

[54] **METHOD AND APPARATUS FOR ANGULAR POSITION AND VELOCITY BASED DETERMINATION OF BODY SWAY FOR THE DIAGNOSIS AND REHABILITATION OF BALANCE AND GAIT DISORDERS**

[76] Inventor: **John H. Allum**, Hebel Str. 109, Basel, Switzerland, CH-4056

[21] Appl. No.: **08/818,319**

[22] Filed: **Mar. 14, 1997**

**Related U.S. Application Data**

- [60] Provisional application No. 60/029,010, Oct. 24, 1996.
- [51] **Int. Cl.<sup>6</sup>** ..... **A61B 5/103**
- [52] **U.S. Cl.** ..... **600/595**
- [58] **Field of Search** ..... 600/587, 595; 73/862.042, 865.4

[56] **References Cited**

**U.S. PATENT DOCUMENTS**

3,090,226	5/1963	Corti et al.	600/595
4,092,633	5/1978	Fletcher et al.	340/213 R
4,738,269	4/1988	Nashner	128/782
4,817,633	4/1989	McStravick et al.	128/782
4,830,024	5/1989	Nashner et al.	128/787
4,848,358	7/1989	Nitzan et al.	128/740
4,938,476	7/1990	Brunelle et al.	600/595
5,052,406	10/1991	Nashner	128/782
5,209,240	5/1993	Jain et al.	128/779
5,281,957	1/1994	Schoolman	345/8
5,303,715	4/1994	Nashner et al.	128/782
5,337,757	8/1994	Jain et al.	128/779
5,361,778	11/1994	Seitz	128/779
5,368,042	11/1994	O'Neil et al.	600/595
5,469,861	11/1995	Piscopo et al.	128/781
5,551,445	9/1996	Nashner	128/782
5,627,327	5/1997	Zanakis	73/862.042
5,749,372	5/1998	Allen et al.	600/595

**FOREIGN PATENT DOCUMENTS**

3416873 A1	11/1985	Germany .
WO 88/04909	7/1988	WIPO .

**OTHER PUBLICATIONS**

- G.H. Begbie, "Some Problems of Postural Sway", in "Myotatic, Kinesthetic and Vestibular Mechanisms", pp. 80-104 (A.V.S. deReuck & Julie Knight, eds., 1967).
- L.M. Nashner, "A Model Describing Vestibular Detection of Body Sway Motion", Acta Otolaryng 72, pp. 429-436, 1971.
- E.V. Gurfinkel, "Physical Foundations of the Stabilography", Agressologie, 14, C, pp. 9-14, 1973.

(List continued on next page.)

*Primary Examiner*—Max Hindenburg  
*Attorney, Agent, or Firm*—Foley & Lardner

[57] **ABSTRACT**

A method and apparatus for the diagnosis and rehabilitation of abnormal postural sway of a subject during standing or the performance of movement tasks is provided. Body sway sensors, such as angular velocity transducers, are attached to the body, such as the upper torso, of the subject. Output signals from the body sway sensors are transformed into detailed body sway angular displacement and velocity information by a system processor. The body sway angular displacement and velocity information may be displayed to an operator for diagnosis of the subject's balance or gait disorders. The angular displacement and velocity information may also be provided as feedback to the subject, to augment the signals normally used by the subject's brain to help stabilize body sway and improve balance. Rehabilitory feedback may be in visual, auditory, and/or tactile form, and/or in the form of electrical stimulation of the vestibular nerve. For visual feedback, a lightweight imaging system mounted on a pair of eyewear may be used to project a body sway angle and angular velocity feedback display into an eye of the subject. An angular position and velocity based body sway diagnosis system in accordance with the present invention may be used to monitor simultaneously the body sway of multiple subjects, and to provide rehabilitory feedback to such subjects, without interfering with or restricting the normal movement activities of the subjects.

**67 Claims, 5 Drawing Sheets**

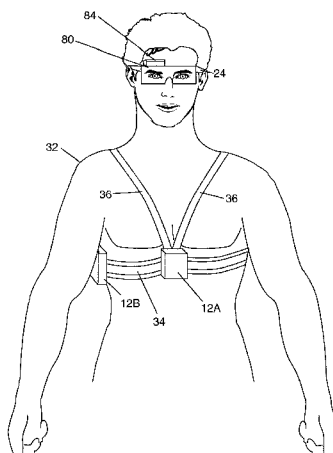

## OTHER PUBLICATIONS

- J. Dichgans, et al., "Postural Sway in Normals and Atactic Patients: Analysis of the Stabilizing and Destabilizing Effects of Vision", *Agressologie* 17, C, pp. 15-24, 1976.
- L.M. Nashner, "Adapting Reflexes Controlling the Human Posture", *Exp. Brain Res.*, vol. 26, pp. 59-72, 1976.
- S.H. Koozekanani, "On the Role of Dynamic Models in Quantitative Posturography", *IEEE Trans. Biomed. Eng.*, vol. BME-27, No. 10, pp. 605-609, Oct. 1980.
- F. Owen Black, et al., "Effects of Visual and Support Surface Orientation References Upon Postural Control in Vestibular Deficient Subjects", *Acta Otolaryngol* 95, pp. 199-210, 1983.
- Mary E. Tinetti, et al., "Fall Risk Index for Elderly Patients Based on Number of Chronic Disabilities", *Am. J. Med.*, vol. 80, pp. 429-434, Mar. 1996.
- F. Owen Black, et al., "Effects of Unilateral Loss of Vestibular Function on the Vestibulo-Ocular Reflex and Postural Control", *Ann. Otol. Rhinol. Laryngol.* 98, pp. 884-889, 1989.
- Emily A. Keshner & John H.J. Allum, "Muscle Activation Patterns Coordinating Postural Stability from Head to Foot", in "Multiple Muscle Systems: Biomechanics and Movement Organization", pp. 481-497, (J.M. Winters & S.L.-Y. Woo, eds., 1990).
- Kamran Barin, "Dynamic Posturography: Analysis of Error in Force Plate Measurement of Postural Sway", *IEEE Eng. in Med. Biol.*, vol. 11, No. 4, pp. 52-56, Dec., 1992.
- D. Perennou, et al., "Optoelectronic assessment of upper body sway in erect posture: validation for 3-D stabilometry", in "Vestibular and neural front", pp. 57-60, (K. Taguchi, et al., eds., 1994).
- Y. Ehara, et al., "Comparison of the performance of 3D camera systems", *Gait & Posture*, vol. 3, pp. 166-169, Sep. 1995.
- Thomas E. Prieto, et al., "Measures of Postural Steadiness: Differences Between Healthy Young and Elderly Adults", *IEEE Trans. Biomed. Eng.*, vol. 43, No. 9, pp. 956-966, Sep. 1996.

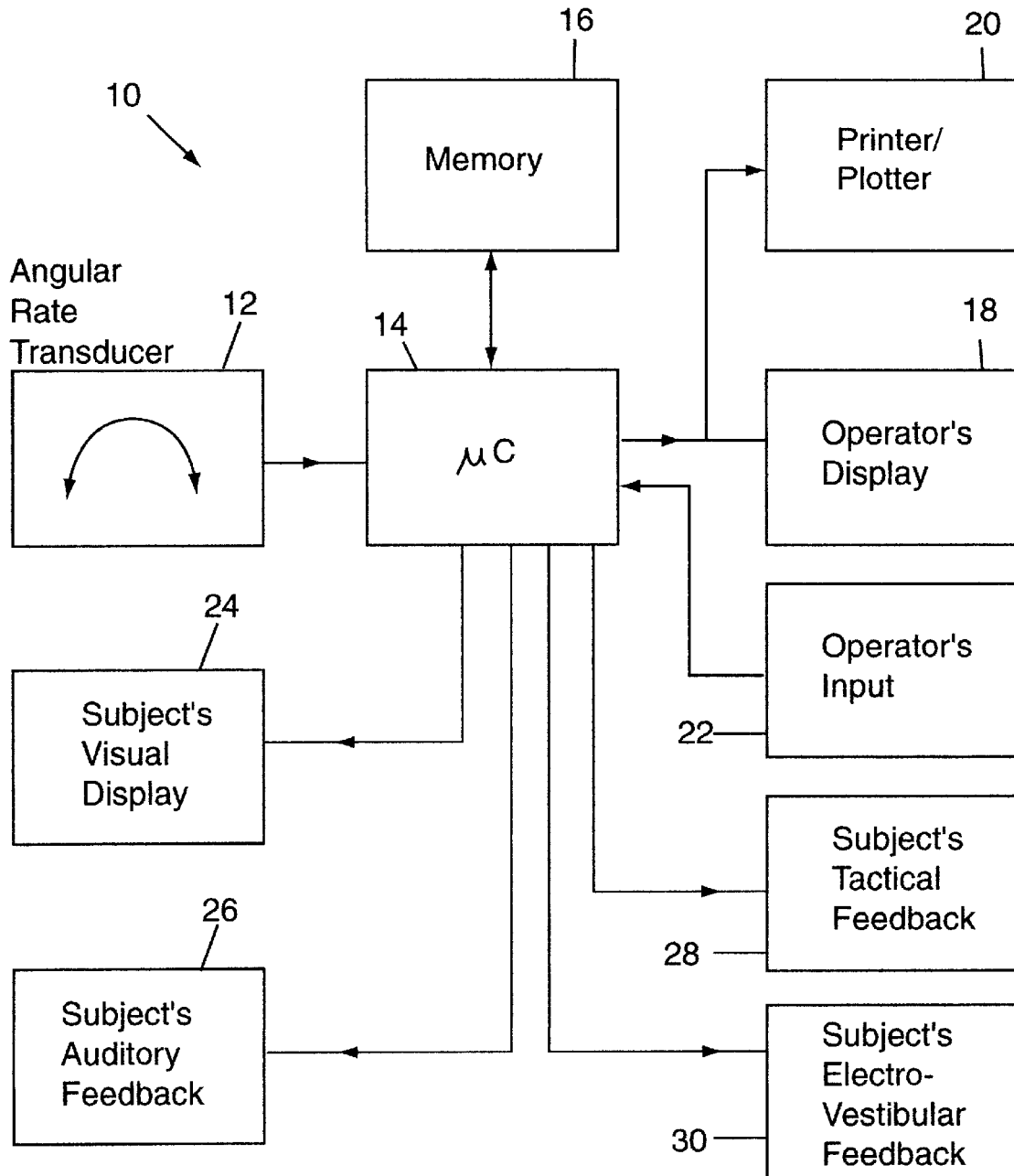

Fig. 1

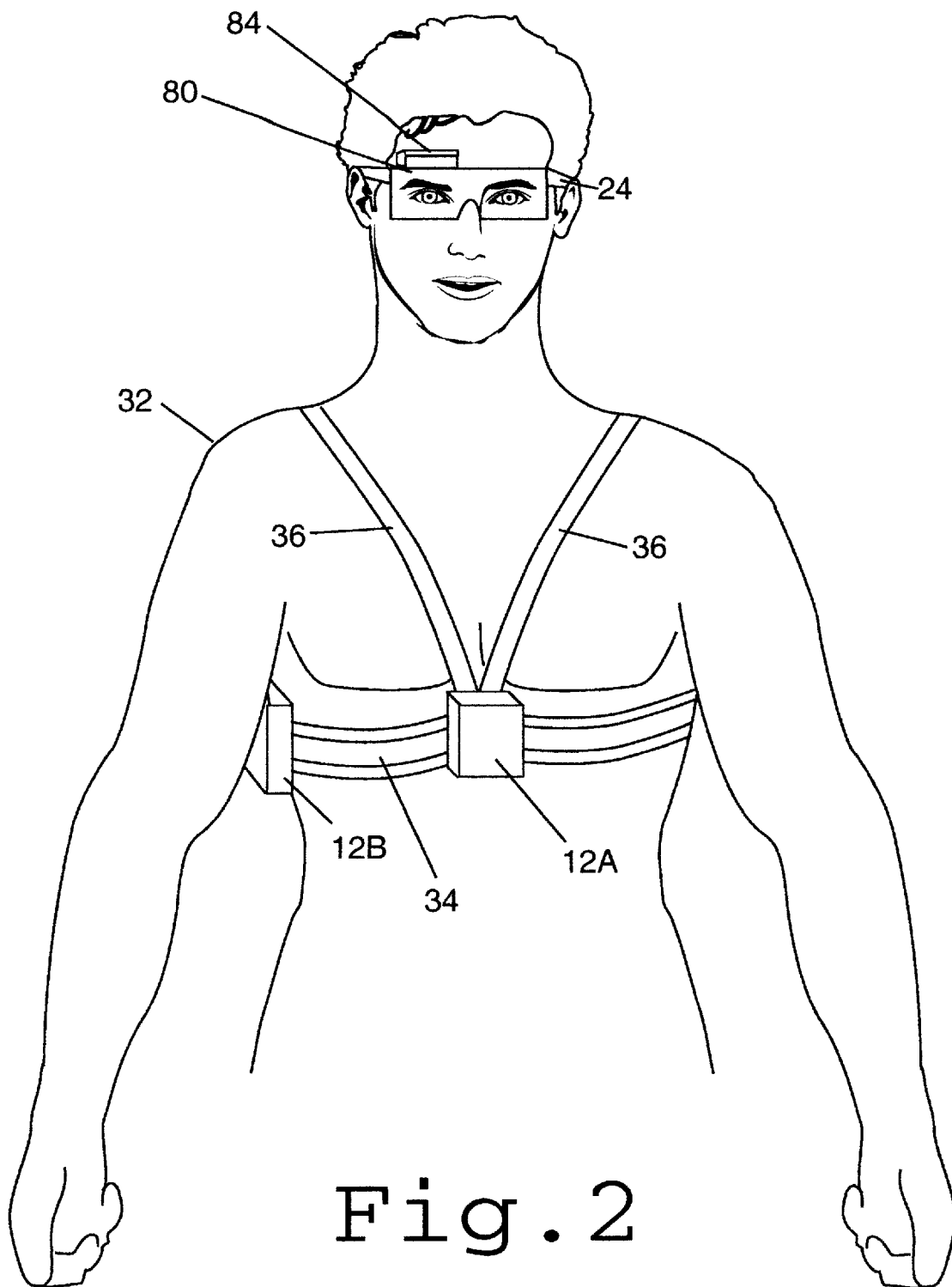

Fig. 2

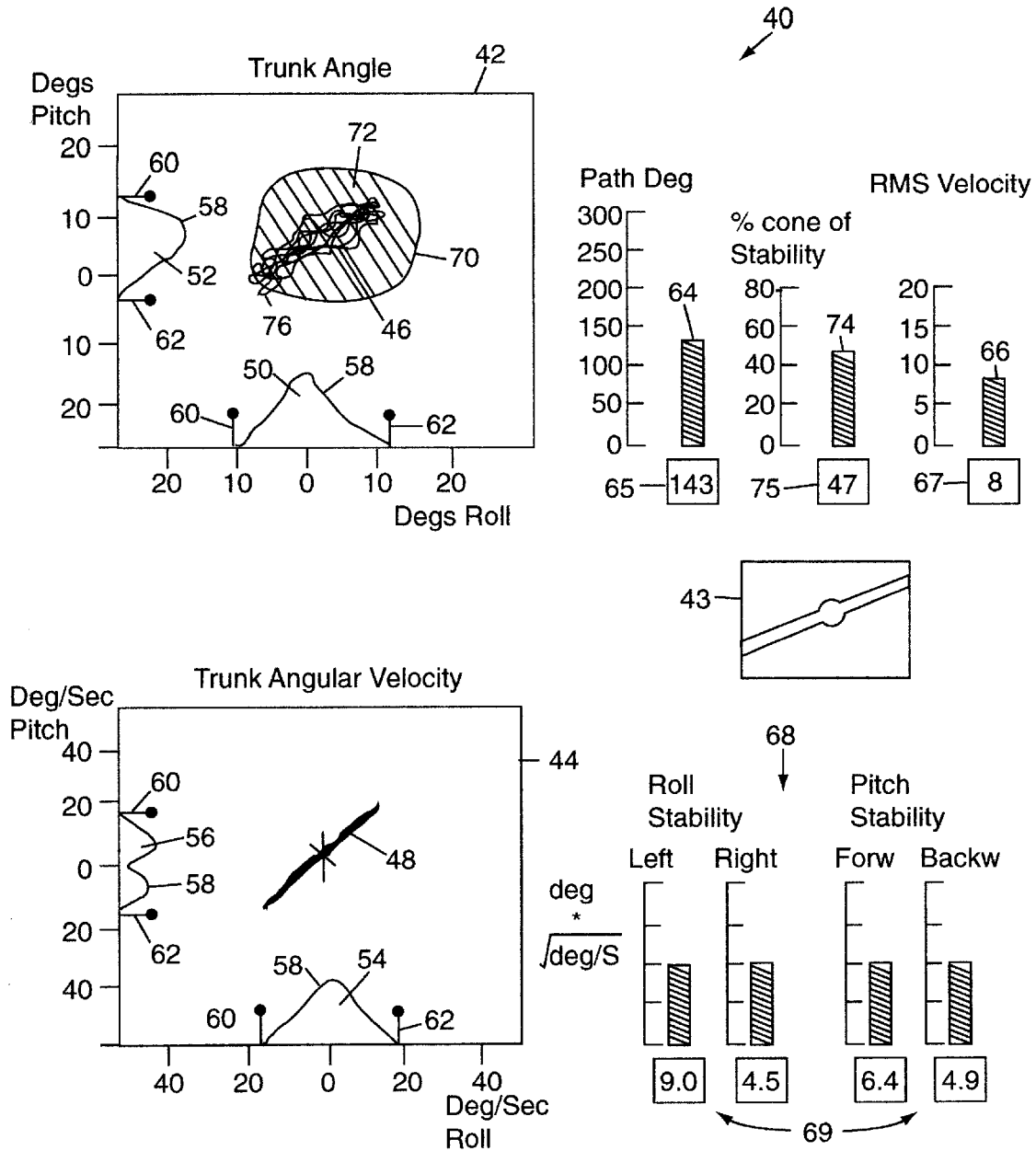

Fig. 3

# Explore Litigation Insights

Docket Alarm provides insights to develop a more informed litigation strategy and the peace of mind of knowing you're on top of things.

## Real-Time Litigation Alerts



Keep your litigation team up-to-date with **real-time alerts** and advanced team management tools built for the enterprise, all while greatly reducing PACER spend.

Our comprehensive service means we can handle Federal, State, and Administrative courts across the country.

## Advanced Docket Research



With over 230 million records, Docket Alarm's cloud-native docket research platform finds what other services can't. Coverage includes Federal, State, plus PTAB, TTAB, ITC and NLRB decisions, all in one place.

Identify arguments that have been successful in the past with full text, pinpoint searching. Link to case law cited within any court document via Fastcase.

## Analytics At Your Fingertips



Learn what happened the last time a particular judge, opposing counsel or company faced cases similar to yours.

Advanced out-of-the-box PTAB and TTAB analytics are always at your fingertips.

## API

Docket Alarm offers a powerful API (application programming interface) to developers that want to integrate case filings into their apps.

## LAW FIRMS

Build custom dashboards for your attorneys and clients with live data direct from the court.

Automate many repetitive legal tasks like conflict checks, document management, and marketing.

## FINANCIAL INSTITUTIONS

Litigation and bankruptcy checks for companies and debtors.

## E-DISCOVERY AND LEGAL VENDORS

Sync your system to PACER to automate legal marketing.