

1 Jason W. Wolff (SBN 215819), wolff@fr.com  
2 Joanna M. Fuller (SBN 266406), jfuller@fr.com  
3 FISH & RICHARDSON P.C.  
4 12390 El Camino Real  
5 San Diego, CA 92130  
6 Phone: (858) 678-5070/ Fax: (858) 678-5099

7 Attorneys for Defendants  
8 HUAWEI DEVICE (DONGGUAN) CO., LTD.,  
9 HUAWEI DEVICE (SHENZHEN) CO., LTD., and  
10 HUAWEI DEVICE USA, INC.

11 *[Additional Counsel listed on signature page.]*

12 UNITED STATES DISTRICT COURT

13 SOUTHERN DISTRICT OF CALIFORNIA

14 BELL NORTHERN RESEARCH,  
15 I.L.C.,

16 Plaintiff,

17 v.

18 COOLPAD TECHNOLOGIES, INC.  
19 AND YULONG COMPUTER  
20 COMMUNICATIONS,

21 Defendants.

Case No. 3:18-cv-01783-CAB-BLM  
*[LEAD CASE]*

**DEFENDANTS' JOINT OPENING  
CLAIM CONSTRUCTION BRIEF**

Date: June 19-20, 2019  
Time: 9:00 a.m.  
Courtroom: 4C  
Judge: Hon. Cathy A. Bencivengo

22 BELL NORTHERN RESEARCH,  
23 LLC,

24 Plaintiff,

25 v.

26 HUAWEI DEVICE (DONGGUAN)  
27 CO., LTD., HUAWEI DEVICE  
28 (SHENZHEN) CO., LTD., and  
HUAWEI DEVICE USA, INC.,

Defendants.

Case No. 3:18-cv-01784-CAB-BLM

**DEFENDANTS' JOINT OPENING  
CLAIM CONSTRUCTION BRIEF**

Date: June 19-20, 2019  
Time: 9:00 a.m.  
Courtroom: 4C  
Judge: Hon. Cathy A. Bencivengo

Case No. 3:18-cv-1783-CAB-BLM [LEAD CASE]

1 BELL NORTHERN RESEARCH,  
2 LLC,  
3 Plaintiff,  
4 v.  
5 KYOCERA CORPORATION and  
6 KYOCERA INTERNATIONAL INC.,  
7 Defendants.  
8

Case No. 3:18-cv-01785-CAB-BLM  
**DEFENDANTS' JOINT OPENING  
CLAIM CONSTRUCTION BRIEF**  
Date: June 19-20, 2019  
Time: 9:00 a.m.  
Courtroom: 4C  
Judge: Hon. Cathy A. Bencivengo

9 BELL NORTHERN RESEARCH,  
10 LLC,  
11 Plaintiff,  
12 v.  
13 ZTE CORPORATION, ZTE (USA)  
14 INC., ZTE (TX) INC.,  
15 Defendants.  
16

Case No. 3:18-cv-01786-CAB-BLM  
**DEFENDANTS' JOINT OPENING  
CLAIM CONSTRUCTION BRIEF**  
Date: June 19-20, 2019  
Time: 9:00 a.m.  
Courtroom: 4C  
Judge: Hon. Cathy A. Bencivengo

17  
18  
19  
20  
21  
22  
23  
24  
25  
26  
27  
28

**TABLE OF CONTENTS**

1

2

3 I. INTRODUCTION ..... 1

4 II. U.S. PATENT NOS. 7,319,889 AND 8,204,554 ..... 1

5     A. Technology Background ..... 1

6     B. “a signal indicative of proximity of an external object” / “a signal  
7         indicative of the existence of a first condition, the first condition being  
8         that an external object is proximate” ..... 2

9 III. U.S. PATENT NO. 7,990,842 ..... 4

10     A. Technology Background ..... 4

11     B. “Inverse Fourier Transformer” ..... 5

12 IV. U.S. PATENT NO. 7,957,450 ..... 9

13     A. Technology Background ..... 9

14     B. Person of Ordinary Skill in the Art (“POSITA”) ..... 11

15     C. “channel estimate matrices” / “matrix based on the plurality of channel  
16         estimates” / “matrix based on said plurality of channel estimates” ..... 12

17     D. “coefficients derived from performing a singular value matrix  
18         decomposition (SVD)” ..... 17

19 V. U.S. PATENT NO. 8,416,862 ..... 19

20     A. Technology Background ..... 19

21     B. Person of Ordinary Skill in the Art (“POSITA”) ..... 20

22     C. “decompose the estimated transmitter beamforming unitary matrix (V)  
23         to produce the transmitter beamforming information” ..... 20

24 VI. U.S. PATENT NO. 6,941,156 ..... 24

25     A. Technology Background ..... 24

26     B. Person of Ordinary Skill in the Art (“POSITA”) ..... 24

27     C. “simultaneous communication paths from said multimode cell phone”  
28         (cl. 1) ..... 25

   D. “a module to establish simultaneous communication paths from said  
       multimode cell phone using both said cell phone functionality and said  
       RF communication functionality” (cl. 1) ..... 34

       1. This Term Is Subject to § 112 ¶ 6 (Means-Plus-Function) ..... 34

       2. Corresponding Function and Structure ..... 37

1 E. “an automatic switch over module, in communication with both said  
2 cell phone functionality and said RF communication functionality,  
3 operable to switch a communication path established on one of said cell  
4 phone functionality and said RF communication functionality, with  
5 another communication path later established on the other of said cell  
6 phone functionality and said RF communication functionality” (cl. 1)41  
7 1. This Term Is Subject to § 112 ¶ 6 (Means-Plus-Function) ..... 41  
8 2. Corresponding Function and Structure ..... 43  
9 VII. U.S. PATENT NO. 7,039,435 ..... 46  
10 A. Technology Background ..... 46  
11 B. “position to a communications tower” ..... 47  
12 VIII. CONCLUSION ..... 51  
13  
14  
15  
16  
17  
18  
19  
20  
21  
22  
23  
24  
25  
26  
27  
28

**TABLE OF AUTHORITIES**

	<b>Page(s)</b>
<b>Cases</b>	
<i>In re Aoyama</i> , 656 F.3d 1293 (Fed. Cir. 2011) .....	38
<i>August Tech. Corp. v. Camtek, Ltd.</i> , 655 F.3d 1278 (Fed. Cir. 2011) .....	16
<i>Chef Am., Inc. v. Lamb Weston, Inc.</i> , 358 F.3d 1371 (Fed. Cir. 2004) .....	50
<i>Embrex, Inc. v. Serv. Eng’g Corp.</i> , 216 F.3d 1343 (Fed. Cir. 2000) .....	47
<i>Fenner Invs., Ltd. v. Cellco P’ship</i> , 778 F.3d 1320 (Fed. Cir. 2015) .....	31
<i>GE Lighting Solutions, LLC v. AgiLight, Inc.</i> , 750 F.3d 1304 (Fed. Cir. 2014) .....	1, 48
<i>Helmsderfer v. Bobrick Washroom Equip., Inc.</i> , 527 F.3d 1379 (Fed. Cir. 2008) .....	15
<i>Markman v. Westview Instruments, Inc.</i> , 52 F.3d 967 (Fed. Cir. 1995) (en banc) .....	7
<i>Phillips v. AWH Corp.</i> , 415 F.3d 1303 (Fed. Cir. 2005) .....	1, 18, 26, 47
<i>Standard Oil Co. v. Am. Cyanamid Co.</i> , 774 F.2d 448 (Fed. Cir. 1985) .....	31
<i>Tech. Props. Ltd. LLC v. Huawei Techs. Co., Ltd.</i> , 849 F.3d 1349 (Fed. Cir. 2017) .....	31
<i>Terlep v. Brinkmann Corp.</i> , 418 F.3d 1379 (Fed. Cir. 2005) .....	14
<i>Thorner v. Sony Comput. Entm’t Am. LLC</i> , 669 F.3d 1362 (Fed. Cir. 2012) .....	8, 47, 48

1 *Tomita Techs. USA, LLC v. Nintendo Co.*,  
2 681 F. App'x 967 (Fed. Cir. 2017) ..... 41, 46  
3 *Williamson v. Citrix Online, LLC*,  
4 792 F.3d 1339 (Fed. Cir. 2015) .....*passim*  
5 *WMS Gaming Inc. v. Int'l Game Tech.*,  
6 184 F.3d 1339 (Fed. Cir. 1999) ..... 38  
7  
8  
9  
10  
11  
12  
13  
14  
15  
16  
17  
18  
19  
20  
21  
22  
23  
24  
25  
26  
27  
28

1 **I. INTRODUCTION**

2 Plaintiff BNR sued the Defendants (Coolpad, Huawei, Kyocera, and ZTE),  
3 alleging certain cell phones and tablets infringe its patents. The patents purport to  
4 relate to wireless communications, as well as power management techniques (*e.g.*,  
5 the use of proximity sensors). BNR has asserted eight patents against Huawei and  
6 ZTE, and a subset of these against Kyocera (six patents) and Coolpad (four patents).

7 Defendants' proposed constructions, as reflected below, properly begin with  
8 the plain meaning of terms informed by the intrinsic evidence. *Phillips v. AWH*  
9 *Corp.*, 415 F.3d 1303, 1314-15 (Fed. Cir. 2005). Defendants propose a usage  
10 consistent with and supported by the specifications, *id.* at 1316, absent a clear  
11 disclaimer, *GE Lighting Solutions, LLC v. AgiLight, Inc.*, 750 F.3d 1304, 1309 (Fed.  
12 Cir. 2014). BNR, however, proposes constructions to impermissibly broaden or  
13 rewrite its claims. For these reasons, Defendants' proposals should be adopted.

14 **II. U.S. PATENT NOS. 7,319,889 AND 8,204,554**

15 **A. Technology Background**

16 The '889 and '554 patents ("the Goris patents") share a common  
17 specification.<sup>1</sup> They pertain to a mobile station (*e.g.*, a cordless or cellular  
18 telephone) that includes "a proximity sensor . . . adapted to cause [the] power  
19 consumption of the display to be reduced when the display is within a  
20 predetermined range of an external object." '889 (Doc. No. 1-3)<sup>2</sup> at Abstract, 1:21-  
21 26, 1:42-46; *see also id.* at 3:13-15, 3:20-32. Their common specification teaches  
22 that, during a telephone call, the display "is not needed" when "the display [is] near  
23 to an object, in particular to the ear" of a user. *See id.* at 1:47-51, 1:55-58, 1:62-2:1,  
24 2:18-24, 3:12-39, 3:55-58. The patents disclose activating a proximity sensor during

---

26 <sup>1</sup> Because the Goris patent specifications are the same, for simplicity, citations are  
27 provided only for the earlier-issued '889 patent.

28 <sup>2</sup> Doc. Nos. referenced herein refer to BNR v. Huawei, 3:18-cv-1784 unless  
otherwise noted.

1 incoming and outgoing calls. *Id.* at Abstract, 3:7-15, 3:33-35, 3:48-55, Figs. 3, 4.  
 2 The proximity sensor detects whether an external object is “within a predetermined  
 3 range.” *See id.* at Abstract, 1:43-46, 3:13-15, 3:20-25, 3:33-39, 3:55-58. When the  
 4 proximity sensor detects an external object within the predetermined range, “the  
 5 power consumption of the display 150 is reduced, most preferably by switching the  
 6 display 150 completely off.” *See id.* at Abstract, 1:43-46, 1:55-58, 1:62-64, 2:18-24,  
 7 3:20-25, 3:35-39, 3:55-58, Fig. 3. When the external object moves out of range  
 8 (*e.g.*, when the user moves the phone away from his or her ear), the proximity  
 9 sensor detects that event as well, and the “the display 150 is switched back on.” *Id.*  
 10 at 2:6-9, 3:26-32.

11 **B. “a signal indicative of proximity of an external object” / “a signal**  
 12 **indicative of the existence of a first condition, the first condition being**  
 13 **that an external object is proximate”<sup>3</sup>**

Defendants’ Construction	BNR’s Construction
“a signal that an external object is or is not within a predetermined range”	“a signal that an external object is within a predetermined range”

16 Claim 1 of the ’889 patent recites “a proximity sensor adapted to generate a  
 17 signal indicative of proximity of an external object.” Claims 1 and 14 of the ’554  
 18 patent recite “a proximity sensor adapted to generate a signal indicative of the  
 19 existence of a first condition, the first condition being than an external object is  
 20 proximate.” Through their continuing negotiations, the parties have narrowed this  
 21 dispute to a single issue: must the signal generated by the proximity sensor be  
 22 capable of indicating only that an external object *is* within a predetermined range (as  
 23 BNR contends) or must that signal also be capable of indicating that an external  
 24

---

26 <sup>3</sup> The parties have agreed to a construction of “the signal is that an external object is  
 27 within a predetermined range” for the phrase “the signal indicates the proximity of  
 28 the external object,” and they will file a Supplemental Joint Hearing Statement  
 reflecting this agreement.



1 object is no longer (or *is not*) within the predetermined range as well (as Defendants  
2 contend).

3       The claims of the Goris patents demonstrate that Defendants’ construction is  
4 correct. For example, claim 1 of the ’889 patent requires the proximity sensor to  
5 “detect[] whether an external object is proximate” to the display. *Id.* at 4:21-22.  
6 The use of “whether” indicates alternatives, *i.e.*, the sensor either determines that an  
7 external object is proximate or it determines that the external object is not  
8 proximate. As further recited in claim 1, the proximity sensor is “adapted to  
9 generate a signal indicative of proximity of an external object” based on its  
10 determination of “whether an external object is proximate.” *See id.* at 4:5-6, 4:21-  
11 22. The proximity sensor’s signal must be capable of indicating the two  
12 alternatives, thus, the claimed signal is “a signal that an external object is or is not  
13 within a predetermined range.”

14       Sometimes, that signal will state “yes, the external object is proximate.” *See*  
15 *supra* n.3. But other times, the claimed signal must be able to state “no, the external  
16 object is not proximate.” For example, claims 2 and 9 of the ’554 patent explicitly  
17 confirm that the claimed signal must have the “is not proximate” state. Claim 2  
18 recites “increasing power to the display *if the signal from the activated proximity*  
19 *sensor indicates that the first condition no longer exists.*” ’554 (Doc No. 1-4) at  
20 4:24-26 (emphasis added). The “first condition no longer exists” if an external  
21 object is not proximate. *See id.* at 4:4-6. Claim 9 similarly claims “increasing  
22 power consumption of the display *if the signal from the activated proximity sensor*  
23 *indicates that the proximity condition no longer exists.*” *Id.* at 4:62-64 (emphasis  
24 added). In other words, both of these claims expressly require the signal generated  
25 by the proximity sensor also be capable of indicating that the external object is not  
26 proximate (and then more power will go to the display of the mobile station). By  
27  
28

1 excluding the “or is not” state of the claimed signal, BNR’s proposed construction  
2 contradicts this explicit claim language.

3 The Goris patents’ common specification further supports Defendants’  
4 construction. The specification discloses two actions depending on what the  
5 proximity sensor detects. First, “[i]f the proximity sensor 140 detects an external  
6 object (such as the user’s ear) within the monitored range, the power consumption of  
7 the display 150 is reduced.” ’889 at Abstract, 1:41-46, 1:55-58, 1:62-64, 2:18-24,  
8 3:20-25, 3:35-39, 3:55-58, Fig. 3. Second, in response to the external object  
9 “mov[ing] out of range” of the proximity sensor, “the display 150 is switched back  
10 on.” *Id.* at 3:26-32; *see also id.* at 2:6-9. Figures 3 and 4 are flow diagrams that  
11 show (at 304 and 404) the determination made by the proximity sensor. *Id.* at 2:49-  
12 52, Figs. 3, 4. The proximity sensor determines whether an external object is  
13 proximate. The result is either “yes” or “no.” *Id.* Only Defendants’ proposed  
14 construction is consistent with the claims and specification.

### 15 **III. U.S. PATENT NO. 7,990,842**

#### 16 **A. Technology Background**

17 The ’842 patent relates to how data is encoded for transmission from a  
18 wireless device. An encoding technique helps put the data in a format that can be  
19 transmitted and then, later, decoded by the receiver essentially using an inverse of  
20 the encoding technique. As background, the ’842 patent states that “both the  
21 802.11a and 802.11g standards use an orthogonal frequency division multiplexing  
22 (OFDM) encoding scheme.” ’842 (Doc No. 1-5) at 2:8-10.<sup>4</sup> “OFDM works by  
23

---

24 <sup>4</sup> The “802.11” standards are a set of communication protocols promulgated by the  
25 Institute of Electronics and Electrical Engineers (“IEEE”). “802” refers to IEEE  
26 802 local area network (“LAN”) protocol standards, while “802.11” are a subset of  
27 802 standards that specify two layers of the network protocol “stack”—the media  
28 access layer (“MAC”) and the physical access layer (“PHY”)—for implementing  
wireless local area networks (“WLAN”) WiFi communications in certain

1 spreading a single data stream over a band of sub-carriers, each of which is  
 2 transmitted in parallel.” *Id.* at 2:12-14. “In 802.11a/802.11g, each data packet starts  
 3 with a preamble which includes a short training sequence followed by a long  
 4 training sequence. The short and long training sequences are used for  
 5 synchronization between the sender and the receiver.” *Id.* at 2:30-34. These  
 6 training sequences use a form of modulation known as Binary Phase Shift Keying or  
 7 BPSK, in which a +1 maps to transmitting the sub-carrier with a 0-degree phase  
 8 shift and a -1 maps to transmitting the subcarrier with a 180-degree phase shift. The  
 9 ’842 patent purports to address a “need to create a long training sequence of  
 10 minimum peak-to-average ratio [(‘PAPR’)] that uses more sub-carriers without  
 11 interfering with adjacent channels.” *Id.* at 2:36-38. According to the patent, its  
 12 approach “decreases power back-off” and “should be usable by legacy devices in  
 13 order to estimate channel impulse response and to estimate carrier frequency offset  
 14 between a transmitter and a receiver.” *Id.* at 2:41-43, 4:4-6.

15 **B. “Inverse Fourier Transformer”**

Defendants’ Construction	BNR’s Construction
“a circuit and/or software that performs a defined mathematical function that transforms a series of values from the frequency domain into the time domain”	“Plain and ordinary meaning, alternatively to the extent the Court determines that a specific construction is warranted: circuit and/or software that at least performs an inverse Fourier transform.”

21 The parties agree that an Inverse Fourier Transformer can be a circuit and/or  
 22 software. Otherwise, Defendants seek to construe the Inverse Fourier Transformer  
 23

24  
 25 \_\_\_\_\_  
 26 communication frequency bands (e.g., 2.4 GHz, 5 GHz, and 60 GHz). Often,  
 27 products purporting to comply with aspects of the 802.11 standard are branded as  
 28 “Wi-Fi” products. Amendments and improvements to the base standards get  
 additional letter designations, such as 802.11a or 802.11b. *See, e.g.,*  
<http://www.ieee802.org/11>.

1 consistent with the '842 patent's claims and specification, while BNR seeks a non-  
 2 construction.

3 Only Defendants' proposed construction accurately captures what the Inverse  
 4 Fourier Transformer does with the "extended long training sequence," as recited in  
 5 the claims. Independent claim 1 recites "a signal generator that generates an  
 6 extended long training sequence." '842 at cl. 1. "[T]he Inverse Fourier Transformer  
 7 processes the extended long training sequence from the signal generator and  
 8 provides an optimal extended long training sequence." *Id.* Thus, the Inverse  
 9 Fourier Transformer converts the BPSK modulated sub-carriers (a sequence defined  
 10 in the frequency domain) into an "optimal extended long training sequence" (a  
 11 sequence defined in the time domain).

12 The specification describes the operation of an "Inverse Fourier Transform"  
 13 in accordance with Defendants' proposal: "[s]ignal generating circuit 205 generates  
 14 the expanded long training sequence and if 56 active *sub-carriers* are being used,  
 15 signal generating circuit generates . . . and stores the expanded long training  
 16 sequence in *sub-carriers* -28 to +28. . . . The inventive long training sequence is  
 17 inputted into an Inverse Fourier Transform 206." *Id.* at 4:41-52 (emphasis added).  
 18 Figure 2, reproduced below, has the Inverse Fourier Transform 206 outlined in red.



Figure 2

1 The specification further confirms that the output of block 206, “the Inverse  
 2 Fourier Transform,” which is an input to block 208, is a time domain signal:  
 3 “[s]erial to parallel module 208 converts the serial *time domain signals* into parallel  
 4 *time domain signals* that are subsequently filtered and converted to analog signals  
 5 via the D/A [(digital-to-analog converter)].” *Id.* at 4:61-64 (emphasis added). The  
 6 specification teaches that a frequency domain signal is the input to the Inverse  
 7 Fourier Transform, and the resultant output signal is a time domain signal, precisely  
 8 as described in Defendants’ construction. The creation of parallel time domain  
 9 streams is necessary to transmit the signal on multiple antennas via independent  
 10 digital to analog converters, as described above.

11 Both of BNR’s proposals are flawed. First, BNR’s proposal that Inverse  
 12 Fourier Transformer be given its plain and ordinary meaning does not help the jury,  
 13 nor the Court, understand what this highly technical term would mean to person of  
 14 ordinary skill in the art. *Markman v. Westview Instruments, Inc.*, 52 F.3d 967, 976  
 15 (Fed. Cir. 1995) (en banc). Second, BNR’s alternate proposal is effectively a non-  
 16 construction wherein BNR simply parrots back the language of the claim and does  
 17 not explain the highly technical term “Inverse Fourier Transformer.”

18 Defendants do not dispute that a Fourier transform can operate in more than  
 19 one dimension. But BNR’s assertions that “Defendants’ proposed construction  
 20 erroneously restricts the inverse Fourier Transform to time and frequency domains”  
 21 and “there is no specific direction for the transform required by the claims” are  
 22 incorrect and contradict the intrinsic evidence. *See, e.g.*, Ex. A (Madisetti Op.  
 23 Decl.) at ¶ 192.<sup>5</sup> First, “[t]he words of a claim are generally given their ordinary and  
 24

---

25 <sup>5</sup> Pursuant to the Court’s Consolidation Order dated February 2, 2019 and direction  
 26 to the parties during the April 26, 2019 Claim Construction Status Hearing,  
 27 Defendants are filing consolidated Claim Construction and Indefiniteness Briefs.  
 28 Doc. No. 60 at 3; Ex. B (Apr. 26, 2019 Status Hr’g Tr.) at 9:9-10:9. Given BNR’s  
 use of Dr. Madisetti’s opinions in a manner directly adverse to ZTE, ZTE must

1 customary meanings as understood by a person of ordinary skill in the art when read  
2 in the context of the specification and prosecution history.” *Thorner v. Sony*  
3 *Comput. Entm’t Am. LLC*, 669 F.3d 1362, 1365 (Fed. Cir. 2012). Nowhere does the  
4 specification mention an Inverse Fourier Transformer operating on anything other  
5 than a one-dimensional signal. Nowhere does the specification disclose the Inverse  
6 Fourier Transformer operating on a space or spatial signal, or any other variable  
7 other than time or frequency.

8         Second, the Inverse Fourier Transformer has a specified direction. The  
9 specification teaches that the “FFT [(fast Fourier transform)] module 36 *converts*  
10 the serial *time domain signals into frequency domain signals*.” ’842 at 5:8-9  
11 (emphasis added). The specification also teaches that the “Inverse Fourier  
12 Transform 206 may be an *inverse* Fast Fourier Transform (IFFT).” *Id.* at 4:53-55  
13 (emphasis added). If there were no specified direction, there would be no need for  
14 an inverse transform.

15         Defendants’ proposal clarifies that in the context of the claims and the  
16 specification, a wireless communications system using Orthogonal *Frequency*  
17 *Domain* Multiplexing (OFDM), that the Inverse Fourier Transformer maps the  
18 frequency domain sub-carriers into a time domain representation as defined by the  
19 mathematical function of an inverse Fourier Transform. “OFDM is a frequency  
20 division multiplexing modulation technique for transmitting large amounts of digital  
21 data over a radio wave. OFDM works by spreading a single data stream over a band  
22 of sub-carriers, each of which is transmitted in parallel.” *Id.* at 2:10-14. The very  
23 nature of OFDM, as described by the specification, is to start with a frequency  
24 domain signal and distribute the data to be transmitted over a band of sub-carriers in  
25 the frequency domain, each of which is transmitted in parallel via the Inverse

26 \_\_\_\_\_  
27 address BNR’s positions in this consolidated brief. However, ZTE maintains and  
28 does not waive its objections to BNR’s use of Dr. Madisetti for the reasons cited in  
its Motion to Strike dated May 8, 2019. *BNR v. ZTE*, 3:18-cv-1786, Doc. No. 84.

1 Fourier Transformer converting the frequency domain signal to its corresponding  
2 time domain representation.

3 For these reasons, Defendants’ construction should be adopted.

4 **IV. U.S. PATENT NO. 7,957,450**

5 **A. Technology Background**

6 The ’450 patent relates to antenna “beamforming” in wireless communication  
7 systems. Beamforming is like shining a beam of light at an intended area. In  
8 contrast to antennas which transmit a radio frequency (“RF”) signal in all directions,  
9 beamforming is a technique using multiple antennas to focus an RF signal (a  
10 “beam”) toward the intended receiver. Ex. C (Min Op. Decl.) at ¶ 41. As a result, a  
11 stronger signal is available to the intended receiver. ’450 (Doc. No. 33-6) at 1:37-  
12 41; 3:8-14.

13 In general terms, beamforming requires coordinating the arrival of the  
14 transmitted signals at the receiving device. To implement this technique, the  
15 transmitting device mathematically modifies the signals to be transmitted by each  
16 antenna using a beamforming “matrix.”<sup>6</sup> Importantly, to construct an appropriate  
17 beamforming matrix, the transmitting device must obtain information about the  
18 characteristics of the RF channel to the receiving device. The claims of the ’450  
19 patent are directed to “feedback information” sent by the receiving device back to  
20 the transmitting device to help the transmitting device construct an appropriate  
21 beamforming matrix.

22 This concept is illustrated in Figure 2 below, which depicts a “transmitting  
23 mobile terminal 202,” a “receiving mobile terminal 222,” and “RF channels 242.”  
24 *Id.* at 11:32-36. To focus a beam, the transmitting mobile terminal modifies the  
25 source signals 206, 208, 210 based on beamforming matrix V 204 before they are  
26

---

27 <sup>6</sup> A “matrix” is a two-dimensional array of values. An example of a 2×2 matrix,  
28 which is a matrix that includes two rows and two columns, is:  $\begin{bmatrix} 1 & 2 \\ 3 & 4 \end{bmatrix}$ .

1 transmitted from antennas 212, 214, 216. *Id.* at 11:41-54. The characteristics of RF  
 2 channels 242 through which the signals are transmitted may be represented  
 3 mathematically by a matrix,  $H$ , which is another two-dimensional array of values.  
 4 *Id.* at 11:61-65. The receiving mobile terminal includes antennas 232, 234, and 236  
 5 to receive the signals transmitted through the RF channels 242. *Id.* at 11:55-59.

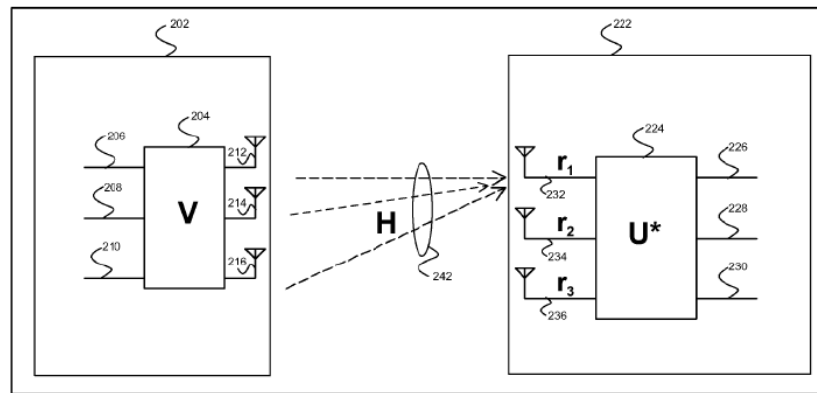

13 '450 at Fig. 2.

14 To construct an appropriate beamforming matrix  $V$ , the transmitting mobile  
 15 terminal must take into account the characteristics of the RF channel, which is  
 16 represented by the matrix  $H$ .<sup>7</sup> Due to signal fading effects on the RF channel, the  
 17

18 <sup>7</sup> The patentee chose the notation " $H$ " to identify a mathematical representation of  
 19 an RF channel. '450 at 3:53-66. However, the patentee also uses " $H$ " in  
 20 conjunction with various additional notations to provide additional specificity, but  
 21 each refers to an RF channel. " $H_{est}$ " is used to identify an RF "channel estimate  
 22 matrix which is computed by a receiving mobile terminal." *Id.* at 8:52-56. " $H(t)$ "  
 23 is used to identify  $H$  "as a function of time," where " $t$ " refers to the RF channel  
 24 characteristics at a specific instant in time. *Id.* at 4:5-9. " $H_{up}$ " is used to identify a  
 25 "reverse channel estimate matrix" that is "computed by a receiving mobile  
 26 terminal," where the term "reverse" refers to an "uplink" RF channel (i.e., channel  
 27 for signals transmitted from the receiving mobile terminal to the transmitting mobile  
 28 terminal). *Id.* at 4:66-5:2. " $H_{down}$ " is used to identify a "forward channel estimate  
 matrix" that is "computed by a transmitting mobile terminal," where the term  
 "forward" refers to a "downlink" RF channel (i.e., channel for signals transmitted  
 from the transmitted mobile terminal to the receiving mobile terminal). *Id.* at 5:2-  
 5:7.



1 values in the matrix  $H$  may rapidly change. *Id.* at 3:49-53; 8:36-39. To assist in the  
 2 beamforming process, the receiving mobile terminal may periodically send feedback  
 3 information to the transmitting mobile terminal. *Id.* at 1:30-34. To do so, the  
 4 receiving terminal computes a channel estimate matrix  $H_{est}$  based on the signals  
 5 received. Then, the receiving mobile terminal performs a singular value  
 6 decomposition (SVD) on the channel estimate matrix. *Id.* at 7:67-8:5. SVD is a  
 7 mathematical operation that is used to decompose (*e.g.*, factor) a matrix, such as the  
 8 channel estimate matrix, into the product of three other matrices, namely matrices  
 9  $U$ ,  $S$ , and  $V^H$ .<sup>8</sup> Ex. D (Min Reb. Decl.) at ¶ 57. The receiving mobile terminal may  
 10 then transmit back to the transmitting mobile terminal coefficients of the SVD-  
 11 derived matrices ( $U$ ,  $S$ , and  $V^H$ ) as “feedback information.” ’450 at 7:67-8:5; 8:28-  
 12 33.

13 **B. Person of Ordinary Skill in the Art (“POSITA”)**

14 The parties’ experts generally agree on the level of ordinary skill for the ’450  
 15 Patent and their opinions are not affected by any differences. Ex. D (Min Reb.  
 16 Decl.) at ¶ 51; Ex. E (Madisetti Reb. Decl.) at ¶ 71. Dr. Min states that a POSITA  
 17 would have had a Bachelor’s degree in Electrical Engineering, Computer  
 18 Engineering, Computer Science, or a related field, and between 2 to 4 years of  
 19 experience in the field of wireless communication, or a person with equivalent  
 20 education, work, or experience in this field. Ex. C (Min Op. Decl.) at ¶¶ 136-38;  
 21 Ex. A (Madisetti Op. Decl.) at ¶ 129.

22  
 23  
 24

---

25 <sup>8</sup> A real number, such as the number 24, may be factored into the product of other  
 26 real numbers 2, 3, and 4, as shown by the equation:  $24=2\times 3\times 4$ . Ex. D (Min Reb.  
 27 Decl.) at ¶ 57 n.2. Matrices similarly can be factored. Using SVD, a matrix  $H_{est}$   
 28 may be decomposed (factored) into the product of three matrices  $U$ ,  $S$ , and  $V^H$ , as  
 shown by “equation[2]”:  $H_{est} = U \times S \times V^H$ , or just  $H_{est}=USV^H$ . ’450 at 8:52-65.

1           **C. “channel estimate matrices” / “matrix based on the plurality of**  
 2           **channel estimates” / “matrix based on said plurality of channel**  
 3           **estimates”**

Defendants’ Construction	BNR’s Construction
“matrix $H_{est}$ for tones of different frequencies, where $H_{est}$ contains estimates of the true values of $H(t)$ ”	Plain and ordinary meaning.  In the alternative, to the extent the Court determines that a specific construction is warranted, BNR proposes: “one or more matrices that is based on an SVD decomposition of the estimates of the values of $H(t)$ ”

10           The parties dispute similarly-recited terms in each of the four independent  
 11 claims. Claims 1 and 11 recite “computing a plurality of *channel estimate matrices*  
 12 based on signals received.” Claims 21 and 22 recite “computing a plurality of  
 13 channel estimates based on signal received [and] . . . deriving a *matrix based on*  
 14 *[the / said] plurality of channel estimates.*”

15           In particular, the claims recite that the receiving mobile terminal computes,  
 16 *based on signals received*, an estimate of a matrix ( $H_{est}$ ) that mathematically  
 17 represents the RF channel that lies between a transmitting device and the receiving  
 18 mobile terminal. ’450 at 19:14-16 (cl. 1); Ex. C (Min Op. Decl.) at ¶ 152. The key  
 19 dispute is whether the channel estimate matrices are “based on an SVD  
 20 decomposition.” They are not because SVD is an operation performed on a channel  
 21 estimate matrix *after* the receiving mobile terminal has already computed the  
 22 channel estimate matrix, as explained below.

23           The specification further supports Defendants’ proposed construction. In  
 24 “equation [1]” of the specification, a matrix “H” is used to represent the channel:

25           A communications medium, such as a radio frequency (*RF*)  
 26           *channel* between a transmitting mobile terminal and a  
 27           receiving mobile terminal, *may be represented by a*  
 28           *transfer system function, H*. The relationship between a  
 time varying transmitted signal,  $x(t)$ , a time varying

1 received signal,  $y(t)$ , and the systems function may be  
2 represented as shown in equation [1]:

3  $y(t)=H\times x(t)+n(t)$ , where equation[1]

4  $n(t)$  represents noise which may be introduced as the signal  
5 travels through the communications medium and the  
6 receiver itself. In MIMO systems, *the elements in*  
7 *equation[1] may be represented as vectors and matrices.*

8 '450 at 3:53-66; Ex. C (Min Op. Decl.) at ¶ 143. In other words, according to  
9 equation [1], “when the transmitter transmits signal  $x(t)$ , the channel modifies it with  
10  $H$ , which characterizes the channel, and the receiver receives signal  $Hx(t)$  together  
11 with noise  $n(t)$ , which corrupts the received signal.” Ex. C (Min Op. Decl.) at ¶ 152.  
12 Equation [1] is taught in introductory communication theory courses at the  
13 undergraduate level and is well known among persons of ordinary skill. *Id.*

14 In wireless communications, the transmitted signal is subject to fading as the  
15 RF channel characteristics (*i.e.*, “ $H$ ”) vary over time. '450 at 1:63-65. Thus, “ $H$   
16 may be represented as a function of time,  $H(t)$ ,” where “ $t$ ” refers to the RF channel  
17 characteristics at a specific instant in time. '450 at 4:5-9; Ex. C (Min Op. Decl.) at  
18 ¶ 144; Ex. D (Min Reb. Decl.) at ¶ 55. In addition, in systems designed to use  
19 multiple frequencies to transmit signals,<sup>9</sup> the characteristics of the channel estimate  
20 matrix  $H(t)$  may differ for each tone (*i.e.*, each different frequency) transmitted via  
21 the RF channel:

22 The computations which are performed at the receiving  
23 mobile terminal may *constitute an estimate of the “true”*  
24 *values of  $H(t)$  and may be known as “channel estimates”.*  
25 For a frequency selective channel *there may be a set of  $H(t)$*   
26 *coefficients for each tone* that is transmitted via the RF  
27 channel. To the extent that  *$H(t)$ , which may be referred to*

28 <sup>9</sup> The '450 patent refers to orthogonal frequency division multiplexing (OFDM)  
based wireless communication systems, which utilize more than one frequency to  
transmit data to a receiving mobile terminal. '450 at 3:14-21.

1            *as the “channel estimate matrix”*, changes with time and  
2            to the extent that the transmitting mobile terminal fails to  
3            adapt to those changes, information loss between the  
4            transmitting mobile terminal and the receiving mobile  
             terminal may result.

5            ’450 at 4:14-24; Ex. C (Min Op. Decl.) at ¶ 144.<sup>10</sup> Indeed, Plaintiff’s expert  
6            acknowledges that “channel estimate matrices” are the “H” matrices computed  
7            “from signals received” by the receiving mobile terminal:

8                        “Turning to the claim language, the method requires  
9                        computing one or more *channel estimate matrices, H(t)*  
10                        *from signals received* by a wireless communication device  
                      from a base station.”

11            Ex. A (Madisetti Op. Decl.) at ¶ 139.

12            Consistent with the notion that a matrix H “constitute[s] an estimate of the  
13            ‘true’ values of H(t),” the patentee chose the notation “ $H_{est}$ ” to represent a matrix  
14            “computed by a receiving mobile terminal” that is “an estimate” of the channel.  
15            ’450 at 4:14-17, 8:52-56; Ex. C (Min Op. Decl.) at ¶¶ 146, 149. Furthermore, the  
16            patentee explained that “a plurality of *channel estimate matrices, H<sub>est</sub>*, may be  
17            computed to account for each tone which may be transmitted via the RF channel.”  
18            ’450 at 9:33-37; Ex. C (Min Op. Decl.) at ¶ 147. Thus, Defendants’ construction  
19            properly construes the disputed terms in view of the entire patent to mean “matrix  
20             $H_{est}$  for tones of different frequencies, where  $H_{est}$  contains estimates of the true  
21            values of H(t).”

22            BNR’s proposed construction deviates from the claim language to construe  
23            the disputed channel estimate matrices as “based on an SVD decomposition.” Ex. D  
24            (Min Reb. Decl.) at ¶ 54; *Terlep v. Brinkmann Corp.*, 418 F.3d 1379, 1382 (Fed.  
25

---

26  
27            <sup>10</sup> The ’862 patent similarly identifies an estimated “channel response” as a matrix  
28            “H.” ’862 at 3:14-33, 13:36-53; Ex. C (Min Op. Decl.) at ¶ 148 n.4. The named  
             inventors of the ’862 patent are also named inventors of the ’450 patent.

1 Cir. 2005) (“The construction of claims is simply a way of elaborating the normally  
2 terse claim language in order to understand and explain, but not to change, the scope  
3 of the claims.”). But, the plain language of the claims makes clear that the channel  
4 estimate matrices are “based on signals received” (claims 1, 11) or “based on [the /  
5 said] plurality of channel estimates” (claims 21, 22).

6 BNR’s construction also contradicts the specification. The specification  
7 discloses that SVD decomposition is an operation performed *on* a channel estimate  
8 matrix, and not an operation used to *derive* a channel estimate matrix:

9 When computing the SVD a plurality of techniques may be  
10 utilized in performing SVD reduction *on the full channel  
estimate matrix*.

11 ’450 at 8:49-52; Ex. C (Min Op. Decl.) at ¶ 153. In “equation [2],” the ’450 patent  
12 discloses that a singular value decomposition factors a channel estimate matrix  $H_{est}$   
13 into the product of the three matrices  $U$ ,  $S$ , and  $V^H$ . ’450 at 8:52-65. BNR’s proposed  
14 construction relies on circular reasoning to construe a channel estimate matrix as  
15 “based on an SVD decomposition” of the channel estimate matrix itself. Nowhere in  
16 the specification is a channel estimate matrix defined to have such a meaning.

17 Plaintiff’s proposed construction also deviates from the understanding that a  
18 person of ordinary skill would attribute to the terms. “Singular value decomposition  
19 is an operation that you perform on [a] channel estimate matrix.” Ex. F (Min Dep.  
20 Tr.) at 79:8-10. Furthermore, a person of ordinary skill would know that the three  
21 matrices derived from an SVD decomposition of a matrix  $H(t)$  are not “channel  
22 estimate matrices.” Ex. D (Min Reb. Decl.) at ¶ 57.

23 Dr. Madisetti criticizes the use of the notation “ $H_{est}$ ” in Defendants’ proposed  
24 construction because “the patent also used  $H_{up}$  and  $H_{down}$  to describe a ‘channel  
25 estimate matrix.’” Ex. E (Madisetti Reb. Decl.) at ¶ 76. However, “[i]t is often the  
26 case that different claims are directed to and cover different disclosed  
27 embodiments.” *Helmsderfer v. Bobrick Washroom Equip., Inc.*, 527 F.3d 1379,  
28

1 1383 (Fed. Cir. 2008). In the '450 patent,  $H_{est}$  is the only notation used (*i.e.*,  
2 “equation [2]”) to describe a “channel estimate matrix which is computed by a  
3 receiving mobile terminal” as required by the claim language. '450 at 8:52-65; Ex.  
4 D (Min Reb. Decl.) at ¶ 59. The specification uses the notation  $H_{up}$  and  $H_{down}$  to  
5 distinguish a “reverse channel estimate matrix,  $H_{up}$ ” (for a channel where signals are  
6 received by a base station from a mobile terminal) from a “forward channel estimate  
7 matrix,  $H_{down}$ ” (for a channel where signals are received by a mobile terminal from a  
8 base station). '450 at 4:66-5:7; Ex. D (Min Reb. Decl.) at ¶ 59. But, the up/down  
9 notation is not relevant to the construction of the terms here for two reasons. *August*  
10 *Tech. Corp. v. Camtek, Ltd.*, 655 F.3d 1278, 1285 (Fed. Cir. 2011) (“The mere fact  
11 that there is an alternative embodiment disclosed in the asserted patent that is not  
12 encompassed by our claim construction does not outweigh the language of the  
13 claim, especially when the court’s construction is supported by the intrinsic  
14 evidence.”). First, the claim language specifically limits the channel estimate  
15 matrices “based on signals received by a mobile terminal from a base station” (*i.e.*,  
16 based on signals received on a forward channel). Ex. D (Min Reb. Decl.) at ¶ 59. In  
17 other words, the  $H_{up}$  notation is not relevant because the claims are not directed to a  
18 **reverse** channel where an estimate is based on signals received by a **base station**.  
19 And, second, the  $H_{down}$  notation is not relevant because it is only used in the context  
20 of embodiments in which an  $H_{down}$  channel estimate matrix is **computed by the**  
21 **transmitting mobile terminal** and then sent to the receiving mobile terminal. Ex. D  
22 (Min Reb. Decl.) at ¶ 59 (citing '450 at 5:1-7, 8:12-15, 10:20-25, 14:46-49). But the  
23 claims are specifically directed to a channel estimate matrix **computed based on**  
24 **signals received by the receiving mobile terminal**, not a channel estimate matrix  
25 that is sent to the receiving mobile terminal.

26 Defendants’ proposed construction is supported by the patent and by the  
27 understanding of a person of ordinary skill. BNR’s proposed construction, on the  
28

1 other hand, deviates from the patent, including incorrectly incorporating an SVD  
 2 operation. Accordingly, the Court should construe the terms to mean “matrix  $H_{est}$   
 3 for tones of different frequencies, where  $H_{est}$  contains estimates of the true values of  
 4  $H(t)$ .” Ex. C (Min Op. Decl.) at ¶ 155; Ex. D (Min Reb. Decl.) at ¶ 60.

5 **D. “coefficients derived from performing a singular value matrix  
 6 decomposition (SVD)”**

Defendants’ Construction	BNR’s Construction
“values in the matrices U, S, or $V^H$ , where $H_{est}=USV^H$ ”	Plain and ordinary meaning.  In the alternative, to the extent the Court determines that a specific construction is warranted, BNR proposes: “values derived from a singular value decomposition”

7  
 8  
 9  
 10  
 11  
 12  
 13 The parties dispute similarly recited terms in each of the four independent  
 14 claims. Claims 1, 11, and 22 recite “coefficients derived from performing a singular  
 15 value matrix decomposition (SVD),” and claim 21 recites “coefficients from  
 16 performing a singular value matrix decomposition (SVD).”

17 The claims recite a receiving mobile terminal that performs a singular value  
 18 decomposition (SVD) to obtain coefficients that are then transmitted as feedback  
 19 information. As explained above, a receiving mobile terminal uses singular value  
 20 decomposition (SVD) to decompose a channel estimate matrix  $H_{est}$ , into the product  
 21 of three other matrices, namely the matrices U, S, and  $V^H$ . ’450 at 8:52-65; Ex. C  
 22 (Min Op. Decl.) at ¶ 46; Ex. D (Min Reb. Decl.) at ¶¶ 53, 57.

23 The specification supports Defendants’ proposed construction. The  
 24 specification consistently describes the claimed SVD operation in terms of  
 25 performing an SVD on the “channel estimate matrix” and in terms of performing the  
 26 SVD specified by “equation [2].” ’450 at 7:67-8:5, 8:52-65, 9:21-24, 9:37-42; Ex. C  
 27 (Min Op. Decl.) at ¶ 158. Specifically, the patent discloses a receiving mobile  
 28 terminal that “perform[s] SVD reduction on the full channel estimate matrix.” ’450

1 at 8:49-52; Ex. C (Min Op. Decl.) at ¶ 158. The “channel estimate matrix which is  
 2 computed by a receiving mobile terminal,” as required by the claims, is identified by  
 3 the patentee using the notation  $H_{est}$ , as explained above. ¶ 450 at 8:52-65; Ex. C  
 4 (Min Op. Decl.) at ¶ 158. And, the mathematical expression for performing a  
 5 singular value decomposition on the channel estimate matrix  $H_{est}$  is set forth by the  
 6 specification in “equation [2]”:

$$H_{est}=USV^H.$$

7  
 8 ¶ 450 at 8:52-65; Ex. C (Min Op. Decl.) at ¶ 159. A person of ordinary skill would  
 9 understand that the matrices U, S, and  $V^H$  include coefficient “values.” ¶ 450 at 9:37-  
 10 42; Ex. C (Min Op. Decl.) at ¶ 159. The specification discloses no other SVD  
 11 operations. Ex. C (Min Op. Decl.) at ¶ 160; *Phillips v. AWH Corp.*, 415 F.3d 1303,  
 12 1315 (Fed. Cir. 2005) (stating that the specification “is the single best guide to the  
 13 meaning of a disputed term” and is usually “dispositive.”).

14 BNR’s proposed construction is not a construction at all. BNR merely  
 15 replaces the word “coefficients” with the word “values” without identifying what  
 16 “values” are derived from performing the singular value decomposition. Ex. C (Min  
 17 Op. Decl.) at ¶ 161. But, as explained above, the specification discloses the use of  
 18 SVD only to derive the coefficient values in matrices U, S, and  $V^H$  from a channel  
 19 estimate matrix  $H_{est}$ .

20 Dr. Madisetti criticizes Defendants’ proposed construction because it “flows”  
 21 from the construction of the “channel estimate matrices” term. Ex. E (Madisetti  
 22 Reb. Decl.) at ¶ 83. But, as explained above,  $H_{est}$  is the only notation used in the  
 23 specification with respect to the claimed embodiments. Ex. D (Min Reb. Decl.) at  
 24 ¶¶ 59, 64.

25 Accordingly, the Court should construe the terms to mean “values in the  
 26 matrices U, S, or  $V^H$ , where  $H_{est}=USV^H$ .” Ex. C (Min Op. Decl.) at ¶ 162; Ex. D  
 27 (Min Reb. Decl.) at ¶ 65.



1 **V. U.S. PATENT NO. 8,416,862**

2 **A. Technology Background**

3 The '862 patent also relates to beamforming in wireless communication  
4 systems. '862 (Doc. No. 1-6) at 1:20-22. "FIG. 6 is a schematic block diagram of a  
5 beamforming wireless communication where  $H=UDV^*$ ."<sup>11</sup> *Id.* at 12:47-51.

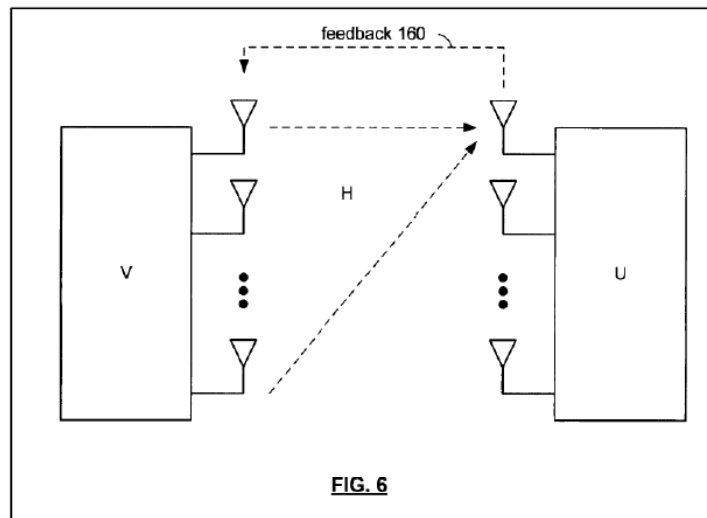

15 According to the specification, a receiving wireless device must provide  
16 feedback information "for a transmitter to properly implement beamforming (i.e.,  
17 determine the beamforming matrix [V])." *Id.* at 3:14-19. This is illustrated as  
18 "feedback 160" in Figure 6.

19 Similar to the '450 patent, the '862 patent discloses that the receiver may use  
20 SVD to decompose a channel estimate matrix (H) to obtain the matrix (V). *Id.* at  
21 3:26-33. The '862 patent further discloses that the receiving wireless device may  
22 then transform the matrix (V) "using a QR decomposition operation such as a  
23

24

25 <sup>11</sup> Both the '450 and the '862 patents disclose that a matrix H may be decomposed  
26 into the product of three other matrices using SVD. However, whereas the '450  
27 patent uses the notation " $V^H$ " for one of the three matrices, the '862 patent uses the  
28 notation " $V^*$ " to represent the same thing. Ex. C (Min Op. Decl.) at ¶¶ 44, 46 n.1;  
Ex. D (Min Reb. Decl.) at ¶ 53 n.1.

1 Givens Rotation operation to produce the transformer beamforming information.”<sup>12</sup>  
 2 *Id.* at Abstract, 3:49-51, 15:34-38. Based on the transmitter beamforming  
 3 information that is fed back, the transmitting wireless device may determine the  
 4 beamforming matrix (V). *Id.* at 10:2-6, 10:59-60.

5 **B. Person of Ordinary Skill in the Art (“POSITA”)**

6 The parties’ experts generally agree on the level of ordinary skill for the ’862  
 7 patent and their opinions are not affected by any differences. Dr. Min states that a  
 8 POSITA would have had a Bachelor’s degree in Electrical Engineering, Computer  
 9 Engineering, Computer Science, or a related field, and at least 2 to 4 years of  
 10 experience in the field of wireless communication, or a person with equivalent  
 11 education, work, or experience in this field. Ex. C (Min Op. Decl.) at ¶¶ 167-69;  
 12 Ex. D (Min Reb. Decl.) at ¶ 66. Dr. Madisetti largely agrees. Ex. A (Madisetti Op.  
 13 Decl.) at ¶ 88.

14 **C. “decompose the estimated transmitter beamforming unitary**  
 15 **matrix (V) to produce the transmitter beamforming information”**

Defendants’ Construction	BNR’s Construction
“factor the estimated transmitter beamforming unitary matrix (V) to produce a reduced set of angles”	Plain and ordinary meaning.  In the alternative, to the extent the Court determines that a specific construction is warranted, BNR proposes: “factor the estimated transmitter beamforming unitary matrix (V) to produce a reduced number of quantized coefficients”

24 Claim 9 of the ’862 patent recites “a baseband processing module operable  
 25 to: . . . decompose the estimated transmitter beamforming unitary matrix (V) to

26 \_\_\_\_\_  
 27 <sup>12</sup> QR decomposition is a linear algebra technique to decompose (factor) a given  
 28 matrix into the product of two other matrices (Q and R). Ex. C (Min Op. Decl.) at ¶ 174.

1 produce the transmitter beamforming information.” The parties agree that the first  
2 part of this term—“decompose the estimated transmitter beamforming unitary  
3 matrix (V) to produce . . .”—should be construed to mean “factor the estimated  
4 transmitter beamforming unitary matrix (V) to produce . . .”. The parties dispute,  
5 however, whether the decomposition operation produces “a reduced number of  
6 quantized coefficients” or “a reduced set of angles.”

7 Claim 9 recites a matrix (V) that is determined based, in part, upon the  
8 “channel response” matrix H. ’862 at 3:30-33 (“H is the channel response.”). The  
9 claim then recites “decompos[ing]” that matrix V “to produce the transmitter  
10 beamforming information” for sending to the transmitting wireless device.

11 Defendants’ proposed construction is supported by the specification. The  
12 specification discloses that the matrix (V) is in the form of polar coordinates (which  
13 includes angles) and decomposition of the matrix (V) produces a reduced set of  
14 angles. ’862 at 9:59-62, 10:2-6; Ex. C (Min Op. Decl.) at ¶ 176. The specification  
15 further discloses that “[t]he receiving wireless device may transform the estimated  
16 transmitter beamforming unitary matrix [(V)] using a QR decomposition operation  
17 such as a Givens Rotation operation to produce the [transmitter] beamforming  
18 information.” ’862 at Abstract; Ex. C (Min Op. Decl.) at ¶ 174 n.6. The term “QR  
19 decomposition . . . refers to a linear algebra technique to decompose a given matrix  
20 into the product of two other matrices (Q and R),” and is also known as “QR  
21 factorization.” Ex. C (Min Op. Decl.) at ¶ 174.

22 The patent explains that the Givens Rotation reduces the number of angles  
23 needed as feedback to the transmitting wireless device. The Givens Rotation  
24 operation is disclosed in Figures 7 and 8. ’862 at 4:15-20; Ex. C (Min Op. Decl.) at  
25 ¶ 175. In describing Figure 7, the specification explains that some of the angles are  
26 redundant. ’862 at 13:65-67; Ex. C (Min Op. Decl.) at ¶ 176. Thus, a reduced set of  
27 angles is produced by decomposing the matrix V:

28

1 With a decomposed matrix form for the estimated  
 2 transmitter beamforming matrix (V), ***the set of angles fed  
 back to the transmitting wireless device are reduced.***

3 '862 at 13:67-14:3. In describing Figure 8, the specification discloses “using a  
 4 Givens Rotation to produce the transmitter beamforming information (step 806).”  
 5 *Id.* at 14:31-36; Ex. C (Min Op. Decl.) at ¶ 177. The specification unequivocally  
 6 confirms that the Givens Rotation produces the “transmitter beamforming  
 7 information” feedback:

8 The products of this Givens Rotation ***are the transmitter  
 9 beamforming information.***

10 '862 at 14:36-37. Indeed, the specification confirms that the transmitter may  
 11 regenerate the V matrix using just the reduced set of angles produced by the Givens  
 12 Rotation. *Id.* at 10:2-6; 10:38-60; Ex. C (Min Op. Decl.) at ¶ 178.

13 The specification further supports the objective to reduce the number of  
 14 angles needed for feedback by reference to a Givens Rotation performed on a  $2 \times 2$   
 15 transmitting beamforming matrix (V). '862 at 14:63-15:8. As shown below, the  
 16 specification discloses a  $2 \times 2$  matrix (V), which includes the following four  
 17 coefficients:

$$18 \cos\psi_1, \cos\left(\frac{\pi}{2} - \psi_1\right), \sin\psi_1 e^{j(\pi+\phi_2)}, \text{ and } \sin\left(\frac{\pi}{2} - \psi_1\right) e^{j\phi_2}.$$

$$19 \quad 20 \quad 21 \quad 22 \quad V = \begin{bmatrix} \cos\psi_1 & \cos\left(\frac{\pi}{2} - \psi_1\right) \\ \sin\psi_1 e^{j(\pi+\phi_2)} & \sin\left(\frac{\pi}{2} - \psi_1\right) e^{j\phi_2} \end{bmatrix}$$

23 '862 at 14:63-15:8; Ex. F (Min Dep. Tr.) at 90:7-25.<sup>13</sup> From this exemplary matrix  
 24 V, the Givens Rotation produces just two angles ( $\psi$  and  $\phi$ ) as the transmitter  
 25 beamforming information.

26 \_\_\_\_\_  
 27 <sup>13</sup> In trigonometry, “cos x” represents the cosine function of an angle x and “sin y”  
 28 represents the sine function of an angle y. Thus, for example, “cos  $\psi_1$ ” represents  
 the cosine of an angle  $\psi_1$ .

$$= \begin{bmatrix} 1 & 0 \\ 0 & e^{j\phi} \end{bmatrix} \begin{bmatrix} \cos\psi & \sin\psi \\ -\sin\psi & \cos\psi \end{bmatrix}$$

'862 at 15:1-8; Ex. F (Min Dep. Tr.) at 90:20-25. Furthermore, a person of ordinary skill would understand that a transmitter can construct the beamforming matrix (V) from just the angles  $\psi$  and  $\phi$ . Ex. F (Min Dep. Tr.) at 103:12-104:2. "If you know those two, you know what V is." *Id.* at 93:14-19.

Plaintiff's proposed construction should be rejected because: (1) it incorporates a quantization operation that is not part of any mathematical decomposition operation, and (2) it fails to recognize the stated objective of the invention to reduce the set of angles. Plaintiff's proposed construction deviates from the claim language by improperly construing the term "decompose" to include a quantization operation. But, according to the claim, "transmitter beamforming information" is produced by "decompos[ing]" the matrix (V), not by quantizing coefficients (or angles). "[D]ecomposition has nothing to do with quantization." Ex. F (Min Dep. Tr.) at 92:17-20. Quantization refers to an operation to transform data into integer values. Ex. C (Min Op. Decl.) at ¶ 180. A person of ordinary skill would understand that neither a Givens Rotation, nor any other QR decomposition operation, produces "quantized" values. *Id.* "The quantization is something that you apply on top of decomposition, [a]fter you decompose using the Givens Rotation." Ex. F (Min Dep. Tr.) at 102:1-3.

Plaintiff's proposed construction also fails to recognize that the Givens Rotation operation produces transmitter beamforming information in the form of angles. As the patent explains, the basis for using a Givens Rotation is to reduce the number of angles needed for the transmitter beamforming information, not coefficients. Ex. C (Min Op. Decl.) at ¶ 180; '862 at 13:65-14:3 ("some of [the] angles of the Givens Rotation are redundant"), 10:2-6 ("The beamforming module 132 determines the beamforming unitary matrix V from feedback information from

1 the receiver, wherein *the feedback information* includes a calculated expression of  
2 the beamforming matrix  $V$  having *polar coordinates*.”). And as Dr. Min explained,  
3 for a  $2 \times 2$  matrix  $V$  the Givens Rotation produces two angles as the transmitter  
4 beamforming information. Ex. C (Min Op. Decl.) at ¶ 178; Ex. F (Min Dep. Tr.) at  
5 90:7-25; *see also* ’862 at 15:38-40 (“For a  $3 \times 3$  estimated transmitter beamforming  
6 matrix ( $V$ ), from Givens Rotation, six angles in total ( $\phi_{22}, \phi_{23}, \phi_{33}, \psi_{12}, \psi_{13}, \psi_{23}$ ) are  
7 required.”); 15:49-51 (“For a  $4 \times 4$  estimated transmitter beamforming matrix ( $V$ ,”  
8 twelve angles are required.).

9 Accordingly, the Court should reject Plaintiff’s proposed construction and  
10 construe the disputed terms to mean “factor the estimated transmitter beamforming  
11 unitary matrix ( $V$ ) to produce a reduced set of angles.” Ex. C (Min Op. Decl.) at  
12 ¶ 181; Ex. D (Min Reb. Decl.) at ¶ 70.

## 13 **VI. U.S. PATENT NO. 6,941,156**

### 14 **A. Technology Background**

15 The ’156 patent is directed to inter-technology handovers by “transferring a  
16 communication link between two different modes of a multimode cell phone.” ’156  
17 (Doc. No. 15-6) at Abstract. The specification discloses that the “invention  
18 generally relates to piconet wireless networks,” and “[m]ore particularly . . . to the  
19 use of a combination 3-in-1 cell phone/cordless telephone/walkie-talkie device.”  
20 ’156 at 1:6-10.

### 21 **B. Person of Ordinary Skill in the Art (“POSITA”)**

22 The parties’ experts generally agree on the level of ordinary skill for the ’156  
23 patent and their opinions are not affected by any differences. Dr. Min states that a  
24 POSITA would have had a Bachelor’s degree in Electrical Engineering, Computer  
25 Engineering, Computer Science, or a related field, and at least 2 years of experience  
26 in the field of wireless communication, or be a person with equivalent education,  
27 work, or experience in this field. Ex. C (Min Op. Decl.) at ¶¶ 70-73; Ex. D (Min  
28

1 Reb. Decl.) at ¶ 20. Dr. Madisetti largely agrees. *Id.* (“a bachelor’s degree in  
 2 electrical engineering, computer engineering, computer science or similar field, and  
 3 two to three years of experience in digital communications systems, such as wireless  
 4 communications systems and networks, or equivalent.”); Ex. A (Madisetti Op.  
 5 Decl.) at ¶ 45.

6 **C. “simultaneous communication paths from said multimode cell  
 7 phone” (cl. 1)**

Defendants’ Construction	BNR’s Construction
“at least two established distinct and different communication links from said multimode cell phone to a far-end communication device, at the same time”	Plain and ordinary meaning.  In the alternative, to the extent the Court determines that a specific construction is warranted, BNR proposes: “two or more active links at the same time from said multimode cellphone”

14 The term “simultaneous communication paths from said multimode cell  
 15 phone” should be construed to mean “at least two established distinct and different  
 16 communication links from said multimode cell phone to a far-end communication  
 17 device, at the same time” as proposed by Defendants. To provide context, the claim  
 18 limitation at issue recites:

19 a module to establish simultaneous communication paths from said  
 20 multimode cell phone using both said cell phone functionality and said RF  
 21 communication functionality

22 ’156 at 8:19-22.

23 Moreover, the term “simultaneous communication paths from said multimode  
 24 cell phone” as used in the claims is understandable to a person of ordinary skill in  
 25 the art to mean “at least two established distinct and different communication links  
 26 from said multimode cell phone to a far-end communication device, at the same  
 27 time.” Ex. C (Min Op. Decl.) at ¶ 77. This is well-described within the ’156 patent  
 28 specification, and Federal Circuit precedent is clear that the specification is always

1 “highly relevant” to claim construction analysis and is the “single best guide to the  
2 meaning of a disputed term.” *Phillips*, 415 F.3d at 1315 (quoting *Vitronics Corp. v.*  
3 *Conceptronic, Inc.*, 90 F.3d 1576, 1582 (Fed. Cir. 1996) (quotation marks omitted)).  
4 As confirmed by Defendants’ expert, Dr. Min, the ’156 patent explains that a  
5 handover between modes is made possible while the multimode cell phone is on a  
6 call (using one mode) by the multimode cell phone’s simultaneous operation (in  
7 another mode) to establish a secondary “communication link therebetween” the two  
8 parties. *See* Ex. C (Min Op. Decl.) at ¶ 79. The ’156 specification describes this as:

9           Preferably, more than one mode of the multimode cell phone **100**  
10           may operate simultaneously, allowing the establishment of a secondary  
11           communication path in the background, allowing easy and quick switch  
12           over as desired or required. For instance, while operating in a cell  
13           phone mode, the automatic switch over module **101** of the multimode  
14           cell phone **100** may detect walkie-talkie communication activity from  
15           the far party’s multimode cell phone **100**, and ***establish a***  
16           ***communication link therebetween*** even while the two parties remain  
17           in a cell phone conversation.

18           ’156 at 3:64-4:6 (emphasis in original (bold) and added (bold italics)). The  
19           specification further explains that “[b]y automatically changing the mode of the  
20           multimode cell phone **100** (preferably subsequent to a prompt to the user for  
21           permission to transfer), the conversation or other communication between the  
22           parties is transferred to the newly established cell phone call.” *Id.* at 4:23-27; Ex. C  
23           (Min Op. Decl.) at ¶ 79.

24           Defendants’ proposed construction is also supported by ’156 Fig. 1, which  
25           depicts the “initial telephone call” and the “handed over telephone call” as separate  
26           and unique arrows (*i.e.*, “distinct and different communication links”) to “far end  
27           telephone 150” (*i.e.*, “far-end communication device”). A person of ordinary skill in  
28           the art would also understand ’156 Fig. 1 to support Defendants’ proposed  
          construction. *See* Ex. C (Min Op. Decl.) at ¶ 80.



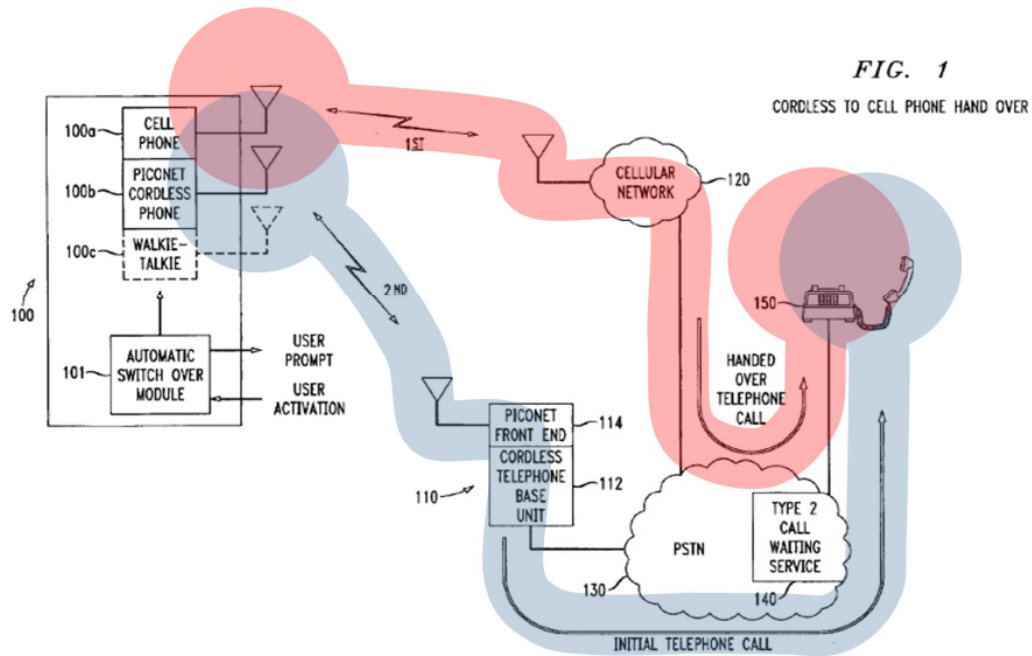

FIG. 1

CORDLESS TO CELL PHONE HAND OVER

1  
2  
3  
4  
5  
6  
7  
8  
9  
10  
11  
12  
13  
14  
15  
16  
17  
18  
19  
20  
21  
22  
23  
24  
25  
26  
27  
28

*Id.* at Fig. 1 (annotated to show the two established different and distinct communications links from the multimode cell phone to a far-end communication device). The paths depicted by arrows in '156 Fig. 3 and Fig. 5 similarly show such distinct and different communication links.

The '156 patent discloses three exemplary processes for handing over a telephone call between modes. *See* '156 Fig. 2 (handing over a telephone call from the cordless mode to a cellular mode), Fig. 4 (handing over a walkie-talkie conversation to a cellular telephone call), and Fig. 6 (handing over a walkie-talkie conversation to a cordless telephone call). *See also* Ex. C (Min Op. Decl.) at ¶¶ 81, 82.

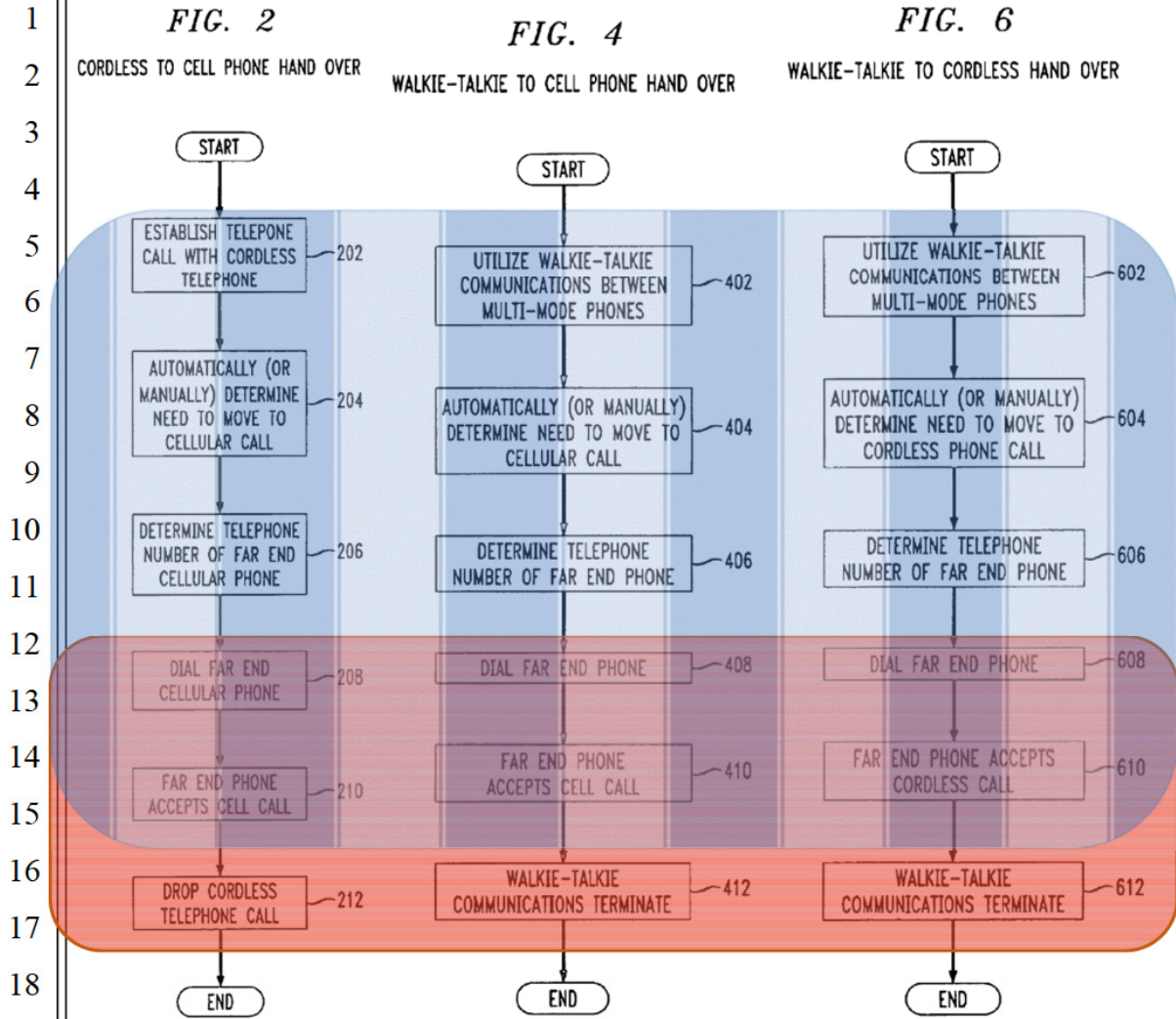

In *each* of these exemplary processes, during an established telephone call (*id.* at Fig. 2 (202)) or walkie-talkie conversation (*id.* at Fig. 4 (402) or Fig. 6 (602)), a “far end cellular phone” or “far end phone” is dialed (*id.* at Fig. 2 (208), at Fig. 4 (408), at Fig. 6 (608)) and the “far end phone accepts [the cell or cordless] call” (*id.* at Fig. 2 (210), at Fig. 4 (410), at Fig. 6 (610)) *before* the initially-established telephone call is dropped (*id.* at Fig. 2 (212)) or walkie-talkie communications terminate (*id.* at Fig. 4 (412) and Fig. 6 (612)). Thus, between when the “far end phone accepts [the cell or cordless] call” and when the initially-established telephone call is dropped or walkie-talkie communications terminate, there are “at

1 least two established distinct and different communication links from said  
2 multimode cell phone to a far-end communication device, at the same time.” *See*  
3 *also* Ex. C (Min Op. Decl.) at ¶¶ 82, 83. This can be seen in the annotated figures  
4 above where the initially-established call or communication is shown in blue  
5 vertical stripes, and the dialing and establishment of the far end phone is shown in  
6 red horizontal stripes, with the period when both links are established shown in  
7 purple cross-hatch (due to the simultaneous links). Thus, the patent confirms that  
8 the simultaneous links are established using different modes of the multimode  
9 cellphone.

10 Additionally, the ’156 specification even describes that the initial  
11 communication path may be maintained for a period of time after the handover.  
12 ’156 at 5:4-6 (“In step 212, the old communication path (in this case the cordless  
13 telephone call) is dropped, perhaps after a desirable delay (e.g., after 5 seconds”).  
14 This delay period may even be increased, to facilitate a switchover back to the initial  
15 communication path if the switchover does not succeed. *Id.* at 6:41-44 (“[i]n the  
16 unlikely event that the switchover does not succeed, the switchover is preferably  
17 delayed (e.g., for 10 seconds or more) to allow the users to switch back to the initial  
18 telephone call or communication path”). *See also* Ex. C (Min Op. Decl.) at ¶ 84.  
19 This supports Defendants’ proposed construction that the simultaneous links are to a  
20 far-end communication device.

21 The specification disclosure (at 3:29-33) that Call Waiting is used “to switch  
22 the far end telephone from one line to the other” further supports Defendants’  
23 construction. Dr. Min has also explained that “[a] POSITA would understand that  
24 the specification is explaining that Call Waiting is used by the far end telephone  
25 device to switch between two established distinct and different communication links  
26 from said multimode cell phone to a far-end communication device.” Ex. C (Min  
27 Op. Decl.) at ¶ 85.

28

1 BNR’s proposed construction of “two or more active links at the same time  
2 from said multimode cellphone” 1) fails to account for the ’156 patent’s disclosure  
3 that the claimed invention is directed to handovers between different modes of a  
4 multimode cell phone, as discussed above; 2) is confusing inasmuch as it uses but  
5 does not explain the meaning of the term “active” (which could have several  
6 meanings to a POSITA); 3) provides no basis to ascertain both end points of the  
7 “simultaneous communication path” which a POSITA would recognize as necessary  
8 to define a “communication path”; and 4) conflicts with the prosecution history of  
9 the ’156 patent. *See* also Ex. C (Min Op. Decl.) at ¶¶ 86-91; Ex. D (Min Reb. Decl.)  
10 at ¶¶ 22-24.

11 As confirmed by Defendants’ expert Dr. Min, “an active link” could have at  
12 least two meanings to a POSITA: (1) “a link maintaining transmission and reception  
13 of data”; and (2) “a link simply maintaining the connected state without transmitting  
14 and receiving data.” Ex. C (Min Op. Decl.) at ¶ 86. With respect to the latter  
15 meaning, “[a] POSITA would have known that a multimode cell phone could be  
16 connected to another device without exchanging data for a certain period of time  
17 before it is timed out.” *Id.* This lack of clarity is problematic.

18 Additionally, a POSITA would understand that a communication path must  
19 have two end-points, one at the multimode cell phone and another at a far-end  
20 communication device. Ex. C (Min Op. Decl.) at ¶ 87. Defendants’ proposed  
21 construction is consistent with the ’156 specification’s disclosure that the  
22 communication path is from “said multimode cell phone to a far-end communication  
23 device,” as discussed above.

24 The conflict with the prosecution history is problematic, as applicant  
25 expressly amended the claims and made arguments during prosecution of the  
26 application that became the ’156 patent to overcome an Office Action rejecting all  
27 original claims as anticipated by U.S. Patent No. 5,842,122 to Schellinger et al.  
28

1 (“Schellinger”). *See* Ex. G (prosecution history excerpt: Office Action mailed Dec.  
2 8, 2004 (BNR-SDCA00000059–66)). This amendment and argument contradicts  
3 BNR’s construction. “Any explanation, elaboration, or qualification presented by  
4 the inventor during patent examination is relevant, for the role of claim construction  
5 is to ‘capture the scope of the actual invention’ that is disclosed, described, and  
6 patented.” *Fenner Invs., Ltd. v. Cellco P’ship*, 778 F.3d 1320, 1323 (Fed. Cir.  
7 2015). “[T]he interested public has the right to rely on the inventor’s statements  
8 made during prosecution without attempting to decipher whether the examiner relied  
9 on them or how much weight they were given.” *Id.* at 1325. “[T]he prosecution  
10 history (or file wrapper) limits the interpretation of claims so as to exclude any  
11 interpretation that may have been disclaimed or disavowed during prosecution in  
12 order to obtain claim allowance.” *Standard Oil Co. v. Am. Cyanamid Co.*, 774 F.2d  
13 448, 452 (Fed. Cir. 1985); *see also Tech. Props. Ltd. LLC v. Huawei Techs. Co.,*  
14 *Ltd.*, 849 F.3d 1349, 1359 (Fed. Cir. 2017) (finding disclaimer and explaining “we  
15 hold patentees to the actual arguments made, not the arguments that could have been  
16 made”).

17 Schellinger discloses an “automatic handoff operation” when portable cellular  
18 cordless (PCC) radiotelephone 101 “moves out of range of the cordless telephone  
19 system and is in the coverage area of the cellular telephone system.” Schellinger at  
20 6:61-7:6, 7:50-8:3:

21 In accordance with the preferred embodiment of the present  
22 invention, a call in process between the PCC 101 operating in a cellular  
23 telephone system 103 and a calling party is handed off from the cellular  
24 telephone system 103 to the cordless telephone system by producing a  
25 three way call through the cellular telephone system 103, at block 716,  
between the PCC 101, the other party and the landline phone number  
of the cordless base station 115.

26 In FIG. 6-2 the cordless base station 115 receives the handoff  
27 from cellular to cordless request at block 617 and answers the landline  
28 leg of the three way call at block 619 to open communication between  
the other party and the cordless base station 115. The PCC 101 is now

1 in a cordless phone call with the calling party at block 621. In FIG. 7A  
2 the PCC 101 operating in the cellular telephone system 103 ends the  
3 cellular leg of the three way call at block 718 to terminate cellular  
4 system communication between the PCC 101 and the other party. Thus,  
5 a call in process is handed off from the cellular telephone system 103  
6 to the cordless telephone system when the PCC 101 relocates from the  
7 cellular telephone system 103 to the cordless telephone system.

8 Applicant amended the claims to overcome Schellinger, adding to claim 1 “a  
9 module to establish simultaneous communication paths from said multimode cell  
10 phone using both said cell phone functionality and said RF communication  
11 functionality.” *See* Ex. H (prosecution history excerpt: Response to Office Action  
12 filed January 6, 2005 (BNR-SDCA00000073)) at 2. Applicant argued that  
13 “Schellinger discloses a dual mode cellular cordless portable radiotelephone that is  
14 capable of ONE mode of communication, or the OTHER, BUT NOT BOTH  
15 SIMULTANEOUSLY.” *See* Ex. H (prosecution history excerpt: Response to Office  
16 Action filed January 6, 2005 (BNR-SDCA00000078)) at 7 (emphasis in original).  
17 The applicant also argued that:

18 according to Schellinger, **automatic forwarding** systems **of a**  
19 **central office** are implemented to allow handoff of a call. . . a call in  
20 process if handed off by producing a THREE WAY CALL **through the**  
21 **cellular telephone system** (i.e., NOT through the cell phone itself). To  
22 finally implement the handoff, the cell phone switches to a landline leg  
23 of a **three way call** (set up by a central office and/or cellular telephone  
24 system), and the initial call is dropped.

25 *See id.* at 8 (BNR-SDCA00000079) (emphasis in original).<sup>14</sup>

26 However, as discussed by Dr. Min, a POSITA would understand that the three  
27 way call disclosed by Schellinger reflected two links from the radiotelephone to the  
28 telephone network: one link from the radiotelephone that terminated at the cellular

---

<sup>14</sup> The examiner allowed the amended claims in response to applicant’s arguments. *See* Ex. I (prosecution history excerpt: Notice of Allowance mailed Apr. 26, 2005 (BNR-SDCA00000084)).

1 telephone system, and another link from the radiotelephone's cordless base station  
2 that terminated at a central office and/or cellular telephone system. *See* Ex. C (Min  
3 Op. Decl.) at ¶¶ 90-91; Ex. D (Min Reb. Decl.) at ¶¶ 24. Thus, BNR's proposed  
4 construction of "two or more active links at the same time from said multimode  
5 cellphone" would encompass communication paths that terminate at the telephone  
6 network, just as Schellinger disclosed and against which applicants explicitly  
7 distinguished. Thus applicants explicitly disavowed claim scope that would  
8 encompass handovers produced by "a three way call through the cellular telephone  
9 system." BNR's proposed construction therefore cannot be correct, as it is  
10 unsupported.

11 In contrast, Defendants' construction has no such issues as it clarifies that the  
12 handover is accomplished by two distinct and different links to the far-end  
13 communication device (and not a three way call through the telephone system (*i.e.*,  
14 two links to the telephone system)). Indeed, the Examiner's rejection stated that  
15 "Schellinger teaches . . . an automatic switch over module . . . operable to switch *a*  
16 *communication path established on one* of said cell phone functionality and said  
17 RF communication *functionality, with another communication path later*  
18 *established on the other* of said cell phone functionality and said RF  
19 communication *functionality.*" *See* Ex. G (prosecution history excerpt: Office  
20 Action mailed Dec. 8, 2004 (BNR-SDCA00000061)) at 2-3 (emphasis added).  
21 BNR appears to be wholesale importing limitations from a different *method* claim,  
22 independent claim 4, which explicitly recites "[a] method of . . . establishing from  
23 said multimode cell phone said *second type* RF *communication link while said first*  
24 *type* RF *communication link* remains active at said multimode cell phone" ('156 at  
25 8:47-50, emphasis added), despite not asserting independent claim 4 or any of its  
26 dependent claims 5-10 against any of the Defendants. Accordingly, Defendants  
27 respectfully submit that the term "simultaneous communication paths from said  
28

1 multimode cell phone” be construed as “at least two established distinct and  
 2 different communication links from said multimode cell phone to a far-end  
 3 communication device, at the same time,” as supported by the ’156 specification and  
 4 prosecution history disclosure, and as would be understood by a person of ordinary  
 5 skill in the art.

6 **D. “a module to establish simultaneous communication paths from**  
 7 **said multimode cell phone using both said cell phone functionality and**  
 8 **said RF communication functionality” (cl. 1)**

9 **1. This Term Is Subject to § 112 ¶ 6 (Means-Plus-Function)**

Defendants’ 112 ¶ 6 Contention	BNR’s 112 ¶ 6 Contention
This is a 112 ¶ 6 claim element.	Not a 112 ¶ 6 claim element – “module” is not a nonce word here. Instead, the “module to establish simultaneous communication paths from said multimode cell phone using both said cell phone functionality and said RF communication functionality” is itself sufficient structure. A POSA would know this is a structure for RF communications through a genus of RF communication types well known in the art.

17 As an initial matter, *all Defendants agree* this term is *subject to 112 ¶ 6*  
 18 because it uses the nonce word “module” and “recites function” (*i.e.*, “establish[ing]  
 19 simultaneous communication paths . . .”) “without reciting sufficient structure for  
 20 performing that function.” *Williamson v. Citrix Online, LLC*, 792 F.3d 1339, 1348,  
 21 1350 (Fed. Cir. 2015). The intrinsic evidence supports this conclusion.

22 Starting with the claim language, this term recites a “module” “to establish  
 23 simultaneous communication paths . . . .” The term “module” is a generic term that  
 24 lacks structure. *Williamson*, at 1350 (“‘Module’ is a well-known nonce word that  
 25 can operate as a substitute for ‘means’ in the context of § 112, para. 6. . . .  
 26 ‘[M]odule’ is simply a generic description for software or hardware that performs a  
 27 specified function.”). The remainder of the term also lacks structure, as it solely  
 28



1 describes the function of the module (“to establish simultaneous communication  
2 paths . . .”), but provides no structure to do so.

3 Turning next to the intrinsic evidence, it reiterates the function and points to  
4 the “automatic switch over module 101,” which purports to perform the function of  
5 establishing simultaneous communication paths. The other references to the  
6 automatic switch over module are similar:

7 “Preferably, more than one mode of the multimode cell phone 100 may  
8 operate *simultaneously*, allowing the establishment of a secondary  
9 communication path in the background, allowing easy and quick switch over  
10 as desired or required. For instance, while operating in a cell phone mode, the  
11 *automatic switch over module 101* of the multi mode cell phone 100 may  
12 detect walkie-talkie communication activity from the far party’s multimode  
13 cell phone 100, and *establish a communication link therebetween even while*  
14 *the two parties remain in a cell phone conversation.*” ’842 at 4:1-6  
15 (emphasis added).

12 “An *automatic switch over module* is in communication with both the cell  
13 phone functionality and the RF communication functionality. The *automatic*  
14 *switch over module* operates to switch a communication path established on  
15 either the cell phone functionality or the RF communication functionality,  
16 with another communication path established on the other of the cell phone  
17 functionality and the RF communication functionality.” ’842 at 1:54-61  
18 (emphasis added).

16 “Importantly, an *automatic switch over module 101* is in communication with  
17 each communication path functionality, e.g., with the cell phone functionality  
18 100a, the piconet cordless telephone functionality 100b, and the walkie-talkie  
19 functionality 100c.” ’842 at 3:56-60 (emphasis added).

19 Automatic switch over module 101 is also depicted in FIG. 1, which similarly  
20 provides a black box with the same words:

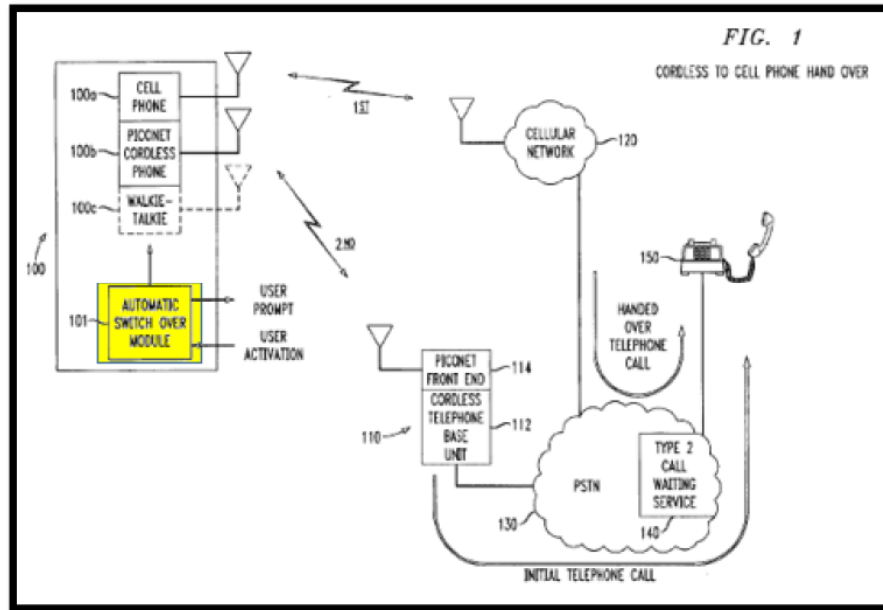

The prosecution history further echoes the above: applicant distinguished this limitation from the prior art by its function only, not by any sort of distinguishing structure. Ex. J (Wells Op. Decl.) at Ex. E ('156 file history excerpt) at 8 (stating that the asserted prior art reference “fails to disclose simultaneous communication paths from a multimode cell phone”).

Further, like the claim at issue in *Williamson*, although portions of this term “describe certain inputs and outputs at a very high level” (e.g., cell phone functionality and RF communication functionality), neither the term (nor the claim) describes how the module interacts with other components in the multimode cell phone in a way that imparts structure to this claim term. 792 F.3d at 1351.

BNR asserts that this term is not subject to 112 ¶ 6 because, according to its expert, “a POSITA, viewing the term in light of the specification, would understand that it refers to a class of structures within multimode cell phones that negotiate and control each of the modes of communication, namely cellular, RF communication (other than cellular) including piconet, walkie-talkie, and such genus of RF communications.” Ex. A (Madisetti Op. Decl.) at ¶ 5. BNR’s expert supports his

1 statement by generally referencing various technologies disclosed in the  
 2 specification—but fails to point to any evidence that connects that technology with  
 3 “establish[ing] simultaneous communication paths from said multimode cell phone  
 4 using both said cell phone functionality and said RF communication functionality,”  
 5 as the functional language requires. *See, e.g.*, Ex. A (Madisetti Op. Decl.) at ¶¶ 59-  
 6 60. In short, BNR fails to identify any structure for the module’s functional  
 7 language. Thus, the claim term is properly analyzed as being a means-plus-function  
 8 limitation.

9 **2. Corresponding Function and Structure**

Huawei & Coolpad’s Proposed Function & Structure	BNR’s Alternative Construction
<p>12 <u>Function</u>: “establish simultaneous communication paths from said multimode cell phone using both said cell phone functionality and said RF communication functionality”</p> <p>13</p> <p>14</p> <p>15</p> <p>16</p> <p>17</p> <p>18</p> <p>19 <u>Structure</u>: Fig. 1 (element 101); Fig. 2 steps 202-208; Fig. 4 steps 402-408; 4:50-67; 7:1-16.</p>	<p>12 In the alternative, to the extent the Court determines that this claim is governed by 112 ¶ 6, BNR proposes the following Function and Structure, and disagrees that the term is indefinite for lack of corresponding structure:</p> <p>13</p> <p>14</p> <p>15</p> <p>16 <u>Function</u>: establish simultaneous communication paths from said multimode cell phone using both said cell phone functionality and said RF communication functionality</p> <p>17</p> <p>18</p> <p>19 <u>Structure</u>: Corresponding structure for the alleged function exists in at least the following portions of the patent specification, or their equivalents: Figs. 1, 3, Col. 3:48–4:49; 4:54–5:62; 6:3–55; 6:60–8:5</p>

23 Applying 112 ¶ 6, *all Defendants agree* that the *corresponding function* for  
 24 this term is, as stated in the limitation, “establish simultaneous communication paths  
 25 from said multimode cell phone using both said cell phone functionality and said RF  
 26 communication functionality.” This matches BNR’s alternative construction.

1           Regarding *the corresponding structure*, to the extent the Court does not agree  
2 with ZTE and Kyocera that this term is indefinite for a lack of structure, *Huawei*  
3 *and Coolpad* first note that since the “module to establish simultaneous  
4 communication paths” limitation is a processor-implemented means, the  
5 corresponding structure must include an algorithm performed by a processor to  
6 accomplish the recited function. *Williamson*, 792 F.3d at 1352 (“In cases such as  
7 this, involving a claim limitation that is subject to § 112, para. 6 that must be  
8 implemented in a special purpose computer, this court has consistently required that  
9 the structure disclosed in the specification be more than simply a general purpose  
10 computer or microprocessor. We require that the specification disclose an algorithm  
11 for performing the claimed function.”); *In re Aoyama*, 656 F.3d 1293, 1297 (Fed.  
12 Cir. 2011); *WMS Gaming Inc. v. Int’l Game Tech.*, 184 F.3d 1339, 1349 (Fed. Cir.  
13 1999). BNR does not appear to dispute that this module is implemented by a  
14 processor. *See, e.g.*, Ex. A (Madisetti Op. Decl.) at ¶ 66 (referencing the “software  
15 and hardware” that perform this function), ¶ 64 (stating that an example of the  
16 module is “an integrated circuit”). According to the Federal Circuit, “[t]he  
17 algorithm may be expressed as a mathematical formula, in prose, or as a flow chart,  
18 or in any other manner that provides sufficient structure.” *Williamson*, 792 F.3d at  
19 1352.

20           For purposes of identifying the corresponding structure, this term is best  
21 considered in conjunction with the next term (the “automatic switch over module  
22 ...”). These two limitations split a handover process into two sequential parts, where  
23 the “module to establish simultaneous communication paths” acts before the  
24 “automatic switch over module.” For example, the “automatic switch over module”  
25 uses the term “established” (past tense) to refer to the communication paths that are  
26 being switched—meaning that, after the simultaneous communication paths have  
27 been “established” (by the “module to establish simultaneous communication  
28

1 paths”), the switching between the communication paths occurs (function of the  
2 “automatic switch over module”).

3 The ’156 specification discloses flow charts in FIG. 2, steps 202-208 and FIG.  
4 4, steps 402-408 that the “multimode cell phone 100” and its “automatic switch over  
5 module 101” perform to establish simultaneous communication paths and perform  
6 the hand over. ’156 at 3:49-4:6, 4:50-5:6, 7:1-26, FIGS. 2, 4. The figures depict  
7 hand overs from cordless to cell phone (FIG. 2) and from walkie-talkie to cell phone  
8 (FIG. 4) and the patent describes that these algorithms can be applied in the  
9 converse scenarios (*i.e.*, from cell phone to cordless; from cell phone to walkie-  
10 talkie). ’156 at 3:64-4:6, 5:8-20, 6:60-67. Because this limitation requires  
11 “establish[ing] simultaneous communication paths . . . ,” but not performing the  
12 “automatic switch over,” only the first four steps of the flow charts correspond to  
13 this limitation, as indicated below:

14  
15  
16  
17  
18  
19  
20  
21  
22  
23  
24  
25  
26  
27  
28

1  
2  
3  
4  
5  
6  
7  
8  
9  
10  
11  
12  
13  
14  
15  
16  
17  
18  
19  
20  
21  
22  
23  
24  
25  
26  
27  
28

**FIG. 2**  
CORDLESS TO CELL PHONE HAND OVER

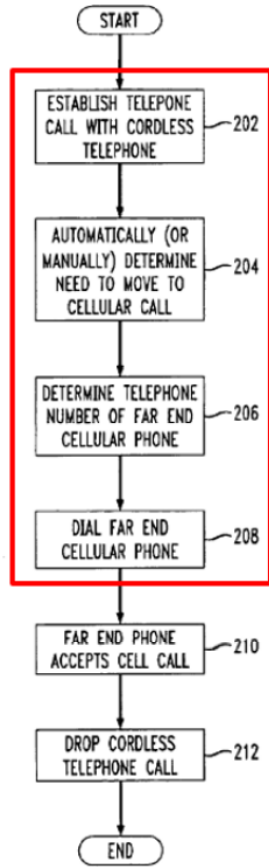

**FIG. 4**  
WALKIE-TALKIE TO CELL PHONE HAND OVER

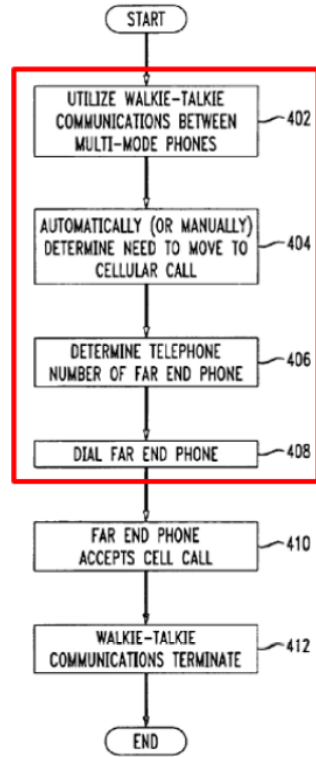

These steps are described at 4:50-67 (steps 202-208) and 7:1-16 (steps 402-408). Accordingly, the corresponding structure for this limitation is: Fig. 1 (element 101); Fig. 2 steps 202-208; Fig. 4 steps 402-408; 4:50-67; 7:1-16.<sup>15</sup>

BNR’s proposed corresponding structure is, by contrast, untethered to this limitation. It is not an algorithm, and instead encompasses a large swath of the specification (more than four full columns of the less-than-six-column “Detailed Description of Illustrative Embodiments”). And BNR’s proposed structure for this

<sup>15</sup> Although FIG. 6 also discloses an algorithm, it is not corresponding structure here because the hand over depicted in FIG. 6 does not include a cell phone, while a “cell phone functionality” is specifically recited in this limitation.

1 term is identical to its proposed structure for the “automatic switch over module”  
 2 discussed below. Further, BNR has identified the entirety of FIGS. 1 and 3,  
 3 apparently contending that the corresponding structure includes a “Cellular  
 4 Network,” a far end phone, and numerous other components. Because infringement  
 5 of means-plus-function limitations turns on whether BNR proves that the accused  
 6 products have structure equivalent to that of the limitation (*Tomita Techs. USA, LLC*  
 7 *v. Nintendo Co.*, 681 F. App’x 967, 970 (Fed. Cir. 2017)), BNR dumps the  
 8 proverbial haystack on the Court to let the Court hunt for where it might find  
 9 supporting structure in over 40 paragraphs of text.

10 **E. “an automatic switch over module, in communication with both**  
 11 **said cell phone functionality and said RF communication functionality,**  
 12 **operable to switch a communication path established on one of said cell**  
 13 **phone functionality and said RF communication functionality, with**  
 14 **another communication path later established on the other of said cell**  
 15 **phone functionality and said RF communication functionality” (cl. 1)**

1. This Term Is Subject to § 112 ¶ 6 (Means-Plus-Function)

Defendants’ 112 ¶ 6 Contention	BNR’s 112 ¶ 6 Contention
This is a 112 ¶ 6 claim element.	Not a 112 ¶ 6 claim element – “module” is not a nonce word here. Instead, the “an automatic switch over module, in communication with both said cell phone functionality and said RF communication functionality, operable to switch a communication path established on one of said cell phone functionality and said RF communication functionality, with another communication path later established on the other of said cell phone functionality and said RF communication functionality” is itself sufficient structure. A POSA would know this is a structure for RF communications through a genus of RF communication types well known in the art.

26 The reason that 112 ¶ 6 applies for this term is largely the same as the reason  
 27 112 ¶ 6 applied for the preceding “module” term, so we provide an abbreviated  
 28

1 discussion here. *All Defendants agree* this term is subject to 112 ¶ 6 because it uses  
2 the nonce word “module” and “recites function” (*i.e.*, “operable to switch a  
3 communication path established on one of said cell phone functionality and said RF  
4 communication functionality, with another communication path later established on  
5 the other of said cell phone functionality and said RF communication functionality”)  
6 “without reciting sufficient structure for performing that function.” *Williamson*, 792  
7 F.3d at 1348, 1350.

8       The intrinsic evidence confirms the lack of structure in this limitation. As this  
9 claim states, the module associated with this function is the “automatic switch over  
10 module”—the same box tied to the preceding “module” term. As explained above,  
11 the specification only ever describes the “automatic switch over module” by its  
12 function and depicts it solely as a box with those words (*see* FIG. 1). Further,  
13 although portions of this term “describe certain inputs and outputs at a very high  
14 level” (e.g., cell phone functionality and RF communication functionality), neither  
15 the term (nor the claim) describe how this module interacts with other components  
16 to sufficiently impart structure. *Williamson*, 792 F.3d at 1351. For completeness,  
17 note that, unlike for the preceding “module” term, the prosecution history is silent  
18 on this limitation, as the applicant did not specifically comment on it. *See* Ex. K  
19 (Wells Op. Decl.) at ¶ 100.

20       BNR’s expert makes essentially the same representation for this term as he  
21 did for the preceding “module” term, *i.e.*, that a POSITA would understand this term  
22 “denotes a class of structures that control the radios in the known art of cellular  
23 telephone technology at the time of the invention, including integrated circuits and  
24 the like, and that the term here represents an inventive modification to those known  
25 structures.” Ex. A (Madisetti Op. Decl.) at ¶ 76. BNR’s expert’s statement is  
26 internally inconsistent and unsupported. First, he states that a POSITA would  
27 understand the structure, and then he states that it “represents an inventive  
28



1 modification.” BNR’s expert does not describe the hardware and/or software of the  
 2 purported “inventive modification.” Further, he cites nothing for this assertion,  
 3 apparently relying, instead, on his statements regarding the preceding “module”  
 4 term. They fail here for the same reasons discussed above: none of BNR’s proposed  
 5 structure is tied to the function of this term (“automatic switch over . . .”). And for  
 6 those reasons, again this term is properly analyzed as a means-plus-function  
 7 limitation.

8 **2. Corresponding Function and Structure**

Huawei & Coolpad’s Proposed Function and Structure	BNR’s Alternative Construction
<p>11 <u>Function</u>: “automatic switch                      12 over of a communication path                      13 established on one of said cell                      14 phone functionality and said                      15 RF communication                      16 functionality, with another                      17 communication path later                      18 established on the other of said                      19 cell phone functionality and                      20 said RF communication                      21 functionality”</p> <p>22 <u>Structure</u>: Fig. 1 (element 101);                      23 Fig. 2 steps 210-212; Fig. 4                      24 steps 410-412; 5:1-7; 7:17-26,                      25 claim 1 (“an automatic switch                      26 over module, in                      27 communication with both said                      28 cell phone functionality and                      said RF communication                      functionality”).</p>	<p>In the alternative, to the extent the Court determines that this claim is governed by 112 ¶ 6, BNR proposes the following Function and Structure, and disagrees that the term is indefinite for lack of corresponding structure:</p> <p><u>Function</u>: in communication with both said cell phone functionality and said RF communication functionality, operable to switch a communication path established on one of said cell phone functionality and said RF communication functionality, with another communication path later established on the other of said cell phone functionality and said RF communication functionality</p> <p><u>Structure</u>: Corresponding structure for the alleged function exists in at least the following portions of the patent specification, or their equivalents: Figs. 1, 3, Col. 3:48–4:49; 4:54–5:62; 6:3–55; 6:60–8:5</p>

Applying 112 ¶ 6, *Huawei and Coolpad* agree that the *corresponding function* is “automatic switch over of a communication path established on one of

1 said cell phone functionality and said RF communication functionality, with another  
2 communication path later established on the other of said cell phone functionality  
3 and said RF communication functionality.” This function properly preserves the  
4 “automatic switch over” description of the functionality and, for readability, merely  
5 deletes the redundant clause “in communication with both said cell phone  
6 functionality and said RF communication functionality.”

7       Regarding *the corresponding structure*, to the extent the Court does not agree  
8 with ZTE and Kyocera that this term is indefinite for a lack of structure, *Huawei*  
9 *and Coolpad* first note that, as for the preceding “module” term, this is a processor-  
10 implemented means, such that the corresponding structure must include an  
11 algorithm. *Williamson*, 792 F.3d at 1352. As for the preceding term, BNR appears  
12 to concede that this term is implemented by a processor. *See, e.g.*, Ex. A (Madisetti  
13 Op. Decl.) at ¶ 76 (stating that a POSITA “is aware of the components of a  
14 multimode cellular phone ... and the interaction between [each mode] was  
15 understood in the art to be through *integrated circuitry* interacting with the  
16 transceivers” (emphasis added)); *id.* at ¶ 79 (“A person of ordinary skill in the art  
17 would understand how a multimode cell phone would transmit and receive for each  
18 of these modes and which components would incorporate the inventive additional  
19 functionalities embodied in this claim, and *the particular hardware and software*  
20 *components* are well known in the art of cellular telephone technology.” (emphasis  
21 added)).

22       As explained above, according to claim 1, the “automatic switch over  
23 module” performs the function of “automatic switch over ...” after the simultaneous  
24 communication paths are “established.” The algorithms in FIG. 2 and FIG. 4  
25 disclose this process in steps 210-212 in FIG. 2 and in steps 410-412 in FIG. 4, as  
26 indicated below:

27  
28

1  
2  
3  
4  
5  
6  
7  
8  
9  
10  
11  
12  
13  
14  
15  
16  
17  
18  
19  
20  
21  
22  
23  
24  
25  
26  
27  
28

**FIG. 2**  
CORDLESS TO CELL PHONE HAND OVER

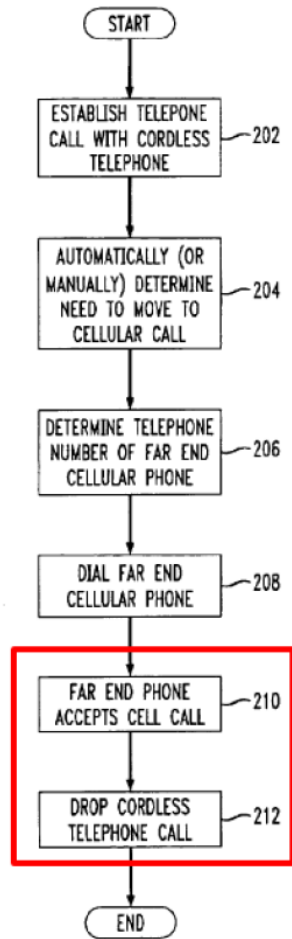

**FIG. 4**  
WALKIE-TALKIE TO CELL PHONE HAND OVER

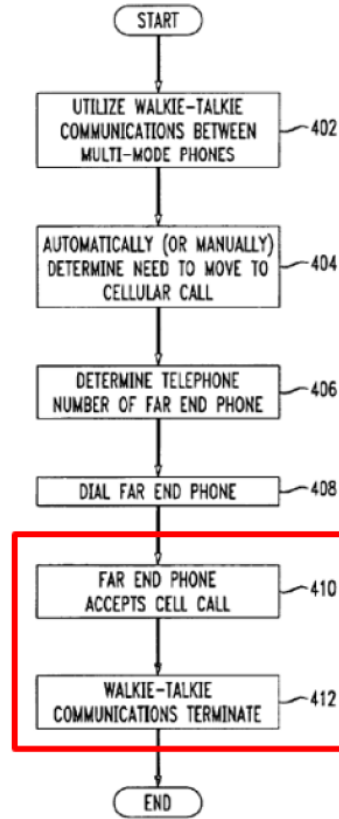

Although steps 210 and 410 indicate an action by the far end phone (“far end phone accepts cell call”), the function performed by the claimed multimode phone as part of these steps is detecting that the far end phone has accepted the call over the second communication path. Ex. K (Wells Op. Decl.) at ¶ 107; ’156 at 5:1-7 (“the old communication path (in this case the cordless telephone call) is dropped, perhaps after a desirable delay [following acceptance of the new call by the far end telephone]”), 5:57-62 (“notify the handset that the new communication path has been established and accepted, allowing the base unit 110 to finally switch the audio

1 path from the cell phone link to the BLUETOOTH™ cordless telephone link and  
2 then disconnect the cell phone call”), 6:18-24, 6:36-40 (“[t]he near end phone, as in  
3 the first example, is then notified that the second call has gone through, allowing the  
4 conversation to continue on a switched over communication path”), 7:17-26 (“after  
5 the cell phone call has been established and accepted by the far end party,  
6 switchover to the cell phone call can be accomplished”).

7 The steps associated with automatic switch over are described at 5:1-7 (steps  
8 210-212) and 7:17-26 (steps 410-412). Accordingly, the corresponding structure for  
9 this limitation is: Fig. 1 (element 101); Fig. 2 steps 210-212; Fig. 4 steps 410-412;  
10 5:1-7; 7:17-26, and claim 1 (“an automatic switch over module, in communication  
11 with both said cell phone functionality and said RF communication functionality”).

12 BNR’s proposed alternative corresponding structure comprises the same vast  
13 swath of the specification as for the preceding term (*i.e.*, over four columns of the  
14 specification; and over 40 paragraphs of text). BNR’s proposed structure includes  
15 numerous components outside of the multimode cell phone (the “Cellular Network,”  
16 a far end phone, and other components depicted in FIGS. 1 and 3), and leaves the  
17 Court and the parties guessing as to whether any accused product contains structure  
18 equivalent to the patent’s lengthy discussion. *Tomita*, 681 F. App’x at 970. BNR’s  
19 proposal should be rejected.

## 20 **VII. U.S. PATENT NO. 7,039,435**

### 21 **A. Technology Background**

22 The ’435 patent is directed to “[a] proximity regulation system for use with a  
23 portable cell phone.” ’435 (Doc. No. 33-9) at Abstract. The specification discloses  
24 that the “invention is directed, in general, to a mobile telecommunications device  
25 and, more specifically, to a system and method of determining a proximity transmit  
26 power level of a portable cell phone based on a proximity to a user.” ’435 at 1:7-10.  
27  
28

1           **B. “position to a communications tower”**

2

Defendants’ Construction	BNR’s Construction
<p>3 Plain and ordinary meaning, no 4 construction necessary.</p> <p>5 In the alternative, to the extent the Court 6 requires a construction for this term, 7 “position to a communications tower” 8 means “position of the portable cell 9 phone relative to a communications tower”</p>	<p>“transmit signal strength of a communications path between the communications tower and the portable cell phone”</p>

10           The term “position to a communications tower” does not require construction  
11 and should be given its plain and ordinary meaning. All sub-elements of the term,  
12 and especially “position” and “communications tower,” are common everyday  
13 words that members of a jury, much less a person of ordinary skill in the art, would  
14 understand without additional clarification. Neither the application nor the  
15 prosecution history of the ’435 patent supports a special definition otherwise.

16           The purpose of claim construction is “to understand and explain, but not to  
17 change, the scope of the claims.” *Embrex, Inc. v. Serv. Eng’g Corp.*, 216 F.3d 1343,  
18 1347 (Fed. Cir. 2000). Under the analytical approach and evidentiary hierarchy for  
19 claim construction set forth by the Federal Circuit in *Phillips*, “[t]he words of a  
20 claim are generally given their ordinary and customary meaning,” which is “the  
21 meaning that the term would have to a person of ordinary skill in the art at the time  
22 of the invention.” *Phillips*, 415 F.3d at 1312-13.

23           Federal Circuit precedent also establishes “only two exceptions to this general  
24 rule: 1) when a patentee sets out a definition and acts as his own lexicographer, or 2)  
25 when the patentee disavows the full scope of a claim term either in the specification  
26 or during prosecution.” *Thorner*, 669 F.3d at 1365. “The standards for finding  
27 lexicography and disavowal are exacting.” *Id.* “To act as its own lexicographer, a  
28

1 patentee must clearly set forth a definition of the disputed claim term other than its  
2 plain and ordinary meaning,” and must “clearly express an intent to redefine the  
3 term.” *Id.* at 1365-66. “The standard for disavowal of claim scope is similarly  
4 exacting,” and requires “expressions of manifest exclusion or restriction,  
5 representing a clear disavowal of claim scope.” *Id.* at 1366. Thus, a “patentee is  
6 free to choose a broad term and expect to obtain the full scope of its plain and  
7 ordinary meaning unless the patentee *explicitly* redefines the term or disavows its  
8 full scope.” *Id.* at 1367. *See also GE Lighting Solutions*, 750 F.3d at 1309 (“[T]he  
9 specification and prosecution history only compel departure from plain meaning in  
10 two instances: lexicography and disavowal.”). Neither lexicography nor disavowal  
11 is present here.

12 To the extent the Court requires a construction for this term, this term should  
13 be construed to mean “position of the portable cell phone relative to a  
14 communications tower” as proposed by Defendants. To provide context, the claim  
15 limitation at issue recites:

16 a power circuit that provides a network adjusted transmit power level  
17 as a function of a position to a communications tower

18 ¶435 at 8:3-5. Thus, the full limitation that includes the term “position to a  
19 communications tower” explains that “a network adjusted transmit power level” is  
20 provided to “a power circuit” as a function of the “position to a communications  
21 tower.”

22 Defendants’ proposed construction is supported by the specification, which  
23 recites “position” or a related variant nine times. A first recitation repeats the claim  
24 language in full. ¶435 at 2:18-21. A second recitation explains that “[t]he  
25 communications tower **110** is a conventional communications tower that is  
26 positioned to communicate with the portable cell phone **120**.” ¶435 at 3:4-6  
27  
28

1 (emphasis in original). This simple relationship, of the cell phone positioned  
2 relative to the communication tower, is shown in '435 Fig. 1:

3 *FIG. 1*

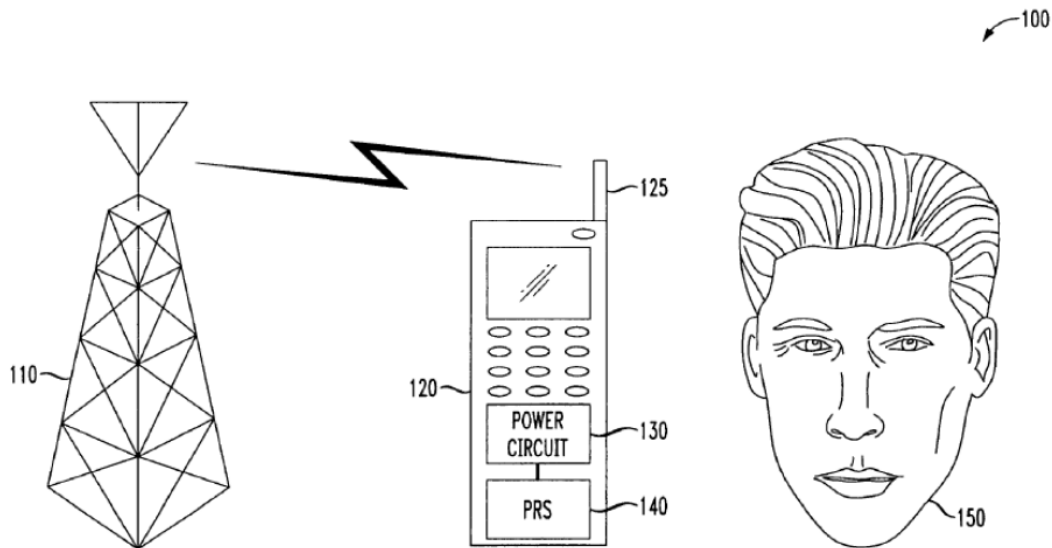

15 The remaining recitations of “position” relate to a “position indicator 290” “to  
16 indicate to the location sensing subsystem 220 that the portable cell phone 200 is  
17 positioned in the belt clip 280.” '435 at 4:26-28, 6:33-40 (emphasis in original).  
18 These recitations also have to do with the position of a cell phone, relative to  
19 another object, a belt clip.  
20

21 None of the recitations of “position” or a related variant in the specification  
22 provide a particular definition or differ from a plain and ordinary meaning of the  
23 term.

24 Applicant also did not make any statements during the prosecution of the '435  
25 patent, that narrowed the meaning of this term from its plain and ordinary meaning.

26 Therefore, to the extent the Court requires a construction for the term  
27 “position to a communications tower,” the correct construction is “position of the  
28 portable cell phone relative to a communications tower.”

1 In contrast, BNR's construction 1) overly complicates simple words; 2) is  
2 not supported by the intrinsic evidence; and 3) is unwieldy when read in context of  
3 the entire claim limitation. BNR proposes the construction "transmit signal  
4 strength of a communications path between the communications tower and the  
5 portable cell phone." As discussed above, the words of the term are simple and  
6 have existing plain and ordinary meanings that have not been altered by the  
7 specification nor disavowed during prosecution. Perhaps most conspicuously,  
8 neither the specification nor the prosecution history describes "a transmit signal  
9 strength of a communication path." Further, under BNR's construction the clause  
10 would read in full:

11 a power circuit that provides a network adjusted transmit power level as  
12 a function of [a transmit signal strength of a communications path  
13 between the communications tower and the portable cell phone]

14 (BNR's proposed construction in brackets). Rather than clarifying the claim, BNR  
15 has introduced at least two new terms that are not defined in the specification or  
16 prosecution history: "transmit signal strength" and "communications path." These  
17 terms are merely recited once and thrice in the specification, respectively, without  
18 further explanation ('435 at 3:39-40, 7:21-25, 7:35-39) and there is no justification  
19 for re-drafting the claims to force a new meaning for the simple claim language.  
20 *Chef Am., Inc. v. Lamb Weston, Inc.*, 358 F.3d 1371, 1374 (Fed. Cir. 2004) ("in  
21 accord with our settled practice we construe the claim as written, not as the  
22 patentees wish they had written it"). Additionally, BNR's construction conflicts  
23 with a discussion in the textbook incorporated by reference in the '435 patent at  
24 3:9-13 and relied upon by BNR to support their construction. *See* Ex. L (William  
25 C.Y. Lee, *Mobile Communications Engineering: Theory and Applications* (1997))  
26 at 110-11 (referencing Fig. 3.7, relative to the incident wave  $E$  and "[t]he scattered  
27 field  $E_s$ , arriving at point  $P$ ," stating " $d_0$  is the direct-path distance between the  
28 base-station antenna and the mobile receiving antenna and  $d'$  is the distance from



1 the base-station antenna to the scattering point Q. . . . Point *P* can be assumed as  
2 the position of the mobile unit.”). Thus, the position is not “a transmit signal  
3 strength of a communication path . . .” and should not be construed as such.

4 Accordingly, Defendants respectfully submit that the term “position to a  
5 communications tower” does not require construction. To the extent the court  
6 deems that construction is needed, the term should be construed according to its  
7 plain and ordinary meaning of “position of the portable cell phone relative to a  
8 communications tower.”

9 **VIII. CONCLUSION**

10 Based on the foregoing, Defendants respectfully request the Court adopt  
11 Defendants’ proposed constructions.

12  
13  
14  
15  
16  
17  
18  
19  
20  
21  
22  
23  
24  
25  
26  
27  
28

1 Dated: May 24, 2019

FISH & RICHARDSON P.C.

2 By: *s/ Joanna M. Fuller*

3 Jason W. Wolff (SBN 215819)

wolff@fr.com

4 Joanna M. Fuller (SBN 266406)

5 jfuller@fr.com

FISH & RICHARDSON P.C.

6 12390 El Camino Real

7 San Diego, CA 92130

8 Phone: (858) 678-5070 / Fax: (858) 678-5099

9 Michael Sobolev (SBN 285184) sobolev@fr.com

FISH & RICHARDSON P.C.

10 500 Arguello Street, Suite 500

11 Redwood City, CA 94063

12 Phone: (650) 839-5070 / Fax: (650) 839-5071

13 Ethan J. Rubin, appearing *pro hac vice*

14 (MA SBN696375), erubin@fr.com

FISH & RICHARDSON P.C.

15 One Marina Park Drive

16 Boston, MA 02210-1878

17 Phone: (617) 542-5070 / Fax: (617) 542-8906

18 Attorneys for Defendants

19 HUAWEI DEVICE (DONGGUAN) CO., LTD.,

20 HUAWEI DEVICE (SHENZHEN) CO., LTD., and

21 HUAWEI DEVICE USA, INC.

1 Dated: May 24, 2019

PERKINS COIE LLP

2 By: *s/James Young Hurt*

3 John P. Schnurer, jschnurer@perkinscoie.com

4 Joseph P. Reid, jreid@perkinscoie.com

5 Thomas N. Millikan, tmillikan@perkinscoie.com

6 Yun (Louise) Lu, llu@perkinscoie.com

7 James Young Hurt, jhurt@perkinscoie.com

PERKINS COIE LLP

11452 El Camino Real, Suite 300

San Diego, CA 92130

Phone: (858) 720-5700 / Fax: (848) 720-5799

9  
10 Attorneys for Defendants,

11 COOLPAD TECHNOLOGIES, INC., AND

12 YULONG COMPUTER COMMUNICATIONS

13 Joining Sections I-III, VI, and VIII.

14

15

16

17

18

19

20

21

22

23

24

25

26

27

28

1  
2  
3  
4  
5  
6  
7  
8  
9  
10  
11  
12  
13  
14  
15  
16  
17  
18  
19  
20  
21  
22  
23  
24  
25  
26  
27  
28

Dated: May 24, 2019

JONES DAY

By: *s/ Thomas W. Ritchie*

---

M. Andrew Woodmansee,  
mawoodmansee@jonesday.com  
Douglas L. Clark, dlclark@jonesday.com  
JONES DAY  
4655 Executive Drive, Suite 1500  
San Diego, CA 92121-3134  
Phone: (858) 314-1200 / Fax: (844) 345-3178

David L. Witcoff, dlwitcoff@jonesday.com  
Marc S. Blackman, msblackman@jonesday.com  
Thomas W. Ritchie, twritchie@jonesday.com  
JONES DAY  
77 West Wacker  
Chicago, IL 60601-1692  
Phone: (312) 782-3939 / Fax: (312) 782-8585

Attorneys for Defendants, KYOCERA  
CORPORATION and KYOCERA  
INTERNATIONAL, INC.,

1 Dated: May 24, 2019

2 By: *s/ Amol A. Parikh*

3 Timothy A. Horton,  
4 timhorton@timhortonlaw.com  
5 LAW OFFICE OF TIMOTHY A. HORTON  
6 600 West Broadway, Suite 700  
7 San Diego, CA 92101  
8 Phone: (619) 272-7017 / Fax: (619) 374-1668

9 Charlie McMahon, cmcmahon@mwe.com  
10 Brian A. Jones, bajones@mwe.com  
11 Amol A. Parikh, amparikh@mwe.com  
12 MCDERMOTT WILL & EMERY LLP  
13 444 West Lake Street  
14 Chicago, IL 60606-0029  
15 Phone: (312) 372-2000 / Fax: (312) 984-7700

16 Jiaxiao Zhang, jiazhang@mwe.com  
17 McDERMOTT WILL & EMERY LLP  
18 18565 Jamboree Road, Suite 250  
19 Irvine, CA 92612-2565  
20 Phone: (949) 851-0633 / Fax: (949) 851-9348

21 Attorneys for Defendants ZTE CORPORATION,  
22 ZTE (USA), INC., and ZTE (TX), INC.  
23  
24  
25  
26  
27  
28

1  
2  
3  
4  
5  
6  
7  
8  
9  
10  
11  
12  
13  
14  
15  
16  
17  
18  
19  
20  
21  
22  
23  
24  
25  
26  
27  
28

**FILER’S ATTESTATION**

Pursuant to Section 2(f)(2) of the Electronic Case Filing Administrative Policies and Procedures of the United States District Court of the Southern District of California, I certify that authorization for the filing of this document has been obtained from each of the other signatories shown above and that all signatories have authorized placement of their electronic signature on this document.

Dated May 24, 2019.

*s/ Joanna M. Fuller*  
\_\_\_\_\_  
Joanna M. Fuller

1  
2  
3  
4  
5  
6  
7  
8  
9  
10  
11  
12  
13  
14  
15  
16  
17  
18  
19  
20  
21  
22  
23  
24  
25  
26  
27  
28

**CERTIFICATE OF SERVICE**

The undersigned hereby certifies that a true and correct copy of the above and foregoing document has been served on May 24, 2019 to all counsel of record who are deemed to have consented to electronic service via the Court’s CM/ECF system per Civil Local Rule 5.4. Any other counsel of record will be served by electronic mail, facsimile and/or overnight delivery.

Executed on May 24, 2019 at San Diego, California.

*s/ Joanna M. Fuller*  
\_\_\_\_\_  
Joanna M. Fuller