

John P. Schnurer, Bar No. 185725
JSchnurer@perkinscoie.com
Joseph P. Reid, Bar No. 211082
JReid@perkinscoie.com
Thomas N. Millikan, Bar No. 234430
TMillikan@perkinscoie.com
Yun (Louise) Lu, Bar No. 253114
LLu@perkinscoie.com
James Young Hurt, Bar No. 312390
JHurt@perkinscoie.com
PERKINS COIE LLP
11452 El Camino Real, Suite 300
San Diego, California 92130-2080
Telephone: 858.720.5700
Facsimile: 858.720.5799

Attorneys for Defendants Coolpad
Technologies, Inc. and Yulong Computer
Communications and Counterclaim Plaintiff
Coolpad Technologies, Inc.

*[Counsel for co-defendants identified on
signature page]*

**IN THE UNITED STATES DISTRICT COURT
SOUTHERN DISTRICT OF CALIFORNIA**

BELL NORTHERN RESEARCH,
LLC,

Plaintiff,

v.

COOLPAD TECHNOLOGIES, INC.
AND YULONG COMPUTER
COMMUNICATIONS,

Defendants.

C.A. No. 3:18-cv-1783-CAB-BLM (lead
case)

**DEFENDANTS' JOINT INVALIDITY
CONTENTIONS**

Judge: Hon. Cathy Ann Bencivengo

BELL NORTHERN RESEARCH,
LLC,

Plaintiff,

v.

HUAWEI DEVICE (DONGGUAN)
CO., LTD, HUAWEI DEVICE
(SHENZHEN) CO., LTD., and
HUAWEI DEVICE USA, INC.,

C.A. No. 3:18-cv-1784-CAB-BLM

**DEFENDANTS' JOINT INVALIDITY
CONTENTIONS**

Judge: Hon. Cathy Ann Bencivengo

Defendants.

BELL NORTHERN RESEARCH,
LLC,

Plaintiff,

v.

KYOCERA CORPORATION and
KYOCERA INTERNATIONAL INC.,

Defendants.

C.A. No. 3:18-cv-1785-CAB-BLM

**DEFENDANTS' JOINT INVALIDITY
CONTENTIONS**

Judge: Hon. Cathy Ann Bencivengo

BELL NORTHERN RESEARCH,
LLC,

Plaintiff,

v.

ZTE CORPORATION,
ZTE (USA) INC., and
ZTE (TX) INC.,

Defendants.

C.A. No. 3:18-cv-1786-CAB-BLM

**DEFENDANT'S JOINT INVALIDITY
CONTENTIONS**

Judge: Hon. Cathy Ann Bencivengo

Pursuant to S.D. Cal. Patent Local Rules 3.3 and 3.4, and the Rules and Orders of this Court, Defendants Coolpad Technologies, Inc., Yulong Computer Communications, Huawei Device (Dongguan) Co., Ltd., Huawei Device (Shenzhen) Co., Ltd., Huawei Device USA, Inc., Kyocera Corporation, Kyocera International Inc., ZTE Corporation, ZTE (USA) Inc., and ZTE (TX) Inc. (collectively, “Defendants”) hereby serve their Joint Invalidity Contentions (“Invalidity Contentions”) on Plaintiff Bell Northern Research, LLC (“BNR”) in support of their allegations of invalidity of United States Patent Nos. 7,319,889 (“889 Patent”); 8,204,554 (“554 Patent”); 7,990,842 (“842 Patent”); 8,416,862 (“862 Patent”); 7,957,450 (“450 Patent”); 6,941,156 (“156 Patent”); 8,792,432 (“432 Patent”); and 7,039,435 (“435 Patent”) (collectively, the “Asserted Patents”). While all of the claims collectively asserted against the Defendants are addressed below, each Defendant hereby submits these Contentions only with respect to the patents and claims that BNR has asserted against each such Defendant.

I. INTRODUCTION AND RESERVATION OF RIGHTS

These Invalidity Contentions are based on information currently available to Defendants. Defendants’ investigation and analysis of prior art is ongoing, and they reserve the right to supplement or modify these Invalidity Contentions in a manner consistent with the Federal Rules of Civil Procedure and the Court’s rules.

Defendants’ Invalidity Contentions do not constitute an admission that any current, past, or future version of the accused products infringe the Asserted Patents either literally or under the doctrine of equivalents. Unless otherwise stated, Defendants have relied on the broad claim constructions of the asserted claims that BNR has implicitly adopted in its Disclosure of Asserted Claims and Infringement Contentions (“Infringement Contentions”), to the extent any construction can be inferred from BNR’s Infringement Contentions. Such reliance should not be taken to mean that Defendants understand, or are adopting or agreeing with, BNR’s apparent constructions. Defendants expressly do not do so and reserve their right to contest

them.

Defendants' Invalidity Contentions are made in the alternative, and should not be interpreted to reply upon, or in any way affect, the non-infringement arguments Defendants intend to assert in this case.

Although citations are made to exemplary passages in the prior art, Defendants reserve the right to rely upon additional passages that also may be applicable, or that may become applicable in light of any judicially ordered claim construction, changes in Plaintiff's infringement contentions, and/or information obtained during remaining discovery. Where Defendants cite and rely on a U.S. patent, Defendants necessarily cite, rely upon and incorporate by reference as additional prior art each and every foreign priority patent (and the applications for those foreign priority patents) cited in the identified U.S. patent.

In these Invalidity Contentions (in either this cover pleading or in the Invalidity Claim Charts attached as exhibits hereto), reference to "one of ordinary skill," "skilled artisan" or any other similar term refers to a person of ordinary skill in the art at the time of the alleged invention, as laid out in 35 U.S.C. § 103, for whichever particular patent-in-suit is being discussed.

These Invalidity Contentions are based on information currently available to Defendants. Defendants' investigation and analysis is ongoing, and Defendants reserve the right to supplement or modify these Invalidity Contentions in a manner consistent with the Federal Rules of Civil Procedure and the Court's rules. Because Defendants' investigation regarding the invalidity of the asserted patents is not yet complete, certain defenses, including, for example, non-patentable subject matter under 35 U.S.C. §101, knowledge or use by others under 35 U.S.C. § 102(a), public use and/or on-sale bar under 35 U.S.C. § 102(b), derivation or prior inventorship under 35 U.S.C. §§ 102(f)/(g), inequitable conduct, unenforceability, and estoppel, etc. may only become apparent as additional information becomes available. For example, Defendants continue to investigate technological systems. More generally, some of the

prior art items identified in these Invalidity Contentions relate to systems and products. Defendants are investigating these prior art systems and products, and their associated product literature and web pages, and reserve the right to modify, amend and/or supplement these contentions as information becomes available during discovery. Defendants have not yet had the opportunity to conduct sufficient fact discovery regarding their unenforceability defenses. To the extent that during discovery any evidence is produced that supports a contention that the '889, '554, '842, '862, '450, '156, '432, and/or '435 patents are unenforceable due to inequitable conduct during prosecution of the '889, '554, '842, '862, '450, '156, '432, and/or '435 patents or for any other reason, Defendants reserve all rights to amend and/or supplement their Invalidity Contentions to include such unenforceability contentions.

In particular, and without limitation, Defendants reserve the right to identify other art or to supplement their disclosures or contentions for at least the following reasons:

(i) Defendants' position on the invalidity of particular claims will depend on any claim construction from the Court, any findings as to the priority date of the asserted claims, any findings as to the level of skill attributable to a person of ordinary skill in the art, and/or positions that BNR or expert witness(es) may take concerning claim construction, infringement, and/or invalidity.

(ii) Defendants' search for prior art is ongoing, and they may discover and/or analyze additional art, and additional materials relating to the art cited herein.

(iii) Defendants have not yet completed discovery from Plaintiff. Depositions of the persons involved in the drafting and prosecution of the asserted patents, and of the named inventors, for instance, will likely reveal information that affects the disclosures and contentions herein.

(iv) Defendants have not yet completed discovery from third parties who have information concerning the prior art cited herein, and possibly additional art. Such discovery may also reveal information that affects the disclosures and contentions

herein.

(v) If BNR modifies any assertion or contention in its Infringement Contentions, or presents any new assertion or contention relevant to these Invalidity Contentions, Defendants reserve the right to supplement or otherwise amend these Invalidity Contentions.

Defendants' claim charts cite to particular teachings and disclosures of the prior art as applied to features of the asserted claims. However, persons having ordinary skill in the art generally view an item of prior art in the context of other publications, literature, products, and their own experience and understanding. As such, the cited portions in Defendants' claim charts are exemplary only. Where Defendants cite to a particular figure in a reference, the citation should be understood to encompass the caption and description of the figure and any text relating to the figure. Similarly, where Defendants cite to particular text referring to a figure, the citation should be understood to include the figure and caption as well. Furthermore, Defendants reserve the right to rely on uncited portions of the prior art references and on other publications and expert testimony as aids in understanding and interpreting the cited portions, as providing context thereto, as additional evidence that the prior art discloses a claim limitation or the invention as a whole, as evidence of the state of the art at a particular time, and/or as evidence of the obviousness factor of contemporaneous development by others. Defendants further reserve the right to rely on uncited portions of the prior art references, other publications, and testimony, including expert testimony, to establish bases for combination of prior art references that render the asserted claims obvious.

The references discussed in the claim charts may disclose the elements of the asserted claims explicitly and/or inherently, and/or they may be relied upon to show the state of the art in the relevant time frame. Obviousness combinations are provided in the alternative to Defendants' anticipation contentions and are not to be construed to suggest that any reference included in any combination is not by itself anticipatory.

Prior art patents or publications included in these Contentions may be related (*e.g.*, as a divisional, continuation, continuation-in-part, parent, child, or other relation or claim of priority) to earlier or later filed patents or publications, may have counterparts filed in other jurisdictions, or may incorporate (or be incorporated by) other patents or publications by reference. The listed patents or publications are intended to be representative of these other patents or publications, to the extent they exist. On information and belief, each listed publication or invention became prior art at least as early as the dates given.

Moreover, as certain prior art systems and inventions are described in multiple related patents or publications with similar or identical specifications or disclosures, to the extent Defendants have identified a citation in one reference, Defendants reserve the right to rely on parallel or similar citations in related patents or publications. Persons of ordinary skill in the art would read a prior art reference and understand prior art inventions as a whole and in the context of other publications, literature, and technologies. Therefore, to understand and interpret any specific statement or disclosure of a potential prior art reference or invention, such persons would rely on other information within the reference or invention, along with other publications and their general scientific knowledge.

Defendants also incorporate, in full, all prior art references cited in the Asserted Patents, all references incorporated by reference into those references, and the Asserted Patents' prosecution history.

In addition to the prior art identified below and in the accompanying invalidity claim charts, Defendants incorporate by reference any additional invalidity contentions, identified prior art, or invalidity claim charts disclosed at any date by any party to any litigation or U.S. Patent & Trademark Office proceeding involving the asserted patent or any related patent, including, without limitation, any parties' invalidity contentions (including all amendments/supplementations), and expert reports (including all amendments/supplementations), and any references identified in any

1 reexamination request or proceeding relating to any of the Asserted Patents.
2 Defendants may further rely on any prior art references or documents relating to the
3 validity of the asserted patents, ever known or identified by or to Plaintiff, the named
4 inventors of the asserted patents, assignees of the asserted patents, or any person
5 substantively involved in the prosecution of the asserted patents, including any prior
6 art references produced in the bates range BNR-SDCA00016026 – BNR-
7 SDCA00033398.

8 **II. IDENTIFICATION OF PRIOR ART**

9 Pursuant to Patent L.R. 3.3, and subject to Defendants’ reservation of rights,
10 Defendants identify at least the following prior art now known to Defendants to
11 anticipate and/or render obvious the asserted claims of the ’889 Patent, ’554 Patent,
12 ’842 Patent, ’862 Patent, ’450 Patent, ’156 Patent, ’432 Patent, and ’435 Patent. As
13 explained in their reservation of rights, Defendants have, in certain instances, applied
14 the prior art in accordance with BNR’s improper assertions of infringement and
15 improper application of the asserted claims. Defendants do not agree with BNR’s
16 application, however, and deny infringement.

17 The below-identified references presently known to Defendants anticipate
18 and/or render obvious one or more of the asserted claims of the ’889 Patent, ’554
19 Patent, ’842 Patent, ’862 Patent, ’450 Patent, ’156 Patent, ’432 Patent, and ’435 Patent.

20 **A. Prior Art References for the ’889 Patent**

21 Pursuant to Patent L.R. 3.3, the tables below identify the prior art items that
22 Defendants presently assert anticipate and/or render obvious the asserted claims of the
23 ’889 Patent. Where applicable, this includes information about any alleged knowledge
24 of use of the invention in this country prior to the date of invention of the ’889 Patent.

U.S. Patents or Patent Publications	Date of Publication or Issue
1. U.S. Patent No. 5,010,566 (“Seo”)	April 23, 1991

2. U.S. Patent No. 5,586,182 (“Miyashita”)	December 17, 1996
3. U.S. Patent Application Publication No. 2004/0225904 (“Perez”)	November 11, 2004 (filed May 6, 2003)

Other Printed Publications	Date of Publication
4. Japanese Unexamined Patent Application Publication No. 2000-106598 (“Fukiharu ’598”)	April 11, 2000
5. Japanese Unexamined Patent Application Publication No. H11-220432 (“Numazawa”)	August 10, 1999
6. World Intellectual Property Organization Publication No. WO 00/78012 (“Sparre”)	December 21, 2000
7. U.K. Patent Application No. 2,357,400 (“Mantjarvi”)	June 20, 2001

In addition to the above prior art references, Defendants identify the following patents, printed publications, product literature, and other materials that are pertinent to invalidity of the asserted claims. Defendants may rely on these references as invalidating prior art, evidence of the knowledge of those skilled in the art, and/or evidence to support a motivation to combine or modify other prior art. Defendants reserve all rights to supplement or modify these invalidity contentions and to rely on these references to prove invalidity of the asserted claims in a manner consistent with the Federal Rules of Civil Procedure and the Rules of this Court.

Additional Prior Art References	Date of Issue or Publication
8. U.S. Patent No. 5,881,377 (“Giel”)	March 9, 1999
9. U.S. Patent No. 5,729,604 (“Van Schyndel”)	March 17, 1998
10. U.S. Patent No. 6,631,192 (“Fukiharu 192”)	October 7, 2003 (filed September 22, 1999)

11.U.S. Patent No. 6,801,794 (“Bauer”)	September 27, 2001
12.U.S. Patent Application Publication No. 2004/0029546 (“Tsuchi 546”)	February 12, 2004 (filed June 1, 2001)
13.U.S. Patent Application Publication No. 2005/0057548 (“Kim”)	March 17, 2005
14.World Intellectual Property Organization Publication No. WO 00/195596 (“Tsuchi 596”)	December 13, 2001
15.U.K. Patent Application No. 2256772 (“So”)	December 16, 1992
16.S. Segars, “The ARM9 family-high performance microprocessors for embedded applications”, Proc. ICCD, pp. 230-235, 1998-Oct.	October 1998
17.Japanese Unexamined Patent Application Publication 2001-230859	August 24, 2001 (filed February 18, 2000)
18.U.S. Patent No. 6,314,303 (“Phipps”)	November 6, 2001 (filed July 29, 1997)
19.European Patent Application No. 1,058,465 (“Farah”)	December 6, 2000
20.U.K. Patent Application No. 2,275,848 (“Champness”)	September 7, 1994
21.U.S. Patent No. 5,239,673 (“Natarajan”)	August 24, 1993
22.U.S. Patent No. 5,297,191 (“Gerszberg”)	March 22, 1994
23.U.S. Patent No. 5,479,484 (“Mukerjee”)	December 26, 1995

B. Prior Art References for the ’554 Patent

Pursuant to Patent L.R. 3.3, the tables below identify the prior art items that Defendants presently assert anticipate and/or render obvious the asserted claims of the ’554 Patent. Where applicable, this includes information about any alleged knowledge of use of the invention in this country prior to the date of invention of the ’554 Patent.

U.S. Patents or Patent Publications	Date of Issue or Publication
24.U.S. Patent No. 5,010,566 (“Seo”)	April 23, 1991
25.U.S. Patent No. 5,586,182 (“Miyashita”)	December 17, 1996
26.U.S. Patent Application Publication No. 2004/0225904 (“Perez”)	November 11, 2004 (filed May 6, 2003)

Other Printed Publications	Date of Publication
27.Japanese Unexamined Patent Application Publication No. 2000-106598 (“Fukiharu ’598”)	April 11, 2000
28.Japanese Unexamined Patent Application Publication No. H11-220432 (“Numazawa”)	August 10, 1999
29.World Intellectual Property Organization Publication No. WO 00/78012 (“Sparre”)	December 21, 2000
30.U.K. Patent Application No. 2,357,400 (“Mantjarvi”)	June 20, 2001

Additional Prior Art References	Date of Issue or Publication
31.U.S. Patent No. 5,881,377 (“Giel”)	March 9, 1999
32. U.S. Patent No. 5,729,604 (“Van Schyndel”)	March 17, 1998
33.U.S. Patent No. 6,631,192 (“Fukiharu 192”)	October 7, 2003 (filed September 22, 1999)
34.U.S. Patent No. 6,801,794 (“Bauer”)	September 27, 2001
35.U.S. Patent Application Publication No. 2004/0029546 (“Tsuchi 546”)	February 12, 2004 (filed June 1, 2001)
36.U.S. Patent Application Publication No. 2005/0057548 (“Kim”)	March 17, 2005
37.World Intellectual Property Organization Publication No. WO 00/195596 (“Tsuchi 596”)	December 13, 2001
38.U.K. Patent Application No. 2256772 (“So”)	December 16, 1992

39.S. Segars, "The ARM9 family-high performance microprocessors for embedded applications", Proc. ICCD, pp. 230-235, 1998-Oct.	October 1998
40.Japanese Unexamined Patent Application Publication 2001-230859	August 24, 2001 (filed February 18, 2000)
41.U.S. Patent No. 6,314,303 ("Phipps")	November 6, 2001 (filed July 29, 1997)
42.European Patent Application No. 1,058,465 ("Farah")	December 6, 2000
43.U.K. Patent Application No. 2,275,848 ("Champness")	September 7, 1994
44.U.S. Patent No. 5,239,673 ("Natarajan")	August 24, 1993
45.U.S. Patent No. 5,297,191 ("Gerszberg")	March 22, 1994
46.U.S. Patent No. 5,479,484 ("Mukerjee")	December 26, 1995

C. Prior Art References for the '842 Patent

Pursuant to Patent L.R. 3.3, the tables below identify the prior art items that Defendants presently assert anticipate and/or render obvious the asserted claims of the '842 Patent. Where applicable, this includes information about any alleged knowledge of use of the invention in this country prior to the date of invention of the '842 Patent.

U.S. Patents or Patent Publications		Date of Issue or Publication
47.	U.S. Patent No. 7,318,185 ("Khandani")	January 8, 2008 (filed on December 9, 2002)
48.	U.S. Patent Publication 2006/0002361 ("Webster")	January 5, 2006 (filed on July 21, 2005 and claims priority to provisional

		applications filed on June 22, 2004 and July 21, 2004)
49.	U.S. Patent No. 7,453,793 (“Jones”)	November 18, 2008 (filed on April 12, 2004 and claims priority to a provisional application filed on April 10, 2003)
50.	U.S. Patent No. 7,742,388 (“Shearer”)	June 22, 2010 (filed on July 20, 2005 and claims priority to a provisional application filed on July 20, 2004)
51.	U.S. Patent Publication 2007/0060073 (“Boer”)	March 15, 2007 (PCT filed on June 30, 2004 and claims priority to a provisional application filed on June 30, 2003)

Other Printed Publications		Date of Publication
52.	IEEE Std. 802.11a-1999 Supplement to IEEE Std. 802.11-1999 (“IEEE 802.11a-1999)	December 30, 1999
53.	A MIMO-OFDM System for High-Speed Transmission (“Ogawa”)	October 9, 2003

In addition to the above prior art references, Defendants identify the following

1 patents, printed publications, product literature, and other materials that are pertinent to
2 invalidity of the asserted claims. Defendants may rely on these references as
3 invalidating prior art, evidence of the knowledge of those skilled in the art, and/or
4 evidence to support a motivation to combine or modify other prior art. Defendants
5 reserve all rights to supplement or modify these invalidity contentions and to rely on
6 these references to prove invalidity of the asserted claims in a manner consistent with
7 the Federal Rules of Civil Procedure and the Rules of this Court.

Additional Prior Art References	Date of Issue or Publication
54. U.S. Patent Publication 2005/0233709 (“Gardner”)	October 20, 2005 (filed on April 5, 2004 and claims priority to a provisional application filed on April 10, 2003)
55. International Application Publication No. WO 2004/030265 A1 (“Sandell”)	April 8, 2004 (international filing date of September 25, 2003 claiming priority to Great Britain Application GB20020022410 filed on September 26, 2002)
56. U.S. Patent No. 5,479,444 (“Malkamaki”)	December 26, 1995
57. U.S. Patent No. 6,438,173 (“Stantchev”)	August 20, 2002
58. U.S. Patent No. 7,324,605 (“Maltsev I”)	January 29, 2008 (filed on March 26, 2004 and

	claims priority to a provisional application filed on January 12, 2004)
59. U.S. Patent No. 7,349,436 (“Maltsev II”)	March 25, 2008 (filed on September 30, 2003)
60. U.S. Patent No. 7,433,418 (“Dogan”)	October 7, 2008 (filed on September 28, 2001)
61. U.S. Patent No. 7,444,134 (“Hansen”)	October 28, 2008 (filed on February 14, 2005 and claims priority to provisional applications filed on June 17, 2004, May 7, 2004, February 19, 2004, and February 13, 2004)
62. U.S. Patent Publication No. 2003/0043887 A1 (“Hudson”)	March 6, 2003 (filed on March 29, 2002 and is a continuation in part of an application filed on April 3, 2001)
63. U.S. Patent No. 7,599,332 (“van Zelst”)	October 6, 2009 (filed on May 27, 2005 and is a continuation in part to an application filed on April 5, 2004)

		that claims priority to a provisional application filed on May 27, 2004)
64.	U.S. Patent No. 7,392,015 (“Farlow”)	June 24, 2008 (filed on January 7, 2004 and claims priority to a provisional application filed on February 14, 2003)
65.	U.S. Patent No. 5,914,933 (“Cimini”)	June 22, 1999
66.	Frequency Scaled Time Domain Equalization for OFDM in Broadband Fixed Wireless Access Channels (“Abhayawardhana”)	March 21, 2002
67.	Modifications to OFDM FFT-256 mode for supporting mobile operation (“Liebetreu”)	March 3, 2003

D. Prior Art References for the '862 Patent

Pursuant to Patent L.R. 3.3, the tables below identify the prior art items that Defendants presently assert anticipate and/or render obvious the asserted claims of the '862 Patent. Where applicable, this includes information about any alleged knowledge of use of the invention in this country prior to the date of invention of the '862 Patent.

U.S. Patents or Patent Publications	Date of Issue or Publication
68. U.S. Patent Pub. No. 2006/0068718 (“Li 718”)	Mar. 30, 2006
69. U.S. Patent No. 7,710,925 (“Poon 925”)	May 4, 2010
70. U.S. Patent No. 7,570,696 (“Maltsev 696”)	Aug. 4, 2009
71. U.S. Patent No. 7,236,748 (“Li 748”)	June 26, 2007
72. U.S. Patent No. 7,492,829 (“Lin 829”)	Feb. 17, 2009
73. U.S. Patent No. 7,280,625 (“Ketchum 625”)	Oct. 9, 2007

Other Printed Publications	Date of Publication
-----------------------------------	----------------------------

74. June Chul Roh and Bhaskar D. Rao, <i>An Efficient Feedback Method for MIMO Systems with Slowly Time-Varying Channels</i> , Roh and Rao, 2004 IEEE Wireless Communications and Networking Conference (IEEE Cat. No.04TH8733) (“Roh”).	Mar. 2004
75. B. Yang and J. F. Bohme, <i>Reducing The Computations Of The Singular Value Decomposition Array Given By Brent And Luk</i> , Vol. 12, No. 4, SIAM J. Matrix Anal. Appl., 713-725 (“Yang”)	Oct. 1991

In addition to the above prior art references, Defendants identify the following patents, printed publications, product literature, and other materials that are pertinent to invalidity of the asserted claims. Defendants may rely on these references as invalidating prior art, evidence of the knowledge of those skilled in the art, and/or evidence to support a motivation to combine or modify other prior art. Defendants reserve all rights to supplement or modify these invalidity contentions and to rely on these references to prove invalidity of the asserted claims in a manner consistent with the Federal Rules of Civil Procedure and the Rules of this Court.

Additional Prior Art References	Date of Issue or Publication
76.U.S. Patent No. 7,450,532 (“Chae”)	Nov. 11, 2008
77.US. Patent No. 6,058,105 (“Hochwald”)	May 2, 2000
78.U.S. Patent No. 6,144,711 (“Raleigh”)	Nov. 7, 2000
79.U.S. Patent No. 6,859,503	Feb. 22, 2005
80.U.S. Patent No. 8,619,907	Dec. 31, 2013
81.U.S. Patent No. 7,742,546 (“Ketchum 546”)	June 22, 2010
82.U.S. Patent Pub. No. 2005/0063378	Mar. 24, 2005
83.U.S. Patent Pub. No. 2005/0078762 (“Ketchum 762”)	Apr. 14, 2005
84.U.S. Patent Pub. No. 2006/0105767	May 18, 2006
85.U.S. Patent Pub. No. 2008/0170533	July 17, 2008
86.U.S. Patent Pub. No. 2004/0165684 (“Ketchum 684”)	Aug. 26, 2004
87.WO 2004/038984 (“Walton 984”)	May 6, 2004
88.WO 2004/086712 (“Walton 712”)	Oct. 7, 2004
89.GILBERT STRANG, LINEAR ALGEBRA AND ITS APPLICATIONS, 2nd ed., Academic Press	1980

90. IEEE 802.11a-1999 - IEEE Standard for Telecommunications and Information Exchange Between Systems - LAN/MAN Specific Requirements - Part 11: Wireless Medium Access Control (MAC) and physical layer (PHY) specifications: High Speed Physical Layer in the 5 GHz band	1999
91. Cavallaro et al., "A CORDIC Processor Array for the SVD of a Complex Matrix," SVD and Signal Processing, II, Algorithms, Analysis and Applications, Elsevier Science Publishers	1991
92. Dickson et al., "QRD and SVD Processor Design Based on a Approximate Rotations Algorithm," IEEE Workshop on Signal Processing Systems (SIPS 2004).	Oct. 13, 2004
93. Liu et al., "CORDIC Based Application Specific Instruction Set Processor for QRD/SVD," The Thirty-Seventh Asilomar Conference on Signals, Systems & Computers	Nov. 9, 2003
94. M. Rim, "Multi-User Downlink Beamforming with Multiple Transmit and Receive Antennas," Electronic Letters, Vol. 38, No. 25.	Dec. 5, 2002
95. Mehdi Ansari Sadrabadi et al., A New Method of Channel Feedback Quantization for High Data Rate MIMO Systems, IEEE	2004
96. Speiser et al., "Signal Processing Computations Using the Generalized Singular Value Decomposition"	Oct. 1984
97. Vanpoucke et al., "Numerically Stable Jacobi Array for Parallel Singular Value Decomposition (SVD) Updating," Proceedings of the SPIE 2296, Advanced Signal Processing: Algorithms, Architectures, and Implementations V	Oct. 28, 1994
98. Windpassinger, "Detection and Precoding for Multiple Input Multiple Output Channels"	2004
99. Sadrabadi et al., "A New Method of Channel Feedback Quantization for High Data Rate MIMO Systems," IEEE Global Telecommunications Conference (GLOBECOM '04),	Nov. 29, 2004.
100. Boyd Bangerter, et al., High-Throughput Wireless LAN Air Interface, Intel Technology Journal	Aug. 2003
101. André Bourdoux, et al. Preambles for MIMO channel estimation (r1), IMEC, Wireless Research	July 2004
102. Enhance the Beamforming Feature of the Multiple Antenna Tx Diversity, TSG-RAN Working Group 1 meeting No. 15, TSGR1#15(00)-1065	Aug. 22, 2000
103. Dhananjay A. Gore, Selecting an Optimal Set of Transmit	2000

Antennas for a Low Rank Matrix Channel, IEEE	
104. Christopher J. Hansen, Preambles, Beamforming, and the WWiSE Proposal (r1), IEEE	Jan. 17, 2005
105. Yingbo Hua, et al., Optimal Reduced-Rank Estimation and Filtering, IEEE	Mar. 2001
106. Taehyun Jeon, et al., Adaptive Modulation for MIMO-OFDM Systems, IEEE	Mar. 2004
107. John Ketchum, et al., PHY Design for Spatial Multiplexing MIMO WLAN, IEEE	Jul. 2004
108. John Ketchum, et al., System Description and Operating Principles for High Throughput Enhancements to 802.11, IEEE	Aug. 2004
109. John Ketchum, et al., 802.11 TGn High Throughput Proposal Compliance Statement, IEEE	Aug. 2004
110. Syed Aon Mujtaba, TGn Sync Proposal Technical Specification, IEEE	Aug. 2004
111. Daniel Nassani (Nissensohn), A Novel MIMO Transmission Method proposed herein as 802.11 TGn PHYSical Layer Element	Nov. 2003
112. Gregory G. Raleigh, et al., Spatio-Temporal Coding for Wireless Communication, IEEE	Mar. 1998
113. John S. Sadowsky, et al., WWiSE Preambles and MIMO Beamforming? (r1)	Jan. 15, 2005
114. Hemanth Sampath, Linear Precoding and Decoding for Multiple Input Multiple Output (MIMO) Wireless Channels, A Dissertation Submitted To the Dept. Of Electrical Engineering, Stanford University	Apr. 2001
115. Hilde Skjevling, Simulation and design of MIMO algorithms for correlated wireless channels, University of Oslo, Dept. of Informatics	Jul. 25, 2003
116. Gordon L Stüber, et al., Broadband MIMO-OFDM Wireless Communications, IEEE	Feb. 2004
117. Christopher J. Hansen, et al., Preambles, Beamforming, and the WWiSE Proposal, IEEE 802.11-05/1645r2	Jan. 17, 2005
118. M.P.Fitton, et al., Reconfigurable Antenna Processing with Matrix Decomposition Using FPGA Based Application Specific Integrated Processors, Proceeding of the SDR 04 Technical Conference and Product Exposition, SDR Forum	2004

E. Prior Art References for the '450 Patent

Pursuant to Patent L.R. 3.3, the tables below identify the prior art items that

1 Defendants presently assert anticipate and/or render obvious the asserted claims of the
2 '450 Patent. Where applicable, this includes information about any alleged knowledge
3 of use of the invention in this country prior to the date of invention of the '450 Patent.
4

U.S. Patents or Patent Publications	Date of Issue or Publication
119. U.S. Patent No. 7,742,546 ("Ketchum 546")	June 22, 2010
120. U.S. Patent No. 7,450,532 ("Chae")	Nov. 11, 2008
121. U.S. Patent No. 7,236,748 ("Li 748")	June 26, 2007
122. U.S. Patent No. 7,492,829 ("Lin 829")	Feb. 17, 2009
123. U.S. Patent No. 7,570,696 ("Maltsev 696")	Aug. 4, 2009

Other Printed Publications	Date of Publication
124. WO 2004/038984 A2 ("Walton 984")	May 6, 2004
125. WO 2004/086712 A2 ("Walton 712")	Oct. 7, 2004

15 In addition to the above prior art references, Defendants identify the following
16 patents, printed publications, product literature, and other materials that are pertinent to
17 invalidity of the asserted claims. Defendants may rely on these references as
18 invalidating prior art, evidence of the knowledge of those skilled in the art, and/or
19 evidence to support a motivation to combine or modify other prior art. Defendants
20 reserve all rights to supplement or modify these invalidity contentions and to rely on
21 these references to prove invalidity of the asserted claims in a manner consistent with
22 the Federal Rules of Civil Procedure and the Rules of this Court.

Additional Prior Art References	Date of Issue or Publication
126. U.S. Pat. No. 7,710,925 ("Poon 925")	May 4, 2010
127. U.S. Pat. No. 7,280,645 ("Ketchum 625")	Oct. 9, 2007
128. U.S. Pat. No. 7,110,378	Sep. 19, 2006
129. U.S. Pat. No. 7,206,354	Apr. 17, 2007
130. U.S. Pat. No. 7,260,153	Aug. 21, 2007

131. U.S. Pat. No. 7,346,115	Mar. 18, 2008
132. U.S. Pat. No. 7,376,428	May 20, 2008
133. U.S. Pat. No. 7,443,925	Oct. 28, 2008
134. U.S. Pat. No. 7,447,270	Nov. 4, 2008
135. U.S. Pat. No. 7,460,494	Dec. 2, 2008
136. U.S. Pat. No. 7,486,470	Feb. 3, 2009
137. U.S. Pat. No. 7,529,310	May 5, 2009
138. U.S. Pat. No. 7,649,861	Jan. 19, 2010
139. U.S. Pat. No. 7,978,649	July 12, 2011
140. U.S. Pat. Pub. No. 2006/0068718 (“Li 718”)U.S. Patent No. (“”)	Mar. 30, 2006
141. U.S. Pat. Pub. No. 2004/0152458	Aug. 5, 2004
142. U.S. Pat. Pub. No. 2005/0063378	Mar. 24, 2005
143. U.S. Pat. Pub. No. 2005/0078762	Apr. 14, 2005
144. U.S. Pat. Pub. No. 2005/0111599	May 26, 2005
145. U.S. Pat. Pub. No. 2005/0141459	Jun. 30, 2005
146. U.S. Pat. Pub. No. 2005/0141540	Jun. 30, 2005
147. U.S. Pat. Pub. No. 2005/0180312	Aug. 18, 2005
148. U.S. Pat. Pub. No. 2007/0253476	Nov. 1, 2007
149. WO 2003069800	Aug. 21, 2003
150. WO2003073646	Sep. 4, 2003
151. WO2004038951	May 6, 2004
152. GILBERT STRANG, LINEAR ALGEBRA AND ITS APPLICATIONS, 2nd ed., Academic Press	1980
153. June Chul Roh and Bhaskar D. Rao, <i>An Efficient Feedback Method for MIMO Systems with Slowly Time-Varying Channels</i> , Roh and Rao, 2004 IEEE Wireless Communications and Networking Conference (IEEE Cat. No.04TH8733) (“Roh”).	Mar. 2004
154. B. Yang and J. F. Bohme, <i>Reducing The Computations Of The Singular Value Decomposition Array Given By Brent And Luk</i> , Vol. 12, No. 4, SIAM J. MATRIX ANAL. APPL., 713-725 (“Yang”)	Oct. 1991
155. IEEE 802.11a-1999 - IEEE Standard for Telecommunications and Information Exchange Between Systems - LAN/MAN Specific Requirements - Part 11: Wireless Medium Access Control (MAC) and physical layer (PHY) specifications: High Speed Physical Layer in the 5 GHz band	1999
156. O. Edfors et al., “OFDM Channel Estimation by Singular	July 1998

Value Decomposition,” IEEE Trans on Communications, 46(7), pp. 931-939.	
157. O. Edfors et al., “OFDM Channel Estimation by Singular Value Decomposition,” IEEE Trans on Communications, 46(7), pp. 931-939.	July 1998
158. O. Edfors et al., “OFDM Channel Estimation by Singular Value Decomposition,” IEEE Trans on Communications, 46(7), pp. 931-939.	July 1998
159. D. Bliss et al., “Environmental Issues for MIMO Capacity,” IEEE Trans on Signal Processing, 50(9), pp. 2128-2142.	Sep. 2002
160. G. Lebrun et al., “MIMO Transmission over a Time-Varying Channel Using SVD,” IEEE Global Telecommunications Conference, 2002 (GLOBECOM `02), pp. 414-418	Nov. 17, 2002
161. S. Ting et al., “Performance Analysis of MIMO Eigenmode Transmission System Under Realistic Channel and System Conditions,” IEICE Trans Commun, Vol. E86-B(10)	Oct. 2003
162. J. Kotecha et al., “Transmit Signal Design for Optimal Estimation of Correlated MIMO Channels,” IEEE Trans on Signal Processing, 52(2), pp. 546-557	Feb. 2004
163. G. Stuber et al., “Broadband MIMO-OFDM Wireless Communications,” Proc of the IEEE, 92(2), pp. 271-294.	Feb. 2004
164. G. Lebrun et al., “Channel Estimation for an SVD-MIMO System,” 2004 IEEE International Conf on Communications (IEEE Cat. No. 04CH37577), pp. 3025-3029.	June 20, 2004
165. Z. Zhou et al., “Design of adaptive modulation using imperfect CSI in MIMO systems,” ELECTRONICS LETTERS, 40(17)	Aug. 19, 2004
166. H.T. Nguyen et al., “Capacity and Performance of MIMO Systems under the Impact of Feedback Delay,” 2004 IEEE 15th International Symposium on Personal, Indoor and Mobile Radio Communications (IEEE Cat. No. 04TH8754), pp. 53-57.	Sep. 5, 2004
167. J. Du et al., “Estimation of Performance Loss Due to Delay in Channel Feedback in MIMO Systems,” IEEE 60th Vehicular Technology Conference, 2004, VTC2004-Fall 2004, pp. 1619-1622.	Sep. 26, 2004
168. Boyd Bangerter, et al., High-Throughput Wireless LAN Air Interface, Intel Technology Journal	Aug. 2003

169. André Bourdoux, et al. Preambles for MIMO channel estimation (r1), IMEC, Wireless Research	July 2004
170. Enhance the Beamforming Feature of the Multiple Antenna Tx Diversity, TSG-RAN Working Group 1 meeting No. 15, TSGR1#15(00)-1065	Aug. 22, 2000
171. Dhananjay A. Gore, Selecting an Optimal Set of Transmit Antennas for a Low Rank Matrix Channel, IEEE	2000
172. Christopher J. Hansen, Preambles, Beamforming, and the WWiSE Proposal (r1), IEEE	Jan. 17, 2005
173. Yingbo Hua, et al., Optimal Reduced-Rank Estimation and Filtering, IEEE	Mar. 2001
174. Taehyun Jeon, et al., Adaptive Modulation for MIMO-OFDM Systems, IEEE	Mar. 2004
175. John Ketchum, et al., PHY Design for Spatial Multiplexing MIMO WLAN, IEEE	Jul. 2004
176. John Ketchum, et al., System Description and Operating Principles for High Throughput Enhancements to 802.11, IEEE	Aug. 2004
177. John Ketchum, et al., 802.11 TGn High Throughput Proposal Compliance Statement, IEEE	Aug. 2004
178. Syed Aon Mujtaba, TGn Sync Proposal Technical Specification, IEEE	Aug. 2004
179. Daniel Nassani (Nissensohn), A Novel MIMO Transmission Method proposed herein as 802.11 TGn PHYsical Layer Element	Nov. 2003
180. Gregory G. Raleigh, et al., Spatio-Temporal Coding for Wireless Communication, IEEE	Mar. 1998
181. John S. Sadowsky, et al., WWiSE Preambles and MIMO Beamforming? (r1)	Jan. 15, 2005
182. Hemanth Sampath, Linear Precoding and Decoding for Multiple Input Multiple Output (MIMO) Wireless Channels, A Dissertation Submitted To the Dept. Of Electrical Engineering, Stanford University	Apr. 2001
183. Hilde Skjevling, Simulation and design of MIMO algorithms for correlated wireless channels, University of Oslo, Dept. of Informatics	Jul. 25, 2003
184. Gordon L Stüber, et al., Broadband MIMO-OFDM Wireless Communications, IEEE	Feb. 2004
185. Christopher J. Hansen, et al., Preambles, Beamforming, and the WWiSE Proposal, IEEE 802.11-05/1645r2	Jan. 17, 2005

186. M.P.Fitton, et al., Reconfigurable Antenna Processing with Matrix Decomposition Using FPGA Based Application Specific Integrated Processors, Proceeding of the SDR 04 Technical Conference and Product Exposition, SDR Forum	2004
---	------

F. Prior Art References for the '156 Patent

Pursuant to Patent L.R. 3.3, the tables below identify the prior art items that Defendants presently assert anticipate and/or render obvious the asserted claims of the '156 Patent. Where applicable, this includes information about any alleged knowledge of use of the invention in this country prior to the date of invention of the '156 Patent.

U.S. Patents or Patent Publications	Date of Issue or Publication
187. U.S. Patent No. 5,127,042 (“Gillig”)	June 30, 1992
188. U.S. Patent No. 5,737,703 (“Byrne I”)	April 7, 1998
189. U.S. Patent No. 6,922,559 (“Mohammed”)	July 26, 2005 (filed on April 2, 2002 and claims priority to provisional applications filed on February 26, 2001)
190. U.S. Patent No. 5,842,122 (“Schellinger”)	November 24, 1998

Other Printed Publications	Date of Publication
191. European Patent Application 0 660 626 A2 (“Byrne II”)	June 28, 1995
192. Japanese Unexamined Patent Application Publication No. H5-48526 (“Tateyama”)	February 26, 1993

In addition to the above prior art references, Defendants identify the following patents, printed publications, product literature, and other materials that are pertinent to invalidity of the asserted claims. Defendants may rely on these references as invalidating prior art, evidence of the knowledge of those skilled in the art, and/or

1 evidence to support a motivation to combine or modify other prior art. Defendants
 2 reserve all rights to supplement or modify these invalidity contentions and to rely on
 3 these references to prove invalidity of the asserted claims in a manner consistent with
 4 the Federal Rules of Civil Procedure and the Rules of this Court.

Additional Prior Art References	Date of Issue or Publication
193. U.S. Patent No. 5,533,099 (“Byrne III”)	July 2, 1996
194. U.S. Patent No. 5,873,033 (“Hjern”)	February 16, 1999
195. U.S. Patent No. 6,708,028 (“Byrne IV”)	March 16, 2004 (filed on November 15, 1996)
196. European Patent Application 0 660 627 A2 (“Byrne V”)	June 28, 1995
197. U.S. Patent No. 4,790,000 (“Kinoshita”)	December 6, 1988
198. U.S. Patent No. 5,212,684 (“MacNamee”)	May 18, 1993
199. U.S. Patent No. 5,659,598 (“Byrne VI”)	August 19, 1997
200. U.S. Patent No. 5,678,185 (“Chia”)	October 14, 1997
201. U.S. Patent No. 5,878,343 (“Robert”)	March 2, 1999
202. U.S. Patent No. 5,930,712 (“Byrne VII”)	July 27, 1999
203. U.S. Patent No. 6,188,908 (“Werbus”)	February 13, 2001 (filed on June 18, 1997)
204. U.S. Patent No. 6,430,413 (“Wedi”)	August 6, 2002 (filed on November 20, 1997)
205. U.S. Patent No. 6,400,946 (“Vazvan”)	June 4, 2002 (PCT filed on March 8, 1996)
206. International Application Publication No. WO 93/16560 (“Schellinger II”)	August 19, 1993

207. International Application Publication No. WO 96/25015 (“Hjern II”)	August 15, 1996
208. International Application Publication No. WO 96/38990 (“Pauli”)	December 5, 1996
209. International Application Publication No. WO 98/11743 (“Kruger”)	March 19, 1998
210. International Application Publication No. WO 00/07400 (“Wheatley”)	February 10, 2000
211. International Application Publication No. WO 00/24213 (“Fauconnier”)	April 27, 2000
212. U.S. Patent Publication No. 2001/0041594 A1 (“Arazi”)	November 15, 2001 (filed on February 16, 2001 and claims priority to provisional applications filed on April 7, 2000 and June 1, 2000)
213. International Application Publication No. WO 01/47290 (“Bell”)	June 28, 2001

G. Prior Art References for the ’432 Patent

Pursuant to Patent L.R. 3.3, the tables below identify the prior art items that Defendants presently assert anticipate and/or render obvious the asserted claims of the ’432 Patent. Where applicable, this includes information about any alleged knowledge of use of the invention in this country prior to the date of invention of the ’432 Patent.

U.S. Patents or Patent Publications	Date of Issue or Publication
214. U.S. Patent Pub. No. 2012/0294184 (“Jung”)	November 22, 2012 (PCT filed January 20, 2011)
215. U.S. Patent Pub. No. 2002/004371 (“Montgolfier”)	January 10, 2002
216. U.S. Patent Pub. No. 2009/0067386 (“Kitazoe”)	March 12, 2009

217. U.S. Patent Pub. No. 2006/0252377 (“Jeong”)	November 9, 2006
--	------------------

Other Printed Publications	Date of Publication
218. European Patent No. EP 1 950 986 A1 (“Yin”)	July 30, 2008

In addition to the above prior art references, Defendants identify the following patents, printed publications, product literature, and other materials that are pertinent to invalidity of the asserted claims. Defendants may rely on these references as invalidating prior art, evidence of the knowledge of those skilled in the art, and/or evidence to support a motivation to combine or modify other prior art. Defendants reserve all rights to supplement or modify these invalidity contentions and to rely on these references to prove invalidity of the asserted claims in a manner consistent with the Federal Rules of Civil Procedure and the Rules of this Court.

Additional Prior Art References	Date of Issue or Publication
219. U.S. Patent No. 6,487,420 (“Jonsson”)	November 26, 2002
220. U.S. Patent No. 6,845,238 (“Muller”)	January 18, 2005
221. U.S. Patent No. 6,847,420 (“Lazarev”)	January 25, 2005
222. U.S. Patent No. 8,774,135 (“Narasimha”)	July 8, 2014
223. U.S. Patent No. 8,891,394 (“Jung”)	November 18, 2014
224. U.S. Publication No. 2004/0228313 (“Cheng”)	November 18, 2004
225. U.S. Publication No. 2008/0045213 (“Norris”)	February 21, 2008
226. International Publication No. WO2004025983A1 (“Tolli”)	March 25, 2004
227. International Publication No. WO2008063109A1 (“Kazmi”)	May 29, 2008
228. International Publication No. WO2009077310A1 (“Lefebvre”)	June 25, 2009

229. “CR’s to TS 34.123-1 v5.3.0 Related to RRC Package 1 and 2 Test Cases,” Technical Specification Group Terminals TSGT#20(03)0101, Meeting #20, Hämeenlinna, Finland, 4.	June 6, 2003
230. Fodor et al., “Chapter 4 – Architecture and Protocol Support for Radio Resource Management (RRM),” Taylor & Francis Group LLC	2009
231. Mino et al., “Identification and Definition of Cooperation Schemes between RANs - First Draft.”	2004
232. European Patent Application Publication No. EP 1 720 373 A1 (“Jeong II”)	November 8, 2006
233. Nokia Corporation, “Addition of Optimised RACH Message Types,” 3GPP TSG RAN WG2 Meeting #71, R2-104524, Madrid, Spain, Aug. 23-27, 2010.	August 23-27, 2010
234. Nokia Corporation, Nokia Siemens Networks, “Analysis on RACH Signalling,” 3GPP TSG RAN WG2 Meeting #71 bis, R2-105713, Xian, China, Oct. 11-15, 2010.	October 11-15, 2010
235. “3rd Generation Partnership Project; Technical Specification Group Radio Access Network; Radio Resource Control (RRC); Protocol specification (Release 10)”, 3GPP TS 25.331 V10.2.0.	December 2010
236. Nokia Corporation, “RACH Signalling Optimisation Considerations,” 3GPP TSG RAN WG2 Meeting #72 bis, R2-110304, Dublin, Ireland, Jan. 17-21, 2011.	January 17-21, 2011

H. Prior Art References for the '435 Patent

Pursuant to Patent L.R. 3.3, the tables below identify the prior art items that Defendants presently assert anticipate and/or render obvious the asserted claims of the '435 Patent. Where applicable, this includes information about any alleged knowledge of use of the invention in this country prior to the date of invention of the '435 Patent.

U.S. Patents or Patent Publications	Date of Issue or Publication
237. U.S. Patent No. 5,541,609 (“Stutzman”)	July 30, 1996
238. U.S. Patent No. 6,018,646 (“Myllymaki”)	January 25, 2000 (filed August 22, 1997)

Other Printed Publications	Date of Publication
239. International Application Publication No. WO 95/03549 (“Carter”)	February 2, 1995
240. International Application Publication No. WO 02/05443 A2 (“Irvin”)	January 17, 2002 (filed June 20, 2001, designating the U.S., claiming priority to U.S. Patent Application No. 09/612,034 filed July 7, 2000)
241. European Patent Application Publication No. EP 1 091 498 A1 (“Baiker”)	April 11, 2001

Prior Art Systems or Offers for Sale	Using or Offering Party	Date of Use or Offer for Sale
242. Admitted Prior Art Devices and Systems of the ‘435 Patent (“’435 APA”)	Various	By Sept. 28, 2001

In addition to the above prior art references, Defendants identify the following patents, printed publications, product literature, and other materials that are pertinent to invalidity of the asserted claims. Defendants may rely on these references as invalidating prior art, evidence of the knowledge of those skilled in the art, and/or evidence to support a motivation to combine or modify other prior art. Defendants reserve all rights to supplement or modify these invalidity contentions and to rely on these references to prove invalidity of the asserted claims in a manner consistent with the Federal Rules of Civil Procedure and the Rules of this Court.

Additional Prior Art References	Date of Issue or Publication
--	-------------------------------------

243. Japanese Patent Application Publication No. JP 61-258550 A (“Murata”)	November 15, 1986
244. U.S. Patent No. 4,636,741 (“Mitzlaff”)	January 13, 1987
245. European Patent Application Publication No. EP 0 652 645 A1 (“Fischer”)	October 4, 1994
246. <i>Mobile Station-Base Station Compatibility Standard for Dual-Mode Wideband Spread Spectrum Cellular System + Telecommunications Systems Bulletin: Support for 14.4 kbps Data Rate and PCS Interaction for Wideband Spread Spectrum Cellular Systems</i> , TIA/EIA/IS-95-A + TSB74 (1996). (“TIA/EIA/IS-95-A”)	February 27, 1996
247. Federal Communication Commission, <i>Guidelines for Evaluating the Environmental Effects of Radiofrequency Radiation</i> , FCC 96-326 (1996). (“FCC 96-326”)	August 1, 1996
248. European Patent Application Publication No. EP 0 752 735 A1 (“Müller”)	January 8, 1997
249. William C. Y. Lee, <i>Mobile Communications Engineering: Theory and Applications</i> (McGraw Hill 1997). [incorporated by reference in ‘435 patent] (“Lee”)	October 1, 1997
250. European Patent Application Publication No. EP 0 843 421 A2 (“Pirhonen”)	May 20, 1998
251. International Application Publication No. WO 98/29968 A2 (“Bradley”)	July 9, 1998
252. U.S. Patent No. 5,805,067 (“Bradley II”)	September 8, 1998
253. U.S. Patent No. 5,815,820 (“Kiem”)	September 29, 1998
254. International Application Publication No. WO 99/05753 A1 (“Gumussoy”)	February 4, 1999
255. 3GPP2, <i>Physical Layer Standard for cdma2000 Spread Spectrum Systems</i> , C.S0002-0 v. 1 (1999). (“C.S0002-0 v1”)	July 1999
256. Robert F. Cleveland, Jr., Jerry L. Ulcek, Federal Communication Commission Office of Engineering and Technology, <i>Questions and Answers about Biological Effects and Potential Hazards of Radiofrequency Electromagnetic Fields</i> , OET Bulletin 56, Fourth Edition (1999). (“OET Bulletin 56”)	August 1999

257. U.S. Patent No. 5,949,369 (“Bradley III”)	September 7, 1999
258. U.S. Patent No. 5,999,142 (“Jang”)	December 7, 1999
259. U.S. Patent No. 6,002,943 (“Irvin II”)	December 14, 1999
260. European Patent Application Publication No. EP 0 977 304 A1 (“Werling”)	February 2, 2000
261. National Radiological Protection Board Independent Expert Group on Mobile Phones, Report on <i>Mobile Phones and Health</i> (Chairman Sir William Stewart, 2000). (“Stewart”)	April 28, 2000
262. U.S. Patent No. 6,072,784 (“Agrawal”)	June 6, 2000
263. U.S. Patent No. 6,087,994 (“Lechter”)	July 11, 2000
264. United Kingdom Patent Application No. GB 2 350 235 A (“Schemel”)	November 22, 2000
265. Maria Blettner, Gabriele Berg, <i>Are Mobile Phones Harmful?</i> , Acta Oncologica, 2000, 39:8, at 927-930. (“Blettner”)	2000
266. U.S. Patent No. 6,195,562 (“Pirhonen II”)	February 27, 2001
267. U.S. Patent No. 6,255,996 (“Wallace”)	July 3, 2001
268. International Application Publication No. WO 01/56110 A1 (“Jahn”)	August 2, 2001
269. U.S. Patent No. 6,408,187 (“Merriam”)	June 18, 2002 (filed May 14, 1999)
270. U.S. Patent No. 6,456,856 (“Werling II”)	September 24, 2002 (filed July 26, 1999)
271. U.S. Patent No. 6,498,924 (“Vogel”)	October 24, 2002 (filed October 27, 1998, issued December 24, 2002)
272. U.S. Patent Application Publication No. 2003/0064761 A1 (“Nevermann”)	April 3, 2003 (filed September 28, 2001)

1 **III. STATUTORY BASIS FOR INVALIDITY**

2 As explained below, and in the referenced claim charts, the asserted claims of
3 the '889 Patent, '554 Patent, '842 Patent, '862 Patent, '450 Patent, '156 Patent, '432
4 Patent, and '435 Patent are invalid for anticipation and/or obviousness. In some
5 instances, Defendants may have treated certain prior art as anticipatory where certain
6 elements are expressly, implicitly, or inherently present based on BNR's apparent
7 claim construction in BNR's infringement contentions. Defendants reserve the right to
8 contend that each of the anticipatory references renders the claims obvious either in
9 view of the reference alone or in combination with other references. The identification
10 of any patent or patent application should be deemed an identification of any
11 counterpart patent or application; the identification of any article should be deemed a
12 disclosure of any substantially similar article if published in some other form; and the
13 identification of any patent or article should be deemed an identification of any product
14 described therein.

15 **A. Invalidity Claim Charts for the '889 Patent**

16 The table below correlates exhibit numbers to the prior art items that Defendants
17 presently assert anticipate and/or render obvious the asserted claims of the '889 Patent.

18

Exhibit No.	Base Prior Art Reference / Prior Art System
A1	Fukiharu 598
A2	Numazawa
A3	Miyashita
A4	Seo
A5	Perez
A6	Mantjarvi
A7	Sparre

19
20
21
22
23
24

25 Defendants assert that the items of prior art identified above in connection with
26 Exhibits A1 to A7 anticipate one or more of the asserted claims of the '889 Patent
27 and/or render one or more of such asserted claims obvious in view of their own
28 disclosures and the knowledge, skill, and experience of a person of ordinary skill in the

art. Defendants assert that the claims identified below as anticipated are anticipated under at least Plaintiff's interpretation of the claims that Plaintiff appears to have adopted to support its infringement contentions. Defendants further assert that at least the combinations of prior art identified below render obvious one or more of the asserted claims of the '889 Patent. The identification of combinations below should not be taken to mean that the combinations are necessarily required to prove invalidity. To the contrary, certain claims may be anticipated under one claim interpretation and obvious under another. Further, if any element should be found to be missing from a particular item of prior art, Defendants assert that that item of prior art could be combined with other items of prior art that disclose that element.

1. Fukiharu 598 (A1) anticipates or renders obvious claims 1, 2, 4-6, 8, 12 under at least Plaintiff's apparent interpretation of the claims that Plaintiff appears to rely upon for its infringement contentions. In addition, as further explained in Exhibit A1, claims 1, 2, 4-6, 8, and 12 are obvious in view of Fukiharu 598 in combination with:
 - a. Numazawa (A2)
 - b. Seo (A4)
 - c. Perez (A5)
 - d. Mantyjarvi (A6)
 - e. Sparre (A7)
2. Numazawa (A2) anticipates or renders obvious claims 1, 2, 4-6, 8, 12 under at least Plaintiff's apparent interpretation of the claims that Plaintiff appears to rely upon for its infringement contentions. In addition, as further explained in Exhibit A2, claims 1, 2, 4-6, 8, and 12 are obvious in view of Numazawa in combination with:
 - a. Fukiharu 598 (A1)
 - b. Miyashita (A3)
 - c. Seo (A4)

- d. Perez (A5)
3. Miyashita (A3) anticipates or renders obvious claims 1, 2, 4-6, 8, 12 under at least Plaintiff's apparent interpretation of the claims that Plaintiff appears to rely upon for its infringement contentions. In addition, as further explained in Exhibit A3, claims 1, 2, 4-6, 8, and 12 are obvious in view of Miyashita in combination with:
 - a. Numazawa (A2)
 - b. Seo (A4)
 - c. Perez (A5)
4. Seo (A4) anticipates or renders obvious claims 1, 2, 4-6, 8, 12 under at least Plaintiff's apparent interpretation of the claims that Plaintiff appears to rely upon for its infringement contentions. In addition, as further explained in Exhibit A4, claims 1, 2, 4-6, 8, and 12 are obvious in view of Seo in combination with:
 - a. Fukiharu 598 (A1)
 - b. Numazawa (A2)
 - c. Miyashita (A3)
5. Perez (A5) anticipates or renders obvious claims 1, 2, 4-6, 8, 12 under at least Plaintiff's apparent interpretation of the claims that Plaintiff appears to rely upon for its infringement contentions. In addition, as further explained in Exhibit A5, claims 1, 2, 4-6, 8, and 12 are obvious in view of Perez in combination with:
 - a. Fukiharu 598 (A1)
 - b. Numazawa (A2)
 - c. Miyashita (A3)
6. Mantyjarvi (A6) anticipates or renders obvious claims 1, 2, 4-6, 8, 12 under at least Plaintiff's apparent interpretation of the claims that Plaintiff appears to rely upon for its infringement contentions. In addition, as further explained in Exhibit A6, claims 1, 2, 4-6, 8, and 12 are obvious in view of Mantyjarvi in combination with:
 - a. Fukiharu 598 (A1)

7. Sparre (A7) anticipates or renders obvious claims 1, 2, 4-6, 8, 12 under at least Plaintiff's apparent interpretation of the claims that Plaintiff appears to rely upon for its infringement contentions. In addition, as further explained in Exhibit A7, claims 1, 2, 4-6, 8, and 12 are obvious in view of Sparre in combination with:

a. Fukiharu 598 (A1)

A person of ordinary skill in the art at the time of the alleged invention would have been motivated to make the above-referenced combinations. Each of the references cited in an above-identified combination relates to aspects of making, using, and/or enabling the control and/or operation of mobile stations generally, and more specifically are directed to solving similar problems relating to performing operations on a mobile stations based on signals from a proximity detector or related device, and to conserving battery power in a mobile station. *See, e.g.*, Fukiharu 598 at ¶ 0001 (“The present invention relates to a lighting device controlling method for a mobile telephone that is light weight and has good portability, and that achieves a reduction in the consumption of electric power through controlling, through a touch sensor that is provided on a receiver portion section, the activation of a lighting device (backlight) for a liquid crystal display device or keypad portion that is equipped in the mobile telephone.”), ¶ 0018 (“The present invention, through the use of a structure as described above, enables a reduction in the consumption of battery power, through enabling the lighting devices to be turned OFF when the ear is caused to contact the receiver portion in order to hear the receiver sound during voice communications of a mobile telephone when the lighting devices (backlights) for a liquid crystal display device and keypad portion of a mobile telephone are lit, such as that night.”); Numazawa at ¶ Abstract (“To achieve reduced power consumption through stopping operation of unnecessary functions during use of a wireless terminal. A CPU 2 identifies start of a call state through a signal from a signal processing portion 3 for controlling communication with a base station, and identifies, through an output signal from detecting means 6, whether or not a user ear is in contact with a terminal. Upon identification of contact of the ear

to the terminal, controlling means 8 are caused to stop the supply of electric power, from a power supply 7, to displaying means 9 for providing information to a user, and lighting means 10, such as a black light.”), 0001 (“The present invention relates to a reduced power consumption controlling method in a wireless terminal for reducing power consumption by stopping operation of unnecessary functions during a call.”), ¶ 0005-0007 (“In the present invention, control is such that, upon determination that the wireless terminal is in a call, operation of functions believe be unnecessary, due to the user of the terminal being in a call, is stopped, and upon termination of the call, operation of the stopped functions is restarted. Additionally, because it is envisioned that there will also be cases where, even during a call, the face of the user may be separated from the receiver of the terminal, control is performed so as to enable restarting of the operations of the functions that had been stopped as unnecessary, through detecting whether or not the user of the terminal has the receiver in contact with an ear. The achievement of reduced power consumption through stopping operation of functions that become unnecessary in use of the terminal, as described above, can be anticipated to have the effect of extending the life of the power supply, such as a battery.”); Miyashita at 1:58-63 (“The present invention is directed to solving the problem set forth above. It is therefore an object of the present invention to provide a portable telephone set which can shut off the power supply for a display portion while a content of the display will not be seen during speaking, and thus can reduce power consumption.”), 2:6-11 (“In the preferred construction the detector is a gyro. The control apparatus may shut off the power supply for the display when the detector detects the main body at a substantially vertical position. On the other hand, the control may initiate power supply for the display when the detector detects the main body at a substantially horizontal position.”); Seo at 1:36-42 (“It is hence a primary object of the invention to present a novel cordless telephone capable of, by solving the above mentioned technical problems, stopping the display action by the display device while the handset is in service so as to minimize the wasteful consumption of the electric

power supplied from the battery or the like.”), 3:64-4:5 (When the receiver 6 is not in contact with the user's ear, the light emitting element 3 lights up at step n8. In this state, when the user touches the receiver 6 of the handset by the ear, it is detected by the piezoelectric element 7, and the detection signal is sent out to the control circuit 11. The control circuit 11, on the basis of this detection signal, sends out a stop signal to the driver 12. Thus, driving of the driver 12 is stopped, and the light emitting element 3 is extinguished at step n7.”); Sparre at 1 (“More specifically, the invention is directed at a new and inventive way of preserving electric power in such a portable electric apparatus by bringing the display to its inactive state whenever appropriate.”), 6 (“The purpose of the present invention is to propose an improved solution to the problem of preserving electric power in a portable electric apparatus having a liquid crystal display. In particular, the invention aims at achieving such power preservation at a lower cost and with improved accuracy, as compared to the prior art solutions. According to the invention, the portable electric apparatus is provided with a proximity detector, which is arranged to detect when an external object is very close to a specific portion of the apparatus (for instance less than 3 cm from the display). The external object may be the user's ear (when the telephone is held in a normal position for conversation), or the interior walls of a pocket or bag, in which the telephone has been placed by the user. In all circumstances, the presence of such an external object indicates that the apparatus is not in a position, where it is useful to keep the display turned on, since the user is physically prevented from visual access to the display. Therefore, when the proximity detector has detected the presence of the external object, the display may be powered off or present less visual information.”); Mantyjärvi at Abstract (“The present invention relates to a terminal for a communication system. The terminal includes detector means 7, 8 that are arranged to detect a contact between at least one surface of the terminal and the skin of the user. At least one function of the terminal is arranged to be controlled based on a signal generated by the detecting means in response to the detection. The sensor may be resistive, sensing galvanic skin resistance across linear contacts 7, 8 or

could be a capacitive proximity sensor, or may be pressure sensitive.”), 9:5-8 (“The station may also be switched between different modes of operation or even on and off based on the output signal received from the detecting means. The lighting of the keypad and/or the display may be controlled based on this information.”); Perez at [0005] (“A method and apparatus for display power management in a portable communication device can provide additional battery savings to enable increased talk times and standby times without altering current battery technology.”), [0013] (“Referring to FIG. 1, a portable communication product 10 such as a cellular phone includes a transceiver radio having a microphone 20, an earpiece 22, a keypad 18 and a display 12 (such as a color display) coupled to the transceiver radio. The portable communication product 10 further includes at least one sensor (24, 26, 28 or 30) and a processor 16. The sensor can be used for detecting a user condition of the portable communication device such as a talk condition when the user is assumed to be talking on the portable communication device. The processor 16 can be programmed to at least reduce power provided to the display 12 when the sensor detects the talk condition. The processor 16 can also turn off power to the display 12 during a talk condition if desired.”).

The combined teachings of these references, the knowledge of one of ordinary skill in the art at the time of the alleged invention, and the nature of the problem to be solved as a whole, would have suggested the alleged invention to one of ordinary skill in the art, as well as a reasonable likelihood of success in making the above-referenced combinations. The combinations would constitute, at least, combining prior art elements according to known methods to yield predictable results, a simple substitution of one known element for another to obtain predictable results, the use of a known technique to improve similar devices in the same way, the application of a known technique to a known device ready for improvement to yield a predictable result, and obvious to try.

B. Invalidity Claim Charts for the '554 Patent

1 The table below correlates exhibit numbers to the prior art items that Defendants
2 presently assert anticipate and/or render obvious the asserted claims of the '554 Patent.

Exhibit No.	Base Prior Art Reference / Prior Art System
B1	Fukiharu 598
B2	Numazawa
B3	Miyashita
B4	Seo
B5	Perez
B6	Mantjarvi
B7	Sparre

3
4
5
6
7
8
9 Defendants assert that the items of prior art identified above in connection with
10 Exhibits B1 to B7 anticipate one or more of the asserted claims of the '554 Patent
11 and/or render one or more of such asserted claims obvious in view of their own
12 disclosures and the knowledge, skill, and experience of a person of ordinary skill in the
13 art. Defendants assert that the claims identified below as anticipated are anticipated
14 under at least Plaintiff's apparent interpretation of the claims that Plaintiff appears to
15 have adopted to support its infringement contentions. Defendants further assert that at
16 least the combinations of prior art identified below render obvious one or more of the
17 asserted claims of the '554 Patent. The identification of combinations below should
18 not be taken to mean that the combinations are necessarily required to prove invalidity.
19 To the contrary, certain claims may be anticipated under one claim interpretation and
20 obvious under another. Further, if any element should be found to be missing from a
21 particular item of prior art, Defendants assert that that item of prior art could be
22 combined with other items of prior art that disclose that element.

- 23
24
25
26
1. Fukiharu 598 (B1) anticipates or renders obvious claims 1, 2, 4, 5, 7, 8, and 14 under at least Plaintiff's apparent interpretation of the claims that Plaintiff appears to rely upon for its infringement contentions. In addition, as further explained in Exhibit B1, claims 1, 2, 4, 5, 7, 8, and 14 are obvious in view of Fukiharu 598 in combination with:

- 27
28
- a. Numazawa (B2)

- b. Seo (B4)
 - c. Perez (B5)
 - d. Mantyjarvi (B6)
 - e. Sparre (B7)
2. Numazawa (B2) anticipates or renders obvious claims 1, 2, 4, 5, 7, 8, and 14 under at least Plaintiff's apparent interpretation of the claims that Plaintiff appears to rely upon for its infringement contentions. In addition, as further explained in Exhibit B2, the claims 1, 2, 4, 5, 7, 8, and 14 are obvious in view of Numazawa in combination with:
- a. Fukiharu 598 (B1)
 - b. Miyashita (B3)
 - c. Seo (B4)
 - d. Perez (B5)
3. Miyashita (B3) anticipates or renders obvious claims 1, 2, 4, 5, 7, 8, and 14 under at least Plaintiff's apparent interpretation of the claims that Plaintiff appears to rely upon for its infringement contentions. In addition, as further explained in Exhibit B3, claims 1, 2, 4, 5, 7, 8, and 14 are obvious in view of Miyashita in combination with:
- a. Numazawa (B2)
 - b. Seo (B4)
 - c. Perez (B5)
4. Seo (B4) anticipates or renders obvious claims 1, 2, 4, 5, 7, 8, and 14 under at least Plaintiff's apparent interpretation of the claims that Plaintiff appears to rely upon for its infringement contentions. In addition, as further explained in Exhibit B4, claims 1, 2, 4, 5, 7, 8, and 14 are obvious in view of Seo in combination with:
- a. Fukiharu 598 (B1)
 - b. Numazawa (B2)
 - c. Miyashita (B3)

5. Perez (B5) anticipates or renders obvious claims 1, 2, 4, 5, 7, 8, and 14 under at least Plaintiff's apparent interpretation of the claims that Plaintiff appears to rely upon for its infringement contentions. In addition, as further explained in Exhibit B5, claims 1, 2, 4, 5, 7, 8, and 14 are obvious in view of Perez in combination with:
 - a. Fukiharu 598 (B1)
 - b. Numazawa (B2)
 - c. Miyashita (B3)
6. Mantyarvi (B6) anticipates or renders obvious claims 1, 2, 4, 5, 7, 8, and 14 under at least Plaintiff's apparent interpretation of the claims that Plaintiff appears to rely upon for its infringement contentions. In addition, as further explained in Exhibit B6, claims 1, 2, 4, 5, 7, 8, and 14 are obvious in view of Mantyarvi in combination with:
 - a. Fukiharu 598 (B1)
7. Sparre (B7) anticipates or renders obvious claims 1, 2, 4, 5, 7, 8, and 14 under at least Plaintiff's apparent interpretation of the claims that Plaintiff appears to rely upon for its infringement contentions. In addition, as further explained in Exhibit B7, claims 1, 2, 4, 5, 7, 8, and 14 are obvious in view of Sparre in combination with:
 - a. Fukiharu 598 (B1)

A person of ordinary skill in the art at the time of the alleged invention would have been motivated to make the above-referenced combinations. Each of the references cited in an above-identified combination relates to aspects of making, using, and/or enabling the control and/or operation of mobile stations generally, and more specifically are directed to solving similar problems relating to performing operations on a mobile stations based on signals from a proximity detector or related device, and to conserving battery power in a mobile station. *See, e.g.*, Fukiharu 598 at ¶ 0001 (“The present invention relates to a lighting device controlling method for a mobile telephone that is light weight and has good portability, and that achieves a reduction in the

consumption of electric power through controlling, through a touch sensor that is provided on a receiver portion section, the activation of a lighting device (backlight) for a liquid crystal display device or keypad portion that is equipped in the mobile telephone.”), ¶ 0018 (“The present invention, through the use of a structure as described above, enables a reduction in the consumption of battery power, through enabling the lighting devices to be turned OFF when the ear is caused to contact the receiver portion in order to hear the receiver sound during voice communications of a mobile telephone when the lighting devices (backlights) for a liquid crystal display device and keypad portion of a mobile telephone are lit, such as that night.”); Numazawa at ¶ Abstract (“To achieve reduced power consumption through stopping operation of unnecessary functions during use of a wireless terminal. A CPU 2 identifies start of a call state through a signal from a signal processing portion 3 for controlling communication with a base station, and identifies, through an output signal from detecting means 6, whether or not a user ear is in contact with a terminal. Upon identification of contact of the ear to the terminal, controlling means 8 are caused to stop the supply of electric power, from a power supply 7, to displaying means 9 for providing information to a user, and lighting means 10, such as a black light.”), 0001 (“The present invention relates to a reduced power consumption controlling method in a wireless terminal for reducing power consumption by stopping operation of unnecessary functions during a call.”), ¶ 0005-0007 (“In the present invention, control is such that, upon determination that the wireless terminal is in a call, operation of functions believe be unnecessary, due to the user of the terminal being in a call, is stopped, and upon termination of the call, operation of the stopped functions is restarted. Additionally, because it is envisioned that there will also be cases where, even during a call, the face of the user may be separated from the receiver of the terminal, control is performed so as to enable restarting of the operations of the functions that had been stopped as unnecessary, through detecting whether or not the user of the terminal has the receiver in contact with an ear. The achievement of reduced power consumption through stopping

operation of functions that become unnecessary in use of the terminal, as described above, can be anticipated to have the effect of extending the life of the power supply, such as a battery.”); Miyashita at 1:58-63 (“The present invention is directed to solving the problem set forth above. It is therefore an object of the present invention to provide a portable telephone set which can shut off the power supply for a display portion while a content of the display will not be seen during speaking, and thus can reduce power consumption.”), 2:6-11 (“In the preferred construction the detector is a gyro. The control apparatus may shut off the power supply for the display when the detector detects the main body at a substantially vertical position. On the other hand, the control may initiate power supply for the display when the detector detects the main body at a substantially horizontal position.”); Seo at 1:36-42 (“It is hence a primary object of the invention to present a novel cordless telephone capable of, by solving the above mentioned technical problems, stopping the display action by the display device while the handset is in service so as to minimize the wasteful consumption of the electric power supplied from the battery or the like.”), 3:64-4:5 (When the receiver 6 is not in contact with the user's ear, the light emitting element 3 lights up at step n8. In this state, when the user touches the receiver 6 of the handset by the ear, it is detected by the piezoelectric element 7, and the detection signal is sent out to the control circuit 11. The control circuit 11, on the basis of this detection signal, sends out a stop signal to the driver 12. Thus, driving of the driver 12 is stopped, and the light emitting element 3 is extinguished at step n7.”); Sparre at 1 (“More specifically, the invention is directed at a new and inventive way of preserving electric power in such a portable electric apparatus by bringing the display to its inactive state whenever appropriate.”), 6 (“The purpose of the present invention is to propose an improved solution to the problem of preserving electric power in a portable electric apparatus having a liquid crystal display. In particular, the invention aims at achieving such power preservation at a lower cost and with improved accuracy, as compared to the prior art solutions. According to the invention, the portable electric apparatus is provided with a proximity detector, which is

arranged to detect when an external object is very close to a specific portion of the apparatus (for instance less than 3 cm from the display). The external object may be the user's ear (when the telephone is held in a normal position for conversation), or the interior walls of a pocket or bag, in which the telephone has been placed by the user. In all circumstances, the presence of such an external object indicates that the apparatus is not in a position, where it is useful to keep the display turned on, since the user is physically prevented from visual access to the display. Therefore, when the proximity detector has detected the presence of the external object, the display may be powered off or present less visual information.”); Mantyjarvi at Abstract (“The present invention relates to a terminal for a communication system. The terminal includes detector means 7, 8 that are arranged to detect a contact between at least one surface of the terminal and the skin of the user. At least one function of the terminal is arranged to be controlled based on a signal generated by the detecting means in response to the detection. The sensor may be resistive, sensing galvanic skin resistance across linear contacts 7, 8 or could be a capacitive proximity sensor, or may be pressure sensitive.”), 9:5-8 (“The station may also be switched between different modes of operation or even on and off based on the output signal received from the detecting means. The lighting of the keypad and/or the display may be controlled based on this information.”); Perez at [0005] (“A method and apparatus for display power management in a portable communication device can provide additional battery savings to enable increased talk times and standby times without altering current battery technology.”), [0013] (“Referring to FIG. 1, a portable communication product 10 such as a cellular phone includes a transceiver radio having a microphone 20, an earpiece 22, a keypad 18 and a display 12 (such as a color display) coupled to the transceiver radio. The portable communication product 10 further includes at least one sensor (24, 26, 28 or 30) and a processor 16. The sensor can be used for detecting a user condition of the portable communication device such as a talk condition when the user is assumed to be talking on the portable communication device. The processor 16 can be programmed to at least

1 reduce power provided to the display 12 when the sensor detects the talk condition. The
2 processor 16 can also turn off power to the display 12 during a talk condition if
3 desired.”).

4 The combined teachings of these references, the knowledge of one of ordinary
5 skill in the art at the time of the alleged invention, and the nature of the problem to be
6 solved as a whole, would have suggested the alleged invention to one of ordinary skill
7 in the art, as well as a reasonable likelihood of success in making the above-referenced
8 combinations. The combinations would constitute, at least, combining prior art
9 elements according to known methods to yield predictable results, a simple substitution
10 of one known element for another to obtain predictable results, the use of a known
11 technique to improve similar devices in the same way, the application of a known
12 technique to a known device ready for improvement to yield a predictable result, and
13 obvious to try.

14 **C. Invalidity Claim Charts for the '842 Patent**

15 The table below correlates exhibit numbers to the prior art items that Defendants
16 presently assert anticipate and/or render obvious the asserted claims of the '842 Patent.

17 Exhibit No.	Base Prior Art Reference / Prior Art System
18 C1	IEEE 802.11a-1999
19 C2	Khandani
20 C3	Webster
21 C4	Jones
22 C5	Ogawa
23 C6	Shearer
24 C7	Boer

25 Defendants assert that the items of prior art identified above in connection with
26 Exhibits C1 to C7 anticipate one or more of the asserted claims of the '842 Patent
27 and/or render one or more of such asserted claims obvious in view of their own
28 disclosures and the knowledge, skill, and experience of a person of ordinary skill in the
art. Defendants assert that the claims identified below as anticipated are anticipated
under at least Plaintiff's apparent interpretation of the claims that Plaintiff appears to

have adopted to support its infringement contentions. Defendants further assert that at least the combinations of prior art identified below render obvious one or more of the asserted claims of the '842 Patent. The identification of combinations below should not be taken to mean that the combinations are necessarily required to prove invalidity. To the contrary, certain claims may be anticipated under one claim interpretation and obvious under another. Further, if any element should be found to be missing from a particular item of prior art, Defendants assert that that item of prior art could be combined with other items of prior art that disclose that element.

1. IEEE 802.11a-1999 anticipates claims 1, 8, 11, 14, and 19 under at least Plaintiff's apparent interpretation of the claims that Plaintiff appears to rely upon for its infringement contentions. In addition, as further explained in Exhibit C1, the following claims are obvious under one or more interpretations in view of IEEE 802.11a-1999 in combination with Khandani:
 - a. Claims 1-4, 8, 11, 14, and 19.
2. Khandani anticipates claims 1 and 4 under at least Plaintiff's apparent interpretation of the claims that Plaintiff appears to rely upon for its infringement contentions. In addition, as further explained in Exhibit C2, the following claims are obvious under one or more interpretations in view of Khandani in combination with one or more of IEEE 802.11a-1999, Webster, Jones, Ogawa, Shearer, and/or Boer:
 - b. Claims 1-4, 8, 11, 14 and 19.
3. Webster anticipates claims 1-3, 8, 11, and 14 under at least Plaintiff's apparent interpretation of the claims that Plaintiff appears to rely upon for its infringement contentions. In addition, as further explained in Exhibit C3, the following claims are obvious under one or more interpretations in view of Webster in combination with Khandani:
 - c. Claims 1-4, 8, 11, 14 and 19.
4. Jones anticipates claims 1-3, 8, 11, 14, 19 under at least Plaintiff's apparent interpretation of the claims that Plaintiff appears to rely upon for its infringement contentions. In addition, as further explained in Exhibit C4, the following claims are obvious under one or more interpretations in view of Jones in combination with Khandani:

- d. Claims 1-4, 8, 11, 14, and 19.
5. Ogawa anticipates claims 1-3, 8, 11, 14, and 19 under at least Plaintiff's apparent interpretation of the claims that Plaintiff appears to rely upon for its infringement contentions. In addition, as further explained in Exhibit C5, the following claims are obvious under one or more interpretations in view of Ogawa in combination with Khandani:
 - e. Claims 1-4, 8, 11, 14, and 19.
6. Shearer anticipates claims 1-4, 8, 11, 14, and 19 under at least Plaintiff's apparent interpretation of the claims that Plaintiff appears to rely upon for its infringement contentions. In addition, as further explained in Exhibit C6, the following claims are obvious under one or more interpretations in view of Shearer in combination with Khandani:
 - f. Claims 1-4, 8, 11, 14, and 19.
7. Boer anticipates claims 1-3, 8, 11, 14, and 19 under at least Plaintiff's apparent interpretation of the claims that Plaintiff appears to rely upon for its infringement contentions. In addition, as further explained in Exhibit C7, the following claims are obvious under one or more interpretations in view of Shearer in combination with Khandani:
 - g. Claims 1-4, 8, 11, 14, and 19.
8. IEEE 802.11a-1999 anticipates claims 1, 8, 11, 14, and 19 under at least Plaintiff's apparent interpretation of the claims that Plaintiff appears to rely upon for its infringement contentions. In addition, as further explained in Exhibit C1, the following claims are obvious under one or more interpretations in view of IEEE 802.11a-1999 in combination with Webster and Khandani:
 - h. Claims 1-4, 8, 11, 14, and 19.
9. IEEE 802.11a-1999 anticipates claims 1, 8, 11, 14, and 19 under at least Plaintiff's apparent interpretation of the claims that Plaintiff appears to rely upon for its infringement contentions. In addition, as further explained in Exhibit C1, the following claims are obvious under one or more interpretations in view of IEEE 802.11a-1999 in combination with Jones and Khandani:
 - i. Claims 1-4, 8, 11, 14, and 19.

10. IEEE 802.11a-1999 anticipates claims 1, 8, 11, 14, and 19 under at least Plaintiff's apparent interpretation of the claims that Plaintiff appears to rely upon for its infringement contentions. In addition, as further explained in Exhibit C1, the following claims are obvious under one or more interpretations in view of IEEE 802.11a-1999 in combination with Ogawa and Khandani:

j. Claims 1-4, 8, 11, 14, and 19.

11. IEEE 802.11a-1999 anticipates claims 1, 8, 11, 14, and 19 under at least Plaintiff's apparent interpretation of the claims that Plaintiff appears to rely upon for its infringement contentions. In addition, as further explained in Exhibit C1, the following claims are obvious under one or more interpretations in view of IEEE 802.11a-1999 in combination with Shearer and Khandani:

k. Claims 1-4, 8, 11, 14, and 19.

A person of ordinary skill in the art at the time of the alleged invention would have found it obvious to combine IEEE 802.11a-1999, Webster, Jones, Ogawa, Shearer, Boer, and Khandani at least because they relate to the use of OFDM (i.e. multi-carrier modulation) in a wireless communication system, and address common problems, including, for example the selection and generation of constellation points for transmission. A person of ordinary skill in the art at the time of the alleged invention would have also found it obvious to combine IEEE 802.11a-1999, Webster, Jones, Ogawa, Shearer, and/or Boer with Khandani because each teaches a complementary method, which when put together yields no more than one would expect from such an arrangement. Moreover, design incentives and market forces, such as the advantages of creating a more desirable product and the effects of demands known to the design community or present in the marketplace, would have prompted such modifications or combinations. The combined teachings of these references, the teachings of Khandani and the IEEE 802.11 family of standards, including the IEEE 802.11a-1999 standard, the knowledge of one of ordinary skill in the art, and the nature of the problem to be solved as a whole, would have suggested the claimed invention to one of ordinary skill in the art, as well as a reasonable likelihood of success in making

1 the above-referenced combinations.

2 **D. Invalidity Claim Charts for the '862 Patent**

3 The table below correlates exhibit numbers to the prior art items that Defendants
4 presently assert anticipate and/or render obvious the asserted claims of the '862 Patent.

5

6 Exhibit No.	Base Prior Art Reference / Prior Art System
7 D1	Li 718
8 D2	Poon 925
9 D3	Roh
10 D4	Yang
11 D5	Maltsev 696
12 D6	Li 748
13 D7	Lin 829
14 D8	Ketchum 625

15 Defendants assert that the items of prior art identified above in connection with
16 Exhibits D1 to D8 anticipate one or more of the asserted claims of the '862 Patent
17 and/or render one or more of such asserted claims obvious in view of their own
18 disclosures and the knowledge, skill, and experience of a person of ordinary skill in the
19 art. Defendants assert that the claims identified below as anticipated are anticipated
20 under at least Plaintiff's apparent interpretation of the claims that Plaintiff appears to
21 have adopted to support its infringement contentions. Defendants further assert that at
22 least the combinations of prior art identified below render obvious one or more of the
23 asserted claims of the '862 Patent. The identification of combinations below should
24 not be taken to mean that the combinations are necessarily required to prove invalidity.
25 To the contrary, certain claims may be anticipated under one claim interpretation and
obvious under another. Further, if any element should be found to be missing from a
particular item of prior art, Defendants assert that that item of prior art could be
combined with other items of prior art that disclose that element.

- 26 1. Li 718 (Exhibit D1) anticipates or renders obvious claims 9, 10, 11, and 12
27 under at least Plaintiff's apparent interpretation of the claims that Plaintiff
28 appears to rely upon for its infringement contentions. In addition, as further

explained in Exhibit D1, claims 9, 10, 11, and 12 are obvious in view of Li 718 in combination with:

- a. Maltsev 696 (Exhibit D5), or
- b. Ketchum 625 (Exhibit D8).

2. Poon 925 (Exhibit D2) anticipates or renders obvious claims 9, 10, 11, and 12 under at least Plaintiff's apparent interpretation of the claims that Plaintiff appears to rely upon for its infringement contentions. In addition, as further explained in Exhibit D2, claims 9, 10, 11, and 12 are obvious in view of Poon 925 in combination with:

- c. Roh (Exhibit D3) and Yang (Exhibit D4), or
- d. Ketchum 625 (Exhibit D8).

3. Maltsev 696 (Exhibit D5) anticipates or renders obvious claims 9, 10, 11, and 12 under at least Plaintiff's apparent interpretation of the claims that Plaintiff appears to rely upon for its infringement contentions. In addition, as further explained in Exhibit D5, claims 9, 10, 11, and 12 are obvious in view of Maltsev 696 in combination with:

- e. Roh (Exhibit D3), or
- f. Ketchum 625 (Exhibit D8).

4. Li 748 (Exhibit D6) anticipates or renders obvious claims 9, 10, 11, and 12 under at least Plaintiff's apparent interpretation of the claims that Plaintiff appears to rely upon for its infringement contentions. In addition, as further explained in Exhibit D6, claims 9, 10, 11, and 12 are obvious in view of Li 748 in combination with:

- g. Maltsev 696 (Exhibit D5), or
- h. Ketchum 625 (Exhibit D8).

1 5. Lin 829 (Exhibit D7) anticipates or renders obvious claims 9, 10, 11, and 12
2 under at least Plaintiff's apparent interpretation of the claims that Plaintiff
3 appears to rely upon for its infringement contentions. In addition, as further
4 explained in Exhibit D7, claims 9, 10, 11, and 12 are obvious in view of Lin
5 829 in combination with:

6 i. Maltsev 696 (Exhibit D5), or

7 j. Ketchum 625 (Exhibit D8).

8
9 6. Ketchum 625 (Exhibit D8) anticipates or renders obvious claims 9, 10, 11,
10 and 12 under at least Plaintiff's apparent interpretation of the claims that
11 Plaintiff appears to rely upon for its infringement contentions.

12 A person of ordinary skill in the art would have been motivated to make the
13 above-referenced combinations. Each of the references cited in an above-identified
14 combination relates to aspects of making, using, and/or enabling the operation of
15 wireless communication devices that operate in compliance with standards, such as
16 IEEE 802.11, and that communicate using well-known wireless transmission
17 technologies, such as MIMO and OFDM. More specifically, the references relate to
18 algebraic techniques involving matrices, including matrix decomposition, for use in
19 connection with such wireless communication transmission technologies. The
20 combined teachings of these references, the knowledge of one of ordinary skill in the
21 art, and the nature of the problem to be solved as a whole, would have suggested the
22 claimed invention to one of ordinary skill in the art, as well as a reasonable likelihood
23 of success in making the above-referenced combinations.

24 **E. Invalidity Claim Charts for the '450 Patent**

25 The table below correlates exhibit numbers to the prior art items that Defendants
26 presently assert anticipate and/or render obvious the asserted claims of the '450 Patent.

27

Exhibit No.	Base Prior Art Reference / Prior Art System
E1	Ketchum 546

28

E2	Chae
E3	Walton 984
E4	Walton 712
E5	Li 748
E6	Lin 829
E7	Maltsev 696

Defendants assert that the items of prior art identified above in connection with Exhibits E1 to E7 anticipate one or more of the asserted claims of the '450 Patent and/or render one or more of such asserted claims obvious in view of their own disclosures and the knowledge, skill, and experience of a person of ordinary skill in the art. Defendants assert that the claims identified below as anticipated are anticipated under at least Plaintiff's apparent interpretation of the claims that Plaintiff appears to have adopted to support its infringement contentions. Defendants further assert that at least the combinations of prior art identified below render obvious one or more of the asserted claims of the '450 Patent. The identification of combinations below should not be taken to mean that the combinations are necessarily required to prove invalidity. To the contrary, certain claims may be anticipated under one claim interpretation and obvious under another. Further, if any element should be found to be missing from a particular item of prior art, Defendants assert that that item of prior art could be combined with other items of prior art that disclose that element.

1. Ketchum 546 (Exhibit E1) anticipates or renders obvious claims 2, 3, 11, 12, 13, 21, and 22 under at least Plaintiff's apparent interpretation of the claims that Plaintiff appears to rely upon for its infringement contentions. In addition, as further explained in Exhibit E1, claims 2, 3, 11, 12, 13, 21, and 22 are obvious in view of Ketchum 546 in combination with:
 - a. Chae (Exhibit E2), or
 - b. Lin 829 (Exhibit E6).

2. Chae (Exhibit E2) anticipates or renders obvious claims 2, 3, 11, 12, 13, 21, and 22 under at least Plaintiff's apparent interpretation of the claims that Plaintiff appears to rely upon for its infringement contentions.
3. Walton 984 (Exhibit E3) anticipates or renders obvious claims 2, 3, 11, 12, 13, 21, and 22 under at least Plaintiff's apparent interpretation of the claims that Plaintiff appears to rely upon for its infringement contentions.
4. Walton 712 (Exhibit E4) anticipates or renders obvious claims 2, 3, 11, 12, 13, 21, and 22 under at least Plaintiff's apparent interpretation of the claims that Plaintiff appears to rely upon for its infringement contentions. In addition, as further explained in Exhibit E4, claims 2, 3, 11, 12, 13, 21, and 22 are obvious in view of Walton 712 in combination with:
 - c. Chae (Exhibit E2), or
 - d. Lin 829 (Exhibit E6).
5. Li 748 (Exhibit E5) anticipates or renders obvious claims 2, 3, 11, 12, 13, 21, and 22 under at least Plaintiff's apparent interpretation of the claims that Plaintiff appears to rely upon for its infringement contentions.
6. Lin 829 (Exhibit E6) anticipates or renders obvious claims 2, 3, 11, 12, 13, 21, and 22 under at least Plaintiff's apparent interpretation of the claims that Plaintiff appears to rely upon for its infringement contentions.
7. Maltsev 696 (Exhibit E7) anticipates or renders obvious claims 2, 3, 11, 12, 13, 21, and 22 under at least Plaintiff's apparent interpretation of the claims that Plaintiff appears to rely upon for its infringement contentions. In addition, as further explained in Exhibit E4, claims 2, 3, 11, 12, 13, 21, and 22 are obvious in view of Maltsev 696 in combination with:
 - e. Chae (Exhibit E2), or

1 f. Lin 829 (Exhibit E6).

2 A person of ordinary skill in the art would have been motivated to make the
3 above-referenced combinations. Each of the references cited in an above-identified
4 combination relates to aspects of making, using, and/or enabling the operation of
5 wireless communication devices that operate in compliance with standards, such as
6 IEEE 802.11, and that communicate using well-known wireless transmission
7 technologies, such as MIMO and OFDM. More specifically, the references relate to
8 algebraic techniques involving matrices, including matrix decomposition, for use in
9 connection with such wireless communication transmission technologies. The
10 combined teachings of these references, the knowledge of one of ordinary skill in the
11 art, and the nature of the problem to be solved as a whole, would have suggested the
12 claimed invention to one of ordinary skill in the art, as well as a reasonable likelihood
13 of success in making the above-referenced combinations.

14 **F. Invalidity Claim Charts for the '156 Patent**

15 The table below correlates exhibit numbers to the prior art items that Defendants
16 presently assert anticipate and/or render obvious the asserted claims of the '156 Patent.

17

18 Exhibit No.	Base Prior Art Reference / Prior Art System
19 F1	Gillig
20 F2	Byrne I
21 F3	Byrne II
22 F4	Mohammed
F5	Schellinger
F6	Tateyama

23 Defendants assert that the items of prior art identified above in connection with
24 Exhibits F1 to F6 anticipate one or more of the asserted claims of the '156 Patent
25 and/or render one or more of such asserted claims obvious in view of their own
26 disclosures and the knowledge, skill, and experience of a person of ordinary skill in the
27 art. Defendants assert that the claims identified below as anticipated are anticipated
28 under at least Plaintiff's apparent interpretation of the claims that Plaintiff appears to

have adopted to support its infringement contentions. Defendants further assert that at least the combinations of prior art identified below render obvious one or more of the asserted claims of the '156 Patent. The identification of combinations below should not be taken to mean that the combinations are necessarily required to prove invalidity. To the contrary, certain claims may be anticipated under one claim interpretation and obvious under another. Further, if any element should be found to be missing from a particular item of prior art, Defendants assert that that item of prior art could be combined with other items of prior art that disclose that element.

1. Gillig anticipates claims 1-2 under at least Plaintiff's apparent interpretation of the claims that Plaintiff appears to rely upon for its infringement contentions. In addition, as further explained in Exhibit F1, claims 1-2 are obvious under one or more interpretations in view of Gillig in combination with:
 - a. Bryne I
 - b. Mohammed
2. Byrne I anticipates claims 1-2 under at least Plaintiff's apparent interpretation of the claims that Plaintiff appears to rely upon for its infringement contentions. In addition, as further explained in Exhibit F2, claims 1-2 are obvious under one or more interpretations in view of Byrne I in combination with:
 - c. Schellinger
 - d. Mohammed
3. Byrne II anticipates claims 1-2 under at least Plaintiff's apparent interpretation of the claims that Plaintiff appears to rely upon for its infringement contentions. In addition, as further explained in Exhibit F3, claims 1-2 are obvious under one or more interpretations in view of Byrne II in combination with:
 - e. Schellinger
 - f. Mohammed
4. Mohammed anticipates claims 1-2 under at least Plaintiff's apparent

interpretation of the claims that Plaintiff appears to rely upon for its infringement contentions. In addition, as further explained in Exhibit F4, claims 1-2 are obvious under one or more interpretations in view of Mohammed in combination with:

g. Schellinger

5. Schellinger anticipates claims 1-2 under at least Plaintiff's apparent interpretation of the claims that Plaintiff appears to rely upon for its infringement contentions.
6. Tateyama anticipates claims 1-2 under at least Plaintiff's apparent interpretation of the claims that Plaintiff appears to rely upon for its infringement contentions. In addition, as further explained in Exhibit F6, claims 1-2 are obvious under one or more interpretations in view of Tateyama in combination with:

h. Schellinger

i. Byrne I

j. Mohammed

A person of ordinary skill in the art at the time of the alleged invention would have found it obvious to combine Gillig, Byrne I, Byrne II, Mohammed, Schellinger, and/or Tateyama at least because they relate to the use of inter-radio access technology handover for multimode handsets in wireless communication systems, and address common problems, including, for example the detection and criteria for system handover. A person of ordinary skill in the art at the time of the alleged invention would have also found it obvious to combine Gillig, Byrne I, Byrne II, Mohammed, Schellinger, and/or Tateyama because each teaches a complementary method, which when put together yields no more than one would expect from such an arrangement. Moreover, design incentives and market forces, such as the advantages of creating a more desirable product and the effects of demands known to the design community or present in the marketplace, would have prompted such modifications or combinations. The combined teachings of these references, the teachings of Gillig, Byrne I, Byrne II, Mohammed, Schellinger, and Tateyama, the knowledge of one of ordinary skill in the

1 art, and the nature of the problem to be solved as a whole, would have suggested the
2 claimed invention to one of ordinary skill in the art, as well as a reasonable likelihood
3 of success in making the above-referenced combinations.

4 **G. Invalidity Claim Charts for the '432 Patent**

5 The table below correlates exhibit numbers to the prior art items that Defendants
6 presently assert anticipate and/or render obvious the asserted claims of the '432 Patent.

7 Exhibit No.	Base Prior Art Reference / Prior Art System
8 G1	Jung
9 G2	Montgolfier
10 G3	Kitazoe
11 G4	Jeong
12 G5	Yin

13 Defendants assert that the items of prior art identified above in connection with
14 Exhibits G1 to G5 anticipate one or more of the asserted claims of the '432 Patent
15 and/or render one or more of such asserted claims obvious in view of their own
16 disclosures and the knowledge, skill, and experience of a person of ordinary skill in the
17 art. Defendants assert that the claims identified below as anticipated are anticipated
18 under at least Plaintiff's apparent interpretation of the claims that Plaintiff appears to
19 have adopted to support its infringement contentions. Defendants further assert that at
20 least the combinations of prior art identified below render obvious one or more of the
21 asserted claims of the '432 Patent. The identification of combinations below should
22 not be taken to mean that the combinations are necessarily required to prove invalidity.
23 To the contrary, certain claims may be anticipated under one claim interpretation and
24 obvious under another. Further, if any element should be found to be missing from a
25 particular item of prior art, Defendants assert that that item of prior art could be
26 combined with other items of prior art that disclose that element.

- 27 1. Jung (G1) anticipates claims 9 and 12 under at least Plaintiff's apparent
28 interpretation of the claims that Plaintiff appears to rely upon for its
infringement contentions. In addition, the following claims are obvious
under one or more interpretations in view of Jung in combination with:

- a. For claims 9 and 12, the prior art of Exhibit G4.
2. Montgolfier (G2) anticipates claims 9 and 12 under at least Plaintiff's apparent interpretation of the claims that Plaintiff appears to rely upon for its infringement contentions. In addition, the following claims are obvious under one or more interpretations in view of Montgolfier in combination with:
 - b. For claims 9 and 12, the prior art of Exhibits G1, G4, and G5.
3. Kitazoe (G3) anticipates claims 9 and 12 under at least Plaintiff's apparent interpretation of the claims that Plaintiff appears to rely upon for its infringement contentions. In addition, the following claims are obvious under one or more interpretations in view of Kitazoe in combination with:
 - c. For claims 9 and 12, the prior art of Exhibits G4.
4. Jeong (G4) anticipates claims 9 and 12 under at least Plaintiff's apparent interpretation of the claims that Plaintiff appears to rely upon for its infringement contentions. In addition, the following claims are obvious under one or more interpretations in view of Jeong in combination with:
 - d. For claims 9 and 12, the prior art of Exhibits G1, G2, G3.
5. Yin (G5) anticipates claims 9 and 12 under at least Plaintiff's apparent interpretation of the claims that Plaintiff appears to rely upon for its infringement contentions. In addition, the following claims are obvious under one or more interpretations in view of Yin in combination with:
 - e. For claims 9 and 12, the prior art of Exhibit G2.

A person of ordinary skill in the art would have been motivated to make the above-referenced combinations. Each of the references cited in an above-identified combination relates to aspects of making, using, and/or enabling the user equipment of a cellular network to relay messages containing neighboring cell measurements to the network. These measurements are uploaded as control signals over the RACH (for example, the control messages in Jeong (G4)). As space on the RACH is limited, various references describe decreasing or prioritizing the measurements included in the messages (for example, inter-frequency or intra-frequency measurements may be selected by the network as in Jung (G1), Montgolfier (G2), and Kitazoe (G3)). Some

1 of the references disclose a complete system for providing both measurement
2 prioritization functionality and transmission of control messages over RACH, while
3 others focus on selected aspects of such a system. The combined teachings of these
4 references, the knowledge of one of ordinary skill in the art, and the nature of the
5 problem to be solved as a whole, would have suggested the claimed invention to one of
6 ordinary skill in the art, as well as a reasonable likelihood of success in making the
7 above-referenced combinations.

8 Additionally, problems to be solved in the art at the time would lead one of
9 ordinary skill in the art to make the above listed combinations. For example, Jeong
10 indicates that including too much measurement information in the RACH message
11 “caus[es] and excessive increase in the size of the RACH message.” Jeong (G4), at
12 ¶ [0016]. This problem would lead those skilled in the art to consider methods of
13 decreasing or prioritizing the amount of measurement information contained in the
14 RACH message, as described in Jung (G1), Montgolfier (G2), and Kitazoe (G3).

15 **H. Invalidity Claim Charts for the '435 Patent**

16 The table below correlates exhibit numbers to the prior art items that Defendants
17 presently assert anticipate and/or render obvious the asserted claims of the '435 Patent.

18 Exhibit No.	Base Prior Art Reference / Prior Art System
19 H1	Irvin
20 H2	Myllymaki
21 H3	Baiker
22 H4	Stutzman
H5	Carter

23 Defendants assert that the items of prior art identified above in connection with
24 Exhibits H1 to H5 anticipate one or more of the asserted claims of the '435 Patent
25 and/or render one or more of such asserted claims obvious in view of their own
26 disclosures and the knowledge, skill, and experience of a person of ordinary skill in the
27 art. Defendants assert that the claims identified below as anticipated are anticipated
28 under at least Plaintiff's apparent interpretation of the claims that Plaintiff appears to

have adopted to support its infringement contentions. Defendants further assert that at least the combinations of prior art identified below render obvious one or more of the asserted claims of the '435 Patent. The identification of combinations below should not be taken to mean that the combinations are necessarily required to prove invalidity. To the contrary, certain claims may be anticipated under one claim interpretation and obvious under another. Further, if any element should be found to be missing from a particular item of prior art, Defendants assert that that item of prior art could be combined with other items of prior art that disclose that element.

1. Irvin (H1) anticipates or renders obvious claims 1, 2, 3, 6, and 8 under at least Plaintiff's apparent interpretation and its apparent interpretation of the claims that Plaintiff appears to rely upon for its infringement contentions. In addition, as further explained in Exhibit H1, claims 1, 2, 3, 6, and 8 are also rendered obvious by Irvin in combination with:
 - a. Myllymaki (H2);
 - b. Baiker (H3);
 - c. Stutzman (H4); and
 - d. Carter (H5).

2. Myllymaki (H2) anticipates or renders obvious claims 1, 2, 3, 6, and 8 under at least Plaintiff's apparent interpretation and its apparent interpretation of the claims that Plaintiff appears to rely upon for its infringement contentions. In addition, as further explained in Exhibit H2, claims 1, 2, 3, 6, and 8 are also rendered obvious by Myllymaki in combination with:
 - a. Irvin (H1);
 - b. Baiker (H3);
 - c. Stutzman (H4);
 - d. Carter (H5); and
 - e. '435 APA.

3. Baiker (H3) anticipates or renders obvious claims 1, 2, 3, 6, and 8 under at least Plaintiff's apparent interpretation and its apparent interpretation of the claims that Plaintiff appears to rely upon for its infringement contentions. In addition, as further explained in Exhibit H3, claims 1, 2, 3, 6, and 8 are also rendered obvious by Irvin in combination with:
 - a. Irvin (H1);
 - b. Myllymaki (H2);
 - c. Stutzman (H4);
 - d. Carter (H5); and
 - e. '435 APA.
4. Stutzman (H4) anticipates or renders obvious claims 1, 2, 3, 6, and 8 under at least Plaintiff's apparent interpretation and its apparent interpretation of the claims that Plaintiff appears to rely upon for its infringement contentions. In addition, as further explained in Exhibit H4, claims 1, 2, 3, 6, and 8 are also rendered obvious by Stutzman in combination with:
 - a. Irvin (H1);
 - b. Myllymaki (H2); and
 - c. Baiker (H3).
5. Carter (H5) anticipates or renders obvious claims 1, 2, 3, and 6 under at least Plaintiff's apparent interpretation and its apparent interpretation of the claims that Plaintiff appears to rely upon for its infringement contentions. In addition, as further explained in Exhibit H5, claims 1, 2, 3, 6, and 8 are also rendered obvious by Carter in combination with:
 - a. Irvin (H1);
 - b. Myllymaki (H2); and
 - c. Baiker (H3).

A person of ordinary skill in the art would have been motivated to make the

above-referenced combinations. Each of the references cited in an above-identified combination relates to aspects of making, using, and/or enabling the control and/or operation of, mobile telecommunications devices or portable cell phone devices that provide adjusted power functionality (including, for example, a network adjusted transmit power level) and proximity regulation functionality (including, for example, a proximity adjusted transmit power level) to a mobile telecommunication or portable cell phone device. Some of the references disclose a complete system for providing both provide adjusted power functionality and proximity regulation functionality in a mobile telecommunications devices or portable cell phone device, while others focus on selected aspects of such a system, including, e.g., proximity regulation functionality, a proximity adjusted transmit power level. The combined teachings of these references, the teachings of FCC rules and regulations, the AMPS, GSM, cdmaOne, UMTS, and GPRS standards, the knowledge of one of ordinary skill in the art, and the nature of the problem to be solved as a whole, would have suggested the claimed invention to one of ordinary skill in the art, as well as a reasonable likelihood of success in making the above-referenced combinations.

IV. LACK OF WRITTEN DESCRIPTION, LACK OF ENABLEMENT, INDEFINITENESS, IMPROPER DEPENDENCY

Subject to their reservation of rights, Defendants contend that the asserted claims are invalid under one or more sections of 35 U.S.C. § 112.

Section 112, 35 U.S.C., first paragraph requires that “[t]he specification shall contain a written description of the invention, and of the manner and process of making and using it, in such full, clear, concise, and exact terms as to enable any person skilled in the art to which it pertains, or with which it is most nearly connected, to make and use the same, and shall set forth the best mode contemplated by the inventor of carrying out his invention.”

The written description requirement of 35 U.S.C. §112, first paragraph, mandates that the “specification objectively demonstrate that the applicant actually

invented—was in possession of—the claimed subject matter.” *Ariad Pharm., Inc. v. Eli Lilly & Co.*, 598 F.3d 1336, 1349 (Fed. Cir. 2010). Furthermore, “actual ‘possession’ or reduction to practice outside of the specification is not enough.” *Id.* at 1352. A “description that merely renders the invention obvious does not satisfy the requirement” because “it is the specification itself that must demonstrate possession.” *Id.*

The enablement requirement of 35 U.S.C. § 112, first paragraph, requires that the specification of a patent teach those skilled in the art how to make and use the full scope of the claimed invention without undue experimentation. *Trs. of Boston Univ. v. Everlight Elecs. Co.*, 896F.3d 1357, 1362 (Fed. Cir. 2018).

Section 112, 35 U.S.C., second paragraph, requires that “[t]he specification shall conclude with one or more claims particularly pointing out and distinctly claiming the subject matter which the applicant regards as his invention.”

The asserted claims of the Asserted Patents are invalid for indefiniteness under §112 because they fail to inform, with reasonable certainty, those skilled in the art about the scope of the claimed invention. *See Nautilus, Inc. v. Biosig Instruments, Inc.*, 134 S. Ct. 2120 (2014). The definiteness requirement “mandates clarity” and is not satisfied merely because a patent claim is “amenable to construction.” *Id.* at 2129-30. Nor is it satisfied by a showing that a patent’s claims are not “insolubly ambiguous.” *Id.* As the Court explained, “[t]o tolerate imprecision just short of that rendering a claim insolubly ambiguous would diminish the definiteness requirement’s public-notice function and foster the innovation-discouraging zone of uncertainty against which th[e] Court has warned.” *Id.* (internal quotations and citations omitted). Instead, “a patent must be precise enough to afford clear notice of what is claimed, thereby appris[ing] the public of what is still open to them.” *Id.*

Section 112, 35 U.S.C., fourth paragraph requires that “a claim in dependent form shall contain a reference to a claim previously set forth and then specify a further limitation of the subject matter claimed. A claim in dependent form shall be construed

to incorporate by reference all the limitations of the claim to which it refers.”

In this case, under at least the claim interpretations upon which Plaintiff apparently relies for its infringement assertions, the asserted claims would be invalid for failure to satisfy the written description requirement because they would be drawn to subject matter that exceeds or otherwise differs from that which one of ordinary skill in the art would understand the named inventors to have had in their possession based on the written description. Accordingly, to the extent the claims are broadly interpreted to support Plaintiff’s infringement theories, the asserted claims are invalid for lack of written description.

A. 112 Issues for the ’889 Patent

1. 112, 1st paragraph, Written Description Issues for the ’889 Patent

Claim 1 recites “a proximity sensor adapted to generate a signal indicative of proximity of an external object” and “a microprocessor adapted to . . . receive the signal from the proximity sensor.” The specification of the ’889 Patent lacks any written description support for such a “signal” being generated by a proximity sensor and received by a microprocessor. Therefore, claim 1 of the ’889 Patent, and claims 2, 4, 5, and 6, which depend from claim 1, are invalid.

2. 112, 1st paragraph, Enablement Issues for the ’889 Patent

Claim 1 recites “a proximity sensor adapted to generate a signal indicative of proximity of an external object” and “a microprocessor adapted to . . . receive the signal from the proximity sensor.” The specification of the ’889 Patent does not disclose, or teach how to make and use “[a] mobile station” that includes, such a “signal” generated by a proximity sensor and received by a microprocessor. Therefore, claim 1 of the ’889 Patent, and claims 2, 4, 5, and 6, which depend from claim 1 are invalid.

3. 112, 2nd paragraph, Definiteness Issues for the ’889 Patent

Claim 1 recites “the proximity sensor begins detecting whether an external object is proximate substantially concurrently with the mobile station initiating an

outgoing wireless telephone call or receiving an incoming wireless telephone call.” Claim 8 recites “detecting whether an external object is proximate begins substantially concurrently with the mobile station initiating an outgoing wireless telephone call or receiving an incoming wireless telephone call.” The ’889 Patent does not describe or otherwise inform one of ordinary skill about what it means to begin detecting “substantially concurrently” with the mobile station initiating an outgoing wireless telephone call or receiving an incoming wireless telephone call. Therefore, at least claims 1 and 8, and claims 2, 4, 5, 6, and 12 which depend from claims 1 or 8, are indefinite under 35 U.S.C. § 112, second paragraph.

Claim 5 recites the “mobile station as recited in claim 1, wherein the proximity sensor is a mechanical proximity sensor, an optical sensor, or a range-detecting sensor.” The ’889 Patent does not describe or otherwise inform one of ordinary skill about the meaning and scope of “range-detecting sensor.” Therefore, claim 5 is indefinite under 35 U.S.C. § 112, second paragraph.

Claim 6 recites “the mobile station as recited in claim 1, wherein the proximity sensor is located proximate to the display.” The ’889 Patent does not describe or otherwise inform one of ordinary skill about what it means for a proximity sensor to be located “proximate” the display. Therefore, claim 6 is indefinite under 35 U.S.C. § 112, second paragraph.

Claims 1 and 8 recite “detecting whether an external object is proximate.” A person of ordinary skill in the art cannot determine the scope of the term “proximate” with reasonable certainty. Therefore, claims 1 and 8, and claims 2, 4, 5, and 6, which depend from claim 1, and claim 12, which depends from claim 8, are indefinite under 35 U.S.C. § 112, second paragraph.

Claim 1 recites “[a] mobile station,” but also a method limitation—“the proximity sensor begins detecting whether an external object is proximate substantially concurrently with the mobile station initiating an outgoing wireless telephone call or receiving an incoming wireless telephone call.” Claims 1, 2, 4, 5, and 6 of the ’889

Patent are, therefore, indefinite under 35 U.S.C. § 112, second paragraph, because they improperly recite both apparatus and method limitations.

Claim 1 recites “reduce power to the display *if* (i) the microprocessor determines that a call is active and (ii) the signal indicates the proximity of the external object (emphasis added)” and “the microprocessor reduces power to the display while the signal indicates the proximity of the external object *only if* the microprocessor determines that the wireless telephone call is active (emphasis added).” Claim 8 recites “reducing power consumption of a display of the mobile station *if* (i) a telephone call is determined to be active and (ii) the proximity of the external object is detected (emphasis added)” and “the power consumption of the display is reduced while the proximity of the external object is detected *only if* the wireless telephone call is determined to be active.” The ’889 Patent does not describe or otherwise inform one of ordinary skill in the art about whether these predicate conditions are the only conditions in which the microprocessor reduces power to the display. Therefore at least claims 1 and 8, and claims 2, 4, 5, 6, and 12 which depend from claims 1 or 8, are indefinite under 35 U.S.C. § 112, second paragraph.

B. 112 Issues for the ’554 Patent

1. 112, 1st paragraph, Written Description Issues for the ’554 Patent

Claims 1 and 14 recite “a proximity sensor adapted to generate a signal indicative of the existence of a first condition, the first condition being that an external object is proximate” and “a microprocessor adapted to . . . receive the signal from the activated proximity sensor.” The specification of the ’554 Patent lacks any written description support for such a “signal” being generated by a proximity sensor and received by a microprocessor. Therefore, claims 1 and 14 of the ’554 Patent, and claims 2, 4, 5, and 7, which depend from claim 1, are invalid.

2. 112, 1st paragraph, Enablement Issues for the ’554 Patent

Claims 1 and 14 recite “a proximity sensor adapted to generate a signal indicative of the existence of a first condition, the first condition being that an external object is proximate” and “a microprocessor adapted to . . . receive the signal from the activated proximity sensor.” The specification of the ’554 Patent does not disclose, or teach how to make and use “[a] mobile station” that includes, such a “signal” generated by a proximity sensor and received by a microprocessor. Therefore, claims 1 and 14 of the ’554 Patent, and claims 2, 4, 5, and 7, which depend from claim 1 are invalid.

3. 112, 2nd paragraph, Definiteness Issues for the ’554 Patent

Claim 5 recites the “mobile station as recited in claim 1, wherein the proximity sensor is a mechanical proximity sensor, an optical sensor, or a range-detecting sensor.” The ’554 Patent does not describe or otherwise inform one of ordinary skill about the meaning and scope of “range-detecting sensor.” Therefore, claim 5 is indefinite under 35 U.S.C. § 112, second paragraph.

Claim 7 recites “the proximity sensor begins detecting whether an external object is proximate substantially concurrently with the mobile station initiating an outgoing telephone call.” The ’554 Patent does not describe or otherwise inform one of ordinary skill about what it means to begin detecting “substantially concurrently” with the mobile station initiating an outgoing telephone. Therefore, claim 7 is indefinite under 35 U.S.C. § 112, second paragraph.

Claims 1 and 14 recite “the first condition being that an external object is proximate,” claim 8 recites “the proximity condition being that an external object is proximate,” and claim 14 recites “the determination whether the external object is proximate.” A person of ordinary skill in the art cannot determine the scope of the term “proximate” with reasonable certainty. Therefore, claims 1, 8, and 14, and claims 2, 4, 5, and 7, which depend from claim 1, are indefinite under 35 U.S.C. § 112, second paragraph.

Claim 1 recites “reduce power to the display *if* the signal from the activated proximity sensor indicates that the first condition exists (emphasis added).” Claim 8 recites “the mobile station reducing power consumption of a display of the mobile station *if* the activated proximity sensor indicates that the proximity condition exists (emphasis added).” Claim 14 recites “reduce power to the display *if* the signal from the activated proximity sensor indicates that the first condition exists (emphasis added).” The ’554 Patent does not describe or otherwise inform one of ordinary skill in the art about whether these predicate conditions are the only conditions in which the microprocessor reduces power to the display. Therefore at least claims 1, 8, and 14 and claims 2, 4, 5, 7 which depend from claims 1, 8, or 14 are indefinite under 35 U.S.C. § 112, second paragraph.

C. 112 Issues for the ’842 Patent

1. 112, 1st paragraph, Written Description Issues for the ’842 Patent

Claims 1, 2, 4, and 14 recite an “optimal extended long training sequence” with the property of “a minimal peak-to-average ratio” according to claim 1. Peak-to-average ratio is a property of a time domain sequence. Claims 1, 2, 4, 14, and claims 3, 8, and 11, which depend on claim 1, refer to the “optimal extended long training sequence” as being carried by one or more subcarriers, which is incompatible with being a time domain sequence. These claims are invalid for lack of enablement and lack of possession as the specification neither enables nor describes how to carry a time domain sequence on one or more subcarriers.

2. 112, 1st paragraph, Enablement Issues for the ’842 Patent

Claim 1 recites “[a] wireless communications device, comprising: a signal generator that generates an extended long training sequence; and . . . [an] Inverse Fourier Transformer [that] processes the extended long training sequence from the signal generator and provides an optimal extended long training sequence with a minimal peak-to-average ratio.” The specification of the ’842 Patent does not disclose, or teach how to make and use, “[a] wireless communications device” that can generate

“an optimal extended long training sequence with a minimal peak-to-average ratio” for “an Orthogonal Frequency Division Multiplexing scheme.” The specification of the ’842 Patent discusses two sequences that purport to have “a minimum peak-to-average power ratio” for the number of sub-carriers of the particular sequence, but it does not disclose how “[a] wireless communication device” can identify such a sequence. Therefore, claims 1, 3, 4, 8, 11, 14, and 19 of the ’842 Patent are invalid.

3. 112, 2nd paragraph, Definiteness Issues for the ’842 Patent

Claim 1 recites a “standard wireless networking configuration for an Orthogonal Frequency Division Multiplexing scheme.” The specification refers to 802.11a, 802.11g, 802.11n, but does not define what is meant by a “standard wireless networking configuration.” The ’842 patent does not describe or otherwise inform one of ordinary skill about what is meant by a “standard wireless networking configuration for an Orthogonal Frequency Division Multiplexing scheme.” Therefore, claim 1, and claims 3, 4, 8, 11, 14, and 19 which dependent from claim 1, are indefinite under 35 U.S.C. § 112, second paragraph, inasmuch as claim 1 recites “standard wireless networking configuration” without defining such a configuration.

Claim 14 recites a “legacy wireless local area network device” and a “legacy wireless networking protocol standard.” The specification refers to “legacy systems” and “devices that are compliant with older versions are considered to be legacy devices” but does not define what is meant by a “legacy wireless local area network device” nor “a legacy wireless networking protocol standard.” The ’842 patent does not describe or otherwise inform one of ordinary skill about what is meant by a “legacy wireless local area network device” nor “legacy wireless networking protocol standard.” Therefore, claim 14 is indefinite under 35 U.S.C. § 112, second paragraph, inasmuch as it recites “legacy wireless local area network device” and “legacy wireless networking protocol standard” without defining such a device and standard.

Claim 1 recites “an optimal extended long training sequence with a minimal peak-to-average ratio.” A person of ordinary skill in the art cannot determine the

scope of the term “minimal” with reasonable certainty. Therefore, claims 1, 3, 4, 8, 11, 14, and 19 are indefinite under 35 U.S.C. § 112, second paragraph.

Claims 1, 4, 14, and 19, and claim 2, from which claim 3 depends, recite “an optimal extended long training sequence.” A person of ordinary skill in the art cannot determine the scope of the term “optimal” with reasonable certainty. Therefore, claims 1, 3, 4, 8, 11, 14, and 19 are indefinite under 35 U.S.C. § 112, second paragraph.

D. 112 Issues for the '862 Patent

Claims 9, 10, 11, and 12 of the '862 Patent are invalid for indefiniteness to the extent the phrase “a baseband processing module operable to receive a preamble sequence carried by the baseband signal” is construed to be governed by 35 U.S.C. § 112, ¶ 6. The specification fails to disclose corresponding structure for performing the claimed function of this limitation.

Claims 9, 10, 11, and 12 of the '862 Patent are invalid for indefiniteness to the extent the phrase “a baseband processing module operable to . . . estimate a channel response based upon the preamble sequence” is construed to be governed by 35 U.S.C. § 112, ¶ 6. The specification fails to disclose corresponding structure for performing the claimed function of this limitation.

Claims 9, 10, 11, and 12 of the '862 Patent are invalid for indefiniteness to the extent the phrase “a baseband processing module operable to . . . determine an estimated transmitter beamforming unitary matrix (V) based upon the channel response and a receiver beamforming unitary matrix (U)” is construed to be governed by 35 U.S.C. § 112, ¶ 6. The specification fails to disclose corresponding structure for performing the claimed function of this limitation.

Claims 9, 10, 11, and 12 of the '862 Patent are invalid for indefiniteness to the extent the phrase “a baseband processing module operable to . . . decompose the estimated transmitter beamforming unitary matrix (V) to produce the transmitter beamforming information” is construed to be governed by 35 U.S.C. § 112, ¶ 6. The

specification fails to disclose corresponding structure for performing the claimed function of this limitation.

Claims 9, 10, 11, and 12 of the '862 Patent are invalid for indefiniteness to the extent the phrase “a baseband processing module operable to . . . form a baseband signal employed by the plurality of RF components to wirelessly send the transmitter beamforming information to the transmitting wireless device” is construed to be governed by 35 U.S.C. § 112, ¶ 6. The specification fails to disclose corresponding structure for performing the claimed function of this limitation.

Claims 9, 10, 11, and 12 of the '862 Patent are invalid for failure to comply with the written description and enablement requirements of 35 U.S.C. § 112, ¶ 1 because the patent fails to describe or enable the limitation “a baseband processing module operable to . . . estimate a channel response based upon the preamble sequence.”

Claims 9, 10, 11, and 12 of the '862 Patent are invalid for failure to comply with the written description and enablement requirements of 35 U.S.C. § 112, ¶ 1 because the patent fails to describe or enable the limitation “a baseband processing module operable to . . . determine an estimated transmitter beamforming unitary matrix (V) based upon the channel response and a receiver beamforming unitary matrix (U).”

Claims 9, 10, 11, and 12 of the '862 Patent are invalid for failure to comply with the written description and enablement requirements of 35 U.S.C. § 112, ¶ 1 because the patent fails to describe or enable the limitation “a baseband processing module operable to . . . decompose the estimated transmitter beamforming unitary matrix (V) to produce the transmitter beamforming information.”

Claims 9, 10, 11, and 12 of the '862 Patent are invalid for failure to comply with the definiteness requirement of 35 U.S.C. § 112, ¶ 2 because those skilled in the art cannot determine the scope of any invention with reasonable certainty with respect to the limitation “a baseband processing module operable to . . . estimate a channel response based upon the preamble sequence.”

Claims 9, 10, 11, and 12 of the '862 Patent are invalid for failure to comply with the definiteness requirement of 35 U.S.C. § 112, ¶ 2 because those skilled in the art cannot determine the scope of any invention with reasonable certainty with respect to the limitation “a baseband processing module operable to . . . determine an estimated transmitter beamforming unitary matrix (V) based upon the channel response and a receiver beamforming unitary matrix (U).”

Claims 9, 10, 11, and 12 of the '862 Patent are invalid for failure to comply with the definiteness requirement of 35 U.S.C. § 112, ¶ 2 because those skilled in the art cannot determine the scope of any invention with reasonable certainty with respect to the limitation “a baseband processing module operable to . . . decompose the estimated transmitter beamforming unitary matrix (V) to produce the transmitter beamforming information.”

Claims 9, 10, 11, and 12 of the '862 Patent are invalid for failure to comply with the definiteness requirement of 35 U.S.C. § 112, ¶ 2 because the phrase “the transmitting wireless device” lacks an antecedent basis.

E. 112 Issues for the '450 Patent

Claims 2, 3, 11, 12, and 13 of the '450 Patent are invalid for failure to comply with the definiteness requirement of 35 U.S.C. § 112, ¶ 2 because those skilled in the art cannot determine the scope of the invention with reasonable certainty in view of the limitation “coefficients derived from performing a singular value matrix decomposition (SVD) on said received signals.”

Claims 2, 3, 11, 12, and 13 of the '450 Patent are invalid for failure to comply with the written description and enablement requirements of 35 U.S.C. § 112, ¶ 1 because the patent fails to describe or enable the limitation “coefficients derived from performing a singular value matrix decomposition (SVD) on said received signals.”

Claims 11, 12, and 13 of the '450 Patent are invalid for indefiniteness to the extent the phrase “one or more circuits of a mobile terminal that are operable to compute a plurality of channel estimate matrices based on signals received by said

mobile terminal from a base station, via one or more downlink RF channels” is construed to be governed by 35 U.S.C. § 112, ¶ 6. The specification fails to disclose corresponding structure for performing the claimed function of this limitation.

Claims 11, 12, and 13 of the '450 Patent are invalid for failure to comply with the written description and enablement requirements of 35 U.S.C. § 112, ¶ 1 because the patent fails to describe or enable the limitation “one or more circuits of a mobile terminal that are operable to compute a plurality of channel estimate matrices based on signals received by said mobile terminal from a base station, via one or more downlink RF channels.”

Claim 22 of the '450 Patent is invalid for indefiniteness to the extent the phrase “one or more circuits of a mobile terminal that are operable to compute a plurality of channel estimates based on signals received by said mobile terminal from a base station, via one or more downlink RF channels” is construed to be governed by 35 U.S.C. § 112, ¶ 6. The specification fails to disclose corresponding structure for performing the claimed function of this limitation.

Claim 22 of the '450 Patent is invalid for failure to comply with the written description and enablement requirements of 35 U.S.C. § 112, ¶ 1 because the patent fails to describe or enable the limitation “one or more circuits of a mobile terminal that are operable to compute a plurality of channel estimates based on signals received by said mobile terminal from a base station, via one or more downlink RF channels.”

F. 112 Issues for the '156 Patent

Claims 1 and 2 of the '156 Patent are invalid for indefiniteness to the extent the phrase “a module to establish simultaneous communication paths from said multimode cell phone using both said cell phone functionality and said RF communication functionality” is construed to be governed by 35 U.S.C. § 112, ¶ 6. The specification fails to disclose corresponding structure for performing the claimed function of this limitation.

Claims 1 and 2 of the '156 Patent are invalid for failure to comply with the written description and enablement requirements of 35 U.S.C. § 112, ¶ 1 because the patent fails to describe or enable the limitation “a module to establish simultaneous communication paths from said multimode cell phone using both said cell phone functionality and said RF communication functionality.”

Claims 1 and 2 of the '156 Patent are invalid for failure to comply with the definiteness requirement of 35 U.S.C. § 112, ¶ 2 because those skilled in the art cannot determine the scope of the invention with reasonable certainty with respect to the limitation “a module to establish simultaneous communication paths from said multimode cell phone using both said cell phone functionality and said RF communication functionality.”

Claims 1 and 2 of the '156 Patent are invalid for indefiniteness to the extent the phrase “an automatic switch over module, in communication with both said cell phone functionality and said RF communication functionality, operable to switch a communication path established on one of said cell phone functionality and said RF communication functionality, with another communication path later established on the other of said cell phone functionality and said RF communication functionality” is construed to be governed by 35 U.S.C. § 112, ¶ 6. The specification fails to disclose corresponding structure for performing the claimed function of this limitation.

Claims 1 and 2 of the '156 Patent are invalid for failure to comply with the written description and enablement requirements of 35 U.S.C. § 112, ¶ 1 because the patent fails to describe or enable the limitation “an automatic switch over module, in communication with both said cell phone functionality and said RF communication functionality, operable to switch a communication path established on one of said cell phone functionality and said RF communication functionality, with another communication path later established on the other of said cell phone functionality and said RF communication functionality.”

Claims 1 and 2 of the '156 Patent are invalid for failure to comply with the definiteness requirement of 35 U.S.C. § 112, ¶ 2 because those skilled in the art cannot determine the scope of the invention with reasonable certainty with respect to the limitation “an automatic switch over module, in communication with both said cell phone functionality and said RF communication functionality, operable to switch a communication path established on one of said cell phone functionality and said RF communication functionality, with another communication path later established on the other of said cell phone functionality and said RF communication functionality.”

G. 112 Issues for the '432 Patent

1. 112, 2nd Paragraph, Definiteness Issues for the '432 Patent

Claim 9 is an apparatus claim containing functional language (*i.e.*, “An apparatus . . . configured with at least one processor to cause the apparatus to at least: receive a broadcast indication . . . ; construct the uplink connection request message . . .”). Claim 9 is indefinite for combining both apparatus and method claim language. The broadcast indication is not generated by any structure disclosed, but merely received by the apparatus.

Claims 9 and 12 recite “. . . and a different value of the indication *or omission of the indication* directs that the intra-frequency neighbor cell measurements are prioritized over the inter-frequency neighbor cell measurements . . .” Omission of the indication means that the indication was not received, rendering element 9a moot. Therefore, claims 9 and 12 are indefinite.

H. 112 Issues for the '435 Patent

1. 112, 1st paragraph, Written Description Issues for the '435 Patent

Claim 1 recites “a network adjusted transmit power level as a function of a position to a communications tower.” The specification only uses the term “position” when the specification is summarizing the claims. Otherwise the specification states that “[t]he network adjusted transmit power level is based on a transmit signal strength of a communications path between the communications tower 110 and the portable cell

phone 120.” Therefore, claim 1 is invalid for lack of written description under 35 U.S.C. § 112, first paragraph inasmuch as it recites “a position to a communications tower” without describing such a position.

Claim 3 recites that “proximity transmit power level is limited to a predetermined maximum level.” The only example given of a maximum power level in the specification is of 1 Watt. There is no discussion of a maximum power level being predetermined. Therefore, claim 3 is invalid for lack of written description under 35 U.S.C. § 112, first paragraph inasmuch as it recites “predetermined maximum level” without describing a predetermined maximum level.

Claim 6 recites that “said location sensing subsystem or said power governing subsystem is embodied in an integrated circuit.” Only the “LSS 220” is discussed in the specification explicitly as being “embodied in an integrated circuit.” ’435 Patent at col. 4:47-49. This is the only mention of integrated circuit in the specification. Therefore, claim 6 is invalid for lack of written description under 35 U.S.C. § 112, first paragraph inasmuch as it recites “said location sensing subsystem or said power governing subsystem is embodied in an integrated circuit” without describing such embodiments.

Under at least the claim interpretations upon which Plaintiff apparently relies for its infringement assertions, the asserted claims would be invalid for failure to satisfy the written description requirement because they would be drawn to subject matter that exceeds or otherwise differs from that which one of ordinary skill in the art would understand the named inventors to have had in their possession based on the written description. Accordingly, to the extent the claims are broadly interpreted to support Plaintiff’s infringement theories, the asserted claims are invalid for lack of written description.

2. 112, 2nd paragraph, Definiteness Issues for the ’435 Patent

Claim 1 recites “a network adjusted transmit power level as a function of a position to a communications tower.” However, the specification only uses the

“position” phrasing when summarizing the claims. Otherwise the specification states that “[t]he network adjusted transmit power level is based on a transmit signal strength of a communications path between the communications tower 110 and the portable cell phone 120.” No “position” is disclosed. Therefore, claim 1 is indefinite under 35 U.S.C. § 112, second paragraph, inasmuch as it recites “position” without defining such a position.

Claim 1 recites “a proximity regulation system, including: a location sensing subsystem that determines a location of said portable cell phone proximate a user.” “Proximate” is used multiple times in the specification, but not defined. Without a specified definition, the relative term “proximate” is indefinite. Therefore, claim 1 is also indefinite under 35 U.S.C. § 112, second paragraph for reciting “proximate” without proper definition.

Claim 8 recites “said location sensing subsystem determines said location by employing a sensor selected from the group consisting of: a designated sensor, a contact sensor, a belt clip sensor, and a cradle sensor.” “Designated sensor” is used several times in the specification, but not defined. Furthermore, “designated sensor” is described as being “a contact sensor” in one embodiment. Neither the definition nor scope of “designated sensor” is defined. Therefore, claim 8 is definite under 35 U.S.C. § 112, second paragraph for reciting “designated sensor” without proper definition.

3. 112, 4th paragraph, Dependency Issues for the '435 Patent

Claim 2 recites “The portable cell phone as recited in claim 1 wherein said location sensing subsystem determines said location with respect to a portion of a body of said user.” The specification mostly discusses a user generally, and also provides the example of a user’s head (‘435 Patent col. 4:7-9, 4:52-5:12, also mentioning ear and hand), as well as “different parts of the user’s body” (‘435 Patent col. 7:16-19). However, claim 2 is not properly a dependent claim of independent claim 1, since detection of a body would necessarily be to “a portion of a body.” Therefore, claim 2

fails to meet the requirements of 35 U.S.C. § 112, fourth paragraph, by failing to further limit independent claim 1.

V. DOCUMENT PRODUCTION

Pursuant to Patent L.R. 3.4(a), Defendants will produce, make available for inspection and copying, or identify source code, specifications, schematics, flow charts, artwork, formulas, or other documentation sufficient to show the operation of any specifically identified aspects or elements of an Accused Instrumentality identified by Plaintiff in its Patent L.R. 3.1(c) chart to the extent such information is in Defendants' possession, custody or control.

Pursuant to Patent L.R. 3.4(b), Defendants are producing or making available for inspection and copying copies of each item of prior art identified pursuant to Patent L.R. 3.3(a) which does not appear in the file history of the Asserted Patents. Defendants reserve the right to identify and produce additional documents pursuant to the Patent Rules and the orders of the Court.

Dated: February 25, 2019

By: /s/ James Young Hurt

John P. Schnurer, Bar No. 185725
Joseph P. Reid, Bar No. 211082
Thomas N. Millikan, Bar No. 234430
Yun Louise Lu, Bar No. 253114
James Young Hurt, Bar No. 312390
PERKINS COIE LLP

Attorneys for Defendants COOLPAD
TECHNOLOGIES, INC. AND YULONG
COMPUTER COMMUNICATIONS

Dated: February 25, 2019

By: /s/ Joanna Fuller

Jason W. Wolff (SBN 215819)
wolff@fr.com
Joanna M. Fuller (SBN 266406)
jfuller@fr.com
FISH & RICHARDSON P.C.
12390 El Camino Real
San Diego, CA 92130
Telephone: (858) 678-5070
Facsimile: (858) 678-5099

Attorneys for Defendants HUAWEI DEVICE
(DONGGUAN) CO., LTD, HUAWEI DEVICE
(SHENZHEN) CO., LTD., and HUAWEI
DEVICE USA, INC.

Dated: February 25, 2019

By: /s/ Marc. S. Blackman

M. Andrew Woodmansee, SBN 201780
mawoodmansee@jonesday.com
Jones Day

ZTE (TX) INC.

Exhibit A1

**Exhibit #A1 – Fukiharu 598
to Defendants’ Preliminary Invalidity Contentions**

**Invalidity Chart for U.S. Patent No. 7,319,889
Japanese Unexamined Patent Application Publication No. 2000-106598 (“Fukiharu 598”)**

Japanese Unexamined Patent Application Publication No. 2000-106598 to Fukiharu (“Fukiharu 598”) was published on April 11, 2000. Fukiharu 598 is prior art to the ’889 Patent under at least pre-AIA §§ 102(a), 102(b), and 102(c). Fukiharu 598 anticipates or renders obvious, alone or in combination with other prior art references, each of the Asserted Claims of the ’889 Patent as described in the chart below and in the main invalidity contentions document to which this chart is annexed.

It would have been obvious under 35 U.S.C. § 103 to a person having ordinary skill in the art at the time of the alleged invention to combine the teachings of Fukiharu 598 with the following references:

1. Japanese Unexamined Patent Application Publication No. H11-220432 (“Numazawa”). Numazawa qualifies as prior art under at least pre-AIA §§ 102(a), 102(b), and 102(c). Numazawa was published on August 10, 1999.
2. World Intellectual Property Organization Publication No. WO 00/78012 to Sparre (“Sparre”). Sparre qualifies as prior art under at least pre-AIA §§ 102(b) and 102(c). Sparre was filed on June 8, 2000 and published on December 21, 2000.
3. US. Patent Application Publication No. 2004/0225904 A1 to Perez et al. (“Perez”). Perez qualifies as prior art under at least pre-AIA § 102(c). Perez was filed on May 6, 2003 and published on November 11, 2004.
4. U.K. Patent Application No. 2,357,400 to Mantjarvi et al. (“Mantjarvi”). Mantjarvi qualifies as prior art under at least under at least pre-AIA §§ 102(b), 102(c). Mantjarvi was filed on December 17, 1999 and published on June 20, 2001
5. U.S. Patent No. 5,010,566 to Seo (“Seo”). Seo qualifies as prior art under at least pre-AIA 35 U.S.C. §§ 102(a), 102(b), and 102(c). Seo was filed on September 7, 1989 and issued on April 23, 1991.

<u>Asserted Claims</u>	<u>Corresponding Disclosure in the Prior Art Reference(s)</u>
[Claim 1 – Preamble] 1. A mobile station, comprising:	<p>Fukiharu 598 discloses a mobile station.</p> <p>For example:</p> <p>“Mobile telephone with Lighting Device, and Method for Control Said Lighting Device.” Fukiharu 598 at Title of the Invention.</p>

“However, mobile telephones assume mobility, and thus the use batteries, or lightweight batteries, to supply power, and thus the fact is that a method is used wherein the circuit operation also consumes as little electric power as possible. However, most of the various types of commercially available mobile telephones today have arrived at a point wherein mobile telephones have been developed that are equipped with, in addition to the traditional voice communication functions of telephones, multi-functionality equipped with so-called liquid crystal display devices, enabling, for example, reception and transmission of text data, and, additionally, are equipped with lighting devices (backlights) in the liquid crystal display devices and keypad portions, because at night, or in a state wherein the lighting is poor, liquid crystal display devices or keypad portions would be difficult to read and to operate.” Fukiharu 598 at ¶ 0003.

“FIG. 1 is an external view of a mobile telephone with a touch sensor, depicting an embodiment according to the present invention” Fukiharu 598 at ¶ 0011.

“

[FIG. 1]

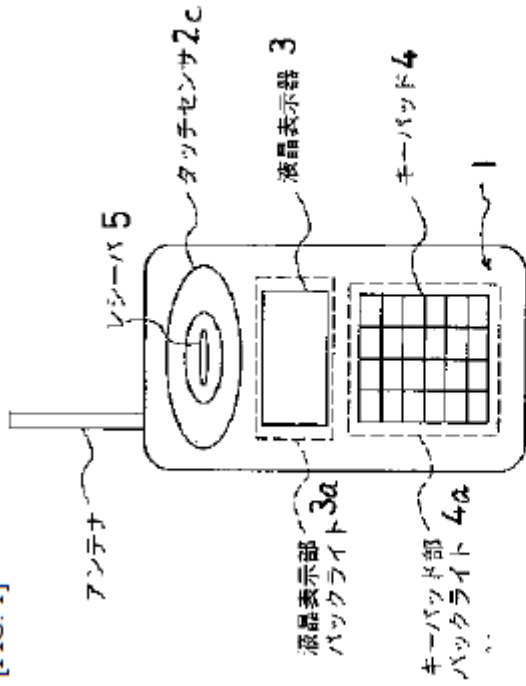

タッチセンサ付き携帯電話機の外観図

[UPPER LEFT] Antenna

5: Receiver

2c: Touch Sensor

3: Liquid Crystal Display Device

4: Keypad

4a: Keypad Portion Backlight

3a: Liquid Crystal Display Portion Backlight

[BOTTOM] Exterior View of Mobile Telephone with

Touch Sensor

”

Fukiharu 598 at Fig. 1.

“In the figures, 1 is a mobile telephone, where, in this mobile telephone 1 a lighting device (backlight) 3a of a liquid crystal display device 3 that is controlled by lighting controlling means 2 that are built into the interior of this mobile telephone 1, and a lighting device (backlight) 4a of a keypad 4, are provided, where data, such as text or symbols, that is displayed, or received, on the liquid crystal display device 3 and

	<p>the keypad portion 4 can be read clearly through the lighting from both of these lighting devices (backlights) 3a and 4a.” Fukiharu 598 at ¶ 0012.</p> <p>“The present invention, through the use of a structure as described above, enables a reduction in the consumption of battery power, through enabling the lighting devices to be turned OFF when the ear is caused to contact the receiver portion in order to hear the receiver sound during voice communications of a mobile telephone when the lighting devices (backlights) for a liquid crystal display device and keypad portion of a mobile telephone are lit, such as that night.” Fukiharu 598 at ¶ 0018.</p> <p>“A mobile telephone with a lighting device, equipped with a lighting device (backlight) on a liquid crystal display device and/or a keypad portion, comprising: lighting controlling means made from a controlling portion, a lighting device ON/OFF circuit portion, and a touch sensor, wherein: the lighting device (backlight) can be turned ON and OFF by the lighting controlling means.” Fukiharu 598 at Claim 1.</p>
<p>[1a] a display;</p>	<p>Fukiharu 598 discloses a display.</p> <p>For example:</p> <p>“The present invention relates to a lighting device controlling method for a mobile telephone that is light weight and has good portability, and that achieves a reduction in the consumption of electric power through controlling, through a touch sensor that is provided on a receiver portion section, the activation of a lighting device (backlight) for a liquid crystal display device or keypad portion that is equipped in the mobile telephone.” Fukiharu 598 at ¶ 0001.</p> <p>“However, mobile telephones assume mobility, and thus the use batteries, or lightweight batteries, to supply power, and thus the fact is that a method is used wherein the circuit operation also consumes as little electric power as possible. However, most of the various types of commercially available mobile telephones today have arrived at a point wherein mobile telephones have been developed that are equipped with, in addition to the traditional voice communication functions of</p>

telephones, multi-functionality equipped with so-called liquid crystal display devices, enabling, for example, reception and transmission of text data, and, additionally, are equipped with lighting devices (backlights) in the liquid crystal display devices and keypad portions, because at night, or in a state wherein the lighting is poor, liquid crystal display devices or keypad portions would be difficult to read and to operate.” Fukiharu 598 at ¶ 0003.

“In the figures, 1 is a mobile telephone, where, in this mobile telephone 1 a lighting device (backlight) 3a of a liquid crystal display device 3 that is controlled by lighting controlling means 2 that are built into the interior of this mobile telephone 1, and a lighting device (backlight) 4a of a keypad portion 4, are provided, where data, such as text or symbols, that is displayed, or received, on the liquid crystal display device 3 and the keypad portion 4 can be read clearly through the lighting from both of these lighting devices (backlights) 3a and 4a.” Fukiharu 598 at ¶ 0012.

“

[FIG. 1]

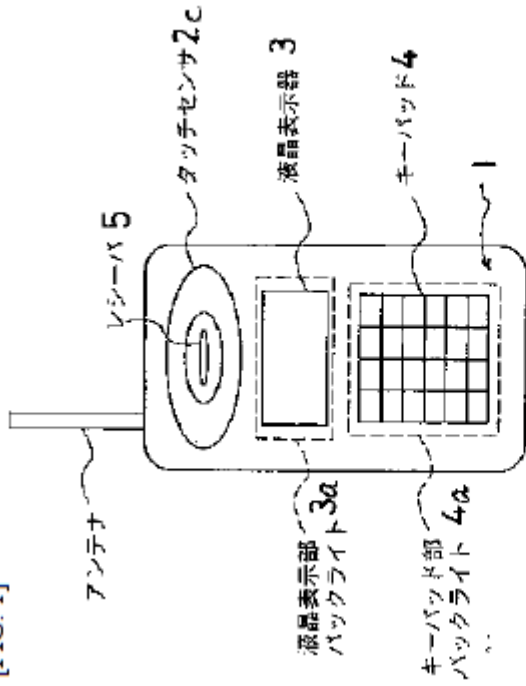

タッチセンサ付き携帯電話機の外観図

[UPPER LEFT] Antenna

5: Receiver

2c: Touch Sensor

3: Liquid Crystal Display Device

4: Keypad

4a: Keypad Portion Backlight

3a: Liquid Crystal Display Portion Backlight

[BOTTOM] Exterior View of Mobile Telephone with Touch Sensor

”

Fukiharu 598 at Fig. 1.

“In the figures, 1 is a mobile telephone, where, in this mobile telephone 1 a lighting device (backlight) 3a of a liquid crystal display device 3 that is controlled by lighting controlling means 2 that are built into the interior of this mobile telephone 1, and a lighting device (backlight) 4a of a keypad portion 4, are provided, where data, such as

text or symbols, that is displayed, or received, on the liquid crystal display device 3 and the keypad portion 4 can be read clearly through the lighting from both of these lighting devices (backlights) 3a and 4a.” Fukiharu 598 at ¶ 0012.

“

[FIG. 2]

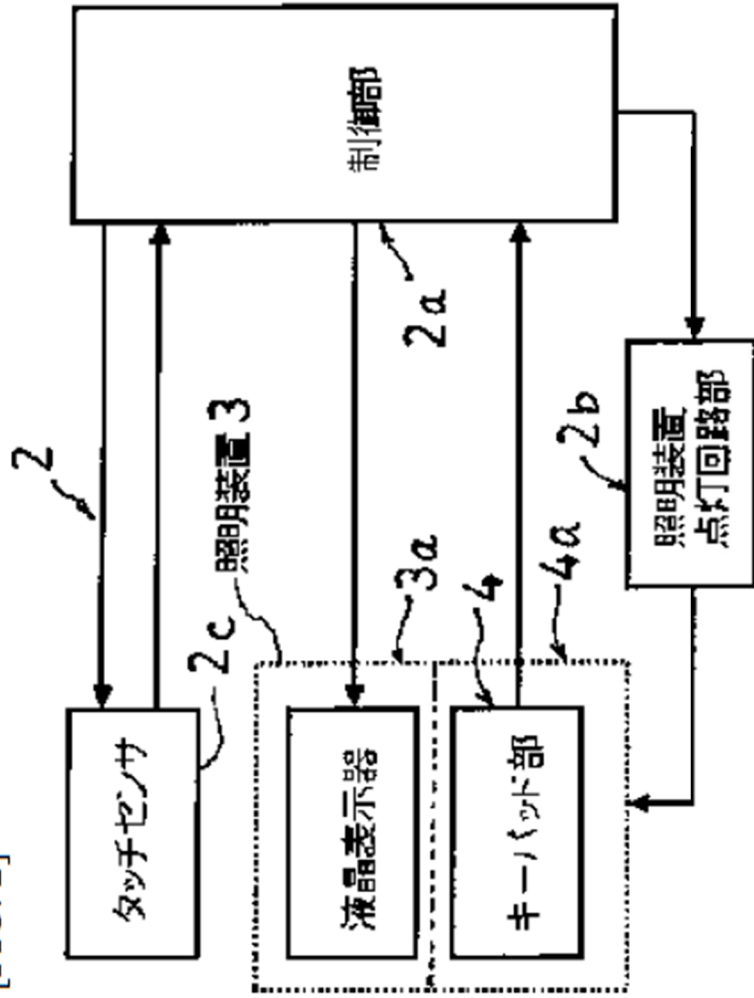

2c: Touch Sensor

3: Lighting Device

3a: Liquid Crystal Display Device

4: Keypad Portion

2a: Controlling Portion

2b: Lighting Device ON/OFF Circuit Portion

Fukiharu 598 at Fig. 2.

	<p>“A mobile telephone with a lighting device, equipped with a lighting device (backlight) on a liquid crystal display device and/or a keypad portion, comprising: lighting controlling means made from a controlling portion, a lighting device ON/OFF circuit portion, and a touch sensor, wherein: the lighting device (backlight) can be turned ON and OFF by the lighting controlling means.” Fukiharu 598 at Claim 1.</p>
<p>[1b] a proximity sensor adapted to generate a signal indicative of proximity of an external object; and</p>	<p>Fukiharu 598 discloses a proximity sensor adapted to generate a signal indicative of proximity of an external object.</p> <p>For example:</p> <p>“The object of the present invention is to provide a mobile telephone with a lighting device, and a method for controlling said lighting device, with improved portability through reducing the weight and volume of the battery, and to enable a thorough increase in talk time and standby time, through controlling, through a touch sensor that is provided on a receiver portion surface of the mobile telephone, operation of a lighting device (backlight) of a liquid crystal display device and/or a keypad portion.” Fukiharu 598 at Abstract.</p> <p>“The present invention relates to a lighting device controlling method for a mobile telephone that is light weight and has good portability, and that achieves a reduction in the consumption of electric power through controlling, through a touch sensor that is provided on a receiver portion section, the activation of a lighting device (backlight) for a liquid crystal display device or keypad portion that is equipped in the mobile telephone.” Fukiharu 598 at ¶ 0001.</p> <p>“The present invention is to solve the problem set forth above, and the object thereof is to provide a lighting device controlling method for a mobile telephone with improved portability through reducing the weight and volume of the battery, and to</p>

enable a thorough increase in talk time and standby time, through controlling, through a touch sensor that is provided on a receiver portion surface of the mobile telephone, operation of a lighting device (backlight) of a liquid crystal display device and/or a key pad portion.” Fukiharu 598 at ¶ 0006.

“Second, a touch sensor that structures the lighting controlling means is activated by the touch sensor contacting a portion of the human body, such as an ear, when listening to the receiver portion. Third, the touch sensor is disposed on the periphery of the receiver of the mobile telephone. Fourth, ON/OFF of the lighting device (backlight) is controlled through a signal that is sent from the controlling portion through a lighting device ON/OFF circuit portion.” Fukiharu 598 at ¶ 0008.

“If in the voice communication mode, a touch sensor 2c is placed into an operating state by a signal from the controlling portion 2a, and constantly outputs a detection output to the controlling portion 2a. If the touch sensor 2c contacts a portion of the human body, such as an ear, a lighting-OFF signal is outputted to the lighting device ON/OFF circuit portion 2b from the controlling portion 2a through the ON output of the touch sensor 2c, and the power supplies to both the lighting device (backlight) 3a and the lighting device (backlight) 4a go to the OFF state, and this lighting-OFF state is maintained until the touch sensor 2c goes into a non-contact state.” Fukiharu 598 at ¶ 0015.

“FIG. 1 is an external view of a mobile telephone with a touch sensor, depicting an embodiment according to the present invention; . . .” Fukiharu 598 at ¶ 0011.

“

[FIG. 1]

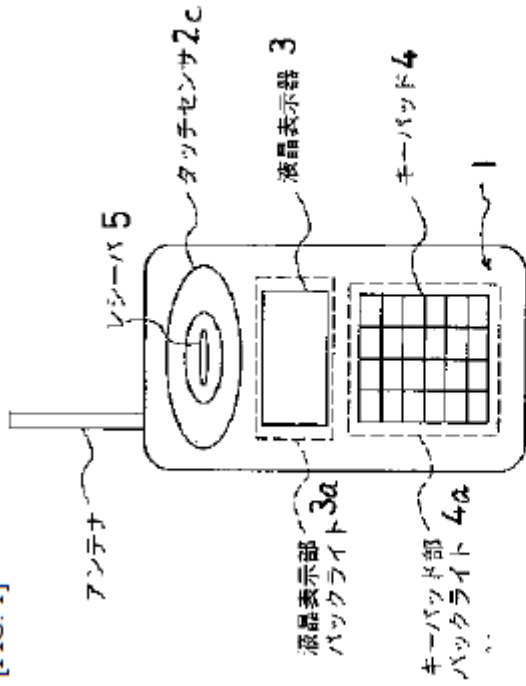

タッチセンサ付き携帯電話機の外観図

[UPPER LEFT] Antenna

5: Receiver

2c: Touch Sensor

3: Liquid Crystal Display Device

4: Keypad

4a: Keypad Portion Backlight

3a: Liquid Crystal Display Portion Backlight

[BOTTOM] Exterior View of Mobile Telephone with Touch Sensor

”

Fukiharu 598 at Fig. 1.

“

[FIG. 2]

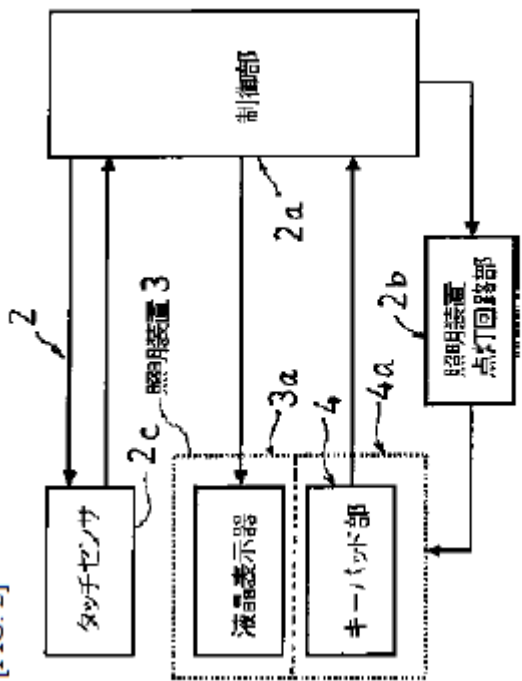

- 2c: Touch Sensor
- 3: Lighting Device
- 3a: Liquid Crystal Display Device
- 4: Keypad Portion
- 2a: Controlling Portion
- 2b: Lighting Device ON/OFF Circuit Portion

Fukiharu 598 at Fig. 2.

“If the touch sensor 2c contacts a portion of the human body, such as an ear, a lighting-OFF signal is outputted to the lighting device ON/OFF circuit portion 2b from the controlling portion 2a through the ON output of the touch sensor 2c, and the power supplies to both the lighting device (backlight) 3a and the lighting device (backlight) 4a go to the OFF state, and this lighting-OFF state is maintained until the touch sensor 2c goes into a non-contact state.” ¶ 0015.

	<p>“A mobile telephone with a lighting device, equipped with a lighting device (backlight) on a liquid crystal display device and/or a keypad portion, comprising: lighting controlling means made from a controlling portion, a lighting device ON/OFF circuit portion, and a touch sensor, wherein: the lighting device (backlight) can be turned ON and OFF by the lighting controlling means.” Fukiharu 598 at Claim 1.</p> <p>“A mobile telephone with a lighting device as set forth in Claim 1, wherein: a touch sensor that structures the lighting controlling means is activated by the touch sensor contacting a portion of the human body, such as an ear, when listening to the receiver portion.” Fukiharu 598 at Claim 2.</p> <p>“A mobile telephone with a lighting device as set forth in Claim 1, wherein: the touch sensor is disposed on the periphery of the receiver of the mobile telephone.” Fukiharu 598 at Claim 3.</p>
<p>[1c] a microprocessor adapted to:</p>	<p>Fukiharu 598 discloses a microprocessor.</p> <p>For example:</p> <p>“First, a mobile telephone device equipped with a lighting device (backlight) on a liquid crystal display device and/or a keypad portion, comprising: lighting controlling means made from a controlling portion, a lighting device ON/OFF circuit portion, and a touch sensor, wherein the lighting device (backlight) can be turned ON and OFF by the lighting controlling means.” Fukiharu 598 at ¶ 0007.</p>

“Fourth, ON/OFF of the lighting device (backlight) is controlled through a signal that is sent from the controlling portion through a lighting device ON/OFF circuit portion.” Fukiharu 598 at ¶ 0008.

“Fifth, a power supply for a mobile telephone is turned ON through pressing of a power supply button of a keypad portion, and, through pressing of a lighting device switch (SW) of a keypad portion, a lighting-ON signal is outputted to a lighting device ON/OFF circuit portion from a controlling portion, to cause the lighting device (backlight) to light, where if not in a voice communication mode, a lighting-ON state is maintained, but if in a voice communication mode, a touch sensor is placed into an operating state by a signal from a controlling portion, and a normal detection output is outputted to the controlling portion and, in addition, if a portion of a human body, such as an ear, makes contact with the touch sensor, a lighting-OFF signal is outputted to the lighting device ON/OFF circuit portion from the controlling portion through an ON output from the touch sensor, to cause the power supply of the lighting device (backlight) to go into the OFF state, and the lighting-OFF state is maintained until the touch sensor is no longer contacted.” Fukiharu 598 at ¶ 0009.

“In the figures, 1 is a mobile telephone, where, in this mobile telephone 1 a lighting device (backlight) 3a of a liquid crystal display device 3 that is controlled by lighting controlling means 2 that are built into the interior of this mobile telephone 1, and a lighting device (backlight) 4a of a keypad portion 4, are provided, where data, such as text or symbols, that is displayed, or received, on the liquid crystal display device 3 and the keypad portion 4 can be read clearly through the lighting from both of these lighting devices (backlights) 3a and 4a.” Fukiharu 598 at ¶ 0012.

“Moreover, the lighting controlling means 2, as with the example depicted in FIG. 2, is structured from a controlling portion 2a, a lighting device ON/OFF circuit portion 2b,

a touch sensor 2c, a lighting device (backlight) 3a of a liquid crystal display device 3, and a lighting device (backlight) 4a of a keypad portion 4.” Fukiharu 598 at ¶ 0013.

“

[FIG. 2]

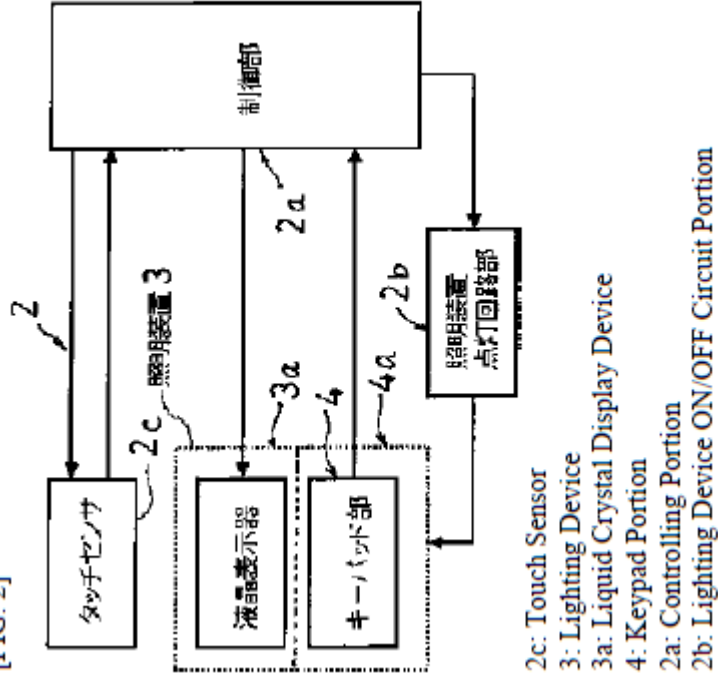

- 2c: Touch Sensor
- 3: Lighting Device
- 3a: Liquid Crystal Display Device
- 4: Keypad Portion
- 2a: Controlling Portion
- 2b: Lighting Device ON/OFF Circuit Portion

”

Fukiharu 598 at Fig. 2.

“Moreover, the configuration is such that the ON/OFF control of the two, the lighting device (backlight) 3a and the lighting device (backlight) 4a, described above, is

controlled through a signal sent from the controlling portion 2a through a lighting device ON/OFF circuit portion 2b. The control method according to the present invention will be explained below, based on the configuration described above. First, the power supply of the mobile telephone 1 is turned ON through pressing of a power supply button of the keypad portion 4. Through a user pressing a lighting switch (SW) of the keypad portion 4, a lighting-ON signal is outputted from the controlling portion 2a to the lighting device ON/OFF circuit portion 2b, causing the lighting device (backlight) 3a and the lighting device (backlight) 4a to become illuminated.” Fukiharu 598 at ¶ 0014.

“If in the voice communication mode, a touch sensor 2c is placed into an operating state by a signal from the controlling portion 2a, and constantly outputs a detection output to the controlling portion 2a. If the touch sensor 2c contacts a portion of the human body, such as an ear, a lighting-OFF signal is outputted to the lighting device ON/OFF circuit portion 2b from the controlling portion 2a through the ON output of the touch sensor 2c, and the power supplies to both the lighting device (backlight) 3a and the lighting device (backlight) 4a go to the OFF state, and this lighting-OFF state is maintained until the touch sensor 2c goes into a non-contact state. Moreover, when the touch sensor 2c goes from a contact state to a non-contact state, a lighting-ON signal is outputted from the controlling portion 2a to the lighting device ON/OFF circuit portion 2b through the OFF output from the touch sensor 2c, and both the lighting device (backlight) 3a and the lighting device (backlight) 4a go into the ON state, and the lighting-ON state is maintained.” ¶ 0015.

“A mobile telephone with a lighting device, equipped with a lighting device (backlight) on a liquid crystal display device and/or a keypad portion, comprising: lighting controlling means made from a controlling portion, a lighting device ON/OFF circuit portion, and a touch sensor, wherein: the lighting device (backlight) can be turned ON and OFF by the lighting controlling means.” Fukiharu 598 at Claim 1.

“A mobile telephone with a lighting device as set forth in Claim 1, configured so that: ON/OFF of the lighting device (backlight) is controlled through a signal that is sent from the controlling portion through a lighting device ON/OFF circuit portion.” Fukiharu 598 at Claim 4.

To the extent Fukiharu 598 is deemed to not expressly disclose a “microprocessor adapted to,” Fukiharu 598 inherently discloses this limitation. Fukiharu 598 discloses a mobile telephone with a controlling means 2, controlling portion 2a, and lighting device ON/OFF circuit portion 2b. Microprocessors (such as the ARM7TDMI) were widely implemented in mobile stations at the time of the alleged invention as a control means. *See, e.g.,* S. Segars, “The ARM9 family-high performance microprocessors for embedded applications”, Proc. ICCD, pp. 230-235, 1998-Oct. A person of ordinary skill in the art at the time of the alleged invention would therefore understand Fukiharu 598 to necessarily disclose a “microprocessor adapted to.”

To the extent Fukiharu 598 is deemed to not expressly or inherently disclose “a microprocessor,” Fukiharu 598 renders it obvious to one of skill in the art to use “a microprocessor.” A person of ordinary skill in the art at the time of the alleged invention would understand that the functionality of controlling means 2, controlling portion 2a, and/or lighting device ON/OFF circuit portion 2b could be implemented using a microprocessor such as the ARM7TDMI. *See, e.g.,* S. Segars, “The ARM9 family-high performance microprocessors for embedded applications”, Proc. ICCD, pp. 230-235, 1998-Oct.. Doing so would be a design choice driven by a number of different reasons, including that it would support Fukiharu 598’s ability to conserve battery power in mobile stations, and doing so would be within the knowledge and ability of a person of ordinary skill in the art at the time of the alleged invention. The use of a microprocessor would constitute, at least, combining prior art elements according to known methods to yield predictable results, a simple substitution of one known element for another to obtain predictable results, the use of a known technique

to improve similar devices in the same way, the application of a known technique to a known device ready for improvement to yield a predictable result, and obvious to try.

To the extent Fukiharu 598 is deemed to not expressly or inherently disclose “a microprocessor,” it would be obvious to combine the disclosure of Fukiharu 598 with those of Numazawa as described in the Numazawa claim chart, which is incorporated herein in its entirety by reference. Fukiharu 598 and Numazawa are both directed to conserving battery power in mobile stations generally and more particularly at conserving battery power in mobile stations by using sensors to detect when the user of the mobile station is in a call and unlikely to be looking at the display (as when, for example, the proximity sensor detects the user’s ear by the mobile station) and to power off the display of mobile stations at such times. Fukiharu 598 at ¶ 0018 (“The present invention, through the use of a structure as described above, enables a reduction in the consumption of battery power, through enabling the lighting devices to be turned OFF when the ear is caused to contact the receiver portion in order to hear the receiver sound during voice communications of a mobile telephone when the lighting devices (backlights) for a liquid crystal display device and keypad portion of a mobile telephone are lit, such as that night.”); Numazawa at ¶ Abstract (“To achieve reduced power consumption through stopping operation of unnecessary functions during use of a wireless terminal. A CPU 2 identifies start of a call state through a signal from a signal processing portion 3 for controlling communication with a base station, and identifies, through an output signal from detecting means 6, whether or not a user ear is in contact with a terminal. Upon identification of contact of the ear to the terminal, controlling means 8 are caused to stop the supply of electric power, from a power supply 7, to displaying means 9 for providing information to a user, and lighting means 10, such as a black light.”), ¶ 0005-0007 (“In the present invention, control is such that, upon determination that the wireless terminal is in a call, operation of functions believe be unnecessary, due to the user of the terminal being in a call, is stopped, and upon termination of the call, operation of the stopped functions is restarted. Additionally, because it is envisioned that there will also be cases where, even during a call, the face of the user may be separated from the receiver of the terminal, control is performed so as to enable restarting of the operations of the functions that

had been stopped as unnecessary, through detecting whether or not the user of the terminal has the receiver in contact with an ear. The achievement of reduced power consumption through stopping operation of functions that become unnecessary in use of the terminal, as described above, can be anticipated to have the effect of extending the life of the power supply, such as a battery.’). A person of ordinary skill in the art at the time of the alleged invention would be motivated to modify Fukiharu 598 to use “a microprocessor” as disclosed in Numazawa for a number of different reasons, including that it would support Fukiharu 598’s ability to conserve battery power in mobile stations, and doing so would be within the knowledge and ability of a person of ordinary skill in the art at the time of the alleged invention. As a specific example, Numazawa discloses the use of a CPU to send a signal to a controlling means in order for the controlling means to carry out certain functions such as shutting power off to the display of the mobile station. *See* Numazawa at ¶ 0021 (“Following this, in Step S4, the CPU 2 outputs, to the controlling means 8, a signal for stopping the displaying means 9 and the lighting means 10. Through this, the controlling means 8 stop the supply of power from the power supply 7 to the displaying means 9 and the lighting means 10, and the displaying means 9 and lighting means 10 stop operating.’). A person of ordinary skill in the art at the time of the alleged invention would be motivated to improve Fukiharu 598’s “controlling means 2” (and/or controlling portion 2a, and lighting device ON/OFF circuit portion 2b) in the same way by employing the CPU disclosed in Numazawa. The combination would constitute, at least, combining prior art elements according to known methods to yield predictable results, a simple substitution of one known element for another to obtain predictable results, the use of a known technique to improve similar devices in the same way, the application of a known technique to a known device ready for improvement to yield a predictable result, and obvious to try.

To the extent Fukiharu 598 is deemed to not expressly or inherently disclose “a microprocessor,” it would be obvious to combine the disclosure of Fukiharu 598 with those of Sparre as described in the Sparre claim chart, which is incorporated herein in its entirety by reference. Fukiharu 598 and Sparre are both directed to conserving battery power in mobile stations generally and more particularly at conserving battery

power in mobile stations by using sensors to detect when the user of the mobile station is in a call and unlikely to be looking at the display (as when, for example, the proximity sensor detects the user's ear by the mobile station) and to power off the display of mobile stations at such times. Fukiharu 598 at ¶ 0018 (“The present invention, through the use of a structure as described above, enables a reduction in the consumption of battery power, through enabling the lighting devices to be turned OFF when the ear is caused to contact the receiver portion in order to hear the receiver sound during voice communications of a mobile telephone when the lighting devices (backlights) for a liquid crystal display device and keypad portion of a mobile telephone are lit, such as that night.”); Sparre at 6 (“The purpose of the present invention is to propose an improved solution to the problem of preserving electric power in a portable electric apparatus having a liquid crystal display. In particular, the invention aims at achieving such power preservation at a lower cost and with improved accuracy, as compared to the prior art solutions. According to the invention, the portable electric apparatus is provided with a proximity detector, which is arranged to detect when an external object is very close to a specific portion of the apparatus (for instance less than 3 cm from the display). The external object may be the user's ear (when the telephone is held in a normal position for conversation), or the interior walls of a pocket or bag, in which the telephone has been placed by the user. In all circumstances, the presence of such an external object indicates that the apparatus is not in a position, where it is useful to keep the display turned on, since the user is physically prevented from visual access to the display. Therefore, when the proximity detector has detected the presence of the external object, the display may be powered off or present less visual information.”). A person of ordinary skill in the art at the time of the alleged invention would be motivated to modify Fukiharu 598 to use “a microprocessor” as disclosed in Sparre for a number of different reasons, including that it would support Fukiharu 598's ability to conserve battery power in mobile stations, and doing so would be within the knowledge and ability of a person of ordinary skill in the art at the time of the alleged invention. As a specific example, Sparre discloses the use of a controller to carry out certain functions in a mobile station such as turning off the display. *See* Sparre at 11 (“... the controller 30 is arranged to bring the liquid crystal display 6 into its inactive state ...”). Sparre further specifically teaches that “[t]he controller 30 may be any microprocessor, central processing unit (CPU) or other piece of electronic logic circuitry already used in the telephone 1 for performing the various functions thereof

(such as telephone call control, keypad control, display control, or execution of utility programs such as a calculator program, electronic game programs, etc).” Sparre at 10-11. A person of ordinary skill in the art at the time of the alleged invention would therefore understand that Fukiharu 598’s “controlling means 2” (and/or controlling portion 2a, and lighting device ON/OFF circuit portion 2b) could be implemented as a CPU/microprocessor, just like the “controller 30” was disclosed to be implemented in Sparre. The combination would constitute, at least, combining prior art elements according to known methods to yield predictable results, a simple substitution of one known element for another to obtain predictable results, the use of a known technique to improve similar devices in the same way, the application of a known technique to a known device ready for improvement to yield a predictable result, and obvious to try.

To the extent Fukiharu 598 is deemed to not expressly or inherently disclose “a microprocessor,” it would be obvious to combine the disclosure of Fukiharu 598 with those of Perez as described in the Perez claim chart, which is incorporated herein in its entirety by reference. Fukiharu 598 and Perez are both directed to conserving battery power in mobile stations generally and more particularly at conserving battery power in mobile stations by using sensors to detect when the user of the mobile station is in a call and unlikely to be looking at the display (as when, for example, the proximity sensor detects the user’s ear by the mobile station) and to power off the display of mobile stations at such times. Fukiharu 598 at ¶ 0018 (“The present invention, through the use of a structure as described above, enables a reduction in the consumption of battery power, through enabling the lighting devices to be turned OFF when the ear is caused to contact the receiver portion in order to hear the receiver sound during voice communications of a mobile telephone when the lighting devices (backlights) for a liquid crystal display device and keypad portion of a mobile telephone are lit, such as that night.”); Perez at ¶ 0013 (“Referring to FIG. 1, a portable communication product 10 such as a cellular phone includes a transceiver radio having a microphone 20, an earpiece 22, a keypad 18 and a display 12 (such as a color display) coupled to the transceiver radio. The portable communication product 10 further includes at least one sensor (24, 26, 28 or 30) and a processor 16. The sensor can be used for detecting a user condition of the portable communication device such as a talk condition when the

user is assumed to be talking on the portable communication device. The processor 16 can be programmed to at least reduce power provided to the display 12 when the sensor detects the talk condition. The processor 16 can also turn off power to the display 12 during a talk condition if desired.”). A person of ordinary skill in the art at the time of the alleged invention would be motivated to modify Fukiharu 598 to use “a microprocessor” as disclosed in Perez for a number of different reasons, including that it would support Fukiahru 598’s ability to conserve battery power in mobile stations, and doing so would be within the knowledge and ability of a person of ordinary skill in the art at the time of the alleged invention. As a specific example, Perez discloses the use of a processor to carry out certain functions such as shutting power off to the display of the mobile station. *See* Perez at ¶ 0021 (“The processor 16 can be programmed to at least reduce power provided to the display 12 when the sensor detects the talk condition. The processor 16 can also turn off power to the display 12 during a talk condition if desired.”). A person of ordinary skill in the art at the time of the alleged invention would be motivated to improve Fukiharu 598’s “controlling means 2” (and/or controlling portion 2a, and lighting device ON/OFF circuit portion 2b) in the same way by employing the processor disclosed in Perez. The combination would constitute, at least, combining prior art elements according to known methods to yield predictable results, a simple substitution of one known element for another to obtain predictable results, the use of a known technique to improve similar devices in the same way, the application of a known technique to a known device ready for improvement to yield a predictable result, and obvious to try.

To the extent Fukiharu 598 is deemed to not expressly or inherently disclose “a microprocessor,” it would be obvious to combine the disclosure of Fukiharu 598 with those of Mantlyarvi as described in the Mantlyarvi claim chart, which is incorporated herein in its entirety by reference. are both directed to conserving battery power in mobile stations generally and more particularly at conserving battery power in mobile stations by using sensors to detect when the user of the mobile station is in a call and unlikely to be looking at the display (as when, for example, the proximity sensor detects the user’s ear by the mobile station) and to power off the display of mobile stations at such times. Fukiharu 598 at ¶ 0018 (“The present invention, through the use of a

structure as described above, enables a reduction in the consumption of battery power, through enabling the lighting devices to be turned OFF when the ear is caused to contact the receiver portion in order to hear the receiver sound during voice communications of a mobile telephone when the lighting devices (backlights) for a liquid crystal display device and keypad portion of a mobile telephone are lit, such as that night.”); Mantjarvi at 9:5-8 (“The station may also be switched between different modes of operation or even on and off based on the output signal received from the detecting means. The lighting of the keypad and/or the display may be controlled based on this information.”). A person of ordinary skill in the art at the time of the alleged invention would be motivated to modify Fukiharu 598 to use “a microprocessor” as disclosed in Mantjarvi for a number of different reasons, including that it would support Fukiharu 598’s ability to conserve battery power in mobile stations, and doing so would be within the knowledge and ability of a person of ordinary skill in the art at the time of the alleged invention. As a specific example, Mantjarvi discloses the use of a processor to carry out certain functions such as shutting power off to the display of the mobile station. *See* Mantjarvi at 6:10-16 (“Figure 1 shows a mobile station in accordance with an embodiment of the present invention. The mobile station 1 comprises a housing or cover portion 11 which protects and encapsulates the various internal components of the mobile station. The internal components are not shown in greater detail, but may typically comprise components such as a processor 12 that is for controlling one or several functions of the mobile station.”). A person of ordinary skill in the art at the time of the alleged invention would be motivated to improve Fukiharu 598’s “controlling means 2” (and/or controlling portion 2a, and lighting device ON/OFF circuit portion 2b) in the same way by employing the processor disclosed in Mantjarvi. The combination would constitute, at least, combining prior art elements according to known methods to yield predictable results, a simple substitution of one known element for another to obtain predictable results, the use of a known technique to improve similar devices in the same way, the application of a known technique to a known device ready for improvement to yield a predictable result, and obvious to try.

[1d] (a) determine whether a telephone call is active;

Fukiharu 598 discloses the microprocessor adapted to determine whether a telephone call is active.

For example:

“Fifth, a power supply for a mobile telephone is turned ON through pressing of a power supply button of a keypad portion, and, through pressing of a lighting device switch (SW) of a keypad portion, a lighting-ON signal is outputted to a lighting device ON/OFF circuit portion from a controlling portion, to cause the lighting device (backlight) to light, where if not in a voice communication mode, a lighting-ON state is maintained, but if in a voice communication mode, a touch sensor is placed into an operating state by a signal from a controlling portion, and a normal detection output is outputted to the controlling portion and, in addition, if a portion of a human body, such as an ear, makes contact with the touch sensor, a lighting-OFF signal is outputted to the lighting device ON/OFF circuit portion from the controlling portion through an ON output from the touch sensor, to cause the power supply of the lighting device (backlight) to go into the OFF state, and the lighting-OFF state is maintained until the touch sensor is no longer contacted.” Fukiharu 598 at ¶ 0009.

“Sixth, when the touch sensor goes from a contact state to a non-contact state, a lighting-ON signal is outputted to the lighting device ON/OFF circuit portion from the controlling portion through an OFF output from the touch sensor, so that the power supply for the lighting device (backlight) will go into the ON state, and the lighting-on state is maintained, and, additionally, when, while the touch sensor is in the non-contact state, a non-voice communication mode is entered from the voice communication mode, the power supply to the touch sensor is cut off, producing a non-operating state, and the lighting-on state is maintained.” Fukiharu 598 at ¶ 0010.

“At this time, the lighting-ON state is maintained if not in the voice communication mode. If in the voice communication mode, a touch sensor 2c is placed into an

operating state by a signal from the controlling portion 2a, and constantly outputs a detection output to the controlling portion 2a.” Fukiharu 598 at ¶ 0015.

“Additionally, when the touch sensor 2c is in the noncontact state, if the state changes from the voice communication mode to other than the voice communication mode, the power supply to the touch sensor 2c is cut off, to produce a non-operating state, and the lighting-ON state is maintained.” Fukiharu 598 at ¶ 0016.

“

[FIG. 3]

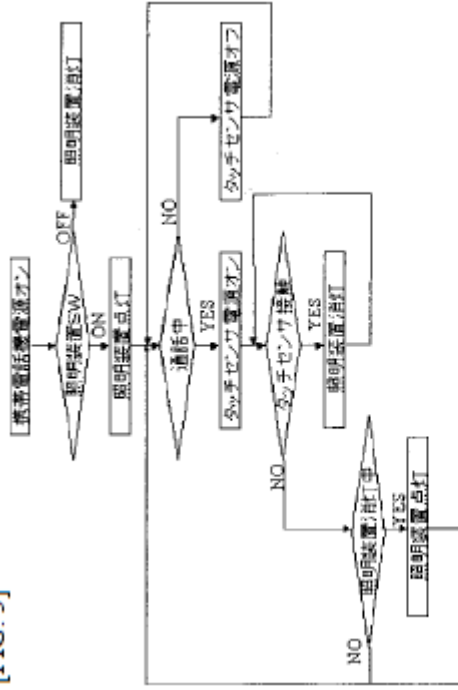

[LOWER LEFT DIAMOND] Lighting device OFF?
 [LOWER LEFT RECTANGLE] Turn lighting device ON.
 [MIDDLE COLUMN, TOP TO BOTTOM]
 Mobile telephone power supply ON
 Lighting device SW?
 Voice communication in process?
 Turn touch sensor power supply ON.
 Touch sensor contacted?
 Turn lighting device OFF.
 [UPPER RIGHT] Turn lighting device OFF.
 [BOTTOM RIGHT] Turn touch sensor power supply OFF. »

Fukiharu 598 at Fig. 3.

“A lighting controlling method for a mobile telephone wherein: the power supply for the mobile telephone is turned ON through pressing of a power supply button of a keypad portion; and through pressing of a lighting device switch (SW) of a keypad portion, a lighting-ON signal is outputted to a lighting device ON/OFF circuit portion

from a controlling portion, to cause the lighting device (backlight) to light, where if not in a voice communication mode, a lighting-ON state is maintained, but if in a voice communication mode, a touch sensor is placed into an operating state by a signal from a controlling portion, and a normal detection output is outputted to the controlling portion and, in addition, if a portion of a human body, such as an ear, makes contact with the touch sensor, a lighting-OFF signal is outputted to the lighting device ON/OFF circuit portion from the controlling portion through an ON output from the touch sensor, to cause the power supply of the lighting device (backlight) to go into the OFF state, and the lighting-OFF state is maintained until the touch sensor is no longer contacted.” Fukiharu 598 at Claim 5.

To the extent Fukiharu 598 is deemed to not expressly disclose the microprocessor adapted to determine whether a telephone call is active, Fukiharu 598 inherently discloses this limitation. In Fukiharu 598, the mobile telephone is able to determine whether it is in voice communication mode. Fukiharu 598 further specifies that the determination of whether the mobile telephone is in voice communication mode is made without use of the touch sensor, as the touch sensor is not placed into an operating state until after the mobile telephone determines that it is in voice communication mode. A person of ordinary skill in the art at the time of the alleged invention would therefore understand that, in order for the mobile phone to determine whether it is in voice communication mode it must necessarily “determine[s] whether a telephone call is active.” Further as noted above for element [1d] and incorporated by reference here, Fukiharu 598 discloses or renders obvious the use of a microprocessor. Therefore, a person of ordinary skill in the art at the time of the alleged invention would understand that necessarily the microprocessor would “determine whether a telephone call is active.”

To the extent Fukiharu 598 is deemed to not expressly or inherently disclose a microprocessor adapted to “determine whether a telephone call is active,” Fukiharu 598 renders it obvious to one of skill in the art at the time of the alleged invention to use a microprocessor adapted to “determine whether a telephone call is active.” In

Fukiharu 598, the mobile telephone is able to determine whether it is in voice communication mode. Fukiharu 598 further specifies that the determination of whether the mobile telephone is in voice communication mode is made without use of the touch sensor, as the touch sensor is not placed into an operating state until after the mobile telephone determines that it is in voice communication mode. It would therefore be obvious to a person of ordinary skill in the art at the time of the alleged invention that Fukiharu 598 could use a microprocessor to determine whether it is in voice communication mode, such that Fukiharu 598 would contain a microprocessor adapted to “determine whether a telephone call is active.”

To the extent Fukiharu 598 is deemed to not expressly or inherently disclose a microprocessor adapted to “determine whether a telephone call is active,” it would be obvious to combine the disclosure of Fukiharu 598 with those of Numazawa as described in the Numazawa claim chart, which is incorporated herein in its entirety by reference. Fukiharu 598 and Numazawa are both directed to conserving battery power in mobile stations generally and more particularly at conserving battery power in mobile stations by using sensors to detect when the user of the mobile station is in a call and unlikely to be looking at the display (as when, for example, the proximity sensor detects the user’s ear by the mobile station) and to power off the display of mobile stations at such times. Fukiharu 598 at ¶ 0018 (“The present invention, through the use of a structure as described above, enables a reduction in the consumption of battery power, through enabling the lighting devices to be turned OFF when the ear is caused to contact the receiver portion in order to hear the receiver sound during voice communications of a mobile telephone when the lighting devices (backlights) for a liquid crystal display device and keypad portion of a mobile telephone are lit, such as that night.”); Numazawa at ¶ Abstract (“To achieve reduced power consumption through stopping operation of unnecessary functions during use of a wireless terminal. A CPU 2 identifies start of a call state through a signal from a signal processing portion 3 for controlling communication with a base station, and identifies, through an output signal from detecting means 6, whether or not a user ear is in contact with a terminal. Upon identification of contact of the ear to the terminal, controlling means 8 are caused to stop the supply of electric power, from a power supply 7, to displaying means

9 for providing information to a user, and lighting means 10, such as a black light.”), ¶ 0005-0007 (“In the present invention, control is such that, upon determination that the wireless terminal is in a call, operation of functions believe be unnecessary, due to the user of the terminal being in a call, is stopped, and upon termination of the call, operation of the stopped functions is restarted. Additionally, because it is envisioned that there will also be cases where, even during a call, the face of the user may be separated from the receiver of the terminal, control is performed so as to enable restarting of the operations of the functions that had been stopped as unnecessary, through detecting whether or not the user of the terminal has the receiver in contact with an ear. The achievement of reduced power consumption through stopping operation of functions that become unnecessary in use of the terminal, as described above, can be anticipated to have the effect of extending the life of the power supply, such as a battery.”). A person of ordinary skill in the art at the time of the alleged invention would therefore be motivated to Fukiharu 598 with Numazawa’s teaching of a microprocessor adapted to “determine whether a telephone call is active,” for a number of different reasons, including that it would support Fukiharu 598’s ability to conserve battery power in mobile stations, and doing so would be within the knowledge and ability of a person of ordinary skill in the art at the time of the alleged invention. As a more specific example, it would be obvious for one of ordinary skill in the art at the time of the alleged invention to use Numazawa’s teaching of “A CPU 2 identifies start of a call state through a signal from a signal processing portion 3 for controlling communication with a base station” to carry out Fukiharu 598’s mobile telephone’s determination that it is in voice communication mode. The combination would constitute, at least, combining prior art elements according to known methods to yield predictable results, a simple substitution of one known element for another to obtain predictable results, the use of a known technique to improve similar devices in the same way, the application of a known technique to a known device ready for improvement to yield a predictable result, and obvious to try.

To the extent Fukiharu 598 is deemed to not expressly or inherently disclose a microprocessor adapted to “determine whether a telephone call is active,” it would be obvious to combine the disclosure of Fukiharu 598 with those of Sparre as described in

the Sparre claim chart, which is incorporated herein in its entirety by reference. Fukiharu 598 and Sparre are both directed to conserving battery power in mobile stations generally and more particularly at conserving battery power in mobile stations by using sensors to detect when the user of the mobile station is in a call and unlikely to be looking at the display (as when, for example, the proximity sensor detects the user's ear by the mobile station) and to power off the display of mobile stations at such times. Fukiharu 598 at ¶ 0018 (“The present invention, through the use of a structure as described above, enables a reduction in the consumption of battery power, through enabling the lighting devices to be turned OFF when the ear is caused to contact the receiver portion in order to hear the receiver sound during voice communications of a mobile telephone when the lighting devices (backlights) for a liquid crystal display device and keypad portion of a mobile telephone are lit, such as that night.”); Sparre at 6 (“The purpose of the present invention is to propose an improved solution to the problem of preserving electric power in a portable electric apparatus having a liquid crystal display. In particular, the invention aims at achieving such power preservation at a lower cost and with improved accuracy, as compared to the prior art solutions. According to the invention, the portable electric apparatus is provided with a proximity detector, which is arranged to detect when an external object is very close to a specific portion of the apparatus (for instance less than 3 cm from the display). The external object may be the user's ear (when the telephone is held in a normal position for conversation), or the interior walls of a pocket or bag, in which the telephone has been placed by the user. In all circumstances, the presence of such an external object indicates that the apparatus is not in a position, where it is useful to keep the display turned on, since the user is physically prevented from visual access to the display. Therefore, when the proximity detector has detected the presence of the external object, the display may be powered off or present less visual information.”). A person of ordinary skill in the art at the time of the alleged invention would therefore be motivated to combine Fukiharu 598 with Sparre's teaching of a microprocessor adapted to “determine whether a telephone call is active,” for a number of different reasons, including that it would support Fukiharu 598's ability to conserve battery power in mobile stations, and doing so would be within the knowledge and ability of a person of ordinary skill in the art at the time of the alleged invention. As a more specific example, Sparre teaches that “the controller 30 has detected that the user has started initiating an outgoing call,” Sparre at 13, and that “[t]he controller 30 may be

any microprocessor, central processing unit (CPU) or other piece of electronic logic circuitry already used in the telephone 1 for performing the various functions thereof' Sparre at 10. It would therefore be obvious to one of ordinary skill in the art at the time of the alleged invention to use the microprocessor disclosed in Sparre to carry out Fukiharu 598's mobile telephone's determination that it is in voice communication mode. The combination would constitute, at least, combining prior art elements according to known methods to yield predictable results, a simple substitution of one known element for another to obtain predictable results, the use of a known technique to improve similar devices in the same way, the application of a known technique to a known device ready for improvement to yield a predictable result, and obvious to try.

To the extent Fukiharu 598 is deemed to not expressly or inherently disclose a microprocessor adapted to "determine whether a telephone call is active," it would be obvious to combine the disclosure of Fukiharu 598 with those of Perez as described in the Perez claim chart, which is incorporated herein in its entirety by reference. Fukiharu 598 and Perez are both directed to conserving battery power in mobile stations generally and more particularly at conserving battery power in mobile stations by using sensors to detect when the user of the mobile station is in a call and unlikely to be looking at the display (as when, for example, the proximity sensor detects the user's ear by the mobile station) and to power off the display of mobile stations at such times. Fukiharu 598 at ¶ 0018 ("The present invention, through the use of a structure as described above, enables a reduction in the consumption of battery power, through enabling the lighting devices to be turned OFF when the ear is caused to contact the receiver portion in order to hear the receiver sound during voice communications of a mobile telephone when the lighting devices (backlights) for a liquid crystal display device and keypad portion of a mobile telephone are lit, such as that night."); Perez at ¶ 0013 ("Referring to FIG. 1, a portable communication product 10 such as a cellular phone includes a transceiver radio having a microphone 20, an earpiece 22, a keypad 18 and a display 12 (such as a color display) coupled to the transceiver radio. The portable communication product 10 further includes at least one sensor (24, 26, 28 or 30) and a processor 16. The sensor can be used for detecting a user condition of the portable communication device such as a talk condition when the user is assumed to be talking

on the portable communication device. The processor 16 can be programmed to at least reduce power provided to the display 12 when the sensor detects the talk condition. The processor 16 can also turn off power to the display 12 during a talk condition if desired.”). A person of ordinary skill in the art at the time of the alleged invention would therefore be motivated to combine Fukiharu 598 with Perez’s teaching of a microprocessor adapted to “determine whether a telephone call is active,” for a number of different reasons, including that it would support Fukiahru 598’s ability to conserve battery power in mobile stations, and doing so would be within the knowledge and ability of a person of ordinary skill in the art at the time of the alleged invention. As a more specific example, Perez teaches that “[a] talk condition, for example, can be sensed by detecting if a predetermined volume of acoustic sound is being received at the microphone 20 or at another sensor such as a proximity sensor 26 indicative of a user talking on the portable communication device” (Perez at ¶ 0015) and that “[t]he processor can be programmed to at least reduce power provided to the display when the sensor detects the talk condition. The processor can also turn off power to the display during a talk condition if desired” (Perez at ¶ 0006). It would therefore be obvious to one of ordinary skill in the art at the time of the alleged invention to use the microprocessor disclosed in Perez to carry out Fukiharu 598’s mobile telephone’s determination that it is in voice communication mode. The combination would constitute, at least, combining prior art elements according to known methods to yield predictable results, a simple substitution of one known element for another to obtain predictable results, the use of a known technique to improve similar devices in the same way, the application of a known technique to a known device ready for improvement to yield a predictable result, and obvious to try.

To the extent Fukiharu 598 is deemed to not expressly or inherently disclose a microprocessor adapted to “determine whether a telephone call is active,” it would be obvious to combine the disclosure of Fukiharu 598 with those of Mantiyarvi as described in the Mantiyarvi claim chart, which is incorporated herein in its entirety by reference. Fukiharu 598 and Mantiyarvi are both directed to conserving battery power in mobile stations generally and more particularly at conserving battery power in mobile stations by using sensors to detect when the user of the mobile station is in a call and

unlikely to be looking at the display (as when, for example, the proximity sensor detects the user's ear by the mobile station) and to power off the display of mobile stations at such times. Fukiharu 598 at ¶ 0018 (“The present invention, through the use of a structure as described above, enables a reduction in the consumption of battery power, through enabling the lighting devices to be turned OFF when the ear is caused to contact the receiver portion in order to hear the receiver sound during voice communications of a mobile telephone when the lighting devices (backlights) for a liquid crystal display device and keypad portion of a mobile telephone are lit, such as that night.”); Mantiyarvi at 9:5-8 (“The station may also be switched between different modes of operation or even on and off based on the output signal received from the detecting means. The lighting of the keypad and/or the display may be controlled based on this information.”). A person of ordinary skill in the art at the time of the alleged invention would therefore be motivated to combine Fukiharu 598 with Mantiyarvi’s teaching of a microprocessor adapted to “determine whether a telephone call is active,” for a number of different reasons, including that it would support Fukiharu 598’s ability to conserve battery power in mobile stations, and doing so would be within the knowledge and ability of a person of ordinary skill in the art at the time of the alleged invention. As a more specific example, Mantiyarvi teaches that “[t]he controller may provide different instructions for the controlled functions depending on the location or the context where the control is provided. For example, during a normal speech call the lighting of the display and/or keyboard may be switched off after a predefined time has lapsed from the activation thereof. However, the lightning will stay on if the connection was established for data communication, such as for a wireless application protocol (WAP) connection or for an Internet connection,” (Mantiyarvi at 14:21-30) and “a processor 12 that is for controlling one or several functions of the mobile station” (Mantiyarvi at 6:15-16.). It would therefore be obvious to one of ordinary skill in the art at the time of the alleged invention to use the microprocessor disclosed in Mantiyarvi to carry out Fukiharu 598’s mobile telephone’s determination that it is in voice communication mode. The combination would constitute, at least, combining prior art elements according to known methods to yield predictable results, a simple substitution of one known element for another to obtain predictable results, the use of a known technique to improve similar devices in the same way, the

	<p>application of a known technique to a known device ready for improvement to yield a predictable result, and obvious to try.</p>
<p>[1e] (b) receive the signal from the proximity sensor; and</p>	<p>Fukiharu 598 discloses the microprocessor adapted to receive the signal from the proximity sensor.</p> <p>For example:</p> <p><i>See</i> discussion of claim element [1b], <i>supra</i>, which is incorporated herein by reference.</p> <p>“The present invention is to solve the problem set forth above, and the object thereof is to provide a lighting device controlling method for a mobile telephone with improved portability through reducing the weight and volume of the battery, and to enable a thorough increase in talk time and standby time, through controlling, through a touch sensor that is provided on a receiver portion surface of the mobile telephone, operation of a lighting device (backlight) of a liquid crystal display device and/or a key pad portion.” Fukiharu 598 at ¶ 0006.</p> <p>“Second, a touch sensor that structures the lighting controlling means is activated by the touch sensor contacting a portion of the human body, such as an ear, when listening to the receiver portion. Third, the touch sensor is disposed on the periphery of the receiver of the mobile telephone. Fourth, ON/OFF of the lighting device (backlight) is controlled through a signal that is sent from the controlling portion through a lighting device ON/OFF circuit portion.” Fukiharu 598 at ¶ 0008.</p> <p>“Fifth, a power supply for a mobile telephone is turned ON through pressing of a power supply button of a keypad portion, and, through pressing of a lighting device switch (SW) of a keypad portion, a lighting-ON signal is outputted to a lighting device ON/OFF circuit portion from a controlling portion, to cause the lighting device</p>

(backlight) to light, where if not in a voice communication mode, a lighting-ON state is maintained, but if in a voice communication mode, a touch sensor is placed into an operating state by a signal from a controlling portion, and a normal detection output is outputted to the controlling portion and, in addition, if a portion of a human body, such as an ear, makes contact with the touch sensor, a lighting-OFF signal is outputted to the lighting device ON/OFF circuit portion from the controlling portion through an ON output from the touch sensor, to cause the power supply of the lighting device (backlight) to go into the OFF state, and the lighting-OFF state is maintained until the touch sensor is no longer contacted.” Fukiharu 598 at ¶ 0009.

[FIG. 2]

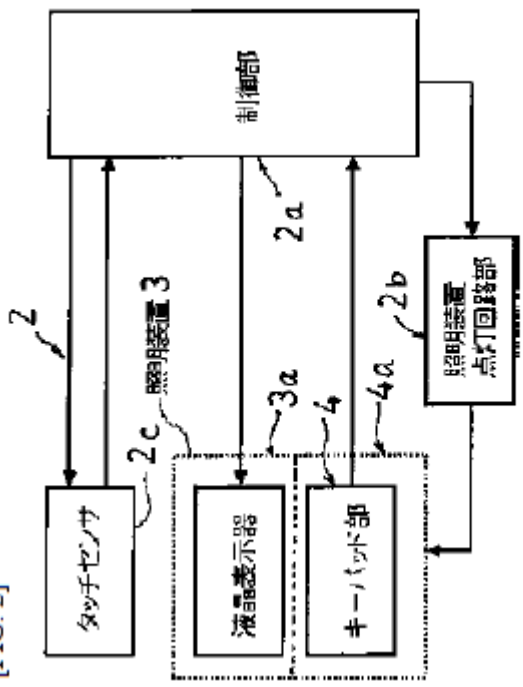

- 2c: Touch Sensor
- 3: Lighting Device
- 3a: Liquid Crystal Display Device
- 4: Keypad Portion
- 2a: Controlling Portion
- 2b: Lighting Device ON/OFF Circuit Portion

Fukiharu 598 at Fig. 2.

“If in the voice communication mode, a touch sensor 2c is placed into an operating state by a signal from the controlling portion 2a, and constantly outputs a detection output to the controlling portion 2a. If the touch sensor 2c contacts a portion of the human body, such as an ear, a lighting-OFF signal is outputted to the lighting device ON/OFF circuit portion 2b from the controlling portion 2a through the ON output of the touch sensor 2c, and the power supplies to both the lighting device (backlight) 3a and the lighting device (backlight) 4a go to the OFF state, and this lighting-OFF state is maintained until the touch sensor 2c goes into a non-contact state. Moreover, when the touch sensor 2c goes from a contact state to a non-contact state, a lighting-ON signal is outputted from the controlling portion 2a to the lighting device ON/OFF circuit portion 2b through the OFF output from the touch sensor 2c, and both the lighting device (backlight) 3a and the lighting device (backlight) 4a go into the ON state, and the lighting-ON state is maintained.” Fukiharu 598 at ¶ 0015.

“A mobile telephone with a lighting device, equipped with a lighting device (backlight) on a liquid crystal display device and/or a keypad portion, comprising: lighting controlling means made from a controlling portion, a lighting device ON/OFF circuit portion, and a touch sensor, wherein: the lighting device (backlight) can be turned ON and OFF by the lighting controlling means.” Fukiharu 598 at Claim 1.

“A mobile telephone with a lighting device as set forth in Claim 1, wherein: a touch sensor that structures the lighting controlling means is activated by the touch sensor contacting a portion of the human body, such as an ear, when listening to the receiver portion.” Fukiharu 598 at Claim 2.

<p>[1f] (c) reduce power to the display if (i) the microprocessor determines that a telephone call is active and (ii) the signal indicates the proximity of the external object; wherein:</p>	<p>Fukiharu 598 discloses the microprocessor adapted to reduce power to the display if (i) the microprocessor determines that a telephone call is active and (ii) the signal indicates the proximity of the external object.</p> <p>For example:</p> <p><i>See</i> discussions of claim elements [1b], [1d], [1e], <i>supra</i>, which are incorporated herein by reference.</p> <p>“Second, a touch sensor that structures the lighting controlling means is activated by the touch sensor contacting a portion of the human body, such as an ear, when listening to the receiver portion. Third, the touch sensor is disposed on the periphery of the receiver of the mobile telephone. Fourth, ON/OFF of the lighting device (backlight) is controlled through a signal that is sent from the controlling portion through a lighting device ON/OFF circuit portion.” Fukiharu 598 at ¶ 0008.</p> <p>“Fifth, a power supply for a mobile telephone is turned ON through pressing of a power supply button of a keypad portion, and, through pressing of a lighting device switch (SW) of a keypad portion, a lighting-ON signal is outputted to a lighting device ON/OFF circuit portion from a controlling portion, to cause the lighting device (backlight) to light, where if not in a voice communication mode, a lighting-ON state is maintained, but if in a voice communication mode, a touch sensor is placed into an operating state by a signal from a controlling portion, and a normal detection output is outputted to the controlling portion and, in addition, if a portion of a human body, such as an ear, makes contact with the touch sensor, a lighting-OFF signal is outputted to the lighting device ON/OFF circuit portion from the controlling portion through an ON output from the touch sensor, to cause the power supply of the lighting device</p>
---	--

(backlight) to go into the OFF state, and the lighting-OFF state is maintained until the touch sensor is no longer contacted.” Fukiharu 598 at ¶ 0009.

“If in the voice communication mode, a touch sensor 2c is placed into an operating state by a signal from the controlling portion 2a, and constantly outputs a detection output to the controlling portion 2a. If the touch sensor 2c contacts a portion of the human body, such as an ear, a lighting-OFF signal is outputted to the lighting device ON/OFF circuit portion 2b from the controlling portion 2a through the ON output of the touch sensor 2c, and the power supplies to both the lighting device (backlight) 3a and the lighting device (backlight) 4a go to the OFF state, and this lighting-OFF state is maintained until the touch sensor 2c goes into a non-contact state. Moreover, when the touch sensor 2c goes from a contact state to a non-contact state, a lighting-ON signal is outputted from the controlling portion 2a to the lighting device ON/OFF circuit portion 2b through the OFF output from the touch sensor 2c, and both the lighting device (backlight) 3a and the lighting device (backlight) 4a go into the ON state, and the lighting-ON state is maintained.” Fukiharu 598 at ¶ 0015.

“Additionally, when the touch sensor 2c is in the noncontact state, if the state changes from the voice communication mode to other than the voice communication mode, the power supply to the touch sensor 2c is cut off, to produce a non-operating state, and the lighting-ON state is maintained.” Fukiharu 598 at ¶ 0016.

“

[FIG. 3]

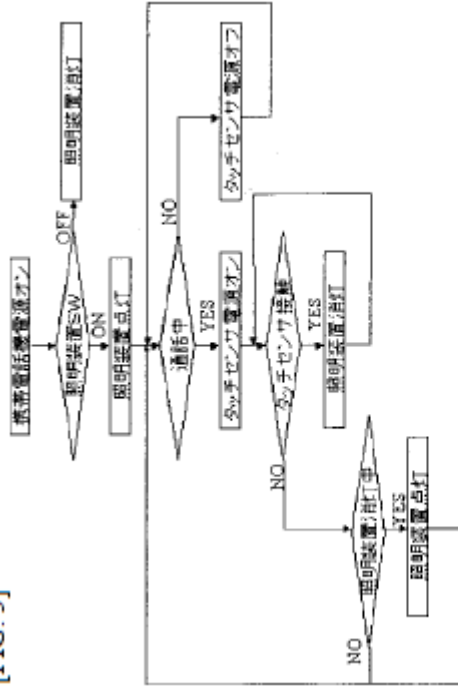

[LOWER LEFT DIAMOND] Lighting device OFF?
 [LOWER LEFT RECTANGLE] Turn lighting device ON.
 [MIDDLE COLUMN, TOP TO BOTTOM]
 Mobile telephone power supply ON
 Lighting device SW?
 Turn lighting device ON.
 Voice communication in process?
 Turn touch sensor power supply ON.
 Touch sensor contacted?
 Turn lighting device OFF.
 [UPPER RIGHT] Turn lighting device OFF.
 [BOTTOM RIGHT] Turn touch sensor power supply OFF. »

Fukiharu 598 at Fig. 3.

“A mobile telephone with a lighting device, equipped with a lighting device (backlight) on a liquid crystal display device and/or a keypad portion, comprising: lighting controlling means made from a controlling portion, a lighting device ON/OFF circuit

portion, and a touch sensor, wherein: the lighting device (backlight) can be turned ON and OFF by the lighting controlling means.” Fukiharu 598 at Claim 1.

“A mobile telephone with a lighting device as set forth in Claim 1, wherein: a touch sensor that structures the lighting controlling means is activated by the touch sensor contacting a portion of the human body, such as an ear, when listening to the receiver portion.” Fukiharu 598 at Claim 2.

“A mobile telephone with a lighting device as set forth in Claim 1, configured so that: ON/OFF of the lighting device (backlight) is controlled through a signal that is sent from the controlling portion through a lighting device ON/OFF circuit portion.” Fukiharu 598 at Claim 4.

“A lighting controlling method for a mobile telephone wherein: the power supply for the mobile telephone is turned ON through pressing of a power supply button of a keypad portion; and through pressing of a lighting device switch (SW) of a keypad portion, a lighting-ON signal is outputted to a lighting device ON/OFF circuit portion from a controlling portion, to cause the lighting device (backlight) to light, where if not in a voice communication mode, a lighting-ON state is maintained, but if in a voice communication mode, a touch sensor is placed into an operating state by a signal from a controlling portion, and a normal detection output is outputted to the controlling portion and, in addition, if a portion of a human body, such as an ear, makes contact with the touch sensor, a lighting-OFF signal is outputted to the lighting device ON/OFF circuit portion from the controlling portion through an ON output from the touch sensor, to cause the power supply of the lighting device (backlight) to go into the OFF state, and the lighting-OFF state is maintained until the touch sensor is no longer contacted.” Fukiharu 598 at Claim 5.

<p>[1g] the telephone call is a wireless telephone call;</p>	<p>Fukiharu 598 discloses the telephone call as a wireless telephone call.</p> <p>For example:</p> <p><i>See</i> discussion of claim elements 1 [a] and 1 [d], <i>supra</i>, which is incorporated herein by reference.</p> <p>“The present invention relates to a lighting device controlling method for a mobile telephone that is light weight and has good portability, and that achieves a reduction in the consumption of electric power through controlling, through a touch sensor that is provided on a receiver portion section, the activation of a lighting device (backlight) for a liquid crystal display device or keypad portion that is equipped in the mobile telephone.” Fukiharu 598 at ¶ 0001.</p> <p>“As mobile telephones of today, there are those that can be used while moving, whether indoors or outdoors, through the use of radio communication as the communicating means.” Fukiharu 598 at ¶ 0002.</p> <p>“Moreover, the electric power consumed by the lighting device (backlight) for lighting the liquid crystal display device or keypad portion, equipped in the conventional mobile telephone, consumes an extremely large amount of electric power compared to the amount of electric power consumed by the circuitry in the various portions for voice communication. In order to take full advantage of the lighting device (backlight) function, the use of a highcapacity battery is required, which, on the other hand, requires an increase in size in the telephone main unit, which causes problems such as reducing portability.” Fukiharu 598 at ¶ 0004.</p>
--	--

“Because of this, even in conventional mobile telephones, there have been a variety of innovations to minimize the need for the lighting device (backlight). For example, while mobile telephones have been developed of a type wherein, for example, when a lighting device (backlight) is lit through, for example, a prescribed sound (audio), or the like, where a timer that is built into the main unit is started when the lighting is turned ON, and the lighting device (backlight) is turned OFF when a time set for the timer has expired, but in controlling the lighting device (backlight) of this mobile telephone, when voice communication is carried out in a location wherein there is a great amount of noise, the lighting device (backlight) that has been turned OFF by the timer will become lit again, and thus there is a problem in that, for example, this cannot conserve electric power effectively.” Fukiharu 598 at ¶0005.

“FIG. 1 is an external view of a mobile telephone with a touch sensor, depicting an embodiment according to the present invention . . .” Fukiharu 598 at ¶0011.

“

[FIG. 1]

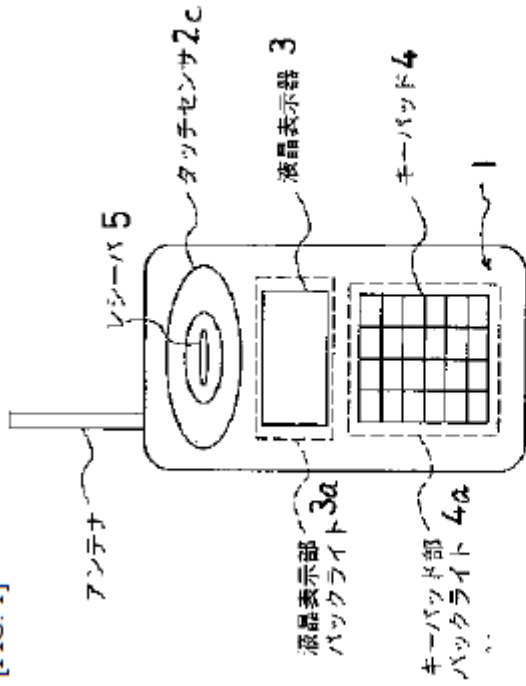

タッチセンサ付き携帯電話機の外観図

[UPPER LEFT] Antenna

5: Receiver

2c: Touch Sensor

3: Liquid Crystal Display Device

4: Keypad

4a: Keypad Portion Backlight

3a: Liquid Crystal Display Portion Backlight

[BOTTOM] Exterior View of Mobile Telephone with Touch Sensor

”

Fukiharu 598 at Fig. 1.

[1h] the microprocessor reduces power to the display while the signal indicates the proximity of the external object only if the microprocessor determines that the wireless telephone call is active; and

Fukiharu 598 discloses that the microprocessor reduces power to the display while the signal indicates the proximity of the external object only if the microprocessor determines that the wireless telephone call is active.

For example:

See discussion of claim element [1f], *supra*, which is incorporated herein by reference.

“Fifth, a power supply for a mobile telephone is turned ON through pressing of a power supply button of a keypad portion, and, through pressing of a lighting device switch (SW) of a keypad portion, a lighting-ON signal is outputted to a lighting device ON/OFF circuit portion from a controlling portion, to cause the lighting device (backlight) to light, where if not in a voice communication mode, a lighting-ON state is maintained, but if in a voice communication mode, a touch sensor is placed into an operating state by a signal from a controlling portion, and a normal detection output is outputted to the controlling portion and, in addition, if a portion of a human body, such as an ear, makes contact with the touch sensor, a lighting-OFF signal is outputted to the lighting device ON/OFF circuit portion from the controlling portion through an ON output from the touch sensor, to cause the power supply of the lighting device (backlight) to go into the OFF state, and the lighting-OFF state is maintained until the touch sensor is no longer contacted.” Fukiharu 598 at ¶ 0009.

“If in the voice communication mode, a touch sensor 2c is placed into an operating state by a signal from the controlling portion 2a, and constantly outputs a detection output to the controlling portion 2a. If the touch sensor 2c contacts a portion of the human body, such as an ear, a lighting-OFF signal is outputted to the lighting device ON/OFF circuit portion 2b from the controlling portion 2a through the ON output of the touch sensor 2c, and the power supplies to both the lighting device (backlight) 3a and the lighting device (backlight) 4a go to the OFF state, and this lighting-OFF state is maintained until the touch sensor 2c goes into a non-contact state. Moreover, when the touch sensor 2c goes from a contact state to a non-contact state, a lighting-ON signal is outputted from the controlling portion 2a to the lighting device ON/OFF circuit portion 2b through the OFF output from the touch sensor 2c, and both the lighting

device (backlight) 3a and the lighting device (backlight) 4a go into the ON state, and the lighting-ON state is maintained.” Fukiharu 598 at ¶ 0015.

“Additionally, when the touch sensor 2c is in the noncontact state, if the state changes from the voice communication mode to other than the voice communication mode, the power supply to the touch sensor 2c is cut off, to produce a non-operating state, and the lighting-ON state is maintained.” Fukiharu 598 at ¶ 0016.

“

[FIG. 3]

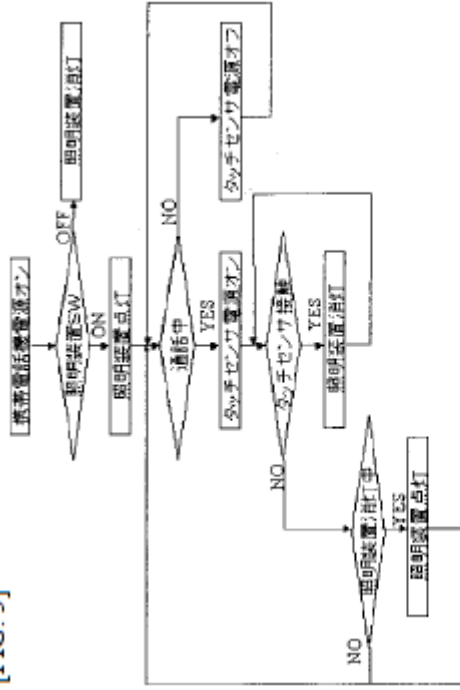

[LOWER LEFT DIAMOND] Lighting device OFF?
 [LOWER LEFT RECTANGLE] Turn lighting device ON.
 [MIDDLE COLUMN, TOP TO BOTTOM]
 Mobile telephone power supply ON
 Lighting device SW?
 Turn lighting device ON.
 Voice communication in process?
 Turn touch sensor power supply ON.
 Touch sensor contacted?
 Turn lighting device OFF.
 [UPPER RIGHT] Turn lighting device OFF.
 [BOTTOM RIGHT] Turn touch sensor power supply OFF. »

Fukiharu 598 at Fig. 3.

“A lighting controlling method for a mobile telephone wherein: the power supply for the mobile telephone is turned ON through pressing of a power supply button of a keypad portion; and through pressing of a lighting device switch (SW) of a keypad portion, a lighting-ON signal is outputted to a lighting device ON/OFF circuit portion

<p>[1i] the proximity sensor begins detecting whether an external object is proximate substantially concurrently with the mobile station initiating an outgoing wireless telephone call or receiving an incoming wireless telephone call.</p>	<p>from a controlling portion, to cause the lighting device (backlight) to light, where if not in a voice communication mode, a lighting-ON state is maintained, but if in a voice communication mode, a touch sensor is placed into an operating state by a signal from a controlling portion, and a normal detection output is outputted to the controlling portion and, in addition, if a portion of a human body, such as an ear, makes contact with the touch sensor, a lighting-OFF signal is outputted to the lighting device ON/OFF circuit portion from the controlling portion through an ON output from the touch sensor, to cause the power supply of the lighting device (backlight) to go into the OFF state, and the lighting-OFF state is maintained until the touch sensor is no longer contacted.” Fukiharu 598 at Claim 5.</p>
<p>[1i] the proximity sensor begins detecting whether an external object is proximate substantially concurrently with the mobile station initiating an outgoing wireless telephone call or receiving an incoming wireless telephone call.</p>	<p>Fukiharu 598 discloses that the proximity sensor begins detecting whether an external object is proximate substantially concurrently with the mobile station initiating an outgoing wireless telephone call or receiving an incoming wireless telephone call.</p> <p>For example:</p> <p><i>See</i> discussion of claim element [1f], <i>supra</i>, which is incorporated herein by reference.</p> <p>“If in the voice communication mode, a touch sensor 2c is placed into an operating state by a signal from the controlling portion 2a, and constantly outputs a detection output to the controlling portion 2a.” Fukiharu 598 at ¶ 0015.</p> <p>“</p>

[FIG. 3]

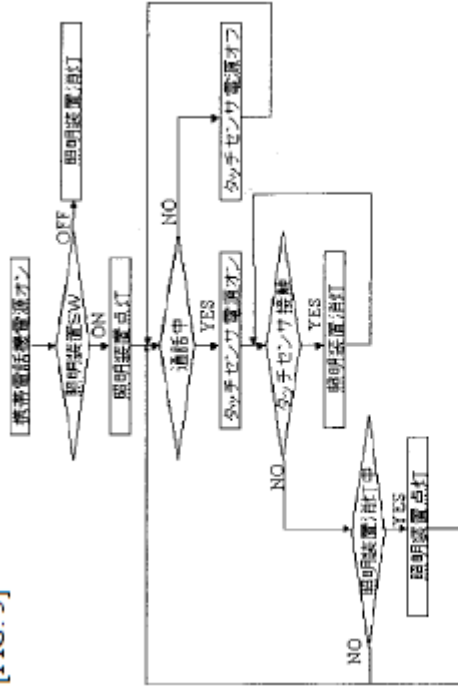

[LOWER LEFT DIAMOND] Lighting device OFF?

[LOWER LEFT RECTANGLE] Turn lighting device ON.

[MIDDLE COLUMN, TOP TO BOTTOM]

Mobile telephone power supply ON

Lighting device SW?

Turn lighting device ON.

Voice communication in process?

Turn touch sensor power supply ON.

Touch sensor contacted?

Turn lighting device OFF.

[UPPER RIGHT] Turn lighting device OFF.

[BOTTOM RIGHT] Turn touch sensor power supply OFF. »

Fukiharu 598 at Fig. 3.

To the extent Fukiharu 598 is deemed to not expressly disclose “the proximity sensor begins detecting whether an external object is proximate substantially concurrently with the mobile station initiating an outgoing wireless telephone call or receiving an incoming wireless telephone call,” Fukiharu 598 inherently discloses this limitation. In

Fukiharu 598, “[j]f in the voice communication mode, a touch sensor 2c is placed into an operating state by a signal from the controlling portion 2a, and constantly outputs a detection output to the controlling portion 2a.” ¶ 0015. A person of ordinary skill in the art at the time of the alleged invention would understand that this occurs “substantially concurrently with the mobile station initiating an outgoing wireless telephone call or receiving an incoming wireless telephone call.” A person of ordinary skill in the art at the time of the alleged invention would understand that “initiating an outgoing wireless telephone call or receiving an incoming wireless telephone call” places a mobile telephone in voice communication mode, and Fukiharu 598 does not suggest any delay from entering voice communication mode to placing touch sensor 2c “into an operating state” in which it “constantly outputs a detection output.” Thus, a person of ordinary skill in the art at the time of the alleged invention would understand Fukiharu 598 to inherently disclose that “the proximity sensor begins detecting whether an external object is proximate substantially concurrently with the mobile station initiating an outgoing wireless telephone call or receiving an incoming wireless telephone call.”

To the extent Fukiharu 598 is deemed to not expressly or inherently disclose “the proximity sensor begins detecting whether an external object is proximate substantially concurrently with the mobile station initiating an outgoing wireless telephone call or receiving an incoming wireless telephone call,” Fukiharu 598 renders it obvious to one of skill in the art to have “the proximity sensor begin[] detecting whether an external object is proximate substantially concurrently with the mobile station initiating an outgoing wireless telephone call or receiving an incoming wireless telephone call.” A person of ordinary skill in the art at the time of the alleged invention would understand that “initiating an outgoing wireless telephone call or receiving an incoming wireless telephone call” places a mobile telephone in voice communication mode, and Fukiharu 598 does not suggest any delay from entering voice communication mode to placing touch sensor 2c “into an operating state” in which it “constantly outputs a detection output.” Thus, it would be obvious to a person of ordinary skill in the art at the time of the alleged invention to have “the proximity sensor begin[] detecting whether an

	external object is proximate substantially concurrently with the mobile station initiating an outgoing wireless telephone call or receiving an incoming wireless telephone call.”
[Claim 2] The mobile station of claim 1, wherein the microprocessor reduces power to the display only if (i) the microprocessor determines that a telephone call is active and (ii) the signal indicates the proximity of the external object.	<p>Fukiharu 598 discloses the microprocessor reducing power to the display only if (i) the microprocessor determines that a telephone call is active and (ii) the signal indicates the proximity of the external object.</p> <p>For example:</p> <p><i>See</i> discussion of claim element [1h], <i>supra</i>, which is incorporated herein by reference.</p>
[Claim 4] The mobile station as recited in claim 1, wherein the microprocessor reduces power to the display by turning off the display.	<p>Fukiharu 598 discloses the microprocessor reducing power to the display by turning off the display.</p> <p>For example:</p> <p>“If the touch sensor 2c contacts a portion of the human body, such as an ear, a lighting-OFF signal is outputted to the lighting device ON/OFF circuit portion 2b from the controlling portion 2a through the ON output of the touch sensor 2c, and the power supplies to both the lighting device (backlight) 3a and the lighting device (backlight) 4a go to the OFF state, and this lighting-OFF state is maintained until the touch sensor 2c goes into a non-contact state.” Fukiharu 598 at ¶ 0015.</p> <p>“</p>

[FIG. 3]

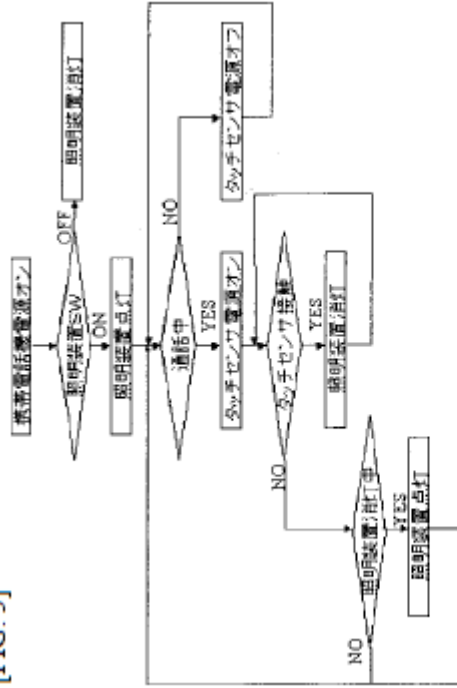

[LOWER LEFT DIAMOND] Lighting device OFF?
[LOWER LEFT RECTANGLE] Turn lighting device ON.
[MIDDLE COLUMN, TOP TO BOTTOM]
Mobile telephone power supply ON
Lighting device SW?
Touch sensor power supply ON.
Voice communication in process?
Turn touch sensor power supply ON.
Touch sensor contacted?
Turn lighting device OFF.
[UPPER RIGHT] Turn lighting device OFF.
[BOTTOM RIGHT] Turn touch sensor power supply OFF. »

Fukiharu 598 at Fig. 3.

[Claim 5] The mobile station as recited in claim 1, wherein the proximity sensor is a mechanical proximity sensor, an optical sensor, or a range-detecting sensor.

Fukiharu 598 discloses that the proximity sensor is a mechanical proximity sensor, an optical sensor, or a range-detecting sensor.

For example:

“FIG. 1 is an external view of a mobile telephone with a touch sensor, depicting an embodiment according to the present invention Fukiharu 598 at ¶ 0011.

[FIG. 1]

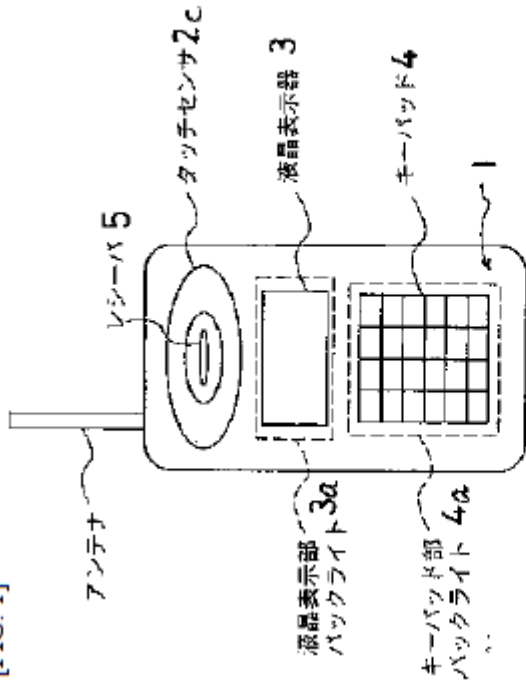

タッチセンサ付き携帯電話機の外観図

[UPPER LEFT] Antenna

5: Receiver

2c: Touch Sensor

3: Liquid Crystal Display Device

4: Keypad

4a: Keypad Portion Backlight

3a: Liquid Crystal Display Portion Backlight

[BOTTOM] Exterior View of Mobile Telephone with Touch Sensor

”

Fukiharu 598 at Fig. 1.

“If the touch sensor 2c contacts a portion of the human body, such as an ear, a lighting-OFF signal is outputted to the lighting device ON/OFF circuit portion 2b from the controlling portion 2a through the ON output of the touch sensor 2c, and the

power supplies to both the lighting device (backlight) 3a and the lighting device (backlight) 4a go to the OFF state, and this lighting-OFF state is maintained until the touch sensor 2c goes into a non-contact state. Moreover, when the touch sensor 2c goes from a contact state to a non-contact state, a lighting-ON signal is outputted from the controlling portion 2a to the lighting device ON/OFF circuit portion 2b through the OFF output from the touch sensor 2c, and both the lighting device (backlight) 3a and the lighting device (backlight) 4a go into the ON state, and the lighting-ON state is maintained.” Fukiharu 598 at ¶ 0015.

To the extent Fukiharu 598 is deemed to not expressly disclose “the proximity sensor is a mechanical proximity sensor, an optical sensor, or a range-detecting sensor,” Fukiharu 598 inherently discloses this limitation. In Fukiharu 598, touch sensor 2c is able to detect contact with a portion of the human body, such as an ear. A person of ordinary skill in the art at the time of the alleged invention would understand that detecting this contact is accomplished by mechanical proximity sensor. Thus, a person of ordinary skill in the art at the time of the alleged invention would understand Fukiharu 598 to inherently disclose “the proximity sensor is a mechanical proximity sensor, an optical sensor, or a range-detecting sensor.”

To the extent Fukiharu 598 is deemed to not expressly or inherently disclose “the proximity sensor is a mechanical proximity sensor, an optical sensor, or a range-detecting sensor,” Fukiharu 598 renders it obvious to one of ordinary skill in the art at the time of the alleged invention to use a mechanical proximity sensor. A person of ordinary skill in the art at the time of the alleged invention would be aware of “conventional mechanical proximity (load) sensors,” which the ’889 Patent identifies as known prior art. *See* ’889 Patent at 3:15-20. A person of ordinary skill in the art at the time of the alleged invention would understand that a mechanical proximity sensor could be used to detect contact with a portion of the human body, such as an ear. Using a mechanical proximity sensor would constitute, at least, combining prior art elements according to known methods to yield predictable results, a simple substitution of one known element for another to obtain predictable results, the use of a known

	<p>technique to improve similar devices in the same way, the application of a known technique to a known device ready for improvement to yield a predictable result, and obvious to try.</p>
<p>[Claim 6] The mobile station as recited in claim 1, wherein the proximity sensor is located proximate to the display.</p>	<p>Fukiharu 598 discloses that the proximity sensor is located proximate to the display.</p> <p>For example:</p> <p>“The object of the present invention is to provide a mobile telephone with a lighting device, and a method for controlling said lighting device, with improved portability through reducing the weight and volume of the battery, and to enable a thorough increase in talk time and standby time, through controlling, through a touch sensor that is provided on a receiver portion surface of the mobile telephone, operation of a lighting device (backlight) of a liquid crystal display device and/or a key pad portion.” Fukiharu 598 at Abstract.</p> <p>“</p>

[FIG. 1]

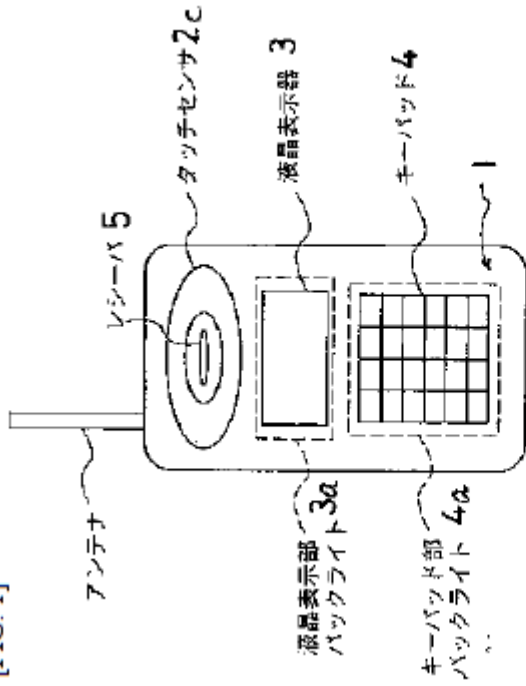

タッチセンサ付き携帯電話機の外観図

[UPPER LEFT] Antenna

5: Receiver

2c: Touch Sensor

3: Liquid Crystal Display Device

4: Keypad

4a: Keypad Portion Backlight

3a: Liquid Crystal Display Portion Backlight

[BOTTOM] Exterior View of Mobile Telephone with Touch Sensor

”

Fukiharu 598 at Fig. 1.

	<p>“A mobile telephone with a lighting device as set forth in Claim 1, wherein: the touch sensor is disposed on the periphery of the receiver of the mobile telephone.” Fukiharu 598 at Claim 3.</p>
<p>[Claim 8 – Preamble] 8. A method of conserving battery power in a mobile station, comprising:</p>	<p>To the extent the preamble is construed as limiting, Fukiharu 598 discloses a method of conserving battery power in a mobile station.</p> <p>For example:</p> <p><i>See</i> discussion of claim elements [1a] and 1[F], <i>supra</i>, which are incorporated herein by reference.</p> <p>“The present invention relates to a lighting device controlling method for a mobile telephone that is light weight and has good portability, and that achieves a reduction in the consumption of electric power through controlling, through a touch sensor that is provided on a receiver portion section, the activation of a lighting device (backlight) for a liquid crystal display device or keypad portion that is equipped in the mobile telephone.” Fukiharu 598 at ¶ 0001.</p> <p>“FIG. 1 is an external view of a mobile telephone with a touch sensor, depicting an embodiment according to the present invention” Fukiharu 598 at ¶ 0011.</p> <p>“</p>

[FIG. 1]

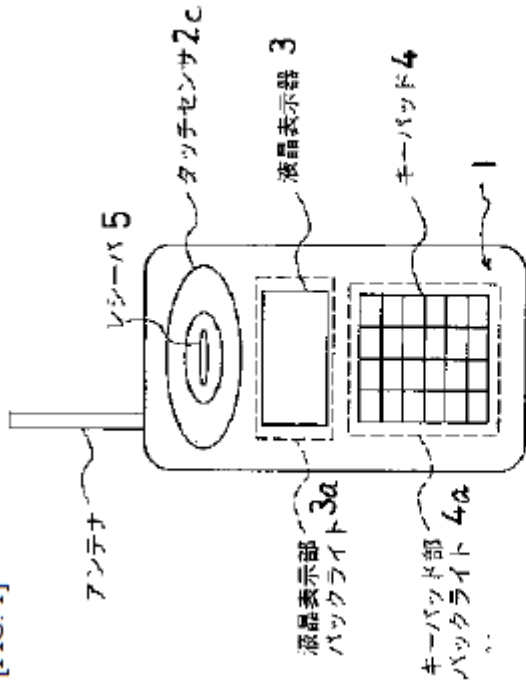

タッチセンサ付き携帯電話機の外観図

[UPPER LEFT] Antenna

5: Receiver

2c: Touch Sensor

3: Liquid Crystal Display Device

4: Keypad

4a: Keypad Portion Backlight

3a: Liquid Crystal Display Portion Backlight

[BOTTOM] Exterior View of Mobile Telephone with Touch Sensor

”

Fukiharu 598 at Fig. 1.

“The present invention, through the use of a structure as described above, enables a reduction in the consumption of battery power, through enabling the lighting devices to be turned OFF when the ear is caused to contact the receiver portion in order to hear the receiver sound during voice communications of a mobile telephone when the

	<p>lighting devices (backlights) for a liquid crystal display device and keypad portion of a mobile telephone are lit, such as that night.” Fukiharu 598 at ¶ 0018.</p> <p>“Moreover, because this can reduce the consumption of electric power of the mobile telephone, this enables an extension in the talk time or the standby time of an individual charging cycle of the battery, and enables a reduction in the volume and weight of the mobile telephone, through achieving miniaturization of the battery.” Fukiharu 598 at ¶ 0019.</p>
<p>[8a] detecting whether an external object is proximate;</p>	<p>Fukiharu 598 discloses detecting whether an external object is proximate.</p> <p>For example:</p> <p><i>See</i> discussion of claim elements [1b] and 1 [e], <i>supra</i>, which are incorporated herein by reference.</p> <p>“If in the voice communication mode, a touch sensor 2c is placed into an operating state by a signal from the controlling portion 2a, and constantly outputs a detection output to the controlling portion 2a. If the touch sensor 2c contacts a portion of the human body, such as an ear, a lighting-OFF signal is outputted to the lighting device ON/OFF circuit portion 2b from the controlling portion 2a through the ON output of the touch sensor 2c, and the power supplies to both the lighting device (backlight) 3a and the lighting device (backlight) 4a go to the OFF state, and this lighting-OFF state is maintained until the touch sensor 2c goes into a non-contact state.” Fukiharu 598 ¶ 0015.</p>

66

[FIG. 3]

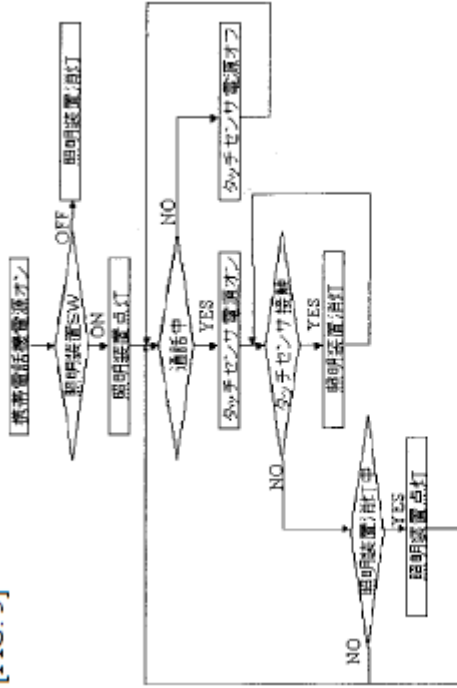

[LOWER LEFT DIAMOND] Lighting device OFF?
 [LOWER LEFT RECTANGLE] Turn lighting device ON.
 [MIDDLE COLUMN, TOP TO BOTTOM]
 Mobile telephone power supply ON
 Lighting device SW?
 Turn lighting device ON.
 Voice communication in process?
 Turn touch sensor power supply ON.
 Touch sensor contacted?
 Turn lighting device OFF.
 [UPPER RIGHT] Turn lighting device OFF.
 [BOTTOM RIGHT] Turn touch sensor power supply OFF. »

Fukiharu 598 at Fig. 3.

[8b] determining whether a telephone call is active; and

Fukiharu 598 discloses determining whether a telephone call is active.

For example:

See discussion of claim element [1d], *supra*, which is incorporated herein by reference.

To the extent Fukiharu 598 is deemed to not expressly disclose this claim limitation, Fukiharu 598 inherently discloses this limitation. *See* discussion of claim element [1d], *supra*, which is incorporated herein by reference.

To the extent Fukiharu 598 is deemed to not expressly or inherently disclose this claim limitation, Fukiharu 598 renders it obvious to one of skill in the art at the time of the alleged invention. *See* discussion of claim element [1d], *supra*, which is incorporated herein by reference.

To the extent Fukiharu 598 is deemed to not expressly or inherently disclose this claim element, it would be obvious to combine the disclosure of Fukiharu 598 with those of Numazawa as described in the Numazawa claim chart, which is incorporated herein in its entirety by reference. *See* discussion of claim element [1d], *supra*, which is incorporated herein by reference.

To the extent Fukiharu 598 is deemed to not expressly or inherently disclose this claim element, it would be obvious to combine the disclosure of Fukiharu 598 with those of Sparre as described in the Sparre claim chart, which is incorporated herein in its entirety by reference. *See* discussion of claim element [1d], *supra*, which is incorporated herein by reference.

To the extent Fukiharu 598 is deemed to not expressly or inherently disclose this claim element, it would be obvious to combine the disclosure of Fukiharu 598 with those of Perez as described in the Perez claim chart, which is incorporated herein in its entirety by reference. *See* discussion of claim element [1d], *supra*, which is incorporated herein by reference.

To the extent Fukiharu 598 is deemed to not expressly or inherently disclose this claim element, it would be obvious to combine the disclosure of Fukiharu 598 with those of

	<p>Mantyarvi as described in the Mantyarvi claim chart, which is incorporated herein in its entirety by reference. <i>See</i> discussion of claim element [1d], <i>supra</i>, which is incorporated herein by reference.</p>
<p>[8c] reducing power consumption of a display of the mobile station if (i) a telephone call is determined to be active and (ii) the proximity of the external object is detected; wherein:</p>	<p>Fukiharu 598 discloses reducing power consumption of a display of the mobile station if (i) a telephone call is determined to be active and (ii) the proximity of the external object is detected.</p> <p>For example:</p> <p><i>See</i> discussion of claim element [1f], <i>supra</i>, which is incorporated herein by reference.</p>
<p>[8d] the telephone call is a wireless telephone call;</p>	<p>Fukiharu 598 discloses that the telephone call is a wireless telephone call.</p> <p>For example:</p> <p><i>See</i> discussion of claim element [1g], <i>supra</i>, which is incorporated herein by reference.</p>
<p>[8e] the power consumption of the display is reduced while the proximity of the external object is detected only if the wireless telephone call is determined to be active; and</p>	<p>Fukiharu 598 discloses that the power consumption of the display is reduced while the proximity of the external object is detected only if the wireless telephone call is determined to be active.</p> <p>For example:</p> <p><i>See</i> discussion of claim element [1h], <i>supra</i>, which is incorporated herein by reference.</p>

<p>[8f] detecting whether an external object is proximate begins substantially concurrently with the mobile station initiating an outgoing wireless telephone call or receiving an incoming wireless telephone call.</p>	<p>Fukiharu 598 discloses that detecting whether an external object is proximate begins substantially concurrently with the mobile station initiating an outgoing wireless telephone call or receiving an incoming wireless telephone call.</p> <p>For example:</p> <p><i>See</i> discussion of claim element [1i], <i>supra</i>, which is incorporated herein by reference.</p> <p>To the extent Fukiharu 598 is deemed to not expressly disclose this claim limitation, Fukiharu 598 inherently discloses this limitation. <i>See</i> discussion of claim element [1i], <i>supra</i>, which is incorporated herein by reference.</p> <p>To the extent Fukiharu 598 is deemed to not expressly or inherently disclose this claim limitation, Fukiharu 598 renders it obvious to one of skill in the art at the time of the alleged invention. <i>See</i> discussion of claim element [1i], <i>supra</i>, which is incorporated herein by reference.</p>
<p>[Claim 12] The method as recited in claim 8, wherein the detecting of the proximity of the external object is performed by a mechanical proximity sensor, an optical sensor, or a range-detecting sensor.</p>	<p>Fukiharu 598 discloses that the detecting of the proximity of the external object is performed by a mechanical proximity sensor, an optical sensor, or a range-detecting sensor.</p> <p>For example:</p> <p><i>See</i> discussion of Claim 5, <i>supra</i>, which is incorporated herein by reference.</p> <p>To the extent Fukiharu 598 is deemed to not expressly disclose this claim limitation, Fukiharu 598 inherently discloses this limitation. <i>See</i> discussion of claim 5, <i>supra</i>, which is incorporated herein by reference.</p>

	<p>To the extent Fukiharu 598 is deemed to not expressly or inherently disclose this claim limitation, Fukiharu 598 renders it obvious to one of skill in the art at the time of the alleged invention. <i>See</i> discussion of claim 5, <i>supra</i>, which is incorporated herein by reference.</p>
--	--

Exhibit A2

**Exhibit #A2-Numazawa
to Defendants' Preliminary Invalidity Contentions**

**Invalidity Chart for U.S. Patent No. 7,319,889
Japanese Unexamined Patent Application Publication No. H11-220432 (“Numazawa”)**

Japanese Unexamined Patent Application Publication No. H11-220432 to Numazawa (“Numazawa”) was published on August 10, 1999. Numazawa is prior art to the ’889 Patent under at least pre-AIA §§ 102(a), 102(b), and 102(c). Numazawa anticipates or renders obvious, alone or in combination with other prior art references, each of the Asserted Claims of the ’889 Patent as described in the chart below and in the main invalidity contentions document to which this chart is annexed.

It would have been obvious under 35 U.S.C. § 103 to a person having ordinary skill in the art at the time of the alleged invention to combine the teachings of Numazawa with the following references:

1. Japanese Unexamined Patent Application Publication No. 2000-106598 to Fukiharu (“Fukiharu 598”). Fukiharu 598 qualifies as prior art under at least pre-AIA §§ 102(a), 102(b), and 102(c). Fukiharu 598 was published on April 11, 2000.
2. U.S. Patent No. 5,586,182 to Miyashita (“Miyashita”). Miyashita qualifies as prior art under at least pre-AIA 35 U.S.C. § 102(c). Miyashita was filed on May 1, 1995 and issued on December 17, 1996.
3. U.S. Patent No. 5,010,566 to Seo (“Seo”). Seo qualifies as prior art under at least pre-AIA 35 U.S.C. §§ 102(a), 102(b), and 102(c). Seo was filed on September 7, 1989 and issued on April 23, 1991.
4. US. Patent Application Publication No. 2004/0225904 A1 to Perez et al. (“Perez”). Perez qualifies as prior art under at least pre-AIA § 102(e). Perez was filed on May 6, 2003 and published on November 11, 2004.

<u>Asserted Claims</u>	<u>Corresponding Disclosure in the Prior Art Reference(s)</u>
[Claim 1 – Preamble] 1. A mobile station, comprising:	<p>Numazawa discloses a mobile station.</p> <p>For example:</p> <p>“Reduced Power Consumption Controlling Method in Wireless Terminal.” Numazawa at Title of the Invention.</p>

“FIG. 1 depicts the structure of a wireless terminal in one embodiment according to the present invention, wherein: 1 is a wireless terminal . . .” Numazawa at ¶ 0016.

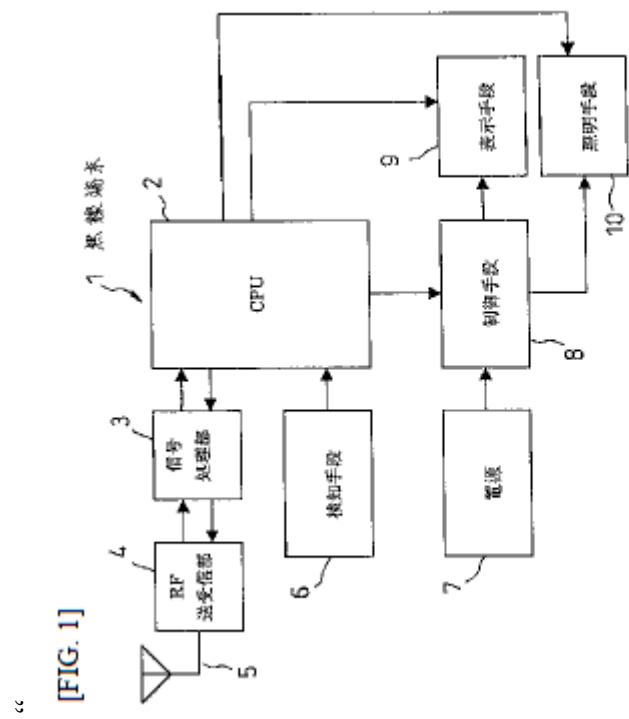

- 4: RF Transceiving Portion
- 3: Signal Processing Portion
- 1: Wireless Terminal
- 6: Detecting Means
- 7: Power Supply
- 8: Controlling Means
- 9: Displaying Means
- 10: Lighting Means

Numazawa at Fig. 1.

“A reduced power consumption controlling method in a wireless terminal, wherein: upon the start of a call, if a function that is unnecessary to the user of the terminal is operating, the operation of the unnecessary function is stopped; and upon termination

<p>[1a] a display;</p>	<p>of the call, the operation of the function that has been stopped is restarted.” Numazawa at Claim 1.</p> <p>Numazawa discloses a display.</p> <p>For example:</p> <p>“Upon identification of contact of the ear to the terminal, controlling means 8 are caused to stop the supply of electric power, from a power supply 7, to displaying means 9 for providing information to a user, and lighting means 10, such as a black light. Even during a call, upon identification that there is a non-contact state between the terminal and the ear, or upon identification, through a signal from a signal processing portion 3, that the call has been terminated, the supply of electric power to the displaying means 9 and the lighting means 10 is restarted.” Numazawa at Abstract.</p> <p>“FIG. 1 depicts the structure of a wireless terminal in one embodiment according to the present invention, wherein: 1 is a wireless terminal; . . . 7 is a power supply for supply electric power to displaying means and lighting means; 8 is controlling means for controlling the displaying means and lighting means depending on the evaluation by the CPU 2; 9 is displaying means for displaying text, the state of the terminal, etc.; and 10 is lighting means, such as a backlight, or the like.” Numazawa at ¶ 0016.</p> <p>“</p>
------------------------	---

[FIG. 1]

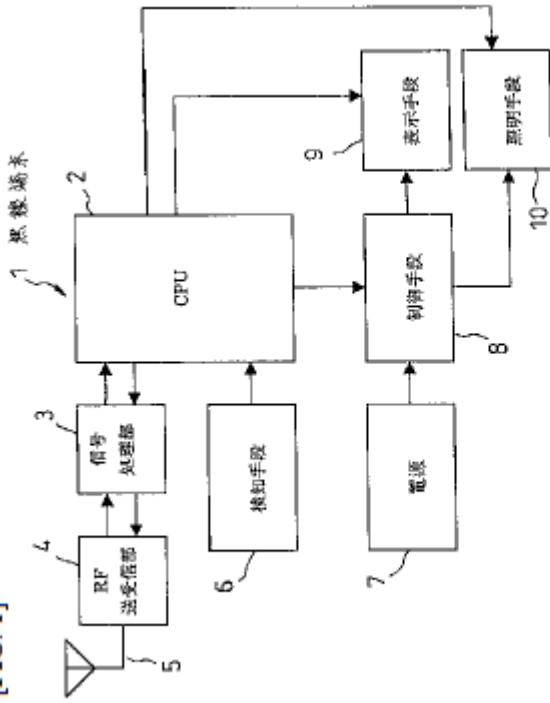

- 4: RF Transceiving Portion
- 3: Signal Processing Portion
- 1: Wireless Terminal
- 6: Detecting Means
- 7: Power Supply
- 8: Controlling Means
- 9: Displaying Means
- 10: Lighting Means

Numazawa at Fig 1.

“A reduced power consumption controlling method in a wireless terminal that has displaying means, wherein: upon the start of a call, if the display on the displaying means becomes unnecessary, the display on the displaying means is stopped, and upon

	<p>termination of the call, the display on the displaying means that has been stopped is restarted.” Numazawa at Claim 2.</p> <p>“A reduced power consumption controlling method as set forth in Claim 2, wherein: if the display on the displaying means is necessary even during a call, the display on the displaying means that had been stopped is restarted.” Numazawa at Claim 3.</p>
<p>[1b] a proximity sensor adapted to generate a signal indicative of proximity of an external object; and</p>	<p>Numazawa discloses a proximity sensor adapted to generate a signal indicative of proximity of an external object.</p> <p>For example:</p> <p>“A CPU 2 identifies start of a call state through a signal from a signal processing portion 3 for controlling communication with a base station, and identifies, through an output signal from detecting means 6, whether or not a user ear is in contact with a terminal. Upon identification of contact of the ear to the terminal, controlling means 8 are caused to stop the supply of electric power, from a power supply 7, to displaying means 9 for providing information to a user, and lighting means 10, such as a black light. Even during a call, upon identification that there is a non-contact state between the terminal and the ear, or upon identification, through a signal from a signal processing portion 3, that the call has been terminated, the supply of electric power to the displaying means 9 and the lighting means 10 is restarted.” Numazawa at Abstract.</p> <p>“In the invention set forth in Claim 6, during a call, whether operation of a function is necessary or not is evaluated through whether or not the receiver is in contact with the ear of the user, and thus there is the effect of being able to start operation of a function immediately when it becomes necessary to start the operation of a function that has</p>

been stopped, when the receiver is removed from the ear of the user, even when in a call state.” Numazawa at ¶ 0014.

“FIG. 1 depicts the structure of a wireless terminal in one embodiment according to the present invention, wherein: 1 is a wireless terminal; 2 is a CPU for evaluating whether or not the wireless terminal is in a call state, whether or not the user has the receiver against his/her ear, etc., and for controlling switching means for starting and stopping the supply of power to the functional block; . . . 6 is detecting means for detecting whether or not the user of the terminal has contacted his/her ear to the terminal; . . .” Numazawa at ¶ 0016.

“When the CPU 2 identifies, through an input signal from the signal processing portion 3, that the call mode has been started, it evaluates, through an input signal from the detecting means 6, whether or not the user has brought the terminal into contact with his or her ear.” Numazawa at ¶ 0017.

“Note that even when, in the CPU 2, the call state has been identified, upon detection, by the detecting means 6, that the user of the terminal has removed the terminal from the ear, the CPU 2 outputs, to the controlling means 8, a signal to start the supply of power from the power supply 7, to thereby start operation of the displaying means 9 and the lighting means 10.” Numazawa at ¶ 0018.

“In Step S3, the output signal from the detecting means 6 is monitored in order to detect whether the user of the wireless terminal has brought the terminal to the ear in the attitude of a call. In this case, when it has been identified, from the output signal from the detecting means 6, that the terminal is in contact with the ear of the user, processing advances to Step S4. Moreover, if it is identified, from the output signal

from the detecting means 6, that the terminal is not in contact with the ear of the user, Step S3 is repeated.” Numazawa at ¶ 0020.

“Next, referencing FIG. 3, in Step S6 the CPU 2 monitors the output signal from the detecting means 6 in order to detect whether or not a call is in progress and the user has the terminal in the attitude of a call. When, in this case, it is identified, from the output signal from the detecting means 6, that the terminal has been separated from the ear of the user, processing advances to Step S7. If the CPU 2 identifies, from the output signal from the detecting means 6, that the terminal is still in contact with the ear of the user, processing advances to Step S11.” Numazawa at ¶ 0022.

“Following this, in Step S8, the CPU 2 monitors the output signal from the detecting means 6 to detect whether or not the user of the terminal has again gone into the attitude of a call. In this case, when the CPU 2 identifies, from the output signal from the detecting means 6, that the terminal is in contact with the ear of the user, processing advances to Step S9. Moreover, if it is identified, from the output signal from the detecting means 6, that the terminal is not in contact with the ear of the user, processing advances to Step S10.” Numazawa at ¶ 0024.

“

[FIG. 1]

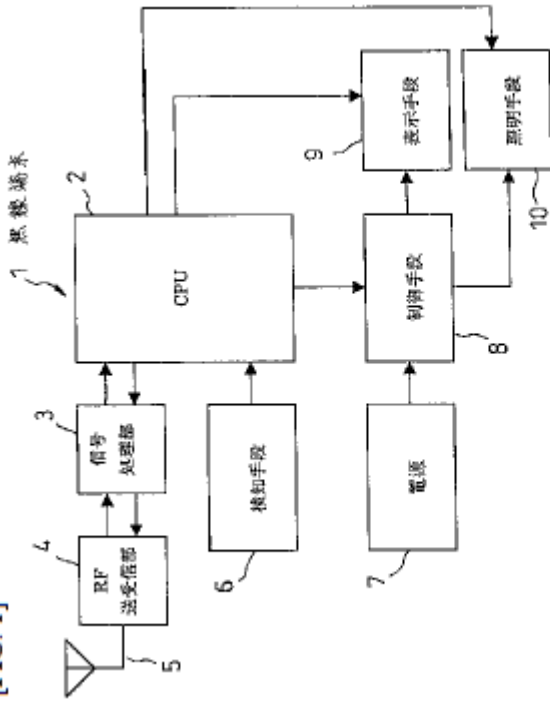

- 4: RF Transceiving Portion
- 3: Signal Processing Portion
- 1: Wireless Terminal
- 6: Detecting Means
- 7: Power Supply
- 8: Controlling Means
- 9: Displaying Means
- 10: Lighting Means

Numazawa at Fig 1.

“

FIG. 2

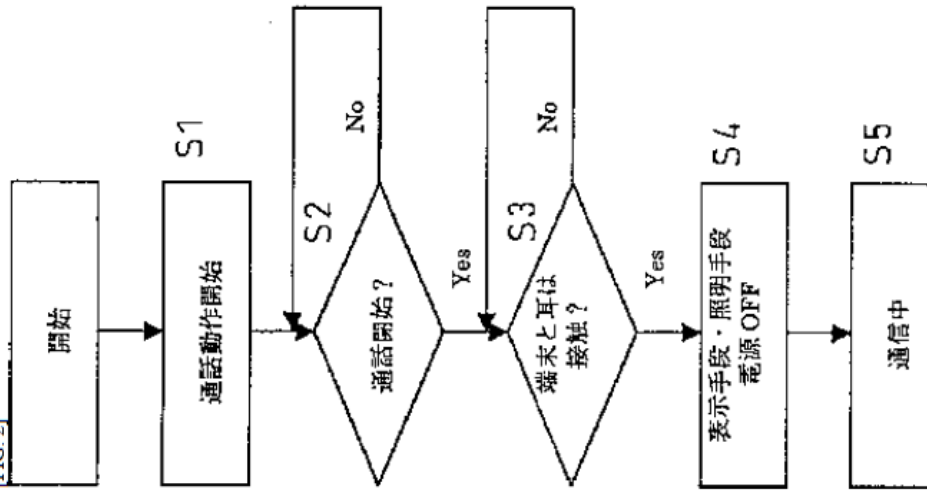

[TOP] Start
S1: Begin Call Operation
S2: Call started?
S3: Terminal and ear in contact?
S4: Turn displaying means/lighting means power supply off.
S5: In Call

Numazawa at Fig 2.

“

[FIG. 3]

S6: Terminal and ear out of contact?
 S7: Turn displaying means/lighting means power supply ON.
 S8: Terminal and ear in contact?
 S9: Turn displaying means/lighting means power supply OFF.
 S10: Call terminated?
 [BOTTOM LEFT] End
 S11: Call terminated?
 S12: Turn displaying means/lighting means power supply ON.

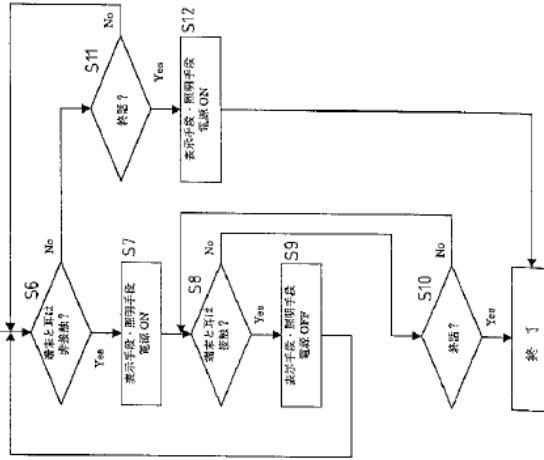

”

Numazawa at Fig 3.

“A reduced power consumption controlling method for a wireless terminal as set forth in any of Claim 1 through 5, wherein: during a call, whether the operation of functions such as displaying means, lighting means, or the like, of a wireless terminal should be stopped or caused to operate is evaluated through detecting contact or non-contact between a receiver and an ear of a user.” Numazawa at Claim 6.

[1c] a microprocessor adapted to:

Numazawa discloses a microprocessor.

For example:

“A CPU 2 identifies start of a call state through a signal from a signal processing portion 3 for controlling communication with a base station, and identifies, through an output signal from detecting means 6, whether or not a user ear is in contact with a terminal.” Numazawa at Abstract.

“FIG. 1 depicts the structure of a wireless terminal in one embodiment according to the present invention, wherein: 1 is a wireless terminal; 2 is a CPU for evaluating whether or not the wireless terminal is in a call state, whether or not the user has the receiver against his/her ear, etc., and for controlling switching means for starting and stopping the supply of power to the functional block” Numazawa at ¶ 0016.

“A summary of the operation of the wireless terminal 1 that uses the method for controlling electric power consumption according to the present invention will be explained next. When the CPU 2 identifies, through an input signal from the signal processing portion 3, that the call mode has been started, it evaluates, through an input signal from the detecting means 6, whether or not the user has brought the terminal into contact with his or her ear. Upon determination that the user of the terminal has brought the terminal into contact with the ear, the CPU 2 causes the controlling means 8 to stop the supply of power from the power supply 7, to stop operation of the displaying means 9 and the lighting means 10. Moreover, upon identification that the call has been terminated, through an input signal from the signal processing portion 3, the CPU 2 outputs, to the controlling means 8, a signal that starts the supply of power from the power supply 7, starting operation of the displaying means 9 and the lighting means 10.” Numazawa at ¶ 0017.

“Note that even when, in the CPU 2, the call state has been identified, upon detection, by the detecting means 6, that the user of the terminal has removed the terminal from the ear, the CPU 2 outputs, to the controlling means 8, a signal to start the supply of power from the power supply 7, to thereby start operation of the displaying means 9 and the lighting means 10.” Numazawa at ¶ 0018.

“The method for controlling conservation of electric power will be explained in detail next, referencing the flowcharts of FIG. 2 and FIG. 3. First, in Step S1 of FIG. 2, an operation is started, through either an outgoing call or incoming call operation, to start a call. Next, in Step S2, in order to evaluate whether or not a call has been started, the CPU 2 monitors the output signal from the signal processing portion 3. If here the CPU 2 identifies, from the output signal from the signal processing portion 3, that a call has been a started, processing advances to Step S3. If the CPU 2 identifies, from the output signal from the signal processing portion 3, that no call has been started, Step S2 is repeated.” Numazawa at ¶ 0019.

“

[FIG. 1]

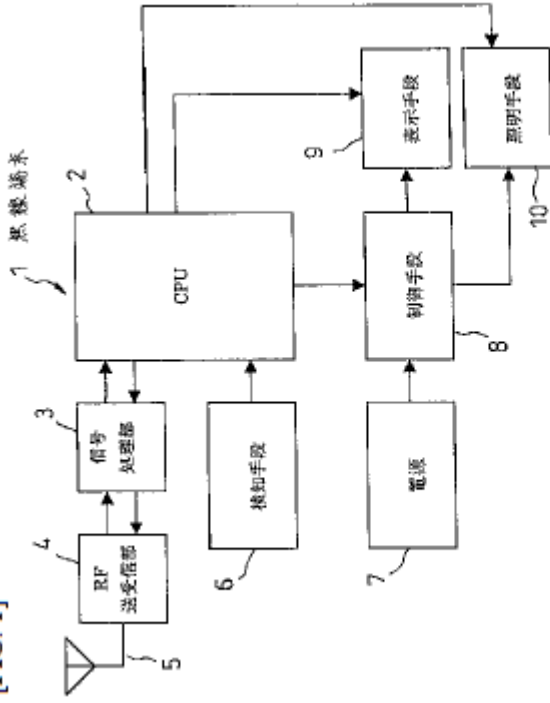

- 4: RF Transceiving Portion
- 3: Signal Processing Portion
- 1: Wireless Terminal
- 6: Detecting Means
- 7: Power Supply
- 8: Controlling Means
- 9: Displaying Means
- 10: Lighting Means

Numazawa at Fig 1.

[1d] (a) determine whether a telephone call is active;

Numazawa discloses the microprocessor adapted to determine whether a telephone call is active.

For example:

“A CPU 2 identifies start of a call state through a signal from a signal processing portion 3 for controlling communication with a base station, and identifies, through an output signal from detecting means 6, whether or not a user ear is in contact with a terminal.” Numazawa at Abstract.

“FIG. 1 depicts the structure of a wireless terminal in one embodiment according to the present invention, wherein: 1 is a wireless terminal; 2 is a CPU for evaluating whether or not the wireless terminal is in a call state, whether or not the user has the receiver against his/her ear, etc., and for controlling switching means for starting and stopping the supply of power to the functional block” Numazawa at ¶ 0016.

“When the CPU 2 identifies, through an input signal from the signal processing portion 3, that the call mode has been started, it evaluates, through an input signal from the detecting means 6, whether or not the user has brought the terminal into contact with his or her ear.” Numazawa at ¶ 0017.

“Note that even when, in the CPU 2, the call state has been identified, upon detection, by the detecting means 6, that the user of the terminal has removed the terminal from the ear, the CPU 2 outputs, to the controlling means 8, a signal to start the supply of power from the power supply 7, to thereby start operation of the displaying means 9 and the lighting means 10.” Numazawa at ¶ 0018.

“Next, in Step S2, in order to evaluate whether or not a call has been started, the CPU 2 monitors the output signal from the signal processing portion 3. If here the CPU 2 identifies, from the output signal from the signal processing portion 3, that a call has been a started, processing advances to Step S3. If the CPU 2 identifies, from the output

signal from the signal processing portion 3, that no call has been started, Step S2 is repeated.” Numazawa at ¶ 0019.

“Following this, in Step S10, the CPU 2 monitors the output signal from the signal processing portion 3 to detect whether or not the wireless terminal has gone into the call terminating state. When, in this case, the CPU 2 identifies, from the output signal from the signal processing portion 3, that the call has been terminated, the displaying means 9 and the lighting means 10 are already operating, so the procedure is terminated, without performing any processing. If it is identified, from the output signal from the signal processing portion 3, that the call has not been terminated, processing returns to Step S8.” Numazawa at ¶ 0026.

“Following this, in Step S11, the CPU 2 monitors the output signal from the signal processing portion 3 to detect whether or not the wireless terminal has gone into the call terminating state. Next, in Step S11, the CPU 2 monitors the output signal from the signal processing portion to detect whether or not the wireless terminal has gone into a call-terminated state. At this time, if the CPU 2 identifies, from the output signal from the signal processing portion 3, that the call has been terminated, processing advances to Step S12. If it is identified, from the output signal from the signal processing portion 3, that the call has not been terminated, processing returns to Step S6.” Numazawa at ¶ 0027.

“

[FIG. 1]

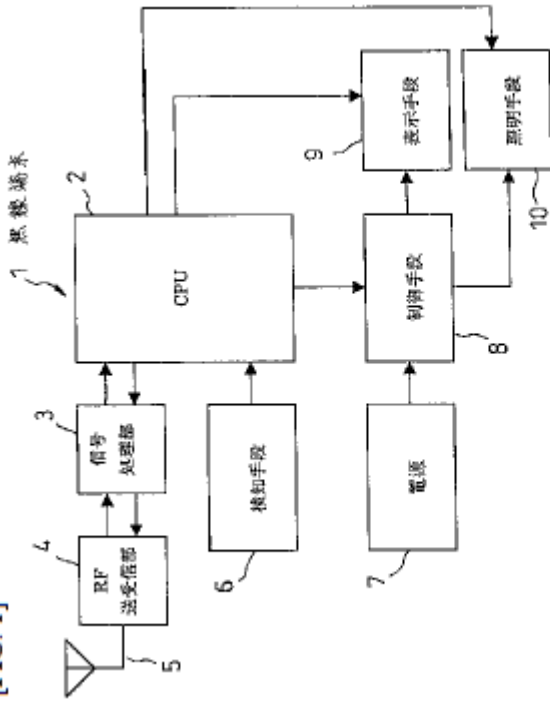

- 4: RF Transceiving Portion
- 3: Signal Processing Portion
- 1: Wireless Terminal
- 6: Detecting Means
- 7: Power Supply
- 8: Controlling Means
- 9: Displaying Means
- 10: Lighting Means

Numazawa at Fig 1.

“

FIG. 2

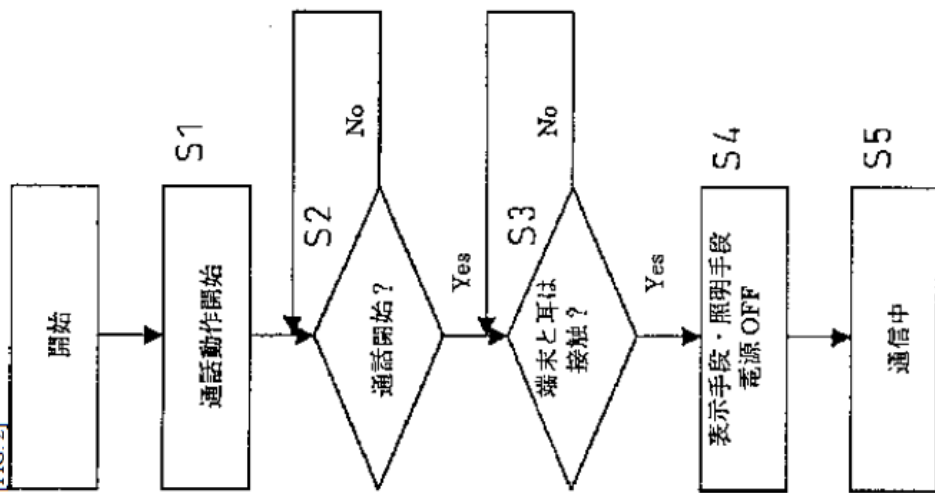

[TOP] Start
S1: Begin Call Operation
S2: Call started?
S3: Terminal and ear in contact?
S4: Turn displaying means/lighting means power supply off.
S5: In Call

Numazawa at Fig 2.

“

[FIG. 3]

S6: Terminal and ear out of contact?
 S7: Turn displaying means/lighting means power supply ON.
 S8: Terminal and ear in contact?
 S9: Turn displaying means/lighting means power supply OFF.
 S10: Call terminated?
 [BOTTOM LEFT] End
 S11: Call terminated?
 S12: Turn displaying means/lighting means power supply ON.

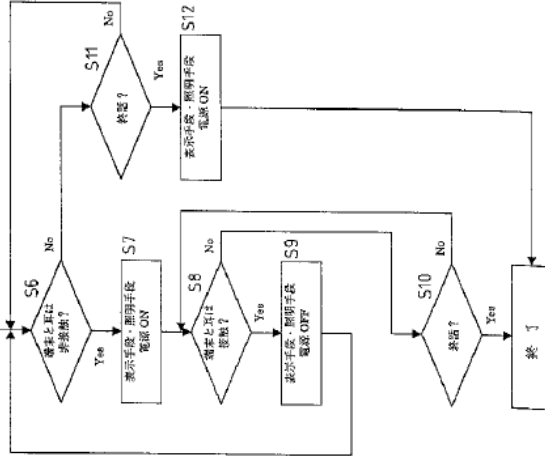

”

Numazawa at Fig 3.

“A reduced power consumption controlling method in a wireless terminal, wherein: upon the start of a call, if a function that is unnecessary to the user of the terminal is operating, the operation of the unnecessary function is stopped; and upon termination of the call, the operation of the function that has been stopped is restarted.”

Numazawa at Claim 1.

“A reduced power consumption controlling method in a wireless terminal that has displaying means, wherein: upon the start of a call, if the display on the displaying means becomes unnecessary, the display on the displaying means is stopped, and upon termination of the call, the display on the displaying means that has been stopped is restarted.” Numazawa at Claim 2.

“A reduced power consumption controlling method as set forth in Claim 2, wherein: if the display on the displaying means is necessary even during a call, the display on the displaying means that had been stopped is restarted.” Numazawa at Claim 3.

“A reduced power consumption controlling method in a wireless terminal that has lighting means, wherein: upon the start of a call, if the illumination of the lighting means becomes unnecessary, the illumination of the lighting means is stopped, and upon termination of the call, the illumination the lighting means that has been stopped is restarted. Numazawa at Claim 4.

“A reduced power consumption controlling method as set forth in Claim 4, wherein: if the illumination of the lighting means is necessary even during a call, the illumination of the lighting means that had been stopped is restarted.” Numazawa at Claim 5.

“A reduced power consumption controlling method for a wireless terminal as set forth in any of Claim 1 through 5, wherein: during a call, whether the operation of functions such as displaying means, lighting means, or the like, of a wireless terminal should be

	<p>stopped or caused to operate is evaluated through detecting contact or non-contact between a receiver and an ear of a user.” Numazawa at Claim 6.</p> <p>To the extent Numazawa is deemed to not expressly disclose the microprocessor adapted to “determine whether a telephone call is active,” Numazawa inherently discloses this limitation. In Numazawa, the CPU 2 identifies the start of a call state through a signal from a signal processing portion 3. A person of skill in the art would understand that identifying the start of a call state necessarily includes determining whether a telephone call is active.</p> <p>To the extent Numazawa is deemed to not expressly or inherently disclose a microprocessor adapted to “determine whether a telephone call is active,” Numazawa renders it obvious to one of skill in the art to use a microprocessor adapted to “determine whether a telephone call is active.” A person of ordinary skill in the art would understand that identifying the start of a call state includes determining whether a telephone call is active. Thus, it would be obvious to a person of skill in the art for signal processing portion 3 to identify this to CPU 2, and the CPU would, therefore, “determine whether a telephone call is active.”</p>
<p>[1e] (b) receive the signal from the proximity sensor; and</p>	<p>Numazawa discloses the microprocessor adapted to receive the signal from the proximity sensor.</p> <p>For example:</p> <p><i>See</i> discussion of claim element [1b], <i>supra</i>, which is incorporated herein by reference.</p> <p>“When the CPU 2 identifies, through an input signal from the signal processing portion 3, that the call mode has been started, it evaluates, through an input signal from the detecting means 6, whether or not the user has brought the terminal into contact with his or her ear.” Numazawa at ¶ 0017.</p>

“In Step S3, the output signal from the detecting means 6 is monitored in order to detect whether the user of the wireless terminal has brought the terminal to the ear in the attitude of a call. In this case, when it has been identified, from the output signal from the detecting means 6, that the terminal is in contact with the ear of the user, processing advances to Step S4. Moreover, if it is identified, from the output signal from the detecting means 6, that the terminal is not in contact with the ear of the user, Step S3 is repeated.” Numazawa at ¶ 0020.

“Next, referencing FIG. 3, in Step S6 the CPU 2 monitors the output signal from the detecting means 6 in order to detect whether or not a call is in progress and the user has the terminal in the attitude of a call. When, in this case, it is identified, from the output signal from the detecting means 6, that the terminal has been separated from the ear of the user, processing advances to Step S7. If the CPU 2 identifies, from the output signal from the detecting means 6, that the terminal is still in contact with the ear of the user, processing advances to Step S11.” Numazawa at ¶ 0022.

“Following this, in Step S8, the CPU 2 monitors the output signal from the detecting means 6 to detect whether or not the user of the terminal has again gone into the attitude of a call. In this case, when the CPU 2 identifies, from the output signal from the detecting means 6, that the terminal is in contact with the ear of the user, processing advances to Step S9. Moreover, if it is identified, from the output signal from the detecting means 6, that the terminal is not in contact with the ear of the user, processing advances to Step S10.” Numazawa at ¶ 0024.

“

[FIG. 1]

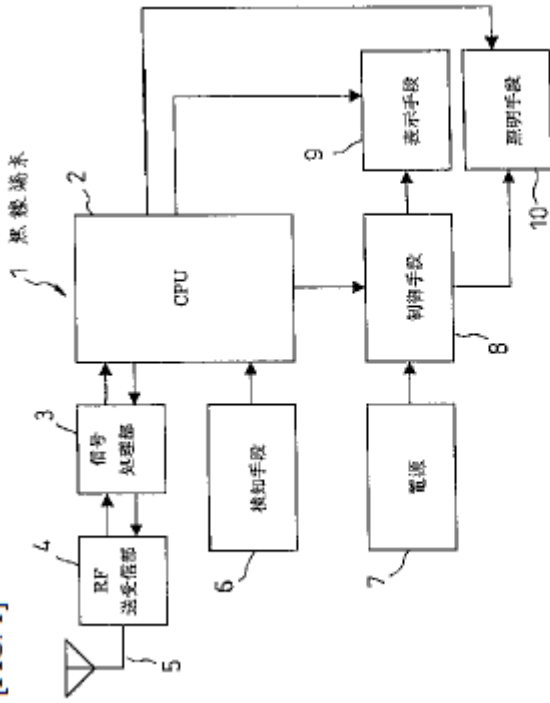

- 4: RF Transceiving Portion
- 3: Signal Processing Portion
- 1: Wireless Terminal
- 6: Detecting Means
- 7: Power Supply
- 8: Controlling Means
- 9: Displaying Means
- 10: Lighting Means

Numazawa at Fig 1.

"

FIG. 2

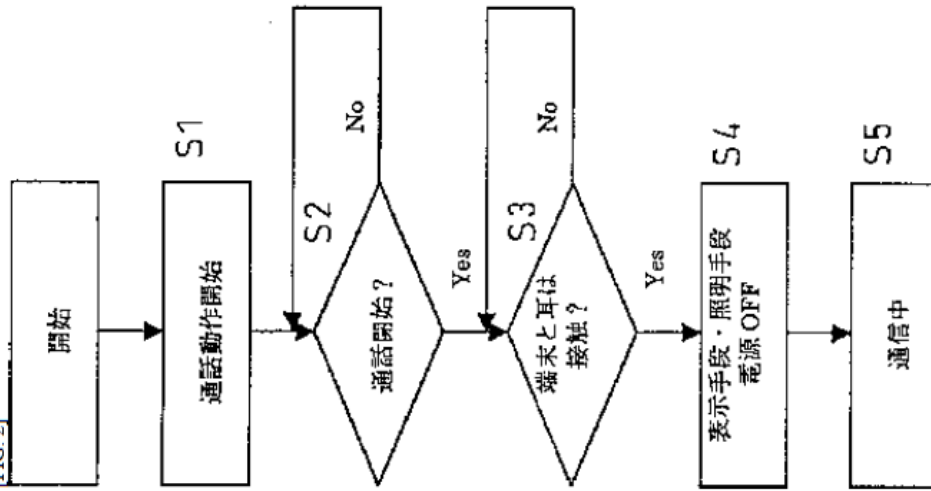

[TOP] Start
S1: Begin Call Operation
S2: Call started?
S3: Terminal and ear in contact?
S4: Turn displaying means/lighting means power supply off.
S5: In Call

»

Numazawa at Fig 2.

“

[FIG. 3]

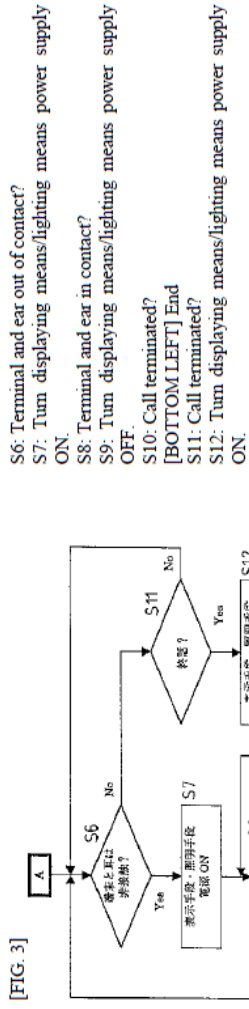

”

Numazawa at Fig 3.

[11] (c) reduce power to the display if (i) the microprocessor determines that a telephone call is active and (ii) the signal indicates the proximity of the external object; wherein:

Numazawa discloses the microprocessor adapted to reduce power to the display if (i) the microprocessor determines that a telephone call is active and (ii) the signal indicates the proximity of the external object.

For example:

See discussions of claim elements [1b], [1d], [1e], *supra*, which are incorporated herein by reference.

“In the invention set forth in Claim 6, during a call, whether operation of a function is necessary or not is evaluated through whether or not the receiver is in contact with the ear of the user, and thus there is the effect of being able to start operation of a function immediately when it becomes necessary to start the operation of a function that has been stopped, when the receiver is removed from the ear of the user, even when in a call state.” Numazawa at ¶ 0014.

“A summary of the operation of the wireless terminal 1 that uses the method for controlling electric power consumption according to the present invention will be explained next. When the CPU 2 identifies, through an input signal from the signal processing portion 3, that the call mode has been started, it evaluates, through an input signal from the detecting means 6, whether or not the user has brought the terminal into contact with his or her ear. Upon determination that the user of the terminal has brought the terminal into contact with the ear, the CPU 2 causes the controlling means 8 to stop the supply of power from the power supply 7, to stop operation of the displaying means 9 and the lighting means 10. Moreover, upon identification that the call has been terminated, through an input signal from the signal processing portion 3, the CPU 2 outputs, to the controlling means 8, a signal that starts the supply of power from the power supply 7, starting operation of the displaying means 9 and the lighting means 10.” Numazawa at ¶ 0017.

“Next, in Step S2, in order to evaluate whether or not a call has been started, the CPU 2 monitors the output signal from the signal processing portion 3. If here the CPU 2 identifies, from the output signal from the signal processing portion 3, that a call has been a started, processing advances to Step S3.” Numazawa at ¶ 0019.

“In Step S3, the output signal from the detecting means 6 is monitored in order to detect whether the user of the wireless terminal has brought the terminal to the ear in the attitude of a call. In this case, when it has been identified, from the output signal from the detecting means 6, that the terminal is in contact with the ear of the user, processing advances to Step S4. Moreover, if it is identified, from the output signal from the detecting means 6, that the terminal is not in contact with the ear of the user, Step S3 is repeated.” Numazawa at ¶ 0020.

“Following this, in Step S4, the CPU 2 outputs, to the controlling means 8, a signal for stopping the displaying means 9 and the lighting means 10. Through this, the controlling means 8 stop the supply of power from the power supply 7 to the displaying means 9 and the lighting means 10, and the displaying means 9 and lighting means 10 stop operating. Thereafter, processing advances to Step S5, and the call is carried out in a state wherein unnecessary power consumption has been reduced.” Numazawa at ¶ 0021.

“Next, referencing FIG. 3, in Step S6 the CPU 2 monitors the output signal from the detecting means 6 in order to detect whether or not a call is in progress and the user has the terminal in the attitude of a call. When, in this case, it is identified, from the output signal from the detecting means 6, that the terminal has been separated from the ear of the user, processing advances to Step S7. If the CPU 2 identifies, from the output signal from the detecting means 6, that the terminal is still in contact with the ear of the user, processing advances to Step S11.” Numazawa at ¶ 0022.

“Next, in Step S7, the CPU 2 outputs, to the controlling means 8, a signal to start operation of the displaying means 9 and the lighting means 10. Through this, the controlling means 8 start the operation of the displaying means 9 and the lighting

means 10 through causing power to be supplied to the displaying means 9 and the lighting means 10 from the power supply 7. Thereafter, processing advances to Step S8.” Numazawa at ¶ 0023.

“Following this, in Step S8, the CPU 2 monitors the output signal from the detecting means 6 to detect whether or not the user of the terminal has again gone into the attitude of a call. In this case, when the CPU 2 identifies, from the output signal from the detecting means 6, that the terminal is in contact with the ear of the user, processing advances to Step S9. Moreover, if it is identified, from the output signal from the detecting means 6, that the terminal is not in contact with the ear of the user, processing advances to Step S10.” Numazawa at ¶ 0024.

“Next, in Step S9, the CPU 2, in order to again stop the displaying means 9 and the lighting means 10, outputs, to the controlling means 8, a signal to stop the displaying means 9 and the lighting means 10. Through this, the controlling means 8 stop the supply of power from the power supply 7 to the displaying means 9 and the lighting means 10, to thereby stop operation of the displaying means 9 and the lighting means 10. Thereafter, processing returns to Step S6.” Numazawa at ¶ 0025.

“Following this, in Step S10, the CPU 2 monitors the output signal from the signal processing portion 3 to detect whether or not the wireless terminal has gone into the call terminating state. When, in this case, the CPU 2 identifies, from the output signal from the signal processing portion 3, that the call has been terminated, the displaying means 9 and the lighting means 10 are already operating, so the procedure is terminated, without performing any processing. If it is identified, from the output signal from the signal processing portion 3, that the call has not been terminated, processing returns to Step S8.” Numazawa at ¶ 0026.

“Following this, in Step S11, the CPU 2 monitors the output signal from the signal processing portion 3 to detect whether or not the wireless terminal has gone into the call terminating state. Next, in Step S11, the CPU 2 monitors the output signal from the signal processing portion to detect whether or not the wireless terminal has gone into a call-terminated state. At this time, if the CPU 2 identifies, from the output signal from the signal processing portion 3, that the call has been terminated, processing advances to Step S12. If it is identified, from the output signal from the signal processing portion 3, that the call has not been terminated, processing returns to Step S6.” Numazawa at ¶ 0027.

“Following this, in Step S12, the CPU 2 outputs a signal to the controlling means 8 to start operation of the displaying means 9 and the lighting means 10, in order to start the operation of the displaying means 9 and the lighting means 10. Through this, the controlling means 8 start the operation of the displaying means 9 and the lighting means 10 through causing power to be supplied to the displaying means 9 and the lighting means 10 from the power supply 7.” Numazawa at ¶ 0028.

“

FIG. 2

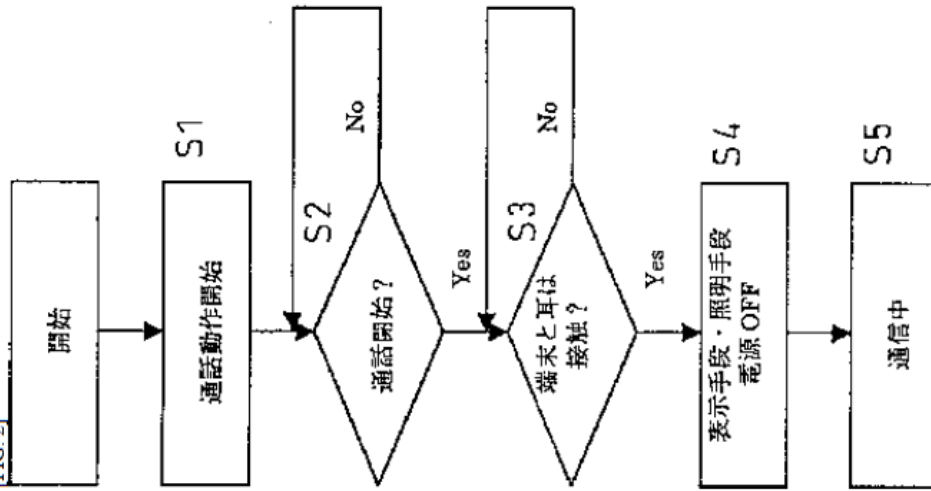

[TOP] Start
S1: Begin Call Operation
S2: Call started?
S3: Terminal and ear in contact?
S4: Turn displaying means/lighting means power supply off.
S5: In Call

»

Numazawa at Fig 2.

“

[FIG. 3]

- S6: Terminal and ear out of contact?
- S7: Turn displaying means/lighting means power supply ON.
- S8: Terminal and ear in contact?
- S9: Turn displaying means/lighting means power supply OFF.
- S10: Call terminated?
- [BOTTOM LEFT] End
- S11: Call terminated?
- S12: Turn displaying means/lighting means power supply ON.

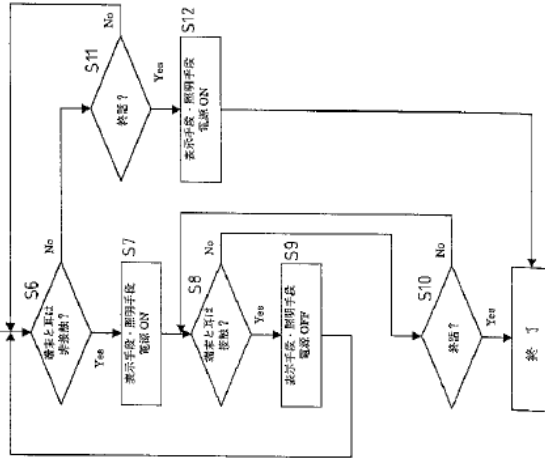

”

Numazawa at Fig 3.

“A reduced power consumption controlling method for a wireless terminal as set forth in any of Claim 1 through 5, wherein: during a call, whether the operation of functions such as displaying means, lighting means, or the like, of a wireless terminal should be stopped or caused to operate is evaluated through detecting contact or non-contact between a receiver and an ear of a user.” Numazawa at Claim 6.

<p>[1g] the telephone call is a wireless telephone call;</p>	<p>Numazawa discloses the telephone call as a wireless telephone call.</p> <p>For example:</p> <p><i>See</i> discussions of claim elements [1a] and [1d], <i>supra</i>, which are incorporated herein by reference.</p> <p>“The present invention relates to a reduced power consumption controlling method in a wireless terminal for reducing power consumption by stopping operation of unnecessary functions during a call.” Numazawa at ¶ 0001.</p> <p>“In the present invention, control is such that, upon determination that the wireless terminal is in a call, operation of functions believe be unnecessary, due to the user of the terminal being in a call, is stopped, and upon termination of the call, operation of the stopped functions is restarted.” Numazawa at ¶ 0005.</p> <p>“FIG. 1 depicts the structure of a wireless terminal in one embodiment according to the present invention, wherein: 1 is a wireless terminal; 2 is a CPU for evaluating whether or not the wireless terminal is in a call state, whether or not the user has the receiver against his/her ear, etc., and for controlling switching means for starting and stopping the supply of power to the functional block; 3 is a signal processing portion for processing signals of a base station; 4 is an RF transceiving portion for sending and receiving radio signals through an antenna wire 5; 6 is detecting means for detecting whether or not the user of the terminal has contacted his/her ear to the terminal; 7 is a power supply for supply electric power to displaying means and lighting means; 8 is controlling means for controlling the displaying means and lighting means depending on the evaluation by the CPU 2; 9 is displaying means for displaying text, the state of</p>
--	---

the terminal, etc.; and 10 is lighting means, such as a backlight, or the like.”
 Numazawa at ¶ 0016.

“

[FIG. 1]

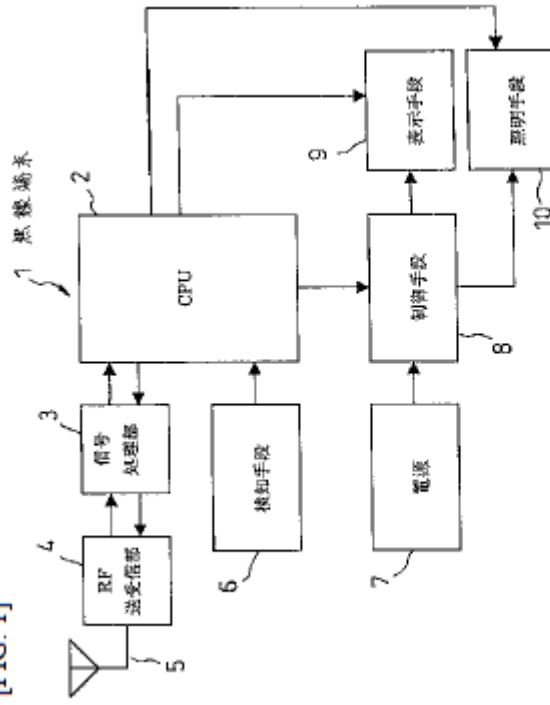

- 4: RF Transceiving Portion
- 3: Signal Processing Portion
- 1: Wireless Terminal
- 6: Detecting Means
- 7: Power Supply
- 8: Controlling Means
- 9: Displaying Means
- 10: Lighting Means

Numazawa at Fig 1.

”

<p>[1h] the microprocessor reduces power to the display while the signal indicates the proximity of the external object only if the microprocessor determines that the wireless telephone call is active; and</p>	<p>Numazawa discloses that the microprocessor reduces power to the display while the signal indicates the proximity of the external object only if the microprocessor determines that the wireless telephone call is active.</p> <p>For example:</p> <p><i>See</i> discussion of claim element [1f], <i>supra</i>, which is incorporated herein by reference.</p> <p>“In the invention set forth in Claim 6, during a call, whether operation of a function is necessary or not is evaluated through whether or not the receiver is in contact with the ear of the user, and thus there is the effect of being able to start operation of a function immediately when it becomes necessary to start the operation of a function that has been stopped, when the receiver is removed from the ear of the user, even when in a call state.” Numazawa at ¶ 0014.</p> <p>“When the CPU 2 identifies, through an input signal from the signal processing portion 3, that the call mode has been started, it evaluates, through an input signal from the detecting means 6, whether or not the user has brought the terminal into contact with his or her ear. Upon determination that the user of the terminal has brought the terminal into contact with the ear, the CPU 2 causes the controlling means 8 to stop the supply of power from the power supply 7, to stop operation of the displaying means 9 and the lighting means 10.” Numazawa at ¶ 0017.</p> <p>“Next, in Step S2, in order to evaluate whether or not a call has been started, the CPU 2 monitors the output signal from the signal processing portion 3. If here the CPU 2</p>
---	--

identifies, from the output signal from the signal processing portion 3, that a call has been a started, processing advances to Step S3.” Numazawa at ¶ 0019.

“In Step S3, the output signal from the detecting means 6 is monitored in order to detect whether the user of the wireless terminal has brought the terminal to the ear in the attitude of a call. In this case, when it has been identified, from the output signal from the detecting means 6, that the terminal is in contact with the ear of the user, processing advances to Step S4. Moreover, if it is identified, from the output signal from the detecting means 6, that the terminal is not in contact with the ear of the user, Step S3 is repeated.” Numazawa at ¶ 0020.

“Following this, in Step S4, the CPU 2 outputs, to the controlling means 8, a signal for stopping the displaying means 9 and the lighting means 10. Through this, the controlling means 8 stop the supply of power from the power supply 7 to the displaying means 9 and the lighting means 10, and the displaying means 9 and lighting means 10 stop operating. Thereafter, processing advances to Step S5, and the call is carried out in a state wherein unnecessary power consumption has been reduced.” Numazawa at ¶ 0021.

“

FIG. 2

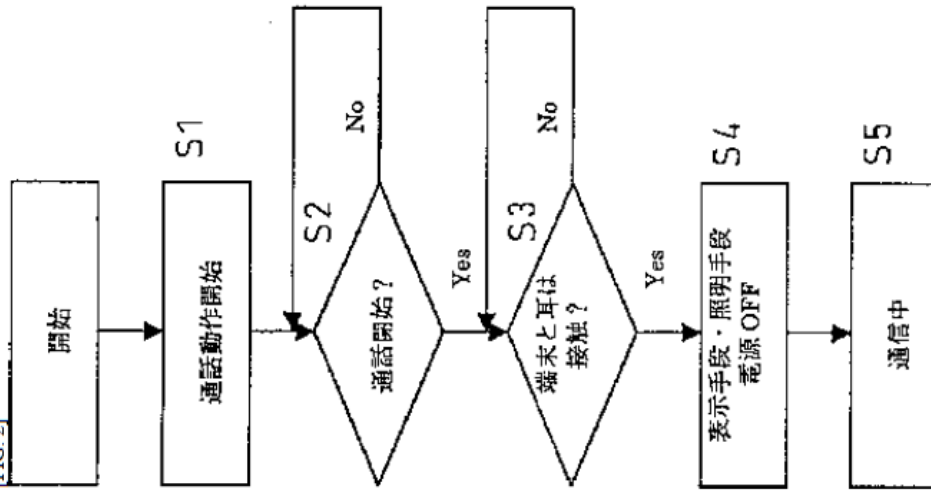

[TOP] Start
S1: Begin Call Operation
S2: Call started?
S3: Terminal and ear in contact?
S4: Turn displaying means/lighting means power supply off.
S5: In Call

»

	<p>Numazawa at Fig 2.</p> <p>“A reduced power consumption controlling method for a wireless terminal as set forth in any of Claim 1 through 5, wherein: during a call, whether the operation of functions such as displaying means, lighting means, or the like, of a wireless terminal should be stopped or caused to operate is evaluated through detecting contact or non-contact between a receiver and an ear of a user.” Numazawa at Claim 6.</p>
<p>[11] the proximity sensor begins detecting whether an external object is proximate substantially concurrently with the mobile station initiating an outgoing wireless telephone call or receiving an incoming wireless telephone call.</p>	<p>Numazawa discloses that the proximity sensor begins to detect whether an external object is proximate substantially concurrently with the mobile station initiating an outgoing wireless telephone call or receiving an incoming wireless telephone call:</p> <p>For example:</p> <p><i>See</i> discussion of claim element [1f], <i>supra</i>, which is incorporated herein by reference.</p> <p>“When the CPU 2 identifies, through an input signal from the signal processing portion 3, that the call mode has been started, it evaluates, through an input signal from the detecting means 6, whether or not the user has brought the terminal into contact with his or her ear.” Numazawa at ¶ 0017.</p> <p>“Next, in Step S2, in order to evaluate whether or not a call has been started, the CPU 2 monitors the output signal from the signal processing portion 3. If here the CPU 2 identifies, from the output signal from the signal processing portion 3, that a call has been a started, processing advances to Step S3.” Numazawa at ¶ 0019.</p>

“In Step S3, the output signal from the detecting means 6 is monitored in order to detect whether the user of the wireless terminal has brought the terminal to the ear in the attitude of a call.” Numazawa at ¶ 0020.

“

FIG. 2

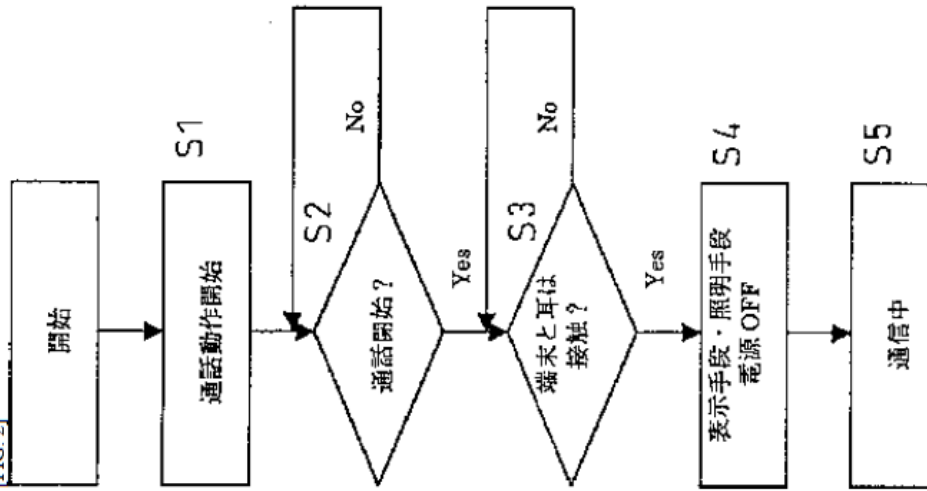

[TOP] Start
S1: Begin Call Operation
S2: Call started?
S3: Terminal and ear in contact?
S4: Turn displaying means/lighting means power supply off.
S5: In Call

»

Numazawa at Fig. 2.

To the extent Numazawa is deemed to not expressly disclose “the proximity sensor begins detecting whether an external object is proximate substantially concurrently with the mobile station initiating an outgoing wireless telephone call or receiving an incoming wireless telephone call,” Numazawa inherently discloses this limitation. In Numazawa, the CPU 2 monitors the output signal from the detecting means 6 only after the CPU 2 identifies that a call has been started. A person of ordinary skill in the art at the time of the alleged invention would understand that “initiating an outgoing wireless telephone call or receiving an incoming wireless telephone call” is necessarily how a call is started. Further, a person of ordinary skill in the art would understand that “the proximity sensor begins detecting whether an external object is proximate substantially concurrently with the mobile station initiating an outgoing wireless telephone call or receiving an incoming wireless telephone call” because Numazawa discloses that this is when the CPU 2 monitors the output signal from the detecting means. Thus, a person of ordinary skill in the art at the time of the alleged invention would understand Numazawa to inherently disclose that “the proximity sensor begins detecting whether an external object is proximate substantially concurrently with the mobile station initiating an outgoing wireless telephone call or receiving an incoming wireless telephone call or receiving an incoming wireless telephone call.”

To the extent Numazawa is deemed to not expressly or inherently disclose “the proximity sensor begins detecting whether an external object is proximate substantially concurrently with the mobile station initiating an outgoing wireless telephone call or receiving an incoming wireless telephone call,” Numazawa renders it obvious to one of skill in the art to have “the proximity sensor begin[] detecting whether an external object is proximate substantially concurrently with the mobile station initiating an outgoing wireless telephone call or receiving an incoming wireless telephone call.” A person of ordinary skill in the art at the time of the alleged invention would understand that “initiating an outgoing wireless telephone call or receiving an incoming wireless telephone call” is necessarily how a call is started. Further, it would be obvious to a

person of ordinary skill in the art at the time of the alleged invention for “the proximity sensor [to] begin[] detecting whether an external object is proximate substantially concurrently with the mobile station initiating an outgoing wireless telephone call or receiving an incoming wireless telephone call” because that is the only time when Numazawa discloses that the CPU 2 monitors the output signal for the detecting means. Because this is the only time that the signal is monitored, it would be obvious to a person of ordinary skill in the art at the time of the alleged invention that the proximity sensor should begin detecting substantially concurrently with the start of this period in order to save additional power.

To the extent Numazawa is deemed to not expressly or inherently disclose “the proximity sensor begins detecting whether an external object is proximate substantially concurrently with the mobile station initiating an outgoing wireless telephone call or receiving an incoming wireless telephone call,” it would be obvious to combine the disclosure of Numazawa with those of Fukiharu 598 as described in the Fukiharu 598 claim chart, which is incorporated herein in its entirety by reference. Numazawa and Fukiharu 598 are both directed to conserving battery power in mobile stations generally and more particularly at conserving battery power in mobile stations by using sensors to detect when the user of the mobile station is in a call and unlikely to be looking at the display (as when, for example, the proximity sensor detects the user’s ear by the mobile station) and to power off the display of mobile stations at such times. Numazawa at ¶ Abstract (“To achieve reduced power consumption through stopping operation of unnecessary functions during use of a wireless terminal. A CPU 2 identifies start of a call state through a signal from a signal processing portion 3 for controlling communication with a base station, and identifies, through an output signal from detecting means 6, whether or not a user ear is in contact with a terminal. Upon identification of contact of the ear to the terminal, controlling means 8 are caused to stop the supply of electric power, from a power supply 7, to displaying means 9 for providing information to a user, and lighting means 10, such as a black light.”), ¶ 0005-0007 (“In the present invention, control is such that, upon determination that the wireless terminal is in a call, operation of functions believe be unnecessary, due to the user of the terminal being in a call, is stopped, and upon termination of the call,

operation of the stopped functions is restarted. Additionally, because it is envisioned that there will also be cases where, even during a call, the face of the user may be separated from the receiver of the terminal, control is performed so as to enable restarting of the operations of the functions that had been stopped as unnecessary, through detecting whether or not the user of the terminal has the receiver in contact with an ear. The achievement of reduced power consumption through stopping operation of functions that become unnecessary in use of the terminal, as described above, can be anticipated to have the effect of extending the life of the power supply, such as a battery.”); Fukiharu 598 at ¶ 0018 (“The present invention, through the use of a structure as described above, enables a reduction in the consumption of battery power, through enabling the lighting devices to be turned OFF when the ear is caused to contact the receiver portion in order to hear the receiver sound during voice communications of a mobile telephone when the lighting devices (backlights) for a liquid crystal display device and keypad portion of a mobile telephone are lit, such as that night.”). A person of ordinary skill in the art at the time of the alleged invention would be motivated to modify Numazawa to have “the proximity sensor begin[] detecting whether an external object is proximate substantially concurrently with the mobile station initiating an outgoing wireless telephone call or receiving an incoming wireless telephone call” as disclosed in Fukiharu 598 because the proximity sensor does not need to be detecting when its output is not being monitored, and beginning detecting only during the period when the signal is being monitored would save additional power. The combination would constitute, at least, combining prior art elements according to known methods to yield predictable results, a simple substitution of one known element for another to obtain predictable results, the use of a known technique to improve similar devices in the same way, the application of a known technique to a known device ready for improvement to yield a predictable result, and obvious to try.

To the extent Numazawa is deemed to not expressly or inherently disclose “the proximity sensor begins detecting whether an external object is proximate substantially concurrently with the mobile station initiating an outgoing wireless telephone call or receiving an incoming wireless telephone call,” it would be obvious to combine the

disclosure of Numazawa with those of Miyashita as described in the Miyashita claim chart, which is incorporated herein in its entirety by reference. Numazawa and Miyashita are both directed to conserving battery power in mobile stations generally and more particularly at conserving battery power in mobile stations by using sensors to detect when the user of the mobile station is in a call and unlikely to be looking at the display (as when, for example, the proximity sensor detects the user's ear by the mobile station or a sensor detects that the mobile station is in a vertical orientation) and to power off the display of mobile stations at such times. Numazawa at ¶ Abstract (“To achieve reduced power consumption through stopping operation of unnecessary functions during use of a wireless terminal. A CPU 2 identifies start of a call state through a signal from a signal processing portion 3 for controlling communication with a base station, and identifies, through an output signal from detecting means 6, whether or not a user ear is in contact with a terminal. Upon identification of contact of the ear to the terminal, controlling means 8 are caused to stop the supply of electric power, from a power supply 7, to displaying means 9 for providing information to a user, and lighting means 10, such as a black light.”), ¶ 0005-0007 (“In the present invention, control is such that, upon determination that the wireless terminal is in a call, operation of functions believe be unnecessary, due to the user of the terminal being in a call, is stopped, and upon termination of the call, operation of the stopped functions is restarted. Additionally, because it is envisioned that there will also be cases where, even during a call, the face of the user may be separated from the receiver of the terminal, control is performed so as to enable restarting of the operations of the functions that had been stopped as unnecessary, through detecting whether or not the user of the terminal has the receiver in contact with an ear. The achievement of reduced power consumption through stopping operation of functions that become unnecessary in use of the terminal, as described above, can be anticipated to have the effect of extending the life of the power supply, such as a battery.”); Miyashita at 3:58-4:2 (“In contrast, the display control portion 17 is responsive to the inclination angle information indicative of variation of the inclination angle from the substantially horizontal orientation to the substantially vertical orientation while it performs display control for the display portion 16 to display the control information, to terminate the power supply for the display portion 16. When speaking is performed with the destination person via the speaker 12 and the microphone 14, it is rare to require seeing the display content on the display portion 16. Therefore, the power supply for the display portion 16 is shut

	<p>down. Thus, exhausting of a battery can be reduced.’’). While Miyashita discloses a gyro, it would be obvious to one of ordinary skill in the art at the time of the alleged invention to make Numazawa’s proximity sensor to function in the same way as the gyro in Miyashita as both sensors serve the same function (to serve as an indication that the mobile station’s display is unlikely to be viewed and can therefore be powered off). A person of ordinary skill in the art at the time of the alleged invention would therefore be motivated to modify Numazawa to have “the proximity sensor begin[] detecting whether an external object is proximate substantially concurrently with the mobile station initiating an outgoing wireless telephone call or receiving an incoming wireless telephone call” as disclosed in Miyashita because the proximity sensor does not need to be detecting when its output is not being monitored, and beginning detecting only during the period when the signal is being monitored would save additional power. The combination would constitute, at least, combining prior art elements according to known methods to yield predictable results, a simple substitution of one known element for another to obtain predictable results, the use of a known technique to improve similar devices in the same way, the application of a known technique to a known device ready for improvement to yield a predictable result, and obvious to try.</p>
<p>[Claim 2] The mobile station of claim 1, wherein the microprocessor reduces power to the display only if (i) the microprocessor determines that a telephone call is active and (ii) the signal indicates the proximity of the external object.</p>	<p>Numazawa discloses the microprocessor reducing power to the display only if (i) the microprocessor determines that a telephone call is active and (ii) the signal indicates the proximity of the external object.</p> <p>For example:</p> <p><i>See</i> discussion of claim element [1h], <i>supra</i>, which is incorporated herein by reference.</p>
<p>[Claim 4] The mobile station as recited in claim 1, wherein the microprocessor reduces power to the display by turning off the display.</p>	<p>Numazawa discloses the microprocessor reducing power to the display by turning off the display.</p>

For example:

See discussion of claim element [1f], *supra*, which is incorporated herein by reference.

“A CPU 2 identifies start of a call state through a signal from a signal processing portion 3 for controlling communication with a base station, and identifies, through an output signal from detecting means 6, whether or not a user ear is in contact with a terminal. Upon identification of contact of the ear to the terminal, controlling means 8 are caused to stop the supply of electric power, from a power supply 7, to displaying means 9 for providing information to a user, and lighting means 10, such as a black light.” Numazawa at Abstract.

“Following this, in Step S4, the CPU 2 outputs, to the controlling means 8, a signal for stopping the displaying means 9 and the lighting means 10. Through this, the controlling means 8 stop the supply of power from the power supply 7 to the displaying means 9 and the lighting means 10, and the displaying means 9 and lighting means 10 stop operating.” Numazawa at ¶ 0021.

“Next, in Step S9, the CPU 2, in order to again stop the displaying means 9 and the lighting means 10, outputs, to the controlling means 8, a signal to stop the displaying means 9 and the lighting means 10. Through this, the controlling means 8 stop the supply of power from the power supply 7 to the displaying means 9 and the lighting means 10, to thereby stop operation of the displaying means 9 and the lighting means 10.” Numazawa at ¶ 0025.

“

FIG. 2

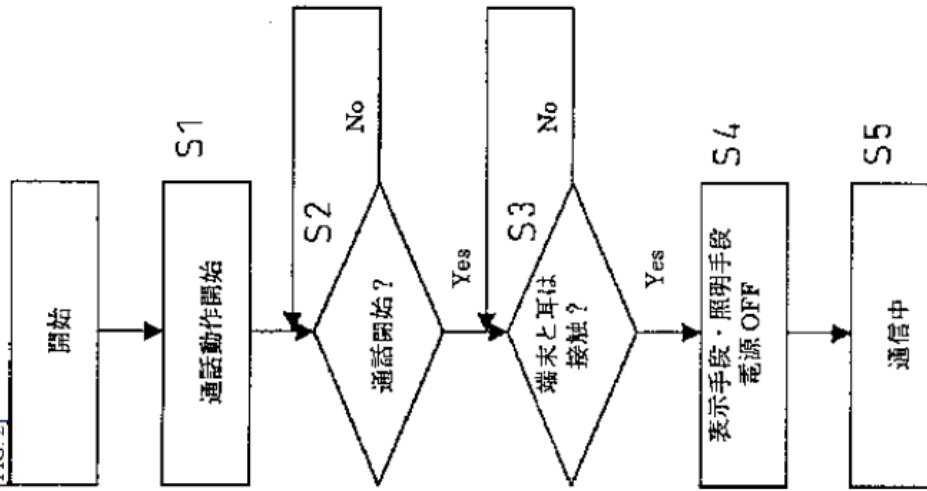

[TOP] Start
S1: Begin Call Operation
S2: Call started?
S3: Terminal and ear in contact?
S4: Turn displaying means/lighting means power supply off.
S5: In Call

»

Numazawa at Fig. 2.

“

[FIG. 3]

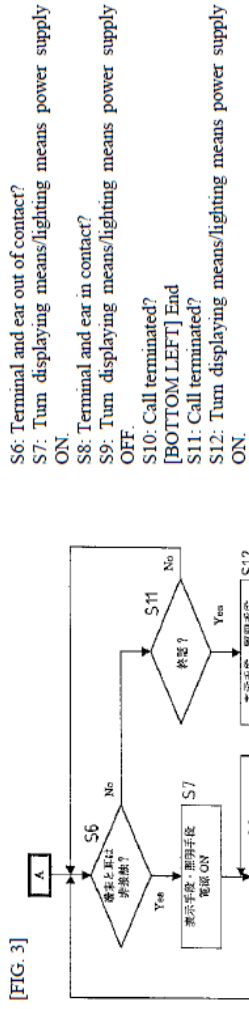

”

Numazawa at Fig. 3.

[Claim 5] The mobile station as recited in claim 1, wherein the proximity sensor is a mechanical proximity sensor, an optical proximity sensor, an optical sensor, or a range-detecting sensor.

Numazawa discloses that the proximity sensor is a mechanical proximity sensor, an optical sensor, or a range-detecting sensor.

For example:

“A CPU 2 identifies start of a call state through a signal from a signal processing portion 3 for controlling communication with a base station, and identifies, through an output signal from detecting means 6, whether or not a user ear is in contact with a terminal. Upon identification of contact of the ear to the terminal, controlling means 8 are caused to stop the supply of electric power, from a power supply 7, to displaying means 9 for providing information to a user, and lighting means 10, such as a black light.” Numazawa at Abstract.

“In the invention set forth in Claim 6, during a call, whether operation of a function is necessary or not is evaluated through whether or not the receiver is in contact with the ear of the user, and thus there is the effect of being able to start operation of a function immediately when it becomes necessary to start the operation of a function that has been stopped, when the receiver is removed from the ear of the user, even when in a call state.” Numazawa at ¶ 0014.

“FIG. 1 depicts the structure of a wireless terminal in one embodiment according to the present invention, wherein: . . . 6 is detecting means for detecting whether or not the user of the terminal has contacted his/her ear to the terminal . . .” Numazawa at ¶ 0016.

“When the CPU 2 identifies, through an input signal from the signal processing portion 3, that the call mode has been started, it evaluates, through an input signal from the detecting means 6, whether or not the user has brought the terminal into contact with his or her ear. Upon determination that the user of the terminal has brought the terminal into contact with the ear, the CPU 2 causes the controlling means 8 to stop the supply of power from the power supply 7, to stop operation of the displaying means 9 and the lighting means 10.” Numazawa at ¶ 0017.

“A reduced power consumption controlling method for a wireless terminal as set forth in any of Claim 1 through 5, wherein: during a call, whether the operation of functions such as displaying means, lighting means, or the like, of a wireless terminal should be stopped or caused to operate is evaluated through detecting contact or non-contact between a receiver and an ear of a user.” Numazawa at Claim 6.

To the extent Numazawa is deemed to not expressly disclose “the proximity sensor is a mechanical proximity sensor, an optical sensor, or a range-detecting sensor,” Numazawa inherently discloses this limitation. In Numazawa, the detecting means is able to detect whether the user has contacted his or her ear to the terminal. A person of ordinary skill in the art at the time of the alleged invention would understand that detecting this contact is necessarily accomplished by mechanical proximity sensor. Thus, a person of ordinary skill in the art at the time of the alleged invention would understand Numazawa to inherently disclose “the proximity sensor is a mechanical proximity sensor, an optical sensor, or a range-detecting sensor.”

To the extent Numazawa is deemed to not expressly or inherently disclose “the proximity sensor is a mechanical proximity sensor, an optical sensor, or a range-detecting sensor,” Numazawa renders it obvious to one of skill in the art to use a mechanical proximity sensor. A person of ordinary skill in the art at the time of the alleged invention would be aware of “conventional mechanical proximity (load) sensors,” which the ’889 Patent identifies as known prior art. See ’889 Patent at 3:15-20. A person of ordinary skill in the art at the time of the alleged invention would understand that a mechanical proximity sensor could be used to detect contact with the user. Using a mechanical proximity sensor would constitute, at least, combining prior art elements according to known methods to yield predictable results, a simple substitution of one known element for another to obtain predictable results, the use of a known technique to improve similar devices in the same way, the application of a

	<p>known technique to a known device ready for improvement to yield a predictable result, and obvious to try.</p>
<p>[Claim 6] The mobile station as recited in claim 1, wherein the proximity sensor is located proximate to the display.</p>	<p>Numazawa discloses that the proximity sensor is located proximate to the display.</p> <p>For example:</p> <p>“On the other hand, in a conventional wireless terminal, electric power is consumed unnecessarily during the interval between when the power supply is started and the power supply is cut, through the function for displaying text, and the like, operating constantly, regardless the mode of the wireless terminal and the state of the user.” Numazawa at ¶ 0003.</p> <p>“Moreover, stopping the operation of unnecessary functions can be anticipated to have the effect of reducing burnout of the light emitting components, such as LEDs, used in the backlight, or the like, and of reducing burn-in of display devices, such as LCDs, used for performing those functions.” Numazawa at ¶ 0008.</p> <p>“In the invention set forth in Claim 2, in a wireless terminal that has displaying means such as for communicating, to the user, information such as displaying the time or indicating the operating mode of the terminal, through functions such as a text display, illumination of an LED, or the like, an evaluation is performed as to whether or not in a call, and if in a call, the display on the displaying means, which is believed to not be visible, is stopped, and when the call is terminated, the display on the displaying means that has been stopped is restarted, so there is the effect of reducing unnecessary power</p>

consumption during a call, and the effect of reducing burnout of components used in the displaying means.” Numazawa at ¶ 0010.

“In the invention set forth in Claim 3, in a state wherein the display on the displaying means is stopped due to being in a call, an evaluation is performed as to whether or not the display on the displaying means is necessary, and if the evaluation is that it is necessary, the display on the displaying means that was stopped is restarted, so there is the effect of performing the display as normal if the user of the terminal separates the receiver from his/her face in order to view the display.” Numazawa at ¶ 0011.

“FIG. 1 depicts the structure of a wireless terminal in one embodiment according to the present invention, wherein: 1 is a wireless terminal; 2 is a CPU for evaluating whether or not the wireless terminal is in a call state, whether or not the user has the receiver against his/her ear, etc., and for controlling switching means for starting and stopping the supply of power to the functional block; . . . 6 is detecting means for detecting whether or not the user of the terminal has contacted his/her ear to the terminal; . . .” Numazawa at ¶ 0016.

To the extent Numazawa is deemed to not expressly disclose “the proximity sensor is located proximate to the display,” Numazawa inherently discloses this limitation. Numazawa discloses that its invention cuts power to the display during a call when the user has the receiver against his or her ear because the display is an unnecessary function at this time, i.e., it is not visible. A person of ordinary skill in the art at the time of the alleged invention would understand that the display is not visible because the user’s head is against it and, if the detecting means is to detect this, it necessarily would be “located proximate to the display.” Thus, a person of ordinary skill in the art at the time of the alleged invention would understand Numazawa to inherently disclose that “the proximity sensor is located proximate to the display.”

To the extent Numazawa is deemed to not expressly or inherently disclose “the proximity sensor is located proximate to the display,” Numazawa renders it obvious to one of skill in the art to have “the proximity sensor . . . located proximate to the display.” It would be obvious to a person of ordinary skill in the art at the time of the alleged invention that “the proximity sensor is located proximate to the display” because, in this location, it can determine that the display is not visible because the user’s head is against it. This would constitute, at least, combining prior art elements according to known methods to yield predictable results, a simple substitution of one known element for another to obtain predictable results, the use of a known technique to improve similar devices in the same way, the application of a known technique to a known device ready for improvement to yield a predictable result, and obvious to try.

To the extent Numazawa is deemed to not expressly or inherently disclose “the proximity sensor is located proximate to the display,” it would be obvious to combine the disclosure of Numazawa with those of Fukiharu 598 as described in the Fukiharu 598 claim chart, which is incorporated herein in its entirety by reference. Numazawa and Fukiharu 598 are both directed to conserving battery power in mobile stations generally and more particularly at conserving battery power in mobile stations by using sensors to detect when the user of the mobile station is in a call and unlikely to be looking at the display (as when, for example, the proximity sensor detects the user’s ear by the mobile station) and to power off the display of mobile stations at such times. Numazawa at ¶ Abstract (“To achieve reduced power consumption through stopping operation of unnecessary functions during use of a wireless terminal. A CPU 2 identifies start of a call state through a signal from a signal processing portion 3 for controlling communication with a base station, and identifies, through an output signal from detecting means 6, whether or not a user ear is in contact with a terminal. Upon identification of contact of the ear to the terminal, controlling means 8 are caused to stop the supply of electric power, from a power supply 7, to displaying means 9 for providing information to a user, and lighting means 10, such as a black light.”), ¶ 0005-0007 (“In the present invention, control is such that, upon determination that the

	<p>wireless terminal is in a call, operation of functions believe be unnecessary, due to the user of the terminal being in a call, is stopped, and upon termination of the call, operation of the stopped functions is restarted. Additionally, because it is envisioned that there will also be cases where, even during a call, the face of the user may be separated from the receiver of the terminal, control is performed so as to enable restarting of the operations of the functions that had been stopped as unnecessary, through detecting whether or not the user of the terminal has the receiver in contact with an ear. The achievement of reduced power consumption through stopping operation of functions that become unnecessary in use of the terminal, as described above, can be anticipated to have the effect of extending the life of the power supply, such as a battery.”; Fukiharu 598 at ¶ 0018 (“The present invention, through the use of a structure as described above, enables a reduction in the consumption of battery power, through enabling the lighting devices to be turned OFF when the ear is caused to contact the receiver portion in order to hear the receiver sound during voice communications of a mobile telephone when the lighting devices (backlights) for a liquid crystal display device and keypad portion of a mobile telephone are lit, such as that night.”). A person of ordinary skill in the art at the time of the alleged invention would be motivated to modify Numazawa to have “the proximity sensor is located proximate to the display” as disclosed in Fukiharu 598 to determine that the display is not visible because the user’s head is against it. The combination would constitute, at least, combining prior art elements according to known methods to yield predictable results, a simple substitution of one known element for another to obtain predictable results, the use of a known technique to improve similar devices in the same way, the application of a known technique to a known device ready for improvement to yield a predictable result, and obvious to try.</p>
<p>[Claim 8 – Preamble] 8. A method of conserving battery power in a mobile station, comprising:</p>	<p>To the extent the preamble is construed as limiting, Numazawa discloses a method of conserving battery power in a mobile station:</p> <p>For example:</p>

	<p>See discussion of claim elements [1a] and 1[f], <i>supra</i>, which are incorporated herein by reference.</p> <p>The present invention relates to a reduced power consumption controlling method in a wireless terminal for reducing power consumption by stopping operation of unnecessary functions during a call. Numazawa at ¶ 0001.</p>
<p>[8a] detecting whether an external object is proximate;</p>	<p>Numazawa discloses detecting whether an external object is proximate.</p> <p>For example:</p> <p>See discussion of claim elements [1b] and 1[e], <i>supra</i>, which are incorporated herein by reference.</p> <p>FIG. 1 depicts the structure of a wireless terminal in one embodiment according to the present invention, wherein: 1 is a wireless terminal; 2 is a CPU for evaluating whether or not the wireless terminal is in a call state, whether or not the user has the receiver against his/her ear, etc., and for controlling switching means for starting and stopping the supply of power to the functional block; . . . 6 is detecting means for detecting whether or not the user of the terminal has contacted his/her ear to the terminal; . . . Numazawa at ¶ 0016.</p> <p>When the CPU 2 identifies, through an input signal from the signal processing portion 3, that the call mode has been started, it evaluates, through an input signal from the detecting means 6, whether or not the user has brought the terminal into contact with his or her ear. Numazawa at ¶ 0017.</p> <p>In Step S3, the output signal from the detecting means 6 is monitored in order to detect whether the user of the wireless terminal has brought the terminal to the ear in</p>

the attitude of a call. In this case, when it has been identified, from the output signal from the detecting means 6, that the terminal is in contact with the ear of the user, processing advances to Step S4. Moreover, if it is identified, from the output signal from the detecting means 6, that the terminal is not in contact with the ear of the user, Step S3 is repeated. Numazawa at ¶ 0020.

Next, referencing FIG. 3, in Step S6 the CPU 2 monitors the output signal from the detecting means 6 in order to detect whether or not a call is in progress and the user has the terminal in the attitude of a call. When, in this case, it is identified, from the output signal from the detecting means 6, that the terminal has been separated from the ear of the user, processing advances to Step S7. If the CPU 2 identifies, from the output signal from the detecting means 6, that the terminal is still in contact with the ear of the user, processing advances to Step S11. Numazawa at ¶ 0022.

Following this, in Step S8, the CPU 2 monitors the output signal from the detecting means 6 to detect whether or not the user of the terminal has again gone into the attitude of a call. In this case, when the CPU 2 identifies, from the output signal from the detecting means 6, that the terminal is in contact with the ear of the user, processing advances to Step S9. Moreover, if it is identified, from the output signal from the detecting means 6, that the terminal is not in contact with the ear of the user, processing advances to Step S10. Numazawa at ¶ 0024.

[FIG. 1]

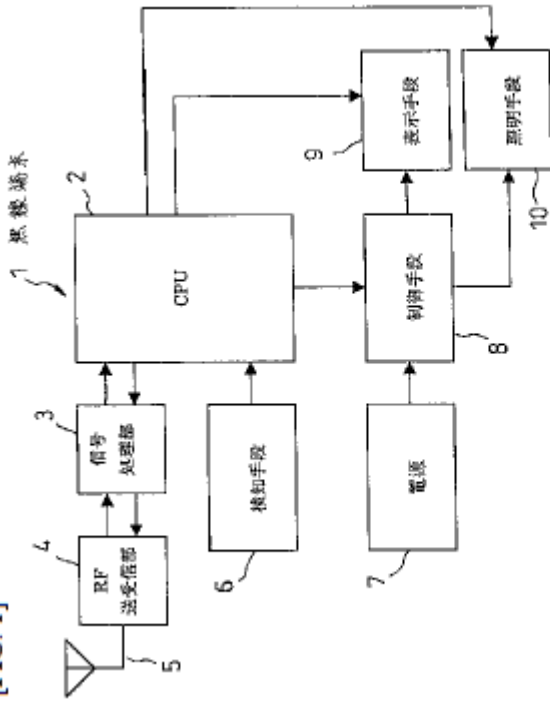

- 4: RF Transceiving Portion
- 3: Signal Processing Portion
- 1: Wireless Terminal
- 6: Detecting Means
- 7: Power Supply
- 8: Controlling Means
- 9: Displaying Means
- 10: Lighting Means

FIG. 2

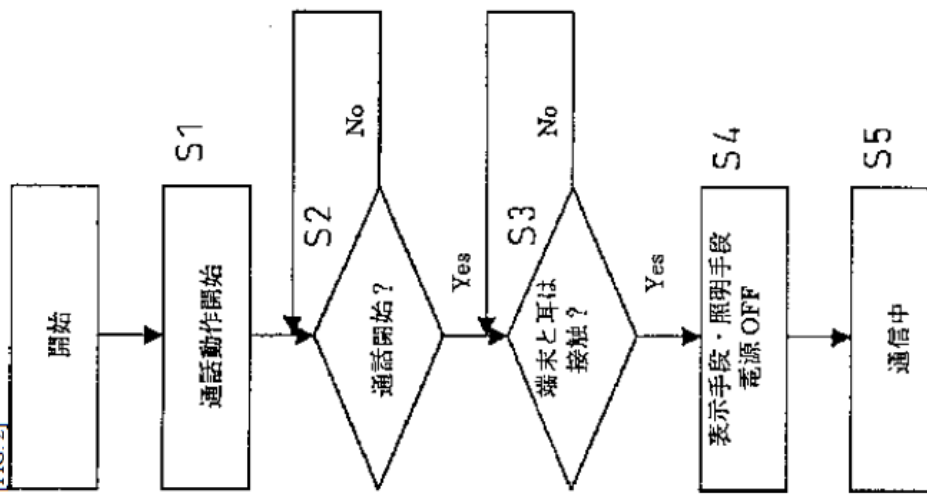

[TOP] Start
S1: Begin Call Operation
S2: Call started?
S3: Terminal and ear in contact?
S4: Turn displaying means/lighting means power supply off.
S5: In Call

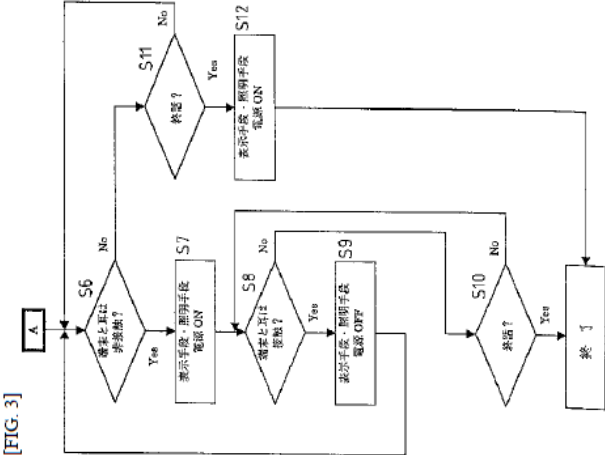
	<p>[FIG. 3]</p>  <p>S6: Terminal and ear out of contact? S7: Turn displaying means/lighting means power supply ON. S8: Terminal and ear in contact? S9: Turn displaying means/lighting means power supply OFF. S10: Call terminated? [BOTTOM LEFT] End S11: Call terminated? S12: Turn displaying means/lighting means power supply ON.</p>
<p>[8b] determining whether a telephone call is active; and</p>	<p>Numazawa discloses determining whether a telephone call is active.</p> <p>For example:</p> <p>See discussion of claim element [1d], <i>supra</i>, which is incorporated herein by reference.</p>
<p>[8c] reducing power consumption of a display of the mobile station if (i) a telephone call is determined to be active and (ii) the proximity of the external object is detected; wherein:</p>	<p>Numazawa discloses reducing power consumption of a display of the mobile station if (i) a telephone call is determined to be active and (ii) the proximity of the external object is detected.</p> <p>For example:</p>

	<p>See discussion of claim element [1f], <i>supra</i>, which is incorporated herein by reference.</p>
<p>[8d] the telephone call is a wireless telephone call;</p>	<p>Numazawa discloses that the telephone call is a wireless telephone call.</p> <p>For example:</p> <p>See discussion of claim element [1g], <i>supra</i>, which is incorporated herein by reference.</p>
<p>[8e] the power consumption of the display is reduced while the proximity of the external object is detected only if the wireless telephone call is determined to be active; and</p>	<p>Numazawa discloses that the power consumption of the display is reduced while the proximity of the external object is detected only if the wireless telephone call is determined to be active.</p> <p>For example:</p> <p>See discussion of claim element [1h], <i>supra</i>, which is incorporated herein by reference.</p>
<p>[8f] detecting whether an external object is proximate begins substantially concurrently with the mobile station initiating an outgoing wireless telephone call or receiving an incoming wireless telephone call.</p>	<p>Numazawa discloses that detecting whether an external object is proximate begins substantially concurrently with the mobile station initiating an outgoing wireless telephone call or receiving an incoming wireless telephone call.</p> <p>For example:</p> <p>See discussion of claim element [1i], <i>supra</i>, which is incorporated herein by reference.</p> <p>To the extent Numazawa is deemed to not expressly disclose this claim limitation, Numazawa inherently discloses this limitation. See discussion of claim element [1i], <i>supra</i>, which is incorporated herein by reference.</p> <p>To the extent Numazawa is deemed to not expressly or inherently disclose this claim limitation, Numazawa renders it obvious to one of skill in the art at the time of the</p>

	<p>alleged invention. <i>See</i> discussion of claim element [1i], <i>supra</i>, which is incorporated herein by reference.</p> <p>To the extent Numazawa is deemed to not expressly or inherently disclose this claim element, it would be obvious to combine the disclosure of Numazawa with those of Fukiharu 598 as described in the Fukiharu 598 claim chart, which is incorporated herein in its entirety by reference. <i>See</i> discussion of claim element [1i], <i>supra</i>, which is incorporated herein by reference.</p> <p>To the extent Numazawa is deemed to not expressly or inherently disclose this claim limitation, it would be obvious to combine the disclosure of Numazawa with those of Miyashita as described in the Miyashita claim chart, which is incorporated herein in its entirety by reference. <i>See</i> discussion of claim element [1i], <i>supra</i>, which is incorporated herein by reference.</p>
<p>[Claim 12] The method as recited in claim 8, wherein the detecting of the proximity of the external object is performed by a mechanical proximity sensor, an optical sensor, or a range-detecting sensor.</p>	<p>Numazawa discloses that the detecting of the proximity of the external object is performed by a mechanical proximity sensor, an optical sensor, or a range-detecting sensor.</p> <p>For example:</p> <p><i>See</i> discussion of Claim 5, <i>supra</i>, which is incorporated herein by reference.</p> <p>To the extent Numazawa is deemed to not expressly disclose this claim limitation, Numazawa inherently discloses this limitation. <i>See</i> discussion of claim 5, <i>supra</i>, which is incorporated herein by reference.</p> <p>To the extent Numazawa is deemed to not expressly or inherently disclose this claim limitation, Numazawa renders it obvious to one of skill in the art at the time of the alleged invention. <i>See</i> discussion of claim 5, <i>supra</i>, which is incorporated herein by reference.</p>

To the extent Numazawa is deemed to not expressly or inherently disclose this claim element, it would be obvious to combine the disclosure of Numazawa with those of Fukiharu 598 as described in the Fukiharu 598 claim chart, which is incorporated herein in its entirety by reference. *See* discussion of claim claim 5, *supra*, which is incorporated herein by reference.

To the extent Numazawa is deemed to not expressly or inherently disclose this claim limitation, it would be obvious to combine the disclosure of Numazawa with those of Miyashita as described in the Miyashita claim chart, which is incorporated herein in its entirety by reference. *See* discussion of claim claim 5, *supra*, which is incorporated herein by reference.

Exhibit A3

**Exhibit #A3 - Miyashita
to Defendants' Preliminary Invalidity Contentions**

**Invalidity Chart for U.S. Patent No. 7,319,889
U.S. Patent No. 5,586,182 (“Miyashita”)**

U.S. Patent No. 5,586,182 to Miyashita (“Miyashita”) was filed on May 1, 1995 and issued on December 17, 1996. Miyashita is prior art to the '889 Patent under at least pre-AIA 35 U.S.C. § 102(e). Miyashita anticipates or renders obvious, alone or in combination with other prior art references, each of the Asserted Claims of the '889 Patent as described in the chart below and in the main invalidity contentions document to which this chart is annexed.

It would have been obvious under 35 U.S.C. § 103 to a person having ordinary skill in the art at the time of the alleged invention to combine the teachings of Miyashita with the following references:

1. Japanese Unexamined Patent Application Publication No. H11-220432 (“Numazawa”). Numazawa qualifies as prior art under at least pre-AIA §§ 102(a), 102(b), and 102(e). Numazawa was published on August 10, 1999.
2. U.S. Patent No. 5,010,566 to Seo (“Seo”). Seo qualifies as prior art under at least pre-AIA 35 U.S.C. §§ 102(a), 102(b), and 102(e). Seo was filed on September 7, 1989 and issued on April 23, 1991.
3. US. Patent Application Publication No. 2004/0225904 A1 to Perez et al. (“Perez”). Perez qualifies as prior art under at least pre-AIA § 102(e). Perez was filed on May 6, 2003 and published on November 11, 2004.

<u>Asserted Claims</u>	<u>Corresponding Disclosure in the Prior Art Reference(s)</u>
[Claim 1 – Preamble] 1. A mobile station, comprising:	<p>Miyashita discloses a mobile station:</p> <p>For example:</p> <p>“For a portable telephone set having a display portion for displaying various information associated with call or origination and reception, a gyro for detecting inclination of a main body is provided.” Miyashita at Abstract.</p>

“The present invention relates to a pocket telephone or portable telephone set. More specifically, the invention relates to a portable telephone set which has a display for displaying various information associated with call origination and reception.”
Miyashita at 1:6-10.

“According to one aspect of the invention, a portable telephone set comprises:
a display device for displaying information associated with a call;
a detector apparatus for detecting the orientation a main body, in which the display means is built-in; and
a control apparatus for controlling power supply for the display depending upon the orientation detected by the detector.”

Miyashita at 1:64-2:5.

FIG. 3

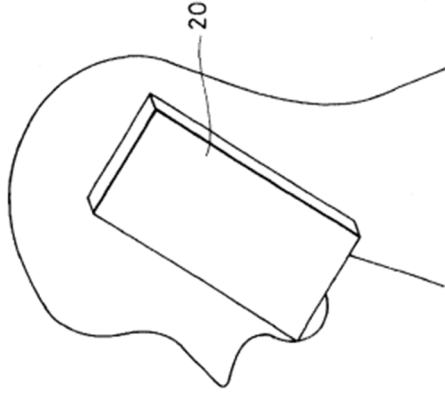
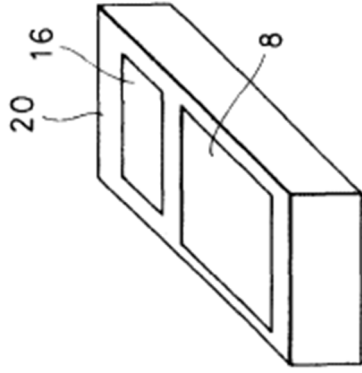

FIG. 2



Miyashita at Figs. 2, 3.

“FIG. 2 is an illustration showing inclination of the main body a during a dialing operation for the one embodiment of a portable telephone set according to the invention, and FIG. 3 is an illustration showing inclination of the main body during speaking and not out-dialing for the one embodiment of portable set according to the invention.” Miyashita at 4:3-8.

[1a] a display;

Miyashita discloses a display:

For example:

“For a portable telephone set having a display portion for displaying various information associated with call or origination and reception, a gyro for detecting inclination of a main body is provided.” Miyashita at Abstract.

“The present invention relates to a pocket telephone or portable telephone set. More specifically, the invention relates to a portable telephone set which has a display for displaying various information associated with call origination and reception.” Miyashita at 1:6-10.

“According to one aspect of the invention, a portable telephone set comprises: a display device for displaying information associated with a call;”

Miyashita at 1:64-67.

“FIG. 1 is a block diagram showing a construction of one embodiment of the portable telephone set according to the present invention. FIG. 1, encompasses one embodiment of the portable telephone set according to the invention with substantially the same construction as FIG. 4 except for a display portion 16, a display control portion 17 and a gyro 18 as additional components.” Miyashita at 3:27-33.

FIG. 1

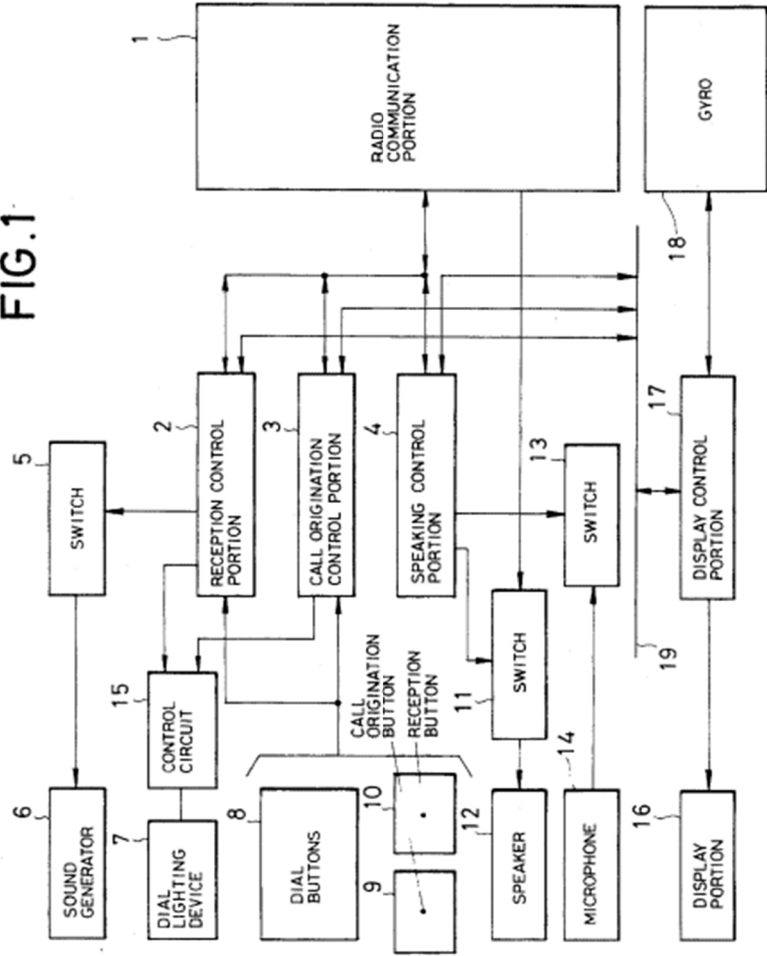

Miyashita at Fig. 1.

“In FIG. 2 when the dial buttons 8 of the portable telephone set are to be operated, the main body 20 should be held in substantially horizontal orientation, directing dial buttons 8 and the display portion 16 upwardly.” Miyashita at 4:9-12.

FIG. 2

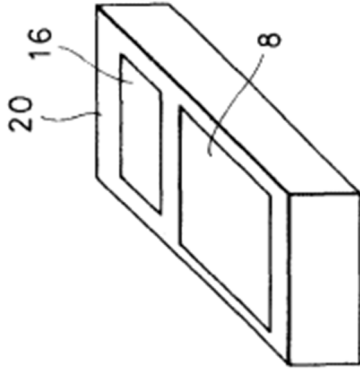

Miyashita at Fig. 2.

“What is claimed is:

1. A portable telephone set comprising:
display for displaying information associated with a call . . .”

Miyashita at Claim 1.

[1b] a proximity sensor adapted to generate a signal indicative of proximity of an external object; and

Miyashita discloses a proximity sensor adapted to generate a signal indicative of proximity of an external object:

For example:

“FIG. 1 is a block diagram showing a construction of one embodiment of the portable telephone set according to the present invention. FIG. 1, encompasses one

embodiment of the portable telephone set according to the invention with substantially the same construction as FIG. 4 except for a display portion 16, a display control portion 17 and a gyro 18 as additional components.” Miyashita at 3:27-33.

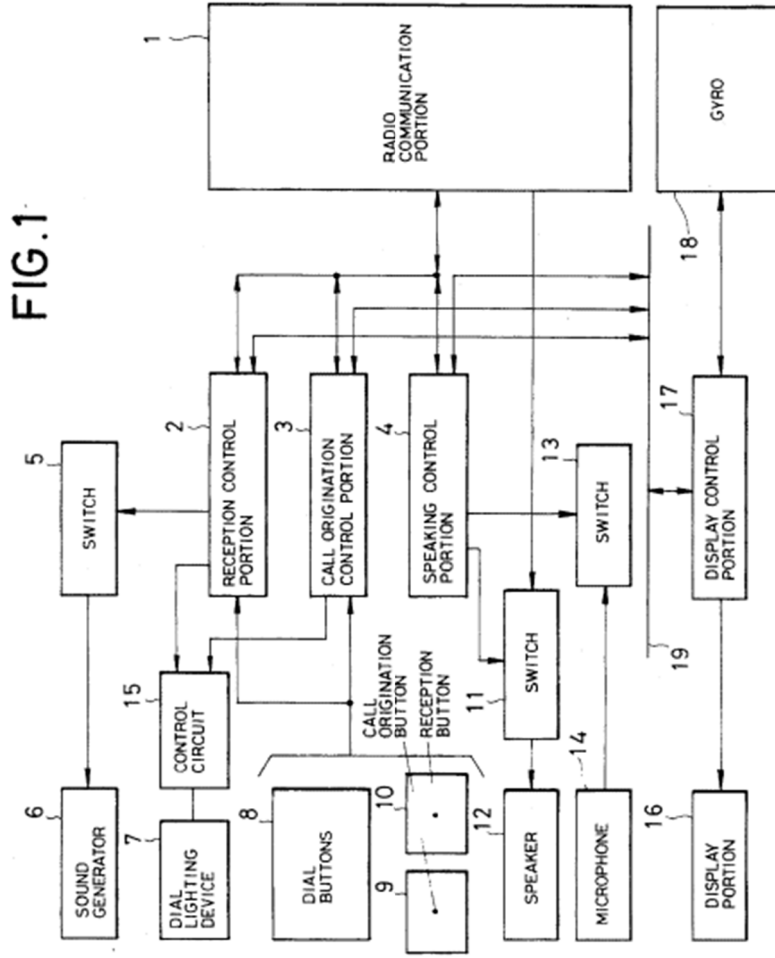

Miyashita at Fig. 1.

“The gyro 18 detects an inclination of a main body the portable telephone set to provide information concerning an inclination angle to the display control portion 17.

The display control portion 17 receives the inclination angle information from the gyro 18. The display control portion 17 is responsive to the inclination angle information indicative of a substantially horizontal orientation of the main body and to one of reception control command from the reception control portion 2 and a call origination control command from the call origination control portion 3, to control a power source to supply a power to the display portion 16.

In contrast, the display control portion 17 is responsive to the inclination angle information indicative of variation of the inclination angle from the substantially horizontal orientation to the substantially vertical orientation while it performs display control for the display portion 16 to display the control information, to terminate the power supply for the display portion 16.” Miyashita at 3:46-64.

“In FIG. 2 when the dial buttons 8 of the portable telephone set are to be operated, the main body 20 should be held in substantially horizontal orientation, directing dial buttons 8 and the display portion 16 upwardly.

At this condition, when dial buttons 8, call origination button 9 and reception button 10 are selectively depressed, connection to the remote terminal is established for enabling speaking. During speaking, the main body 20 is held in substantially vertical orientation. The orientations of the main body 20 as illustrated in FIGS. 2 and 3, are detected by the gyro 18 and the inclination angle information is input to the display control portion 17, as set forth above.

Therefore, as set forth above, the display control portion 17 performs the power supply control so the power is supplied to the display portion 16 when the main body is placed at the substantially horizontal orientation as detected by the gyro 18. On the other hand, when the gyro 18 detects the fact that the main body is placed at substantially vertical orientation, the display control portion 17 shut down the power supply for the display portion 16.” Miyashita at 4:9-29.

“It should be appreciated that the wording “substantially horizontal orientation” as defined throughout the disclosure represents the position of the main body where the dial button array, call origination button, reception button and display portion face toward the user’s face, which may not be necessarily exactly horizontal, but instead is over relatively wider range of orientation; and the wording “substantially vertical orientation” as defined throughout the disclosure represents the position of the main body where the dial button array, call origination button, reception button and display portion are placed substantially perpendicular to the plane facing with the user’s face, which is not necessarily exactly vertical but instead is over a relatively wide range but the position where the speaker is placed in opposition to the user’s ear and the microphone is placed in the vicinity of the user’s mouth.” Miyashita at 4:46-61.

To the extent Miyashita is deemed to not expressly disclose “a proximity sensor adapted to generate a signal indicative of proximity of an external object,” Miyashita inherently discloses this limitation. Miyashita discloses a gyro that indicates the inclination angle (vertical vs. horizontal) of the mobile station for the purpose of indicating whether a user is likely looking or not looking at the display of the mobile station and/or talking on the mobile station. *See* Miyashita at 3:46-4:2 (“The gyro 18 detects an inclination of a main body the portable telephone set to provide information concerning an inclination angle to the display control portion 17. The display control portion 17 receives the inclination angle information from the gyro 18. The display control portion 17 is responsive to the inclination angle information indicative of a substantially horizontal orientation of the main body and to one of reception control command from the reception control portion 2 and a call origination control command from the call origination control portion 3, to control a power source to supply a power to the display portion 16. In contrast, the display control portion 17 is responsive to the inclination angle information indicative of variation of the inclination angle from the substantially horizontal orientation to the substantially vertical orientation while it performs display control for the display portion 16 to display the control information, to terminate the power supply for the display portion 16. When speaking is performed

with the destination person via the speaker 12 and the microphone 14, it is rare to require seeing the display content on the display portion 16. Therefore, the power supply for the display portion 16 is shut down. Thus, exhausting of a battery can be reduced.’). A person of ordinary skill in the art at the time of the alleged invention would have understood that various sensors can be used in a mobile station for the purpose of indicating whether a user is likely looking or not looking at the display of the mobile station and/or talking on the mobile station. *See, e.g.,* Perez at ¶ 0022 (“[T]he step of detecting a talk condition can be achieved by monitoring or detecting at least one among the conditions of a) detecting if a predetermined volume of acoustic sound is being received at a microphone indicative of a user talking on the portable communication device; b) measuring at least one among a spectrum density and a spectrum energy of a bounced signal to determine the proximity of a user’s head to an earpiece of the portable communication device; c) measuring a predetermined period after a phone call starts; d) detecting an angle at which the portable communication device is positioned; e) detecting a vibration of the portable communication device; or f) detecting if the portable communication device is in a user’s hand. How the method 50 can detect the conditions described above can be embodied in many different forms using individually or in combination sensors and timers and other devices”). A person of ordinary skill in the art at the time of the alleged invention would therefore have understood that the invention of Miyashita could be performed using a “a proximity sensor adapted to generate a signal indicative of proximity of an external object” for the purpose of indicating whether a user is likely looking or not looking at the display of the mobile station and/or talking on the mobile station. Miyashita therefore necessarily discloses “a proximity sensor adapted to generate a signal indicative of proximity of an external object.”

To the extent Miyashita is deemed to not expressly or inherently disclose “a proximity sensor adapted to generate a signal indicative of proximity of an external object,” Miyashita renders it obvious to one of ordinary skill in the art at the time of the alleged invention to use “a proximity sensor adapted to generate a signal indicative of proximity of an external object.” Miyashita discloses a gyro that indicates the inclination angle (vertical vs. horizontal) of the mobile station for the purpose of

indicating whether a user is likely looking or not looking at the display of the mobile station and/or talking on the mobile station. *See* Miyashita at 3:46-4:2 (“The gyro 18 detects an inclination of a main body the portable telephone set to provide information concerning an inclination angle to the display control portion 17. The display control portion 17 receives the inclination angle information from the gyro 18. The display control portion 17 is responsive to the inclination angle information indicative of a substantially horizontal orientation of the main body and to one of reception control command from the reception control portion 2 and a call origination control command from the call origination control portion 3, to control a power source to supply a power to the display portion 16. In contrast, the display control portion 17 is responsive to the inclination angle information indicative of variation of the inclination angle from the substantially horizontal orientation to the substantially vertical orientation while it performs display control for the display portion 16 to display the control information, to terminate the power supply for the display portion 16. When speaking is performed with the destination person via the speaker 12 and the microphone 14, it is rare to require seeing the display content on the display portion 16. Therefore, the power supply for the display portion 16 is shut down. Thus, exhausting of a battery can be reduced.”). A person of ordinary skill in the art at the time of the alleged invention would have understood that various sensors can be used in a mobile station for the purpose of indicating whether a user is likely looking or not looking at the display of the mobile station and/or talking on the mobile station. *See, e.g.,* Perez at ¶ 0022 (“[T]he step of detecting a talk condition can be achieved by monitoring or detecting at least one among the conditions of a) detecting if a predetermined volume of acoustic sound is being received at a microphone indicative of a user talking on the portable communication device; b) measuring at least one among a spectrum density and a spectrum energy of a bounced signal to determine the proximity of a user’s head to an earpiece of the portable communication device; c) measuring a predetermined period after a phone call starts; d) detecting an angle at which the portable communication device is positioned; e) detecting a vibration of the portable communication device; or f) detecting if the portable communication device is in a user’s hand. How the method 50 can detect the conditions described above can be embodied in many different forms using individually or in combination sensors and timers and other devices”). A person of ordinary skill in the art at the time of the alleged invention would therefore have understood that the invention of Miyashita could be performed using a “a proximity

sensor adapted to generate a signal indicative of proximity of an external object' for the purpose of indicating whether a user is likely looking or not looking at the display of the mobile station and/or talking on the mobile station. Doing so would be a design choice driven by a number of different reasons and would be within the knowledge and ability of a person of ordinary skill in the art at the time of the alleged invention. This combination would constitute, at least, combining prior art elements according to known methods to yield predictable results, a simple substitution of one known element for another to obtain predictable results, the use of a known technique to improve similar devices in the same way, the application of a known technique to a known device ready for improvement to yield a predictable result, and obvious to try.

To the extent Miyashita is deemed to not expressly or inherently disclose "a proximity sensor adapted to generate a signal indicative of proximity of an external object," it would be obvious to combine the disclosure of Miyashita with those of Numazawa as described in the Numazawa claim chart, which is incorporated herein in its entirety by reference. Miyashita and Numazawa are both directed to conserving battery power in mobile stations generally and more particularly at conserving battery power in mobile stations by using sensors to detect when the user of the mobile station is in a call and unlikely to be looking at the display (as when, for example, the proximity sensor detects the user's ear by the mobile station or a sensor detects that the mobile station is in a vertical orientation) and to power off the display of mobile stations at such times. Miyashita at 1:58-63 ("The present invention is directed to solving the problem set forth above. It is therefore an object of the present invention to provide a portable telephone set which can shut off the power supply for a display portion while a content of the display will not be seen during speaking, and thus can reduce power consumption."), 2:6-11 ("In the preferred construction the detector is a gyro. The control apparatus may shut off the power supply for the display when the detector detects the main body at a substantially vertical position. On the other hand, the control may initiate power supply for the display when the detector detects the main body at a substantially horizontal position."); Numazawa at ¶ Abstract ("To achieve reduced power consumption through stopping operation of unnecessary functions during use of a wireless terminal. A CPU 2 identifies start of a call state through a signal

from a signal processing portion 3 for controlling communication with a base station, and identifies, through an output signal from detecting means 6, whether or not a user ear is in contact with a terminal. Upon identification of contact of the ear to the terminal, controlling means 8 are caused to stop the supply of electric power, from a power supply 7, to displaying means 9 for providing information to a user, and lighting means 10, such as a black light.”), ¶ 0005-0007 (“In the present invention, control is such that, upon determination that the wireless terminal is in a call, operation of functions believe be unnecessary, due to the user of the terminal being in a call, is stopped, and upon termination of the call, operation of the stopped functions is restarted. Additionally, because it is envisioned that there will also be cases where, even during a call, the face of the user may be separated from the receiver of the terminal, control is performed so as to enable restarting of the operations of the functions that had been stopped as unnecessary, through detecting whether or not the user of the terminal has the receiver in contact with an ear. The achievement of reduced power consumption through stopping operation of functions that become unnecessary in use of the terminal, as described above, can be anticipated to have the effect of extending the life of the power supply, such as a battery.”). A person of ordinary skill in the art at the time of the alleged invention would be motivated to modify Miyashita to use “a proximity sensor adapted to generate a signal indicative of proximity of an external object,” as disclosed in Numazawa for a number of different reasons, including that it would support Miyashita’s ability to conserve battery power in mobile stations, and doing so would be within the knowledge and ability of a person of ordinary skill in the art at the time of the alleged invention. The combination would constitute, at least, combining prior art elements according to known methods to yield predictable results, a simple substitution of one known element for another to obtain predictable results, the use of a known technique to improve similar devices in the same way, the application of a known technique to a known device ready for improvement to yield a predictable result, and obvious to try.

To the extent Miyashita is deemed to not expressly or inherently disclose “a proximity sensor adapted to generate a signal indicative of proximity of an external object,” it would be obvious to combine the disclosure of Miyashita with those of Perez as

described in the Perez claim chart, which is incorporated herein in its entirety by reference. Miyashita and Perez are both directed to conserving battery power in mobile stations generally and more particularly at conserving battery power in mobile stations by using sensors to detect when the user of the mobile station is in a call and unlikely to be looking at the display (as when, for example, the proximity sensor detects the user's ear by the mobile station or a sensor detects that the mobile station is in a vertical orientation) and to power off the display of mobile stations at such times. Miyashita at 1:58-63 ("The present invention is directed to solving the problem set forth above. It is therefore an object of the present invention to provide a portable telephone set which can shut off the power supply for a display portion while a content of the display will not be seen during speaking, and thus can reduce power consumption."), 2:6-11 ("In the preferred construction the detector is a gyro. The control apparatus may shut off the power supply for the display when the detector detects the main body at a substantially vertical position. On the other hand, the control may initiate power supply for the display when the detector detects the main body at a substantially horizontal position."); Perez at ¶ 0013 ("Referring to FIG. 1, a portable communication product 10 such as a cellular phone includes a transceiver radio having a microphone 20, an earpiece 22, a keypad 18 and a display 12 (such as a color display) coupled to the transceiver radio. The portable communication product 10 further includes at least one sensor (24, 26, 28 or 30) and a processor 16. The sensor can be used for detecting a user condition of the portable communication device such as a talk condition when the user is assumed to be talking on the portable communication device. The processor 16 can be programmed to at least reduce power provided to the display 12 when the sensor detects the talk condition. The processor 16 can also turn off power to the display 12 during a talk condition if desired."). A person of ordinary skill in the art at the time of the alleged invention would be motivated to modify Miyashita to use "a proximity sensor adapted to generate a signal indicative of proximity of an external object," as disclosed in Perez for a number of different reasons, including that it would support Miyashita's ability to conserve battery power in mobile stations, and doing so would be within the knowledge and ability of a person of ordinary skill in the art at the time of the alleged invention. The combination would constitute, at least, combining prior art elements according to known methods to yield predictable results, a simple substitution of one known element for another to obtain predictable results, the use of a known technique to improve similar devices in the same way, the application of a

known technique to a known device ready for improvement to yield a predictable result, and obvious to try.

To the extent Miyashita is deemed to not expressly or inherently disclose “a proximity sensor adapted to generate a signal indicative of proximity of an external object,” it would be obvious to combine the disclosure of Miyashita with those of Seo as described in the Seo claim chart, which is incorporated herein in its entirety by reference. Miyashita and Seo are both directed to conserving battery power in mobile stations generally and more particularly at conserving battery power in mobile stations by using sensors to detect when the user of the mobile station is in a call and unlikely to be looking at the display (as when, for example, the proximity sensor detects the user’s ear by the mobile station or a sensor detects that the mobile station is in a vertical orientation) and to power off the display of mobile stations at such times. Miyashita at 1:58-63 (“The present invention is directed to solving the problem set forth above. It is therefore an object of the present invention to provide a portable telephone set which can shut off the power supply for a display portion while a content of the display will not be seen during speaking, and thus can reduce power consumption.”), 2:6-11 (“In the preferred construction the detector is a gyro. The control apparatus may shut off the power supply for the display when the detector detects the main body at a substantially vertical position. On the other hand, the control may initiate power supply for the display when the detector detects the main body at a substantially horizontal position.”); Seo at 1:36-42 (“It is hence a primary object of the invention to present a novel cordless telephone capable of, by solving the above mentioned technical problems, stopping the display action by the display device while the handset is in service so as to minimize the wasteful consumption of the electric power supplied from the battery or the like.”), 3:64-4:5 (When the receiver 6 is not in contact with the user’s ear, the light emitting element 3 lights up at step n8. In this state, when the user touches the receiver 6 of the handset by the ear, it is detected by the piezoelectric element 7, and the detection signal is sent out to the control circuit 11. The control circuit 11, on the basis of this detection signal, sends out a stop signal to the driver 12. Thus, driving of the driver 12 is stopped, and the light emitting element 3 is extinguished at step n7.”). A person of ordinary skill in the art at the time of the

	<p>alleged invention would be motivated to modify Miyashita to use “a proximity sensor adapted to generate a signal indicative of proximity of an external object,” as disclosed in Seo for a number of different reasons, including that it would support Miyashita’s ability to conserve battery power in mobile stations, and doing so would be within the knowledge and ability of a person of ordinary skill in the art at the time of the alleged invention. The combination would constitute, at least, combining prior art elements according to known methods to yield predictable results, a simple substitution of one known element for another to obtain predictable results, the use of a known technique to improve similar devices in the same way, the application of a known technique to a known device ready for improvement to yield a predictable result, and obvious to try.</p>
<p>[1c] a microprocessor adapted to:</p>	<p>Miyashita discloses a microprocessor:</p> <p>For example:</p> <p>“FIG. 1 is a block diagram showing a construction of one embodiment of the portable telephone set according to the present invention. FIG. 1, encompasses one embodiment of the portable telephone set according to the invention with substantially the same construction as FIG. 4 except for a display portion 16, a display control portion 17 and a gyro 18 as additional components.” Miyashita at 3:27-33.</p>

FIG. 1

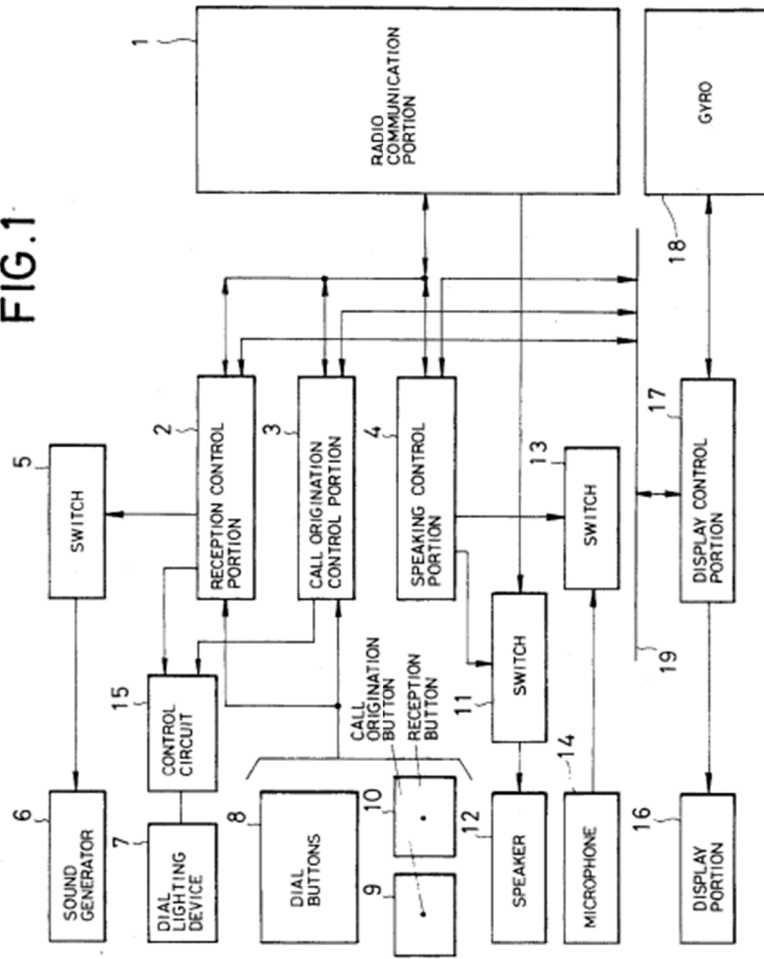

Miyashita at Fig. 1.

“The display control portion 17 is connected to a reception control portion 2, a call origination control portion 3 and a speaking control portion 4, respectively, via a common path 19. Control information associated with speaking is displayed on the display portion 16. On the other hand, the display control portion 17 also controls power supply for the display portion 16.” Miyashita at 3:39-46.

To the extent Miyashita is deemed to not expressly disclose a “microprocessor adapted to,” Miyashita inherently discloses this limitation. Miyashita discloses a mobile telephone with a display control portion 17, reception control portion 2, a call origination control portion 3 and a speaking control portion 4. Microprocessors (such as the ARM7TDMI) were widely implemented in mobile stations at the time of the alleged invention to control functionality within the mobile station. *See, e.g., S. Segars, “The ARM9 family-high performance microprocessors for embedded applications”, Proc. ICCD, pp. 230-235, 1998-Oct.* A person of ordinary skill in the art at the time of the alleged invention would therefore understand Miyashita to necessarily disclose a “microprocessor adapted to.”

To the extent Miyashita is deemed to not expressly or inherently disclose “a microprocessor,” Miyashita renders it obvious to one of skill in the art to use “a microprocessor.” A person of ordinary skill in the art at the time of the alleged invention would understand that the functionality of display control portion 17, reception control portion 2, a call origination control portion 3 and a speaking control portion 4 could be implemented using a microprocessor such as the ARM7TDMI. *See, e.g., S. Segars, “The ARM9 family-high performance microprocessors for embedded applications”, Proc. ICCD, pp. 230-235, 1998-Oct.* Doing so would be a design choice driven by a number of different reasons, including that it would support Miyashita’s ability to conserve battery power in mobile stations, and doing so would be within the knowledge and ability of a person of ordinary skill in the art at the time of the alleged invention. The use of a microprocessor would constitute, at least, combining prior art elements according to known methods to yield predictable results, a simple substitution of one known element for another to obtain predictable results, the use of a known technique to improve similar devices in the same way, the application of a known technique to a known device ready for improvement to yield a predictable result, and obvious to try.

To the extent Miyashita is deemed to not expressly or inherently disclose “a microprocessor adapted to,” it would be obvious to combine the disclosure of Miyashita with those of Numazawa as described in the Numazawa claim chart, which is incorporated herein in its entirety by reference. Miyashita and Numazawa are both directed to conserving battery power in mobile stations generally and more particularly at conserving battery power in mobile stations by using sensors to detect when the user of the mobile station is in a call and unlikely to be looking at the display (as when, for example, the proximity sensor detects the user’s ear by the mobile station or a sensor detects that the mobile station is in a vertical orientation) and to power off the display of mobile stations at such times. Miyashita at 1:58-63 (“The present invention is directed to solving the problem set forth above. It is therefore an object of the present invention to provide a portable telephone set which can shut off the power supply for a display portion while a content of the display will not be seen during speaking, and thus can reduce power consumption.”), 2:6-11 (“In the preferred construction the detector is a gyro. The control apparatus may shut off the power supply for the display when the detector detects the main body at a substantially vertical position. On the other hand, the control may initiate power supply for the display when the detector detects the main body at a substantially horizontal position.”); Numazawa at ¶ Abstract (“To achieve reduced power consumption through stopping operation of unnecessary functions during use of a wireless terminal. A CPU 2 identifies start of a call state through a signal from a signal processing portion 3 for controlling communication with a base station, and identifies, through an output signal from detecting means 6, whether or not a user ear is in contact with a terminal. Upon identification of contact of the ear to the terminal, controlling means 8 are caused to stop the supply of electric power, from a power supply 7, to displaying means 9 for providing information to a user, and lighting means 10, such as a black light.”), ¶ 0005-0007 (“In the present invention, control is such that, upon determination that the wireless terminal is in a call, operation of functions believe be unnecessary, due to the user of the terminal being in a call, is stopped, and upon termination of the call, operation of the stopped functions is restarted. Additionally, because it is envisioned that there will also be cases where, even during a call, the face of the user may be separated from the receiver of the terminal, control is performed so as to enable restarting of the operations of the functions that had been stopped as unnecessary, through detecting whether or not the user of the terminal has the receiver in contact with an ear. The achievement of reduced power

consumption through stopping operation of functions that become unnecessary in use of the terminal, as described above, can be anticipated to have the effect of extending the life of the power supply, such as a battery.”). A person of ordinary skill in the art at the time of the alleged invention would be motivated to modify Miyashita to use “a microprocessor adapted to” as disclosed in Numazawa for a number of different reasons, including that it would support Miyashita’s ability to conserve battery power in mobile stations, and doing so would be within the knowledge and ability of a person of ordinary skill in the art at the time of the alleged invention. The combination would constitute, at least, combining prior art elements according to known methods to yield predictable results, a simple substitution of one known element for another to obtain predictable results, the use of a known technique to improve similar devices in the same way, the application of a known technique to a known device ready for improvement to yield a predictable result, and obvious to try.

To the extent Miyashita is deemed to not expressly or inherently disclose “a microprocessor adapted to” it would be obvious to combine the disclosure of Miyashita with those of Perez as described in the Perez claim chart, which is incorporated herein in its entirety by reference. Miyashita and Perez are both directed to conserving battery power in mobile stations generally and more particularly at conserving battery power in mobile stations by using sensors to detect when the user of the mobile station is in a call and unlikely to be looking at the display (as when, for example, the proximity sensor detects the user’s ear by the mobile station or a sensor detects that the mobile station is in a vertical orientation) and to power off the display of mobile stations at such times. Miyashita at 1:58-63 (“The present invention is directed to solving the problem set forth above. It is therefore an object of the present invention to provide a portable telephone set which can shut off the power supply for a display portion while a content of the display will not be seen during speaking, and thus can reduce power consumption.”), 2:6-11 (“In the preferred construction the detector is a gyro. The control apparatus may shut off the power supply for the display when the detector detects the main body at a substantially vertical position. On the other hand, the control may initiate power supply for the display when the detector detects the main body at a substantially horizontal position.”); Perez at ¶ 0013 (“Referring to FIG.

1, a portable communication product 10 such as a cellular phone includes a transceiver radio having a microphone 20, an earpiece 22, a keypad 18 and a display 12 (such as a color display) coupled to the transceiver radio. The portable communication product 10 further includes at least one sensor (24, 26, 28 or 30) and a processor 16. The sensor can be used for detecting a user condition of the portable communication device such as a talk condition when the user is assumed to be talking on the portable communication device. The processor 16 can be programmed to at least reduce power provided to the display 12 when the sensor detects the talk condition. The processor 16 can also turn off power to the display 12 during a talk condition if desired.’). A person of ordinary skill in the art at the time of the alleged invention would be motivated to modify Miyashita to use “a microprocessor adapted to” as disclosed in Perez for a number of different reasons, including that it would support Miyashita’s ability to conserve battery power in mobile stations, and doing so would be within the knowledge and ability of a person of ordinary skill in the art at the time of the alleged invention. The combination would constitute, at least, combining prior art elements according to known methods to yield predictable results, a simple substitution of one known element for another to obtain predictable results, the use of a known technique to improve similar devices in the same way, the application of a known technique to a known device ready for improvement to yield a predictable result, and obvious to try.

To the extent Miyashita is deemed to not expressly or inherently disclose “a proximity sensor adapted to generate a signal indicative of proximity of an external object,” it would be obvious to combine the disclosure of Miyashita with those of Seo as described in the Seo claim chart, which is incorporated herein in its entirety by reference. Miyashita and Seo are both directed to conserving battery power in mobile stations generally and more particularly at conserving battery power in mobile stations by using sensors to detect when the user of the mobile station is in a call and unlikely to be looking at the display (as when, for example, the proximity sensor detects the user’s ear by the mobile station or a sensor detects that the mobile station is in a vertical orientation) and to power off the display of mobile stations at such times. Miyashita at 1:58-63 (“The present invention is directed to solving the problem set forth above. It is therefore an object of the present invention to provide a portable telephone set which

	<p>can shut off the power supply for a display portion while a content of the display will not be seen during speaking, and thus can reduce power consumption.”), 2:6-11 (“In the preferred construction the detector is a gyro. The control apparatus may shut off the power supply for the display when the detector detects the main body at a substantially vertical position. On the other hand, the control may initiate power supply for the display when the detector detects the main body at a substantially horizontal position.”); Seo at 1:36-42 (“It is hence a primary object of the invention to present a novel cordless telephone capable of, by solving the above mentioned technical problems, stopping the display action by the display device while the handset is in service so as to minimize the wasteful consumption of the electric power supplied from the battery or the like.”), 3:64-4:5 (When the receiver 6 is not in contact with the user’s ear, the light emitting element 3 lights up at step n8. In this state, when the user touches the receiver 6 of the handset by the ear, it is detected by the piezoelectric element 7, and the detection signal is sent out to the control circuit 11. The control circuit 11, on the basis of this detection signal, sends out a stop signal to the driver 12. Thus, driving of the driver 12 is stopped, and the light emitting element 3 is extinguished at step n7.”). A person of ordinary skill in the art at the time of the alleged invention would be motivated to modify Miyashita to use “a microprocessor adapted to” as disclosed in Seo for a number of different reasons, including that it would support Miyashita’s ability to conserve battery power in mobile stations, and doing so would be within the knowledge and ability of a person of ordinary skill in the art at the time of the alleged invention. The combination would constitute, at least, combining prior art elements according to known methods to yield predictable results, a simple substitution of one known element for another to obtain predictable results, the use of a known technique to improve similar devices in the same way, the application of a known technique to a known device ready for improvement to yield a predictable result, and obvious to try.</p>
<p>[1d] (a) determine whether a telephone call is active;</p>	<p>Miyashita discloses the microprocessor adapted to determine whether a telephone call is active:</p> <p>For example:</p>

“For a portable telephone set having a display portion for displaying various information associated with call or origination and reception, a gyro for detecting inclination of a main body is provided.” Miyashita at Abstract.

“FIG. 1 is a block diagram showing a construction of one embodiment of the portable telephone set according to the present invention. FIG. 1, encompasses one embodiment of the portable telephone set according to the invention with substantially the same construction as FIG. 4 except for a display portion 16, a display control portion 17 and a gyro 18 as additional components.” Miyashita at 3:27-33.

FIG. 1

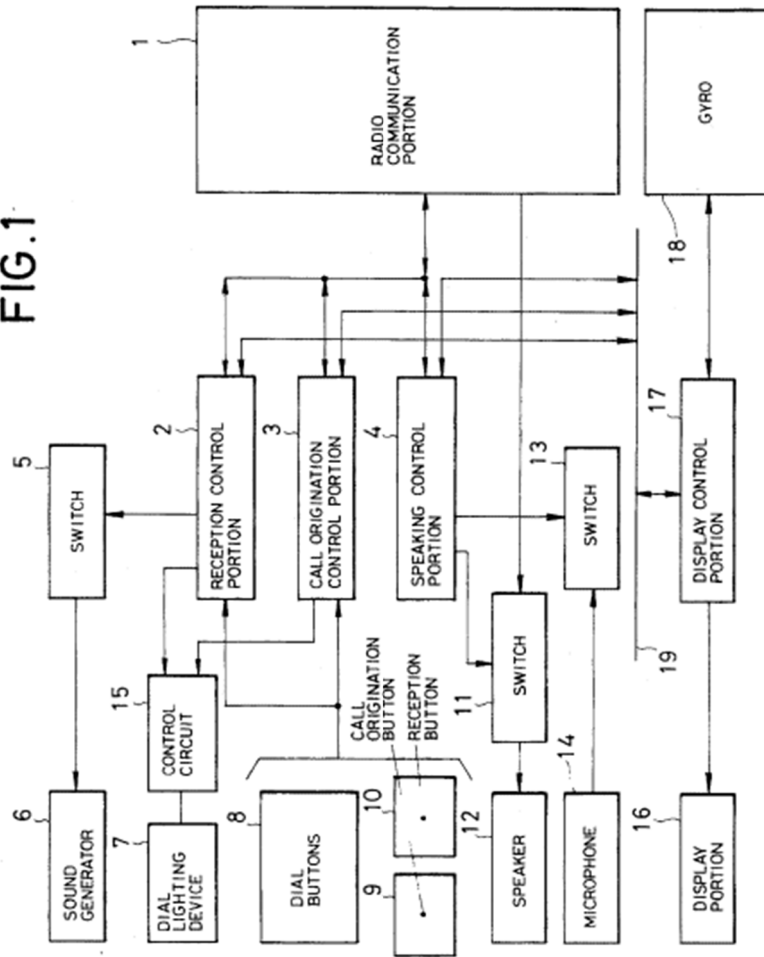

Miyashita at Fig. 1.

“The display control portion 17 is connected to a reception control portion 2, a call origination control portion 3 and a speaking control portion 4, respectively, via a common path 19. Control information associated with speaking is displayed on the display portion 16. On the other hand, the display control portion 17 also controls power supply for the display portion 16.” Miyashita at 3:39-46.

“The display control portion 17 is responsive to the inclination angle information indicative of a substantially horizontal orientation of the main body and to one of reception control command from the reception control portion 2 and a call origination control command from the call origination control portion 3, to control a power source to supply a power to the display portion 16.” Miyashita at 3:51-56.

“In FIG. 2 when the dial buttons 8 of the portable telephone set are to be operated, the main body 20 should be held in substantially horizontal orientation, directing dial buttons 8 and the display portion 16 upwardly.

At this condition, when dial buttons 8, call origination button 9 and reception button 10 are selectively depressed, connection to the remote terminal is established for enabling speaking. During speaking, the main body 20 is held in substantially vertical orientation.” Miyashita at 4:9-17.

“Thus, according to the shown embodiment, when the inclination angle information indicative that the main body is in a substantially horizontal orientation and when the reception control command from the reception control portion 2 and the call origination control command from the call origination control portion 3, the display control portion 17 starts the supply of the power. “Miyashita at 4:30-36.

To the extent Miyashita is deemed to not expressly disclose the microprocessor adapted to “determine whether a telephone call is active,” Miyashita inherently discloses this limitation. Miyashita specifies that the display control portion 17 can shut off power to the display portion 16 in response to inclination angle information from the gyro 18 that indicates a vertical orientation for the portable telephone set, only “[a]fter speaking is star[t]ed.” *See* Miyashita at 4:21-45. A person of ordinary skill in the art at the time of the alleged invention would therefore understand that, in order for the portable telephone set to determine whether “speaking is started” it must necessarily

“determine[s] whether a telephone call is active.” Further as noted above for element [1c] and incorporated by reference here, Miyashita discloses or renders obvious the use of a microprocessor. Therefore, a person of ordinary skill in the art at the time of the alleged invention would understand that necessarily the microprocessor would “determine whether a telephone call is active.”

To the extent Miyashita is deemed to not expressly disclose the microprocessor adapted to “determine whether a telephone call is active,” Miyashita renders this limitation obvious to one of ordinary skill in the art at the time of the alleged invention. Miyashita specifies that the display control portion 17 can shut off power to the display portion 16 in response to inclination angle information from the gyro 18 that indicates a vertical orientation for the portable telephone set, only “[a]fter speaking is star[t]ed.” See Miyashita at 4:21-45. Further as noted above for element [1c] and incorporated by reference here, Miyashita discloses or renders obvious the use of a microprocessor. A person of ordinary skill in the art at the time of the alleged invention would find it obvious to implement the microprocessor of Miyashita to determine whether the “speaking is started.” Doing so would be a design choice driven by a number of different reasons, including that it would support Miyashita’s ability to conserve battery power in mobile stations, and doing so would be within the knowledge and ability of a person of ordinary skill in the art at the time of the alleged invention. Doing so would also constitute, at least, combining prior art elements according to known methods to yield predictable results, a simple substitution of one known element for another to obtain predictable results, the use of a known technique to improve similar devices in the same way, the application of a known technique to a known device ready for improvement to yield a predictable result, and obvious to try.

To the extent Miyashita is deemed to not expressly or inherently disclose a microprocessor adapted to “determine whether a telephone call is active,” it would be obvious to combine the disclosure of Miyashita with those of Numazawa as described

in the Numazawa claim chart, which is incorporated herein in its entirety by reference. Miyashita and Numazawa are both directed to conserving battery power in mobile stations generally and more particularly at conserving battery power in mobile stations by using sensors to detect when the user of the mobile station is in a call and unlikely to be looking at the display (as when, for example, the proximity sensor detects the user's ear by the mobile station or a sensor detects that the mobile station is in a vertical orientation) and to power off the display of mobile stations at such times. Miyashita at 1:58-63 ("The present invention is directed to solving the problem set forth above. It is therefore an object of the present invention to provide a portable telephone set which can shut off the power supply for a display portion while a content of the display will not be seen during speaking, and thus can reduce power consumption."), 2:6-11 ("In the preferred construction the detector is a gyro. The control apparatus may shut off the power supply for the display when the detector detects the main body at a substantially vertical position. On the other hand, the control may initiate power supply for the display when the detector detects the main body at a substantially horizontal position."); Numazawa at ¶ Abstract ("To achieve reduced power consumption through stopping operation of unnecessary functions during use of a wireless terminal. A CPU 2 identifies start of a call state through a signal from a signal processing portion 3 for controlling communication with a base station, and identifies, through an output signal from detecting means 6, whether or not a user ear is in contact with a terminal. Upon identification of contact of the ear to the terminal, controlling means 8 are caused to stop the supply of electric power, from a power supply 7, to displaying means 9 for providing information to a user, and lighting means 10, such as a black light."), ¶ 0005-0007 ("In the present invention, control is such that, upon determination that the wireless terminal is in a call, operation of functions believe be unnecessary, due to the user of the terminal being in a call, is stopped, and upon termination of the call, operation of the stopped functions is restarted. Additionally, because it is envisioned that there will also be cases where, even during a call, the face of the user may be separated from the receiver of the terminal, control is performed so as to enable restarting of the operations of the functions that had been stopped as unnecessary, through detecting whether or not the user of the terminal has the receiver in contact with an ear. The achievement of reduced power consumption through stopping operation of functions that become unnecessary in use of the terminal, as described above, can be anticipated to have the effect of extending the life of the power supply,

such as a battery.”). A person of ordinary skill in the art at the time of the alleged invention would be motivated to modify Miyashita to use a microprocessor adapted to “determine whether a telephone call is active,” as disclosed in Numazawa for a number of different reasons, including that it would support Miyashita’s ability to conserve battery power in mobile stations, and doing so would be within the knowledge and ability of a person of ordinary skill in the art at the time of the alleged invention. The combination would constitute, at least, combining prior art elements according to known methods to yield predictable results, a simple substitution of one known element for another to obtain predictable results, the use of a known technique to improve similar devices in the same way, the application of a known technique to a known device ready for improvement to yield a predictable result, and obvious to try.

To the extent Miyashita is deemed to not expressly or inherently disclose a microprocessor adapted to “determine whether a telephone call is active,” it would be obvious to combine the disclosure of Miyashita with those of Perez as described in the Perez claim chart, which is incorporated herein in its entirety by reference. Miyashita and Perez are both directed to conserving battery power in mobile stations generally and more particularly at conserving battery power in mobile stations by using sensors to detect when the user of the mobile station is in a call and unlikely to be looking at the display (as when, for example, the proximity sensor detects the user’s ear by the mobile station or a sensor detects that the mobile station is in a vertical orientation) and to power off the display of mobile stations at such times. Miyashita at 1:58-63 (“The present invention is directed to solving the problem set forth above. It is therefore an object of the present invention to provide a portable telephone set which can shut off the power supply for a display portion while a content of the display will not be seen during speaking, and thus can reduce power consumption.”), 2:6-11 (“In the preferred construction the detector is a gyro. The control apparatus may shut off the power supply for the display when the detector detects the main body at a substantially vertical position. On the other hand, the control may initiate power supply for the display when the detector detects the main body at a substantially horizontal position.”); Perez at ¶ 0013 (“Referring to FIG. 1, a portable communication product 10 such as a cellular phone includes a transceiver radio having a microphone 20, an

earpiece 22, a keypad 18 and a display 12 (such as a color display) coupled to the transceiver radio. The portable communication product 10 further includes at least one sensor (24, 26, 28 or 30) and a processor 16. The sensor can be used for detecting a user condition of the portable communication device such as a talk condition when the user is assumed to be talking on the portable communication device. The processor 16 can be programmed to at least reduce power provided to the display 12 when the sensor detects the talk condition. The processor 16 can also turn off power to the display 12 during a talk condition if desired.”). A person of ordinary skill in the art at the time of the alleged invention would be motivated to modify Miyashita to use a microprocessor adapted to “determine whether a telephone call is active,” as disclosed in Perez for a number of different reasons, including that it would support Miyashita’s ability to conserve battery power in mobile stations, and doing so would be within the knowledge and ability of a person of ordinary skill in the art at the time of the alleged invention. The combination would constitute, at least, combining prior art elements according to known methods to yield predictable results, a simple substitution of one known element for another to obtain predictable results, the use of a known technique to improve similar devices in the same way, the application of a known technique to a known device ready for improvement to yield a predictable result, and obvious to try.

To the extent Miyashita is deemed to not expressly or inherently disclose a microprocessor adapted to “determine whether a telephone call is active,” it would be obvious to combine the disclosure of Miyashita with those of Seo as described in the Seo claim chart, which is incorporated herein in its entirety by reference. Miyashita and Seo are both directed to conserving battery power in mobile stations generally and more particularly at conserving battery power in mobile stations by using sensors to detect when the user of the mobile station is in a call and unlikely to be looking at the display (as when, for example, the proximity sensor detects the user’s ear by the mobile station or a sensor detects that the mobile station is in a vertical orientation) and to power off the display of mobile stations at such times. Miyashita at 1:58-63 (“The present invention is directed to solving the problem set forth above. It is therefore an object of the present invention to provide a portable telephone set which can shut off the power supply for a display portion while a content of the display will not be seen

	<p>during speaking, and thus can reduce power consumption.”), 2:6-11 (“In the preferred construction the detector is a gyro. The control apparatus may shut off the power supply for the display when the detector detects the main body at a substantially vertical position. On the other hand, the control may initiate power supply for the display when the detector detects the main body at a substantially horizontal position.”); Seo at 1:36-42 (“It is hence a primary object of the invention to present a novel cordless telephone capable of, by solving the above mentioned technical problems, stopping the display action by the display device while the handset is in service so as to minimize the wasteful consumption of the electric power supplied from the battery or the like.”), 3:64-4:5 (When the receiver 6 is not in contact with the user’s ear, the light emitting element 3 lights up at step n8. In this state, when the user touches the receiver 6 of the handset by the ear, it is detected by the piezoelectric element 7, and the detection signal is sent out to the control circuit 11. The control circuit 11, on the basis of this detection signal, sends out a stop signal to the driver 12. Thus, driving of the driver 12 is stopped, and the light emitting element 3 is extinguished at step n7.”). A person of ordinary skill in the art at the time of the alleged invention would be motivated to modify Miyashita to use a microprocessor adapted to “determine whether a telephone call is active,” as disclosed in Seo for a number of different reasons, including that it would support Miyashita’s ability to conserve battery power in mobile stations, and doing so would be within the knowledge and ability of a person of ordinary skill in the art at the time of the alleged invention. The combination would constitute, at least, combining prior art elements according to known methods to yield predictable results, a simple substitution of one known element for another to obtain predictable results, the use of a known technique to improve similar devices in the same way, the application of a known technique to a known device ready for improvement to yield a predictable result, and obvious to try.</p>
<p>[1e] (b) receive the signal from the proximity sensor; and</p>	<p>Miyashita discloses the microprocessor adapted to receive the signal from the proximity sensor:</p> <p>For example:</p>

	<p>Miyashita at Fig. 1.</p> <p>“The gyro 18 detects an inclination of a main body the portable telephone set to provide information concerning an inclination angle to the display control portion 17. The display control portion 17 receives the inclination angle information from the gyro 18.” Miyashita at 3:46-64.</p> <p>“The orientations of the main body 20 as illustrated in FIGS. 2 and 3, are detected by the gyro 18 and the inclination angle information is input to the display control portion 17, as set forth above.”</p> <p>To the extent Miyashita is deemed to not expressly disclose a microprocessor adapted to “receive the signal from the proximity sensor,” Miyashita inherently discloses this limitation and/or renders obvious this limitation to one of ordinary skill in the art at the time of the alleged invention for the reasons discussed in claim elements [1b] and [1c], <i>supra</i>, which are incorporated herein by reference.</p>
<p>[1f] (c) reduce power to the display if (i) the microprocessor determines that a telephone call is active and (ii) the signal indicates the proximity of the external object; wherein:</p>	<p>Miyashita discloses the microprocessor adapted to reduce power to the display if (i) the microprocessor determines that a telephone call is active and (ii) the signal indicates the proximity of the external object:</p> <p>For example:</p> <p><i>See</i> discussions of claim elements [1b], [1d], [1e], <i>supra</i>, which are incorporated herein by reference.</p>

“According to another aspect of the invention, a portable telephone set comprises:
call origination control device responsive to a dialing operation for controlling call origination;

reception control apparatus responsive to reception of call for controlling reception;

display device for displaying information associated with call origination and reception;

a main body housing the call origination control, the reception control and the display;

detector apparatus for detecting inclination of the main body; and

control for controlling the power supply for the display, the control being responsive to the detector detecting a, substantially horizontal position of the main body for initiating power supply for the display.

The control may be responsive to the detector detecting a substantially vertical position for speaking after dialing operation, for shutting off the power supply for the display.”
Miyashita at 2:12-32.

“The display control portion 17 is connected to a reception control portion 2, a call origination control portion 3 and a speaking control portion 4, respectively, via a common path 19. Control information associated with speaking is displayed on the display portion 16. On the other hand, the display control portion 17 also controls power supply for the display portion 16.

The gyro 18 detects an inclination of a main body the portable telephone set to provide information concerning an inclination angle to the display control portion 17. The display control portion 17 receives the inclination angle information from the gyro 18. The display control portion 17 is responsive to the inclination angle information

indicative of a substantially horizontal orientation of the main body and to one of reception control command from the reception control portion 2 and a call origination control command from the call origination control portion 3, to control a power source to supply a power to the display portion 16.

In contrast, the display control portion 17 is responsive to the inclination angle information indicative of variation of the inclination angle from the substantially horizontal orientation to the substantially vertical orientation while it performs display control for the display portion 16 to display the control information, to terminate the power supply for the display portion 16.

When speaking is performed with the destination person via the speaker 12 and the microphone 14, it is rare to require seeing the display content on the display portion 16. Therefore, the power supply for the display portion 16 is shut down. Thus, exhausting of a battery can be reduced.” Miyashita at 3:39-4:2.

“Thus, according to the shown embodiment, when the inclination angle information indicative that the main body is in a substantially horizontal orientation and when the reception control command from the reception control portion 2 and the call origination control command from the call origination control portion 3, the display control portion 17 starts the supply of the power. After speaking is started, when the inclination angle information indicative of a variation of orientation of the main body from the horizontal position to the vertical position, the display control portion shuts off power supply for the display portion 16. Therefore, in the state of the portable telephone set in which the display portion 16 will not be seen, no power will be supplied to the display portion 16. Therefore, power consumption can be reduced. As well, it should serve for reducing the depletion of the battery.” Miyashita at 4:30-45.

To the extent Miyashita is deemed to not expressly or inherently disclose a microprocessor adapted to “reduce power to the display if (i) the microprocessor determines that a telephone call is active and (ii) the signal indicates the proximity of

the external object,” Miyashita renders it obvious to one of ordinary skill in the art at the time of the alleged invention. Miyashita discloses a gyro that indicates the inclination angle (vertical vs. horizontal) of the mobile station for the purpose of indicating whether a user is likely looking or not looking at the display of the mobile station and/or talking on the mobile station. *See* Miyashita at 3:46-4:2 (“The gyro 18 detects an inclination of a main body the portable telephone set to provide information concerning an inclination angle to the display control portion 17. The display control portion 17 receives the inclination angle information from the gyro 18. The display control portion 17 is responsive to the inclination angle information indicative of a substantially horizontal orientation of the main body and to one of reception control command from the reception control portion 2 and a call origination control command from the call origination control portion 3, to control a power source to supply a power to the display portion 16. In contrast, the display control portion 17 is responsive to the inclination angle information indicative of variation of the inclination angle from the substantially horizontal orientation to the substantially vertical orientation while it performs display control for the display portion 16 to display the control information, to terminate the power supply for the display portion 16. When speaking is performed with the destination person via the speaker 12 and the microphone 14, it is rare to require seeing the display content on the display portion 16. Therefore, the power supply for the display portion 16 is shut down. Thus, exhausting of a battery can be reduced.”). A person of ordinary skill in the art at the time of the alleged invention would have understood that various sensors can be used in a mobile station for the purpose of indicating whether a user is likely looking or not looking at the display of the mobile station and/or talking on the mobile station. *See, e.g.,* Perez at ¶ 0022 (“[T]he step of detecting a talk condition can be achieved by monitoring or detecting at least one among the conditions of a) detecting if a predetermined volume of acoustic sound is being received at a microphone indicative of a user talking on the portable communication device; b) measuring at least one among a spectrum density and a spectrum energy of a bounced signal to determine the proximity of a user’s head to an earpiece of the portable communication device; c) measuring a predetermined period after a phone call starts; d) detecting an angle at which the portable communication device is positioned; e) detecting a vibration of the portable communication device; or f) detecting if the portable communication device is in a user’s hand. How the method 50 can detect the conditions described above can be embodied in many different forms

using individually or in combination sensors and timers and other devices”). A person of ordinary skill in the art at the time of the alleged invention would therefore have understood that the invention of Miyashita could be performed using a proximity sensor instead of or in addition to a gyro for the purpose of indicating whether a user is likely looking or not looking at the display of the mobile station and/or talking on the mobile station. As described above, and in elements [1b]-[1e], which are which are incorporated herein by reference, Miyashita already teaches at least a microprocessor adapted to (c) reduce power to the display if (i) the microprocessor determines that a telephone call is active and (ii) the gyro indicates the mobile station is in a vertical orientation. It would therefore be obvious and a person of ordinary skill in the art at the time of the invention would be motivated to use a microprocessor adapted to (c) reduce power to the display if (i) the microprocessor determines that a telephone call is active and (ii) the signal indicates the proximity of the external object (instead of or in addition to the gyro indicates the mobile station is in a vertical orientation). Doing so would be a design choice driven by a number of different reasons, including that it would support Miyashita’s ability to conserve battery power in mobile stations, and would be within the knowledge and ability of a person of ordinary skill in the art at the time of the alleged invention. Doing so would constitute, at least, combining prior art elements according to known methods to yield predictable results, a simple substitution of one known element for another to obtain predictable results, the use of a known technique to improve similar devices in the same way, the application of a known technique to a known device ready for improvement to yield a predictable result, and obvious to try.

To the extent Miyashita is deemed to not expressly or inherently disclose a microprocessor adapted to “reduce power to the display if (i) the microprocessor determines that a telephone call is active and (ii) the signal indicates the proximity of the external object,” it would be obvious to combine the disclosure of Miyashita with those of Numazawa as described in the Numazawa claim chart, which is incorporated herein in its entirety by reference. Miyashita and Numazawa are both directed to conserving battery power in mobile stations generally and more particularly at conserving battery power in mobile stations by using sensors to detect when the user of

the mobile station is in a call and unlikely to be looking at the display (as when, for example, the proximity sensor detects the user's ear by the mobile station or a sensor detects that the mobile station is in a vertical orientation) and to power off the display of mobile stations at such times. Miyashita at 1:58-63 (“The present invention is directed to solving the problem set forth above. It is therefore an object of the present invention to provide a portable telephone set which can shut off the power supply for a display portion while a content of the display will not be seen during speaking, and thus can reduce power consumption.”), 2:6-11 (“In the preferred construction the detector is a gyro. The control apparatus may shut off the power supply for the display when the detector detects the main body at a substantially vertical position. On the other hand, the control may initiate power supply for the display when the detector detects the main body at a substantially horizontal position.”); Numazawa at ¶ Abstract (“To achieve reduced power consumption through stopping operation of unnecessary functions during use of a wireless terminal. A CPU 2 identifies start of a call state through a signal from a signal processing portion 3 for controlling communication with a base station, and identifies, through an output signal from detecting means 6, whether or not a user ear is in contact with a terminal. Upon identification of contact of the ear to the terminal, controlling means 8 are caused to stop the supply of electric power, from a power supply 7, to displaying means 9 for providing information to a user, and lighting means 10, such as a black light.”), ¶ 0005-0007 (“In the present invention, control is such that, upon determination that the wireless terminal is in a call, operation of functions believe be unnecessary, due to the user of the terminal being in a call, is stopped, and upon termination of the call, operation of the stopped functions is restarted. Additionally, because it is envisioned that there will also be cases where, even during a call, the face of the user may be separated from the receiver of the terminal, control is performed so as to enable restarting of the operations of the functions that had been stopped as unnecessary, through detecting whether or not the user of the terminal has the receiver in contact with an ear. The achievement of reduced power consumption through stopping operation of functions that become unnecessary in use of the terminal, as described above, can be anticipated to have the effect of extending the life of the power supply, such as a battery.”). A person of ordinary skill in the art at the time of the alleged invention would be motivated to modify Miyashita to use a microprocessor adapted to “reduce power to the display if (i) the microprocessor determines that a telephone call is active and (ii) the signal indicates the proximity of

the external object,” as disclosed in Numazawa for a number of different reasons, including that it would support Miyashita’s ability to conserve battery power in mobile stations, and doing so would be within the knowledge and ability of a person of ordinary skill in the art at the time of the alleged invention. The combination would constitute, at least, combining prior art elements according to known methods to yield predictable results, a simple substitution of one known element for another to obtain predictable results, the use of a known technique to improve similar devices in the same way, the application of a known technique to a known device ready for improvement to yield a predictable result, and obvious to try.

To the extent Miyashita is deemed to not expressly or inherently disclose a microprocessor adapted to “reduce power to the display if (i) the microprocessor determines that a telephone call is active and (ii) the signal indicates the proximity of the external object,” it would be obvious to combine the disclosure of Miyashita with those of Perez as described in the Perez claim chart, which is incorporated herein in its entirety by reference. Miyashita and Perez are both directed to conserving battery power in mobile stations generally and more particularly at conserving battery power in mobile stations by using sensors to detect when the user of the mobile station is in a call and unlikely to be looking at the display (as when, for example, the proximity sensor detects the user’s ear by the mobile station or a sensor detects that the mobile station is in a vertical orientation) and to power off the display of mobile stations at such times. Miyashita at 1:58-63 (“The present invention is directed to solving the problem set forth above. It is therefore an object of the present invention to provide a portable telephone set which can shut off the power supply for a display portion while a content of the display will not be seen during speaking, and thus can reduce power consumption.”), 2:6-11 (“In the preferred construction the detector is a gyro. The control apparatus may shut off the power supply for the display when the detector detects the main body at a substantially vertical position. On the other hand, the control may initiate power supply for the display when the detector detects the main body at a substantially horizontal position.”); Perez at ¶ 0013 (“Referring to FIG. 1, a portable communication product 10 such as a cellular phone includes a transceiver radio having a microphone 20, an earpiece 22, a keypad 18 and a display 12 (such as a

color display) coupled to the transceiver radio. The portable communication product 10 further includes at least one sensor (24, 26, 28 or 30) and a processor 16. The sensor can be used for detecting a user condition of the portable communication device such as a talk condition when the user is assumed to be talking on the portable communication device. The processor 16 can be programmed to at least reduce power provided to the display 12 when the sensor detects the talk condition. The processor 16 can also turn off power to the display 12 during a talk condition if desired.”). A person of ordinary skill in the art at the time of the alleged invention would be motivated to modify Miyashita to use a microprocessor adapted to “reduce power to the display if (i) the microprocessor determines that a telephone call is active and (ii) the signal indicates the proximity of the external object,” as disclosed in Perez for a number of different reasons, including that it would support Miyashita’s ability to conserve battery power in mobile stations, and doing so would be within the knowledge and ability of a person of ordinary skill in the art at the time of the alleged invention. The combination would constitute, at least, combining prior art elements according to known methods to yield predictable results, a simple substitution of one known element for another to obtain predictable results, the use of a known technique to improve similar devices in the same way, the application of a known technique to a known device ready for improvement to yield a predictable result, and obvious to try.

To the extent Miyashita is deemed to not expressly or inherently disclose a microprocessor adapted to “reduce power to the display if (i) the microprocessor determines that a telephone call is active and (ii) the signal indicates the proximity of the external object,” it would be obvious to combine the disclosure of Miyashita with those of Seo as described in the Seo claim chart, which is incorporated herein in its entirety by reference. Miyashita and Seo are both directed to conserving battery power in mobile stations generally and more particularly at conserving battery power in mobile stations by using sensors to detect when the user of the mobile station is in a call and unlikely to be looking at the display (as when, for example, the proximity sensor detects the user’s ear by the mobile station or a sensor detects that the mobile station is in a vertical orientation) and to power off the display of mobile stations at such times. Miyashita at 1:58-63 (“The present invention is directed to solving the problem set

forth above. It is therefore an object of the present invention to provide a portable telephone set which can shut off the power supply for a display portion while a content of the display will not be seen during speaking, and thus can reduce power consumption.”), 2:6-11 (“In the preferred construction the detector is a gyro. The control apparatus may shut off the power supply for the display when the detector detects the main body at a substantially vertical position. On the other hand, the control may initiate power supply for the display when the detector detects the main body at a substantially horizontal position.”); Seo at 1:36-42 (“It is hence a primary object of the invention to present a novel cordless telephone capable of, by solving the above mentioned technical problems, stopping the display action by the display device while the handset is in service so as to minimize the wasteful consumption of the electric power supplied from the battery or the like.”), 3:64-4:5 (When the receiver 6 is not in contact with the user’s ear, the light emitting element 3 lights up at step n8. In this state, when the user touches the receiver 6 of the handset by the ear, it is detected by the piezoelectric element 7, and the detection signal is sent out to the control circuit 11. The control circuit 11, on the basis of this detection signal, sends out a stop signal to the driver 12. Thus, driving of the driver 12 is stopped, and the light emitting element 3 is extinguished at step n7.”). A person of ordinary skill in the art at the time of the alleged invention would be motivated to modify Miyashita to use a microprocessor adapted to “reduce power to the display if (i) the microprocessor determines that a telephone call is active and (ii) the signal indicates the proximity of the external object,” as disclosed in Seo for a number of different reasons, including that it would support Miyashita’s ability to conserve battery power in mobile stations, and doing so would be within the knowledge and ability of a person of ordinary skill in the art at the time of the alleged invention. The combination would constitute, at least, combining prior art elements according to known methods to yield predictable results, a simple substitution of one known element for another to obtain predictable results, the use of a known technique to improve similar devices in the same way, the application of a known technique to a known device ready for improvement to yield a predictable result, and obvious to try.

[1g] the telephone call is a wireless telephone call;

Miyashita discloses the telephone call as a wireless telephone call:

For example:

See discussion of claim element 1[d], *supra*, which is incorporated herein by reference.

“For a portable telephone set having a display portion for displaying various information associated with call or origination and reception, a gyro for detecting inclination of a main body is provided.” Miyashita at Abstract.

“The present invention relates to a pocket telephone or portable telephone set. More specifically, the invention relates to a portable telephone set which has a display for displaying various information associated with call origination and reception.” Miyashita at 1:6-10.

“The conventional portable telephone set has been designed to display a number as component of dialing operation on a display upon call origination. An example of such portable telephone set with a display function is illustrated in FIG. 4.

In such portable telephone, the number is input by operating dial buttons 8, and then a call origination button 9 is depressed. By these operations, a call is performed by a call control portion 3 and a radio communication portion 1. At this time, when a remote terminal answers, a speaking control portion 4 turns switches 11 and 13 to enable conversation with a destination via person a speaker 12 and a microphone 14.

On the other hand, when a call is received from the remote terminal, a reception control portion turns a switch 5. Then, a sound generator 6 becomes active to generate a ring sound. When a reception button 10 is depressed after the ring sound is

generated, the speaking control portion 4 turns switches 11 and 13 so as to enable speaking with the caller.” Miyashita at 1:12-31.

FIG. 2

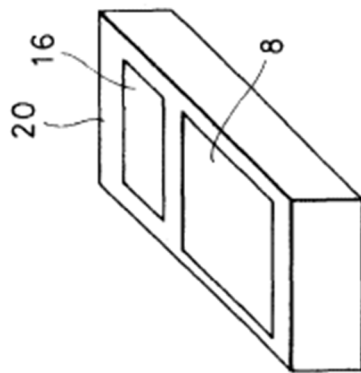
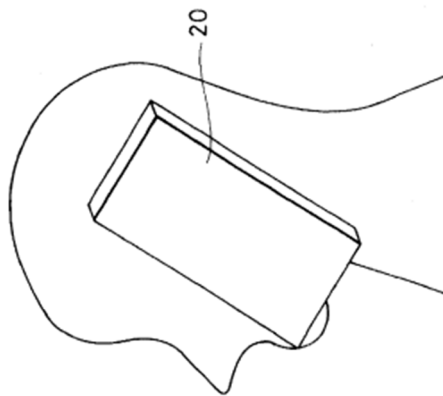

FIG. 3



Miyashita at Figs. 2, 3.

“FIG. 2 is an illustration showing inclination of the main body a during a dialing operation for the one embodiment of a portable telephone set according to the invention, and FIG. 3 is an illustration showing inclination of the main body during speaking and not out-dialing for the one embodiment of portable set according to the invention.” Miyashita at 4:3-8.

[1h] the microprocessor reduces power to the display while the signal indicates the proximity of the external object only if the microprocessor determines that the wireless telephone call is active; and

Miyashita discloses that the microprocessor reduces power to the display while the signal indicates the proximity of the external object only if the microprocessor determines that the wireless telephone call is active:

For example:

See discussion of claim element 1(f), *supra*, which is incorporated herein by reference.

“According to another aspect of the invention, a portable telephone set comprises:

call origination control device responsive to a dialing operation for controlling call origination;

reception control apparatus responsive to reception of call for controlling reception;

display device for displaying information associated with call origination and reception;

a main body housing the call origination control, the reception control and the display;

detector apparatus for detecting inclination of the main body; and

control for controlling the power supply for the display, the control being responsive to the detector detecting a, substantially horizontal position of the main body for initiating power supply for the display.

The control may be responsive to the detector detecting a substantially vertical position for speaking after dialing operation, for shutting off the power supply for the display.”
Miyashita at 2:12-32.

“The display control portion 17 is connected to a reception control portion 2, a call origination control portion 3 and a speaking control portion 4, respectively, via a

common path 19. Control information associated with speaking is displayed on the display portion 16. On the other hand, the display control portion 17 also controls power supply for the display portion 16.

The gyro 18 detects an inclination of a main body the portable telephone set to provide information concerning an inclination angle to the display control portion 17. The display control portion 17 receives the inclination angle information from the gyro 18. The display control portion 17 is responsive to the inclination angle information indicative of a substantially horizontal orientation of the main body and to one of reception control command from the reception control portion 2 and a call origination control command from the call origination control portion 3, to control a power source to supply a power to the display portion 16.

In contrast, the display control portion 17 is responsive to the inclination angle information indicative of variation of the inclination angle from the substantially horizontal orientation to the substantially vertical orientation while it performs display control for the display portion 16 to display the control information, to terminate the power supply for the display portion 16.

When speaking is performed with the destination person via the speaker 12 and the microphone 14, it is rare to require seeing the display content on the display portion 16. Therefore, the power supply for the display portion 16 is shut down. Thus, exhausting of a battery can be reduced.” Miyashita at 3:39-4:2.

“Thus, according to the shown embodiment, when the inclination angle information indicative that the main body is in a substantially horizontal orientation and when the reception control command from the reception control portion 2 and the call origination control command from the call origination control portion 3, the display control portion 17 starts the supply of the power. After speaking is started, when the inclination angle information indicative of a variation of orientation of the main body from the horizontal position to the vertical position, the display control portion shuts off power supply for the display portion 16. Therefore, in the state of the portable telephone set in which the display portion 16 will not be seen, no power will be

supplied to the display portion 16. Therefore, power consumption can be reduced. As well, it should serve for reducing the depletion of the battery.” Miyashita at 4:30-45.

To the extent Miyashita is deemed to not expressly disclose that “the microprocessor reduces power to the display while the signal indicates the proximity of the external object only if the microprocessor determines that the wireless telephone call is active,” Miyashita inherently discloses this limitation. As noted above for element [1f] and incorporated herein by reference, Miyashita discloses or renders obvious “a microprocessor adapted to reduce power to the display if (i) the microprocessor determines that a telephone call is active and (ii) the signal indicates the proximity of the external object.” Also as noted above for element [1d] and incorporated herein by reference, Miyashita discloses that detection by a sensor (such as a gyro or proximity sensor) occurs only “after talking is star[t]ed.” Therefore a person of ordinary skill in the art at the time of the alleged invention would understand that Miyashita necessarily discloses that “the microprocessor reduces power to the display while the signal indicates the proximity of the external object only if the microprocessor determines that the wireless telephone call is active.”

To the extent Miyashita is deemed to not expressly or inherently disclose that “the microprocessor reduces power to the display while the signal indicates the proximity of the external object only if the microprocessor determines that the wireless telephone call is active,” Miyashita renders it obvious to one of ordinary skill in the art at the time of the alleged invention. As noted above for element [1f] and incorporated herein by reference, Miyashita discloses or renders obvious “a microprocessor adapted to reduce power to the display if (i) the microprocessor determines that a telephone call is active and (ii) the signal indicates the proximity of the external object.” Also as noted above for element [1d] and incorporated herein by reference, Miyashita discloses that detection by a sensor (such as a gyro or proximity sensor) occurs only “after talking is started.” Therefore it would be obvious to one of ordinary skill in the art at the time of the alleged invention that “the microprocessor reduces power to the display while the

signal indicates the proximity of the external object only if the microprocessor determines that the wireless telephone call is active,” in Miyashita.

To the extent Miyashita is deemed to not expressly or inherently disclose a microprocessor adapted to “the microprocessor reduces power to the display while the signal indicates the proximity of the external object only if the microprocessor determines that the wireless telephone call is active” it would be obvious to combine the disclosure of Miyashita with those of Numazawa as described in the Numazawa claim chart, which is incorporated herein in its entirety by reference. Miyashita and Numazawa are both directed to conserving battery power in mobile stations generally and more particularly at conserving battery power in mobile stations by using sensors to detect when the user of the mobile station is in a call and unlikely to be looking at the display (as when, for example, the proximity sensor detects the user’s ear by the mobile station or a sensor detects that the mobile station is in a vertical orientation) and to power off the display of mobile stations at such times. Miyashita at 1:58-63 (“The present invention is directed to solving the problem set forth above. It is therefore an object of the present invention to provide a portable telephone set which can shut off the power supply for a display portion while a content of the display will not be seen during speaking, and thus can reduce power consumption.”), 2:6-11 (“In the preferred construction the detector is a gyro. The control apparatus may shut off the power supply for the display when the detector detects the main body at a substantially vertical position. On the other hand, the control may initiate power supply for the display when the detector detects the main body at a substantially horizontal position.”); Numazawa at ¶ Abstract (“To achieve reduced power consumption through stopping operation of unnecessary functions during use of a wireless terminal. A CPU 2 identifies start of a call state through a signal from a signal processing portion 3 for controlling communication with a base station, and identifies, through an output signal from detecting means 6, whether or not a user ear is in contact with a terminal. Upon identification of contact of the ear to the terminal, controlling means 8 are caused to stop the supply of electric power, from a power supply 7, to displaying means 9 for providing information to a user, and lighting means 10, such as a black light.”), ¶ 0005-0007 (“In the present invention, control is such that, upon determination that the

wireless terminal is in a call, operation of functions believe be unnecessary, due to the user of the terminal being in a call, is stopped, and upon termination of the call, operation of the stopped functions is restarted. Additionally, because it is envisioned that there will also be cases where, even during a call, the face of the user may be separated from the receiver of the terminal, control is performed so as to enable restarting of the operations of the functions that had been stopped as unnecessary, through detecting whether or not the user of the terminal has the receiver in contact with an ear. The achievement of reduced power consumption through stopping operation of functions that become unnecessary in use of the terminal, as described above, can be anticipated to have the effect of extending the life of the power supply, such as a battery.”). A person of ordinary skill in the art at the time of the alleged invention would be motivated to modify Miyashita to use a microprocessor adapted to “the microprocessor reduces power to the display while the signal indicates the proximity of the external object only if the microprocessor determines that the wireless telephone call is active” as disclosed in Numazawa for a number of different reasons, including that it would support Miyashita’s ability to conserve battery power in mobile stations, and doing so would be within the knowledge and ability of a person of ordinary skill in the art at the time of the alleged invention. The combination would constitute, at least, combining prior art elements according to known methods to yield predictable results, a simple substitution of one known element for another to obtain predictable results, the use of a known technique to improve similar devices in the same way, the application of a known technique to a known device ready for improvement to yield a predictable result, and obvious to try.

To the extent Miyashita is deemed to not expressly or inherently disclose a microprocessor adapted to “the microprocessor reduces power to the display while the signal indicates the proximity of the external object only if the microprocessor determines that the wireless telephone call is active” it would be obvious to combine the disclosure of Miyashita with those of Perez as described in the Perez claim chart, which is incorporated herein in its entirety by reference. Miyashita and Perez are both directed to conserving battery power in mobile stations generally and more particularly at conserving battery power in mobile stations by using sensors to detect when the user

of the mobile station is in a call and unlikely to be looking at the display (as when, for example, the proximity sensor detects the user's ear by the mobile station or a sensor detects that the mobile station is in a vertical orientation) and to power off the display of mobile stations at such times. Miyashita at 1:58-63 (“The present invention is directed to solving the problem set forth above. It is therefore an object of the present invention to provide a portable telephone set which can shut off the power supply for a display portion while a content of the display will not be seen during speaking, and thus can reduce power consumption.”), 2:6-11 (“In the preferred construction the detector is a gyro. The control apparatus may shut off the power supply for the display when the detector detects the main body at a substantially vertical position. On the other hand, the control may initiate power supply for the display when the detector detects the main body at a substantially horizontal position.”); Perez at ¶ 0013 (“Referring to FIG. 1, a portable communication product 10 such as a cellular phone includes a transceiver radio having a microphone 20, an earpiece 22, a keypad 18 and a display 12 (such as a color display) coupled to the transceiver radio. The portable communication product 10 further includes at least one sensor (24, 26, 28 or 30) and a processor 16. The sensor can be used for detecting a user condition of the portable communication device such as a talk condition when the user is assumed to be talking on the portable communication device. The processor 16 can be programmed to at least reduce power provided to the display 12 when the sensor detects the talk condition. The processor 16 can also turn off power to the display 12 during a talk condition if desired.”). A person of ordinary skill in the art at the time of the alleged invention would be motivated to modify Miyashita to use a microprocessor adapted to “the microprocessor reduces power to the display while the signal indicates the proximity of the external object only if the microprocessor determines that the wireless telephone call is active” as disclosed in Perez for a number of different reasons, including that it would support Miyashita’s ability to conserve battery power in mobile stations, and doing so would be within the knowledge and ability of a person of ordinary skill in the art at the time of the alleged invention. The combination would constitute, at least, combining prior art elements according to known methods to yield predictable results, a simple substitution of one known element for another to obtain predictable results, the use of a known technique to improve similar devices in the same way, the application of a known technique to a known device ready for improvement to yield a predictable result, and obvious to try.

To the extent Miyashita is deemed to not expressly or inherently disclose a microprocessor adapted to “reduce power to the display if (i) the microprocessor determines that a telephone call is active and (ii) the signal indicates the proximity of the external object;” it would be obvious to combine the disclosure of Miyashita with those of Seo as described in the Seo claim chart, which is incorporated herein in its entirety by reference. Miyashita and Seo are both directed to conserving battery power in mobile stations generally and more particularly at conserving battery power in mobile stations by using sensors to detect when the user of the mobile station is in a call and unlikely to be looking at the display (as when, for example, the proximity sensor detects the user’s ear by the mobile station or a sensor detects that the mobile station is in a vertical orientation) and to power off the display of mobile stations at such times. Miyashita at 1:58-63 (“The present invention is directed to solving the problem set forth above. It is therefore an object of the present invention to provide a portable telephone set which can shut off the power supply for a display portion while a content of the display will not be seen during speaking, and thus can reduce power consumption.”), 2:6-11 (“In the preferred construction the detector is a gyro. The control apparatus may shut off the power supply for the display when the detector detects the main body at a substantially vertical position. On the other hand, the control may initiate power supply for the display when the detector detects the main body at a substantially horizontal position.”); Seo at 1:36-42 (“It is hence a primary object of the invention to present a novel cordless telephone capable of, by solving the above mentioned technical problems, stopping the display action by the display device while the handset is in service so as to minimize the wasteful consumption of the electric power supplied from the battery or the like.”), 3:64-4:5 (When the receiver 6 is not in contact with the user’s ear, the light emitting element 3 lights up at step n8. In this state, when the user touches the receiver 6 of the handset by the ear, it is detected by the piezoelectric element 7, and the detection signal is sent out to the control circuit 11. The control circuit 11, on the basis of this detection signal, sends out a stop signal to the driver 12. Thus, driving of the driver 12 is stopped, and the light emitting element 3 is extinguished at step n7.”). A person of ordinary skill in the art at the time of the alleged invention would be motivated to modify Miyashita to use a microprocessor adapted to “the microprocessor reduces power to the display while the

<p>[11] the proximity sensor begins detecting whether an external object is proximate substantially concurrently with the mobile station initiating an outgoing wireless telephone call or receiving an incoming wireless telephone call.</p>	<p>signal indicates the proximity of the external object only if the microprocessor determines that the wireless telephone call is active” as disclosed in Seo for a number of different reasons, including that it would support Miyashita’s ability to conserve battery power in mobile stations, and doing so would be within the knowledge and ability of a person of ordinary skill in the art at the time of the alleged invention. The combination would constitute, at least, combining prior art elements according to known methods to yield predictable results, a simple substitution of one known element for another to obtain predictable results, the use of a known technique to improve similar devices in the same way, the application of a known technique to a known device ready for improvement to yield a predictable result, and obvious to try.</p>
<p>Miyashita discloses that the proximity sensor begins to detect whether an external object is proximate substantially concurrently with the mobile station initiating an outgoing wireless telephone call or receiving an incoming wireless telephone call:</p> <p>For example:</p> <p><i>See</i> discussion of claim element 1(f), <i>supra</i>, which is incorporated herein by reference.</p> <p>“According to another aspect of the invention, a portable telephone set comprises:</p> <p>call origination control device responsive to a dialing operation for controlling call origination;</p> <p>reception control apparatus responsive to reception of call for controlling reception;</p> <p>display device for displaying information associated with call origination and reception;</p>	<p>Miyashita discloses that the proximity sensor begins to detect whether an external object is proximate substantially concurrently with the mobile station initiating an outgoing wireless telephone call or receiving an incoming wireless telephone call:</p> <p>For example:</p> <p><i>See</i> discussion of claim element 1(f), <i>supra</i>, which is incorporated herein by reference.</p> <p>“According to another aspect of the invention, a portable telephone set comprises:</p> <p>call origination control device responsive to a dialing operation for controlling call origination;</p> <p>reception control apparatus responsive to reception of call for controlling reception;</p> <p>display device for displaying information associated with call origination and reception;</p>

a main body housing the call origination control, the reception control and the display; detector apparatus for detecting inclination of the main body; and control for controlling the power supply for the display, the control being responsive to the detector detecting a, substantially horizontal position of the main body for initiating power supply for the display.

The control may be responsive to the detector detecting a substantially vertical position for speaking after dialing operation, for shutting off the power supply for the display.” Miyashita at 2:12-32.

“The display control portion 17 is connected to a reception control portion 2, a call origination control portion 3 and a speaking control portion 4, respectively, via a common path 19. Control information associated with speaking is displayed on the display portion 16. On the other hand, the display control portion 17 also controls power supply for the display portion 16.

The gyro 18 detects an inclination of a main body the portable telephone set to provide information concerning an inclination angle to the display control portion 17. The display control portion 17 receives the inclination angle information from the gyro 18. The display control portion 17 is responsive to the inclination angle information indicative of a substantially horizontal orientation of the main body and to one of reception control command from the reception control portion 2 and a call origination control command from the call origination control portion 3, to control a power source to supply a power to the display portion 16.

In contrast, the display control portion 17 is responsive to the inclination angle information indicative of variation of the inclination angle from the substantially horizontal orientation to the substantially vertical orientation while it performs display control for the display portion 16 to display the control information, to terminate the power supply for the display portion 16.

When speaking is performed with the destination person via the speaker 12 and the microphone 14, it is rare to require seeing the display content on the display portion 16. Therefore, the power supply for the display portion 16 is shut down. Thus, exhausting of a battery can be reduced.” Miyashita at 3:39-4:2.

“Thus, according to the shown embodiment, when the inclination angle information indicative that the main body is in a substantially horizontal orientation and when the reception control command from the reception control portion 2 and the call origination control command from the call origination control portion 3, the display control portion 17 starts the supply of the power. After speaking is started, when the inclination angle information indicative of a variation of orientation of the main body from the horizontal position to the vertical position, the display control portion shuts off power supply for the display portion 16. Therefore, in the state of the portable telephone set in which the display portion 16 will not be seen, no power will be supplied to the display portion 16. Therefore, power consumption can be reduced. As well, it should serve for reducing the depletion of the battery.” Miyashita at 4:30-45.

To the extent Miyashita is deemed to not expressly disclose “the proximity sensor begins detecting whether an external object is proximate substantially concurrently with the mobile station initiating an outgoing wireless telephone call or receiving an incoming wireless telephone call,” Miyashita inherently discloses this limitation. As noted above for claim element [1f] which is incorporated herein by reference, Miyashita discloses that the display control portion 17 is responsive to inclination angle information from the gyro only “after talking is start[ed].” A person of ordinary skill in the art at the time of the alleged invention would understand that “initiating an outgoing wireless telephone call or receiving an incoming wireless telephone call” is how a talking is started. Further, a person of ordinary skill in the art at the time of the alleged invention would understand that “the proximity sensor begins detecting whether an external object is proximate substantially concurrently with the mobile station initiating an outgoing wireless telephone call or receiving an incoming wireless telephone call” because Miyashita discloses that this is when the display control portion

17 would be receptive to a signal from a sensor (such as a gyro or proximity sensor). Thus, a person of ordinary skill in the art at the time of the alleged invention would understand Miyashita to inherently disclose that “the proximity sensor begins detecting whether an external object is proximate substantially concurrently with the mobile station initiating an outgoing wireless telephone call or receiving an incoming wireless telephone call.”

To the extent Miyashita is deemed to not expressly or inherently disclose “the proximity sensor begins detecting whether an external object is proximate substantially concurrently with the mobile station initiating an outgoing wireless telephone call or receiving an incoming wireless telephone call,” Miyashita renders it obvious to one of skill in the art to have “the proximity sensor begin[] detecting whether an external object is proximate substantially concurrently with the mobile station initiating an outgoing wireless telephone call or receiving an incoming wireless telephone call.” A person of ordinary skill in the art at the time of the alleged invention would understand that “initiating an outgoing wireless telephone call or receiving an incoming wireless telephone call” is how a talking is started. Further, it would be obvious to a person of ordinary skill in the art at the time of the alleged invention for “the proximity sensor [to] begin[] detecting whether an external object is proximate substantially concurrently with the mobile station initiating an outgoing wireless telephone call or receiving an incoming wireless telephone call” because that is the only time when Miyashita discloses that the display control portion 17 would be receptive to a signal from a sensor (such as a gyro or proximity sensor). Because this is the only time that the signal is monitored, it would be obvious to a person of ordinary skill in the art at the time of the alleged invention that the proximity sensor should begin detecting substantially concurrently with the start of this period in order to save additional power.

To the extent Miyashita is deemed to not expressly or inherently disclose “the proximity sensor begins detecting whether an external object is proximate substantially concurrently with the mobile station initiating an outgoing wireless telephone call or receiving an incoming wireless telephone call,” it would be obvious to combine the

disclosure of Miyashita with those of Numazawa as described in the Numazawa claim chart, which is incorporated herein in its entirety by reference. Miyashita and Numazawa are both directed to conserving battery power in mobile stations generally and more particularly at conserving battery power in mobile stations by using sensors to detect when the user of the mobile station is in a call and unlikely to be looking at the display (as when, for example, the proximity sensor detects the user's ear by the mobile station or a sensor detects that the mobile station is in a vertical orientation) and to power off the display of mobile stations at such times. Miyashita at 3:58-4:2 (“In contrast, the display control portion 17 is responsive to the inclination angle information indicative of variation of the inclination angle from the substantially horizontal orientation to the substantially vertical orientation while it performs display control for the display portion 16 to display the control information, to terminate the power supply for the display portion 16. When speaking is performed with the destination person via the speaker 12 and the microphone 14, it is rare to require seeing the display content on the display portion 16. Therefore, the power supply for the display portion 16 is shut down. Thus, exhausting of a battery can be reduced.”); Numazawa at ¶ Abstract (“To achieve reduced power consumption through stopping operation of unnecessary functions during use of a wireless terminal. A CPU 2 identifies start of a call state through a signal from a signal processing portion 3 for controlling communication with a base station, and identifies, through an output signal from detecting means 6, whether or not a user ear is in contact with a terminal. Upon identification of contact of the ear to the terminal, controlling means 8 are caused to stop the supply of electric power, from a power supply 7, to displaying means 9 for providing information to a user, and lighting means 10, such as a black light.”), ¶ 0005-0007 (“In the present invention, control is such that, upon determination that the wireless terminal is in a call, operation of functions believe be unnecessary, due to the user of the terminal being in a call, is stopped, and upon termination of the call, operation of the stopped functions is restarted. Additionally, because it is envisioned that there will also be cases where, even during a call, the face of the user may be separated from the receiver of the terminal, control is performed so as to enable restarting of the operations of the functions that had been stopped as unnecessary, through detecting whether or not the user of the terminal has the receiver in contact with an ear. The achievement of reduced power consumption through stopping operation of functions that become unnecessary in use of the terminal, as described

above, can be anticipated to have the effect of extending the life of the power supply, such as a battery.”). While Miyashita discloses a gyro, it would be obvious to one of ordinary skill in the art at the time of the alleged invention to modify Miyashita’s gyro to function in the same way as the proximity sensor in Numazawa as both sensors serve the same function (to serve as an indication that the mobile station’s display is unlikely to be viewed and can therefore be powered off). A person of ordinary skill in the art at the time of the alleged invention would therefore be motivated to modify Miyashita to have “the proximity sensor begin[] detecting whether an external object is proximate substantially concurrently with the mobile station initiating an outgoing wireless telephone call or receiving an incoming wireless telephone call” as disclosed in Numazawa because the proximity sensor does not need to be detecting when its output is not being monitored, and beginning detecting only during the period when the signal is being monitored would save additional power. The combination would constitute, at least, combining prior art elements according to known methods to yield predictable results, a simple substitution of one known element for another to obtain predictable results, the use of a known technique to improve similar devices in the same way, the application of a known technique to a known device ready for improvement to yield a predictable result, and obvious to try.

To the extent Miyashita is deemed to not expressly or inherently disclose “the proximity sensor begins detecting whether an external object is proximate substantially concurrently with the mobile station initiating an outgoing wireless telephone call or receiving an incoming wireless telephone call,” it would be obvious to combine the disclosure of Miyashita with those of Seo as described in the Seo claim chart, which is incorporated herein in its entirety by reference. Miyashita and Seo are both directed to conserving battery power in mobile stations generally and more particularly at conserving battery power in mobile stations by using sensors to detect when the user of the mobile station is in a call and unlikely to be looking at the display (as when, for example, the proximity sensor detects the user’s car by the mobile station or a sensor detects that the mobile station is in a vertical orientation) and to power off the display of mobile stations at such times. Miyashita at 3:58-4:2 (“In contrast, the display control portion 17 is responsive to the inclination angle information indicative of variation of

the inclination angle from the substantially horizontal orientation to the substantially vertical orientation while it performs display control for the display portion 16 to display the control information, to terminate the power supply for the display portion 16. When speaking is performed with the destination person via the speaker 12 and the microphone 14, it is rare to require seeing the display content on the display portion 16. Therefore, the power supply for the display portion 16 is shut down. Thus, exhausting of a battery can be reduced.’). Seo at 1:36-42 (“It is hence a primary object of the invention to present a novel cordless telephone capable of, by solving the above mentioned technical problems, stopping the display action by the display device while the handset is in service so as to minimize the wasteful consumption of the electric power supplied from the battery or the like.”), 3:64-4:5 (When the receiver 6 is not in contact with the user’s ear, the light emitting element 3 lights up at step n8. In this state, when the user touches the receiver 6 of the handset by the ear, it is detected by the piezoelectric element 7, and the detection signal is sent out to the control circuit 11. The control circuit 11, on the basis of this detection signal, sends out a stop signal to the driver 12. Thus, driving of the driver 12 is stopped, and the light emitting element 3 is extinguished at step n7.”); While Miyashita discloses a gyro, it would be obvious to one of ordinary skill in the art at the time of the alleged invention to modify Miyashita’s gyro to function in the same way as the proximity sensor in Seo as both sensors serve the same function (to serve as an indication that the mobile station’s display is unlikely to be viewed and can therefore be powered off). A person of ordinary skill in the art at the time of the alleged invention would therefore be motivated to modify Miyashita to have “the proximity sensor begin[] detecting whether an external object is proximate substantially concurrently with the mobile station initiating an outgoing wireless telephone call or receiving an incoming wireless telephone call” as disclosed in Seo because the proximity sensor does not need to be detecting when its output is not being monitored, and beginning detecting only during the period when the signal is being monitored would save additional power. The combination would constitute, at least, combining prior art elements according to known methods to yield predictable results, a simple substitution of one known element for another to obtain predictable results, the use of a known technique to improve similar devices in the same way, the application of a known technique to a known device ready for improvement to yield a predictable result, and obvious to try.

<p>[Claim 2] The mobile station of claim 1, wherein the microprocessor reduces power to the display only if (i) the microprocessor determines that a telephone call is active and (ii) the signal indicates the proximity of the external object.</p>	<p>Miyashita discloses the microprocessor reducing power to the display only if (i) the microprocessor determines that a telephone call is active and (ii) the signal indicates the proximity of the external object:</p> <p>For example:</p> <p><i>See</i> discussion of claim element 1(f), <i>supra</i>, which is incorporated herein by reference.</p>
<p>[Claim 4] The mobile station as recited in claim 1, wherein the microprocessor reduces power to the display by turning off the display.</p>	<p>Miyashita discloses the microprocessor reducing power to the display by turning off the display:</p> <p>For example:</p> <p>“In contrast, the display control portion 17 is responsive to the inclination angle information indicative of variation of the inclination angle from the substantially horizontal orientation to the substantially vertical orientation while it performs display control for the display portion 16 to display the control information, to terminate the power supply for the display portion 16.</p> <p>When speaking is performed with the destination person via the speaker 12 and the microphone 14, it is rare to require seeing the display content on the display portion 16. Therefore, the power supply for the display portion 16 is shut down. Thus, exhausting of a battery can be reduced.” Miyashita at 3:58-4:2.</p>

“Thus, according to the shown embodiment, when the inclination angle information indicative that the main body is in a substantially horizontal orientation and when the reception control command from the reception control portion 2 and the call origination control command from the call origination control portion 3, the display control portion 17 starts the supply of the power. After speaking is started, when the inclination angle information indicative of a variation of orientation of the main body from the horizontal position to the vertical position, the display control portion shuts off power supply for the display portion 16. Therefore, in the state of the portable telephone set in which the display portion 16 will not be seen, no power will be supplied to the display portion 16. Therefore, power consumption can be reduced. As well, it should serve for reducing the depletion of the battery.” Miyashita at 4:30-45.

See discussion of claim element 1(f), *supra*, which is incorporated herein by reference.

To the extent Miyashita is deemed to not expressly or inherently disclose “the microprocessor reduces power to the display by turning off the display,” Miyashita renders it obvious to one of ordinary skill in the art at the time of the alleged invention. Miyashita discloses a gyro that indicates the inclination angle (vertical vs. horizontal) of the mobile station for the purpose of indicating whether a user is likely looking or not looking at the display of the mobile station and/or talking on the mobile station. *See* Miyashita at 3:46-4:2 (“The gyro 18 detects an inclination of a main body the portable telephone set to provide information concerning an inclination angle to the display control portion 17. The display control portion 17 receives the inclination angle information from the gyro 18. The display control portion 17 is responsive to the inclination angle information indicative of a substantially horizontal orientation of the main body and to one of reception control command from the reception control portion 2 and a call origination control command from the call origination control portion 3, to control a power source to supply a power to the display portion 16. In contrast, the display control portion 17 is responsive to the inclination angle information indicative of variation of the inclination angle from the substantially horizontal orientation to the substantially vertical orientation while it performs display control for the display portion 16 to display the control information, to terminate the

power supply for the display portion 16. When speaking is performed with the destination person via the speaker 12 and the microphone 14, it is rare to require seeing the display content on the display portion 16. Therefore, the power supply for the display portion 16 is shut down. Thus, exhausting of a battery can be reduced.”). A person of ordinary skill in the art at the time of the alleged invention would have understood that various sensors can be used in a mobile station for the purpose of indicating whether a user is likely looking or not looking at the display of the mobile station and/or talking on the mobile station. *See, e.g.,* Perez at ¶ 0022 (“[T]he step of detecting a talk condition can be achieved by monitoring or detecting at least one among the conditions of a) detecting if a predetermined volume of acoustic sound is being received at a microphone indicative of a user talking on the portable communication device; b) measuring at least one among a spectrum density and a spectrum energy of a bounced signal to determine the proximity of a user’s head to an earpiece of the portable communication device; c) measuring a predetermined period after a phone call starts; d) detecting an angle at which the portable communication device is positioned; e) detecting a vibration of the portable communication device; or f) detecting if the portable communication device is in a user’s hand. How the method 50 can detect the conditions described above can be embodied in many different forms using individually or in combination sensors and timers and other devices”). A person of ordinary skill in the art at the time of the alleged invention would therefore have understood that the invention of Miyashita could be performed using a proximity sensor instead of or in addition to a gyro for the purpose of indicating whether a user is likely looking or not looking at the display of the mobile station and/or talking on the mobile station. As described above, and in elements [1b]-[1e], which are incorporated herein by reference, Miyashita already teaches at least a microprocessor adapted to (c) reduce power to the display if (i) the microprocessor determines that a telephone call is active and (ii) the gyro indicates the mobile station is in a vertical orientation. It would therefore be obvious and a person of ordinary skill in the art at the time of the invention would be motivated to reduce power to the display by turning off the display. Doing so would be a design choice driven by a number of different reasons, including that it would support Miyashita’s ability to conserve battery power in mobile stations, and would be within the knowledge and ability of a person of ordinary skill in the art at the time of the alleged invention. Doing so would constitute, at least, combining prior art elements according to known methods to yield predictable results, a simple

substitution of one known element for another to obtain predictable results, the use of a known technique to improve similar devices in the same way, the application of a known technique to a known device ready for improvement to yield a predictable result, and obvious to try.

To the extent Miyashita is deemed to not expressly or inherently disclose “the microprocessor reduces power to the display by turning off the display,” it would be obvious to combine the disclosure of Miyashita with those of Numazawa as described in the Numazawa claim chart, which is incorporated herein in its entirety by reference. Miyashita and Numazawa are both directed to conserving battery power in mobile stations generally and more particularly at conserving battery power in mobile stations by using sensors to detect when the user of the mobile station is in a call and unlikely to be looking at the display (as when, for example, the proximity sensor detects the user’s ear by the mobile station or a sensor detects that the mobile station is in a vertical orientation) and to power off the display of mobile stations at such times. Miyashita at 1:58-63 (“The present invention is directed to solving the problem set forth above. It is therefore an object of the present invention to provide a portable telephone set which can shut off the power supply for a display portion while a content of the display will not be seen during speaking, and thus can reduce power consumption.”), 2:6-11 (“In the preferred construction the detector is a gyro. The control apparatus may shut off the power supply for the display when the detector detects the main body at a substantially vertical position. On the other hand, the control may initiate power supply for the display when the detector detects the main body at a substantially horizontal position.”); Numazawa at ¶ Abstract (“To achieve reduced power consumption through stopping operation of unnecessary functions during use of a wireless terminal. A CPU 2 identifies start of a call state through a signal from a signal processing portion 3 for controlling communication with a base station, and identifies, through an output signal from detecting means 6, whether or not a user ear is in contact with a terminal. Upon identification of contact of the ear to the terminal, controlling means 8 are caused to stop the supply of electric power, from a power supply 7, to displaying means 9 for providing information to a user, and lighting means 10, such as a black light.”), ¶ 0005-0007 (“In the present invention, control is such that, upon determination that the

wireless terminal is in a call, operation of functions believe be unnecessary, due to the user of the terminal being in a call, is stopped, and upon termination of the call, operation of the stopped functions is restarted. Additionally, because it is envisioned that there will also be cases where, even during a call, the face of the user may be separated from the receiver of the terminal, control is performed so as to enable restarting of the operations of the functions that had been stopped as unnecessary, through detecting whether or not the user of the terminal has the receiver in contact with an ear. The achievement of reduced power consumption through stopping operation of functions that become unnecessary in use of the terminal, as described above, can be anticipated to have the effect of extending the life of the power supply, such as a battery.”). A person of ordinary skill in the art at the time of the alleged invention would be motivated to modify Miyashita such that its microprocessor reduces power to the display by turning off the display, as disclosed in Numazawa for a number of different reasons, including that it would support Miyashita’s ability to conserve battery power in mobile stations, and doing so would be within the knowledge and ability of a person of ordinary skill in the art at the time of the alleged invention. The combination would constitute, at least, combining prior art elements according to known methods to yield predictable results, a simple substitution of one known element for another to obtain predictable results, the use of a known technique to improve similar devices in the same way, the application of a known technique to a known device ready for improvement to yield a predictable result, and obvious to try.

To the extent Miyashita is deemed to not expressly or inherently “the microprocessor reduces power to the display by turning off the display,” it would be obvious to combine the disclosure of Miyashita with those of Perez as described in the Perez claim chart, which is incorporated herein in its entirety by reference. Miyashita and Perez are both directed to conserving battery power in mobile stations generally and more particularly at conserving battery power in mobile stations by using sensors to detect when the user of the mobile station is in a call and unlikely to be looking at the display (as when, for example, the proximity sensor detects the user’s ear by the mobile station or a sensor detects that the mobile station is in a vertical orientation) and to power off the display of mobile stations at such times. Miyashita at 1:58-63 (“The present

invention is directed to solving the problem set forth above. It is therefore an object of the present invention to provide a portable telephone set which can shut off the power supply for a display portion while a content of the display will not be seen during speaking, and thus can reduce power consumption.”), 2:6-11 (“In the preferred construction the detector is a gyro. The control apparatus may shut off the power supply for the display when the detector detects the main body at a substantially vertical position. On the other hand, the control may initiate power supply for the display when the detector detects the main body at a substantially horizontal position.”); Perez at ¶ 0013 (“Referring to FIG. 1, a portable communication product 10 such as a cellular phone includes a transmitter radio having a microphone 20, an earpiece 22, a keypad 18 and a display 12 (such as a color display) coupled to the transmitter radio. The portable communication product 10 further includes at least one sensor (24, 26, 28 or 30) and a processor 16. The sensor can be used for detecting a user condition of the portable communication device such as a talk condition when the user is assumed to be talking on the portable communication device. The processor 16 can be programmed to at least reduce power provided to the display 12 when the sensor detects the talk condition. The processor 16 can also turn off power to the display 12 during a talk condition if desired.”). A person of ordinary skill in the art at the time of the alleged invention would be motivated to modify Miyashita to “reduce[] power to the display by turning off the display,” as disclosed in Perez for a number of different reasons, including that it would support Miyashita’s ability to conserve battery power in mobile stations, and doing so would be within the knowledge and ability of a person of ordinary skill in the art at the time of the alleged invention. The combination would constitute, at least, combining prior art elements according to known methods to yield predictable results, a simple substitution of one known element for another to obtain predictable results, the use of a known technique to improve similar devices in the same way, the application of a known technique to a known device ready for improvement to yield a predictable result, and obvious to try.

To the extent Miyashita is deemed to not expressly or inherently disclose “the microprocessor reduces power to the display by turning off the display,” it would be obvious to combine the disclosure of Miyashita with those of Seo as described in the

Seo claim chart, which is incorporated herein in its entirety by reference. Miyashita and Seo are both directed to conserving battery power in mobile stations generally and more particularly at conserving battery power in mobile stations by using sensors to detect when the user of the mobile station is in a call and unlikely to be looking at the display (as when, for example, the proximity sensor detects the user's ear by the mobile station or a sensor detects that the mobile station is in a vertical orientation) and to power off the display of mobile stations at such times. Miyashita at 1:58-63 ("The present invention is directed to solving the problem set forth above. It is therefore an object of the present invention to provide a portable telephone set which can shut off the power supply for a display portion while a content of the display will not be seen during speaking, and thus can reduce power consumption."), 2:6-11 ("In the preferred construction the detector is a gyro. The control apparatus may shut off the power supply for the display when the detector detects the main body at a substantially vertical position. On the other hand, the control may initiate power supply for the display when the detector detects the main body at a substantially horizontal position."); Seo at 1:36-42 ("It is hence a primary object of the invention to present a novel cordless telephone capable of, by solving the above mentioned technical problems, stopping the display action by the display device while the handset is in service so as to minimize the wasteful consumption of the electric power supplied from the battery or the like."), 3:64-4:5 (When the receiver 6 is not in contact with the user's ear, the light emitting element 3 lights up at step n8. In this state, when the user touches the receiver 6 of the handset by the ear, it is detected by the piezoelectric element 7, and the detection signal is sent out to the control circuit 11. The control circuit 11, on the basis of this detection signal, sends out a stop signal to the driver 12. Thus, driving of the driver 12 is stopped, and the light emitting element 3 is extinguished at step n7."). A person of ordinary skill in the art at the time of the alleged invention would be motivated to modify Miyashita's processor to reduce power to the display by turning off the display, as disclosed in Seo, for a number of different reasons, including that it would support Miyashita's ability to conserve battery power in mobile stations, and doing so would be within the knowledge and ability of a person of ordinary skill in the art at the time of the alleged invention. The combination would constitute, at least, combining prior art elements according to known methods to yield predictable results, a simple substitution of one known element for another to obtain predictable results, the use of a known technique to improve similar devices in the

	<p>same way, the application of a known technique to a known device ready for improvement to yield a predictable result, and obvious to try.</p>
<p>[Claim 5] The mobile station as recited in claim 1, wherein the proximity sensor is a mechanical proximity sensor, an optical sensor, or a range-detecting sensor.</p>	<p>Miyashita discloses that the proximity sensor is a mechanical proximity sensor, an optical sensor, or a range-detecting sensor:</p> <p>For example:</p> <p><i>See</i> discussion of claim elements 1(b) and 1(e), <i>supra</i>, which is incorporated herein by reference.</p> <p>To the extent Miyashita is deemed to not expressly or inherently disclose “[t]he mobile station as recited in claim 1, wherein the proximity sensor is a mechanical proximity sensor, an optical sensor, or a range-detecting sensor” it would be obvious to combine the disclosure of Miyashita with those of Numazawa as described in the Numazawa claim chart, which is incorporated herein in its entirety by reference. Miyashita and Numazawa are both directed to conserving battery power in mobile stations generally and more particularly at conserving battery power in mobile stations by using sensors to detect when the user of the mobile station is in a call and unlikely to be looking at the display (as when, for example, the proximity sensor detects the user’s ear by the mobile station or a sensor detects that the mobile station is in a vertical orientation) and to power off the display of mobile stations at such times. Miyashita at 1:58-63 (“The present invention is directed to solving the problem set forth above. It is therefore an object of the present invention to provide a portable telephone set which can shut off the power supply for a display portion while a content of the display will not be seen during speaking, and thus can reduce power consumption.”), 2:6-11 (“In the preferred construction the detector is a gyro. The control apparatus may shut off the power</p>

supply for the display when the detector detects the main body at a substantially vertical position. On the other hand, the control may initiate power supply for the display when the detector detects the main body at a substantially horizontal position.”); Numazawa at ¶ Abstract (“To achieve reduced power consumption through stopping operation of unnecessary functions during use of a wireless terminal. A CPU 2 identifies start of a call state through a signal from a signal processing portion 3 for controlling communication with a base station, and identifies, through an output signal from detecting means 6, whether or not a user ear is in contact with a terminal. Upon identification of contact of the ear to the terminal, controlling means 8 are caused to stop the supply of electric power, from a power supply 7, to displaying means 9 for providing information to a user, and lighting means 10, such as a black light.”), ¶ 0005-0007 (“In the present invention, control is such that, upon determination that the wireless terminal is in a call, operation of functions believe be unnecessary, due to the user of the terminal being in a call, is stopped, and upon termination of the call, operation of the stopped functions is restarted. Additionally, because it is envisioned that there will also be cases where, even during a call, the face of the user may be separated from the receiver of the terminal, control is performed so as to enable restarting of the operations of the functions that had been stopped as unnecessary, through detecting whether or not the user of the terminal has the receiver in contact with an ear. The achievement of reduced power consumption through stopping operation of functions that become unnecessary in use of the terminal, as described above, can be anticipated to have the effect of extending the life of the power supply, such as a battery.”). A person of ordinary skill in the art at the time of the alleged invention would be motivated to modify Miyashita to use “[t]he mobile station as recited in claim 1, wherein the proximity sensor is a mechanical proximity sensor, an optical sensor, or a range-detecting sensor” as disclosed in Numazawa for a number of different reasons, including that it would support Miyashita’s ability to conserve battery power in mobile stations, and doing so would be within the knowledge and ability of a person of ordinary skill in the art at the time of the alleged invention. The combination would constitute, at least, combining prior art elements according to known methods to yield predictable results, a simple substitution of one known element for another to obtain predictable results, the use of a known technique to improve similar devices in

the same way, the application of a known technique to a known device ready for improvement to yield a predictable result, and obvious to try.

To the extent Miyashita is deemed to not expressly or inherently disclose “[t]he mobile station as recited in claim 1, wherein the proximity sensor is a mechanical proximity sensor, an optical sensor, or a range-detecting sensor,” it would be obvious to combine the disclosure of Miyashita with those of Perez as described in the Perez claim chart, which is incorporated herein in its entirety by reference. Miyashita and Perez are both directed to conserving battery power in mobile stations generally and more particularly at conserving battery power in mobile stations by using sensors to detect when the user of the mobile station is in a call and unlikely to be looking at the display (as when, for example, the proximity sensor detects the user’s ear by the mobile station or a sensor detects that the mobile station is in a vertical orientation) and to power off the display of mobile stations at such times. Miyashita at 1:58-63 (“The present invention is directed to solving the problem set forth above. It is therefore an object of the present invention to provide a portable telephone set which can shut off the power supply for a display portion while a content of the display will not be seen during speaking, and thus can reduce power consumption.”), 2:6-11 (“In the preferred construction the detector is a gyro. The control apparatus may shut off the power supply for the display when the detector detects the main body at a substantially vertical position. On the other hand, the control may initiate power supply for the display when the detector detects the main body at a substantially horizontal position.”); Perez at ¶ 0013 (“Referring to FIG. 1, a portable communication product 10 such as a cellular phone includes a transceiver radio having a microphone 20, an earpiece 22, a keypad 18 and a display 12 (such as a color display) coupled to the transceiver radio. The portable communication product 10 further includes at least one sensor (24, 26, 28 or 30) and a processor 16. The sensor can be used for detecting a user condition of the portable communication device such as a talk condition when the user is assumed to be talking on the portable communication device. The processor 16 can be programmed to at least reduce power provided to the display 12 when the sensor detects the talk condition. The processor 16 can also turn off power to the display 12 during a talk condition if desired.”). A person of ordinary skill in the art at the time of the alleged invention would be motivated to

modify Miyashita to use “[t]he mobile station as recited in claim 1, wherein the proximity sensor is a mechanical proximity sensor, an optical sensor, or a range-detecting sensor,” as disclosed in Perez for a number of different reasons, including that it would support Miyashita’s ability to conserve battery power in mobile stations, and doing so would be within the knowledge and ability of a person of ordinary skill in the art at the time of the alleged invention. The combination would constitute, at least, combining prior art elements according to known methods to yield predictable results, a simple substitution of one known element for another to obtain predictable results, the use of a known technique to improve similar devices in the same way, the application of a known technique to a known device ready for improvement to yield a predictable result, and obvious to try.

To the extent Miyashita is deemed to not expressly or inherently disclose “[t]he mobile station as recited in claim 1, wherein the proximity sensor is a mechanical proximity sensor, an optical sensor, or a range-detecting sensor,” it would be obvious to combine the disclosure of Miyashita with those of Seo as described in the Seo claim chart, which is incorporated herein in its entirety by reference. Miyashita and Seo are both directed to conserving battery power in mobile stations generally and more particularly at conserving battery power in mobile stations by using sensors to detect when the user of the mobile station is in a call and unlikely to be looking at the display (as when, for example, the proximity sensor detects the user’s ear by the mobile station or a sensor detects that the mobile station is in a vertical orientation) and to power off the display of mobile stations at such times. Miyashita at 1:58-63 (“The present invention is directed to solving the problem set forth above. It is therefore an object of the present invention to provide a portable telephone set which can shut off the power supply for a display portion while a content of the display will not be seen during speaking, and thus can reduce power consumption.”), 2:6-11 (“In the preferred construction the detector is a gyro. The control apparatus may shut off the power supply for the display when the detector detects the main body at a substantially vertical position. On the other hand, the control may initiate power supply for the display when the detector detects the main body at a substantially horizontal position.”); Seo at 1:36-42 (“It is hence a primary object of the invention to present a novel cordless telephone capable of, by

	<p>solving the above mentioned technical problems, stopping the display action by the display device while the handset is in service so as to minimize the wasteful consumption of the electric power supplied from the battery or the like.”), 3:64-4:5 (When the receiver 6 is not in contact with the user's ear, the light emitting element 3 lights up at step n8. In this state, when the user touches the receiver 6 of the handset by the ear, it is detected by the piezoelectric element 7, and the detection signal is sent out to the control circuit 11. The control circuit 11, on the basis of this detection signal, sends out a stop signal to the driver 12. Thus, driving of the driver 12 is stopped, and the light emitting element 3 is extinguished at step n7.”). A person of ordinary skill in the art at the time of the alleged invention would be motivated to modify Miyashita to use “[t]he mobile station as recited in claim 1, wherein the proximity sensor is a mechanical proximity sensor, an optical sensor, or a range-detecting sensor,” as disclosed in Seo for a number of different reasons, including that it would support Miyashita’s ability to conserve battery power in mobile stations, and doing so would be within the knowledge and ability of a person of ordinary skill in the art at the time of the alleged invention. The combination would constitute, at least, combining prior art elements according to known methods to yield predictable results, a simple substitution of one known element for another to obtain predictable results, the use of a known technique to improve similar devices in the same way, the application of a known technique to a known device ready for improvement to yield a predictable result, and obvious to try.</p>
<p>[Claim 6] The mobile station as recited in claim 1, wherein the proximity sensor is located proximate to the display.</p>	<p>Miyashita discloses that the proximity sensor is located proximate to the display:</p> <p>For example:</p> <p><i>See</i> discussion of claim elements 1(b) and 1(e), <i>supra</i>, which is incorporated herein by reference.</p>

To the extent Miyashita is deemed to not expressly or inherently disclose “[t]he mobile station as recited in claim 1, wherein the proximity sensor is located proximate to the display,” it would be obvious to combine the disclosure of Miyashita with those of Numazawa as described in the Numazawa claim chart, which is incorporated herein in its entirety by reference. Miyashita and Numazawa are both directed to conserving battery power in mobile stations generally and more particularly at conserving battery power in mobile stations by using sensors to detect when the user of the mobile station is in a call and unlikely to be looking at the display (as when, for example, the proximity sensor detects the user’s ear by the mobile station or a sensor detects that the mobile station is in a vertical orientation) and to power off the display of mobile stations at such times. Miyashita at 1:58-63 (“The present invention is directed to solving the problem set forth above. It is therefore an object of the present invention to provide a portable telephone set which can shut off the power supply for a display portion while a content of the display will not be seen during speaking, and thus can reduce power consumption.”), 2:6-11 (“In the preferred construction the detector is a gyro. The control apparatus may shut off the power supply for the display when the detector detects the main body at a substantially vertical position. On the other hand, the control may initiate power supply for the display when the detector detects the main body at a substantially horizontal position.”); Numazawa at ¶ Abstract (“To achieve reduced power consumption through stopping operation of unnecessary functions during use of a wireless terminal. A CPU 2 identifies start of a call state through a signal from a signal processing portion 3 for controlling communication with a base station, and identifies, through an output signal from detecting means 6, whether or not a user ear is in contact with a terminal. Upon identification of contact of the ear to the terminal, controlling means 8 are caused to stop the supply of electric power, from a power supply 7, to displaying means 9 for providing information to a user, and lighting means 10, such as a black light.”), ¶ 0005-0007 (“In the present invention, control is such that, upon determination that the wireless terminal is in a call, operation of functions believe be unnecessary, due to the user of the terminal being in a call, is stopped, and upon termination of the call, operation of the stopped functions is restarted. Additionally, because it is envisioned that there will also be cases where, even during a call, the face of the user may be separated from the receiver of the terminal,

control is performed so as to enable restarting of the operations of the functions that had been stopped as unnecessary, through detecting whether or not the user of the terminal has the receiver in contact with an ear. The achievement of reduced power consumption through stopping operation of functions that become unnecessary in use of the terminal, as described above, can be anticipated to have the effect of extending the life of the power supply, such as a battery.”). A person of ordinary skill in the art at the time of the alleged invention would be motivated to modify Miyashita to use [t]he mobile station as recited in claim 1, wherein the proximity sensor is located proximate to the display” as disclosed in Numazawa for a number of different reasons, including that it would support Miyashita’s ability to conserve battery power in mobile stations, and doing so would be within the knowledge and ability of a person of ordinary skill in the art at the time of the alleged invention. The combination would constitute, at least, combining prior art elements according to known methods to yield predictable results, a simple substitution of one known element for another to obtain predictable results, the use of a known technique to improve similar devices in the same way, the application of a known technique to a known device ready for improvement to yield a predictable result, and obvious to try.

To the extent Miyashita is deemed to not expressly or inherently disclose [t]he mobile station as recited in claim 1, wherein the proximity sensor is located proximate to the display,” it would be obvious to combine the disclosure of Miyashita with those of Perez as described in the Perez claim chart, which is incorporated herein in its entirety by reference. Miyashita and Perez are both directed to conserving battery power in mobile stations generally and more particularly at conserving battery power in mobile stations by using sensors to detect when the user of the mobile station is in a call and unlikely to be looking at the display (as when, for example, the proximity sensor detects the user’s ear by the mobile station or a sensor detects that the mobile station is in a vertical orientation) and to power off the display of mobile stations at such times. Miyashita at 1:58-63 (“The present invention is directed to solving the problem set forth above. It is therefore an object of the present invention to provide a portable telephone set which can shut off the power supply for a display portion while a content of the display will not be seen during speaking, and thus can reduce power

consumption.”), 2:6-11 (“In the preferred construction the detector is a gyro. The control apparatus may shut off the power supply for the display when the detector detects the main body at a substantially vertical position. On the other hand, the control may initiate power supply for the display when the detector detects the main body at a substantially horizontal position.”); Perez at ¶ 0013 (“Referring to FIG. 1, a portable communication product 10 such as a cellular phone includes a transceiver radio having a microphone 20, an earpiece 22, a keypad 18 and a display 12 (such as a color display) coupled to the transceiver radio. The portable communication product 10 further includes at least one sensor (24, 26, 28 or 30) and a processor 16. The sensor can be used for detecting a user condition of the portable communication device such as a talk condition when the user is assumed to be talking on the portable communication device. The processor 16 can be programmed to at least reduce power provided to the display 12 when the sensor detects the talk condition. The processor 16 can also turn off power to the display 12 during a talk condition if desired.”). A person of ordinary skill in the art at the time of the alleged invention would be motivated to modify Miyashita to use “[t]he mobile station as recited in claim 1, wherein the proximity sensor is located proximate to the display” as disclosed in Perez for a number of different reasons, including that it would support Miyashita’s ability to conserve battery power in mobile stations, and doing so would be within the knowledge and ability of a person of ordinary skill in the art at the time of the alleged invention. The combination would constitute, at least, combining prior art elements according to known methods to yield predictable results, a simple substitution of one known element for another to obtain predictable results, the use of a known technique to improve similar devices in the same way, the application of a known technique to a known device ready for improvement to yield a predictable result, and obvious to try.

To the extent Miyashita is deemed to not expressly or inherently disclose “[t]he mobile station as recited in claim 1, wherein the proximity sensor is located proximate to the display,” it would be obvious to combine the disclosure of Miyashita with those of Seo as described in the Seo claim chart, which is incorporated herein in its entirety by reference. Miyashita and Seo are both directed to conserving battery power in mobile stations generally and more particularly at conserving battery power in mobile stations

by using sensors to detect when the user of the mobile station is in a call and unlikely to be looking at the display (as when, for example, the proximity sensor detects the user's ear by the mobile station or a sensor detects that the mobile station is in a vertical orientation) and to power off the display of mobile stations at such times. Miyashita at 1:58-63 (“The present invention is directed to solving the problem set forth above. It is therefore an object of the present invention to provide a portable telephone set which can shut off the power supply for a display portion while a content of the display will not be seen during speaking, and thus can reduce power consumption.”), 2:6-11 (“In the preferred construction the detector is a gyro. The control apparatus may shut off the power supply for the display when the detector detects the main body at a substantially vertical position. On the other hand, the control may initiate power supply for the display when the detector detects the main body at a substantially horizontal position.”); Seo at 1:36-42 (“It is hence a primary object of the invention to present a novel cordless telephone capable of, by solving the above mentioned technical problems, stopping the display action by the display device while the handset is in service so as to minimize the wasteful consumption of the electric power supplied from the battery or the like.”), 3:64-4:5 (When the receiver 6 is not in contact with the user's ear, the light emitting element 3 lights up at step n8. In this state, when the user touches the receiver 6 of the handset by the ear, it is detected by the piezoelectric element 7, and the detection signal is sent out to the control circuit 11. The control circuit 11, on the basis of this detection signal, sends out a stop signal to the driver 12. Thus, driving of the driver 12 is stopped, and the light emitting element 3 is extinguished at step n7.”). A person of ordinary skill in the art at the time of the alleged invention would be motivated to modify Miyashita to use “[t]he mobile station as recited in claim 1, wherein the proximity sensor is located proximate to the display,” as disclosed in Seo for a number of different reasons, including that it would support Miyashita's ability to conserve battery power in mobile stations, and doing so would be within the knowledge and ability of a person of ordinary skill in the art at the time of the alleged invention. The combination would constitute, at least, combining prior art elements according to known methods to yield predictable results, a simple substitution of one known element for another to obtain predictable results, the use of a known technique to improve similar devices in the same way, the application of a known

	<p>technique to a known device ready for improvement to yield a predictable result, and obvious to try.</p>
<p>[Claim 8 – Preamble] 8. A method of conserving battery power in a mobile station, comprising:</p>	<p>To the extent the preamble is construed as limiting, Miyashita discloses a method of conserving battery power in a mobile station:</p> <p>For example:</p> <p><i>See</i> discussion of claim 1, <i>supra</i>, which is incorporated herein by reference.</p> <p>“In contrast, the display control portion 17 is responsive to the inclination angle information indicative of variation of the inclination angle from the substantially horizontal orientation to the substantially vertical orientation while it performs display control for the display portion 16 to display the control information, to terminate the power supply for the display portion 16.</p> <p>When speaking is performed with the destination person via the speaker 12 and the microphone 14, it is rare to require seeing the display content on the display portion 16. Therefore, the power supply for the display portion 16 is shut down. Thus, exhausting of a battery can be reduced.” Miyashita at 3:58-4:2.</p> <p>“Thus, according to the shown embodiment, when the inclination angle information indicative that the main body is in a substantially horizontal orientation and when the reception control command from the reception control portion 2 and the call origination control command from the call origination control portion 3, the display control portion 17 starts the supply of the power. After speaking is started, when the inclination angle information indicative of a variation of orientation of the main body</p>

<p>[8a] detecting whether an external object is proximate;</p>	<p>from the horizontal position to the vertical position, the display control portion shuts off power supply for the display portion 16. Therefore, in the state of the portable telephone set in which the display portion 16 will not be seen, no power will be supplied to the display portion 16. Therefore, power consumption can be reduced. As well, it should serve for reducing the depletion of the battery.” Miyashita at 4:30-45.</p>
<p>[8a] detecting whether an external object is proximate;</p>	<p>Miyashita discloses detecting whether an external object is proximate:</p> <p>For example:</p> <p><i>See</i> discussion of claim element [1b], <i>supra</i>, which is incorporated herein by reference.</p> <p>To the extent Miyashita is deemed to not expressly disclose this claim limitation, Miyashita inherently discloses this limitation. <i>See</i> discussion of claim element [1b], <i>supra</i>, which is incorporated herein by reference.</p> <p>To the extent Miyashita is deemed to not expressly or inherently disclose this claim limitation, Miyashita renders it obvious to one of skill in the art at the time of the alleged invention. <i>See</i> discussion of claim element [1b], <i>supra</i>, which is incorporated herein by reference.</p> <p>To the extent Miyashita is deemed to not expressly or inherently disclose this claim element, it would be obvious to combine the disclosure of Miyashita with those of Numazawa as described in the Numazawa claim chart, which is incorporated herein in its entirety by reference. <i>See</i> discussion of claim element [1b], <i>supra</i>, which is incorporated herein by reference.</p> <p>To the extent Miyashita is deemed to not expressly or inherently disclose this claim element, it would be obvious to combine the disclosure of Miyashita with those of Perez as described in the Perez claim chart, which is incorporated herein in its entirety</p>

	<p>by reference. <i>See</i> discussion of claim element [1b], <i>supra</i>, which is incorporated herein by reference.</p> <p>To the extent Miyashita is deemed to not expressly or inherently disclose this claim element, it would be obvious to combine the disclosure of Miyashita with those of Seo as described in the Seo claim chart, which is incorporated herein in its entirety by reference. <i>See</i> discussion of claim element [1b], <i>supra</i>, which is incorporated herein by reference.</p>
<p>[8b] determining whether a telephone call is active; and</p>	<p>Miyashita discloses determining whether a telephone call is active:</p> <p>For example:</p> <p><i>See</i> discussion of claim element 1(d), <i>supra</i>, which is incorporated herein by reference.</p>
<p>[8c] reducing power consumption of a display of the mobile station if (i) a telephone call is determined to be active and (ii) the proximity of the external object is detected; wherein:</p>	<p>Miyashita discloses reducing power consumption of a display of the mobile station if (i) a telephone call is determined to be active and (ii) the proximity of the external object is detected:</p> <p>For example:</p> <p><i>See</i> discussion of claim element 1(f), <i>supra</i>, which is incorporated herein by reference.</p> <p>To the extent Miyashita is deemed to not expressly disclose this claim limitation, Miyashita inherently discloses this limitation. <i>See</i> discussion of claim element [1f], <i>supra</i>, which is incorporated herein by reference.</p>

	<p>To the extent Miyashita is deemed to not expressly or inherently disclose this claim limitation, Miyashita renders it obvious to one of skill in the art at the time of the alleged invention. <i>See</i> discussion of claim element [1f], <i>supra</i>, which is incorporated herein by reference.</p> <p>To the extent Miyashita is deemed to not expressly or inherently disclose this claim element, it would be obvious to combine the disclosure of Miyashita with those of Numazawa as described in the Numazawa claim chart, which is incorporated herein in its entirety by reference. <i>See</i> discussion of claim element [1f], <i>supra</i>, which is incorporated herein by reference.</p> <p>To the extent Miyashita is deemed to not expressly or inherently disclose this claim element, it would be obvious to combine the disclosure of Miyashita with those of Perez as described in the Perez claim chart, which is incorporated herein in its entirety by reference. <i>See</i> discussion of claim element [1f], <i>supra</i>, which is incorporated herein by reference.</p> <p>To the extent Miyashita is deemed to not expressly or inherently disclose this claim element, it would be obvious to combine the disclosure of Miyashita with those of Seo as described in the Seo claim chart, which is incorporated herein in its entirety by reference. <i>See</i> discussion of claim element [1f], <i>supra</i>, which is incorporated herein by reference.</p>
<p>[8d] the telephone call is a wireless telephone call;</p>	<p>Miyashita discloses that the telephone call is a wireless telephone call:</p> <p>For example:</p> <p><i>See</i> discussion of claim element 1 (g), <i>supra</i>, which is incorporated herein by reference.</p>

[8e] the power consumption of the display is reduced while the proximity of the external object is detected only if the wireless telephone call is determined to be active; and

Miyashita discloses that the power consumption of the display is reduced while the proximity of the external object is detected only if the wireless telephone call is determined to be active:

For example:

See discussion of claim element 1(f), *supra*, which is incorporated herein by reference.

To the extent Miyashita is deemed to not expressly disclose this claim limitation, Miyashita inherently discloses this limitation. *See* discussion of claim element [1f], *supra*, which is incorporated herein by reference.

To the extent Miyashita is deemed to not expressly or inherently disclose this claim limitation, Miyashita renders it obvious to one of skill in the art at the time of the alleged invention. *See* discussion of claim element [1f], *supra*, which is incorporated herein by reference.

To the extent Miyashita is deemed to not expressly or inherently disclose this claim element, it would be obvious to combine the disclosure of Miyashita with those of Numazawa as described in the Numazawa claim chart, which is incorporated herein in its entirety by reference. *See* discussion of claim element [1f], *supra*, which is incorporated herein by reference.

To the extent Miyashita is deemed to not expressly or inherently disclose this claim element, it would be obvious to combine the disclosure of Miyashita with those of Perez as described in the Perez claim chart, which is incorporated herein in its entirety by reference. *See* discussion of claim element [1f], *supra*, which is incorporated herein by reference.

To the extent Miyashita is deemed to not expressly or inherently disclose this claim element, it would be obvious to combine the disclosure of Miyashita with those of Seo as described in the Seo claim chart, which is incorporated herein in its entirety by

	<p>reference. <i>See</i> discussion of claim element [1f], <i>supra</i>, which is incorporated herein by reference.</p>
<p>[8f] detecting whether an external object is proximate begins substantially concurrently with the mobile station initiating an outgoing wireless telephone call or receiving an incoming wireless telephone call.</p>	<p>Miyashita discloses that detecting whether an external object is proximate begins substantially concurrently with the mobile station initiating an outgoing wireless telephone call or receiving an incoming wireless telephone call:</p> <p>For example:</p> <p><i>See</i> discussion of claim element 1(i), <i>supra</i>, which is incorporated herein by reference.</p> <p>To the extent Miyashita is deemed to not expressly disclose this claim limitation, Miyashita inherently discloses this limitation. <i>See</i> discussion of claim element [1i], <i>supra</i>, which is incorporated herein by reference.</p> <p>To the extent Miyashita is deemed to not expressly or inherently disclose this claim limitation, Miyashita renders it obvious to one of skill in the art at the time of the alleged invention. <i>See</i> discussion of claim element [1i], <i>supra</i>, which is incorporated herein by reference.</p> <p>To the extent Miyashita is deemed to not expressly or inherently disclose this claim element, it would be obvious to combine the disclosure of Miyashita with those of Numazawa as described in the Numazawa claim chart, which is incorporated herein in its entirety by reference. <i>See</i> discussion of claim element [1i], <i>supra</i>, which is incorporated herein by reference.</p> <p>To the extent Miyashita is deemed to not expressly or inherently disclose this claim element, it would be obvious to combine the disclosure of Miyashita with those of Perez as described in the Perez claim chart, which is incorporated herein in its entirety</p>

	<p>by reference. <i>See</i> discussion of claim element [1], <i>supra</i>, which is incorporated herein by reference.</p> <p>To the extent Miyashita is deemed to not expressly or inherently disclose this claim element, it would be obvious to combine the disclosure of Miyashita with those of Seo as described in the Seo claim chart, which is incorporated herein in its entirety by reference. <i>See</i> discussion of claim element [1], <i>supra</i>, which is incorporated herein by reference.</p>
<p>[Claim 12] The method as recited in claim 8, wherein the detecting of the proximity of the external object is performed by a mechanical proximity sensor, an optical sensor, or a range-detecting sensor.</p>	<p>Miyashita discloses that the detecting of the proximity of the external object is performed by a mechanical proximity sensor, an optical sensor, or a range-detecting sensor:</p> <p>For example:</p> <p><i>See</i> discussion of claim 5, <i>supra</i>, which is incorporated herein by reference.</p>

Exhibit A4

**Exhibit A4 - Seo
to Defendants' Preliminary Invalidity Contentions**

**Invalidity Chart for U.S. Patent No. 7,319,889
U.S. Patent No. 5,010,566 ("Seo")**

U.S. Patent No. 5,010,566 to Seo ("Seo") was filed on September 7, 1989 and issued on April 23, 1991. Seo is prior art to the '889 Patent under at least pre-AIA 35 U.S.C. §§ 102(a), 102(b), and 102(e). Seo anticipates or renders obvious, alone or in combination with other prior art references, each of the Asserted Claims of the '889 Patent as described in the chart below and in the main invalidity contentions document to which this chart is annexed.

It would have been obvious under 35 U.S.C. § 103 to a person having ordinary skill in the art at the time of the alleged invention to combine the teachings of Seo with the following references:

1. Japanese Unexamined Patent Application Publication No. 2000-106598 to Fukiharu ("Fukiharu 598"). Fukiharu 598 qualifies as prior art under at least pre-AIA §§ 102(a), 102(b), and 102(e). Fukiharu 598 was published on April 11, 2000.
2. Japanese Unexamined Patent Application Publication No. H11-220432 ("Numazawa"). Numazawa qualifies as prior art under at least pre-AIA §§ 102(a), 102(b), and 102(e). Numazawa was published on August 10, 1999.
3. U.S. Patent No. 5,586,182 to Miyashita ("Miyashita"). Miyashita qualifies as prior art under at least pre-AIA 35 U.S.C. § 102(e). Miyashita was filed on May 1, 1995 and issued on December 17, 1996.

<u>Asserted Claims</u>	<u>Corresponding Disclosure in the Prior Art Reference(s)</u>
[Claim 1 – Preamble] 1. A mobile station, comprising:	<p>Seo discloses a mobile station.</p> <p>For example: "A cordless telephone includes a base unit connected to a telephone line so as to communicate by radio waves for talking and a handset. The handset includes a speaker, a microphone, and a transmitting and receiving circuit for communicating with the base unit by radio waves, transforming the signals from the caller into acoustic sound by the speaker, and sending the output from the microphone to the caller. The handset further includes a battery for providing the transmitting and receiving circuit with electric power. Still further, the handset includes a device for display to indicate the in-service state, a device for detecting the contact of the speaker area with a part of the body, a device for detecting talking to detect the in-service state, and a device for controlling to stop the display action of the display device when the speaker area is in contact with a part of the body and is in service this stopping of the display device</p>

occurs response to the output from the contact detecting device and the talk detecting device. The control device further affects the display action by the display device while the speaker area is not in contact with the body during service. The handset, in this device, is electrically powered by a battery.” See at Abstract.

“The present invention relates to a cordless telephone having a base unit connected to a communication line such as telephone line, and a handset connected to the base unit by radio communication and furnished with a device for display so as to indicate that the handset is in service.” See at 1:6-12.

“The invention also relates to a cordless telephone having a base unit connected to a telephone line and a handset connected to the base unit through radio communication and equipped with a device for display so as to indicate the in-service state by the handset by the display device, which includes.” See at 2:16-22.

“FIG. 1 is a perspective view showing the entire structure of a cordless telephone 21 according to an embodiment of the invention. The cordless telephone 21 is connected to a telephone line 22, and include a handset 25 and a base unit 23 for radio communication therewith, the base unit 23 having an antenna 24 for radio communication with the handset 25. The handset 25 includes key switches 2 such as numeric keys as a dial input device provided inside the grip of a handset unit 1; a light emitting element 3 as a display device composed of a light emitting diode (LED) or the like disposed in the vicinity of the key switches 2 inside the grip; a disconnect or hang-up button 4 as the talk completion device for changing over between line capturing state and talk waiting state; a transmitter 5 with a microphone 14 built in and located near the mouth of the user; a receiver 6 containing a piezoelectric element 7 known as touch sensor or the like as the contact detecting device when contacting with the ear, that is, a part of the body of the user contacted while talking; an antenna 8 for communicating with the base unit 23; and a battery 28.” See at 3:1-22.

Fig 1

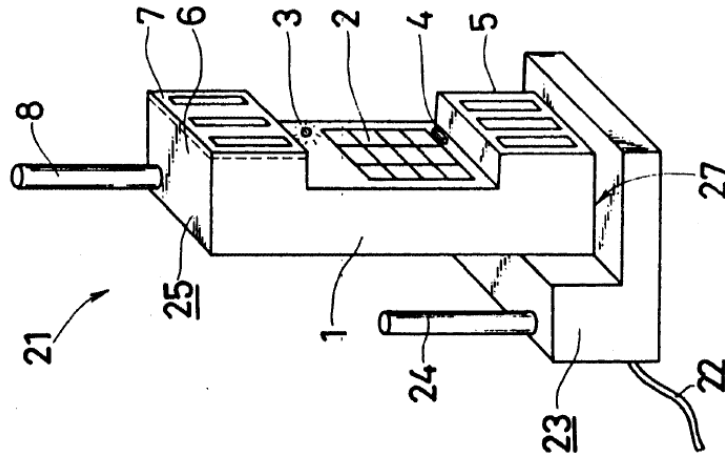

See at Fig. 1.

“FIG. 2 is a block diagram showing a schematic electrical construction of the cordless telephone 21.

In this diagram, a key signal by the operation of the key switch 2 is given to a control circuit 11 which is a device for controlling the members in the handset 25. It is also sent out from the antenna 8 through a transmitting and receiving circuit 13, and is

received through the antenna 24 of the base unit 23. It is then sent out to the telephone at the destination through the telephone line 22. Further, by the key signal from the key switch 2, the control circuit 11 sends out a drive signal to a driver 12 for lighting up the light emitting element 3. Thus, the driver 12 is driven to light up the light emitting element 3. In the meantime, a signal from the piezoelectric element 7 is applied to the control circuit 11, and a stop signal is sent out to the driver 12 from this piezoelectric element 7. Thus, driving of the driver 12 is stopped to extinguish the light emitting element 3. At the same time, the control circuit 11 sends out a control signal to the transmitting and receiving circuit 13. The transmitting and receiving circuit 13 amplifies and modulates the transmission signal received from a microphone 5 built in the transmitter 5. It then sends out a signal from the antenna 8, and demodulates and amplifies the reception signal sent from the antenna 23 through the telephone line 22 which is a communication circuit. Finally, it sends out a signal to a speaker 15 built in the receiver 6. Thus, an acoustic signal is delivered from the speaker 15. Such a handset 25 is electrically powered by a built-in battery 28." Seo at 3:23-52.

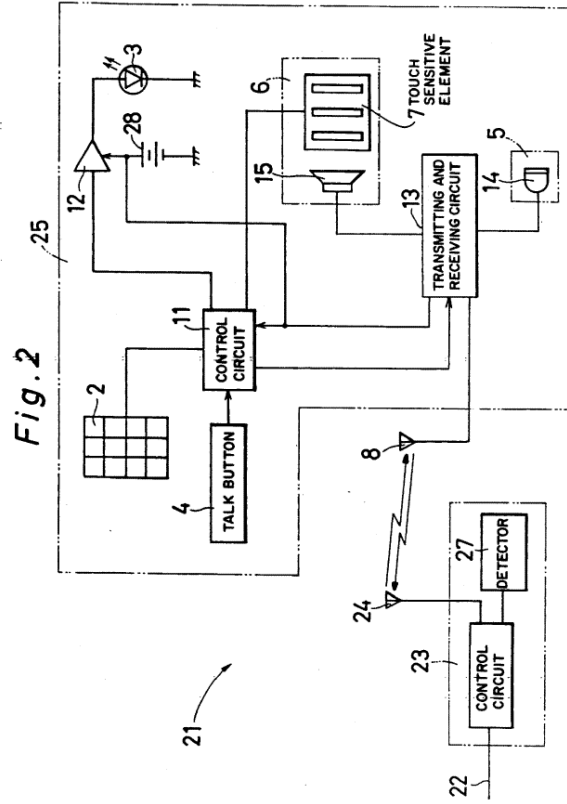

See at Fig. 2.

“1. A cordless telephone apparatus including a base unit connected to a telephone line for communication, and a handset, operatively connected to the base unit by radio waves, including a speaker, a microphone, a transmitting and receiving circuit for communicating with the base unit by radio waves, transforming the signals from a caller into acoustic sound by the speaker, and second the output from the microphone to the caller, and a battery for providing the transmitting and receiving circuit with electric power, the handset further comprising:

display means for indicating an in-service state of the cordless telephone activated for communication;

contact detecting means for detecting contact of a user with an area proximate to the speaker;

activation detecting means for detecting activation of the cordless telephone for communications to detect the in-service state; and

control means operatively connected to the display means, the contact detecting means and the activation detecting means, for controlling the display means to stop indicating an in-service state when an area proximate to the speaker is detected to be in contact with a user and an in service state is detected, in response to the contact detecting means and activation detecting means, and for controlling the display means to indicate an in-service state when an area proximate to the speaker is not detected to be in contact with a user and an in service state is detected; and

the handset battery means for electrically powering the handset.” Seo at claim 1.

“6. A cordless telephone apparatus including a base unit connected to a telephone line and a handset operatively connected to the base unit via radio communication and equipped with a display device for indicating an in-service state of the handset, the handset comprising:

contact detecting means for detecting contact when a part of the body of the user contacts with an area proximate to a speaker of the handset, and

stopping means for stopping the display device from indicating the in-service state when a part of the body of the user is detected to be in contact with an area proximate to the speaker of the handset, in response to the contact detecting means.” Seo at claim 6.

“7. A handset of a cordless telephone including a base unit and the handset including a speaker and a transmitter for communicating, by radio communications, with the base unit, the handset further comprising:

display means for displaying indication of the cordless telephone being in-service;

detecting means for emitting a signal upon detecting contact of a user to an area of the handset in close proximity to the speaker; and

control means, operatively connected to said display means and said detecting means, for controlling said display means to display indication of the cordless telephone being in-service upon not receiving an output signal from said detecting means when the cordless telephone is in service and for controlling said display means to stop displaying indication of the cordless telephone being in-service upon receiving an output signal from the detecting means when the cordless telephone is in service.” Seo at claim 7.

“16. A method of conserving power of a battery in a cordless telephone, including a handset with a battery, a speaker and a receiver and further including a base unit, which indicates to a user when the cordless telephone is in-service, comprising the steps of:

(a) displaying indication, on the handset, of the cordless telephone in-service;

(b) supplying power from the battery during said step (a) of displaying;

(c) detecting contact of a user to an area of the handset in close proximity to the speaker;

(d) inhibiting said step (a) of displaying by stopping said step (b) of supplying power upon detecting contact in step (c) to thus conserve battery power while said telephone is in-service.” Seo at claim 16.

To the extent Seo is deemed to not expressly disclose a mobile station, Seo inherently discloses this limitation. For example, as recognized in the 889 patent itself, “[m]obile stations have found many uses in today’s world. When paired with a single base station located at a user’s own premises, they are called ‘cordless telephones.’ When they interact with various, geographically distributed cellular base stations, they are called ‘cellular telephones’ or simply ‘cell phones.’” U.S. Patent No. 7,319,889 (“the ‘889 patent”). A person of ordinary skill in the art at the time of the alleged invention would understand that cordless telephone 21, as described in Seo, is necessarily a mobile station.

To the extent Seo is deemed to not expressly or inherently disclose a mobile station, Seo renders this limitation obvious to a person of ordinary skill in the art at the time of the alleged invention. Seo discloses a “cordless telephone” that “includes a base unit connected to a telephone line so as to communicate by radio waves....” Seo at Abstract. Furthermore, as recognized in the 889 patent itself, “[m]obile stations have found many uses in today’s world. When paired with a single base station located at a user’s own premises, they are called ‘cordless telephones.’ When they interact with various, geographically distributed cellular base stations, they are called ‘cellular telephones’ or simply ‘cell phones.’” U.S. Patent No. 7,319,889 (“the ‘889 patent”). Seo also discloses a method of conserving the battery power of the handset of the cordless phone. Seo at 1:36-42 (“It is hence a primary object of the invention to present a novel cordless telephone capable of, by solving the above mentioned technical problems, stopping the display action by the display device while the handset is in service so as to minimize the wasteful consumption of the electric power supplied from the battery or the like.”). It would therefore be obvious to a person of ordinary skill in the art at the time of the alleged invention to use Seo’s methods for conserving battery power for any type of mobile station (whether it be a “cordless telephone” or

“cellular telephone”). Such a combination would constitute, at least, combining prior art elements according to known methods to yield predictable results, a simple substitution of one known element for another to obtain predictable results, the use of a known technique to improve similar devices in the same way, the application of a known technique to a known device ready for improvement to yield a predictable result, and obvious to try.

To the extent Seo is deemed to not expressly or inherently disclose a “mobile station,” it would be obvious to combine the disclosure of Seo with those of Fukihara 598 as described in the Fukihara 598 claim chart, which is incorporated herein in its entirety by reference. Seo and Fukihara 598 are both directed to conserving battery power in mobile stations generally and more particularly at conserving battery power in mobile stations by using sensors to detect when the user of the mobile station is in a call and unlikely to be looking at the display (as when, for example, the proximity sensor detects the user’s ear by the mobile station) and to power off the display of mobile stations at such times. Seo at 1:36-42 (“It is hence a primary object of the invention to present a novel cordless telephone capable of, by solving the above mentioned technical problems, stopping the display action by the display device while the handset is in service so as to minimize the wasteful consumption of the electric power supplied from the battery or the like.”), 3:64-4:5 (When the receiver 6 is not in contact with the user’s ear, the light emitting element 3 lights up at step n8. In this state, when the user touches the receiver 6 of the handset by the ear, it is detected by the piezoelectric element 7, and the detection signal is sent out to the control circuit 11. The control circuit 11, on the basis of this detection signal, sends out a stop signal to the driver 12. Thus, driving of the driver 12 is stopped, and the light emitting element 3 is extinguished at step n7.”); Fukiharu 598 at ¶ 0018 (“The present invention, through the use of a structure as described above, enables a reduction in the consumption of battery power, through enabling the lighting devices to be turned OFF when the ear is caused to contact the receiver portion in order to hear the receiver sound during voice communications of a mobile telephone when the lighting devices (backlights) for a liquid crystal display device and keypad portion of a mobile telephone are lit, such as that night.”). A person of ordinary skill in the art at the time of the alleged invention

would be motivated to modify Seo to apply its battery conserving method to the mobile station disclosed in Fukihara 598 for a number of different reasons, including that it would support Seo's ability to conserve battery power in mobile stations, and doing so would be within the knowledge and ability of a person of ordinary skill in the art at the time of the alleged invention. The combination would constitute, at least, combining prior art elements according to known methods to yield predictable results, a simple substitution of one known element for another to obtain predictable results, the use of a known technique to improve similar devices in the same way, the application of a known technique to a known device ready for improvement to yield a predictable result, and obvious to try.

To the extent Seo is deemed to not expressly or inherently disclose a "mobile station," it would be obvious to combine the disclosure of Seo with those of Numazawa as described in the Numazawa claim chart, which is incorporated herein in its entirety by reference. Seo and Numazawa are both directed to conserving battery power in mobile stations generally and more particularly at conserving battery power in mobile stations by using sensors to detect when the user of the mobile station is in a call and unlikely to be looking at the display (as when, for example, the proximity sensor detects the user's ear by the mobile station) and to power off the display of mobile stations at such times. Seo at 1:36-42 ("It is hence a primary object of the invention to present a novel cordless telephone capable of, by solving the above mentioned technical problems, stopping the display action by the display device while the handset is in service so as to minimize the wasteful consumption of the electric power supplied from the battery or the like."), 3:64-4:5 (When the receiver 6 is not in contact with the user's ear, the light emitting element 3 lights up at step n8. In this state, when the user touches the receiver 6 of the handset by the ear, it is detected by the piezoelectric element 7, and the detection signal is sent out to the control circuit 11. The control circuit 11, on the basis of this detection signal, sends out a stop signal to the driver 12. Thus, driving of the driver 12 is stopped, and the light emitting element 3 is extinguished at step n7."); Numazawa at ¶ Abstract ("To achieve reduced power consumption through stopping operation of unnecessary functions during use of a wireless terminal. A CPU 2 identifies start of a call state through a signal from a signal processing portion 3 for

controlling communication with a base station, and identifies, through an output signal from detecting means 6, whether or not a user ear is in contact with a terminal. Upon identification of contact of the ear to the terminal, controlling means 8 are caused to stop the supply of electric power, from a power supply 7, to displaying means 9 for providing information to a user, and lighting means 10, such as a black light.”), ¶ 0005-0007 (“In the present invention, control is such that, upon determination that the wireless terminal is in a call, operation of functions believe be unnecessary, due to the user of the terminal being in a call, is stopped, and upon termination of the call, operation of the stopped functions is restarted. Additionally, because it is envisioned that there will also be cases where, even during a call, the face of the user may be separated from the receiver of the terminal, control is performed so as to enable restarting of the operations of the functions that had been stopped as unnecessary, through detecting whether or not the user of the terminal has the receiver in contact with an ear. The achievement of reduced power consumption through stopping operation of functions that become unnecessary in use of the terminal, as described above, can be anticipated to have the effect of extending the life of the power supply, such as a battery.”). A person of ordinary skill in the art at the time of the alleged invention would be motivated to modify Seo to apply its battery conserving method to the mobile station disclosed in Numazawa for a number of different reasons, including that it would support Seo’s ability to conserve battery power in mobile stations, and doing so would be within the knowledge and ability of a person of ordinary skill in the art at the time of the alleged invention. The combination would constitute, at least, combining prior art elements according to known methods to yield predictable results, a simple substitution of one known element for another to obtain predictable results, the use of a known technique to improve similar devices in the same way, the application of a known technique to a known device ready for improvement to yield a predictable result, and obvious to try.

To the extent Seo is deemed to not expressly or inherently disclose a “mobile station,” it would be obvious to combine the disclosure of Seo with those of Miyashita as described in the Miyashita claim chart, which is incorporated herein in its entirety by reference. Seo and Miyashita are both directed to conserving battery power in mobile

stations generally and more particularly at conserving battery power in mobile stations by using sensors to detect when the user of the mobile station is in a call and unlikely to be looking at the display (as when, for example, the proximity sensor detects the user's ear by the mobile station or a sensor detects that the mobile station is in a vertical orientation) and to power off the display of mobile stations at such times. Seo at 1:36-42 ("It is hence a primary object of the invention to present a novel cordless telephone capable of, by solving the above mentioned technical problems, stopping the display action by the display device while the handset is in service so as to minimize the wasteful consumption of the electric power supplied from the battery or the like."), 3:64-4:5 ("When the receiver 6 is not in contact with the user's ear, the light emitting element 3 lights up at step n8. In this state, when the user touches the receiver 6 of the handset by the ear, it is detected by the piezoelectric element 7, and the detection signal is sent out to the control circuit 11. The control circuit 11, on the basis of this detection signal, sends out a stop signal to the driver 12. Thus, driving of the driver 12 is stopped, and the light emitting element 3 is extinguished at step n7."); Miyashita at 1:58-63 ("The present invention is directed to solving the problem set forth above. It is therefore an object of the present invention to provide a portable telephone set which can shut off the power supply for a display portion while a content of the display will not be seen during speaking, and thus can reduce power consumption."), 2:6-11 ("In the preferred construction the detector is a gyro. The control apparatus may shut off the power supply for the display when the detector detects the main body at a substantially vertical position. On the other hand, the control may initiate power supply for the display when the detector detects the main body at a substantially horizontal position."). A person of ordinary skill in the art at the time of the alleged invention would be motivated to modify Seo to apply its battery conserving method to the mobile station disclosed in Miyashita for a number of different reasons, including that it would support Seo's ability to conserve battery power in mobile stations, and doing so would be within the knowledge and ability of a person of ordinary skill in the art at the time of the alleged invention. The combination would constitute, at least, combining prior art elements according to known methods to yield predictable results, a simple substitution of one known element for another to obtain predictable results, the use of a known technique to improve similar devices in the same way, the application of a known

	<p>technique to a known device ready for improvement to yield a predictable result, and obvious to try.</p>
<p>[1a] a display;</p>	<p>Seo discloses a display.</p> <p>For example: “Still further, the handset includes a device for display to indicate the in-service state, a device for detecting the contact of the speaker area with a part of the body, a device for detecting talking to detect the in-service state, and a device for controlling to stop the display action of the display device when the speaker area is in contact with a part of the body and is in service this stopping of the display device occurs response to the output from the contact detecting device and the talk detecting device. The control device further affects the display action by the display device while the speaker area is not in contact with the body during service. The handset, in this device, is electrically powered by a battery.” Seo at Abstract.</p> <p>“The present invention relates to a cordless telephone having a base unit connected to a communication line such as telephone line, and a handset connected to the base unit by radio communication and furnished with a device for display so as to indicate that the handset is in service.” Seo at 1:6-12.</p> <p>“In this case, therefore, the end of a call cannot be confirmed by the handset in the conventional method, and in the hitherto cordless telephone, a pilot lamp is built in the handset as the device for display. This lamp is lit while the handset is in service. Further, by pressing the disconnect or hang up button on the handset after the call is complete, the pilot lamp goes out.” Seo at 1:19-27.</p> <p>“It is hence a primary object of the invention to present a novel cordless telephone capable of, by solving the above mentioned technical problems, stopping the display action by the display device while the handset is in service so as to minimize the wasteful consumption of the electric power supplied from the battery or the like.” Seo at 1:36-42.</p>

“To achieve the above object, the cordless telephone of the invention comprises:

...

- (c1) a device for display to indicate the in-service state,
- (c2) a device for detecting the contact of the speaker area with a part of the body,
- (c3) a device for detecting the talk to detect the in-service state, and
- (c4) a device for controlling to stop the display action of the display a device when the speaker area is in contact with a part of the body and is in service, in response to the output from the contact detecting device and talk detecting device, and to effect the display action by the display device while the speaker area is not in contact with the body during service, and
- (c5) the handset is electrically powered by the battery.

Preferably, the display device is a light emitting diode.” Seo at 1:43-2:4.

“The invention also relates to a cordless telephone having a base unit connected to a telephone line and a handset connected to the base unit through radio communication and equipped with a device for display so as to indicate the in-service state by the handset by the display device, which includes:

...

a device for stopping the display to stop the display action by the display device when a part of the body of the user is in contact with the area proximate to the speaker of the handset, in response to the detection signal from the contact detecting device.

According to invention, when the contact of a part of the body of the user with an area proximate to the speaker of the handset is detected by the contact detecting device, the display action of the display device is stopped by the display stopping device while a part of the body of the user is in contact with the area proximate to the speaker of the

handset. When the part of the body of the user is departed from the area proximate to the speaker of the handset, the display action of the display device is affected again.

Thus, according to the cordless telephone of the invention, while talking, as long as a part of the body of the user remains in contact with the area proximate to the handset, the display action by the display device is not affected to display the in-service state, so that the consumption of the battery while the handset is in service can be minimized.”
See at 2:16-47.

“FIG. 1 is a perspective view showing the entire structure of a cordless telephone 21 according to an embodiment of the invention. The cordless telephone 21 is connected to a telephone line 22, and include a handset 25 and a base unit 23 for radio communication therewith, the base unit 23 having an antenna 24 for radio communication with the handset 25. The handset 25 includes key switches 2 such as numeric keys as a dial input device provided inside the grip of a handset unit 1; a light emitting element 3 as a display device composed of a light emitting diode (LED) or the like disposed in the vicinity of the key switches 2 inside the grip; a disconnect or hang-up button 4 as the talk completion device for changing over between line capturing state and talk waiting state; a transmitter 5 with a microphone 14 built in and located near the mouth of the user; a receiver 6 containing a piezoelectric element 7 known as touch sensor or the like as the contact detecting device when contacting with the ear, that is, a part of the body of the user contacted while talking; an antenna 8 for communicating with the base unit 23; and a battery 28.” See at 3:1-22.

“1. A cordless telephone apparatus including a base unit connected to a telephone line for communication, and a handset, operatively connected to the base unit by radio waves, including a speaker, a microphone, a transmitting and receiving circuit for communicating with the base unit by radio waves, transforming the signals from a caller into acoustic sound by the speaker, and second the output from the microphone to the caller, and a battery for providing the transmitting and receiving circuit with electric power, the handset further comprising:

display means for indicating an in-service state of the cordless telephone activated for communication;

contact detecting means for detecting contact of a user with an area proximate to the speaker;

activation detecting means for detecting activation of the cordless telephone for communications to detect the in-service state; and

control means operatively connected to the display means, the contact detecting means and the activation detecting means, for controlling the display means to stop indicating an in-service state when an area proximate to the speaker is detected to be in contact with a user and an in-service state is detected, in response to the contact detecting means and activation detecting means, and for controlling the display means to indicate an in-service state when an area proximate to the speaker is not detected to be in contact with a user and an in-service state is detected; and

the handset battery means for electrically powering the handset.” Seo at claim 1.

“2. The cordless telephone apparatus of claim 1, wherein the display means is a light emitting diode.” Seo at claim 2.

“7. A handset of a cordless telephone including a base unit and the handset including a speaker and a transmitter for communicating, by radio communications, with the base unit, the handset further comprising:

display means for displaying indication of the cordless telephone being in-service;

detecting means for emitting a signal upon detecting contact of a user to an area of the handset in close proximity to the speaker; and

control means, operatively connected to said display means and said detecting means, for controlling said display means to display indication of the cordless telephone being in-service upon not receiving an output signal from said detecting means when the cordless telephone is in service and for controlling said display means to stop displaying indication of the cordless telephone being in-service upon receiving an output signal from the detecting means when the cordless telephone is in service.” Seo at claim 7.

“10. The handset of claim 7, wherein the display means is a light emitting diode (LED).” Seo at claim 10.

“14. The handset of claim 7, further comprising:

end of service means, operatively connected to said control means, for outputting a signal to the control means to indicate that the cordless telephone is not in-service, and wherein said control means, upon receipt of said output signal from said end of service means, controls said display means to stop displaying indication of the cordless telephone being in service.

15. The handset of claim 7, further comprising:

battery means, operatively connected to said display means for providing power to enable said display means to display in-service indication.”

16. A method of conserving power of a battery in a cordless telephone, including a handset with a battery, a speaker and a receiver and further including a base unit, which indicates to a user when the cordless telephone is in-service, comprising the steps of:

(a) displaying indication, on the handset, of the cordless telephone in-service;

(b) supplying power from the battery during said step (a) of displaying;

(c) detecting contact of a user to an area of the handset in close proximity to the speaker;

(d) inhibiting said step (a) of displaying by stopping said step (b) of supplying power upon detecting contact in step (c) to thus conserve battery power while said telephone is in-service.” Seo at claims 14-16.

“17. The method of claim 16, further comprising the step of:

	<p>(e) terminating said step (a) of displaying upon said telephone not being in-service.” See at claim 17.</p>
<p>[1b] a proximity sensor adapted to generate a signal indicative of proximity of an external object; and</p>	<p>See discloses a proximity sensor adapted to generate a signal indicative of proximity of an external object.</p> <p>For example: “To achieve the above object, the cordless telephone of the invention comprises:</p> <p>...</p> <p>(c) the handset further comprises:</p> <p>(c1) a device for display to indicate the in-service state,</p> <p>(c2) a device for detecting the contact of the speaker area with a part of the body,</p> <p>(c3) a device for detecting the talk to detect the in-service state, and</p> <p>(c4) a device for controlling to stop the display action of the display a device when the speaker area is in contact with a part of the body and is in service, in response to the output from the contact detecting device and talk detecting device, and to effect the display action by the display device while the speaker area is not in contact with the body during service, and</p> <p>(c5) the handset is electrically powered by the battery.</p> <p>...</p> <p>Also preferably, the contact detecting device is a piezoelectric element.” See at 1:43-2:8.</p> <p>“The invention also relates to a cordless telephone having a base unit connected to a telephone line and a handset connected to the base unit through radio communication and equipped with a device for display so as to indicate the in-service state by the handset by the display device, which includes:</p>

a device for detecting contact when a part of the body of the user contacts an area proximate to the speaker, and

a device for stopping the display to stop the display action by the display device when a part of the body of the user is in contact with the area proximate to the speaker of the handset, in response to the detection signal from the contact detecting device.

According to invention, when the contact of a part of the body of the user with an area proximate to the speaker of the handset is detected by the contact detecting device, the display action of the display device is stopped by the display stopping device while a part of the body of the user is in contact with the area proximate to the speaker of the handset. When the part of the body of the user is departed from the area proximate to the speaker of the handset, the display action of the display device is affected again.

Thus, according to the cordless telephone of the invention, while talking, as long as a part of the body of the user remains in contact with the area proximate to the handset, the display action by the display device is not affected to display the in-service state, so that the consumption of the battery while the handset is in service can be minimized.”
See at 2:16-47.

“FIG. 1 is a perspective view showing the entire structure of a cordless telephone 21 according to an embodiment of the invention...a receiver 6 containing a piezoelectric element 7 known as touch sensor or the like as the contact detecting device when contacting with the ear, that is, a part of the body of the user contacted while talking; an antenna 8 for communicating with the base unit 23; and a battery 28.” See at 3:1-22.”

Fig 1

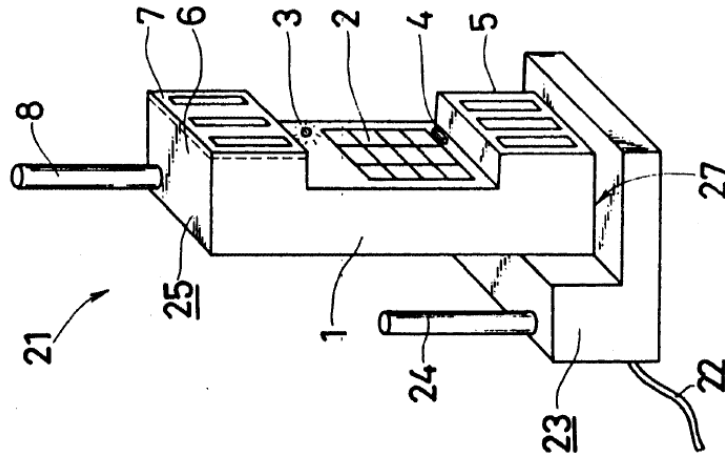

See at Fig. 1.

“FIG. 2 is a block diagram showing a schematic electrical construction of the cordless telephone 21.

In this diagram, a key signal by the operation of the key switch 2 is given to a control circuit 1 which is a device for controlling the members in the handset 25. It is also sent out from the antenna 8 through a transmitting and receiving circuit 13, and is

received through the antenna 24 of the base unit 23. It is then sent out to the telephone at the destination through the telephone line 22. Further, by the key signal from the key switch 2, the control circuit 11 sends out a drive signal to a driver 12 for lighting up the light emitting element 3. Thus, the driver 12 is driven to light up the light emitting element 3. In the meantime, a signal from the piezoelectric element 7 is applied to the control circuit 11, and a stop signal is sent out to the driver 12 from this piezoelectric element 7. Thus, driving of the driver 12 is stopped to extinguish the light emitting element 3. At the same time, the control circuit 11 sends out a control signal to the transmitting and receiving circuit 13. The transmitting and receiving circuit 13 amplifies and modulates the transmission signal received from a microphone 5 built in the transmitter 6. It then sends out a signal from the antenna 8, and demodulates and amplifies the reception signal sent from the antenna 23 through the telephone line 22 which is a communication circuit. Finally, it sends out a signal to a speaker 15 built in the receiver 6. Thus, an acoustic signal is delivered from the speaker 15. Such a handset 25 is electrically powered by a built-in battery 28." Seo at 3:23-52.

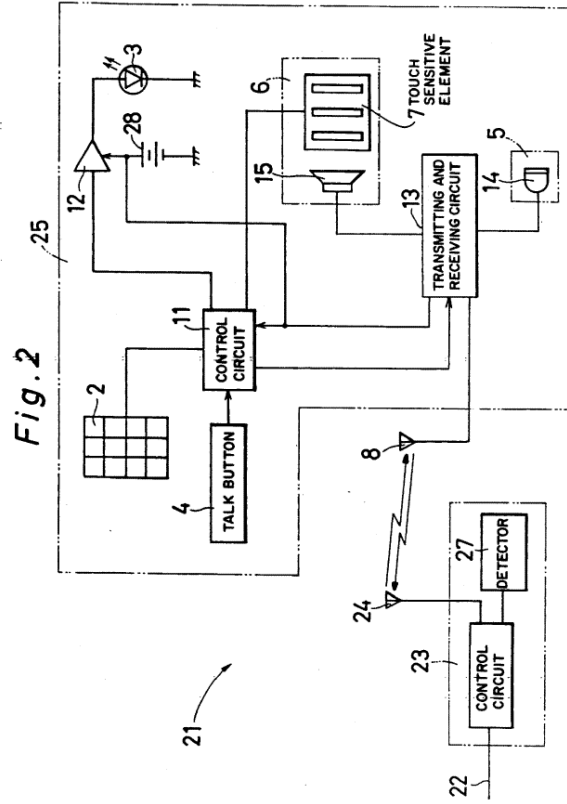

Seo at Fig. 2.

“At step n1 in FIG. 4, when the key switch 2 is operated and the telephone circuit 22 is connected at step n2, a drive signal is issued from the control circuit 11 to the driver 12. Further, when the talk button 4 is not pressed at step n3, the operation goes to step n5. Then when the line is busy, the operation advances to step n6. When the receiver 6 is not in contact with the user's ear, the light emitting element 3 lights up at step n8. In this state, when the user touches the receiver 6 of the handset by the ear, it is detected by the piezoelectric element 7, and the detection signal is sent out to the control circuit 11. The control circuit 11, on the basis of this detection signal, sends out a stop signal to the driver 12. Thus, driving of the driver 12 is stopped, and the light emitting element 3 is extinguished at step n7. Afterwards, when the user's ear is departed again from the piezoelectric element 7, the control circuit 11 then sends out a drive signal to the driver 12 to drive the driver 12. This thereby lights the light emitting element 3 again. Afterwards, by pressing the hang-up button 4 at step n3, a communication circuit cut-off signal is sent out from the handset 25 to the base unit 23 at step n4. Thus the base unit 23 receives the communication circuit signal at step m4 in FIG. 3. Then the connection with the telephone line 22 is cut off at step m5, so that the light emitting element 3 of the handset 25 goes out.” See at 3:59-4:16.

Fig. 3

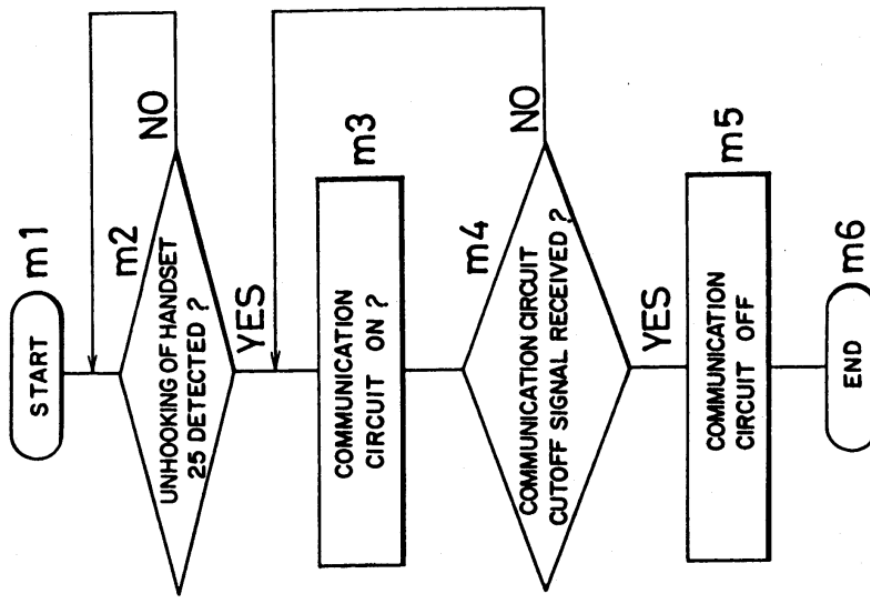

See at Fig. 3.

Fig. 4

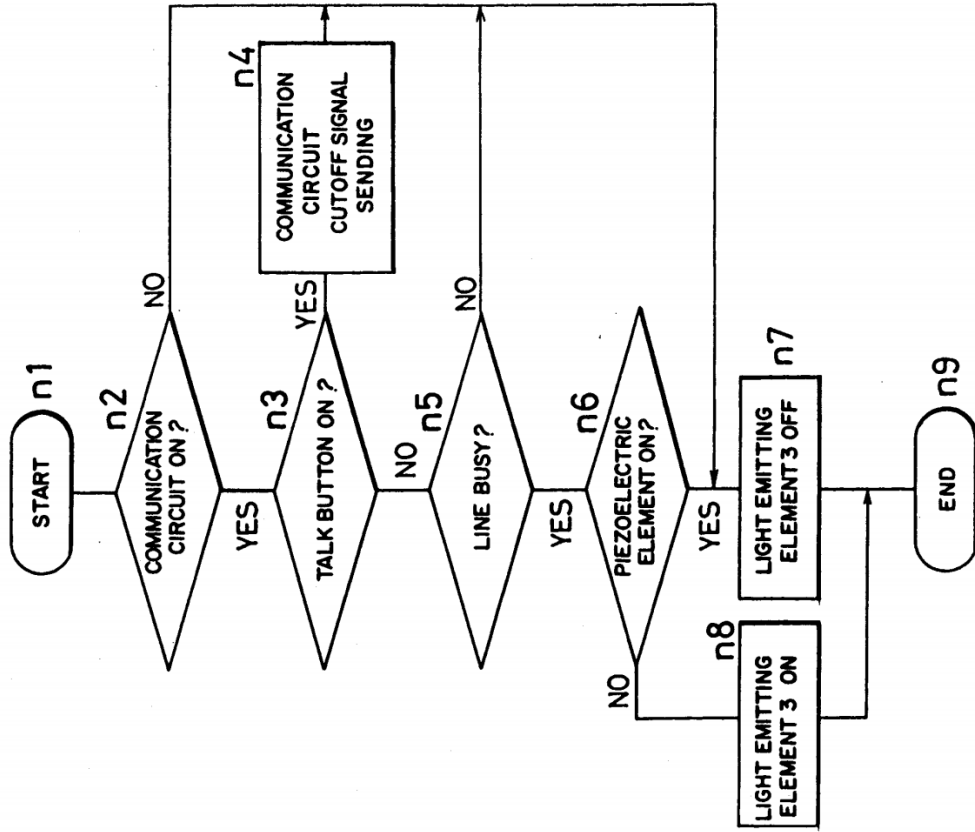

See at Fig. 4.

“1. A cordless telephone apparatus including a base unit connected to a telephone line for communication, and a handset, operatively connected to the base unit by radio waves, including a speaker, a microphone, a transmitting and receiving circuit for communicating with the base unit by radio waves, transforming the signals from a caller into acoustic sound by the speaker, and second the output from the microphone to the caller, and a battery for providing the transmitting and receiving circuit with electric power, the handset further comprising:

display means for indicating an in-service state of the cordless telephone activated for communication;

contact detecting means for detecting contact of a user with an area proximate to the speaker;

activation detecting means for detecting activation of the cordless telephone for communications to detect the in-service state; and

control means operatively connected to the display means, the contact detecting means and the activation detecting means, for controlling the display means to stop indicating an in-service state when an area proximate to the speaker is detected to be in contact with a user and an in service state is detected, in response to the contact detecting means and activation detecting means, and for controlling the display means to indicate an in-service state when an area proximate to the speaker is not detected to be in contact with a user and an in service state is detected; and

the handset battery means for electrically powering the handset.” Seo at claim 1.

“ 3. The cordless telephone apparatus of claim 1, wherein the contact detecting means is a piezoelectric element.” Seo at claim 3.

“5. The cordless telephone apparatus of claim 1, wherein the contact detecting means includes a penetration hole in an area proximate to the speaker, the speaker being disposed behind the contact detecting means.” Seo at claim 5.

<p>“6. A cordless telephone apparatus including a base unit connected to a telephone line and a handset operatively connected to the base unit via radio communication and equipped with a display device for indicating an in-service state of the handset, the handset comprising:</p> <p>contact detecting means for detecting contact when a part of the body of the user contacts with an area proximate to a speaker of the handset, and</p> <p>stopping means for stopping the display device from indicating the in-service state when a part of the body of the user is detected to be in contact with an area proximate to the speaker of the handset, in response to the contact detecting means.” See at claim 6.</p> <p>“7. A handset of a cordless telephone including a base unit and the handset including a speaker and a transmitter for communicating, by radio communications, with the base unit, the handset further comprising:</p> <p>display means for displaying indication of the cordless telephone being in-service;</p> <p>detecting means for emitting a signal upon detecting contact of a user to an area of the handset in close proximity to the speaker; and</p> <p>control means, operatively connected to said display means and said detecting means, for controlling said display means to display indication of the cordless telephone being in-service upon not receiving an output signal from said detecting means when the cordless telephone is in service and for controlling said display means to stop displaying indication of the cordless telephone being in-service upon receiving an output signal from the detecting means when the cordless telephone is in service.” See at claim 7.</p> <p>“9. The handset of claim 7, wherein the detecting means is a piezoelectric element and the piezoelectric element is disposed in close proximity to the speaker.” See at claim 9.</p> <p>“12. The handset of claim 11, wherein the detecting means is a piezoelectric element disposed in close proximity to the speaker.</p>	
---	--

13. The handset of claim 12, wherein the piezoelectric element detects contact of the user's ear to the handset, proximate to the speaker, and outputs a signal." Seo at claims 12-13.

"16. A method of conserving power of a battery in a cordless telephone, including a handset with a battery, a speaker and a receiver and further including a base unit, which indicates to a user when the cordless telephone is in-service, comprising the steps of:

(a) displaying indication, on the handset, of the cordless telephone in-service;

(b) supplying power from the battery during said step (a) of displaying;

(c) detecting contact of a user to an area of the handset in close proximity to the speaker;

(d) inhibiting said step (a) of displaying by stopping said step (b) of supplying power upon detecting contact in step (c) to thus conserve battery power while said telephone is in-service." Seo at claim 17.

"18. The method of claim 16, wherein said step (c) of detecting contact detects contact of a user's ear to an area of the handset in close proximity to the speaker." Seo at claim 18.

To the extent Seo is deemed to not expressly disclose "a proximity sensor adapted to generate a signal indicative of proximity of an external object," a person of skill would understand that this claim element is inherent in Seo's disclosure. Specifically, in disclosing "a device for stopping the display to stop the display action by the display device when a part of the body of the user is in contact with the area proximate to the speaker of the handset, in response to the detection signal from the contact detecting device," Seo necessarily discloses generating a signal indicative of proximity of an external object. *See* Seo at 2:25-29.

<p>[1c] a microprocessor adapted to:</p>	<p>Seo discloses a microprocessor.</p> <p>For example: “A cordless telephone includes a base unit connected to a telephone line so as to communicate by radio waves for talking and a handset. The handset includes a speaker, a microphone, and a transmitting and receiving circuit for communicating with the base unit by radio waves, transforming the signals from the caller into acoustic sound by the speaker, and sending the output from the microphone to the caller. The handset further includes a battery for providing the transmitting and receiving circuit with electric power. Still further, the handset includes a device for display to indicate the in-service state, a device for detecting the contact of the speaker area with a part of the body, a device for detecting talking to detect the in-service state, and a device for controlling to stop the display action of the display device when the speaker area is in contact with a part of the body and is in service this stopping of the display device occurs response to the output from the contact detecting device and the talk detecting device. The control device further affects the display action by the display device while the speaker area is not in contact with the body during service. The handset, in this device, is electrically powered by a battery.” Seo at Abstract.</p> <p>“FIG. 2 is a block diagram showing a schematic electrical construction of the cordless telephone 21.</p> <p>In this diagram, a key signal by the operation of the key switch 2 is given to a control circuit 11 which is a device for controlling the members in the handset 25. It is also sent out from the antenna 8 through a transmitting and receiving circuit 13, and is received through the antenna 24 of the base unit 23. It is then sent out to the telephone at the destination through the telephone line 22. Further, by the key signal from the key switch 2, the control circuit 11 sends out a drive signal to a driver 12 for lighting up the light emitting element 3. Thus, the driver 12 is driven to light up the light emitting element 3. In the meantime, a signal from the piezoelectric element 7 is applied to the control circuit 11, and a stop signal is sent out to the driver 12 from this piezoelectric element 7. Thus, driving of the driver 12 is stopped to extinguish the light emitting element 3. At the same time, the control circuit 11 sends out a control signal to the transmitting and receiving circuit 13. The transmitting and receiving circuit 13 amplifies</p>
--	---

and modulates the transmission signal received from a microphone 14 built in the transmitter 5. It then sends out a signal from the antenna 8, and demodulates and amplifies the reception signal sent from the base unit 23 through the telephone line 22 which is a communication circuit. Finally, it sends out a signal to a speaker 15 built in the receiver 6. Thus, an acoustic signal is delivered from the speaker 15 built in the handset 25 is electrically powered by a built-in battery 28." Seo at 3:23-52.

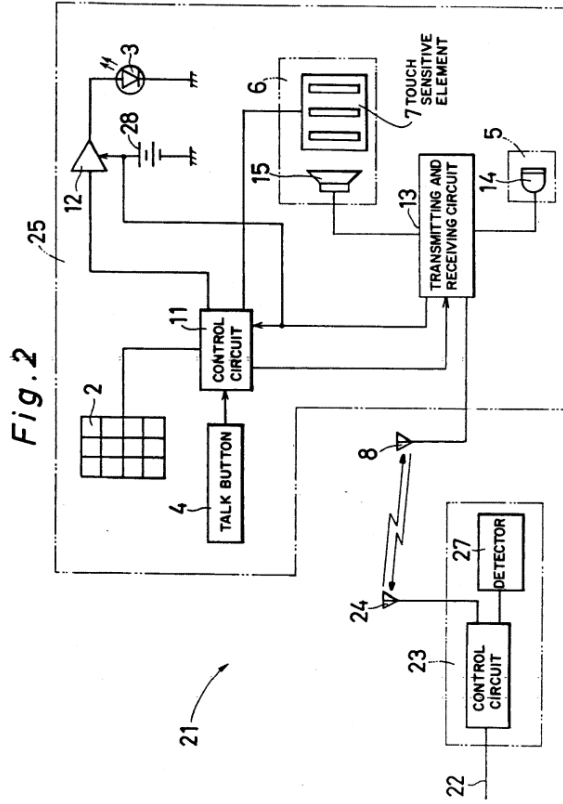

See at Fig. 2.

"At step n1 in FIG. 4, when the key switch 2 is operated and the telephone circuit 22 is connected at step n2, a drive signal is issued from the control circuit 11 to the driver 12. Further, when the talk button 4 is not pressed at step n3, the operation goes to step n5. Then when the line is busy, the operation advances to step n6. When the receiver 6 is not in contact with the user's ear, the light emitting element 3 lights up at step n8. In this state, when the user touches the receiver 6 of the handset by the ear, it is detected by the piezoelectric element 7, and the detection signal is sent out to the control circuit 11. The control circuit 11, on the basis of this detection signal, sends out a stop signal to the driver 12. Thus, driving of the driver 12 is stopped, and the light emitting

element 3 is extinguished at step n7. Afterwards, when the user's ear is departed again from the piezoelectric element 7, the control circuit 11 then sends out a drive signal to the driver 12 to drive the driver 12. This thereby lights the light emitting element 3 again. Afterwards, by pressing the hang-up button 4 at step n3, a communication circuit cut-off signal is sent out from the handset 25 to the base unit 23 at step n4. Thus the base unit 23 receives the communication circuit signal at step m4 in FIG. 3. Then the connection with the telephone line 22 is cut off at step m5, so that the light emitting element 3 of the handset 25 goes out." See at 3:59-4:17.

"1. A cordless telephone apparatus including a base unit connected to a telephone line for communication, and a handset, operatively connected to the base unit by radio waves, including a speaker, a microphone, a transmitting and receiving circuit for communicating with the base unit by radio waves, transforming the signals from a caller into acoustic sound by the speaker, and second the output from the microphone to the caller, and a battery for providing the transmitting and receiving circuit with electric power, the handset further comprising:

display means for indicating an in-service state of the cordless telephone activated for communication;

contact detecting means for detecting contact of a user with an area proximate to the speaker;

activation detecting means for detecting activation of the cordless telephone for communications to detect the in-service state; and

control means operatively connected to the display means, the contact detecting means and the activation detecting means, for controlling the display means to stop indicating an in-service state when an area proximate to the speaker is detected to be in contact with a user and an in service state is detected, in response to the contact detecting means and activation detecting means, and for controlling the display means to indicate an in-service state when an area proximate to the speaker is not detected to be in contact with a user and an in service state is detected; and

the handset battery means for electrically powering the handset.” Seo at claim 1.

“7. A handset of a cordless telephone including a base unit and the handset including a speaker and a transmitter for communicating, by radio communications, with the base unit, the handset further comprising:

display means for displaying indication of the cordless telephone being in-service;

detecting means for emitting a signal upon detecting contact of a user to an area of the handset in close proximity to the speaker; and

control means, operatively connected to said display means and said detecting means, for controlling said display means to display indication of the cordless telephone being in-service upon not receiving an output signal from said detecting means when the cordless telephone is in service and for controlling said display means to stop displaying indication of the cordless telephone being in-service upon receiving an output signal from the detecting means when the cordless telephone is in service.” Seo at claim 7.

To the extent Seo is deemed to not expressly disclose a “microprocessor adapted to,” Seo inherently discloses this limitation. Seo discloses a mobile station with a control circuit 11. Microprocessors (such as the ARM7TDMI) were widely implemented in mobile stations at the time of the alleged invention as a control means. *See, e.g., S. Segars, “The ARM9 family—high performance microprocessors for embedded applications”, Proc. ICCD, pp. 230-235, 1998-Oct.* A person of ordinary skill in the art at the time of the alleged invention would therefore understand Seo to necessarily disclose a “microprocessor adapted to.”

To the extent Seo is deemed to not expressly or inherently disclose “a microprocessor adapted to,” Seo renders it obvious to one of skill in the art to use “a microprocessor adapted to.” A person of ordinary skill in the art at the time of the alleged invention would understand that the functionality of the control circuit 11 of Seo could be

implemented using a microprocessor such as the ARM7TDMI. *See, e.g.,* S. Segars, “The ARM9 family-high performance microprocessors for embedded applications”, Proc. ICCD, pp. 230-235, 1998-Oct. Doing so would be a design choice driven by a number of different reasons, including that it would support Seo’s ability to conserve battery power in mobile stations, and doing so would be within the knowledge and ability of a person of ordinary skill in the art at the time of the alleged invention. The use of a microprocessor would constitute, at least, combining prior art elements according to known methods to yield predictable results, a simple substitution of one known element for another to obtain predictable results, the use of a known technique to improve similar devices in the same way, the application of a known technique to a known device ready for improvement to yield a predictable result, and obvious to try.

To the extent Seo is deemed to not expressly or inherently disclose “a microprocessor adapted to,” it would be obvious to combine the disclosure of Seo with those of Fukihara 598 as described in the Fukihara 598 claim chart, which is incorporated herein in its entirety by reference. Seo and Fukihara 598 are both directed to conserving battery power in mobile stations generally and more particularly at conserving battery power in mobile stations by using sensors to detect when the user of the mobile station is in a call and unlikely to be looking at the display (as when, for example, the proximity sensor detects the user’s ear by the mobile station) and to power off the display of mobile stations at such times. Seo at 1:36-42 (“It is hence a primary object of the invention to present a novel cordless telephone capable of, by solving the above mentioned technical problems, stopping the display action by the display device while the handset is in service so as to minimize the wasteful consumption of the electric power supplied from the battery or the like.”), 3:64-4:5 (When the receiver 6 is not in contact with the user’s ear, the light emitting element 3 lights up at step n8. In this state, when the user touches the receiver 6 of the handset by the ear, it is detected by the piezoelectric element 7, and the detection signal is sent out to the control circuit 11. The control circuit 11, on the basis of this detection signal, sends out a stop signal to the driver 12. Thus, driving of the driver 12 is stopped, and the light emitting element 3 is extinguished at step n7.”); Fukiharu 598 at ¶ 0018 (“The present invention, through the use of a structure as described above, enables a reduction in the consumption of

battery power, through enabling the lighting devices to be turned OFF when the ear is caused to contact the receiver portion in order to hear the receiver sound during voice communications of a mobile telephone when the lighting devices (backlights) for a liquid crystal display device and keypad portion of a mobile telephone are lit, such as that night.”). A person of ordinary skill in the art at the time of the alleged invention would be motivated to modify Seo to use “a microprocessor adapted to” as disclosed in Fukihara 598 for a number of different reasons, including that it would support Seo’s ability to conserve battery power in mobile stations, and doing so would be within the knowledge and ability of a person of ordinary skill in the art at the time of the alleged invention. The combination would constitute, at least, combining prior art elements according to known methods to yield predictable results, a simple substitution of one known element for another to obtain predictable results, the use of a known technique to improve similar devices in the same way, the application of a known technique to a known device ready for improvement to yield a predictable result, and obvious to try.

To the extent Seo is deemed to not expressly or inherently disclose a “a microprocessor adapted to,” it would be obvious to combine the disclosure of Seo with those of Numazawa as described in the Numazawa claim chart, which is incorporated herein in its entirety by reference. Seo and Numazawa are both directed to conserving battery power in mobile stations generally and more particularly at conserving battery power in mobile stations by using sensors to detect when the user of the mobile station is in a call and unlikely to be looking at the display (as when, for example, the proximity sensor detects the user’s ear by the mobile station) and to power off the display of mobile stations at such times. Seo at 1:36-42 (“It is hence a primary object of the invention to present a novel cordless telephone capable of, by solving the above mentioned technical problems, stopping the display action by the display device while the handset is in service so as to minimize the wasteful consumption of the electric power supplied from the battery or the like.”), 3:64-4:5 (When the receiver 6 is not in contact with the user’s ear, the light emitting element 3 lights up at step n8. In this state, when the user touches the receiver 6 of the handset by the ear, it is detected by the piezoelectric element 7, and the detection signal is sent out to the control circuit 11. The control circuit 11, on the basis of this detection signal, sends out a stop signal to

the driver 12. Thus, driving of the driver 12 is stopped, and the light emitting element 3 is extinguished at step n7.”); Numazawa at ¶ Abstract (“To achieve reduced power consumption through stopping operation of unnecessary functions during use of a wireless terminal. A CPU 2 identifies start of a call state through a signal from a signal processing portion 3 for controlling communication with a base station, and identifies, through an output signal from detecting means 6, whether or not a user ear is in contact with a terminal. Upon identification of contact of the ear to the terminal, controlling means 8 are caused to stop the supply of electric power, from a power supply 7, to displaying means 9 for providing information to a user, and lighting means 10, such as a black light.”), ¶ 0005-0007 (“In the present invention, control is such that, upon determination that the wireless terminal is in a call, operation of functions believe be unnecessary, due to the user of the terminal being in a call, is stopped, and upon termination of the call, operation of the stopped functions is restarted. Additionally, because it is envisioned that there will also be cases where, even during a call, the face of the user may be separated from the receiver of the terminal, control is performed so as to enable restarting of the operations of the functions that had been stopped as unnecessary, through detecting whether or not the user of the terminal has the receiver in contact with an ear. The achievement of reduced power consumption through stopping operation of functions that become unnecessary in use of the terminal, as described above, can be anticipated to have the effect of extending the life of the power supply, such as a battery.”). A person of ordinary skill in the art at the time of the alleged invention would be motivated to modify Seo to use “a microprocessor adapted to” as disclosed in Numazawa for a number of different reasons, including that it would support Seo’s ability to conserve battery power in mobile stations, and doing so would be within the knowledge and ability of a person of ordinary skill in the art at the time of the alleged invention. The combination would constitute, at least, combining prior art elements according to known methods to yield predictable results, a simple substitution of one known element for another to obtain predictable results, the use of a known technique to improve similar devices in the same way, the application of a known technique to a known device ready for improvement to yield a predictable result, and obvious to try.

To the extent Seo is deemed to not expressly or inherently disclose a “mobile station,” it would be obvious to combine the disclosure of Seo with those of Miyashita as described in the Miyashita claim chart, which is incorporated herein in its entirety by reference. Seo and Miyashita are both directed to conserving battery power in mobile stations generally and more particularly at conserving battery power in mobile stations by using sensors to detect when the user of the mobile station is in a call and unlikely to be looking at the display (as when, for example, the proximity sensor detects the user’s ear by the mobile station or a sensor detects that the mobile station is in a vertical orientation) and to power off the display of mobile stations at such times. Seo at 1:36-42 (“It is hence a primary object of the invention to present a novel cordless telephone capable of, by solving the above mentioned technical problems, stopping the display action by the display device while the handset is in service so as to minimize the wasteful consumption of the electric power supplied from the battery or the like.”), 3:64-4:5 (“When the receiver 6 is not in contact with the user’s ear, the light emitting element 3 lights up at step n8. In this state, when the user touches the receiver 6 of the handset by the ear, it is detected by the piezoelectric element 7, and the detection signal is sent out to the control circuit 11. The control circuit 11, on the basis of this detection signal, sends out a stop signal to the driver 12. Thus, driving of the driver 12 is stopped, and the light emitting element 3 is extinguished at step n7.”); Miyashita at 1:58-63 (“The present invention is directed to solving the problem set forth above. It is therefore an object of the present invention to provide a portable telephone set which can shut off the power supply for a display portion while a content of the display will not be seen during speaking, and thus can reduce power consumption.”), 2:6-11 (“In the preferred construction the detector is a gyro. The control apparatus may shut off the power supply for the display when the detector detects the main body at a substantially vertical position. On the other hand, the control may initiate power supply for the display when the detector detects the main body at a substantially horizontal position.”). A person of ordinary skill in the art at the time of the alleged invention would be motivated to modify Seo to use “a microprocessor adapted to” as disclosed in Miyashita for a number of different reasons, including that it would support Seo’s ability to conserve battery power in mobile stations, and doing so would be within the knowledge and ability of a person of ordinary skill in the art at the time of the alleged invention. The combination would constitute, at least, combining prior art elements according to known methods to yield predictable results, a simple substitution of one

	<p>known element for another to obtain predictable results, the use of a known technique to improve similar devices in the same way, the application of a known technique to a known device ready for improvement to yield a predictable result, and obvious to try.</p>
<p>[1d] (a) determine whether a telephone call is active;</p>	<p>Seo discloses the microprocessor adapted to determine whether a telephone call is active.</p> <p>For example: “CORDLESS TELEPHONE.” Seo at Title.</p> <p>“A cordless telephone includes a base unit connected to a telephone line so as to communicate by radio waves for talking and a handset. The handset includes a speaker, a microphone, and a transmitting and receiving circuit for communicating with the base unit by radio waves, transforming the signals from the caller into acoustic sound by the speaker, and sending the output from the microphone to the caller. The handset further includes a battery for providing the transmitting and receiving circuit with electric power. Still further, the handset includes a device for display to indicate the in-service state, a device for detecting the contact of the speaker area with a part of the body, a device for detecting talking to detect the in-service state, and a device for controlling to stop the display action of the display device when the speaker area is in contact with a part of the body and is in service this stopping of the display device occurs response to the output from the contact detecting device and the talk detecting device. The control device further affects the display action by the display device while the speaker area is not in contact with the body during service. The handset, in this device, is electrically powered by a battery.” Seo at Abstract.</p> <p>“To achieve the above object, the cordless telephone of the invention comprises:</p> <p>(a) a base unit connected to a telephone line so as to communicate by radio waves for talking, and</p> <p>(b) a handset comprising:</p>

<p>(b1) a speaker,</p> <p>(b2) a microphone,</p> <p>(b3) a transmitting and receiving circuit for communicating with the base unit by radio waves, transforming the signals from the caller into acoustic sound in the speaker, and sending the output from the microphone to the caller, and</p> <p>(b4) a battery for providing the transmitting and receiving circuit with electric power, wherein</p> <p>(c) the handset further comprises:</p> <p>(c1) a device for display to indicate the in-service state,</p> <p>...</p> <p>(c3) a device for detecting the talk to detect the in-service state, and</p> <p>(c4) a device for controlling to stop the display action of the display a device when the speaker area is in contact with a part of the body and is in service, in response to the output from the contact detecting device and talk detecting device, and to effect the display action by the display device while the speaker area is not in contact with the body during service,” Seo at 1:43-64.</p> <p>“The invention also relates to a cordless telephone having a base unit connected to a telephone line and a handset connected to the base unit through radio communication and equipped with a device for display so as to indicate the in-service state by the handset by the display device, which includes:...” Seo at 2:16-21.</p> <p>“FIG. 1 is a perspective view showing the entire structure of a cordless telephone 21 according to an embodiment of the invention. The cordless telephone 21 is connected to a telephone line 22, and include a handset 25 and a base unit 23 for radio communication therewith, the base unit 23 having an antenna 24 for radio communication with the handset 25. The handset 25 includes key switches 2 such as</p>	
--	--

“FIG. 2 is a block diagram showing a schematic electrical construction of the cordless telephone 21.

In this diagram, a key signal by the operation of the key switch 2 is given to a control circuit 11 which is a device for controlling the members in the handset 25. It is also sent out from the antenna 8 through a transmitting and receiving circuit 13, and is received through the antenna 24 of the base unit 23. It is then sent out to the telephone at the destination through the telephone line 22. Further, by the key signal from the key switch 2, the control circuit 11 sends out a drive signal to a driver 12 for lighting up the light emitting element 3. Thus, the driver 12 is driven to light up the light emitting element 3.... At the same time, the control circuit 11 sends out a control signal to the transmitting and receiving circuit 13. The transmitting and receiving circuit 13 amplifies and modulates the transmission signal received from a microphone 14 built in the transmitter 5. It then sends out a signal from the antenna 8, and demodulates and amplifies the reception signal sent from the base unit 23 through the telephone line 22 which is a communication circuit. Finally, it sends out a signal to a speaker 15 built in the receiver 6. Thus, an acoustic signal is delivered from the speaker 15. Such a handset 25 is electrically powered by a built-in battery 28.” See at 3:23-52.

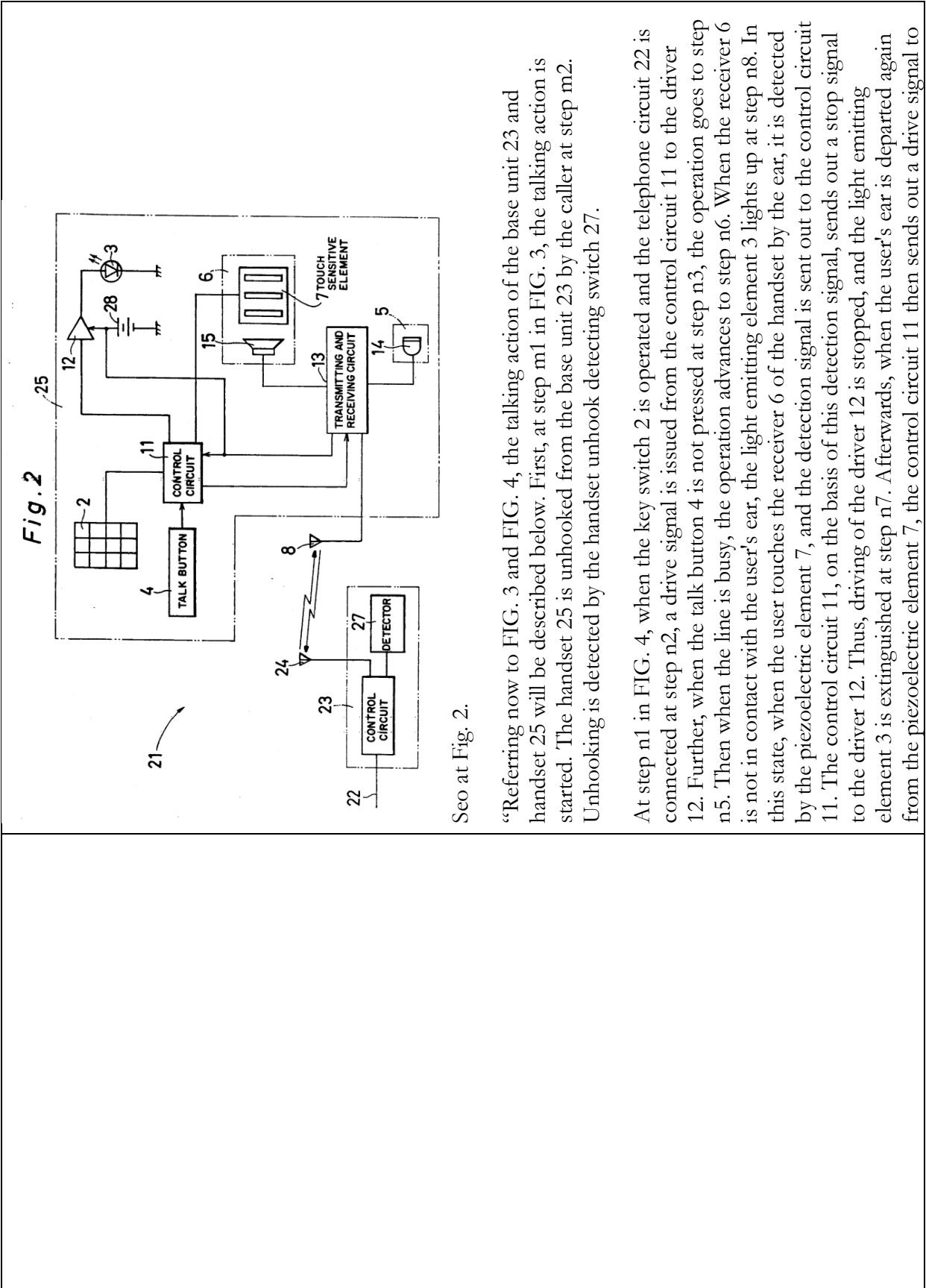

Fig. 2

See at Fig. 2.

“Referring now to FIG. 3 and FIG. 4, the talking action of the base unit 23 and handset 25 will be described below. First, at step m1 in FIG. 3, the talking action is started. The handset 25 is unhooked from the base unit 23 by the caller at step m2. Unhooking is detected by the handset unhook detecting switch 27.

At step n1 in FIG. 4, when the key switch 2 is operated and the telephone circuit 22 is connected at step n2, a drive signal is issued from the control circuit 11 to the driver 12. Further, when the talk button 4 is not pressed at step n3, the operation goes to step n5. Then when the line is busy, the operation advances to step n6. When the receiver 6 is not in contact with the user's ear, the light emitting element 3 lights up at step n8. In this state, when the user touches the receiver 6 of the handset by the ear, it is detected by the piezoelectric element 7, and the detection signal is sent out to the control circuit 11. The control circuit 11, on the basis of this detection signal, sends out a stop signal to the driver 12. Thus, driving of the driver 12 is stopped, and the light emitting element 3 is extinguished at step n7. Afterwards, when the user's ear is departed again from the piezoelectric element 7, the control circuit 11 then sends out a drive signal to

the driver 12 to drive the driver 12. This thereby lights the light emitting element 3 again. Afterwards, by pressing the hang-up button 4 at step n3, a communication circuit cut-off signal is sent out from the handset 25 to the base unit 23 at step n4. Thus the base unit 23 receives the communication circuit signal at step m4 in FIG. 3. Then the connection with the telephone line 22 is cut off at step m5, so that the light emitting element 3 of the handset 25 goes out.” Seo at 3:53-4:16.

Fig. 3

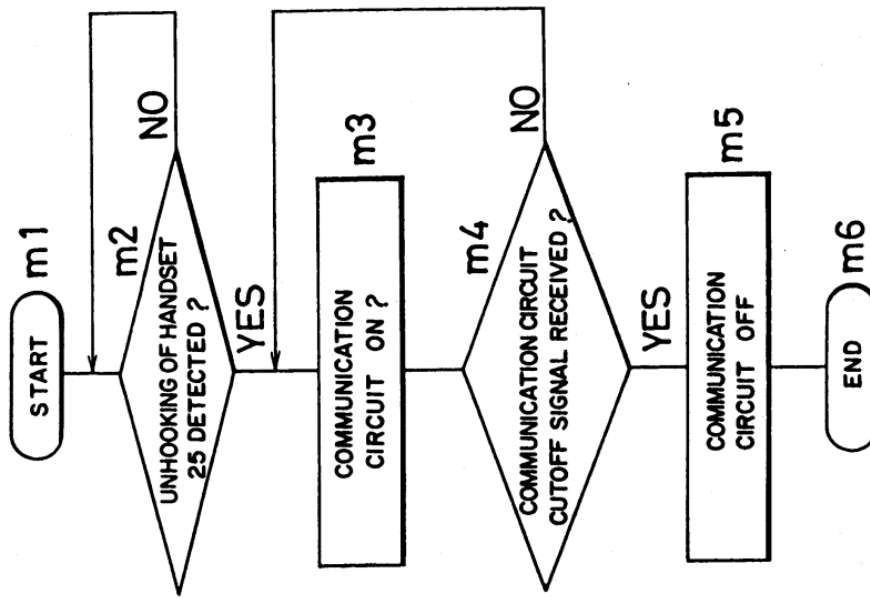

See at Fig. 3.

Fig. 4

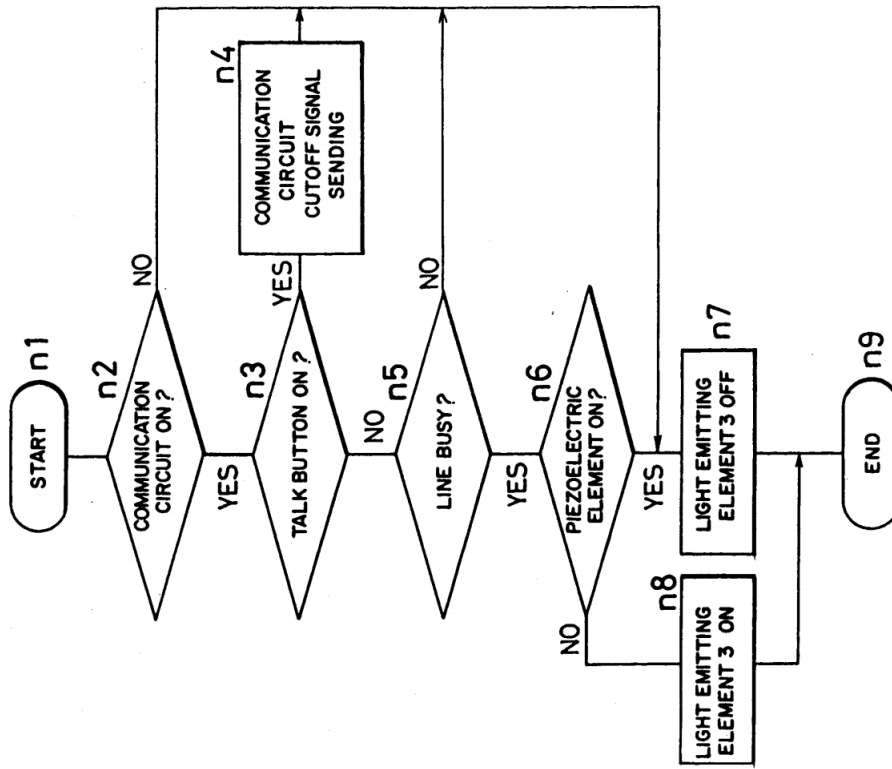

See at Fig. 4.

"1. A cordless telephone apparatus including a base unit connected to a telephone line for communication, and a handset, operatively connected to the base unit by radio

waves, including a speaker, a microphone, a transmitting and receiving circuit for communicating with the base unit by radio waves, transforming the signals from a caller into acoustic sound by the speaker, and second the output from the microphone to the caller, and a battery for providing the transmitting and receiving circuit with electric power, the handset further comprising:

display means for indicating an in-service state of the cordless telephone activated for communication;

contact detecting means for detecting contact of a user with an area proximate to the speaker;

activation detecting means for detecting activation of the cordless telephone for communications to detect the in-service state; and

control means operatively connected to the display means, the contact detecting means and the activation detecting means, for controlling the display means to stop indicating an in-service state when an area proximate to the speaker is detected to be in contact with a user and an in service state is detected, in response to the contact detecting means and activation detecting means, and for controlling the display means to indicate an in-service state when an area proximate to the speaker is not detected to be in contact with a user and an in service state is detected; and

the handset battery means for electrically powering the handset.” Seo at claim 1.

“4. The cordless telephone apparatus of claim 1, wherein the handset further comprises dial means for dial input, and the control means generates a dial signal in response to activation of the dial input means to initiate or call via the base unit.” Seo at claim 4.

“6. A cordless telephone apparatus including a base unit connected to a telephone line and a handset operatively connected to the base unit via radio communication and equipped with a display device for indicating an in-service state of the handset, the handset comprising:

contact detecting means for detecting contact when a part of the body of the user contacts with an area proximate to a speaker of the handset, and

stopping means for stopping the display device from indicating the in-service state when a part of the body of the user is detected to be in contact with an area proximate to the speaker of the handset, in response to the contact detecting means.

7. A handset of a cordless telephone including a base unit and the handset including a speaker and a transmitter for communicating, by radio communications, with the base unit, the handset further comprising:

display means for displaying indication of the cordless telephone being in-service;

detecting means for emitting a signal upon detecting contact of a user to an area of the handset in close proximity to the speaker; and

control means, operatively connected to said display means and said detecting means, for controlling said display means to display indication of the cordless telephone being in-service upon not receiving an output signal from said detecting means when the cordless telephone is in service and for controlling said display means to stop displaying indication of the cordless telephone being in-service upon receiving an output signal from the detecting means when the cordless telephone is in service.

8. The handset of claim 7 further comprising:

in-service detection means, operatively connected to said control means, for outputting a signal to said control means, upon detecting that the cordless telephone is in-service.”
See at claims 6-8.

“14. The handset of claim 7, further comprising:

end of service means, operatively connected to said control means, for outputting a signal to the control means to indicate that the cordless telephone is not in-service, and wherein said control means, upon receipt of said output signal from said end of service

means, controls said display means to stop displaying indication of the cordless telephone being in service.

15. The handset of claim 7, further comprising:

battery means, operatively connected to said display means for providing power to enable said display means to display in-service indication.

16. A method of conserving power of a battery in a cordless telephone, including a handset with a battery, a speaker and a receiver and further including a base unit, which indicates to a user when the cordless telephone is in-service, comprising the steps of:

(a) displaying indication, on the handset, of the cordless telephone in-service;

(b) supplying power from the battery during said step (a) of displaying;

(c) detecting contact of a user to an area of the handset in close proximity to the speaker;

(d) inhibiting said step (a) of displaying by stopping said step (b) of supplying power upon detecting contact in step (c) to thus conserve battery power while said telephone is in-service

17. The method of claim 16, further comprising the step of:

(e) terminating said step (a) of displaying upon said telephone not being in-service. Seo at Claim 17.” Seo at claims 14-17.

To the extent Seo is deemed to not expressly disclose the microprocessor adapted to “determine whether a telephone call is active,” Seo inherently discloses this limitation. Seo specifies that the step of detecting a signal from the proximity sensor (piezoelectric element 7) is reached only after it is determined that the “line is busy”. *See* Seo at 3:62-4:1 (“Further, when the talk button 4 is not pressed at step n3, the operation goes to

step n5. Then when the line is busy, the operation advances to step n6. When the receiver 6 is not in contact with the user's ear, the light emitting element 3 lights up at step n8. In this state, when the user touches the receiver 6 of the handset by the ear, it is detected by the piezoelectric element 7, and the detection signal is sent out to the control circuit 11.”), Fig. 4. A person of ordinary skill in the art at the time of the alleged invention would therefore understand that, in order for the mobile station to determine whether the “line is busy” it must necessarily “determine[s] whether a telephone call is active.” Further as noted above for element [1c] and incorporated by reference here, Seo discloses or renders obvious the use of a microprocessor. Therefore, a person of ordinary skill in the art at the time of the alleged invention would understand that necessarily the microprocessor of Seo would “determine whether a telephone call is active.”

To the extent Seo is deemed to not expressly disclose the microprocessor adapted to “determine whether a telephone call is active,” Seo renders this limitation obvious to one of ordinary skill in the art at the time of the alleged invention. Seo specifies that the step of detecting a signal from the proximity sensor (piezoelectric element 7) is reached only after it is determined that the “line is busy”. *See* Seo at 3:62-4:1 (“Further, when the talk button 4 is not pressed at step n3, the operation goes to step n5. Then when the line is busy, the operation advances to step n6. When the receiver 6 is not in contact with the user's ear, the light emitting element 3 lights up at step n8. In this state, when the user touches the receiver 6 of the handset by the ear, it is detected by the piezoelectric element 7, and the detection signal is sent out to the control circuit 11.”), Fig. 4. Further as noted above for element [1c] and incorporated by reference here, Seo discloses or renders obvious the use of a microprocessor. A person of ordinary skill in the art at the time of the alleged invention would find it obvious to implement the microprocessor of Seo to determine whether the “line is busy.” Doing so would be a design choice driven by a number of different reasons, including that it would support Seo's ability to conserve battery power in mobile stations, and doing so would be within the knowledge and ability of a person of ordinary skill in the art at the

time of the alleged invention. Doing so would also constitute, at least, combining prior art elements according to known methods to yield predictable results, a simple substitution of one known element for another to obtain predictable results, the use of a known technique to improve similar devices in the same way, the application of a known technique to a known device ready for improvement to yield a predictable result, and obvious to try.

To the extent Seo is deemed to not expressly or inherently disclose microprocessor adapted to “determine whether a telephone call is active,” it would be obvious to combine the disclosure of Seo with those of Fukihara 598 as described in the Fukihara 598 claim chart, which is incorporated herein in its entirety by reference. Seo and Fukihara 598 are both directed to conserving battery power in mobile stations generally and more particularly at conserving battery power in mobile stations by using sensors to detect when the user of the mobile station is in a call and unlikely to be looking at the display (as when, for example, the proximity sensor detects the user’s ear by the mobile station) and to power off the display of mobile stations at such times. Seo at 1:36-42 (“It is hence a primary object of the invention to present a novel cordless telephone capable of, by solving the above mentioned technical problems, stopping the display action by the display device while the handset is in service so as to minimize the wasteful consumption of the electric power supplied from the battery or the like.”), 3:64-4:5 (“When the receiver 6 is not in contact with the user’s ear, the light emitting element 3 lights up at step n8. In this state, when the user touches the receiver 6 of the handset by the ear, it is detected by the piezoelectric element 7, and the detection signal is sent out to the control circuit 11. The control circuit 11, on the basis of this detection signal, sends out a stop signal to the driver 12. Thus, driving of the driver 12 is stopped, and the light emitting element 3 is extinguished at step n7.”); Fukiharu 598 at ¶ 0018 (“The present invention, through the use of a structure as described above, enables a reduction in the consumption of battery power, through enabling the lighting devices to be turned OFF when the ear is caused to contact the receiver portion in order to hear the receiver sound during voice communications of a mobile telephone when the lighting devices (backlights) for a liquid crystal display device and keypad portion of a mobile telephone are lit, such as that night.”). A person of ordinary skill in the art at

the time of the alleged invention would be motivated to modify Seo to implement microprocessor adapted to “determine whether a telephone call is active,” as disclosed in Fukihara 598 for a number of different reasons, including that it would support Seo’s ability to conserve battery power in mobile stations, and doing so would be within the knowledge and ability of a person of ordinary skill in the art at the time of the alleged invention. The combination would constitute, at least, combining prior art elements according to known methods to yield predictable results, a simple substitution of one known element for another to obtain predictable results, the use of a known technique to improve similar devices in the same way, the application of a known technique to a known device ready for improvement to yield a predictable result, and obvious to try.

To the extent Seo is deemed to not expressly or inherently disclose the microprocessor adapted to “determine whether a telephone call is active,” it would be obvious to combine the disclosure of Seo with those of Numazawa as described in the Numazawa claim chart, which is incorporated herein in its entirety by reference. Seo and Numazawa are both directed to conserving battery power in mobile stations generally and more particularly at conserving battery power in mobile stations by using sensors to detect when the user of the mobile station is in a call and unlikely to be looking at the display (as when, for example, the proximity sensor detects the user’s ear by the mobile station) and to power off the display of mobile stations at such times. Seo at 1:36-42 (“It is hence a primary object of the invention to present a novel cordless telephone capable of, by solving the above mentioned technical problems, stopping the display action by the display device while the handset is in service so as to minimize the wasteful consumption of the electric power supplied from the battery or the like.”), 3:64-4:5 (“When the receiver 6 is not in contact with the user’s ear, the light emitting element 3 lights up at step n8. In this state, when the user touches the receiver 6 of the handset by the ear, it is detected by the piezoelectric element 7, and the detection signal is sent out to the control circuit 11. The control circuit 11, on the basis of this detection signal, sends out a stop signal to the driver 12. Thus, driving of the driver 12 is stopped, and the light emitting element 3 is extinguished at step n7.”); Numazawa at ¶ Abstract (“To achieve reduced power consumption through stopping operation of unnecessary functions during use of a wireless terminal. A CPU 2 identifies start of a call state

through a signal from a signal processing portion 3 for controlling communication with a base station, and identifies, through an output signal from detecting means 6, whether or not a user ear is in contact with a terminal. Upon identification of contact of the ear to the terminal, controlling means 8 are caused to stop the supply of electric power, from a power supply 7, to displaying means 9 for providing information to a user, and lighting means 10, such as a black light.”, ¶ 0005-0007 (“In the present invention, control is such that, upon determination that the wireless terminal is in a call, operation of functions believe be unnecessary, due to the user of the terminal being in a call, is stopped, and upon termination of the call, operation of the stopped functions is restarted. Additionally, because it is envisioned that there will also be cases where, even during a call, the face of the user may be separated from the receiver of the terminal, control is performed so as to enable restarting of the operations of the functions that had been stopped as unnecessary, through detecting whether or not the user of the terminal has the receiver in contact with an ear. The achievement of reduced power consumption through stopping operation of functions that become unnecessary in use of the terminal, as described above, can be anticipated to have the effect of extending the life of the power supply, such as a battery.”). A person of ordinary skill in the art at the time of the alleged invention would be motivated to modify Seo to implement the microprocessor adapted to “determine whether a telephone call is active,” as disclosed in Numazawa for a number of different reasons, including that it would support Seo’s ability to conserve battery power in mobile stations, and doing so would be within the knowledge and ability of a person of ordinary skill in the art at the time of the alleged invention. The combination would constitute, at least, combining prior art elements according to known methods to yield predictable results, a simple substitution of one known element for another to obtain predictable results, the use of a known technique to improve similar devices in the same way, the application of a known technique to a known device ready for improvement to yield a predictable result, and obvious to try.

To the extent Seo is deemed to not expressly or inherently disclose that “determine whether a telephone call is active,” it would be obvious to combine the disclosure of Seo with those of Miyashita as described in the Miyashita claim chart, which is incorporated herein in its entirety by reference. Seo and Miyashita are both directed to

conserving battery power in mobile stations generally and more particularly at conserving battery power in mobile stations by using sensors to detect when the user of the mobile station is in a call and unlikely to be looking at the display (as when, for example, the proximity sensor detects the user's ear by the mobile station or a sensor detects that the mobile station is in a vertical orientation) and to power off the display of mobile stations at such times. Seo at 1:36-42 ("It is hence a primary object of the invention to present a novel cordless telephone capable of, by solving the above mentioned technical problems, stopping the display action by the display device while the handset is in service so as to minimize the wasteful consumption of the electric power supplied from the battery or the like."), 3:64-4:5 (When the receiver 6 is not in contact with the user's ear, the light emitting element 3 lights up at step n8. In this state, when the user touches the receiver 6 of the handset by the ear, it is detected by the piezoelectric element 7, and the detection signal is sent out to the control circuit 11. The control circuit 11, on the basis of this detection signal, sends out a stop signal to the driver 12. Thus, driving of the driver 12 is stopped, and the light emitting element 3 is extinguished at step n7."); Miyashita at 1:58-63 ("The present invention is directed to solving the problem set forth above. It is therefore an object of the present invention to provide a portable telephone set which can shut off the power supply for a display portion while a content of the display will not be seen during speaking, and thus can reduce power consumption."), 2:6-11 ("In the preferred construction the detector is a gyro. The control apparatus may shut off the power supply for the display when the detector detects the main body at a substantially vertical position. On the other hand, the control may initiate power supply for the display when the detector detects the main body at a substantially horizontal position."). A person of ordinary skill in the art at the time of the alleged invention would be motivated to modify Seo to implement the microprocessor adapted to "determine whether a telephone call is active," as disclosed in Miyashita for a number of different reasons, including that it would support Seo's ability to conserve battery power in mobile stations, and doing so would be within the knowledge and ability of a person of ordinary skill in the art at the time of the alleged invention. The combination would constitute, at least, combining prior art elements according to known methods to yield predictable results, a simple substitution of one known element for another to obtain predictable results, the use of a known technique to improve similar devices in the same way, the application of a known

<p>[1e] (b) receive the signal from the proximity sensor; and</p>	<p>technique to a known device ready for improvement to yield a predictable result, and obvious to try.</p>
<p>Seo discloses the microprocessor adapted to receive the signal from the proximity sensor.</p> <p>For example: <i>see</i> discussion of claim element [1b], <i>supra</i>, which is incorporated herein by reference.</p> <p>“Still further, the headset includes a device for display to indicate the in-service state, a device for detecting the contact of the speaker area with a part of the body, a device for detecting talking to detect the in-service state, and a device for controlling to stop the display action of the display device when the speaker area is in contact with a part of the body and is in service this stopping of the display device occurs response to the output from the contact detecting device and the talk detecting device. The control device further affects the display action by the display device while the speaker area is not in contact with the body during service. The headset, in this device, is electrically powered by a battery.” Seo at Abstract.</p> <p>“To achieve the above object, the cordless telephone of the invention comprises:</p> <p>(a) a base unit connected to a telephone line so as to communicate by radio waves for talking, and</p> <p>(b) a headset comprising:</p> <p>(b1) a speaker,</p> <p>(b2) a microphone,</p>	<p>Seo discloses the microprocessor adapted to receive the signal from the proximity sensor.</p> <p>For example: <i>see</i> discussion of claim element [1b], <i>supra</i>, which is incorporated herein by reference.</p> <p>“Still further, the headset includes a device for display to indicate the in-service state, a device for detecting the contact of the speaker area with a part of the body, a device for detecting talking to detect the in-service state, and a device for controlling to stop the display action of the display device when the speaker area is in contact with a part of the body and is in service this stopping of the display device occurs response to the output from the contact detecting device and the talk detecting device. The control device further affects the display action by the display device while the speaker area is not in contact with the body during service. The headset, in this device, is electrically powered by a battery.” Seo at Abstract.</p> <p>“To achieve the above object, the cordless telephone of the invention comprises:</p> <p>(a) a base unit connected to a telephone line so as to communicate by radio waves for talking, and</p> <p>(b) a headset comprising:</p> <p>(b1) a speaker,</p> <p>(b2) a microphone,</p>

(b3) a transmitting and receiving circuit for communicating with the base unit by radio waves, transforming the signals from the caller into acoustic sound in the speaker, and sending the output from the microphone to the caller, and

(b4) a battery for providing the transmitting and receiving circuit with electric power, wherein

(c) the handset further comprises:

(c1) a device for display to indicate the in-service state,

(c2) a device for detecting the contact of the speaker area with a part of the body,

(c3) a device for detecting the talk to detect the in-service state, and

(c4) a device for controlling to stop the display action of the display a device when the speaker area is in contact with a part of the body and is in service, in response to the output from the contact detecting device and talk detecting device, and to effect the display action by the display device while the speaker area is not in contact with the body during service, and

(c5) the handset is electrically powered by the battery.” Seo at 1:43-2:4.

“FIG. 1 is a perspective view showing the entire structure of a cordless telephone 21 according to an embodiment of the invention. The cordless telephone 21 is connected to a telephone line 22, and include a handset 25 and a base unit 23 for radio communication therewith, the base unit 23 having an antenna 24 for radio communication with the handset 25. The handset 25 includes key switches 2 such as numeric keys as a dial input device provided inside the grip of a handset unit 1; a light emitting element 3 as a display device composed of a light emitting diode (LED) or the like disposed in the vicinity of the key switches 2 inside the grip; a disconnect or hang-up button 4 as the talk completion device for changing over between line capturing state and talk waiting state; a transmitter 5 with a microphone 14 built in and located near the mouth of the user; a receiver 6 containing a piezoelectric element 7 known as touch sensor or the like as the contact detecting device when contacting with the ear,

that is, a part of the body of the user contacted while talking; an antenna 8 for communicating with the base unit 23; and a battery 28." Seo at 3:1-22."

Fig 1

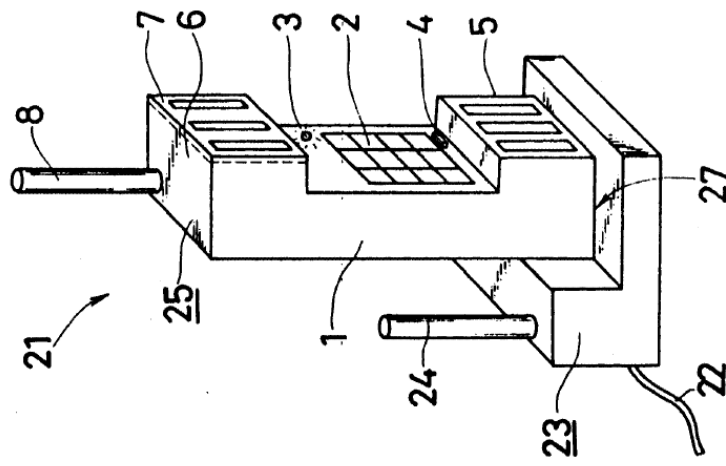

Seo at Fig. 1.

"FIG. 2 is a block diagram showing a schematic electrical construction of the cordless telephone 21.

In this diagram, a key signal by the operation of the key switch 2 is given to a control circuit 11 which is a device for controlling the members in the handset 25. It is also sent out from the antenna 8 through a transmitting and receiving circuit 13, and is received through the antenna 24 of the base unit 23. It is then sent out to the telephone at the destination through the telephone line 22. Further, by the key signal from the key switch 2, the control circuit 11 sends out a drive signal to a driver 12 for lighting up the light emitting element 3. Thus, the driver 12 is driven to light up the light emitting element 3. In the meantime, a signal from the piezoelectric element 7 is applied to the control circuit 11, and a stop signal is sent out to the driver 12 from this piezoelectric element 7. Thus, driving of the driver 12 is stopped to extinguish the light emitting element 3. At the same time, the control circuit 11 sends out a control signal to the transmitting and receiving circuit 13..” See at 3:23-52.

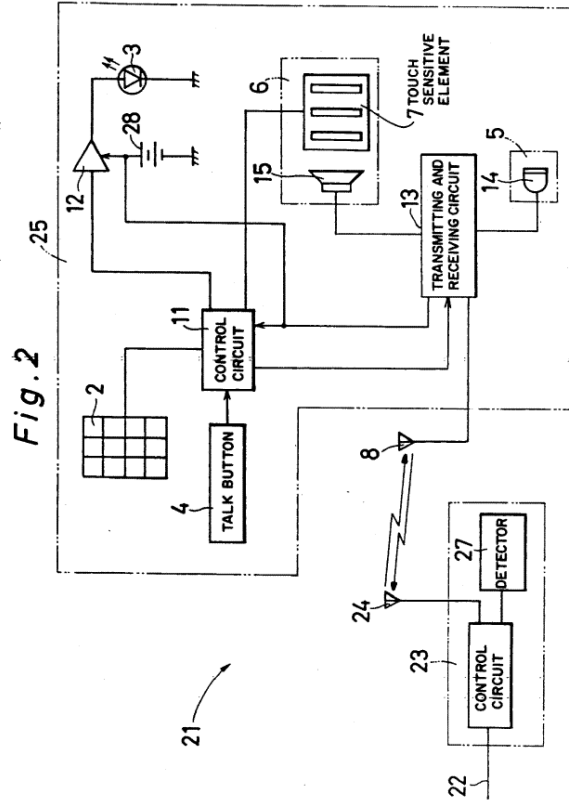

See at Fig. 2.

“At step n1 in FIG. 4, when the key switch 2 is operated and the telephone circuit 22 is connected at step n2, a drive signal is issued from the control circuit 11 to the driver 12. Further, when the talk button 4 is not pressed at step n3, the operation goes to step

n5. Then when the line is busy, the operation advances to step n6. When the receiver 6 is not in contact with the user's ear, the light emitting element 3 lights up at step n8. In this state, when the user touches the receiver 6 of the handset by the ear, it is detected by the piezoelectric element 7, and the detection signal is sent out to the control circuit 11. The control circuit 11, on the basis of this detection signal, sends out a stop signal to the driver 12. Thus, driving of the driver 12 is stopped, and the light emitting element 3 is extinguished at step n7. Afterwards, when the user's ear is departed again from the piezoelectric element 7, the control circuit 11 then sends out a drive signal to the driver 12 to drive the driver 12. This thereby lights the light emitting element 3 again. Afterwards, by pressing the hang-up button 4 at step n3, a communication circuit cut-off signal is sent out from the handset 25 to the base unit 23 at step n4. Thus the base unit 23 receives the communication circuit signal at step m4 in FIG. 3. Then the connection with the telephone line 22 is cut off at step m5, so that the light emitting element 3 of the handset 25 goes out." See at 3:59-4:16.

Fig. 3

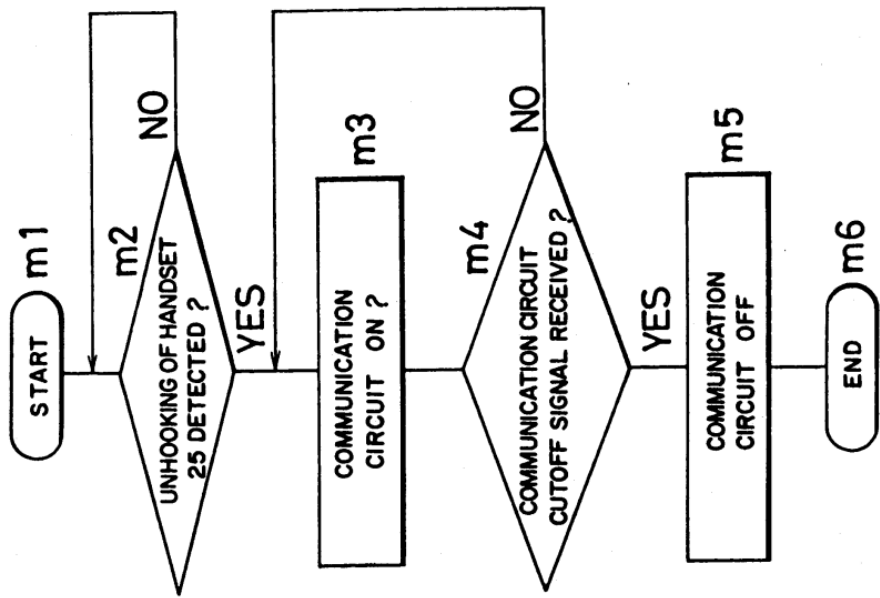

See at Fig. 3.

Fig. 4

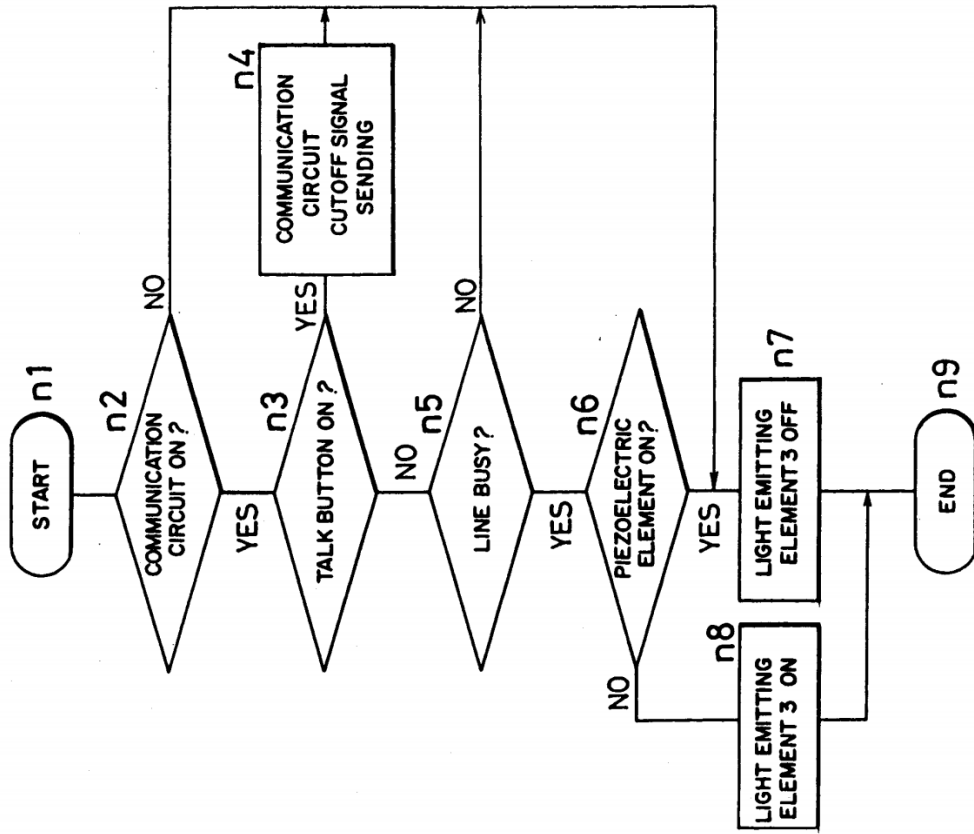

See at Fig. 4.

“1. A cordless telephone apparatus including a base unit connected to a telephone line for communication, and a handset, operatively connected to the base unit by radio waves, including a speaker, a microphone, a transmitting and receiving circuit for communicating with the base unit by radio waves, transforming the signals from a caller into acoustic sound by the speaker, and second the output from the microphone to the caller, and a battery for providing the transmitting and receiving circuit with electric power, the handset further comprising:

display means for indicating an in-service state of the cordless telephone activated for communication;

contact detecting means for detecting contact of a user with an area proximate to the speaker;

activation detecting means for detecting activation of the cordless telephone for communications to detect the in-service state; and

control means operatively connected to the display means, the contact detecting means and the activation detecting means, for controlling the display means to stop indicating an in-service state when an area proximate to the speaker is detected to be in contact with a user and an in service state is detected, in response to the contact detecting means and activation detecting means, and for controlling the display means to indicate an in-service state when an area proximate to the speaker is not detected to be in contact with a user and an in service state is detected; and

the handset battery means for electrically powering the handset.” Seo at claim 1.

“5. The cordless telephone apparatus of claim 1, wherein the contact detecting means includes a penetration hole in an area proximate to the speaker, the speaker being disposed behind the contact detecting means.” Seo at claim 5.

“6. A cordless telephone apparatus including a base unit connected to a telephone line and a handset operatively connected to the base unit via radio communication and

equipped with a display device for indicating an in-service state of the handset, the handset comprising:

contact detecting means for detecting contact when a part of the body of the user contacts with an area proximate to a speaker of the handset, and

stopping means for stopping the display device from indicating the in-service state when a part of the body of the user is detected to be in contact with an area proximate to the speaker of the handset, in response to the contact detecting means.” Seo at claim 6.

“7. A handset of a cordless telephone including a base unit and the handset including a speaker and a transmitter for communicating, by radio communications, with the base unit, the handset further comprising:

display means for displaying indication of the cordless telephone being in-service;

detecting means for emitting a signal upon detecting contact of a user to an area of the handset in close proximity to the speaker; and

control means, operatively connected to said display means and said detecting means, for controlling said display means to display indication of the cordless telephone being in-service upon not receiving an output signal from said detecting means when the cordless telephone is in service and for controlling said display means to stop displaying indication of the cordless telephone being in-service upon receiving an output signal from the detecting means when the cordless telephone is in service.” Seo at claim 7.

“9. The handset of claim 7, wherein the detecting means is a piezoelectric element and the piezoelectric element is disposed in close proximity to the speaker.” Seo at claim 9.

“12. The handset of claim 11, wherein the detecting means is a piezoelectric element disposed in close proximity to the speaker.

	<p>13. The handset of claim 12, wherein the piezoelectric element detects contact of the user's ear to the handset, proximate to the speaker, and outputs a signal.” Seo at claims 12-13.</p> <p>“16. A method of conserving power of a battery in a cordless telephone, including a handset with a battery, a speaker and a receiver and further including a base unit, which indicates to a user when the cordless telephone is in-service, comprising the steps of:</p> <ul style="list-style-type: none"> (a) displaying indication, on the handset, of the cordless telephone in-service; (b) supplying power from the battery during said step (a) of displaying; (c) detecting contact of a user to an area of the handset in close proximity to the speaker; (d) inhibiting said step (a) of displaying by stopping said step (b) of supplying power upon detecting contact in step (c) to thus conserve battery power while said telephone is in-service.” Seo at claim 17. <p>“18. The method of claim 16, wherein said step (c) of detecting contact detects contact of a user's ear to an area of the handset in close proximity to the speaker.” Seo at claim 18.</p>
<p>[1f] (c) reduce power to the display if (i) the microprocessor determines that a telephone call is active and (ii) the signal indicates the proximity of the external object; wherein:</p>	<p>Seo discloses the microprocessor adapted to reduce power to the display if (i) the microprocessor determines that a telephone call is active and (ii) the signal indicates the proximity of the external object.</p> <p>For example: <i>see</i> discussions of claim elements [1b], [1d], [1e], <i>supra</i>, which are incorporated herein by reference.</p> <p>“Still further, the handset includes a device for display to indicate the in-service state, a device for detecting the contact of the speaker area with a part of the body, a device for detecting talking to detect the in-service state, and a device for controlling to stop the</p>

display action of the display device when the speaker area is in contact with a part of the body and is in service this stopping of the display device occurs response to the output from the contact detecting device and the talk detecting device. The control device further affects the display action by the display device while the speaker area is not in contact with the body during service. The handset, in this device, is electrically powered by a battery.” Seo at Abstract.”

“In this case, therefore, the end of a call cannot be confirmed by the handset in the conventional method, and in the hitherto cordless telephone, a pilot lamp is built in the handset as the device for display. This lamp is lit while the handset is in service. Further, by pressing the disconnect or hang up button on the handset after the call is complete, the pilot lamp goes out.” Seo at 1:19-27.

“It is hence a primary object of the invention to present a novel cordless telephone capable of, by solving the above mentioned technical problems, stopping the display action by the display device while the handset is in service so as to minimize the wasteful consumption of the electric power supplied from the battery or the like.” Seo at 1:36-42.

“To achieve the above object, the cordless telephone of the invention comprises:

- (a) a base unit connected to a telephone line so as to communicate by radio waves for talking, and
- (b) a handset comprising:
 - (b1) a speaker,
 - (b2) a microphone,
 - (b3) a transmitting and receiving circuit for communicating with the base unit by radio waves, transforming the signals from the caller into acoustic sound in the speaker, and sending the output from the microphone to the caller, and

(b4) a battery for providing the transmitting and receiving circuit with electric power, wherein

(c) the handset further comprises:

(c1) a device for display to indicate the in-service state,

(c2) a device for detecting the contact of the speaker area with a part of the body,

(c3) a device for detecting the talk to detect the in-service state, and

(c4) a device for controlling to stop the display action of the display a device when the speaker area is in contact with a part of the body and is in service, in response to the output from the contact detecting device and talk detecting device, and to effect the display action by the display device while the speaker area is not in contact with the body during service, and

(c5) the handset is electrically powered by the battery.

Preferably, the display device is a light emitting diode.” Seo at 1:43-2:4.

“The invention also relates to a cordless telephone having a base unit connected to a telephone line and a handset connected to the base unit through radio communication and equipped with a device for display so as to indicate the in-service state by the handset by the display device, which includes:

a device for detecting contact when a part of the body of the user contacts an area proximate to the speaker, and

a device for stopping the display to stop the display action by the display device when a part of the body of the user is in contact with the area proximate to the speaker of the handset, in response to the detection signal from the contact detecting device.

According to invention, when the contact of a part of the body of the user with an area proximate to the speaker of the handset is detected by the contact detecting device, the

display action of the display device is stopped by the display stopping device while a part of the body of the user is in contact with the area proximate to the speaker of the handset. When the part of the body of the user is departed from the area proximate to the speaker of the handset, the display action of the display device is affected again.

Thus, according to the cordless telephone of the invention, while talking, as long as a part of the body of the user remains in contact with the area proximate to the handset, the display action by the display device is not affected to display the in-service state, so that the consumption of the battery while the handset is in service can be minimized.”
See at 2:16-47.

“FIG. 1 is a perspective view showing the entire structure of a cordless telephone 21 according to an embodiment of the invention. The cordless telephone 21 is connected to a telephone line 22, and include a handset 25 and a base unit 23 for radio communication therewith, the base unit 23 having an antenna 24 for radio communication with the handset 25. The handset 25 includes key switches 2 such as numeric keys as a dial input device provided inside the grip of a handset unit 1; a light emitting element 3 as a display device composed of a light emitting diode (LED) or the like disposed in the vicinity of the key switches 2 inside the grip; a disconnect or hang-up button 4 as the talk completion device for changing over between line capturing state and talk waiting state; a transmitter 5 with a microphone 14 built in and located near the mouth of the user; a receiver 6 containing a piezoelectric element 7 known as touch sensor or the like as the contact detecting device when contacting with the ear, that is, a part of the body of the user contacted while talking; an antenna 8 for communicating with the base unit 23; and a battery 28.” See at 3:1-22.”

Fig 1

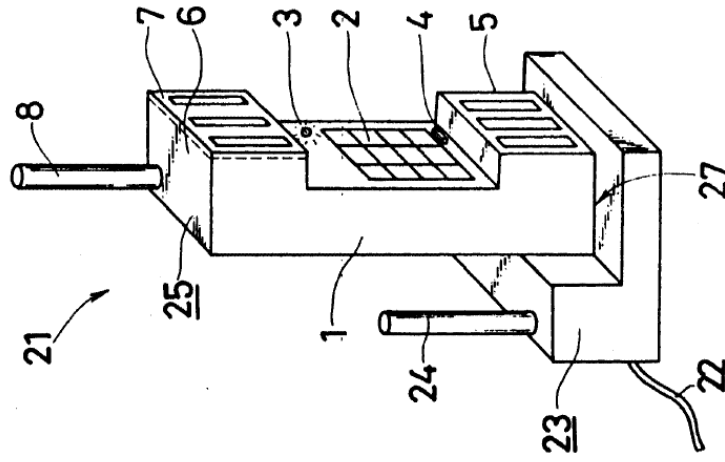

See at Fig. 1.

“FIG. 2 is a block diagram showing a schematic electrical construction of the cordless telephone 21.

In this diagram, a key signal by the operation of the key switch 2 is given to a control circuit 11 which is a device for controlling the members in the handset 25. It is also sent out from the antenna 8 through a transmitting and receiving circuit 13, and is

received through the antenna 24 of the base unit 23. It is then sent out to the telephone at the destination through the telephone line 22. Further, by the key signal from the key switch 2, the control circuit 11 sends out a drive signal to a driver 12 for lighting up the light emitting element 3. Thus, the driver 12 is driven to light up the light emitting element 3. In the meantime, a signal from the piezoelectric element 7 is applied to the control circuit 11, and a stop signal is sent out to the driver 12 from this piezoelectric element 7. Thus, driving of the driver 12 is stopped to extinguish the light emitting element 3. At the same time, the control circuit 11 sends out a control signal to the transmitting and receiving circuit 13. The transmitting and receiving circuit 13 amplifies and modulates the transmission signal received from a microphone 14 built in the transmitter 5. It then sends out a signal from the antenna 8, and demodulates and amplifies the reception signal sent from the antenna 23 through the telephone line 22 which is a communication circuit. Finally, it sends out a signal to a speaker 15 built in the receiver 6. Thus, an acoustic signal is delivered from the speaker 15. Such a handset 25 is electrically powered by a built-in battery 28." Seo at 3:23-52.

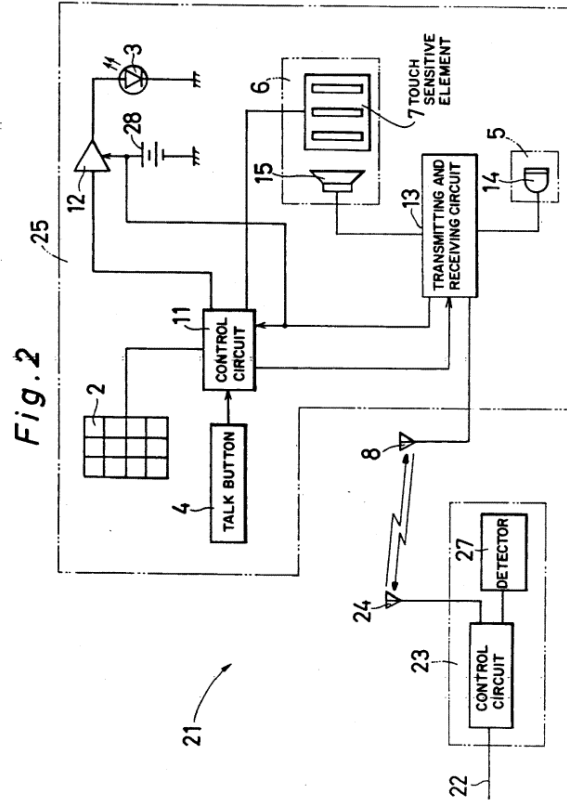

See at Fig. 2.

“First, at step m1 in FIG. 3, the talking action is started. The handset 25 is unhooked from the base unit 23 by the caller at step m2. Unhooking is detected by the handset unhook detecting switch 27.

At step n1 in FIG. 4, when the key switch 2 is operated and the telephone circuit 22 is connected at step n2, a drive signal is issued from the control circuit 11 to the driver 12. Further, when the talk button 4 is not pressed at step n3, the operation goes to step n5. Then when the line is busy, the operation advances to step n6. When the receiver 6 is not in contact with the user's ear, the light emitting element 3 lights up at step n8. In this state, when the user touches the receiver 6 of the handset by the ear, it is detected by the piezoelectric element 7, and the detection signal is sent out to the control circuit 11. The control circuit 11, on the basis of this detection signal, sends out a stop signal to the driver 12. Thus, driving of the driver 12 is stopped, and the light emitting element 3 is extinguished at step n7. Afterwards, when the user's ear is departed again from the piezoelectric element 7, the control circuit 11 then sends out a drive signal to the driver 12 to drive the driver 12. This thereby lights the light emitting element 3 again. Afterwards, by pressing the hang-up button 4 at step n3, a communication circuit cut-off signal is sent out from the handset 25 to the base unit 23 at step n4. Thus the base unit 23 receives the communication circuit signal at step m4 in FIG. 3. Then the connection with the telephone line 22 is cut off at step m5, so that the light emitting element 3 of the handset 25 goes out.

In this way, while the handset 25 is in service, the light emitting element 3 is being extinguished, and the consumption of the battery 28 can be considerably reduced.” See at 3:55-4:21.

Fig. 3

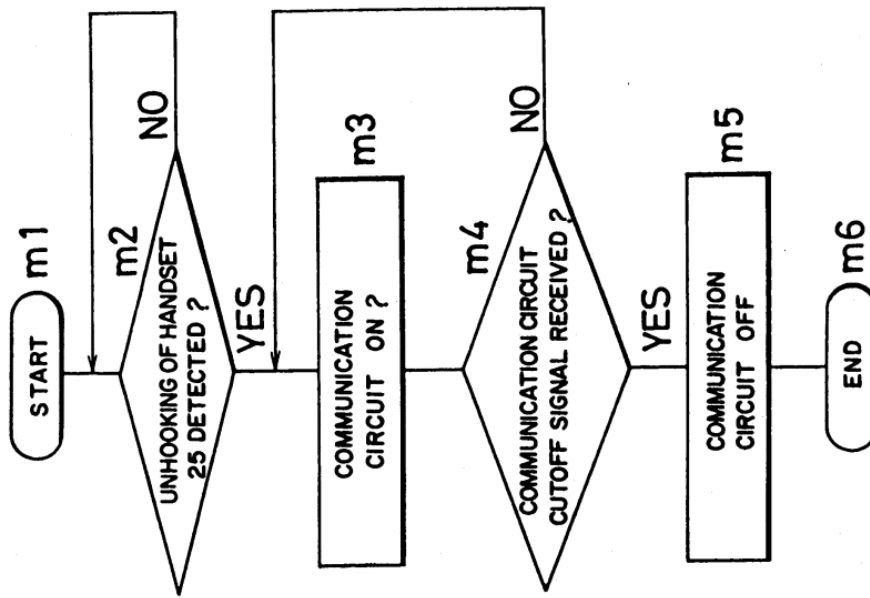

See at Fig. 3.

Fig. 4

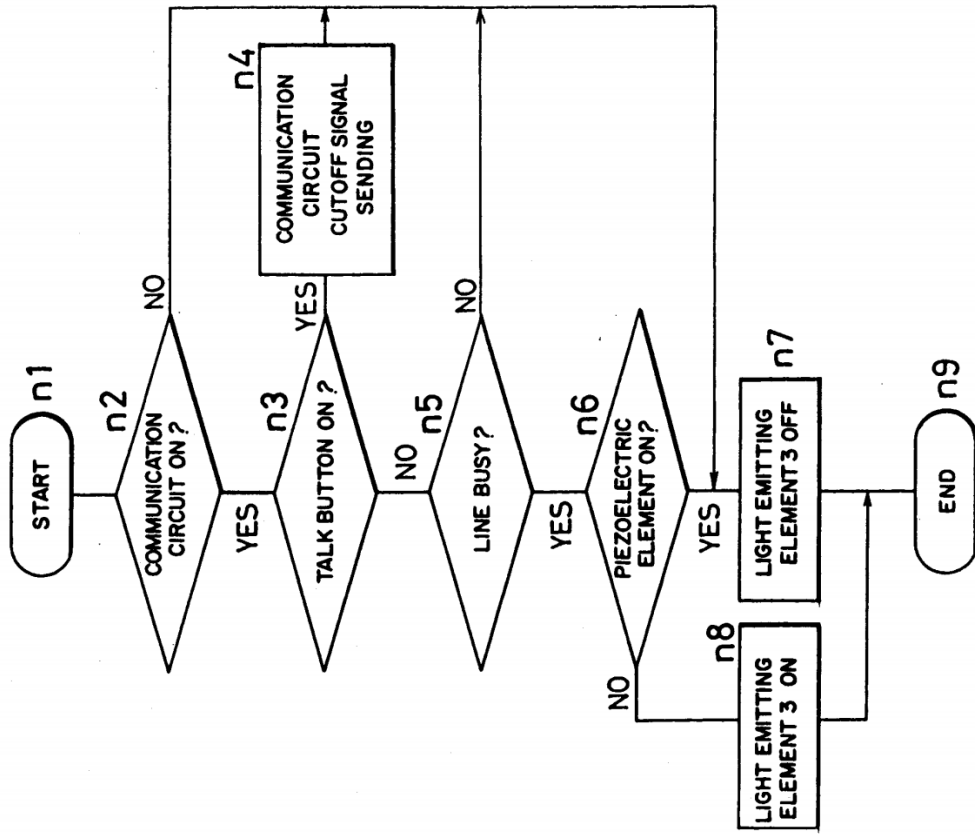

See at Fig. 4.

“1. A cordless telephone apparatus including a base unit connected to a telephone line for communication, and a handset, operatively connected to the base unit by radio waves, including a speaker, a microphone, a transmitting and receiving circuit for communicating with the base unit by radio waves, transforming the signals from a caller into acoustic sound by the speaker, and second the output from the microphone to the caller, and a battery for providing the transmitting and receiving circuit with electric power, the handset further comprising:

display means for indicating an in-service state of the cordless telephone activated for communication;

contact detecting means for detecting contact of a user with an area proximate to the speaker;

activation detecting means for detecting activation of the cordless telephone for communications to detect the in-service state; and

control means operatively connected to the display means, the contact detecting means and the activation detecting means, for controlling the display means to stop indicating an in-service state when an area proximate to the speaker is detected to be in contact with a user and an in service state is detected, in response to the contact detecting means and activation detecting means, and for controlling the display means to indicate an in-service state when an area proximate to the speaker is not detected to be in contact with a user and an in service state is detected; and

the handset battery means for electrically powering the handset.” Seo at claim 1.

“5. The cordless telephone apparatus of claim 1, wherein the contact detecting means includes a penetration hole in an area proximate to the speaker, the speaker being disposed behind the contact detecting means.” Seo at claim 5.

“6. A cordless telephone apparatus including a base unit connected to a telephone line and a handset operatively connected to the base unit via radio communication and

equipped with a display device for indicating an in-service state of the handset, the handset comprising:

contact detecting means for detecting contact when a part of the body of the user contacts with an area proximate to a speaker of the handset, and

stopping means for stopping the display device from indicating the in-service state when a part of the body of the user is detected to be in contact with an area proximate to the speaker of the handset, in response to the contact detecting means.” Seo at claim 6.

“7. A handset of a cordless telephone including a base unit and the handset including a speaker and a transmitter for communicating, by radio communications, with the base unit, the handset further comprising:

display means for displaying indication of the cordless telephone being in-service;

detecting means for emitting a signal upon detecting contact of a user to an area of the handset in close proximity to the speaker; and

control means, operatively connected to said display means and said detecting means, for controlling said display means to display indication of the cordless telephone being in-service upon not receiving an output signal from said detecting means when the cordless telephone is in service and for controlling said display means to stop displaying indication of the cordless telephone being in-service upon receiving an output signal from the detecting means when the cordless telephone is in service.” Seo at claim 7.

“9. The handset of claim 7, wherein the detecting means is a piezoelectric element and the piezoelectric element is disposed in close proximity to the speaker.” Seo at claim 9.

“12. The handset of claim 11, wherein the detecting means is a piezoelectric element disposed in close proximity to the speaker.

	<p>13. The handset of claim 12, wherein the piezoelectric element detects contact of the user's ear to the handset, proximate to the speaker, and outputs a signal.” Seo at claims 12-13.</p> <p>“16. A method of conserving power of a battery in a cordless telephone, including a handset with a battery, a speaker and a receiver and further including a base unit, which indicates to a user when the cordless telephone is in-service, comprising the steps of:</p> <ul style="list-style-type: none"> (a) displaying indication, on the handset, of the cordless telephone in-service; (b) supplying power from the battery during said step (a) of displaying; (c) detecting contact of a user to an area of the handset in close proximity to the speaker; (d) inhibiting said step (a) of displaying by stopping said step (b) of supplying power upon detecting contact in step (c) to thus conserve battery power while said telephone is in-service.” Seo at claim 17. <p>“18. The method of claim 16, wherein said step (c) of detecting contact detects contact of a user's ear to an area of the handset in close proximity to the speaker.” Seo at claim 18.</p>
<p>[1g] the telephone call is a wireless telephone call;</p>	<p>Seo discloses the telephone call as a wireless telephone call.</p> <p>For example: <i>see</i> discussion of claim element 1[d], <i>supra</i>, which is incorporated herein by reference.</p> <p>“CORDLESS TELEPHONE.” Seo at Title.</p>

“A cordless telephone includes a base unit connected to a telephone line so as to communicate by radio waves for talking and a handset. The handset includes a speaker, a microphone, and a transmitting and receiving circuit for communicating with the base unit by radio waves, transforming the signals from the caller into acoustic sound by the speaker, and sending the output from the microphone to the caller. The handset further includes a battery for providing the transmitting and receiving circuit with electric power. Still further, the handset includes a device for display to indicate the in-service state, a device for detecting the contact of the speaker area with a part of the body, a device for detecting talking to detect the in-service state, and a device for controlling to stop the display action of the display device when the speaker area is in contact with a part of the body and is in service this stopping of the display device occurs response to the output from the contact detecting device and the talk detecting device. The control device further affects the display action by the display device while the speaker area is not in contact with the body during service. The handset, in this device, is electrically powered by a battery.” See at Abstract.

To the extent Seo is deemed to not expressly disclose that “the telephone call is a wireless telephone call,” Seo inherently discloses this limitation. For example, as recognized in the 889 patent itself, “[m]obile stations have found many uses in today’s world. When paired with a single base station located at a user’s own premises, they are called ‘cordless telephones.’ When they interact with various, geographically distributed cellular base stations, they are called ‘cellular telephones’ or simply ‘cell phones.’” U.S. Patent No. 7,319,889 (“the ‘889 patent”). A person of ordinary skill in the art at the time of the alleged invention would understand that cordless telephone 21, as described in Seo, is necessarily makes wireless calls and that therefore, necessarily “the telephone call is a wireless telephone call” in Seo.

To the extent Seo is deemed to not expressly or inherently disclose that “the telephone call is a wireless telephone call,” Seo renders this limitation obvious to a person of ordinary skill in the art at the time of the alleged invention.” Seo discloses a “cordless telephone” that “includes a base unit connected to a telephone line so as to

communicate by radio waves....” Seo at Abstract. Furthermore, as recognized in the 889 patent itself, “[m]obile stations have found many uses in today’s world. When paired with a single base station located at a user’s own premises, they are called ‘cordless telephones.’ When they interact with various, geographically distributed cellular base stations, they are called ‘cellular telephones’ or simply ‘cell phones.’”) U.S. Patent No. 7,319,889 (“the ‘889 patent”). Seo also discloses a method of conserving the battery power of the handset of the cordless phone. Seo at 1:36-42 (“It is hence a primary object of the invention to present a novel cordless telephone capable of, by solving the above mentioned technical problems, stopping the display action by the display device while the handset is in service so as to minimize the wasteful consumption of the electric power supplied from the battery or the like.”). It would therefore be obvious to a person of ordinary skill in the art at the time of the alleged invention to use Seo’s methods for conserving battery power for any type of mobile station (whether it be a “cordless telephone” or “cellular telephone”). It would therefore be obvious to a person of ordinary skill in the art at the time of the alleged invention that “the telephone call” in Seo could be a “wireless telephone call.” Such a combination would constitute, at least, combining prior art elements according to known methods to yield predictable results, a simple substitution of one known element for another to obtain predictable results, the use of a known technique to improve similar devices in the same way, the application of a known technique to a known device ready for improvement to yield a predictable result, and obvious to try.

To the extent Seo is deemed to not expressly or inherently disclose that “the telephone call is a wireless telephone call,” it would be obvious to combine the disclosure of Seo with those of Fukihara 598 as described in the Fukihara 598 claim chart, which is incorporated herein in its entirety by reference. Seo and Fukihara 598 are both directed to conserving battery power in mobile stations generally and more particularly at conserving battery power in mobile stations by using sensors to detect when the user of the mobile station is in a call and unlikely to be looking at the display (as when, for example, the proximity sensor detects the user’s ear by the mobile station) and to power off the display of mobile stations at such times. Seo at 1:36-42 (“It is hence a primary object of the invention to present a novel cordless telephone capable of, by

solving the above mentioned technical problems, stopping the display action by the display device while the handset is in service so as to minimize the wasteful consumption of the electric power supplied from the battery or the like.”), 3:64-4:5 (When the receiver 6 is not in contact with the user's ear, the light emitting element 3 lights up at step n8. In this state, when the user touches the receiver 6 of the handset by the ear, it is detected by the piezoelectric element 7, and the detection signal is sent out to the control circuit 11. The control circuit 11, on the basis of this detection signal, sends out a stop signal to the driver 12. Thus, driving of the driver 12 is stopped, and the light emitting element 3 is extinguished at step n7.”); Fukiharu 598 at ¶ 0018 (“The present invention, through the use of a structure as described above, enables a reduction in the consumption of battery power, through enabling the lighting devices to be turned OFF when the ear is caused to contact the receiver portion in order to hear the receiver sound during voice communications of a mobile telephone when the lighting devices (backlights) for a liquid crystal display device and keypad portion of a mobile telephone are lit, such as that night.”). A person of ordinary skill in the art at the time of the alleged invention would be motivated to modify Seo such that “the telephone call is a wireless telephone call,” as disclosed in Fukihara 598 for a number of different reasons, including that it would support Seo’s ability to conserve battery power in mobile stations, and doing so would be within the knowledge and ability of a person of ordinary skill in the art at the time of the alleged invention. The combination would constitute, at least, combining prior art elements according to known methods to yield predictable results, a simple substitution of one known element for another to obtain predictable results, the use of a known technique to improve similar devices in the same way, the application of a known technique to a known device ready for improvement to yield a predictable result, and obvious to try.

To the extent Seo is deemed to not expressly or inherently disclose that “the telephone call is a wireless telephone call,” it would be obvious to combine the disclosure of Seo with those of Numazawa as described in the Numazawa claim chart, which is incorporated herein in its entirety by reference. Seo and Numazawa are both directed to conserving battery power in mobile stations generally and more particularly at conserving battery power in mobile stations by using sensors to detect when the user of

the mobile station is in a call and unlikely to be looking at the display (as when, for example, the proximity sensor detects the user's ear by the mobile station) and to power off the display of mobile stations at such times. Seo at 1:36-42 ("It is hence a primary object of the invention to present a novel cordless telephone capable of, by solving the above mentioned technical problems, stopping the display action by the display device while the handset is in service so as to minimize the wasteful consumption of the electric power supplied from the battery or the like."), 3:64-4:5 (When the receiver 6 is not in contact with the user's ear, the light emitting element 3 lights up at step n8. In this state, when the user touches the receiver 6 of the handset by the ear, it is detected by the piezoelectric element 7, and the detection signal is sent out to the control circuit 11. The control circuit 11, on the basis of this detection signal, sends out a stop signal to the driver 12. Thus, driving of the driver 12 is stopped, and the light emitting element 3 is extinguished at step n7."); Numazawa at ¶ Abstract ("To achieve reduced power consumption through stopping operation of unnecessary functions during use of a wireless terminal. A CPU 2 identifies start of a call state through a signal from a signal processing portion 3 for controlling communication with a base station, and identifies, through an output signal from detecting means 6, whether or not a user ear is in contact with a terminal. Upon identification of contact of the ear to the terminal, controlling means 8 are caused to stop the supply of electric power, from a power supply 7, to displaying means 9 for providing information to a user, and lighting means 10, such as a black light."), ¶ 0005-0007 ("In the present invention, control is such that, upon determination that the wireless terminal is in a call, operation of functions believe be unnecessary, due to the user of the terminal being in a call, is stopped, and upon termination of the call, operation of the stopped functions is restarted. Additionally, because it is envisioned that there will also be cases where, even during a call, the face of the user may be separated from the receiver of the terminal, control is performed so as to enable restarting of the operations of the functions that had been stopped as unnecessary, through detecting whether or not the user of the terminal has the receiver in contact with an ear. The achievement of reduced power consumption through stopping operation of functions that become unnecessary in use of the terminal, as described above, can be anticipated to have the effect of extending the life of the power supply, such as a battery."). A person of ordinary skill in the art at the time of the alleged invention would be motivated to modify Seo such that "the telephone call is a wireless telephone call," as disclosed in Numazawa for a number of

different reasons, including that it would support Seo's ability to conserve battery power in mobile stations, and doing so would be within the knowledge and ability of a person of ordinary skill in the art at the time of the alleged invention. The combination would constitute, at least, combining prior art elements according to known methods to yield predictable results, a simple substitution of one known element for another to obtain predictable results, the use of a known technique to improve similar devices in the same way, the application of a known technique to a known device ready for improvement to yield a predictable result, and obvious to try.

To the extent Seo is deemed to not expressly or inherently disclose that "the telephone call is a wireless telephone call," it would be obvious to combine the disclosure of Seo with those of Miyashita as described in the Miyashita claim chart, which is incorporated herein in its entirety by reference. Seo and Miyashita are both directed to conserving battery power in mobile stations generally and more particularly at conserving battery power in mobile stations by using sensors to detect when the user of the mobile station is in a call and unlikely to be looking at the display (as when, for example, the proximity sensor detects the user's ear by the mobile station or a sensor detects that the mobile station is in a vertical orientation) and to power off the display of mobile stations at such times. Seo at 1:36-42 ("It is hence a primary object of the invention to present a novel cordless telephone capable of, by solving the above mentioned technical problems, stopping the display action by the display device while the handset is in service so as to minimize the wasteful consumption of the electric power supplied from the battery or the like."), 3:64-4:5 (When the receiver 6 is not in contact with the user's ear, the light emitting element 3 lights up at step n8. In this state, when the user touches the receiver 6 of the handset by the ear, it is detected by the piezoelectric element 7, and the detection signal is sent out to the control circuit 11. The control circuit 11, on the basis of this detection signal, sends out a stop signal to the driver 12. Thus, driving of the driver 12 is stopped, and the light emitting element 3 is extinguished at step n7."); Miyashita at 1:58-6:3 ("The present invention is directed to solving the problem set forth above. It is therefore an object of the present invention to provide a portable telephone set which can shut off the power supply for a display portion while a content of the display will not be seen during speaking, and thus can

	<p>reduce power consumption.”), 2:6-11 (“In the preferred construction the detector is a gyro. The control apparatus may shut off the power supply for the display when the detector detects the main body at a substantially vertical position. On the other hand, the control may initiate power supply for the display when the detector detects the main body at a substantially horizontal position.”). A person of ordinary skill in the art at the time of the alleged invention would be motivated to modify Seo such that “the telephone call is a wireless telephone call,” as disclosed in Miyashita for a number of different reasons, including that it would support Seo’s ability to conserve battery power in mobile stations, and doing so would be within the knowledge and ability of a person of ordinary skill in the art at the time of the alleged invention. The combination would constitute, at least, combining prior art elements according to known methods to yield predictable results, a simple substitution of one known element for another to obtain predictable results, the use of a known technique to improve similar devices in the same way, the application of a known technique to a known device ready for improvement to yield a predictable result, and obvious to try.</p>
<p>[1h] the microprocessor reduces power to the display while the signal indicates the proximity of the external object only if the microprocessor determines that the wireless telephone call is active; and</p>	<p>Seo discloses that the microprocessor reduces power to the display while the signal indicates the proximity of the external object only if the microprocessor determines that the wireless telephone call is active.</p> <p>For example: <i>see</i> discussion of claim element [1f], <i>supra</i>, which is incorporated herein by reference.</p> <p>“First, at step m1 in FIG. 3, the talking action is started. The handset 25 is unhooked from the base unit 23 by the caller at step m2. Unhooking is detected by the handset unhook detecting switch 27.</p> <p>At step n1 in FIG. 4, when the key switch 2 is operated and the telephone circuit 22 is connected at step n2, a drive signal is issued from the control circuit 11 to the driver 12. Further, when the talk button 4 is not pressed at step n3, the operation goes to step n5. Then when the line is busy, the operation advances to step n6. When the receiver 6 is not in contact with the user’s ear, the light emitting element 3 lights up at step n8. In this state, when the user touches the receiver 6 of the handset by the ear, it is detected</p>

by the piezoelectric element 7, and the detection signal is sent out to the control circuit 11. The control circuit 11, on the basis of this detection signal, sends out a stop signal to the driver 12. Thus, driving of the driver 12 is stopped, and the light emitting element 3 is extinguished at step n7. Afterwards, when the user's car is departed again from the piezoelectric element 7, the control circuit 11 then sends out a drive signal to the driver 12 to drive the driver 12. This thereby lights the light emitting element 3 again. Afterwards, by pressing the hang-up button 4 at step n3, a communication circuit cut-off signal is sent out from the handset 25 to the base unit 23 at step n4. Thus the base unit 23 receives the communication circuit signal at step m4 in FIG. 3. Then the connection with the telephone line 22 is cut off at step m5, so that the light emitting element 3 of the handset 25 goes out.

In this way, while the handset 25 is in service, the light emitting element 3 is being extinguished, and the consumption of the battery 28 can be considerably reduced." Seo at 3:55-4:21.

Fig. 3

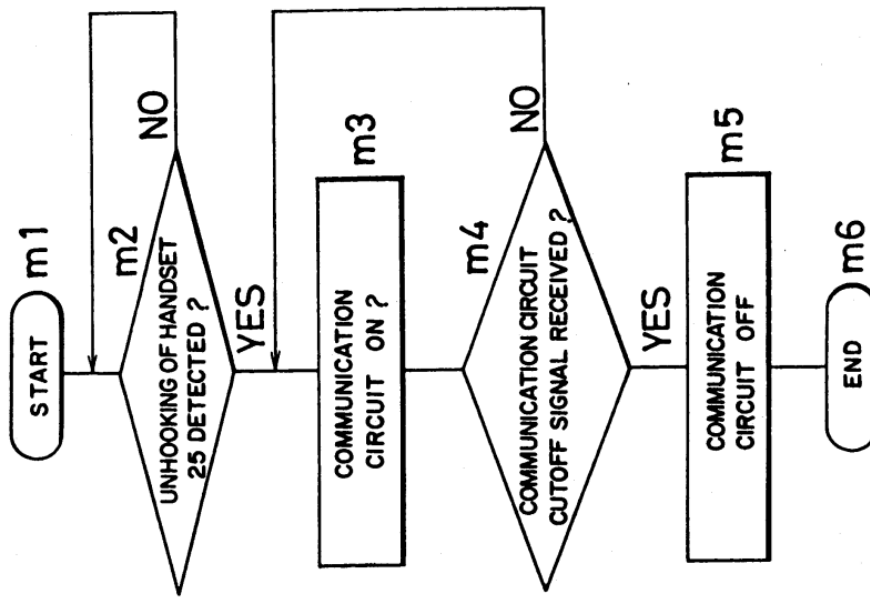

See at Fig. 3.

Fig. 4

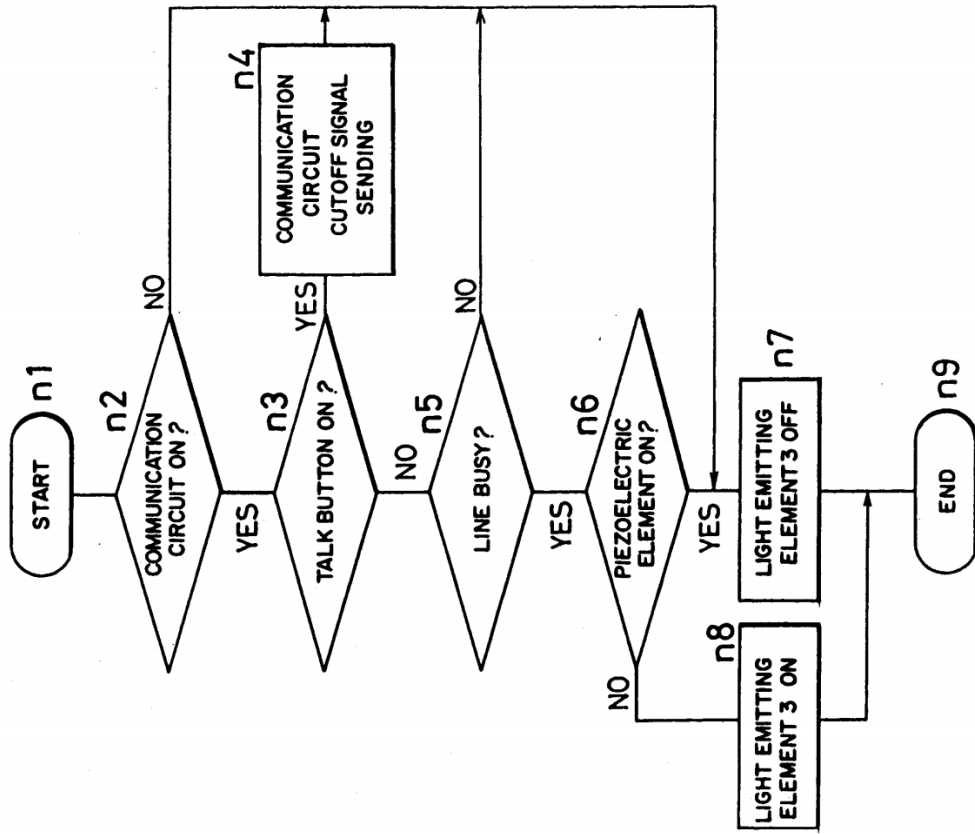

See at Fig. 4.

To the extent Seo is deemed to not expressly disclose that “the microprocessor reduces power to the display while the signal indicates the proximity of the external object only if the microprocessor determines that the wireless telephone call is active,” Seo inherently discloses this limitation. Seo specifies that the step of detecting a signal from the proximity sensor (piezoelectric element 7) is reached only after it is determined that the “line is busy,” and that subsequently the step of the microprocessor (control circuit 11) reducing the power to the display only occurs after the proximity sensor senses the user touching the handset with their ear and sends a detection signal. *See* Seo at 3:62-4:5 (“Further, when the talk button 4 is not pressed at step n3, the operation goes to step n5. Then when the line is busy, the operation advances to step n6. When the receiver 6 is not in contact with the user’s ear, the light emitting element 3 lights up at step n8. In this state, when the user touches the receiver 6 of the handset by the ear, it is detected by the piezoelectric element 7, and the detection signal is sent out to the control circuit 11. The control circuit 11, on the basis of this detection signal, sends out a stop signal to the driver 12. Thus, driving of the driver 12 is stopped, and the light emitting element 3 is extinguished at step n7.”), Fig. 4. Further as noted above for element [1d] and incorporated by reference here, Seo discloses or renders obvious the use of a microprocessor. A person of ordinary skill in the art at the time of the alleged invention would understand that, when a mobile station first determines whether a “line is busy,” then determines whether there is contact with a piezoelectric element and then shuts off power to the display based on a detection signal from the piezoelectric element, necessarily “the microprocessor reduces power to the display while the signal indicates the proximity of the external object only if the microprocessor determines that the wireless telephone call is active.” Therefore, a person of ordinary skill in the art at the time of the alleged invention would understand that in Seo, necessarily “the microprocessor reduces power to the display while the signal indicates the proximity of the external object only if the microprocessor determines that the wireless telephone call is active.”

To the extent Seo is deemed to not expressly disclose that “the microprocessor reduces power to the display while the signal indicates the proximity of the external object only if the microprocessor determines that the wireless telephone call is active,” Seo renders this limitation obvious to one of ordinary skill in the art at the time of the alleged invention. Seo specifies that the step of detecting a signal from the proximity sensor (piezoelectric element 7) is reached only after it is determined that the “line is busy,” and that subsequently the step of the microprocessor (control circuit 11) reducing the power to the display only occurs after the proximity sensor senses the user touching the handset with their ear and sends a detection signal. *See* Seo at 3:62-4:5 (“Further, when the talk button 4 is not pressed at step n3, the operation goes to step n5. Then when the line is busy, the operation advances to step n6. When the receiver 6 is not in contact with the user’s ear, the light emitting element 3 lights up at step n8. In this state, when the user touches the receiver 6 of the handset by the ear, it is detected by the piezoelectric element 7, and the detection signal is sent out to the control circuit 11. The control circuit 11, on the basis of this detection signal, sends out a stop signal to the driver 12. Thus, driving of the driver 12 is stopped, and the light emitting element 3 is extinguished at step n7.”), Fig. 4. Further as noted above for element [1d] and incorporated by reference here, Seo discloses or renders obvious the use of a microprocessor. A person of ordinary skill in the art at the time of the alleged invention would find it obvious to implement the microprocessor of Seo to reduce power to the display only if it determines that the “line is busy” and the piezoelectric element indicates the proximity of an external object. Doing so would be a design choice driven by a number of different reasons, including that it would support Seo’s ability to conserve battery power in mobile stations, and doing so would be within the knowledge and ability of a person of ordinary skill in the art at the time of the alleged invention. Doing so would also constitute, at least, combining prior art elements according to known methods to yield predictable results, a simple substitution of one known element for another to obtain predictable results, the use of a known technique

to improve similar devices in the same way, the application of a known technique to a known device ready for improvement to yield a predictable result, and obvious to try.

To the extent Seo is deemed to not expressly or inherently disclose that “the microprocessor reduces power to the display while the signal indicates the proximity of the external object only if the microprocessor determines that the wireless telephone call is active,” it would be obvious to combine the disclosure of Seo with those of Fukihara 598 as described in the Fukihara 598 claim chart, which is incorporated herein in its entirety by reference. Seo and Fukihara 598 are both directed to conserving battery power in mobile stations generally and more particularly at conserving battery power in mobile stations by using sensors to detect when the user of the mobile station is in a call and unlikely to be looking at the display (as when, for example, the proximity sensor detects the user’s ear by the mobile station) and to power off the display of mobile stations at such times. Seo at 1:36-42 (“It is hence a primary object of the invention to present a novel cordless telephone capable of, by solving the above mentioned technical problems, stopping the display action by the display device while the handset is in service so as to minimize the wasteful consumption of the electric power supplied from the battery or the like.”), 3:64-4:5 (When the receiver 6 is not in contact with the user’s ear, the light emitting element 3 lights up at step n8. In this state, when the user touches the receiver 6 of the handset by the ear, it is detected by the piezoelectric element 7, and the detection signal is sent out to the control circuit 11. The control circuit 11, on the basis of this detection signal, sends out a stop signal to the driver 12. Thus, driving of the driver 12 is stopped, and the light emitting element 3 is extinguished at step n7.”); Fukiharu 598 at ¶ 0018 (“The present invention, through the use of a structure as described above, enables a reduction in the consumption of battery power, through enabling the lighting devices to be turned OFF when the ear is caused to contact the receiver portion in order to hear the receiver sound during voice communications of a mobile telephone when the lighting devices (backlights) for a liquid crystal display device and keypad portion of a mobile telephone are lit, such as that night.”). A person of ordinary skill in the art at the time of the alleged invention would be motivated to modify Seo such that “the microprocessor reduces power to the display while the signal indicates the proximity of the external object only if the

microprocessor determines that the wireless telephone call is active,” as disclosed in Fukihara 598 for a number of different reasons, including that it would support Seo’s ability to conserve battery power in mobile stations, and doing so would be within the knowledge and ability of a person of ordinary skill in the art at the time of the alleged invention. The combination would constitute, at least, combining prior art elements according to known methods to yield predictable results, a simple substitution of one known element for another to obtain predictable results, the use of a known technique to improve similar devices in the same way, the application of a known technique to a known device ready for improvement to yield a predictable result, and obvious to try.

To the extent Seo is deemed to not expressly or inherently disclose the microprocessor adapted to that “the microprocessor reduces power to the display while the signal indicates the proximity of the external object only if the microprocessor determines that the wireless telephone call is active,” it would be obvious to combine the disclosure of Seo with those of Numazawa as described in the Numazawa claim chart, which is incorporated herein in its entirety by reference. Seo and Numazawa are both directed to conserving battery power in mobile stations generally and more particularly at conserving battery power in mobile stations by using sensors to detect when the user of the mobile station is in a call and unlikely to be looking at the display (as when, for example, the proximity sensor detects the user’s ear by the mobile station) and to power off the display of mobile stations at such times. Seo at 1:36-42 (“It is hence a primary object of the invention to present a novel cordless telephone capable of, by solving the above mentioned technical problems, stopping the display action by the display device while the handset is in service so as to minimize the wasteful consumption of the electric power supplied from the battery or the like.”), 3:64-4:5 (When the receiver 6 is not in contact with the user’s ear, the light emitting element 3 lights up at step n8. In this state, when the user touches the receiver 6 of the handset by the ear, it is detected by the piezoelectric element 7, and the detection signal is sent out to the control circuit 11. The control circuit 11, on the basis of this detection signal, sends out a stop signal to the driver 12. Thus, driving of the driver 12 is stopped, and the light emitting element 3 is extinguished at step n7.”); Numazawa at ¶ Abstract (“To achieve reduced power consumption through stopping operation of unnecessary

functions during use of a wireless terminal. A CPU 2 identifies start of a call state through a signal from a signal processing portion 3 for controlling communication with a base station, and identifies, through an output signal from detecting means 6, whether or not a user ear is in contact with a terminal. Upon identification of contact of the ear to the terminal, controlling means 8 are caused to stop the supply of electric power, from a power supply 7, to displaying means 9 for providing information to a user, and lighting means 10, such as a black light.’), ¶ 0005-0007 (“In the present invention, control is such that, upon determination that the wireless terminal is in a call, operation of functions believe be unnecessary, due to the user of the terminal being in a call, is stopped, and upon termination of the call, operation of the stopped functions is restarted. Additionally, because it is envisioned that there will also be cases where, even during a call, the face of the user may be separated from the receiver of the terminal, control is performed so as to enable restarting of the operations of the functions that had been stopped as unnecessary, through detecting whether or not the user of the terminal has the receiver in contact with an ear. The achievement of reduced power consumption through stopping operation of functions that become unnecessary in use of the terminal, as described above, can be anticipated to have the effect of extending the life of the power supply, such as a battery.”). A person of ordinary skill in the art at the time of the alleged invention would be motivated to modify Seo such that “the microprocessor reduces power to the display while the signal indicates the proximity of the external object only if the microprocessor determines that the wireless telephone call is active,” as disclosed in Numazawa for a number of different reasons, including that it would support Seo’s ability to conserve battery power in mobile stations, and doing so would be within the knowledge and ability of a person of ordinary skill in the art at the time of the alleged invention. The combination would constitute, at least, combining prior art elements according to known methods to yield predictable results, a simple substitution of one known element for another to obtain predictable results, the use of a known technique to improve similar devices in the same way, the application of a known technique to a known device ready for improvement to yield a predictable result, and obvious to try.

To the extent Seo is deemed to not expressly or inherently disclose that “the microprocessor reduces power to the display while the signal indicates the proximity of the external object only if the microprocessor determines that the wireless telephone call is active,” it would be obvious to combine the disclosure of Seo with those of Miyashita as described in the Miyashita claim chart, which is incorporated herein in its entirety by reference. Seo and Miyashita are both directed to conserving battery power in mobile stations generally and more particularly at conserving battery power in mobile stations by using sensors to detect when the user of the mobile station is in a call and unlikely to be looking at the display (as when, for example, the proximity sensor detects the user’s ear by the mobile station or a sensor detects that the mobile station is in a vertical orientation) and to power off the display of mobile stations at such times. Seo at 1:36-42 (“It is hence a primary object of the invention to present a novel cordless telephone capable of, by solving the above mentioned technical problems, stopping the display action by the display device while the handset is in service so as to minimize the wasteful consumption of the electric power supplied from the battery or the like.”), 3:64-4:5 (When the receiver 6 is not in contact with the user’s ear, the light emitting element 3 lights up at step n8. In this state, when the user touches the receiver 6 of the handset by the ear, it is detected by the piezoelectric element 7, and the detection signal is sent out to the control circuit 11. The control circuit 11, on the basis of this detection signal, sends out a stop signal to the driver 12. Thus, driving of the driver 12 is stopped, and the light emitting element 3 is extinguished at step n7.”); Miyashita at 1:58-63 (“The present invention is directed to solving the problem set forth above. It is therefore an object of the present invention to provide a portable telephone set which can shut off the power supply for a display portion while a content of the display will not be seen during speaking, and thus can reduce power consumption.”), 2:6-11 (“In the preferred construction the detector is a gyro. The control apparatus may shut off the power supply for the display when the detector detects the main body at a substantially vertical position. On the other hand, the control may initiate power supply for the display when the detector detects the main body at a substantially horizontal position.”). A person of ordinary skill in the art at the time of the alleged invention would be motivated to modify Seo such that “the microprocessor reduces power to the display while the signal indicates the proximity of the external object only if the microprocessor determines that the wireless telephone call is active,” as disclosed in Miyashita for a number of different reasons, including that it would support Seo’s

	<p>ability to conserve battery power in mobile stations, and doing so would be within the knowledge and ability of a person of ordinary skill in the art at the time of the alleged invention. The combination would constitute, at least, combining prior art elements according to known methods to yield predictable results, a simple substitution of one known element for another to obtain predictable results, the use of a known technique to improve similar devices in the same way, the application of a known technique to a known device ready for improvement to yield a predictable result, and obvious to try.</p>
<p>[1i] the proximity sensor begins detecting whether an external object is proximate substantially concurrently with the mobile station initiating an outgoing wireless telephone call or receiving an incoming wireless telephone call.</p>	<p>Seo discloses that the proximity sensor begins to detect whether an external object is proximate substantially concurrently with the mobile station initiating an outgoing wireless telephone call or receiving an incoming wireless telephone call:</p> <p>For example: <i>see</i> discussion of claim elements [1f] and [1h], <i>supra</i>, which are incorporated herein by reference.</p> <p>“First, at step m1 in FIG. 3, the talking action is started. The handset 25 is unhooked from the base unit 23 by the caller at step m2. Unhooking is detected by the handset unhook detecting switch 27.</p> <p>At step n1 in FIG. 4, when the key switch 2 is operated and the telephone circuit 22 is connected at step n2, a drive signal is issued from the control circuit 11 to the driver 12. Further, when the talk button 4 is not pressed at step n3, the operation goes to step n5. Then when the line is busy, the operation advances to step n6. When the receiver 6 is not in contact with the user's ear, the light emitting element 3 lights up at step n8. In this state, when the user touches the receiver 6 of the handset by the ear, it is detected by the piezoelectric element 7, and the detection signal is sent out to the control circuit 11. The control circuit 11, on the basis of this detection signal, sends out a stop signal to the driver 12. Thus, driving of the driver 12 is stopped, and the light emitting element 3 is extinguished at step n7. Afterwards, when the user's ear is departed again from the piezoelectric element 7, the control circuit 11 then sends out a drive signal to</p>

the driver 12 to drive the driver 12. This thereby lights the light emitting element 3 again. Afterwards, by pressing the hang-up button 4 at step n3, a communication circuit cut-off signal is sent out from the handset 25 to the base unit 23 at step n4. Thus the base unit 23 receives the communication circuit signal at step m4 in FIG. 3. Then the connection with the telephone line 22 is cut off at step m5, so that the light emitting element 3 of the handset 25 goes out.

In this way, while the handset 25 is in service, the light emitting element 3 is being extinguished, and the consumption of the battery 28 can be considerably reduced.” Seo at 3:55-4:21.

Fig. 3

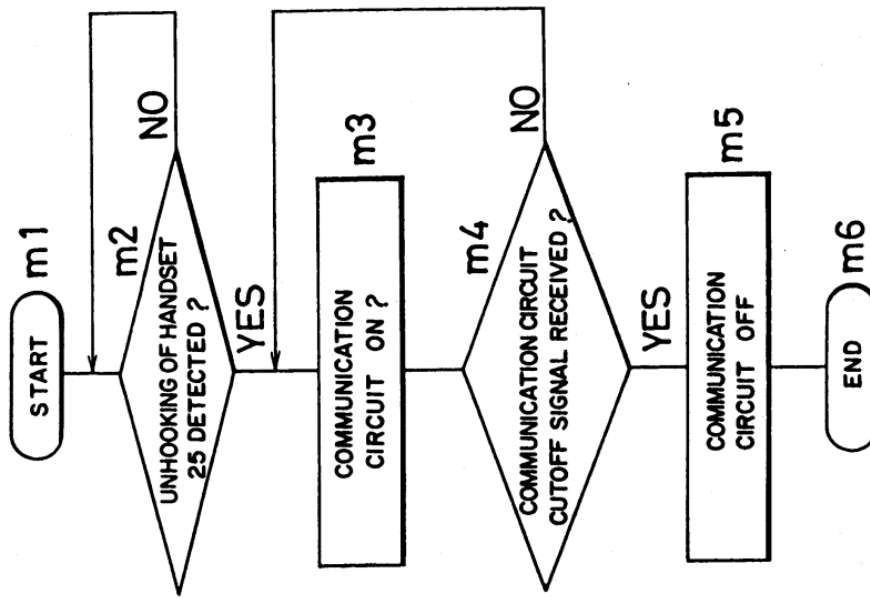

See at Fig. 3.

Fig. 4

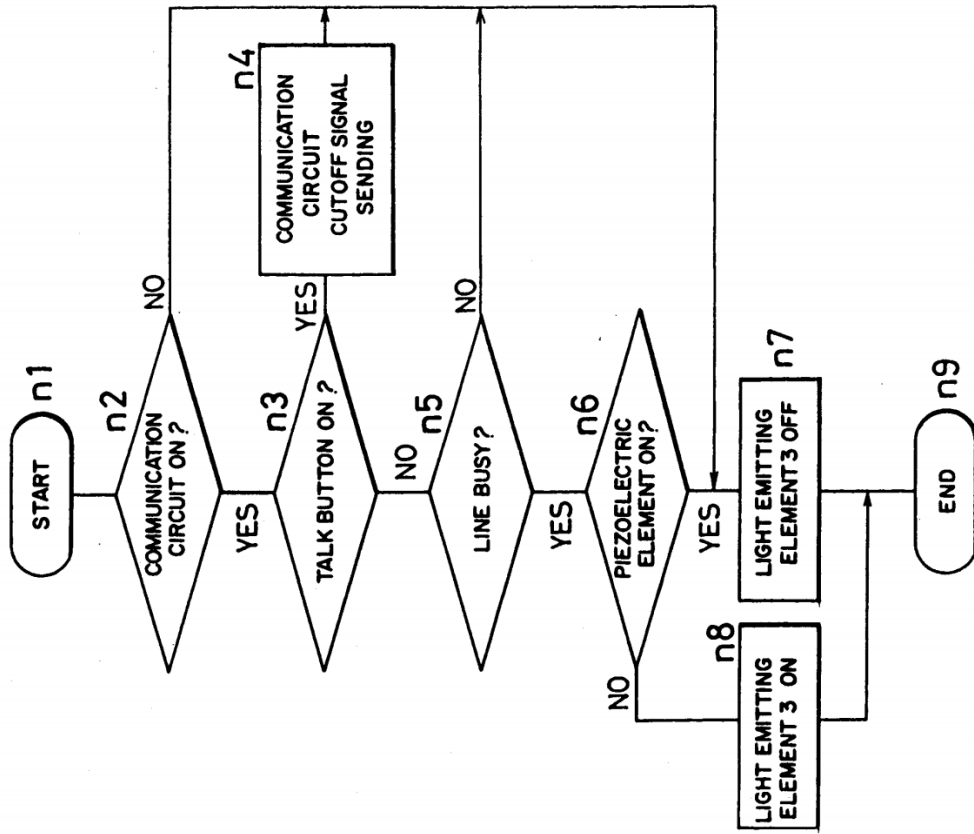

See at Fig. 4.

To the extent Seo is deemed to not expressly disclose “the proximity sensor begins detecting whether an external object is proximate substantially concurrently with the mobile station initiating an outgoing wireless telephone call or receiving an incoming wireless telephone call,” Seo inherently discloses this limitation. In Seo, the microprocessor (control circuit 11) monitors the signal from the proximity sensor (piezoelectric element 7) only after the microprocessor determines that the line is busy. *See* discussion of claim element 1[h], *supra*, incorporate herein by reference. A person of ordinary skill in the art at the time of the alleged invention would understand that “initiating an outgoing wireless telephone call or receiving an incoming wireless telephone call” is how a line becomes busy. Further, a person of ordinary skill in the art would understand that “the proximity sensor begins detecting whether an external object is proximate substantially concurrently with the mobile station initiating an outgoing wireless telephone call or receiving an incoming wireless telephone call” because Seo discloses that this is when the microprocessor monitors the signal from the proximity sensor. Thus, a person of ordinary skill in the art at the time of the alleged invention would understand Seo to inherently disclose that “the proximity sensor begins detecting whether an external object is proximate substantially concurrently with the mobile station initiating an outgoing wireless telephone call or receiving an incoming wireless telephone call.”

To the extent Seo is deemed to not expressly or inherently disclose “the proximity sensor begins detecting whether an external object is proximate substantially concurrently with the mobile station initiating an outgoing wireless telephone call or receiving an incoming wireless telephone call,” Seo renders it obvious to one of skill in the art to have “the proximity sensor begin[] detecting whether an external object is proximate substantially concurrently with the mobile station initiating an outgoing wireless telephone call or receiving an incoming wireless telephone call.” A person of ordinary skill in the art at the time of the alleged invention would understand that “initiating an outgoing wireless telephone call or receiving an incoming wireless telephone call” is how a line becomes busy. Further, it would be obvious to a person of ordinary skill in the art at the time of the alleged invention for “the proximity sensor [to] begin[] detecting whether an external object is proximate substantially concurrently

with the mobile station initiating an outgoing wireless telephone call or receiving an incoming wireless telephone call” because that is the only time when Seo discloses that this is when the microprocessor monitors the signal from the proximity sensor. Because this is the only time that the signal is monitored, it would be obvious to a person of ordinary skill in the art at the time of the alleged invention that the proximity sensor should begin detecting substantially concurrently with the start of this period in order to save additional power.

To the extent Seo is deemed to not expressly or inherently disclose “the proximity sensor begins detecting whether an external object is proximate substantially concurrently with the mobile station initiating an outgoing wireless telephone call or receiving an incoming wireless telephone call,” it would be obvious to combine the disclosure of Seo with those of Fukiharu 598 as described in the Fukiharu 598 claim chart, which is incorporated herein in its entirety by reference. Seo and Fukiharu 598 are both directed to conserving battery power in mobile stations generally and more particularly at conserving battery power in mobile stations by using sensors to detect when the user of the mobile station is in a call and unlikely to be looking at the display (as when, for example, the proximity sensor detects the user’s ear by the mobile station) and to power off the display of mobile stations at such times. Seo at 1:36-42 (“It is hence a primary object of the invention to present a novel cordless telephone capable of, by solving the above mentioned technical problems, stopping the display action by the display device while the handset is in service so as to minimize the wasteful consumption of the electric power supplied from the battery or the like.”), 3:64-4:5 (When the receiver 6 is not in contact with the user’s ear, the light emitting element 3 lights up at step n8. In this state, when the user touches the receiver 6 of the handset by the ear, it is detected by the piezoelectric element 7, and the detection signal is sent out to the control circuit 11. The control circuit 11, on the basis of this detection signal, sends out a stop signal to the driver 12. Thus, driving of the driver 12 is stopped, and the light emitting element 3 is extinguished at step n7.”); Fukiharu 598 at ¶ 0018 (“The present invention, through the use of a structure as described above, enables a reduction in the consumption of battery power, through enabling the lighting devices to be turned OFF when the ear is caused to contact the receiver portion in order to

hear the receiver sound during voice communications of a mobile telephone when the lighting devices (backlights) for a liquid crystal display device and keypad portion of a mobile telephone are lit, such as that night.”). A person of ordinary skill in the art at the time of the alleged invention would be motivated to modify Seo to have “the proximity sensor begin[] detecting whether an external object is proximate substantially concurrently with the mobile station initiating an outgoing wireless telephone call or receiving an incoming wireless telephone call” as disclosed in Fukiharu 598 because the proximity sensor does not need to be detecting when its output is not being monitored, and beginning detecting only during the period when the signal is being monitored would save additional power. The combination would constitute, at least, combining prior art elements according to known methods to yield predictable results, a simple substitution of one known element for another to obtain predictable results, the use of a known technique to improve similar devices in the same way, the application of a known technique to a known device ready for improvement to yield a predictable result, and obvious to try.

To the extent Seo is deemed to not expressly or inherently disclose “the proximity sensor begins detecting whether an external object is proximate substantially concurrently with the mobile station initiating an outgoing wireless telephone call or receiving an incoming wireless telephone call,” it would be obvious to combine the disclosure of Seo with those of Numazawa as described in the Numazawa claim chart, which is incorporated herein in its entirety by reference. Seo and Numazawa are both directed to conserving battery power in mobile stations generally and more particularly at conserving battery power in mobile stations by using sensors to detect when the user of the mobile station is in a call and unlikely to be looking at the display (as when, for example, the proximity sensor detects the user’s ear by the mobile station) and to power off the display of mobile stations at such times. Seo at 1:36-42 (“It is hence a primary object of the invention to present a novel cordless telephone capable of, by solving the above mentioned technical problems, stopping the display action by the display device while the handset is in service so as to minimize the wasteful consumption of the electric power supplied from the battery or the like.”), 3:64-4:5 (When the receiver 6 is not in contact with the user’s ear, the light emitting element 3

lights up at step n8. In this state, when the user touches the receiver 6 of the handset by the ear, it is detected by the piezoelectric element 7, and the detection signal is sent out to the control circuit 11. The control circuit 11, on the basis of this detection signal, sends out a stop signal to the driver 12. Thus, driving of the driver 12 is stopped, and the light emitting element 3 is extinguished at step n7.”); Numazawa at ¶ Abstract (“To achieve reduced power consumption through stopping operation of unnecessary functions during use of a wireless terminal. A CPU 2 identifies start of a call state through a signal from a signal processing portion 3 for controlling communication with a base station, and identifies, through an output signal from detecting means 6, whether or not a user ear is in contact with a terminal. Upon identification of contact of the ear to the terminal, controlling means 8 are caused to stop the supply of electric power, from a power supply 7, to displaying means 9 for providing information to a user, and lighting means 10, such as a black light.”), ¶ 0005-0007 (“In the present invention, control is such that, upon determination that the wireless terminal is in a call, operation of functions believe be unnecessary, due to the user of the terminal being in a call, is stopped, and upon termination of the call, operation of the stopped functions is restarted. Additionally, because it is envisioned that there will also be cases where, even during a call, the face of the user may be separated from the receiver of the terminal, control is performed so as to enable restarting of the operations of the functions that had been stopped as unnecessary, through detecting whether or not the user of the terminal has the receiver in contact with an ear. The achievement of reduced power consumption through stopping operation of functions that become unnecessary in use of the terminal, as described above, can be anticipated to have the effect of extending the life of the power supply, such as a battery.”) A person of ordinary skill in the art at the time of the alleged invention would be motivated to modify Seo to have “the proximity sensor begin[] detecting whether an external object is proximate substantially concurrently with the mobile station initiating an outgoing wireless telephone call or receiving an incoming wireless telephone call” as disclosed in Numazawa because the proximity sensor does not need to be detecting when its output is not being monitored, and beginning detecting only during the period when the signal is being monitored would save additional power. The combination would constitute, at least, combining prior art elements according to known methods to yield predictable results, a simple substitution of one known element for another to obtain predictable results, the use of a known technique to improve similar devices in the same way, the application of a

known technique to a known device ready for improvement to yield a predictable result, and obvious to try.

To the extent Seo is deemed to not expressly or inherently disclose “the proximity sensor begins detecting whether an external object is proximate substantially concurrently with the mobile station initiating an outgoing wireless telephone call or receiving an incoming wireless telephone call,” it would be obvious to combine the disclosure of Seo with those of Miyashita as described in the Miyashita claim chart, which is incorporated herein in its entirety by reference. Seo and Miyashita are both directed to conserving battery power in mobile stations generally and more particularly at conserving battery power in mobile stations by using sensors to detect when the user of the mobile station is in a call and unlikely to be looking at the display (as when, for example, the proximity sensor detects the user’s ear by the mobile station or a sensor detects that the mobile station is in a vertical orientation) and to power off the display of mobile stations at such times. Seo at 1:36-42 (“It is hence a primary object of the invention to present a novel cordless telephone capable of, by solving the above mentioned technical problems, stopping the display action by the display device while the handset is in service so as to minimize the wasteful consumption of the electric power supplied from the battery or the like.”), 3:64-4:5 (When the receiver 6 is not in contact with the user’s ear, the light emitting element 3 lights up at step n8. In this state, when the user touches the receiver 6 of the handset by the ear, it is detected by the piezoelectric element 7, and the detection signal is sent out to the control circuit 11. The control circuit 11, on the basis of this detection signal, sends out a stop signal to the driver 12. Thus, driving of the driver 12 is stopped, and the light emitting element 3 is extinguished at step n7.”); Miyashita at 3:58-4:2 (“In contrast, the display control portion 17 is responsive to the inclination angle information indicative of variation of the inclination angle from the substantially horizontal orientation to the substantially vertical orientation while it performs display control for the display portion 16 to display the control information, to terminate the power supply for the display portion 16. When speaking is performed with the destination person via the speaker 12 and the microphone 14, it is rare to require seeing the display content on the display portion 16. Therefore, the power supply for the display portion 16 is shut down. Thus, exhausting

	<p>of a battery can be reduced.’). While Miyashita discloses a gyro, it would be obvious to one of ordinary skill in the art at the time of the alleged invention to make Seo’s proximity sensor to function in the same way as the gyro in Miyashita as both sensors serve the same function (to serve as an indication that the mobile station’s display is unlikely to be viewed and can therefore be powered off). A person of ordinary skill in the art at the time of the alleged invention would therefore be motivated to modify Seo to have “the proximity sensor begin[] detecting whether an external object is proximate substantially concurrently with the mobile station initiating an outgoing wireless telephone call or receiving an incoming wireless telephone call” as disclosed in Miyashita because the proximity sensor does not need to be detecting when its output is not being monitored, and beginning detecting only during the period when the signal is being monitored would save additional power. The combination would constitute, at least, combining prior art elements according to known methods to yield predictable results, a simple substitution of one known element for another to obtain predictable results, the use of a known technique to improve similar devices in the same way, the application of a known technique to a known device ready for improvement to yield a predictable result, and obvious to try.</p>
<p>[Claim 2] The mobile station of claim 1, wherein the microprocessor reduces power to the display only if (i) the microprocessor determines that a telephone call is active and (ii) the signal indicates the proximity of the external object.</p>	<p>Seo discloses the microprocessor reducing power to the display only if (i) the microprocessor determines that a telephone call is active and (ii) the signal indicates the proximity of the external object.</p> <p>For example: <i>see</i> discussion of claim element [1f], <i>supra</i>, which is incorporated herein by reference.</p>
<p>[Claim 4] The mobile station as recited in claim 1, wherein the microprocessor reduces power to the display by turning off the display.</p>	<p>Seo discloses the microprocessor reducing power to the display by turning off the display.</p>

	<p>For example: <i>see</i> discussion of claim element [1f], <i>supra</i>, which is incorporated herein by reference.</p>
<p>[Claim 5] The mobile station as recited in claim 1, wherein the proximity sensor is a mechanical proximity sensor, an optical sensor, or a range-detecting sensor.</p>	<p>Seo discloses that the proximity sensor is a mechanical proximity sensor, an optical sensor, or a range-detecting sensor.</p> <p>For example: <i>See</i> discussion of claim element [1b], <i>supra</i>, which is incorporated herein by reference.</p> <p>“According to invention, when the contact of a part of the body of the user with an area proximate to the speaker of the handset is detected by the contact detecting device, the display action of the display device is stopped by the display stopping device while a part of the body of the user is in contact with the area proximate to the speaker of the handset. When the part of the body of the user is departed from the area proximate to the speaker of the handset, the display action of the display device is affected again.</p> <p>Thus, according to the cordless telephone of the invention, while talking, as long as a part of the body of the user remains in contact with the area proximate to the handset, the display action by the display device is not affected to display the in-service state, so that the consumption of the battery while the handset is in service can be minimized.” Seo at 2:16-47.</p> <p>“FIG. 1 is a perspective view showing the entire structure of a cordless telephone 21 according to an embodiment of the invention...a receiver 6 containing a piezoelectric element 7 known as touch sensor or the like as the contact detecting device when contacting with the ear, that is, a part of the body of the user contacted while talking;</p>

an antenna 8 for communicating with the base unit 23; and a battery 28.” Seo at 3:1-22.”

Fig 1

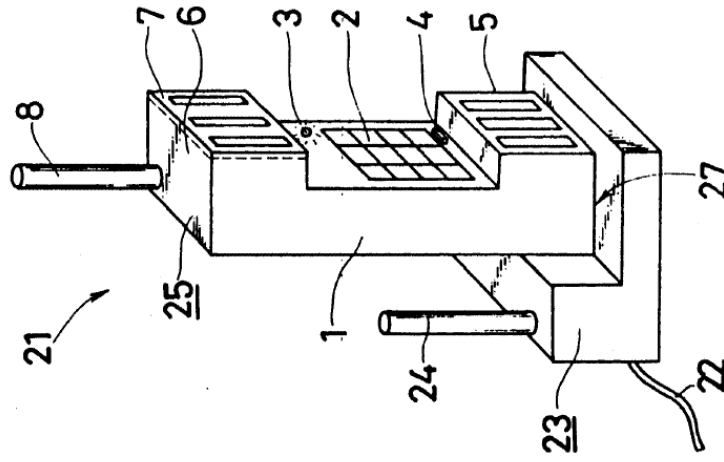

Seo at Fig. 1.

To the extent Seo is deemed to not expressly disclose “the proximity sensor is a mechanical proximity sensor, an optical sensor, or a range-detecting sensor,” Seo inherently discloses this limitation. In Seo, contact detecting device/piezoelectric element 7 is able to detect contact with a portion of the human body, such as an ear. A person of ordinary skill in the art at the time of the alleged invention would understand that detecting this contact is accomplished by mechanical proximity sensor. Thus, a person of ordinary skill in the art at the time of the alleged invention would understand Seo to inherently disclose “the proximity sensor is a mechanical proximity sensor, an optical sensor, or a range-detecting sensor.”

To the extent Seo is deemed to not expressly or inherently disclose “the proximity sensor is a mechanical proximity sensor, an optical sensor, or a range-detecting sensor,” Seo renders it obvious to one of ordinary skill in the art at the time of the alleged invention to use a mechanical proximity sensor. A person of ordinary skill in the art at the time of the alleged invention would be aware of “conventional mechanical proximity (load) sensors,” which the ’889 Patent identifies as known prior art. *See* ’889 Patent at 3:15-20. A person of ordinary skill in the art at the time of the alleged invention would understand that a mechanical proximity sensor could be used to detect contact with a portion of the human body, such as an ear. Using a mechanical proximity sensor would constitute, at least, combining prior art elements according to known methods to yield predictable results, a simple substitution of one known element for another to obtain predictable results, the use of a known technique to improve similar devices in the same way, the application of a known technique to a known device ready for improvement to yield a predictable result, and obvious to try.

[Claim 6] The mobile station as recited in claim 1, wherein the proximity sensor is located proximate to the display.

Seo discloses that the proximity sensor is located proximate to the display.

For example: *See* discussion of claim element [1b], *supra*, which is incorporated herein by reference.

‘FIG. 1 is a perspective view showing the entire structure of a cordless telephone 21 according to an embodiment of the invention. The cordless telephone 21 is connected to a telephone line 22, and include a handset 25 and a base unit 23 for radio communication therewith, the base unit 23 having an antenna 24 for radio communication with the handset 25. The handset 25 includes key switches 2 such as numeric keys as a dial input device provided inside the grip of a handset unit 1; a light emitting element 3 as a display device composed of a light emitting diode (LED) or the like disposed in the vicinity of the key switches 2 inside the grip; a disconnect or hang-up button 4 as the talk completion device for changing over between line capturing state and talk waiting state; a transmitter 5 with a microphone 14 built in and located near the mouth of the user; a receiver 6 containing a piezoelectric element 7 known as touch sensor or the like as the contact detecting device when contacting with the ear, that is, a part of the body of the user contacted while talking; an antenna 8 for communicating with the base unit 23; and a battery 28.’ Seo at 3:1-22.

Fig 1

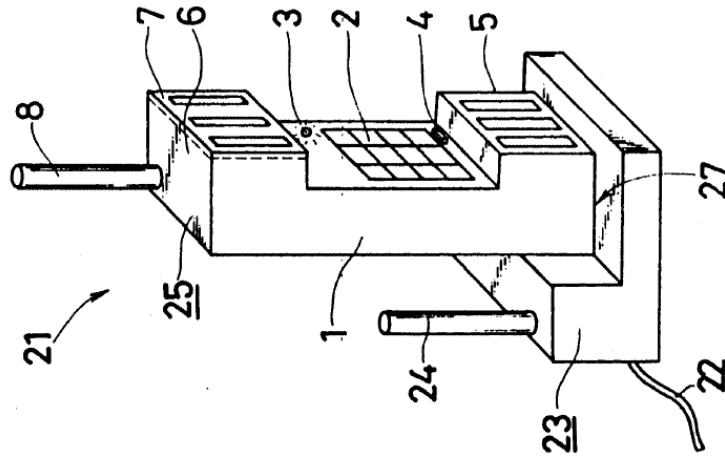

See at Fig. 1.

“ . . . detecting means for emitting a signal upon detecting contact of a user to an area of the handset in close proximity to the speaker; and” See at Claim 7.

“9. The handset of claim 7, wherein the detecting means is a piezoelectric element and the piezoelectric element is disposed in close proximity to the speaker.” See at Claim 9.

“12. The handset of claim 11, wherein the detecting means is a piezoelectric element disposed in close proximity to the speaker.” See at Claim 12.

“... (c) detecting contact of a user to an area of the handset in close proximity to the speaker; ...” See at Claim 16.

“18. The method of claim 16, wherein said step (c) of detecting contact detects contact of a user's ear to an area of the handset in close proximity to the speaker.” See at Claim 18.

To the extent Seo is deemed to not expressly disclose “the proximity sensor is located proximate to the display,” Seo inherently discloses this limitation. Seo discloses that its invention cuts power to the display during a call when the user has the receiver against his or her ear because the display is an unnecessary function at this time, i.e., it is not visible. A person of ordinary skill in the art at the time of the alleged invention would understand that the display is not visible because the user's head is against it and, if the detecting means is to detect this, it should be “located proximate to the display.” Thus, a person of ordinary skill in the art at the time of the alleged invention would understand Seo to inherently disclose that “the proximity sensor is located proximate to the display.”

To the extent Seo is deemed to not expressly or inherently disclose “the proximity sensor is located proximate to the display,” Seo renders it obvious to one of skill in the art to have “the proximity sensor . . . located proximate to the display.” It would be obvious to a person of ordinary skill in the art at the time of the alleged invention that “the proximity sensor is located proximate to the display” because, in this location, it can determine that the display is not visible because the user’s head is against it. This would constitute, at least, combining prior art elements according to known methods to yield predictable results, a simple substitution of one known element for another to obtain predictable results, the use of a known technique to improve similar devices in the same way, the application of a known technique to a known device ready for improvement to yield a predictable result, and obvious to try.

To the extent Seo is deemed to not expressly or inherently disclose “the proximity sensor is located proximate to the display,” it would be obvious to combine the disclosure of Seo with those of Fukiharu 598 as described in the Fukiharu 598 claim chart, which is incorporated herein in its entirety by reference. Seo and Fukiharu 598 are both directed to conserving battery power in mobile stations generally and more particularly at conserving battery power in mobile stations by using sensors to detect when the user of the mobile station is in a call and unlikely to be looking at the display (as when, for example, the proximity sensor detects the user’s ear by the mobile station) and to power off the display of mobile stations at such times. Seo at 1:36-42 (“It is hence a primary object of the invention to present a novel cordless telephone capable of, by solving the above mentioned technical problems, stopping the display action by the display device while the handset is in service so as to minimize the wasteful consumption of the electric power supplied from the battery or the like.”), 3:64-4:5 (When the receiver 6 is not in contact with the user’s ear, the light emitting element 3 lights up at step n8. In this state, when the user touches the receiver 6 of the handset by the ear, it is detected by the piezoelectric element 7, and the detection signal is sent out to the control circuit 11. The control circuit 11, on the basis of this detection signal, sends out a stop signal to the driver 12. Thus, driving of the driver 12 is stopped, and the light emitting element 3 is extinguished at step n7.”); Fukiharu 598 at ¶ 0018 (“The present invention, through the use of a structure as described above, enables a

reduction in the consumption of battery power, through enabling the lighting devices to be turned OFF when the ear is caused to contact the receiver portion in order to hear the receiver sound during voice communications of a mobile telephone when the lighting devices (backlights) for a liquid crystal display device and keypad portion of a mobile telephone are lit, such as that night.”). A person of ordinary skill in the art at the time of the alleged invention would be motivated to modify Seo to have “the proximity sensor is located proximate to the display” as disclosed in Fukiharu 598 to determine that the display is not visible because the user’s head is against it. The combination would constitute, at least, combining prior art elements according to known methods to yield predictable results, a simple substitution of one known element for another to obtain predictable results, the use of a known technique to improve similar devices in the same way, the application of a known technique to a known device ready for improvement to yield a predictable result, and obvious to try.

To the extent Seo is deemed to not expressly or inherently disclose “the proximity sensor is located proximate to the display,” it would be obvious to combine the disclosure of Seo with those of Numazawa as described in the Numazawa claim chart, which is incorporated herein in its entirety by reference. Seo and Numazawa are both directed to conserving battery power in mobile stations generally and more particularly at conserving battery power in mobile stations by using sensors to detect when the user of the mobile station is in a call and unlikely to be looking at the display (as when, for example, the proximity sensor detects the user’s ear by the mobile station) and to power off the display of mobile stations at such times. Seo at 1:36-42 (“It is hence a primary object of the invention to present a novel cordless telephone capable of, by solving the above mentioned technical problems, stopping the display action by the display device while the handset is in service so as to minimize the wasteful consumption of the electric power supplied from the battery or the like.”), 3:64-4:5 (When the receiver 6 is not in contact with the user’s ear, the light emitting element 3 lights up at step n8. In this state, when the user touches the receiver 6 of the handset by the ear, it is detected by the piezoelectric element 7, and the detection signal is sent out to the control circuit 11. The control circuit 11, on the basis of this detection signal, sends out a stop signal to the driver 12. Thus, driving of the driver 12 is stopped, and

the light emitting element 3 is extinguished at step n7.”); Numazawa at ¶ Abstract (“To achieve reduced power consumption through stopping operation of unnecessary functions during use of a wireless terminal. A CPU 2 identifies start of a call state through a signal from a signal processing portion 3 for controlling communication with a base station, and identifies, through an output signal from detecting means 6, whether or not a user ear is in contact with a terminal. Upon identification of contact of the ear to the terminal, controlling means 8 are caused to stop the supply of electric power, from a power supply 7, to displaying means 9 for providing information to a user, and lighting means 10, such as a black light.”), ¶ 0005-0007 (“In the present invention, control is such that, upon determination that the wireless terminal is in a call, operation of functions believe be unnecessary, due to the user of the terminal being in a call, is stopped, and upon termination of the call, operation of the stopped functions is restarted. Additionally, because it is envisioned that there will also be cases where, even during a call, the face of the user may be separated from the receiver of the terminal, control is performed so as to enable restarting of the operations of the functions that had been stopped as unnecessary, through detecting whether or not the user of the terminal has the receiver in contact with an ear. The achievement of reduced power consumption through stopping operation of functions that become unnecessary in use of the terminal, as described above, can be anticipated to have the effect of extending the life of the power supply, such as a battery.”). A person of ordinary skill in the art at the time of the alleged invention would be motivated to modify Seo to have “the proximity sensor is located proximate to the display” as disclosed in Numazawa to determine that the display is not visible because the user’s head is against it. The combination would constitute, at least, combining prior art elements according to known methods to yield predictable results, a simple substitution of one known element for another to obtain predictable results, the use of a known technique to improve similar devices in the same way, the application of a known technique to a known device ready for improvement to yield a predictable result, and obvious to try.

[Claim 8 – Preamble] 8. A method of conserving battery power in a mobile station, comprising:

To the extent the preamble is construed as limiting, Seo discloses a method of conserving battery power in a mobile station:

For example: *see* discussion of claim 1, *supra*, which is incorporated herein by reference.

“In such a conventional cordless telephone, the pilot lamp is usually located near the call button (input key), and it is not at all visible by the user if the speaker area of the handset is fitted to the ear. Accordingly, it is quite meaningless to always light up the pilot lamp always during call by the handset. This only achieved to the battery is spent purposelessly.” Seo at 1:28-34.

“It is hence a primary object of the invention to present a novel cordless telephone capable of, by solving the above mentioned technical problems, stopping the display action by the display device while the handset is in service so as to minimize the wasteful consumption of the electric power supplied from the battery or the like.” Seo at 1:37-42.

“Thus, according to the cordless telephone of the invention, while talking, as long as a part of the body of the user remains in contact with the area proximate to the handset, the display action by the display device is not affected to display the in-service state, so that the consumption of the battery while the handset is in service can be minimized.”

“In this way, while the handset 25 is in service, the light emitting element 3 is being extinguished, and the consumption of the battery 28 can be considerably reduced.” Seo at 2:41-47.

“16. A method of conserving power of a battery in a cordless telephone, including a handset with a battery, a speaker and a receiver and further including a base unit, which indicates to a user when the cordless telephone is in-service, comprising the steps of:

- (a) displaying indication, on the handset, of the cordless telephone in-service;
- (b) supplying power from the battery during said step (a) of displaying;

(c) detecting contact of a user to an area of the handset in close proximity to the speaker;

(d) inhibiting said step (a) of displaying by stopping said step (b) of supplying power upon detecting contact in step (c) to thus conserve battery power while said telephone is in-service.” Seo at claim 16.

To the extent Seo is deemed to not expressly disclose this claim limitation, Seo inherently discloses this limitation. *See* discussion of claim element [1 preamble], *supra*, which is incorporated herein by reference.

To the extent Seo is deemed to not expressly or inherently disclose this claim limitation, Seo renders it obvious to one of skill in the art at the time of the alleged invention. *See* discussion of claim element [1 preamble], *supra*, which is incorporated herein by reference.

To the extent Seo is deemed to not expressly or inherently disclose this claim element, it would be obvious to combine the disclosure of Seo with those of Numazawa as described in the Numazawa claim chart, which is incorporated herein in its entirety by reference. *See* discussion of claim element [1 preamble], *supra*, which is incorporated herein by reference.

To the extent Seo is deemed to not expressly or inherently disclose this claim element, it would be obvious to combine the disclosure of Seo with those of Fukiharu 598 as described in the Fukiharu 598 claim chart, which is incorporated herein in its entirety by reference. *See* discussion of claim element [1 preamble], *supra*, which is incorporated herein by reference.

To the extent Seo is deemed to not expressly or inherently disclose this claim element, it would be obvious to combine the disclosure of Seo with those of Miyashita as described in the Miyashita claim chart, which is incorporated herein in its entirety by reference. *See* discussion of claim element [1 preamble], *supra*, which is incorporated herein by reference.

<p>[8a] detecting whether an external object is proximate;</p>	<p>Seo discloses detecting whether an external object is proximate.</p> <p>For example: <i>see</i> discussion of claim element [1b], <i>supra</i>, which is incorporated herein by reference.</p> <p>To the extent Seo is deemed to not expressly disclose this claim limitation, Seo inherently discloses this limitation. <i>See</i> discussion of claim element [1b], <i>supra</i>, which is incorporated herein by reference.</p>
<p>[8b] determining whether a telephone call is active; and</p>	<p>Seo discloses determining whether a telephone call is active.</p> <p>For example: <i>see</i> discussion of claim element [1d], <i>supra</i>, which is incorporated herein by reference.</p>
<p>[8c] reducing power consumption of a display of the mobile station if (i) a telephone call is determined to be active and (ii) the proximity of the external object is detected; wherein:</p>	<p>Seo discloses reducing power consumption of a display of the mobile station if (i) a telephone call is determined to be active and (ii) the proximity of the external object is detected.</p> <p>For example: <i>see</i> discussion of claim element [1f], <i>supra</i>, which is incorporated herein by reference.</p>
<p>[8d] the telephone call is a wireless telephone call;</p>	<p>Seo discloses that the telephone call is a wireless telephone call.</p> <p>For example: <i>see</i> discussion of claim element [1g], <i>supra</i>, which is incorporated herein by reference.</p>

	<p>To the extent Seo is deemed to not expressly disclose this claim limitation, Seo inherently discloses this limitation. <i>See</i> discussion of claim element [1g], <i>supra</i>, which is incorporated herein by reference.</p> <p>To the extent Seo is deemed to not expressly or inherently disclose this claim limitation, Seo renders it obvious to one of skill in the art at the time of the alleged invention. <i>See</i> discussion of claim element [1g], <i>supra</i>, which is incorporated herein by reference.</p> <p>To the extent Seo is deemed to not expressly or inherently disclose this claim element, it would be obvious to combine the disclosure of Seo with those of Numazawa as described in the Numazawa claim chart, which is incorporated herein in its entirety by reference. <i>See</i> discussion of claim element [1g], <i>supra</i>, which is incorporated herein by reference.</p> <p>To the extent Seo is deemed to not expressly or inherently disclose this claim element, it would be obvious to combine the disclosure of Seo with those of Fukiharu 598 as described in the Fukiharu 598 claim chart, which is incorporated herein in its entirety by reference. <i>See</i> discussion of claim element [1g], <i>supra</i>, which is incorporated herein by reference.</p> <p>To the extent Seo is deemed to not expressly or inherently disclose this claim element, it would be obvious to combine the disclosure of Seo with those of Miyashita as described in the Miyashita claim chart, which is incorporated herein in its entirety by reference. <i>See</i> discussion of claim element [1g], <i>supra</i>, which is incorporated herein by reference.</p>
<p>[8e] the power consumption of the display is reduced while the proximity of the external object is detected only if the wireless telephone call is determined to be active; and</p>	<p>Seo discloses that the power consumption of the display is reduced while the proximity of the external object is detected only if the wireless telephone call is determined to be active.</p>

For example: *see* discussion of claim element [1h], *supra*, which is incorporated herein by reference.

To the extent Seo is deemed to not expressly disclose this claim limitation, Seo inherently discloses this limitation. *See* discussion of claim element [1h], *supra*, which is incorporated herein by reference.

To the extent Seo is deemed to not expressly or inherently disclose this claim limitation, Seo renders it obvious to one of skill in the art at the time of the alleged invention. *See* discussion of claim element [1h], *supra*, which is incorporated herein by reference.

To the extent Seo is deemed to not expressly or inherently disclose this claim element, it would be obvious to combine the disclosure of Seo with those of Numazawa as described in the Numazawa claim chart, which is incorporated herein in its entirety by reference. *See* discussion of claim element [1h], *supra*, which is incorporated herein by reference.

To the extent Seo is deemed to not expressly or inherently disclose this claim element, it would be obvious to combine the disclosure of Seo with those of Fukiharu 598 as described in the Fukiharu 598 claim chart, which is incorporated herein in its entirety by reference. *See* discussion of claim element [1h], *supra*, which is incorporated herein by reference.

To the extent Seo is deemed to not expressly or inherently disclose this claim element, it would be obvious to combine the disclosure of Seo with those of Miyashita as described in the Miyashita claim chart, which is incorporated herein in its entirety by reference. *See* discussion of claim element [1h], *supra*, which is incorporated herein by reference.

[8f] detecting whether an external object is proximate begins substantially concurrently with the mobile station initiating an outgoing wireless telephone call or receiving an incoming wireless telephone call.

Seo discloses that detecting whether an external object is proximate begins substantially concurrently with the mobile station initiating an outgoing wireless telephone call or receiving an incoming wireless telephone call.

For example: *see* discussion of claim element [1i], *supra*, which is incorporated herein by reference.

To the extent Seo is deemed to not expressly disclose this claim limitation, Seo inherently discloses this limitation. *See* discussion of claim element [1i], *supra*, which is incorporated herein by reference.

To the extent Seo is deemed to not expressly or inherently disclose this claim limitation, Seo renders it obvious to one of skill in the art at the time of the alleged invention. *See* discussion of claim element [1i], *supra*, which is incorporated herein by reference.

To the extent Seo is deemed to not expressly or inherently disclose this claim element, it would be obvious to combine the disclosure of Seo with those of Numazawa as described in the Numazawa claim chart, which is incorporated herein in its entirety by reference. *See* discussion of claim element [1i], *supra*, which is incorporated herein by reference.

To the extent Seo is deemed to not expressly or inherently disclose this claim element, it would be obvious to combine the disclosure of Seo with those of Fukiharu 598 as described in the Fukiharu 598 claim chart, which is incorporated herein in its entirety by reference. *See* discussion of claim element [1i], *supra*, which is incorporated herein by reference.

To the extent Seo is deemed to not expressly or inherently disclose this claim element, it would be obvious to combine the disclosure of Seo with those of Miyashita as described in the Miyashita claim chart, which is incorporated herein in its entirety by reference. *See* discussion of claim element [1i], *supra*, which is incorporated herein by reference.

<p>[Claim 12] The method as recited in claim 8, wherein the detecting of the proximity of the external object is performed by a mechanical proximity sensor, an optical sensor, or a range-detecting sensor.</p>	<p>Seo discloses that the detecting of the proximity of the external object is performed by a mechanical proximity sensor, an optical sensor, or a range-detecting sensor.</p> <p>For example: <i>see</i> discussion of claim 5, <i>supra</i>, which is incorporated herein by reference.</p> <p>To the extent Seo is deemed to not expressly disclose this claim limitation, Seo inherently discloses this limitation. <i>See</i> discussion of claim 5, <i>supra</i>, which is incorporated herein by reference.</p> <p>To the extent Seo is deemed to not expressly or inherently disclose this claim limitation, Seo renders it obvious to one of skill in the art at the time of the alleged invention. <i>See</i> discussion of claim 5, <i>supra</i>, which is incorporated herein by reference.</p>

Exhibit A5

**Exhibit #A5 - Perez
to Defendants' Preliminary Invalidity Contentions**

**Invalidity Chart for U.S. Patent No. 7,319,889
U.S. Patent Application Publication No. 2004/0225904A1 ("Perez")**

U.S. Patent Application Publication No. 2004/0225904A1 to Perez ("Perez") was filed on May 6, 2003 and was published on November 11, 2004. Perez is prior art to the '889 Patent under at least pre-AIA 35 U.S.C. § 102(e). Perez anticipates or renders obvious, alone or in combination with other prior art references, each of the Asserted Claims of the '889 Patent as described in the chart below and in the main invalidity contentions document to which this chart is annexed.

It would have been obvious under 35 U.S.C. § 103 to a person having ordinary skill in the art at the time of the alleged invention to combine the teachings of Perez with the following references:

1. Japanese Unexamined Patent Application Publication No. H11-220432 ("Numazawa"). Numazawa qualifies as prior art under at least pre-AIA §§ 102(a), 102(b), and 102(e). Numazawa was published on August 10, 1999.
2. Japanese Unexamined Patent Application Publication No. 2000-106598 to Fukiharu ("Fukiharu 598"). Fukiharu 598 qualifies as prior art under at least pre-AIA §§ 102(a), 102(b), and 102(e). Fukiharu 598 was published on April 11, 2000.
3. U.S. Patent No. 5,586,182 to Miyashita ("Miyashita"). Miyashita qualifies as prior art under at least pre-AIA 35 U.S.C. § 102(e). Miyashita was filed on May 1, 1995 and issued on December 17, 1996.

Asserted Claims	Corresponding Disclosure in the Prior Art Reference(s)
[Claim 1 – Preamble] 1. A mobile station, comprising:	<p>Perez discloses a mobile station.</p> <p>For example:</p> <p>“A portable communication product (10) such as a cellular phone includes a transceiver radio having a microphone (20), an earpiece (22), a keypad (18) and a display (12) coupled to the transceiver radio. The portable communication product further includes at least one sensor (24, 26, 28, or 30) and a processor (16). The sensor can be used for detecting a user condition of the portable communication device such as a talk condition when the user is assumed to be talking on the portable communication product. The processor can be programmed to at least reduce power provided to the display when the sensor detects the talk condition.” Perez at Abstract.</p>

“A method and apparatus for display power management in a portable communication device can provide additional battery savings to enable increased talk times and standby times without altering current battery technology. Embodiments in accordance with the present invention take advantage of actual usage patterns of users of portable phones to reduce current drain by displays and other illumination sources in cellular phones and other portable communication devices.” Perez at [0005].

“In a first aspect of the present invention, a portable communication device comprises a transceiver radio, a display coupled to the transceiver radio, a sensor and a processor. The sensor can be used for detecting a user condition of the portable communication device such as a talk condition when the user is assumed to be talking on the portable communication device. The processor can be programmed to at least reduce power provided to the display when the sensor detects the talk condition. The processor can also turn off power to the display during a talk condition if desired.” Perez at [0006].

“In a second aspect of the present invention, a portable communication device comprises a transceiver radio, a light source coupled to the transceiver radio, an environmental sensor and a processor. The environmental sensor can be used for detecting a user condition of the portable communication device such as a talk condition when the user is assumed to be talking on the portable communication device and the processor can be programmed to at least reduce power provided to the light source when the sensor detects the talk condition.” Perez at [0007].

“In a third aspect of the present invention, a method of power management for a radio communication device having a display comprises the steps of detecting a talking condition and at least reducing the power provided to the display within a predetermined time of the talking condition.” Perez at [0008]

“Referring to FIG. 1, a portable communication product **10** such as a cellular phone includes a transceiver radio having a microphone **20**, an earpiece **22**, a keypad **18** and a display **12** (such as a color display) coupled to the transceiver radio.” Perez at [0013].

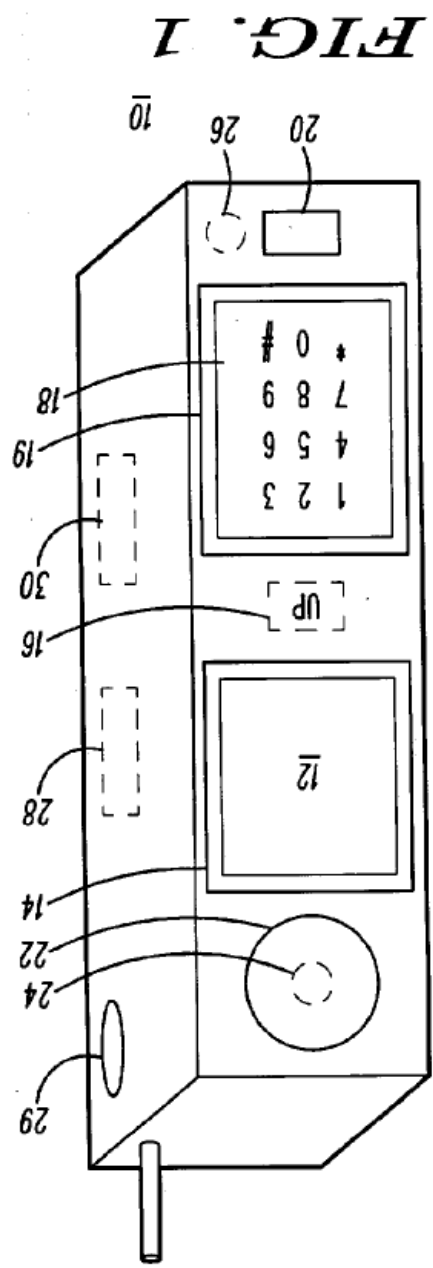

Perez at Fig. 1.

“1. A portable communication device, comprising:
 a transceiver radio;
 a display coupled to the transceiver radio;

	<p>a sensor for detecting a user condition of the portable communication device, wherein the user condition can comprise a talk condition when the user is assumed to be talking on the portable communication device; and</p> <p>a processor programmed to at least reduce power provided to the display when the sensor detects the talk condition.” Perez at Claim 1.</p>
<p>[1a] a display;</p>	<p>Perez discloses a display.</p> <p>For example:</p> <p>“A portable communication product (10) such as a cellular phone includes a transceiver radio having a microphone (20), an earpiece (22), a keypad (18) and a display (12) coupled to the transceiver radio. The portable communication product further includes at least one sensor (24, 26, 28, or 30) and a processor (16). The sensor can be used for detecting a user condition of the portable communication device such as a talk condition when the user is assumed to be talking on the portable communication product. The processor can be programmed to at least reduce power provided to the display when the sensor detects the talk condition.” Perez at Abstract.</p> <p>“A method and apparatus for display power management in a portable communication device can provide additional battery savings to enable increased talk times and standby times without altering current battery technology. Embodiments in accordance with the present invention take advantage of actual usage patterns of users of portable phones to reduce current drain by displays and other illumination sources in cellular phones and other portable communication devices.” Perez at [0005].</p> <p>“In a first aspect of the present invention, a portable communication device comprises a transceiver radio, a display coupled to the transceiver radio, a sensor and a processor. The sensor can be used for detecting a</p>

user condition of the portable communication device such as a talk condition when the user is assumed to be talking on the portable communication device. The processor can be programmed to at least reduce power provided to the display when the sensor detects the talk condition. The processor can also turn off power to the display during a talk condition if desired.” Perez at [0006].

“In a third aspect of the present invention, a method of power management for a radio communication device having a display comprises the steps of detecting a talking condition and at least reducing the power provided to the display within a predetermined time of the talking condition.” Perez at [0008].

“Referring to FIG. 1, a portable communication product **10** such as a cellular phone includes a transceiver radio having a microphone **20**, an earpiece **22**, a keypad **18** and a display **12** (such as a color display) coupled to the transceiver radio.” Perez at [0013].

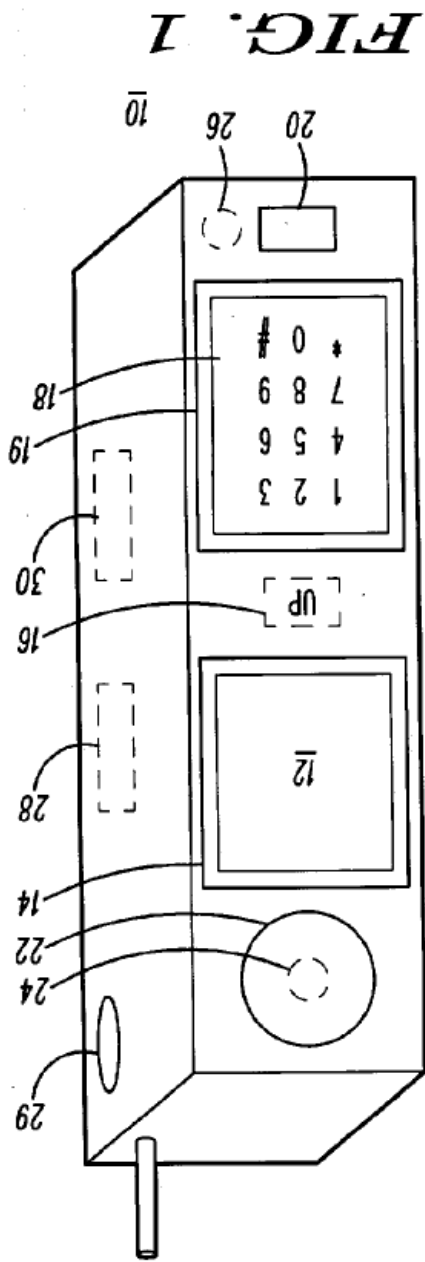

Perez at Fig. 1.

“1. A portable communication device, comprising:

a transceiver radio;

a display coupled to the transceiver radio;

a sensor for detecting a user condition of the portable communication device, wherein the user condition can comprise a talk condition when the user is assumed to be talking on the portable communication device; and

a processor programmed to at least reduce power provided to the display when the sensor detects the talk condition.” Perez at Claim 1.

	<p>“14. The portable communication device of claim 1, wherein the display is a color display.” Perez at Claim 14.</p>
<p>[1b] a proximity sensor adapted to generate a signal indicative of proximity of an external object; and</p>	<p>Perez discloses a proximity sensor adapted to generate a signal indicative of proximity of an external object.</p> <p>For example:</p> <p>“A portable communication product (10) such as a cellular phone includes a transceiver radio having a microphone (20), an earpiece (22), a keypad (18) and a display (12) coupled to the transceiver radio. The portable communication product further includes at least one sensor (24, 26, 28, or 30) and a processor (16). The sensor can be used for detecting a user condition of the portable communication device such as a talk condition when the user is assumed to be talking on the portable communication product. The processor can be programmed to at least reduce power provided to the display when the sensor detects the talk condition.” Perez at Abstract.</p> <p>“Referring to FIG. 1, a portable communication product 10 such as a cellular phone includes a transceiver radio having a microphone 20, an earpiece 22, a keypad 18 and a display 12 (such as a color display) coupled to the transceiver radio. The portable communication product 10 further includes at least one sensor (24, 26, 28 or 30) and a processor 16. The sensor can be used for detecting a user condition of the portable communication device such as a talk condition when the user is assumed to be talking on the portable communication device. The processor 16 can be programmed to at least reduce power provided to the display 12 when the sensor detects the talk condition. The processor 16 can also turn off power to the display 12 during a talk condition if desired.” Perez at [0013].</p>

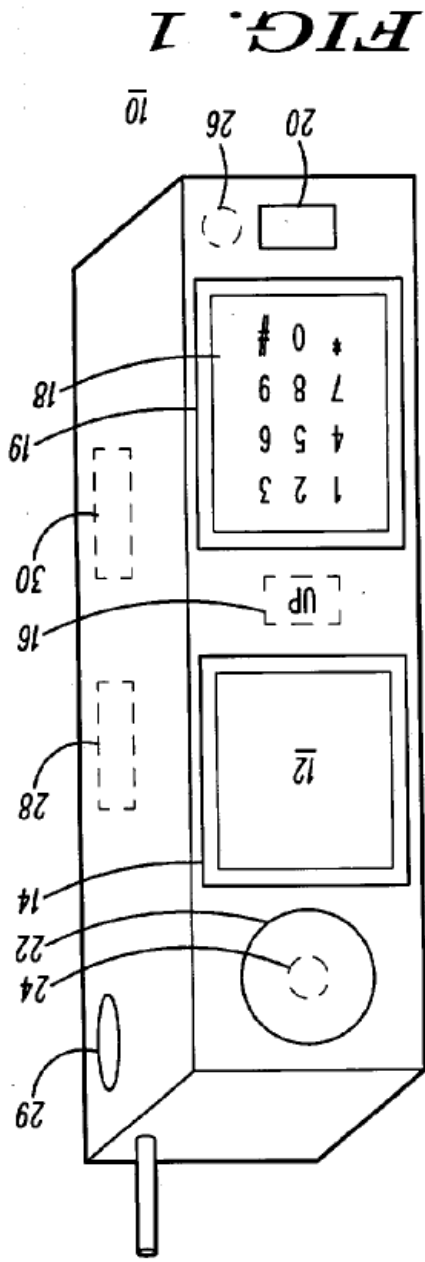

Perez at Fig. 1.

“A talk condition can be sensed in quite a number of ways. After the talk condition is detected or sensed, at least one or more among the display 12, the backlight 14 (for the display), or the backlight 19 (for the keypad) can be turned off or at least operate at a reduced power level. A talk condition, for example, can be sensed by detecting if a predetermined volume of acoustic sound is being received at the microphone 20 or at another sensor such as a proximity sensor 26 indicative of a user talking on the portable communication device. The sensors 20 or 26 can detect if a predetermined volume of acoustic sound is being received at either sensor. Alternatively, a talk condition can be sensed by measuring at least one among a spectrum density or a spectrum energy of a bounced signal to determine the proximity of a user's head to an earpiece of the portable communication device using a microphone or a proximity sensor 24 as further detailed with respect to FIG. 3. A talk condition can also be sensed by detecting an angle at which the portable communication device 10 is positioned or by detecting a vibration of the portable communication device 10. There is no need to keep the display 12 on if the phone is sitting idle. Ergonomically, a phone will be used at a certain predetermined angle-range anytime a phone call is active and the user is listening to the earpiece. A sensor 28 for sensing either the angle or a vibration of the portable communication device can be embodied

by a microelectronic mechanical systems (MEMS) device. Another way for sensing a talk condition can be achieved by sensing if the portable communication device 10 is in a user's hand. A sensor 30 can be a differential pressure sensor or a thermal sensor that indicates that the phone is in a user's hands. All the sensors described above should be considered environmental sensors with respect to the present invention.” Perez at [0015].

“In one particular embodiment as shown in FIG. 3, the sensor or sensors 100 can comprise the earpiece 22, the microphone 24, a coder/decoder 104 and a digital signal processor (DSP) 102. The sensor 100 can utilize an acoustic feedback algorithm that measures at least a spectrum density or a spectrum energy of a bounced signal to determine the proximity of a user's head to the earpiece 22 of the portable communication device. The sensor 100 can also be used to control the outbound audio quality or provide a constant audio level (from the perspective of the user) by automatically adjusting the audio level based on the proximity to the ear of the user. This automatic adjustment can additionally lower the power consumption by the audio coder/decoder 104.” Perez at [0019].

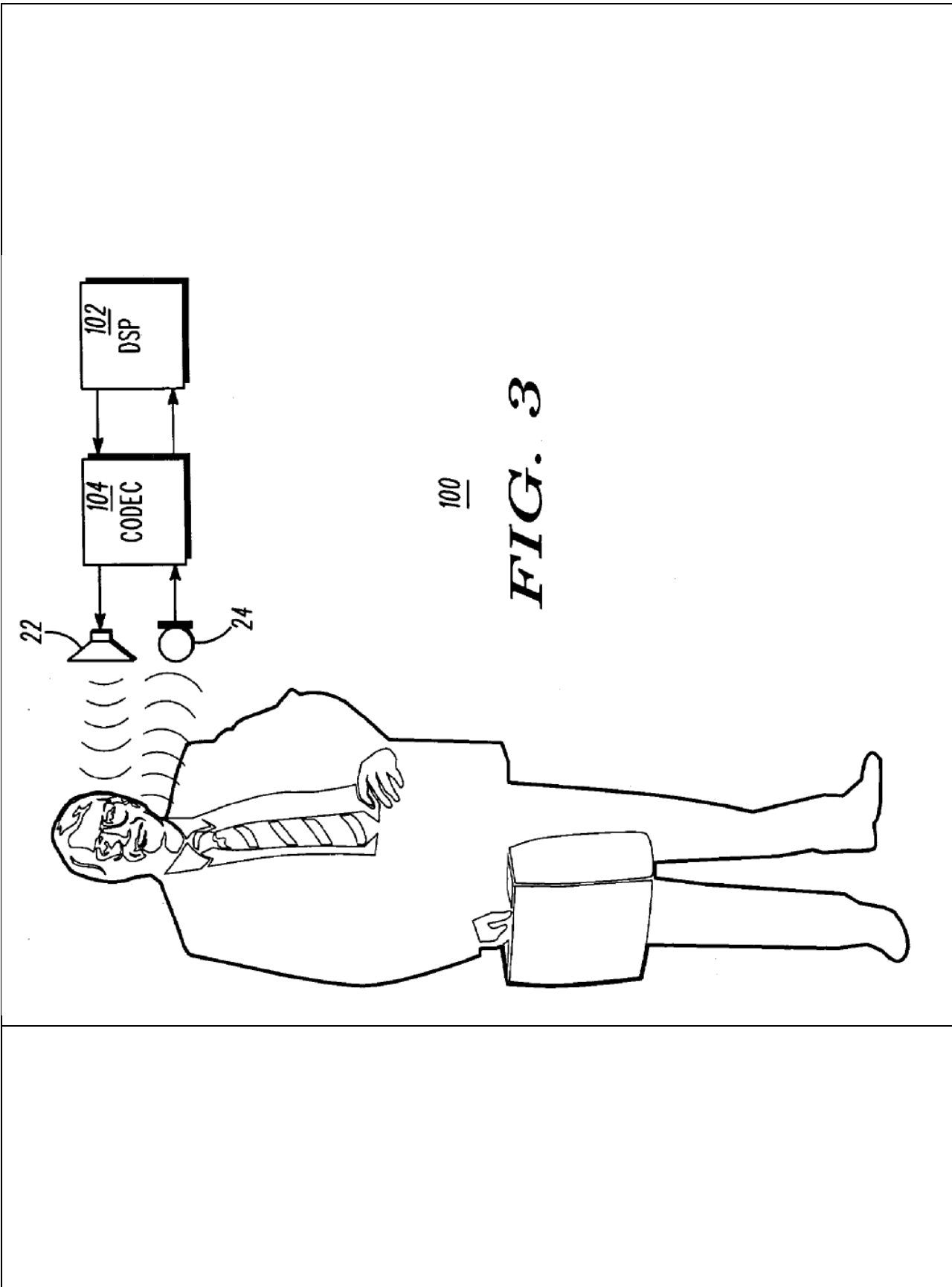

100
FIG. 3

	<p>Perez at Fig. 3.</p> <p>“5. The portable communication device of claim 1, wherein the sensor comprises a proximity sensor for detecting if a predetermined volume of acoustic sound is being received at a microphone indicative of a user talking on the portable communication device.” Perez at Claim 5.</p> <p>“6. The portable communication device of claim 1, wherein the sensor comprises an acoustic feedback algorithm that measures at least one among a spectrum density and a spectrum energy of a bounced signal to determine the proximity of a user's head to an earpiece of the portable communication device.” Perez at Claim 6.</p>
<p>[1c] a microprocessor adapted to:</p>	<p>Perez discloses a microprocessor.</p> <p>For example:</p> <p>“A portable communication product (10) such as a cellular phone includes a transceiver radio having a microphone (20), an earpiece (22), a keypad (18) and a display (12) coupled to the transceiver radio. The portable communication product further includes at least one sensor (24, 26, 28, or 30) and a processor (16). The sensor can be used for detecting a user condition of the portable communication device such as a talk condition when the user is assumed to be talking on the portable communication product. The processor can be programmed to at least reduce power provided to the display when the sensor detects the talk condition.” Perez at Abstract.</p> <p>“In a first aspect of the present invention, a portable communication device comprises a transceiver radio, a display coupled to the transceiver radio, a sensor and a processor. The sensor can be used for detecting a user condition of the portable communication device such as a talk condition when the user is assumed to be talking on the portable communication device. The processor can be programmed to at least reduce</p>

power provided to the display when the sensor detects the talk condition. The processor can also turn off power to the display during a talk condition if desired.” Perez at [0006].

“In a second aspect of the present invention, a portable communication device comprises a transceiver radio, a light source coupled to the transceiver radio, an environmental sensor and a processor. The environmental sensor can be used for detecting a user condition of the portable communication device such as a talk condition when the user is assumed to be talking on the portable communication device and the processor can be programmed to at least reduce power provided to the light source when the sensor detects the talk condition.” Perez at [0007].

“Referring to FIG. 1, a portable communication product **10** such as a cellular phone includes a transceiver radio having a microphone **20**, an earpiece **22**, a keypad **18** and a display **12** (such as a color display) coupled to the transceiver radio. The portable communication product **10** further includes at least one sensor (**24**, **26**, **28** or **30**) and a processor **16**. The sensor can be used for detecting a user condition of the portable communication device such as a talk condition when the user is assumed to be talking on the portable communication device. The processor **16** can be programmed to at least reduce power provided to the display **12** when the sensor detects the talk condition. The processor **16** can also turn off power to the display **12** during a talk condition if desired.” Perez at [0013].

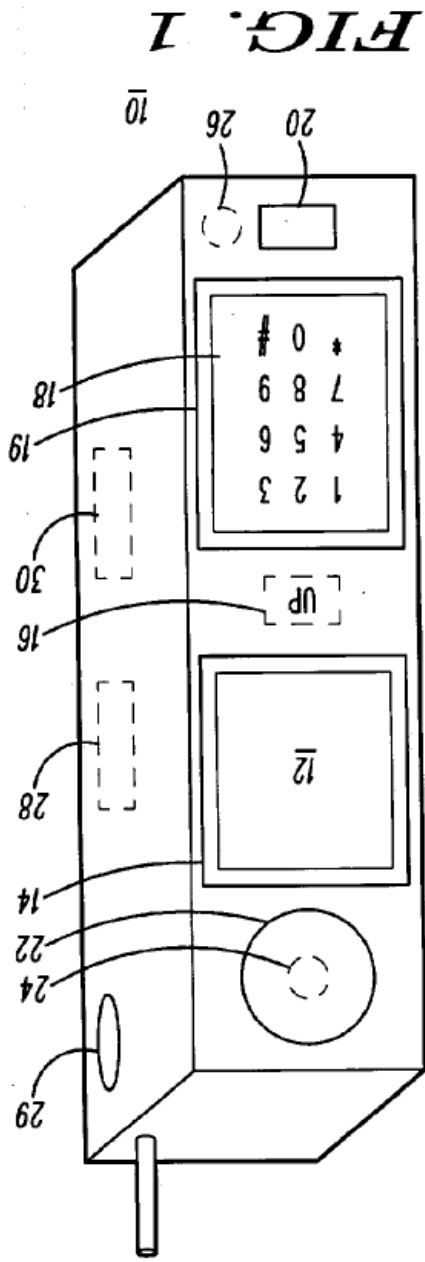

Perez at Fig. 1.

“In light of the foregoing description of the invention, it should be recognized that the present invention can be realized in hardware, software, or a combination of hardware and software. A method and system for power management in a communication device according to the present invention can be realized in a centralized fashion in one computer system or processor, or in a distributed fashion where different elements are spread across several interconnected computer systems or processors (such as a microprocessor and a DSP). Any kind of computer system, or other apparatus adapted for carrying out the methods described herein, is suited. A typical combination of hardware and software could be a general purpose computer system with a computer program that, when being loaded and executed, controls the computer system such that it carries out the methods described herein.” Perez at [0023].

“1. A portable communication device, comprising:

	<p>a transceiver radio; a display coupled to the transceiver radio; a sensor for detecting a user condition of the portable communication device, wherein the user condition can comprise a talk condition when the user is assumed to be talking on the portable communication device; and a processor programmed to at least reduce power provided to the display when the sensor detects the talk condition.” Perez at Claim 1.</p>
<p>[1d] (a) determine whether a telephone call is active;</p>	<p>Perez discloses the microprocessor adapted to determine whether a telephone call is active.</p> <p>For example:</p> <p>“A portable communication product (10) such as a cellular phone includes a transceiver radio having a microphone (20), an earpiece (22), a keypad (18) and a display (12) coupled to the transceiver radio. The portable communication product further includes at least one sensor (24, 26, 28, or 30) and a processor (16). The sensor can be used for detecting a user condition of the portable communication device such as a talk condition when the user is assumed to be talking on the portable communication product. The processor can be programmed to at least reduce power provided to the display when the sensor detects the talk condition.” Perez at Abstract.</p> <p>“In a first aspect of the present invention, a portable communication device comprises a transceiver radio, a display coupled to the transceiver radio, a sensor and a processor. The sensor can be used for detecting a user condition of the portable communication device such as a talk condition when the user is assumed to be talking on the portable communication device. The processor can be programmed to at least reduce</p>

power provided to the display when the sensor detects the talk condition. The processor can also turn off power to the display during a talk condition if desired.” Perez at [0006].

“In a second aspect of the present invention, a portable communication device comprises a transceiver radio, a light source coupled to the transceiver radio, an environmental sensor and a processor. The environmental sensor can be used for detecting a user condition of the portable communication device such as a talk condition when the user is assumed to be talking on the portable communication device and the processor can be programmed to at least reduce power provided to the light source when the sensor detects the talk condition.” Perez at [0007].

“In a third aspect of the present invention, a method of power management for a radio communication device having a display comprises the steps of detecting a talking condition and at least reducing the power provided to the display within a predetermined time of the talking condition.” Perez at [0008]

“The step of detecting a talk condition can be selected from the group of conditions consisting of a) detecting if a predetermined volume of acoustic sound is being received at a microphone indicative of a user talking on the portable communication device; b) measuring at least one among a spectrum density and a spectrum energy of a bounced signal to determine the proximity of a user's head to an earpiece of the portable communication device; c) measuring a predetermined period after a phone call starts; d) detecting an angle at which the portable communication device is positioned; e) detecting a vibration of the portable communication device; and f) detecting if the portable communication device is in a user's hand.” Perez at [0009].

“Referring to FIG. 1, a portable communication product **10** such as a cellular phone includes a transceiver radio having a microphone **20**, an earpiece **22**, a keypad **18** and a display **12** (such as a color display) coupled to the transceiver radio. The portable communication product **10** further includes at least one sensor (**24**, **26**, **28** or **30**) and a processor **16**. The sensor can be used for detecting a user condition of the portable

communication device such as a talk condition when the user is assumed to be talking on the portable communication device. The processor 16 can be programmed to at least reduce power provided to the display 12 when the sensor detects the talk condition. The processor 16 can also turn off power to the display 12 during a talk condition if desired.” Perez at [0013].

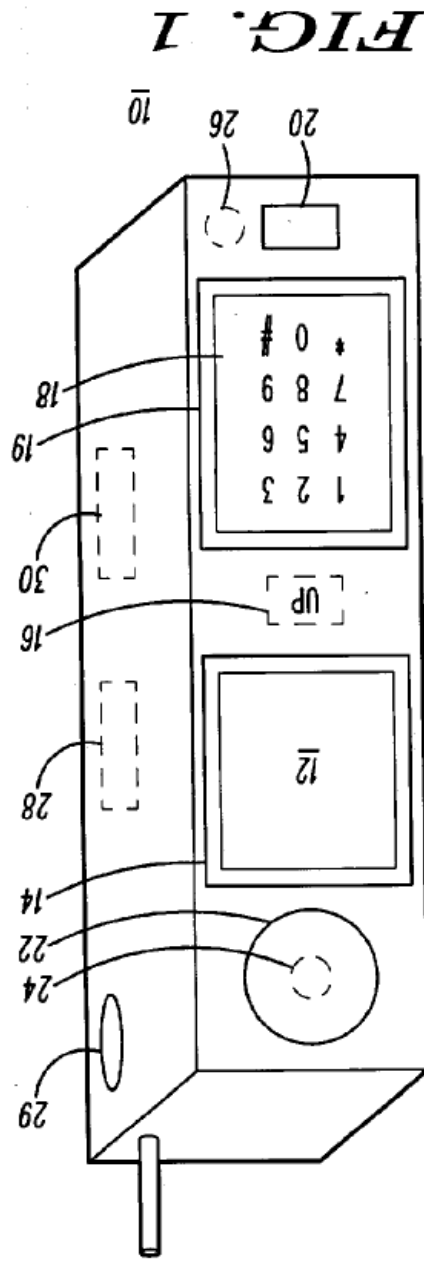

Perez at Fig. 1.

“In one embodiment, the portable communication device 10 can also include other illumination or lighting devices. For example, the display 12 can have backlighting 14 and/or the keypads can have backlighting 19 as is well known in the industry. Although backlighting provides great ergonomic benefits to a user in visually reading a display or keypad, the additional current drain on a battery can significantly reduce overall talk time. Thus, to overcome this disadvantage, the present invention accounts for actual usage by a user by sensing a talk condition. A talk condition should generally be understood as the condition when a user is on an active call and speaking into the microphone 20 or listening to the earpiece 22. A light

source in the portable communication device **10** should also be understood as being either the display device itself, a light source for backlighting the display device, and a light source for backlighting the keypad of the portable communication device. Of course, other illumination devices that can be used in a portable communication are contemplated within the present invention.” Perez at [0014].

“A talk condition can be sensed in quite a number of ways. After the talk condition is detected or sensed, at least one or more among the display **12**, the backlight **14** (for the display), or the backlight **19** (for the keypad) can be turned off or at least operate at a reduced power level. A talk condition, for example, can be sensed by detecting if a predetermined volume of acoustic sound is being received at the microphone **20** or at another sensor such as a proximity sensor **26** indicative of a user talking on the portable communication device. The sensors **20** or **26** can detect if a predetermined volume of acoustic sound is being received at either sensor. Alternatively, a talk condition can be sensed by measuring at least one among a spectrum density or a spectrum energy of a bounced signal to determine the proximity of a user's head to an earpiece of the portable communication device using a microphone or a proximity sensor **24** as further detailed with respect to FIG. 3. A talk condition can also be sensed by detecting an angle at which the portable communication device **10** is positioned or by detecting a vibration of the portable communication device **10**. There is no need to keep the display **12** on if the phone is sitting idle. Ergonomically, a phone will be used at a certain predetermined angle-range anytime a phone call is active and the user is listening to the earpiece. A sensor **28** for sensing either the angle or a vibration of the portable communication device can be embodied by a microelectronic mechanical systems (MEMS) device. Another way for sensing a talk condition can be achieved by sensing if the portable communication device **10** is in a user's hand. A sensor **30** can be a differential pressure sensor or a thermal sensor that indicates that the phone is in a user's hands. All the sensors described above should be considered environmental sensors with respect to the present invention.” Perez at [0015].

“In yet another alternative, sensing a talk condition can involve simply measuring a predetermined period after a phone call starts. The predetermined time period can be user selectable and can be programmed using the processor **16** as a timer. After the phone call starts and upon expiration of the predetermined period, the processor **16** can be programmed to shut off or reduce power to the display **12** or other illumination sources in the portable communication device **10**.” Perez at [0016].

	<p>“As mentioned previously, the step of detecting a talk condition can be achieved by monitoring or detecting at least one among the conditions of a) detecting if a predetermined volume of acoustic sound is being received at a microphone indicative of a user talking on the portable communication device; b) measuring at least one among a spectrum density and a spectrum energy of a bounced signal to determine the proximity of a user's head to an earpiece of the portable communication device; c) measuring a predetermined period after a phone call starts; d) detecting an angle at which the portable communication device is positioned; e) detecting a vibration of the portable communication device; or f) detecting if the portable communication device is in a user's hand. How the method 50 can detect the conditions described above can be embodied in many different forms using individually or in combination sensors and timers and other devices.” Perez at [0022].</p>
<p>[1c] (b) receive the signal from the proximity sensor; and</p>	<p>Perez discloses the microprocessor adapted to receive the signal from the proximity sensor.</p> <p>For example: <i>see</i> discussion of claim element [1b], <i>supra</i>, which is incorporated herein by reference.</p> <p>“The sensor can be used for detecting a user condition of the portable communication device such as a talk condition when the user is assumed to be talking on the portable communication product. The processor can be programmed to at least reduce power provided to the display when the sensor detects the talk condition.” Perez at Abstract.</p> <p>“In a first aspect of the present invention, a portable communication device comprises a transceiver radio, a display coupled to the transceiver radio, a sensor and a processor. The sensor can be used for detecting a user condition of the portable communication device such as a talk condition when the user is assumed to be talking on the portable communication device. The processor can be programmed to at least reduce power provided to the display when the sensor detects the talk condition. The processor can also turn off power to the display during a talk condition if desired.” Perez at [0006].</p>

“In a second aspect of the present invention, a portable communication device comprises a transceiver radio, a light source coupled to the transceiver radio, an environmental sensor and a processor. The environmental sensor can be used for detecting a user condition of the portable communication device such as a talk condition when the user is assumed to be talking on the portable communication device and the processor can be programmed to at least reduce power provided to the light source when the sensor detects the talk condition.” Perez at [0007].

FIG. 3 is a block diagram of a digital signal processor and coder/decoder used as a sensor for acoustic feedback for determining proximity in accordance with the present invention. Perez at [0012].

“Referring to FIG. 1, a portable communication product **10** such as a cellular phone includes a transceiver radio having a microphone **20**, an earpiece **22**, a keypad **18** and a display **12** (such as a color display) coupled to the transceiver radio. The portable communication product **10** further includes at least one sensor (24, 26, 28 or 30) and a processor **16**. The sensor can be used for detecting a user condition of the portable communication device such as a talk condition when the user is assumed to be talking on the portable communication device. The processor **16** can be programmed to at least reduce power provided to the display **12** when the sensor detects the talk condition. The processor **16** can also turn off power to the display **12** during a talk condition if desired.” Perez at [0013].

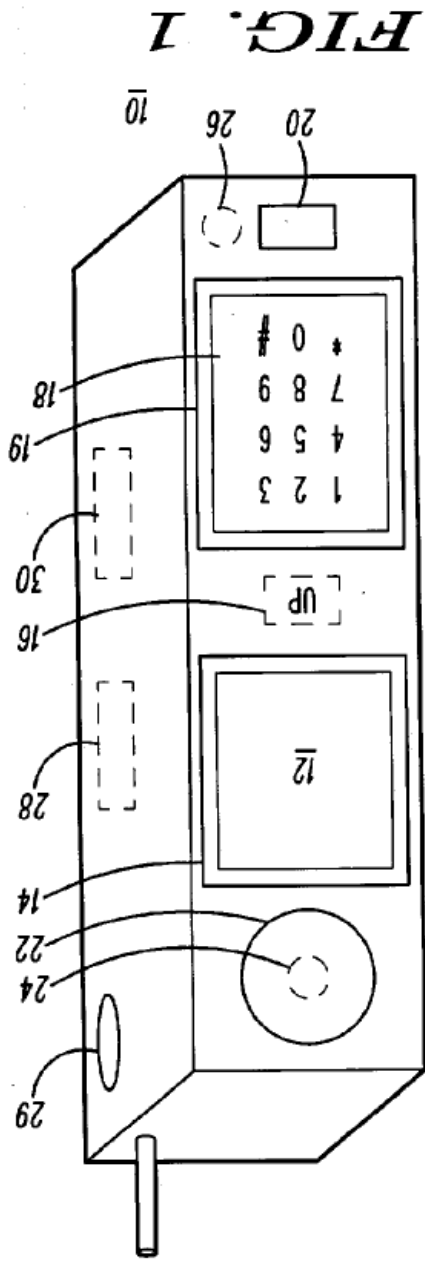

Perez at Fig. 1.

“A talk condition, for example, can be sensed by detecting if a predetermined volume of acoustic sound is being received at the microphone 20 or at another sensor such as a proximity sensor 26 indicative of a user talking on the portable communication device. The sensors 20 or 26 can detect if a predetermined volume of acoustic sound is being received at either sensor. Alternatively, a talk condition can be sensed by measuring at least one among a spectrum density or a spectrum energy of a bounced signal to determine the proximity of a user's head to an earpiece of the portable communication device using a microphone or a proximity sensor 24 as further detailed with respect to FIG. 3 Another way for sensing a talk condition can be achieved by sensing if the portable communication device 10 is in a user's hand. A sensor 30 can be a differential pressure sensor or a thermal sensor that indicates that the phone is in a user's hands. All the sensors described above should be considered environmental sensors with respect to the present invention.”
Perez at [0015].

“In one particular embodiment as shown in FIG. 3, the sensor or sensors 100 can comprise the earpiece 22, the microphone 24, a coder/decoder 104 and a digital signal processor (DSP) 102. The sensor 100 can utilize an acoustic feedback algorithm that measures at least a spectrum density or a spectrum energy of a bounced signal to determine the proximity of a user's head to the earpiece 22 of the portable communication device. The sensor 100 can also be used to control the outbound audio quality or provide a constant audio level (from the perspective of the user) by automatically adjusting the audio level based on the proximity to the ear of the user. This automatic adjustment can additionally lower the power consumption by the audio coder/decoder 104.” Perez at [0019].

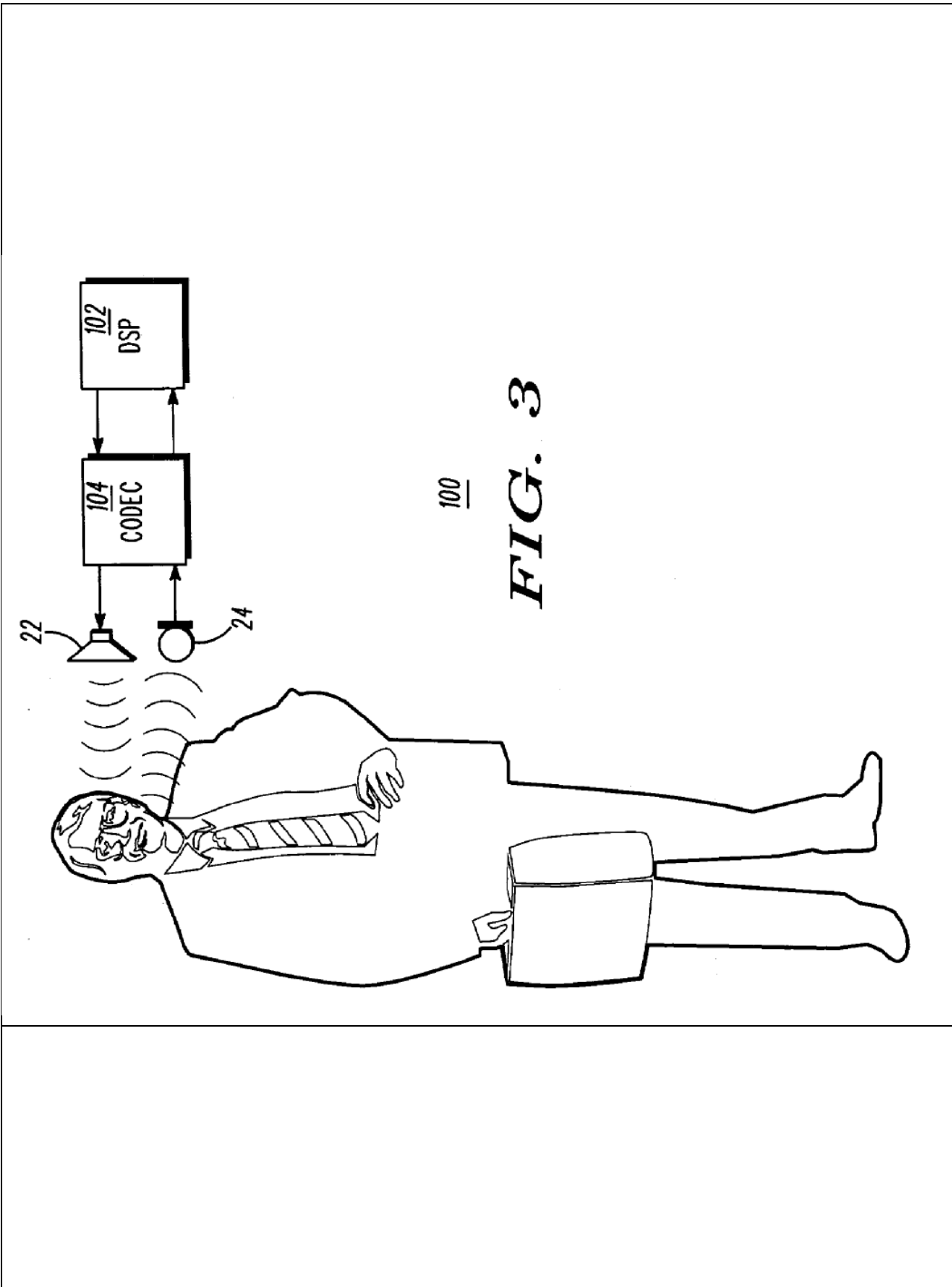

100
FIG. 3

	<p>Perez at Fig. 3.</p> <p>“1. A portable communication device, comprising: a transceiver radio; a display coupled to the transceiver radio; a sensor for detecting a user condition of the portable communication device, wherein the user condition can comprise a talk condition when the user is assumed to be talking on the portable communication device; and a processor programmed to at least reduce power provided to the display when the sensor detects the talk condition.” Perez at Claim 1.</p>
<p>[1f] (c) reduce power to the display if (i) the microprocessor determines that a telephone call is active and (ii) the signal indicates the proximity of the external object; wherein:</p>	<p>Perez discloses the microprocessor adapted to reduce power to the display if (i) the microprocessor determines that a telephone call is active and (ii) the signal indicates the proximity of the external object.</p> <p>For example: <i>see</i> discussions of claim elements [1b], [1d], [1e], [1e], <i>supra</i>, which are incorporated herein by reference.</p> <p>“A portable communication product (10) such as a cellular phone includes a transceiver radio having a microphone (20), an earpiece (22), a keypad (18) and a display (12) coupled to the transceiver radio. The portable communication product further includes at least one sensor (24, 26, 28, or 30) and a processor (16). The sensor can be used for detecting a user condition of the portable communication device such as a talk condition when the user is assumed to be talking on the portable communication product. The processor</p>

can be programmed to at least reduce power provided to the display when the sensor detects the talk condition.” Perez at Abstract.

“A method and apparatus for display power management in a portable communication device can provide additional battery savings to enable increased talk times and standby times without altering current battery technology. Embodiments in accordance with the present invention take advantage of actual usage patterns of users of portable phones to reduce current drain by displays and other illumination sources in cellular phones and other portable communication devices.” Perez at [0005].

“In a first aspect of the present invention, a portable communication device comprises a transceiver radio, a display coupled to the transceiver radio, a sensor and a processor. The sensor can be used for detecting a user condition of the portable communication device such as a talk condition when the user is assumed to be talking on the portable communication device. The processor can be programmed to at least reduce power provided to the display when the sensor detects the talk condition. The processor can also turn off power to the display during a talk condition if desired.” Perez at [0006].

“In a second aspect of the present invention, a portable communication device comprises a transceiver radio, a light source coupled to the transceiver radio, an environmental sensor and a processor. The environmental sensor can be used for detecting a user condition of the portable communication device such as a talk condition when the user is assumed to be talking on the portable communication device and the processor can be programmed to at least reduce power provided to the light source when the sensor detects the talk condition.” Perez at [0007].

“In a third aspect of the present invention, a method of power management for a radio communication device having a display comprises the steps of detecting a talking condition and at least reducing the power provided to the display within a predetermined time of the talking condition.” Perez at [0008]

“The step of detecting a talk condition can be selected from the group of conditions consisting of a) detecting if a predetermined volume of acoustic sound is being received at a microphone indicative of a user talking on the portable communication device; b) measuring at least one among a spectrum density and a spectrum energy of a bounced signal to determine the proximity of a user's head to an earpiece of the portable communication device; c) measuring a predetermined period after a phone call starts; d) detecting an angle at which the portable communication device is positioned; e) detecting a vibration of the portable communication device; and f) detecting if the portable communication device is in a user's hand.” Perez at [0009].

“Referring to FIG. 1, a portable communication product **10** such as a cellular phone includes a transceiver radio having a microphone **20**, an earpiece **22**, a keypad **18** and a display **12** (such as a color display) coupled to the transceiver radio. The portable communication product **10** further includes at least one sensor (**24**, **26**, **28** or **30**) and a processor **16**. The sensor can be used for detecting a user condition of the portable communication device such as a talk condition when the user is assumed to be talking on the portable communication device. The processor **16** can be programmed to at least reduce power provided to the display **12** when the sensor detects the talk condition. The processor **16** can also turn off power to the display **12** during a talk condition if desired.” Perez at [0013].

“In one embodiment, the portable communication device **10** can also include other illumination or lighting devices. For example, the display **12** can have backlighting **14** and/or the keypads can have backlighting **19** as is well known in the industry. Although backlighting provides great ergonomic benefits to a user in visually reading a display or keypad, the additional current drain on a battery can significantly reduce overall talk time. Thus, to overcome this disadvantage, the present invention accounts for actual usage by a user by sensing a talk condition. A talk condition should generally be understood as the condition when a user is on an active call and speaking into the microphone **20** or listening to the earpiece **22**. A light source in the portable communication device **10** should also be understood as being either the display device itself, a light source for backlighting the display device, and a light source for backlighting the keypad of the

portable communication device. Of course, other illumination devices that can be used in a portable communication are contemplated within the present invention.” Perez at [0014].

“A talk condition can be sensed in quite a number of ways. After the talk condition is detected or sensed, at least one or more among the display **12**, the backlight **14** (for the display), or the backlight **19** (for the keypad) can be turned off or at least operate at a reduced power level. A talk condition, for example, can be sensed by detecting if a predetermined volume of acoustic sound is being received at the microphone **20** or at another sensor such as a proximity sensor **26** indicative of a user talking on the portable communication device. The sensors **20** or **26** can detect if a predetermined volume of acoustic sound is being received at either sensor. Alternatively, a talk condition can be sensed by measuring at least one among a spectrum density or a spectrum energy of a bounced signal to determine the proximity of a user's head to an earpiece of the portable communication device using a microphone or a proximity sensor **24** as further detailed with respect to FIG. 3. A talk condition can also be sensed by detecting an angle at which the portable communication device **10** is positioned or by detecting a vibration of the portable communication device **10**. There is no need to keep the display **12** on if the phone is sitting idle. Ergonomically, a phone will be used at a certain predetermined angle-range anytime a phone call is active and the user is listening to the earpiece. A sensor **28** for sensing either the angle or a vibration of the portable communication device can be embodied by a microelectronic mechanical systems (MEMS) device. Another way for sensing a talk condition can be achieved by sensing if the portable communication device **10** is in a user's hand. A sensor **30** can be a differential pressure sensor or a thermal sensor that indicates that the phone is in a user's hands. All the sensors described above should be considered environmental sensors with respect to the present invention.” Perez at [0015].

“In yet another alternative, sensing a talk condition can involve simply measuring a predetermined period after a phone call starts. The predetermined time period can be user selectable and can be programmed using the processor **16** as a timer. After the phone call starts and upon expiration of the predetermined period, the processor **16** can be programmed to shut off or reduce power to the display **12** or other illumination sources in the portable communication device **10**.” Perez at [0016].

“Using the sensors **20, 22, 24, 26, 28** or **30** in combination with the processor **16**, the portable communication device **10** can turn off or reduce the power provided to at least one among the display **12**, the backlight **14**, or a light source (**19**) for the backlit keypad **18** when the portable communication device **10** is in a talk condition. Power for the light sources can be reduced or turned off either immediately upon detection of a talk condition or within a predetermined time as may be programmed into the portable communication device **10**. The shorter the predetermined time period, the more power that will likely be saved. The predetermined time period can be one (1) second for example. As mentioned above, the present invention takes account of actual user behavior and eliminates wasteful power consumption during periods when a user would normally not be looking at his or her display or keypad.” Perez at [0018].

“As mentioned previously, the step of detecting a talk condition can be achieved by monitoring or detecting at least one among the conditions of a) detecting if a predetermined volume of acoustic sound is being received at a microphone indicative of a user talking on the portable communication device; b) measuring at least one among a spectrum density and a spectrum energy of a bounced signal to determine the proximity of a user's head to an earpiece of the portable communication device; c) measuring a predetermined period after a phone call starts; d) detecting an angle at which the portable communication device is positioned; e) detecting a vibration of the portable communication device; or f) detecting if the portable communication device is in a user's hand. How the method **50** can detect the conditions described above can be embodied in many different forms using individually or in combination sensors and timers and other devices.” Perez at [0022].

“1. A portable communication device, comprising:

a transceiver radio;

a display coupled to the transceiver radio;

a sensor for detecting a user condition of the portable communication device, wherein the user condition can comprise a talk condition when the user is assumed to be talking on the portable communication device; and

a processor programmed to at least reduce power provided to the display when the sensor detects the talk condition.” Perez at Claim 1.

“5. The portable communication device of claim 1, wherein the sensor comprises a proximity sensor for detecting if a predetermined volume of acoustic sound is being received at a microphone indicative of a user talking on the portable communication device.” Perez at Claim 5.

“6. The portable communication device of claim 1, wherein the sensor comprises an acoustic feedback algorithm that measures at least one among a spectrum density and a spectrum energy of a bounced signal to determine the proximity of a user's head to an earpiece of the portable communication device.” Perez at Claim 6.

“18. A method of power management for a radio communication device having a display, comprising the steps of:

detecting a talk condition;

at least reducing the power provided to the display within a predetermined time of the talk condition.” Perez at Claim 18.

“20. The method of claim 18, wherein the step of detecting a talk condition is selected from the group of conditions consisting of a) detecting if a predetermined volume of acoustic sound is being received at a microphone indicative of a user talking on the portable communication device; b) measuring at least one among a spectrum density and a spectrum energy of a bounced signal to determine the proximity of a user's head to an earpiece of the portable communication device; c) measuring a predetermined period after a phone call starts; d) detecting an angle at which the portable communication device is positioned; e)

	<p>detecting a vibration of the portable communication device; and f) detecting if the portable communication device is in a user's hand.” Perez at Claim 20.</p> <p>To the extent Perez is deemed to not expressly disclose this claim limitation, Perez inherently discloses this limitation. <i>See</i> discussion of claim element [1h], <i>infra</i>, which is incorporated herein by reference.</p> <p>To the extent Perez is deemed to not expressly or inherently disclose this claim limitation, Perez renders it obvious to one of skill in the art at the time of the alleged invention. <i>See</i> discussion of claim element [1h], <i>infra</i>, which is incorporated herein by reference.</p> <p>To the extent Perez is deemed to not expressly or inherently disclose this claim element, it would be obvious to combine the disclosure of Perez with those of Fukiharu 598 as described in the Fukiharu 598 claim chart, which is incorporated herein in its entirety by reference. <i>See</i> discussion of claim element [1h], <i>infra</i>, which is incorporated herein by reference.</p> <p>To the extent Perez is deemed to not expressly or inherently disclose this claim element, it would be obvious to combine the disclosure of Perez with those of Numazawa as described in the Numazawa claim chart, which is incorporated herein in its entirety by reference. <i>See</i> discussion of claim element [1h], <i>infra</i>, which is incorporated herein by reference.</p> <p>To the extent Perez is deemed to not expressly or inherently disclose this claim element, it would be obvious to combine the disclosure of Perez with those of Miyashita as described in the Miyashita claim chart, which is incorporated herein in its entirety by reference. <i>See</i> discussion of claim element [1h], <i>infra</i>, which is incorporated herein by reference.</p>
<p>[1g] the telephone call is a wireless telephone call;</p>	<p>Perez discloses the telephone call as a wireless telephone call.</p> <p>For example: <i>see</i> discussions of claim elements [1a] and [1d], <i>supra</i>, which are incorporated herein by reference.</p>

“Power management in portable communication devices is an ever-present issue now being further exacerbated by the popular introduction and use of larger color displays with white LED backlights. User talk times are significantly affected because most of these large color displays remain on during phone calls. Existing phones fail to take advantage of some patterns exhibited by handset users as a means to reduce current drain. A typical user averaging a three (3) minute phone call will perceive a noticeable reduction in talk time due to the fact that both a backlight and a display remain on while the call is active. Some phones also include backlit keypads that remain illuminated as well during an active call.” Perez at [0003].

“Portable phones generally keep their display on at all times during a call while the backlight is typically turned off after 30 seconds of no key-activity (user selectable). The 30 seconds that the backlight remains on combined with a display that is not turned off during a phone call substantially affects the talk times based on the actual usage pattern. In some phones, this method may not be sufficiently efficient enough because it may leave the backlight turned on (using 40-60 mA) up to a significant percentage of each phone call time. With displays and illumination mechanisms in portable communication products increasingly vying for additional power from a portable battery, existing methods fail to provide adequate talk and standby times demanded by consumers.” Perez at [0004].

“1. A portable communication device, comprising:

a transceiver radio;

a display coupled to the transceiver radio;

a sensor for detecting a user condition of the portable communication device, wherein the user condition can comprise a talk condition when the user is assumed to be talking on the portable communication device; and

a processor programmed to at least reduce power provided to the display when the sensor detects the talk condition.” Perez at Claim 1.

	<p>“9. The portable communication device of claim 1, wherein the sensor comprises a timer for measuring a predetermined period after a phone call starts and upon expiration of the predetermined period the processor is further programmed to shut off the display.” Perez at Claim 9.</p>
<p>[1h] the microprocessor reduces power to the display while the signal indicates the proximity of the external object only if the microprocessor determines that the wireless telephone call is active; and</p>	<p>Perez discloses that the microprocessor reduces power to the display while the signal indicates the proximity of the external object only if the microprocessor determines that the wireless telephone call is active.</p> <p>For example: <i>see</i> discussion of claim element [1f], <i>supra</i>, which is incorporated herein by reference.</p> <p>The step of detecting a talk condition can be selected from the group of conditions consisting of a) detecting if a predetermined volume of acoustic sound is being received at a microphone indicative of a user talking on the portable communication device; b) measuring at least one among a spectrum density and a spectrum energy of a bounced signal to determine the proximity of a user's head to an earpiece of the portable communication device; c) measuring a predetermined period after a phone call starts; d) detecting an angle at which the portable communication device is positioned; e) detecting a vibration of the portable communication device; and f) detecting if the portable communication device is in a user's hand. Perez at [0019].</p> <p>“In one embodiment, the portable communication device 10 can also include other illumination or lighting devices. For example, the display 12 can have backlighting 14 and/or the keypads can have backlighting 19 as is well known in the industry. Although backlighting provides great ergonomic benefits to a user in visually reading a display or keypad, the additional current drain on a battery can significantly reduce overall talk time. Thus, to overcome this disadvantage, the present invention accounts for actual usage by a user by sensing a talk condition. A talk condition should generally be understood as the condition when a user is on an active call and speaking into the microphone 20 or listening to the earpiece 22. A light source in the portable communication device 10 should also be understood as being either the display device</p>

itself, a light source for backlighting the display device, and a light source for backlighting the keypad of the portable communication device. Of course, other illumination devices that can be used in a portable communication are contemplated within the present invention.” Perez at [0014].

“A talk condition can be sensed in quite a number of ways. After the talk condition is detected or sensed, at least one or more among the display **12**, the backlight **14** (for the display), or the backlight **19** (for the keypad) can be turned off or at least operate at a reduced power level. A talk condition, for example, can be sensed by detecting if a predetermined volume of acoustic sound is being received at the microphone **20** or at another sensor such as a proximity sensor **26** indicative of a user talking on the portable communication device. The sensors **20** or **26** can detect if a predetermined volume of acoustic sound is being received at either sensor. Alternatively, a talk condition can be sensed by measuring at least one among a spectrum density or a spectrum energy of a bounced signal to determine the proximity of a user's head to an earpiece of the portable communication device using a microphone or a proximity sensor **24** as further detailed with respect to FIG. 3. A talk condition can also be sensed by detecting an angle at which the portable communication device **10** is positioned or by detecting a vibration of the portable communication device **10**. There is no need to keep the display **12** on if the phone is sitting idle. Ergonomically, a phone will be used at a certain predetermined angle-range anytime a phone call is active and the user is listening to the earpiece. A sensor **28** for sensing either the angle or a vibration of the portable communication device can be embodied by a microelectronic mechanical systems (MEMS) device. Another way for sensing a talk condition can be achieved by sensing if the portable communication device **10** is in a user's hand. A sensor **30** can be a differential pressure sensor or a thermal sensor that indicates that the phone is in a user's hands. All the sensors described above should be considered environmental sensors with respect to the present invention.” Perez at [0015].

“In yet another alternative, sensing a talk condition can involve simply measuring a predetermined period after a phone call starts. The predetermined time period can be user selectable and can be programmed using the processor **16** as a timer. After the phone call starts and upon expiration of the predetermined period, the processor **16** can be programmed to shut off or reduce power to the display **12** or other illumination sources in the portable communication device **10**.” Perez at [0016].

“Using the sensors **20**, **22**, **24**, **26**, **28** or **30** in combination with the processor **16**, the portable communication device **10** can turn off or reduce the power provided to at least one among the display **12**, the backlight **14**, or a light source (**19**) for the backlit keypad **18** when the portable communication device **10** is in a talk condition. Power for the light sources can be reduced or turned off either immediately upon detection of a talk condition or within a predetermined time as may be programmed into the portable communication device **10**. The shorter the predetermined time period, the more power that will likely be saved. The predetermined time period can be one (1) second for example. As mentioned above, the present invention takes account of actual user behavior and eliminates wasteful power consumption during periods when a user would normally not be looking at his or her display or keypad.” Perez at [0018].

“As mentioned previously, the step of detecting a talk condition can be achieved by monitoring or detecting at least one among the conditions of a) detecting if a predetermined volume of acoustic sound is being received at a microphone indicative of a user talking on the portable communication device; b) measuring at least one among a spectrum density and a spectrum energy of a bounced signal to determine the proximity of a user's head to an earpiece of the portable communication device; c) measuring a predetermined period after a phone call starts; d) detecting an angle at which the portable communication device is positioned; e) detecting a vibration of the portable communication device; or f) detecting if the portable communication device is in a user's hand. How the method **50** can detect the conditions described above can be embodied in many different forms using individually or in combination sensors and timers and other devices.” Perez at [0022].

“1. A portable communication device, comprising:

a transceiver radio;

a display coupled to the transceiver radio;

<p>a sensor for detecting a user condition of the portable communication device, wherein the user condition can comprise a talk condition when the user is assumed to be talking on the portable communication device; and</p> <p>a processor programmed to at least reduce power provided to the display when the sensor detects the talk condition.” Perez at Claim 1.</p> <p>“5. The portable communication device of claim 1, wherein the sensor comprises a proximity sensor for detecting if a predetermined volume of acoustic sound is being received at a microphone indicative of a user talking on the portable communication device.” Perez at Claim 5.</p> <p>“6. The portable communication device of claim 1, wherein the sensor comprises an acoustic feedback algorithm that measures at least one among a spectrum density and a spectrum energy of a bounced signal to determine the proximity of a user's head to an earpiece of the portable communication device.” Perez at Claim 6.</p> <p>“18. A method of power management for a radio communication device having a display, comprising the steps of:</p> <p>detecting a talk condition;</p> <p>at least reducing the power provided to the display within a predetermined time of the talk condition.” Perez at Claim 18.</p> <p>“20. The method of claim 18, wherein the step of detecting a talk condition is selected from the group of conditions consisting of a) detecting if a predetermined volume of acoustic sound is being received at a microphone indicative of a user talking on the portable communication device; b) measuring at least one</p>	
--	--

among a spectrum density and a spectrum energy of a bounced signal to determine the proximity of a user's head to an earpiece of the portable communication device; c) measuring a predetermined period after a phone call starts; d) detecting an angle at which the portable communication device is positioned; e) detecting a vibration of the portable communication device; and f) detecting if the portable communication device is in a user's hand." Perez at Claim 20.

To the extent Perez is deemed to not expressly disclose that "the microprocessor reduces power to the display while the signal indicates the proximity of the external object only if the microprocessor determines that the wireless telephone call is active," Perez inherently discloses this limitation. The goal of Perez is to determine when a mobile station is in a "talk condition" in order to determine that the user is unlikely to be looking at the mobile station's display and that it can therefore be powered off and battery power can be conserved. *See, e.g.*, Perez at ¶ 0014 ("For example, the display 12 can have backlighting 14 and/or the keypads can have backlighting 19 as is well known in the industry. Although backlighting provides great ergonomic benefits to a user in visually reading a display or keypad, the additional current drain on a battery can significantly reduce overall talk time. Thus, to overcome this disadvantage, the present invention accounts for actual usage by a user by sensing a talk condition. A talk condition should generally be understood as the condition when a user is on an active call and speaking into the microphone 20 or listening to the earpiece 22"); Perez at Abstract ("A portable communication product (10) such as a cellular phone includes a transceiver radio having a microphone (20), an earpiece (22), a keypad (18) and a display (12) coupled to the transceiver radio. The portable communication product further includes at least one sensor (24, 26, 28, or 30) and a processor (16). The sensor can be used for detecting a user condition of the portable communication device such as a talk condition when the user is assumed to be talking on the portable communication product. The processor can be programmed to at least reduce power provided to the display when the sensor detects the talk condition."). Perez also discloses a number of in which a "talk condition" can be detected, including by detecting a certain volume of acoustic sound or detecting the proximity of user's head to the mobile station. *See, e.g.*, Perez at 0018 ("As mentioned previously, the step of detecting a talk condition can be achieved by monitoring or detecting at least one among the conditions of a) detecting if a predetermined volume of acoustic sound is being received at a microphone indicative of a user talking on the portable communication device; b) measuring at least one among a spectrum density and a spectrum energy of a bounced signal to determine the proximity of a user's head to an earpiece of the

portable communication device; c) measuring a predetermined period after a phone call starts; d) detecting an angle at which the portable communication device is positioned; e) detecting a vibration of the portable communication device; or f) detecting if the portable communication device is in a user's hand. How the method 50 can detect the conditions described above can be embodied in many different forms using individually or in combination sensors and timers and other devices.”). A person of ordinary skill in the art at the time of the alleged invention would understand that Perez, which seeks to conserve battery power by accounting for “actual usage by a user” is necessarily disclosing implement at least one other of its disclosed ways of detecting the talk condition in addition to detecting the “proximity of user’s head” to ensure that the “wireless telephone call is active” before powering off the display of the mobile station. Therefore, a person of ordinary skill in the art at the time of the alleged invention would understand that in Perez, necessarily “the microprocessor reduces power to the display while the signal indicates the proximity of the external object only if the microprocessor determines that the wireless telephone call is active.”

To the extent Perez is deemed to not expressly or inherently disclose that “the microprocessor reduces power to the display while the signal indicates the proximity of the external object only if the microprocessor determines that the wireless telephone call is active,” Perez renders this limitation obvious to one of ordinary skill in the art at the time of the alleged invention. The goal of Perez is to determine when a mobile station is in a “talk condition” in order to determine that the user is unlikely to be looking at the mobile station’s display and that it can therefore be powered off and battery power can be conserved. *See, e.g.*, Perez at ¶ 0014 (“For example, the display 12 can have backlighting 14 and/or the keypads can have backlighting 19 as is well known in the industry. Although backlighting provides great ergonomic benefits to a user in visually reading a display or keypad, the additional current drain on a battery can significantly reduce overall talk time. Thus, to overcome this disadvantage, the present invention accounts for actual usage by a user by sensing a talk condition. A talk condition should generally be understood as the condition when a user is on an active call and speaking into the microphone 20 or listening to the earpiece 22”); Perez at Abstract (“A portable communication product (10) such as a cellular phone includes a transceiver radio having a microphone (20), an earpiece (22), a keypad (18) and a display (12) coupled to the transceiver radio. The portable communication product further includes at least one sensor (24, 26, 28, or 30) and a processor (16). The sensor can be used for detecting a user condition of the portable communication device such as a talk condition when the user is assumed to be talking on the portable communication product. The

processor can be programmed to at least reduce power provided to the display when the sensor detects the talk condition.”). Perez also discloses a number of in which a “talk condition” can be detected, including by detecting a certain volume of acoustic sound or detecting the proximity of user’s head to the mobile station. *See, e.g.*, Perez at 0018 (“As mentioned previously, the step of detecting a talk condition can be achieved by monitoring or detecting at least one among the conditions of a) detecting if a predetermined volume of acoustic sound is being received at a microphone indicative of a user talking on the portable communication device; b) measuring at least one among a spectrum density and a spectrum energy of a bounced signal to determine the proximity of a user’s head to an earpiece of the portable communication device; c) measuring a predetermined period after a phone call starts; d) detecting an angle at which the portable communication device is positioned; e) detecting a vibration of the portable communication device; or f) detecting if the portable communication device is in a user’s hand. How the method 50 can detect the conditions described above can be embodied in many different forms using individually or in combination sensors and timers and other devices.”). It would be obvious to one of ordinary skill in the art at the time of the alleged invention to implement at least one of the other ways of detecting a “talk condition” disclosed in Perez in addition to detecting the “proximity of user’s head,” so as to ensure that the “wireless telephone call is active” before powering off the display of the mobile station. This would be in keeping with Perez’s goal of conserving battery power by accounting for “actual usage by a user.” Doing so would also constitute, at least, combining prior art elements according to known methods to yield predictable results, a simple substitution of one known element for another to obtain predictable results, the use of a known technique to improve similar devices in the same way, the application of a known technique to a known device ready for improvement to yield a predictable result, and obvious to try.

To the extent Perez is deemed to not expressly or inherently disclose that “the microprocessor reduces power to the display while the signal indicates the proximity of the external object only if the microprocessor determines that the wireless telephone call is active,” it would be obvious to combine the disclosure of Perez with those of Fukihara 598 as described in the Fukihara 598 claim chart, which is incorporated herein in its entirety by reference. Perez and Fukihara 598 are both directed to conserving battery power in mobile stations generally and more particularly at conserving battery power in mobile stations by using sensors to detect when the user of the mobile station is in a call and unlikely to be looking at the display (as when, for example, the proximity sensor detects the user’s ear by the mobile station) and to power off the display of mobile stations at such times. Perez at ¶ 0013 (“Referring to FIG. 1, a portable

communication product 10 such as a cellular phone includes a transeiver radio having a microphone 20, an earpiece 22, a keypad 18 and a display 12 (such as a color display) coupled to the transeiver radio. The portable communication product 10 further includes at least one sensor (24, 26, 28 or 30) and a processor 16. The sensor can be used for detecting a user condition of the portable communication device such as a talk condition when the user is assumed to be talking on the portable communication device. The processor 16 can be programmed to at least reduce power provided to the display 12 when the sensor detects the talk condition. The processor 16 can also turn off power to the display 12 during a talk condition if desired.”); Fukiharu 598 at ¶ 0018 (“The present invention, through the use of a structure as described above, enables a reduction in the consumption of battery power, through enabling the lighting devices to be turned OFF when the ear is caused to contact the receiver portion in order to hear the receiver sound during voice communications of a mobile telephone when the lighting devices (backlights) for a liquid crystal display device and keypad portion of a mobile telephone are lit, such as that night.”). A person of ordinary skill in the art at the time of the alleged invention would be motivated to modify Perez such that “the microprocessor reduces power to the display while the signal indicates the proximity of the external object only if the microprocessor determines that the wireless telephone call is active,” as disclosed in Fukihara 598 for a number of different reasons, including that it would support Perez’s ability to conserve battery power in mobile stations, and doing so would be within the knowledge and ability of a person of ordinary skill in the art at the time of the alleged invention. The combination would constitute, at least, combining prior art elements according to known methods to yield predictable results, a simple substitution of one known element for another to obtain predictable results, the use of a known technique to improve similar devices in the same way, the application of a known technique to a known device ready for improvement to yield a predictable result, and obvious to try.

To the extent Perez is deemed to not expressly or inherently disclose the microprocessor adapted to that “the microprocessor reduces power to the display while the signal indicates the proximity of the external object only if the microprocessor determines that the wireless telephone call is active,” it would be obvious to combine the disclosure of Perez with those of Numazawa as described in the Numazawa claim chart, which is incorporated herein in its entirety by reference. Perez and Numazawa are both directed to conserving battery power in mobile stations generally and more particularly at conserving battery power in mobile stations by using sensors to detect when the user of the mobile station is in a call and unlikely to be looking at the display (as when, for example, the proximity sensor detects the user’s ear by the mobile station) and to power off the display of mobile stations at such times. Perez at ¶ 0013 (“Referring to FIG. 1,

a portable communication product 10 such as a cellular phone includes a transceiver radio having a microphone 20, an earpiece 22, a keypad 18 and a display 12 (such as a color display) coupled to the transceiver radio. The portable communication product 10 further includes at least one sensor (24, 26, 28 or 30) and a processor 16. The sensor can be used for detecting a user condition of the portable communication device such as a talk condition when the user is assumed to be talking on the portable communication device. The processor 16 can be programmed to at least reduce power provided to the display 12 when the sensor detects the talk condition. The processor 16 can also turn off power to the display 12 during a talk condition if desired.”); Numazawa at ¶ Abstract (“To achieve reduced power consumption through stopping operation of unnecessary functions during use of a wireless terminal. A CPU 2 identifies start of a call state through a signal from a signal processing portion 3 for controlling communication with a base station, and identifies, through an output signal from detecting means 6, whether or not a user ear is in contact with a terminal. Upon identification of contact of the ear to the terminal, controlling means 8 are caused to stop the supply of electric power, from a power supply 7, to displaying means 9 for providing information to a user, and lighting means 10, such as a black light.”), ¶ 0005-0007 (“In the present invention, control is such that, upon determination that the wireless terminal is in a call, operation of functions believe be unnecessary, due to the user of the terminal being in a call, is stopped, and upon termination of the call, operation of the stopped functions is restarted. Additionally, because it is envisioned that there will also be cases where, even during a call, the face of the user may be separated from the receiver of the terminal, control is performed so as to enable restarting of the operations of the functions that had been stopped as unnecessary, through detecting whether or not the user of the terminal has the receiver in contact with an ear. The achievement of reduced power consumption through stopping operation of functions that become unnecessary in use of the terminal, as described above, can be anticipated to have the effect of extending the life of the power supply, such as a battery.”). A person of ordinary skill in the art at the time of the alleged invention would be motivated to modify Perez such that “the microprocessor reduces power to the display while the signal indicates the proximity of the external object only if the microprocessor determines that the wireless telephone call is active,” as disclosed in Numazawa for a number of different reasons, including that it would support Perez’s ability to conserve battery power in mobile stations, and doing so would be within the knowledge and ability of a person of ordinary skill in the art at the time of the alleged invention. The combination would constitute, at least, combining prior art elements according to known methods to yield predictable results, a simple substitution of one known element for another to obtain predictable results, the use of a known technique to improve similar devices in the same way, the application of a known technique to a known device ready for improvement to yield a predictable result, and obvious to try.

To the extent Perez is deemed to not expressly or inherently disclose that “the microprocessor reduces power to the display while the signal indicates the proximity of the external object only if the microprocessor determines that the wireless telephone call is active,” it would be obvious to combine the disclosure of Perez with those of Miyashita as described in the Miyashita claim chart, which is incorporated herein in its entirety by reference. Perez and Miyashita are both directed to conserving battery power in mobile stations generally and more particularly at conserving battery power in mobile stations by using sensors to detect when the user of the mobile station is in a call and unlikely to be looking at the display (as when, for example, the proximity sensor detects the user’s ear by the mobile station or a sensor detects that the mobile station is in a vertical orientation) and to power off the display of mobile stations at such times. Perez at ¶ 0013 (“Referring to FIG. 1, a portable communication product 10 such as a cellular phone includes a transceiver radio having a microphone 20, an earpiece 22, a keypad 18 and a display 12 (such as a color display) coupled to the transceiver radio. The portable communication product 10 further includes at least one sensor (24, 26, 28 or 30) and a processor 16. The sensor can be used for detecting a user condition of the portable communication device such as a talk condition when the user is assumed to be talking on the portable communication device. The processor 16 can be programmed to at least reduce power provided to the display 12 when the sensor detects the talk condition. The processor 16 can also turn off power to the display 12 during a talk condition if desired.”); Miyashita at 1:58-63 (“The present invention is directed to solving the problem set forth above. It is therefore an object of the present invention to provide a portable telephone set which can shut off the power supply for a display portion while a content of the display will not be seen during speaking, and thus can reduce power consumption.”), 2:6-11 (“In the preferred construction the detector is a gyro. The control apparatus may shut off the power supply for the display when the detector detects the main body at a substantially vertical position. On the other hand, the control may initiate power supply for the display when the detector detects the main body at a substantially horizontal position.”). A person of ordinary skill in the art at the time of the alleged invention would be motivated to modify Perez such that “the microprocessor reduces power to the display while the signal indicates the proximity of the external object only if the microprocessor determines that the wireless telephone call is active,” as disclosed in Miyashita for a number of different reasons, including that it would support Perez’s ability to conserve battery power in mobile stations, and doing so would be within the knowledge and ability of a person of ordinary skill in the art at the time of the alleged invention. The combination would constitute, at least, combining prior art elements according to known methods to yield predictable results, a simple substitution of one known element for another to obtain predictable results, the

<p>[11] the proximity sensor begins detecting whether an external object is proximate substantially concurrently with the mobile station initiating an outgoing wireless telephone call or receiving an incoming wireless telephone call.</p>	<p>use of a known technique to improve similar devices in the same way, the application of a known technique to a known device ready for improvement to yield a predictable result, and obvious to try.</p>
<p>Perez discloses that the proximity sensor begins to detect whether an external object is proximate substantially concurrently with the mobile station initiating an outgoing wireless telephone call or receiving an incoming wireless telephone call:</p> <p>For example: <i>see</i> discussion of claim element [1f], <i>supra</i>, which is incorporated herein by reference.</p> <p>“The step of detecting a talk condition can be selected from the group of conditions consisting of a) detecting if a predetermined volume of acoustic sound is being received at a microphone indicative of a user talking on the portable communication device; b) measuring at least one among a spectrum density and a spectrum energy of a bounced signal to determine the proximity of a user’s head to an earpiece of the portable communication device; c) measuring a predetermined period after a phone call starts; d) detecting an angle at which the portable communication device is positioned; e) detecting a vibration of the portable communication device; and f) detecting if the portable communication device is in a user’s hand.” Perez at [0009].</p> <p>“Referring to FIG. 1, a portable communication product 10 such as a cellular phone includes a transceiver radio having a microphone 20, an earpiece 22, a keypad 18 and a display 12 (such as a color display) coupled to the transceiver radio. The portable communication product 10 further includes at least one sensor (24, 26, 28 or 30) and a processor 16. The sensor can be used for detecting a user condition of the portable communication device such as a talk condition when the user is assumed to be talking on the portable communication device. The processor 16 can be programmed to at least reduce power provided to the display 12 when the sensor detects the talk condition. The processor 16 can also turn off power to the display 12 during a talk condition if desired.” Perez at [0013].</p>	<p>Perez discloses that the proximity sensor begins to detect whether an external object is proximate substantially concurrently with the mobile station initiating an outgoing wireless telephone call or receiving an incoming wireless telephone call:</p> <p>For example: <i>see</i> discussion of claim element [1f], <i>supra</i>, which is incorporated herein by reference.</p> <p>“The step of detecting a talk condition can be selected from the group of conditions consisting of a) detecting if a predetermined volume of acoustic sound is being received at a microphone indicative of a user talking on the portable communication device; b) measuring at least one among a spectrum density and a spectrum energy of a bounced signal to determine the proximity of a user’s head to an earpiece of the portable communication device; c) measuring a predetermined period after a phone call starts; d) detecting an angle at which the portable communication device is positioned; e) detecting a vibration of the portable communication device; and f) detecting if the portable communication device is in a user’s hand.” Perez at [0009].</p> <p>“Referring to FIG. 1, a portable communication product 10 such as a cellular phone includes a transceiver radio having a microphone 20, an earpiece 22, a keypad 18 and a display 12 (such as a color display) coupled to the transceiver radio. The portable communication product 10 further includes at least one sensor (24, 26, 28 or 30) and a processor 16. The sensor can be used for detecting a user condition of the portable communication device such as a talk condition when the user is assumed to be talking on the portable communication device. The processor 16 can be programmed to at least reduce power provided to the display 12 when the sensor detects the talk condition. The processor 16 can also turn off power to the display 12 during a talk condition if desired.” Perez at [0013].</p>

“A talk condition can be sensed in quite a number of ways. After the talk condition is detected or sensed, at least one or more among the display 12, the backlight 14 (for the display), or the backlight 19 (for the keypad) can be turned off or at least operate at a reduced power level. A talk condition, for example, can be sensed by detecting if a predetermined volume of acoustic sound is being received at the microphone 20 or at another sensor such as a proximity sensor 26 indicative of a user talking on the portable communication device. The sensors 20 or 26 can detect if a predetermined volume of acoustic sound is being received at either sensor. Alternatively, a talk condition can be sensed by measuring at least one among a spectrum density or a spectrum energy of a bounced signal to determine the proximity of a user's head to an earpiece of the portable communication device using a microphone or a proximity sensor 24 as further detailed with respect to FIG. 3. A talk condition can also be sensed by detecting an angle at which the portable communication device 10 is positioned or by detecting a vibration of the portable communication device 10. There is no need to keep the display 12 on if the phone is sitting idle. Ergonomically, a phone will be used at a certain predetermined angle-range anytime a phone call is active and the user is listening to the earpiece. A sensor 28 for sensing either the angle or a vibration of the portable communication device can be embodied by a microelectronic mechanical systems (MEMS) device. Another way for sensing a talk condition can be achieved by sensing if the portable communication device 10 is in a user's hand. A sensor 30 can be a differential pressure sensor or a thermal sensor that indicates that the phone is in a user's hands. All the sensors described above should be considered environmental sensors with respect to the present invention.” Perez at [0015].

“As mentioned previously, the step of detecting a talk condition can be achieved by monitoring or detecting at least one among the conditions of a) detecting if a predetermined volume of acoustic sound is being received at a microphone indicative of a user talking on the portable communication device; b) measuring at least one among a spectrum density and a spectrum energy of a bounced signal to determine the proximity of a user's head to an earpiece of the portable communication device; c) measuring a predetermined period after a phone call starts; d) detecting an angle at which the portable communication device is positioned; e) detecting a vibration of the portable communication device; or f) detecting if the portable communication device is in a user's hand. How the method 50 can detect the conditions described above can be embodied in many different forms using individually or in combination sensors and timers and other devices.” Perez at [0022].

“1. A portable communication device, comprising:

a transmitter radio;

a display coupled to the transmitter radio;

a sensor for detecting a user condition of the portable communication device, wherein the user condition can comprise a talk condition when the user is assumed to be talking on the portable communication device; and

a processor programmed to at least reduce power provided to the display when the sensor detects the talk condition.” Perez at Claim 1.

“6. The portable communication device of claim 1, wherein the sensor comprises an acoustic feedback algorithm that measures at least one among a spectrum density and a spectrum energy of a bounced signal to determine the proximity of a user's head to an earpiece of the portable communication device.” Perez at Claim 6.

To the extent Perez is deemed to not expressly disclose “the proximity sensor begins detecting whether an external object is proximate substantially concurrently with the mobile station initiating an outgoing wireless telephone call or receiving an incoming wireless telephone call,” Perez inherently discloses this limitation. In Perez, the use of a proximity sensor is disclosed as one out of several ways that a mobile station can detect that it is in a “talk condition.” *See, e.g.*, Perez at ¶ 0015 (“A talk condition can be sensed in quite a number of ways A talk condition, for example, can be sensed by . . . measuring at least one among a spectrum density or a spectrum energy of a bounced signal to determine the proximity of a user's head to an earpiece of the portable communication device using a microphone or a proximity sensor 24 as further detailed with respect to FIG. 3.”). Perez also discloses that “[a] talk condition should generally be understood as the condition when a user is on an active call and speaking into the microphone 20 or listening to the earpiece 22.” Perez at ¶ 0014. A person of ordinary skill in the art at the time of the alleged invention would understand that “initiating an outgoing wireless telephone call or receiving an incoming wireless telephone call” is how a mobile station enters into a “talk condition.” Further, a person of ordinary skill in the art

would understand that “the proximity sensor begins detecting whether an external object is proximate substantially concurrently with the mobile station initiating an outgoing wireless telephone call or receiving an incoming wireless telephone call” because the function of the proximity sensor in Perez is to detect the “talk condition” so as to disable the display of the mobile station as soon as the detection takes place in order to conserve battery. Thus, a person of ordinary skill in the art at the time of the alleged invention would understand Perez to inherently disclose that “the proximity sensor begins detecting whether an external object is proximate substantially concurrently with the mobile station initiating an outgoing wireless telephone call or receiving an incoming wireless telephone call.”

To the extent Perez is deemed to not expressly or inherently disclose “the proximity sensor begins detecting whether an external object is proximate substantially concurrently with the mobile station initiating an outgoing wireless telephone call or receiving an incoming wireless telephone call,” Perez renders it obvious to one of skill in the art to have “the proximity sensor begin[] detecting whether an external object is proximate substantially concurrently with the mobile station initiating an outgoing wireless telephone call or receiving an incoming wireless telephone call.” A person of ordinary skill in the art at the time of the alleged invention would understand that “initiating an outgoing wireless telephone call or receiving an incoming wireless telephone call” is how a mobile station enters into a “talk condition.” Further, it would be obvious to a person of ordinary skill in the art at the time of the alleged invention for “the proximity sensor [to] begin[] detecting whether an external object is proximate substantially concurrently with the mobile station initiating an outgoing wireless telephone call or receiving an incoming wireless telephone call” because the function of the proximity sensor in Perez is to detect the “talk condition” so as to disable the display of the mobile station as soon as the detection takes place in order to conserve battery. Starting to detect the “talk condition” via the proximity sensor as soon as the mobile station enters into the “talk condition” would support Perez’s goal of battery conservation, and it would be obvious to a person of ordinary skill in the art at the time of the alleged invention that the proximity sensor should begin detecting substantially concurrently with the start of this period in order to save additional power. Doing so would constitute, at least, combining prior art elements according to known methods to yield predictable results, a simple substitution of one known element for another to obtain predictable results, the use of a known technique to improve similar devices in the same way, the application of a known technique to a known device ready for improvement to yield a predictable result, and obvious to try.

To the extent Perez is deemed to not expressly or inherently disclose “the proximity sensor begins detecting whether an external object is proximate substantially concurrently with the mobile station initiating an outgoing wireless telephone call or receiving an incoming wireless telephone call,” it would be obvious to combine the disclosure of Perez with those of Fukiharu 598 as described in the Fukiharu 598 claim chart, which is incorporated herein in its entirety by reference. Perez and Fukiharu 598 are both directed to conserving battery power in mobile stations generally and more particularly at conserving battery power in mobile stations by using sensors to detect when the user of the mobile station is in a call and unlikely to be looking at the display (as when, for example, the proximity sensor detects the user’s ear by the mobile station) and to power off the display of mobile stations at such times. Perez at ¶ 0013 (“Referring to FIG. 1, a portable communication product 10 such as a cellular phone includes a transceiver radio having a microphone 20, an earpiece 22, a keypad 18 and a display 12 (such as a color display) coupled to the transceiver radio. The portable communication product 10 further includes at least one sensor (24, 26, 28 or 30) and a processor 16. The sensor can be used for detecting a user condition of the portable communication device such as a talk condition when the user is assumed to be talking on the portable communication device. The processor 16 can be programmed to at least reduce power provided to the display 12 when the sensor detects the talk condition. The processor 16 can also turn off power to the display 12 during a talk condition if desired.”); Fukiharu 598 at ¶ 0018 (“The present invention, through the use of a structure as described above, enables a reduction in the consumption of battery power, through enabling the lighting devices to be turned OFF when the ear is caused to contact the receiver portion in order to hear the receiver sound during voice communications of a mobile telephone when the lighting devices (backlights) for a liquid crystal display device and keypad portion of a mobile telephone are lit, such as that night.”). A person of ordinary skill in the art at the time of the alleged invention would be motivated to modify Perez to have “the proximity sensor begin[] detecting whether an external object is proximate substantially concurrently with the mobile station initiating an outgoing wireless telephone call or receiving an incoming wireless telephone call” as disclosed in Fukiharu 598 for a number of different reasons, including that it would support Perez’s ability to conserve battery power in mobile stations, and doing so would be within the knowledge and ability of a person of ordinary skill in the art at the time of the alleged invention. The combination would constitute, at least, combining prior art elements according to known methods to yield predictable results, a simple substitution of one known element for another to obtain predictable results, the use of a known technique to improve similar devices in the same way, the application of a known technique to a known device ready for improvement to yield a predictable result, and obvious to try.

To the extent Perez is deemed to not expressly or inherently disclose “the proximity sensor begins detecting whether an external object is proximate substantially concurrently with the mobile station initiating an outgoing wireless telephone call or receiving an incoming wireless telephone call,” it would be obvious to combine the disclosure of Perez with those of Numazawa as described in the Numazawa claim chart, which is incorporated herein in its entirety by reference. Perez and Numazawa are both directed to conserving battery power in mobile stations generally and more particularly at conserving battery power in mobile stations by using sensors to detect when the user of the mobile station is in a call and unlikely to be looking at the display (as when, for example, the proximity sensor detects the user’s ear by the mobile station) and to power off the display of mobile stations at such times. Perez at ¶ 0013 (“Referring to FIG. 1, a portable communication product 10 such as a cellular phone includes a transceiver radio having a microphone 20, an earpiece 22, a keypad 18 and a display 12 (such as a color display) coupled to the transceiver radio. The portable communication product 10 further includes at least one sensor (24, 26, 28 or 30) and a processor 16. The sensor can be used for detecting a user condition of the portable communication device such as a talk condition when the user is assumed to be talking on the portable communication device. The processor 16 can be programmed to at least reduce power provided to the display 12 when the sensor detects the talk condition. The processor 16 can also turn off power to the display 12 during a talk condition if desired.”); Numazawa at ¶ Abstract (“To achieve reduced power consumption through stopping operation of unnecessary functions during use of a wireless terminal. A CPU 2 identifies start of a call state through a signal from a signal processing portion 3 for controlling communication with a base station, and identifies, through an output signal from detecting means 6, whether or not a user ear is in contact with a terminal. Upon identification of contact of the ear to the terminal, controlling means 8 are caused to stop the supply of electric power, from a power supply 7, to displaying means 9 for providing information to a user, and lighting means 10, such as a black light.”), ¶ 0005-0007 (“In the present invention, control is such that, upon determination that the wireless terminal is in a call, operation of functions believe be unnecessary, due to the user of the terminal being in a call, is stopped, and upon termination of the call, operation of the stopped functions is restarted. Additionally, because it is envisioned that there will also be cases where, even during a call, the face of the user may be separated from the receiver of the terminal, control is performed so as to enable restarting of the operations of the functions that had been stopped as unnecessary, through detecting whether or not the user of the terminal has the receiver in contact with an ear. The achievement of reduced power consumption through stopping operation of functions that become unnecessary in use of the terminal, as described above, can be anticipated to have the effect of extending the life of the power supply, such as a battery.”) A person of ordinary skill in the art at the time of the alleged invention would

be motivated to modify Perez to have “the proximity sensor begin[] detecting whether an external object is proximate substantially concurrently with the mobile station initiating an outgoing wireless telephone call or receiving an incoming wireless telephone call” as disclosed in Numazawa for a number of different reasons, including that it would support Perez’s ability to conserve battery power in mobile stations, and doing so would be within the knowledge and ability of a person of ordinary skill in the art at the time of the alleged invention. The combination would constitute, at least, combining prior art elements according to known methods to yield predictable results, a simple substitution of one known element for another to obtain predictable results, the use of a known technique to improve similar devices in the same way, the application of a known technique to a known device ready for improvement to yield a predictable result, and obvious to try.

To the extent Perez is deemed to not expressly or inherently disclose “the proximity sensor begins detecting whether an external object is proximate substantially concurrently with the mobile station initiating an outgoing wireless telephone call or receiving an incoming wireless telephone call,” it would be obvious to combine the disclosure of Perez with those of Miyashita as described in the Miyashita claim chart, which is incorporated herein in its entirety by reference. Perez and Miyashita are both directed to conserving battery power in mobile stations generally and more particularly at conserving battery power in mobile stations by using sensors to detect when the user of the mobile station is in a call and unlikely to be looking at the display (as when, for example, the proximity sensor detects the user’s ear by the mobile station or a sensor detects that the mobile station is in a vertical orientation) and to power off the display of mobile stations at such times. Perez at ¶ 0013 (“Referring to FIG. 1, a portable communication product 10 such as a cellular phone includes a transceiver radio having a microphone 20, an earpiece 22, a keypad 18 and a display 12 (such as a color display) coupled to the transceiver radio. The portable communication product 10 further includes at least one sensor (24, 26, 28 or 30) and a processor 16. The sensor can be used for detecting a user condition of the portable communication device such as a talk condition when the user is assumed to be talking on the portable communication device. The processor 16 can be programmed to at least reduce power provided to the display 12 when the sensor detects the talk condition. The processor 16 can also turn off power to the display 12 during a talk condition if desired.”); Miyashita at 3:58-4:2 (“In contrast, the display control portion 17 is responsive to the inclination angle information indicative of variation of the inclination angle from the substantially horizontal orientation to the substantially vertical orientation while it performs display control for the display portion 16 to display the control information, to terminate the power supply for the display portion 16. When speaking is performed with the destination person via the

	<p>speaker 12 and the microphone 14, it is rare to require seeing the display content on the display portion 16. Therefore, the power supply for the display portion 16 is shut down. Thus, exhausting of a battery can be reduced.’). While Miyashita discloses a gyro, it would be obvious to one of ordinary skill in the art at the time of the alleged invention to make Perez’s proximity sensor to function in the same way as the gyro in Miyashita as both sensors serve the same function (to serve as an indication that the mobile station’s display is unlikely to be viewed and can therefore be powered off). A person of ordinary skill in the art at the time of the alleged invention would therefore be motivated to modify Perez to have “the proximity sensor begin[] detecting whether an external object is proximate substantially concurrently with the mobile station initiating an outgoing wireless telephone call or receiving an incoming wireless telephone call” as disclosed in Miyashita for a number of different reasons, including that it would support Perez’s ability to conserve battery power in mobile stations, and doing so would be within the knowledge and ability of a person of ordinary skill in the art at the time of the alleged invention. The combination would constitute, at least, combining prior art elements according to known methods to yield predictable results, a simple substitution of one known element for another to obtain predictable results, the use of a known technique to improve similar devices in the same way, the application of a known technique to a known device ready for improvement to yield a predictable result, and obvious to try.</p>
<p>[Claim 2] The mobile station of claim 1, wherein the microprocessor reduces power to the display only if (i) the microprocessor determines that a telephone call is active and (ii) the signal indicates the proximity of the external object.</p>	<p>Perez discloses the microprocessor reducing power to the display only if (i) the microprocessor determines that a telephone call is active and (ii) the signal indicates the proximity of the external object.</p> <p>For example: <i>see</i> discussion of claim elements [1f], [1h], <i>supra</i>, which are incorporated herein by reference.</p> <p>To the extent Perez is deemed to not expressly disclose this claim limitation, Perez inherently discloses this limitation. <i>See</i> discussion of claim element [1h], <i>supra</i>, which is incorporated herein by reference.</p> <p>To the extent Perez is deemed to not expressly or inherently disclose this claim limitation, Perez renders it obvious to one of skill in the art at the time of the alleged invention. <i>See</i> discussion of claim element [1h], <i>supra</i>, which is incorporated herein by reference.</p>

	<p>To the extent Perez is deemed to not expressly or inherently disclose this claim element, it would be obvious to combine the disclosure of Perez with those of Fukiharu 598 as described in the Fukiharu 598 claim chart, which is incorporated herein in its entirety by reference. See discussion of claim element [1h], <i>supra</i>, which is incorporated herein by reference.</p> <p>To the extent Perez is deemed to not expressly or inherently disclose this claim element, it would be obvious to combine the disclosure of Perez with those of Numazawa as described in the Numazawa claim chart, which is incorporated herein in its entirety by reference. See discussion of claim element [1h], <i>supra</i>, which is incorporated herein by reference.</p> <p>To the extent Perez is deemed to not expressly or inherently disclose this claim element, it would be obvious to combine the disclosure of Perez with those of Miyashita as described in the Miyashita claim chart, which is incorporated herein in its entirety by reference. See discussion of claim element [1h], <i>supra</i>, which is incorporated herein by reference.</p>
<p>[Claim 4] The mobile station as recited in claim 1, wherein the microprocessor reduces power to the display by turning off the display.</p>	<p>Perez discloses the microprocessor reducing power to the display by turning off the display.</p> <p>For example:</p> <p><i>See</i> discussion of claim element [1f], <i>supra</i>, which is incorporated herein by reference.</p>
<p>[Claim 5] The mobile station as recited in claim 1, wherein the proximity sensor is a mechanical proximity sensor, an</p>	<p>Perez discloses that the proximity sensor is a mechanical proximity sensor, an optical sensor, or a range-detecting sensor.</p> <p>For example:</p>

optical sensor, or a range-detecting sensor.

“A talk condition can be sensed in quite a number of ways. After the talk condition is detected or sensed, at least one or more among the display 12, the backlight 14 (for the display), or the backlight 19 (for the keypad) can be turned off or at least operate at a reduced power level. A talk condition, for example, can be sensed by detecting if a predetermined volume of acoustic sound is being received at the microphone 20 or at another sensor such as a proximity sensor 26 indicative of a user talking on the portable communication device. The sensors 20 or 26 can detect if a predetermined volume of acoustic sound is being received at either sensor. Alternatively, a talk condition can be sensed by measuring at least one among a spectrum density or a spectrum energy of a bounced signal to determine the proximity of a user's head to an earpiece of the portable communication device using a microphone or a proximity sensor 24 as further detailed with respect to FIG. 3. A talk condition can also be sensed by detecting an angle at which the portable communication device 10 is positioned or by detecting a vibration of the portable communication device 10. There is no need to keep the display 12 on if the phone is sitting idle. Ergonomically, a phone will be used at a certain predetermined angle-range anytime a phone call is active and the user is listening to the earpiece. A sensor 28 for sensing either the angle or a vibration of the portable communication device can be embodied by a microelectronic mechanical systems (MEMS) device. Another way for sensing a talk condition can be achieved by sensing if the portable communication device 10 is in a user's hand. A sensor 30 can be a differential pressure sensor or a thermal sensor that indicates that the phone is in a user's hands. All the sensors described above should be considered environmental sensors with respect to the present invention.” Perez at [0015].

“In one particular embodiment as shown in FIG. 3, the sensor or sensors 100 can comprise the earpiece 22, the microphone 24, a coder/decoder 104 and a digital signal processor (DSP) 102. The sensor 100 can utilize an acoustic feedback algorithm that measures at least a spectrum density or a spectrum energy of a bounced signal to determine the proximity of a user's head to the earpiece 22 of the portable communication device. The sensor 100 can also be used to control the outbound audio quality or provide a constant audio level (from the perspective of the user) by automatically adjusting the audio level based on the proximity to the ear of the user. This automatic adjustment can additionally lower the power consumption by the audio coder/decoder 104.” Perez at [0019].

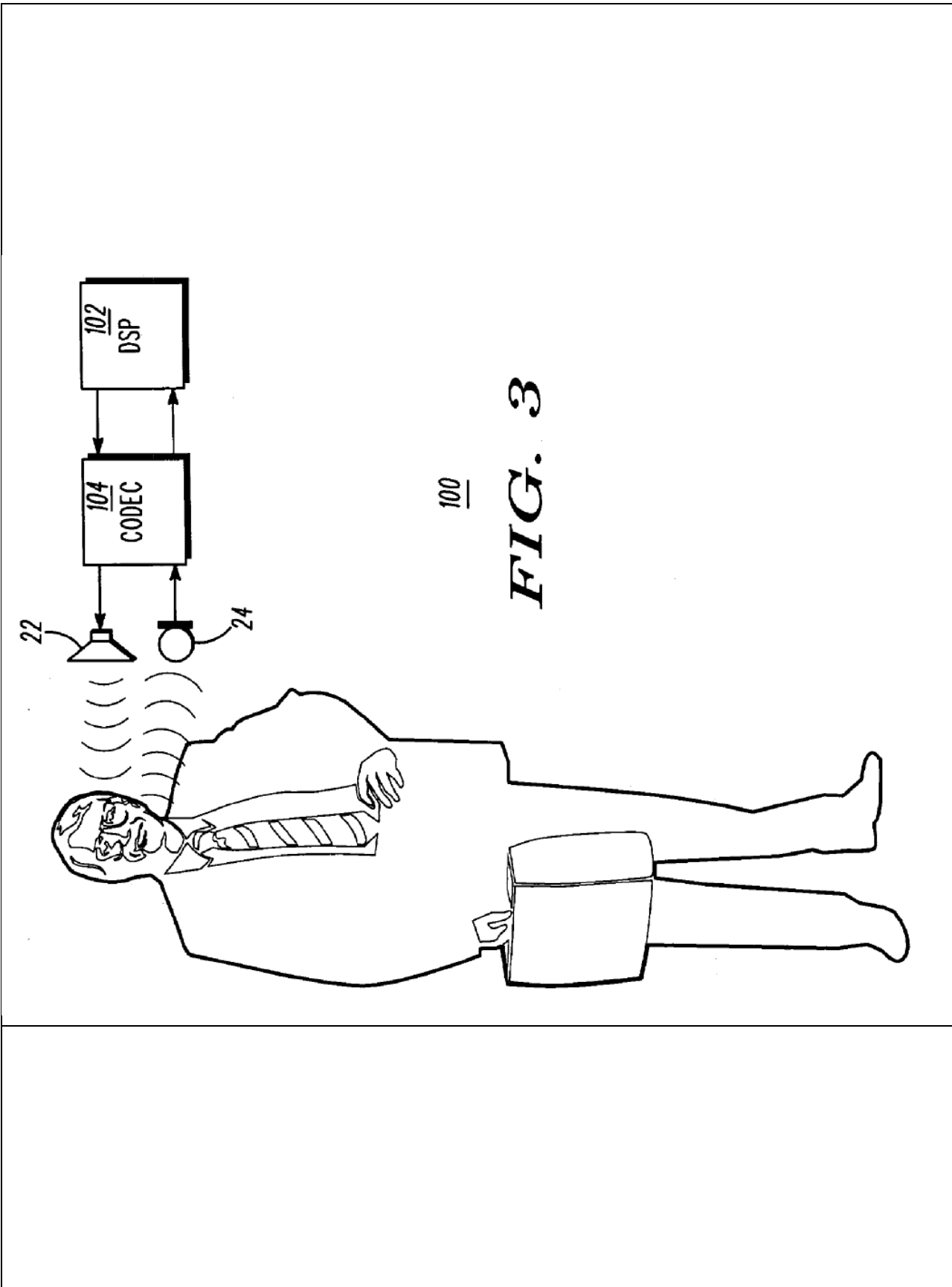

100
FIG. 3

Perez at Fig. 3.

“5. The portable communication device of claim 1, wherein the sensor comprises a proximity sensor for detecting if a predetermined volume of acoustic sound is being received at a microphone indicative of a user talking on the portable communication device.” Perez at Claim 5.

“6. The portable communication device of claim 1, wherein the sensor comprises an acoustic feedback algorithm that measures at least one among a spectrum density and a spectrum energy of a bounced signal to determine the proximity of a user's head to an earpiece of the portable communication device.” Perez at Claim 6.

To the extent Perez is deemed to not expressly or inherently disclose “the proximity sensor is a mechanical proximity sensor, an optical sensor, or a range-detecting sensor,” Perez renders it obvious to one of ordinary skill in the art at the time of the alleged invention to use a mechanical proximity sensor. A person of ordinary skill in the art at the time of the alleged invention would be aware of “conventional mechanical proximity (load) sensors,” which the '889 Patent identifies as known prior art. *See* '889 Patent at 3:15-20. A person of ordinary skill in the art at the time of the alleged invention would understand that a mechanical proximity sensor could be used to detect contact with a portion of the human body, such as an ear. Using a mechanical proximity sensor would constitute, at least, combining prior art elements according to known methods to yield predictable results, a simple substitution of one known element for another to obtain predictable results, the use of a known technique to improve similar devices in the same way, the application of a known technique to a known device ready for improvement to yield a predictable result, and obvious to try.

To the extent Perez is deemed to not expressly or inherently disclose “the proximity sensor is a mechanical proximity sensor, an optical sensor, or a range-detecting sensor,” it would be obvious to combine the disclosure of Perez with those of Fukiharu 598 as described in the Fukiharu 598 claim chart, which is

incorporated herein in its entirety by reference. Perez and Fukiharu 598 are both directed to conserving battery power in mobile stations generally and more particularly at conserving battery power in mobile stations by using sensors to detect when the user of the mobile station is in a call and unlikely to be looking at the display (as when, for example, the proximity sensor detects the user's ear by the mobile station) and to power off the display of mobile stations at such times. Perez at ¶ 0013 (“Referring to FIG. 1, a portable communication product 10 such as a cellular phone includes a transceiver radio having a microphone 20, an earpiece 22, a keypad 18 and a display 12 (such as a color display) coupled to the transceiver radio. The portable communication product 10 further includes at least one sensor (24, 26, 28 or 30) and a processor 16. The sensor can be used for detecting a user condition of the portable communication device such as a talk condition when the user is assumed to be talking on the portable communication device. The processor 16 can be programmed to at least reduce power provided to the display 12 when the sensor detects the talk condition. The processor 16 can also turn off power to the display 12 during a talk condition if desired.”); Fukiharu 598 at ¶ 0018 (“The present invention, through the use of a structure as described above, enables a reduction in the consumption of battery power, through enabling the lighting devices to be turned OFF when the ear is caused to contact the receiver portion in order to hear the receiver sound during voice communications of a mobile telephone when the lighting devices (backlights) for a liquid crystal display device and keypad portion of a mobile telephone are lit, such as that night.”). A person of ordinary skill in the art at the time of the alleged invention would be motivated to modify Perez such that “the proximity sensor is a mechanical proximity sensor, an optical sensor, or a range-detecting sensor,” as disclosed in Fukiharu 598 for a number of different reasons, including that it would support Perez’s ability to conserve battery power in mobile stations, and doing so would be within the knowledge and ability of a person of ordinary skill in the art at the time of the alleged invention. The combination would constitute, at least, combining prior art elements according to known methods to yield predictable results, a simple substitution of one known element for another to obtain predictable results, the use of a known technique to improve similar devices in the same way, the application of a known technique to a known device ready for improvement to yield a predictable result, and obvious to try.

To the extent Perez is deemed to not expressly or inherently disclose “the proximity sensor is a mechanical proximity sensor, an optical sensor, or a range-detecting sensor,” it would be obvious to combine the disclosure of Perez with those of Numazawa as described in the Numazawa claim chart, which is incorporated herein in its entirety by reference. Perez and Numazawa are both directed to conserving battery power in mobile stations generally and more particularly at conserving battery power in mobile

stations by using sensors to detect when the user of the mobile station is in a call and unlikely to be looking at the display (as when, for example, the proximity sensor detects the user's ear by the mobile station) and to power off the display of mobile stations at such times. Perez at ¶ 0013 (“Referring to FIG. 1, a portable communication product 10 such as a cellular phone includes a transmitter radio having a microphone 20, an earpiece 22, a keypad 18 and a display 12 (such as a color display) coupled to the transmitter radio. The portable communication product 10 further includes at least one sensor (24, 26, 28 or 30) and a processor 16. The sensor can be used for detecting a user condition of the portable communication device such as a talk condition when the user is assumed to be talking on the portable communication device. The processor 16 can be programmed to at least reduce power provided to the display 12 when the sensor detects the talk condition. The processor 16 can also turn off power to the display 12 during a talk condition if desired.”); Numazawa at ¶ Abstract (“To achieve reduced power consumption through stopping operation of unnecessary functions during use of a wireless terminal. A CPU 2 identifies start of a call state through a signal from a signal processing portion 3 for controlling communication with a base station, and identifies, through an output signal from detecting means 6, whether or not a user ear is in contact with a terminal. Upon identification of contact of the ear to the terminal, controlling means 8 are caused to stop the supply of electric power, from a power supply 7, to displaying means 9 for providing information to a user, and lighting means 10, such as a black light.”), ¶ 0005-0007 (“In the present invention, control is such that, upon determination that the wireless terminal is in a call, operation of functions believe be unnecessary, due to the user of the terminal being in a call, is stopped, and upon termination of the call, operation of the stopped functions is restarted. Additionally, because it is envisioned that there will also be cases where, even during a call, the face of the user may be separated from the receiver of the terminal, control is performed so as to enable restarting of the operations of the functions that had been stopped as unnecessary, through detecting whether or not the user of the terminal has the receiver in contact with an ear. The achievement of reduced power consumption through stopping operation of functions that become unnecessary in use of the terminal, as described above, can be anticipated to have the effect of extending the life of the power supply, such as a battery.”) A person of ordinary skill in the art at the time of the alleged invention would be motivated to modify Perez to have “the proximity sensor is a mechanical proximity sensor, an optical sensor, or a range-detecting sensor,” as disclosed in Numazawa for a number of different reasons, including that it would support Perez’s ability to conserve battery power in mobile stations, and doing so would be within the knowledge and ability of a person of ordinary skill in the art at the time of the alleged invention. The combination would constitute, at least, combining prior art elements according to known methods to yield predictable results, a simple substitution of one known element for another to obtain predictable

	<p>results, the use of a known technique to improve similar devices in the same way, the application of a known technique to a known device ready for improvement to yield a predictable result, and obvious to try.</p>
<p>[Claim 6] The mobile station as recited in claim 1, wherein the proximity sensor is located proximate to the display.</p>	<p>Perez discloses that the proximity sensor is located proximate to the display.</p> <p>For example:</p> <p>“Referring to FIG. 1, a portable communication product 10 such as a cellular phone includes a transceiver radio having a microphone 20, an earpiece 22, a keypad 18 and a display 12 (such as a color display) coupled to the transceiver radio. The portable communication product 10 further includes at least one sensor (24, 26, 28 or 30) and a processor 16. The sensor can be used for detecting a user condition of the portable communication device such as a talk condition when the user is assumed to be talking on the portable communication device. The processor 16 can be programmed to at least reduce power provided to the display 12 when the sensor detects the talk condition. The processor 16 can also turn off power to the display 12 during a talk condition if desired.” Perez at [0013].</p>

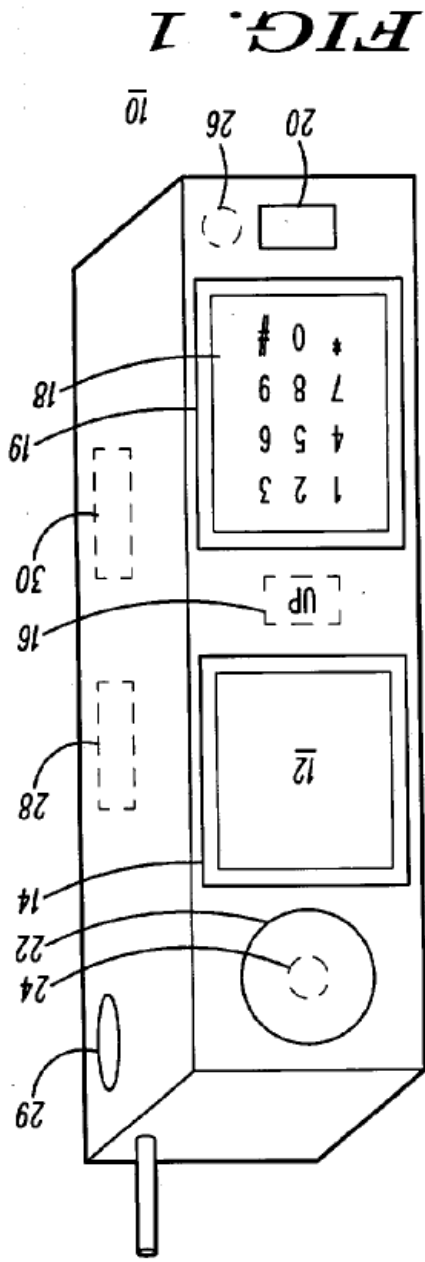

Perez at Fig. 1.

To the extent Seo is deemed to not expressly disclose “the proximity sensor is located proximate to the display,” Perez inherently discloses this limitation. Perez discloses that its invention cuts power to the display during a call when the user has the receiver against his or her ear because the display is an unnecessary function at this time, i.e., it is not visible. A person of ordinary skill in the art at the time of the alleged invention would understand that the display is not visible because the user’s head is against it and, if the detecting means is to detect this, it should be “located proximate to the display.” Thus, a person of ordinary skill in the art at the time of the alleged invention would understand Perez to inherently disclose that “the proximity sensor is located proximate to the display.”

To the extent Perez is deemed to not expressly or inherently disclose “the proximity sensor is located proximate to the display,” Perez renders it obvious to one of skill in the art to have “the proximity sensor . . . located proximate to the display.” It would be obvious to a person of ordinary skill in the art at the time of

the alleged invention that “the proximity sensor is located proximate to the display” because, in this location, it can determine that the display is not visible because the user’s head is against it. This would constitute, at least, combining prior art elements according to known methods to yield predictable results, a simple substitution of one known element for another to obtain predictable results, the use of a known technique to improve similar devices in the same way, the application of a known technique to a known device ready for improvement to yield a predictable result, and obvious to try.

To the extent Perez is deemed to not expressly or inherently disclose “the proximity sensor is located proximate to the display,” it would be obvious to combine the disclosure of Perez with those of Fukiharu 598 as described in the Fukiharu 598 claim chart, which is incorporated herein in its entirety by reference. Perez and Fukiharu 598 are both directed to conserving battery power in mobile stations generally and more particularly at conserving battery power in mobile stations by using sensors to detect when the user of the mobile station is in a call and unlikely to be looking at the display (as when, for example, the proximity sensor detects the user’s ear by the mobile station) and to power off the display of mobile stations at such times. Perez at ¶ 0013 (“Referring to FIG. 1, a portable communication product 10 such as a cellular phone includes a transceiver radio having a microphone 20, an earpiece 22, a keypad 18 and a display 12 (such as a color display) coupled to the transceiver radio. The portable communication product 10 further includes at least one sensor (24, 26, 28 or 30) and a processor 16. The sensor can be used for detecting a user condition of the portable communication device such as a talk condition when the user is assumed to be talking on the portable communication device. The processor 16 can be programmed to at least reduce power provided to the display 12 when the sensor detects the talk condition. The processor 16 can also turn off power to the display 12 during a talk condition if desired.”); Fukiharu 598 at ¶ 0018 (“The present invention, through the use of a structure as described above, enables a reduction in the consumption of battery power, through enabling the lighting devices to be turned OFF when the ear is caused to contact the receiver portion in order to hear the receiver sound during voice communications of a mobile telephone when the lighting devices (backlights) for a liquid crystal display device and keypad portion of a mobile telephone are lit, such as that night.”). A person of ordinary skill in the art at the time of the alleged invention would be motivated to modify Perez to have “the proximity sensor is located proximate to the display” as disclosed in Fukiharu 598 to determine that the display is not visible because the user’s head is against it. The combination would constitute, at least, combining prior art elements according to known methods to yield predictable results, a simple substitution of one known element for another to obtain predictable results, the use of a known

technique to improve similar devices in the same way, the application of a known technique to a known device ready for improvement to yield a predictable result, and obvious to try.

To the extent Perez is deemed to not expressly or inherently disclose “the proximity sensor is located proximate to the display,” it would be obvious to combine the disclosure of Perez with those of Numazawa as described in the Numazawa claim chart, which is incorporated herein in its entirety by reference. Perez and Numazawa are both directed to conserving battery power in mobile stations generally and more particularly at conserving battery power in mobile stations by using sensors to detect when the user of the mobile station is in a call and unlikely to be looking at the display (as when, for example, the proximity sensor detects the user’s ear by the mobile station) and to power off the display of mobile stations at such times. Perez at ¶ 0013 (“Referring to FIG. 1, a portable communication product 10 such as a cellular phone includes a transceiver radio having a microphone 20, an earpiece 22, a keypad 18 and a display 12 (such as a color display) coupled to the transceiver radio. The portable communication product 10 further includes at least one sensor (24, 26, 28 or 30) and a processor 16. The sensor can be used for detecting a user condition of the portable communication device such as a talk condition when the user is assumed to be talking on the portable communication device. The processor 16 can be programmed to at least reduce power provided to the display 12 when the sensor detects the talk condition. The processor 16 can also turn off power to the display 12 during a talk condition if desired.”); Numazawa at ¶ Abstract (“To achieve reduced power consumption through stopping operation of unnecessary functions during use of a wireless terminal. A CPU 2 identifies start of a call state through a signal from a signal processing portion 3 for controlling communication with a base station, and identifies, through an output signal from detecting means 6, whether or not a user ear is in contact with a terminal. Upon identification of contact of the ear to the terminal, controlling means 8 are caused to stop the supply of electric power, from a power supply 7, to displaying means 9 for providing information to a user, and lighting means 10, such as a black light.”), ¶ 0005-0007 (“In the present invention, control is such that, upon determination that the wireless terminal is in a call, operation of functions believe be unnecessary, due to the user of the terminal being in a call, is stopped, and upon termination of the call, operation of the stopped functions is restarted. Additionally, because it is envisioned that there will also be cases where, even during a call, the face of the user may be separated from the receiver of the terminal, control is performed so as to enable restarting of the operations of the functions that had been stopped as unnecessary, through detecting whether or not the user of the terminal has the receiver in contact with an ear. The achievement of reduced power consumption through stopping operation of functions that become unnecessary in use of the terminal, as described above, can be

	<p>anticipated to have the effect of extending the life of the power supply, such as a battery.’’). A person of ordinary skill in the art at the time of the alleged invention would be motivated to modify Perez to have “the proximity sensor is located proximate to the display” as disclosed in Numazawa to determine that the display is not visible because the user’s head is against it. The combination would constitute, at least, combining prior art elements according to known methods to yield predictable results, a simple substitution of one known element for another to obtain predictable results, the use of a known technique to improve similar devices in the same way, the application of a known technique to a known device ready for improvement to yield a predictable result, and obvious to try.</p>
<p>[Claim 8 – Preamble] 8. A method of conserving battery power in a mobile station, comprising:</p>	<p>To the extent the preamble is construed as limiting, Perez discloses a method of conserving battery power in a mobile station:</p> <p>For example: <i>see</i> discussion of claim 1, <i>supra</i>, which is incorporated herein by reference.</p>
<p>[8a] detecting whether an external object is proximate;</p>	<p>Perez discloses detecting whether an external object is proximate.</p> <p>For example: <i>see</i> discussion of claim element [1b], <i>supra</i>, which is incorporated herein by reference.</p> <p>To the extent Perez is deemed to not expressly or inherently disclose this claim element, Perez renders this claim element obvious to a person of skill in the art. <i>See</i> discussion of claim element [1b], <i>supra</i>, which is incorporated herein by reference.</p>
<p>[8b] determining whether a telephone call is active; and</p>	<p>Perez discloses determining whether a telephone call is active.</p> <p>For example: <i>see</i> discussion of claim element [1d], <i>supra</i>, which is incorporated herein by reference.</p>

<p>[8c] reducing power consumption of a display of the mobile station if (i) a telephone call is determined to be active and (ii) the proximity of the external object is detected; wherein:</p>	<p>Perez discloses reducing power consumption of a display of the mobile station if (i) a telephone call is determined to be active and (ii) the proximity of the external object is detected.</p> <p>For example: <i>see</i> discussion of claim elements [1f], [1h], <i>supra</i>, which are incorporated herein by reference.</p> <p>To the extent Perez is deemed to not expressly disclose this claim limitation, Perez inherently discloses this limitation. <i>See</i> discussion of claim element [1h], which is incorporated herein by reference.</p> <p>To the extent Perez is deemed to not expressly or inherently disclose this claim limitation, Perez renders it obvious to one of skill in the art at the time of the alleged invention. <i>See</i> discussion of claim element [1h], <i>supra</i>, which is incorporated herein by reference.</p> <p>To the extent Perez is deemed to not expressly or inherently disclose this claim element, it would be obvious to combine the disclosure of Perez with those of Fukiharu 598 as described in the Fukiharu 598 claim chart, which is incorporated herein in its entirety by reference. See discussion of claim element [1h], <i>supra</i>, which is incorporated herein by reference.</p> <p>To the extent Perez is deemed to not expressly or inherently disclose this claim element, it would be obvious to combine the disclosure of Perez with those of Numazawa as described in the Numazawa claim chart, which is incorporated herein in its entirety by reference. <i>See</i> discussion of claim element [1h], <i>supra</i>, which is incorporated herein by reference.</p> <p>To the extent Perez is deemed to not expressly or inherently disclose this claim element, it would be obvious to combine the disclosure of Perez with those of Miyashita as described in the Miyashita claim chart, which is incorporated herein in its entirety by reference. <i>See</i> discussion of claim element [1h], <i>supra</i>, which is incorporated herein by reference.</p>
<p>[8d] the telephone call is a wireless telephone call;</p>	<p>Perez discloses that the telephone call is a wireless telephone call.</p> <p>For example: <i>see</i> discussion of claim element [1g], <i>supra</i>, which is incorporated herein by reference.</p>

<p>[8e] the power consumption of the display is reduced while the proximity of the external object is detected only if the wireless telephone call is determined to be active; and</p>	<p>Perez discloses that the power consumption of the display is reduced while the proximity of the external object is detected only if the wireless telephone call is determined to be active.</p> <p>For example: <i>see</i> discussion of claim element [1f], <i>supra</i>, which is incorporated herein by reference.</p> <p>To the extent Perez is deemed to not expressly or inherently disclose this claim element, Perez renders this claim element obvious to a person of skill in the art. <i>See</i> discussion of claim element [1f], <i>supra</i>, which is incorporated herein by reference.</p>
<p>[8f] detecting whether an external object is proximate begins substantially concurrently with the mobile station initiating an outgoing wireless telephone call or receiving an incoming wireless telephone call.</p>	<p>Perez discloses that detecting whether an external object is proximate begins substantially concurrently with the mobile station initiating an outgoing wireless telephone call or receiving an incoming wireless telephone call.</p> <p>For example: <i>see</i> discussion of claim element [1i], <i>supra</i>, which is incorporated herein by reference.</p> <p>To the extent Perez is deemed to not expressly disclose this claim limitation, Perez inherently discloses this limitation. <i>See</i> discussion of claim element [1i], <i>supra</i>, which is incorporated herein by reference.</p> <p>To the extent Perez is deemed to not expressly or inherently disclose this claim limitation, Perez renders it obvious to one of skill in the art at the time of the alleged invention. <i>See</i> discussion of claim element [1i], <i>supra</i>, which is incorporated herein by reference.</p> <p>To the extent Perez is deemed to not expressly or inherently disclose this claim element, it would be obvious to combine the disclosure of Perez with those of Fukiharu 598 as described in the Fukiharu 598 claim chart, which is incorporated herein in its entirety by reference. <i>See</i> discussion of claim element [1i], <i>supra</i>, which is incorporated herein by reference.</p> <p>To the extent Perez is deemed to not expressly or inherently disclose this claim element, it would be obvious to combine the disclosure of Perez with those of Numazawa as described in the Numazawa claim chart, which is incorporated herein in its entirety by reference. <i>See</i> discussion of claim element [1i], <i>supra</i>, which is incorporated herein by reference.</p>

	<p>To the extent Perez is deemed to not expressly or inherently disclose this claim element, it would be obvious to combine the disclosure of Perez with those of Miyashita as described in the Miyashita claim chart, which is incorporated herein in its entirety by reference. <i>See</i> discussion of claim element [11], <i>supra</i>, which is incorporated herein by reference.</p>
<p>[Claim 12] The method as recited in claim 8, wherein the detecting of the proximity of the external object is performed by a mechanical proximity sensor, an optical sensor, or a range-detecting sensor.</p>	<p>Perez discloses that the detecting of the proximity of the external object is performed by a mechanical proximity sensor, an optical sensor, or a range-detecting sensor.</p> <p>For example: <i>see</i> discussion of claim 5, <i>supra</i>, which is incorporated herein by reference.</p> <p>To the extent Perez is deemed to not expressly disclose this claim limitation, Perez inherently discloses this limitation. <i>See</i> discussion of claim 5, <i>supra</i>, which is incorporated herein by reference.</p> <p>To the extent Perez is deemed to not expressly or inherently disclose this claim limitation, Perez renders it obvious to one of skill in the art at the time of the alleged invention. <i>See</i> discussion of claim 5, <i>supra</i>, which is incorporated herein by reference.</p> <p>To the extent Perez is deemed to not expressly or inherently disclose this claim element, it would be obvious to combine the disclosure of Perez with those of Fukiharu 598 as described in the Fukiharu 598 claim chart, which is incorporated herein in its entirety by reference. <i>See</i> discussion of claim element [1h], <i>supra</i>, which is incorporated herein by reference.</p> <p>To the extent Perez is deemed to not expressly or inherently disclose this claim element, it would be obvious to combine the disclosure of Perez with those of Numazawa as described in the Numazawa claim chart, which is incorporated herein in its entirety by reference. <i>See</i> discussion of claim 5, <i>supra</i>, which is incorporated herein by reference.</p>

Exhibit A6

**Exhibit A6 - Mantyjärvi
to Defendants' Preliminary Invalidation Contentions**

**Invalidation Chart for U.S. Patent No. 7,319,889
U.K. Patent Application No. 2,357,400 ("Mantyjärvi")**

U.K. Patent Application No. 2,357,400 to Mantyjärvi *et al.* ("Mantyjärvi") was filed on December 17, 1999 and published on June 20, 2001. Mantyjärvi is prior art to the '889 Patent under at least pre-AIA §§ 102(b), 102(e). Mantyjärvi anticipates or renders obvious, alone or in combination with other prior art references, each of the Asserted Claims of the '889 Patent as described in the chart below and in the main invalidity contentions document to which this chart is annexed.

It would have been obvious under 35 U.S.C. § 103 to a person having ordinary skill in the art at the time of the alleged invention to combine the teachings of Mantyjärvi with the following references:

1. Japanese Unexamined Patent Application Publication No. 2000-106598 to Fukiharu ("Fukiharu 598"). Fukiharu 598 qualifies as prior art under at least pre-AIA §§ 102(a), 102(b), and 102(e). Fukiharu 598 was published on April 11, 2000.

<u>Asserted Claims</u>	<u>Corresponding Disclosure in the Prior Art Reference(s)</u>
[Claim 1 – Preamble] 1. A mobile station, comprising:	<p>Mantyjärvi discloses a mobile station.</p> <p>For example: "In a communication system a terminal is used for providing a user interface for the user of the communication system. In other words, by means of the terminal the user may access and communicate over the communication system.</p> <p>An example of the terminal is a mobile station that may be used in a radio communication system. The mobile station is typically a portable hand-held device that provides, in cooperation with the radio communication system, mobility for the user. When the mobile station is not in use, it is usually positioned in the user's pocket or in a special case or similar. The mobile station typically comprises a keypad for controlling the operation thereof, such as for dialing in a desired telephone number and for controlling</p>

various functions of the mobile station. A mobile station is also typically provided with a display. The display may be used for showing various information to the user of the mobile station. Instead of being an entirely hand-held unit, a mobile station may also comprise separate units, such as a base transceiver unit and a separate handset portion and/or a separate headset portion.” Mantyjärvi at 1:10-29.

“For example, a mobile station may be provided with a keyboard lock referred to above. The basic idea of the keypad or keyboard lock is to prevent the user to mistakenly press any of the keys when this is not desired (e.g. when the mobile station is in the pocket of the user). For example, by means of the lock it is possible to prevent an accidental call establishment to a telephone number that is not actually selected. The keyboard lock may be controlled in alternative ways. According to one possibility predefined keys of the keypad can be used for locking and unlocking the keypad of the mobile station.” Mantyjärvi at 3:4-15.

“Figure 1 shows a mobile station in accordance with an embodiment of the present invention. The mobile station 1 comprises a housing or cover portion 11 which protects and encapsulates the various internal components of the mobile station. The internal components are not shown in greater detail, but may typically comprise components such as a processor 12 that is for controlling one or several functions of the mobile station.” Mantyjärvi at 6:10-16.

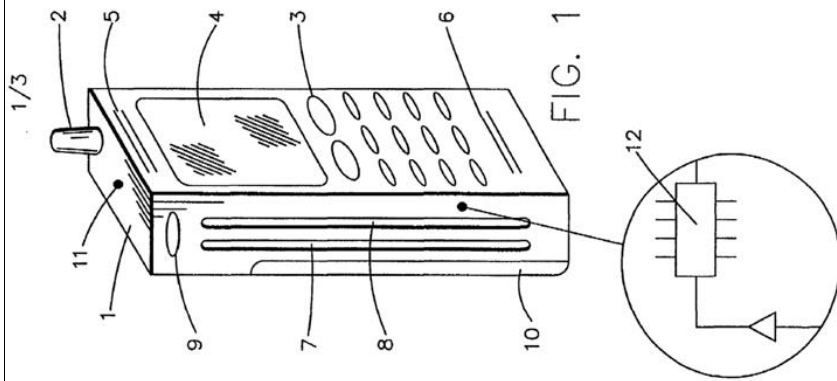

Mantjarvi at Fig. 1.

“26. A terminal according to any of the preceding claims, wherein the terminal comprises a mobile station of a radio communication system.” Mantjarvi at Claim 26.

[1a] a display;

Mantjarvi discloses a display.

For example:

“A mobile station is also typically provided with a display. The display may be used for showing various information to the user of the mobile station. Instead of being an entirely hand-held unit, a mobile station may also comprise separate units, such as a base transceiver unit and a separate handset portion and/or a separate headset portion.”
Mantyjärvi at 1:24-29.

“Similarly, any other functions of the terminal may be controlled by pressing appropriate keys or moving one or several components of the terminal to operate an associated switch. The functions and/or operations that need to be controlled may be functions such as switching the terminal between different modes of operation, controlling a keyboard lock or display of the terminal, switching on/off the lighting of the keyboard or the display, or controlling any other special features of the terminal or services provided for the user of the terminal (such as voice mail, short text messages, calendar or alarm functions and so on).” Mantyjärvi at 2:25-3:2.

“The mobile station 1 comprises also a display 4. The display may be used for displaying various messages and information to the user. The user may also use the display for the control operations of the mobile station, e.g. such that the user uses the keys 3 for the selection of an appropriate function from a menu displayed to him by the display 4.”
Mantyjärvi at 7:4-9.

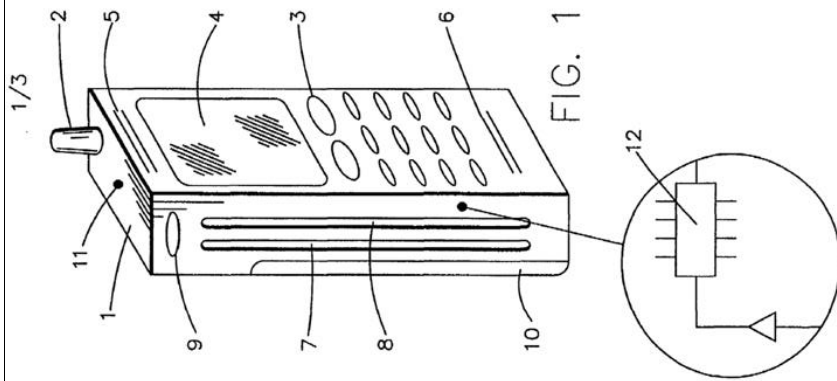

Mantjarvi at Fig. 1.

“A terminal according to any of the preceding claims, wherein the operation of a display of the terminal is controlled based on the signal from the detector means.” Mantjarvi at Claim 8.

[1b] a proximity sensor adapted to generate a signal indicative of proximity of an external object; and

Mantjarvi discloses a proximity sensor adapted to generate a signal indicative of proximity of an external object.

For example:

“According to one aspect of the present invention, there is provided a terminal for a communication system, the terminal comprising detector means that are arranged to detect a contact between at least one surface of the terminal and the skin of the user of the terminal, wherein at least one function of the terminal is controlled based on a signal from the detecting means.

The detector means may comprise a first detector arrangement and a second detector arrangement, wherein said first and second detector arrangements are based on different principles of detecting a contact between the terminal and the skin of the user. The control of the terminal that is based on the signal from the detector means is preferably provided only if said first and second detector arrangements both output a signal that indicates a contact between the terminal and the skin of the user.

According to one aspect of the present invention, there is provided a detector arrangement for a terminal of a communication system, the terminal comprising at least one element that is to be held against the skin of the user of the terminal, the detector arrangement comprising circuitry for generating an output signal whenever a surface of the terminal touches in a predefined manner the skin of the user, wherein the output signal is arranged to be employed in the control of at least one function of the terminal.

According to another aspect of the present invention, there is provided a method for providing control of at least one function of a terminal of a communication system, comprising the steps of:

detecting a contact between a surface of the terminal and the skin of the user of the terminal; generating an output signal indicating a contact between the surface of the terminal and the skin of the user; and controlling said at least one function of the terminal based on the output signal.” Mantjarvi at 4:4-5:10.

“Two strip electrodes 7 and 8 are attached on one side of the station 1. The electrodes 7 and 8 are employed for detecting a contact between the skin of the user and the mobile station. According to a possibility the electrodes 7 and 8 are attached on the outer surface of the housing 11 of the mobile station 1. The electrodes may also be embedded in the

cover material such that the surface of the electrodes will remain visible and may thus be touched by the skin of the user.

More particularly, the electrodes 7 and 8 may be arranged to measure so called galvanic skin response (GSR). Figure 2 discloses a block diagram for circuitry that may be used when implementing a galvanic skin response touch sensing arrangement 20. The first electrode 7 is coupled to a voltage source V_{cc} via a line 27. The voltage V_{cc} may equal the operational voltage of the mobile station, but V_{cc} may also be different from that. Voltage V_{cc} is preferably provided by the battery 10 of the mobile station 1. A buffer 21 and an appropriate impedance 24 8 may be provided for scaling the current and voltage on the line 27 between the electrode 7 and the voltage source V_{cc} . The second electrode 8 is coupled to an output 26 of the circuitry 20. The signal from the electrode 8 may be amplified by an amplifier 23 before the signal is output from the circuitry 20. The amplifier circuit may comprise a resistor/ impedance 25.

The galvanic skin response (GSR) detection method is based on provision of a conductive path between two or more electrodes. When the user grips the mobile station 1 by his hand (not shown), the skin of the hand will provide the conductive path between the electrodes 7 and 8 of Figures 1 and 2. Now, when a conductive path is provided between the electrodes 7 and 8, the voltage and current at the output line 26 will change in accordance with known principles. The GSR sensing arrangement 20 gives typically so-called TTL level (transistor to transistor logic level) output signal when the conductive material is in touch with at last two of the electrodes. A component 22 may be used for setting an appropriate threshold level for the conductivity, i.e. the component 22 may trigger the circuitry 20 to output a signal that indicates a contact between the hand of the user and the mobile station 1.” Mantiyarvi at 7:14-8:22.

“As illustrated by the flow chart of figure 6, the output signal on line 26 may be used in the control of a function of the mobile station. For example, activation of a mobile station that is in a standby mode may be based on the output signal from the sensing arrangement. The activation of the mobile station may be triggered by the control unit 12 of the mobile station based on a received TTL level signal output 26 from the GSR arrangement 20. The station may be correspondingly deactivated i.e. returned 9 to the

standby mode after the control unit no longer receives the TTL level signal. An automated keyboard lock may function in a corresponding manner, i.e. the keyboard may be unlocked only when the GSR detecting arrangement outputs a TTL level signal.

The station may also be switched between different modes of operation or even on and off based on the output signal received from the detecting means. The lighting of the keypad and/or the display may be controlled based on this information. According to an example, a vibrating alarm arrangement of the mobile station is controlled such that no sound alarm is provided when the mobile station is detected to be in contact with the skin of the user, while a sound alarm will be provided when the mobile station (or any part or accessory thereof) is not in direct contact with the skin of the user. It is to be noted that the above functions described in the context of a mobile station are only examples and that the embodiments of the present invention may be employed when controlling any function of a communications terminal. It is also noted that the output signal from the detector arrangement may indicate a "positive" or "negative" contact. In other words, a signal may be outputted only when the terminal is in contact with the skin of the user or alternatively only when there is no contact between the user and the terminal." Mäntyjärvi at 8:24-9:24.

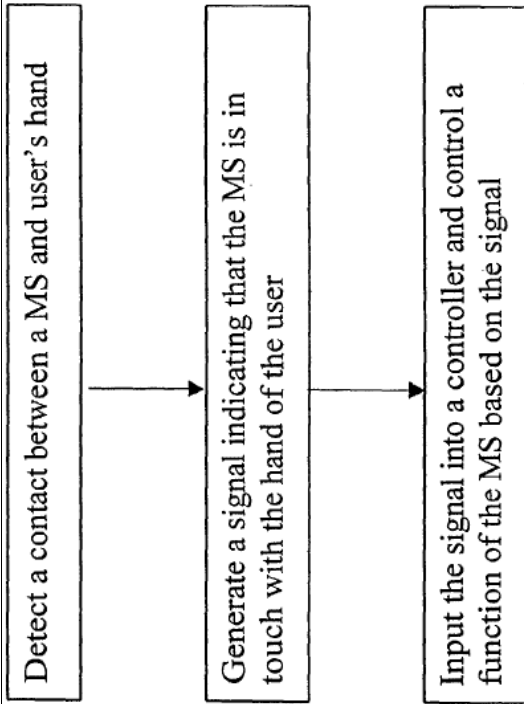

FIG. 6

Mantjarvi at Fig. 6.

“Another possibility for measuring the presence of the living tissue in touch or in close proximity with the terminal is so called capacitive proximity (CP) sensor. The capacitive proximity sensor requires only one electrode, even though it is possible to use several CP sensors. The CP based system can be adjusted to sense the proximity of the living tissue, for example such that a CP sensing arrangement will react when the distance between the skin of the user and the mobile station is within a range of 0 to 5 mm. The capacitive proximity sensors may be arranged to be sensitive only for living tissue, and will thus not react to other materials. When the capacitive proximity sensor senses a living tissue, it may output an appropriate signal, such as a TTL level signal. The use of the TTL level output signal in accordance with the invention was already discussed above.

Figure 4 shows a schematic block diagram for a detection circuitry 31 based on the capacitive proximity sensor detection. In general, the circuitry 31 can be defined as

oscillating circuitry that is implemented by means of a flip-flop switch 32. The circuitry 31 is provided with suitable triggering means 33, such as a Schmitt trigger. An inverting amplifier 34 may also be provided on the output line 35. The circuitry operates such that when the capacitive sensor 30 is touched by a living tissue, the output on line 35 will rise in the V_{cc} level, thus providing a signal indicating that the terminal is in touch with living tissue.

The capacitive proximity sensor may also detect a living tissue, such as the skin of the user, that is not in an direct contact with the sensors. The skin may be, for example, within a distance that is up to 5 mm from the sensing electrode. Therefore the capacitive proximity electrode 30 may be placed on the internal surface of the cover material of the terminal 1 or may be embedded within the cover material of the terminal 1. For example, it could be placed inside the cover of the battery 10 of the mobile terminal 1.” Mantyjärvi at 10:20-11:25.

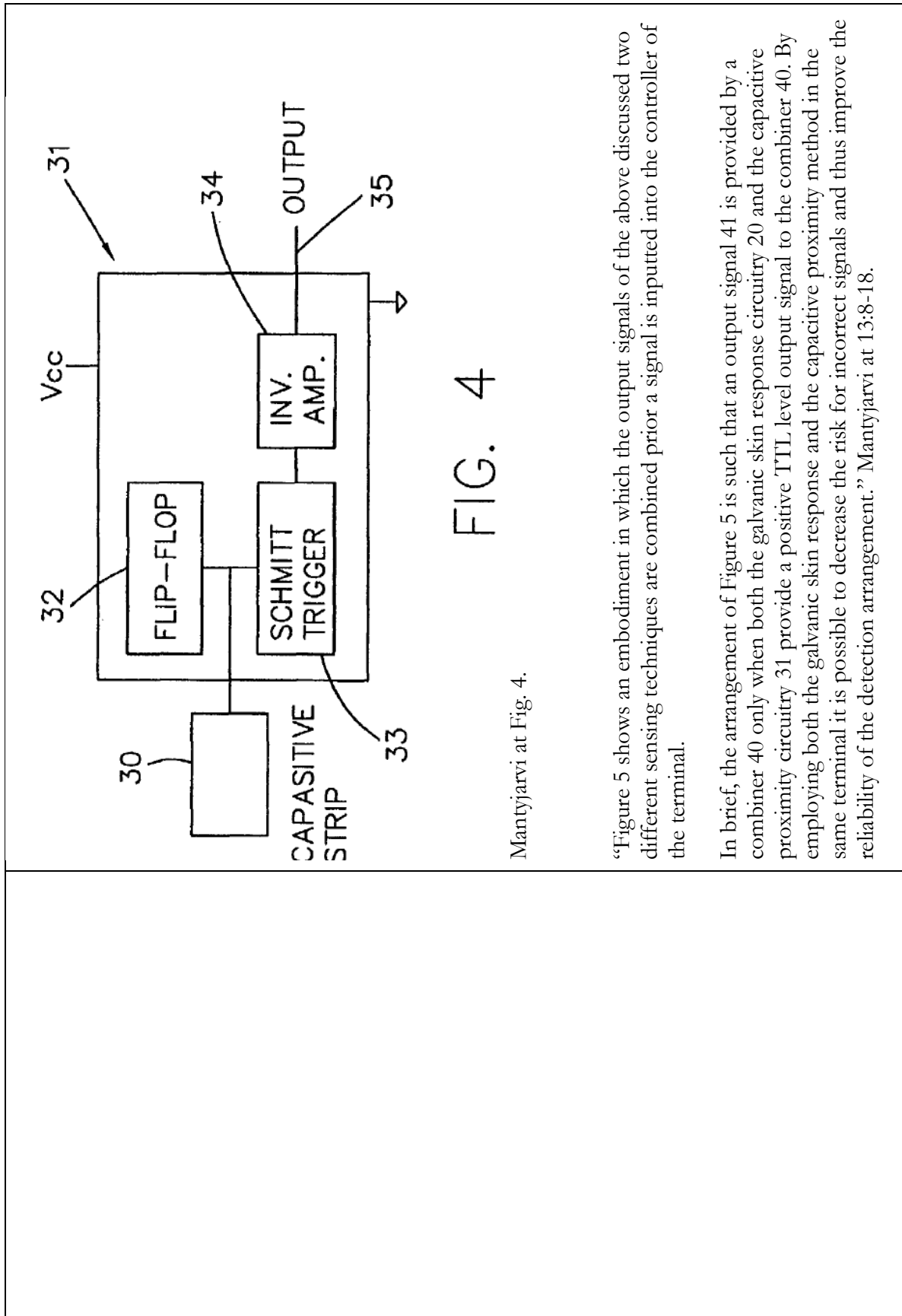

FIG. 4

Mantjarvi at Fig. 4.

“Figure 5 shows an embodiment in which the output signals of the above discussed two different sensing techniques are combined prior a signal is inputted into the controller of the terminal.

In brief, the arrangement of Figure 5 is such that an output signal 41 is provided by a combiner 40 only when both the galvanic skin response circuitry 20 and the capacitive proximity circuitry 31 provide a positive TTL level output signal to the combiner 40. By employing both the galvanic skin response and the capacitive proximity method in the same terminal it is possible to decrease the risk for incorrect signals and thus improve the reliability of the detection arrangement.” Mantjarvi at 13:8-18.

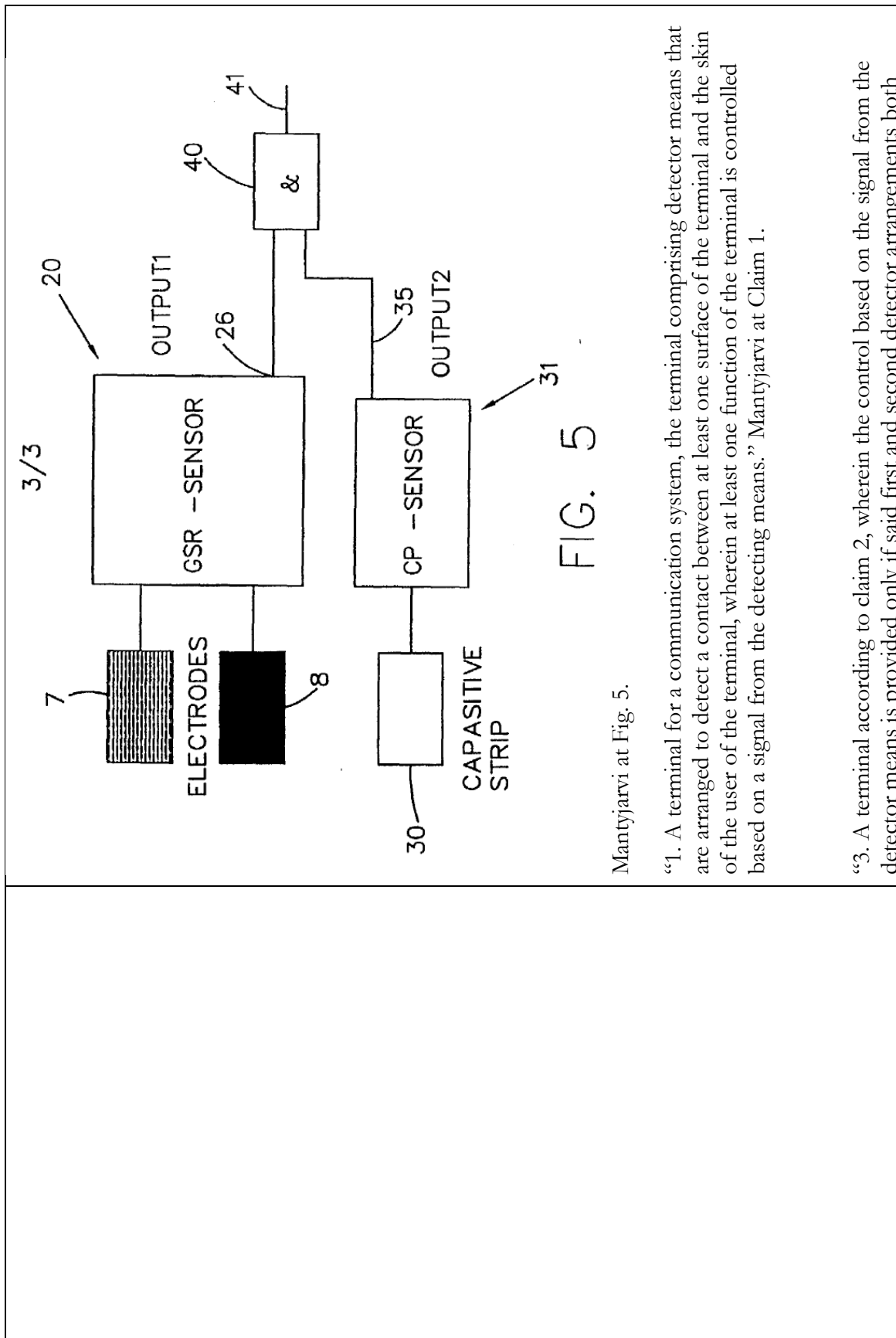

FIG. 5

Mantjarvi at Fig. 5.

“1. A terminal for a communication system, the terminal comprising detector means that are arranged to detect a contact between at least one surface of the terminal and the skin of the user of the terminal, wherein at least one function of the terminal is controlled based on a signal from the detecting means.” Mantjarvi at Claim 1.

“3. A terminal according to claim 2, wherein the control based on the signal from the detector means is provided only if said first and second detector arrangements both

	<p>output a signal that indicates a contact between the terminal and the skin of the user.” Mantjarvi at Claim 3.</p> <p>“16. A terminal according to any of the preceding claims, wherein the detector means comprise a capacitive proximity sensor.” Mantjarvi at Claim 16.</p> <p>“27. A detector arrangement for a terminal of a communication system, the terminal comprising at least one element that is to be held against the skin of the user of the terminal, the detector arrangement comprising circuitry for generating an output signal whenever a surface of the terminal touches in a predefined manner the skin of the user, wherein the output signal is arranged to be employed in the control of at least one function of the terminal.” Mantjarvi at Claim 27.</p>
<p>[1c] a microprocessor adapted to:</p>	<p>Mantjarvi discloses a microprocessor.</p> <p>For example:</p> <p>“Figure 1 shows a mobile station in accordance with an embodiment of the present invention. The mobile station 1 comprises a housing or cover portion 11 which protects and encapsulates the various internal components of the mobile station. The internal components are not shown in greater detail, but may typically comprise components such as a processor 12 that is for controlling one or several functions of the mobile station.” Mantjarvi at 6:10-16.</p>

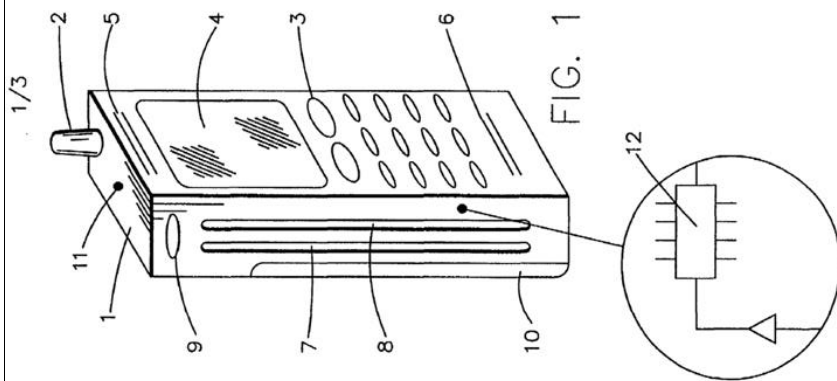

Mantjarvi at Fig. 1.

“As illustrated by the flow chart of figure 6, the output signal on line 26 may be used in the control of a function of the mobile station. For example, activation of a mobile station that is in a standby mode may be based on the output signal from the sensing arrangement. The activation of the mobile station may be triggered by the control unit 12 of the mobile station based on 30 a received TTL level signal output 26 from the GSR arrangement 20.” Mantjarvi at 8:24-31.

	<p>“In addition, the sensitivity of the control unit of the mobile station can be adjusted in accordance with specific requirements and/or conditions and may vary if the requirements and/or conditions change.” Mantjarvi at 14:13-16.</p>
<p>[1d] (a) determine whether a telephone call is active;</p>	<p>Mantjarvi discloses the microprocessor adapted to determine whether a telephone call is active.</p> <p>For example: “An example of the terminal is a mobile station that may be used in a radio communication system. The mobile station is typically a portable hand-held device that provides, in cooperation with the radio communication system, mobility for the user. When the mobile station is not in use, it is usually positioned in the user’s pocket or in a special case or similar. The mobile station typically comprises a keypad for controlling the operation thereof, such as for dialing in a desired telephone number and for controlling various functions of the mobile station.” Mantjarvi at 1:15-24.</p> <p>“The user typically controls the operation and/or functions of the terminal by pressing appropriate buttons on a keyboard of the terminal or by lifting the handset off-hook/placing the handset on-hook or opening/closing a specific cover connected to a switch and so on. Voice activated control systems are also known. For example, when the user wishes to establish a call, he usually selects or fetches the desired destination number by pressing appropriate keys on the keyboard or he may use possible voice activation functions of the terminal. When the user receives a call, the call is typically answered by lifting the handset off-hook, or by pressing at least one key of the key board or by opening the special cover of the keyboard.</p> <p>Similarly, any other functions of the terminal may be controlled by pressing appropriate keys or moving one or several components of the terminal to operate an associated</p>

switch. The functions and/or operations that need to be controlled may be functions such as switching the terminal between different modes of operation, controlling a keyboard lock or display of the terminal, switching on/off the lighting of the keyboard or the display, or controlling any other special features of the terminal or services provided for the user of the terminal (such as voice mail, short text messages, calendar or alarm functions and so on).

For example, a mobile station may be provided with a keyboard lock referred to above. The basic idea of the keypad or keyboard lock is to prevent the user to mistakenly press any of the keys when this is not desired (e.g. when the mobile station is in the pocket of the user). For example, by means of the lock it is possible to prevent an accidental call establishment to a telephone number that is not actually selected. The keyboard lock may be controlled in alternative ways. According to one possibility predefined keys of the keypad can be used for locking and unlocking the keypad of the mobile station.”
Mantyjärvi at 2:11-3:15.

“Figure 1 shows a mobile station in accordance with an embodiment of the present invention. The mobile station 1 comprises a housing or cover portion 11 which protects and encapsulates the various internal components of the mobile station. The internal components are not shown in greater detail, but may typically comprise components such as a processor 12 that is for controlling one or several functions of the mobile station.

The mobile station 1 also comprises transceiver means (not shown) for receiving and transmitting a radio signal through an antenna 2, possible circuit boards, lightning components and other internal components known in the art. The cover or housing 11 is usually of plastic material, but other materials may also be used.

The terminal 1 comprises further a keypad 3. The keypad typically comprises several buttons such as "on-hook" and "off hook" keys (sometimes referred to as "yes" and "no" keys) and keys for numerals from zero to nine. The keys can also be used for typing in alphabetic characters, such as for typing in short text messages and inputting names and numbers into a telephone number memory and/or entries into diaries or other special 7

functions provided by the mobile terminal. The mobile station 1 may also comprise a separate power switch 9." Mantjarvi at 6:10-22.

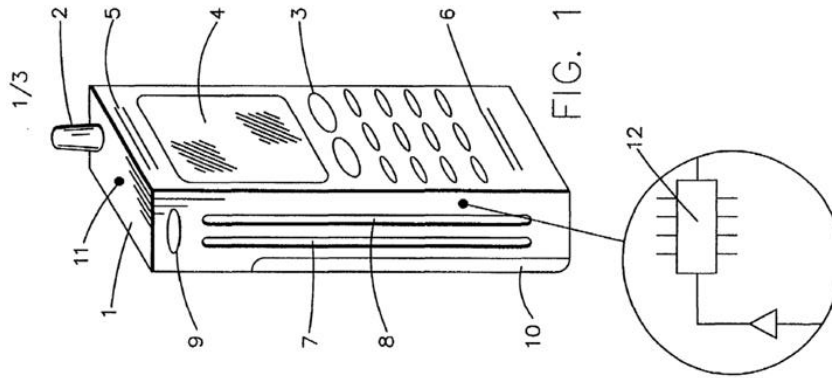

Mantjarvi at Fig. 1.

"The controller may provide different instructions for the controlled functions depending on the location or the context where the control is provided. For example, during

a normal speech call the lighting of the display and/or keyboard may be switched off after a predefined time has lapsed from the activation thereof. However, the lighting will stay on if the connection was established for data communication, such as for a wireless application protocol (WAP) connection or for an Internet connection.” Mantyjärvi at 14:21-30.

“Therefore a verification of the detection result of a detection arrangement may be desirable in some applications. The verification can be provided by employing more than one sensing technique in the generation of the output signal to make sure that the terminal is indeed in the hand of the user or against the cheek or ear of the user.” Mantyjärvi at 13:2-6.

“4. A terminal according to any of the preceding claims comprising a controller for controlling said at least one function of the terminal.” Mantyjärvi at Claim 4.

“5. A terminal according to any of the preceding claims, wherein switching between different modes of operation of the terminal is arranged to be triggered based on the signal from the detector means.” Mantyjärvi at Claim 5.

“24. A terminal according to any of the preceding claims, wherein the control of the function is based, in addition to the signal from the detector means, on at least one of the following: the operational status of the terminal; the location of the terminal; the time of the day; the time of the year; temperature; the type of the communication.” Mantyjärvi at Claim 24.

“26. A terminal according to any of the preceding claims, wherein the terminal comprises a mobile station of a radio communication system.” Mantiyarvi at Claim 26.

“31. A method according to claim 30, wherein the generation of the output signal comprises further steps of:

receiving a first signal from a first detector arrangement; 21 receiving a second signal from a second detector arrangement that is different from the operation principles thereof from the first detector arrangement; verifying the first and second signals; and generating the output signal if said first and second signals indicate similar results of detection.” Mantiyarvi at Claim 31.

To the extent Mantiyarvi is deemed to not expressly disclose the microprocessor adapted to “determine whether a telephone call is active,” Mantiyarvi inherently discloses this limitation. In Mantiyarvi, “during a normal speech call the lighting of the display and/or keyboard may be switched off after a predefined time has lapsed from the activation thereof.” Mantiyarvi at 14:24-26. A person of ordinary skill in the art at the time of the alleged invention would understand that in order for the mobile station in Mantiyarvi to “switch[] off” the “lighting of the display” “during a normal speech call,” the mobile station would necessarily need to determine when a “normal speech call” is ongoing and therefore “whether a telephone call is active.” Mantiyarvi also discloses “a processor 12 that is for controlling one or several functions of the mobile station.” Mantiyarvi at 6:15-16. A person of ordinary skill in the art at the time of the alleged invention would understand that the processor 12 of Mantiyarvi would control the function of determining whether a “normal speech call” is ongoing. Therefore a person of ordinary skill in the art at the time of the alleged invention would understand Mantiyarvi to necessarily disclose a microprocessor adapted to “determine whether a telephone call is active.”

To the extent Mantjarvi is deemed to not expressly or inherently disclose the microprocessor adapted to “determine whether a telephone call is active,” Mantjarvi renders this limitation obvious to one of skill in the art to “determine whether a telephone call is active.” A person of skill in the art would understand that in order for the mobile station in Mantjarvi to “switch[] off” the “lighting of the display” “during a normal speech call,” the mobile station would need to determine when a “normal speech call” is ongoing and therefore “whether a telephone call is active.” A person of ordinary skill in the art at the time of the alleged invention would find it obvious to implement the microprocessor of Mantjarvi to determine whether a “normal speech call is ongoing.” Doing so would be a design choice driven by a number of different reasons, including that it would support Mantjarvi’s ability to conserve battery power in mobile stations. Doing so would further support Mantjarvi’s ability to provide means for “controlling of at least one function of a terminal of a communication system” (Mantjarvi at 1:5-6) where the “sensitivity of the control unit of the mobile station can be adjusted in accordance with specific requirements and/or conditions and may vary if the requirements and/or conditions change.” Mantjarvi at 14:13-16. Doing so would be within the knowledge and ability of a person of ordinary skill in the art at the time of the alleged invention. Doing so would also constitute, at least, combining prior art elements according to known methods to yield predictable results, a simple substitution of one known element for another to obtain predictable results, the use of a known technique to improve similar devices in the same way, the application of a known technique to a known device ready for improvement to yield a predictable result, and obvious to try.

To the extent Mantjarvi is deemed to not expressly or inherently disclose a microprocessor adapted to “determine whether a telephone call is active,” it would be obvious to combine the disclosure of Mantjarvi with those of Fukiharu 598 as described in the Fukiharu 598 claim chart, which is incorporated herein in its entirety by reference. Mantjarvi and Fukiharu 598 are both directed to controlling the functionality of mobile stations based in part on signals from a proximity sensor. *See, e.g.*, Mantjarvi at 3:30-4:2 (“It is an aim of the embodiments of the present invention to address one or several of the disadvantages of the prior art terminals and to provide a new type of solution for controlling one or several functions of a terminal.”); Fukiharu 598 at Abstract (“The

object of the present invention is to provide a mobile telephone with a lighting device, and a method for controlling said lighting device, with improved portability through reducing the weight and volume of the battery, and to enable a thorough increase in talk time and standby time, through controlling, through a touch sensor that is provided on a receiver portion surface of the mobile telephone, operation of a lighting device (backlight) of a liquid crystal display device and/or a key pad portion.”). More particularly both Mantyjärvi and Fukiharu 598 disclose turning off the display of a mobile station based on signals from a proximity sensor indicating that a user’s face or ear is in close proximity to the mobile station. *See, e.g.*, Mantyjärvi at Claim 1 (“A terminal for a communication system, the terminal comprising detector means that are arranged to detect a contact between at least one surface of the terminal and the skin of the user of the terminal, wherein at least one function of the terminal is controlled based on a signal from the detecting means.”), Mantyjärvi at Claim 8 (“A terminal according to any of the preceding claims, wherein the operation of a display of the terminal is controlled based on the signal from the detector means.”), Mantyjärvi at Claim 11 (“A terminal according to any of the preceding claims, wherein the detector means are arranged to sense a contact between the terminal and the cheek and/or ear of the user.”); Fukiharu 598 at ¶0015 (“At this time, the lighting-ON state is maintained if not in the voice communication mode. If in the voice communication mode, a touch sensor 2c is placed into an operating state by a signal from the controlling portion 2a, and constantly outputs a detection output to the controlling portion 2a. If the touch sensor 2c contacts a portion of the human body, such as an ear, a lighting-OFF signal is outputted to the lighting device ON/OFF circuit portion 2b from the controlling portion 2a through the ON output of the touch sensor 2c, and the power supplies to both the lighting device (backlight) 3a and the lighting device (backlight) 4a go to the OFF state, and this lighting-OFF state is maintained until the touch sensor 2c goes into a non-contact state.”). A person of ordinary skill in the art at the time of the alleged invention would therefore understand that both Mantyjärvi and Fukiharu 598 disclose ways of conserving battery power by shutting of the display of a mobile station at such times that the user of the mobile station is unlikely to be looking at the display (as indicated by at least a proximity sensor). A person of ordinary skill in the art at the time of the alleged invention would be therefore be motivated to modify Mantyjärvi to use a microprocessor adapted to “determine whether a telephone call is active,” as disclosed in Fukiharu 598 for a number of different reasons, including that it would support Mantyjärvi’s ability to conserve

	<p>battery power in mobile stations. Doing so would further support Mantiyarvi's ability to provide means for "controlling of at least one function of a terminal of a communication system" (Mantiyarvi at 1:5-6) where the "sensitivity of the control unit of the mobile station can be adjusted in accordance with specific requirements and/or conditions and may vary if the requirements and/or conditions change." Mantiyarvi at 14:13-16. Doing so would be within the knowledge and ability of a person of ordinary skill in the art at the time of the alleged invention. The combination would constitute, at least, combining prior art elements according to known methods to yield predictable results, a simple substitution of one known element for another to obtain predictable results, the use of a known technique to improve similar devices in the same way, the application of a known technique to a known device ready for improvement to yield a predictable result, and obvious to try.</p>
<p>[1e] (b) receive the signal from the proximity sensor; and</p>	<p>Mantiyarvi discloses the microprocessor adapted to receive the signal from the proximity sensor.</p> <p>For example:</p> <p>"The present invention relates to a terminal for a communication system. The terminal includes detector means 7, 8 that are arranged to detect a contact between at least one surface of the terminal and the skin of the user. At least one function of the terminal is arranged to be controlled based on a signal generated by the detecting means in response to the detection. The sensor may be resistive, sensing galvanic skin resistance across linear contacts 7, 8 or could be a capacitive proximity sensor, or may be pressure sensitive." Mantiyarvi at Abstract.</p> <p>"According to one aspect of the present invention, there is provided a terminal for a communication system, the terminal comprising detector means that are arranged to detect a contact between at least one surface of the terminal and the skin of the user of</p>

the terminal, wherein at least one function of the terminal is controlled based on a signal from the detecting means.

The detector means may comprise a first detector arrangement and a second detector arrangement, wherein said first and second detector arrangements are based on different principles of detecting a contact between the terminal and the skin of the user. The control of the terminal that is based on the signal from the detector means is preferably provided only if said first and second detector arrangements both output a signal that indicates a contact between the terminal and the skin of the user.

According to one aspect of the present invention, there is provided a detector arrangement for a terminal of a communication system, the terminal comprising at least one element that is to be held against the skin of the user of the terminal, the detector arrangement comprising circuitry for generating an output signal whenever a surface of the terminal touches in a predefined manner the skin of the user, wherein the output signal is arranged to be employed in the control of at least one function of the terminal.

According to another aspect of the present invention, there is provided a method for providing control of at least one function of a terminal of a communication system, comprising the steps of:

detecting a contact between a surface of the terminal and the skin of the user of the terminal; generating an output signal indicating a contact between the surface of the terminal and the skin of the user; and controlling said at least one function of the terminal based on the output signal.” Mantyjärvi at 4:4-5:10.

“Two strip electrodes 7 and 8 are attached on one side of the station 1. The electrodes 7 and 8 are employed for detecting a contact between the skin of the user and the mobile station.

According to a possibility the electrodes 7 and 8 are attached on the outer surface of the housing 11 of the mobile station 1.

The electrodes may also be embedded in the cover material such that the surface of the electrodes will remain visible and may thus be touched by the skin of the user.

More particularly, the electrodes 7 and 8 may be arranged to measure so called galvanic skin response (GSR). Figure 2 discloses a block diagram for circuitry that may be used when implementing a galvanic skin response touch sensing arrangement 20. The first electrode 7 is coupled to a voltage source V_{cc} via a line 27. The voltage V_{cc} may equal the operational voltage of the mobile station, but V_{cc} may also be different from that.

Voltage V_{cc} is preferably provided by the battery 10 of the mobile station 1. A buffer 21 and an appropriate impedance 24 8 may be provided for scaling the current and voltage on the line 27 between the electrode 7 and the voltage source V_{cc} . The second electrode 8 is coupled to an output 26 of the circuitry 20. The signal from the electrode 8 may be amplified by an amplifier 23 before the signal is output from the circuitry 20.

The amplifier circuit may comprise a resistor/ impedance 25. The galvanic skin response (GRS) detection method is based on provision of a conductive path between two or more electrodes.

When the user grips the mobile station 1 by his hand (not shown), the skin of the hand will provide the conductive path between the electrodes 7 and 8 of Figures 1 and 2. Now, when a conductive path is provided between the electrodes 7 and 8, the voltage and current at the output line 26 will change in accordance with known principles. The GSR sensing arrangement 20 gives typically so-called TTL level (transistor to transistor logic level) output signal when the conductive material is in touch with at least two of the electrodes. A component 22 may be used for setting an appropriate threshold level for the conductivity, i.e. the component 22 may trigger the circuitry 20 to output a signal that indicates a contact between the hand of the user and the mobile station 1.

As illustrated by the flow chart of figure 6, the output signal on line 26 may be used in the control of a function of the mobile station. For example, activation of a mobile station that is in a standby mode may be based on the output signal from the sensing arrangement. The activation of the mobile station may be triggered by the control unit 12 of the mobile station based on a received TTL level signal output 26 from the GSR arrangement 20. The station may be correspondingly deactivated i.e. returned 9 to the

standby mode after the control unit no longer receives the TTL level signal. An automated keyboard lock may function in a corresponding manner, i.e. the keyboard may be unlocked only when the GSR detecting arrangement outputs a TTL level signal. The station may also be switched between different modes of operation or even on and off based on the output signal received from the detecting means.” Mäntylä at 7:14-9:8.

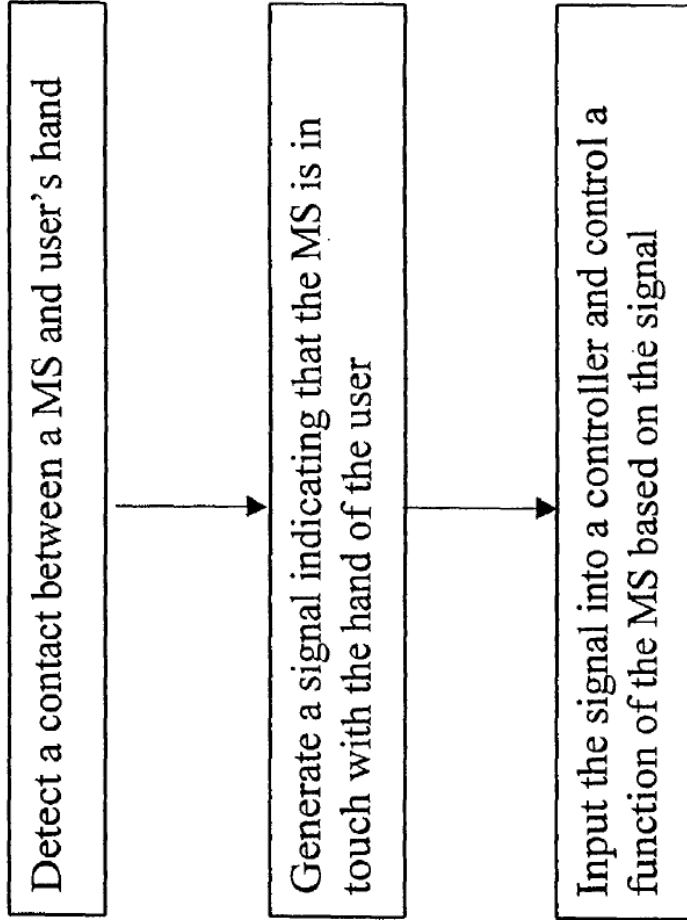

FIG. 6

Mäntylä at Fig. 6.

“It is also noted that the output signal from the detector arrangement may indicate a "positive" or "negative" contact. In other words, a signal may be outputted only when the terminal is in contact with the skin of the user or alternatively only when there is no contact between the user and the terminal.” Mantjarvi at 9:18-23.

“When the capacitive proximity sensor senses a living tissue, it may output an appropriate signal, such as a TTL level signal.” Mantjarvi at 10:30-11:1.

“Figure 4 shows a schematic block diagram for a detection circuitry 31 based on the capacitive proximity sensor detection.

In general, the circuitry 31 can be defined as oscillating circuitry that is implemented by means of a flip-flop switch 32.

The circuitry 31 is provided with suitable triggering means 33, such as a Schmitt trigger. An inverting amplifier 34 may also be provided on the output line 35. The circuitry operates such that when the capacitive sensor 30 is touched by a living tissue, the output on line 35 will rise in the Vcc level, thus providing a signal indicating that the terminal is in touch with living tissue.

The capacitive proximity sensor may also detect a living tissue, such as the skin of the user, that is not in an direct contact with the sensors. The skin may be, for example, within a distance that is up to 5 mm from the sensing electrode.

Therefore the capacitive proximity electrode 30 may be placed on the internal surface of the cover material of the terminal 1 or may be embedded within the cover material of the terminal 1. For example, it could be placed inside the cover of the battery 10 of the mobile terminal 1.” Mantjarvi at 11:5-25.

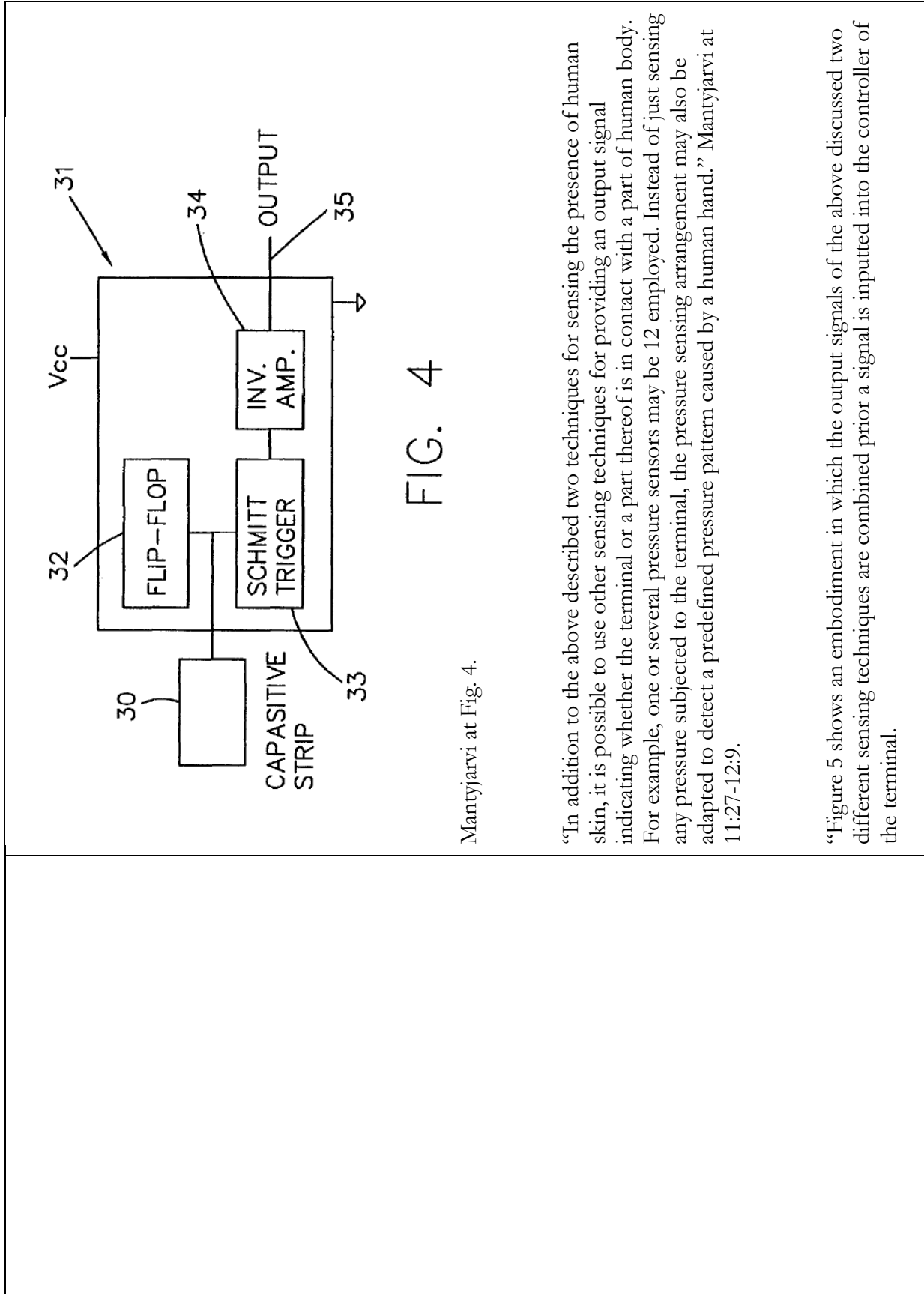

Mantjarvi at Fig. 4.

FIG. 4

“In addition to the above described two techniques for sensing the presence of human skin, it is possible to use other sensing techniques for providing an output signal indicating whether the terminal or a part thereof is in contact with a part of human body. For example, one or several pressure sensors may be 12 employed. Instead of just sensing any pressure subjected to the terminal, the pressure sensing arrangement may also be adapted to detect a predefined pressure pattern caused by a human hand.” Mantjarvi at 11:27-12:9.

“Figure 5 shows an embodiment in which the output signals of the above discussed two different sensing techniques are combined prior a signal is inputted into the controller of the terminal.

In brief, the arrangement of Figure 5 is such that an output signal 41 is provided by a combiner 40 only when both the galvanic skin response circuitry 20 and the capacitive proximity circuitry 31 provide a positive TTL level output signal to the combiner 40. By employing both the galvanic skin response and the capacitive proximity method in the same terminal it is possible to decrease the risk for incorrect signals and thus improve the reliability of the detection arrangement.” Mantyjarvi at 13:8-18.

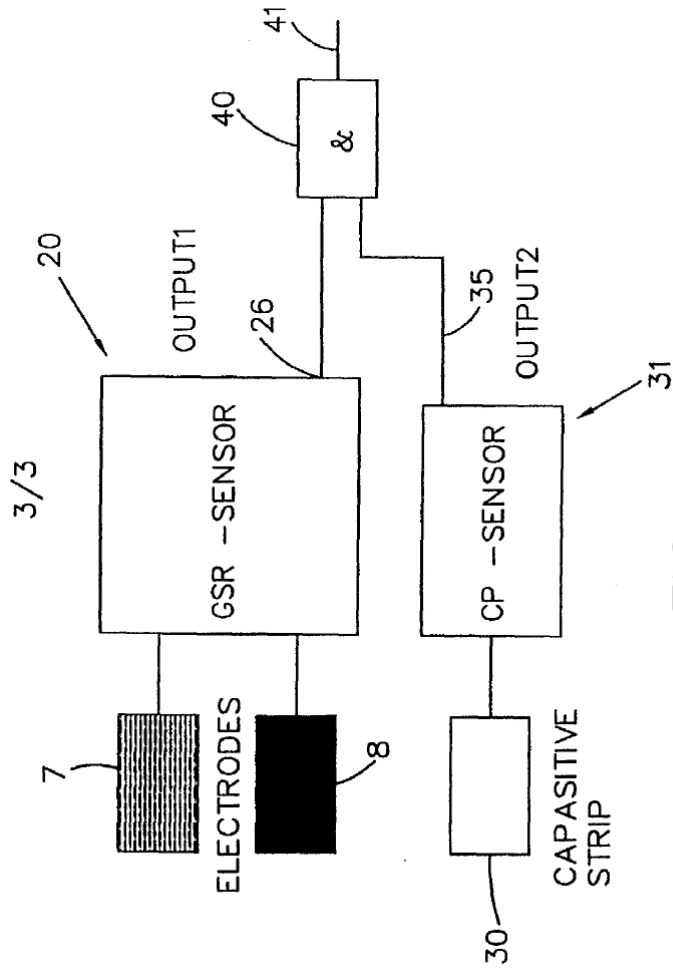

FIG. 5

Mantyjarvi at Fig. 5.

“ 3. A terminal according to claim 2, wherein the control based on the signal from the detector means is provided only if said first and second detector arrangements both

	<p>output a signal that indicates a contact between the terminal and the skin of the user.” Mantyjarvi at Claim 3.</p> <p>“30. A method for providing control of at least one function of a terminal of a communication system, comprising the steps of:</p> <p>detecting a contact between a surface of the terminal and the skin of the user of the terminal; generating an output signal indicating a contact between the surface of the terminal and the skin of the user; and controlling said at least one function of the terminal based on the output signal.</p> <p>31. A method according to claim 30, wherein the generation of the output signal comprises further steps of:</p> <p>receiving a first signal from a first detector arrangement; 21 receiving a second signal from a second detector arrangement that is different from the operation principles thereof from the first detector arrangement; verifying the first and second signals; and generating the output signal if said first and second signals indicate similar results of detection.” Mantyjarvi at Claims 30-31.</p>
<p>[1f] (c) reduce power to the display if (i) the microprocessor determines that a telephone call is active and (ii) the signal indicates the proximity of the external object; wherein:</p>	<p>Mantyjarvi discloses the microprocessor adapted to reduce power to the display if (i) the microprocessor determines that a telephone call is active and (ii) the signal indicates the proximity of the external object.</p> <p>For example:</p> <p>“The present invention relates to a terminal for a communication system. The terminal includes detector means 7, 8 that are arranged to detect a contact between at least one surface of the terminal and the skin of the user. At least one function of the terminal is arranged to be controlled based on a signal generated by the detecting means in response to the detection. The sensor may be resistive, sensing galvanic skin resistance across</p>

linear contacts 7, 8 or could be a capacitive proximity sensor, or may be pressure sensitive.” Mantjarvi at Abstract.

“The user typically controls the operation and/or functions of the terminal by pressing appropriate buttons on a keyboard of the terminal or by lifting the handset off-hook/placing the handset on-hook or opening/closing a specific cover connected to a switch and so on. Voice activated control systems are also known. For example, when the user wishes to establish a call, he usually selects or fetches the desired destination number by pressing appropriate keys on the keyboard or he may use possible voice activation functions of the terminal. When the user receives a call, the call is typically answered by lifting the handset off-hook, or by pressing at least one key of the key board or by opening the special cover of the keyboard.

Similarly, any other functions of the terminal may be controlled by pressing appropriate keys or moving one or several components of the terminal to operate an associated switch. The functions and/or operations that need to be controlled may be functions such as switching the terminal between different modes of operation, controlling a keyboard lock or display of the terminal, switching on/off the lightning of the keyboard or the display, or controlling any other special features of the terminal or services provided for the user of the terminal (such as voice mail, short text messages, calendar or alarm functions and so on).

For example, a mobile station may be provided with a keyboard lock referred to above. The basic idea of the keypad or keyboard lock is to prevent the user to mistakenly press any of the keys when this is not desired (e.g. when the mobile station is in the pocket of the user). For example, by means of the lock it is possible to prevent an accidental call establishment to a telephone number that is not actually selected. The keyboard lock may be controlled in alternative ways. According to one possibility predefined keys of the keypad can be used for locking and unlocking the keypad of the mobile station.” Mantjarvi at 2:11-3:15.

“According to one aspect of the present invention, there is provided a terminal for a communication system, the terminal comprising detector means that are arranged to detect a contact between at least one surface of the terminal and the skin of the user of the terminal, wherein at least one function of the terminal is controlled based on a signal from the detecting means.

The detector means may comprise a first detector arrangement and a second detector arrangement, wherein said first and second detector arrangements are based on different principles of detecting a contact between the terminal and the skin of the user. The control of the terminal that is based on the signal from the detector means is preferably provided only if said first and second detector arrangements both output a signal that indicates a contact between the terminal and the skin of the user.

According to one aspect of the present invention, there is provided a detector arrangement for a terminal of a communication system, the terminal comprising at least one element that is to be held against the skin of the user of the terminal, the detector arrangement comprising circuitry for generating an output signal whenever a surface of the terminal touches in a predefined manner the skin of the user, wherein the output signal is arranged to be employed in the control of at least one function of the terminal.

According to another aspect of the present invention, there is provided a method for providing control of at least one function of a terminal of a communication system, comprising the steps of:

detecting a contact between a surface of the terminal and the skin of the user of the terminal; generating an output signal indicating a contact between the surface of the terminal and the skin of the user; and controlling said at least one function of the terminal based on the output signal.” Mäntylä at 4:4-5:10.

“Two strip electrodes 7 and 8 are attached on one side of the station 1. The electrodes 7 and 8 are employed for detecting a contact between the skin of the user and the mobile station. According to a possibility the electrodes 7 and 8 are attached on the outer surface of the housing 11 of the mobile station 1. The electrodes may also be embedded in the

cover material such that the surface of the electrodes will remain visible and may thus be touched by the skin of the user.

More particularly, the electrodes 7 and 8 may be arranged to measure so called galvanic skin response (GSR). Figure 2 discloses a block diagram for circuitry that may be used when implementing a galvanic skin response touch sensing arrangement 20. The first electrode 7 is coupled to a voltage source V_{cc} via a line 27. The voltage V_{cc} may equal the operational voltage of the mobile station, but V_{cc} may also be different from that. Voltage V_{cc} is preferably provided by the battery 10 of the mobile station 1. A buffer 21 and an appropriate impedance 24 8 may be provided for scaling the current and voltage on the line 27 between the electrode 7 and the voltage source V_{cc} . The second electrode 8 is coupled to an output 26 of the circuitry 20. The signal from the electrode 8 may be amplified by an amplifier 23 before the signal is output from the circuitry 20. The amplifier circuit may comprise a resistor/ impedance 25.

The galvanic skin response (GSR) detection method is based on provision of a conductive path between two or more electrodes. When the user grips the mobile station 1 by his hand (not shown), the skin of the hand will provide the conductive path between the electrodes 7 and 8 of Figures 1 and 2. Now, when a conductive path is provided between the electrodes 7 and 8, the voltage and current at the output line 26 will change in accordance with known principles. The GSR sensing arrangement 20 gives typically so-called TTL level (transistor to transistor logic level) output signal when the conductive material is in touch with at last two of the electrodes. A component 22 may be used for setting an appropriate threshold level for the conductivity, i.e. the component 22 may trigger the circuitry 20 to output a signal that indicates a contact between the hand of the user and the mobile station 1.” Mäntyjärvi at 7:14-8:22.

“As illustrated by the flow chart of figure 6, the output signal on line 26 may be used in the control of a function of the mobile station. As illustrated by the flow chart of figure 6, the output signal on line 26 may be used in the control of a function of the mobile station. For example, activation of a mobile station that is in a standby mode may be based on the output signal from the sensing arrangement. The activation of the mobile station may be triggered by the control unit 12 of the mobile station based on a received

TTL level signal output 26 from the GSR arrangement 20. The station may be correspondingly deactivated i.e. returned 9 to the standby mode after the control unit no longer receives the TTL level signal. An automated keyboard lock may function in a corresponding manner, i.e. the keyboard may be unlocked only when the GSR detecting arrangement outputs a TTL level signal. The station may also be switched between different modes of operation or even on and off based on the output signal received from the detecting means. The lighting of the keypad and/or the display may be controlled based on this information.” Mäntylä at 8:24-9:8.

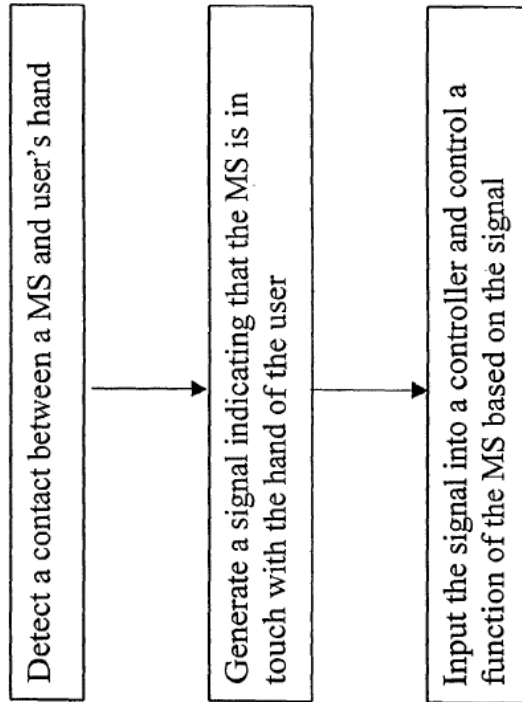

FIG. 6

Mäntylä at Fig. 6.

“The controller may provide different instructions for the controlled functions depending the location or the context where the control is provided. For example, during

a normal speech call the lighting of the display and/or keyboard may be switched off after a predefined time has lapsed from the activation thereof. However, the lightning will stay on if the connection was established for data communication, such as for a wireless application protocol (WAP) connection or for an Internet connection.” Mantyjärvi at 14:21-30.

“Another possibility for measuring the presence of the living tissue in touch or in close proximity with the terminal is so called capacitive proximity (CP) sensor. The capacitive proximity sensor requires only one electrode, even though it is possible to use several CP sensors. The CP based system can be adjusted to sense the proximity of the living tissue, for example such that a CP sensing arrangement will react when the distance between the skin of the user and the mobile station is within a range of 0 to 5 mm. The capacitive proximity sensors may be arranged to be sensitive only for living tissue, and will thus not react to other materials. When the capacitive proximity sensor senses a living tissue, it may output an appropriate signal, such as a TTL level signal. The use of the TTL level output signal in accordance with the invention was already discussed above.

Figure 4 shows a schematic block diagram for a detection circuitry 31 based on the capacitive proximity sensor detection. In general, the circuitry 31 can be defined as oscillating circuitry that is implemented by means of a flip-flop switch 32. The circuitry 31 is provided with suitable triggering means 33, such as a Schmitt trigger. An inverting amplifier 34 may also be provided on the output line 35. The circuitry operates such that when the capacitive sensor 30 is touched by a living tissue, the output on line 35 will rise in the Vcc level, thus providing a signal indicating that the terminal is in touch with living tissue.

The capacitive proximity sensor may also detect a living tissue, such as the skin of the user, that is not in an direct contact with the sensors. The skin may be, for example, within a distance that is up to 5 mm from the sensing electrode. Therefore the capacitive proximity electrode 30 may be placed on the internal surface of the cover material of the terminal 1 or may be embedded within the cover material of the terminal 1. For example,

it could be placed inside the cover of the battery 10 of the mobile terminal 1.” Mantjarvi at 10:20-11:25.

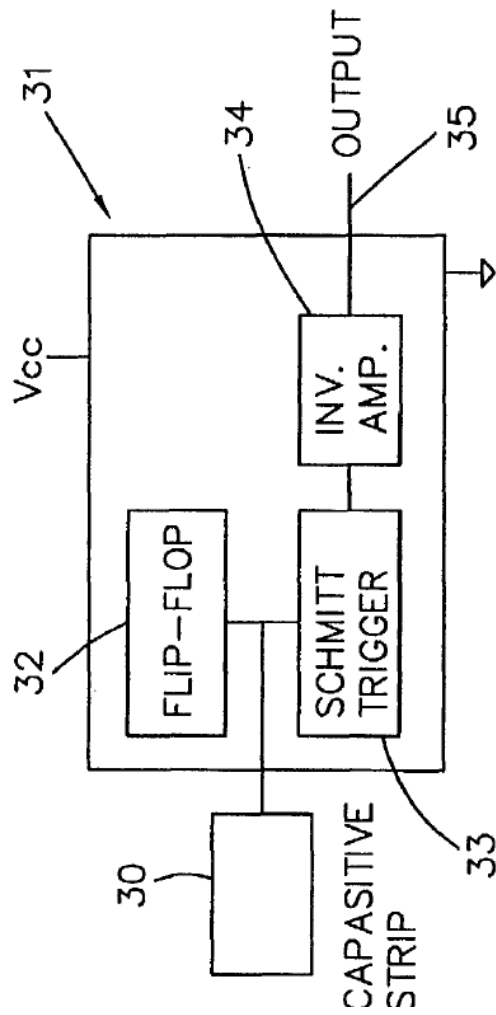

FIG. 4

Mantjarvi at Fig. 4.

“Figure 5 shows an embodiment in which the output signals of the above discussed two different sensing techniques are combined prior a signal is inputted into the controller of the terminal.

In brief, the arrangement of Figure 5 is such that an output signal 41 is provided by a combiner 40 only when both the galvanic skin response circuitry 20 and the capacitive proximity circuitry 31 provide a positive TTL level output signal to the combiner 40. By

employing both the galvanic skin response and the capacitive proximity method in the same terminal it is possible to decrease the risk for incorrect signals and thus improve the reliability of the detection arrangement.” Mäntyjärvi at 13:8-18.

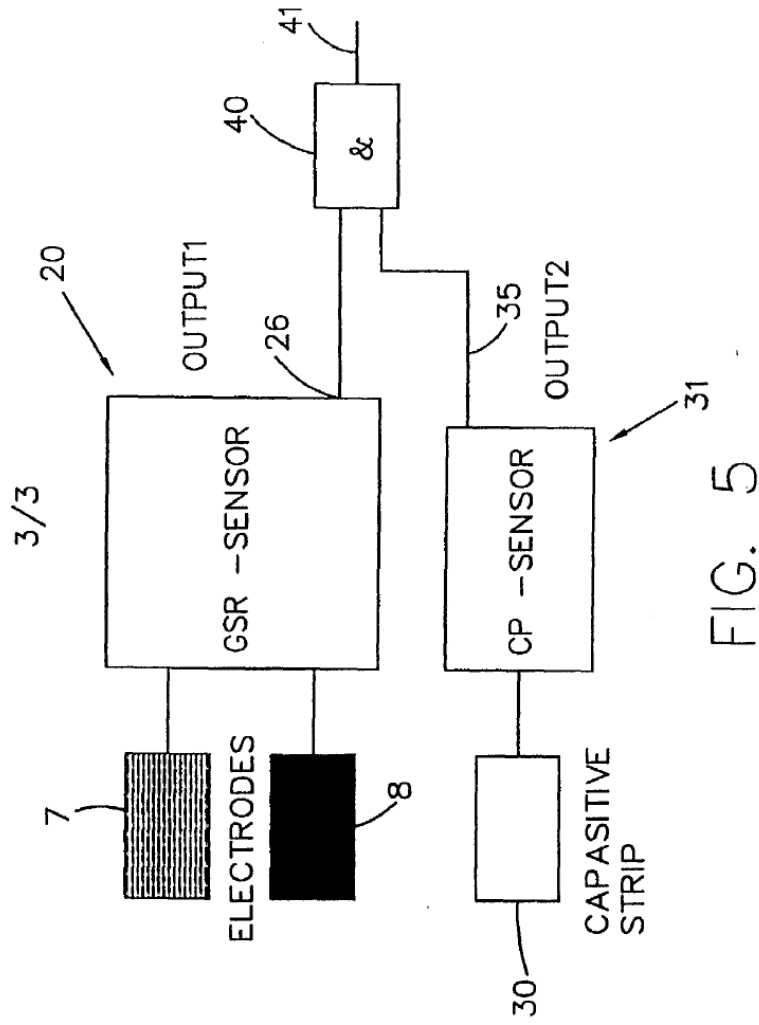

Mäntyjärvi at Fig. 5.

“The controller may provide different instructions for the controlled functions depending the location or the context where the control is provided. For example, during a normal speech call the lighting of the display and/or keyboard may be switched off

after a predefined time has lapsed from the activation thereof. However, the lightning will stay on if the connection was established for data communication, such as for a wireless application protocol (WAP) connection or for an Internet connection.”
Mantyjärvi at 14:21-30.

“Therefore a verification of the detection result of a detection arrangement may be desirable in some applications. The verification can be provided by employing more than one sensing technique in the generation of the output signal to make sure that the terminal is indeed in the hand of the user or against the cheek or ear of the user.”
Mantyjärvi at 13:2-6.

“1. A terminal for a communication system, the terminal comprising detector means that are arranged to detect a contact between at least one surface of the terminal and the skin of the user of the terminal, wherein at least one function of the terminal is controlled based on a signal from the detecting means.” Mantyjärvi at Claim 1.

“2. A terminal according to claim 1, wherein the detector means comprise a first detector arrangement and a second detector arrangement, wherein said first and second detector arrangements are based on different principles of detecting a contact between the terminal and the skin of the user.” Mantyjärvi at Claim 2

“3. A terminal according to claim 2, wherein the control based on the signal from the detector means is provided only if said first and second detector arrangements both output a signal that indicates a contact between the terminal and the skin of the user.”
Mantyjärvi at Claim 3.

“ 24. A terminal according to any of the preceding claims, wherein the control of the function is based, in addition to the signal from the detector means, on at least one of the following: the operational status of the terminal; the location of the terminal; the time of the day; the time of the year; temperature; the type of the communication.” Mantyjärvi at Claim 24.

“27. A detector arrangement for a terminal of a communication system, the terminal comprising at least one element that is to be held against the skin of the user of the terminal, the detector arrangement comprising circuitry for generating an output signal whenever a surface of the terminal touches in a predefined manner the skin of the user, wherein the output signal is arranged to be employed in the control of at least one function of the terminal.” Mantyjärvi at Claim 27.

“31. A method according to claim 30, wherein the generation of the output signal comprises further steps of:

receiving a first signal from a first detector arrangement; 21 receiving a second signal from a second detector arrangement that is different from the operation principles thereof from the first detector arrangement; verifying the first and second signals; and generating the output signal if said first and second signals indicate similar results of detection.” Mantyjärvi at Claim 33

To the extent Mantyjärvi is deemed to not expressly disclose the microprocessor adapted to “(c) reduce power to the display if (i) the microprocessor determines that a telephone call is active and (ii) the signal indicates the proximity of the external object,” Mantyjärvi inherently discloses this limitation or renders it obvious to a person of ordinary skill in

<p>[1g] the telephone call is a wireless telephone call;</p>	<p>the art at the time of the alleged invention for the reasons described in claim element [1h], <i>in/ra</i>, incorporate herein by reference.</p>
<p>[1g] the telephone call is a wireless telephone call;</p>	<p>MantylarvI discloses the telephone call as a wireless telephone call.</p> <p>For example:</p> <p>“In a communication system a terminal is used for providing a user interface for the user of the communication system. In other words, by means of the terminal the user may access and communicate over the communication system.</p> <p>An example of the terminal is a mobile station that may be used in a radio communication system. The mobile station is typically a portable hand-held device that provides, in cooperation with the radio communication system, mobility for the user. When the mobile station is not in use, it is usually positioned in the user's pocket or in a special case or similar. The mobile station typically comprises a keypad for controlling the operation thereof, such as for dialing in a desired telephone number and for controlling various functions of the mobile station. A mobile station is also typically provided with a display. The display may be used for showing various information to the user of the mobile station. Instead of being an entirely hand-held unit, a mobile station may also comprise separate units, such as a base transceiver unit and a separate handset portion and/or a separate headset portion.” MantylarvI at 1:10-29.</p> <p>“Figure 1 shows a mobile station in accordance with an embodiment of the present invention. The mobile station 1 comprises a housing or cover portion 11 which protects and encapsulates the various internal components of the mobile station. The internal components are not shown in greater detail, but may typically comprise components such as a processor 12 that is for controlling one or several functions of the mobile station.” MantylarvI at 6:10-16.</p>

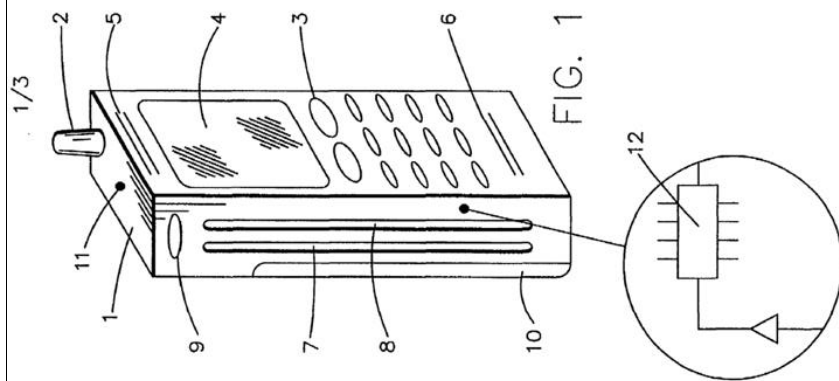

Mantjarvi at Fig. 1.

26. A terminal according to any of the preceding claims, wherein the terminal comprises a mobile station of a radio communication system.” Mantjarvi at Claim 26.

	<p>For example: <i>see</i> discussion of claim element 1[d], <i>supra</i>, which is incorporated herein by reference.</p>
<p>[1h] the microprocessor reduces power to the display while the signal indicates the proximity of the external object only if the microprocessor determines that the wireless telephone call is active; and</p>	<p>Mantjarvi discloses that the microprocessor reduces power to the display while the signal indicates the proximity of the external object only if the microprocessor determines that the wireless telephone call is active:</p> <p>For example:</p> <p><i>See</i> discussion of claim element [1f], <i>supra</i>, which is incorporated herein by reference.</p> <p>To the extent Mantjarvi is deemed to not disclose “the microprocessor reduces power to the display while the signal indicates the proximity of the external object only if the microprocessor determines that the wireless telephone call is active,” Mantjarvi renders this limitation obvious to one of ordinary skill in the art at the time of the alleged invention. For example, Mantjarvi discloses that “[i]n addition, the sensitivity of the control unit of the mobile station can be adjusted in accordance with specific requirements and/or conditions and may vary if the requirements and/or conditions change. According to an embodiment other information may also be employed when providing the control of a function of the terminal. For example, it may be desired to be able to adjust the sensitivity in accordance with the changed temperature conditions, as a cold hand is less conductive than a warm (and thus sweaty) hand. The controller may provide different instructions for the controlled functions depending the location or the context where the control is provided.” Mantjarvi at 14-15. A person of ordinary skill in the art at the time of the alleged invention would understand Mantjarvi’s disclosure of modifying the “sensitivity of the control unit” based on “specific requirements and/or conditions,” including that “[t]he controller may provide different instructions for the controlled functions depending the location or the context where the control is provided “as rendering obvious microprocessor reduces power to the display while the signal indicates the proximity of the external object only if the microprocessor determines that the wireless telephone call is active.” For example, one of ordinary skill in the art at the time of the alleged invention would understand that they could “modify the sensitivity” of the microprocessor for controlling functions such as turning off the display of the</p>

mobile station, by requiring the microprocessor to determine “that the wireless telephone call is active” in addition to receiving a “signal indicat[ing] the proximity of the external object” before it performs the function of shutting off the display. Such a modification would be obvious to one of ordinary skill in the art at the time of the alleged invention when “conditions” warrant that the microprocessor detect both the wireless telephone call and the signal from the proximity sensor, such as, for example, when there is reason to doubt the accuracy of the signal of the proximity sensor in insolation. In fact Mantlyjarvi discloses the possibility of such circumstances. *See* Mantlyjarvi at 12:27-13:2 (“Therefore there may be, in some circumstances, a possibility to get an incorrect output signal from the detector means 20 of Figure 2. The close proximity (CP) 30 method may also give false signals, for example when there is a very thin textile between the electrode and the human skin. Therefore a verification of the detection result of a detection arrangement may be desirable in some applications.”). It would therefore be obvious to one of ordinary skill in the art to modify Mantlyjarvi such that “the microprocessor reduces power to the display while the signal indicates the proximity of the external object only if the microprocessor determines that the wireless telephone call is active,” or to combine Mantlyjarvi with other art that discloses this limitation (see discussion of combination with Fukiharu 598, below). Doing so would be within the knowledge and ability of a person of ordinary skill in the art at the time of the alleged invention. Doing so would also constitute, at least, combining prior art elements according to known methods to yield predictable results, a simple substitution of one known element for another to obtain predictable results, the use of a known technique to improve similar devices in the same way, the application of a known technique to a known device ready for improvement to yield a predictable result, and obvious to try.

To the extent Mantlyjarvi is deemed to not expressly or inherently disclose the microprocessor adapted to the microprocessor reduces power to the display while the signal indicates the proximity of the external object only if the microprocessor determines that the wireless telephone call is active,” it would be obvious to combine the disclosure of Mantlyjarvi with those of Fukiharu 598 as described in the Fukiharu 598 claim chart, which is incorporated herein in its entirety by reference. Mantlyjarvi and Fukiharu 598 are both directed to controlling the functionality of mobile stations based

in part on signals from a proximity sensor. *See, e.g.,* Mantyjärvi at 3:30-4:2 (“It is an aim of the embodiments of the present invention to address one or several of the disadvantages of the prior art terminals and to provide a new type of solution for controlling one or several functions of a terminal.”); Fukiharu 598 at Abstract (“The object of the present invention is to provide a mobile telephone with a lighting device, and a method for controlling said lighting device, with improved portability through reducing the weight and volume of the battery, and to enable a thorough increase in talk time and standby time, through controlling, through a touch sensor that is provided on a receiver portion surface of the mobile telephone, operation of a lighting device (backlight) of a liquid crystal display device and/or a key pad portion.”). More particularly both Mantyjärvi and Fukiharu 598 disclose turning off the display of a mobile station based on signals from a proximity sensor indicating that a user’s face or ear is in close proximity to the mobile station. *See, e.g.,* Mantyjärvi at Claim 1 (“A terminal for a communication system, the terminal comprising detector means that are arranged to detect a contact between at least one surface of the terminal and the skin of the user of the terminal, wherein at least one function of the terminal is controlled based on a signal from the detecting means.”), Mantyjärvi at Claim 8 (“A terminal according to any of the preceding claims, wherein the operation of a display of the terminal is controlled based on the signal from the detector means.”), Mantyjärvi at Claim 11 (“A terminal according to any of the preceding claims, wherein the detector means are arranged to sense a contact between the terminal and the cheek and/or ear of the user.”); Fukiharu 598 at ¶0015 (“At this time, the lighting-ON state is maintained if not in the voice communication mode. If in the voice communication mode, a touch sensor 2c is placed into an operating state by a signal from the controlling portion 2a, and constantly outputs a detection output to the controlling portion 2a. If the touch sensor 2c contacts a portion of the human body, such as an ear, a lighting-OFF signal is outputted to the lighting device ON/OFF circuit portion 2b from the controlling portion 2a through the ON output of the touch sensor 2c, and the power supplies to both the lighting device (backlight) 3a and the lighting device (backlight) 4a go to the OFF state, and this lighting-OFF state is maintained until the touch sensor 2c goes into a non-contact state.”). A person of ordinary skill in the art at the time of the alleged invention would therefore understand that both Mantyjärvi and Fukiharu 598 disclose ways of conserving battery power by shutting of the display of a mobile station at such times that the user of the mobile station is unlikely to be looking at the display (as indicated by at least a proximity

	<p>sensor). A person of ordinary skill in the art at the time of the alleged invention would be therefore be motivated to modify Mantiyarvi such that “the microprocessor reduces power to the display while the signal indicates the proximity of the external object only if the microprocessor determines that the wireless telephone call is active,” as disclosed in Fukiharu 598 for a number of different reasons, including that it would support Mantiyarvi’s ability to conserve battery power in mobile stations. Doing so would further support Mantiyarvi’s ability to provide means for “controlling of at least one function of a terminal of a communication system” (Mantiyarvi at 1:5-6) where the “sensitivity of the control unit of the mobile station can be adjusted in accordance with specific requirements and/or conditions and may vary if the requirements and/or conditions change.” Mantiyarvi at 14:13-16. Doing so would be within the knowledge and ability of a person of ordinary skill in the art at the time of the alleged invention. The combination would constitute, at least, combining prior art elements according to known methods to yield predictable results, a simple substitution of one known element for another to obtain predictable results, the use of a known technique to improve similar devices in the same way, the application of a known technique to a known device ready for improvement to yield a predictable result, and obvious to try.</p>
<p>[11] the proximity sensor begins detecting whether an external object is proximate substantially concurrently with the mobile station initiating an outgoing wireless telephone call or receiving an incoming wireless telephone call.</p>	<p>Mantiyarvi discloses the proximity sensor beginning to detect whether an external object is proximate substantially concurrently with the mobile station initiating an outgoing wireless telephone call or receiving an incoming wireless telephone call:</p> <p>For example:</p> <p><i>See</i> discussion of claim element [1f], <i>supra</i>, which is incorporated herein by reference.</p> <p>“According to one aspect of the present invention, there is provided a terminal for a communication system, the terminal comprising detector means that are arranged to detect a contact between at least one surface of the terminal and the skin of the user of</p>

the terminal, wherein at least one function of the terminal is controlled based on a signal from the detecting means.

The detector means may comprise a first detector arrangement and a second detector arrangement, wherein said first and second detector arrangements are based on different principles of detecting a contact between the terminal and the skin of the user. The control of the terminal that is based on the signal from the detector means is preferably provided only if said first and second detector arrangements both output a signal that indicates a contact between the terminal and the skin of the user.

According to one aspect of the present invention, there is provided a detector arrangement for a terminal of a communication system, the terminal comprising at least one element that is to be held against the skin of the user of the terminal, the detector arrangement comprising circuitry for generating an output signal whenever a surface of the terminal touches in a predefined manner the skin of the user, wherein the output signal is arranged to be employed in the control of at least one function of the terminal.

According to another aspect of the present invention, there is provided a method for providing control of at least one function of a terminal of a communication system, comprising the steps of:

detecting a contact between a surface of the terminal and the skin of the user of the terminal; generating an output signal indicating a contact between the surface of the terminal and the skin of the user; and controlling said at least one function of the terminal based on the output signal.” Mäntyjärvi at 4:4-5:10.

“As illustrated by the flow chart of figure 6, the output signal on line 26 may be used in the control of a function of the mobile station. As illustrated by the flow chart of figure 6, the output signal on line 26 may be used in the control of a function of the mobile station. For example, activation of a mobile station that is in a standby mode may be based on the output signal from the sensing arrangement. The activation of the mobile station may be triggered by the control unit 12 of the mobile station based on a received TTL level signal output 26 from the GSR arrangement 20. The station may be

correspondingly deactivated i.e. returned 9 to the standby mode after the control unit no longer receives the TTL level signal. An automated keyboard lock may function in a corresponding manner, i.e. the keyboard may be unlocked only when the GSR detecting arrangement outputs a TTL level signal. The station may also be switched between different modes of operation or even on and off based on the output signal received from the detecting means. The lighting of the keypad and/or the display may be controlled based on this information.’ Mantyjärvi at 8:24-9:8.

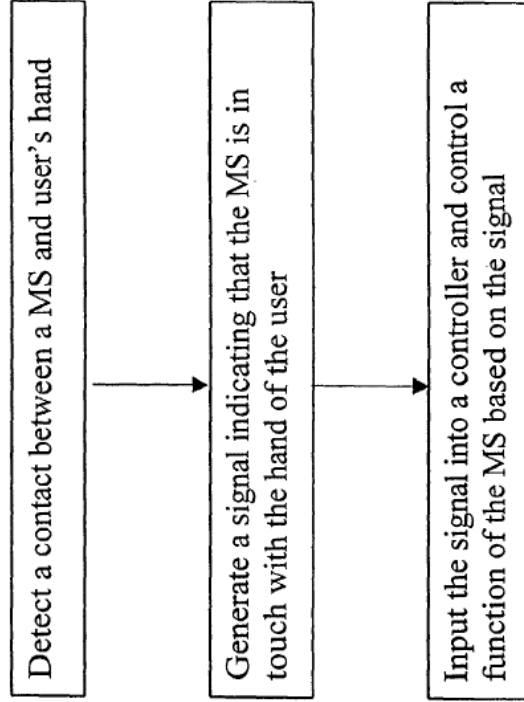
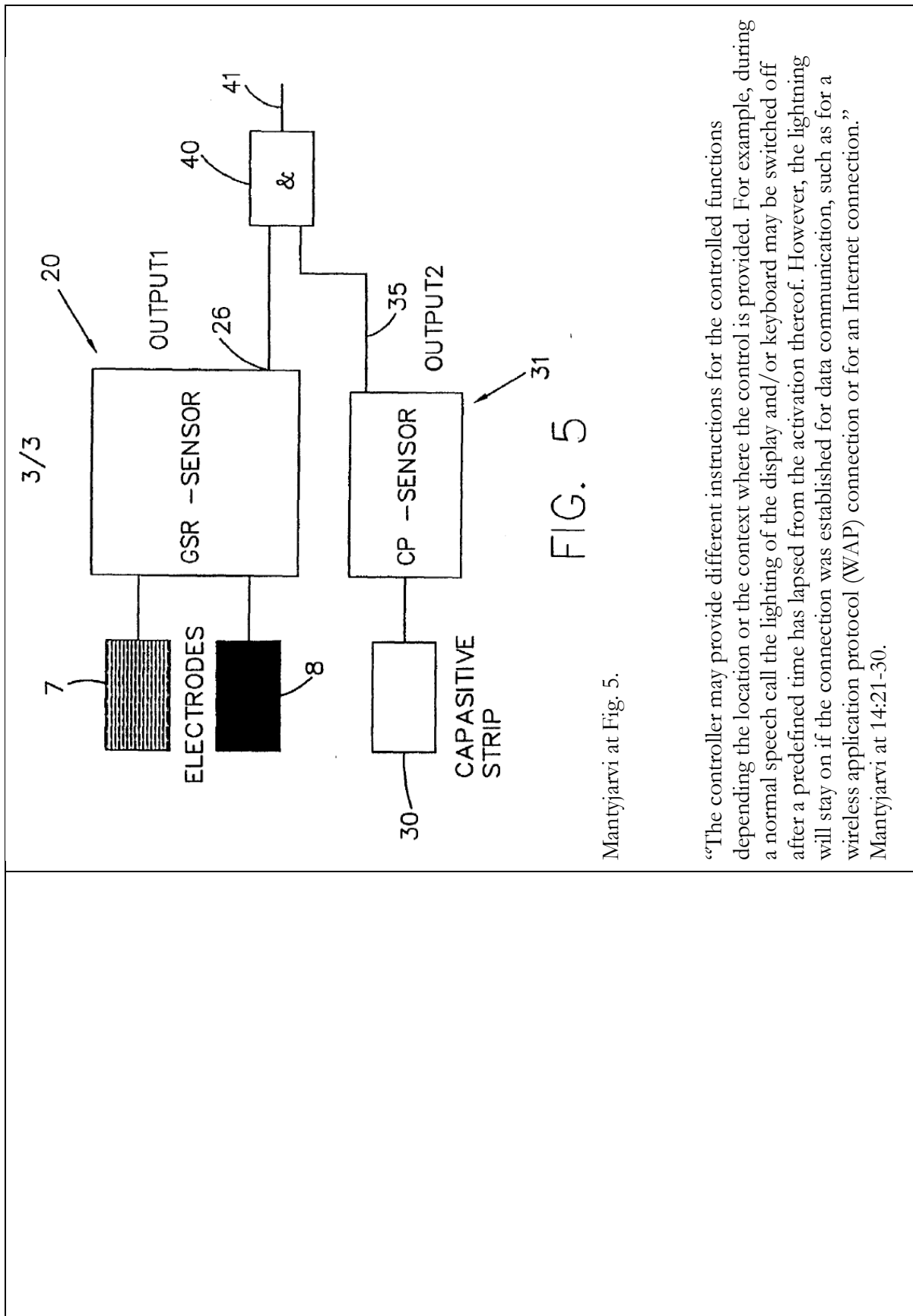

FIG. 6

Mantyjärvi at Fig. 6.

“Figure 5 shows an embodiment in which the output signals of the above discussed two different sensing techniques are combined prior a signal is inputted into the controller of the terminal.

In brief, the arrangement of Figure 5 is such that an output signal 41 is provided by a combiner 40 only when both the galvanic skin response circuitry 20 and the capacitive proximity circuitry 31 provide a positive TTL level output signal to the combiner 40. By employing both the galvanic skin response and the capacitive proximity method in the same terminal it is possible to decrease the risk for incorrect signals and thus improve the reliability of the detection arrangement.” Mäntyjärvi at 13:8-18.



3/3

FIG. 5

Mantjarvi at Fig. 5.

“The controller may provide different instructions for the controlled functions depending the location or the context where the control is provided. For example, during a normal speech call the lighting of the display and/or keyboard may be switched off after a predefined time has lapsed from the activation thereof. However, the lightning will stay on if the connection was established for data communication, such as for a wireless application protocol (WAP) connection or for an Internet connection.”
 Mantjarvi at 14:21-30.

“The sensing arrangement may also be adapted such that it will take changes in the time of the day and/or seasons of the year or changes in the conductivity of the components used for the sensors into account. The adjustment may also be adaptive so that the controller may itself adjust the operation thereof to be within certain predefined parameters.” Mantiyarvi at 14:30-15:4.

“Therefore a verification of the detection result of a detection arrangement may be desirable in some applications. The verification can be provided by employing more than one sensing technique in the generation of the output signal to make sure that the terminal is indeed in the hand of the user or against the cheek or ear of the user.” Mantiyarvi at 13:2-6.

“1. A terminal for a communication system, the terminal comprising detector means that are arranged to detect a contact between at least one surface of the terminal and the skin of the user of the terminal, wherein at least one function of the terminal is controlled based on a signal from the detecting means.” Mantiyarvi at Claim 1.

“2. A terminal according to claim 1, wherein the detector means comprise a first detector arrangement and a second detector arrangement, wherein said first and second detector arrangements are based on different principles of detecting a contact between the terminal and the skin of the user.” Mantiyarvi at Claim 2.

“3. A terminal according to claim 2, wherein the control based on the signal from the detector means is provided only if said first and second detector arrangements both

output a signal that indicates a contact between the terminal and the skin of the user.”
Mantjarvi at Claim 3.

“ 24. A terminal according to any of the preceding claims, wherein the control of the function is based, in addition to the signal from the detector means, on at least one of the following: the operational status of the terminal; the location of the terminal; the time of the day; the time of the year; temperature; the type of the communication.” Mantjarvi at Claim 24.

“27. A detector arrangement for a terminal of a communication system, the terminal comprising at least one element that is to be held against the skin of the user of the terminal, the detector arrangement comprising circuitry for generating an output signal whenever a surface of the terminal touches in a predefined manner the skin of the user, wherein the output signal is arranged to be employed in the control of at least one function of the terminal.” Mantjarvi at Claim 27.

“31. A method according to claim 30, wherein the generation of the output signal comprises further steps of:

receiving a first signal from a first detector arrangement; 21 receiving a second signal from a second detector arrangement that is different from the operation principles thereof from the first detector arrangement; verifying the first and second signals; and generating the output signal if said first and second signals indicate similar results of detection.” Mantjarvi at Claim 33.

To the extent Mantjarvi is deemed to not disclose that “the proximity sensor begins detecting whether an external object is proximate substantially concurrently with the

mobile station initiating an outgoing wireless telephone call or receiving an incoming wireless telephone call.” Mantiyarvi renders this limitation obvious to one of skill in the art. Mantiyarvi discloses that a mobile station “may also be switched between different modes of operation or even on and off based on the output signal received from the detecting means. The lighting of the keypad and/or the display may be controlled based on this information.” Mantiyarvi at 9:5-8. Mantiyarvi also discloses “receiving a first signal from a first detector arrangement; 21 receiving a second signal from a second detector arrangement that is different from the operation principles thereof from the first detector arrangement; verifying the first and second signals; and generating the output signal if said first and second signals indicate similar results of detection.” Mantiyarvi at Claim 33. A person of ordinary skill in the art at the time of the alleged invention would be motivated to modify Mantiyarvi to disclose this claim element because in order to determine whether “the first and second signals indicate similar results of detection,” the two signals should be temporally similar. Further, a person of ordinary skill in the art at the time of the alleged invention would be motivated to modify Mantiyarvi in this way because doing so would improve Mantiyarvi’s desired function of enabling a mobile station “to be controlled based on a signal generated by the detecting means in response to the detection.” Mantiyarvi at Abstract. It would not be difficult for a skilled artisan to modify Mantiyarvi’s mobile station such that its “proximity sensor begins detecting whether an external object is proximate substantially concurrently with the mobile station initiating an outgoing wireless telephone call or receiving an incoming wireless telephone call.” because the mobile station in Mantiyarvi is already configured to determine that a telephone call is active, and to reduce power to the display if the signal indicates the proximity of the external object. *See* discussion of claim elements 1[b], 1[d], 1[f], *supra*. This modification would thereby produce predictable results. Doing so would be within the knowledge and ability of a person of ordinary skill in the art at the time of the alleged invention. Doing so would also constitute, at least, combining prior art elements according to known methods to yield predictable results, a simple substitution of one known element for another to obtain predictable results, the use of a known technique to improve similar devices in the same way, the application of a known technique to a known device ready for improvement to yield a predictable result, and obvious to try.

To the extent Mäntyjärvi is deemed to not expressly or inherently disclose that “the proximity sensor begins detecting whether an external object is proximate substantially concurrently with the mobile station initiating an outgoing wireless telephone call or receiving an incoming wireless telephone call,” it would be obvious to combine the disclosure of Mäntyjärvi with those of Fukiharu 598 as described in the Fukiharu 598 claim chart, which is incorporated herein in its entirety by reference. Mäntyjärvi and Fukiharu 598 are both directed to controlling the functionality of mobile stations based in part on signals from a proximity sensor. *See, e.g.*, Mäntyjärvi at 3:30-4:2 (“It is an aim of the embodiments of the present invention to address one or several of the disadvantages of the prior art terminals and to provide a new type of solution for controlling one or several functions of a terminal.”); Fukiharu 598 at Abstract (“The object of the present invention is to provide a mobile telephone with a lighting device, and a method for controlling said lighting device, with improved portability through reducing the weight and volume of the battery, and to enable a thorough increase in talk time and standby time, through controlling, through a touch sensor that is provided on a receiver portion surface of the mobile telephone, operation of a lighting device (backlight) of a liquid crystal display device and/or a key pad portion.”). More particularly both Mäntyjärvi and Fukiharu 598 disclose turning off the display of a mobile station based on signals from a proximity sensor indicating that a user’s face or ear is in close proximity to the mobile station. *See, e.g.*, Mäntyjärvi at Claim 1 (“A terminal for a communication system, the terminal comprising detector means that are arranged to detect a contact between at least one surface of the terminal and the skin of the user of the terminal, wherein at least one function of the terminal is controlled based on a signal from the detecting means.”), Mäntyjärvi at Claim at 8 (“A terminal according to any of the preceding claims, wherein the operation of a display of the terminal is controlled based on the signal from the detector means.”), Mäntyjärvi at Claim 11 (“A terminal according to any of the preceding claims, wherein the detector means are arranged to sense a contact between the terminal and the cheek and/or ear of the user.”); Fukiharu 598 at ¶0015 (“At this time, the lighting-ON state is maintained if not in the voice communication mode. If in the voice communication mode, a touch sensor 2c is placed into an operating state by a signal from the controlling portion 2a, and constantly outputs a detection output to the controlling portion 2a. If the touch sensor 2c contacts a portion of the human body, such as an ear, a lighting-OFF signal is outputted to the lighting device ON/OFF circuit portion 2b from the controlling portion 2a through the ON

	<p>output of the touch sensor 2c, and the power supplies to both the lighting device (backlight) 3a and the lighting device (backlight) 4a go to the OFF state, and this lighting-OFF state is maintained until the touch sensor 2c goes into a non-contact state.”). A person of ordinary skill in the art at the time of the alleged invention would therefore understand that both Mantyjärvi and Fukiharu 598 disclose ways of conserving battery power by shutting of the display of a mobile station at such times that the user of the mobile station is unlikely to be looking at the display (as indicted by at least a proximity sensor). A person of ordinary skill in the art at the time of the alleged invention would be therefore be motivated to modify Mantyjärvi such that “the proximity sensor begins detecting whether an external object is proximate substantially concurrently with the mobile station initiating an outgoing wireless telephone call or receiving an incoming wireless telephone call,” as disclosed in Fukiharu 598 for a number of different reasons, including that it would support Mantyjärvi’s ability to conserve battery power in mobile stations. Doing so would further support Mantyjärvi’s ability to provide means for “controlling of at least one function of a terminal of a communication system” (Mantyjärvi at 1:5-6) where the “sensitivity of the control unit of the mobile station can be adjusted in accordance with specific requirements and/or conditions and may vary if the requirements and/or conditions change.” Mantyjärvi at 14:13-16. Doing so would be within the knowledge and ability of a person of ordinary skill in the art at the time of the alleged invention. The combination would constitute, at least, combining prior art elements according to known methods to yield predictable results, a simple substitution of one known element for another to obtain predictable results, the use of a known technique to improve similar devices in the same way, the application of a known technique to a known device ready for improvement to yield a predictable result, and obvious to try.</p>
<p>[Claim 2] The mobile station of claim 1, wherein the microprocessor reduces power to the display only if (i) the microprocessor determines that a telephone call is active and</p>	<p>Mantyjärvi discloses the microprocessor reducing power to the display only if (i) the microprocessor determines that a telephone call is active and (ii) the signal indicates the proximity of the external object.</p>

<p>(ii) the signal indicates the proximity of the external object.</p>	<p>For example: <i>See</i> discussion of claim element [1f], <i>supra</i>, which is incorporated herein by reference.</p>
<p>[Claim 4] The mobile station as recited in claim 1, wherein the microprocessor reduces power to the display by turning off the display.</p>	<p>Mantyjärvi discloses the microprocessor reducing power to the display by turning off the display.</p> <p>For example:</p> <p>“The controller may provide different instructions for the controlled functions depending the location or the context where the control is provided. For example, during a normal speech call the lighting of the display and/or keyboard may be switched off after a predefined time has lapsed from the activation thereof. However, the lightning will stay on if the connection was established for data communication, such as for a wireless application protocol (WAP) connection or for an Internet connection.” Mantyjärvi at 14:21-30.</p> <p>“The station may also be switched between different modes of operation or even on and off based on the output signal received from the detecting means. The lighting of the keypad and/or the display may be controlled based on this information.” Mantyjärvi at 9:5-8.</p> <p>“Similarly, any other functions of the terminal may be controlled by pressing appropriate keys or moving one or several components of the terminal to operate an associated switch. The functions and/or operations that need to be controlled may be functions such as switching the terminal between different modes of operation, controlling a keyboard lock or display of the terminal, switching on/off the lightning of the keyboard or the display, or controlling any other special features of the terminal or services provided for the user of the terminal (such as voice mail, short text messages, calendar or alarm functions and so on).” Mantyjärvi at 2:23-3:2.</p>

	<p>“The embodiments of the invention may provide an automated and reliable control of at least one function, such as the keyboard lock and/or switching between different modes of operation of the terminal (e.g. standby and activated) and/or special service or feature. The embodiments may make the use of the terminal more convenient. The embodiments may prevent any unwanted activation of one or several of the functions of the terminal while the terminal is not in use.” Mantjarvi at 5:12-19.</p> <p>See discussion of claim element [1f], <i>supra</i>, which is incorporated herein by reference.</p> <p>To the extent Mantjarvi is deemed to not expressly disclose that “the microprocessor reduces power to the display by turning off the display,” Mantjarvi inherently discloses this limitation. Specifically, Mantjarvi states that “[t]he station may also be switched between different modes of operation or even on and off based on the output signal received from the detecting means. The lighting of the keypad and/or the display may be controlled based on this information.” Mantjarvi at 9:5-8. A person of skilled in the art would understand that if the mobile station in Mantjarvi may be “switched...on and off based on the output signal received from the detecting means,” the mobile station necessarily reduces power to the display by turning off the display.</p> <p>To the extent Mantjarvi is deemed to not expressly or inherently disclose “the microprocessor reduces power to the display by turning off the display,” Mantjarvi renders it obvious to one of skill in the art. A person of ordinary skill in the art at the time of the alleged invention would be motivated to modify Mantjarvi’s mobile station to reduce power to the display by turning off the display because doing so would improve Mantjarvi’s desired function of enabling a mobile station “to be controlled based on a signal generated by the detecting means in response to the detection.” Mantjarvi at Abstract.</p>
<p>[Claim 5] The mobile station as recited in claim 1, wherein the proximity sensor is a</p>	<p>Mantjarvi discloses that the proximity sensor is a mechanical proximity sensor, an optical sensor, or a range-detecting sensor.</p>

mechanical proximity sensor, an optical sensor, or a range-detecting sensor.

For example:

See discussion of claim element [1b], *supra*, which is incorporated herein by reference.

To the extent Mantjarvi is deemed to not expressly disclose “the proximity sensor is a mechanical proximity sensor, an optical sensor, or a range-detecting sensor,” Mantjarvi inherently discloses this limitation. In Mantjarvi, detector means 7, 8, can detect the “contact” from them human body. *See* Mantjarvi at Abstract (“The terminal includes detector means 7, 8 that are arranged to detect a contact between at least one surface of the terminal and the skin of the user. At least one function of the terminal is arranged to be controlled based on a signal generated by the detecting means in response to the detection. The sensor may be resistive, sensing galvanic skin resistance across linear contacts 7, 8 or could be a capacitive proximity sensor, or may be pressure sensitive.”) A person of ordinary skill in the art at the time of the alleged invention would understand that detecting this contact is accomplished by mechanical proximity sensor. Thus, a person of ordinary skill in the art at the time of the alleged invention would understand Mantjarvi to inherently disclose “the proximity sensor is a mechanical proximity sensor, an optical sensor, or a range-detecting sensor.”

To the extent Mantjarvi is deemed to not expressly or inherently disclose “the proximity sensor is a mechanical proximity sensor, an optical sensor, or a range-detecting sensor,” Mantjarvi renders it obvious to one of ordinary skill in the art at the time of the alleged invention to use a mechanical proximity sensor. A person of ordinary skill in the art at the time of the alleged invention would be aware of “conventional mechanical proximity (load) sensors,” which the ’889 Patent identifies as known prior art. *See* ’889 Patent at 3:15-20. A person of ordinary skill in the art at the time of the alleged invention would understand that a mechanical proximity sensor could be used to detect contact with a portion of the human body, such as an ear. Using a mechanical proximity sensor would constitute, at least, combining prior art elements according to known methods to yield predictable results, a simple substitution of one known element for another to obtain predictable results, the use of a known technique to improve similar devices in the same

way, the application of a known technique to a known device ready for improvement to yield a predictable result, and obvious to try.

To the extent Mantyjärvi is deemed to not expressly or inherently disclose that “the proximity sensor is a mechanical proximity sensor, an optical sensor, or a range-detecting sensor,” it would be obvious to combine the disclosure of Mantyjärvi with those of Fukiharu 598 as described in the Fukiharu 598 claim chart, which is incorporated herein in its entirety by reference. Mantyjärvi and Fukiharu 598 are both directed to controlling the functionality of mobile stations based in part on signals from a proximity sensor. See, e.g., Mantyjärvi at 3:30-4:2 (“It is an aim of the embodiments of the present invention to address one or several of the disadvantages of the prior art terminals and to provide a new type of solution for controlling one or several functions of a terminal.”); Fukiharu 598 at Abstract (“The object of the present invention is to provide a mobile telephone with a lighting device, and a method for controlling said lighting device, with improved portability through reducing the weight and volume of the battery, and to enable a thorough increase in talk time and standby time, through controlling, through a touch sensor that is provided on a receiver portion surface of the mobile telephone, operation of a lighting device (backlight) of a liquid crystal display device and/or a key pad portion.”). More particularly both Mantyjärvi and Fukiharu 598 disclose turning off the display of a mobile station based on signals from a proximity sensor indicating that a user’s face or ear is in close proximity to the mobile station. See, e.g., Mantyjärvi at Claim 1 (“A terminal for a communication system, the terminal comprising detector means that are arranged to detect a contact between at least one surface of the terminal and the skin of the user of the terminal, wherein at least one function of the terminal is controlled based on a signal from the detecting means.”), Mantyjärvi at Claim 8 (“A terminal according to any of the preceding claims, wherein the operation of a display of the terminal is controlled based on the signal from the detector means.”), Mantyjärvi at Claim 11 (“A terminal according to any of the preceding claims, wherein the detector means are arranged to sense a contact between the terminal and the cheek and/or ear of the user.”); Fukiharu 598 at ¶0015 (“At this time, the lighting-ON state is maintained if not in the voice communication mode. If in the voice communication mode, a touch sensor 2c is placed into an operating state by a signal from the controlling portion 2a, and

	<p>constantly outputs a detection output to the controlling portion 2a. If the touch sensor 2c contacts a portion of the human body, such as an ear, a lighting-OFF signal is outputted to the lighting device ON/OFF circuit portion 2b from the controlling portion 2a through the ON output of the touch sensor 2c, and the power supplies to both the lighting device (backlight) 3a and the lighting device (backlight) 4a go to the OFF state, and this lighting-OFF state is maintained until the touch sensor 2c goes into a non-contact state.”). A person of ordinary skill in the art at the time of the alleged invention would therefore understand that both Mantyjärvi and Fukiharu 598 disclose ways of conserving battery power by shutting of the display of a mobile station at such times that the user of the mobile station is unlikely to be looking at the display (as indicted by at least a proximity sensor). A person of ordinary skill in the art at the time of the alleged invention would be therefore be motivated to modify Mantyjärvi such that “the proximity sensor is a mechanical proximity sensor, an optical sensor, or a range-detecting sensor,” as disclosed in Fukiharu 598 for a number of different reasons, including that it would support Mantyjärvi’s ability to conserve battery power in mobile stations. Doing so would further support Mantyjärvi’s ability to provide means for “controlling of at least one function of a terminal of a communication system” (Mantyjärvi at 1:5-6) where the “sensitivity of the control unit of the mobile station can be adjusted in accordance with specific requirements and/or conditions and may vary if the requirements and/or conditions change.” Mantyjärvi at 14:13-16. Doing so would be within the knowledge and ability of a person of ordinary skill in the art at the time of the alleged invention. The combination would constitute, at least, combining prior art elements according to known methods to yield predictable results, a simple substitution of one known element for another to obtain predictable results, the use of a known technique to improve similar devices in the same way, the application of a known technique to a known device ready for improvement to yield a predictable result, and obvious to try.</p>
<p>[Claim 6] The mobile station as recited in claim 1, wherein the proximity sensor is located proximate to the display.</p>	<p>Mantyjärvi discloses that the proximity sensor is located proximate to the display.</p> <p>For example:</p>

“The electrodes or sensors can be arranged in many alternative ways on the surface of the mobile station 1. For example, one of the electrodes could be positioned on one side surface of the station like the electrode 7 (or 8) of Figure 1 while another electrode could be placed on the opposite side surface of the mobile station or on the back or front surface of the mobile station. It may be difficult in some instances to measure the GSR response by only two electrodes, for example because different users tend to hold the mobile station in different ways.

Therefore it may be advantageous to provide the terminal with more than two electrodes. The electrodes may also be positioned in an appropriate array. Figure 3 shows one possibility for such an array, even though there are various different alternatives for this. The array of the electrodes could be placed, for example, on the back surface of the mobile station.

According to an alternative the mobile station or some parts thereof is covered with an electrically conductive material, such as a metallic coating, and an appropriate isolation is provided between the various parts of the cover. The material of the housing 11 itself may be made from a conductive material. Thus the housing 11 of the mobile station 1 may also be used as a sensing electrode.” Mäntylä at 8:25-9:18.

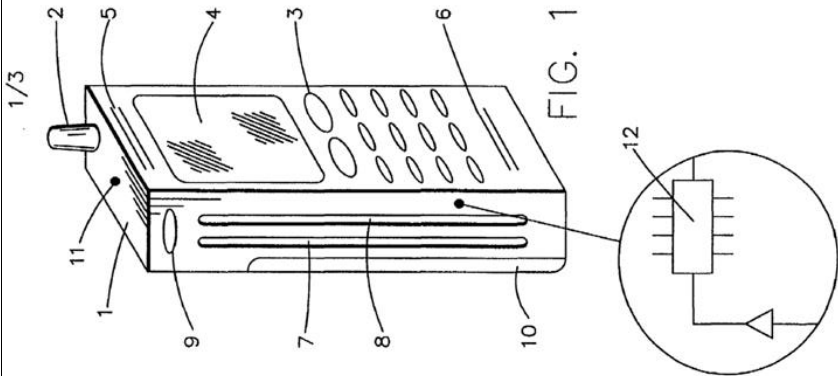

Mantjarvi at Fig. 1.

To the extent Mantjarvi is deemed to not expressly disclose that the proximity sensor is located proximate to the display, Mantjarvi inherently discloses this limitation.

Specifically, a person of ordinary skill in the art at the time of the alleged invention would understand that one or more of the sensors identified in Figs. 4 and 5, as illustrated by Fig. 1 of Mantjarvi necessarily is located proximate to the display. Moreover, it would have been obvious to one of ordinary skill in the art to modify this reference so as to include this claim limitation in light of the knowledge possessed by one of ordinary skill in the art. Further, this claim limitation would have been obvious in light of the other U.S. patents, U.S. patent publications, articles, and products identified in Huawei's

contentions with respect to this limitation, and it would have been obvious to combine these references to a person of ordinary skill in the art, as discussed further in Huawei's invalidity contention cover pleading.

To the extent Mantiyarvi is deemed to not expressly disclose “the proximity sensor is located proximate to the display,” Mantiyarvi inherently discloses this limitation. Mantiyarvi discloses that its invention cuts power to the display during a call when the user has the receiver against his or her ear. A person of ordinary skill in the art at the time of the alleged invention would understand that when a user is holding a mobile station up against their head during a call, the user's ear will make contact with the display and if the proximity sensor is to detect this contact, it necessarily would be “located proximate to the display.” Thus, a person of ordinary skill in the art at the time of the alleged invention would understand Mantiyarvi to inherently disclose that “the proximity sensor is located proximate to the display.”

To the extent Mantiyarvi is deemed to not expressly or inherently disclose “the proximity sensor is located proximate to the display,” Mantiyarvi renders it obvious to one of skill in the art to have “the proximity sensor . . . located proximate to the display.” It would be obvious to a person of ordinary skill in the art at the time of the alleged invention that “the proximity sensor is located proximate to the display” because, in this location, it can detect that the user's head is against the mobile station (and the display). This would constitute, at least, combining prior art elements according to known methods to yield predictable results, a simple substitution of one known element for another to obtain predictable results, the use of a known technique to improve similar devices in the same way, the application of a known technique to a known device ready for improvement to yield a predictable result, and obvious to try.

To the extent Mantiyarvi is deemed to not expressly or inherently disclose that “the proximity sensor is located proximate to the display,” it would be obvious to combine the

disclosure of Mantiyarvi with those of Fukiharu 598 as described in the Fukiharu 598 claim chart, which is incorporated herein in its entirety by reference. Mantiyarvi and Fukiharu 598 are both directed to controlling the functionality of mobile stations based in part on signals from a proximity sensor. See, e.g., Mantiyarvi at 3:30-4:2 (“It is an aim of the embodiments of the present invention to address one or several of the disadvantages of the prior art terminals and to provide a new type of solution for controlling one or several functions of a terminal.”); Fukiharu 598 at Abstract (“The object of the present invention is to provide a mobile telephone with a lighting device, and a method for controlling said lighting device, with improved portability through reducing the weight and volume of the battery, and to enable a thorough increase in talk time and standby time, through controlling, through a touch sensor that is provided on a receiver portion surface of the mobile telephone, operation of a lighting device (backlight) of a liquid crystal display device and/or a key pad portion.”). More particularly both Mantiyarvi and Fukiharu 598 disclose turning off the display of a mobile station based on signals from a proximity sensor indicating that a user’s face or ear is in close proximity to the mobile station. See, e.g., Mantiyarvi at Claim 1 (“A terminal for a communication system, the terminal comprising detector means that are arranged to detect a contact between at least one surface of the terminal and the skin of the user of the terminal, wherein at least one function of the terminal is controlled based on a signal from the detecting means.”), Mantiyarvi at Claim at 8 (“A terminal according to any of the preceding claims, wherein the operation of a display of the terminal is controlled based on the signal from the detector means.”), Mantiyarvi at Claim 11 (“A terminal according to any of the preceding claims, wherein the detector means are arranged to sense a contact between the terminal and the cheek and/or ear of the user.”); Fukiharu 598 at ¶0015 (“At this time, the lighting-ON state is maintained if not in the voice communication mode. If in the voice communication mode, a touch sensor 2c is placed into an operating state by a signal from the controlling portion 2a, and constantly outputs a detection output to the controlling portion 2a. If the touch sensor 2c contacts a portion of the human body, such as an ear, a lighting-OFF signal is outputted to the lighting device ON/OFF circuit portion 2b from the controlling portion 2a through the ON output of the touch sensor 2c, and the power supplies to both the lighting device (backlight) 3a and the lighting device (backlight) 4a go to the OFF state, and this lighting-OFF state is maintained until the touch sensor 2c goes into a non-contact state.”). A person of ordinary skill in the art at the time of the alleged invention would therefore

	<p>understand that both Mantyjärvi and Fukiharu 598 disclose ways of conserving battery power by shutting of the display of a mobile station at such times that the user of the mobile station is unlikely to be looking at the display (as indicted by at least a proximity sensor). A person of ordinary skill in the art at the time of the alleged invention would be therefore be motivated to modify Mantyjärvi such that “the proximity sensor is located proximate to the display,” as disclosed in Fukiharu 598 for a number of different reasons, including that it would support Mantyjärvi’s ability to conserve battery power in mobile stations. Doing so would further support Mantyjärvi’s ability to provide means for “controlling of at least one function of a terminal of a communication system” (Mantyjärvi at 1:5-6) where the “sensitivity of the control unit of the mobile station can be adjusted in accordance with specific requirements and/or conditions and may vary if the requirements and/or conditions change.” Mantyjärvi at 14:13-16. Doing so would be within the knowledge and ability of a person of ordinary skill in the art at the time of the alleged invention. The combination would constitute, at least, combining prior art elements according to known methods to yield predictable results, a simple substitution of one known element for another to obtain predictable results, the use of a known technique to improve similar devices in the same way, the application of a known technique to a known device ready for improvement to yield a predictable result, and obvious to try.</p>
<p>[Claim 8 – Preamble] 8. A method of conserving battery power in a mobile station, comprising:</p>	<p>To the extent the preamble is construed as limiting, Mantyjärvi discloses a method of conserving battery power in a mobile station.</p> <p>For example: <i>see</i> discussion of claim 1, <i>supra</i>, which is incorporated herein by reference.</p>
<p>[8a] detecting whether an external object is proximate;</p>	<p>Mantyjärvi discloses detecting whether an external object is proximate:</p> <p>For example: <i>see</i> discussion of claim element [1b], <i>supra</i>, which is incorporated herein by reference.</p>

	<p>Mantjarvi discloses determining whether a telephone call is active.</p> <p>For example: <i>see</i> discussion of claim element [1d], <i>supra</i>, which is incorporated herein by reference.</p> <p>To the extent Mantjarvi is deemed to not expressly disclose this claim limitation, Mantjarvi inherently discloses this limitation. <i>See</i> discussion of claim element [1d], <i>supra</i>, which is incorporated herein by reference.</p> <p>To the extent Mantjarvi is deemed to not expressly or inherently disclose this claim limitation, Mantjarvi renders it obvious to one of skill in the art at the time of the alleged invention. <i>See</i> discussion of claim element [1d], <i>supra</i>, which is incorporated herein by reference.</p> <p>To the extent Mantjarvi is deemed to not expressly or inherently disclose this claim element, it would be obvious to combine the disclosure of Mantjarvi with those of Fukiharu 598 as described in the Fukiharu 598 claim chart, which is incorporated herein in its entirety by reference. <i>See</i> discussion of claim element [1d], <i>supra</i>, which is incorporated herein by reference.</p>
<p>[8b] determining whether a telephone call is active; and</p>	
<p>[8c] reducing power consumption of a display of the mobile station if (i) a telephone call is determined to be active and (ii) the proximity of the external object is detected; wherein:</p>	<p>Mantjarvi discloses reducing power consumption of a display of the mobile station if (i) a telephone call is determined to be active and (ii) the proximity of the external object is detected.</p> <p>For example: <i>see</i> discussion of claim element [1f], <i>supra</i>, which is incorporated herein by reference.</p>

	<p>To the extent Mantyjärvi is deemed to not expressly disclose this claim limitation, Mantyjärvi inherently discloses this limitation. <i>See</i> discussion of claim element [1h], <i>supra</i>, which is incorporated herein by reference.</p> <p>To the extent Mantyjärvi is deemed to not expressly or inherently disclose this claim limitation, Mantyjärvi renders it obvious to one of skill in the art at the time of the alleged invention. <i>See</i> discussion of claim element [1h], <i>supra</i>, which is incorporated herein by reference.</p> <p>To the extent Mantyjärvi is deemed to not expressly or inherently disclose this claim element, it would be obvious to combine the disclosure of Mantyjärvi with those of Fukiharu 598 as described in the Fukiharu 598 claim chart, which is incorporated herein in its entirety by reference. <i>See</i> discussion of claim element [1h], <i>supra</i>, which is incorporated herein by reference.</p>
<p>[8d] the telephone call is a wireless telephone call;</p>	<p>Mantyjärvi discloses that the telephone call is a wireless telephone call:</p> <p><i>See</i> discussion of claim element [1g], <i>supra</i>, which is incorporated herein by reference.</p>
<p>[8e] the power consumption of the display is reduced while the proximity of the external object is detected only if the wireless telephone call is determined to be active; and</p>	<p>Mantyjärvi discloses that the power consumption of the display is reduced while the proximity of the external object is detected only if the wireless telephone call is determined to be active.</p> <p>For example: <i>see</i> discussion of claim element [1h], <i>supra</i>, which is incorporated herein by reference.</p> <p>To the extent Mantyjärvi is deemed to not expressly disclose this claim limitation, Mantyjärvi inherently discloses this limitation. <i>See</i> discussion of claim element [1h], <i>supra</i>, which is incorporated herein by reference.</p> <p>To the extent Mantyjärvi is deemed to not expressly or inherently disclose this claim limitation, Mantyjärvi renders it obvious to one of skill in the art at the time of the alleged</p>

	<p>invention. <i>See</i> discussion of claim element [1h], <i>supra</i>, which is incorporated herein by reference.</p> <p>To the extent Mantyjärvi is deemed to not expressly or inherently disclose this claim element, it would be obvious to combine the disclosure of Mantyjärvi with those of Fukiharu 598 as described in the Fukiharu 598 claim chart, which is incorporated herein in its entirety by reference. <i>See</i> discussion of claim element [1h], <i>supra</i>, which is incorporated herein by reference.</p>
<p>[8f] detecting whether an external object is proximate begins substantially concurrently with the mobile station initiating an outgoing wireless telephone call or receiving an incoming wireless telephone call.</p>	<p>Mantyjärvi discloses that detecting whether an external object is proximate begins substantially concurrently with the mobile station initiating an outgoing wireless telephone call or receiving an incoming wireless telephone call.</p> <p>For example: <i>see</i> discussion of claim element [1i], <i>supra</i>, which is incorporated herein by reference.</p> <p>To the extent Mantyjärvi is deemed to not expressly disclose this claim limitation, Mantyjärvi inherently discloses this limitation. <i>See</i> discussion of claim element [1i], <i>supra</i>, which is incorporated herein by reference.</p> <p>To the extent Mantyjärvi is deemed to not expressly or inherently disclose this claim limitation, Mantyjärvi renders it obvious to one of skill in the art at the time of the alleged invention. <i>See</i> discussion of claim element [1i], <i>supra</i>, which is incorporated herein by reference.</p> <p>To the extent Mantyjärvi is deemed to not expressly or inherently disclose this claim element, it would be obvious to combine the disclosure of Mantyjärvi with those of Fukiharu 598 as described in the Fukiharu 598 claim chart, which is incorporated herein in its entirety by reference. <i>See</i> discussion of claim element [1i], <i>supra</i>, which is incorporated herein by reference.</p>

<p>[Claim 12] The method as recited in claim 8, wherein the detecting of the proximity of the external object is performed by a mechanical proximity sensor, an optical sensor, or a range-detecting sensor.</p>	<p>Mantjarvi discloses that the detecting of the proximity of the external object is performed by a mechanical proximity sensor, an optical sensor, or a range-detecting sensor:</p> <p><i>See</i> discussion of claim 5, <i>supra</i>, which is incorporated herein by reference.</p> <p>To the extent Mantjarvi is deemed to not expressly disclose this claim limitation, Mantjarvi inherently discloses this limitation. <i>See</i> discussion of claim 5, <i>supra</i>, which is incorporated herein by reference.</p> <p>To the extent Mantjarvi is deemed to not expressly or inherently disclose this claim limitation, Mantjarvi renders it obvious to one of skill in the art at the time of the alleged invention. <i>See</i> discussion of claim 5, <i>supra</i>, which is incorporated herein by reference.</p> <p>To the extent Mantjarvi is deemed to not expressly or inherently disclose this claim element, it would be obvious to combine the disclosure of Mantjarvi with those of Fukiharu 598 as described in the Fukiharu 598 claim chart, which is incorporated herein in its entirety by reference. <i>See</i> discussion of claim 5, <i>supra</i>, which is incorporated herein by reference.</p>
--	--

Exhibit A7

**Exhibit A7-Sparre
to Defendants' Preliminary Invalidity Contentions**

**Invalidity Chart for U.S. Patent No. 7,319,889
World Intellectual Property Organization Publication No. WO 00/78012 (“Sparre”)**

World Intellectual Property Organization Publication No. WO 00/78012 to Sparre (“Sparre”). Sparre was filed on June 8, 2000 and published on December 21, 2000. Sparre is prior art to the '889 Patent under at least pre-AIA §§ 102(b) and 102(e). Sparre anticipates or renders obvious, alone or in combination with other prior art references, each of the Asserted Claims of the '889 Patent as described in the chart below and in the main invalidity contentions document to which this chart is annexed.

It would have been obvious under 35 U.S.C. § 103 to a person having ordinary skill in the art at the time of the alleged invention to combine the teachings of Sparre with the following references:

1. Japanese Unexamined Patent Application Publication No. 2000-106598 to Fukiharu (“Fukiharu 598”). Fukiharu 598 qualifies as prior art under at least pre-AIA §§ 102(a), 102(b), and 102(e). Fukiharu 598 was published on April 11, 2000.

<u>Asserted Claims</u>	<u>Corresponding Disclosure in the Prior Art Reference(s)</u>
[Claim 1 – Preamble] 1. A mobile station, comprising:	<p>Sparre discloses a mobile station.</p> <p>For example:</p> <p>“Examples of portable electric apparatuses as set out above are for instance mobile or cellular telephones, wireless telephone handsets, personal communicators, portable digital assistants, palmtop computers, etc. The users thereof are dependent of a fully functional apparatus. More specifically, one of the most common problems in this respect is the limited operational duration between subsequent chargings of a battery used for supplying power to the apparatus. While it has been possible to reach reduced power consumption through the development of low-voltage, high-density integrated circuits, battery capacity is still a major obstacle against full user freedom in terms of virtually unlimited operational duration. Consequently, preservation of electric power is still a very important issue within the field of portable electric apparatuses. For the rest of this document, reference is made to a mobile telephone, which is chosen to</p>

represent a portable electric apparatus according to the invention. However, the invention shall in no way be limited to merely a mobile telephone. In a mobile telephone, the liquid crystal display (LCD) is responsible for a significant part of the total power consumption thereof.” Sparre at 1-2.

“An example of a portable electric apparatus is given in FIG 1 in the form of a mobile telephone 1 having a housing 10, an antenna 2 mounted on top of the housing, a status indicator LED 3, a speaker 4, volume adjustment controls 5, an LCD display 6 and a keypad 7. The keypad 7 has a plurality of individual keys, such as a YES button 12 and a NO button 13, arrow keys 14, 15, a clear key 16, numeric keys 17 (labeled 0 through 9), a star key 18 and a hash key 19.” Sparre at 8.

“FIG 1 is a schematic front view of a portable electric apparatus, exemplified as a mobile telephone, having a liquid crystal display and a proximity detector according to the invention.” Sparre at 7-8.

1/2

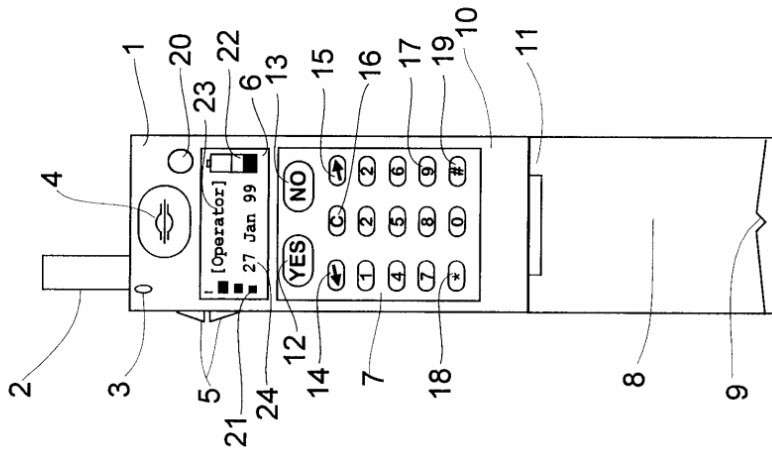
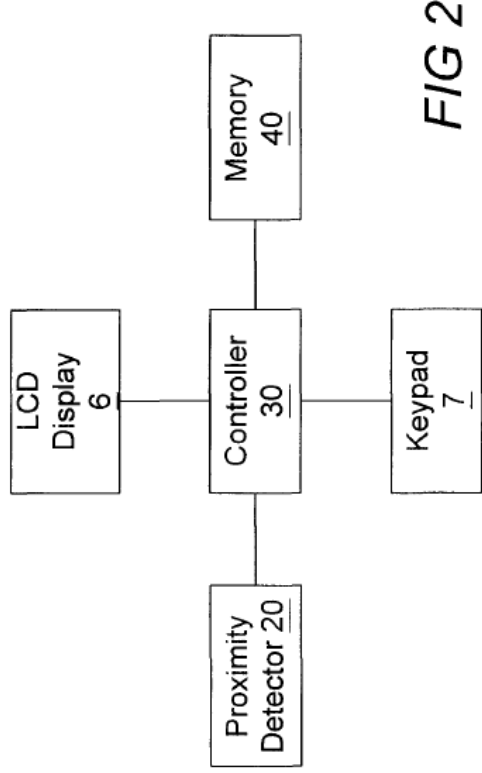

FIG 1

Sparre at Fig. 1.

“The main components of the mobile telephone 1 are shown in FIG 2. A controller 30 is operatively connected to the display 6, the keypad 7, the proximity detector 20 and a memory 40. The controller 30 may be any microprocessor, central processing unit (CPU) or other piece of electronic logic circuitry already used in the telephone 1 for performing the various functions thereof (such as telephone call control, keypad control, display control, or execution of utility programs such as a calculator program, electronic game programs, etc) . Alternatively, the controller 30 may be realized by

separate electronic logic circuitry, which in itself is generally known, such as a microprocessor, an integrated circuit network, etc. Correspondingly, the memory 40 may be of any type generally known within the field of portable electric apparatuses, such as an EEPROM memory, a RAM memory, a flash memory etc.” Sparre at 10-11.



Sparre at Fig. 2.

“10. A portable electric apparatus (1) according to any preceding claim, wherein the apparatus is a telecommunication device, preferably a mobile telephone (1).” Sparre at Claim 10.

[1a] a display;

Sparre discloses a display.

For example:

“FIG 1 is a schematic front view of a portable electric apparatus, exemplified as a mobile telephone, having a liquid crystal display and a proximity detector according to the invention.” Sparre at 7-8.

“An example of a portable electric apparatus is given in FIG 1 in the form of a mobile telephone 1 having a housing 10, an antenna 2 mounted on top of the housing, a status indicator LED 3, a speaker 4, volume adjustment controls 5, an LCD display 6 and a keypad . . . The liquid crystal display 6 is arranged according to the description in the Prior Art section of this document, i.e. comprises two glass plates with a layer of liquid crystals provided between them, together with a control line matrix placed on either sides of the two glass plates. As previously described, the graphical information presented on the display 6 is controlled by supplying electric energy from the display driver through the control line matrix to the liquid crystal layer. The display 6 is shown in an active state in FIG 1 and comprises graphical symbols or icons for presenting a received signal strength indicator 21, a remaining battery charge indicator 22, information about the active network operator 23 as well as the current date 24. Consequently, the liquid crystal display 6 consumes a certain amount of electric energy, depending on the supply of electric energy to the liquid crystal layer.” Sparre at 8-9.

“The liquid crystal display 6 also has an inactive state, where less or even no electric energy is supplied to the liquid crystal layer and, thus, less visual information is presented on the display. In contrast to the active state, during which all graphical information (e.g. the icons 21-24) is presented on the display, only parts of this graphical information is shown on the display during its inactive state. For instance, with reference to FIG 1, only the remaining battery charge indicator 22 (but not the icons 21, 22 or 24) is presented on the display 6 during its inactive state. Such an inactive state essentially corresponds to the "limited icon mode", which was described in the Prior Art section of this document. Alternatively, the liquid crystal display 6 may be completely turned off in its inactive state (i.e., no electric energy is supplied to the

<p>liquid crystal layer, wherein the power consumption of the display is essentially zero).” Sparre at 9.</p> <p>“A proximity detector is provided at the uppermost portion of the front surface of the telephone 1. In the embodiment shown in FIG 1, the proximity detector 20 is located immediately above the display 6 next to the speaker 4. However, the exact location of the proximity detector 20 is not critical but may be varied between many different positions, as long as the functional requirements specified below are satisfied.” Sparre at 9.</p>	
---	--

1/2

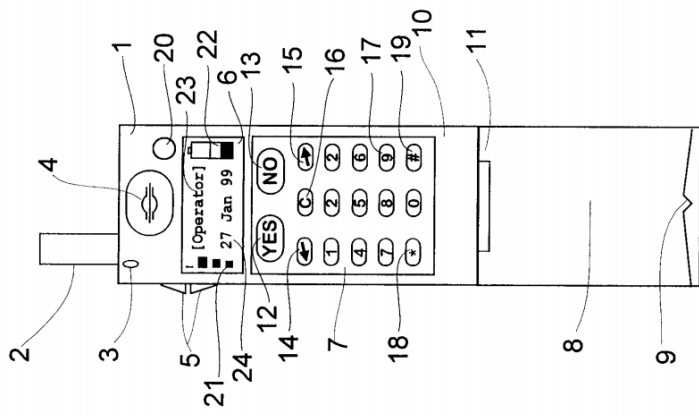

FIG 1

Sparre at Fig. 1.

“The main components of the mobile telephone 1 are shown in FIG 2. A controller 30 is operatively connected to the display 6, the keypad 7, the proximity detector 20 and a memory 40.” Sparre at 10.

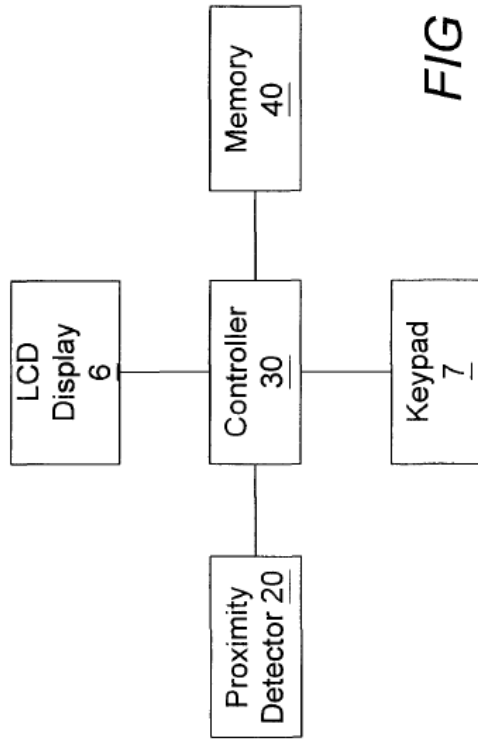

FIG 2

Sparre at Fig. 2.

“Together with the proximity detector 20, the controller 30 is arranged to bring the liquid crystal display 6 into its inactive state, whenever an external object is detected in proximity with the portion of the telephone 1, where the display is located. This functionality is referred to as Proximity Sleep Mode in the following.

According to one embodiment the man-machine interface of the mobile telephone 1 has an option for allowing the user to disable the Proximity Sleep Mode functionality, so that the display 6 is not turned off, even if an external object is detected by the proximity detector 20. The reason why the user should be given an opportunity to disable this feature is to prevent the display from accidentally being turned off, when the mobile telephone is carried in for instance a protective cover bag. Information regarding whether the Proximity Sleep Mode feature has been disabled by the user is preferably stored as a settings parameter in the memory 40.” Sparre at 11.

“If the answer of step 130 is in the affirmative, the controller 30 forces the liquid crystal display 6 to enter its inactive state in a subsequent step 150. As previously mentioned, the inactive state may either involve displaying only a limited set of icons (such as the remaining battery charge indicator 22), or completely turning off the liquid crystal display 6 by stop supplying electric energy to the liquid crystal layer. The first case is represented by a step 155b in FIG 3, whereas the second case is represented by steps 155a and 157a. Following the last step (i.e., either step 155b or step 157a) the control is transferred back to the beginning of routine 100. If, on the other hand, no external object has been detected in step 130, the controller 30 causes the liquid crystal display 6 to enter its active state, provided that the display 6 is not already active, in a step 140. When step 140 has been completed, the control is transferred back to the beginning of routine 100. In this way, an endless loop is formed by steps 100, 110, 120, 130, 140, 150 and 155b and 155a, 157a, respectively. Consequently, the presence of an external object in proximity with the proximity detector 20 will be continuously monitored, and in response to detecting such an external object, the display 6 will be set to its active state, thereby saving electric power. Furthermore, if the external object disappears from the proximity detector 20, the display 6 is again set to its active state in step 140.

Preferably, the endless Proximity Sleep Mode routine 100 may be interrupted by the controller 30 (pre-emptive scheduling) , so that other tasks with higher priority may be executed instead of routine 100. For instance, as soon as the controller 30 has detected that the user has started initiating an outgoing call, the routine 100 is temporarily stopped and the display 6 is activated, thereby avoiding an undesired situation where e.g. the hand or head of the user is accidentally detected by the proximity detector 20, while the telephone number to be called is entered on the keypad 7.” Sparre at 12-13.

“The invention may also be combined with known power preservation arrangements, such as automatically turning off the display backlighting after certain time, as described in previous sections.” Sparre at 13.

<p>[1b] a proximity sensor adapted to generate a signal indicative of proximity of an external object; and</p>	<p>Sparre discloses a proximity sensor adapted to generate a signal indicative of proximity of an external object.</p> <p>For example:</p> <p>“A portable electric apparatus (1) has a display (6) of the type comprising a liquid crystal layer. The display has an active state for presenting visual information in response to a supply of electric energy to the liquid crystal layer. The display also has an inactive state, in which less electric energy is supplied to the liquid crystal layer and less visual information consequently is presented. The apparatus (1) also has a proximity detector (20) for detecting the presence of an object in proximity with the apparatus and in response causing the display (6) to enter its inactive state.” Sparre at Abstract.</p> <p>“Therefore, when the proximity detector has detected the presence of the external object, the display may be powered off or present less visual information. More specifically, the purpose above has been achieved for a portable electric apparatus having a display of the type comprising a liquid crystal layer, wherein the display has an active state for presenting visual information in response to a supply of electric energy to the liquid crystal layer, and wherein the display also has an inactive state, in which less electric energy is supplied to the liquid crystal layer and less visual information consequently is presented, by the provision of a proximity detector for detecting the presence of an object in proximity with the apparatus and in response causing the display to enter its inactive state.</p> <p>The purpose has also been achieved through a method of preserving power for a portable electric apparatus having a display of the type comprising a liquid crystal layer, the display having an active state for presenting visual information in response to a supply of electric energy to the liquid crystal layer, the display also having an inactive state, in which less electric energy is supplied to the liquid crystal layer and less visual information consequently is presented, by the steps of determining whether an</p>
--	---

object is present in proximity with the apparatus, and, if so, causing the display to enter its inactive state.” Sparre at 6-7.

“A proximity detector is provided at the uppermost portion of the front surface of the telephone 1. In the embodiment shown in FIG 1, the proximity detector 20 is located immediately above the display 6 next to the speaker 4. However, the exact location of the proximity detector 20 is not critical but may be varied between many different positions, as long as the functional requirements specified below are satisfied.

In one embodiment, the proximity detector 20 is an IR (infrared) detector, which is arranged to emit infrared light from the front surface of the telephone 1 and is arranged to detect infrared light, that has been reflected from an external object located close to the upper portion of front surface of the telephone 1. Hence, as is generally known per se, the proximity detector 20 may measure the intensity of the reflected infrared light and in response determine whether any external object is present in proximity with the detector 20. By establishing a predetermined threshold for the fraction of infrared light reflected back to the proximity detector 20, it is possible to define a predetermined range, within which any external object will be detected by the proximity detector 20. Obviously, such a threshold will depend on i.a. the surface structure and material of the external object in question. However, such an issue is regarded nothing more than a practical parameter, which in an actual application will have to be tested, evaluated and determined by a skilled person. Proximity detectors as such are generally known and are commercially available on the market in large numbers .

According to an alternative embodiment, if the mobile telephone is equipped with an IR interface for wireless data communication with external devices (such as a handheld computer), the IR transmitter thereof may be used also for the purpose of transmitting IR light to be detected by the proximity detector 20.

Alternatively, the proximity detector 20 may operate by emitting and detecting visible light, by detecting thermal energy generated by the external object, or by detecting the external object by capacitive means.” Sparre at 9-10.

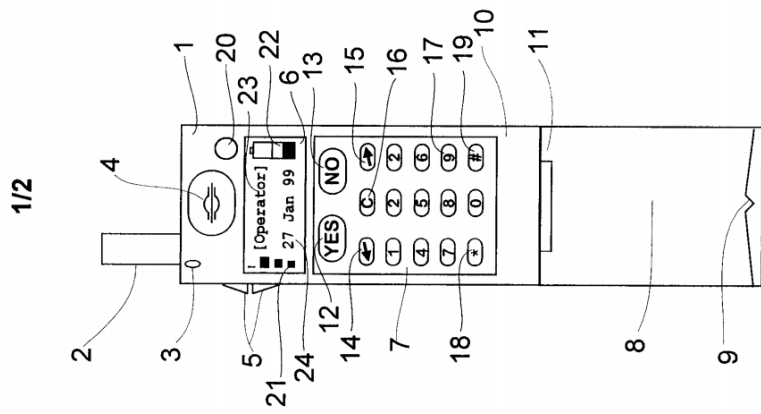

FIG 1

Sparre at Fig. 1.

“The main components of the mobile telephone 1 are shown in FIG 2. A controller 30 is operatively connected to the display 6, the keypad 7, the proximity detector 20 and a memory 40.” Sparre at 10.

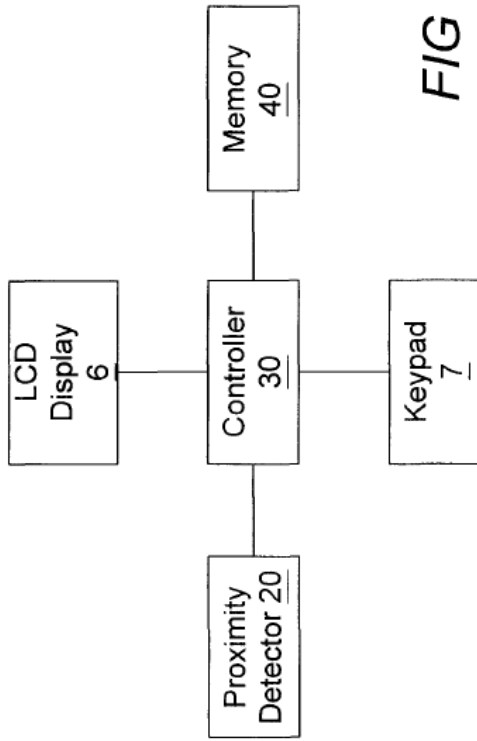

FIG 2

Sparre at Fig. 2.

“Together with the proximity detector 20, the controller 30 is arranged to bring the liquid crystal display 6 into its inactive state, whenever an external object is detected in proximity with the portion of the telephone 1, where the display is located. This functionality is referred to as Proximity Sleep Mode in the following.” Sparre at 11.

“FIG 3 illustrates a Proximity Sleep Mode routine 100, which according to one embodiment is regularly executed by the controller 30. After the initial step 100 the controller 30 determines, in step 110, whether the Proximity Sleep Mode feature has been disabled by the user. If the answer is in the affirmative, the control is immediately

returned to the beginning of routine 100. If, on the other hand, the Proximity Sleep Mode feature has not been disabled by the user, then the output from the proximity detector 20 is read in step 120. In step 130, the value of the output retrieved in step 120 is examined, so as to determine whether any external object is present in proximity with the proximity detector 20 and, consequently, the mobile telephone 1. Preferably, it is required in steps 120 and 130 that the presence of the external object is continuously detected for a certain period of time, before it is ultimately concluded that the display is indeed blocked by an external object. In this way, rapid hand movements, etc., past the display will not accidentally turn off the display.

If the answer of step 130 is in the affirmative, the controller 30 forces the liquid crystal display 6 to enter its inactive state in a subsequent step 150. As previously mentioned, the inactive state may either involve displaying only a limited set of icons (such as the remaining battery charge indicator 22), or completely turning off the liquid crystal display 6 by stop supplying electric energy to the liquid crystal layer. The first case is represented by a step 155b in FIG 3, whereas the second case is represented by steps 155a and 157a. Following the last step (i.e., either step 155b or step 157a) the control is transferred back to the beginning of routine 100. If, on the other hand, no external object has been detected in step 130, the controller 30 causes the liquid crystal display 6 to enter its active state, provided that the display 6 is not already active, in a step 140. When step 140 has been completed, the control is transferred back to the beginning of routine 100. In this way, an endless loop is formed by steps 100, 110, 120, 130, 140, 150 and 155b and 155a, 157a, respectively. Consequently, the presence of an external object in proximity with the proximity detector 20 will be continuously monitored, and in response to detecting such an external object, the display 6 will be set to its active state, thereby saving electric power. Furthermore, if the external object disappears from the proximity detector 20, the display 6 is again set to its active state in step 140.” Sparre at 11-13.

“1. A portable electric apparatus (1) having a display (6) of the type comprising a liquid crystal, the display having an active state for presenting visual information in response to a supply of electric energy to the liquid crystal layer, the display also having an

	<p>inactive state, in which less electric energy is supplied to the liquid crystal layer and less visual information consequently is presented, characterized by a proximity detector (20) for detecting the presence of an object in proximity with the apparatus (1) and in response causing the display (6) to enter its inactive state.</p> <p>2. A portable electric apparatus (1) according to claim 1, wherein the proximity detector (20) operates by detecting infrared (IR) light.</p> <p>3. A portable electric apparatus (1) according to claim 1, wherein the proximity detector (20) operates by detecting visible light .</p> <p>4. A portable electric apparatus (1) according to claim 1, wherein the proximity detector (20) operates by detecting thermal energy generated by said object.</p> <p>5. A portable electric apparatus (1) according to claim 1, wherein the proximity detector (20) operates by detecting said object by capacitive means.” Sparre at Claims 1-5.</p> <p>“11. A method of preserving power for a portable electric apparatus (1) having a display (6) of the type comprising a liquid crystal layer, the display having an active state for presenting visual information in response to a supply of electric energy to the liquid crystal layer, the display also having an inactive state, in which less electric energy is supplied to the liquid crystal layer and less visual information consequently is presented, characterized by the steps of determining whether an object is present in proximity with the apparatus (1) , and, if so, causing the display (6) to enter its inactive state.” Sparre at Claim 11.</p>
<p>[1c] a microprocessor adapted to:</p>	<p>Sparre discloses a microprocessor.</p> <p>For example:</p>

“The main components of the mobile telephone 1 are shown in FIG 2. A controller 30 is operatively connected to the display 6, the keypad 7, the proximity detector 20 and a memory 40. The controller 30 may be any microprocessor, central processing unit (CPU) or other piece of electronic logic circuitry already used in the telephone 1 for performing the various functions thereof (such as telephone call control, keypad control, display control, or execution of utility programs such as a calculator program, electronic game programs, etc) . Alternatively, the controller 30 may be realized by separate electronic logic circuitry, which in itself is generally known, such as a microprocessor, an integrated circuit network, etc. Correspondingly, the memory 40 may be of any type generally known within the field of portable electric apparatuses, such as an EEPROM memory, a RAM memory, a flash memory etc.” Sparre at 10-11.

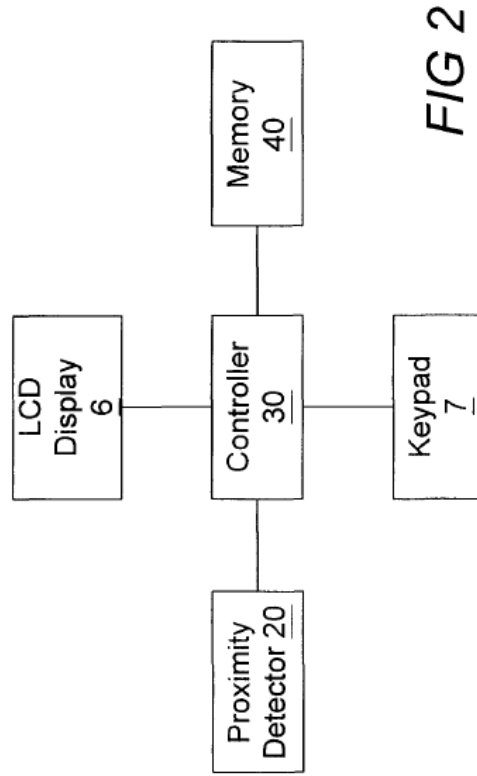

Sparre at Fig. 2.

FIG 2

<p>[1d] (a) determine whether a telephone call is active;</p>	<p>FIG 3 illustrates a Proximity Sleep Mode routine 100, which according to one embodiment is regularly executed by the controller 30. Sparre at 11.</p>
<p>Sparre discloses the microprocessor adapted to determine whether a telephone call is active.</p> <p>For example: “</p> <p>“A portable electric apparatus (1) has a display (6) of the type comprising a liquid crystal layer. The display has an active state for presenting visual information in response to a supply of electric energy to the liquid crystal layer. The display also has an inactive state, in which less electric energy is supplied to the liquid crystal layer and less visual information consequently is presented. The apparatus (1) also has a proximity detector (20) for detecting the presence of an object in proximity with the apparatus and in response causing the display (6) to enter its inactive state.” Sparre at Abstract.</p> <p>“The present invention relates to a portable electric apparatus having a display of the type comprising a liquid crystal layer, the display having an active state for presenting visual information in response to a supply of electric energy to the liquid crystal layer, the display also having an inactive state, in which less electric energy is supplied to the liquid crystal layer and less visual information consequently is presented. More specifically, the invention is directed at a new and inventive way of preserving electric power in such a portable electric apparatus by bringing the display to its inactive state whenever appropriate. The invention also relates to a method of preserving power for such an apparatus.” Sparre at 1.</p> <p>“The highest power consumption for a liquid crystal display occurs when an event takes place in the telephone, for instance when a telephone call is generated or ended. In those situations, the visibility of the LCD display is amplified by turning on a back-light illumination of the display. Such back-light illumination consumes too much</p>	<p>Sparre discloses the microprocessor adapted to determine whether a telephone call is active.</p> <p>For example: “</p> <p>“A portable electric apparatus (1) has a display (6) of the type comprising a liquid crystal layer. The display has an active state for presenting visual information in response to a supply of electric energy to the liquid crystal layer. The display also has an inactive state, in which less electric energy is supplied to the liquid crystal layer and less visual information consequently is presented. The apparatus (1) also has a proximity detector (20) for detecting the presence of an object in proximity with the apparatus and in response causing the display (6) to enter its inactive state.” Sparre at Abstract.</p> <p>“The present invention relates to a portable electric apparatus having a display of the type comprising a liquid crystal layer, the display having an active state for presenting visual information in response to a supply of electric energy to the liquid crystal layer, the display also having an inactive state, in which less electric energy is supplied to the liquid crystal layer and less visual information consequently is presented. More specifically, the invention is directed at a new and inventive way of preserving electric power in such a portable electric apparatus by bringing the display to its inactive state whenever appropriate. The invention also relates to a method of preserving power for such an apparatus.” Sparre at 1.</p> <p>“The highest power consumption for a liquid crystal display occurs when an event takes place in the telephone, for instance when a telephone call is generated or ended. In those situations, the visibility of the LCD display is amplified by turning on a back-light illumination of the display. Such back-light illumination consumes too much</p>

power than what is acceptable in a long-term perspective. Therefore, back- light illumination is normally restricted to a short time period of a few seconds around the respective event, such as the entering of a telephone number on the keypad, the reception of an incoming call or the termination of an ongoing call (on-hook).” Sparre at 3.

“US-A-5 881 377 discloses a radio telephone with a power-saving arrangement, which is adapted to detect the presence of the radio telephone in proximity with an ear of a user and which also is adapted to turn off a display of the radio telephone. Aforesaid arrangement may be of a type capable of detecting heat, or comprise an opto-electric switch. The display of the radio telephone is of a type comprising light emitting diodes (LED). According to an alternative embodiment of US-A-5 881 377, the display is a liquid crystal display, and a light emitting diode is provided for backlighting the LCD-display. In this embodiment, the backlighting LED, but not the actual liquid crystal display, is switched on and off for saving electric power in response to whether or not the radio telephone is kept near the user’s head.” Sparre at 5.

The purpose of these inventions is to save electric power when the telephone is kept close to the user (i.e. in proximity with the user’s ear in talking position).” Sparre at 6.

“A foldable flip 8 is swingably mounted to the apparatus housing 10 by means of a hinge mechanism 11. The flip 8 comprises a sound opening 9, through which vocal sound is received from the user of the telephone and forwarded to an internal microphone (not shown in the drawing).” Sarre at 9.

“The controller 30 may be any microprocessor, central processing unit (CPU) or other piece of electronic logic circuitry already used in the telephone 1 for performing the

various functions thereof (such as telephone call control, keypad control, display control, or execution of utility programs such as a calculator program, electronic game programs, etc).” Sparre at 10-11.

“Preferably, the endless Proximity Sleep Mode routine 100 may be interrupted by the controller 30 (pre-emptive scheduling), so that other tasks with higher priority may be executed instead of routine 100. For instance, as soon as the controller 30 has detected that the user has started initiating an outgoing call, the routine 100 is temporarily stopped and the display 6 is activated, thereby avoiding an undesired situation where e.g. the hand or head of the user is accidentally detected by the proximity detector 20, while the telephone number to be called is entered on the keypad 7.

Correspondingly, routine 100 may be temporarily aborted upon detection of an incoming telephone call, text message (SMS; Short Messages Services), etc.” Sparre at 13.

“The invention may also be combined with known power preservation arrangements, such as automatically turning off the display backlighting after certain time, as described in previous sections.” Sparre at 13.

“10. A portable electric apparatus (1) according to any preceding claim, wherein the apparatus is a telecommunication device, preferably a mobile telephone (1).” Sparre at claim 10.

“12. A method according to claim 11, comprising an initial step of determining whether a user of the apparatus has chosen to disable the execution of the steps in claim 11, wherein the steps of claim 12 are only executed, if no such choice has been made by the user.” Sparre at claim 11.

To the extent Sparre is deemed to not expressly disclose the microprocessor adapted to “determine whether a telephone call is active,” Sparre inherently discloses this limitation. For example, Sparre discloses that the normal routine of detecting via the proximity sensor can be temporarily halted by the microprocessor under certain circumstances such as detecting that the user is dialing a number. *See* Sparre at 13 (“Preferably, the endless Proximity Sleep Mode routine 100 may be interrupted by the controller 30 (pre-emptive scheduling), so that other tasks with higher priority may be executed instead of routine 100. For instance, as soon as the controller 30 has detected that the user has started initiating an outgoing call, the routine 100 is temporarily stopped and the display 6 is activated, thereby avoiding an undesired situation where e.g. the hand or head of the user is accidentally detected by the proximity detector 20, while the telephone number to be called is entered on the keypad 7. Correspondingly, routine 100 may be temporarily aborted upon detection of an incoming telephone call, text message (SMS; Short Messages Services), etc.”). A person of ordinary skill in the art at the time of the alleged invention would understand that since Sparre teaches that the microprocessor only temporarily halts the normal routine, the microprocessor would necessarily need to be able “determine whether a telephone call is active” in order to determine the appropriate time to start up the normal routine again. A person of ordinary skill in the art at the time of the alleged invention would have such understanding because they would for example, further understand that once the user of the mobile station is done initiating the outgoing call by dialing keys on the handset they will place the handset next to their head for the duration of the call at which time the proximity detector 20 of Sparre would need to be functioning in order to signal to the microprocessor that the display should be powered down in order for the battery conservation purpose of Sparre to be realized. Therefore, a person of ordinary skill in

the art at the time of the alleged invention would understand that necessarily the microprocessor would “determine whether a telephone call is active.”

To the extent Sparre is deemed to not expressly or inherently disclose the microprocessor adapted to “determine whether a telephone call is active,” Sparre renders it obvious to one of skill in the art to “determine whether a telephone call is active.” For example, Sparre discloses that the normal routine of detecting via the proximity sensor can be temporarily halted by the microprocessor under certain circumstances such as detecting that the user is dialing a number. *See* Sparre at 13 (“Preferably, the endless Proximity Sleep Mode routine 100 may be interrupted by the controller 30 (pre-emptive scheduling), so that other tasks with higher priority may be executed instead of routine 100. For instance, as soon as the controller 30 has detected that the user has started initiating an outgoing call, the routine 100 is temporarily stopped and the display 6 is activated, thereby avoiding an undesired situation where e.g. the hand or head of the user is accidentally detected by the proximity detector 20, while the telephone number to be called is entered on the keypad 7. Correspondingly, routine 100 may be temporarily aborted upon detection of an incoming telephone call, text message (SMS; Short Messages Services), etc.”). A person of ordinary skill in the art at the time of the alleged invention would understand that since Sparre teaches that the microprocessor only temporarily halts the normal routine, the microprocessor would need to be able “determine whether a telephone call is active” in order to determine the appropriate time to start up the normal routine again. A person of ordinary skill in the art at the time of the alleged invention would have such understanding because they would for example, further understand that once the user of the mobile station is done initiating the outgoing call by dialing keys on the handset they will place the handset next to their head for the duration of the call at which time the proximity detector 20 of Sparre would need to be functioning in order to signal to the microprocessor that the display should be powered down in order for the battery conservation purpose of Sparre to be realized. It would therefore be obvious to one of ordinary skill in the art at the time of the alleged invention that the microprocessor of Sparre be modified to “determine whether a telephone call is active.” Doing so would be within the skill of one of ordinary skill in the art, and would constitute, at

least, combining prior art elements according to known methods to yield predictable results, a simple substitution of one known element for another to obtain predictable results, the use of a known technique to improve similar devices in the same way, the application of a known technique to a known device ready for improvement to yield a predictable result, and obvious to try.

To the extent Sparre is deemed to not expressly or inherently disclose a microprocessor adapted to “determine whether a telephone call is active,” it would be obvious to combine the disclosure of Sparre with those of Fukiharu 598 as described in the Fukiharu 598 claim chart, which is incorporated herein in its entirety by reference. Sparre and Fukiharu 598 are both directed to conserving battery power in mobile stations generally and more particularly at conserving battery power in mobile stations by using sensors to detect when the user of the mobile station is in a call and unlikely to be looking at the display (as when, for example, the proximity sensor detects the user’s ear by the mobile station) and to power off the display of mobile stations at such times. Sparre at 6 (“The purpose of the present invention is to propose an improved solution to the problem of preserving electric power in a portable electric apparatus having a liquid crystal display. In particular, the invention aims at achieving such power preservation at a lower cost and with improved accuracy, as compared to the prior art solutions. According to the invention, the portable electric apparatus is provided with a proximity detector, which is arranged to detect when an external object is very close to a specific portion of the apparatus (for instance less than 3 cm from the display). The external object may be the user’s ear (when the telephone is held in a normal position for conversation), or the interior walls of a pocket or bag, in which the telephone has been placed by the user. In all circumstances, the presence of such an external object indicates that the apparatus is not in a position, where it is useful to keep the display turned on, since the user is physically prevented from visual access to the display. Therefore, when the proximity detector has detected the presence of the external object, the display may be powered off or present less visual information.”); Fukiharu 598 at ¶ 0018 (“The present invention, through the use of a structure as described above, enables a reduction in the consumption of battery power, through enabling the lighting devices to be turned

	<p>OFF when the ear is caused to contact the receiver portion in order to hear the receiver sound during voice communications of a mobile telephone when the lighting devices (backlights) for a liquid crystal display device and keypad portion of a mobile telephone are lit, such as that night.”). A person of ordinary skill in the art at the time of the alleged invention would be motivated to modify Sparre to use “a microprocessor adapted to...determine whether a telephone call is active,” as disclosed in Fukiharu 598 for a number of different reasons, including that it would support Sparre’s ability to conserve battery power in mobile stations, and doing so would be within the knowledge and ability of a person of ordinary skill in the art at the time of the alleged invention. The combination would constitute, at least, combining prior art elements according to known methods to yield predictable results, a simple substitution of one known element for another to obtain predictable results, the use of a known technique to improve similar devices in the same way, the application of a known technique to a known device ready for improvement to yield a predictable result, and obvious to try.</p>
<p>[1e] (b) receive the signal from the proximity sensor; and</p>	<p>Sparre discloses the microprocessor adapted to receive the signal from the proximity sensor.</p> <p>For example: “A portable electric apparatus (1) has a display (6) of the type comprising a liquid crystal layer. The display has an active state for presenting visual information in response to a supply of electric energy to the liquid crystal layer. The display also has an inactive state, in which less electric energy is supplied to the liquid crystal layer and less visual information consequently is presented. The apparatus (1) also has a proximity detector (20) for detecting the presence of an object in proximity with the apparatus and in response causing the display (6) to enter its inactive state.” Sparre at Abstract.</p> <p>“Therefore, when the proximity detector has detected the presence of the external object, the display may be powered off or present less visual information. More specifically, the purpose above has been achieved for a portable electric apparatus</p>

having a display of the type comprising a liquid crystal layer, wherein the display has an active state for presenting visual information in response to a supply of electric energy to the liquid crystal layer, and wherein the display also has an inactive state, in which less electric energy is supplied to the liquid crystal layer and less visual information consequently is presented, by the provision of a proximity detector for detecting the presence of an object in proximity with the apparatus and in response causing the display to enter its inactive state.

The purpose has also been achieved through a method of preserving power for a portable electric apparatus having a display of the type comprising a liquid crystal layer, the display having an active state for presenting visual information in response to a supply of electric energy to the liquid crystal layer, the display also having an inactive state, in which less electric energy is supplied to the liquid crystal layer and less visual information consequently is presented, by the steps of determining whether an object is present in proximity with the apparatus, and, if so, causing the display to enter its inactive state.” Sparre at 6-7.

“A proximity detector is provided at the uppermost portion of the front surface of the telephone 1. In the embodiment shown in FIG 1, the proximity detector 20 is located immediately above the display 6 next to the speaker 4. However, the exact location of the proximity detector 20 is not critical but may be varied between many different positions, as long as the functional requirements specified below are satisfied.

In one embodiment, the proximity detector 20 is an IR (infrared) detector, which is arranged to emit infrared light from the front surface of the telephone 1 and is arranged to detect infrared light, that has been reflected from an external object located close to the upper portion of front surface of the telephone 1. Hence, as is generally known per se, the proximity detector 20 may measure the intensity of the reflected infrared light and in response determine whether any external object is present in proximity with the detector 20. By establishing a predetermined threshold for the fraction of infrared light reflected back to the proximity detector 20, it is possible to define a predetermined range, within which any external object will be detected by the proximity detector 20. Obviously, such a threshold will depend on i.a. the surface

structure and material of the external object in question. However, such an issue is regarded nothing more than a practical parameter, which in an actual application will have to be tested, evaluated and determined by a skilled person. Proximity detectors as such are generally known and are commercially available on the market in large numbers .

According to an alternative embodiment, if the mobile telephone is equipped with an IR interface for wireless data communication with external devices (such as a handheld computer) , the IR transmitter thereof may be used also for the purpose of transmitting IR light to be detected by the proximity detector 20.

Alternatively, the proximity detector 20 may operate by emitting and detecting visible light, by detecting thermal energy generated by the external object, or by detecting the external object by capacitive means.

The main components of the mobile telephone 1 are shown in FIG 2. A controller 30 is operatively connected to the display 6, the keypad 7, the proximity detector 20 and a memory 40. The controller 30 may be any microprocessor, central processing unit (CPU) or other piece of electronic logic circuitry already used in the telephone 1 for performing the various functions thereof (such as telephone call control, keypad control, display control, or execution of utility programs such as a calculator program, electronic game programs, etc) . Alternatively, the controller 30 may be realized by separate electronic logic circuitry, which in itself is generally known, such as a microprocessor, an integrated circuit network, etc. Correspondingly, the memory 40 may be of any type generally known within the field of portable electric apparatuses, such as an EEPROM memory, a RAM memory, a flash memory etc.

Together with the proximity detector 20, the controller 30 is arranged to bring the liquid crystal display 6 into its inactive state, whenever an external object is detected in proximity with the portion of the telephone 1, where the display is located. This functionality is referred to as Proximity Sleep Mode in the following.” Sparre at 9-11.

1/2

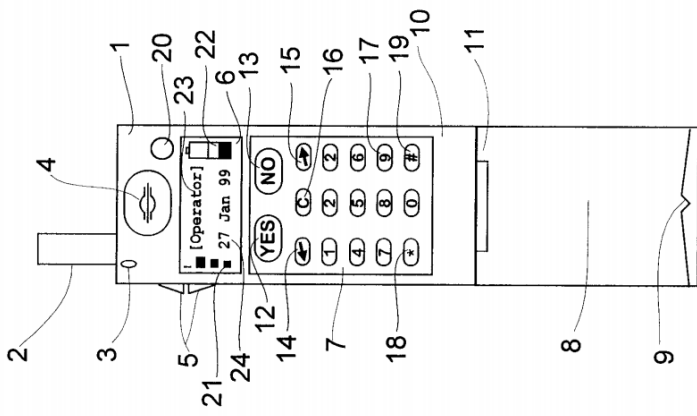

FIG 1

Sparre at Fig. 1.

“The main components of the mobile telephone 1 are shown in FIG 2. A controller 30 is operatively connected to the display 6, the keypad 7, the proximity detector 20 and a memory 40.” Sparre at 10.

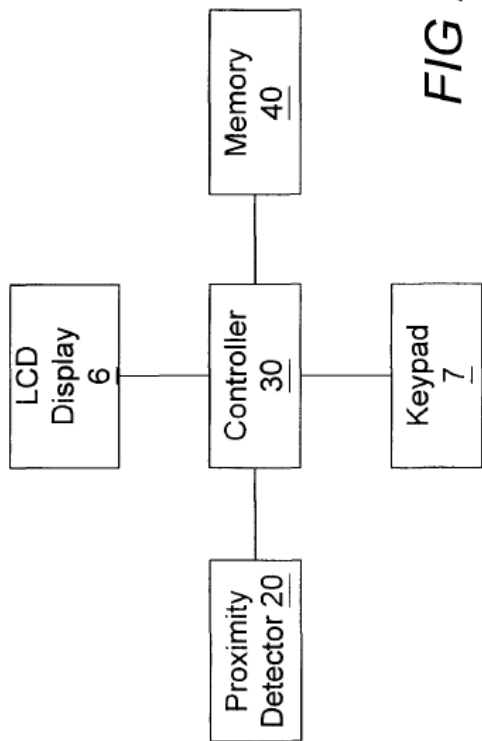

FIG 2

Sparre at Fig. 2.

“FIG 3 illustrates a Proximity Sleep Mode routine 100, which according to one embodiment is regularly executed by the controller 30. After the initial step 100 the controller 30 determines, in step 110, whether the Proximity Sleep Mode feature has been disabled by the user. If the answer is in the affirmative, the control is immediately returned to the beginning of routine 100. If, on the other hand, the Proximity Sleep Mode feature has not been disabled by the user, then the output from the proximity detector 20 is read in step 120. In step 130, the value of the output retrieved in step 120 is examined, so as to determine whether any external object is present in proximity with the proximity detector 20 and, consequently, the mobile telephone 1. Preferably, it is required in steps 120 and 130 that the presence of the external object is continuously detected for a certain period of time, before it is ultimately concluded that the display is indeed blocked by an external object. In this way, rapid hand movements, etc., past the display will not accidentally turn off the display.

If the answer of step 130 is in the affirmative, the controller 30 forces the liquid crystal display 6 to enter its inactive state in a subsequent step 150. As previously mentioned,

the inactive state may either involve displaying only a limited set of icons (such as the remaining battery charge indicator 22), or completely turning off the liquid crystal display 6 by stop supplying electric energy to the liquid crystal layer. The first case is represented by a step 155b in FIG 3, whereas the second case is represented by steps 155a and 157a. Following the last step (i.e., either step 155b or step 157a) the control is transferred back to the beginning of routine 100. If, on the other hand, no external object has been detected in step 130, the controller 30 causes the liquid crystal display 6 to enter its active state, provided that the display 6 is not already active, in a step 140. When step 140 has been completed, the control is transferred back to the beginning of routine 100. In this way, an endless loop is formed by steps 100, 110, 120, 130, 140, 150 and 155b and 157a, respectively. Consequently, the presence of an external object in proximity with the proximity detector 20 will be continuously monitored, and in response to detecting such an external object, the display 6 will be set to its active state, thereby saving electric power. Furthermore, if the external object disappears from the proximity detector 20, the display 6 is again set to its active state in step 140.” Sparre at 11-13.

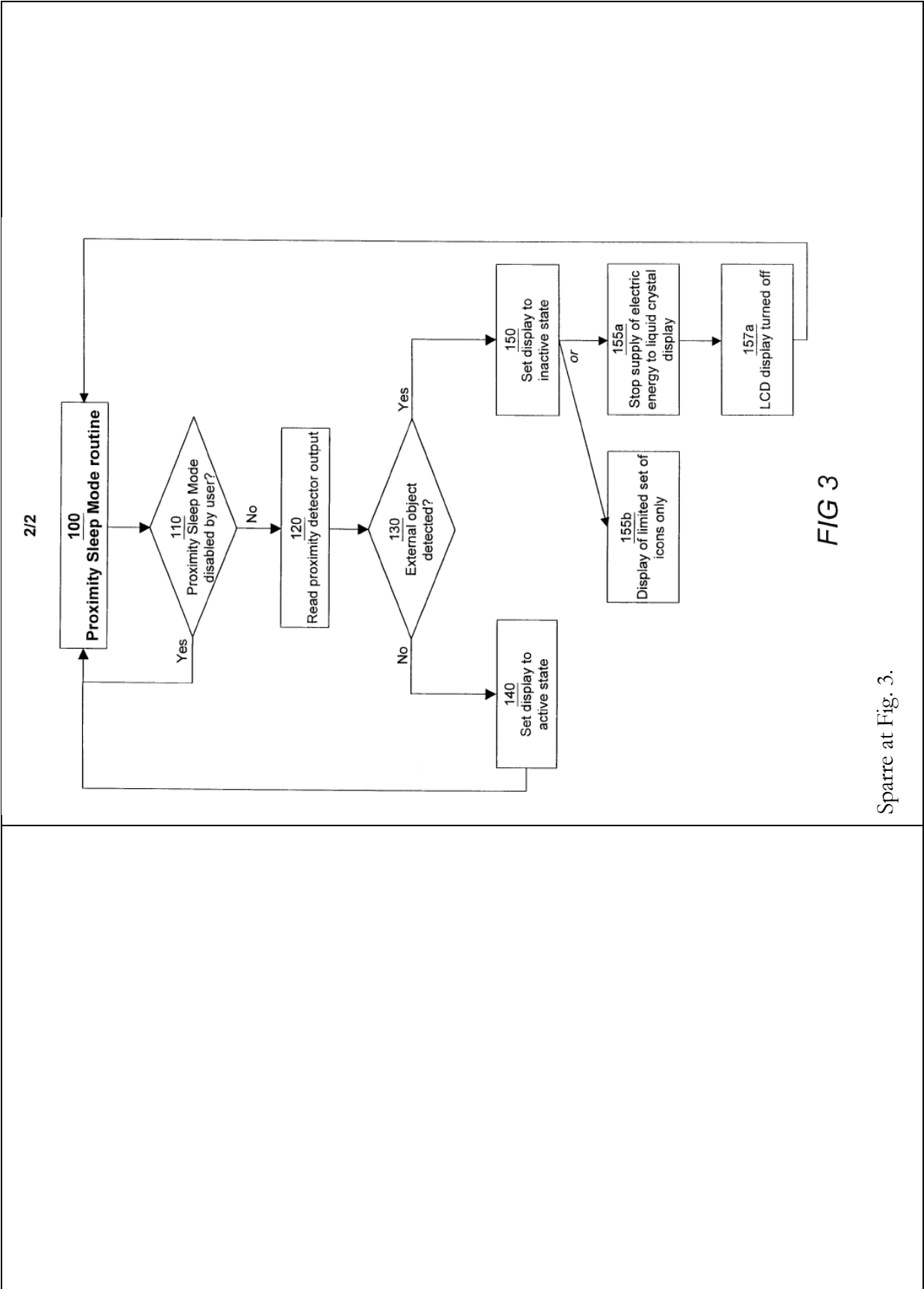

FIG 3

Sparre at Fig. 3.

	<p>“1. A portable electric apparatus (1) having a display (6) of the type comprising a liquid crystal, the display having an active state for presenting visual information in response to a supply of electric energy to the liquid crystal layer, the display also having an inactive state, in which less electric energy is supplied to the liquid crystal layer and less visual information consequently is presented, characterized by a proximity detector (20) for detecting the presence of an object in proximity with the apparatus (1) and in response causing the display (6) to enter its inactive state.” Sparre at claim 1.</p> <p>“11. A method of preserving power for a portable electric apparatus (1) having a display (6) of the type comprising a liquid crystal layer, the display having an active state for presenting visual information in response to a supply of electric energy to the liquid crystal layer, the display also having an inactive state, in which less electric energy is supplied to the liquid crystal layer and less visual information consequently is presented, characterized by the steps of determining whether an object is present in proximity with the apparatus (1) , and, if so, causing the display (6) to enter its inactive state.” Sparre at claim 11.</p>
<p>[1f] (c) reduce power to the display if (i) the microprocessor determines that a telephone call is active and (ii) the signal indicates the proximity of the external object; wherein:</p>	<p>Sparre discloses the microprocessor adapted to reduce power to the display if (i) the microprocessor determines that a telephone call is active and (ii) the signal indicates the proximity of the external object.</p> <p>For example: <i>see</i> discussions of claim elements [1b], [1d], [1e], <i>supra</i>, which are incorporated herein by reference.</p> <p>“A portable electric apparatus (1) has a display (6) of the type comprising a liquid crystal layer. The display has an active state for presenting visual information in response to a supply of electric energy to the liquid crystal layer. The display also has</p>

an inactive state, in which less electric energy is supplied to the liquid crystal layer and less visual information consequently is presented. The apparatus (1) also has a proximity detector (20) for detecting the presence of an object in proximity with the apparatus and in response causing the display (6) to enter its inactive state.” Sparre at Abstract.

“Therefore, when the proximity detector has detected the presence of the external object, the display may be powered off or present less visual information. More specifically, the purpose above has been achieved for a portable electric apparatus having a display of the type comprising a liquid crystal layer, wherein the display has an active state for presenting visual information in response to a supply of electric energy to the liquid crystal layer, and wherein the display also has an inactive state, in which less electric energy is supplied to the liquid crystal layer and less visual information consequently is presented, by the provision of a proximity detector for detecting the presence of an object in proximity with the apparatus and in response causing the display to enter its inactive state.

The purpose has also been achieved through a method of preserving power for a portable electric apparatus having a display of the type comprising a liquid crystal layer, the display having an active state for presenting visual information in response to a supply of electric energy to the liquid crystal layer, the display also having an inactive state, in which less electric energy is supplied to the liquid crystal layer and less visual information consequently is presented, by the steps of determining whether an object is present in proximity with the apparatus, and, if so, causing the display to enter its inactive state.” Sparre at 6-7.

“The main components of the mobile telephone 1 are shown in FIG 2. A controller 30 is operatively connected to the display 6, the keypad 7, the proximity detector 20 and a memory 40. The controller 30 may be any microprocessor, central processing unit (CPU) or other piece of electronic logic circuitry already used in the telephone 1 for performing the various functions thereof (such as telephone call control, keypad

control, display control, or execution of utility programs such as a calculator program, electronic game programs, etc) . Alternatively, the controller 30 may be realized by separate electronic logic circuitry, which in itself is generally known, such as a microprocessor, an integrated circuit network, etc. Correspondingly, the memory 40 may be of any type generally known within the field of portable electric apparatuses, such as an EEPROM memory, a RAM memory, a flash memory etc.

Together with the proximity detector 20, the controller 30 is arranged to bring the liquid crystal display 6 into its inactive state, whenever an external object is detected in proximity with the portion of the telephone 1, where the display is located. This functionality is referred to as Proximity Sleep Mode in the following.” Sparre at 10-11.

1/2

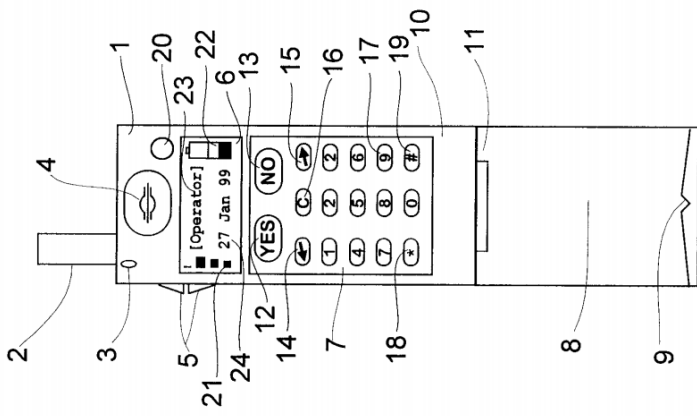

FIG 1

Sparre at Fig. 1.

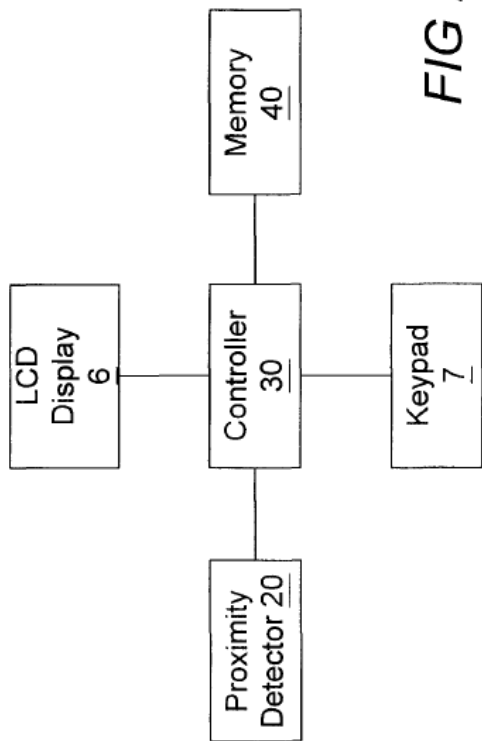

FIG 2

Sparre at Fig. 2.

“Together with the proximity detector 20, the controller 30 is arranged to bring the liquid crystal display 6 into its inactive state, whenever an external object is detected in proximity with the portion of the telephone 1, where the display is located. This functionality is referred to as Proximity Sleep Mode in the following.

According to one embodiment the man-machine interface of the mobile telephone 1 has an option for allowing the user to disable the Proximity Sleep Mode functionality, so that the display 6 is not turned off, even if an external object is detected by the proximity detector 20. The reason why the user should be given an opportunity to disable this feature is to prevent the display from accidentally being turned off, when the mobile telephone is carried in for instance a protective cover bag. Information regarding whether the Proximity Sleep Mode feature has been disabled by the user is preferably stored as a settings parameter in the memory 40.

FIG 3 illustrates a Proximity Sleep Mode routine 100, which according to one embodiment is regularly executed by the controller 30. After the initial step 100 the

<p>controller 30 determines, in step 110, whether the Proximity Sleep Mode feature has been disabled by the user. If the answer is in the affirmative, the control is immediately returned to the beginning of routine 100. If, on the other hand, the Proximity Sleep Mode feature has not been disabled by the user, then the output from the proximity detector 20 is read in step 120. In step 130, the value of the output retrieved in step 120 is examined, so as to determine whether any external object is present in proximity with the proximity detector 20 and, consequently, the mobile telephone 1. Preferably, it is required in steps 120 and 130 that the presence of the external object is continuously detected for a certain period of time, before it is ultimately concluded that the display is indeed blocked by an external object. In this way, rapid hand movements, etc., past the display will not accidentally turn off the display.</p> <p>If the answer of step 130 is in the affirmative, the controller 30 forces the liquid crystal display 6 to enter its inactive state in a subsequent step 150. As previously mentioned, the inactive state may either involve displaying only a limited set of icons (such as the remaining battery charge indicator 22), or completely turning off the liquid crystal display 6 by stop supplying electric energy to the liquid crystal layer. The first case is represented by a step 155b in FIG 3, whereas the second case is represented by steps 155a and 157a. Following the last step (i.e., either step 155b or step 157a) the control is transferred back to the beginning of routine 100. If, on the other hand, no external object has been detected in step 130, the controller 30 causes the liquid crystal display 6 to enter its active state, provided that the display 6 is not already active, in a step 140. When step 140 has been completed, the control is transferred back to the beginning of routine 100. In this way, an endless loop is formed by steps 100, 110, 120, 130, 140, 150 and 155b and 157a, respectively. Consequently, the presence of an external object in proximity with the proximity detector 20 will be continuously monitored, and in response to detecting such an external object, the display 6 will be set to its active state, thereby saving electric power. Furthermore, if the external object disappears from the proximity detector 20, the display 6 is again set to its active state in step 140.</p> <p>Preferably, the endless Proximity Sleep Mode routine 100 may be interrupted by the controller 30 (pre-emptive scheduling), so that other tasks with higher priority may be executed instead of routine 100. For instance, as soon as the controller 30 has detected</p>	
---	--

that the user has started initiating an outgoing call, the routine 100 is temporarily stopped and the display 6 is activated, thereby avoiding an undesired situation where e.g. the hand or head of the user is accidentally detected by the proximity detector 20, while the telephone number to be called is entered on the keypad 7.

Correspondingly, routine 100 may be temporarily aborted upon detection of an incoming telephone call, text message (SMS; Short Messages Services), etc.” Sparre 11-13.

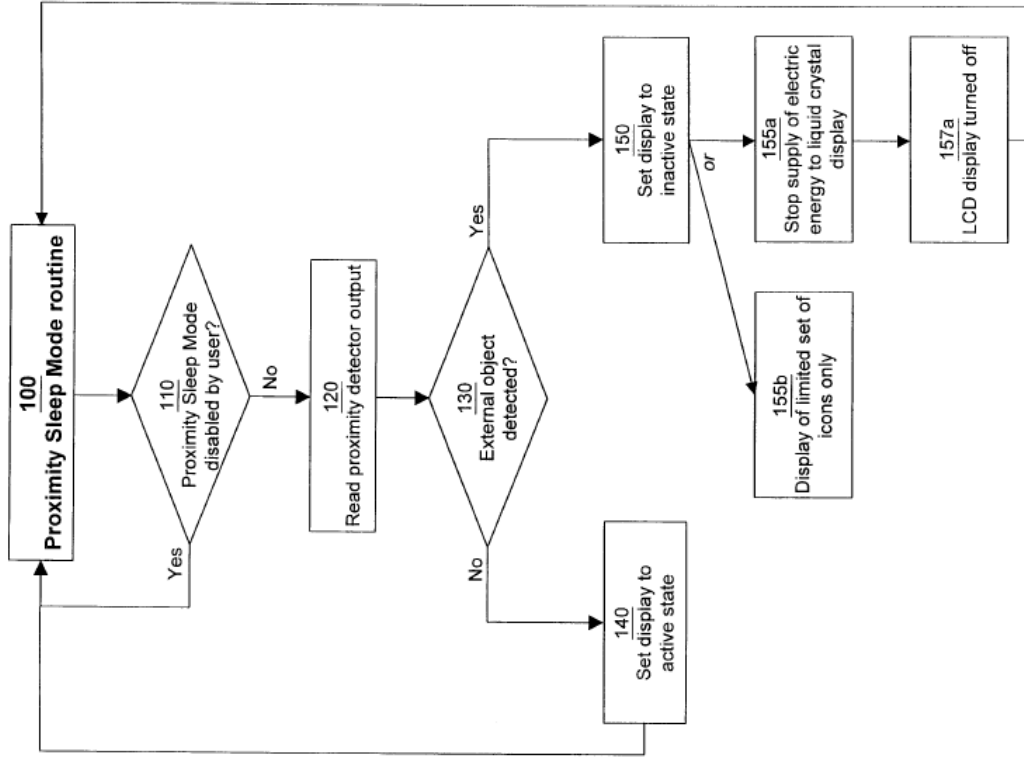

FIG 3

Sparre at Fig. 3.

“1. A portable electric apparatus (1) having a display (6) of the type comprising a liquid crystal, the display having an active state for presenting visual information in response to a supply of electric energy to the liquid crystal layer, the display also having an inactive state, in which less electric energy is supplied to the liquid crystal layer and less visual information consequently is presented, characterized by a proximity detector (20) for detecting the presence of an object in proximity with the apparatus (1) and in response causing the display (6) to enter its inactive state.” Sparre at claim 1.

“8. A portable electric apparatus (1) according to any preceding claim, wherein the display (6) is arranged, in its active state, to present a plurality of graphical symbols or icons and wherein the display (6) , in its inactive state, is arranged to present only some of said plurality of graphical symbols or icons.

9. A portable electric apparatus (1) according to any of claims 1-7, wherein the inactive state of the display

(6) is a state, where the display is electrically turned off.” Sparre at claims 8-9.

“11. A method of preserving power for a portable electric apparatus (1) having a display (6) of the type comprising a liquid crystal layer, the display having an active state for presenting visual information in response to a supply of electric energy to the liquid crystal layer, the display also having an inactive state, in which less electric energy is supplied to the liquid crystal layer and less visual information consequently is presented, characterized by the steps of determining whether an object is present in proximity with the apparatus (1) , and, if so, causing the display (6) to enter its inactive state.” Sparre at claim 11.

“12. A method according to claim 11, comprising an initial step of determining whether a user of the apparatus has chosen to disable the execution of the steps in claim 11, wherein the steps of claim 12 are only executed, if no such choice has been made by the user.” Sparre at claim 12.

To the extent Sparre is deemed to not disclose the microprocessor adapted to “reduce power to the display if (i) the microprocessor determines that a telephone call is active and (ii) the signal indicates the proximity of the external object,” Sparre renders this limitation obvious to one of skill in the art. Sparre “is directed at a new and inventive way of preserving electric power in such a portable electric apparatus by bringing the display to its inactive state whenever appropriate. Sparre at 1. Sparre discloses that “apparatus (1) also has a proximity detector (20) for detecting the presence of an object in proximity with the apparatus and in response causing the display (6) to enter its inactive state.” Sparre at Abstract. Also, as set forth in the discussion of claim element [1d], *supra*, Sparre discloses determining whether a telephone call is active. In order to further Sparre’s stated goal of conserving battery power in a mobile telephone, it would be obvious to a person of skill in the art to modify Sparre’s microprocessor to reduce power to the display if the controller (comprising a microprocessor, *see* Sparre at 10) determines that a telephone call is active, and thus “reduce power to the display if (i) the microprocessor determines that a telephone call is active and (ii) the signal indicates the proximity of the external object.”

To the extent Sparre is deemed to not expressly disclose the microprocessor adapted to “(c) reduce power to the display if (i) the microprocessor determines that a telephone call is active and (ii) the signal indicates the proximity of the external object,” Mantyjärvi inherently discloses this limitation or renders it obvious to a person of ordinary skill in the art at the time of the alleged invention for the reasons described in claim element [1h], *infra*, incorporate herein by reference.

[1g] the telephone call is a wireless telephone call;

Sparre discloses the telephone call as a wireless telephone call.

For example: *see* discussion of claim element 1[d], *supra*, which is incorporated herein by reference.

“The highest power consumption for a liquid crystal display occurs when an event takes place in the telephone, for instance when a telephone call is generated or ended. In those situations, the visibility of the LCD display is amplified by turning on a back-light illumination of the display. Such back-light illumination consumes too much power than what is acceptable in a long-term perspective. Therefore, back-light illumination is normally restricted to a short time period of a few seconds around the respective event, such as the entering of a telephone number on the keypad, the reception of an incoming call or the termination of an ongoing call (on-hook).” Sparre at 3.”

“US-A-5 881 377 discloses a radio telephone with a power-saving arrangement, which is adapted to detect the presence of the radio telephone in proximity with an ear of a user and which also is adapted to turn off a display of the radio telephone. Aforesaid arrangement may be of a type capable of detecting heat, or comprise an opto-electric switch. The display of the radio telephone is of a type comprising light emitting diodes (LED). According to an alternative embodiment of US-A-5 881 377, the display is a liquid crystal display, and a light emitting diode is provided for backlighting the LCD-display. In this embodiment, the backlighting LED, but not the actual liquid crystal display, is switched on and off for saving electric power in response to whether or not the radio telephone is kept near the user's head.” Sparre at 5.”

“An example of a portable electric apparatus is given in FIG 1 in the form of a mobile telephone 1 having a housing 10, an antenna 2 mounted on top of the housing, a status indicator LED 3, a speaker 4, volume adjustment controls 5, an LCD display 6 and a keypad 7. The keypad 7 has a plurality of individual keys, such a YES button 12

and a NO button 13, arrow keys 14, 15, a clear key 16, numeric keys 17 (labeled 0 through 9), a star key 18 and a hash key 19.” Sparre at 8.

1/2

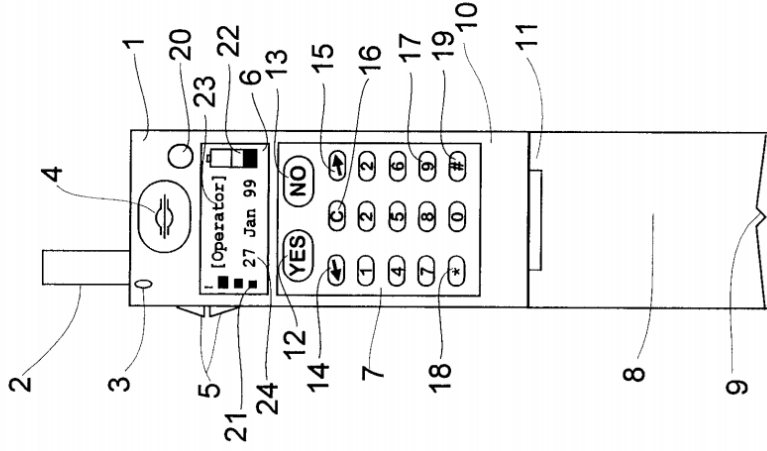

FIG 1

Sparre at Fig. 1.

“Preferably, the endless Proximity Sleep Mode routine 100 may be interrupted by the controller 30 (pre-emptive scheduling), so that other tasks with higher priority may be

executed instead of routine 100. For instance, as soon as the controller 30 has detected that the user has started initiating an outgoing call, the routine 100 is temporarily stopped and the display 6 is activated, thereby avoiding an undesired situation where e.g. the hand or head of the user is accidentally detected by the proximity detector 20, while the telephone number to be called is entered on the keypad 7.

Correspondingly, routine 100 may be temporarily aborted upon detection of an incoming telephone call, text message (SMS; Short Messages Services), etc.” Sparre at 13.

“10. A portable electric apparatus (1) according to any preceding claim, wherein the apparatus is a telecommunication device, preferably a mobile telephone (1).” Sparre at claim 10.

To the extent Sparre is deemed to not expressly disclose that “the telephone call is a wireless telephone call,” Sparre inherently discloses this limitation. In Sparre, the “portable electric apparatus” “is a telecommunication device, preferably a mobile telephone.” Sparre at claim 10. A person of skill in the art would understand that if the portable electric apparatus is a mobile telephone, and the mobile telephone is adapted to determine whether a telephone call is active, the telephone call performed by the portable electronic apparatus is necessarily a wireless telephone call.

To the extent Sparre is deemed to not expressly or inherently disclose that “the telephone call is a wireless telephone call,” Sparre renders this limitation obvious to a person of skill in the art. A person of skill in the art would be motivated to modify the

<p>[1h] the microprocessor reduces power to the display while the signal indicates the proximity of the external object only if the microprocessor determines that the wireless telephone call is active; and</p>	<p>the telephone call described in Sparre such that it is a wireless telephone call because doing so would better utilize the <i>mobile</i> configuration of mobile telephone 1 in Sparre.</p>
<p>Sparre discloses that the microprocessor reduces power to the display while the signal indicates the proximity of the external object only if the microprocessor determines that the wireless telephone call is active.</p> <p>For example: <i>see</i> discussion of claim element [1f], <i>supra</i>, which is incorporated herein by reference.</p> <p>To the extent Sparre is deemed to not expressly disclose that “the microprocessor reduces power to the display while the signal indicates the proximity of the external object only if the microprocessor determines that the wireless telephone call is active,” Sparre inherently discloses this limitation. As explained above for element [1d], and incorporated herein by reference, Sparre explicitly or inherently discloses, or renders obvious a microprocessor adapted to “determine whether a telephone call is active.” Sparre further discloses that instead of constantly monitoring the proximity sensor, the microprocessor of Sparre could be configured to monitor the proximity sensor in other “known power preservation arrangements.” <i>See</i> Sparre at 13 (“As an alternative to the endless loop formed by routine 100 in FIG 3, the Proximity Sleep Mode routine may be executed by the controller 30 according to a predetermined time schedule, for instance once every second, without returning to the beginning of routine 100 upon termination of the last step 140, 155b or 157a, respectively. The invention has been described above with reference to a few embodiments. However, the present invention shall in no way be limited by the description above; the scope of the invention is best defined by the appended independent claims. Other embodiments than the particular ones described above are equally possible within the scope of the invention. The invention may also be combined with known power preservation arrangements, such as automatically turning off the display backlighting after certain time, as described in previous sections.”). A person of ordinary skill in the art at the time of the alleged invention would understand that a known power preservation arrangement that would necessarily be employed to further Sparre’s goal of battery conservation would be to only monitor Sparre’s proximity sensor when Sparre’s</p>	<p>Sparre discloses that the microprocessor reduces power to the display while the signal indicates the proximity of the external object only if the microprocessor determines that the wireless telephone call is active.</p> <p>For example: <i>see</i> discussion of claim element [1f], <i>supra</i>, which is incorporated herein by reference.</p> <p>To the extent Sparre is deemed to not expressly disclose that “the microprocessor reduces power to the display while the signal indicates the proximity of the external object only if the microprocessor determines that the wireless telephone call is active,” Sparre inherently discloses this limitation. As explained above for element [1d], and incorporated herein by reference, Sparre explicitly or inherently discloses, or renders obvious a microprocessor adapted to “determine whether a telephone call is active.” Sparre further discloses that instead of constantly monitoring the proximity sensor, the microprocessor of Sparre could be configured to monitor the proximity sensor in other “known power preservation arrangements.” <i>See</i> Sparre at 13 (“As an alternative to the endless loop formed by routine 100 in FIG 3, the Proximity Sleep Mode routine may be executed by the controller 30 according to a predetermined time schedule, for instance once every second, without returning to the beginning of routine 100 upon termination of the last step 140, 155b or 157a, respectively. The invention has been described above with reference to a few embodiments. However, the present invention shall in no way be limited by the description above; the scope of the invention is best defined by the appended independent claims. Other embodiments than the particular ones described above are equally possible within the scope of the invention. The invention may also be combined with known power preservation arrangements, such as automatically turning off the display backlighting after certain time, as described in previous sections.”). A person of ordinary skill in the art at the time of the alleged invention would understand that a known power preservation arrangement that would necessarily be employed to further Sparre’s goal of battery conservation would be to only monitor Sparre’s proximity sensor when Sparre’s</p>

microprocessor determines that a call is active. This would further preserve battery power that would otherwise be spent needlessly monitoring the proximity sensor. Therefore a person of ordinary skill in the art at the time of the alleged invention would understand that Sparre necessarily discloses that “the microprocessor reduces power to the display while the signal indicates the proximity of the external object only if the microprocessor determines that the wireless telephone call is active.”

To the extent Sparre is deemed to not expressly or inherently disclose that “the microprocessor reduces power to the display while the signal indicates the proximity of the external object only if the microprocessor determines that the wireless telephone call is active,” Sparre renders this limitation obvious to one of skill in the art. For example, as explained above for element [1d], and incorporated herein by reference, Sparre explicitly or inherently discloses, or renders obvious a microprocessor adapted to “determine whether a telephone call is active.” Sparre further discloses that instead of constantly monitoring the proximity sensor, the microprocessor of Sparre could be configured to monitor the proximity sensor in other “known power preservation arrangements.” *See* Sparre at 13 (“As an alternative to the endless loop formed by routine 100 in FIG 3, the Proximity Sleep Mode routine may be executed by the controller 30 according to a predetermined time schedule, for instance once every second, without returning to the beginning of routine 100 upon termination of the last step 140, 155b or 157a, respectively. The invention has been described above with reference to a few embodiments. However, the present invention shall in no way be limited by the description above; the scope of the invention is best defined by the appended independent claims. Other embodiments than the particular ones described above are equally possible within the scope of the invention. The invention may also be combined with known power preservation arrangements, such as automatically turning off the display backlighting after certain time, as described in previous sections.”). A person of ordinary skill in the art at the time of the alleged invention would understand that a known power preservation arrangement that could be employed to further Sparre’s goal of battery conservation would be to only monitor Sparre’s proximity sensor when Sparre’s microprocessor determines that a call is active. This would further preserve battery power that would

otherwise be spent needlessly monitoring the proximity sensor. It would therefore be obvious to one of ordinary skill in the art at the time of the alleged invention that the microprocessor of Sparre be modified such that “the microprocessor reduces power to the display while the signal indicates the proximity of the external object only if the microprocessor determines that the wireless telephone call is active.” Doing so would be within the skill of one of ordinary skill in the art, and would constitute, at least, combining prior art elements according to known methods to yield predictable results, a simple substitution of one known element for another to obtain predictable results, the use of a known technique to improve similar devices in the same way, the application of a known technique to a known device ready for improvement to yield a predictable result, and obvious to try.

To the extent Sparre is deemed to not expressly or inherently disclose that “the microprocessor reduces power to the display while the signal indicates the proximity of the external object only if the microprocessor determines that the wireless telephone call is active,” it would be obvious to combine the disclosure of Sparre with those of Fukiharu 598 as described in the Fukiharu 598 claim chart, which is incorporated herein in its entirety by reference. Sparre and Fukiharu 598 are both directed to conserving battery power in mobile stations generally and more particularly at conserving battery power in mobile stations by using sensors to detect when the user of the mobile station is in a call and unlikely to be looking at the display (as when, for example, the proximity sensor detects the user’s ear by the mobile station) and to power off the display of mobile stations at such times. Sparre at 6 (“The purpose of the present invention is to propose an improved solution to the problem of preserving electric power in a portable electric apparatus having a liquid crystal display. In particular, the invention aims at achieving such power preservation at a lower cost and with improved accuracy, as compared to the prior art solutions. According to the invention, the portable electric apparatus is provided with a proximity detector, which is arranged to detect when an external object is very close to a specific portion of the apparatus (for instance less than 3 cm from the display). The external object may be the user’s ear (when the telephone is held in a normal position for conversation), or the interior walls of a pocket or bag, in which the telephone has been placed by the

<p>user. In all circumstances, the presence of such an external object indicates that the apparatus is not in a position, where it is useful to keep the display turned on, since the user is physically prevented from visual access to the display. Therefore, when the proximity detector has detected the presence of the external object, the display may be powered off or present less visual information.); Fukiharu 598 at ¶ 0018 (“The present invention, through the use of a structure as described above, enables a reduction in the consumption of battery power, through enabling the lighting devices to be turned OFF when the ear is caused to contact the receiver portion in order to hear the receiver sound during voice communications of a mobile telephone when the lighting devices (backlights) for a liquid crystal display device and keypad portion of a mobile telephone are lit, such as that night.”). A person of ordinary skill in the art at the time of the alleged invention would be motivated to modify Sparre such that “the microprocessor reduces power to the display while the signal indicates the proximity of the external object only if the microprocessor determines that the wireless telephone call is active,” as disclosed in Fukiharu 598 for a number of different reasons, including that it would support Sparre’s ability to conserve battery power in mobile stations, and doing so would be within the knowledge and ability of a person of ordinary skill in the art at the time of the alleged invention. Furthermore, as noted above, Sparre invites combinations with “known power preservation arrangements” such as the one in Fukiharu 598. The combination would constitute, at least, combining prior art elements according to known methods to yield predictable results, a simple substitution of one known element for another to obtain predictable results, the use of a known technique to improve similar devices in the same way, the application of a known technique to a known device ready for improvement to yield a predictable result, and obvious to try.</p>	<p>Sparre discloses the proximity sensor beginning to detect whether an external object is proximate substantially concurrently with the mobile station initiating an outgoing wireless telephone call or receiving an incoming wireless telephone call.</p>
<p>[11] the proximity sensor begins detecting whether an external object is proximate substantially concurrently with the mobile station initiating an outgoing wireless telephone call or receiving an incoming wireless telephone call.</p>	

For example: *see* discussion of claim element [1f], *supra*, which is incorporated herein by reference.

To the extent Sparre is deemed to not expressly disclose that “the proximity sensor begins detecting an external object is proximate substantially concurrently with the mobile station initiating an outgoing wireless telephone call or receiving an incoming wireless telephone call,” Sparre inherently discloses this limitation. As explained above for element [1d], and incorporated herein by reference, Sparre explicitly or inherently discloses, or renders obvious a microprocessor adapted to “determine whether a telephone call is active.” Sparre further discloses that instead of constantly monitoring the proximity sensor, the microprocessor of Sparre could be configured to monitor the proximity sensor in other “known power preservation arrangements.” *See* Sparre at 13 (“As an alternative to the endless loop formed by routine 100 in FIG 3, the Proximity Sleep Mode routine may be executed by the controller 30 according to a predetermined time schedule, for instance once every second, without returning to the beginning of routine 100 upon termination of the last step 140, 155b or 157a, respectively. The invention has been described above with reference to a few embodiments. However, the present invention shall in no way be limited by the description above; the scope of the invention is best defined by the appended independent claims. Other embodiments than the particular ones described above are equally possible within the scope of the invention. The invention may also be combined with known power preservation arrangements, such as automatically turning off the display backlighting after certain time, as described in previous sections.”). A person of ordinary skill in the art at the time of the alleged invention would understand that a known power preservation arrangement that would necessarily be employed to further Sparre’s goal of battery conservation would be for Sparre’s proximity sensor to be detecting as soon as Sparre’s mobile station has initiated an outgoing wireless telephone call or received an incoming wireless telephone call. This would further Sparre’s goal of preserving battery power by (1) preserving power that would otherwise be spent needlessly powering the proximity sensor when there is no need to monitor it (e.g. before a mobile station has initiated an outgoing wireless telephone call or received an incoming wireless telephone call),

and (2) preserving power by ensuring that the display is not needlessly kept powered on (by enabling the proximity sensor to detect, as soon as call has started, that the display cannot be seen and should be powered off). Therefore a person of ordinary skill in the art at the time of the alleged invention would understand that Sparre necessarily discloses that “the proximity sensor begins detecting whether an external object is proximate substantially concurrently with the mobile station initiating an outgoing wireless telephone call or receiving an incoming wireless telephone call.”

To the extent Sparre is deemed to not expressly or inherently disclose that “the proximity sensor begins detecting whether an external object is proximate substantially concurrently with the mobile station initiating an outgoing wireless telephone call or receiving an incoming wireless telephone call,” Sparre renders this limitation obvious to one of skill in the art. For example, as explained above for element [1d], and incorporated herein by reference, Sparre explicitly or inherently discloses, or renders obvious a microprocessor adapted to “determine whether a telephone call is active.” Sparre further discloses that instead of constantly monitoring the proximity sensor, the microprocessor of Sparre could be configured to monitor the proximity sensor in other “known power preservation arrangements.” *See* Sparre at 13 (“As an alternative to the endless loop formed by routine 100 in FIG 3, the Proximity Sleep Mode routine may be executed by the controller 30 according to a predetermined time schedule, for instance once every second, without returning to the beginning of routine 100 upon termination of the last step 140, 155b or 157a, respectively. The invention has been described above with reference to a few embodiments. However, the present invention shall in no way be limited by the description above; the scope of the invention is best defined by the appended independent claims. Other embodiments than the particular ones described above are equally possible within the scope of the invention. The invention may also be combined with known power preservation arrangements, such as automatically turning off the display backlighting after certain time, as described in previous sections.”). A person of ordinary skill in the art at the time of the alleged invention would understand that a known power preservation arrangement that could be employed to further Sparre’s goal of battery conservation would be to only monitor Sparre’s proximity sensor to being detecting as soon as

Sparre's mobile station has initiated an outgoing wireless telephone call or received an incoming wireless telephone call. This would further Sparre's goal of preserving battery power by (1) preserving power that would otherwise be spent needlessly powering the proximity sensor when there is no need to monitor it (e.g. before a mobile station has initiated an outgoing wireless telephone call or received an incoming wireless telephone call), and (2) preserving power by ensuring that the display is not needlessly kept powered on (by enabling the proximity sensor to detect, as soon as call has started, that the display cannot be seen and should be powered off). It would therefore be obvious to one of ordinary skill in the art at the time of the alleged invention that the microprocessor of Sparre be modified such that "the proximity sensor begins detecting whether an external object is proximate substantially concurrently with the mobile station initiating an outgoing wireless telephone call or receiving an incoming wireless telephone call." Doing so would be within the skill of one of ordinary skill in the art, and would constitute, at least, combining prior art elements according to known methods to yield predictable results, a simple substitution of one known element for another to obtain predictable results, the use of a known technique to improve similar devices in the same way, the application of a known technique to a known device ready for improvement to yield a predictable result, and obvious to try.

To the extent Sparre is deemed to not expressly or inherently disclose that "the proximity sensor begins detecting whether an external object is proximate substantially concurrently with the mobile station initiating an outgoing wireless telephone call or receiving an incoming wireless telephone call," it would be obvious to combine the disclosure of Sparre with those of Fukiharu 598 as described in the Fukiharu 598 claim chart, which is incorporated herein in its entirety by reference. Sparre and Fukiharu 598 are both directed to conserving battery power in mobile stations generally and more particularly at conserving battery power in mobile stations by using sensors to detect when the user of the mobile station is in a call and unlikely to be looking at the display (as when, for example, the proximity sensor detects the user's ear by the mobile station) and to power off the display of mobile stations at such times. Sparre at 6 ("The purpose of the present invention is to propose an improved solution to the

problem of preserving electric power in a portable electric apparatus having a liquid crystal display. In particular, the invention aims at achieving such power preservation at a lower cost and with improved accuracy, as compared to the prior art solutions. According to the invention, the portable electric apparatus is provided with a proximity detector, which is arranged to detect when an external object is very close to a specific portion of the apparatus (for instance less than 3 cm from the display). The external object may be the user's ear (when the telephone is held in a normal position for conversation), or the interior walls of a pocket or bag, in which the telephone has been placed by the user. In all circumstances, the presence of such an external object indicates that the apparatus is not in a position, where it is useful to keep the display turned on, since the user is physically prevented from visual access to the display. Therefore, when the proximity detector has detected the presence of the external object, the display may be powered off or present less visual information.); Fukiharu 598 at ¶ 0018 (“The present invention, through the use of a structure as described above, enables a reduction in the consumption of battery power, through enabling the lighting devices to be turned OFF when the ear is caused to contact the receiver portion in order to hear the receiver sound during voice communications of a mobile telephone when the lighting devices (backlights) for a liquid crystal display device and keypad portion of a mobile telephone are lit, such as that night.”). A person of ordinary skill in the art at the time of the alleged invention would be motivated to modify Sparre such that “the proximity sensor begins detecting whether an external object is proximate substantially concurrently with the mobile station initiating an outgoing wireless telephone call or receiving an incoming wireless telephone call,” as disclosed in Fukihara 598 for a number of different reasons, including that it would support Sparre’s ability to conserve battery power in mobile stations, and doing so would be within the knowledge and ability of a person of ordinary skill in the art at the time of the alleged invention. Furthermore, as noted above, Sparre invites combinations with “known power preservation arrangements” such as the one in Fukihara 598. The combination would constitute, at least, combining prior art elements according to known methods to yield predictable results, a simple substitution of one known element for another to obtain predictable results, the use of a known technique to improve similar devices in the same way, the application of a

	<p>known technique to a known device ready for improvement to yield a predictable result, and obvious to try.</p>
<p>[Claim 2] The mobile station of claim 1, wherein the microprocessor reduces power to the display only if (i) the microprocessor determines that a telephone call is active and (ii) the signal indicates the proximity of the external object.</p>	<p>Sparre discloses the microprocessor reducing power to the display only if (i) the microprocessor determines that a telephone call is active and (ii) the signal indicates the proximity of the external object.</p> <p>For example: <i>see</i> discussion of claim element [1f], <i>supra</i>, which is incorporated herein by reference.</p> <p>To the extent Sparre is deemed to not disclose that “the microprocessor reducing power to the display only if (i) the microprocessor determines that a telephone call is active and (ii) the signal indicates the proximity of the external object,” Sparre renders this limitation obvious to one of skill in the art. Sparre “is directed at a new and inventive way of preserving electric power in such a portable electric apparatus by bringing the display to its inactive state whenever appropriate. Sparre at 1. Sparre discloses that “apparatus (1) also has a proximity detector (20) for detecting the presence of an object in proximity with the apparatus and in response causing the display (6) to enter its inactive state.” Sparre at Abstract. Also, as set forth in the discussion of claim element [1d], <i>supra</i>, Sparre discloses determining whether a telephone call is active. In order to further Sparre’s stated goal of conserving battery power in a mobile telephone, it would be obvious to a person of skill in the art to modify Sparre’s microprocessor reduce power to the display only if (i) the microprocessor determines that a telephone call is active and (ii) the signal indicates the proximity of the external object.</p> <p>To the extent Sparre is deemed to not expressly or inherently disclose that “the microprocessor reduces power to the display only if (i) the microprocessor determines that a telephone call is active and (ii) the signal indicates the proximity of the external object,” it would be obvious to combine the disclosure of Sparre with those of Seo as described in the Seo claim chart, which is incorporated herein in its entirety by</p>

	reference, to disclose this claim element. <i>See</i> discussion of claim element [1f], <i>supra</i> , which is incorporated herein by reference.
[Claim 4] The mobile station as recited in claim 1, wherein the microprocessor reduces power to the display by turning off the display.	<p>Sparre discloses the microprocessor reducing power to the display by turning off the display.</p> <p>For example: ‘By supplying electric energy from the display driver through the control lines to the liquid crystal layer, individual elements (crystals or molecules) of the liquid crystal layer may be set to either an on-state, representing an active (e.g. black) pixel in the image presented by the liquid crystal display, or an off-state, representing a blank (e.g. transparent) pixel.</p> <p>In more detail, for a passive-type liquid crystal display, the crystals or molecules of the liquid crystal layer are oriented in parallel with the glass plates in their off-state. Due to the provision of the polarizers, such off-state crystals or molecules will not be visible to a viewer. To make specific crystals or molecules visible (i.e., force them to their on-state), the display driver scans (addresses) the control line matrix and supplies electric energy in the form of a voltage pulse on one specific horizontal control line and one specific vertical control line for each pixel to be set on. At the position where these two specific control lines cross each other, an electric field will be generated and change the orientation of the corresponding crystal or molecule from parallel to orthogonal with respect to the glass plates.’ Sparre at 2-3.</p> <p>“The document RD-A-332 083, which is available from Derwent Info Ltd under access number 92-022097/199203 in the database commonly known as WPI (World Patent Index) , relates to a portable electric apparatus in the form of a remote control unit. This document observes that the functionality of the remote control unit is only required, when the user focuses attention on it . The remote control unit is provided with a motion or acceleration sensor to detect when the remote control unit is carried in the hand of a user. In the absence of such detection, the remote control unit may determine that the unit is placed on a stable surface and is no longer held by the user,</p>

wherein the power-consuming components of the remote control unit may be switched off in order to preserve electric power of the battery. For instance, the display of the remote control unit consumes a substantial amount of electric power from the battery, and by switching off the display in situations other than when the unit is carried by the user, considerable power may be preserved.” Sparré at 4.

“US-A-5 881 377 discloses a radio telephone with a power-saving arrangement, which is adapted to detect the presence of the radio telephone in proximity with an ear of a user and which also is adapted to turn off a display of the radio telephone. Aforesaid arrangement may be of a type capable of detecting heat, or comprise an opto-electric switch. The display of the radio telephone is of a type comprising light emitting diodes (LED). According to an alternative embodiment of US-A-5 881 377, the display is a liquid crystal display, and a light emitting diode is provided for backlighting the LCD-display. In this embodiment, the backlighting LED, but not the actual liquid crystal display, is switched on and off for saving electric power in response to whether or not the radio telephone is kept near the user's head.

US-A-5 729 604 discloses a wireless telephone handset with an arrangement for detecting that the telephone handset is kept in proximity with an ear of a user. This arrangement may for instance operate by detecting infrared radiation and in response turning off a backlighting of a liquid crystal display.

Consequently, from the two US publications referred to above it is known to provide a radio telephone or a wireless telephone handset with a proximity detector, the purpose of which is to detect when the telephone is kept in proximity with the user. The main embodiment of US-A-5 881 377 teaches that the output from the proximity detector may be used for turning off an LED display. The alternative embodiment of this US-publication, as well as the disclosure in US-A-5 729 604, teaches that the backlighting of a liquid crystal display (LCD) can be switched on and off depending on the output from the proximity detector. The purpose of these inventions is to save electric power when the telephone is kept close to the user (i.e. in proximity with the user's ear in talking position). The liquid crystal display is by far the most commonly used type of display in mobile telephones and other types of portable electric apparatus. Both US publications mention liquid crystal displays, but neither of them

teaches or even suggests to use the output from the proximity detector to turn off the actual LCD display. Thus, the US publications only teach to turn off the backlighting of the display.” Sparre at 5-6.

“According to the invention, the portable electric apparatus is provided with a proximity detector, which is arranged to detect when an external object is very close to a specific portion of the apparatus (for instance less than 3 cm from the display) . The external object may be the user's ear (when the telephone is held in a normal position for conversation) , or the interior walls of a pocket or bag, in which the telephone has been placed by the user. In all circumstances, the presence of such an external object indicates that the apparatus is not in a position, where it is useful to keep the display turned on, since the user is physically prevented from visual access to the display. Therefore, when the proximity detector has detected the presence of the external object, the display may be powered off or present less visual information. More specifically, the purpose above has been achieved for a portable electric apparatus having a display of the type comprising a liquid crystal layer, wherein the display has an active state for presenting visual information in response to a supply of electric energy to the liquid crystal layer, and wherein the display also has an inactive state, in which less electric energy is supplied to the liquid crystal layer and less visual information consequently is presented, by the provision of a proximity detector for detecting the presence of an object in proximity with the apparatus and in response causing the display to enter its inactive state.” Sparre at 6-7.

“The liquid crystal display 6 also has an inactive state, where less or even no electric energy is supplied to the liquid crystal layer and, thus, less visual information is presented on the display. In contrast to the active state, during which all graphical information (e.g. the icons 21-24) is presented on the display, only parts of this graphical information is shown on the display during its inactive state. For instance, with reference to FIG 1, only the remaining battery charge indicator 22 (but not the icons 21, 22 or 24) is presented on the display 6 during its inactive state. Such an inactive state essentially corresponds to the "limited icon mode", which was described in the Prior Art section of this document. Alternatively, the liquid crystal display 6 may be completely turned off in its inactive state (i.e., no electric energy is supplied to the

	<p>liquid crystal layer, wherein the power consumption of the display is essentially zero).” Sparre at 9.</p> <p>“If the answer of step 130 is in the affirmative, the controller 30 forces the liquid crystal display 6 to enter its inactive state in a subsequent step 150. As previously mentioned, the inactive state may either involve displaying only a limited set of icons (such as the remaining battery charge indicator 22), or completely turning off the liquid crystal display 6 by stop supplying electric energy to the liquid crystal layer. The first case is represented by a step 155b in FIG 3, whereas the second case is represented by steps 155a and 157a.” Sparre at 12.</p> <p>“The invention may also be combined with known power preservation arrangements, such as automatically turning off the display backlighting after certain time, as described in previous sections.” Sparre at 13.</p> <p>“9. A portable electric apparatus (1) according to any of claims 1-7, wherein the inactive state of the display</p> <p>(6) is a state, where the display is electrically turned off.” Sparre at Claim 9.</p> <p>See discussion of claim element [1f], <i>supra</i>, which is incorporated herein by reference.</p>
<p>[Claim 5] The mobile station as recited in claim 1, wherein the proximity sensor is a mechanical proximity sensor, an optical sensor, or a range-detecting sensor.</p>	<p>Sparre discloses that the proximity sensor is a mechanical proximity sensor, an optical sensor, or a range-detecting sensor.</p> <p>For example: <i>see</i> discussion of claim element [1b], <i>supra</i>, which is incorporated herein by reference.</p> <p>“The document RD-A-332 083, which is available from Derwent Info Ltd under access number 92-022097/199203 in the database commonly known as WPI (World Patent Index) , relates to a portable electric apparatus in the form of a remote control unit. This document observes that the functionality of the remote control unit is only required, when the user focuses attention on it . The remote control unit is provided</p>

with a motion or acceleration sensor to detect when the remote control unit is carried in the hand of a user. In the absence of such detection, the remote control unit may determine that the unit is placed on a stable surface and is no longer held by the user, wherein the power-consuming components of the remote control unit may be switched off in order to preserve electric power of the battery. For instance, the display of the remote control unit consumes a substantial amount of electric power from the battery, and by switching off the display in situations other than when the unit is carried by the user, considerable power may be preserved.” Sparre at 4.

“US-A-5 881 377 discloses a radio telephone with a power-saving arrangement, which is adapted to detect the presence of the radio telephone in proximity with an ear of a user and which also is adapted to turn off a display of the radio telephone. Aforesaid arrangement may be of a type capable of detecting heat, or comprise an opto-electric switch. The display of the radio telephone is of a type comprising light emitting diodes (LED) . According to an alternative embodiment of US-A-5 881 377, the display is a liquid crystal display, and a light emitting diode is provided for backlighting the LCD-display. In this embodiment, the backlighting LED, but not the actual liquid crystal display, is switched on and off for saving electric power in response to whether or not the radio telephone is kept near the user’s head.” Sparre at 5.

“US-A-5 729 604 discloses a wireless telephone handset with an arrangement for detecting that the telephone handset is kept in proximity with an ear of a user. This arrangement may for instance operate by detecting infrared radiation and in response turning off a backlighting of a liquid crystal display” Sparre at 5.

“Consequently, from the two US publications referred to above it is known to provide a radio telephone or a wireless telephone handset with a proximity detector, the purpose of which is to detect when the telephone is kept in proximity with the user. The main embodiment of US-A-5 881 377 teaches that the output from the proximity detector may be used for turning off an LED display. The alternative embodiment of this US-publication, as well as the disclosure in US-A-5 729 604, teaches that the backlighting of a liquid crystal display (LCD) can be switched on and off depending on the output from the proximity detector. The purpose of these inventions is to save electric power when the telephone is kept close to the user (i.e. in proximity with the

user's ear in talking position). The liquid crystal display is by far the most commonly used type of display in mobile telephones and other types of portable electric apparatus. Both US publications mention liquid crystal displays, but neither of them teaches or even suggests to use the output from the proximity detector to turn off the actual LCD display. Thus, the US publications only teach to turn off the backlighting of the display." Sparre at 5-6.

"According to the invention, the portable electric apparatus is provided with a proximity detector, which is arranged to detect when an external object is very close to a specific portion of the apparatus (for instance less than 3 cm from the display) . The external object may be the user's ear (when the telephone is held in a normal position for conversation) , or the interior walls of a pocket or bag, in which the telephone has been placed by the user. In all circumstances, the presence of such an external object indicates that the apparatus is not in a position, where it is useful to keep the display turned on, since the user is physically prevented from visual access to the display. Therefore, when the proximity detector has detected the presence of the external object, the display may be powered off or present less visual information. More specifically, the purpose above has been achieved for a portable electric apparatus having a display of the type comprising a liquid crystal layer, wherein the display has an active state for presenting visual information in response to a supply of electric energy to the liquid crystal layer, and wherein the display also has an inactive state, in which less electric energy is supplied to the liquid crystal layer and less visual information consequently is presented, by the provision of a proximity detector for detecting the presence of an object in proximity with the apparatus and in response causing the display to enter its inactive state." Sparre at 6-7.

"The liquid crystal display 6 also has an inactive state, where less or even no electric energy is supplied to the liquid crystal layer and, thus, less visual information is presented on the display. In contrast to the active state, during which all graphical information (e.g. the icons 21-24) is presented on the display, only parts of this graphical information is shown on the display during its inactive state. For instance, with reference to FIG 1, only the remaining battery charge indicator 22 (but not the icons 21, 22 or 24) is presented on the display 6 during its inactive state. Such an inactive state essentially corresponds to the "limited icon mode", which was described

in the Prior Art section of this document. Alternatively, the liquid crystal display 6 may be completely turned off in its inactive state (i.e., no electric energy is supplied to the liquid crystal layer, wherein the power consumption of the display is essentially zero).” Sparre at 9.

“In one embodiment, the proximity detector 20 is an IR (infrared) detector, which is arranged to emit infrared light from the front surface of the telephone 1 and is arranged to detect infrared light, that has been reflected from an external object located close to the upper portion of front surface of the telephone 1. Hence, as is generally known per se, the proximity detector 20 may measure the intensity of the reflected infrared light and in response determine whether any external object is present in proximity with the detector 20. By establishing a predetermined threshold for the fraction of infrared light reflected back to the proximity detector 20, it is possible to define a predetermined range, within which any external object will be detected by the proximity detector 20. Obviously, such a threshold will depend on i.a. the surface structure and material of the external object in question. However, such an issue is regarded nothing more than a practical parameter, which in an actual application will have to be tested, evaluated and determined by a skilled person. Proximity detectors as such are generally known and are commercially available on the market in large numbers .

According to an alternative embodiment, if the mobile telephone is equipped with an IR interface for wireless data communication with external devices (such as a handheld computer) , the IR transmitter thereof may be used also for the purpose of transmitting IR light to be detected by the proximity detector 20.

Alternatively, the proximity detector 20 may operate by emitting and detecting visible light, by detecting thermal energy generated by the external object, or by detecting the external object by capacitive means.” Sparre at 9-10.

“If the answer of step 130 is in the affirmative, the controller 30 forces the liquid crystal display 6 to enter its inactive state in a subsequent step 150. As previously mentioned, the inactive state may either involve displaying only a limited set of icons (such as the remaining battery charge indicator 22), or completely turning off the liquid crystal display 6 by stop supplying electric energy to the liquid crystal layer. The

first case is represented by a step 155b in FIG 3, whereas the second case is represented by steps 155a and 157a. Following the last step (i.e., either step 155b or step 157a) the control is transferred back to the beginning of routine 100. If, on the other hand, no external object has been detected in step 130, the controller 30 causes the liquid crystal display 6 to enter its active state, provided that the display 6 is not already active, in a step 140. When step 140 has been completed, the control is transferred back to the beginning of routine 100. In this way, an endless loop is formed by steps 100, 110, 120, 130, 140, 150 and 155b and 155a, 157a, respectively. Consequently, the presence of an external object in proximity with the proximity detector 20 will be continuously monitored, and in response to detecting such an external object, the display 6 will be set to its active state, thereby saving electric power. Furthermore, if the external object disappears from the proximity detector 20, the display 6 is again set to its active state in step 140.” Sparre at 12-13.

“The invention may also be combined with known power preservation arrangements, such as automatically turning off the display backlighting after certain time, as described in previous sections.” Sparre at 13.

“1. A portable electric apparatus (1) having a display (6) of the type comprising a liquid crystal, the display having an active state for presenting visual information in response to a supply of electric energy to the liquid crystal layer, the display also having an inactive state, in which less electric energy is supplied to the liquid crystal layer and less visual information consequently is presented, characterized by a proximity detector (20) for detecting the presence of an object in proximity with the apparatus (1) and in response causing the display (6) to enter its inactive state.

2. A portable electric apparatus (1) according to claim 1, wherein the proximity detector (20) operates by detecting infrared (IR) light.

3. A portable electric apparatus (1) according to claim 1, wherein the proximity detector (20) operates by detecting visible light.

4. A portable electric apparatus (1) according to claim 1, wherein the proximity detector (20) operates by detecting thermal energy generated by said object.

	<p>5. A portable electric apparatus (1) according to claim 1, wherein the proximity detector (20) operates by detecting said object by capacitive means.” Sparre at claims 1-5.</p> <p>“9. A portable electric apparatus (1) according to any of claims 1-7, wherein the inactive state of the display (6) is a state, where the display is electrically turned off.” Sparre at claim 9.</p>
<p>[Claim 6] The mobile station as recited in claim 1, wherein the proximity sensor is located proximate to the display.</p>	<p>Sparre discloses that the proximity sensor is located proximate to the display.</p> <p>For example: “A portable electric apparatus (1) has a display (6) of the type comprising a liquid crystal layer. The display has an active state for presenting visual information in response to a supply of electric energy to the liquid crystal layer. The display also has an inactive state, in which less electric energy is supplied to the liquid crystal layer and less visual information consequently is presented. The apparatus (1) also has a proximity detector (20) for detecting the presence of an object in proximity with the apparatus and in response causing the display (6) to enter its inactive state.” Sparre at Abstract.</p> <p>“A proximity detector is provided at the uppermost portion of the front surface of the telephone 1. In the embodiment shown in FIG 1, the proximity detector 20 is located immediately above the display 6 next to the speaker 4. However, the exact location of the proximity detector 20 is not critical but may be varied between many different positions, as long as the functional requirements specified below are satisfied.</p> <p>In one embodiment, the proximity detector 20 is an IR (infrared) detector, which is arranged to emit infrared light from the front surface of the telephone 1 and is arranged to detect infrared light, that has been reflected from an external object located close to the upper portion of front surface of the telephone 1. Hence, as is generally known per se, the proximity detector 20 may measure the intensity of the reflected infrared light and in response determine whether any external object is present in proximity with the detector 20. By establishing a predetermined threshold for the fraction of infrared light reflected back to the proximity detector 20, it is possible to</p>

define a predetermined range, within which any external object will be detected by the proximity detector 20. Obviously, such a threshold will depend on i.a. the surface structure and material of the external object in question. However, such an issue is regarded nothing more than a practical parameter, which in an actual application will have to be tested, evaluated and determined by a skilled person. Proximity detectors as such are generally known and are commercially available on the market in large numbers .

According to an alternative embodiment, if the mobile telephone is equipped with an IR interface for wireless data communication with external devices (such as a handheld computer) , the IR transmitter thereof may be used also for the purpose of transmitting IR light to be detected by the proximity detector 20.

Alternatively, the proximity detector 20 may operate by emitting and detecting visible light, by detecting thermal energy generated by the external object, or by detecting the external object by capacitive means.” Sparre at 9-10.

1/2

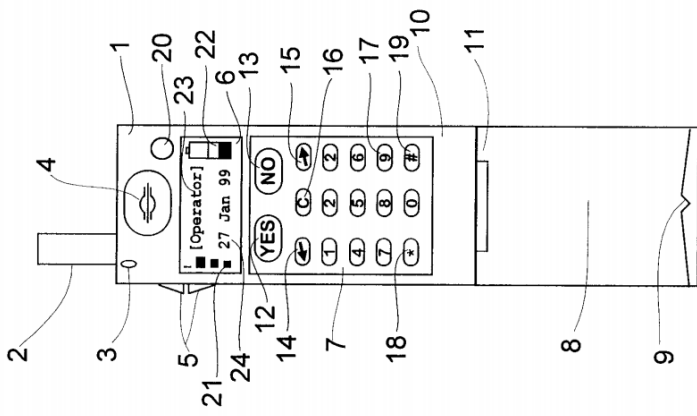
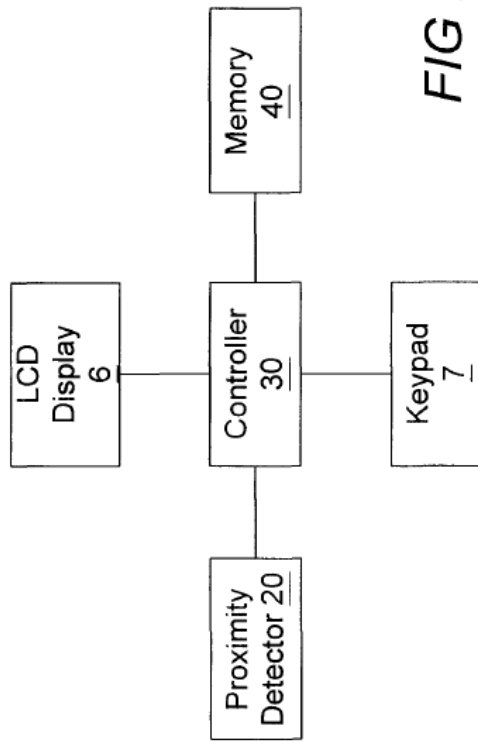

FIG 1

Sparre at Fig. 1.

“The main components of the mobile telephone 1 are shown in FIG 2. A controller 30 is operatively connected to the display 6, the keypad 7, the proximity detector 20 and a memory 40.” Sparre at 10.



Sparre at Fig. 2.

“1. A portable electric apparatus (1) having a display (6) of the type comprising a liquid crystal, the display having an active state for presenting visual information in response to a supply of electric energy to the liquid crystal layer, the display also having an inactive state, in which less electric energy is supplied to the liquid crystal layer and less visual information consequently is presented, characterized by a proximity detector (20) for detecting the presence of an object in proximity with the apparatus (1) and in response causing the display (6) to enter its inactive state.” Sparre at claim 1.

“6. A portable electric apparatus (1) according to any preceding claim, the apparatus having a front surface (10) at which the display (6) is located, wherein the proximity detector (20) is located at said front surface.” Sparre at claim 6.

[Claim 8 – Preamble] 8. A method of conserving battery power in a mobile station, comprising:

Sparre discloses a method of conserving battery power in a mobile station.

For example: *see* discussion of claim 1, *supra*, which is incorporated herein by reference.

“A PORTABLE ELECTRIC APPARATUS HAVING A LIQUID CRYSTAL DISPLAY, AND A POWER PRESERVATION METHOD FOR SUCH AN APPARATUS.” Sparre at Title.

“11. A method of preserving power for a portable electric apparatus (1) having a display (6) of the type comprising a liquid crystal layer, the display having an active state for presenting visual information in response to a supply of electric energy to the liquid crystal layer, the display also having an inactive state, in which less electric energy is supplied to the liquid crystal layer and less visual information consequently is presented, characterized by the steps of determining whether an object is present in proximity with the apparatus (1) , and, if so, causing the display (6) to enter its inactive state.” Sparre at claim 11.

“The present invention relates to a portable electric apparatus having a display of the type comprising a liquid crystal layer, the display having an active state for presenting visual information in response to a supply of electric energy to the liquid crystal layer, the display also having an inactive state, in which less electric energy is supplied to the liquid crystal layer and less visual information consequently is presented. More specifically, the invention is directed at a new and inventive way of preserving electric power in such a portable electric apparatus by bringing the display to its inactive state whenever appropriate. The invention also relates to a method of preserving power for such an apparatus.” Sparre at 1.

“Examples of portable electric apparatuses as set out above are for instance mobile or cellular telephones, wireless telephone handsets, personal communicators, portable digital assistants, palmtop computers, etc. The users thereof are dependent of a fully functional apparatus. More specifically, one of the most common problems in this respect is the limited operational duration between subsequent chargings of a battery used for supplying power to the apparatus. While it has been possible to reach reduced power consumption through the development of low-voltage, high-density integrated

circuits, battery capacity is still a major obstacle against full user freedom in terms of virtually unlimited operational duration. Consequently, preservation of electric power is still a very important issue within the field of portable electric apparatuses. For the rest of this document, reference is made to a mobile telephone, which is chosen to represent a portable electric apparatus according to the invention. However, the invention shall in no way be limited to merely a mobile telephone. In a mobile telephone, the liquid crystal display (LCD) is responsible for a significant part of the total power consumption thereof.” Sparre at 1-2.

“The highest power consumption for a liquid crystal display occurs when an event takes place in the telephone, for instance when a telephone call is generated or ended. In those situations, the visibility of the LCD display is amplified by turning on a back-light illumination of the display. Such back-light illumination consumes too much power than what is acceptable in a long-term perspective. Therefore, back-light illumination is normally restricted to a short time period of a few seconds around the respective event, such as the entering of a telephone number on the keypad, the reception of an incoming call or the termination of an ongoing call (on-hook).

Even if back-light illumination is avoided to a large extent, the display nevertheless consumes electric power also in stand-by mode. The reason for this is that status information has to be presented to the user. Examples of such status information are: current network operator, received signal strength indicator (RSSI), remaining battery capacity, time of day, etc.

Some prior art mobile telephones offer "limited icon mode" during stand-by mode, wherein the display is partially powered off, so that only critical information is displayed. While this approach provides a certain reduction in power consumption, a significant amount of electric power will still be unnecessarily consumed by the display, if the telephone is left in stand-by mode for a long period of time in a bag, a pocket, etc.” Sparre at 3-4.

“The purpose of the present invention is to propose an improved solution to the problem of preserving electric power in a portable electric apparatus having a liquid crystal display. In particular, the invention aims at achieving such power preservation

	<p>at a lower cost and with improved accuracy, as compared to the prior art solutions.” Sparre at 6.</p> <p>“The purpose has also been achieved through a method of preserving power for a portable electric apparatus having a display of the type comprising a liquid crystal layer, the display having an active state for presenting visual information in response to a supply of electric energy to the liquid crystal layer, the display also having an inactive state, in which less electric energy is supplied to the liquid crystal layer and less visual information consequently is presented, by the steps of determining whether an object is present in proximity with the apparatus, and, if so, causing the display to enter its inactive state.” Sparre at 7.</p> <p>“The liquid crystal display 6 also has an inactive state, where less or even no electric energy is supplied to the liquid crystal layer and, thus, less visual information is presented on the display. In contrast to the active state, during which all graphical information (e.g. the icons 21-24) is presented on the display, only parts of this graphical information is shown on the display during its inactive state. For instance, with reference to FIG 1, only the remaining battery charge indicator 22 (but not the icons 21, 22 or 24) is presented on the display 6 during its inactive state. Such an inactive state essentially corresponds to the "limited icon mode", which was described in the Prior Art section of this document. Alternatively, the liquid crystal display 6 may be completely turned off in its inactive state (i.e., no electric energy is supplied to the liquid crystal layer, wherein the power consumption of the display is essentially zero).” Sparre at 9.</p> <p>“The invention may also be combined with known power preservation arrangements, such as automatically turning off the display backlighting after certain time, as described in previous sections.” Sparre at 13.</p>
<p>[8a] detecting whether an external object is proximate;</p>	<p>Sparre discloses detecting whether an external object is proximate.</p>

	<p>For example: <i>see</i> discussion of claim element [1b], <i>supra</i>, which is incorporated herein by reference.</p>
<p>[8b] determining whether a telephone call is active; and</p>	<p>Sparre discloses determining whether a telephone call is active.</p> <p>For example: <i>see</i> discussion of claim element [1d], <i>supra</i>, which is incorporated herein by reference.</p> <p>To the extent Sparre is deemed to not expressly disclose this claim element, Sparre inherently discloses this claim element. <i>See</i> discussion of claim element [1d], <i>supra</i>, which is incorporated herein by reference.</p> <p>To the extent Sparre is deemed to not expressly or inherently disclose this claim element, Sparre renders this claim element obvious to a person of skill in the art at the time of the alleged invention. <i>See</i> discussion of claim element [1d], <i>supra</i>, which is incorporated herein by reference.</p> <p>To the extent Sparre is deemed to not expressly or inherently disclose this claim element, it would be obvious to combine the disclosure of Sparre with those of Fukihar 598 as described in the Fukihar 598 claim chart, which is incorporated herein in its entirety by reference, to disclose this claim element. <i>See</i> discussion of claim element [1d], <i>supra</i>, which is incorporated herein by reference.</p>
<p>[8c] reducing power consumption of a display of the mobile station if (i) a telephone call is determined to be active and (ii) the proximity of the external object is detected; wherein:</p>	<p>Sparre discloses reducing power consumption of a display of the mobile station if (i) a telephone call is determined to be active and (ii) the proximity of the external object is detected.</p> <p>For example: <i>see</i> discussion of claim element [1f], <i>supra</i>, which is incorporated herein by reference.</p>

	<p>To the extent Sparre is deemed to not expressly disclose this claim element, Sparre inherently discloses this claim element. <i>See</i> discussion of claim element [1f] and [1h], <i>supra</i>, which are incorporated herein by reference.</p> <p>To the extent Sparre is deemed to not expressly or inherently disclose this claim element, Sparre renders this claim element obvious to a person of skill in the art at the time of the alleged invention. <i>See</i> discussion of claim elements [1f] and [1h], <i>supra</i>, which are incorporated herein by reference.</p> <p>To the extent Sparre is deemed to not expressly or inherently disclose this claim element, it would be obvious to combine the disclosure of Sparre with those of Fukihar 598 as described in the Fukihar 598 claim chart, which is incorporated herein in its entirety by reference, to disclose this claim element. <i>See</i> discussion of claim elements [1f] and [1h], <i>supra</i>, which are incorporated herein by reference.</p>
<p>[8d] the telephone call is a wireless telephone call;</p>	<p>Sparre discloses that the telephone call is a wireless telephone call.</p> <p>For example: <i>see</i> discussion of claim element [1g], <i>supra</i>, which is incorporated herein by reference.</p>
<p>[8e] the power consumption of the display is reduced while the proximity of the external object is detected only if the wireless telephone call is determined to be active; and</p>	<p>Sparre discloses that the power consumption of the display is reduced while the proximity of the external object is detected only if the wireless telephone call is determined to be active.</p> <p>For example: <i>see</i> discussion of claim element [1f], <i>supra</i>, which is incorporated herein by reference.</p> <p>To the extent Sparre is deemed to not expressly disclose this claim element, Sparre inherently discloses this claim element. <i>See</i> discussion of claim element [1f] and [1h], <i>supra</i>, which are incorporated herein by reference.</p>

	<p>To the extent Sparre is deemed to not expressly or inherently disclose this claim element, Sparre renders this claim element obvious to a person of skill in the art at the time of the alleged invention. <i>See</i> discussion of claim elements [1f] and [1h], <i>supra</i>, which are incorporated herein by reference.</p> <p>To the extent Sparre is deemed to not expressly or inherently disclose this claim element, it would be obvious to combine the disclosure of Sparre with those of Fukihar 598 as described in the Fukihar 598 claim chart, which is incorporated herein in its entirety by reference, to disclose this claim element. <i>See</i> discussion of claim elements [1f] and [1h], <i>supra</i>, which are incorporated herein by reference.</p>
<p>[8f] detecting whether an external object is proximate begins substantially concurrently with the mobile station initiating an outgoing wireless telephone call or receiving an incoming wireless telephone call.</p>	<p>Sparre discloses that detecting whether an external object is proximate begins substantially concurrently with the mobile station initiating an outgoing wireless telephone call or receiving an incoming wireless telephone call.</p> <p>For example: <i>see</i> discussion of claim element [1i], <i>supra</i>, which is incorporated herein by reference.</p> <p>To the extent Sparre is deemed to not expressly disclose this claim element, Sparre inherently discloses this claim element. <i>See</i> discussion of claim element [1i], <i>supra</i>, which is incorporated herein by reference.</p> <p>To the extent Sparre is deemed to not expressly or inherently disclose this claim element, Sparre renders this claim element obvious to a person of skill in the art at the time of the alleged invention. <i>See</i> discussion of claim element [1i], <i>supra</i>, which is incorporated herein by reference.</p> <p>To the extent Sparre is deemed to not expressly or inherently disclose this claim element, it would be obvious to combine the disclosure of Sparre with those of Fukihar 598 as described in the Fukihar 598 claim chart, which is incorporated herein in its entirety by reference, to disclose this claim element. <i>See</i> discussion of claim element [1i], <i>supra</i>, which is incorporated herein by reference.</p>

<p>[Claim 12] The method as recited in claim 8, wherein the detecting of the proximity of the external object is performed by a mechanical proximity sensor, an optical sensor, or a range-detecting sensor.</p>	<p>Sparre discloses that the detecting of the proximity of the external object is performed by a mechanical proximity sensor, an optical sensor, or a range-detecting sensor.</p> <p>For example: <i>see</i> discussion of claim 5, <i>supra</i>, which is incorporated herein by reference.</p>
--	---

Exhibit A1

**Exhibit #A1 – Fukiharu 598
to Defendants’ Preliminary Invalidity Contentions**

**Invalidity Chart for U.S. Patent No. 7,319,889
Japanese Unexamined Patent Application Publication No. 2000-106598 (“Fukiharu 598”)**

Japanese Unexamined Patent Application Publication No. 2000-106598 to Fukiharu (“Fukiharu 598”) was published on April 11, 2000. Fukiharu 598 is prior art to the ’889 Patent under at least pre-AIA §§ 102(a), 102(b), and 102(c). Fukiharu 598 anticipates or renders obvious, alone or in combination with other prior art references, each of the Asserted Claims of the ’889 Patent as described in the chart below and in the main invalidity contentions document to which this chart is annexed.

It would have been obvious under 35 U.S.C. § 103 to a person having ordinary skill in the art at the time of the alleged invention to combine the teachings of Fukiharu 598 with the following references:

1. Japanese Unexamined Patent Application Publication No. H11-220432 (“Numazawa”). Numazawa qualifies as prior art under at least pre-AIA §§ 102(a), 102(b), and 102(c). Numazawa was published on August 10, 1999.
2. World Intellectual Property Organization Publication No. WO 00/78012 to Sparre (“Sparre”). Sparre qualifies as prior art under at least pre-AIA §§ 102(b) and 102(c). Sparre was filed on June 8, 2000 and published on December 21, 2000.
3. US. Patent Application Publication No. 2004/0225904 A1 to Perez et al. (“Perez”). Perez qualifies as prior art under at least pre-AIA § 102(c). Perez was filed on May 6, 2003 and published on November 11, 2004.
4. U.K. Patent Application No. 2,357,400 to Mantjarvi et al. (“Mantjarvi”). Mantjarvi qualifies as prior art under at least under at least pre-AIA §§ 102(b), 102(c). Mantjarvi was filed on December 17, 1999 and published on June 20, 2001
5. U.S. Patent No. 5,010,566 to Seo (“Seo”). Seo qualifies as prior art under at least pre-AIA 35 U.S.C. §§ 102(a), 102(b), and 102(c). Seo was filed on September 7, 1989 and issued on April 23, 1991.

<u>Asserted Claims</u>	<u>Corresponding Disclosure in the Prior Art Reference(s)</u>
[Claim 1 – Preamble] 1. A mobile station, comprising:	<p>Fukiharu 598 discloses a mobile station.</p> <p>For example:</p> <p>“Mobile telephone with Lighting Device, and Method for Control Said Lighting Device.” Fukiharu 598 at Title of the Invention.</p>

“However, mobile telephones assume mobility, and thus the use batteries, or lightweight batteries, to supply power, and thus the fact is that a method is used wherein the circuit operation also consumes as little electric power as possible. However, most of the various types of commercially available mobile telephones today have arrived at a point wherein mobile telephones have been developed that are equipped with, in addition to the traditional voice communication functions of telephones, multi-functionality equipped with so-called liquid crystal display devices, enabling, for example, reception and transmission of text data, and, additionally, are equipped with lighting devices (backlights) in the liquid crystal display devices and keypad portions, because at night, or in a state wherein the lighting is poor, liquid crystal display devices or keypad portions would be difficult to read and to operate.” Fukiharu 598 at ¶ 0003.

“FIG. 1 is an external view of a mobile telephone with a touch sensor, depicting an embodiment according to the present invention” Fukiharu 598 at ¶ 0011.

“

[FIG. 1]

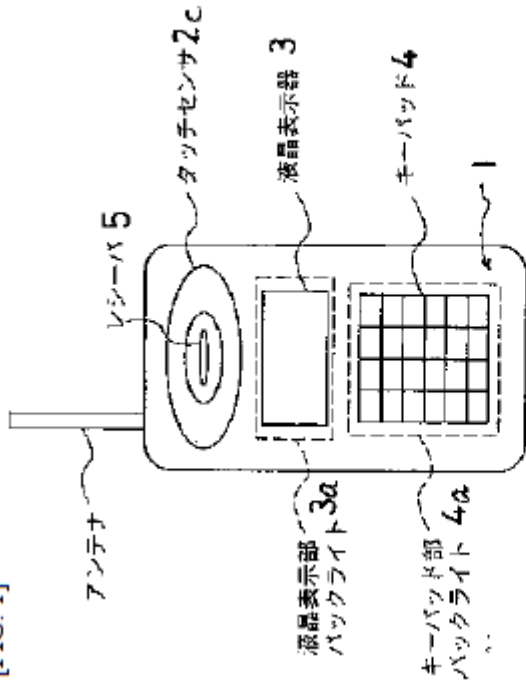

タッチセンサ付き携帯電話機の外観図

[UPPER LEFT] Antenna

5: Receiver

2c: Touch Sensor

3: Liquid Crystal Display Device

4: Keypad

4a: Keypad Portion Backlight

3a: Liquid Crystal Display Portion Backlight

[BOTTOM] Exterior View of Mobile Telephone with Touch Sensor

”

Fukiharu 598 at Fig. 1.

“In the figures, 1 is a mobile telephone, where, in this mobile telephone 1 a lighting device (backlight) 3a of a liquid crystal display device 3 that is controlled by lighting controlling means 2 that are built into the interior of this mobile telephone 1, and a lighting device (backlight) 4a of a keypad 4, are provided, where data, such as text or symbols, that is displayed, or received, on the liquid crystal display device 3 and

	<p>the keypad portion 4 can be read clearly through the lighting from both of these lighting devices (backlights) 3a and 4a.” Fukiharu 598 at ¶ 0012.</p> <p>“The present invention, through the use of a structure as described above, enables a reduction in the consumption of battery power, through enabling the lighting devices to be turned OFF when the ear is caused to contact the receiver portion in order to hear the receiver sound during voice communications of a mobile telephone when the lighting devices (backlights) for a liquid crystal display device and keypad portion of a mobile telephone are lit, such as that night.” Fukiharu 598 at ¶ 0018.</p> <p>“A mobile telephone with a lighting device, equipped with a lighting device (backlight) on a liquid crystal display device and/or a keypad portion, comprising: lighting controlling means made from a controlling portion, a lighting device ON/OFF circuit portion, and a touch sensor, wherein: the lighting device (backlight) can be turned ON and OFF by the lighting controlling means.” Fukiharu 598 at Claim 1.</p>
<p>[1a] a display;</p>	<p>Fukiharu 598 discloses a display.</p> <p>For example:</p> <p>“The present invention relates to a lighting device controlling method for a mobile telephone that is light weight and has good portability, and that achieves a reduction in the consumption of electric power through controlling, through a touch sensor that is provided on a receiver portion section, the activation of a lighting device (backlight) for a liquid crystal display device or keypad portion that is equipped in the mobile telephone.” Fukiharu 598 at ¶ 0001.</p> <p>“However, mobile telephones assume mobility, and thus the use batteries, or lightweight batteries, to supply power, and thus the fact is that a method is used wherein the circuit operation also consumes as little electric power as possible. However, most of the various types of commercially available mobile telephones today have arrived at a point wherein mobile telephones have been developed that are equipped with, in addition to the traditional voice communication functions of</p>

telephones, multi-functionality equipped with so-called liquid crystal display devices, enabling, for example, reception and transmission of text data, and, additionally, are equipped with lighting devices (backlights) in the liquid crystal display devices and keypad portions, because at night, or in a state wherein the lighting is poor, liquid crystal display devices or keypad portions would be difficult to read and to operate.” Fukiharu 598 at ¶ 0003.

“In the figures, 1 is a mobile telephone, where, in this mobile telephone 1 a lighting device (backlight) 3a of a liquid crystal display device 3 that is controlled by lighting controlling means 2 that are built into the interior of this mobile telephone 1, and a lighting device (backlight) 4a of a keypad portion 4, are provided, where data, such as text or symbols, that is displayed, or received, on the liquid crystal display device 3 and the keypad portion 4 can be read clearly through the lighting from both of these lighting devices (backlights) 3a and 4a.” Fukiharu 598 at ¶ 0012.

“

[FIG. 1]

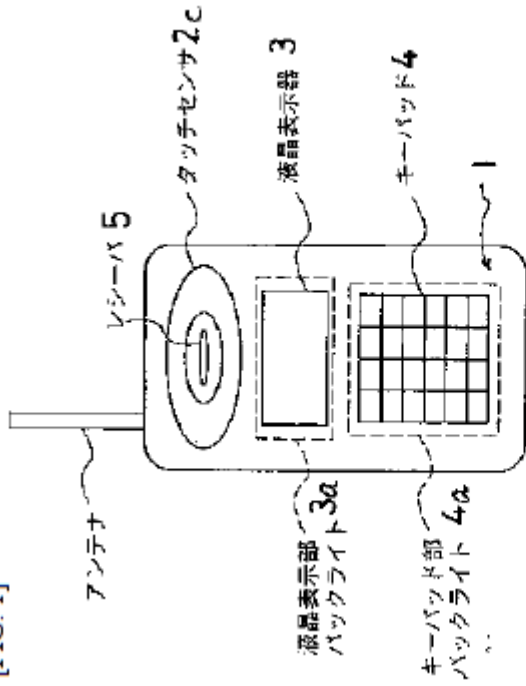

タッチセンサ付き携帯電話機の外観図

[UPPER LEFT] Antenna

5: Receiver

2c: Touch Sensor

3: Liquid Crystal Display Device

4: Keypad

4a: Keypad Portion Backlight

3a: Liquid Crystal Display Portion Backlight

[BOTTOM] Exterior View of Mobile Telephone with Touch Sensor

”

Fukiharu 598 at Fig. 1.

“In the figures, 1 is a mobile telephone, where, in this mobile telephone 1 a lighting device (backlight) 3a of a liquid crystal display device 3 that is controlled by lighting controlling means 2 that are built into the interior of this mobile telephone 1, and a lighting device (backlight) 4a of a keypad portion 4, are provided, where data, such as

text or symbols, that is displayed, or received, on the liquid crystal display device 3 and the keypad portion 4 can be read clearly through the lighting from both of these lighting devices (backlights) 3a and 4a.” Fukiharu 598 at ¶ 0012.

“

[FIG. 2]

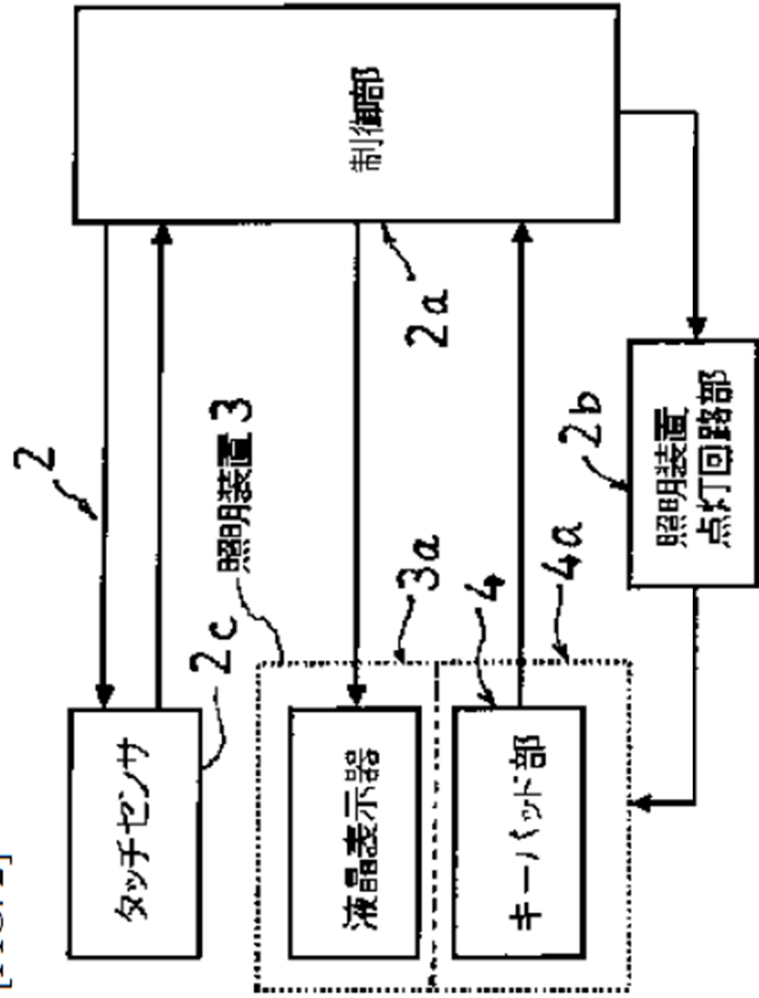

2c: Touch Sensor

3: Lighting Device

3a: Liquid Crystal Display Device

4: Keypad Portion

2a: Controlling Portion

2b: Lighting Device ON/OFF Circuit Portion

Fukiharu 598 at Fig. 2.

	<p>“A mobile telephone with a lighting device, equipped with a lighting device (backlight) on a liquid crystal display device and/or a keypad portion, comprising: lighting controlling means made from a controlling portion, a lighting device ON/OFF circuit portion, and a touch sensor, wherein: the lighting device (backlight) can be turned ON and OFF by the lighting controlling means.” Fukiharu 598 at Claim 1.</p>
<p>[1b] a proximity sensor adapted to generate a signal indicative of proximity of an external object; and</p>	<p>Fukiharu 598 discloses a proximity sensor adapted to generate a signal indicative of proximity of an external object.</p> <p>For example:</p> <p>“The object of the present invention is to provide a mobile telephone with a lighting device, and a method for controlling said lighting device, with improved portability through reducing the weight and volume of the battery, and to enable a thorough increase in talk time and standby time, through controlling, through a touch sensor that is provided on a receiver portion surface of the mobile telephone, operation of a lighting device (backlight) of a liquid crystal display device and/or a keypad portion.” Fukiharu 598 at Abstract.</p> <p>“The present invention relates to a lighting device controlling method for a mobile telephone that is light weight and has good portability, and that achieves a reduction in the consumption of electric power through controlling, through a touch sensor that is provided on a receiver portion section, the activation of a lighting device (backlight) for a liquid crystal display device or keypad portion that is equipped in the mobile telephone.” Fukiharu 598 at ¶ 0001.</p> <p>“The present invention is to solve the problem set forth above, and the object thereof is to provide a lighting device controlling method for a mobile telephone with improved portability through reducing the weight and volume of the battery, and to</p>

enable a thorough increase in talk time and standby time, through controlling, through a touch sensor that is provided on a receiver portion surface of the mobile telephone, operation of a lighting device (backlight) of a liquid crystal display device and/or a key pad portion.” Fukiharu 598 at ¶ 0006.

“Second, a touch sensor that structures the lighting controlling means is activated by the touch sensor contacting a portion of the human body, such as an ear, when listening to the receiver portion. Third, the touch sensor is disposed on the periphery of the receiver of the mobile telephone. Fourth, ON/OFF of the lighting device (backlight) is controlled through a signal that is sent from the controlling portion through a lighting device ON/OFF circuit portion.” Fukiharu 598 at ¶ 0008.

“If in the voice communication mode, a touch sensor 2c is placed into an operating state by a signal from the controlling portion 2a, and constantly outputs a detection output to the controlling portion 2a. If the touch sensor 2c contacts a portion of the human body, such as an ear, a lighting-OFF signal is outputted to the lighting device ON/OFF circuit portion 2b from the controlling portion 2a through the ON output of the touch sensor 2c, and the power supplies to both the lighting device (backlight) 3a and the lighting device (backlight) 4a go to the OFF state, and this lighting-OFF state is maintained until the touch sensor 2c goes into a non-contact state.” Fukiharu 598 at ¶ 0015.

“FIG. 1 is an external view of a mobile telephone with a touch sensor, depicting an embodiment according to the present invention; . . .” Fukiharu 598 at ¶ 0011.

“

[FIG. 1]

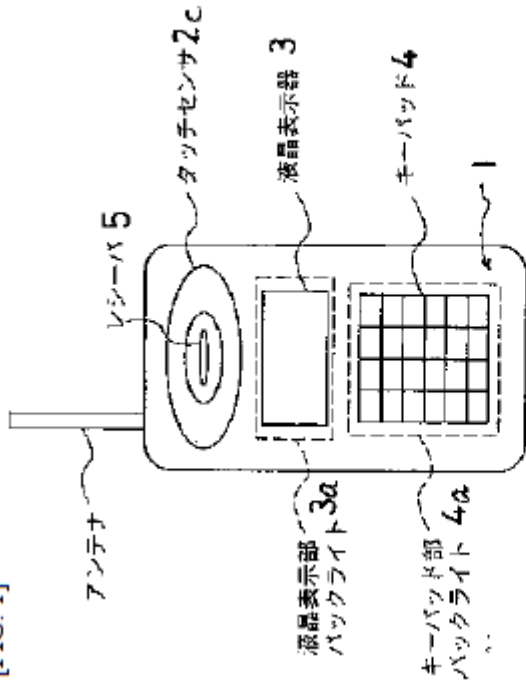

タッチセンサ付き携帯電話機の外観図

[UPPER LEFT] Antenna

5: Receiver

2c: Touch Sensor

3: Liquid Crystal Display Device

4: Keypad

4a: Keypad Portion Backlight

3a: Liquid Crystal Display Portion Backlight

[BOTTOM] Exterior View of Mobile Telephone with Touch Sensor

”

Fukiharu 598 at Fig. 1.

“

[FIG. 2]

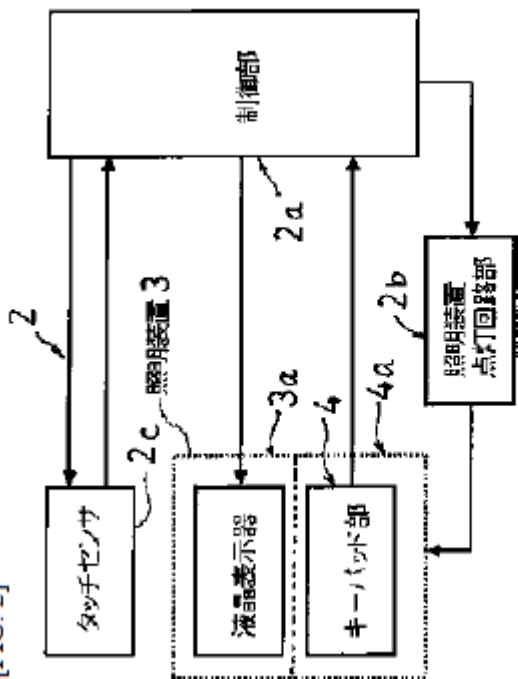

- 2c: Touch Sensor
- 3: Lighting Device
- 3a: Liquid Crystal Display Device
- 4: Keypad Portion
- 2a: Controlling Portion
- 2b: Lighting Device ON/OFF Circuit Portion

Fukiharu 598 at Fig. 2.

“If the touch sensor 2c contacts a portion of the human body, such as an ear, a lighting-OFF signal is outputted to the lighting device ON/OFF circuit portion 2b from the controlling portion 2a through the ON output of the touch sensor 2c, and the power supplies to both the lighting device (backlight) 3a and the lighting device (backlight) 4a go to the OFF state, and this lighting-OFF state is maintained until the touch sensor 2c goes into a non-contact state.” ¶ 0015.

	<p>“A mobile telephone with a lighting device, equipped with a lighting device (backlight) on a liquid crystal display device and/or a keypad portion, comprising: lighting controlling means made from a controlling portion, a lighting device ON/OFF circuit portion, and a touch sensor, wherein: the lighting device (backlight) can be turned ON and OFF by the lighting controlling means.” Fukiharu 598 at Claim 1.</p> <p>“A mobile telephone with a lighting device as set forth in Claim 1, wherein: a touch sensor that structures the lighting controlling means is activated by the touch sensor contacting a portion of the human body, such as an ear, when listening to the receiver portion.” Fukiharu 598 at Claim 2.</p> <p>“A mobile telephone with a lighting device as set forth in Claim 1, wherein: the touch sensor is disposed on the periphery of the receiver of the mobile telephone.” Fukiharu 598 at Claim 3.</p>
<p>[1c] a microprocessor adapted to:</p>	<p>Fukiharu 598 discloses a microprocessor.</p> <p>For example:</p> <p>“First, a mobile telephone device equipped with a lighting device (backlight) on a liquid crystal display device and/or a keypad portion, comprising: lighting controlling means made from a controlling portion, a lighting device ON/OFF circuit portion, and a touch sensor, wherein the lighting device (backlight) can be turned ON and OFF by the lighting controlling means.” Fukiharu 598 at ¶ 0007.</p>

“Fourth, ON/OFF of the lighting device (backlight) is controlled through a signal that is sent from the controlling portion through a lighting device ON/OFF circuit portion.” Fukiharu 598 at ¶ 0008.

“Fifth, a power supply for a mobile telephone is turned ON through pressing of a power supply button of a keypad portion, and, through pressing of a lighting device switch (SW) of a keypad portion, a lighting-ON signal is outputted to a lighting device ON/OFF circuit portion from a controlling portion, to cause the lighting device (backlight) to light, where if not in a voice communication mode, a lighting-ON state is maintained, but if in a voice communication mode, a touch sensor is placed into an operating state by a signal from a controlling portion, and a normal detection output is outputted to the controlling portion and, in addition, if a portion of a human body, such as an ear, makes contact with the touch sensor, a lighting-OFF signal is outputted to the lighting device ON/OFF circuit portion from the controlling portion through an ON output from the touch sensor, to cause the power supply of the lighting device (backlight) to go into the OFF state, and the lighting-OFF state is maintained until the touch sensor is no longer contacted.” Fukiharu 598 at ¶ 0009.

“In the figures, 1 is a mobile telephone, where, in this mobile telephone 1 a lighting device (backlight) 3a of a liquid crystal display device 3 that is controlled by lighting controlling means 2 that are built into the interior of this mobile telephone 1, and a lighting device (backlight) 4a of a keypad portion 4, are provided, where data, such as text or symbols, that is displayed, or received, on the liquid crystal display device 3 and the keypad portion 4 can be read clearly through the lighting from both of these lighting devices (backlights) 3a and 4a.” Fukiharu 598 at ¶ 0012.

“Moreover, the lighting controlling means 2, as with the example depicted in FIG. 2, is structured from a controlling portion 2a, a lighting device ON/OFF circuit portion 2b,

a touch sensor 2c, a lighting device (backlight) 3a of a liquid crystal display device 3, and a lighting device (backlight) 4a of a keypad portion 4.” Fukiharu 598 at ¶ 0013.

“

[FIG. 2]

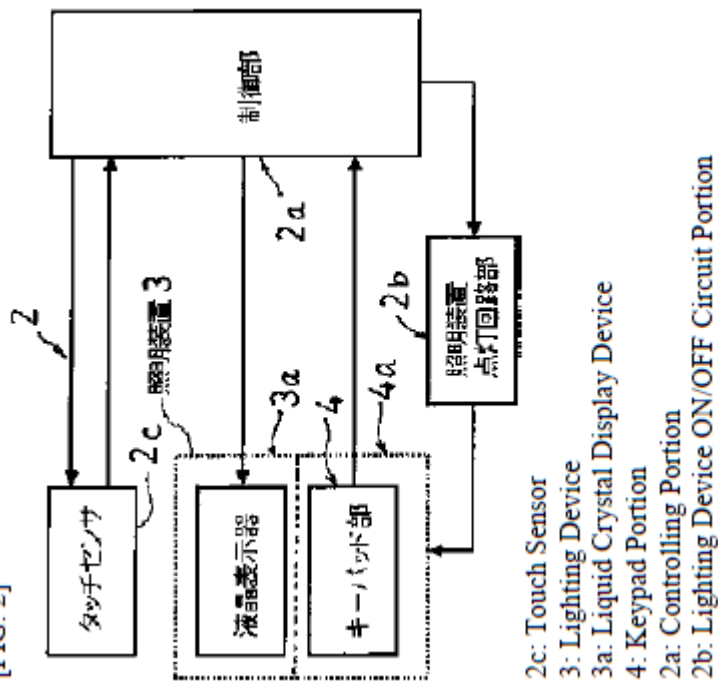

- 2c: Touch Sensor
- 3: Lighting Device
- 3a: Liquid Crystal Display Device
- 4: Keypad Portion
- 2a: Controlling Portion
- 2b: Lighting Device ON/OFF Circuit Portion

”

Fukiharu 598 at Fig. 2.

“Moreover, the configuration is such that the ON/OFF control of the two, the lighting device (backlight) 3a and the lighting device (backlight) 4a, described above, is

controlled through a signal sent from the controlling portion 2a through a lighting device ON/OFF circuit portion 2b. The control method according to the present invention will be explained below, based on the configuration described above. First, the power supply of the mobile telephone 1 is turned ON through pressing of a power supply button of the keypad portion 4. Through a user pressing a lighting switch (SW) of the keypad portion 4, a lighting-ON signal is outputted from the controlling portion 2a to the lighting device ON/OFF circuit portion 2b, causing the lighting device (backlight) 3a and the lighting device (backlight) 4a to become illuminated.” Fukiharu 598 at ¶ 0014.

“If in the voice communication mode, a touch sensor 2c is placed into an operating state by a signal from the controlling portion 2a, and constantly outputs a detection output to the controlling portion 2a. If the touch sensor 2c contacts a portion of the human body, such as an ear, a lighting-OFF signal is outputted to the lighting device ON/OFF circuit portion 2b from the controlling portion 2a through the ON output of the touch sensor 2c, and the power supplies to both the lighting device (backlight) 3a and the lighting device (backlight) 4a go to the OFF state, and this lighting-OFF state is maintained until the touch sensor 2c goes into a non-contact state. Moreover, when the touch sensor 2c goes from a contact state to a non-contact state, a lighting-ON signal is outputted from the controlling portion 2a to the lighting device ON/OFF circuit portion 2b through the OFF output from the touch sensor 2c, and both the lighting device (backlight) 3a and the lighting device (backlight) 4a go into the ON state, and the lighting-ON state is maintained.” ¶ 0015.

“A mobile telephone with a lighting device, equipped with a lighting device (backlight) on a liquid crystal display device and/or a keypad portion, comprising: lighting controlling means made from a controlling portion, a lighting device ON/OFF circuit portion, and a touch sensor, wherein: the lighting device (backlight) can be turned ON and OFF by the lighting controlling means.” Fukiharu 598 at Claim 1.

“A mobile telephone with a lighting device as set forth in Claim 1, configured so that: ON/OFF of the lighting device (backlight) is controlled through a signal that is sent from the controlling portion through a lighting device ON/OFF circuit portion.” Fukiharu 598 at Claim 4.

To the extent Fukiharu 598 is deemed to not expressly disclose a “microprocessor adapted to,” Fukiharu 598 inherently discloses this limitation. Fukiharu 598 discloses a mobile telephone with a controlling means 2, controlling portion 2a, and lighting device ON/OFF circuit portion 2b. Microprocessors (such as the ARM7TDMI) were widely implemented in mobile stations at the time of the alleged invention as a control means. *See, e.g.,* S. Segars, “The ARM9 family-high performance microprocessors for embedded applications”, Proc. ICCD, pp. 230-235, 1998-Oct. A person of ordinary skill in the art at the time of the alleged invention would therefore understand Fukiharu 598 to necessarily disclose a “microprocessor adapted to.”

To the extent Fukiharu 598 is deemed to not expressly or inherently disclose “a microprocessor,” Fukiharu 598 renders it obvious to one of skill in the art to use “a microprocessor.” A person of ordinary skill in the art at the time of the alleged invention would understand that the functionality of controlling means 2, controlling portion 2a, and/or lighting device ON/OFF circuit portion 2b could be implemented using a microprocessor such as the ARM7TDMI. *See, e.g.,* S. Segars, “The ARM9 family-high performance microprocessors for embedded applications”, Proc. ICCD, pp. 230-235, 1998-Oct.. Doing so would be a design choice driven by a number of different reasons, including that it would support Fukiharu 598’s ability to conserve battery power in mobile stations, and doing so would be within the knowledge and ability of a person of ordinary skill in the art at the time of the alleged invention. The use of a microprocessor would constitute, at least, combining prior art elements according to known methods to yield predictable results, a simple substitution of one known element for another to obtain predictable results, the use of a known technique

to improve similar devices in the same way, the application of a known technique to a known device ready for improvement to yield a predictable result, and obvious to try.

To the extent Fukiharu 598 is deemed to not expressly or inherently disclose “a microprocessor,” it would be obvious to combine the disclosure of Fukiharu 598 with those of Numazawa as described in the Numazawa claim chart, which is incorporated herein in its entirety by reference. Fukiharu 598 and Numazawa are both directed to conserving battery power in mobile stations generally and more particularly at conserving battery power in mobile stations by using sensors to detect when the user of the mobile station is in a call and unlikely to be looking at the display (as when, for example, the proximity sensor detects the user’s ear by the mobile station) and to power off the display of mobile stations at such times. Fukiharu 598 at ¶ 0018 (“The present invention, through the use of a structure as described above, enables a reduction in the consumption of battery power, through enabling the lighting devices to be turned OFF when the ear is caused to contact the receiver portion in order to hear the receiver sound during voice communications of a mobile telephone when the lighting devices (backlights) for a liquid crystal display device and keypad portion of a mobile telephone are lit, such as that night.”); Numazawa at ¶ Abstract (“To achieve reduced power consumption through stopping operation of unnecessary functions during use of a wireless terminal. A CPU 2 identifies start of a call state through a signal from a signal processing portion 3 for controlling communication with a base station, and identifies, through an output signal from detecting means 6, whether or not a user ear is in contact with a terminal. Upon identification of contact of the ear to the terminal, controlling means 8 are caused to stop the supply of electric power, from a power supply 7, to displaying means 9 for providing information to a user, and lighting means 10, such as a black light.”), ¶ 0005-0007 (“In the present invention, control is such that, upon determination that the wireless terminal is in a call, operation of functions believe be unnecessary, due to the user of the terminal being in a call, is stopped, and upon termination of the call, operation of the stopped functions is restarted. Additionally, because it is envisioned that there will also be cases where, even during a call, the face of the user may be separated from the receiver of the terminal, control is performed so as to enable restarting of the operations of the functions that

had been stopped as unnecessary, through detecting whether or not the user of the terminal has the receiver in contact with an ear. The achievement of reduced power consumption through stopping operation of functions that become unnecessary in use of the terminal, as described above, can be anticipated to have the effect of extending the life of the power supply, such as a battery.’). A person of ordinary skill in the art at the time of the alleged invention would be motivated to modify Fukiharu 598 to use “a microprocessor” as disclosed in Numazawa for a number of different reasons, including that it would support Fukiharu 598’s ability to conserve battery power in mobile stations, and doing so would be within the knowledge and ability of a person of ordinary skill in the art at the time of the alleged invention. As a specific example, Numazawa discloses the use of a CPU to send a signal to a controlling means in order for the controlling means to carry out certain functions such as shutting power off to the display of the mobile station. *See* Numazawa at ¶ 0021 (“Following this, in Step S4, the CPU 2 outputs, to the controlling means 8, a signal for stopping the displaying means 9 and the lighting means 10. Through this, the controlling means 8 stop the supply of power from the power supply 7 to the displaying means 9 and the lighting means 10, and the displaying means 9 and lighting means 10 stop operating.’). A person of ordinary skill in the art at the time of the alleged invention would be motivated to improve Fukiharu 598’s “controlling means 2” (and/or controlling portion 2a, and lighting device ON/OFF circuit portion 2b) in the same way by employing the CPU disclosed in Numazawa. The combination would constitute, at least, combining prior art elements according to known methods to yield predictable results, a simple substitution of one known element for another to obtain predictable results, the use of a known technique to improve similar devices in the same way, the application of a known technique to a known device ready for improvement to yield a predictable result, and obvious to try.

To the extent Fukiharu 598 is deemed to not expressly or inherently disclose “a microprocessor,” it would be obvious to combine the disclosure of Fukiharu 598 with those of Sparre as described in the Sparre claim chart, which is incorporated herein in its entirety by reference. Fukiharu 598 and Sparre are both directed to conserving battery power in mobile stations generally and more particularly at conserving battery

power in mobile stations by using sensors to detect when the user of the mobile station is in a call and unlikely to be looking at the display (as when, for example, the proximity sensor detects the user's ear by the mobile station) and to power off the display of mobile stations at such times. Fukiharu 598 at ¶ 0018 (“The present invention, through the use of a structure as described above, enables a reduction in the consumption of battery power, through enabling the lighting devices to be turned OFF when the ear is caused to contact the receiver portion in order to hear the receiver sound during voice communications of a mobile telephone when the lighting devices (backlights) for a liquid crystal display device and keypad portion of a mobile telephone are lit, such as that night.”); Sparre at 6 (“The purpose of the present invention is to propose an improved solution to the problem of preserving electric power in a portable electric apparatus having a liquid crystal display. In particular, the invention aims at achieving such power preservation at a lower cost and with improved accuracy, as compared to the prior art solutions. According to the invention, the portable electric apparatus is provided with a proximity detector, which is arranged to detect when an external object is very close to a specific portion of the apparatus (for instance less than 3 cm from the display). The external object may be the user's ear (when the telephone is held in a normal position for conversation), or the interior walls of a pocket or bag, in which the telephone has been placed by the user. In all circumstances, the presence of such an external object indicates that the apparatus is not in a position, where it is useful to keep the display turned on, since the user is physically prevented from visual access to the display. Therefore, when the proximity detector has detected the presence of the external object, the display may be powered off or present less visual information.”). A person of ordinary skill in the art at the time of the alleged invention would be motivated to modify Fukiharu 598 to use “a microprocessor” as disclosed in Sparre for a number of different reasons, including that it would support Fukiharu 598's ability to conserve battery power in mobile stations, and doing so would be within the knowledge and ability of a person of ordinary skill in the art at the time of the alleged invention. As a specific example, Sparre discloses the use of a controller to carry out certain functions in a mobile station such as turning off the display. *See* Sparre at 11 (“... the controller 30 is arranged to bring the liquid crystal display 6 into its inactive state ...”). Sparre further specifically teaches that “[t]he controller 30 may be any microprocessor, central processing unit (CPU) or other piece of electronic logic circuitry already used in the telephone 1 for performing the various functions thereof

(such as telephone call control, keypad control, display control, or execution of utility programs such as a calculator program, electronic game programs, etc).” Sparre at 10-11. A person of ordinary skill in the art at the time of the alleged invention would therefore understand that Fukiharu 598’s “controlling means 2” (and/or controlling portion 2a, and lighting device ON/OFF circuit portion 2b) could be implemented as a CPU/microprocessor, just like the “controller 30” was disclosed to be implemented in Sparre. The combination would constitute, at least, combining prior art elements according to known methods to yield predictable results, a simple substitution of one known element for another to obtain predictable results, the use of a known technique to improve similar devices in the same way, the application of a known technique to a known device ready for improvement to yield a predictable result, and obvious to try.

To the extent Fukiharu 598 is deemed to not expressly or inherently disclose “a microprocessor,” it would be obvious to combine the disclosure of Fukiharu 598 with those of Perez as described in the Perez claim chart, which is incorporated herein in its entirety by reference. Fukiharu 598 and Perez are both directed to conserving battery power in mobile stations generally and more particularly at conserving battery power in mobile stations by using sensors to detect when the user of the mobile station is in a call and unlikely to be looking at the display (as when, for example, the proximity sensor detects the user’s ear by the mobile station) and to power off the display of mobile stations at such times. Fukiharu 598 at ¶ 0018 (“The present invention, through the use of a structure as described above, enables a reduction in the consumption of battery power, through enabling the lighting devices to be turned OFF when the ear is caused to contact the receiver portion in order to hear the receiver sound during voice communications of a mobile telephone when the lighting devices (backlights) for a liquid crystal display device and keypad portion of a mobile telephone are lit, such as that night.”); Perez at ¶ 0013 (“Referring to FIG. 1, a portable communication product 10 such as a cellular phone includes a transceiver radio having a microphone 20, an earpiece 22, a keypad 18 and a display 12 (such as a color display) coupled to the transceiver radio. The portable communication product 10 further includes at least one sensor (24, 26, 28 or 30) and a processor 16. The sensor can be used for detecting a user condition of the portable communication device such as a talk condition when the

user is assumed to be talking on the portable communication device. The processor 16 can be programmed to at least reduce power provided to the display 12 when the sensor detects the talk condition. The processor 16 can also turn off power to the display 12 during a talk condition if desired.”). A person of ordinary skill in the art at the time of the alleged invention would be motivated to modify Fukiharu 598 to use “a microprocessor” as disclosed in Perez for a number of different reasons, including that it would support Fukiahru 598’s ability to conserve battery power in mobile stations, and doing so would be within the knowledge and ability of a person of ordinary skill in the art at the time of the alleged invention. As a specific example, Perez discloses the use of a processor to carry out certain functions such as shutting power off to the display of the mobile station. *See* Perez at ¶ 0021 (“The processor 16 can be programmed to at least reduce power provided to the display 12 when the sensor detects the talk condition. The processor 16 can also turn off power to the display 12 during a talk condition if desired.”). A person of ordinary skill in the art at the time of the alleged invention would be motivated to improve Fukiharu 598’s “controlling means 2” (and/or controlling portion 2a, and lighting device ON/OFF circuit portion 2b) in the same way by employing the processor disclosed in Perez. The combination would constitute, at least, combining prior art elements according to known methods to yield predictable results, a simple substitution of one known element for another to obtain predictable results, the use of a known technique to improve similar devices in the same way, the application of a known technique to a known device ready for improvement to yield a predictable result, and obvious to try.

To the extent Fukiharu 598 is deemed to not expressly or inherently disclose “a microprocessor,” it would be obvious to combine the disclosure of Fukiharu 598 with those of Mantlyarvi as described in the Mantlyarvi claim chart, which is incorporated herein in its entirety by reference. are both directed to conserving battery power in mobile stations generally and more particularly at conserving battery power in mobile stations by using sensors to detect when the user of the mobile station is in a call and unlikely to be looking at the display (as when, for example, the proximity sensor detects the user’s ear by the mobile station) and to power off the display of mobile stations at such times. Fukiharu 598 at ¶ 0018 (“The present invention, through the use of a

structure as described above, enables a reduction in the consumption of battery power, through enabling the lighting devices to be turned OFF when the ear is caused to contact the receiver portion in order to hear the receiver sound during voice communications of a mobile telephone when the lighting devices (backlights) for a liquid crystal display device and keypad portion of a mobile telephone are lit, such as that night.”); Mantiyarvi at 9:5-8 (“The station may also be switched between different modes of operation or even on and off based on the output signal received from the detecting means. The lighting of the keypad and/or the display may be controlled based on this information.”). A person of ordinary skill in the art at the time of the alleged invention would be motivated to modify Fukiharu 598 to use “a microprocessor” as disclosed in Mantiyarvi for a number of different reasons, including that it would support Fukiahru 598’s ability to conserve battery power in mobile stations, and doing so would be within the knowledge and ability of a person of ordinary skill in the art at the time of the alleged invention. As a specific example, Mantiyarvi discloses the use of a processor to carry out certain functions such as shutting power off to the display of the mobile station. *See* Mantiyarvi at 6:10-16 (“Figure 1 shows a mobile station in accordance with an embodiment of the present invention. The mobile station 1 comprises a housing or cover portion 11 which protects and encapsulates the various internal components of the mobile station. The internal components are not shown in greater detail, but may typically comprise components such as a processor 12 that is for controlling one or several functions of the mobile station.”). A person of ordinary skill in the art at the time of the alleged invention would be motivated to improve Fukiharu 598’s “controlling means 2” (and/or controlling portion 2a, and lighting device ON/OFF circuit portion 2b) in the same way by employing the processor disclosed in Mantiyarvi. The combination would constitute, at least, combining prior art elements according to known methods to yield predictable results, a simple substitution of one known element for another to obtain predictable results, the use of a known technique to improve similar devices in the same way, the application of a known technique to a known device ready for improvement to yield a predictable result, and obvious to try.

[1d] (a) determine whether a telephone call is active;

Fukiharu 598 discloses the microprocessor adapted to determine whether a telephone call is active.

For example:

“Fifth, a power supply for a mobile telephone is turned ON through pressing of a power supply button of a keypad portion, and, through pressing of a lighting device switch (SW) of a keypad portion, a lighting-ON signal is outputted to a lighting device ON/OFF circuit portion from a controlling portion, to cause the lighting device (backlight) to light, where if not in a voice communication mode, a lighting-ON state is maintained, but if in a voice communication mode, a touch sensor is placed into an operating state by a signal from a controlling portion, and a normal detection output is outputted to the controlling portion and, in addition, if a portion of a human body, such as an ear, makes contact with the touch sensor, a lighting-OFF signal is outputted to the lighting device ON/OFF circuit portion from the controlling portion through an ON output from the touch sensor, to cause the power supply of the lighting device (backlight) to go into the OFF state, and the lighting-OFF state is maintained until the touch sensor is no longer contacted.” Fukiharu 598 at ¶ 0009.

“Sixth, when the touch sensor goes from a contact state to a non-contact state, a lighting-ON signal is outputted to the lighting device ON/OFF circuit portion from the controlling portion through an OFF output from the touch sensor, so that the power supply for the lighting device (backlight) will go into the ON state, and the lighting-on state is maintained, and, additionally, when, while the touch sensor is in the non-contact state, a non-voice communication mode is entered from the voice communication mode, the power supply to the touch sensor is cut off, producing a non-operating state, and the lighting-on state is maintained.” Fukiharu 598 at ¶ 0010.

“At this time, the lighting-ON state is maintained if not in the voice communication mode. If in the voice communication mode, a touch sensor 2c is placed into an

operating state by a signal from the controlling portion 2a, and constantly outputs a detection output to the controlling portion 2a.” Fukiharu 598 at ¶ 0015.

“Additionally, when the touch sensor 2c is in the noncontact state, if the state changes from the voice communication mode to other than the voice communication mode, the power supply to the touch sensor 2c is cut off, to produce a non-operating state, and the lighting-ON state is maintained.” Fukiharu 598 at ¶ 0016.

“

[FIG. 3]

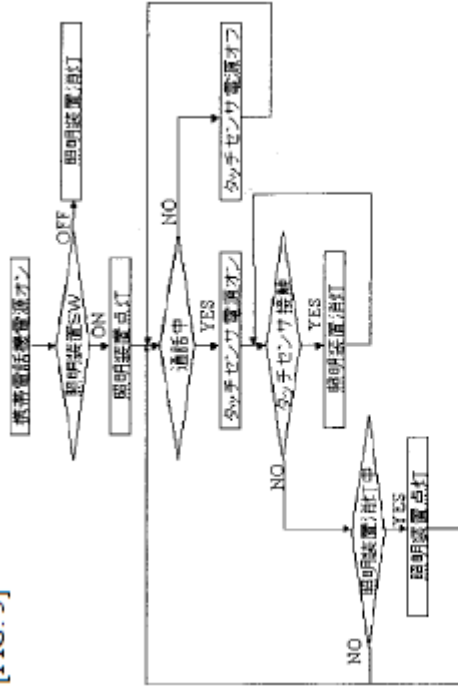

[LOWER LEFT DIAMOND] Lighting device OFF?
 [LOWER LEFT RECTANGLE] Turn lighting device ON.
 [MIDDLE COLUMN, TOP TO BOTTOM]
 Mobile telephone power supply ON
 Lighting device SW?
 Turn lighting device ON.
 Voice communication in process?
 Turn touch sensor power supply ON.
 Touch sensor contacted?
 Turn lighting device OFF.
 [UPPER RIGHT] Turn lighting device OFF.
 [BOTTOM RIGHT] Turn touch sensor power supply OFF. »

Fukiharu 598 at Fig. 3.

“A lighting controlling method for a mobile telephone wherein: the power supply for the mobile telephone is turned ON through pressing of a power supply button of a keypad portion; and through pressing of a lighting device switch (SW) of a keypad portion, a lighting-ON signal is outputted to a lighting device ON/OFF circuit portion

from a controlling portion, to cause the lighting device (backlight) to light, where if not in a voice communication mode, a lighting-ON state is maintained, but if in a voice communication mode, a touch sensor is placed into an operating state by a signal from a controlling portion, and a normal detection output is outputted to the controlling portion and, in addition, if a portion of a human body, such as an ear, makes contact with the touch sensor, a lighting-OFF signal is outputted to the lighting device ON/OFF circuit portion from the controlling portion through an ON output from the touch sensor, to cause the power supply of the lighting device (backlight) to go into the OFF state, and the lighting-OFF state is maintained until the touch sensor is no longer contacted.” Fukiharu 598 at Claim 5.

To the extent Fukiharu 598 is deemed to not expressly disclose the microprocessor adapted to determine whether a telephone call is active, Fukiharu 598 inherently discloses this limitation. In Fukiharu 598, the mobile telephone is able to determine whether it is in voice communication mode. Fukiharu 598 further specifies that the determination of whether the mobile telephone is in voice communication mode is made without use of the touch sensor, as the touch sensor is not placed into an operating state until after the mobile telephone determines that it is in voice communication mode. A person of ordinary skill in the art at the time of the alleged invention would therefore understand that, in order for the mobile phone to determine whether it is in voice communication mode it must necessarily “determine[s] whether a telephone call is active.” Further as noted above for element [1d] and incorporated by reference here, Fukiharu 598 discloses or renders obvious the use of a microprocessor. Therefore, a person of ordinary skill in the art at the time of the alleged invention would understand that necessarily the microprocessor would “determine whether a telephone call is active.”

To the extent Fukiharu 598 is deemed to not expressly or inherently disclose a microprocessor adapted to “determine whether a telephone call is active,” Fukiharu 598 renders it obvious to one of skill in the art at the time of the alleged invention to use a microprocessor adapted to “determine whether a telephone call is active.” In

Fukiharu 598, the mobile telephone is able to determine whether it is in voice communication mode. Fukiharu 598 further specifies that the determination of whether the mobile telephone is in voice communication mode is made without use of the touch sensor, as the touch sensor is not placed into an operating state until after the mobile telephone determines that it is in voice communication mode. It would therefore be obvious to a person of ordinary skill in the art at the time of the alleged invention that Fukiharu 598 could use a microprocessor to determine whether it is in voice communication mode, such that Fukiharu 598 would contain a microprocessor adapted to “determine whether a telephone call is active.”

To the extent Fukiharu 598 is deemed to not expressly or inherently disclose a microprocessor adapted to “determine whether a telephone call is active,” it would be obvious to combine the disclosure of Fukiharu 598 with those of Numazawa as described in the Numazawa claim chart, which is incorporated herein in its entirety by reference. Fukiharu 598 and Numazawa are both directed to conserving battery power in mobile stations generally and more particularly at conserving battery power in mobile stations by using sensors to detect when the user of the mobile station is in a call and unlikely to be looking at the display (as when, for example, the proximity sensor detects the user’s ear by the mobile station) and to power off the display of mobile stations at such times. Fukiharu 598 at ¶ 0018 (“The present invention, through the use of a structure as described above, enables a reduction in the consumption of battery power, through enabling the lighting devices to be turned OFF when the ear is caused to contact the receiver portion in order to hear the receiver sound during voice communications of a mobile telephone when the lighting devices (backlights) for a liquid crystal display device and keypad portion of a mobile telephone are lit, such as that night.”); Numazawa at ¶ Abstract (“To achieve reduced power consumption through stopping operation of unnecessary functions during use of a wireless terminal. A CPU 2 identifies start of a call state through a signal from a signal processing portion 3 for controlling communication with a base station, and identifies, through an output signal from detecting means 6, whether or not a user ear is in contact with a terminal. Upon identification of contact of the ear to the terminal, controlling means 8 are caused to stop the supply of electric power, from a power supply 7, to displaying means

9 for providing information to a user, and lighting means 10, such as a black light.”), ¶ 0005-0007 (“In the present invention, control is such that, upon determination that the wireless terminal is in a call, operation of functions believe be unnecessary, due to the user of the terminal being in a call, is stopped, and upon termination of the call, operation of the stopped functions is restarted. Additionally, because it is envisioned that there will also be cases where, even during a call, the face of the user may be separated from the receiver of the terminal, control is performed so as to enable restarting of the operations of the functions that had been stopped as unnecessary, through detecting whether or not the user of the terminal has the receiver in contact with an ear. The achievement of reduced power consumption through stopping operation of functions that become unnecessary in use of the terminal, as described above, can be anticipated to have the effect of extending the life of the power supply, such as a battery.”). A person of ordinary skill in the art at the time of the alleged invention would therefore be motivated to Fukiharu 598 with Numazawa’s teaching of a microprocessor adapted to “determine whether a telephone call is active,” for a number of different reasons, including that it would support Fukiharu 598’s ability to conserve battery power in mobile stations, and doing so would be within the knowledge and ability of a person of ordinary skill in the art at the time of the alleged invention. As a more specific example, it would be obvious for one of ordinary skill in the art at the time of the alleged invention to use Numazawa’s teaching of “A CPU 2 identifies start of a call state through a signal from a signal processing portion 3 for controlling communication with a base station” to carry out Fukiharu 598’s mobile telephone’s determination that it is in voice communication mode. The combination would constitute, at least, combining prior art elements according to known methods to yield predictable results, a simple substitution of one known element for another to obtain predictable results, the use of a known technique to improve similar devices in the same way, the application of a known technique to a known device ready for improvement to yield a predictable result, and obvious to try.

To the extent Fukiharu 598 is deemed to not expressly or inherently disclose a microprocessor adapted to “determine whether a telephone call is active,” it would be obvious to combine the disclosure of Fukiharu 598 with those of Sparre as described in

the Sparre claim chart, which is incorporated herein in its entirety by reference. Fukiharu 598 and Sparre are both directed to conserving battery power in mobile stations generally and more particularly at conserving battery power in mobile stations by using sensors to detect when the user of the mobile station is in a call and unlikely to be looking at the display (as when, for example, the proximity sensor detects the user's ear by the mobile station) and to power off the display of mobile stations at such times. Fukiharu 598 at ¶ 0018 (“The present invention, through the use of a structure as described above, enables a reduction in the consumption of battery power, through enabling the lighting devices to be turned OFF when the ear is caused to contact the receiver portion in order to hear the receiver sound during voice communications of a mobile telephone when the lighting devices (backlights) for a liquid crystal display device and keypad portion of a mobile telephone are lit, such as that night.”); Sparre at 6 (“The purpose of the present invention is to propose an improved solution to the problem of preserving electric power in a portable electric apparatus having a liquid crystal display. In particular, the invention aims at achieving such power preservation at a lower cost and with improved accuracy, as compared to the prior art solutions. According to the invention, the portable electric apparatus is provided with a proximity detector, which is arranged to detect when an external object is very close to a specific portion of the apparatus (for instance less than 3 cm from the display). The external object may be the user's ear (when the telephone is held in a normal position for conversation), or the interior walls of a pocket or bag, in which the telephone has been placed by the user. In all circumstances, the presence of such an external object indicates that the apparatus is not in a position, where it is useful to keep the display turned on, since the user is physically prevented from visual access to the display. Therefore, when the proximity detector has detected the presence of the external object, the display may be powered off or present less visual information.”). A person of ordinary skill in the art at the time of the alleged invention would therefore be motivated to combine Fukiharu 598 with Sparre's teaching of a microprocessor adapted to “determine whether a telephone call is active,” for a number of different reasons, including that it would support Fukiharu 598's ability to conserve battery power in mobile stations, and doing so would be within the knowledge and ability of a person of ordinary skill in the art at the time of the alleged invention. As a more specific example, Sparre teaches that “the controller 30 has detected that the user has started initiating an outgoing call,” Sparre at 13, and that “[t]he controller 30 may be

any microprocessor, central processing unit (CPU) or other piece of electronic logic circuitry already used in the telephone 1 for performing the various functions thereof' Sparre at 10. It would therefore be obvious to one of ordinary skill in the art at the time of the alleged invention to use the microprocessor disclosed in Sparre to carry out Fukiharu 598's mobile telephone's determination that it is in voice communication mode. The combination would constitute, at least, combining prior art elements according to known methods to yield predictable results, a simple substitution of one known element for another to obtain predictable results, the use of a known technique to improve similar devices in the same way, the application of a known technique to a known device ready for improvement to yield a predictable result, and obvious to try.

To the extent Fukiharu 598 is deemed to not expressly or inherently disclose a microprocessor adapted to "determine whether a telephone call is active," it would be obvious to combine the disclosure of Fukiharu 598 with those of Perez as described in the Perez claim chart, which is incorporated herein in its entirety by reference. Fukiharu 598 and Perez are both directed to conserving battery power in mobile stations generally and more particularly at conserving battery power in mobile stations by using sensors to detect when the user of the mobile station is in a call and unlikely to be looking at the display (as when, for example, the proximity sensor detects the user's ear by the mobile station) and to power off the display of mobile stations at such times. Fukiharu 598 at ¶ 0018 ("The present invention, through the use of a structure as described above, enables a reduction in the consumption of battery power, through enabling the lighting devices to be turned OFF when the ear is caused to contact the receiver portion in order to hear the receiver sound during voice communications of a mobile telephone when the lighting devices (backlights) for a liquid crystal display device and keypad portion of a mobile telephone are lit, such as that night."); Perez at ¶ 0013 ("Referring to FIG. 1, a portable communication product 10 such as a cellular phone includes a transceiver radio having a microphone 20, an earpiece 22, a keypad 18 and a display 12 (such as a color display) coupled to the transceiver radio. The portable communication product 10 further includes at least one sensor (24, 26, 28 or 30) and a processor 16. The sensor can be used for detecting a user condition of the portable communication device such as a talk condition when the user is assumed to be talking

on the portable communication device. The processor 16 can be programmed to at least reduce power provided to the display 12 when the sensor detects the talk condition. The processor 16 can also turn off power to the display 12 during a talk condition if desired.”). A person of ordinary skill in the art at the time of the alleged invention would therefore be motivated to combine Fukiharu 598 with Perez’s teaching of a microprocessor adapted to “determine whether a telephone call is active,” for a number of different reasons, including that it would support Fukiahru 598’s ability to conserve battery power in mobile stations, and doing so would be within the knowledge and ability of a person of ordinary skill in the art at the time of the alleged invention. As a more specific example, Perez teaches that “[a] talk condition, for example, can be sensed by detecting if a predetermined volume of acoustic sound is being received at the microphone 20 or at another sensor such as a proximity sensor 26 indicative of a user talking on the portable communication device” (Perez at ¶ 0015) and that “[t]he processor can be programmed to at least reduce power provided to the display when the sensor detects the talk condition. The processor can also turn off power to the display during a talk condition if desired” (Perez at ¶ 0006). It would therefore be obvious to one of ordinary skill in the art at the time of the alleged invention to use the microprocessor disclosed in Perez to carry out Fukiharu 598’s mobile telephone’s determination that it is in voice communication mode. The combination would constitute, at least, combining prior art elements according to known methods to yield predictable results, a simple substitution of one known element for another to obtain predictable results, the use of a known technique to improve similar devices in the same way, the application of a known technique to a known device ready for improvement to yield a predictable result, and obvious to try.

To the extent Fukiharu 598 is deemed to not expressly or inherently disclose a microprocessor adapted to “determine whether a telephone call is active,” it would be obvious to combine the disclosure of Fukiharu 598 with those of Mantiyarvi as described in the Mantiyarvi claim chart, which is incorporated herein in its entirety by reference. Fukiharu 598 and Mantiyarvi are both directed to conserving battery power in mobile stations generally and more particularly at conserving battery power in mobile stations by using sensors to detect when the user of the mobile station is in a call and

unlikely to be looking at the display (as when, for example, the proximity sensor detects the user's ear by the mobile station) and to power off the display of mobile stations at such times. Fukiharu 598 at ¶ 0018 (“The present invention, through the use of a structure as described above, enables a reduction in the consumption of battery power, through enabling the lighting devices to be turned OFF when the ear is caused to contact the receiver portion in order to hear the receiver sound during voice communications of a mobile telephone when the lighting devices (backlights) for a liquid crystal display device and keypad portion of a mobile telephone are lit, such as that night.”); Mantiyarvi at 9:5-8 (“The station may also be switched between different modes of operation or even on and off based on the output signal received from the detecting means. The lighting of the keypad and/or the display may be controlled based on this information.”). A person of ordinary skill in the art at the time of the alleged invention would therefore be motivated to combine Fukiharu 598 with Mantiyarvi’s teaching of a microprocessor adapted to “determine whether a telephone call is active,” for a number of different reasons, including that it would support Fukiharu 598’s ability to conserve battery power in mobile stations, and doing so would be within the knowledge and ability of a person of ordinary skill in the art at the time of the alleged invention. As a more specific example, Mantiyarvi teaches that “[t]he controller may provide different instructions for the controlled functions depending on the location or the context where the control is provided. For example, during a normal speech call the lighting of the display and/or keyboard may be switched off after a predefined time has lapsed from the activation thereof. However, the lightning will stay on if the connection was established for data communication, such as for a wireless application protocol (WAP) connection or for an Internet connection,” (Mantiyarvi at 14:21-30) and “a processor 12 that is for controlling one or several functions of the mobile station” (Mantiyarvi at 6:15-16.). It would therefore be obvious to one of ordinary skill in the art at the time of the alleged invention to use the microprocessor disclosed in Mantiyarvi to carry out Fukiharu 598’s mobile telephone’s determination that it is in voice communication mode. The combination would constitute, at least, combining prior art elements according to known methods to yield predictable results, a simple substitution of one known element for another to obtain predictable results, the use of a known technique to improve similar devices in the same way, the

	<p>application of a known technique to a known device ready for improvement to yield a predictable result, and obvious to try.</p>
<p>[1e] (b) receive the signal from the proximity sensor; and</p>	<p>Fukiharu 598 discloses the microprocessor adapted to receive the signal from the proximity sensor.</p> <p>For example:</p> <p><i>See</i> discussion of claim element [1b], <i>supra</i>, which is incorporated herein by reference.</p> <p>“The present invention is to solve the problem set forth above, and the object thereof is to provide a lighting device controlling method for a mobile telephone with improved portability through reducing the weight and volume of the battery, and to enable a thorough increase in talk time and standby time, through controlling, through a touch sensor that is provided on a receiver portion surface of the mobile telephone, operation of a lighting device (backlight) of a liquid crystal display device and/or a key pad portion.” Fukiharu 598 at ¶ 0006.</p> <p>“Second, a touch sensor that structures the lighting controlling means is activated by the touch sensor contacting a portion of the human body, such as an ear, when listening to the receiver portion. Third, the touch sensor is disposed on the periphery of the receiver of the mobile telephone. Fourth, ON/OFF of the lighting device (backlight) is controlled through a signal that is sent from the controlling portion through a lighting device ON/OFF circuit portion.” Fukiharu 598 at ¶ 0008.</p> <p>“Fifth, a power supply for a mobile telephone is turned ON through pressing of a power supply button of a keypad portion, and, through pressing of a lighting device switch (SW) of a keypad portion, a lighting-ON signal is outputted to a lighting device ON/OFF circuit portion from a controlling portion, to cause the lighting device</p>

(backlight) to light, where if not in a voice communication mode, a lighting-ON state is maintained, but if in a voice communication mode, a touch sensor is placed into an operating state by a signal from a controlling portion, and a normal detection output is outputted to the controlling portion and, in addition, if a portion of a human body, such as an ear, makes contact with the touch sensor, a lighting-OFF signal is outputted to the lighting device ON/OFF circuit portion from the controlling portion through an ON output from the touch sensor, to cause the power supply of the lighting device (backlight) to go into the OFF state, and the lighting-OFF state is maintained until the touch sensor is no longer contacted.” Fukiharu 598 at ¶ 0009.

[FIG. 2]

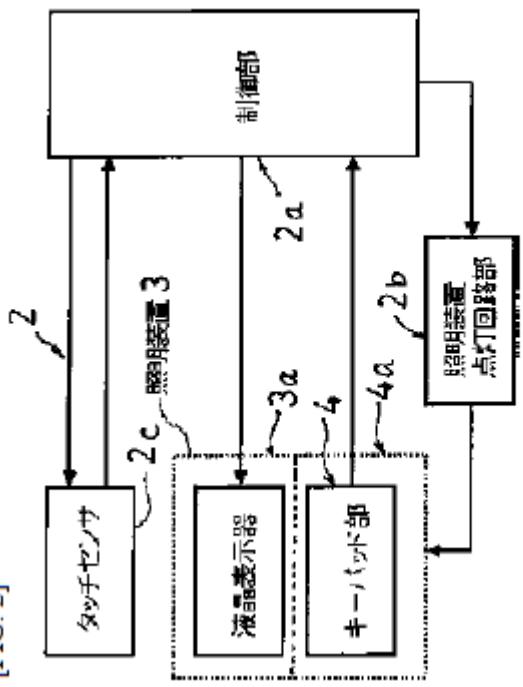

- 2c: Touch Sensor
- 3: Lighting Device
- 3a: Liquid Crystal Display Device
- 4: Keypad Portion
- 2a: Controlling Portion
- 2b: Lighting Device ON/OFF Circuit Portion

Fukiharu 598 at Fig. 2.

“If in the voice communication mode, a touch sensor 2c is placed into an operating state by a signal from the controlling portion 2a, and constantly outputs a detection output to the controlling portion 2a. If the touch sensor 2c contacts a portion of the human body, such as an ear, a lighting-OFF signal is outputted to the lighting device ON/OFF circuit portion 2b from the controlling portion 2a through the ON output of the touch sensor 2c, and the power supplies to both the lighting device (backlight) 3a and the lighting device (backlight) 4a go to the OFF state, and this lighting-OFF state is maintained until the touch sensor 2c goes into a non-contact state. Moreover, when the touch sensor 2c goes from a contact state to a non-contact state, a lighting-ON signal is outputted from the controlling portion 2a to the lighting device ON/OFF circuit portion 2b through the OFF output from the touch sensor 2c, and both the lighting device (backlight) 3a and the lighting device (backlight) 4a go into the ON state, and the lighting-ON state is maintained.” Fukiharu 598 at ¶ 0015.

“A mobile telephone with a lighting device, equipped with a lighting device (backlight) on a liquid crystal display device and/or a keypad portion, comprising: lighting controlling means made from a controlling portion, a lighting device ON/OFF circuit portion, and a touch sensor, wherein: the lighting device (backlight) can be turned ON and OFF by the lighting controlling means.” Fukiharu 598 at Claim 1.

“A mobile telephone with a lighting device as set forth in Claim 1, wherein: a touch sensor that structures the lighting controlling means is activated by the touch sensor contacting a portion of the human body, such as an ear, when listening to the receiver portion.” Fukiharu 598 at Claim 2.

<p>[1f] (c) reduce power to the display if (i) the microprocessor determines that a telephone call is active and (ii) the signal indicates the proximity of the external object; wherein:</p>	<p>Fukiharu 598 discloses the microprocessor adapted to reduce power to the display if (i) the microprocessor determines that a telephone call is active and (ii) the signal indicates the proximity of the external object.</p> <p>For example:</p> <p><i>See</i> discussions of claim elements [1b], [1d], [1e], <i>supra</i>, which are incorporated herein by reference.</p> <p>“Second, a touch sensor that structures the lighting controlling means is activated by the touch sensor contacting a portion of the human body, such as an ear, when listening to the receiver portion. Third, the touch sensor is disposed on the periphery of the receiver of the mobile telephone. Fourth, ON/OFF of the lighting device (backlight) is controlled through a signal that is sent from the controlling portion through a lighting device ON/OFF circuit portion.” Fukiharu 598 at ¶ 0008.</p> <p>“Fifth, a power supply for a mobile telephone is turned ON through pressing of a power supply button of a keypad portion, and, through pressing of a lighting device switch (SW) of a keypad portion, a lighting-ON signal is outputted to a lighting device ON/OFF circuit portion from a controlling portion, to cause the lighting device (backlight) to light, where if not in a voice communication mode, a lighting-ON state is maintained, but if in a voice communication mode, a touch sensor is placed into an operating state by a signal from a controlling portion, and a normal detection output is outputted to the controlling portion and, in addition, if a portion of a human body, such as an ear, makes contact with the touch sensor, a lighting-OFF signal is outputted to the lighting device ON/OFF circuit portion from the controlling portion through an ON output from the touch sensor, to cause the power supply of the lighting device</p>
---	--

(backlight) to go into the OFF state, and the lighting-OFF state is maintained until the touch sensor is no longer contacted.” Fukiharu 598 at ¶ 0009.

“If in the voice communication mode, a touch sensor 2c is placed into an operating state by a signal from the controlling portion 2a, and constantly outputs a detection output to the controlling portion 2a. If the touch sensor 2c contacts a portion of the human body, such as an ear, a lighting-OFF signal is outputted to the lighting device ON/OFF circuit portion 2b from the controlling portion 2a through the ON output of the touch sensor 2c, and the power supplies to both the lighting device (backlight) 3a and the lighting device (backlight) 4a go to the OFF state, and this lighting-OFF state is maintained until the touch sensor 2c goes into a non-contact state. Moreover, when the touch sensor 2c goes from a contact state to a non-contact state, a lighting-ON signal is outputted from the controlling portion 2a to the lighting device ON/OFF circuit portion 2b through the OFF output from the touch sensor 2c, and both the lighting device (backlight) 3a and the lighting device (backlight) 4a go into the ON state, and the lighting-ON state is maintained.” Fukiharu 598 at ¶ 0015.

“Additionally, when the touch sensor 2c is in the noncontact state, if the state changes from the voice communication mode to other than the voice communication mode, the power supply to the touch sensor 2c is cut off, to produce a non-operating state, and the lighting-ON state is maintained.” Fukiharu 598 at ¶ 0016.

“

[FIG. 3]

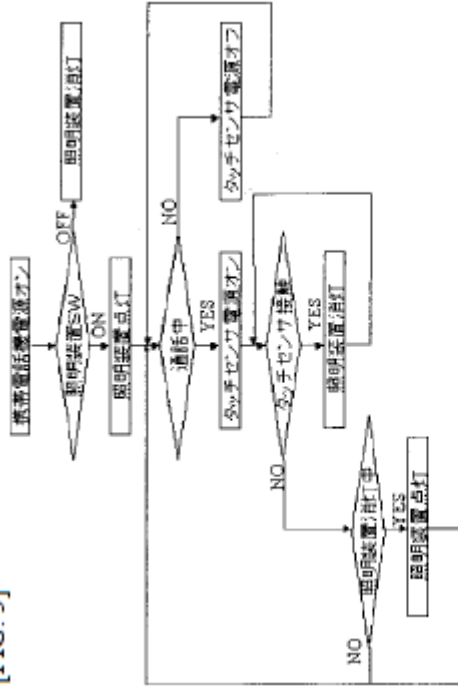

[LOWER LEFT DIAMOND] Lighting device OFF?

[LOWER LEFT RECTANGLE] Turn lighting device ON.

[MIDDLE COLUMN, TOP TO BOTTOM]

Mobile telephone power supply ON

Lighting device SW?

Turn lighting device ON.

Voice communication in process?

Turn touch sensor power supply ON.

Touch sensor contacted?

Turn lighting device OFF.

[UPPER RIGHT] Turn lighting device OFF.

[BOTTOM RIGHT] Turn touch sensor power supply OFF. »

Fukiharu 598 at Fig. 3.

“A mobile telephone with a lighting device, equipped with a lighting device (backlight) on a liquid crystal display device and/or a keypad portion, comprising: lighting controlling means made from a controlling portion, a lighting device ON/OFF circuit

portion, and a touch sensor, wherein: the lighting device (backlight) can be turned ON and OFF by the lighting controlling means.” Fukiharu 598 at Claim 1.

“A mobile telephone with a lighting device as set forth in Claim 1, wherein: a touch sensor that structures the lighting controlling means is activated by the touch sensor contacting a portion of the human body, such as an ear, when listening to the receiver portion.” Fukiharu 598 at Claim 2.

“A mobile telephone with a lighting device as set forth in Claim 1, configured so that: ON/OFF of the lighting device (backlight) is controlled through a signal that is sent from the controlling portion through a lighting device ON/OFF circuit portion.” Fukiharu 598 at Claim 4.

“A lighting controlling method for a mobile telephone wherein: the power supply for the mobile telephone is turned ON through pressing of a power supply button of a keypad portion; and through pressing of a lighting device switch (SW) of a keypad portion, a lighting-ON signal is outputted to a lighting device ON/OFF circuit portion from a controlling portion, to cause the lighting device (backlight) to light, where if not in a voice communication mode, a lighting-ON state is maintained, but if in a voice communication mode, a touch sensor is placed into an operating state by a signal from a controlling portion, and a normal detection output is outputted to the controlling portion and, in addition, if a portion of a human body, such as an ear, makes contact with the touch sensor, a lighting-OFF signal is outputted to the lighting device ON/OFF circuit portion from the controlling portion through an ON output from the touch sensor, to cause the power supply of the lighting device (backlight) to go into the OFF state, and the lighting-OFF state is maintained until the touch sensor is no longer contacted.” Fukiharu 598 at Claim 5.

<p>[1g] the telephone call is a wireless telephone call;</p>	<p>Fukiharu 598 discloses the telephone call as a wireless telephone call.</p> <p>For example:</p> <p><i>See</i> discussion of claim elements 1 [a] and 1 [d], <i>supra</i>, which is incorporated herein by reference.</p> <p>“The present invention relates to a lighting device controlling method for a mobile telephone that is light weight and has good portability, and that achieves a reduction in the consumption of electric power through controlling, through a touch sensor that is provided on a receiver portion section, the activation of a lighting device (backlight) for a liquid crystal display device or keypad portion that is equipped in the mobile telephone.” Fukiharu 598 at ¶ 0001.</p> <p>“As mobile telephones of today, there are those that can be used while moving, whether indoors or outdoors, through the use of radio communication as the communicating means.” Fukiharu 598 at ¶ 0002.</p> <p>“Moreover, the electric power consumed by the lighting device (backlight) for lighting the liquid crystal display device or keypad portion, equipped in the conventional mobile telephone, consumes an extremely large amount of electric power compared to the amount of electric power consumed by the circuitry in the various portions for voice communication. In order to take full advantage of the lighting device (backlight) function, the use of a highcapacity battery is required, which, on the other hand, requires an increase in size in the telephone main unit, which causes problems such as reducing portability.” Fukiharu 598 at ¶ 0004.</p>
--	--

“Because of this, even in conventional mobile telephones, there have been a variety of innovations to minimize the need for the lighting device (backlight). For example, while mobile telephones have been developed of a type wherein, for example, when a lighting device (backlight) is lit through, for example, a prescribed sound (audio), or the like, where a timer that is built into the main unit is started when the lighting is turned ON, and the lighting device (backlight) is turned OFF when a time set for the timer has expired, but in controlling the lighting device (backlight) of this mobile telephone, when voice communication is carried out in a location wherein there is a great amount of noise, the lighting device (backlight) that has been turned OFF by the timer will become lit again, and thus there is a problem in that, for example, this cannot conserve electric power effectively.” Fukiharu 598 at ¶0005.

“FIG. 1 is an external view of a mobile telephone with a touch sensor, depicting an embodiment according to the present invention . . .” Fukiharu 598 at ¶0011.

“

[FIG. 1]

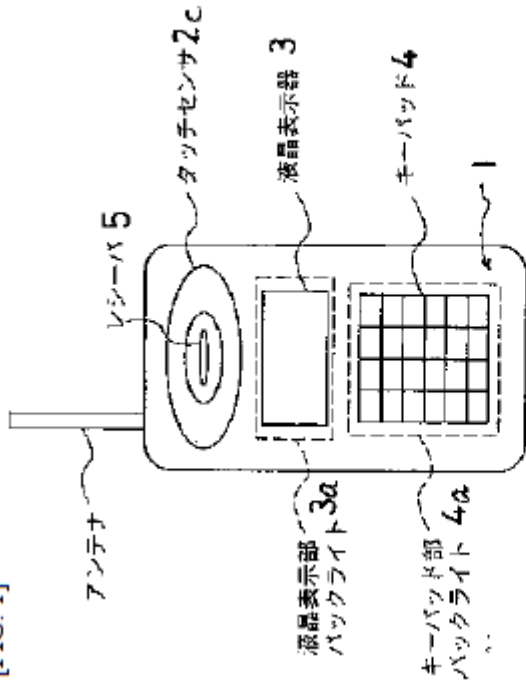

タッチセンサ付き携帯電話機の外観図

[UPPER LEFT] Antenna

5: Receiver

2c: Touch Sensor

3: Liquid Crystal Display Device

4: Keypad

4a: Keypad Portion Backlight

3a: Liquid Crystal Display Portion Backlight

[BOTTOM] Exterior View of Mobile Telephone with Touch Sensor

”

Fukiharu 598 at Fig. 1.

[1h] the microprocessor reduces power to the display while the signal indicates the proximity of the external object only if the microprocessor determines that the wireless telephone call is active; and

Fukiharu 598 discloses that the microprocessor reduces power to the display while the signal indicates the proximity of the external object only if the microprocessor determines that the wireless telephone call is active.

For example:

See discussion of claim element [1f], *supra*, which is incorporated herein by reference.

“Fifth, a power supply for a mobile telephone is turned ON through pressing of a power supply button of a keypad portion, and, through pressing of a lighting device switch (SW) of a keypad portion, a lighting-ON signal is outputted to a lighting device ON/OFF circuit portion from a controlling portion, to cause the lighting device (backlight) to light, where if not in a voice communication mode, a lighting-ON state is maintained, but if in a voice communication mode, a touch sensor is placed into an operating state by a signal from a controlling portion, and a normal detection output is outputted to the controlling portion and, in addition, if a portion of a human body, such as an ear, makes contact with the touch sensor, a lighting-OFF signal is outputted to the lighting device ON/OFF circuit portion from the controlling portion through an ON output from the touch sensor, to cause the power supply of the lighting device (backlight) to go into the OFF state, and the lighting-OFF state is maintained until the touch sensor is no longer contacted.” Fukiharu 598 at ¶ 0009.

“If in the voice communication mode, a touch sensor 2c is placed into an operating state by a signal from the controlling portion 2a, and constantly outputs a detection output to the controlling portion 2a. If the touch sensor 2c contacts a portion of the human body, such as an ear, a lighting-OFF signal is outputted to the lighting device ON/OFF circuit portion 2b from the controlling portion 2a through the ON output of the touch sensor 2c, and the power supplies to both the lighting device (backlight) 3a and the lighting device (backlight) 4a go to the OFF state, and this lighting-OFF state is maintained until the touch sensor 2c goes into a non-contact state. Moreover, when the touch sensor 2c goes from a contact state to a non-contact state, a lighting-ON signal is outputted from the controlling portion 2a to the lighting device ON/OFF circuit portion 2b through the OFF output from the touch sensor 2c, and both the lighting

device (backlight) 3a and the lighting device (backlight) 4a go into the ON state, and the lighting-ON state is maintained.” Fukiharu 598 at ¶ 0015.

“Additionally, when the touch sensor 2c is in the noncontact state, if the state changes from the voice communication mode to other than the voice communication mode, the power supply to the touch sensor 2c is cut off, to produce a non-operating state, and the lighting-ON state is maintained.” Fukiharu 598 at ¶ 0016.

“

[FIG. 3]

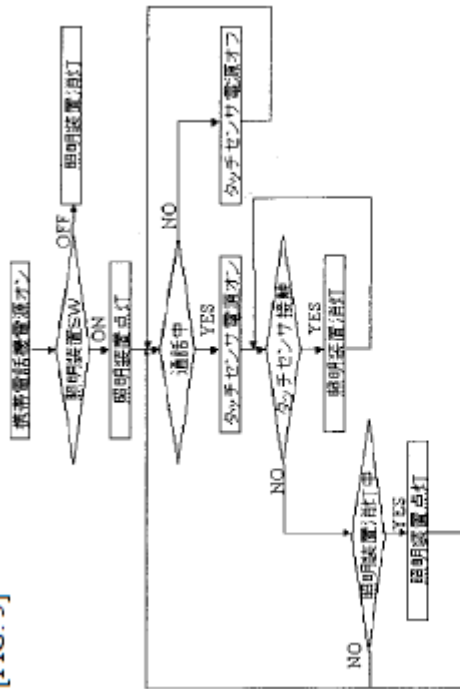

[LOWER LEFT DIAMOND] Lighting device OFF?

[LOWER LEFT RECTANGLE] Turn lighting device ON.

[MIDDLE COLUMN, TOP TO BOTTOM]

Mobile telephone power supply ON

Lighting device SW?

Turn lighting device ON.

Voice communication in process?

Turn touch sensor power supply ON.

Touch sensor contacted?

Turn lighting device OFF.

[UPPER RIGHT] Turn lighting device OFF.

[BOTTOM RIGHT] Turn touch sensor power supply OFF.

Fukiharu 598 at Fig. 3.

“A lighting controlling method for a mobile telephone wherein: the power supply for the mobile telephone is turned ON through pressing of a power supply button of a keypad portion; and through pressing of a lighting device switch (SW) of a keypad portion, a lighting-ON signal is outputted to a lighting device ON/OFF circuit portion

	<p>from a controlling portion, to cause the lighting device (backlight) to light, where if not in a voice communication mode, a lighting-ON state is maintained, but if in a voice communication mode, a touch sensor is placed into an operating state by a signal from a controlling portion, and a normal detection output is outputted to the controlling portion and, in addition, if a portion of a human body, such as an ear, makes contact with the touch sensor, a lighting-OFF signal is outputted to the lighting device ON/OFF circuit portion from the controlling portion through an ON output from the touch sensor, to cause the power supply of the lighting device (backlight) to go into the OFF state, and the lighting-OFF state is maintained until the touch sensor is no longer contacted.” Fukiharu 598 at Claim 5.</p>
<p>[11] the proximity sensor begins detecting whether an external object is proximate substantially concurrently with the mobile station initiating an outgoing wireless telephone call or receiving an incoming wireless telephone call.</p>	<p>Fukiharu 598 discloses that the proximity sensor begins detecting whether an external object is proximate substantially concurrently with the mobile station initiating an outgoing wireless telephone call or receiving an incoming wireless telephone call.</p> <p>For example:</p> <p><i>See</i> discussion of claim element [1f], <i>supra</i>, which is incorporated herein by reference.</p> <p>“If in the voice communication mode, a touch sensor 2c is placed into an operating state by a signal from the controlling portion 2a, and constantly outputs a detection output to the controlling portion 2a.” Fukiharu 598 at ¶ 0015.</p> <p>“</p>

[FIG. 3]

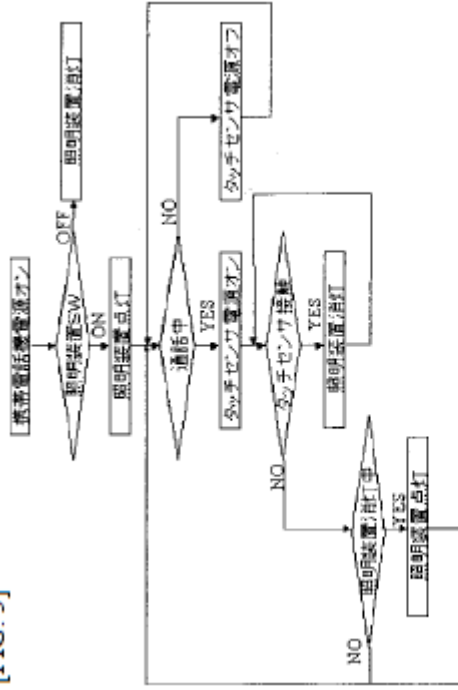

[LOWER LEFT DIAMOND] Lighting device OFF?
 [LOWER LEFT RECTANGLE] Turn lighting device ON.
 [MIDDLE COLUMN, TOP TO BOTTOM]
 Mobile telephone power supply ON
 Lighting device SW?
 Turn lighting device ON.
 Voice communication in process?
 Turn touch sensor power supply ON.
 Touch sensor contacted?
 Turn lighting device OFF.
 [UPPER RIGHT] Turn lighting device OFF.
 [BOTTOM RIGHT] Turn touch sensor power supply OFF. »

Fukiharu 598 at Fig. 3.

To the extent Fukiharu 598 is deemed to not expressly disclose “the proximity sensor begins detecting whether an external object is proximate substantially concurrently with the mobile station initiating an outgoing wireless telephone call or receiving an incoming wireless telephone call,” Fukiharu 598 inherently discloses this limitation. In

Fukiharu 598, “[i]f in the voice communication mode, a touch sensor 2c is placed into an operating state by a signal from the controlling portion 2a, and constantly outputs a detection output to the controlling portion 2a.” ¶ 0015. A person of ordinary skill in the art at the time of the alleged invention would understand that this occurs “substantially concurrently with the mobile station initiating an outgoing wireless telephone call or receiving an incoming wireless telephone call.” A person of ordinary skill in the art at the time of the alleged invention would understand that “initiating an outgoing wireless telephone call or receiving an incoming wireless telephone call” places a mobile telephone in voice communication mode, and Fukiharu 598 does not suggest any delay from entering voice communication mode to placing touch sensor 2c “into an operating state” in which it “constantly outputs a detection output.” Thus, a person of ordinary skill in the art at the time of the alleged invention would understand Fukiharu 598 to inherently disclose that “the proximity sensor begins detecting whether an external object is proximate substantially concurrently with the mobile station initiating an outgoing wireless telephone call or receiving an incoming wireless telephone call.”

To the extent Fukiharu 598 is deemed to not expressly or inherently disclose “the proximity sensor begins detecting whether an external object is proximate substantially concurrently with the mobile station initiating an outgoing wireless telephone call or receiving an incoming wireless telephone call,” Fukiharu 598 renders it obvious to one of skill in the art to have “the proximity sensor begin[] detecting whether an external object is proximate substantially concurrently with the mobile station initiating an outgoing wireless telephone call or receiving an incoming wireless telephone call.” A person of ordinary skill in the art at the time of the alleged invention would understand that “initiating an outgoing wireless telephone call or receiving an incoming wireless telephone call” places a mobile telephone in voice communication mode, and Fukiharu 598 does not suggest any delay from entering voice communication mode to placing touch sensor 2c “into an operating state” in which it “constantly outputs a detection output.” Thus, it would be obvious to a person of ordinary skill in the art at the time of the alleged invention to have “the proximity sensor begin[] detecting whether an

	external object is proximate substantially concurrently with the mobile station initiating an outgoing wireless telephone call or receiving an incoming wireless telephone call.”
[Claim 2] The mobile station of claim 1, wherein the microprocessor reduces power to the display only if (i) the microprocessor determines that a telephone call is active and (ii) the signal indicates the proximity of the external object.	<p>Fukiharu 598 discloses the microprocessor reducing power to the display only if (i) the microprocessor determines that a telephone call is active and (ii) the signal indicates the proximity of the external object.</p> <p>For example:</p> <p><i>See</i> discussion of claim element [1h], <i>supra</i>, which is incorporated herein by reference.</p>
[Claim 4] The mobile station as recited in claim 1, wherein the microprocessor reduces power to the display by turning off the display.	<p>Fukiharu 598 discloses the microprocessor reducing power to the display by turning off the display.</p> <p>For example:</p> <p>“If the touch sensor 2c contacts a portion of the human body, such as an ear, a lighting-OFF signal is outputted to the lighting device ON/OFF circuit portion 2b from the controlling portion 2a through the ON output of the touch sensor 2c, and the power supplies to both the lighting device (backlight) 3a and the lighting device (backlight) 4a go to the OFF state, and this lighting-OFF state is maintained until the touch sensor 2c goes into a non-contact state.” Fukiharu 598 at ¶ 0015.</p> <p>“</p>

[FIG. 3]

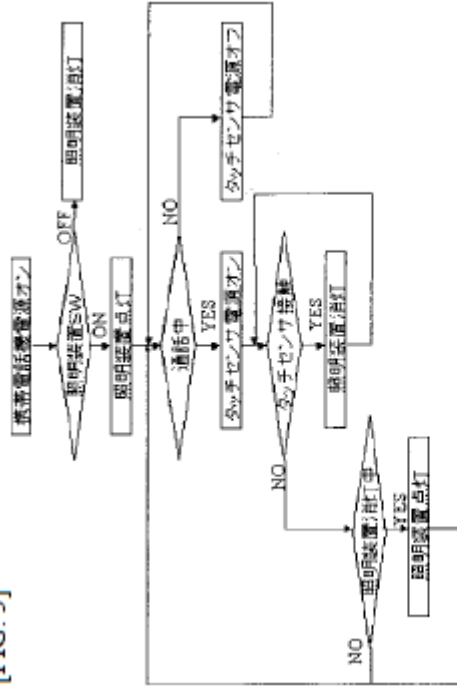

[LOWER LEFT DIAMOND] Lighting device OFF?
 [LOWER LEFT RECTANGLE] Turn lighting device ON.
 [MIDDLE COLUMN, TOP TO BOTTOM]
 Mobile telephone power supply ON
 Lighting device SW?
 Turn lighting device ON.
 Voice communication in process?
 Turn touch sensor power supply ON.
 Touch sensor contacted?
 Turn lighting device OFF.
 [UPPER RIGHT] Turn lighting device OFF.
 [BOTTOM RIGHT] Turn touch sensor power supply OFF. »

Fukiharu 598 at Fig. 3.

[Claim 5] The mobile station as recited in claim 1, wherein the proximity sensor is a mechanical proximity sensor, an optical sensor, or a range-detecting sensor.

Fukiharu 598 discloses that the proximity sensor is a mechanical proximity sensor, an optical sensor, or a range-detecting sensor.

For example:

“FIG. 1 is an external view of a mobile telephone with a touch sensor, depicting an embodiment according to the present invention Fukiharu 598 at ¶ 0011.

[FIG. 1]

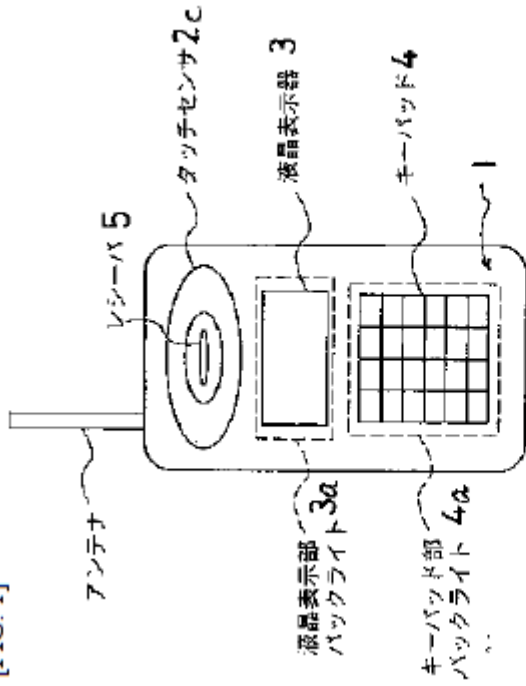

タッチセンサ付き携帯電話機の外観図

[UPPER LEFT] Antenna

5: Receiver

2c: Touch Sensor

3: Liquid Crystal Display Device

4: Keypad

4a: Keypad Portion Backlight

3a: Liquid Crystal Display Portion Backlight

[BOTTOM] Exterior View of Mobile Telephone with Touch Sensor

”

Fukiharu 598 at Fig. 1.

“If the touch sensor 2c contacts a portion of the human body, such as an ear, a lighting-OFF signal is outputted to the lighting device ON/OFF circuit portion 2b from the controlling portion 2a through the ON output of the touch sensor 2c, and the

power supplies to both the lighting device (backlight) 3a and the lighting device (backlight) 4a go to the OFF state, and this lighting-OFF state is maintained until the touch sensor 2c goes into a non-contact state. Moreover, when the touch sensor 2c goes from a contact state to a non-contact state, a lighting-ON signal is outputted from the controlling portion 2a to the lighting device ON/OFF circuit portion 2b through the OFF output from the touch sensor 2c, and both the lighting device (backlight) 3a and the lighting device (backlight) 4a go into the ON state, and the lighting-ON state is maintained.” Fukiharu 598 at ¶ 0015.

To the extent Fukiharu 598 is deemed to not expressly disclose “the proximity sensor is a mechanical proximity sensor, an optical sensor, or a range-detecting sensor,” Fukiharu 598 inherently discloses this limitation. In Fukiharu 598, touch sensor 2c is able to detect contact with a portion of the human body, such as an ear. A person of ordinary skill in the art at the time of the alleged invention would understand that detecting this contact is accomplished by mechanical proximity sensor. Thus, a person of ordinary skill in the art at the time of the alleged invention would understand Fukiharu 598 to inherently disclose “the proximity sensor is a mechanical proximity sensor, an optical sensor, or a range-detecting sensor.”

To the extent Fukiharu 598 is deemed to not expressly or inherently disclose “the proximity sensor is a mechanical proximity sensor, an optical sensor, or a range-detecting sensor,” Fukiharu 598 renders it obvious to one of ordinary skill in the art at the time of the alleged invention to use a mechanical proximity sensor. A person of ordinary skill in the art at the time of the alleged invention would be aware of “conventional mechanical proximity (load) sensors,” which the ’889 Patent identifies as known prior art. *See* ’889 Patent at 3:15-20. A person of ordinary skill in the art at the time of the alleged invention would understand that a mechanical proximity sensor could be used to detect contact with a portion of the human body, such as an ear. Using a mechanical proximity sensor would constitute, at least, combining prior art elements according to known methods to yield predictable results, a simple substitution of one known element for another to obtain predictable results, the use of a known

	<p>technique to improve similar devices in the same way, the application of a known technique to a known device ready for improvement to yield a predictable result, and obvious to try.</p>
<p>[Claim 6] The mobile station as recited in claim 1, wherein the proximity sensor is located proximate to the display.</p>	<p>Fukiharu 598 discloses that the proximity sensor is located proximate to the display.</p> <p>For example:</p> <p>“The object of the present invention is to provide a mobile telephone with a lighting device, and a method for controlling said lighting device, with improved portability through reducing the weight and volume of the battery, and to enable a thorough increase in talk time and standby time, through controlling, through a touch sensor that is provided on a receiver portion surface of the mobile telephone, operation of a lighting device (backlight) of a liquid crystal display device and/or a key pad portion.” Fukiharu 598 at Abstract.</p> <p>“</p>

[FIG. 1]

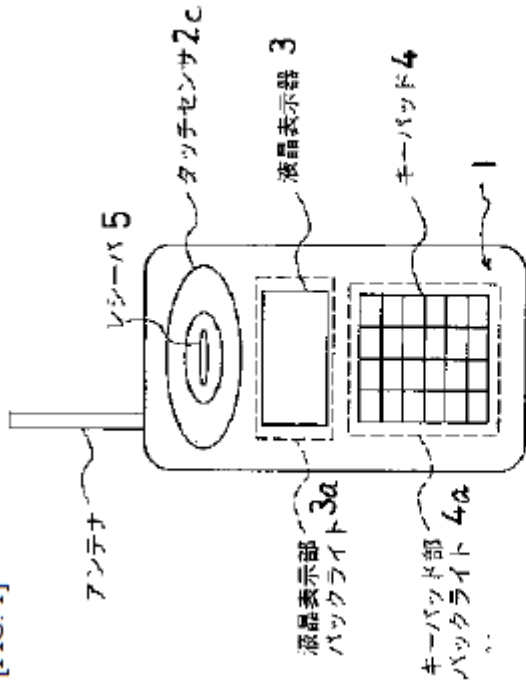

タッチセンサ付き携帯電話機の外観図

[UPPER LEFT] Antenna

5: Receiver

2c: Touch Sensor

3: Liquid Crystal Display Device

4: Keypad

4a: Keypad Portion Backlight

3a: Liquid Crystal Display Portion Backlight

[BOTTOM] Exterior View of Mobile Telephone with Touch Sensor

”

Fukiharu 598 at Fig. 1.

	<p>“A mobile telephone with a lighting device as set forth in Claim 1, wherein: the touch sensor is disposed on the periphery of the receiver of the mobile telephone.” Fukiharu 598 at Claim 3.</p>
<p>[Claim 8 – Preamble] 8. A method of conserving battery power in a mobile station, comprising:</p>	<p>To the extent the preamble is construed as limiting, Fukiharu 598 discloses a method of conserving battery power in a mobile station.</p> <p>For example:</p> <p><i>See</i> discussion of claim elements [1a] and 1[F], <i>supra</i>, which are incorporated herein by reference.</p> <p>“The present invention relates to a lighting device controlling method for a mobile telephone that is light weight and has good portability, and that achieves a reduction in the consumption of electric power through controlling, through a touch sensor that is provided on a receiver portion section, the activation of a lighting device (backlight) for a liquid crystal display device or keypad portion that is equipped in the mobile telephone.” Fukiharu 598 at ¶ 0001.</p> <p>“FIG. 1 is an external view of a mobile telephone with a touch sensor, depicting an embodiment according to the present invention” Fukiharu 598 at ¶ 0011.</p> <p>“</p>

[FIG. 1]

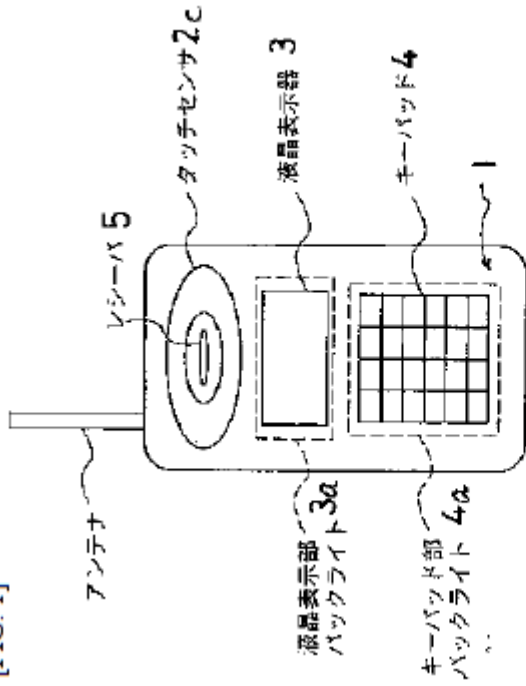

タッチセンサ付き携帯電話機の外観図

[UPPER LEFT] Antenna

5: Receiver

2c: Touch Sensor

3: Liquid Crystal Display Device

4: Keypad

4a: Keypad Portion Backlight

3a: Liquid Crystal Display Portion Backlight

[BOTTOM] Exterior View of Mobile Telephone with Touch Sensor

”

Fukiharu 598 at Fig. 1.

“The present invention, through the use of a structure as described above, enables a reduction in the consumption of battery power, through enabling the lighting devices to be turned OFF when the ear is caused to contact the receiver portion in order to hear the receiver sound during voice communications of a mobile telephone when the

	<p>lighting devices (backlights) for a liquid crystal display device and keypad portion of a mobile telephone are lit, such as that night.” Fukiharu 598 at ¶ 0018.</p> <p>“Moreover, because this can reduce the consumption of electric power of the mobile telephone, this enables an extension in the talk time or the standby time of an individual charging cycle of the battery, and enables a reduction in the volume and weight of the mobile telephone, through achieving miniaturization of the battery.” Fukiharu 598 at ¶ 0019.</p>
<p>[8a] detecting whether an external object is proximate;</p>	<p>Fukiharu 598 discloses detecting whether an external object is proximate.</p> <p>For example:</p> <p><i>See</i> discussion of claim elements [1b] and 1 [e], <i>supra</i>, which are incorporated herein by reference.</p> <p>“If in the voice communication mode, a touch sensor 2c is placed into an operating state by a signal from the controlling portion 2a, and constantly outputs a detection output to the controlling portion 2a. If the touch sensor 2c contacts a portion of the human body, such as an ear, a lighting-OFF signal is outputted to the lighting device ON/OFF circuit portion 2b from the controlling portion 2a through the ON output of the touch sensor 2c, and the power supplies to both the lighting device (backlight) 3a and the lighting device (backlight) 4a go to the OFF state, and this lighting-OFF state is maintained until the touch sensor 2c goes into a non-contact state.” Fukiharu 598 ¶ 0015.</p>

66

[FIG. 3]

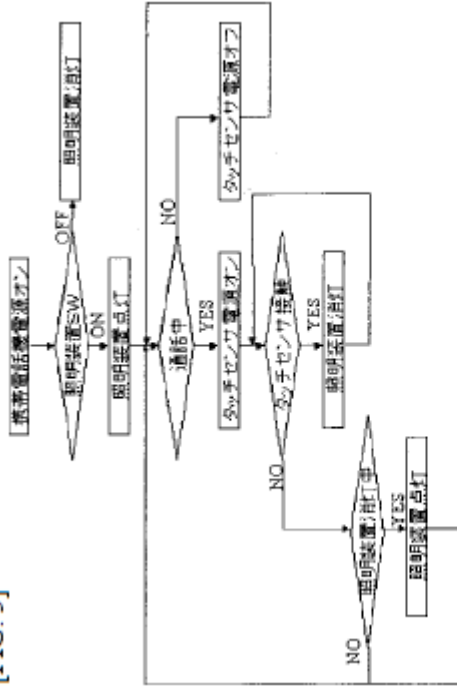

[LOWER LEFT DIAMOND] Lighting device OFF?
 [LOWER LEFT RECTANGLE] Turn lighting device ON.
 [MIDDLE COLUMN, TOP TO BOTTOM]
 Mobile telephone power supply ON
 Lighting device SW?
 Turn lighting device ON.
 Voice communication in process?
 Turn touch sensor power supply ON.
 Touch sensor contacted?
 Turn lighting device OFF.
 [UPPER RIGHT] Turn lighting device OFF.
 [BOTTOM RIGHT] Turn touch sensor power supply OFF. »

Fukiharu 598 at Fig. 3.

[8b] determining whether a telephone call is active; and

Fukiharu 598 discloses determining whether a telephone call is active.

For example:

See discussion of claim element [1d], *supra*, which is incorporated herein by reference.

To the extent Fukiharu 598 is deemed to not expressly disclose this claim limitation, Fukiharu 598 inherently discloses this limitation. *See* discussion of claim element [1d], *supra*, which is incorporated herein by reference.

To the extent Fukiharu 598 is deemed to not expressly or inherently disclose this claim limitation, Fukiharu 598 renders it obvious to one of skill in the art at the time of the alleged invention. *See* discussion of claim element [1d], *supra*, which is incorporated herein by reference.

To the extent Fukiharu 598 is deemed to not expressly or inherently disclose this claim element, it would be obvious to combine the disclosure of Fukiharu 598 with those of Numazawa as described in the Numazawa claim chart, which is incorporated herein in its entirety by reference. *See* discussion of claim element [1d], *supra*, which is incorporated herein by reference.

To the extent Fukiharu 598 is deemed to not expressly or inherently disclose this claim element, it would be obvious to combine the disclosure of Fukiharu 598 with those of Sparre as described in the Sparre claim chart, which is incorporated herein in its entirety by reference. *See* discussion of claim element [1d], *supra*, which is incorporated herein by reference.

To the extent Fukiharu 598 is deemed to not expressly or inherently disclose this claim element, it would be obvious to combine the disclosure of Fukiharu 598 with those of Perez as described in the Perez claim chart, which is incorporated herein in its entirety by reference. *See* discussion of claim element [1d], *supra*, which is incorporated herein by reference.

To the extent Fukiharu 598 is deemed to not expressly or inherently disclose this claim element, it would be obvious to combine the disclosure of Fukiharu 598 with those of

	<p>Mantyarvi as described in the Mantyarvi claim chart, which is incorporated herein in its entirety by reference. <i>See</i> discussion of claim element [1d], <i>supra</i>, which is incorporated herein by reference.</p>
<p>[8c] reducing power consumption of a display of the mobile station if (i) a telephone call is determined to be active and (ii) the proximity of the external object is detected; wherein:</p>	<p>Fukiharu 598 discloses reducing power consumption of a display of the mobile station if (i) a telephone call is determined to be active and (ii) the proximity of the external object is detected.</p> <p>For example:</p> <p><i>See</i> discussion of claim element [1f], <i>supra</i>, which is incorporated herein by reference.</p>
<p>[8d] the telephone call is a wireless telephone call;</p>	<p>Fukiharu 598 discloses that the telephone call is a wireless telephone call.</p> <p>For example:</p> <p><i>See</i> discussion of claim element [1g], <i>supra</i>, which is incorporated herein by reference.</p>
<p>[8e] the power consumption of the display is reduced while the proximity of the external object is detected only if the wireless telephone call is determined to be active; and</p>	<p>Fukiharu 598 discloses that the power consumption of the display is reduced while the proximity of the external object is detected only if the wireless telephone call is determined to be active.</p> <p>For example:</p> <p><i>See</i> discussion of claim element [1h], <i>supra</i>, which is incorporated herein by reference.</p>

<p>[8f] detecting whether an external object is proximate begins substantially concurrently with the mobile station initiating an outgoing wireless telephone call or receiving an incoming wireless telephone call.</p>	<p>Fukiharu 598 discloses that detecting whether an external object is proximate begins substantially concurrently with the mobile station initiating an outgoing wireless telephone call or receiving an incoming wireless telephone call.</p> <p>For example:</p> <p><i>See</i> discussion of claim element [1i], <i>supra</i>, which is incorporated herein by reference.</p> <p>To the extent Fukiharu 598 is deemed to not expressly disclose this claim limitation, Fukiharu 598 inherently discloses this limitation. <i>See</i> discussion of claim element [1i], <i>supra</i>, which is incorporated herein by reference.</p> <p>To the extent Fukiharu 598 is deemed to not expressly or inherently disclose this claim limitation, Fukiharu 598 renders it obvious to one of skill in the art at the time of the alleged invention. <i>See</i> discussion of claim element [1i], <i>supra</i>, which is incorporated herein by reference.</p>
<p>[Claim 12] The method as recited in claim 8, wherein the detecting of the proximity of the external object is performed by a mechanical proximity sensor, an optical sensor, or a range-detecting sensor.</p>	<p>Fukiharu 598 discloses that the detecting of the proximity of the external object is performed by a mechanical proximity sensor, an optical sensor, or a range-detecting sensor.</p> <p>For example:</p> <p><i>See</i> discussion of Claim 5, <i>supra</i>, which is incorporated herein by reference.</p> <p>To the extent Fukiharu 598 is deemed to not expressly disclose this claim limitation, Fukiharu 598 inherently discloses this limitation. <i>See</i> discussion of claim 5, <i>supra</i>, which is incorporated herein by reference.</p>

<p>To the extent Fukiharu 598 is deemed to not expressly or inherently disclose this claim limitation, Fukiharu 598 renders it obvious to one of skill in the art at the time of the alleged invention. <i>See</i> discussion of claim 5, <i>supra</i>, which is incorporated herein by reference.</p>	
--	--

Exhibit A2

**Exhibit #A2-Numazawa
to Defendants' Preliminary Invalidation Contentions**

**Invalidation Chart for U.S. Patent No. 7,319,889
Japanese Unexamined Patent Application Publication No. H11-220432 ("Numazawa")**

Japanese Unexamined Patent Application Publication No. H11-220432 to Numazawa ("Numazawa") was published on August 10, 1999. Numazawa is prior art to the '889 Patent under at least pre-AIA §§ 102(a), 102(b), and 102(c). Numazawa anticipates or renders obvious, alone or in combination with other prior art references, each of the Asserted Claims of the '889 Patent as described in the chart below and in the main invalidity contentions document to which this chart is annexed.

It would have been obvious under 35 U.S.C. § 103 to a person having ordinary skill in the art at the time of the alleged invention to combine the teachings of Numazawa with the following references:

1. Japanese Unexamined Patent Application Publication No. 2000-106598 to Fukiharu ("Fukiharu 598"). Fukiharu 598 qualifies as prior art under at least pre-AIA §§ 102(a), 102(b), and 102(c). Fukiharu 598 was published on April 11, 2000.
2. U.S. Patent No. 5,586,182 to Miyashita ("Miyashita"). Miyashita qualifies as prior art under at least pre-AIA 35 U.S.C. § 102(c). Miyashita was filed on May 1, 1995 and issued on December 17, 1996.
3. U.S. Patent No. 5,010,566 to Seo ("Seo"). Seo qualifies as prior art under at least pre-AIA 35 U.S.C. §§ 102(a), 102(b), and 102(c). Seo was filed on September 7, 1989 and issued on April 23, 1991.
4. US. Patent Application Publication No. 2004/0225904 A1 to Perez et al. ("Perez"). Perez qualifies as prior art under at least pre-AIA § 102(e). Perez was filed on May 6, 2003 and published on November 11, 2004.

<u>Asserted Claims</u>	<u>Corresponding Disclosure in the Prior Art Reference(s)</u>
[Claim 1 – Preamble] 1. A mobile station, comprising:	<p>Numazawa discloses a mobile station.</p> <p>For example:</p> <p>“Reduced Power Consumption Controlling Method in Wireless Terminal.” Numazawa at Title of the Invention.</p>

“FIG. 1 depicts the structure of a wireless terminal in one embodiment according to the present invention, wherein: 1 is a wireless terminal . . .” Numazawa at ¶ 0016.

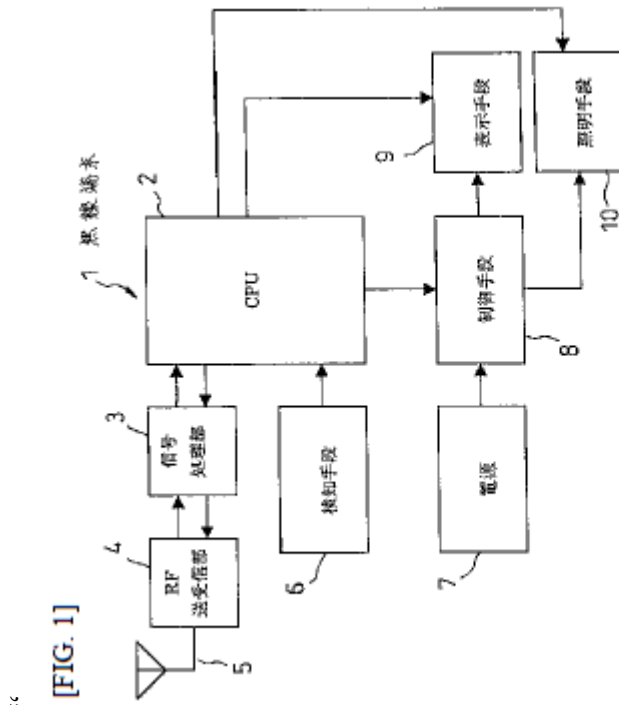

- 4: RF Transceiving Portion
- 3: Signal Processing Portion
- 1: Wireless Terminal
- 6: Detecting Means
- 7: Power Supply
- 8: Controlling Means
- 9: Displaying Means
- 10: Lighting Means

Numazawa at Fig. 1.

“A reduced power consumption controlling method in a wireless terminal, wherein: upon the start of a call, if a function that is unnecessary to the user of the terminal is operating, the operation of the unnecessary function is stopped; and upon termination

<p>[1a] a display;</p>	<p>of the call, the operation of the function that has been stopped is restarted.” Numazawa at Claim 1.</p> <p>Numazawa discloses a display.</p> <p>For example:</p> <p>“Upon identification of contact of the ear to the terminal, controlling means 8 are caused to stop the supply of electric power, from a power supply 7, to displaying means 9 for providing information to a user, and lighting means 10, such as a black light. Even during a call, upon identification that there is a non-contact state between the terminal and the ear, or upon identification, through a signal from a signal processing portion 3, that the call has been terminated, the supply of electric power to the displaying means 9 and the lighting means 10 is restarted.” Numazawa at Abstract.</p> <p>“FIG. 1 depicts the structure of a wireless terminal in one embodiment according to the present invention, wherein: 1 is a wireless terminal; . . . 7 is a power supply for supply electric power to displaying means and lighting means; 8 is controlling means for controlling the displaying means and lighting means depending on the evaluation by the CPU 2; 9 is displaying means for displaying text, the state of the terminal, etc.; and 10 is lighting means, such as a backlight, or the like.” Numazawa at ¶ 0016.</p> <p>“</p>
------------------------	---

[FIG. 1]

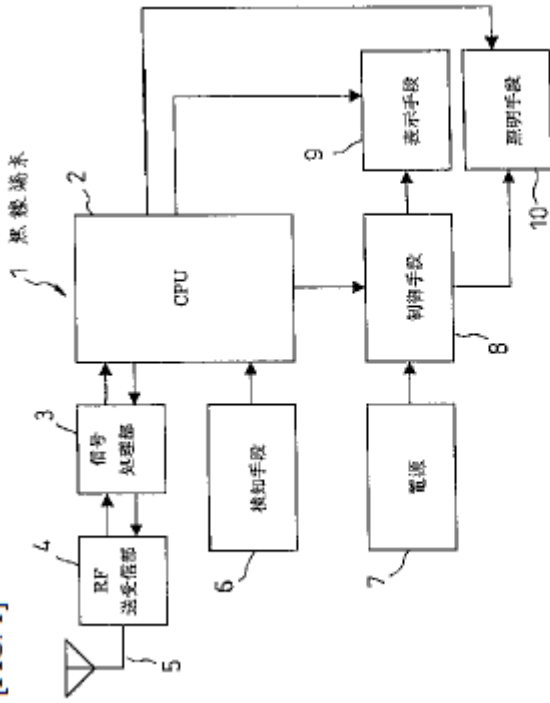

- 4: RF Transceiving Portion
- 3: Signal Processing Portion
- 1: Wireless Terminal
- 6: Detecting Means
- 7: Power Supply
- 8: Controlling Means
- 9: Displaying Means
- 10: Lighting Means

Numazawa at Fig 1.

“A reduced power consumption controlling method in a wireless terminal that has displaying means, wherein: upon the start of a call, if the display on the displaying means becomes unnecessary, the display on the displaying means is stopped, and upon

	<p>termination of the call, the display on the displaying means that has been stopped is restarted.” Numazawa at Claim 2.</p> <p>“A reduced power consumption controlling method as set forth in Claim 2, wherein: if the display on the displaying means is necessary even during a call, the display on the displaying means that had been stopped is restarted.” Numazawa at Claim 3.</p>
<p>[1b] a proximity sensor adapted to generate a signal indicative of proximity of an external object; and</p>	<p>Numazawa discloses a proximity sensor adapted to generate a signal indicative of proximity of an external object.</p> <p>For example:</p> <p>“A CPU 2 identifies start of a call state through a signal from a signal processing portion 3 for controlling communication with a base station, and identifies, through an output signal from detecting means 6, whether or not a user ear is in contact with a terminal. Upon identification of contact of the ear to the terminal, controlling means 8 are caused to stop the supply of electric power, from a power supply 7, to displaying means 9 for providing information to a user, and lighting means 10, such as a black light. Even during a call, upon identification that there is a non-contact state between the terminal and the ear, or upon identification, through a signal from a signal processing portion 3, that the call has been terminated, the supply of electric power to the displaying means 9 and the lighting means 10 is restarted.” Numazawa at Abstract.</p> <p>“In the invention set forth in Claim 6, during a call, whether operation of a function is necessary or not is evaluated through whether or not the receiver is in contact with the ear of the user, and thus there is the effect of being able to start operation of a function immediately when it becomes necessary to start the operation of a function that has</p>

been stopped, when the receiver is removed from the ear of the user, even when in a call state.” Numazawa at ¶ 0014.

“FIG. 1 depicts the structure of a wireless terminal in one embodiment according to the present invention, wherein: 1 is a wireless terminal; 2 is a CPU for evaluating whether or not the wireless terminal is in a call state, whether or not the user has the receiver against his/her ear, etc., and for controlling switching means for starting and stopping the supply of power to the functional block; . . . 6 is detecting means for detecting whether or not the user of the terminal has contacted his/her ear to the terminal; . . .” Numazawa at ¶ 0016.

“When the CPU 2 identifies, through an input signal from the signal processing portion 3, that the call mode has been started, it evaluates, through an input signal from the detecting means 6, whether or not the user has brought the terminal into contact with his or her ear.” Numazawa at ¶ 0017.

“Note that even when, in the CPU 2, the call state has been identified, upon detection, by the detecting means 6, that the user of the terminal has removed the terminal from the ear, the CPU 2 outputs, to the controlling means 8, a signal to start the supply of power from the power supply 7, to thereby start operation of the displaying means 9 and the lighting means 10.” Numazawa at ¶ 0018.

“In Step S3, the output signal from the detecting means 6 is monitored in order to detect whether the user of the wireless terminal has brought the terminal to the ear in the attitude of a call. In this case, when it has been identified, from the output signal from the detecting means 6, that the terminal is in contact with the ear of the user, processing advances to Step S4. Moreover, if it is identified, from the output signal

from the detecting means 6, that the terminal is not in contact with the ear of the user, Step S3 is repeated.” Numazawa at ¶ 0020.

“Next, referencing FIG. 3, in Step S6 the CPU 2 monitors the output signal from the detecting means 6 in order to detect whether or not a call is in progress and the user has the terminal in the attitude of a call. When, in this case, it is identified, from the output signal from the detecting means 6, that the terminal has been separated from the ear of the user, processing advances to Step S7. If the CPU 2 identifies, from the output signal from the detecting means 6, that the terminal is still in contact with the ear of the user, processing advances to Step S11.” Numazawa at ¶ 0022.

“Following this, in Step S8, the CPU 2 monitors the output signal from the detecting means 6 to detect whether or not the user of the terminal has again gone into the attitude of a call. In this case, when the CPU 2 identifies, from the output signal from the detecting means 6, that the terminal is in contact with the ear of the user, processing advances to Step S9. Moreover, if it is identified, from the output signal from the detecting means 6, that the terminal is not in contact with the ear of the user, processing advances to Step S10.” Numazawa at ¶ 0024.

“

[FIG. 1]

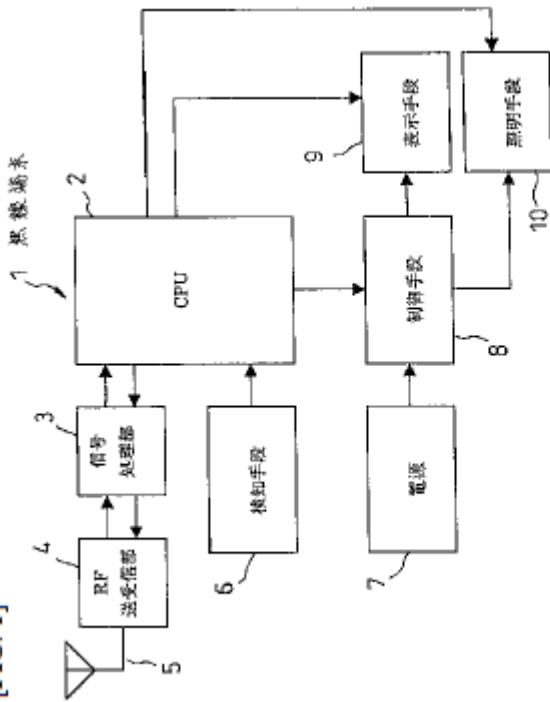

- 4: RF Transceiving Portion
- 3: Signal Processing Portion
- 1: Wireless Terminal
- 6: Detecting Means
- 7: Power Supply
- 8: Controlling Means
- 9: Displaying Means
- 10: Lighting Means

Numazawa at Fig 1.

“

FIG. 2

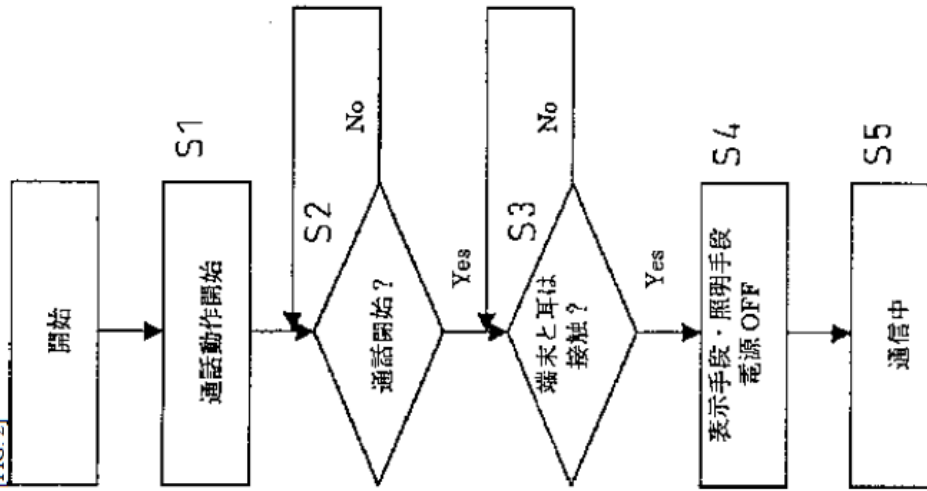

[TOP] Start
S1: Begin Call Operation
S2: Call started?
S3: Terminal and ear in contact?
S4: Turn displaying means/lighting means power supply off.
S5: In Call

Numazawa at Fig 2.

“

[FIG. 3]

S6: Terminal and ear out of contact?
 S7: Turn displaying means/lighting means power supply ON.
 S8: Terminal and ear in contact?
 S9: Turn displaying means/lighting means power supply OFF.
 S10: Call terminated?
 [BOTTOM LEFT] End
 S11: Call terminated?
 S12: Turn displaying means/lighting means power supply ON.

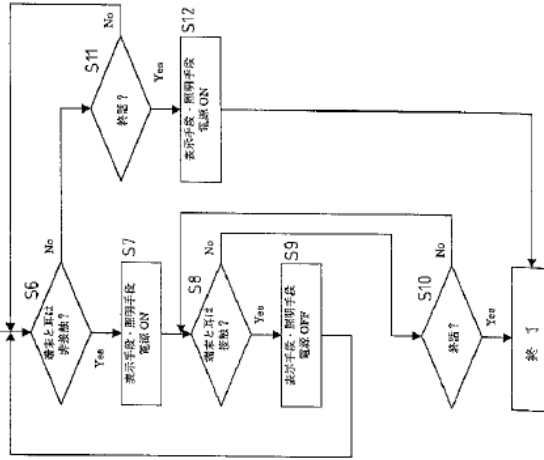

”

Numazawa at Fig 3.

“A reduced power consumption controlling method for a wireless terminal as set forth in any of Claim 1 through 5, wherein: during a call, whether the operation of functions such as displaying means, lighting means, or the like, of a wireless terminal should be stopped or caused to operate is evaluated through detecting contact or non-contact between a receiver and an ear of a user.” Numazawa at Claim 6.

[1c] a microprocessor adapted to:

Numazawa discloses a microprocessor.

For example:

“A CPU 2 identifies start of a call state through a signal from a signal processing portion 3 for controlling communication with a base station, and identifies, through an output signal from detecting means 6, whether or not a user ear is in contact with a terminal.” Numazawa at Abstract.

“FIG. 1 depicts the structure of a wireless terminal in one embodiment according to the present invention, wherein: 1 is a wireless terminal; 2 is a CPU for evaluating whether or not the wireless terminal is in a call state, whether or not the user has the receiver against his/her ear, etc., and for controlling switching means for starting and stopping the supply of power to the functional block” Numazawa at ¶ 0016.

“A summary of the operation of the wireless terminal 1 that uses the method for controlling electric power consumption according to the present invention will be explained next. When the CPU 2 identifies, through an input signal from the signal processing portion 3, that the call mode has been started, it evaluates, through an input signal from the detecting means 6, whether or not the user has brought the terminal into contact with his or her ear. Upon determination that the user of the terminal has brought the terminal into contact with the ear, the CPU 2 causes the controlling means 8 to stop the supply of power from the power supply 7, to stop operation of the displaying means 9 and the lighting means 10. Moreover, upon identification that the call has been terminated, through an input signal from the signal processing portion 3, the CPU 2 outputs, to the controlling means 8, a signal that starts the supply of power from the power supply 7, starting operation of the displaying means 9 and the lighting means 10.” Numazawa at ¶ 0017.

“Note that even when, in the CPU 2, the call state has been identified, upon detection, by the detecting means 6, that the user of the terminal has removed the terminal from the ear, the CPU 2 outputs, to the controlling means 8, a signal to start the supply of power from the power supply 7, to thereby start operation of the displaying means 9 and the lighting means 10.” Numazawa at ¶ 0018.

“The method for controlling conservation of electric power will be explained in detail next, referencing the flowcharts of FIG. 2 and FIG. 3. First, in Step S1 of FIG. 2, an operation is started, through either an outgoing call or incoming call operation, to start a call. Next, in Step S2, in order to evaluate whether or not a call has been started, the CPU 2 monitors the output signal from the signal processing portion 3. If here the CPU 2 identifies, from the output signal from the signal processing portion 3, that a call has been a started, processing advances to Step S3. If the CPU 2 identifies, from the output signal from the signal processing portion 3, that no call has been started, Step S2 is repeated.” Numazawa at ¶ 0019.

“

[FIG. 1]

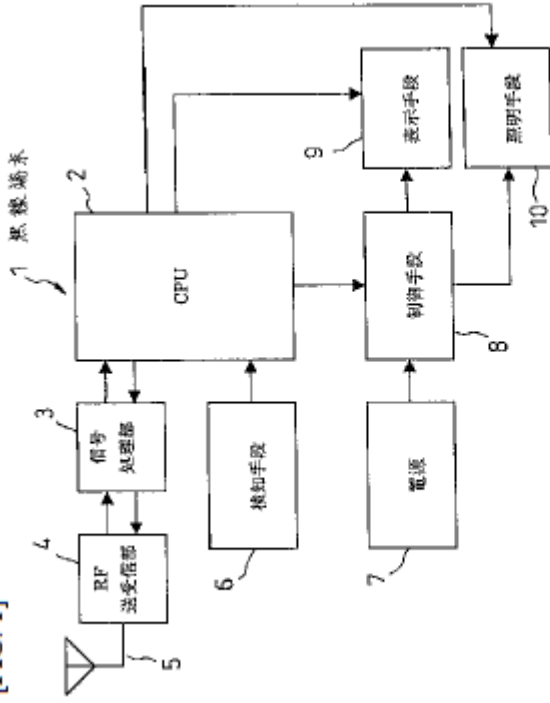

- 4: RF Transceiving Portion
- 3: Signal Processing Portion
- 1: Wireless Terminal
- 6: Detecting Means
- 7: Power Supply
- 8: Controlling Means
- 9: Displaying Means
- 10: Lighting Means

Numazawa at Fig 1.

[1d] (a) determine whether a telephone call is active;

Numazawa discloses the microprocessor adapted to determine whether a telephone call is active.

For example:

“A CPU 2 identifies start of a call state through a signal from a signal processing portion 3 for controlling communication with a base station, and identifies, through an output signal from detecting means 6, whether or not a user ear is in contact with a terminal.” Numazawa at Abstract.

“FIG. 1 depicts the structure of a wireless terminal in one embodiment according to the present invention, wherein: 1 is a wireless terminal; 2 is a CPU for evaluating whether or not the wireless terminal is in a call state, whether or not the user has the receiver against his/her ear, etc., and for controlling switching means for starting and stopping the supply of power to the functional block” Numazawa at ¶ 0016.

“When the CPU 2 identifies, through an input signal from the signal processing portion 3, that the call mode has been started, it evaluates, through an input signal from the detecting means 6, whether or not the user has brought the terminal into contact with his or her ear.” Numazawa at ¶ 0017.

“Note that even when, in the CPU 2, the call state has been identified, upon detection, by the detecting means 6, that the user of the terminal has removed the terminal from the ear, the CPU 2 outputs, to the controlling means 8, a signal to start the supply of power from the power supply 7, to thereby start operation of the displaying means 9 and the lighting means 10.” Numazawa at ¶ 0018.

“Next, in Step S2, in order to evaluate whether or not a call has been started, the CPU 2 monitors the output signal from the signal processing portion 3. If here the CPU 2 identifies, from the output signal from the signal processing portion 3, that a call has been a started, processing advances to Step S3. If the CPU 2 identifies, from the output

signal from the signal processing portion 3, that no call has been started, Step S2 is repeated.” Numazawa at ¶ 0019.

“Following this, in Step S10, the CPU 2 monitors the output signal from the signal processing portion 3 to detect whether or not the wireless terminal has gone into the call terminating state. When, in this case, the CPU 2 identifies, from the output signal from the signal processing portion 3, that the call has been terminated, the displaying means 9 and the lighting means 10 are already operating, so the procedure is terminated, without performing any processing. If it is identified, from the output signal from the signal processing portion 3, that the call has not been terminated, processing returns to Step S8.” Numazawa at ¶ 0026.

“Following this, in Step S11, the CPU 2 monitors the output signal from the signal processing portion 3 to detect whether or not the wireless terminal has gone into the call terminating state. Next, in Step S11, the CPU 2 monitors the output signal from the signal processing portion to detect whether or not the wireless terminal has gone into a call-terminated state. At this time, if the CPU 2 identifies, from the output signal from the signal processing portion 3, that the call has been terminated, processing advances to Step S12. If it is identified, from the output signal from the signal processing portion 3, that the call has not been terminated, processing returns to Step S6.” Numazawa at ¶ 0027.

“

[FIG. 1]

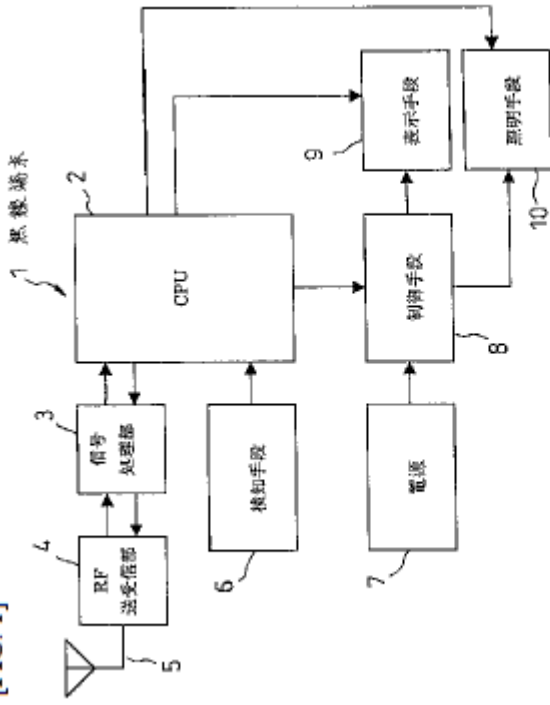

- 4: RF Transceiving Portion
- 3: Signal Processing Portion
- 1: Wireless Terminal
- 6: Detecting Means
- 7: Power Supply
- 8: Controlling Means
- 9: Displaying Means
- 10: Lighting Means

Numazawa at Fig 1.

“

FIG. 2

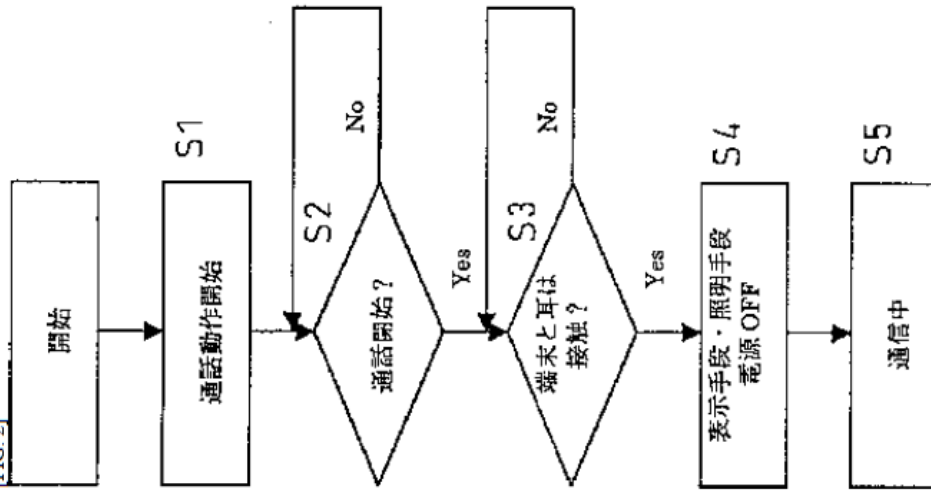

[TOP] Start
S1: Begin Call Operation
S2: Call started?
S3: Terminal and ear in contact?
S4: Turn displaying means/lighting means power supply off.
S5: In Call

Numazawa at Fig 2.

“

[FIG. 3]

- S6: Terminal and ear out of contact?
- S7: Turn displaying means/lighting means power supply ON.
- S8: Terminal and ear in contact?
- S9: Turn displaying means/lighting means power supply OFF.
- S10: Call terminated?
- [BOTTOM LEFT] End
- S11: Call terminated?
- S12: Turn displaying means/lighting means power supply ON.

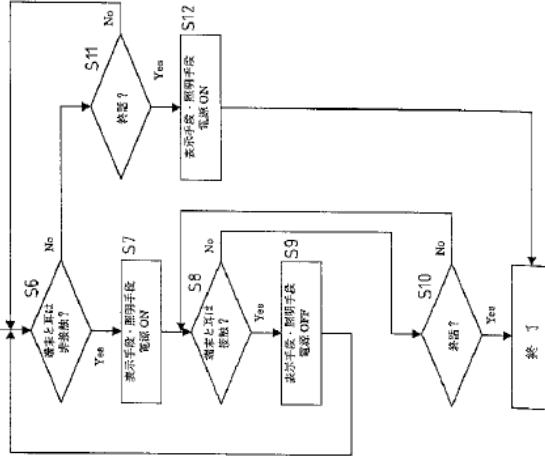

”

Numazawa at Fig 3.

“A reduced power consumption controlling method in a wireless terminal, wherein: upon the start of a call, if a function that is unnecessary to the user of the terminal is operating, the operation of the unnecessary function is stopped; and upon termination of the call, the operation of the function that has been stopped is restarted.”

Numazawa at Claim 1.

“A reduced power consumption controlling method in a wireless terminal that has displaying means, wherein: upon the start of a call, if the display on the displaying means becomes unnecessary, the display on the displaying means is stopped, and upon termination of the call, the display on the displaying means that has been stopped is restarted.” Numazawa at Claim 2.

“A reduced power consumption controlling method as set forth in Claim 2, wherein: if the display on the displaying means is necessary even during a call, the display on the displaying means that had been stopped is restarted.” Numazawa at Claim 3.

“A reduced power consumption controlling method in a wireless terminal that has lighting means, wherein: upon the start of a call, if the illumination of the lighting means becomes unnecessary, the illumination of the lighting means is stopped, and upon termination of the call, the illumination the lighting means that has been stopped is restarted. Numazawa at Claim 4.

“A reduced power consumption controlling method as set forth in Claim 4, wherein: if the illumination of the lighting means is necessary even during a call, the illumination of the lighting means that had been stopped is restarted.” Numazawa at Claim 5.

“A reduced power consumption controlling method for a wireless terminal as set forth in any of Claim 1 through 5, wherein: during a call, whether the operation of functions such as displaying means, lighting means, or the like, of a wireless terminal should be

	<p>stopped or caused to operate is evaluated through detecting contact or non-contact between a receiver and an ear of a user.” Numazawa at Claim 6.</p> <p>To the extent Numazawa is deemed to not expressly disclose the microprocessor adapted to “determine whether a telephone call is active,” Numazawa inherently discloses this limitation. In Numazawa, the CPU 2 identifies the start of a call state through a signal from a signal processing portion 3. A person of skill in the art would understand that identifying the start of a call state necessarily includes determining whether a telephone call is active.</p> <p>To the extent Numazawa is deemed to not expressly or inherently disclose a microprocessor adapted to “determine whether a telephone call is active,” Numazawa renders it obvious to one of skill in the art to use a microprocessor adapted to “determine whether a telephone call is active.” A person of ordinary skill in the art would understand that identifying the start of a call state includes determining whether a telephone call is active. Thus, it would be obvious to a person of skill in the art for signal processing portion 3 to identify this to CPU 2, and the CPU would, therefore, “determine whether a telephone call is active.”</p>
<p>[1e] (b) receive the signal from the proximity sensor; and</p>	<p>Numazawa discloses the microprocessor adapted to receive the signal from the proximity sensor.</p> <p>For example:</p> <p><i>See</i> discussion of claim element [1b], <i>supra</i>, which is incorporated herein by reference.</p> <p>“When the CPU 2 identifies, through an input signal from the signal processing portion 3, that the call mode has been started, it evaluates, through an input signal from the detecting means 6, whether or not the user has brought the terminal into contact with his or her ear.” Numazawa at ¶ 0017.</p>

“In Step S3, the output signal from the detecting means 6 is monitored in order to detect whether the user of the wireless terminal has brought the terminal to the ear in the attitude of a call. In this case, when it has been identified, from the output signal from the detecting means 6, that the terminal is in contact with the ear of the user, processing advances to Step S4. Moreover, if it is identified, from the output signal from the detecting means 6, that the terminal is not in contact with the ear of the user, Step S3 is repeated.” Numazawa at ¶ 0020.

“Next, referencing FIG. 3, in Step S6 the CPU 2 monitors the output signal from the detecting means 6 in order to detect whether or not a call is in progress and the user has the terminal in the attitude of a call. When, in this case, it is identified, from the output signal from the detecting means 6, that the terminal has been separated from the ear of the user, processing advances to Step S7. If the CPU 2 identifies, from the output signal from the detecting means 6, that the terminal is still in contact with the ear of the user, processing advances to Step S11.” Numazawa at ¶ 0022.

“Following this, in Step S8, the CPU 2 monitors the output signal from the detecting means 6 to detect whether or not the user of the terminal has again gone into the attitude of a call. In this case, when the CPU 2 identifies, from the output signal from the detecting means 6, that the terminal is in contact with the ear of the user, processing advances to Step S9. Moreover, if it is identified, from the output signal from the detecting means 6, that the terminal is not in contact with the ear of the user, processing advances to Step S10.” Numazawa at ¶ 0024.

“

[FIG. 1]

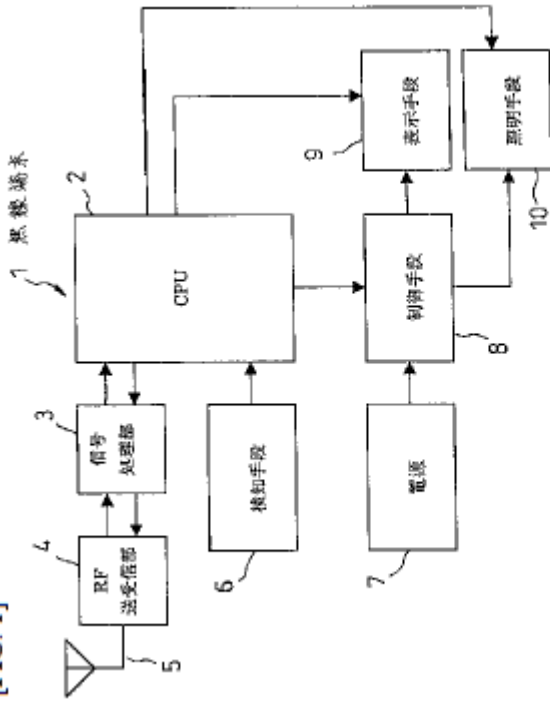

- 4: RF Transceiving Portion
- 3: Signal Processing Portion
- 1: Wireless Terminal
- 6: Detecting Means
- 7: Power Supply
- 8: Controlling Means
- 9: Displaying Means
- 10: Lighting Means

Numazawa at Fig 1.

"

FIG. 2

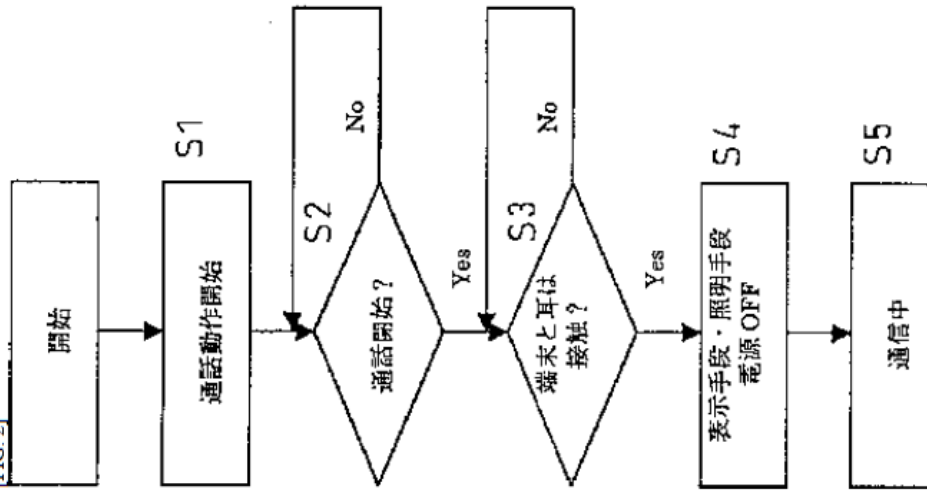

[TOP] Start
S1: Begin Call Operation
S2: Call started?
S3: Terminal and ear in contact?
S4: Turn displaying means/lighting means power supply off.
S5: In Call

Numazawa at Fig 2.

“

[FIG. 3]

S6: Terminal and ear out of contact?
 S7: Turn displaying means/lighting means power supply ON.
 S8: Terminal and ear in contact?
 S9: Turn displaying means/lighting means power supply OFF.
 S10: Call terminated?
 [BOTTOM LEFT] End
 S11: Call terminated?
 S12: Turn displaying means/lighting means power supply ON.

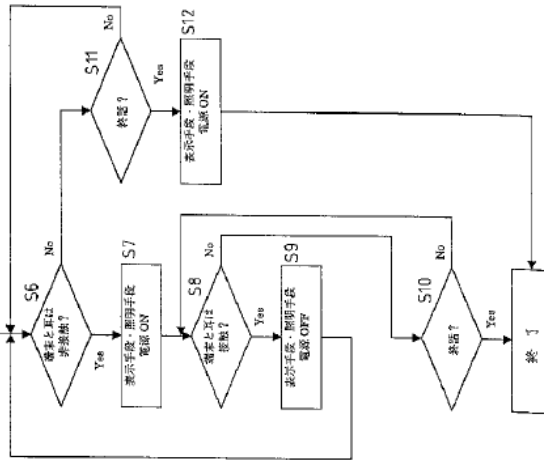

”

Numazawa at Fig 3.

[11f] (c) reduce power to the display if (i) the microprocessor determines that a telephone call is active and (ii) the signal indicates the proximity of the external object; wherein:

Numazawa discloses the microprocessor adapted to reduce power to the display if (i) the microprocessor determines that a telephone call is active and (ii) the signal indicates the proximity of the external object.

For example:

See discussions of claim elements [1b], [1d], [1e], *supra*, which are incorporated herein by reference.

“In the invention set forth in Claim 6, during a call, whether operation of a function is necessary or not is evaluated through whether or not the receiver is in contact with the ear of the user, and thus there is the effect of being able to start operation of a function immediately when it becomes necessary to start the operation of a function that has been stopped, when the receiver is removed from the ear of the user, even when in a call state.” Numazawa at ¶ 0014.

“A summary of the operation of the wireless terminal 1 that uses the method for controlling electric power consumption according to the present invention will be explained next. When the CPU 2 identifies, through an input signal from the signal processing portion 3, that the call mode has been started, it evaluates, through an input signal from the detecting means 6, whether or not the user has brought the terminal into contact with his or her ear. Upon determination that the user of the terminal has brought the terminal into contact with the ear, the CPU 2 causes the controlling means 8 to stop the supply of power from the power supply 7, to stop operation of the displaying means 9 and the lighting means 10. Moreover, upon identification that the call has been terminated, through an input signal from the signal processing portion 3, the CPU 2 outputs, to the controlling means 8, a signal that starts the supply of power from the power supply 7, starting operation of the displaying means 9 and the lighting means 10.” Numazawa at ¶ 0017.

“Next, in Step S2, in order to evaluate whether or not a call has been started, the CPU 2 monitors the output signal from the signal processing portion 3. If here the CPU 2 identifies, from the output signal from the signal processing portion 3, that a call has been a started, processing advances to Step S3.” Numazawa at ¶ 0019.

“In Step S3, the output signal from the detecting means 6 is monitored in order to detect whether the user of the wireless terminal has brought the terminal to the ear in the attitude of a call. In this case, when it has been identified, from the output signal from the detecting means 6, that the terminal is in contact with the ear of the user, processing advances to Step S4. Moreover, if it is identified, from the output signal from the detecting means 6, that the terminal is not in contact with the ear of the user, Step S3 is repeated.” Numazawa at ¶ 0020.

“Following this, in Step S4, the CPU 2 outputs, to the controlling means 8, a signal for stopping the displaying means 9 and the lighting means 10. Through this, the controlling means 8 stop the supply of power from the power supply 7 to the displaying means 9 and the lighting means 10, and the displaying means 9 and lighting means 10 stop operating. Thereafter, processing advances to Step S5, and the call is carried out in a state wherein unnecessary power consumption has been reduced.” Numazawa at ¶ 0021.

“Next, referencing FIG. 3, in Step S6 the CPU 2 monitors the output signal from the detecting means 6 in order to detect whether or not a call is in progress and the user has the terminal in the attitude of a call. When, in this case, it is identified, from the output signal from the detecting means 6, that the terminal has been separated from the ear of the user, processing advances to Step S7. If the CPU 2 identifies, from the output signal from the detecting means 6, that the terminal is still in contact with the ear of the user, processing advances to Step S11.” Numazawa at ¶ 0022.

“Next, in Step S7, the CPU 2 outputs, to the controlling means 8, a signal to start operation of the displaying means 9 and the lighting means 10. Through this, the controlling means 8 start the operation of the displaying means 9 and the lighting

means 10 through causing power to be supplied to the displaying means 9 and the lighting means 10 from the power supply 7. Thereafter, processing advances to Step S8.” Numazawa at ¶ 0023.

“Following this, in Step S8, the CPU 2 monitors the output signal from the detecting means 6 to detect whether or not the user of the terminal has again gone into the attitude of a call. In this case, when the CPU 2 identifies, from the output signal from the detecting means 6, that the terminal is in contact with the ear of the user, processing advances to Step S9. Moreover, if it is identified, from the output signal from the detecting means 6, that the terminal is not in contact with the ear of the user, processing advances to Step S10.” Numazawa at ¶ 0024.

“Next, in Step S9, the CPU 2, in order to again stop the displaying means 9 and the lighting means 10, outputs, to the controlling means 8, a signal to stop the displaying means 9 and the lighting means 10. Through this, the controlling means 8 stop the supply of power from the power supply 7 to the displaying means 9 and the lighting means 10, to thereby stop operation of the displaying means 9 and the lighting means 10. Thereafter, processing returns to Step S6.” Numazawa at ¶ 0025.

“Following this, in Step S10, the CPU 2 monitors the output signal from the signal processing portion 3 to detect whether or not the wireless terminal has gone into the call terminating state. When, in this case, the CPU 2 identifies, from the output signal from the signal processing portion 3, that the call has been terminated, the displaying means 9 and the lighting means 10 are already operating, so the procedure is terminated, without performing any processing. If it is identified, from the output signal from the signal processing portion 3, that the call has not been terminated, processing returns to Step S8.” Numazawa at ¶ 0026.

“Following this, in Step S11, the CPU 2 monitors the output signal from the signal processing portion 3 to detect whether or not the wireless terminal has gone into the call terminating state. Next, in Step S11, the CPU 2 monitors the output signal from the signal processing portion to detect whether or not the wireless terminal has gone into a call-terminated state. At this time, if the CPU 2 identifies, from the output signal from the signal processing portion 3, that the call has been terminated, processing advances to Step S12. If it is identified, from the output signal from the signal processing portion 3, that the call has not been terminated, processing returns to Step S6.” Numazawa at ¶ 0027.

“Following this, in Step S12, the CPU 2 outputs a signal to the controlling means 8 to start operation of the displaying means 9 and the lighting means 10, in order to start the operation of the displaying means 9 and the lighting means 10. Through this, the controlling means 8 start the operation of the displaying means 9 and the lighting means 10 through causing power to be supplied to the displaying means 9 and the lighting means 10 from the power supply 7.” Numazawa at ¶ 0028.

“

FIG. 2

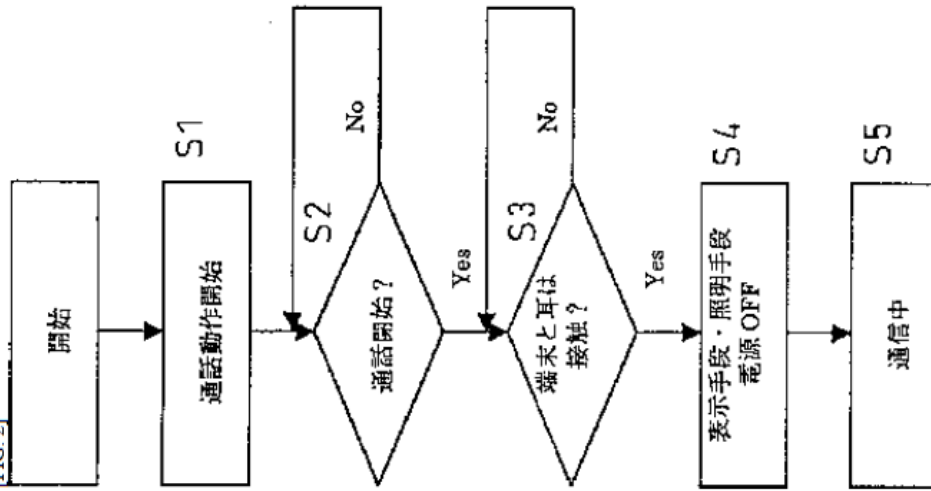

[TOP] Start
S1: Begin Call Operation
S2: Call started?
S3: Terminal and ear in contact?
S4: Turn displaying means/lighting means power supply off.
S5: In Call

»

<p>[1g] the telephone call is a wireless telephone call;</p>	<p>Numazawa discloses the telephone call as a wireless telephone call.</p> <p>For example:</p> <p><i>See</i> discussions of claim elements [1a] and [1d], <i>supra</i>, which are incorporated herein by reference.</p> <p>“The present invention relates to a reduced power consumption controlling method in a wireless terminal for reducing power consumption by stopping operation of unnecessary functions during a call.” Numazawa at ¶ 0001.</p> <p>“In the present invention, control is such that, upon determination that the wireless terminal is in a call, operation of functions believe be unnecessary, due to the user of the terminal being in a call, is stopped, and upon termination of the call, operation of the stopped functions is restarted.” Numazawa at ¶ 0005.</p> <p>“FIG. 1 depicts the structure of a wireless terminal in one embodiment according to the present invention, wherein: 1 is a wireless terminal; 2 is a CPU for evaluating whether or not the wireless terminal is in a call state, whether or not the user has the receiver against his/her ear, etc., and for controlling switching means for starting and stopping the supply of power to the functional block; 3 is a signal processing portion for processing signals of a base station; 4 is an RF transceiving portion for sending and receiving radio signals through an antenna wire 5; 6 is detecting means for detecting whether or not the user of the terminal has contacted his/her ear to the terminal; 7 is a power supply for supply electric power to displaying means and lighting means; 8 is controlling means for controlling the displaying means and lighting means depending on the evaluation by the CPU 2; 9 is displaying means for displaying text, the state of</p>
--	---

the terminal, etc.; and 10 is lighting means, such as a backlight, or the like.”
 Numazawa at ¶ 0016.

“

[FIG. 1]

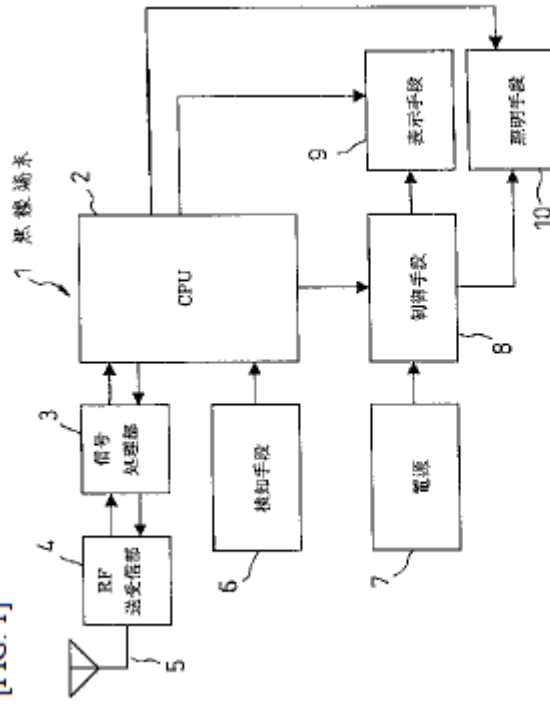

- 4: RF Transceiving Portion
- 3: Signal Processing Portion
- 1: Wireless Terminal
- 6: Detecting Means
- 7: Power Supply
- 8: Controlling Means
- 9: Displaying Means
- 10: Lighting Means

Numazawa at Fig 1.

”

<p>[1h] the microprocessor reduces power to the display while the signal indicates the proximity of the external object only if the microprocessor determines that the wireless telephone call is active; and</p>	<p>Numazawa discloses that the microprocessor reduces power to the display while the signal indicates the proximity of the external object only if the microprocessor determines that the wireless telephone call is active.</p> <p>For example:</p> <p><i>See</i> discussion of claim element [1f], <i>supra</i>, which is incorporated herein by reference.</p> <p>“In the invention set forth in Claim 6, during a call, whether operation of a function is necessary or not is evaluated through whether or not the receiver is in contact with the ear of the user, and thus there is the effect of being able to start operation of a function immediately when it becomes necessary to start the operation of a function that has been stopped, when the receiver is removed from the ear of the user, even when in a call state.” Numazawa at ¶ 0014.</p> <p>“When the CPU 2 identifies, through an input signal from the signal processing portion 3, that the call mode has been started, it evaluates, through an input signal from the detecting means 6, whether or not the user has brought the terminal into contact with his or her ear. Upon determination that the user of the terminal has brought the terminal into contact with the ear, the CPU 2 causes the controlling means 8 to stop the supply of power from the power supply 7, to stop operation of the displaying means 9 and the lighting means 10.” Numazawa at ¶ 0017.</p> <p>“Next, in Step S2, in order to evaluate whether or not a call has been started, the CPU 2 monitors the output signal from the signal processing portion 3. If here the CPU 2</p>
---	--

identifies, from the output signal from the signal processing portion 3, that a call has been a started, processing advances to Step S3.” Numazawa at ¶ 0019.

“In Step S3, the output signal from the detecting means 6 is monitored in order to detect whether the user of the wireless terminal has brought the terminal to the ear in the attitude of a call. In this case, when it has been identified, from the output signal from the detecting means 6, that the terminal is in contact with the ear of the user, processing advances to Step S4. Moreover, if it is identified, from the output signal from the detecting means 6, that the terminal is not in contact with the ear of the user, Step S3 is repeated.” Numazawa at ¶ 0020.

“Following this, in Step S4, the CPU 2 outputs, to the controlling means 8, a signal for stopping the displaying means 9 and the lighting means 10. Through this, the controlling means 8 stop the supply of power from the power supply 7 to the displaying means 9 and the lighting means 10, and the displaying means 9 and lighting means 10 stop operating. Thereafter, processing advances to Step S5, and the call is carried out in a state wherein unnecessary power consumption has been reduced.” Numazawa at ¶ 0021.

“

FIG. 2

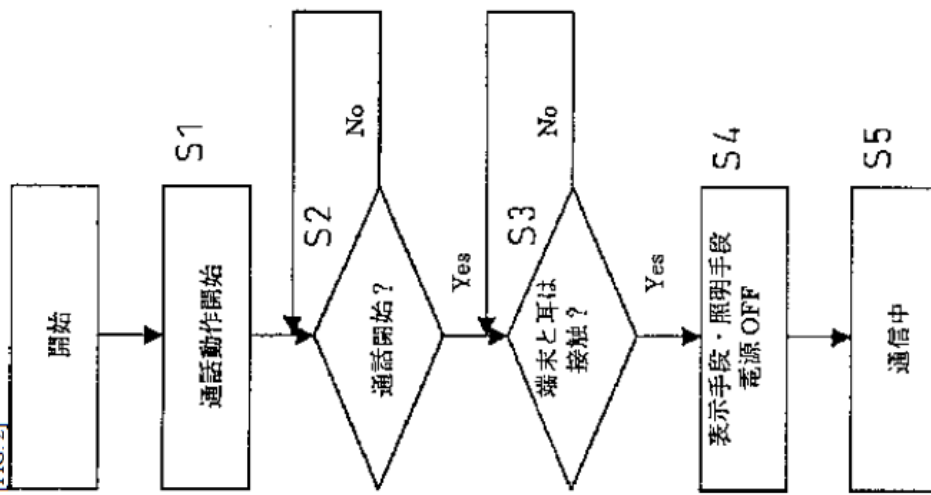

[TOP] Start
S1: Begin Call Operation
S2: Call started?
S3: Terminal and ear in contact?
S4: Turn displaying means/lighting means power supply off.
S5: In Call

»

	<p>Numazawa at Fig 2.</p> <p>“A reduced power consumption controlling method for a wireless terminal as set forth in any of Claim 1 through 5, wherein: during a call, whether the operation of functions such as displaying means, lighting means, or the like, of a wireless terminal should be stopped or caused to operate is evaluated through detecting contact or non-contact between a receiver and an ear of a user.” Numazawa at Claim 6.</p>
<p>[14] the proximity sensor begins detecting whether an external object is proximate substantially concurrently with the mobile station initiating an outgoing wireless telephone call or receiving an incoming wireless telephone call.</p>	<p>Numazawa discloses that the proximity sensor begins to detect whether an external object is proximate substantially concurrently with the mobile station initiating an outgoing wireless telephone call or receiving an incoming wireless telephone call:</p> <p>For example:</p> <p><i>See</i> discussion of claim element [1f], <i>supra</i>, which is incorporated herein by reference.</p> <p>“When the CPU 2 identifies, through an input signal from the signal processing portion 3, that the call mode has been started, it evaluates, through an input signal from the detecting means 6, whether or not the user has brought the terminal into contact with his or her ear.” Numazawa at ¶ 0017.</p> <p>“Next, in Step S2, in order to evaluate whether or not a call has been started, the CPU 2 monitors the output signal from the signal processing portion 3. If here the CPU 2 identifies, from the output signal from the signal processing portion 3, that a call has been a started, processing advances to Step S3.” Numazawa at ¶ 0019.</p>

“In Step S3, the output signal from the detecting means 6 is monitored in order to detect whether the user of the wireless terminal has brought the terminal to the ear in the attitude of a call.” Numazawa at ¶ 0020.

“

FIG. 2

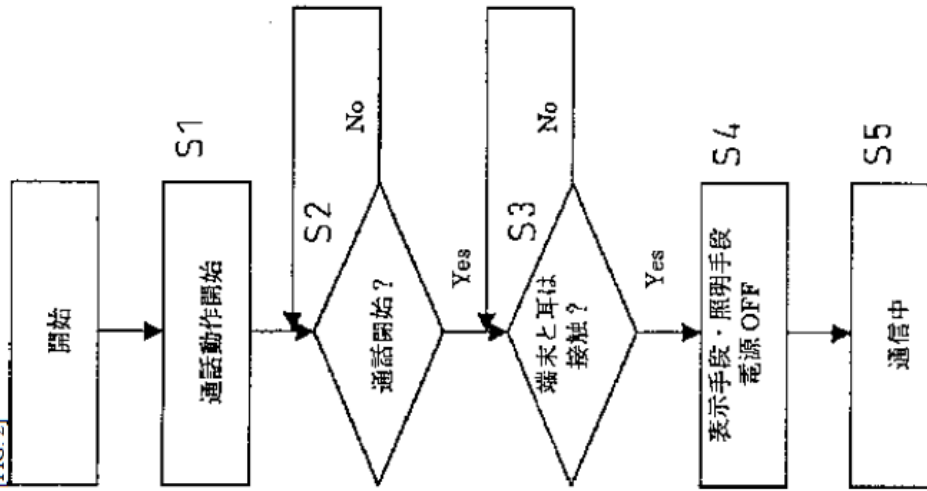

[TOP] Start
S1: Begin Call Operation
S2: Call started?
S3: Terminal and ear in contact?
S4: Turn displaying means/lighting means power supply off.
S5: In Call

»

Numazawa at Fig. 2.

To the extent Numazawa is deemed to not expressly disclose “the proximity sensor begins detecting whether an external object is proximate substantially concurrently with the mobile station initiating an outgoing wireless telephone call or receiving an incoming wireless telephone call,” Numazawa inherently discloses this limitation. In Numazawa, the CPU 2 monitors the output signal from the detecting means 6 only after the CPU 2 identifies that a call has been started. A person of ordinary skill in the art at the time of the alleged invention would understand that “initiating an outgoing wireless telephone call or receiving an incoming wireless telephone call” is necessarily how a call is started. Further, a person of ordinary skill in the art would understand that “the proximity sensor begins detecting whether an external object is proximate substantially concurrently with the mobile station initiating an outgoing wireless telephone call or receiving an incoming wireless telephone call” because Numazawa discloses that this is when the CPU 2 monitors the output signal from the detecting means. Thus, a person of ordinary skill in the art at the time of the alleged invention would understand Numazawa to inherently disclose that “the proximity sensor begins detecting whether an external object is proximate substantially concurrently with the mobile station initiating an outgoing wireless telephone call or receiving an incoming wireless telephone call or receiving an incoming wireless telephone call.”

To the extent Numazawa is deemed to not expressly or inherently disclose “the proximity sensor begins detecting whether an external object is proximate substantially concurrently with the mobile station initiating an outgoing wireless telephone call or receiving an incoming wireless telephone call,” Numazawa renders it obvious to one of skill in the art to have “the proximity sensor begin[] detecting whether an external object is proximate substantially concurrently with the mobile station initiating an outgoing wireless telephone call or receiving an incoming wireless telephone call.” A person of ordinary skill in the art at the time of the alleged invention would understand that “initiating an outgoing wireless telephone call or receiving an incoming wireless telephone call” is necessarily how a call is started. Further, it would be obvious to a

person of ordinary skill in the art at the time of the alleged invention for “the proximity sensor [to] begin[] detecting whether an external object is proximate substantially concurrently with the mobile station initiating an outgoing wireless telephone call or receiving an incoming wireless telephone call” because that is the only time when Numazawa discloses that the CPU 2 monitors the output signal for the detecting means. Because this is the only time that the signal is monitored, it would be obvious to a person of ordinary skill in the art at the time of the alleged invention that the proximity sensor should begin detecting substantially concurrently with the start of this period in order to save additional power.

To the extent Numazawa is deemed to not expressly or inherently disclose “the proximity sensor begins detecting whether an external object is proximate substantially concurrently with the mobile station initiating an outgoing wireless telephone call or receiving an incoming wireless telephone call,” it would be obvious to combine the disclosure of Numazawa with those of Fukiharu 598 as described in the Fukiharu 598 claim chart, which is incorporated herein in its entirety by reference. Numazawa and Fukiharu 598 are both directed to conserving battery power in mobile stations generally and more particularly at conserving battery power in mobile stations by using sensors to detect when the user of the mobile station is in a call and unlikely to be looking at the display (as when, for example, the proximity sensor detects the user’s ear by the mobile station) and to power off the display of mobile stations at such times. Numazawa at ¶ Abstract (“To achieve reduced power consumption through stopping operation of unnecessary functions during use of a wireless terminal. A CPU 2 identifies start of a call state through a signal from a signal processing portion 3 for controlling communication with a base station, and identifies, through an output signal from detecting means 6, whether or not a user ear is in contact with a terminal. Upon identification of contact of the ear to the terminal, controlling means 8 are caused to stop the supply of electric power, from a power supply 7, to displaying means 9 for providing information to a user, and lighting means 10, such as a black light.”), ¶ 0005-0007 (“In the present invention, control is such that, upon determination that the wireless terminal is in a call, operation of functions believe be unnecessary, due to the user of the terminal being in a call, is stopped, and upon termination of the call,

operation of the stopped functions is restarted. Additionally, because it is envisioned that there will also be cases where, even during a call, the face of the user may be separated from the receiver of the terminal, control is performed so as to enable restarting of the operations of the functions that had been stopped as unnecessary, through detecting whether or not the user of the terminal has the receiver in contact with an ear. The achievement of reduced power consumption through stopping operation of functions that become unnecessary in use of the terminal, as described above, can be anticipated to have the effect of extending the life of the power supply, such as a battery.”); Fukiharu 598 at ¶ 0018 (“The present invention, through the use of a structure as described above, enables a reduction in the consumption of battery power, through enabling the lighting devices to be turned OFF when the ear is caused to contact the receiver portion in order to hear the receiver sound during voice communications of a mobile telephone when the lighting devices (backlights) for a liquid crystal display device and keypad portion of a mobile telephone are lit, such as that night.”). A person of ordinary skill in the art at the time of the alleged invention would be motivated to modify Numazawa to have “the proximity sensor begin[] detecting whether an external object is proximate substantially concurrently with the mobile station initiating an outgoing wireless telephone call or receiving an incoming wireless telephone call” as disclosed in Fukiharu 598 because the proximity sensor does not need to be detecting when its output is not being monitored, and beginning detecting only during the period when the signal is being monitored would save additional power. The combination would constitute, at least, combining prior art elements according to known methods to yield predictable results, a simple substitution of one known element for another to obtain predictable results, the use of a known technique to improve similar devices in the same way, the application of a known technique to a known device ready for improvement to yield a predictable result, and obvious to try.

To the extent Numazawa is deemed to not expressly or inherently disclose “the proximity sensor begins detecting whether an external object is proximate substantially concurrently with the mobile station initiating an outgoing wireless telephone call or receiving an incoming wireless telephone call,” it would be obvious to combine the

disclosure of Numazawa with those of Miyashita as described in the Miyashita claim chart, which is incorporated herein in its entirety by reference. Numazawa and Miyashita are both directed to conserving battery power in mobile stations generally and more particularly at conserving battery power in mobile stations by using sensors to detect when the user of the mobile station is in a call and unlikely to be looking at the display (as when, for example, the proximity sensor detects the user's ear by the mobile station or a sensor detects that the mobile station is in a vertical orientation) and to power off the display of mobile stations at such times. Numazawa at ¶ Abstract (“To achieve reduced power consumption through stopping operation of unnecessary functions during use of a wireless terminal. A CPU 2 identifies start of a call state through a signal from a signal processing portion 3 for controlling communication with a base station, and identifies, through an output signal from detecting means 6, whether or not a user ear is in contact with a terminal. Upon identification of contact of the ear to the terminal, controlling means 8 are caused to stop the supply of electric power, from a power supply 7, to displaying means 9 for providing information to a user, and lighting means 10, such as a black light.”), ¶ 0005-0007 (“In the present invention, control is such that, upon determination that the wireless terminal is in a call, operation of functions believe be unnecessary, due to the user of the terminal being in a call, is stopped, and upon termination of the call, operation of the stopped functions is restarted. Additionally, because it is envisioned that there will also be cases where, even during a call, the face of the user may be separated from the receiver of the terminal, control is performed so as to enable restarting of the operations of the functions that had been stopped as unnecessary, through detecting whether or not the user of the terminal has the receiver in contact with an ear. The achievement of reduced power consumption through stopping operation of functions that become unnecessary in use of the terminal, as described above, can be anticipated to have the effect of extending the life of the power supply, such as a battery.”); Miyashita at 3:58-4:2 (“In contrast, the display control portion 17 is responsive to the inclination angle information indicative of variation of the inclination angle from the substantially horizontal orientation to the substantially vertical orientation while it performs display control for the display portion 16 to display the control information, to terminate the power supply for the display portion 16. When speaking is performed with the destination person via the speaker 12 and the microphone 14, it is rare to require seeing the display content on the display portion 16. Therefore, the power supply for the display portion 16 is shut

	<p>down. Thus, exhausting of a battery can be reduced.”). While Miyashita discloses a gyro, it would be obvious to one of ordinary skill in the art at the time of the alleged invention to make Numazawa’s proximity sensor to function in the same way as the gyro in Miyashita as both sensors serve the same function (to serve as an indication that the mobile station’s display is unlikely to be viewed and can therefore be powered off). A person of ordinary skill in the art at the time of the alleged invention would therefore be motivated to modify Numazawa to have “the proximity sensor begin[] detecting whether an external object is proximate substantially concurrently with the mobile station initiating an outgoing wireless telephone call or receiving an incoming wireless telephone call” as disclosed in Miyashita because the proximity sensor does not need to be detecting when its output is not being monitored, and beginning detecting only during the period when the signal is being monitored would save additional power. The combination would constitute, at least, combining prior art elements according to known methods to yield predictable results, a simple substitution of one known element for another to obtain predictable results, the use of a known technique to improve similar devices in the same way, the application of a known technique to a known device ready for improvement to yield a predictable result, and obvious to try.</p>
<p>[Claim 2] The mobile station of claim 1, wherein the microprocessor reduces power to the display only if (i) the microprocessor determines that a telephone call is active and (ii) the signal indicates the proximity of the external object.</p>	<p>Numazawa discloses the microprocessor reducing power to the display only if (i) the microprocessor determines that a telephone call is active and (ii) the signal indicates the proximity of the external object.</p> <p>For example:</p> <p><i>See</i> discussion of claim element [1h], <i>supra</i>, which is incorporated herein by reference.</p>
<p>[Claim 4] The mobile station as recited in claim 1, wherein the microprocessor reduces power to the display by turning off the display.</p>	<p>Numazawa discloses the microprocessor reducing power to the display by turning off the display.</p>

For example:

See discussion of claim element [1f], *supra*, which is incorporated herein by reference.

“A CPU 2 identifies start of a call state through a signal from a signal processing portion 3 for controlling communication with a base station, and identifies, through an output signal from detecting means 6, whether or not a user ear is in contact with a terminal. Upon identification of contact of the ear to the terminal, controlling means 8 are caused to stop the supply of electric power, from a power supply 7, to displaying means 9 for providing information to a user, and lighting means 10, such as a black light.” Numazawa at Abstract.

“Following this, in Step S4, the CPU 2 outputs, to the controlling means 8, a signal for stopping the displaying means 9 and the lighting means 10. Through this, the controlling means 8 stop the supply of power from the power supply 7 to the displaying means 9 and the lighting means 10, and the displaying means 9 and lighting means 10 stop operating.” Numazawa at ¶ 0021.

“Next, in Step S9, the CPU 2, in order to again stop the displaying means 9 and the lighting means 10, outputs, to the controlling means 8, a signal to stop the displaying means 9 and the lighting means 10. Through this, the controlling means 8 stop the supply of power from the power supply 7 to the displaying means 9 and the lighting means 10, to thereby stop operation of the displaying means 9 and the lighting means 10.” Numazawa at ¶ 0025.

“

FIG. 2

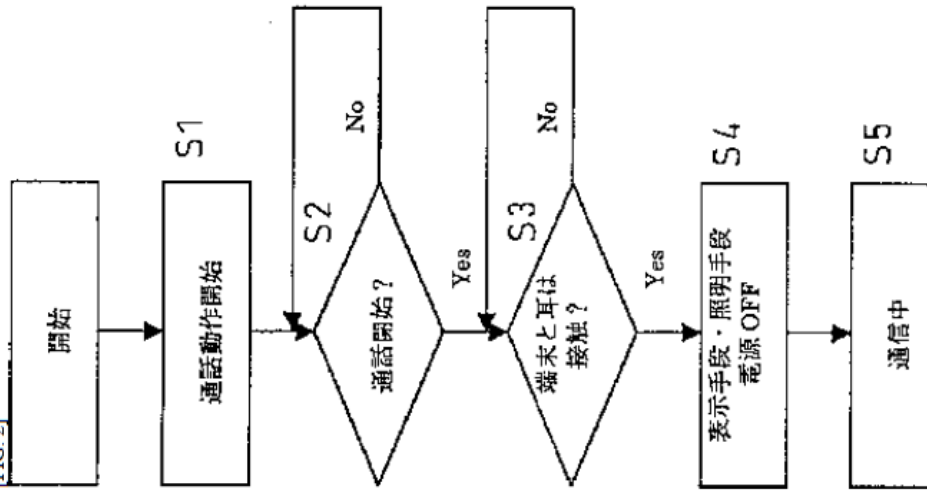

[TOP] Start
S1: Begin Call Operation
S2: Call started?
S3: Terminal and ear in contact?
S4: Turn displaying means/lighting means power supply off.
S5: In Call

»

Numazawa at Fig. 2.

“

[FIG. 3]

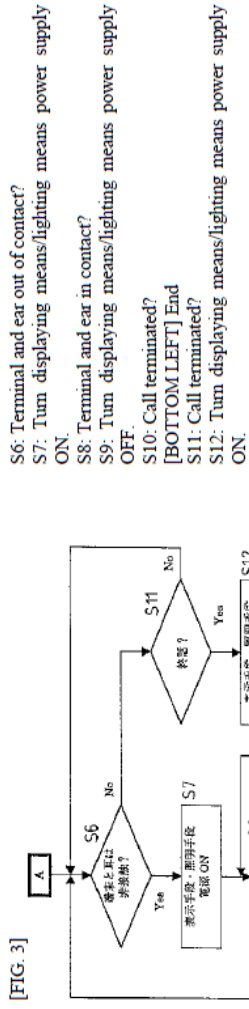

”

Numazawa at Fig. 3.

[Claim 5] The mobile station as recited in claim 1, wherein the proximity sensor is a mechanical proximity sensor, an optical proximity sensor, an optical sensor, or a range-detecting sensor.

Numazawa discloses that the proximity sensor is a mechanical proximity sensor, an optical sensor, or a range-detecting sensor.

For example:

“A CPU 2 identifies start of a call state through a signal from a signal processing portion 3 for controlling communication with a base station, and identifies, through an output signal from detecting means 6, whether or not a user ear is in contact with a terminal. Upon identification of contact of the ear to the terminal, controlling means 8 are caused to stop the supply of electric power, from a power supply 7, to displaying means 9 for providing information to a user, and lighting means 10, such as a black light.” Numazawa at Abstract.

“In the invention set forth in Claim 6, during a call, whether operation of a function is necessary or not is evaluated through whether or not the receiver is in contact with the ear of the user, and thus there is the effect of being able to start operation of a function immediately when it becomes necessary to start the operation of a function that has been stopped, when the receiver is removed from the ear of the user, even when in a call state.” Numazawa at ¶ 0014.

“FIG. 1 depicts the structure of a wireless terminal in one embodiment according to the present invention, wherein: . . . 6 is detecting means for detecting whether or not the user of the terminal has contacted his/her ear to the terminal . . .” Numazawa at ¶ 0016.

“When the CPU 2 identifies, through an input signal from the signal processing portion 3, that the call mode has been started, it evaluates, through an input signal from the detecting means 6, whether or not the user has brought the terminal into contact with his or her ear. Upon determination that the user of the terminal has brought the terminal into contact with the ear, the CPU 2 causes the controlling means 8 to stop the supply of power from the power supply 7, to stop operation of the displaying means 9 and the lighting means 10.” Numazawa at ¶ 0017.

“A reduced power consumption controlling method for a wireless terminal as set forth in any of Claim 1 through 5, wherein: during a call, whether the operation of functions such as displaying means, lighting means, or the like, of a wireless terminal should be stopped or caused to operate is evaluated through detecting contact or non-contact between a receiver and an ear of a user.” Numazawa at Claim 6.

To the extent Numazawa is deemed to not expressly disclose “the proximity sensor is a mechanical proximity sensor, an optical sensor, or a range-detecting sensor,” Numazawa inherently discloses this limitation. In Numazawa, the detecting means is able to detect whether the user has contacted his or her ear to the terminal. A person of ordinary skill in the art at the time of the alleged invention would understand that detecting this contact is necessarily accomplished by mechanical proximity sensor. Thus, a person of ordinary skill in the art at the time of the alleged invention would understand Numazawa to inherently disclose “the proximity sensor is a mechanical proximity sensor, an optical sensor, or a range-detecting sensor.”

To the extent Numazawa is deemed to not expressly or inherently disclose “the proximity sensor is a mechanical proximity sensor, an optical sensor, or a range-detecting sensor,” Numazawa renders it obvious to one of skill in the art to use a mechanical proximity sensor. A person of ordinary skill in the art at the time of the alleged invention would be aware of “conventional mechanical proximity (load) sensors,” which the ’889 Patent identifies as known prior art. See ’889 Patent at 3:15-20. A person of ordinary skill in the art at the time of the alleged invention would understand that a mechanical proximity sensor could be used to detect contact with the user. Using a mechanical proximity sensor would constitute, at least, combining prior art elements according to known methods to yield predictable results, a simple substitution of one known element for another to obtain predictable results, the use of a known technique to improve similar devices in the same way, the application of a

	<p>known technique to a known device ready for improvement to yield a predictable result, and obvious to try.</p>
<p>[Claim 6] The mobile station as recited in claim 1, wherein the proximity sensor is located proximate to the display.</p>	<p>Numazawa discloses that the proximity sensor is located proximate to the display.</p> <p>For example:</p> <p>“On the other hand, in a conventional wireless terminal, electric power is consumed unnecessarily during the interval between when the power supply is started and the power supply is cut, through the function for displaying text, and the like, operating constantly, regardless the mode of the wireless terminal and the state of the user.” Numazawa at ¶ 0003.</p> <p>“Moreover, stopping the operation of unnecessary functions can be anticipated to have the effect of reducing burnout of the light emitting components, such as LEDs, used in the backlight, or the like, and of reducing burn-in of display devices, such as LCDs, used for performing those functions.” Numazawa at ¶ 0008.</p> <p>“In the invention set forth in Claim 2, in a wireless terminal that has displaying means such as for communicating, to the user, information such as displaying the time or indicating the operating mode of the terminal, through functions such as a text display, illumination of an LED, or the like, an evaluation is performed as to whether or not in a call, and if in a call, the display on the displaying means, which is believed to not be visible, is stopped, and when the call is terminated, the display on the displaying means that has been stopped is restarted, so there is the effect of reducing unnecessary power</p>

consumption during a call, and the effect of reducing burnout of components used in the displaying means.” Numazawa at ¶ 0010.

“In the invention set forth in Claim 3, in a state wherein the display on the displaying means is stopped due to being in a call, an evaluation is performed as to whether or not the display on the displaying means is necessary, and if the evaluation is that it is necessary, the display on the displaying means that was stopped is restarted, so there is the effect of performing the display as normal if the user of the terminal separates the receiver from his/her face in order to view the display.” Numazawa at ¶ 0011.

“FIG. 1 depicts the structure of a wireless terminal in one embodiment according to the present invention, wherein: 1 is a wireless terminal; 2 is a CPU for evaluating whether or not the wireless terminal is in a call state, whether or not the user has the receiver against his/her ear, etc., and for controlling switching means for starting and stopping the supply of power to the functional block; . . . 6 is detecting means for detecting whether or not the user of the terminal has contacted his/her ear to the terminal; . . .” Numazawa at ¶ 0016.

To the extent Numazawa is deemed to not expressly disclose “the proximity sensor is located proximate to the display,” Numazawa inherently discloses this limitation. Numazawa discloses that its invention cuts power to the display during a call when the user has the receiver against his or her ear because the display is an unnecessary function at this time, i.e., it is not visible. A person of ordinary skill in the art at the time of the alleged invention would understand that the display is not visible because the user’s head is against it and, if the detecting means is to detect this, it necessarily would be “located proximate to the display.” Thus, a person of ordinary skill in the art at the time of the alleged invention would understand Numazawa to inherently disclose that “the proximity sensor is located proximate to the display.”

To the extent Numazawa is deemed to not expressly or inherently disclose “the proximity sensor is located proximate to the display,” Numazawa renders it obvious to one of skill in the art to have “the proximity sensor . . . located proximate to the display.” It would be obvious to a person of ordinary skill in the art at the time of the alleged invention that “the proximity sensor is located proximate to the display” because, in this location, it can determine that the display is not visible because the user’s head is against it. This would constitute, at least, combining prior art elements according to known methods to yield predictable results, a simple substitution of one known element for another to obtain predictable results, the use of a known technique to improve similar devices in the same way, the application of a known technique to a known device ready for improvement to yield a predictable result, and obvious to try.

To the extent Numazawa is deemed to not expressly or inherently disclose “the proximity sensor is located proximate to the display,” it would be obvious to combine the disclosure of Numazawa with those of Fukiharu 598 as described in the Fukiharu 598 claim chart, which is incorporated herein in its entirety by reference. Numazawa and Fukiharu 598 are both directed to conserving battery power in mobile stations generally and more particularly at conserving battery power in mobile stations by using sensors to detect when the user of the mobile station is in a call and unlikely to be looking at the display (as when, for example, the proximity sensor detects the user’s ear by the mobile station) and to power off the display of mobile stations at such times. Numazawa at ¶ Abstract (“To achieve reduced power consumption through stopping operation of unnecessary functions during use of a wireless terminal. A CPU 2 identifies start of a call state through a signal from a signal processing portion 3 for controlling communication with a base station, and identifies, through an output signal from detecting means 6, whether or not a user ear is in contact with a terminal. Upon identification of contact of the ear to the terminal, controlling means 8 are caused to stop the supply of electric power, from a power supply 7, to displaying means 9 for providing information to a user, and lighting means 10, such as a black light.”), ¶ 0005-0007 (“In the present invention, control is such that, upon determination that the

	<p>wireless terminal is in a call, operation of functions believe be unnecessary, due to the user of the terminal being in a call, is stopped, and upon termination of the call, operation of the stopped functions is restarted. Additionally, because it is envisioned that there will also be cases where, even during a call, the face of the user may be separated from the receiver of the terminal, control is performed so as to enable restarting of the operations of the functions that had been stopped as unnecessary, through detecting whether or not the user of the terminal has the receiver in contact with an ear. The achievement of reduced power consumption through stopping operation of functions that become unnecessary in use of the terminal, as described above, can be anticipated to have the effect of extending the life of the power supply, such as a battery.”; Fukiharu 598 at ¶ 0018 (“The present invention, through the use of a structure as described above, enables a reduction in the consumption of battery power, through enabling the lighting devices to be turned OFF when the ear is caused to contact the receiver portion in order to hear the receiver sound during voice communications of a mobile telephone when the lighting devices (backlights) for a liquid crystal display device and keypad portion of a mobile telephone are lit, such as that night.”). A person of ordinary skill in the art at the time of the alleged invention would be motivated to modify Numazawa to have “the proximity sensor is located proximate to the display” as disclosed in Fukiharu 598 to determine that the display is not visible because the user’s head is against it. The combination would constitute, at least, combining prior art elements according to known methods to yield predictable results, a simple substitution of one known element for another to obtain predictable results, the use of a known technique to improve similar devices in the same way, the application of a known technique to a known device ready for improvement to yield a predictable result, and obvious to try.</p>
<p>[Claim 8 – Preamble] 8. A method of conserving battery power in a mobile station, comprising:</p>	<p>To the extent the preamble is construed as limiting, Numazawa discloses a method of conserving battery power in a mobile station:</p> <p>For example:</p>

	<p>See discussion of claim elements [1a] and 1[f], <i>supra</i>, which are incorporated herein by reference.</p> <p>The present invention relates to a reduced power consumption controlling method in a wireless terminal for reducing power consumption by stopping operation of unnecessary functions during a call. Numazawa at ¶ 0001.</p>
<p>[8a] detecting whether an external object is proximate;</p>	<p>Numazawa discloses detecting whether an external object is proximate.</p> <p>For example:</p> <p>See discussion of claim elements [1b] and 1[e], <i>supra</i>, which are incorporated herein by reference.</p> <p>FIG. 1 depicts the structure of a wireless terminal in one embodiment according to the present invention, wherein: 1 is a wireless terminal; 2 is a CPU for evaluating whether or not the wireless terminal is in a call state, whether or not the user has the receiver against his/her ear, etc., and for controlling switching means for starting and stopping the supply of power to the functional block; . . . 6 is detecting means for detecting whether or not the user of the terminal has contacted his/her ear to the terminal; . . . Numazawa at ¶ 0016.</p> <p>When the CPU 2 identifies, through an input signal from the signal processing portion 3, that the call mode has been started, it evaluates, through an input signal from the detecting means 6, whether or not the user has brought the terminal into contact with his or her ear. Numazawa at ¶ 0017.</p> <p>In Step S3, the output signal from the detecting means 6 is monitored in order to detect whether the user of the wireless terminal has brought the terminal to the ear in</p>

the attitude of a call. In this case, when it has been identified, from the output signal from the detecting means 6, that the terminal is in contact with the ear of the user, processing advances to Step S4. Moreover, if it is identified, from the output signal from the detecting means 6, that the terminal is not in contact with the ear of the user, Step S3 is repeated. Numazawa at ¶ 0020.

Next, referencing FIG. 3, in Step S6 the CPU 2 monitors the output signal from the detecting means 6 in order to detect whether or not a call is in progress and the user has the terminal in the attitude of a call. When, in this case, it is identified, from the output signal from the detecting means 6, that the terminal has been separated from the ear of the user, processing advances to Step S7. If the CPU 2 identifies, from the output signal from the detecting means 6, that the terminal is still in contact with the ear of the user, processing advances to Step S11. Numazawa at ¶ 0022.

Following this, in Step S8, the CPU 2 monitors the output signal from the detecting means 6 to detect whether or not the user of the terminal has again gone into the attitude of a call. In this case, when the CPU 2 identifies, from the output signal from the detecting means 6, that the terminal is in contact with the ear of the user, processing advances to Step S9. Moreover, if it is identified, from the output signal from the detecting means 6, that the terminal is not in contact with the ear of the user, processing advances to Step S10. Numazawa at ¶ 0024.

[FIG. 1]

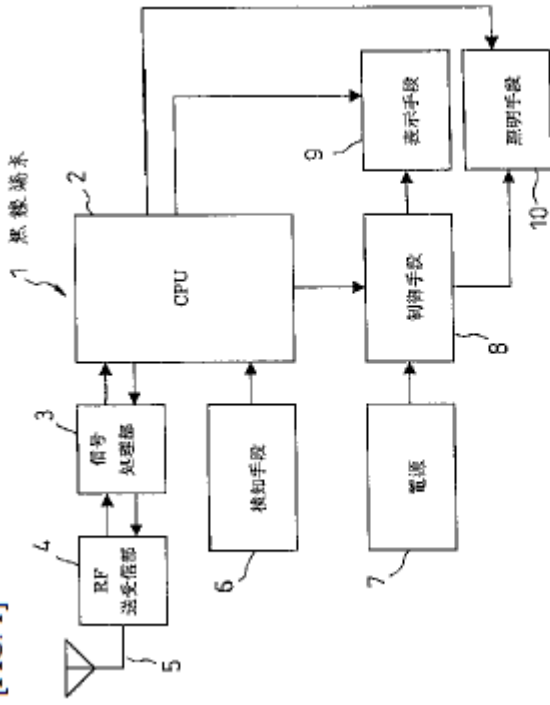

- 4: RF Transceiving Portion
- 3: Signal Processing Portion
- 1: Wireless Terminal
- 6: Detecting Means
- 7: Power Supply
- 8: Controlling Means
- 9: Displaying Means
- 10: Lighting Means

FIG. 2

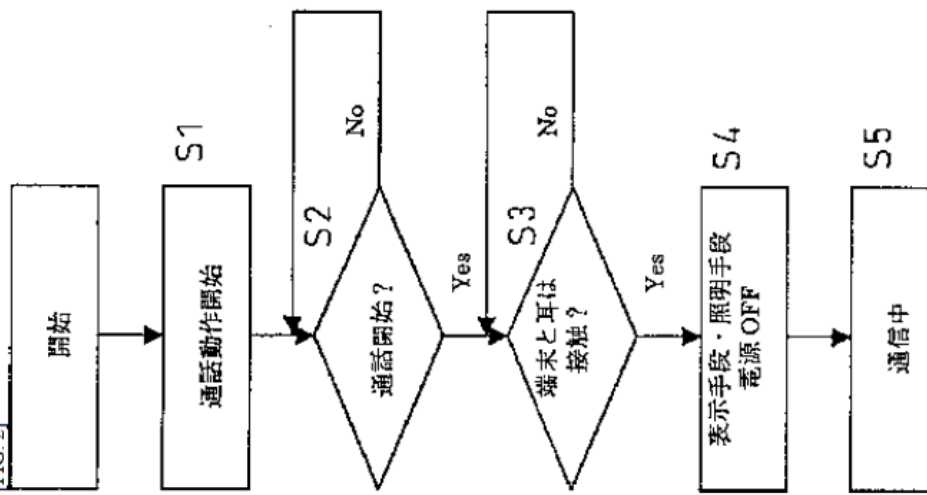

[TOP] Start
S1: Begin Call Operation
S2: Call started?
S3: Terminal and ear in contact?
S4: Turn displaying means/lighting means power supply off.
S5: In Call

	<p>[FIG. 3]</p> <pre> graph TD A[A] --> S6{端末之耳は 接続?} S6 -- Yes --> S7[表示手段、照明手段 ON] S6 -- No --> S11{終端?} S7 --> S8{端末之耳は 接続?} S8 -- Yes --> S9[表示手段、照明手段 電源 OFF] S8 -- No --> S10{接続?} S11 -- Yes --> S12[表示手段、照明手段 電源 ON] S11 -- No --> S10 S10 -- Yes --> End[終了] S12 --> End S9 --> End </pre> <p>S6: Terminal and ear out of contact? S7: Turn displaying means/lighting means power supply ON. S8: Terminal and ear in contact? S9: Turn displaying means/lighting means power supply OFF. S10: Call terminated? [BOTTOM LEFT] End S11: Call terminated? S12: Turn displaying means/lighting means power supply ON.</p>
<p>[8b] determining whether a telephone call is active; and</p>	<p>Numazawa discloses determining whether a telephone call is active.</p> <p>For example:</p> <p>See discussion of claim element [1d], <i>supra</i>, which is incorporated herein by reference.</p>
<p>[8c] reducing power consumption of a display of the mobile station if (i) a telephone call is determined to be active and (ii) the proximity of the external object is detected; wherein:</p>	<p>Numazawa discloses reducing power consumption of a display of the mobile station if (i) a telephone call is determined to be active and (ii) the proximity of the external object is detected.</p> <p>For example:</p>

	<p>See discussion of claim element [1f], <i>supra</i>, which is incorporated herein by reference.</p>
<p>[8d] the telephone call is a wireless telephone call;</p>	<p>Numazawa discloses that the telephone call is a wireless telephone call.</p> <p>For example:</p> <p>See discussion of claim element [1g], <i>supra</i>, which is incorporated herein by reference.</p>
<p>[8e] the power consumption of the display is reduced while the proximity of the external object is detected only if the wireless telephone call is determined to be active; and</p>	<p>Numazawa discloses that the power consumption of the display is reduced while the proximity of the external object is detected only if the wireless telephone call is determined to be active.</p> <p>For example:</p> <p>See discussion of claim element [1h], <i>supra</i>, which is incorporated herein by reference.</p>
<p>[8f] detecting whether an external object is proximate begins substantially concurrently with the mobile station initiating an outgoing wireless telephone call or receiving an incoming wireless telephone call.</p>	<p>Numazawa discloses that detecting whether an external object is proximate begins substantially concurrently with the mobile station initiating an outgoing wireless telephone call or receiving an incoming wireless telephone call.</p> <p>For example:</p> <p>See discussion of claim element [1i], <i>supra</i>, which is incorporated herein by reference.</p> <p>To the extent Numazawa is deemed to not expressly disclose this claim limitation, Numazawa inherently discloses this limitation. See discussion of claim element [1i], <i>supra</i>, which is incorporated herein by reference.</p> <p>To the extent Numazawa is deemed to not expressly or inherently disclose this claim limitation, Numazawa renders it obvious to one of skill in the art at the time of the</p>

	<p>alleged invention. <i>See</i> discussion of claim element [1i], <i>supra</i>, which is incorporated herein by reference.</p> <p>To the extent Numazawa is deemed to not expressly or inherently disclose this claim element, it would be obvious to combine the disclosure of Numazawa with those of Fukiharu 598 as described in the Fukiharu 598 claim chart, which is incorporated herein in its entirety by reference. <i>See</i> discussion of claim element [1i], <i>supra</i>, which is incorporated herein by reference.</p> <p>To the extent Numazawa is deemed to not expressly or inherently disclose this claim limitation, it would be obvious to combine the disclosure of Numazawa with those of Miyashita as described in the Miyashita claim chart, which is incorporated herein in its entirety by reference. <i>See</i> discussion of claim element [1i], <i>supra</i>, which is incorporated herein by reference.</p>
<p>[Claim 12] The method as recited in claim 8, wherein the detecting of the proximity of the external object is performed by a mechanical proximity sensor, an optical sensor, or a range-detecting sensor.</p>	<p>Numazawa discloses that the detecting of the proximity of the external object is performed by a mechanical proximity sensor, an optical sensor, or a range-detecting sensor.</p> <p>For example:</p> <p><i>See</i> discussion of Claim 5, <i>supra</i>, which is incorporated herein by reference.</p> <p>To the extent Numazawa is deemed to not expressly disclose this claim limitation, Numazawa inherently discloses this limitation. <i>See</i> discussion of claim 5, <i>supra</i>, which is incorporated herein by reference.</p> <p>To the extent Numazawa is deemed to not expressly or inherently disclose this claim limitation, Numazawa renders it obvious to one of skill in the art at the time of the alleged invention. <i>See</i> discussion of claim 5, <i>supra</i>, which is incorporated herein by reference.</p>

To the extent Numazawa is deemed to not expressly or inherently disclose this claim element, it would be obvious to combine the disclosure of Numazawa with those of Fukiharu 598 as described in the Fukiharu 598 claim chart, which is incorporated herein in its entirety by reference. *See* discussion of claim 5, *supra*, which is incorporated herein by reference.

To the extent Numazawa is deemed to not expressly or inherently disclose this claim limitation, it would be obvious to combine the disclosure of Numazawa with those of Miyashita as described in the Miyashita claim chart, which is incorporated herein in its entirety by reference. *See* discussion of claim 5, *supra*, which is incorporated herein by reference.

Exhibit A3

**Exhibit #A3 - Miyashita
to Defendants' Preliminary Invalidity Contentions**

**Invalidity Chart for U.S. Patent No. 7,319,889
U.S. Patent No. 5,586,182 (“Miyashita”)**

U.S. Patent No. 5,586,182 to Miyashita (“Miyashita”) was filed on May 1, 1995 and issued on December 17, 1996. Miyashita is prior art to the '889 Patent under at least pre-AIA 35 U.S.C. § 102(e). Miyashita anticipates or renders obvious, alone or in combination with other prior art references, each of the Asserted Claims of the '889 Patent as described in the chart below and in the main invalidity contentions document to which this chart is annexed.

It would have been obvious under 35 U.S.C. § 103 to a person having ordinary skill in the art at the time of the alleged invention to combine the teachings of Miyashita with the following references:

1. Japanese Unexamined Patent Application Publication No. H11-220432 (“Numazawa”). Numazawa qualifies as prior art under at least pre-AIA §§ 102(a), 102(b), and 102(e). Numazawa was published on August 10, 1999.
2. U.S. Patent No. 5,010,566 to Seo (“Seo”). Seo qualifies as prior art under at least pre-AIA 35 U.S.C. §§ 102(a), 102(b), and 102(e). Seo was filed on September 7, 1989 and issued on April 23, 1991.
3. US. Patent Application Publication No. 2004/0225904 A1 to Perez et al. (“Perez”). Perez qualifies as prior art under at least pre-AIA § 102(e). Perez was filed on May 6, 2003 and published on November 11, 2004.

<u>Asserted Claims</u>	<u>Corresponding Disclosure in the Prior Art Reference(s)</u>
[Claim 1 – Preamble] 1. A mobile station, comprising:	<p>Miyashita discloses a mobile station:</p> <p>For example:</p> <p>“For a portable telephone set having a display portion for displaying various information associated with call or origination and reception, a gyro for detecting inclination of a main body is provided.” Miyashita at Abstract.</p>

“The present invention relates to a pocket telephone or portable telephone set. More specifically, the invention relates to a portable telephone set which has a display for displaying various information associated with call origination and reception.”
Miyashita at 1:6-10.

“According to one aspect of the invention, a portable telephone set comprises:
a display device for displaying information associated with a call;
a detector apparatus for detecting the orientation a main body, in which the display means is built-in; and
a control apparatus for controlling power supply for the display depending upon the orientation detected by the detector.”

Miyashita at 1:64-2:5.

FIG. 3

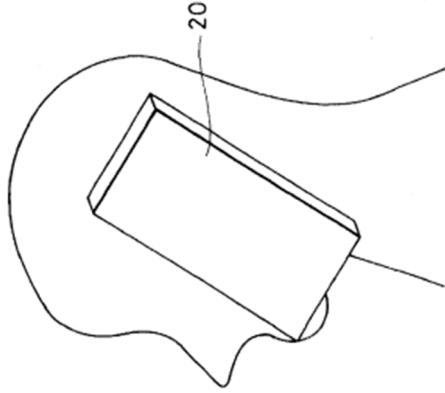
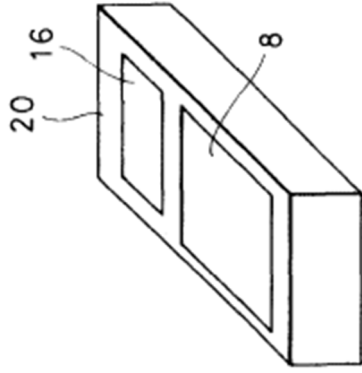

FIG. 2



Miyashita at Figs. 2, 3.

“FIG. 2 is an illustration showing inclination of the main body during a dialing operation for the one embodiment of a portable telephone set according to the invention, and FIG. 3 is an illustration showing inclination of the main body during speaking and not out-dialing for the one embodiment of portable set according to the invention.” Miyashita at 4:3-8.

[1a] a display;

Miyashita discloses a display:

For example:

“For a portable telephone set having a display portion for displaying various information associated with call or origination and reception, a gyro for detecting inclination of a main body is provided.” Miyashita at Abstract.

“The present invention relates to a pocket telephone or portable telephone set. More specifically, the invention relates to a portable telephone set which has a display for displaying various information associated with call origination and reception.” Miyashita at 1:6-10.

“According to one aspect of the invention, a portable telephone set comprises: a display device for displaying information associated with a call;”

Miyashita at 1:64-67.

“FIG. 1 is a block diagram showing a construction of one embodiment of the portable telephone set according to the present invention. FIG. 1, encompasses one embodiment of the portable telephone set according to the invention with substantially the same construction as FIG. 4 except for a display portion 16, a display control portion 17 and a gyro 18 as additional components.” Miyashita at 3:27-33.

FIG. 1

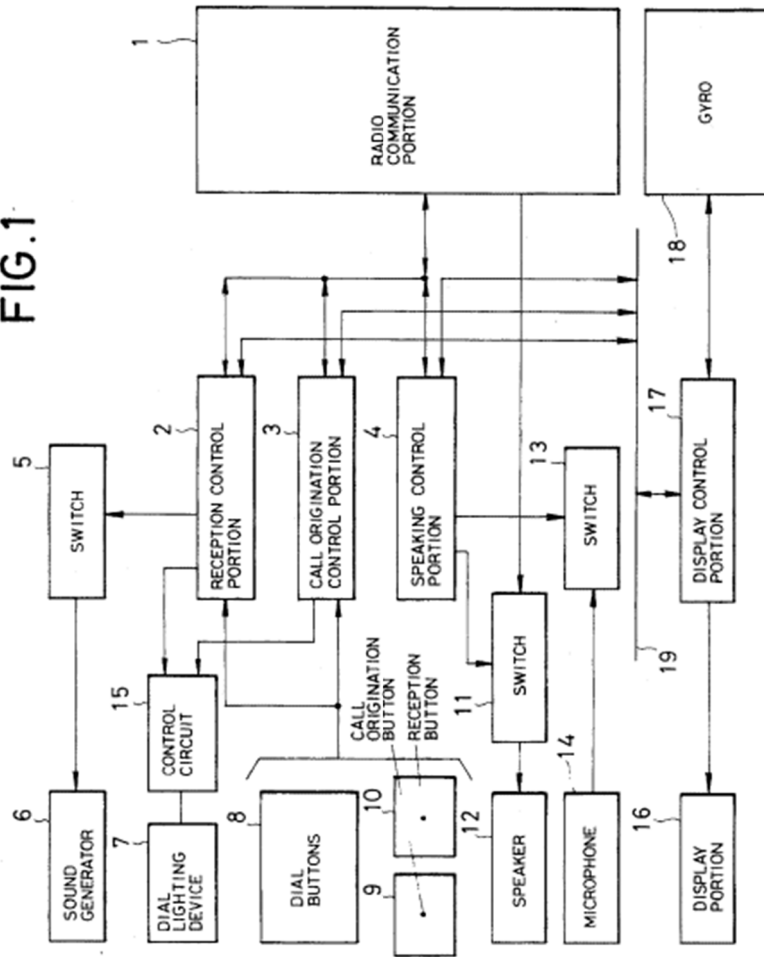

Miyashita at Fig. 1.

“In FIG. 2 when the dial buttons 8 of the portable telephone set are to be operated, the main body 20 should be held in substantially horizontal orientation, directing dial buttons 8 and the display portion 16 upwardly.” Miyashita at 4:9-12.

FIG. 2

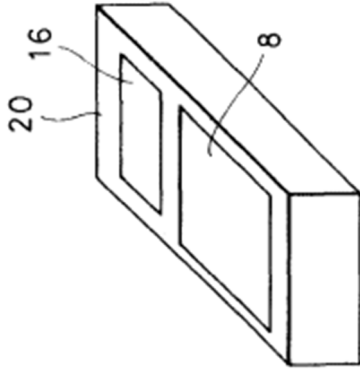

Miyashita at Fig. 2.

“What is claimed is:

1. A portable telephone set comprising:
display for displaying information associated with a call . . .”

Miyashita at Claim 1.

Miyashita discloses a proximity sensor adapted to generate a signal indicative of proximity of an external object:

For example:

“FIG. 1 is a block diagram showing a construction of one embodiment of the portable telephone set according to the present invention. FIG. 1, encompasses one

[1b] a proximity sensor adapted to generate a signal indicative of proximity of an external object; and

embodiment of the portable telephone set according to the invention with substantially the same construction as FIG. 4 except for a display portion 16, a display control portion 17 and a gyro 18 as additional components." Miyashita at 3:27-33.

FIG. 1

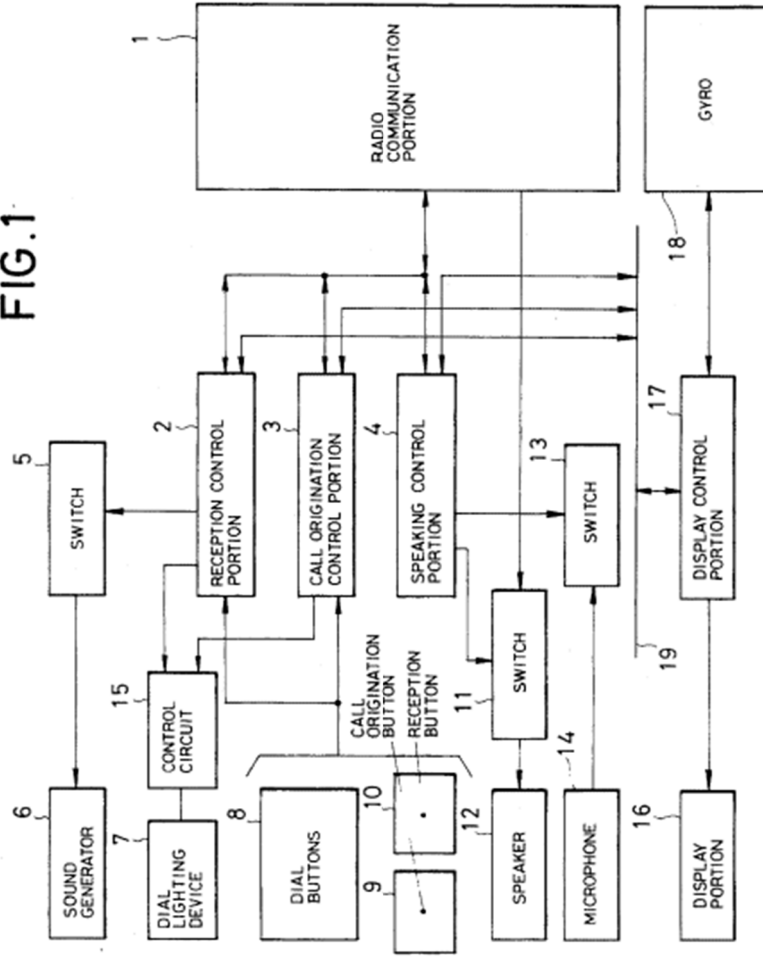

Miyashita at Fig. 1.

"The gyro 18 detects an inclination of a main body the portable telephone set to provide information concerning an inclination angle to the display control portion 17.

The display control portion 17 receives the inclination angle information from the gyro 18. The display control portion 17 is responsive to the inclination angle information indicative of a substantially horizontal orientation of the main body and to one of reception control command from the reception control portion 2 and a call origination control command from the call origination control portion 3, to control a power source to supply a power to the display portion 16.

In contrast, the display control portion 17 is responsive to the inclination angle information indicative of variation of the inclination angle from the substantially horizontal orientation to the substantially vertical orientation while it performs display control for the display portion 16 to display the control information, to terminate the power supply for the display portion 16.” Miyashita at 3:46-64.

“In FIG. 2 when the dial buttons 8 of the portable telephone set are to be operated, the main body 20 should be held in substantially horizontal orientation, directing dial buttons 8 and the display portion 16 upwardly.

At this condition, when dial buttons 8, call origination button 9 and reception button 10 are selectively depressed, connection to the remote terminal is established for enabling speaking. During speaking, the main body 20 is held in substantially vertical orientation. The orientations of the main body 20 as illustrated in FIGS. 2 and 3, are detected by the gyro 18 and the inclination angle information is input to the display control portion 17, as set forth above.

Therefore, as set forth above, the display control portion 17 performs the power supply control so the power is supplied to the display portion 16 when the main body is placed at the substantially horizontal orientation as detected by the gyro 18. On the other hand, when the gyro 18 detects the fact that the main body is placed at substantially vertical orientation, the display control portion 17 shut down the power supply for the display portion 16.” Miyashita at 4:9-29.

“It should be appreciated that the wording “substantially horizontal orientation” as defined throughout the disclosure represents the position of the main body where the dial button array, call origination button, reception button and display portion face toward the user’s face, which may not be necessarily exactly horizontal, but instead is over relatively wider range of orientation; and the wording “substantially vertical orientation” as defined throughout the disclosure represents the position of the main body where the dial button array, call origination button, reception button and display portion are placed substantially perpendicular to the plane facing with the user’s face, which is not necessarily exactly vertical but instead is over a relatively wide range but the position where the speaker is placed in opposition to the user’s ear and the microphone is placed in the vicinity of the user’s mouth.” Miyashita at 4:46-61.

To the extent Miyashita is deemed to not expressly disclose “a proximity sensor adapted to generate a signal indicative of proximity of an external object,” Miyashita inherently discloses this limitation. Miyashita discloses a gyro that indicates the inclination angle (vertical vs. horizontal) of the mobile station for the purpose of indicating whether a user is likely looking or not looking at the display of the mobile station and/or talking on the mobile station. *See* Miyashita at 3:46-4:2 (“The gyro 18 detects an inclination of a main body the portable telephone set to provide information concerning an inclination angle to the display control portion 17. The display control portion 17 receives the inclination angle information from the gyro 18. The display control portion 17 is responsive to the inclination angle information indicative of a substantially horizontal orientation of the main body and to one of reception control command from the reception control portion 2 and a call origination control command from the call origination control portion 3, to control a power source to supply a power to the display portion 16. In contrast, the display control portion 17 is responsive to the inclination angle information indicative of variation of the inclination angle from the substantially horizontal orientation to the substantially vertical orientation while it performs display control for the display portion 16 to display the control information, to terminate the power supply for the display portion 16. When speaking is performed

with the destination person via the speaker 12 and the microphone 14, it is rare to require seeing the display content on the display portion 16. Therefore, the power supply for the display portion 16 is shut down. Thus, exhausting of a battery can be reduced.’). A person of ordinary skill in the art at the time of the alleged invention would have understood that various sensors can be used in a mobile station for the purpose of indicating whether a user is likely looking or not looking at the display of the mobile station and/or talking on the mobile station. *See, e.g.,* Perez at ¶ 0022 (“[T]he step of detecting a talk condition can be achieved by monitoring or detecting at least one among the conditions of a) detecting if a predetermined volume of acoustic sound is being received at a microphone indicative of a user talking on the portable communication device; b) measuring at least one among a spectrum density and a spectrum energy of a bounced signal to determine the proximity of a user’s head to an earpiece of the portable communication device; c) measuring a predetermined period after a phone call starts; d) detecting an angle at which the portable communication device is positioned; e) detecting a vibration of the portable communication device; or f) detecting if the portable communication device is in a user’s hand. How the method 50 can detect the conditions described above can be embodied in many different forms using individually or in combination sensors and timers and other devices’). A person of ordinary skill in the art at the time of the alleged invention would therefore have understood that the invention of Miyashita could be performed using a “a proximity sensor adapted to generate a signal indicative of proximity of an external object” for the purpose of indicating whether a user is likely looking or not looking at the display of the mobile station and/or talking on the mobile station. Miyashita therefore necessarily discloses “a proximity sensor adapted to generate a signal indicative of proximity of an external object.”

To the extent Miyashita is deemed to not expressly or inherently disclose “a proximity sensor adapted to generate a signal indicative of proximity of an external object,” Miyashita renders it obvious to one of ordinary skill in the art at the time of the alleged invention to use “a proximity sensor adapted to generate a signal indicative of proximity of an external object.” Miyashita discloses a gyro that indicates the inclination angle (vertical vs. horizontal) of the mobile station for the purpose of

indicating whether a user is likely looking or not looking at the display of the mobile station and/or talking on the mobile station. *See* Miyashita at 3:46-4:2 (“The gyro 18 detects an inclination of a main body the portable telephone set to provide information concerning an inclination angle to the display control portion 17. The display control portion 17 receives the inclination angle information from the gyro 18. The display control portion 17 is responsive to the inclination angle information indicative of a substantially horizontal orientation of the main body and to one of reception control command from the reception control portion 2 and a call origination control command from the call origination control portion 3, to control a power source to supply a power to the display portion 16. In contrast, the display control portion 17 is responsive to the inclination angle information indicative of variation of the inclination angle from the substantially horizontal orientation to the substantially vertical orientation while it performs display control for the display portion 16 to display the control information, to terminate the power supply for the display portion 16. When speaking is performed with the destination person via the speaker 12 and the microphone 14, it is rare to require seeing the display content on the display portion 16. Therefore, the power supply for the display portion 16 is shut down. Thus, exhausting of a battery can be reduced.”). A person of ordinary skill in the art at the time of the alleged invention would have understood that various sensors can be used in a mobile station for the purpose of indicating whether a user is likely looking or not looking at the display of the mobile station and/or talking on the mobile station. *See, e.g.,* Perez at ¶ 0022 (“[T]he step of detecting a talk condition can be achieved by monitoring or detecting at least one among the conditions of a) detecting if a predetermined volume of acoustic sound is being received at a microphone indicative of a user talking on the portable communication device; b) measuring at least one among a spectrum density and a spectrum energy of a bounced signal to determine the proximity of a user’s head to an earpiece of the portable communication device; c) measuring a predetermined period after a phone call starts; d) detecting an angle at which the portable communication device is positioned; e) detecting a vibration of the portable communication device; or f) detecting if the portable communication device is in a user’s hand. How the method 50 can detect the conditions described above can be embodied in many different forms using individually or in combination sensors and timers and other devices”). A person of ordinary skill in the art at the time of the alleged invention would therefore have understood that the invention of Miyashita could be performed using a “a proximity

sensor adapted to generate a signal indicative of proximity of an external object' for the purpose of indicating whether a user is likely looking or not looking at the display of the mobile station and/or talking on the mobile station. Doing so would be a design choice driven by a number of different reasons and would be within the knowledge and ability of a person of ordinary skill in the art at the time of the alleged invention. This combination would constitute, at least, combining prior art elements according to known methods to yield predictable results, a simple substitution of one known element for another to obtain predictable results, the use of a known technique to improve similar devices in the same way, the application of a known technique to a known device ready for improvement to yield a predictable result, and obvious to try.

To the extent Miyashita is deemed to not expressly or inherently disclose "a proximity sensor adapted to generate a signal indicative of proximity of an external object," it would be obvious to combine the disclosure of Miyashita with those of Numazawa as described in the Numazawa claim chart, which is incorporated herein in its entirety by reference. Miyashita and Numazawa are both directed to conserving battery power in mobile stations generally and more particularly at conserving battery power in mobile stations by using sensors to detect when the user of the mobile station is in a call and unlikely to be looking at the display (as when, for example, the proximity sensor detects the user's ear by the mobile station or a sensor detects that the mobile station is in a vertical orientation) and to power off the display of mobile stations at such times. Miyashita at 1:58-63 ("The present invention is directed to solving the problem set forth above. It is therefore an object of the present invention to provide a portable telephone set which can shut off the power supply for a display portion while a content of the display will not be seen during speaking, and thus can reduce power consumption."), 2:6-11 ("In the preferred construction the detector is a gyro. The control apparatus may shut off the power supply for the display when the detector detects the main body at a substantially vertical position. On the other hand, the control may initiate power supply for the display when the detector detects the main body at a substantially horizontal position."); Numazawa at ¶ Abstract ("To achieve reduced power consumption through stopping operation of unnecessary functions during use of a wireless terminal. A CPU 2 identifies start of a call state through a signal

from a signal processing portion 3 for controlling communication with a base station, and identifies, through an output signal from detecting means 6, whether or not a user ear is in contact with a terminal. Upon identification of contact of the ear to the terminal, controlling means 8 are caused to stop the supply of electric power, from a power supply 7, to displaying means 9 for providing information to a user, and lighting means 10, such as a black light.”), ¶ 0005-0007 (“In the present invention, control is such that, upon determination that the wireless terminal is in a call, operation of functions believe be unnecessary, due to the user of the terminal being in a call, is stopped, and upon termination of the call, operation of the stopped functions is restarted. Additionally, because it is envisioned that there will also be cases where, even during a call, the face of the user may be separated from the receiver of the terminal, control is performed so as to enable restarting of the operations of the functions that had been stopped as unnecessary, through detecting whether or not the user of the terminal has the receiver in contact with an ear. The achievement of reduced power consumption through stopping operation of functions that become unnecessary in use of the terminal, as described above, can be anticipated to have the effect of extending the life of the power supply, such as a battery.’). A person of ordinary skill in the art at the time of the alleged invention would be motivated to modify Miyashita to use “a proximity sensor adapted to generate a signal indicative of proximity of an external object,” as disclosed in Numazawa for a number of different reasons, including that it would support Miyashita’s ability to conserve battery power in mobile stations, and doing so would be within the knowledge and ability of a person of ordinary skill in the art at the time of the alleged invention. The combination would constitute, at least, combining prior art elements according to known methods to yield predictable results, a simple substitution of one known element for another to obtain predictable results, the use of a known technique to improve similar devices in the same way, the application of a known technique to a known device ready for improvement to yield a predictable result, and obvious to try.

To the extent Miyashita is deemed to not expressly or inherently disclose “a proximity sensor adapted to generate a signal indicative of proximity of an external object,” it would be obvious to combine the disclosure of Miyashita with those of Perez as

described in the Perez claim chart, which is incorporated herein in its entirety by reference. Miyashita and Perez are both directed to conserving battery power in mobile stations generally and more particularly at conserving battery power in mobile stations by using sensors to detect when the user of the mobile station is in a call and unlikely to be looking at the display (as when, for example, the proximity sensor detects the user's ear by the mobile station or a sensor detects that the mobile station is in a vertical orientation) and to power off the display of mobile stations at such times. Miyashita at 1:58-63 ("The present invention is directed to solving the problem set forth above. It is therefore an object of the present invention to provide a portable telephone set which can shut off the power supply for a display portion while a content of the display will not be seen during speaking, and thus can reduce power consumption."), 2:6-11 ("In the preferred construction the detector is a gyro. The control apparatus may shut off the power supply for the display when the detector detects the main body at a substantially vertical position. On the other hand, the control may initiate power supply for the display when the detector detects the main body at a substantially horizontal position."); Perez at ¶ 0013 ("Referring to FIG. 1, a portable communication product 10 such as a cellular phone includes a transceiver radio having a microphone 20, an earpiece 22, a keypad 18 and a display 12 (such as a color display) coupled to the transceiver radio. The portable communication product 10 further includes at least one sensor (24, 26, 28 or 30) and a processor 16. The sensor can be used for detecting a user condition of the portable communication device such as a talk condition when the user is assumed to be talking on the portable communication device. The processor 16 can be programmed to at least reduce power provided to the display 12 when the sensor detects the talk condition. The processor 16 can also turn off power to the display 12 during a talk condition if desired."). A person of ordinary skill in the art at the time of the alleged invention would be motivated to modify Miyashita to use "a proximity sensor adapted to generate a signal indicative of proximity of an external object," as disclosed in Perez for a number of different reasons, including that it would support Miyashita's ability to conserve battery power in mobile stations, and doing so would be within the knowledge and ability of a person of ordinary skill in the art at the time of the alleged invention. The combination would constitute, at least, combining prior art elements according to known methods to yield predictable results, a simple substitution of one known element for another to obtain predictable results, the use of a known technique to improve similar devices in the same way, the application of a

known technique to a known device ready for improvement to yield a predictable result, and obvious to try.

To the extent Miyashita is deemed to not expressly or inherently disclose “a proximity sensor adapted to generate a signal indicative of proximity of an external object,” it would be obvious to combine the disclosure of Miyashita with those of Seo as described in the Seo claim chart, which is incorporated herein in its entirety by reference. Miyashita and Seo are both directed to conserving battery power in mobile stations generally and more particularly at conserving battery power in mobile stations by using sensors to detect when the user of the mobile station is in a call and unlikely to be looking at the display (as when, for example, the proximity sensor detects the user’s ear by the mobile station or a sensor detects that the mobile station is in a vertical orientation) and to power off the display of mobile stations at such times. Miyashita at 1:58-63 (“The present invention is directed to solving the problem set forth above. It is therefore an object of the present invention to provide a portable telephone set which can shut off the power supply for a display portion while a content of the display will not be seen during speaking, and thus can reduce power consumption.”), 2:6-11 (“In the preferred construction the detector is a gyro. The control apparatus may shut off the power supply for the display when the detector detects the main body at a substantially vertical position. On the other hand, the control may initiate power supply for the display when the detector detects the main body at a substantially horizontal position.”); Seo at 1:36-42 (“It is hence a primary object of the invention to present a novel cordless telephone capable of, by solving the above mentioned technical problems, stopping the display action by the display device while the handset is in service so as to minimize the wasteful consumption of the electric power supplied from the battery or the like.”), 3:64-4:5 (When the receiver 6 is not in contact with the user’s ear, the light emitting element 3 lights up at step n8. In this state, when the user touches the receiver 6 of the handset by the ear, it is detected by the piezoelectric element 7, and the detection signal is sent out to the control circuit 11. The control circuit 11, on the basis of this detection signal, sends out a stop signal to the driver 12. Thus, driving of the driver 12 is stopped, and the light emitting element 3 is extinguished at step n7.”). A person of ordinary skill in the art at the time of the

	<p>alleged invention would be motivated to modify Miyashita to use “a proximity sensor adapted to generate a signal indicative of proximity of an external object,” as disclosed in Seo for a number of different reasons, including that it would support Miyashita’s ability to conserve battery power in mobile stations, and doing so would be within the knowledge and ability of a person of ordinary skill in the art at the time of the alleged invention. The combination would constitute, at least, combining prior art elements according to known methods to yield predictable results, a simple substitution of one known element for another to obtain predictable results, the use of a known technique to improve similar devices in the same way, the application of a known technique to a known device ready for improvement to yield a predictable result, and obvious to try.</p>
<p>[1c] a microprocessor adapted to:</p>	<p>Miyashita discloses a microprocessor:</p> <p>For example:</p> <p>“FIG. 1 is a block diagram showing a construction of one embodiment of the portable telephone set according to the present invention. FIG. 1, encompasses one embodiment of the portable telephone set according to the invention with substantially the same construction as FIG. 4 except for a display portion 16, a display control portion 17 and a gyro 18 as additional components.” Miyashita at 3:27-33.</p>

FIG. 1

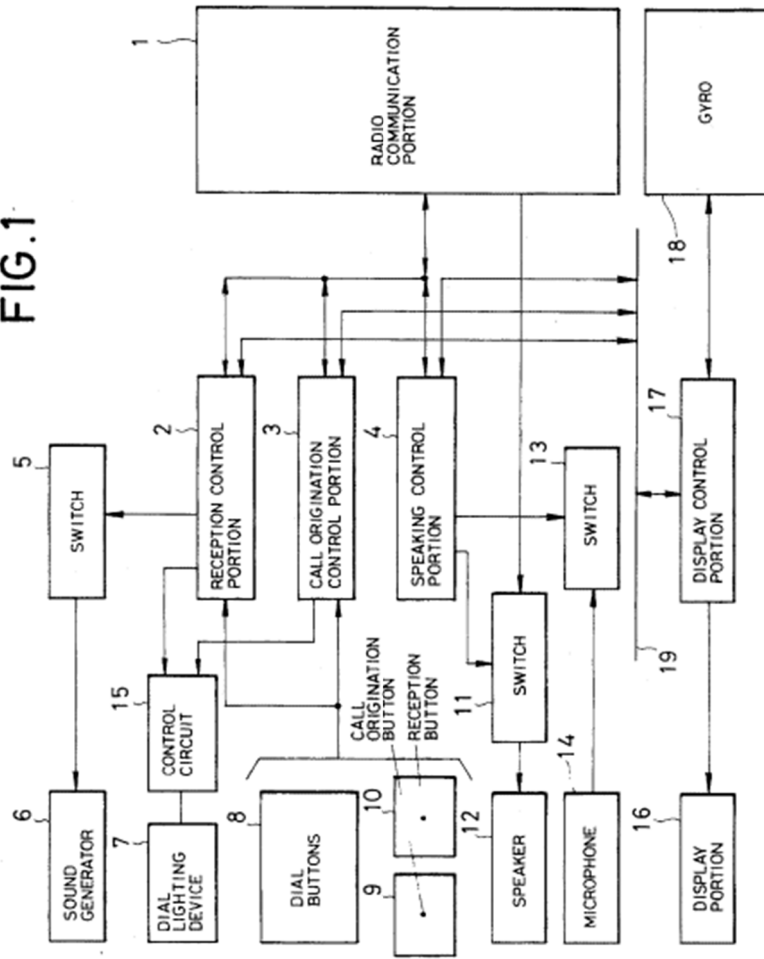

Miyashita at Fig. 1.

“The display control portion 17 is connected to a reception control portion 2, a call origination control portion 3 and a speaking control portion 4, respectively, via a common path 19. Control information associated with speaking is displayed on the display portion 16. On the other hand, the display control portion 17 also controls power supply for the display portion 16.” Miyashita at 3:39-46.

To the extent Miyashita is deemed to not expressly disclose a “microprocessor adapted to,” Miyashita inherently discloses this limitation. Miyashita discloses a mobile telephone with a display control portion 17, reception control portion 2, a call origination control portion 3 and a speaking control portion 4. Microprocessors (such as the ARM7TDMI) were widely implemented in mobile stations at the time of the alleged invention to control functionality within the mobile station. *See, e.g., S. Segars, “The ARM9 family-high performance microprocessors for embedded applications”, Proc. ICCD, pp. 230-235, 1998-Oct.* A person of ordinary skill in the art at the time of the alleged invention would therefore understand Miyashita to necessarily disclose a “microprocessor adapted to.”

To the extent Miyashita is deemed to not expressly or inherently disclose “a microprocessor,” Miyashita renders it obvious to one of skill in the art to use “a microprocessor.” A person of ordinary skill in the art at the time of the alleged invention would understand that the functionality of display control portion 17, reception control portion 2, a call origination control portion 3 and a speaking control portion 4 could be implemented using a microprocessor such as the ARM7TDMI. *See, e.g., S. Segars, “The ARM9 family-high performance microprocessors for embedded applications”, Proc. ICCD, pp. 230-235, 1998-Oct.* Doing so would be a design choice driven by a number of different reasons, including that it would support Miyashita’s ability to conserve battery power in mobile stations, and doing so would be within the knowledge and ability of a person of ordinary skill in the art at the time of the alleged invention. The use of a microprocessor would constitute, at least, combining prior art elements according to known methods to yield predictable results, a simple substitution of one known element for another to obtain predictable results, the use of a known technique to improve similar devices in the same way, the application of a known technique to a known device ready for improvement to yield a predictable result, and obvious to try.

To the extent Miyashita is deemed to not expressly or inherently disclose “a microprocessor adapted to,” it would be obvious to combine the disclosure of Miyashita with those of Numazawa as described in the Numazawa claim chart, which is incorporated herein in its entirety by reference. Miyashita and Numazawa are both directed to conserving battery power in mobile stations generally and more particularly at conserving battery power in mobile stations by using sensors to detect when the user of the mobile station is in a call and unlikely to be looking at the display (as when, for example, the proximity sensor detects the user’s ear by the mobile station or a sensor detects that the mobile station is in a vertical orientation) and to power off the display of mobile stations at such times. Miyashita at 1:58-63 (“The present invention is directed to solving the problem set forth above. It is therefore an object of the present invention to provide a portable telephone set which can shut off the power supply for a display portion while a content of the display will not be seen during speaking, and thus can reduce power consumption.”), 2:6-11 (“In the preferred construction the detector is a gyro. The control apparatus may shut off the power supply for the display when the detector detects the main body at a substantially vertical position. On the other hand, the control may initiate power supply for the display when the detector detects the main body at a substantially horizontal position.”); Numazawa at ¶ Abstract (“To achieve reduced power consumption through stopping operation of unnecessary functions during use of a wireless terminal. A CPU 2 identifies start of a call state through a signal from a signal processing portion 3 for controlling communication with a base station, and identifies, through an output signal from detecting means 6, whether or not a user ear is in contact with a terminal. Upon identification of contact of the ear to the terminal, controlling means 8 are caused to stop the supply of electric power, from a power supply 7, to displaying means 9 for providing information to a user, and lighting means 10, such as a black light.”), ¶ 0005-0007 (“In the present invention, control is such that, upon determination that the wireless terminal is in a call, operation of functions believe be unnecessary, due to the user of the terminal being in a call, is stopped, and upon termination of the call, operation of the stopped functions is restarted. Additionally, because it is envisioned that there will also be cases where, even during a call, the face of the user may be separated from the receiver of the terminal, control is performed so as to enable restarting of the operations of the functions that had been stopped as unnecessary, through detecting whether or not the user of the terminal has the receiver in contact with an ear. The achievement of reduced power

consumption through stopping operation of functions that become unnecessary in use of the terminal, as described above, can be anticipated to have the effect of extending the life of the power supply, such as a battery.”). A person of ordinary skill in the art at the time of the alleged invention would be motivated to modify Miyashita to use “a microprocessor adapted to” as disclosed in Numazawa for a number of different reasons, including that it would support Miyashita’s ability to conserve battery power in mobile stations, and doing so would be within the knowledge and ability of a person of ordinary skill in the art at the time of the alleged invention. The combination would constitute, at least, combining prior art elements according to known methods to yield predictable results, a simple substitution of one known element for another to obtain predictable results, the use of a known technique to improve similar devices in the same way, the application of a known technique to a known device ready for improvement to yield a predictable result, and obvious to try.

To the extent Miyashita is deemed to not expressly or inherently disclose “a microprocessor adapted to” it would be obvious to combine the disclosure of Miyashita with those of Perez as described in the Perez claim chart, which is incorporated herein in its entirety by reference. Miyashita and Perez are both directed to conserving battery power in mobile stations generally and more particularly at conserving battery power in mobile stations by using sensors to detect when the user of the mobile station is in a call and unlikely to be looking at the display (as when, for example, the proximity sensor detects the user’s ear by the mobile station or a sensor detects that the mobile station is in a vertical orientation) and to power off the display of mobile stations at such times. Miyashita at 1:58-63 (“The present invention is directed to solving the problem set forth above. It is therefore an object of the present invention to provide a portable telephone set which can shut off the power supply for a display portion while a content of the display will not be seen during speaking, and thus can reduce power consumption.”), 2:6-11 (“In the preferred construction the detector is a gyro. The control apparatus may shut off the power supply for the display when the detector detects the main body at a substantially vertical position. On the other hand, the control may initiate power supply for the display when the detector detects the main body at a substantially horizontal position.”); Perez at ¶ 0013 (“Referring to FIG.

1, a portable communication product 10 such as a cellular phone includes a transceiver radio having a microphone 20, an earpiece 22, a keypad 18 and a display 12 (such as a color display) coupled to the transceiver radio. The portable communication product 10 further includes at least one sensor (24, 26, 28 or 30) and a processor 16. The sensor can be used for detecting a user condition of the portable communication device such as a talk condition when the user is assumed to be talking on the portable communication device. The processor 16 can be programmed to at least reduce power provided to the display 12 when the sensor detects the talk condition. The processor 16 can also turn off power to the display 12 during a talk condition if desired.’). A person of ordinary skill in the art at the time of the alleged invention would be motivated to modify Miyashita to use “a microprocessor adapted to” as disclosed in Perez for a number of different reasons, including that it would support Miyashita’s ability to conserve battery power in mobile stations, and doing so would be within the knowledge and ability of a person of ordinary skill in the art at the time of the alleged invention. The combination would constitute, at least, combining prior art elements according to known methods to yield predictable results, a simple substitution of one known element for another to obtain predictable results, the use of a known technique to improve similar devices in the same way, the application of a known technique to a known device ready for improvement to yield a predictable result, and obvious to try.

To the extent Miyashita is deemed to not expressly or inherently disclose “a proximity sensor adapted to generate a signal indicative of proximity of an external object,” it would be obvious to combine the disclosure of Miyashita with those of Seo as described in the Seo claim chart, which is incorporated herein in its entirety by reference. Miyashita and Seo are both directed to conserving battery power in mobile stations generally and more particularly at conserving battery power in mobile stations by using sensors to detect when the user of the mobile station is in a call and unlikely to be looking at the display (as when, for example, the proximity sensor detects the user’s ear by the mobile station or a sensor detects that the mobile station is in a vertical orientation) and to power off the display of mobile stations at such times. Miyashita at 1:58-63 (“The present invention is directed to solving the problem set forth above. It is therefore an object of the present invention to provide a portable telephone set which

	<p>can shut off the power supply for a display portion while a content of the display will not be seen during speaking, and thus can reduce power consumption.”), 2:6-11 (“In the preferred construction the detector is a gyro. The control apparatus may shut off the power supply for the display when the detector detects the main body at a substantially vertical position. On the other hand, the control may initiate power supply for the display when the detector detects the main body at a substantially horizontal position.”); Seo at 1:36-42 (“It is hence a primary object of the invention to present a novel cordless telephone capable of, by solving the above mentioned technical problems, stopping the display action by the display device while the handset is in service so as to minimize the wasteful consumption of the electric power supplied from the battery or the like.”), 3:64-4:5 (When the receiver 6 is not in contact with the user’s ear, the light emitting element 3 lights up at step n8. In this state, when the user touches the receiver 6 of the handset by the ear, it is detected by the piezoelectric element 7, and the detection signal is sent out to the control circuit 11. The control circuit 11, on the basis of this detection signal, sends out a stop signal to the driver 12. Thus, driving of the driver 12 is stopped, and the light emitting element 3 is extinguished at step n7.”). A person of ordinary skill in the art at the time of the alleged invention would be motivated to modify Miyashita to use “a microprocessor adapted to” as disclosed in Seo for a number of different reasons, including that it would support Miyashita’s ability to conserve battery power in mobile stations, and doing so would be within the knowledge and ability of a person of ordinary skill in the art at the time of the alleged invention. The combination would constitute, at least, combining prior art elements according to known methods to yield predictable results, a simple substitution of one known element for another to obtain predictable results, the use of a known technique to improve similar devices in the same way, the application of a known technique to a known device ready for improvement to yield a predictable result, and obvious to try.</p>
<p>[1d] (a) determine whether a telephone call is active;</p>	<p>Miyashita discloses the microprocessor adapted to determine whether a telephone call is active:</p> <p>For example:</p>

“For a portable telephone set having a display portion for displaying various information associated with call or origination and reception, a gyro for detecting inclination of a main body is provided.” Miyashita at Abstract.

“FIG. 1 is a block diagram showing a construction of one embodiment of the portable telephone set according to the present invention. FIG. 1, encompasses one embodiment of the portable telephone set according to the invention with substantially the same construction as FIG. 4 except for a display portion 16, a display control portion 17 and a gyro 18 as additional components.” Miyashita at 3:27-33.

FIG. 1

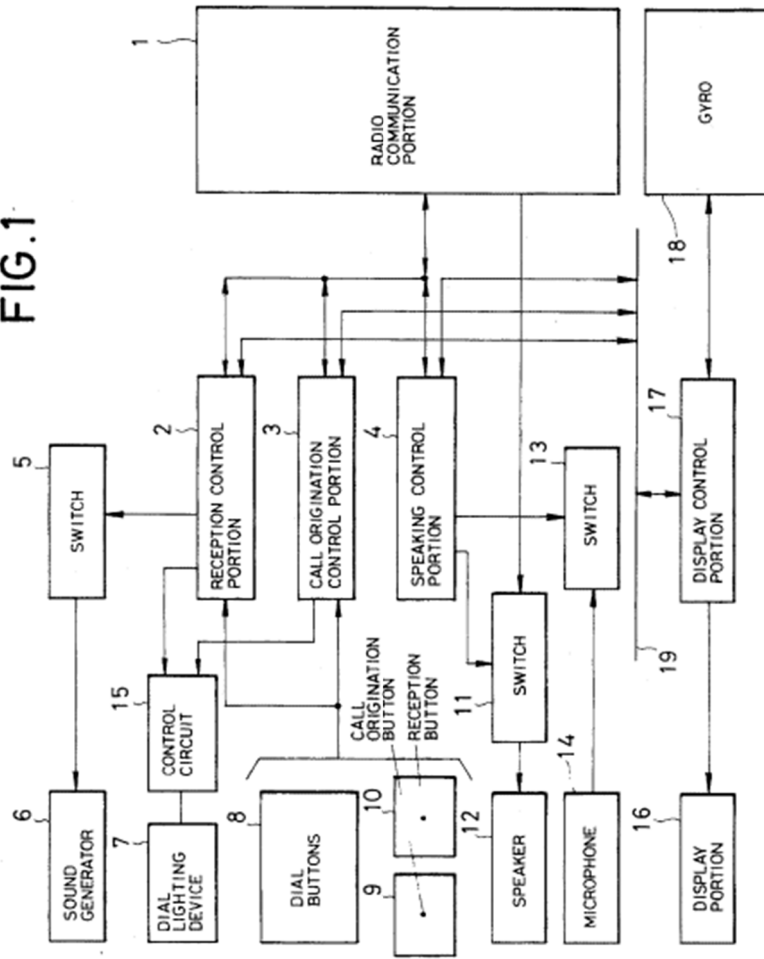

Miyashita at Fig. 1.

“The display control portion 17 is connected to a reception control portion 2, a call origination control portion 3 and a speaking control portion 4, respectively, via a common path 19. Control information associated with speaking is displayed on the display portion 16. On the other hand, the display control portion 17 also controls power supply for the display portion 16.” Miyashita at 3:39-46.

“The display control portion 17 is responsive to the inclination angle information indicative of a substantially horizontal orientation of the main body and to one of reception control command from the reception control portion 2 and a call origination control command from the call origination control portion 3, to control a power source to supply a power to the display portion 16.” Miyashita at 3:51-56.

“In FIG. 2 when the dial buttons 8 of the portable telephone set are to be operated, the main body 20 should be held in substantially horizontal orientation, directing dial buttons 8 and the display portion 16 upwardly.

At this condition, when dial buttons 8, call origination button 9 and reception button 10 are selectively depressed, connection to the remote terminal is established for enabling speaking. During speaking, the main body 20 is held in substantially vertical orientation.” Miyashita at 4:9-17.

“Thus, according to the shown embodiment, when the inclination angle information indicative that the main body is in a substantially horizontal orientation and when the reception control command from the reception control portion 2 and the call origination control command from the call origination control portion 3, the display control portion 17 starts the supply of the power. “Miyashita at 4:30-36.

To the extent Miyashita is deemed to not expressly disclose the microprocessor adapted to “determine whether a telephone call is active,” Miyashita inherently discloses this limitation. Miyashita specifies that the display control portion 17 can shut off power to the display portion 16 in response to inclination angle information from the gyro 18 that indicates a vertical orientation for the portable telephone set, only “[a]fter speaking is star[t]ed.” See Miyashita at 4:21-45. A person of ordinary skill in the art at the time of the alleged invention would therefore understand that, in order for the portable telephone set to determine whether “speaking is started” it must necessarily

“determine[s] whether a telephone call is active.” Further as noted above for element [1c] and incorporated by reference here, Miyashita discloses or renders obvious the use of a microprocessor. Therefore, a person of ordinary skill in the art at the time of the alleged invention would understand that necessarily the microprocessor would “determine whether a telephone call is active.”

To the extent Miyashita is deemed to not expressly disclose the microprocessor adapted to “determine whether a telephone call is active,” Miyashita renders this limitation obvious to one of ordinary skill in the art at the time of the alleged invention. Miyashita specifies that the display control portion 17 can shut off power to the display portion 16 in response to inclination angle information from the gyro 18 that indicates a vertical orientation for the portable telephone set, only “[a]fter speaking is star[t]ed.” See Miyashita at 4:21-45. Further as noted above for element [1c] and incorporated by reference here, Miyashita discloses or renders obvious the use of a microprocessor. A person of ordinary skill in the art at the time of the alleged invention would find it obvious to implement the microprocessor of Miyashita to determine whether the “speaking is started.” Doing so would be a design choice driven by a number of different reasons, including that it would support Miyashita’s ability to conserve battery power in mobile stations, and doing so would be within the knowledge and ability of a person of ordinary skill in the art at the time of the alleged invention. Doing so would also constitute, at least, combining prior art elements according to known methods to yield predictable results, a simple substitution of one known element for another to obtain predictable results, the use of a known technique to improve similar devices in the same way, the application of a known technique to a known device ready for improvement to yield a predictable result, and obvious to try.

To the extent Miyashita is deemed to not expressly or inherently disclose a microprocessor adapted to “determine whether a telephone call is active,” it would be obvious to combine the disclosure of Miyashita with those of Numazawa as described

in the Numazawa claim chart, which is incorporated herein in its entirety by reference. Miyashita and Numazawa are both directed to conserving battery power in mobile stations generally and more particularly at conserving battery power in mobile stations by using sensors to detect when the user of the mobile station is in a call and unlikely to be looking at the display (as when, for example, the proximity sensor detects the user's ear by the mobile station or a sensor detects that the mobile station is in a vertical orientation) and to power off the display of mobile stations at such times. Miyashita at 1:58-63 ("The present invention is directed to solving the problem set forth above. It is therefore an object of the present invention to provide a portable telephone set which can shut off the power supply for a display portion while a content of the display will not be seen during speaking, and thus can reduce power consumption."), 2:6-11 ("In the preferred construction the detector is a gyro. The control apparatus may shut off the power supply for the display when the detector detects the main body at a substantially vertical position. On the other hand, the control may initiate power supply for the display when the detector detects the main body at a substantially horizontal position."); Numazawa at ¶ Abstract ("To achieve reduced power consumption through stopping operation of unnecessary functions during use of a wireless terminal. A CPU 2 identifies start of a call state through a signal from a signal processing portion 3 for controlling communication with a base station, and identifies, through an output signal from detecting means 6, whether or not a user ear is in contact with a terminal. Upon identification of contact of the ear to the terminal, controlling means 8 are caused to stop the supply of electric power, from a power supply 7, to displaying means 9 for providing information to a user, and lighting means 10, such as a black light."), ¶ 0005-0007 ("In the present invention, control is such that, upon determination that the wireless terminal is in a call, operation of functions believe be unnecessary, due to the user of the terminal being in a call, is stopped, and upon termination of the call, operation of the stopped functions is restarted. Additionally, because it is envisioned that there will also be cases where, even during a call, the face of the user may be separated from the receiver of the terminal, control is performed so as to enable restarting of the operations of the functions that had been stopped as unnecessary, through detecting whether or not the user of the terminal has the receiver in contact with an ear. The achievement of reduced power consumption through stopping operation of functions that become unnecessary in use of the terminal, as described above, can be anticipated to have the effect of extending the life of the power supply,

such as a battery.”). A person of ordinary skill in the art at the time of the alleged invention would be motivated to modify Miyashita to use a microprocessor adapted to “determine whether a telephone call is active,” as disclosed in Numazawa for a number of different reasons, including that it would support Miyashita’s ability to conserve battery power in mobile stations, and doing so would be within the knowledge and ability of a person of ordinary skill in the art at the time of the alleged invention. The combination would constitute, at least, combining prior art elements according to known methods to yield predictable results, a simple substitution of one known element for another to obtain predictable results, the use of a known technique to improve similar devices in the same way, the application of a known technique to a known device ready for improvement to yield a predictable result, and obvious to try.

To the extent Miyashita is deemed to not expressly or inherently disclose a microprocessor adapted to “determine whether a telephone call is active,” it would be obvious to combine the disclosure of Miyashita with those of Perez as described in the Perez claim chart, which is incorporated herein in its entirety by reference. Miyashita and Perez are both directed to conserving battery power in mobile stations generally and more particularly at conserving battery power in mobile stations by using sensors to detect when the user of the mobile station is in a call and unlikely to be looking at the display (as when, for example, the proximity sensor detects the user’s ear by the mobile station or a sensor detects that the mobile station is in a vertical orientation) and to power off the display of mobile stations at such times. Miyashita at 1:58-63 (“The present invention is directed to solving the problem set forth above. It is therefore an object of the present invention to provide a portable telephone set which can shut off the power supply for a display portion while a content of the display will not be seen during speaking, and thus can reduce power consumption.”), 2:6-11 (“In the preferred construction the detector is a gyro. The control apparatus may shut off the power supply for the display when the detector detects the main body at a substantially vertical position. On the other hand, the control may initiate power supply for the display when the detector detects the main body at a substantially horizontal position.”); Perez at ¶ 0013 (“Referring to FIG. 1, a portable communication product 10 such as a cellular phone includes a transceiver radio having a microphone 20, an

earpiece 22, a keypad 18 and a display 12 (such as a color display) coupled to the transceiver radio. The portable communication product 10 further includes at least one sensor (24, 26, 28 or 30) and a processor 16. The sensor can be used for detecting a user condition of the portable communication device such as a talk condition when the user is assumed to be talking on the portable communication device. The processor 16 can be programmed to at least reduce power provided to the display 12 when the sensor detects the talk condition. The processor 16 can also turn off power to the display 12 during a talk condition if desired.”). A person of ordinary skill in the art at the time of the alleged invention would be motivated to modify Miyashita to use a microprocessor adapted to “determine whether a telephone call is active,” as disclosed in Perez for a number of different reasons, including that it would support Miyashita’s ability to conserve battery power in mobile stations, and doing so would be within the knowledge and ability of a person of ordinary skill in the art at the time of the alleged invention. The combination would constitute, at least, combining prior art elements according to known methods to yield predictable results, a simple substitution of one known element for another to obtain predictable results, the use of a known technique to improve similar devices in the same way, the application of a known technique to a known device ready for improvement to yield a predictable result, and obvious to try.

To the extent Miyashita is deemed to not expressly or inherently disclose a microprocessor adapted to “determine whether a telephone call is active,” it would be obvious to combine the disclosure of Miyashita with those of Seo as described in the Seo claim chart, which is incorporated herein in its entirety by reference. Miyashita and Seo are both directed to conserving battery power in mobile stations generally and more particularly at conserving battery power in mobile stations by using sensors to detect when the user of the mobile station is in a call and unlikely to be looking at the display (as when, for example, the proximity sensor detects the user’s ear by the mobile station or a sensor detects that the mobile station is in a vertical orientation) and to power off the display of mobile stations at such times. Miyashita at 1:58-63 (“The present invention is directed to solving the problem set forth above. It is therefore an object of the present invention to provide a portable telephone set which can shut off the power supply for a display portion while a content of the display will not be seen

	<p>during speaking, and thus can reduce power consumption.”), 2:6-11 (“In the preferred construction the detector is a gyro. The control apparatus may shut off the power supply for the display when the detector detects the main body at a substantially vertical position. On the other hand, the control may initiate power supply for the display when the detector detects the main body at a substantially horizontal position.”); Seo at 1:36-42 (“It is hence a primary object of the invention to present a novel cordless telephone capable of, by solving the above mentioned technical problems, stopping the display action by the display device while the handset is in service so as to minimize the wasteful consumption of the electric power supplied from the battery or the like.”), 3:64-4:5 (When the receiver 6 is not in contact with the user’s ear, the light emitting element 3 lights up at step n8. In this state, when the user touches the receiver 6 of the handset by the ear, it is detected by the piezoelectric element 7, and the detection signal is sent out to the control circuit 11. The control circuit 11, on the basis of this detection signal, sends out a stop signal to the driver 12. Thus, driving of the driver 12 is stopped, and the light emitting element 3 is extinguished at step n7.”). A person of ordinary skill in the art at the time of the alleged invention would be motivated to modify Miyashita to use a microprocessor adapted to “determine whether a telephone call is active,” as disclosed in Seo for a number of different reasons, including that it would support Miyashita’s ability to conserve battery power in mobile stations, and doing so would be within the knowledge and ability of a person of ordinary skill in the art at the time of the alleged invention. The combination would constitute, at least, combining prior art elements according to known methods to yield predictable results, a simple substitution of one known element for another to obtain predictable results, the use of a known technique to improve similar devices in the same way, the application of a known technique to a known device ready for improvement to yield a predictable result, and obvious to try.</p>
<p>[1e] (b) receive the signal from the proximity sensor; and</p>	<p>Miyashita discloses the microprocessor adapted to receive the signal from the proximity sensor:</p> <p>For example:</p>

See discussion of claim elements [1b] and [1c], *supra*, which are incorporated herein by reference.

“FIG. 1 is a block diagram showing a construction of one embodiment of the portable telephone set according to the present invention. FIG. 1, encompasses one embodiment of the portable telephone set according to the invention with substantially the same construction as FIG. 4 except for a display portion 16, a display control portion 17 and a gyro 18 as additional components.” Miyashita at 3:27-33.

FIG. 1

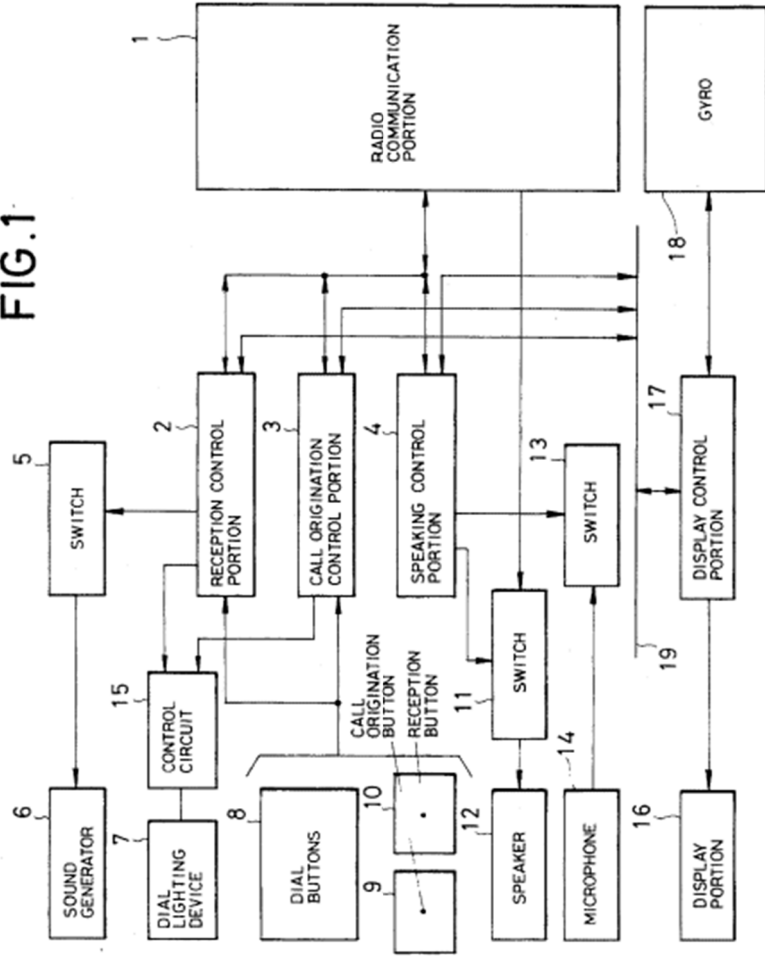

	<p>Miyashita at Fig. 1.</p> <p>“The gyro 18 detects an inclination of a main body the portable telephone set to provide information concerning an inclination angle to the display control portion 17. The display control portion 17 receives the inclination angle information from the gyro 18.” Miyashita at 3:46-64.</p> <p>“The orientations of the main body 20 as illustrated in FIGS. 2 and 3, are detected by the gyro 18 and the inclination angle information is input to the display control portion 17, as set forth above.”</p> <p>To the extent Miyashita is deemed to not expressly disclose a microprocessor adapted to “receive the signal from the proximity sensor,” Miyashita inherently discloses this limitation and/or renders obvious this limitation to one of ordinary skill in the art at the time of the alleged invention for the reasons discussed in claim elements [1b] and [1c], <i>supra</i>, which are incorporated herein by reference.</p>
<p>[1f] (c) reduce power to the display if (i) the microprocessor determines that a telephone call is active and (ii) the signal indicates the proximity of the external object; wherein:</p>	<p>Miyashita discloses the microprocessor adapted to reduce power to the display if (i) the microprocessor determines that a telephone call is active and (ii) the signal indicates the proximity of the external object:</p> <p>For example:</p> <p><i>See</i> discussions of claim elements [1b], [1d], [1e], <i>supra</i>, which are incorporated herein by reference.</p>

“According to another aspect of the invention, a portable telephone set comprises:
call origination control device responsive to a dialing operation for controlling call origination;

reception control apparatus responsive to reception of call for controlling reception;

display device for displaying information associated with call origination and reception;

a main body housing the call origination control, the reception control and the display;

detector apparatus for detecting inclination of the main body; and

control for controlling the power supply for the display, the control being responsive to the detector detecting a, substantially horizontal position of the main body for initiating power supply for the display.

The control may be responsive to the detector detecting a substantially vertical position for speaking after dialing operation, for shutting off the power supply for the display.”
Miyashita at 2:12-32.

“The display control portion 17 is connected to a reception control portion 2, a call origination control portion 3 and a speaking control portion 4, respectively, via a common path 19. Control information associated with speaking is displayed on the display portion 16. On the other hand, the display control portion 17 also controls power supply for the display portion 16.

The gyro 18 detects an inclination of a main body the portable telephone set to provide information concerning an inclination angle to the display control portion 17. The display control portion 17 receives the inclination angle information from the gyro 18. The display control portion 17 is responsive to the inclination angle information

indicative of a substantially horizontal orientation of the main body and to one of reception control command from the reception control portion 2 and a call origination control command from the call origination control portion 3, to control a power source to supply a power to the display portion 16.

In contrast, the display control portion 17 is responsive to the inclination angle information indicative of variation of the inclination angle from the substantially horizontal orientation to the substantially vertical orientation while it performs display control for the display portion 16 to display the control information, to terminate the power supply for the display portion 16.

When speaking is performed with the destination person via the speaker 12 and the microphone 14, it is rare to require seeing the display content on the display portion 16. Therefore, the power supply for the display portion 16 is shut down. Thus, exhausting of a battery can be reduced.” Miyashita at 3:39-4:2.

“Thus, according to the shown embodiment, when the inclination angle information indicative that the main body is in a substantially horizontal orientation and when the reception control command from the reception control portion 2 and the call origination control command from the call origination control portion 3, the display control portion 17 starts the supply of the power. After speaking is started, when the inclination angle information indicative of a variation of orientation of the main body from the horizontal position to the vertical position, the display control portion shuts off power supply for the display portion 16. Therefore, in the state of the portable telephone set in which the display portion 16 will not be seen, no power will be supplied to the display portion 16. Therefore, power consumption can be reduced. As well, it should serve for reducing the depletion of the battery.” Miyashita at 4:30-45.

To the extent Miyashita is deemed to not expressly or inherently disclose a microprocessor adapted to “reduce power to the display if (i) the microprocessor determines that a telephone call is active and (ii) the signal indicates the proximity of

the external object,” Miyashita renders it obvious to one of ordinary skill in the art at the time of the alleged invention. Miyashita discloses a gyro that indicates the inclination angle (vertical vs. horizontal) of the mobile station for the purpose of indicating whether a user is likely looking or not looking at the display of the mobile station and/or talking on the mobile station. *See* Miyashita at 3:46-4:2 (“The gyro 18 detects an inclination of a main body the portable telephone set to provide information concerning an inclination angle to the display control portion 17. The display control portion 17 receives the inclination angle information from the gyro 18. The display control portion 17 is responsive to the inclination angle information indicative of a substantially horizontal orientation of the main body and to one of reception control command from the reception control portion 2 and a call origination control command from the call origination control portion 3, to control a power source to supply a power to the display portion 16. In contrast, the display control portion 17 is responsive to the inclination angle information indicative of variation of the inclination angle from the substantially horizontal orientation to the substantially vertical orientation while it performs display control for the display portion 16 to display the control information, to terminate the power supply for the display portion 16. When speaking is performed with the destination person via the speaker 12 and the microphone 14, it is rare to require seeing the display content on the display portion 16. Therefore, the power supply for the display portion 16 is shut down. Thus, exhausting of a battery can be reduced.”). A person of ordinary skill in the art at the time of the alleged invention would have understood that various sensors can be used in a mobile station for the purpose of indicating whether a user is likely looking or not looking at the display of the mobile station and/or talking on the mobile station. *See, e.g.,* Perez at ¶ 0022 (“[T]he step of detecting a talk condition can be achieved by monitoring or detecting at least one among the conditions of a) detecting if a predetermined volume of acoustic sound is being received at a microphone indicative of a user talking on the portable communication device; b) measuring at least one among a spectrum density and a spectrum energy of a bounced signal to determine the proximity of a user’s head to an earpiece of the portable communication device; c) measuring a predetermined period after a phone call starts; d) detecting an angle at which the portable communication device is positioned; e) detecting a vibration of the portable communication device; or f) detecting if the portable communication device is in a user’s hand. How the method 50 can detect the conditions described above can be embodied in many different forms

using individually or in combination sensors and timers and other devices”). A person of ordinary skill in the art at the time of the alleged invention would therefore have understood that the invention of Miyashita could be performed using a proximity sensor instead of or in addition to a gyro for the purpose of indicating whether a user is likely looking or not looking at the display of the mobile station and/or talking on the mobile station. As described above, and in elements [1b]-[1e], which are which are incorporated herein by reference, Miyashita already teaches at least a microprocessor adapted to (c) reduce power to the display if (i) the microprocessor determines that a telephone call is active and (ii) the gyro indicates the mobile station is in a vertical orientation. It would therefore be obvious and a person of ordinary skill in the art at the time of the invention would be motivated to use a microprocessor adapted to (c) reduce power to the display if (i) the microprocessor determines that a telephone call is active and (ii) the signal indicates the proximity of the external object (instead of or in addition to the gyro indicates the mobile station is in a vertical orientation). Doing so would be a design choice driven by a number of different reasons, including that it would support Miyashita’s ability to conserve battery power in mobile stations, and would be within the knowledge and ability of a person of ordinary skill in the art at the time of the alleged invention. Doing so would constitute, at least, combining prior art elements according to known methods to yield predictable results, a simple substitution of one known element for another to obtain predictable results, the use of a known technique to improve similar devices in the same way, the application of a known technique to a known device ready for improvement to yield a predictable result, and obvious to try.

To the extent Miyashita is deemed to not expressly or inherently disclose a microprocessor adapted to “reduce power to the display if (i) the microprocessor determines that a telephone call is active and (ii) the signal indicates the proximity of the external object,” it would be obvious to combine the disclosure of Miyashita with those of Numazawa as described in the Numazawa claim chart, which is incorporated herein in its entirety by reference. Miyashita and Numazawa are both directed to conserving battery power in mobile stations generally and more particularly at conserving battery power in mobile stations by using sensors to detect when the user of

the mobile station is in a call and unlikely to be looking at the display (as when, for example, the proximity sensor detects the user's ear by the mobile station or a sensor detects that the mobile station is in a vertical orientation) and to power off the display of mobile stations at such times. Miyashita at 1:58-63 (“The present invention is directed to solving the problem set forth above. It is therefore an object of the present invention to provide a portable telephone set which can shut off the power supply for a display portion while a content of the display will not be seen during speaking, and thus can reduce power consumption.”), 2:6-11 (“In the preferred construction the detector is a gyro. The control apparatus may shut off the power supply for the display when the detector detects the main body at a substantially vertical position. On the other hand, the control may initiate power supply for the display when the detector detects the main body at a substantially horizontal position.”); Numazawa at ¶ Abstract (“To achieve reduced power consumption through stopping operation of unnecessary functions during use of a wireless terminal. A CPU 2 identifies start of a call state through a signal from a signal processing portion 3 for controlling communication with a base station, and identifies, through an output signal from detecting means 6, whether or not a user ear is in contact with a terminal. Upon identification of contact of the ear to the terminal, controlling means 8 are caused to stop the supply of electric power, from a power supply 7, to displaying means 9 for providing information to a user, and lighting means 10, such as a black light.”), ¶ 0005-0007 (“In the present invention, control is such that, upon determination that the wireless terminal is in a call, operation of functions believe be unnecessary, due to the user of the terminal being in a call, is stopped, and upon termination of the call, operation of the stopped functions is restarted. Additionally, because it is envisioned that there will also be cases where, even during a call, the face of the user may be separated from the receiver of the terminal, control is performed so as to enable restarting of the operations of the functions that had been stopped as unnecessary, through detecting whether or not the user of the terminal has the receiver in contact with an ear. The achievement of reduced power consumption through stopping operation of functions that become unnecessary in use of the terminal, as described above, can be anticipated to have the effect of extending the life of the power supply, such as a battery.”). A person of ordinary skill in the art at the time of the alleged invention would be motivated to modify Miyashita to use a microprocessor adapted to “reduce power to the display if (i) the microprocessor determines that a telephone call is active and (ii) the signal indicates the proximity of

the external object,” as disclosed in Numazawa for a number of different reasons, including that it would support Miyashita’s ability to conserve battery power in mobile stations, and doing so would be within the knowledge and ability of a person of ordinary skill in the art at the time of the alleged invention. The combination would constitute, at least, combining prior art elements according to known methods to yield predictable results, a simple substitution of one known element for another to obtain predictable results, the use of a known technique to improve similar devices in the same way, the application of a known technique to a known device ready for improvement to yield a predictable result, and obvious to try.

To the extent Miyashita is deemed to not expressly or inherently disclose a microprocessor adapted to “reduce power to the display if (i) the microprocessor determines that a telephone call is active and (ii) the signal indicates the proximity of the external object,” it would be obvious to combine the disclosure of Miyashita with those of Perez as described in the Perez claim chart, which is incorporated herein in its entirety by reference. Miyashita and Perez are both directed to conserving battery power in mobile stations generally and more particularly at conserving battery power in mobile stations by using sensors to detect when the user of the mobile station is in a call and unlikely to be looking at the display (as when, for example, the proximity sensor detects the user’s ear by the mobile station or a sensor detects that the mobile station is in a vertical orientation) and to power off the display of mobile stations at such times. Miyashita at 1:58-63 (“The present invention is directed to solving the problem set forth above. It is therefore an object of the present invention to provide a portable telephone set which can shut off the power supply for a display portion while a content of the display will not be seen during speaking, and thus can reduce power consumption.”), 2:6-11 (“In the preferred construction the detector is a gyro. The control apparatus may shut off the power supply for the display when the detector detects the main body at a substantially vertical position. On the other hand, the control may initiate power supply for the display when the detector detects the main body at a substantially horizontal position.”); Perez at ¶ 0013 (“Referring to FIG. 1, a portable communication product 10 such as a cellular phone includes a transceiver radio having a microphone 20, an earpiece 22, a keypad 18 and a display 12 (such as a

color display) coupled to the transceiver radio. The portable communication product 10 further includes at least one sensor (24, 26, 28 or 30) and a processor 16. The sensor can be used for detecting a user condition of the portable communication device such as a talk condition when the user is assumed to be talking on the portable communication device. The processor 16 can be programmed to at least reduce power provided to the display 12 when the sensor detects the talk condition. The processor 16 can also turn off power to the display 12 during a talk condition if desired.”). A person of ordinary skill in the art at the time of the alleged invention would be motivated to modify Miyashita to use a microprocessor adapted to “reduce power to the display if (i) the microprocessor determines that a telephone call is active and (ii) the signal indicates the proximity of the external object,” as disclosed in Perez for a number of different reasons, including that it would support Miyashita’s ability to conserve battery power in mobile stations, and doing so would be within the knowledge and ability of a person of ordinary skill in the art at the time of the alleged invention. The combination would constitute, at least, combining prior art elements according to known methods to yield predictable results, a simple substitution of one known element for another to obtain predictable results, the use of a known technique to improve similar devices in the same way, the application of a known technique to a known device ready for improvement to yield a predictable result, and obvious to try.

To the extent Miyashita is deemed to not expressly or inherently disclose a microprocessor adapted to “reduce power to the display if (i) the microprocessor determines that a telephone call is active and (ii) the signal indicates the proximity of the external object,” it would be obvious to combine the disclosure of Miyashita with those of Seo as described in the Seo claim chart, which is incorporated herein in its entirety by reference. Miyashita and Seo are both directed to conserving battery power in mobile stations generally and more particularly at conserving battery power in mobile stations by using sensors to detect when the user of the mobile station is in a call and unlikely to be looking at the display (as when, for example, the proximity sensor detects the user’s ear by the mobile station or a sensor detects that the mobile station is in a vertical orientation) and to power off the display of mobile stations at such times. Miyashita at 1:58-63 (“The present invention is directed to solving the problem set

forth above. It is therefore an object of the present invention to provide a portable telephone set which can shut off the power supply for a display portion while a content of the display will not be seen during speaking, and thus can reduce power consumption.”), 2:6-11 (“In the preferred construction the detector is a gyro. The control apparatus may shut off the power supply for the display when the detector detects the main body at a substantially vertical position. On the other hand, the control may initiate power supply for the display when the detector detects the main body at a substantially horizontal position.”); Seo at 1:36-42 (“It is hence a primary object of the invention to present a novel cordless telephone capable of, by solving the above mentioned technical problems, stopping the display action by the display device while the handset is in service so as to minimize the wasteful consumption of the electric power supplied from the battery or the like.”), 3:64-4:5 (When the receiver 6 is not in contact with the user’s ear, the light emitting element 3 lights up at step n8. In this state, when the user touches the receiver 6 of the handset by the ear, it is detected by the piezoelectric element 7, and the detection signal is sent out to the control circuit 11. The control circuit 11, on the basis of this detection signal, sends out a stop signal to the driver 12. Thus, driving of the driver 12 is stopped, and the light emitting element 3 is extinguished at step n7.”). A person of ordinary skill in the art at the time of the alleged invention would be motivated to modify Miyashita to use a microprocessor adapted to “reduce power to the display if (i) the microprocessor determines that a telephone call is active and (ii) the signal indicates the proximity of the external object,” as disclosed in Seo for a number of different reasons, including that it would support Miyashita’s ability to conserve battery power in mobile stations, and doing so would be within the knowledge and ability of a person of ordinary skill in the art at the time of the alleged invention. The combination would constitute, at least, combining prior art elements according to known methods to yield predictable results, a simple substitution of one known element for another to obtain predictable results, the use of a known technique to improve similar devices in the same way, the application of a known technique to a known device ready for improvement to yield a predictable result, and obvious to try.

[1g] the telephone call is a wireless telephone call;

Miyashita discloses the telephone call as a wireless telephone call:

For example:

See discussion of claim element 1[d], *supra*, which is incorporated herein by reference.

“For a portable telephone set having a display portion for displaying various information associated with call or origination and reception, a gyro for detecting inclination of a main body is provided.” Miyashita at Abstract.

“The present invention relates to a pocket telephone or portable telephone set. More specifically, the invention relates to a portable telephone set which has a display for displaying various information associated with call origination and reception.” Miyashita at 1:6-10.

“The conventional portable telephone set has been designed to display a number as component of dialing operation on a display upon call origination. An example of such portable telephone set with a display function is illustrated in FIG. 4.

In such portable telephone, the number is input by operating dial buttons 8, and then a call origination button 9 is depressed. By these operations, a call is performed by a call control portion 3 and a radio communication portion 1. At this time, when a remote terminal answers, a speaking control portion 4 turns switches 11 and 13 to enable conversation with a destination via person a speaker 12 and a microphone 14.

On the other hand, when a call is received from the remote terminal, a reception control portion turns a switch 5. Then, a sound generator 6 becomes active to generate a ring sound. When a reception button 10 is depressed after the ring sound is

generated, the speaking control portion 4 turns switches 11 and 13 so as to enable speaking with the caller.” Miyashita at 1:12-31.

FIG. 2

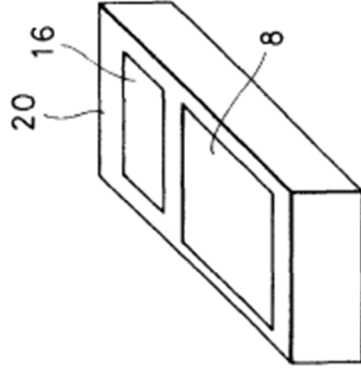
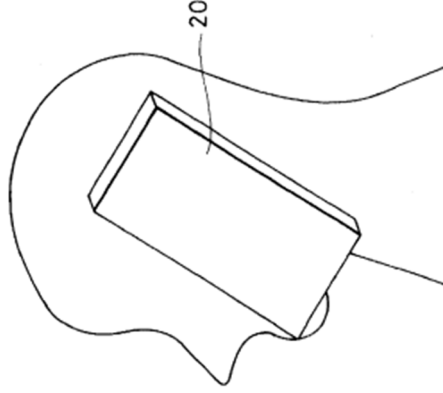

FIG. 3



Miyashita at Figs. 2, 3.

“FIG. 2 is an illustration showing inclination of the main body a during a dialing operation for the one embodiment of a portable telephone set according to the invention, and FIG. 3 is an illustration showing inclination of the main body during speaking and not out-dialing for the one embodiment of portable set according to the invention.” Miyashita at 4:3-8.

[1h] the microprocessor reduces power to the display while the signal indicates the proximity of the external object only if the microprocessor determines that the wireless telephone call is active; and

Miyashita discloses that the microprocessor reduces power to the display while the signal indicates the proximity of the external object only if the microprocessor determines that the wireless telephone call is active:

For example:

See discussion of claim element 1(f), *supra*, which is incorporated herein by reference.

“According to another aspect of the invention, a portable telephone set comprises:

call origination control device responsive to a dialing operation for controlling call origination;

reception control apparatus responsive to reception of call for controlling reception;

display device for displaying information associated with call origination and reception;

a main body housing the call origination control, the reception control and the display;

detector apparatus for detecting inclination of the main body; and

control for controlling the power supply for the display, the control being responsive to the detector detecting a, substantially horizontal position of the main body for initiating power supply for the display.

The control may be responsive to the detector detecting a substantially vertical position for speaking after dialing operation, for shutting off the power supply for the display.”
Miyashita at 2:12-32.

“The display control portion 17 is connected to a reception control portion 2, a call origination control portion 3 and a speaking control portion 4, respectively, via a

common path 19. Control information associated with speaking is displayed on the display portion 16. On the other hand, the display control portion 17 also controls power supply for the display portion 16.

The gyro 18 detects an inclination of a main body the portable telephone set to provide information concerning an inclination angle to the display control portion 17. The display control portion 17 receives the inclination angle information from the gyro 18. The display control portion 17 is responsive to the inclination angle information indicative of a substantially horizontal orientation of the main body and to one of reception control command from the reception control portion 2 and a call origination control command from the call origination control portion 3, to control a power source to supply a power to the display portion 16.

In contrast, the display control portion 17 is responsive to the inclination angle information indicative of variation of the inclination angle from the substantially horizontal orientation to the substantially vertical orientation while it performs display control for the display portion 16 to display the control information, to terminate the power supply for the display portion 16.

When speaking is performed with the destination person via the speaker 12 and the microphone 14, it is rare to require seeing the display content on the display portion 16. Therefore, the power supply for the display portion 16 is shut down. Thus, exhausting of a battery can be reduced.” Miyashita at 3:39-4:2.

“Thus, according to the shown embodiment, when the inclination angle information indicative that the main body is in a substantially horizontal orientation and when the reception control command from the reception control portion 2 and the call origination control command from the call origination control portion 3, the display control portion 17 starts the supply of the power. After speaking is started, when the inclination angle information indicative of a variation of orientation of the main body from the horizontal position to the vertical position, the display control portion shuts off power supply for the display portion 16. Therefore, in the state of the portable telephone set in which the display portion 16 will not be seen, no power will be

supplied to the display portion 16. Therefore, power consumption can be reduced. As well, it should serve for reducing the depletion of the battery.” Miyashita at 4:30-45.

To the extent Miyashita is deemed to not expressly disclose that “the microprocessor reduces power to the display while the signal indicates the proximity of the external object only if the microprocessor determines that the wireless telephone call is active,” Miyashita inherently discloses this limitation. As noted above for element [1f] and incorporated herein by reference, Miyashita discloses or renders obvious “a microprocessor adapted to reduce power to the display if (i) the microprocessor determines that a telephone call is active and (ii) the signal indicates the proximity of the external object.” Also as noted above for element [1d] and incorporated herein by reference, Miyashita discloses that detection by a sensor (such as a gyro or proximity sensor) occurs only “after talking is star[t]ed.” Therefore a person of ordinary skill in the art at the time of the alleged invention would understand that Miyashita necessarily discloses that “the microprocessor reduces power to the display while the signal indicates the proximity of the external object only if the microprocessor determines that the wireless telephone call is active.”

To the extent Miyashita is deemed to not expressly or inherently disclose that “the microprocessor reduces power to the display while the signal indicates the proximity of the external object only if the microprocessor determines that the wireless telephone call is active,” Miyashita renders it obvious to one of ordinary skill in the art at the time of the alleged invention. As noted above for element [1f] and incorporated herein by reference, Miyashita discloses or renders obvious “a microprocessor adapted to reduce power to the display if (i) the microprocessor determines that a telephone call is active and (ii) the signal indicates the proximity of the external object.” Also as noted above for element [1d] and incorporated herein by reference, Miyashita discloses that detection by a sensor (such as a gyro or proximity sensor) occurs only “after talking is started.” Therefore it would be obvious to one of ordinary skill in the art at the time of the alleged invention that “the microprocessor reduces power to the display while the

signal indicates the proximity of the external object only if the microprocessor determines that the wireless telephone call is active,” in Miyashita.

To the extent Miyashita is deemed to not expressly or inherently disclose a microprocessor adapted to “the microprocessor reduces power to the display while the signal indicates the proximity of the external object only if the microprocessor determines that the wireless telephone call is active” it would be obvious to combine the disclosure of Miyashita with those of Numazawa as described in the Numazawa claim chart, which is incorporated herein in its entirety by reference. Miyashita and Numazawa are both directed to conserving battery power in mobile stations generally and more particularly at conserving battery power in mobile stations by using sensors to detect when the user of the mobile station is in a call and unlikely to be looking at the display (as when, for example, the proximity sensor detects the user’s ear by the mobile station or a sensor detects that the mobile station is in a vertical orientation) and to power off the display of mobile stations at such times. Miyashita at 1:58-63 (“The present invention is directed to solving the problem set forth above. It is therefore an object of the present invention to provide a portable telephone set which can shut off the power supply for a display portion while a content of the display will not be seen during speaking, and thus can reduce power consumption.”), 2:6-11 (“In the preferred construction the detector is a gyro. The control apparatus may shut off the power supply for the display when the detector detects the main body at a substantially vertical position. On the other hand, the control may initiate power supply for the display when the detector detects the main body at a substantially horizontal position.”); Numazawa at ¶ Abstract (“To achieve reduced power consumption through stopping operation of unnecessary functions during use of a wireless terminal. A CPU 2 identifies start of a call state through a signal from a signal processing portion 3 for controlling communication with a base station, and identifies, through an output signal from detecting means 6, whether or not a user ear is in contact with a terminal. Upon identification of contact of the ear to the terminal, controlling means 8 are caused to stop the supply of electric power, from a power supply 7, to displaying means 9 for providing information to a user, and lighting means 10, such as a black light.”), ¶ 0005-0007 (“In the present invention, control is such that, upon determination that the

wireless terminal is in a call, operation of functions believe be unnecessary, due to the user of the terminal being in a call, is stopped, and upon termination of the call, operation of the stopped functions is restarted. Additionally, because it is envisioned that there will also be cases where, even during a call, the face of the user may be separated from the receiver of the terminal, control is performed so as to enable restarting of the operations of the functions that had been stopped as unnecessary, through detecting whether or not the user of the terminal has the receiver in contact with an ear. The achievement of reduced power consumption through stopping operation of functions that become unnecessary in use of the terminal, as described above, can be anticipated to have the effect of extending the life of the power supply, such as a battery.”). A person of ordinary skill in the art at the time of the alleged invention would be motivated to modify Miyashita to use a microprocessor adapted to “the microprocessor reduces power to the display while the signal indicates the proximity of the external object only if the microprocessor determines that the wireless telephone call is active” as disclosed in Numazawa for a number of different reasons, including that it would support Miyashita’s ability to conserve battery power in mobile stations, and doing so would be within the knowledge and ability of a person of ordinary skill in the art at the time of the alleged invention. The combination would constitute, at least, combining prior art elements according to known methods to yield predictable results, a simple substitution of one known element for another to obtain predictable results, the use of a known technique to improve similar devices in the same way, the application of a known technique to a known device ready for improvement to yield a predictable result, and obvious to try.

To the extent Miyashita is deemed to not expressly or inherently disclose a microprocessor adapted to “the microprocessor reduces power to the display while the signal indicates the proximity of the external object only if the microprocessor determines that the wireless telephone call is active” it would be obvious to combine the disclosure of Miyashita with those of Perez as described in the Perez claim chart, which is incorporated herein in its entirety by reference. Miyashita and Perez are both directed to conserving battery power in mobile stations generally and more particularly at conserving battery power in mobile stations by using sensors to detect when the user

of the mobile station is in a call and unlikely to be looking at the display (as when, for example, the proximity sensor detects the user's ear by the mobile station or a sensor detects that the mobile station is in a vertical orientation) and to power off the display of mobile stations at such times. Miyashita at 1:58-63 (“The present invention is directed to solving the problem set forth above. It is therefore an object of the present invention to provide a portable telephone set which can shut off the power supply for a display portion while a content of the display will not be seen during speaking, and thus can reduce power consumption.”), 2:6-11 (“In the preferred construction the detector is a gyro. The control apparatus may shut off the power supply for the display when the detector detects the main body at a substantially vertical position. On the other hand, the control may initiate power supply for the display when the detector detects the main body at a substantially horizontal position.”); Perez at ¶ 0013 (“Referring to FIG. 1, a portable communication product 10 such as a cellular phone includes a transceiver radio having a microphone 20, an earpiece 22, a keypad 18 and a display 12 (such as a color display) coupled to the transceiver radio. The portable communication product 10 further includes at least one sensor (24, 26, 28 or 30) and a processor 16. The sensor can be used for detecting a user condition of the portable communication device such as a talk condition when the user is assumed to be talking on the portable communication device. The processor 16 can be programmed to at least reduce power provided to the display 12 when the sensor detects the talk condition. The processor 16 can also turn off power to the display 12 during a talk condition if desired.”). A person of ordinary skill in the art at the time of the alleged invention would be motivated to modify Miyashita to use a microprocessor adapted to “the microprocessor reduces power to the display while the signal indicates the proximity of the external object only if the microprocessor determines that the wireless telephone call is active” as disclosed in Perez for a number of different reasons, including that it would support Miyashita’s ability to conserve battery power in mobile stations, and doing so would be within the knowledge and ability of a person of ordinary skill in the art at the time of the alleged invention. The combination would constitute, at least, combining prior art elements according to known methods to yield predictable results, a simple substitution of one known element for another to obtain predictable results, the use of a known technique to improve similar devices in the same way, the application of a known technique to a known device ready for improvement to yield a predictable result, and obvious to try.

To the extent Miyashita is deemed to not expressly or inherently disclose a microprocessor adapted to “reduce power to the display if (i) the microprocessor determines that a telephone call is active and (ii) the signal indicates the proximity of the external object,” it would be obvious to combine the disclosure of Miyashita with those of Seo as described in the Seo claim chart, which is incorporated herein in its entirety by reference. Miyashita and Seo are both directed to conserving battery power in mobile stations generally and more particularly at conserving battery power in mobile stations by using sensors to detect when the user of the mobile station is in a call and unlikely to be looking at the display (as when, for example, the proximity sensor detects the user’s ear by the mobile station or a sensor detects that the mobile station is in a vertical orientation) and to power off the display of mobile stations at such times. Miyashita at 1:58-63 (“The present invention is directed to solving the problem set forth above. It is therefore an object of the present invention to provide a portable telephone set which can shut off the power supply for a display portion while a content of the display will not be seen during speaking, and thus can reduce power consumption.”), 2:6-11 (“In the preferred construction the detector is a gyro. The control apparatus may shut off the power supply for the display when the detector detects the main body at a substantially vertical position. On the other hand, the control may initiate power supply for the display when the detector detects the main body at a substantially horizontal position.”); Seo at 1:36-42 (“It is hence a primary object of the invention to present a novel cordless telephone capable of, by solving the above mentioned technical problems, stopping the display action by the display device while the handset is in service so as to minimize the wasteful consumption of the electric power supplied from the battery or the like.”), 3:64-4:5 (When the receiver 6 is not in contact with the user’s ear, the light emitting element 3 lights up at step n8. In this state, when the user touches the receiver 6 of the handset by the ear, it is detected by the piezoelectric element 7, and the detection signal is sent out to the control circuit 11. The control circuit 11, on the basis of this detection signal, sends out a stop signal to the driver 12. Thus, driving of the driver 12 is stopped, and the light emitting element 3 is extinguished at step n7.”). A person of ordinary skill in the art at the time of the alleged invention would be motivated to modify Miyashita to use a microprocessor adapted to “the microprocessor reduces power to the display while the

	<p>signal indicates the proximity of the external object only if the microprocessor determines that the wireless telephone call is active” as disclosed in Seo for a number of different reasons, including that it would support Miyashita’s ability to conserve battery power in mobile stations, and doing so would be within the knowledge and ability of a person of ordinary skill in the art at the time of the alleged invention. The combination would constitute, at least, combining prior art elements according to known methods to yield predictable results, a simple substitution of one known element for another to obtain predictable results, the use of a known technique to improve similar devices in the same way, the application of a known technique to a known device ready for improvement to yield a predictable result, and obvious to try.</p>
<p>[11] the proximity sensor begins detecting whether an external object is proximate substantially concurrently with the mobile station initiating an outgoing wireless telephone call or receiving an incoming wireless telephone call.</p>	<p>Miyashita discloses that the proximity sensor begins to detect whether an external object is proximate substantially concurrently with the mobile station initiating an outgoing wireless telephone call or receiving an incoming wireless telephone call:</p> <p>For example:</p> <p><i>See</i> discussion of claim element 1(f), <i>supra</i>, which is incorporated herein by reference.</p> <p>“According to another aspect of the invention, a portable telephone set comprises:</p> <p>call origination control device responsive to a dialing operation for controlling call origination;</p> <p>reception control apparatus responsive to reception of call for controlling reception;</p> <p>display device for displaying information associated with call origination and reception;</p>

a main body housing the call origination control, the reception control and the display; detector apparatus for detecting inclination of the main body; and control for controlling the power supply for the display, the control being responsive to the detector detecting a, substantially horizontal position of the main body for initiating power supply for the display.

The control may be responsive to the detector detecting a substantially vertical position for speaking after dialing operation, for shutting off the power supply for the display.” Miyashita at 2:12-32.

“The display control portion 17 is connected to a reception control portion 2, a call origination control portion 3 and a speaking control portion 4, respectively, via a common path 19. Control information associated with speaking is displayed on the display portion 16. On the other hand, the display control portion 17 also controls power supply for the display portion 16.

The gyro 18 detects an inclination of a main body the portable telephone set to provide information concerning an inclination angle to the display control portion 17. The display control portion 17 receives the inclination angle information from the gyro 18. The display control portion 17 is responsive to the inclination angle information indicative of a substantially horizontal orientation of the main body and to one of reception control command from the reception control portion 2 and a call origination control command from the call origination control portion 3, to control a power source to supply a power to the display portion 16.

In contrast, the display control portion 17 is responsive to the inclination angle information indicative of variation of the inclination angle from the substantially horizontal orientation to the substantially vertical orientation while it performs display control for the display portion 16 to display the control information, to terminate the power supply for the display portion 16.

When speaking is performed with the destination person via the speaker 12 and the microphone 14, it is rare to require seeing the display content on the display portion 16. Therefore, the power supply for the display portion 16 is shut down. Thus, exhausting of a battery can be reduced.” Miyashita at 3:39-4:2.

“Thus, according to the shown embodiment, when the inclination angle information indicative that the main body is in a substantially horizontal orientation and when the reception control command from the reception control portion 2 and the call origination control command from the call origination control portion 3, the display control portion 17 starts the supply of the power. After speaking is started, when the inclination angle information indicative of a variation of orientation of the main body from the horizontal position to the vertical position, the display control portion shuts off power supply for the display portion 16. Therefore, in the state of the portable telephone set in which the display portion 16 will not be seen, no power will be supplied to the display portion 16. Therefore, power consumption can be reduced. As well, it should serve for reducing the depletion of the battery.” Miyashita at 4:30-45.

To the extent Miyashita is deemed to not expressly disclose “the proximity sensor begins detecting whether an external object is proximate substantially concurrently with the mobile station initiating an outgoing wireless telephone call or receiving an incoming wireless telephone call,” Miyashita inherently discloses this limitation. As noted above for claim element [1f] which is incorporated herein by reference, Miyashita discloses that the display control portion 17 is responsive to inclination angle information from the gyro only “after talking is start[ed].” A person of ordinary skill in the art at the time of the alleged invention would understand that “initiating an outgoing wireless telephone call or receiving an incoming wireless telephone call” is how a talking is started. Further, a person of ordinary skill in the art at the time of the alleged invention would understand that “the proximity sensor begins detecting whether an external object is proximate substantially concurrently with the mobile station initiating an outgoing wireless telephone call or receiving an incoming wireless telephone call” because Miyashita discloses that this is when the display control portion

17 would be receptive to a signal from a sensor (such as a gyro or proximity sensor). Thus, a person of ordinary skill in the art at the time of the alleged invention would understand Miyashita to inherently disclose that “the proximity sensor begins detecting whether an external object is proximate substantially concurrently with the mobile station initiating an outgoing wireless telephone call or receiving an incoming wireless telephone call.”

To the extent Miyashita is deemed to not expressly or inherently disclose “the proximity sensor begins detecting whether an external object is proximate substantially concurrently with the mobile station initiating an outgoing wireless telephone call or receiving an incoming wireless telephone call,” Miyashita renders it obvious to one of skill in the art to have “the proximity sensor begin[] detecting whether an external object is proximate substantially concurrently with the mobile station initiating an outgoing wireless telephone call or receiving an incoming wireless telephone call.” A person of ordinary skill in the art at the time of the alleged invention would understand that “initiating an outgoing wireless telephone call or receiving an incoming wireless telephone call” is how a talking is started. Further, it would be obvious to a person of ordinary skill in the art at the time of the alleged invention for “the proximity sensor [to] begin[] detecting whether an external object is proximate substantially concurrently with the mobile station initiating an outgoing wireless telephone call or receiving an incoming wireless telephone call” because that is the only time when Miyashita discloses that the display control portion 17 would be receptive to a signal from a sensor (such as a gyro or proximity sensor). Because this is the only time that the signal is monitored, it would be obvious to a person of ordinary skill in the art at the time of the alleged invention that the proximity sensor should begin detecting substantially concurrently with the start of this period in order to save additional power.

To the extent Miyashita is deemed to not expressly or inherently disclose “the proximity sensor begins detecting whether an external object is proximate substantially concurrently with the mobile station initiating an outgoing wireless telephone call or receiving an incoming wireless telephone call,” it would be obvious to combine the

disclosure of Miyashita with those of Numazawa as described in the Numazawa claim chart, which is incorporated herein in its entirety by reference. Miyashita and Numazawa are both directed to conserving battery power in mobile stations generally and more particularly at conserving battery power in mobile stations by using sensors to detect when the user of the mobile station is in a call and unlikely to be looking at the display (as when, for example, the proximity sensor detects the user's ear by the mobile station or a sensor detects that the mobile station is in a vertical orientation) and to power off the display of mobile stations at such times. Miyashita at 3:58-4:2 (“In contrast, the display control portion 17 is responsive to the inclination angle information indicative of variation of the inclination angle from the substantially horizontal orientation to the substantially vertical orientation while it performs display control for the display portion 16 to display the control information, to terminate the power supply for the display portion 16. When speaking is performed with the destination person via the speaker 12 and the microphone 14, it is rare to require seeing the display content on the display portion 16. Therefore, the power supply for the display portion 16 is shut down. Thus, exhausting of a battery can be reduced.”); Numazawa at ¶ Abstract (“To achieve reduced power consumption through stopping operation of unnecessary functions during use of a wireless terminal. A CPU 2 identifies start of a call state through a signal from a signal processing portion 3 for controlling communication with a base station, and identifies, through an output signal from detecting means 6, whether or not a user ear is in contact with a terminal. Upon identification of contact of the ear to the terminal, controlling means 8 are caused to stop the supply of electric power, from a power supply 7, to displaying means 9 for providing information to a user, and lighting means 10, such as a black light.”), ¶ 0005-0007 (“In the present invention, control is such that, upon determination that the wireless terminal is in a call, operation of functions believe be unnecessary, due to the user of the terminal being in a call, is stopped, and upon termination of the call, operation of the stopped functions is restarted. Additionally, because it is envisioned that there will also be cases where, even during a call, the face of the user may be separated from the receiver of the terminal, control is performed so as to enable restarting of the operations of the functions that had been stopped as unnecessary, through detecting whether or not the user of the terminal has the receiver in contact with an ear. The achievement of reduced power consumption through stopping operation of functions that become unnecessary in use of the terminal, as described

above, can be anticipated to have the effect of extending the life of the power supply, such as a battery.”). While Miyashita discloses a gyro, it would be obvious to one of ordinary skill in the art at the time of the alleged invention to modify Miyashita’s gyro to function in the same way as the proximity sensor in Numazawa as both sensors serve the same function (to serve as an indication that the mobile station’s display is unlikely to be viewed and can therefore be powered off). A person of ordinary skill in the art at the time of the alleged invention would therefore be motivated to modify Miyashita to have “the proximity sensor begin[] detecting whether an external object is proximate substantially concurrently with the mobile station initiating an outgoing wireless telephone call or receiving an incoming wireless telephone call” as disclosed in Numazawa because the proximity sensor does not need to be detecting when its output is not being monitored, and beginning detecting only during the period when the signal is being monitored would save additional power. The combination would constitute, at least, combining prior art elements according to known methods to yield predictable results, a simple substitution of one known element for another to obtain predictable results, the use of a known technique to improve similar devices in the same way, the application of a known technique to a known device ready for improvement to yield a predictable result, and obvious to try.

To the extent Miyashita is deemed to not expressly or inherently disclose “the proximity sensor begins detecting whether an external object is proximate substantially concurrently with the mobile station initiating an outgoing wireless telephone call or receiving an incoming wireless telephone call,” it would be obvious to combine the disclosure of Miyashita with those of Seo as described in the Seo claim chart, which is incorporated herein in its entirety by reference. Miyashita and Seo are both directed to conserving battery power in mobile stations generally and more particularly at conserving battery power in mobile stations by using sensors to detect when the user of the mobile station is in a call and unlikely to be looking at the display (as when, for example, the proximity sensor detects the user’s car by the mobile station or a sensor detects that the mobile station is in a vertical orientation) and to power off the display of mobile stations at such times. Miyashita at 3:58-4:2 (“In contrast, the display control portion 17 is responsive to the inclination angle information indicative of variation of

the inclination angle from the substantially horizontal orientation to the substantially vertical orientation while it performs display control for the display portion 16 to display the control information, to terminate the power supply for the display portion 16. When speaking is performed with the destination person via the speaker 12 and the microphone 14, it is rare to require seeing the display content on the display portion 16. Therefore, the power supply for the display portion 16 is shut down. Thus, exhausting of a battery can be reduced.’). Seo at 1:36-42 (“It is hence a primary object of the invention to present a novel cordless telephone capable of, by solving the above mentioned technical problems, stopping the display action by the display device while the handset is in service so as to minimize the wasteful consumption of the electric power supplied from the battery or the like.”), 3:64-4:5 (When the receiver 6 is not in contact with the user’s ear, the light emitting element 3 lights up at step n8. In this state, when the user touches the receiver 6 of the handset by the ear, it is detected by the piezoelectric element 7, and the detection signal is sent out to the control circuit 11. The control circuit 11, on the basis of this detection signal, sends out a stop signal to the driver 12. Thus, driving of the driver 12 is stopped, and the light emitting element 3 is extinguished at step n7.”); While Miyashita discloses a gyro, it would be obvious to one of ordinary skill in the art at the time of the alleged invention to modify Miyashita’s gyro to function in the same way as the proximity sensor in Seo as both sensors serve the same function (to serve as an indication that the mobile station’s display is unlikely to be viewed and can therefore be powered off). A person of ordinary skill in the art at the time of the alleged invention would therefore be motivated to modify Miyashita to have “the proximity sensor begin[] detecting whether an external object is proximate substantially concurrently with the mobile station initiating an outgoing wireless telephone call or receiving an incoming wireless telephone call” as disclosed in Seo because the proximity sensor does not need to be detecting when its output is not being monitored, and beginning detecting only during the period when the signal is being monitored would save additional power. The combination would constitute, at least, combining prior art elements according to known methods to yield predictable results, a simple substitution of one known element for another to obtain predictable results, the use of a known technique to improve similar devices in the same way, the application of a known technique to a known device ready for improvement to yield a predictable result, and obvious to try.

<p>[Claim 2] The mobile station of claim 1, wherein the microprocessor reduces power to the display only if (i) the microprocessor determines that a telephone call is active and (ii) the signal indicates the proximity of the external object.</p>	<p>Miyashita discloses the microprocessor reducing power to the display only if (i) the microprocessor determines that a telephone call is active and (ii) the signal indicates the proximity of the external object:</p> <p>For example:</p> <p><i>See</i> discussion of claim element 1(f), <i>supra</i>, which is incorporated herein by reference.</p>
<p>[Claim 4] The mobile station as recited in claim 1, wherein the microprocessor reduces power to the display by turning off the display.</p>	<p>Miyashita discloses the microprocessor reducing power to the display by turning off the display:</p> <p>For example:</p> <p>“In contrast, the display control portion 17 is responsive to the inclination angle information indicative of variation of the inclination angle from the substantially horizontal orientation to the substantially vertical orientation while it performs display control for the display portion 16 to display the control information, to terminate the power supply for the display portion 16.</p> <p>When speaking is performed with the destination person via the speaker 12 and the microphone 14, it is rare to require seeing the display content on the display portion 16. Therefore, the power supply for the display portion 16 is shut down. Thus, exhausting of a battery can be reduced.” Miyashita at 3:58-4:2.</p>

“Thus, according to the shown embodiment, when the inclination angle information indicative that the main body is in a substantially horizontal orientation and when the reception control command from the reception control portion 2 and the call origination control command from the call origination control portion 3, the display control portion 17 starts the supply of the power. After speaking is started, when the inclination angle information indicative of a variation of orientation of the main body from the horizontal position to the vertical position, the display control portion shuts off power supply for the display portion 16. Therefore, in the state of the portable telephone set in which the display portion 16 will not be seen, no power will be supplied to the display portion 16. Therefore, power consumption can be reduced. As well, it should serve for reducing the depletion of the battery.” Miyashita at 4:30-45.

See discussion of claim element 1(f), *supra*, which is incorporated herein by reference.

To the extent Miyashita is deemed to not expressly or inherently disclose “the microprocessor reduces power to the display by turning off the display,” Miyashita renders it obvious to one of ordinary skill in the art at the time of the alleged invention. Miyashita discloses a gyro that indicates the inclination angle (vertical vs. horizontal) of the mobile station for the purpose of indicating whether a user is likely looking or not looking at the display of the mobile station and/or talking on the mobile station. *See* Miyashita at 3:46-4:2 (“The gyro 18 detects an inclination of a main body the portable telephone set to provide information concerning an inclination angle to the display control portion 17. The display control portion 17 receives the inclination angle information from the gyro 18. The display control portion 17 is responsive to the inclination angle information indicative of a substantially horizontal orientation of the main body and to one of reception control command from the reception control portion 2 and a call origination control command from the call origination control portion 3, to control a power source to supply a power to the display portion 16. In contrast, the display control portion 17 is responsive to the inclination angle information indicative of variation of the inclination angle from the substantially horizontal orientation to the substantially vertical orientation while it performs display control for the display portion 16 to display the control information, to terminate the

power supply for the display portion 16. When speaking is performed with the destination person via the speaker 12 and the microphone 14, it is rare to require seeing the display content on the display portion 16. Therefore, the power supply for the display portion 16 is shut down. Thus, exhausting of a battery can be reduced.”). A person of ordinary skill in the art at the time of the alleged invention would have understood that various sensors can be used in a mobile station for the purpose of indicating whether a user is likely looking or not looking at the display of the mobile station and/or talking on the mobile station. *See, e.g.,* Perez at ¶ 0022 (“[T]he step of detecting a talk condition can be achieved by monitoring or detecting at least one among the conditions of a) detecting if a predetermined volume of acoustic sound is being received at a microphone indicative of a user talking on the portable communication device; b) measuring at least one among a spectrum density and a spectrum energy of a bounced signal to determine the proximity of a user’s head to an earpiece of the portable communication device; c) measuring a predetermined period after a phone call starts; d) detecting an angle at which the portable communication device is positioned; e) detecting a vibration of the portable communication device; or f) detecting if the portable communication device is in a user’s hand. How the method 50 can detect the conditions described above can be embodied in many different forms using individually or in combination sensors and timers and other devices”). A person of ordinary skill in the art at the time of the alleged invention would therefore have understood that the invention of Miyashita could be performed using a proximity sensor instead of or in addition to a gyro for the purpose of indicating whether a user is likely looking or not looking at the display of the mobile station and/or talking on the mobile station. As described above, and in elements [1b]-[1e], which are incorporated herein by reference, Miyashita already teaches at least a microprocessor adapted to (c) reduce power to the display if (i) the microprocessor determines that a telephone call is active and (ii) the gyro indicates the mobile station is in a vertical orientation. It would therefore be obvious and a person of ordinary skill in the art at the time of the invention would be motivated to reduce power to the display by turning off the display. Doing so would be a design choice driven by a number of different reasons, including that it would support Miyashita’s ability to conserve battery power in mobile stations, and would be within the knowledge and ability of a person of ordinary skill in the art at the time of the alleged invention. Doing so would constitute, at least, combining prior art elements according to known methods to yield predictable results, a simple

substitution of one known element for another to obtain predictable results, the use of a known technique to improve similar devices in the same way, the application of a known technique to a known device ready for improvement to yield a predictable result, and obvious to try.

To the extent Miyashita is deemed to not expressly or inherently disclose “the microprocessor reduces power to the display by turning off the display,” it would be obvious to combine the disclosure of Miyashita with those of Numazawa as described in the Numazawa claim chart, which is incorporated herein in its entirety by reference. Miyashita and Numazawa are both directed to conserving battery power in mobile stations generally and more particularly at conserving battery power in mobile stations by using sensors to detect when the user of the mobile station is in a call and unlikely to be looking at the display (as when, for example, the proximity sensor detects the user’s ear by the mobile station or a sensor detects that the mobile station is in a vertical orientation) and to power off the display of mobile stations at such times. Miyashita at 1:58-63 (“The present invention is directed to solving the problem set forth above. It is therefore an object of the present invention to provide a portable telephone set which can shut off the power supply for a display portion while a content of the display will not be seen during speaking, and thus can reduce power consumption.”), 2:6-11 (“In the preferred construction the detector is a gyro. The control apparatus may shut off the power supply for the display when the detector detects the main body at a substantially vertical position. On the other hand, the control may initiate power supply for the display when the detector detects the main body at a substantially horizontal position.”); Numazawa at ¶ Abstract (“To achieve reduced power consumption through stopping operation of unnecessary functions during use of a wireless terminal. A CPU 2 identifies start of a call state through a signal from a signal processing portion 3 for controlling communication with a base station, and identifies, through an output signal from detecting means 6, whether or not a user ear is in contact with a terminal. Upon identification of contact of the ear to the terminal, controlling means 8 are caused to stop the supply of electric power, from a power supply 7, to displaying means 9 for providing information to a user, and lighting means 10, such as a black light.”), ¶ 0005-0007 (“In the present invention, control is such that, upon determination that the

wireless terminal is in a call, operation of functions believe be unnecessary, due to the user of the terminal being in a call, is stopped, and upon termination of the call, operation of the stopped functions is restarted. Additionally, because it is envisioned that there will also be cases where, even during a call, the face of the user may be separated from the receiver of the terminal, control is performed so as to enable restarting of the operations of the functions that had been stopped as unnecessary, through detecting whether or not the user of the terminal has the receiver in contact with an ear. The achievement of reduced power consumption through stopping operation of functions that become unnecessary in use of the terminal, as described above, can be anticipated to have the effect of extending the life of the power supply, such as a battery.”). A person of ordinary skill in the art at the time of the alleged invention would be motivated to modify Miyashita such that its microprocessor reduces power to the display by turning off the display, as disclosed in Numazawa for a number of different reasons, including that it would support Miyashita’s ability to conserve battery power in mobile stations, and doing so would be within the knowledge and ability of a person of ordinary skill in the art at the time of the alleged invention. The combination would constitute, at least, combining prior art elements according to known methods to yield predictable results, a simple substitution of one known element for another to obtain predictable results, the use of a known technique to improve similar devices in the same way, the application of a known technique to a known device ready for improvement to yield a predictable result, and obvious to try.

To the extent Miyashita is deemed to not expressly or inherently “the microprocessor reduces power to the display by turning off the display,” it would be obvious to combine the disclosure of Miyashita with those of Perez as described in the Perez claim chart, which is incorporated herein in its entirety by reference. Miyashita and Perez are both directed to conserving battery power in mobile stations generally and more particularly at conserving battery power in mobile stations by using sensors to detect when the user of the mobile station is in a call and unlikely to be looking at the display (as when, for example, the proximity sensor detects the user’s ear by the mobile station or a sensor detects that the mobile station is in a vertical orientation) and to power off the display of mobile stations at such times. Miyashita at 1:58-63 (“The present

invention is directed to solving the problem set forth above. It is therefore an object of the present invention to provide a portable telephone set which can shut off the power supply for a display portion while a content of the display will not be seen during speaking, and thus can reduce power consumption.”); 2:6-11 (“In the preferred construction the detector is a gyro. The control apparatus may shut off the power supply for the display when the detector detects the main body at a substantially vertical position. On the other hand, the control may initiate power supply for the display when the detector detects the main body at a substantially horizontal position.”); Perez at ¶ 0013 (“Referring to FIG. 1, a portable communication product 10 such as a cellular phone includes a transmitter radio having a microphone 20, an earpiece 22, a keypad 18 and a display 12 (such as a color display) coupled to the transmitter radio. The portable communication product 10 further includes at least one sensor (24, 26, 28 or 30) and a processor 16. The sensor can be used for detecting a user condition of the portable communication device such as a talk condition when the user is assumed to be talking on the portable communication device. The processor 16 can be programmed to at least reduce power provided to the display 12 when the sensor detects the talk condition. The processor 16 can also turn off power to the display 12 during a talk condition if desired.”). A person of ordinary skill in the art at the time of the alleged invention would be motivated to modify Miyashita to “reduce[] power to the display by turning off the display,” as disclosed in Perez for a number of different reasons, including that it would support Miyashita’s ability to conserve battery power in mobile stations, and doing so would be within the knowledge and ability of a person of ordinary skill in the art at the time of the alleged invention. The combination would constitute, at least, combining prior art elements according to known methods to yield predictable results, a simple substitution of one known element for another to obtain predictable results, the use of a known technique to improve similar devices in the same way, the application of a known technique to a known device ready for improvement to yield a predictable result, and obvious to try.

To the extent Miyashita is deemed to not expressly or inherently disclose “the microprocessor reduces power to the display by turning off the display,” it would be obvious to combine the disclosure of Miyashita with those of Seo as described in the

Seo claim chart, which is incorporated herein in its entirety by reference. Miyashita and Seo are both directed to conserving battery power in mobile stations generally and more particularly at conserving battery power in mobile stations by using sensors to detect when the user of the mobile station is in a call and unlikely to be looking at the display (as when, for example, the proximity sensor detects the user's ear by the mobile station or a sensor detects that the mobile station is in a vertical orientation) and to power off the display of mobile stations at such times. Miyashita at 1:58-63 (“The present invention is directed to solving the problem set forth above. It is therefore an object of the present invention to provide a portable telephone set which can shut off the power supply for a display portion while a content of the display will not be seen during speaking, and thus can reduce power consumption.”), 2:6-11 (“In the preferred construction the detector is a gyro. The control apparatus may shut off the power supply for the display when the detector detects the main body at a substantially vertical position. On the other hand, the control may initiate power supply for the display when the detector detects the main body at a substantially horizontal position.”); Seo at 1:36-42 (“It is hence a primary object of the invention to present a novel cordless telephone capable of, by solving the above mentioned technical problems, stopping the display action by the display device while the handset is in service so as to minimize the wasteful consumption of the electric power supplied from the battery or the like.”), 3:64-4:5 (When the receiver 6 is not in contact with the user's ear, the light emitting element 3 lights up at step n8. In this state, when the user touches the receiver 6 of the handset by the ear, it is detected by the piezoelectric element 7, and the detection signal is sent out to the control circuit 11. The control circuit 11, on the basis of this detection signal, sends out a stop signal to the driver 12. Thus, driving of the driver 12 is stopped, and the light emitting element 3 is extinguished at step n7.”). A person of ordinary skill in the art at the time of the alleged invention would be motivated to modify Miyashita's processor to reduce power to the display by turning off the display, as disclosed in Seo, for a number of different reasons, including that it would support Miyashita's ability to conserve battery power in mobile stations, and doing so would be within the knowledge and ability of a person of ordinary skill in the art at the time of the alleged invention. The combination would constitute, at least, combining prior art elements according to known methods to yield predictable results, a simple substitution of one known element for another to obtain predictable results, the use of a known technique to improve similar devices in the

	<p>same way, the application of a known technique to a known device ready for improvement to yield a predictable result, and obvious to try.</p>
<p>[Claim 5] The mobile station as recited in claim 1, wherein the proximity sensor is a mechanical proximity sensor, an optical sensor, or a range-detecting sensor.</p>	<p>Miyashita discloses that the proximity sensor is a mechanical proximity sensor, an optical sensor, or a range-detecting sensor:</p> <p>For example:</p> <p><i>See</i> discussion of claim elements 1(b) and 1(e), <i>supra</i>, which is incorporated herein by reference.</p> <p>To the extent Miyashita is deemed to not expressly or inherently disclose “[t]he mobile station as recited in claim 1, wherein the proximity sensor is a mechanical proximity sensor, an optical sensor, or a range-detecting sensor” it would be obvious to combine the disclosure of Miyashita with those of Numazawa as described in the Numazawa claim chart, which is incorporated herein in its entirety by reference. Miyashita and Numazawa are both directed to conserving battery power in mobile stations generally and more particularly at conserving battery power in mobile stations by using sensors to detect when the user of the mobile station is in a call and unlikely to be looking at the display (as when, for example, the proximity sensor detects the user’s ear by the mobile station or a sensor detects that the mobile station is in a vertical orientation) and to power off the display of mobile stations at such times. Miyashita at 1:58-63 (“The present invention is directed to solving the problem set forth above. It is therefore an object of the present invention to provide a portable telephone set which can shut off the power supply for a display portion while a content of the display will not be seen during speaking, and thus can reduce power consumption.”), 2:6-11 (“In the preferred construction the detector is a gyro. The control apparatus may shut off the power</p>

supply for the display when the detector detects the main body at a substantially vertical position. On the other hand, the control may initiate power supply for the display when the detector detects the main body at a substantially horizontal position.”); Numazawa at ¶ Abstract (“To achieve reduced power consumption through stopping operation of unnecessary functions during use of a wireless terminal. A CPU 2 identifies start of a call state through a signal from a signal processing portion 3 for controlling communication with a base station, and identifies, through an output signal from detecting means 6, whether or not a user ear is in contact with a terminal. Upon identification of contact of the ear to the terminal, controlling means 8 are caused to stop the supply of electric power, from a power supply 7, to displaying means 9 for providing information to a user, and lighting means 10, such as a black light.”), ¶ 0005-0007 (“In the present invention, control is such that, upon determination that the wireless terminal is in a call, operation of functions believe be unnecessary, due to the user of the terminal being in a call, is stopped, and upon termination of the call, operation of the stopped functions is restarted. Additionally, because it is envisioned that there will also be cases where, even during a call, the face of the user may be separated from the receiver of the terminal, control is performed so as to enable restarting of the operations of the functions that had been stopped as unnecessary, through detecting whether or not the user of the terminal has the receiver in contact with an ear. The achievement of reduced power consumption through stopping operation of functions that become unnecessary in use of the terminal, as described above, can be anticipated to have the effect of extending the life of the power supply, such as a battery.”). A person of ordinary skill in the art at the time of the alleged invention would be motivated to modify Miyashita to use “[t]he mobile station as recited in claim 1, wherein the proximity sensor is a mechanical proximity sensor, an optical sensor, or a range-detecting sensor” as disclosed in Numazawa for a number of different reasons, including that it would support Miyashita’s ability to conserve battery power in mobile stations, and doing so would be within the knowledge and ability of a person of ordinary skill in the art at the time of the alleged invention. The combination would constitute, at least, combining prior art elements according to known methods to yield predictable results, a simple substitution of one known element for another to obtain predictable results, the use of a known technique to improve similar devices in

the same way, the application of a known technique to a known device ready for improvement to yield a predictable result, and obvious to try.

To the extent Miyashita is deemed to not expressly or inherently disclose “[t]he mobile station as recited in claim 1, wherein the proximity sensor is a mechanical proximity sensor, an optical sensor, or a range-detecting sensor,” it would be obvious to combine the disclosure of Miyashita with those of Perez as described in the Perez claim chart, which is incorporated herein in its entirety by reference. Miyashita and Perez are both directed to conserving battery power in mobile stations generally and more particularly at conserving battery power in mobile stations by using sensors to detect when the user of the mobile station is in a call and unlikely to be looking at the display (as when, for example, the proximity sensor detects the user’s ear by the mobile station or a sensor detects that the mobile station is in a vertical orientation) and to power off the display of mobile stations at such times. Miyashita at 1:58-63 (“The present invention is directed to solving the problem set forth above. It is therefore an object of the present invention to provide a portable telephone set which can shut off the power supply for a display portion while a content of the display will not be seen during speaking, and thus can reduce power consumption.”), 2:6-11 (“In the preferred construction the detector is a gyro. The control apparatus may shut off the power supply for the display when the detector detects the main body at a substantially vertical position. On the other hand, the control may initiate power supply for the display when the detector detects the main body at a substantially horizontal position.”); Perez at ¶ 0013 (“Referring to FIG. 1, a portable communication product 10 such as a cellular phone includes a transceiver radio having a microphone 20, an earpiece 22, a keypad 18 and a display 12 (such as a color display) coupled to the transceiver radio. The portable communication product 10 further includes at least one sensor (24, 26, 28 or 30) and a processor 16. The sensor can be used for detecting a user condition of the portable communication device such as a talk condition when the user is assumed to be talking on the portable communication device. The processor 16 can be programmed to at least reduce power provided to the display 12 when the sensor detects the talk condition. The processor 16 can also turn off power to the display 12 during a talk condition if desired.”). A person of ordinary skill in the art at the time of the alleged invention would be motivated to

modify Miyashita to use “[t]he mobile station as recited in claim 1, wherein the proximity sensor is a mechanical proximity sensor, an optical sensor, or a range-detecting sensor,” as disclosed in Perez for a number of different reasons, including that it would support Miyashita’s ability to conserve battery power in mobile stations, and doing so would be within the knowledge and ability of a person of ordinary skill in the art at the time of the alleged invention. The combination would constitute, at least, combining prior art elements according to known methods to yield predictable results, a simple substitution of one known element for another to obtain predictable results, the use of a known technique to improve similar devices in the same way, the application of a known technique to a known device ready for improvement to yield a predictable result, and obvious to try.

To the extent Miyashita is deemed to not expressly or inherently disclose “[t]he mobile station as recited in claim 1, wherein the proximity sensor is a mechanical proximity sensor, an optical sensor, or a range-detecting sensor,” it would be obvious to combine the disclosure of Miyashita with those of Seo as described in the Seo claim chart, which is incorporated herein in its entirety by reference. Miyashita and Seo are both directed to conserving battery power in mobile stations generally and more particularly at conserving battery power in mobile stations by using sensors to detect when the user of the mobile station is in a call and unlikely to be looking at the display (as when, for example, the proximity sensor detects the user’s ear by the mobile station or a sensor detects that the mobile station is in a vertical orientation) and to power off the display of mobile stations at such times. Miyashita at 1:58-63 (“The present invention is directed to solving the problem set forth above. It is therefore an object of the present invention to provide a portable telephone set which can shut off the power supply for a display portion while a content of the display will not be seen during speaking, and thus can reduce power consumption.”), 2:6-11 (“In the preferred construction the detector is a gyro. The control apparatus may shut off the power supply for the display when the detector detects the main body at a substantially vertical position. On the other hand, the control may initiate power supply for the display when the detector detects the main body at a substantially horizontal position.”); Seo at 1:36-42 (“It is hence a primary object of the invention to present a novel cordless telephone capable of, by

	<p>solving the above mentioned technical problems, stopping the display action by the display device while the handset is in service so as to minimize the wasteful consumption of the electric power supplied from the battery or the like.”), 3:64-4:5 (When the receiver 6 is not in contact with the user's ear, the light emitting element 3 lights up at step n8. In this state, when the user touches the receiver 6 of the handset by the ear, it is detected by the piezoelectric element 7, and the detection signal is sent out to the control circuit 11. The control circuit 11, on the basis of this detection signal, sends out a stop signal to the driver 12. Thus, driving of the driver 12 is stopped, and the light emitting element 3 is extinguished at step n7.”). A person of ordinary skill in the art at the time of the alleged invention would be motivated to modify Miyashita to use “[t]he mobile station as recited in claim 1, wherein the proximity sensor is a mechanical proximity sensor, an optical sensor, or a range-detecting sensor,” as disclosed in Seo for a number of different reasons, including that it would support Miyashita’s ability to conserve battery power in mobile stations, and doing so would be within the knowledge and ability of a person of ordinary skill in the art at the time of the alleged invention. The combination would constitute, at least, combining prior art elements according to known methods to yield predictable results, a simple substitution of one known element for another to obtain predictable results, the use of a known technique to improve similar devices in the same way, the application of a known technique to a known device ready for improvement to yield a predictable result, and obvious to try.</p>
<p>[Claim 6] The mobile station as recited in claim 1, wherein the proximity sensor is located proximate to the display.</p>	<p>Miyashita discloses that the proximity sensor is located proximate to the display:</p> <p>For example:</p> <p><i>See</i> discussion of claim elements 1 (b) and 1 (e), <i>supra</i>, which is incorporated herein by reference.</p>

To the extent Miyashita is deemed to not expressly or inherently disclose “[t]he mobile station as recited in claim 1, wherein the proximity sensor is located proximate to the display,” it would be obvious to combine the disclosure of Miyashita with those of Numazawa as described in the Numazawa claim chart, which is incorporated herein in its entirety by reference. Miyashita and Numazawa are both directed to conserving battery power in mobile stations generally and more particularly at conserving battery power in mobile stations by using sensors to detect when the user of the mobile station is in a call and unlikely to be looking at the display (as when, for example, the proximity sensor detects the user’s ear by the mobile station or a sensor detects that the mobile station is in a vertical orientation) and to power off the display of mobile stations at such times. Miyashita at 1:58-63 (“The present invention is directed to solving the problem set forth above. It is therefore an object of the present invention to provide a portable telephone set which can shut off the power supply for a display portion while a content of the display will not be seen during speaking, and thus can reduce power consumption.”), 2:6-11 (“In the preferred construction the detector is a gyro. The control apparatus may shut off the power supply for the display when the detector detects the main body at a substantially vertical position. On the other hand, the control may initiate power supply for the display when the detector detects the main body at a substantially horizontal position.”); Numazawa at ¶ Abstract (“To achieve reduced power consumption through stopping operation of unnecessary functions during use of a wireless terminal. A CPU 2 identifies start of a call state through a signal from a signal processing portion 3 for controlling communication with a base station, and identifies, through an output signal from detecting means 6, whether or not a user ear is in contact with a terminal. Upon identification of contact of the ear to the terminal, controlling means 8 are caused to stop the supply of electric power, from a power supply 7, to displaying means 9 for providing information to a user, and lighting means 10, such as a black light.”), ¶ 0005-0007 (“In the present invention, control is such that, upon determination that the wireless terminal is in a call, operation of functions believe be unnecessary, due to the user of the terminal being in a call, is stopped, and upon termination of the call, operation of the stopped functions is restarted. Additionally, because it is envisioned that there will also be cases where, even during a call, the face of the user may be separated from the receiver of the terminal,

control is performed so as to enable restarting of the operations of the functions that had been stopped as unnecessary, through detecting whether or not the user of the terminal has the receiver in contact with an ear. The achievement of reduced power consumption through stopping operation of functions that become unnecessary in use of the terminal, as described above, can be anticipated to have the effect of extending the life of the power supply, such as a battery.”). A person of ordinary skill in the art at the time of the alleged invention would be motivated to modify Miyashita to use [t]he mobile station as recited in claim 1, wherein the proximity sensor is located proximate to the display” as disclosed in Numazawa for a number of different reasons, including that it would support Miyashita’s ability to conserve battery power in mobile stations, and doing so would be within the knowledge and ability of a person of ordinary skill in the art at the time of the alleged invention. The combination would constitute, at least, combining prior art elements according to known methods to yield predictable results, a simple substitution of one known element for another to obtain predictable results, the use of a known technique to improve similar devices in the same way, the application of a known technique to a known device ready for improvement to yield a predictable result, and obvious to try.

To the extent Miyashita is deemed to not expressly or inherently disclose [t]he mobile station as recited in claim 1, wherein the proximity sensor is located proximate to the display,” it would be obvious to combine the disclosure of Miyashita with those of Perez as described in the Perez claim chart, which is incorporated herein in its entirety by reference. Miyashita and Perez are both directed to conserving battery power in mobile stations generally and more particularly at conserving battery power in mobile stations by using sensors to detect when the user of the mobile station is in a call and unlikely to be looking at the display (as when, for example, the proximity sensor detects the user’s ear by the mobile station or a sensor detects that the mobile station is in a vertical orientation) and to power off the display of mobile stations at such times. Miyashita at 1:58-63 (“The present invention is directed to solving the problem set forth above. It is therefore an object of the present invention to provide a portable telephone set which can shut off the power supply for a display portion while a content of the display will not be seen during speaking, and thus can reduce power

consumption.”), 2:6-11 (“In the preferred construction the detector is a gyro. The control apparatus may shut off the power supply for the display when the detector detects the main body at a substantially vertical position. On the other hand, the control may initiate power supply for the display when the detector detects the main body at a substantially horizontal position.”); Perez at ¶ 0013 (“Referring to FIG. 1, a portable communication product 10 such as a cellular phone includes a transceiver radio having a microphone 20, an earpiece 22, a keypad 18 and a display 12 (such as a color display) coupled to the transceiver radio. The portable communication product 10 further includes at least one sensor (24, 26, 28 or 30) and a processor 16. The sensor can be used for detecting a user condition of the portable communication device such as a talk condition when the user is assumed to be talking on the portable communication device. The processor 16 can be programmed to at least reduce power provided to the display 12 when the sensor detects the talk condition. The processor 16 can also turn off power to the display 12 during a talk condition if desired.”). A person of ordinary skill in the art at the time of the alleged invention would be motivated to modify Miyashita to use “[t]he mobile station as recited in claim 1, wherein the proximity sensor is located proximate to the display” as disclosed in Perez for a number of different reasons, including that it would support Miyashita’s ability to conserve battery power in mobile stations, and doing so would be within the knowledge and ability of a person of ordinary skill in the art at the time of the alleged invention. The combination would constitute, at least, combining prior art elements according to known methods to yield predictable results, a simple substitution of one known element for another to obtain predictable results, the use of a known technique to improve similar devices in the same way, the application of a known technique to a known device ready for improvement to yield a predictable result, and obvious to try.

To the extent Miyashita is deemed to not expressly or inherently disclose “[t]he mobile station as recited in claim 1, wherein the proximity sensor is located proximate to the display,” it would be obvious to combine the disclosure of Miyashita with those of Seo as described in the Seo claim chart, which is incorporated herein in its entirety by reference. Miyashita and Seo are both directed to conserving battery power in mobile stations generally and more particularly at conserving battery power in mobile stations

by using sensors to detect when the user of the mobile station is in a call and unlikely to be looking at the display (as when, for example, the proximity sensor detects the user's ear by the mobile station or a sensor detects that the mobile station is in a vertical orientation) and to power off the display of mobile stations at such times. Miyashita at 1:58-63 (“The present invention is directed to solving the problem set forth above. It is therefore an object of the present invention to provide a portable telephone set which can shut off the power supply for a display portion while a content of the display will not be seen during speaking, and thus can reduce power consumption.”), 2:6-11 (“In the preferred construction the detector is a gyro. The control apparatus may shut off the power supply for the display when the detector detects the main body at a substantially vertical position. On the other hand, the control may initiate power supply for the display when the detector detects the main body at a substantially horizontal position.”); Seo at 1:36-42 (“It is hence a primary object of the invention to present a novel cordless telephone capable of, by solving the above mentioned technical problems, stopping the display action by the display device while the handset is in service so as to minimize the wasteful consumption of the electric power supplied from the battery or the like.”), 3:64-4:5 (When the receiver 6 is not in contact with the user's ear, the light emitting element 3 lights up at step n8. In this state, when the user touches the receiver 6 of the handset by the ear, it is detected by the piezoelectric element 7, and the detection signal is sent out to the control circuit 11. The control circuit 11, on the basis of this detection signal, sends out a stop signal to the driver 12. Thus, driving of the driver 12 is stopped, and the light emitting element 3 is extinguished at step n7.”). A person of ordinary skill in the art at the time of the alleged invention would be motivated to modify Miyashita to use “[t]he mobile station as recited in claim 1, wherein the proximity sensor is located proximate to the display,” as disclosed in Seo for a number of different reasons, including that it would support Miyashita's ability to conserve battery power in mobile stations, and doing so would be within the knowledge and ability of a person of ordinary skill in the art at the time of the alleged invention. The combination would constitute, at least, combining prior art elements according to known methods to yield predictable results, a simple substitution of one known element for another to obtain predictable results, the use of a known technique to improve similar devices in the same way, the application of a known

	<p>technique to a known device ready for improvement to yield a predictable result, and obvious to try.</p>
<p>[Claim 8 – Preamble] 8. A method of conserving battery power in a mobile station, comprising:</p>	<p>To the extent the preamble is construed as limiting, Miyashita discloses a method of conserving battery power in a mobile station:</p> <p>For example:</p> <p><i>See</i> discussion of claim 1, <i>supra</i>, which is incorporated herein by reference.</p> <p>“In contrast, the display control portion 17 is responsive to the inclination angle information indicative of variation of the inclination angle from the substantially horizontal orientation to the substantially vertical orientation while it performs display control for the display portion 16 to display the control information, to terminate the power supply for the display portion 16.</p> <p>When speaking is performed with the destination person via the speaker 12 and the microphone 14, it is rare to require seeing the display content on the display portion 16. Therefore, the power supply for the display portion 16 is shut down. Thus, exhausting of a battery can be reduced.” Miyashita at 3:58-4:2.</p> <p>“Thus, according to the shown embodiment, when the inclination angle information indicative that the main body is in a substantially horizontal orientation and when the reception control command from the reception control portion 2 and the call origination control command from the call origination control portion 3, the display control portion 17 starts the supply of the power. After speaking is started, when the inclination angle information indicative of a variation of orientation of the main body</p>

<p>[8a] detecting whether an external object is proximate;</p>	<p>from the horizontal position to the vertical position, the display control portion shuts off power supply for the display portion 16. Therefore, in the state of the portable telephone set in which the display portion 16 will not be seen, no power will be supplied to the display portion 16. Therefore, power consumption can be reduced. As well, it should serve for reducing the depletion of the battery.” Miyashita at 4:30-45.</p>
<p>[8a] detecting whether an external object is proximate;</p>	<p>Miyashita discloses detecting whether an external object is proximate:</p> <p>For example:</p> <p><i>See</i> discussion of claim element [1b], <i>supra</i>, which is incorporated herein by reference.</p> <p>To the extent Miyashita is deemed to not expressly disclose this claim limitation, Miyashita inherently discloses this limitation. <i>See</i> discussion of claim element [1b], <i>supra</i>, which is incorporated herein by reference.</p> <p>To the extent Miyashita is deemed to not expressly or inherently disclose this claim limitation, Miyashita renders it obvious to one of skill in the art at the time of the alleged invention. <i>See</i> discussion of claim element [1b], <i>supra</i>, which is incorporated herein by reference.</p> <p>To the extent Miyashita is deemed to not expressly or inherently disclose this claim element, it would be obvious to combine the disclosure of Miyashita with those of Numazawa as described in the Numazawa claim chart, which is incorporated herein in its entirety by reference. <i>See</i> discussion of claim element [1b], <i>supra</i>, which is incorporated herein by reference.</p> <p>To the extent Miyashita is deemed to not expressly or inherently disclose this claim element, it would be obvious to combine the disclosure of Miyashita with those of Perez as described in the Perez claim chart, which is incorporated herein in its entirety</p>

	<p>by reference. <i>See</i> discussion of claim element [1b], <i>supra</i>, which is incorporated herein by reference.</p> <p>To the extent Miyashita is deemed to not expressly or inherently disclose this claim element, it would be obvious to combine the disclosure of Miyashita with those of Seo as described in the Seo claim chart, which is incorporated herein in its entirety by reference. <i>See</i> discussion of claim element [1b], <i>supra</i>, which is incorporated herein by reference.</p>
<p>[8b] determining whether a telephone call is active; and</p>	<p>Miyashita discloses determining whether a telephone call is active:</p> <p>For example:</p> <p><i>See</i> discussion of claim element 1(d), <i>supra</i>, which is incorporated herein by reference.</p>
<p>[8c] reducing power consumption of a display of the mobile station if (i) a telephone call is determined to be active and (ii) the proximity of the external object is detected; wherein:</p>	<p>Miyashita discloses reducing power consumption of a display of the mobile station if (i) a telephone call is determined to be active and (ii) the proximity of the external object is detected:</p> <p>For example:</p> <p><i>See</i> discussion of claim element 1(f), <i>supra</i>, which is incorporated herein by reference.</p> <p>To the extent Miyashita is deemed to not expressly disclose this claim limitation, Miyashita inherently discloses this limitation. <i>See</i> discussion of claim element [1f], <i>supra</i>, which is incorporated herein by reference.</p>

	<p>To the extent Miyashita is deemed to not expressly or inherently disclose this claim limitation, Miyashita renders it obvious to one of skill in the art at the time of the alleged invention. <i>See</i> discussion of claim element [1f], <i>supra</i>, which is incorporated herein by reference.</p> <p>To the extent Miyashita is deemed to not expressly or inherently disclose this claim element, it would be obvious to combine the disclosure of Miyashita with those of Numazawa as described in the Numazawa claim chart, which is incorporated herein in its entirety by reference. <i>See</i> discussion of claim element [1f], <i>supra</i>, which is incorporated herein by reference.</p> <p>To the extent Miyashita is deemed to not expressly or inherently disclose this claim element, it would be obvious to combine the disclosure of Miyashita with those of Perez as described in the Perez claim chart, which is incorporated herein in its entirety by reference. <i>See</i> discussion of claim element [1f], <i>supra</i>, which is incorporated herein by reference.</p> <p>To the extent Miyashita is deemed to not expressly or inherently disclose this claim element, it would be obvious to combine the disclosure of Miyashita with those of Seo as described in the Seo claim chart, which is incorporated herein in its entirety by reference. <i>See</i> discussion of claim element [1f], <i>supra</i>, which is incorporated herein by reference.</p>
<p>[8d] the telephone call is a wireless telephone call;</p>	<p>Miyashita discloses that the telephone call is a wireless telephone call:</p> <p>For example:</p> <p><i>See</i> discussion of claim element 1 (g), <i>supra</i>, which is incorporated herein by reference.</p>

[8e] the power consumption of the display is reduced while the proximity of the external object is detected only if the wireless telephone call is determined to be active; and

Miyashita discloses that the power consumption of the display is reduced while the proximity of the external object is detected only if the wireless telephone call is determined to be active:

For example:

See discussion of claim element 1(f), *supra*, which is incorporated herein by reference.

To the extent Miyashita is deemed to not expressly disclose this claim limitation, Miyashita inherently discloses this limitation. *See* discussion of claim element [1f], *supra*, which is incorporated herein by reference.

To the extent Miyashita is deemed to not expressly or inherently disclose this claim limitation, Miyashita renders it obvious to one of skill in the art at the time of the alleged invention. *See* discussion of claim element [1f], *supra*, which is incorporated herein by reference.

To the extent Miyashita is deemed to not expressly or inherently disclose this claim element, it would be obvious to combine the disclosure of Miyashita with those of Numazawa as described in the Numazawa claim chart, which is incorporated herein in its entirety by reference. *See* discussion of claim element [1f], *supra*, which is incorporated herein by reference.

To the extent Miyashita is deemed to not expressly or inherently disclose this claim element, it would be obvious to combine the disclosure of Miyashita with those of Perez as described in the Perez claim chart, which is incorporated herein in its entirety by reference. *See* discussion of claim element [1f], *supra*, which is incorporated herein by reference.

To the extent Miyashita is deemed to not expressly or inherently disclose this claim element, it would be obvious to combine the disclosure of Miyashita with those of Seo as described in the Seo claim chart, which is incorporated herein in its entirety by

	<p>reference. <i>See</i> discussion of claim element [1f], <i>supra</i>, which is incorporated herein by reference.</p>
<p>[8f] detecting whether an external object is proximate begins substantially concurrently with the mobile station initiating an outgoing wireless telephone call or receiving an incoming wireless telephone call.</p>	<p>Miyashita discloses that detecting whether an external object is proximate begins substantially concurrently with the mobile station initiating an outgoing wireless telephone call or receiving an incoming wireless telephone call:</p> <p>For example:</p> <p><i>See</i> discussion of claim element 1(i), <i>supra</i>, which is incorporated herein by reference.</p> <p>To the extent Miyashita is deemed to not expressly disclose this claim limitation, Miyashita inherently discloses this limitation. <i>See</i> discussion of claim element [1i], <i>supra</i>, which is incorporated herein by reference.</p> <p>To the extent Miyashita is deemed to not expressly or inherently disclose this claim limitation, Miyashita renders it obvious to one of skill in the art at the time of the alleged invention. <i>See</i> discussion of claim element [1i], <i>supra</i>, which is incorporated herein by reference.</p> <p>To the extent Miyashita is deemed to not expressly or inherently disclose this claim element, it would be obvious to combine the disclosure of Miyashita with those of Numazawa as described in the Numazawa claim chart, which is incorporated herein in its entirety by reference. <i>See</i> discussion of claim element [1i], <i>supra</i>, which is incorporated herein by reference.</p> <p>To the extent Miyashita is deemed to not expressly or inherently disclose this claim element, it would be obvious to combine the disclosure of Miyashita with those of Perez as described in the Perez claim chart, which is incorporated herein in its entirety</p>

	<p>by reference. <i>See</i> discussion of claim element [1], <i>supra</i>, which is incorporated herein by reference.</p> <p>To the extent Miyashita is deemed to not expressly or inherently disclose this claim element, it would be obvious to combine the disclosure of Miyashita with those of Seo as described in the Seo claim chart, which is incorporated herein in its entirety by reference. <i>See</i> discussion of claim element [1], <i>supra</i>, which is incorporated herein by reference.</p>
<p>[Claim 12] The method as recited in claim 8, wherein the detecting of the proximity of the external object is performed by a mechanical proximity sensor, an optical sensor, or a range-detecting sensor.</p>	<p>Miyashita discloses that the detecting of the proximity of the external object is performed by a mechanical proximity sensor, an optical sensor, or a range-detecting sensor:</p> <p>For example:</p> <p><i>See</i> discussion of claim 5, <i>supra</i>, which is incorporated herein by reference.</p>

Exhibit A4

**Exhibit A4 - Seo
to Defendants' Preliminary Invalidity Contentions**

**Invalidity Chart for U.S. Patent No. 7,319,889
U.S. Patent No. 5,010,566 ("Seo")**

U.S. Patent No. 5,010,566 to Seo ("Seo") was filed on September 7, 1989 and issued on April 23, 1991. Seo is prior art to the '889 Patent under at least pre-AIA 35 U.S.C. §§ 102(a), 102(b), and 102(e). Seo anticipates or renders obvious, alone or in combination with other prior art references, each of the Asserted Claims of the '889 Patent as described in the chart below and in the main invalidity contentions document to which this chart is annexed.

It would have been obvious under 35 U.S.C. § 103 to a person having ordinary skill in the art at the time of the alleged invention to combine the teachings of Seo with the following references:

1. Japanese Unexamined Patent Application Publication No. 2000-106598 to Fukiharu ("Fukiharu 598"). Fukiharu 598 qualifies as prior art under at least pre-AIA §§ 102(a), 102(b), and 102(e). Fukiharu 598 was published on April 11, 2000.
2. Japanese Unexamined Patent Application Publication No. H11-220432 ("Numazawa"). Numazawa qualifies as prior art under at least pre-AIA §§ 102(a), 102(b), and 102(e). Numazawa was published on August 10, 1999.
3. U.S. Patent No. 5,586,182 to Miyashita ("Miyashita"). Miyashita qualifies as prior art under at least pre-AIA 35 U.S.C. § 102(e). Miyashita was filed on May 1, 1995 and issued on December 17, 1996.

<u>Asserted Claims</u>	<u>Corresponding Disclosure in the Prior Art Reference(s)</u>
[Claim 1 – Preamble] 1. A mobile station, comprising:	<p>Seo discloses a mobile station.</p> <p>For example: "A cordless telephone includes a base unit connected to a telephone line so as to communicate by radio waves for talking and a handset. The handset includes a speaker, a microphone, and a transmitting and receiving circuit for communicating with the base unit by radio waves, transforming the signals from the caller into acoustic sound by the speaker, and sending the output from the microphone to the caller. The handset further includes a battery for providing the transmitting and receiving circuit with electric power. Still further, the handset includes a device for display to indicate the in-service state, a device for detecting the contact of the speaker area with a part of the body, a device for detecting talking to detect the in-service state, and a device for controlling to stop the display action of the display device when the speaker area is in contact with a part of the body and is in service this stopping of the display device</p>

occurs response to the output from the contact detecting device and the talk detecting device. The control device further affects the display action by the display device while the speaker area is not in contact with the body during service. The handset, in this device, is electrically powered by a battery.” See at Abstract.

“The present invention relates to a cordless telephone having a base unit connected to a communication line such as telephone line, and a handset connected to the base unit by radio communication and furnished with a device for display so as to indicate that the handset is in service.” See at 1:6-12.

“The invention also relates to a cordless telephone having a base unit connected to a telephone line and a handset connected to the base unit through radio communication and equipped with a device for display so as to indicate the in-service state by the handset by the display device, which includes.” See at 2:16-22.

“FIG. 1 is a perspective view showing the entire structure of a cordless telephone 21 according to an embodiment of the invention. The cordless telephone 21 is connected to a telephone line 22, and include a handset 25 and a base unit 23 for radio communication therewith, the base unit 23 having an antenna 24 for radio communication with the handset 25. The handset 25 includes key switches 2 such as numeric keys as a dial input device provided inside the grip of a handset unit 1; a light emitting element 3 as a display device composed of a light emitting diode (LED) or the like disposed in the vicinity of the key switches 2 inside the grip; a disconnect or hang-up button 4 as the talk completion device for changing over between line capturing state and talk waiting state; a transmitter 5 with a microphone 14 built in and located near the mouth of the user; a receiver 6 containing a piezoelectric element 7 known as touch sensor or the like as the contact detecting device when contacting with the ear, that is, a part of the body of the user contacted while talking; an antenna 8 for communicating with the base unit 23; and a battery 28.” See at 3:1-22.

Fig 1

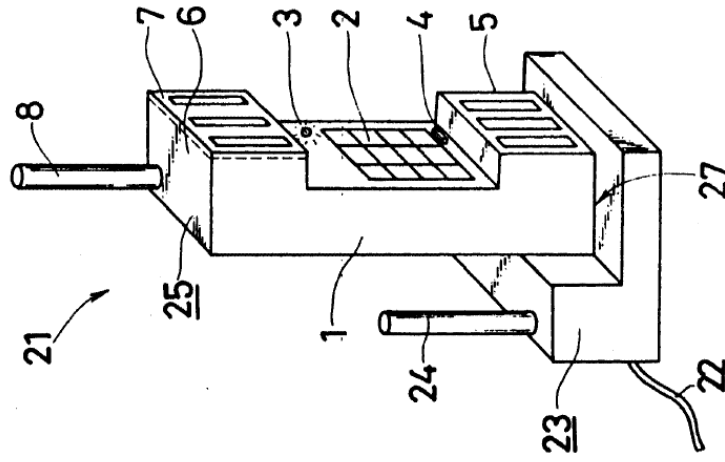

See at Fig. 1.

“FIG. 2 is a block diagram showing a schematic electrical construction of the cordless telephone 21.

In this diagram, a key signal by the operation of the key switch 2 is given to a control circuit 11 which is a device for controlling the members in the handset 25. It is also sent out from the antenna 8 through a transmitting and receiving circuit 13, and is

received through the antenna 24 of the base unit 23. It is then sent out to the telephone at the destination through the telephone line 22. Further, by the key signal from the key switch 2, the control circuit 11 sends out a drive signal to a driver 12 for lighting up the light emitting element 3. Thus, the driver 12 is driven to light up the light emitting element 3. In the meantime, a signal from the piezoelectric element 7 is applied to the control circuit 11, and a stop signal is sent out to the driver 12 from this piezoelectric element 7. Thus, driving of the driver 12 is stopped to extinguish the light emitting element 3. At the same time, the control circuit 11 sends out a control signal to the transmitting and receiving circuit 13. The transmitting and receiving circuit 13 amplifies and modulates the transmission signal received from a microphone 5 built in the transmitter 5. It then sends out a signal from the antenna 8, and demodulates and amplifies the reception signal sent from the antenna 23 through the telephone line 22 which is a communication circuit. Finally, it sends out a signal to a speaker 15 built in the receiver 6. Thus, an acoustic signal is delivered from the speaker 15. Such a handset 25 is electrically powered by a built-in battery 28." Seo at 3:23-52.

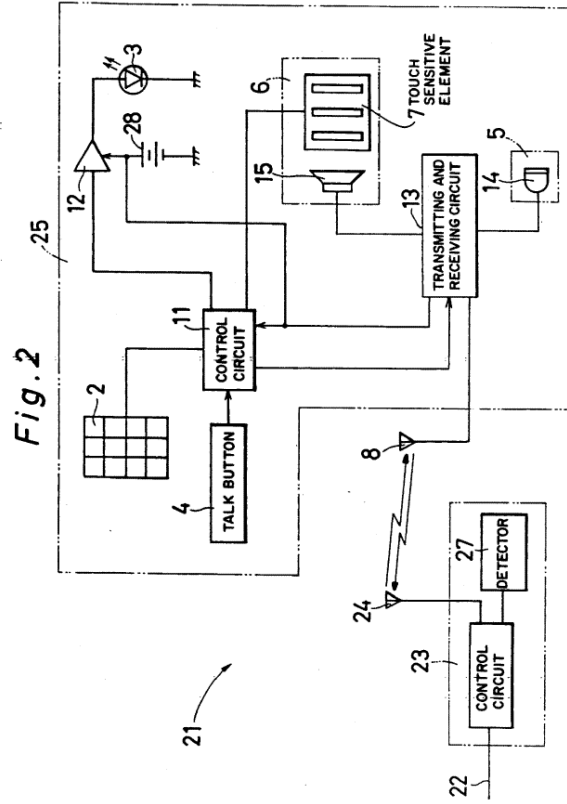

See at Fig. 2.

“1. A cordless telephone apparatus including a base unit connected to a telephone line for communication, and a handset, operatively connected to the base unit by radio waves, including a speaker, a microphone, a transmitting and receiving circuit for communicating with the base unit by radio waves, transforming the signals from a caller into acoustic sound by the speaker, and second the output from the microphone to the caller, and a battery for providing the transmitting and receiving circuit with electric power, the handset further comprising:

display means for indicating an in-service state of the cordless telephone activated for communication;

contact detecting means for detecting contact of a user with an area proximate to the speaker;

activation detecting means for detecting activation of the cordless telephone for communications to detect the in-service state; and

control means operatively connected to the display means, the contact detecting means and the activation detecting means, for controlling the display means to stop indicating an in-service state when an area proximate to the speaker is detected to be in contact with a user and an in service state is detected, in response to the contact detecting means and activation detecting means, and for controlling the display means to indicate an in-service state when an area proximate to the speaker is not detected to be in contact with a user and an in service state is detected; and

the handset battery means for electrically powering the handset.” Seo at claim 1.

“6. A cordless telephone apparatus including a base unit connected to a telephone line and a handset operatively connected to the base unit via radio communication and equipped with a display device for indicating an in-service state of the handset, the handset comprising:

contact detecting means for detecting contact when a part of the body of the user contacts with an area proximate to a speaker of the handset, and

stopping means for stopping the display device from indicating the in-service state when a part of the body of the user is detected to be in contact with an area proximate to the speaker of the handset, in response to the contact detecting means.” Seo at claim 6.

“7. A handset of a cordless telephone including a base unit and the handset including a speaker and a transmitter for communicating, by radio communications, with the base unit, the handset further comprising:

display means for displaying indication of the cordless telephone being in-service;

detecting means for emitting a signal upon detecting contact of a user to an area of the handset in close proximity to the speaker; and

control means, operatively connected to said display means and said detecting means, for controlling said display means to display indication of the cordless telephone being in-service upon not receiving an output signal from said detecting means when the cordless telephone is in service and for controlling said display means to stop displaying indication of the cordless telephone being in-service upon receiving an output signal from the detecting means when the cordless telephone is in service.” Seo at claim 7.

“16. A method of conserving power of a battery in a cordless telephone, including a handset with a battery, a speaker and a receiver and further including a base unit, which indicates to a user when the cordless telephone is in-service, comprising the steps of:

(a) displaying indication, on the handset, of the cordless telephone in-service;

(b) supplying power from the battery during said step (a) of displaying;

(c) detecting contact of a user to an area of the handset in close proximity to the speaker;

(d) inhibiting said step (a) of displaying by stopping said step (b) of supplying power upon detecting contact in step (c) to thus conserve battery power while said telephone is in-service.” Seo at claim 16.

To the extent Seo is deemed to not expressly disclose a mobile station, Seo inherently discloses this limitation. For example, as recognized in the 889 patent itself, “[m]obile stations have found many uses in today’s world. When paired with a single base station located at a user’s own premises, they are called ‘cordless telephones.’ When they interact with various, geographically distributed cellular base stations, they are called ‘cellular telephones’ or simply ‘cell phones.’” U.S. Patent No. 7,319,889 (“the ‘889 patent”). A person of ordinary skill in the art at the time of the alleged invention would understand that cordless telephone 21, as described in Seo, is necessarily a mobile station.

To the extent Seo is deemed to not expressly or inherently disclose a mobile station, Seo renders this limitation obvious to a person of ordinary skill in the art at the time of the alleged invention. Seo discloses a “cordless telephone” that “includes a base unit connected to a telephone line so as to communicate by radio waves....” Seo at Abstract. Furthermore, as recognized in the 889 patent itself, “[m]obile stations have found many uses in today’s world. When paired with a single base station located at a user’s own premises, they are called ‘cordless telephones.’ When they interact with various, geographically distributed cellular base stations, they are called ‘cellular telephones’ or simply ‘cell phones.’” U.S. Patent No. 7,319,889 (“the ‘889 patent”). Seo also discloses a method of conserving the battery power of the handset of the cordless phone. Seo at 1:36-42 (“It is hence a primary object of the invention to present a novel cordless telephone capable of, by solving the above mentioned technical problems, stopping the display action by the display device while the handset is in service so as to minimize the wasteful consumption of the electric power supplied from the battery or the like.”). It would therefore be obvious to a person of ordinary skill in the art at the time of the alleged invention to use Seo’s methods for conserving battery power for any type of mobile station (whether it be a “cordless telephone” or

“cellular telephone”). Such a combination would constitute, at least, combining prior art elements according to known methods to yield predictable results, a simple substitution of one known element for another to obtain predictable results, the use of a known technique to improve similar devices in the same way, the application of a known technique to a known device ready for improvement to yield a predictable result, and obvious to try.

To the extent Seo is deemed to not expressly or inherently disclose a “mobile station,” it would be obvious to combine the disclosure of Seo with those of Fukihara 598 as described in the Fukihara 598 claim chart, which is incorporated herein in its entirety by reference. Seo and Fukihara 598 are both directed to conserving battery power in mobile stations generally and more particularly at conserving battery power in mobile stations by using sensors to detect when the user of the mobile station is in a call and unlikely to be looking at the display (as when, for example, the proximity sensor detects the user’s ear by the mobile station) and to power off the display of mobile stations at such times. Seo at 1:36-42 (“It is hence a primary object of the invention to present a novel cordless telephone capable of, by solving the above mentioned technical problems, stopping the display action by the display device while the handset is in service so as to minimize the wasteful consumption of the electric power supplied from the battery or the like.”), 3:64-4:5 (When the receiver 6 is not in contact with the user’s ear, the light emitting element 3 lights up at step n8. In this state, when the user touches the receiver 6 of the handset by the ear, it is detected by the piezoelectric element 7, and the detection signal is sent out to the control circuit 11. The control circuit 11, on the basis of this detection signal, sends out a stop signal to the driver 12. Thus, driving of the driver 12 is stopped, and the light emitting element 3 is extinguished at step n7.”); Fukiharu 598 at ¶ 0018 (“The present invention, through the use of a structure as described above, enables a reduction in the consumption of battery power, through enabling the lighting devices to be turned OFF when the ear is caused to contact the receiver portion in order to hear the receiver sound during voice communications of a mobile telephone when the lighting devices (backlights) for a liquid crystal display device and keypad portion of a mobile telephone are lit, such as that night.”). A person of ordinary skill in the art at the time of the alleged invention

would be motivated to modify Seo to apply its battery conserving method to the mobile station disclosed in Fukihara 598 for a number of different reasons, including that it would support Seo's ability to conserve battery power in mobile stations, and doing so would be within the knowledge and ability of a person of ordinary skill in the art at the time of the alleged invention. The combination would constitute, at least, combining prior art elements according to known methods to yield predictable results, a simple substitution of one known element for another to obtain predictable results, the use of a known technique to improve similar devices in the same way, the application of a known technique to a known device ready for improvement to yield a predictable result, and obvious to try.

To the extent Seo is deemed to not expressly or inherently disclose a "mobile station," it would be obvious to combine the disclosure of Seo with those of Numazawa as described in the Numazawa claim chart, which is incorporated herein in its entirety by reference. Seo and Numazawa are both directed to conserving battery power in mobile stations generally and more particularly at conserving battery power in mobile stations by using sensors to detect when the user of the mobile station is in a call and unlikely to be looking at the display (as when, for example, the proximity sensor detects the user's ear by the mobile station) and to power off the display of mobile stations at such times. Seo at 1:36-42 ("It is hence a primary object of the invention to present a novel cordless telephone capable of, by solving the above mentioned technical problems, stopping the display action by the display device while the handset is in service so as to minimize the wasteful consumption of the electric power supplied from the battery or the like."), 3:64-4:5 (When the receiver 6 is not in contact with the user's ear, the light emitting element 3 lights up at step n8. In this state, when the user touches the receiver 6 of the handset by the ear, it is detected by the piezoelectric element 7, and the detection signal is sent out to the control circuit 11. The control circuit 11, on the basis of this detection signal, sends out a stop signal to the driver 12. Thus, driving of the driver 12 is stopped, and the light emitting element 3 is extinguished at step n7."); Numazawa at ¶ Abstract ("To achieve reduced power consumption through stopping operation of unnecessary functions during use of a wireless terminal. A CPU 2 identifies start of a call state through a signal from a signal processing portion 3 for

controlling communication with a base station, and identifies, through an output signal from detecting means 6, whether or not a user ear is in contact with a terminal. Upon identification of contact of the ear to the terminal, controlling means 8 are caused to stop the supply of electric power, from a power supply 7, to displaying means 9 for providing information to a user, and lighting means 10, such as a black light.”), ¶ 0005-0007 (“In the present invention, control is such that, upon determination that the wireless terminal is in a call, operation of functions believe be unnecessary, due to the user of the terminal being in a call, is stopped, and upon termination of the call, operation of the stopped functions is restarted. Additionally, because it is envisioned that there will also be cases where, even during a call, the face of the user may be separated from the receiver of the terminal, control is performed so as to enable restarting of the operations of the functions that had been stopped as unnecessary, through detecting whether or not the user of the terminal has the receiver in contact with an ear. The achievement of reduced power consumption through stopping operation of functions that become unnecessary in use of the terminal, as described above, can be anticipated to have the effect of extending the life of the power supply, such as a battery.”). A person of ordinary skill in the art at the time of the alleged invention would be motivated to modify Seo to apply its battery conserving method to the mobile station disclosed in Numazawa for a number of different reasons, including that it would support Seo’s ability to conserve battery power in mobile stations, and doing so would be within the knowledge and ability of a person of ordinary skill in the art at the time of the alleged invention. The combination would constitute, at least, combining prior art elements according to known methods to yield predictable results, a simple substitution of one known element for another to obtain predictable results, the use of a known technique to improve similar devices in the same way, the application of a known technique to a known device ready for improvement to yield a predictable result, and obvious to try.

To the extent Seo is deemed to not expressly or inherently disclose a “mobile station,” it would be obvious to combine the disclosure of Seo with those of Miyashita as described in the Miyashita claim chart, which is incorporated herein in its entirety by reference. Seo and Miyashita are both directed to conserving battery power in mobile

stations generally and more particularly at conserving battery power in mobile stations by using sensors to detect when the user of the mobile station is in a call and unlikely to be looking at the display (as when, for example, the proximity sensor detects the user's ear by the mobile station or a sensor detects that the mobile station is in a vertical orientation) and to power off the display of mobile stations at such times. Seo at 1:36-42 ("It is hence a primary object of the invention to present a novel cordless telephone capable of, by solving the above mentioned technical problems, stopping the display action by the display device while the handset is in service so as to minimize the wasteful consumption of the electric power supplied from the battery or the like."), 3:64-4:5 ("When the receiver 6 is not in contact with the user's ear, the light emitting element 3 lights up at step n8. In this state, when the user touches the receiver 6 of the handset by the ear, it is detected by the piezoelectric element 7, and the detection signal is sent out to the control circuit 11. The control circuit 11, on the basis of this detection signal, sends out a stop signal to the driver 12. Thus, driving of the driver 12 is stopped, and the light emitting element 3 is extinguished at step n7."); Miyashita at 1:58-63 ("The present invention is directed to solving the problem set forth above. It is therefore an object of the present invention to provide a portable telephone set which can shut off the power supply for a display portion while a content of the display will not be seen during speaking, and thus can reduce power consumption."), 2:6-11 ("In the preferred construction the detector is a gyro. The control apparatus may shut off the power supply for the display when the detector detects the main body at a substantially vertical position. On the other hand, the control may initiate power supply for the display when the detector detects the main body at a substantially horizontal position."). A person of ordinary skill in the art at the time of the alleged invention would be motivated to modify Seo to apply its battery conserving method to the mobile station disclosed in Miyashita for a number of different reasons, including that it would support Seo's ability to conserve battery power in mobile stations, and doing so would be within the knowledge and ability of a person of ordinary skill in the art at the time of the alleged invention. The combination would constitute, at least, combining prior art elements according to known methods to yield predictable results, a simple substitution of one known element for another to obtain predictable results, the use of a known technique to improve similar devices in the same way, the application of a known

	<p>technique to a known device ready for improvement to yield a predictable result, and obvious to try.</p>
<p>[1a] a display;</p>	<p>Seo discloses a display.</p> <p>For example: “Still further, the handset includes a device for display to indicate the in-service state, a device for detecting the contact of the speaker area with a part of the body, a device for detecting talking to detect the in-service state, and a device for controlling to stop the display action of the display device when the speaker area is in contact with a part of the body and is in service this stopping of the display device occurs response to the output from the contact detecting device and the talk detecting device. The control device further affects the display action by the display device while the speaker area is not in contact with the body during service. The handset, in this device, is electrically powered by a battery.” Seo at Abstract.</p> <p>“The present invention relates to a cordless telephone having a base unit connected to a communication line such as telephone line, and a handset connected to the base unit by radio communication and furnished with a device for display so as to indicate that the handset is in service.” Seo at 1:6-12.</p> <p>“In this case, therefore, the end of a call cannot be confirmed by the handset in the conventional method, and in the hitherto cordless telephone, a pilot lamp is built in the handset as the device for display. This lamp is lit while the handset is in service. Further, by pressing the disconnect or hang up button on the handset after the call is complete, the pilot lamp goes out.” Seo at 1:19-27.</p> <p>“It is hence a primary object of the invention to present a novel cordless telephone capable of, by solving the above mentioned technical problems, stopping the display action by the display device while the handset is in service so as to minimize the wasteful consumption of the electric power supplied from the battery or the like.” Seo at 1:36-42.</p>

“To achieve the above object, the cordless telephone of the invention comprises:

...

- (c1) a device for display to indicate the in-service state,
- (c2) a device for detecting the contact of the speaker area with a part of the body,
- (c3) a device for detecting the talk to detect the in-service state, and
- (c4) a device for controlling to stop the display action of the display a device when the speaker area is in contact with a part of the body and is in service, in response to the output from the contact detecting device and talk detecting device, and to effect the display action by the display device while the speaker area is not in contact with the body during service, and
- (c5) the handset is electrically powered by the battery.

Preferably, the display device is a light emitting diode.” Seo at 1:43-2:4.

“The invention also relates to a cordless telephone having a base unit connected to a telephone line and a handset connected to the base unit through radio communication and equipped with a device for display so as to indicate the in-service state by the handset by the display device, which includes:

...

a device for stopping the display to stop the display action by the display device when a part of the body of the user is in contact with the area proximate to the speaker of the handset, in response to the detection signal from the contact detecting device.

According to invention, when the contact of a part of the body of the user with an area proximate to the speaker of the handset is detected by the contact detecting device, the display action of the display device is stopped by the display stopping device while a part of the body of the user is in contact with the area proximate to the speaker of the

handset. When the part of the body of the user is departed from the area proximate to the speaker of the handset, the display action of the display device is affected again.

Thus, according to the cordless telephone of the invention, while talking, as long as a part of the body of the user remains in contact with the area proximate to the handset, the display action by the display device is not affected to display the in-service state, so that the consumption of the battery while the handset is in service can be minimized.”
See at 2:16-47.

“FIG. 1 is a perspective view showing the entire structure of a cordless telephone 21 according to an embodiment of the invention. The cordless telephone 21 is connected to a telephone line 22, and include a handset 25 and a base unit 23 for radio communication therewith, the base unit 23 having an antenna 24 for radio communication with the handset 25. The handset 25 includes key switches 2 such as numeric keys as a dial input device provided inside the grip of a handset unit 1; a light emitting element 3 as a display device composed of a light emitting diode (LED) or the like disposed in the vicinity of the key switches 2 inside the grip; a disconnect or hang-up button 4 as the talk completion device for changing over between line capturing state and talk waiting state; a transmitter 5 with a microphone 14 built in and located near the mouth of the user; a receiver 6 containing a piezoelectric element 7 known as touch sensor or the like as the contact detecting device when contacting with the ear, that is, a part of the body of the user contacted while talking; an antenna 8 for communicating with the base unit 23; and a battery 28.” See at 3:1-22.

“1. A cordless telephone apparatus including a base unit connected to a telephone line for communication, and a handset, operatively connected to the base unit by radio waves, including a speaker, a microphone, a transmitting and receiving circuit for communicating with the base unit by radio waves, transforming the signals from a caller into acoustic sound by the speaker, and second the output from the microphone to the caller, and a battery for providing the transmitting and receiving circuit with electric power, the handset further comprising:

display means for indicating an in-service state of the cordless telephone activated for communication;

contact detecting means for detecting contact of a user with an area proximate to the speaker;

activation detecting means for detecting activation of the cordless telephone for communications to detect the in-service state; and

control means operatively connected to the display means, the contact detecting means and the activation detecting means, for controlling the display means to stop indicating an in-service state when an area proximate to the speaker is detected to be in contact with a user and an in service state is detected, in response to the contact detecting means and activation detecting means, and for controlling the display means to indicate an in-service state when an area proximate to the speaker is not detected to be in contact with a user and an in service state is detected; and

the handset battery means for electrically powering the handset.” Seo at claim 1.

“2. The cordless telephone apparatus of claim 1, wherein the display means is a light emitting diode.” Seo at claim 2.

“7. A handset of a cordless telephone including a base unit and the handset including a speaker and a transmitter for communicating, by radio communications, with the base unit, the handset further comprising:

display means for displaying indication of the cordless telephone being in-service;

detecting means for emitting a signal upon detecting contact of a user to an area of the handset in close proximity to the speaker; and

control means, operatively connected to said display means and said detecting means, for controlling said display means to display indication of the cordless telephone being in-service upon not receiving an output signal from said detecting means when the cordless telephone is in service and for controlling said display means to stop displaying indication of the cordless telephone being in-service upon receiving an output signal from the detecting means when the cordless telephone is in service.” Seo at claim 7.

“10. The handset of claim 7, wherein the display means is a light emitting diode (LED).” Seo at claim 10.

“14. The handset of claim 7, further comprising:

end of service means, operatively connected to said control means, for outputting a signal to the control means to indicate that the cordless telephone is not in-service, and wherein said control means, upon receipt of said output signal from said end of service means, controls said display means to stop displaying indication of the cordless telephone being in service.

15. The handset of claim 7, further comprising:

battery means, operatively connected to said display means for providing power to enable said display means to display in-service indication.”

16. A method of conserving power of a battery in a cordless telephone, including a handset with a battery, a speaker and a receiver and further including a base unit, which indicates to a user when the cordless telephone is in-service, comprising the steps of:

(a) displaying indication, on the handset, of the cordless telephone in-service;

(b) supplying power from the battery during said step (a) of displaying;

(c) detecting contact of a user to an area of the handset in close proximity to the speaker;

(d) inhibiting said step (a) of displaying by stopping said step (b) of supplying power upon detecting contact in step (c) to thus conserve battery power while said telephone is in-service.” Seo at claims 14-16.

“17. The method of claim 16, further comprising the step of:

	<p>(e) terminating said step (a) of displaying upon said telephone not being in-service.” See at claim 17.</p>
<p>[1b] a proximity sensor adapted to generate a signal indicative of proximity of an external object; and</p>	<p>See discloses a proximity sensor adapted to generate a signal indicative of proximity of an external object.</p> <p>For example: “To achieve the above object, the cordless telephone of the invention comprises:</p> <p>...</p> <p>(c) the handset further comprises:</p> <p>(c1) a device for display to indicate the in-service state,</p> <p>(c2) a device for detecting the contact of the speaker area with a part of the body,</p> <p>(c3) a device for detecting the talk to detect the in-service state, and</p> <p>(c4) a device for controlling to stop the display action of the display a device when the speaker area is in contact with a part of the body and is in service, in response to the output from the contact detecting device and talk detecting device, and to effect the display action by the display device while the speaker area is not in contact with the body during service, and</p> <p>(c5) the handset is electrically powered by the battery.</p> <p>...</p> <p>Also preferably, the contact detecting device is a piezoelectric element.” See at 1:43-2:8.</p> <p>“The invention also relates to a cordless telephone having a base unit connected to a telephone line and a handset connected to the base unit through radio communication and equipped with a device for display so as to indicate the in-service state by the handset by the display device, which includes:</p>

a device for detecting contact when a part of the body of the user contacts an area proximate to the speaker, and

a device for stopping the display to stop the display action by the display device when a part of the body of the user is in contact with the area proximate to the speaker of the handset, in response to the detection signal from the contact detecting device.

According to invention, when the contact of a part of the body of the user with an area proximate to the speaker of the handset is detected by the contact detecting device, the display action of the display device is stopped by the display stopping device while a part of the body of the user is in contact with the area proximate to the speaker of the handset. When the part of the body of the user is departed from the area proximate to the speaker of the handset, the display action of the display device is affected again.

Thus, according to the cordless telephone of the invention, while talking, as long as a part of the body of the user remains in contact with the area proximate to the handset, the display action by the display device is not affected to display the in-service state, so that the consumption of the battery while the handset is in service can be minimized.”
See at 2:16-47.

“FIG. 1 is a perspective view showing the entire structure of a cordless telephone 21 according to an embodiment of the invention...a receiver 6 containing a piezoelectric element 7 known as touch sensor or the like as the contact detecting device when contacting with the ear, that is, a part of the body of the user contacted while talking; an antenna 8 for communicating with the base unit 23; and a battery 28.” See at 3:1-22.”

Fig 1

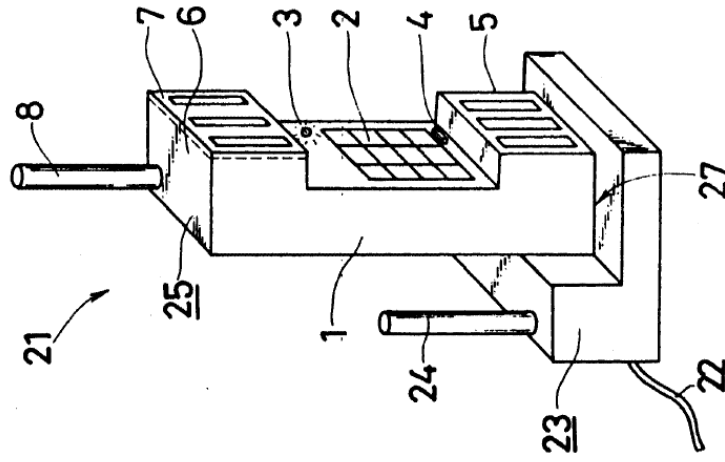

See at Fig. 1.

“FIG. 2 is a block diagram showing a schematic electrical construction of the cordless telephone 21.

In this diagram, a key signal by the operation of the key switch 2 is given to a control circuit 11 which is a device for controlling the members in the handset 25. It is also sent out from the antenna 8 through a transmitting and receiving circuit 13, and is

received through the antenna 24 of the base unit 23. It is then sent out to the telephone at the destination through the telephone line 22. Further, by the key signal from the key switch 2, the control circuit 11 sends out a drive signal to a driver 12 for lighting up the light emitting element 3. Thus, the driver 12 is driven to light up the light emitting element 3. In the meantime, a signal from the piezoelectric element 7 is applied to the control circuit 11, and a stop signal is sent out to the driver 12 from this piezoelectric element 7. Thus, driving of the driver 12 is stopped to extinguish the light emitting element 3. At the same time, the control circuit 11 sends out a control signal to the transmitting and receiving circuit 13. The transmitting and receiving circuit 13 amplifies and modulates the transmission signal received from a microphone 5 built in the transmitter 5. It then sends out a signal from the antenna 8, and demodulates and amplifies the reception signal sent from the antenna 23 through the telephone line 22 which is a communication circuit. Finally, it sends out a signal to a speaker 15 built in the receiver 6. Thus, an acoustic signal is delivered from the speaker 15. Such a handset 25 is electrically powered by a built-in battery 28." Seo at 3:23-52.

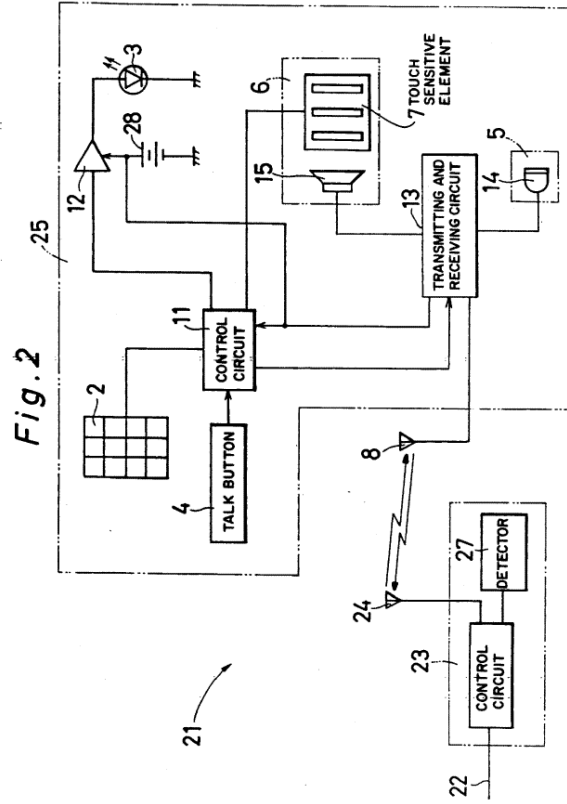

Seo at Fig. 2.

“At step n1 in FIG. 4, when the key switch 2 is operated and the telephone circuit 22 is connected at step n2, a drive signal is issued from the control circuit 11 to the driver 12. Further, when the talk button 4 is not pressed at step n3, the operation goes to step n5. Then when the line is busy, the operation advances to step n6. When the receiver 6 is not in contact with the user's ear, the light emitting element 3 lights up at step n8. In this state, when the user touches the receiver 6 of the handset by the ear, it is detected by the piezoelectric element 7, and the detection signal is sent out to the control circuit 11. The control circuit 11, on the basis of this detection signal, sends out a stop signal to the driver 12. Thus, driving of the driver 12 is stopped, and the light emitting element 3 is extinguished at step n7. Afterwards, when the user's ear is departed again from the piezoelectric element 7, the control circuit 11 then sends out a drive signal to the driver 12 to drive the driver 12. This thereby lights the light emitting element 3 again. Afterwards, by pressing the hang-up button 4 at step n3, a communication circuit cut-off signal is sent out from the handset 25 to the base unit 23 at step n4. Thus the base unit 23 receives the communication circuit signal at step m4 in FIG. 3. Then the connection with the telephone line 22 is cut off at step m5, so that the light emitting element 3 of the handset 25 goes out.” See at 3:59-4:16.

Fig. 3

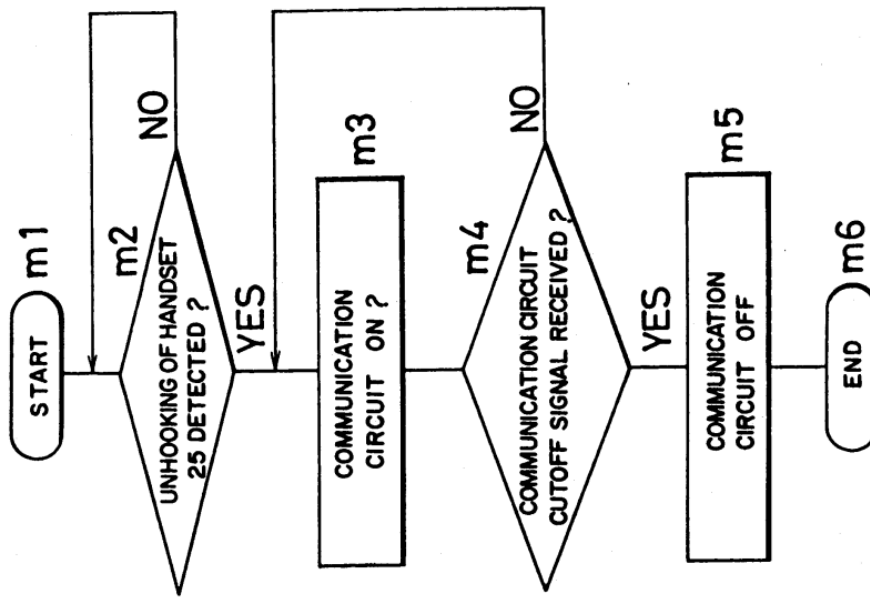

See at Fig. 3.

Fig. 4

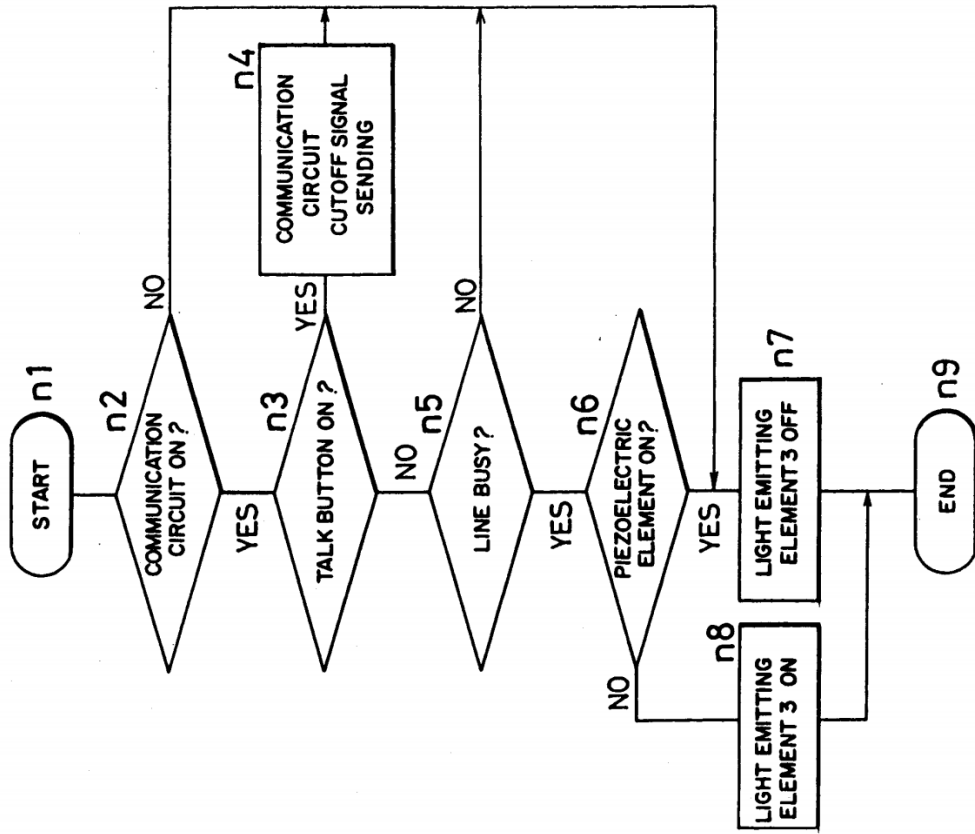

See at Fig. 4.

“1. A cordless telephone apparatus including a base unit connected to a telephone line for communication, and a handset, operatively connected to the base unit by radio waves, including a speaker, a microphone, a transmitting and receiving circuit for communicating with the base unit by radio waves, transforming the signals from a caller into acoustic sound by the speaker, and second the output from the microphone to the caller, and a battery for providing the transmitting and receiving circuit with electric power, the handset further comprising:

display means for indicating an in-service state of the cordless telephone activated for communication;

contact detecting means for detecting contact of a user with an area proximate to the speaker;

activation detecting means for detecting activation of the cordless telephone for communications to detect the in-service state; and

control means operatively connected to the display means, the contact detecting means and the activation detecting means, for controlling the display means to stop indicating an in-service state when an area proximate to the speaker is detected to be in contact with a user and an in service state is detected, in response to the contact detecting means and activation detecting means, and for controlling the display means to indicate an in-service state when an area proximate to the speaker is not detected to be in contact with a user and an in service state is detected; and

the handset battery means for electrically powering the handset.” Seo at claim 1.

“ 3. The cordless telephone apparatus of claim 1, wherein the contact detecting means is a piezoelectric element.” Seo at claim 3.

“5. The cordless telephone apparatus of claim 1, wherein the contact detecting means includes a penetration hole in an area proximate to the speaker, the speaker being disposed behind the contact detecting means.” Seo at claim 5.

<p>“6. A cordless telephone apparatus including a base unit connected to a telephone line and a handset operatively connected to the base unit via radio communication and equipped with a display device for indicating an in-service state of the handset, the handset comprising:</p> <p>contact detecting means for detecting contact when a part of the body of the user contacts with an area proximate to a speaker of the handset, and</p> <p>stopping means for stopping the display device from indicating the in-service state when a part of the body of the user is detected to be in contact with an area proximate to the speaker of the handset, in response to the contact detecting means.” See at claim 6.</p> <p>“7. A handset of a cordless telephone including a base unit and the handset including a speaker and a transmitter for communicating, by radio communications, with the base unit, the handset further comprising:</p> <p>display means for displaying indication of the cordless telephone being in-service;</p> <p>detecting means for emitting a signal upon detecting contact of a user to an area of the handset in close proximity to the speaker; and</p> <p>control means, operatively connected to said display means and said detecting means, for controlling said display means to display indication of the cordless telephone being in-service upon not receiving an output signal from said detecting means when the cordless telephone is in service and for controlling said display means to stop displaying indication of the cordless telephone being in-service upon receiving an output signal from the detecting means when the cordless telephone is in service.” See at claim 7.</p> <p>“9. The handset of claim 7, wherein the detecting means is a piezoelectric element and the piezoelectric element is disposed in close proximity to the speaker.” See at claim 9.</p> <p>“12. The handset of claim 11, wherein the detecting means is a piezoelectric element disposed in close proximity to the speaker.</p>	
---	--

13. The handset of claim 12, wherein the piezoelectric element detects contact of the user's ear to the handset, proximate to the speaker, and outputs a signal." Seo at claims 12-13.

"16. A method of conserving power of a battery in a cordless telephone, including a handset with a battery, a speaker and a receiver and further including a base unit, which indicates to a user when the cordless telephone is in-service, comprising the steps of:

(a) displaying indication, on the handset, of the cordless telephone in-service;

(b) supplying power from the battery during said step (a) of displaying;

(c) detecting contact of a user to an area of the handset in close proximity to the speaker;

(d) inhibiting said step (a) of displaying by stopping said step (b) of supplying power upon detecting contact in step (c) to thus conserve battery power while said telephone is in-service." Seo at claim 17.

"18. The method of claim 16, wherein said step (c) of detecting contact detects contact of a user's ear to an area of the handset in close proximity to the speaker." Seo at claim 18.

To the extent Seo is deemed to not expressly disclose "a proximity sensor adapted to generate a signal indicative of proximity of an external object," a person of skill would understand that this claim element is inherent in Seo's disclosure. Specifically, in disclosing "a device for stopping the display to stop the display action by the display device when a part of the body of the user is in contact with the area proximate to the speaker of the handset, in response to the detection signal from the contact detecting device," Seo necessarily discloses generating a signal indicative of proximity of an external object. *See* Seo at 2:25-29.

<p>[1c] a microprocessor adapted to:</p>	<p>Seo discloses a microprocessor.</p> <p>For example: “A cordless telephone includes a base unit connected to a telephone line so as to communicate by radio waves for talking and a handset. The handset includes a speaker, a microphone, and a transmitting and receiving circuit for communicating with the base unit by radio waves, transforming the signals from the caller into acoustic sound by the speaker, and sending the output from the microphone to the caller. The handset further includes a battery for providing the transmitting and receiving circuit with electric power. Still further, the handset includes a device for display to indicate the in-service state, a device for detecting the contact of the speaker area with a part of the body, a device for detecting talking to detect the in-service state, and a device for controlling to stop the display action of the display device when the speaker area is in contact with a part of the body and is in service this stopping of the display device occurs response to the output from the contact detecting device and the talk detecting device. The control device further affects the display action by the display device while the speaker area is not in contact with the body during service. The handset, in this device, is electrically powered by a battery.” Seo at Abstract.</p> <p>“FIG. 2 is a block diagram showing a schematic electrical construction of the cordless telephone 21.</p> <p>In this diagram, a key signal by the operation of the key switch 2 is given to a control circuit 11 which is a device for controlling the members in the handset 25. It is also sent out from the antenna 8 through a transmitting and receiving circuit 13, and is received through the antenna 24 of the base unit 23. It is then sent out to the telephone at the destination through the telephone line 22. Further, by the key signal from the key switch 2, the control circuit 11 sends out a drive signal to a driver 12 for lighting up the light emitting element 3. Thus, the driver 12 is driven to light up the light emitting element 3. In the meantime, a signal from the piezoelectric element 7 is applied to the control circuit 11, and a stop signal is sent out to the driver 12 from this piezoelectric element 7. Thus, driving of the driver 12 is stopped to extinguish the light emitting element 3. At the same time, the control circuit 11 sends out a control signal to the transmitting and receiving circuit 13. The transmitting and receiving circuit 13 amplifies</p>
--	---

and modulates the transmission signal received from a microphone 14 built in the transmitter 5. It then sends out a signal from the antenna 8, and demodulates and amplifies the reception signal sent from the base unit 23 through the telephone line 22 which is a communication circuit. Finally, it sends out a signal to a speaker 15 built in the receiver 6. Thus, an acoustic signal is delivered from the speaker 15 built in 25 is electrically powered by a built-in battery 28." Seo at 3:23-52.

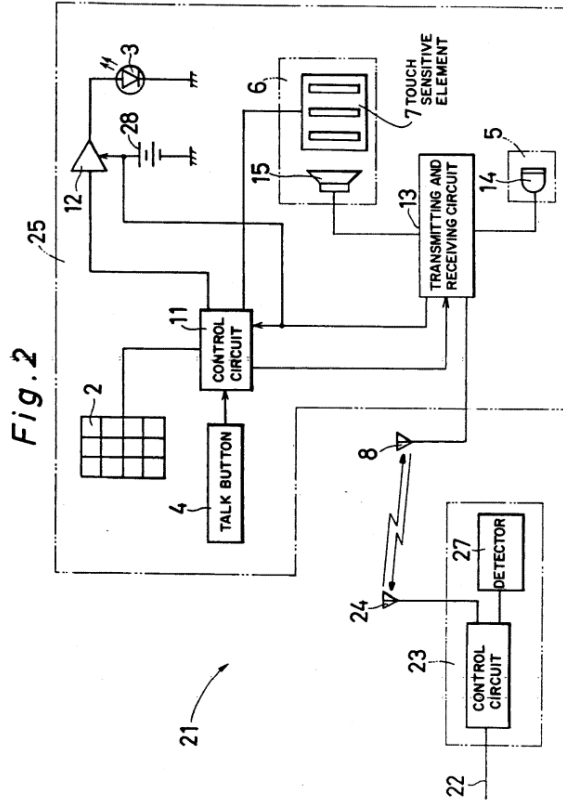

See at Fig. 2.

“At step n1 in FIG. 4, when the key switch 2 is operated and the telephone circuit 22 is connected at step n2, a drive signal is issued from the control circuit 11 to the driver 12. Further, when the talk button 4 is not pressed at step n3, the operation goes to step n5. Then when the line is busy, the operation advances to step n6. When the receiver 6 is not in contact with the user's ear, the light emitting element 3 lights up at step n8. In this state, when the user touches the receiver 6 of the handset by the ear, it is detected by the piezoelectric element 7, and the detection signal is sent out to the control circuit 11. The control circuit 11, on the basis of this detection signal, sends out a stop signal to the driver 12. Thus, driving of the driver 12 is stopped, and the light emitting

element 3 is extinguished at step n7. Afterwards, when the user's ear is departed again from the piezoelectric element 7, the control circuit 11 then sends out a drive signal to the driver 12 to drive the driver 12. This thereby lights the light emitting element 3 again. Afterwards, by pressing the hang-up button 4 at step n3, a communication circuit cut-off signal is sent out from the handset 25 to the base unit 23 at step n4. Thus the base unit 23 receives the communication circuit signal at step m4 in FIG. 3. Then the connection with the telephone line 22 is cut off at step m5, so that the light emitting element 3 of the handset 25 goes out." See at 3:59-4:17.

"1. A cordless telephone apparatus including a base unit connected to a telephone line for communication, and a handset, operatively connected to the base unit by radio waves, including a speaker, a microphone, a transmitting and receiving circuit for communicating with the base unit by radio waves, transforming the signals from a caller into acoustic sound by the speaker, and second the output from the microphone to the caller, and a battery for providing the transmitting and receiving circuit with electric power, the handset further comprising:

display means for indicating an in-service state of the cordless telephone activated for communication;

contact detecting means for detecting contact of a user with an area proximate to the speaker;

activation detecting means for detecting activation of the cordless telephone for communications to detect the in-service state; and

control means operatively connected to the display means, the contact detecting means and the activation detecting means, for controlling the display means to stop indicating an in-service state when an area proximate to the speaker is detected to be in contact with a user and an in service state is detected, in response to the contact detecting means and activation detecting means, and for controlling the display means to indicate an in-service state when an area proximate to the speaker is not detected to be in contact with a user and an in service state is detected; and

the handset battery means for electrically powering the handset.” Seo at claim 1.

“7. A handset of a cordless telephone including a base unit and the handset including a speaker and a transmitter for communicating, by radio communications, with the base unit, the handset further comprising:

display means for displaying indication of the cordless telephone being in-service;

detecting means for emitting a signal upon detecting contact of a user to an area of the handset in close proximity to the speaker; and

control means, operatively connected to said display means and said detecting means, for controlling said display means to display indication of the cordless telephone being in-service upon not receiving an output signal from said detecting means when the cordless telephone is in service and for controlling said display means to stop displaying indication of the cordless telephone being in-service upon receiving an output signal from the detecting means when the cordless telephone is in service.” Seo at claim 7.

To the extent Seo is deemed to not expressly disclose a “microprocessor adapted to,” Seo inherently discloses this limitation. Seo discloses a mobile station with a control circuit 11. Microprocessors (such as the ARM7TDMI) were widely implemented in mobile stations at the time of the alleged invention as a control means. *See, e.g., S. Segars, “The ARM9 family—high performance microprocessors for embedded applications”, Proc. ICCD, pp. 230-235, 1998-Oct.* A person of ordinary skill in the art at the time of the alleged invention would therefore understand Seo to necessarily disclose a “microprocessor adapted to.”

To the extent Seo is deemed to not expressly or inherently disclose “a microprocessor adapted to,” Seo renders it obvious to one of skill in the art to use “a microprocessor adapted to.” A person of ordinary skill in the art at the time of the alleged invention would understand that the functionality of the control circuit 11 of Seo could be

implemented using a microprocessor such as the ARM7TDMI. *See, e.g.,* S. Segars, “The ARM9 family-high performance microprocessors for embedded applications”, Proc. ICCD, pp. 230-235, 1998-Oct. Doing so would be a design choice driven by a number of different reasons, including that it would support Seo’s ability to conserve battery power in mobile stations, and doing so would be within the knowledge and ability of a person of ordinary skill in the art at the time of the alleged invention. The use of a microprocessor would constitute, at least, combining prior art elements according to known methods to yield predictable results, a simple substitution of one known element for another to obtain predictable results, the use of a known technique to improve similar devices in the same way, the application of a known technique to a known device ready for improvement to yield a predictable result, and obvious to try.

To the extent Seo is deemed to not expressly or inherently disclose “a microprocessor adapted to,” it would be obvious to combine the disclosure of Seo with those of Fukihara 598 as described in the Fukihara 598 claim chart, which is incorporated herein in its entirety by reference. Seo and Fukihara 598 are both directed to conserving battery power in mobile stations generally and more particularly at conserving battery power in mobile stations by using sensors to detect when the user of the mobile station is in a call and unlikely to be looking at the display (as when, for example, the proximity sensor detects the user’s ear by the mobile station) and to power off the display of mobile stations at such times. Seo at 1:36-42 (“It is hence a primary object of the invention to present a novel cordless telephone capable of, by solving the above mentioned technical problems, stopping the display action by the display device while the handset is in service so as to minimize the wasteful consumption of the electric power supplied from the battery or the like.”), 3:64-4:5 (When the receiver 6 is not in contact with the user’s ear, the light emitting element 3 lights up at step n8. In this state, when the user touches the receiver 6 of the handset by the ear, it is detected by the piezoelectric element 7, and the detection signal is sent out to the control circuit 11. The control circuit 11, on the basis of this detection signal, sends out a stop signal to the driver 12. Thus, driving of the driver 12 is stopped, and the light emitting element 3 is extinguished at step n7.”); Fukiharu 598 at ¶ 0018 (“The present invention, through the use of a structure as described above, enables a reduction in the consumption of

battery power, through enabling the lighting devices to be turned OFF when the ear is caused to contact the receiver portion in order to hear the receiver sound during voice communications of a mobile telephone when the lighting devices (backlights) for a liquid crystal display device and keypad portion of a mobile telephone are lit, such as that night.”). A person of ordinary skill in the art at the time of the alleged invention would be motivated to modify Seo to use “a microprocessor adapted to” as disclosed in Fukihara 598 for a number of different reasons, including that it would support Seo’s ability to conserve battery power in mobile stations, and doing so would be within the knowledge and ability of a person of ordinary skill in the art at the time of the alleged invention. The combination would constitute, at least, combining prior art elements according to known methods to yield predictable results, a simple substitution of one known element for another to obtain predictable results, the use of a known technique to improve similar devices in the same way, the application of a known technique to a known device ready for improvement to yield a predictable result, and obvious to try.

To the extent Seo is deemed to not expressly or inherently disclose a “a microprocessor adapted to,” it would be obvious to combine the disclosure of Seo with those of Numazawa as described in the Numazawa claim chart, which is incorporated herein in its entirety by reference. Seo and Numazawa are both directed to conserving battery power in mobile stations generally and more particularly at conserving battery power in mobile stations by using sensors to detect when the user of the mobile station is in a call and unlikely to be looking at the display (as when, for example, the proximity sensor detects the user’s ear by the mobile station) and to power off the display of mobile stations at such times. Seo at 1:36-42 (“It is hence a primary object of the invention to present a novel cordless telephone capable of, by solving the above mentioned technical problems, stopping the display action by the display device while the handset is in service so as to minimize the wasteful consumption of the electric power supplied from the battery or the like.”), 3:64-4:5 (When the receiver 6 is not in contact with the user’s ear, the light emitting element 3 lights up at step n8. In this state, when the user touches the receiver 6 of the handset by the ear, it is detected by the piezoelectric element 7, and the detection signal is sent out to the control circuit 11. The control circuit 11, on the basis of this detection signal, sends out a stop signal to

the driver 12. Thus, driving of the driver 12 is stopped, and the light emitting element 3 is extinguished at step n7.”); Numazawa at ¶ Abstract (“To achieve reduced power consumption through stopping operation of unnecessary functions during use of a wireless terminal. A CPU 2 identifies start of a call state through a signal from a signal processing portion 3 for controlling communication with a base station, and identifies, through an output signal from detecting means 6, whether or not a user ear is in contact with a terminal. Upon identification of contact of the ear to the terminal, controlling means 8 are caused to stop the supply of electric power, from a power supply 7, to displaying means 9 for providing information to a user, and lighting means 10, such as a black light.”), ¶ 0005-0007 (“In the present invention, control is such that, upon determination that the wireless terminal is in a call, operation of functions believe be unnecessary, due to the user of the terminal being in a call, is stopped, and upon termination of the call, operation of the stopped functions is restarted. Additionally, because it is envisioned that there will also be cases where, even during a call, the face of the user may be separated from the receiver of the terminal, control is performed so as to enable restarting of the operations of the functions that had been stopped as unnecessary, through detecting whether or not the user of the terminal has the receiver in contact with an ear. The achievement of reduced power consumption through stopping operation of functions that become unnecessary in use of the terminal, as described above, can be anticipated to have the effect of extending the life of the power supply, such as a battery.”). A person of ordinary skill in the art at the time of the alleged invention would be motivated to modify Seo to use “a microprocessor adapted to” as disclosed in Numazawa for a number of different reasons, including that it would support Seo’s ability to conserve battery power in mobile stations, and doing so would be within the knowledge and ability of a person of ordinary skill in the art at the time of the alleged invention. The combination would constitute, at least, combining prior art elements according to known methods to yield predictable results, a simple substitution of one known element for another to obtain predictable results, the use of a known technique to improve similar devices in the same way, the application of a known technique to a known device ready for improvement to yield a predictable result, and obvious to try.

To the extent Seo is deemed to not expressly or inherently disclose a “mobile station,” it would be obvious to combine the disclosure of Seo with those of Miyashita as described in the Miyashita claim chart, which is incorporated herein in its entirety by reference. Seo and Miyashita are both directed to conserving battery power in mobile stations generally and more particularly at conserving battery power in mobile stations by using sensors to detect when the user of the mobile station is in a call and unlikely to be looking at the display (as when, for example, the proximity sensor detects the user’s ear by the mobile station or a sensor detects that the mobile station is in a vertical orientation) and to power off the display of mobile stations at such times. Seo at 1:36-42 (“It is hence a primary object of the invention to present a novel cordless telephone capable of, by solving the above mentioned technical problems, stopping the display action by the display device while the handset is in service so as to minimize the wasteful consumption of the electric power supplied from the battery or the like.”), 3:64-4:5 (“When the receiver 6 is not in contact with the user’s ear, the light emitting element 3 lights up at step n8. In this state, when the user touches the receiver 6 of the handset by the ear, it is detected by the piezoelectric element 7, and the detection signal is sent out to the control circuit 11. The control circuit 11, on the basis of this detection signal, sends out a stop signal to the driver 12. Thus, driving of the driver 12 is stopped, and the light emitting element 3 is extinguished at step n7.”); Miyashita at 1:58-63 (“The present invention is directed to solving the problem set forth above. It is therefore an object of the present invention to provide a portable telephone set which can shut off the power supply for a display portion while a content of the display will not be seen during speaking, and thus can reduce power consumption.”), 2:6-11 (“In the preferred construction the detector is a gyro. The control apparatus may shut off the power supply for the display when the detector detects the main body at a substantially vertical position. On the other hand, the control may initiate power supply for the display when the detector detects the main body at a substantially horizontal position.”). A person of ordinary skill in the art at the time of the alleged invention would be motivated to modify Seo to use “a microprocessor adapted to” as disclosed in Miyashita for a number of different reasons, including that it would support Seo’s ability to conserve battery power in mobile stations, and doing so would be within the knowledge and ability of a person of ordinary skill in the art at the time of the alleged invention. The combination would constitute, at least, combining prior art elements according to known methods to yield predictable results, a simple substitution of one

	<p>known element for another to obtain predictable results, the use of a known technique to improve similar devices in the same way, the application of a known technique to a known device ready for improvement to yield a predictable result, and obvious to try.</p>
<p>[1d] (a) determine whether a telephone call is active;</p>	<p>Seo discloses the microprocessor adapted to determine whether a telephone call is active.</p> <p>For example: “CORDLESS TELEPHONE.” Seo at Title.</p> <p>“A cordless telephone includes a base unit connected to a telephone line so as to communicate by radio waves for talking and a handset. The handset includes a speaker, a microphone, and a transmitting and receiving circuit for communicating with the base unit by radio waves, transforming the signals from the caller into acoustic sound by the speaker, and sending the output from the microphone to the caller. The handset further includes a battery for providing the transmitting and receiving circuit with electric power. Still further, the handset includes a device for display to indicate the in-service state, a device for detecting the contact of the speaker area with a part of the body, a device for detecting talking to detect the in-service state, and a device for controlling to stop the display action of the display device when the speaker area is in contact with a part of the body and is in service this stopping of the display device occurs response to the output from the contact detecting device and the talk detecting device. The control device further affects the display action by the display device while the speaker area is not in contact with the body during service. The handset, in this device, is electrically powered by a battery.” Seo at Abstract.</p> <p>“To achieve the above object, the cordless telephone of the invention comprises:</p> <p>(a) a base unit connected to a telephone line so as to communicate by radio waves for talking, and</p> <p>(b) a handset comprising:</p>

(b1) a speaker,

(b2) a microphone,

(b3) a transmitting and receiving circuit for communicating with the base unit by radio waves, transforming the signals from the caller into acoustic sound in the speaker, and sending the output from the microphone to the caller, and

(b4) a battery for providing the transmitting and receiving circuit with electric power, wherein

(c) the handset further comprises:

(c1) a device for display to indicate the in-service state,

...

(c3) a device for detecting the talk to detect the in-service state, and

(c4) a device for controlling to stop the display action of the display a device when the speaker area is in contact with a part of the body and is in service, in response to the output from the contact detecting device and talk detecting device, and to effect the display action by the display device while the speaker area is not in contact with the body during service,” Seo at 1:43-64.

“The invention also relates to a cordless telephone having a base unit connected to a telephone line and a handset connected to the base unit through radio communication and equipped with a device for display so as to indicate the in-service state by the handset by the display device, which includes:...” Seo at 2:16-21.

“FIG. 1 is a perspective view showing the entire structure of a cordless telephone 21 according to an embodiment of the invention. The cordless telephone 21 is connected to a telephone line 22, and include a handset 25 and a base unit 23 for radio communication therewith, the base unit 23 having an antenna 24 for radio communication with the handset 25. The handset 25 includes key switches 2 such as

“FIG. 2 is a block diagram showing a schematic electrical construction of the cordless telephone 21.

In this diagram, a key signal by the operation of the key switch 2 is given to a control circuit 11 which is a device for controlling the members in the handset 25. It is also sent out from the antenna 8 through a transmitting and receiving circuit 13, and is received through the antenna 24 of the base unit 23. It is then sent out to the telephone at the destination through the telephone line 22. Further, by the key signal from the key switch 2, the control circuit 11 sends out a drive signal to a driver 12 for lighting up the light emitting element 3. Thus, the driver 12 is driven to light up the light emitting element 3.... At the same time, the control circuit 11 sends out a control signal to the transmitting and receiving circuit 13. The transmitting and receiving circuit 13 amplifies and modulates the transmission signal received from a microphone 14 built in the transmitter 5. It then sends out a signal from the antenna 8, and demodulates and amplifies the reception signal sent from the base unit 23 through the telephone line 22 which is a communication circuit. Finally, it sends out a signal to a speaker 15 built in the receiver 6. Thus, an acoustic signal is delivered from the speaker 15. Such a handset 25 is electrically powered by a built-in battery 28.” See at 3:23-52.

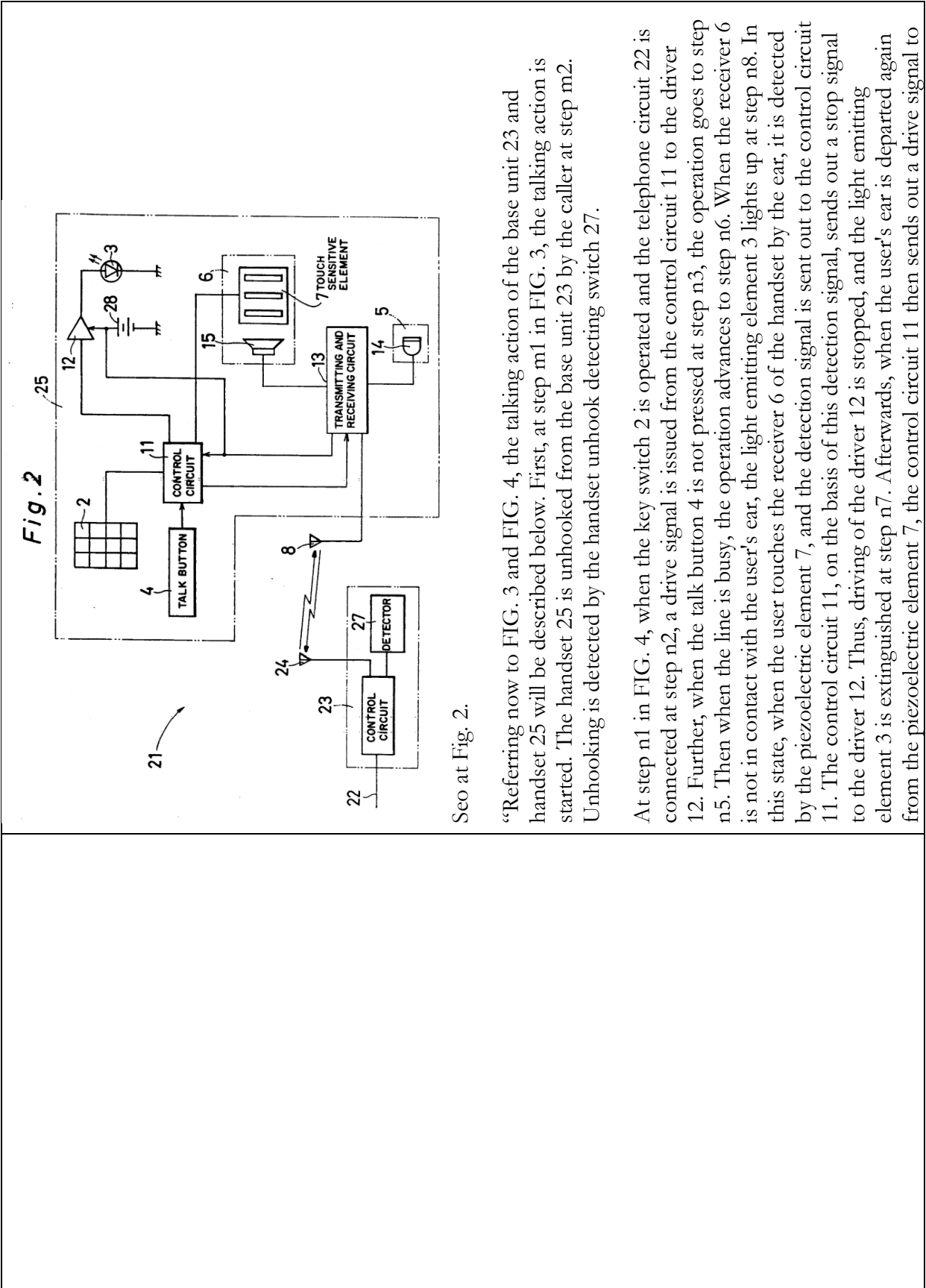

Fig. 2

See at Fig. 2.

“Referring now to FIG. 3 and FIG. 4, the talking action of the base unit 23 and handset 25 will be described below. First, at step m1 in FIG. 3, the talking action is started. The handset 25 is unhooked from the base unit 23 by the caller at step m2. Unhooking is detected by the handset unhook detecting switch 27.

At step n1 in FIG. 4, when the key switch 2 is operated and the telephone circuit 22 is connected at step n2, a drive signal is issued from the control circuit 11 to the driver 12. Further, when the talk button 4 is not pressed at step n3, the operation goes to step n5. Then when the line is busy, the operation advances to step n6. When the receiver 6 is not in contact with the user's ear, the light emitting element 3 lights up at step n8. In this state, when the user touches the receiver 6 of the handset by the ear, it is detected by the piezoelectric element 7, and the detection signal is sent out to the control circuit 11. The control circuit 11, on the basis of this detection signal, sends out a stop signal to the driver 12. Thus, driving of the driver 12 is stopped, and the light emitting element 3 is extinguished at step n7. Afterwards, when the user's ear is departed again from the piezoelectric element 7, the control circuit 11 then sends out a drive signal to

the driver 12 to drive the driver 12. This thereby lights the light emitting element 3 again. Afterwards, by pressing the hang-up button 4 at step n3, a communication circuit cut-off signal is sent out from the handset 25 to the base unit 23 at step n4. Thus the base unit 23 receives the communication circuit signal at step m4 in FIG. 3. Then the connection with the telephone line 22 is cut off at step m5, so that the light emitting element 3 of the handset 25 goes out.” Seo at 3:53-4:16.

Fig. 3

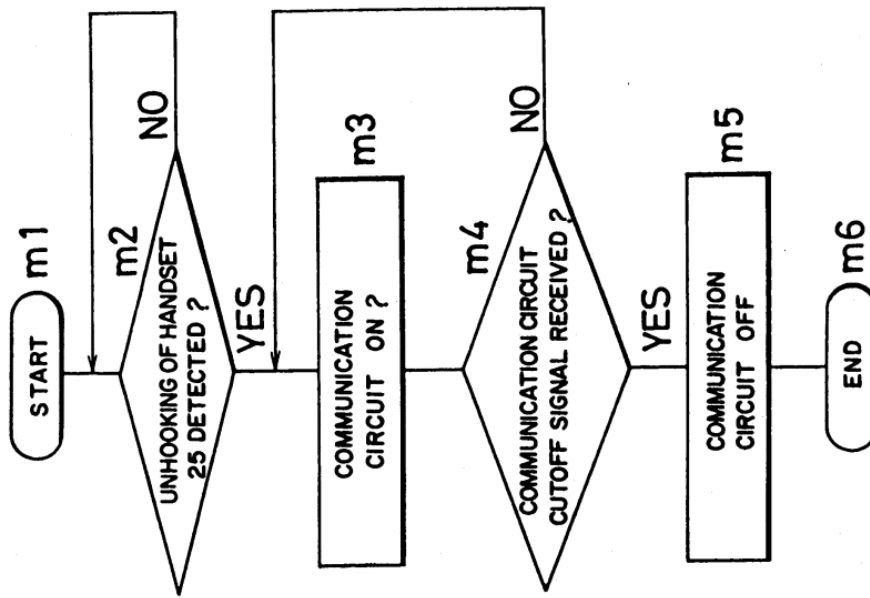

See at Fig. 3.

Fig. 4

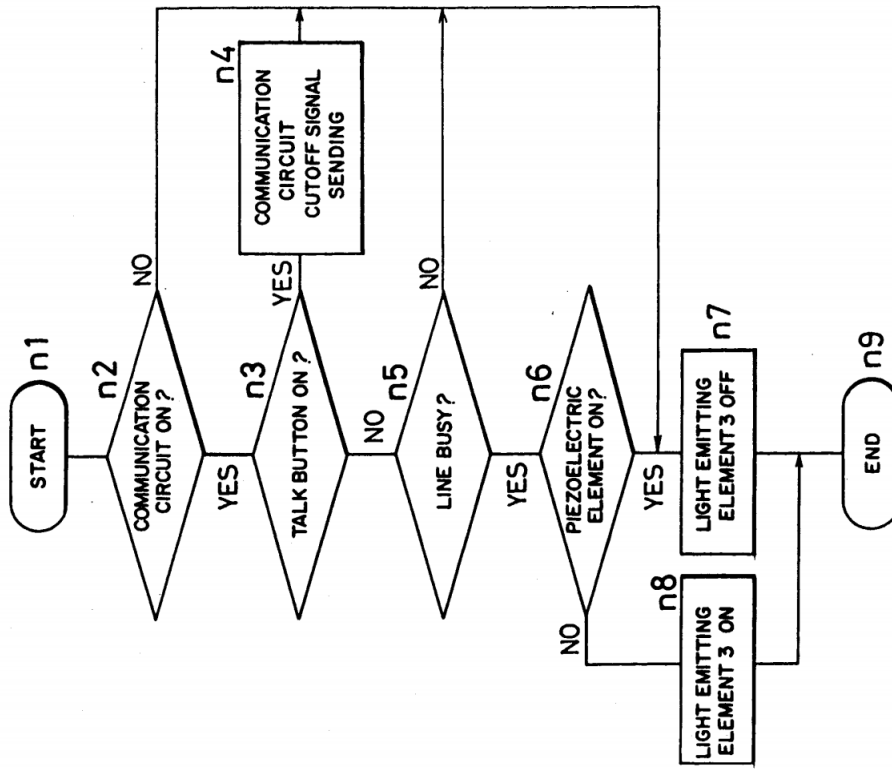

See at Fig. 4.

"1. A cordless telephone apparatus including a base unit connected to a telephone line for communication, and a handset, operatively connected to the base unit by radio

waves, including a speaker, a microphone, a transmitting and receiving circuit for communicating with the base unit by radio waves, transforming the signals from a caller into acoustic sound by the speaker, and second the output from the microphone to the caller, and a battery for providing the transmitting and receiving circuit with electric power, the handset further comprising:

display means for indicating an in-service state of the cordless telephone activated for communication;

contact detecting means for detecting contact of a user with an area proximate to the speaker;

activation detecting means for detecting activation of the cordless telephone for communications to detect the in-service state; and

control means operatively connected to the display means, the contact detecting means and the activation detecting means, for controlling the display means to stop indicating an in-service state when an area proximate to the speaker is detected to be in contact with a user and an in service state is detected, in response to the contact detecting means and activation detecting means, and for controlling the display means to indicate an in-service state when an area proximate to the speaker is not detected to be in contact with a user and an in service state is detected; and

the handset battery means for electrically powering the handset.” Seo at claim 1.

“4. The cordless telephone apparatus of claim 1, wherein the handset further comprises dial means for dial input, and the control means generates a dial signal in response to activation of the dial input means to initiate or call via the base unit.” Seo at claim 4.

“6. A cordless telephone apparatus including a base unit connected to a telephone line and a handset operatively connected to the base unit via radio communication and equipped with a display device for indicating an in-service state of the handset, the handset comprising:

contact detecting means for detecting contact when a part of the body of the user contacts with an area proximate to a speaker of the handset, and

stopping means for stopping the display device from indicating the in-service state when a part of the body of the user is detected to be in contact with an area proximate to the speaker of the handset, in response to the contact detecting means.

7. A handset of a cordless telephone including a base unit and the handset including a speaker and a transmitter for communicating, by radio communications, with the base unit, the handset further comprising:

display means for displaying indication of the cordless telephone being in-service;

detecting means for emitting a signal upon detecting contact of a user to an area of the handset in close proximity to the speaker; and

control means, operatively connected to said display means and said detecting means, for controlling said display means to display indication of the cordless telephone being in-service upon not receiving an output signal from said detecting means when the cordless telephone is in service and for controlling said display means to stop displaying indication of the cordless telephone being in-service upon receiving an output signal from the detecting means when the cordless telephone is in service.

8. The handset of claim 7 further comprising:

in-service detection means, operatively connected to said control means, for outputting a signal to said control means, upon detecting that the cordless telephone is in-service.”
See at claims 6-8.

“14. The handset of claim 7, further comprising:

end of service means, operatively connected to said control means, for outputting a signal to the control means to indicate that the cordless telephone is not in-service, and wherein said control means, upon receipt of said output signal from said end of service

means, controls said display means to stop displaying indication of the cordless telephone being in service.

15. The handset of claim 7, further comprising:

battery means, operatively connected to said display means for providing power to enable said display means to display in-service indication.

16. A method of conserving power of a battery in a cordless telephone, including a handset with a battery, a speaker and a receiver and further including a base unit, which indicates to a user when the cordless telephone is in-service, comprising the steps of:

(a) displaying indication, on the handset, of the cordless telephone in-service;

(b) supplying power from the battery during said step (a) of displaying;

(c) detecting contact of a user to an area of the handset in close proximity to the speaker;

(d) inhibiting said step (a) of displaying by stopping said step (b) of supplying power upon detecting contact in step (c) to thus conserve battery power while said telephone is in-service

17. The method of claim 16, further comprising the step of:

(e) terminating said step (a) of displaying upon said telephone not being in-service. Seo at Claim 17.” Seo at claims 14-17.

To the extent Seo is deemed to not expressly disclose the microprocessor adapted to “determine whether a telephone call is active,” Seo inherently discloses this limitation. Seo specifies that the step of detecting a signal from the proximity sensor (piezoelectric element 7) is reached only after it is determined that the “line is busy”. *See* Seo at 3:62-4:1 (“Further, when the talk button 4 is not pressed at step n3, the operation goes to

step n5. Then when the line is busy, the operation advances to step n6. When the receiver 6 is not in contact with the user's ear, the light emitting element 3 lights up at step n8. In this state, when the user touches the receiver 6 of the handset by the ear, it is detected by the piezoelectric element 7, and the detection signal is sent out to the control circuit 11.”), Fig. 4. A person of ordinary skill in the art at the time of the alleged invention would therefore understand that, in order for the mobile station to determine whether the “line is busy” it must necessarily “determine[s] whether a telephone call is active.” Further as noted above for element [1c] and incorporated by reference here, Seo discloses or renders obvious the use of a microprocessor. Therefore, a person of ordinary skill in the art at the time of the alleged invention would understand that necessarily the microprocessor of Seo would “determine whether a telephone call is active.”

To the extent Seo is deemed to not expressly disclose the microprocessor adapted to “determine whether a telephone call is active,” Seo renders this limitation obvious to one of ordinary skill in the art at the time of the alleged invention. Seo specifies that the step of detecting a signal from the proximity sensor (piezoelectric element 7) is reached only after it is determined that the “line is busy”. *See* Seo at 3:62-4:1 (“Further, when the talk button 4 is not pressed at step n3, the operation goes to step n5. Then when the line is busy, the operation advances to step n6. When the receiver 6 is not in contact with the user's ear, the light emitting element 3 lights up at step n8. In this state, when the user touches the receiver 6 of the handset by the ear, it is detected by the piezoelectric element 7, and the detection signal is sent out to the control circuit 11.”), Fig. 4. Further as noted above for element [1c] and incorporated by reference here, Seo discloses or renders obvious the use of a microprocessor. A person of ordinary skill in the art at the time of the alleged invention would find it obvious to implement the microprocessor of Seo to determine whether the “line is busy.” Doing so would be a design choice driven by a number of different reasons, including that it would support Seo's ability to conserve battery power in mobile stations, and doing so would be within the knowledge and ability of a person of ordinary skill in the art at the

time of the alleged invention. Doing so would also constitute, at least, combining prior art elements according to known methods to yield predictable results, a simple substitution of one known element for another to obtain predictable results, the use of a known technique to improve similar devices in the same way, the application of a known technique to a known device ready for improvement to yield a predictable result, and obvious to try.

To the extent Seo is deemed to not expressly or inherently disclose microprocessor adapted to “determine whether a telephone call is active,” it would be obvious to combine the disclosure of Seo with those of Fukihara 598 as described in the Fukihara 598 claim chart, which is incorporated herein in its entirety by reference. Seo and Fukihara 598 are both directed to conserving battery power in mobile stations generally and more particularly at conserving battery power in mobile stations by using sensors to detect when the user of the mobile station is in a call and unlikely to be looking at the display (as when, for example, the proximity sensor detects the user’s ear by the mobile station) and to power off the display of mobile stations at such times. Seo at 1:36-42 (“It is hence a primary object of the invention to present a novel cordless telephone capable of, by solving the above mentioned technical problems, stopping the display action by the display device while the handset is in service so as to minimize the wasteful consumption of the electric power supplied from the battery or the like.”), 3:64-4:5 (“When the receiver 6 is not in contact with the user’s ear, the light emitting element 3 lights up at step n8. In this state, when the user touches the receiver 6 of the handset by the ear, it is detected by the piezoelectric element 7, and the detection signal is sent out to the control circuit 11. The control circuit 11, on the basis of this detection signal, sends out a stop signal to the driver 12. Thus, driving of the driver 12 is stopped, and the light emitting element 3 is extinguished at step n7.”); Fukiharu 598 at ¶ 0018 (“The present invention, through the use of a structure as described above, enables a reduction in the consumption of battery power, through enabling the lighting devices to be turned OFF when the ear is caused to contact the receiver portion in order to hear the receiver sound during voice communications of a mobile telephone when the lighting devices (backlights) for a liquid crystal display device and keypad portion of a mobile telephone are lit, such as that night.”). A person of ordinary skill in the art at

the time of the alleged invention would be motivated to modify Seo to implement microprocessor adapted to “determine whether a telephone call is active,” as disclosed in Fukihara 598 for a number of different reasons, including that it would support Seo’s ability to conserve battery power in mobile stations, and doing so would be within the knowledge and ability of a person of ordinary skill in the art at the time of the alleged invention. The combination would constitute, at least, combining prior art elements according to known methods to yield predictable results, a simple substitution of one known element for another to obtain predictable results, the use of a known technique to improve similar devices in the same way, the application of a known technique to a known device ready for improvement to yield a predictable result, and obvious to try.

To the extent Seo is deemed to not expressly or inherently disclose the microprocessor adapted to “determine whether a telephone call is active,” it would be obvious to combine the disclosure of Seo with those of Numazawa as described in the Numazawa claim chart, which is incorporated herein in its entirety by reference. Seo and Numazawa are both directed to conserving battery power in mobile stations generally and more particularly at conserving battery power in mobile stations by using sensors to detect when the user of the mobile station is in a call and unlikely to be looking at the display (as when, for example, the proximity sensor detects the user’s ear by the mobile station) and to power off the display of mobile stations at such times. Seo at 1:36-42 (“It is hence a primary object of the invention to present a novel cordless telephone capable of, by solving the above mentioned technical problems, stopping the display action by the display device while the handset is in service so as to minimize the wasteful consumption of the electric power supplied from the battery or the like.”), 3:64-4:5 (“When the receiver 6 is not in contact with the user’s ear, the light emitting element 3 lights up at step n8. In this state, when the user touches the receiver 6 of the handset by the ear, it is detected by the piezoelectric element 7, and the detection signal is sent out to the control circuit 11. The control circuit 11, on the basis of this detection signal, sends out a stop signal to the driver 12. Thus, driving of the driver 12 is stopped, and the light emitting element 3 is extinguished at step n7.”); Numazawa at ¶ Abstract (“To achieve reduced power consumption through stopping operation of unnecessary functions during use of a wireless terminal. A CPU 2 identifies start of a call state

through a signal from a signal processing portion 3 for controlling communication with a base station, and identifies, through an output signal from detecting means 6, whether or not a user ear is in contact with a terminal. Upon identification of contact of the ear to the terminal, controlling means 8 are caused to stop the supply of electric power, from a power supply 7, to displaying means 9 for providing information to a user, and lighting means 10, such as a black light.”, ¶ 0005-0007 (“In the present invention, control is such that, upon determination that the wireless terminal is in a call, operation of functions believe be unnecessary, due to the user of the terminal being in a call, is stopped, and upon termination of the call, operation of the stopped functions is restarted. Additionally, because it is envisioned that there will also be cases where, even during a call, the face of the user may be separated from the receiver of the terminal, control is performed so as to enable restarting of the operations of the functions that had been stopped as unnecessary, through detecting whether or not the user of the terminal has the receiver in contact with an ear. The achievement of reduced power consumption through stopping operation of functions that become unnecessary in use of the terminal, as described above, can be anticipated to have the effect of extending the life of the power supply, such as a battery.”). A person of ordinary skill in the art at the time of the alleged invention would be motivated to modify Seo to implement the microprocessor adapted to “determine whether a telephone call is active,” as disclosed in Numazawa for a number of different reasons, including that it would support Seo’s ability to conserve battery power in mobile stations, and doing so would be within the knowledge and ability of a person of ordinary skill in the art at the time of the alleged invention. The combination would constitute, at least, combining prior art elements according to known methods to yield predictable results, a simple substitution of one known element for another to obtain predictable results, the use of a known technique to improve similar devices in the same way, the application of a known technique to a known device ready for improvement to yield a predictable result, and obvious to try.

To the extent Seo is deemed to not expressly or inherently disclose that “determine whether a telephone call is active,” it would be obvious to combine the disclosure of Seo with those of Miyashita as described in the Miyashita claim chart, which is incorporated herein in its entirety by reference. Seo and Miyashita are both directed to

conserving battery power in mobile stations generally and more particularly at conserving battery power in mobile stations by using sensors to detect when the user of the mobile station is in a call and unlikely to be looking at the display (as when, for example, the proximity sensor detects the user's ear by the mobile station or a sensor detects that the mobile station is in a vertical orientation) and to power off the display of mobile stations at such times. Seo at 1:36-42 ("It is hence a primary object of the invention to present a novel cordless telephone capable of, by solving the above mentioned technical problems, stopping the display action by the display device while the handset is in service so as to minimize the wasteful consumption of the electric power supplied from the battery or the like."), 3:64-4:5 (When the receiver 6 is not in contact with the user's ear, the light emitting element 3 lights up at step n8. In this state, when the user touches the receiver 6 of the handset by the ear, it is detected by the piezoelectric element 7, and the detection signal is sent out to the control circuit 11. The control circuit 11, on the basis of this detection signal, sends out a stop signal to the driver 12. Thus, driving of the driver 12 is stopped, and the light emitting element 3 is extinguished at step n7."); Miyashita at 1:58-63 ("The present invention is directed to solving the problem set forth above. It is therefore an object of the present invention to provide a portable telephone set which can shut off the power supply for a display portion while a content of the display will not be seen during speaking, and thus can reduce power consumption."), 2:6-11 ("In the preferred construction the detector is a gyro. The control apparatus may shut off the power supply for the display when the detector detects the main body at a substantially vertical position. On the other hand, the control may initiate power supply for the display when the detector detects the main body at a substantially horizontal position."). A person of ordinary skill in the art at the time of the alleged invention would be motivated to modify Seo to implement the microprocessor adapted to "determine whether a telephone call is active," as disclosed in Miyashita for a number of different reasons, including that it would support Seo's ability to conserve battery power in mobile stations, and doing so would be within the knowledge and ability of a person of ordinary skill in the art at the time of the alleged invention. The combination would constitute, at least, combining prior art elements according to known methods to yield predictable results, a simple substitution of one known element for another to obtain predictable results, the use of a known technique to improve similar devices in the same way, the application of a known

	<p>technique to a known device ready for improvement to yield a predictable result, and obvious to try.</p>
<p>[1e] (b) receive the signal from the proximity sensor; and</p>	<p>Seo discloses the microprocessor adapted to receive the signal from the proximity sensor.</p> <p>For example: <i>see</i> discussion of claim element [1b], <i>supra</i>, which is incorporated herein by reference.</p> <p>“Still further, the headset includes a device for display to indicate the in-service state, a device for detecting the contact of the speaker area with a part of the body, a device for detecting talking to detect the in-service state, and a device for controlling to stop the display action of the display device when the speaker area is in contact with a part of the body and is in service this stopping of the display device occurs response to the output from the contact detecting device and the talk detecting device. The control device further affects the display action by the display device while the speaker area is not in contact with the body during service. The headset, in this device, is electrically powered by a battery.” Seo at Abstract.</p> <p>“To achieve the above object, the cordless telephone of the invention comprises:</p> <p>(a) a base unit connected to a telephone line so as to communicate by radio waves for talking, and</p> <p>(b) a headset comprising:</p> <p>(b1) a speaker,</p> <p>(b2) a microphone,</p>

(b3) a transmitting and receiving circuit for communicating with the base unit by radio waves, transforming the signals from the caller into acoustic sound in the speaker, and sending the output from the microphone to the caller, and

(b4) a battery for providing the transmitting and receiving circuit with electric power, wherein

(c) the handset further comprises:

(c1) a device for display to indicate the in-service state,

(c2) a device for detecting the contact of the speaker area with a part of the body,

(c3) a device for detecting the talk to detect the in-service state, and

(c4) a device for controlling to stop the display action of the display a device when the speaker area is in contact with a part of the body and is in service, in response to the output from the contact detecting device and talk detecting device, and to effect the display action by the display device while the speaker area is not in contact with the body during service, and

(c5) the handset is electrically powered by the battery.” Seo at 1:43-2:4.

“FIG. 1 is a perspective view showing the entire structure of a cordless telephone 21 according to an embodiment of the invention. The cordless telephone 21 is connected to a telephone line 22, and include a handset 25 and a base unit 23 for radio communication therewith, the base unit 23 having an antenna 24 for radio communication with the handset 25. The handset 25 includes key switches 2 such as numeric keys as a dial input device provided inside the grip of a handset unit 1; a light emitting element 3 as a display device composed of a light emitting diode (LED) or the like disposed in the vicinity of the key switches 2 inside the grip; a disconnect or hang-up button 4 as the talk completion device for changing over between line capturing state and talk waiting state; a transmitter 5 with a microphone 14 built in and located near the mouth of the user; a receiver 6 containing a piezoelectric element 7 known as touch sensor or the like as the contact detecting device when contacting with the ear,

that is, a part of the body of the user contacted while talking; an antenna 8 for communicating with the base unit 23; and a battery 28.” Seo at 3:1-22.”

Fig 1

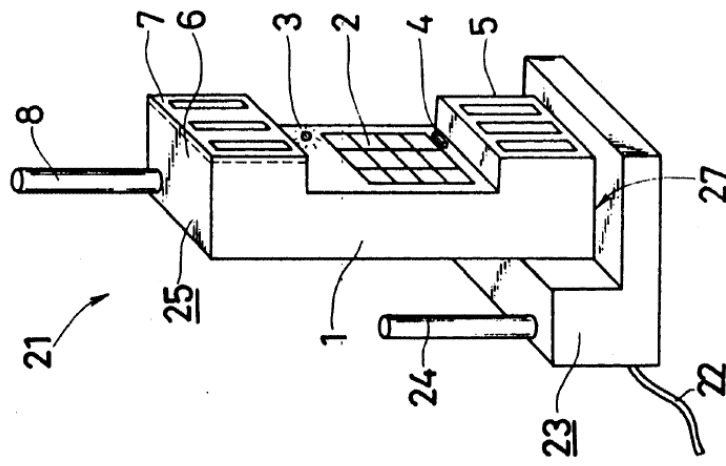

Seo at Fig. 1.

“FIG. 2 is a block diagram showing a schematic electrical construction of the cordless telephone 21.

In this diagram, a key signal by the operation of the key switch 2 is given to a control circuit 11 which is a device for controlling the members in the handset 25. It is also sent out from the antenna 8 through a transmitting and receiving circuit 13, and is received through the antenna 24 of the base unit 23. It is then sent out to the telephone at the destination through the telephone line 22. Further, by the key signal from the key switch 2, the control circuit 11 sends out a drive signal to a driver 12 for lighting up the light emitting element 3. Thus, the driver 12 is driven to light up the light emitting element 3. In the meantime, a signal from the piezoelectric element 7 is applied to the control circuit 11, and a stop signal is sent out to the driver 12 from this piezoelectric element 7. Thus, driving of the driver 12 is stopped to extinguish the light emitting element 3. At the same time, the control circuit 11 sends out a control signal to the transmitting and receiving circuit 13..” See at 3:23-52.

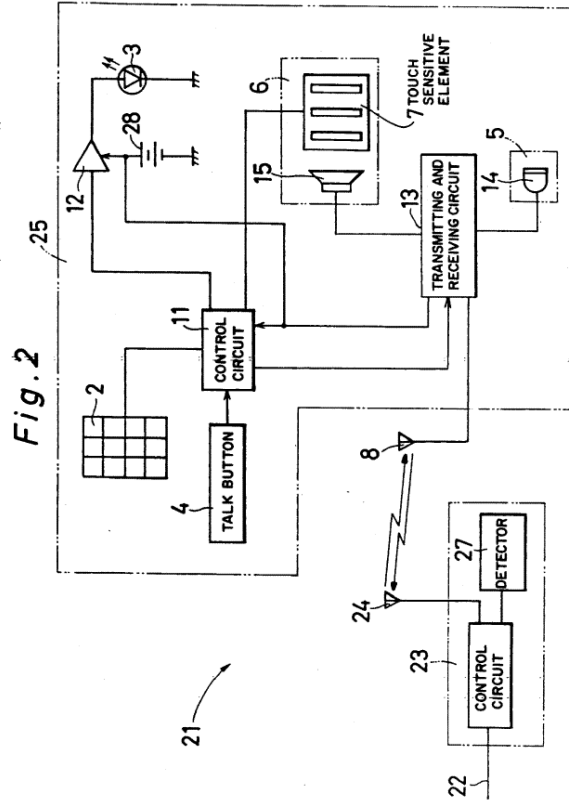

See at Fig. 2.

“At step n1 in FIG. 4, when the key switch 2 is operated and the telephone circuit 22 is connected at step n2, a drive signal is issued from the control circuit 11 to the driver 12. Further, when the talk button 4 is not pressed at step n3, the operation goes to step

n5. Then when the line is busy, the operation advances to step n6. When the receiver 6 is not in contact with the user's ear, the light emitting element 3 lights up at step n8. In this state, when the user touches the receiver 6 of the handset by the ear, it is detected by the piezoelectric element 7, and the detection signal is sent out to the control circuit 11. The control circuit 11, on the basis of this detection signal, sends out a stop signal to the driver 12. Thus, driving of the driver 12 is stopped, and the light emitting element 3 is extinguished at step n7. Afterwards, when the user's ear is departed again from the piezoelectric element 7, the control circuit 11 then sends out a drive signal to the driver 12 to drive the driver 12. This thereby lights the light emitting element 3 again. Afterwards, by pressing the hang-up button 4 at step n3, a communication circuit cut-off signal is sent out from the handset 25 to the base unit 23 at step n4. Thus the base unit 23 receives the communication circuit signal at step m4 in FIG. 3. Then the connection with the telephone line 22 is cut off at step m5, so that the light emitting element 3 of the handset 25 goes out." See at 3:59-4:16.

Fig. 3

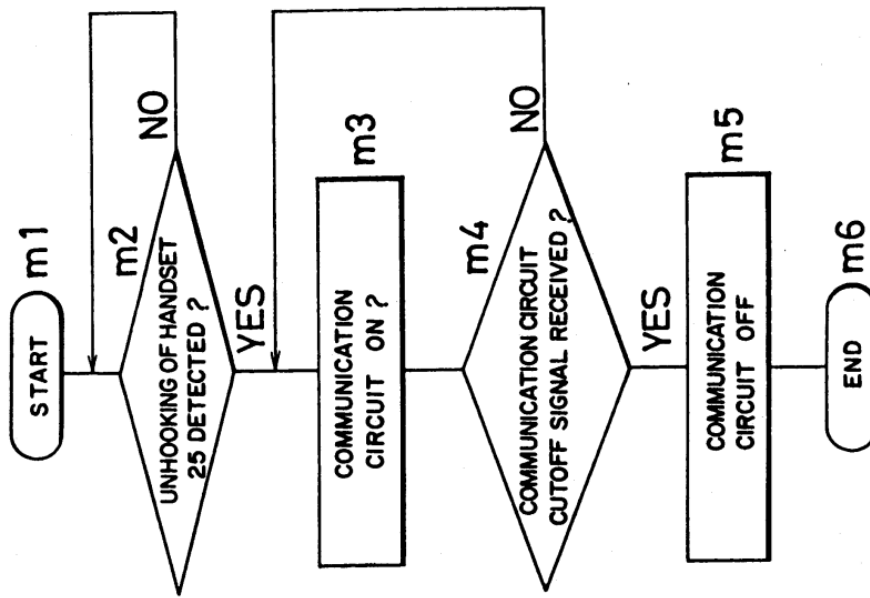

See at Fig. 3.

Fig. 4

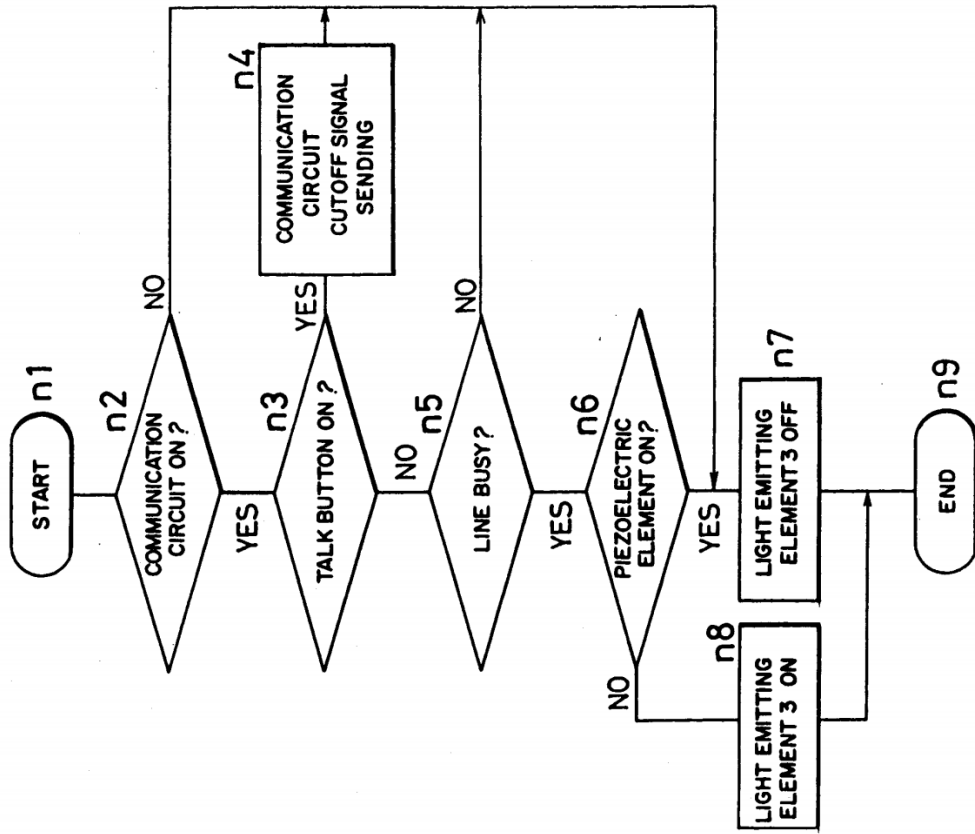

See at Fig. 4.

“1. A cordless telephone apparatus including a base unit connected to a telephone line for communication, and a handset, operatively connected to the base unit by radio waves, including a speaker, a microphone, a transmitting and receiving circuit for communicating with the base unit by radio waves, transforming the signals from a caller into acoustic sound by the speaker, and second the output from the microphone to the caller, and a battery for providing the transmitting and receiving circuit with electric power, the handset further comprising:

display means for indicating an in-service state of the cordless telephone activated for communication;

contact detecting means for detecting contact of a user with an area proximate to the speaker;

activation detecting means for detecting activation of the cordless telephone for communications to detect the in-service state; and

control means operatively connected to the display means, the contact detecting means and the activation detecting means, for controlling the display means to stop indicating an in-service state when an area proximate to the speaker is detected to be in contact with a user and an in service state is detected, in response to the contact detecting means and activation detecting means, and for controlling the display means to indicate an in-service state when an area proximate to the speaker is not detected to be in contact with a user and an in service state is detected; and

the handset battery means for electrically powering the handset.” Seo at claim 1.

“5. The cordless telephone apparatus of claim 1, wherein the contact detecting means includes a penetration hole in an area proximate to the speaker, the speaker being disposed behind the contact detecting means.” Seo at claim 5.

“6. A cordless telephone apparatus including a base unit connected to a telephone line and a handset operatively connected to the base unit via radio communication and

equipped with a display device for indicating an in-service state of the handset, the handset comprising:

contact detecting means for detecting contact when a part of the body of the user contacts with an area proximate to a speaker of the handset, and

stopping means for stopping the display device from indicating the in-service state when a part of the body of the user is detected to be in contact with an area proximate to the speaker of the handset, in response to the contact detecting means.” Seo at claim 6.

“7. A handset of a cordless telephone including a base unit and the handset including a speaker and a transmitter for communicating, by radio communications, with the base unit, the handset further comprising:

display means for displaying indication of the cordless telephone being in-service;

detecting means for emitting a signal upon detecting contact of a user to an area of the handset in close proximity to the speaker; and

control means, operatively connected to said display means and said detecting means, for controlling said display means to display indication of the cordless telephone being in-service upon not receiving an output signal from said detecting means when the cordless telephone is in service and for controlling said display means to stop displaying indication of the cordless telephone being in-service upon receiving an output signal from the detecting means when the cordless telephone is in service.” Seo at claim 7.

“9. The handset of claim 7, wherein the detecting means is a piezoelectric element and the piezoelectric element is disposed in close proximity to the speaker.” Seo at claim 9.

“12. The handset of claim 11, wherein the detecting means is a piezoelectric element disposed in close proximity to the speaker.

	<p>13. The handset of claim 12, wherein the piezoelectric element detects contact of the user's ear to the handset, proximate to the speaker, and outputs a signal.” Seo at claims 12-13.</p> <p>“16. A method of conserving power of a battery in a cordless telephone, including a handset with a battery, a speaker and a receiver and further including a base unit, which indicates to a user when the cordless telephone is in-service, comprising the steps of:</p> <ul style="list-style-type: none"> (a) displaying indication, on the handset, of the cordless telephone in-service; (b) supplying power from the battery during said step (a) of displaying; (c) detecting contact of a user to an area of the handset in close proximity to the speaker; (d) inhibiting said step (a) of displaying by stopping said step (b) of supplying power upon detecting contact in step (c) to thus conserve battery power while said telephone is in-service.” Seo at claim 17. <p>“18. The method of claim 16, wherein said step (c) of detecting contact detects contact of a user's ear to an area of the handset in close proximity to the speaker.” Seo at claim 18.</p>
<p>[1f] (c) reduce power to the display if (i) the microprocessor determines that a telephone call is active and (ii) the signal indicates the proximity of the external object; wherein:</p>	<p>Seo discloses the microprocessor adapted to reduce power to the display if (i) the microprocessor determines that a telephone call is active and (ii) the signal indicates the proximity of the external object.</p> <p>For example: <i>see</i> discussions of claim elements [1b], [1d], [1e], <i>supra</i>, which are incorporated herein by reference.</p> <p>“Still further, the handset includes a device for display to indicate the in-service state, a device for detecting the contact of the speaker area with a part of the body, a device for detecting talking to detect the in-service state, and a device for controlling to stop the</p>

display action of the display device when the speaker area is in contact with a part of the body and is in service this stopping of the display device occurs response to the output from the contact detecting device and the talk detecting device. The control device further affects the display action by the display device while the speaker area is not in contact with the body during service. The handset, in this device, is electrically powered by a battery.” Seo at Abstract.”

“In this case, therefore, the end of a call cannot be confirmed by the handset in the conventional method, and in the hitherto cordless telephone, a pilot lamp is built in the handset as the device for display. This lamp is lit while the handset is in service. Further, by pressing the disconnect or hang up button on the handset after the call is complete, the pilot lamp goes out.” Seo at 1:19-27.

“It is hence a primary object of the invention to present a novel cordless telephone capable of, by solving the above mentioned technical problems, stopping the display action by the display device while the handset is in service so as to minimize the wasteful consumption of the electric power supplied from the battery or the like.” Seo at 1:36-42.

“To achieve the above object, the cordless telephone of the invention comprises:

- (a) a base unit connected to a telephone line so as to communicate by radio waves for talking, and
- (b) a handset comprising:
 - (b1) a speaker,
 - (b2) a microphone,
 - (b3) a transmitting and receiving circuit for communicating with the base unit by radio waves, transforming the signals from the caller into acoustic sound in the speaker, and sending the output from the microphone to the caller, and

(b4) a battery for providing the transmitting and receiving circuit with electric power, wherein

(c) the handset further comprises:

(c1) a device for display to indicate the in-service state,

(c2) a device for detecting the contact of the speaker area with a part of the body,

(c3) a device for detecting the talk to detect the in-service state, and

(c4) a device for controlling to stop the display action of the display a device when the speaker area is in contact with a part of the body and is in service, in response to the output from the contact detecting device and talk detecting device, and to effect the display action by the display device while the speaker area is not in contact with the body during service, and

(c5) the handset is electrically powered by the battery.

Preferably, the display device is a light emitting diode.” Seo at 1:43-2:4.

“The invention also relates to a cordless telephone having a base unit connected to a telephone line and a handset connected to the base unit through radio communication and equipped with a device for display so as to indicate the in-service state by the handset by the display device, which includes:

a device for detecting contact when a part of the body of the user contacts an area proximate to the speaker, and

a device for stopping the display to stop the display action by the display device when a part of the body of the user is in contact with the area proximate to the speaker of the handset, in response to the detection signal from the contact detecting device.

According to invention, when the contact of a part of the body of the user with an area proximate to the speaker of the handset is detected by the contact detecting device, the

display action of the display device is stopped by the display stopping device while a part of the body of the user is in contact with the area proximate to the speaker of the handset. When the part of the body of the user is departed from the area proximate to the speaker of the handset, the display action of the display device is affected again.

Thus, according to the cordless telephone of the invention, while talking, as long as a part of the body of the user remains in contact with the area proximate to the handset, the display action by the display device is not affected to display the in-service state, so that the consumption of the battery while the handset is in service can be minimized.”
See at 2:16-47.

“FIG. 1 is a perspective view showing the entire structure of a cordless telephone 21 according to an embodiment of the invention. The cordless telephone 21 is connected to a telephone line 22, and include a handset 25 and a base unit 23 for radio communication therewith, the base unit 23 having an antenna 24 for radio communication with the handset 25. The handset 25 includes key switches 2 such as numeric keys as a dial input device provided inside the grip of a handset unit 1; a light emitting element 3 as a display device composed of a light emitting diode (LED) or the like disposed in the vicinity of the key switches 2 inside the grip; a disconnect or hang-up button 4 as the talk completion device for changing over between line capturing state and talk waiting state; a transmitter 5 with a microphone 14 built in and located near the mouth of the user; a receiver 6 containing a piezoelectric element 7 known as touch sensor or the like as the contact detecting device when contacting with the ear, that is, a part of the body of the user contacted while talking; an antenna 8 for communicating with the base unit 23; and a battery 28.” See at 3:1-22.”

Fig 1

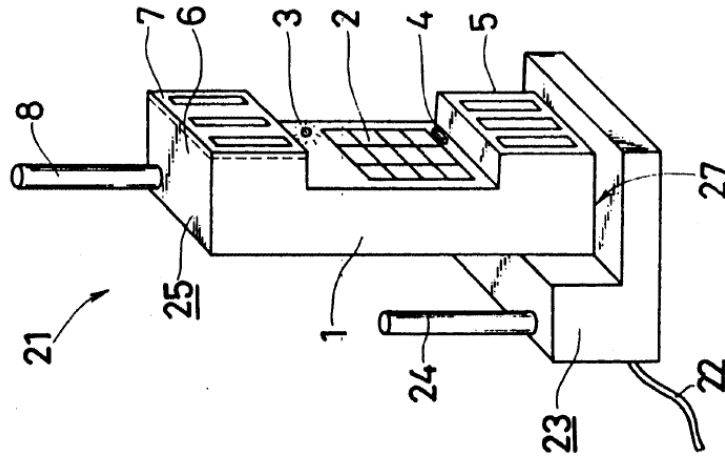

See at Fig. 1.

“FIG. 2 is a block diagram showing a schematic electrical construction of the cordless telephone 21.

In this diagram, a key signal by the operation of the key switch 2 is given to a control circuit 11 which is a device for controlling the members in the handset 25. It is also sent out from the antenna 8 through a transmitting and receiving circuit 13, and is

received through the antenna 24 of the base unit 23. It is then sent out to the telephone at the destination through the telephone line 22. Further, by the key signal from the key switch 2, the control circuit 11 sends out a drive signal to a driver 12 for lighting up the light emitting element 3. Thus, the driver 12 is driven to light up the light emitting element 3. In the meantime, a signal from the piezoelectric element 7 is applied to the control circuit 11, and a stop signal is sent out to the driver 12 from this piezoelectric element 7. Thus, driving of the driver 12 is stopped to extinguish the light emitting element 3. At the same time, the control circuit 11 sends out a control signal to the transmitting and receiving circuit 13. The transmitting and receiving circuit 13 amplifies and modulates the transmission signal received from a microphone 14 built in the transmitter 5. It then sends out a signal from the antenna 8, and demodulates and amplifies the reception signal sent from the antenna 23 through the telephone line 22 which is a communication circuit. Finally, it sends out a signal to a speaker 15 built in the receiver 6. Thus, an acoustic signal is delivered from the speaker 15. Such a handset 25 is electrically powered by a built-in battery 28." Seo at 3:23-52.

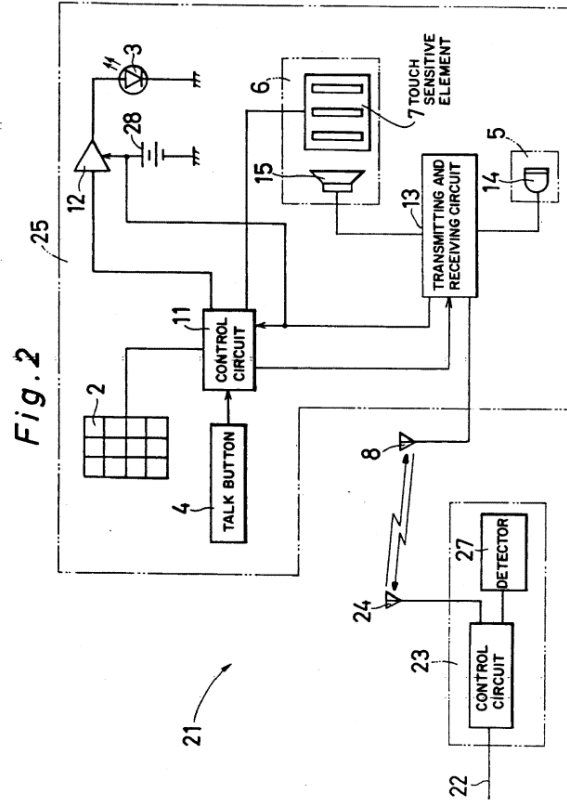

Seo at Fig. 2.

“First, at step m1 in FIG. 3, the talking action is started. The handset 25 is unhooked from the base unit 23 by the caller at step m2. Unhooking is detected by the handset unhook detecting switch 27.

At step n1 in FIG. 4, when the key switch 2 is operated and the telephone circuit 22 is connected at step n2, a drive signal is issued from the control circuit 11 to the driver 12. Further, when the talk button 4 is not pressed at step n3, the operation goes to step n5. Then when the line is busy, the operation advances to step n6. When the receiver 6 is not in contact with the user's ear, the light emitting element 3 lights up at step n8. In this state, when the user touches the receiver 6 of the handset by the ear, it is detected by the piezoelectric element 7, and the detection signal is sent out to the control circuit 11. The control circuit 11, on the basis of this detection signal, sends out a stop signal to the driver 12. Thus, driving of the driver 12 is stopped, and the light emitting element 3 is extinguished at step n7. Afterwards, when the user's ear is departed again from the piezoelectric element 7, the control circuit 11 then sends out a drive signal to the driver 12 to drive the driver 12. This thereby lights the light emitting element 3 again. Afterwards, by pressing the hang-up button 4 at step n3, a communication circuit cut-off signal is sent out from the handset 25 to the base unit 23 at step n4. Thus the base unit 23 receives the communication circuit signal at step m4 in FIG. 3. Then the connection with the telephone line 22 is cut off at step m5, so that the light emitting element 3 of the handset 25 goes out.

In this way, while the handset 25 is in service, the light emitting element 3 is being extinguished, and the consumption of the battery 28 can be considerably reduced.” Seo at 3:55-4:21.

Fig. 3

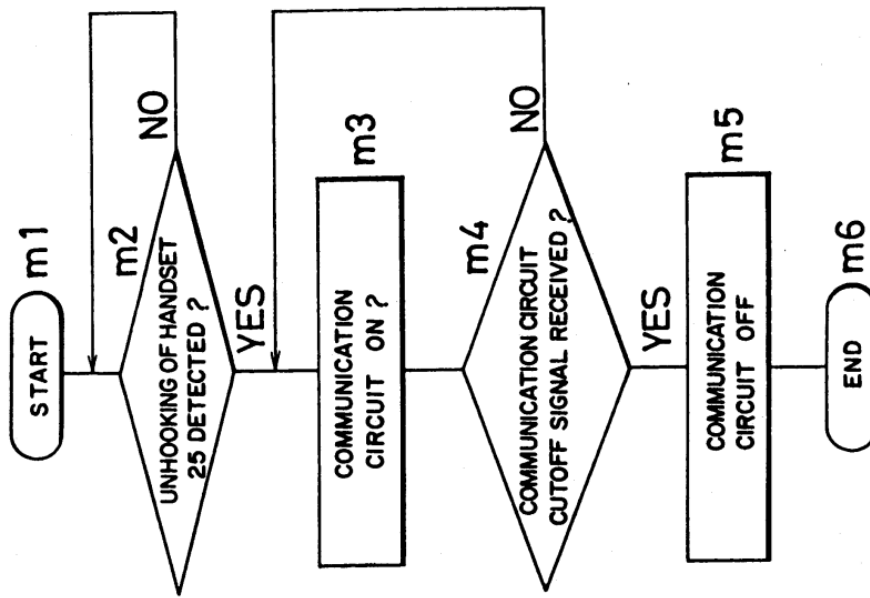

See at Fig. 3.

Fig. 4

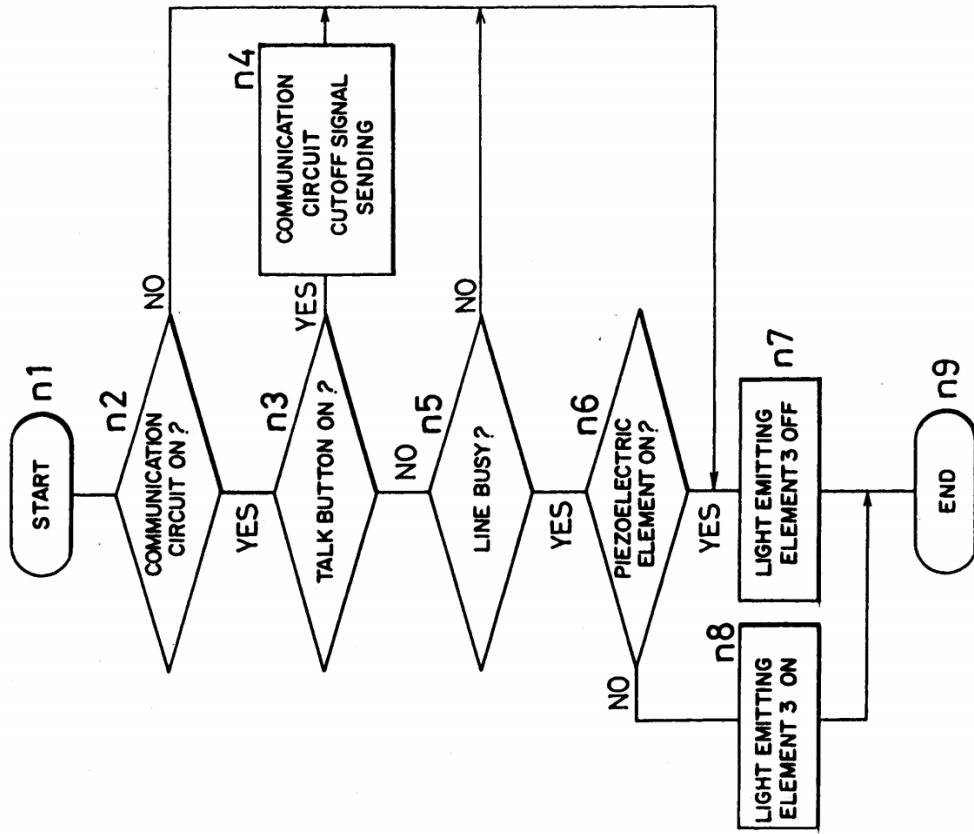

See at Fig. 4.

“1. A cordless telephone apparatus including a base unit connected to a telephone line for communication, and a handset, operatively connected to the base unit by radio waves, including a speaker, a microphone, a transmitting and receiving circuit for communicating with the base unit by radio waves, transforming the signals from a caller into acoustic sound by the speaker, and second the output from the microphone to the caller, and a battery for providing the transmitting and receiving circuit with electric power, the handset further comprising:

display means for indicating an in-service state of the cordless telephone activated for communication;

contact detecting means for detecting contact of a user with an area proximate to the speaker;

activation detecting means for detecting activation of the cordless telephone for communications to detect the in-service state; and

control means operatively connected to the display means, the contact detecting means and the activation detecting means, for controlling the display means to stop indicating an in-service state when an area proximate to the speaker is detected to be in contact with a user and an in service state is detected, in response to the contact detecting means and activation detecting means, and for controlling the display means to indicate an in-service state when an area proximate to the speaker is not detected to be in contact with a user and an in service state is detected; and

the handset battery means for electrically powering the handset.” Seo at claim 1.

“5. The cordless telephone apparatus of claim 1, wherein the contact detecting means includes a penetration hole in an area proximate to the speaker, the speaker being disposed behind the contact detecting means.” Seo at claim 5.

“6. A cordless telephone apparatus including a base unit connected to a telephone line and a handset operatively connected to the base unit via radio communication and

equipped with a display device for indicating an in-service state of the handset, the handset comprising:

contact detecting means for detecting contact when a part of the body of the user contacts with an area proximate to a speaker of the handset, and

stopping means for stopping the display device from indicating the in-service state when a part of the body of the user is detected to be in contact with an area proximate to the speaker of the handset, in response to the contact detecting means.” Seo at claim 6.

“7. A handset of a cordless telephone including a base unit and the handset including a speaker and a transmitter for communicating, by radio communications, with the base unit, the handset further comprising:

display means for displaying indication of the cordless telephone being in-service;

detecting means for emitting a signal upon detecting contact of a user to an area of the handset in close proximity to the speaker; and

control means, operatively connected to said display means and said detecting means, for controlling said display means to display indication of the cordless telephone being in-service upon not receiving an output signal from said detecting means when the cordless telephone is in service and for controlling said display means to stop displaying indication of the cordless telephone being in-service upon receiving an output signal from the detecting means when the cordless telephone is in service.” Seo at claim 7.

“9. The handset of claim 7, wherein the detecting means is a piezoelectric element and the piezoelectric element is disposed in close proximity to the speaker.” Seo at claim 9.

“12. The handset of claim 11, wherein the detecting means is a piezoelectric element disposed in close proximity to the speaker.

	<p>13. The handset of claim 12, wherein the piezoelectric element detects contact of the user's ear to the handset, proximate to the speaker, and outputs a signal.” Seo at claims 12-13.</p> <p>“16. A method of conserving power of a battery in a cordless telephone, including a handset with a battery, a speaker and a receiver and further including a base unit, which indicates to a user when the cordless telephone is in-service, comprising the steps of:</p> <ul style="list-style-type: none"> (a) displaying indication, on the handset, of the cordless telephone in-service; (b) supplying power from the battery during said step (a) of displaying; (c) detecting contact of a user to an area of the handset in close proximity to the speaker; (d) inhibiting said step (a) of displaying by stopping said step (b) of supplying power upon detecting contact in step (c) to thus conserve battery power while said telephone is in-service.” Seo at claim 17. <p>“18. The method of claim 16, wherein said step (c) of detecting contact detects contact of a user's ear to an area of the handset in close proximity to the speaker.” Seo at claim 18.</p>
<p>[1g] the telephone call is a wireless telephone call;</p>	<p>Seo discloses the telephone call as a wireless telephone call.</p> <p>For example: <i>see</i> discussion of claim element 1[d], <i>supra</i>, which is incorporated herein by reference.</p> <p>“CORDLESS TELEPHONE.” Seo at Title.</p>

“A cordless telephone includes a base unit connected to a telephone line so as to communicate by radio waves for talking and a handset. The handset includes a speaker, a microphone, and a transmitting and receiving circuit for communicating with the base unit by radio waves, transforming the signals from the caller into acoustic sound by the speaker, and sending the output from the microphone to the caller. The handset further includes a battery for providing the transmitting and receiving circuit with electric power. Still further, the handset includes a device for display to indicate the in-service state, a device for detecting the contact of the speaker area with a part of the body, a device for detecting talking to detect the in-service state, and a device for controlling to stop the display action of the display device when the speaker area is in contact with a part of the body and is in service this stopping of the display device occurs response to the output from the contact detecting device and the talk detecting device. The control device further affects the display action by the display device while the speaker area is not in contact with the body during service. The handset, in this device, is electrically powered by a battery.” See at Abstract.

To the extent Seo is deemed to not expressly disclose that “the telephone call is a wireless telephone call,” Seo inherently discloses this limitation. For example, as recognized in the 889 patent itself, “[m]obile stations have found many uses in today’s world. When paired with a single base station located at a user’s own premises, they are called ‘cordless telephones.’ When they interact with various, geographically distributed cellular base stations, they are called ‘cellular telephones’ or simply ‘cell phones.’” U.S. Patent No. 7,319,889 (“the ‘889 patent”). A person of ordinary skill in the art at the time of the alleged invention would understand that cordless telephone 21, as described in Seo, is necessarily makes wireless calls and that therefore, necessarily “the telephone call is a wireless telephone call” in Seo.

To the extent Seo is deemed to not expressly or inherently disclose that “the telephone call is a wireless telephone call,” Seo renders this limitation obvious to a person of ordinary skill in the art at the time of the alleged invention.” Seo discloses a “cordless telephone” that “includes a base unit connected to a telephone line so as to

communicate by radio waves....” Seo at Abstract. Furthermore, as recognized in the 889 patent itself, “[m]obile stations have found many uses in today’s world. When paired with a single base station located at a user’s own premises, they are called ‘cordless telephones.’ When they interact with various, geographically distributed cellular base stations, they are called ‘cellular telephones’ or simply ‘cell phones.’”) U.S. Patent No. 7,319,889 (“the ‘889 patent”). Seo also discloses a method of conserving the battery power of the handset of the cordless phone. Seo at 1:36-42 (“It is hence a primary object of the invention to present a novel cordless telephone capable of, by solving the above mentioned technical problems, stopping the display action by the display device while the handset is in service so as to minimize the wasteful consumption of the electric power supplied from the battery or the like.”). It would therefore be obvious to a person of ordinary skill in the art at the time of the alleged invention to use Seo’s methods for conserving battery power for any type of mobile station (whether it be a “cordless telephone” or “cellular telephone”). It would therefore be obvious to a person of ordinary skill in the art at the time of the alleged invention that “the telephone call” in Seo could be a “wireless telephone call.” Such a combination would constitute, at least, combining prior art elements according to known methods to yield predictable results, a simple substitution of one known element for another to obtain predictable results, the use of a known technique to improve similar devices in the same way, the application of a known technique to a known device ready for improvement to yield a predictable result, and obvious to try.

To the extent Seo is deemed to not expressly or inherently disclose that “the telephone call is a wireless telephone call,” it would be obvious to combine the disclosure of Seo with those of Fukihara 598 as described in the Fukihara 598 claim chart, which is incorporated herein in its entirety by reference. Seo and Fukihara 598 are both directed to conserving battery power in mobile stations generally and more particularly at conserving battery power in mobile stations by using sensors to detect when the user of the mobile station is in a call and unlikely to be looking at the display (as when, for example, the proximity sensor detects the user’s ear by the mobile station) and to power off the display of mobile stations at such times. Seo at 1:36-42 (“It is hence a primary object of the invention to present a novel cordless telephone capable of, by

solving the above mentioned technical problems, stopping the display action by the display device while the handset is in service so as to minimize the wasteful consumption of the electric power supplied from the battery or the like.”), 3:64-4:5 (When the receiver 6 is not in contact with the user's ear, the light emitting element 3 lights up at step n8. In this state, when the user touches the receiver 6 of the handset by the ear, it is detected by the piezoelectric element 7, and the detection signal is sent out to the control circuit 11. The control circuit 11, on the basis of this detection signal, sends out a stop signal to the driver 12. Thus, driving of the driver 12 is stopped, and the light emitting element 3 is extinguished at step n7.”); Fukiharu 598 at ¶ 0018 (“The present invention, through the use of a structure as described above, enables a reduction in the consumption of battery power, through enabling the lighting devices to be turned OFF when the ear is caused to contact the receiver portion in order to hear the receiver sound during voice communications of a mobile telephone when the lighting devices (backlights) for a liquid crystal display device and keypad portion of a mobile telephone are lit, such as that night.”). A person of ordinary skill in the art at the time of the alleged invention would be motivated to modify Seo such that “the telephone call is a wireless telephone call,” as disclosed in Fukihara 598 for a number of different reasons, including that it would support Seo’s ability to conserve battery power in mobile stations, and doing so would be within the knowledge and ability of a person of ordinary skill in the art at the time of the alleged invention. The combination would constitute, at least, combining prior art elements according to known methods to yield predictable results, a simple substitution of one known element for another to obtain predictable results, the use of a known technique to improve similar devices in the same way, the application of a known technique to a known device ready for improvement to yield a predictable result, and obvious to try.

To the extent Seo is deemed to not expressly or inherently disclose that “the telephone call is a wireless telephone call,” it would be obvious to combine the disclosure of Seo with those of Numazawa as described in the Numazawa claim chart, which is incorporated herein in its entirety by reference. Seo and Numazawa are both directed to conserving battery power in mobile stations generally and more particularly at conserving battery power in mobile stations by using sensors to detect when the user of

the mobile station is in a call and unlikely to be looking at the display (as when, for example, the proximity sensor detects the user's ear by the mobile station) and to power off the display of mobile stations at such times. Seo at 1:36-42 ("It is hence a primary object of the invention to present a novel cordless telephone capable of, by solving the above mentioned technical problems, stopping the display action by the display device while the handset is in service so as to minimize the wasteful consumption of the electric power supplied from the battery or the like."), 3:64-4:5 (When the receiver 6 is not in contact with the user's ear, the light emitting element 3 lights up at step n8. In this state, when the user touches the receiver 6 of the handset by the ear, it is detected by the piezoelectric element 7, and the detection signal is sent out to the control circuit 11. The control circuit 11, on the basis of this detection signal, sends out a stop signal to the driver 12. Thus, driving of the driver 12 is stopped, and the light emitting element 3 is extinguished at step n7."); Numazawa at ¶ Abstract ("To achieve reduced power consumption through stopping operation of unnecessary functions during use of a wireless terminal. A CPU 2 identifies start of a call state through a signal from a signal processing portion 3 for controlling communication with a base station, and identifies, through an output signal from detecting means 6, whether or not a user ear is in contact with a terminal. Upon identification of contact of the ear to the terminal, controlling means 8 are caused to stop the supply of electric power, from a power supply 7, to displaying means 9 for providing information to a user, and lighting means 10, such as a black light."), ¶ 0005-0007 ("In the present invention, control is such that, upon determination that the wireless terminal is in a call, operation of functions believe be unnecessary, due to the user of the terminal being in a call, is stopped, and upon termination of the call, operation of the stopped functions is restarted. Additionally, because it is envisioned that there will also be cases where, even during a call, the face of the user may be separated from the receiver of the terminal, control is performed so as to enable restarting of the operations of the functions that had been stopped as unnecessary, through detecting whether or not the user of the terminal has the receiver in contact with an ear. The achievement of reduced power consumption through stopping operation of functions that become unnecessary in use of the terminal, as described above, can be anticipated to have the effect of extending the life of the power supply, such as a battery."). A person of ordinary skill in the art at the time of the alleged invention would be motivated to modify Seo such that "the telephone call is a wireless telephone call," as disclosed in Numazawa for a number of

different reasons, including that it would support Seo's ability to conserve battery power in mobile stations, and doing so would be within the knowledge and ability of a person of ordinary skill in the art at the time of the alleged invention. The combination would constitute, at least, combining prior art elements according to known methods to yield predictable results, a simple substitution of one known element for another to obtain predictable results, the use of a known technique to improve similar devices in the same way, the application of a known technique to a known device ready for improvement to yield a predictable result, and obvious to try.

To the extent Seo is deemed to not expressly or inherently disclose that "the telephone call is a wireless telephone call," it would be obvious to combine the disclosure of Seo with those of Miyashita as described in the Miyashita claim chart, which is incorporated herein in its entirety by reference. Seo and Miyashita are both directed to conserving battery power in mobile stations generally and more particularly at conserving battery power in mobile stations by using sensors to detect when the user of the mobile station is in a call and unlikely to be looking at the display (as when, for example, the proximity sensor detects the user's ear by the mobile station or a sensor detects that the mobile station is in a vertical orientation) and to power off the display of mobile stations at such times. Seo at 1:36-42 ("It is hence a primary object of the invention to present a novel cordless telephone capable of, by solving the above mentioned technical problems, stopping the display action by the display device while the handset is in service so as to minimize the wasteful consumption of the electric power supplied from the battery or the like."), 3:64-4:5 (When the receiver 6 is not in contact with the user's ear, the light emitting element 3 lights up at step n8. In this state, when the user touches the receiver 6 of the handset by the ear, it is detected by the piezoelectric element 7, and the detection signal is sent out to the control circuit 11. The control circuit 11, on the basis of this detection signal, sends out a stop signal to the driver 12. Thus, driving of the driver 12 is stopped, and the light emitting element 3 is extinguished at step n7."); Miyashita at 1:58-6:3 ("The present invention is directed to solving the problem set forth above. It is therefore an object of the present invention to provide a portable telephone set which can shut off the power supply for a display portion while a content of the display will not be seen during speaking, and thus can

	<p>reduce power consumption.”), 2:6-11 (“In the preferred construction the detector is a gyro. The control apparatus may shut off the power supply for the display when the detector detects the main body at a substantially vertical position. On the other hand, the control may initiate power supply for the display when the detector detects the main body at a substantially horizontal position.”). A person of ordinary skill in the art at the time of the alleged invention would be motivated to modify Seo such that “the telephone call is a wireless telephone call,” as disclosed in Miyashita for a number of different reasons, including that it would support Seo’s ability to conserve battery power in mobile stations, and doing so would be within the knowledge and ability of a person of ordinary skill in the art at the time of the alleged invention. The combination would constitute, at least, combining prior art elements according to known methods to yield predictable results, a simple substitution of one known element for another to obtain predictable results, the use of a known technique to improve similar devices in the same way, the application of a known technique to a known device ready for improvement to yield a predictable result, and obvious to try.</p>
<p>[1h] the microprocessor reduces power to the display while the signal indicates the proximity of the external object only if the microprocessor determines that the wireless telephone call is active; and</p>	<p>Seo discloses that the microprocessor reduces power to the display while the signal indicates the proximity of the external object only if the microprocessor determines that the wireless telephone call is active.</p> <p>For example: <i>see</i> discussion of claim element [1f], <i>supra</i>, which is incorporated herein by reference.</p> <p>“First, at step m1 in FIG. 3, the talking action is started. The handset 25 is unhooked from the base unit 23 by the caller at step m2. Unhooking is detected by the handset unhook detecting switch 27.</p> <p>At step n1 in FIG. 4, when the key switch 2 is operated and the telephone circuit 22 is connected at step n2, a drive signal is issued from the control circuit 11 to the driver 12. Further, when the talk button 4 is not pressed at step n3, the operation goes to step n5. Then when the line is busy, the operation advances to step n6. When the receiver 6 is not in contact with the user’s ear, the light emitting element 3 lights up at step n8. In this state, when the user touches the receiver 6 of the handset by the ear, it is detected</p>

by the piezoelectric element 7, and the detection signal is sent out to the control circuit 11. The control circuit 11, on the basis of this detection signal, sends out a stop signal to the driver 12. Thus, driving of the driver 12 is stopped, and the light emitting element 3 is extinguished at step n7. Afterwards, when the user's car is departed again from the piezoelectric element 7, the control circuit 11 then sends out a drive signal to the driver 12 to drive the driver 12. This thereby lights the light emitting element 3 again. Afterwards, by pressing the hang-up button 4 at step n3, a communication circuit cut-off signal is sent out from the handset 25 to the base unit 23 at step n4. Thus the base unit 23 receives the communication circuit signal at step m4 in FIG. 3. Then the connection with the telephone line 22 is cut off at step m5, so that the light emitting element 3 of the handset 25 goes out.

In this way, while the handset 25 is in service, the light emitting element 3 is being extinguished, and the consumption of the battery 28 can be considerably reduced." Seo at 3:55-4:21.

Fig. 3

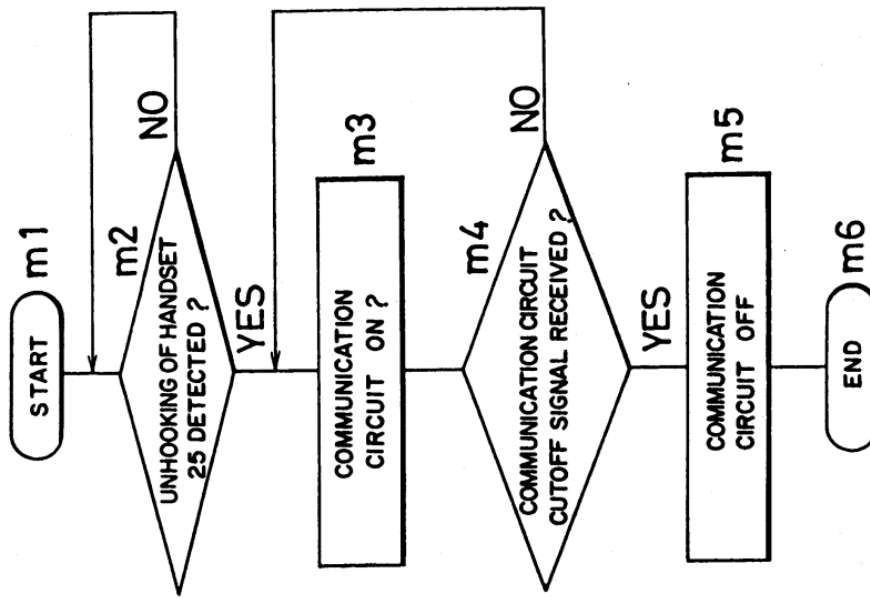

See at Fig. 3.

Fig. 4

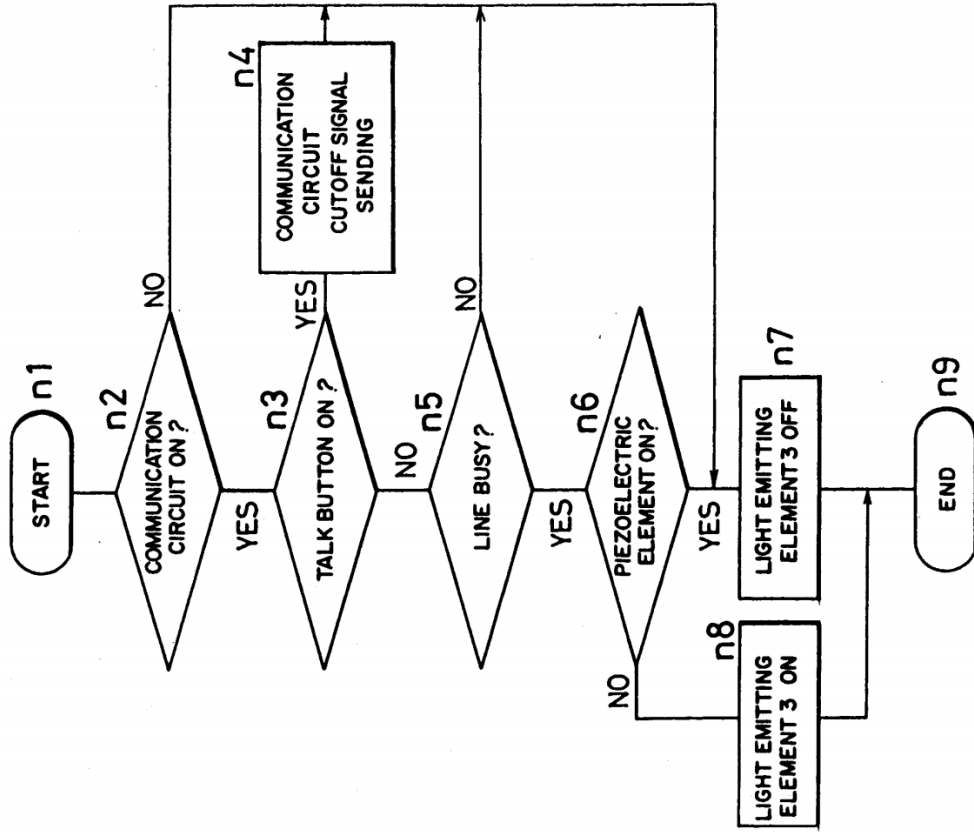

See at Fig. 4.

To the extent Seo is deemed to not expressly disclose that “the microprocessor reduces power to the display while the signal indicates the proximity of the external object only if the microprocessor determines that the wireless telephone call is active,” Seo inherently discloses this limitation. Seo specifies that the step of detecting a signal from the proximity sensor (piezoelectric element 7) is reached only after it is determined that the “line is busy,” and that subsequently the step of the microprocessor (control circuit 11) reducing the power to the display only occurs after the proximity sensor senses the user touching the handset with their ear and sends a detection signal. *See* Seo at 3:62-4:5 (“Further, when the talk button 4 is not pressed at step n3, the operation goes to step n5. Then when the line is busy, the operation advances to step n6. When the receiver 6 is not in contact with the user’s ear, the light emitting element 3 lights up at step n8. In this state, when the user touches the receiver 6 of the handset by the ear, it is detected by the piezoelectric element 7, and the detection signal is sent out to the control circuit 11. The control circuit 11, on the basis of this detection signal, sends out a stop signal to the driver 12. Thus, driving of the driver 12 is stopped, and the light emitting element 3 is extinguished at step n7.”), Fig. 4. Further as noted above for element [1d] and incorporated by reference here, Seo discloses or renders obvious the use of a microprocessor. A person of ordinary skill in the art at the time of the alleged invention would understand that, when a mobile station first determines whether a “line is busy,” then determines whether there is contact with a piezoelectric element and then shuts off power to the display based on a detection signal from the piezoelectric element, necessarily “the microprocessor reduces power to the display while the signal indicates the proximity of the external object only if the microprocessor determines that the wireless telephone call is active.” Therefore, a person of ordinary skill in the art at the time of the alleged invention would understand that in Seo, necessarily “the microprocessor reduces power to the display while the signal indicates the proximity of the external object only if the microprocessor determines that the wireless telephone call is active.”

To the extent Seo is deemed to not expressly disclose that “the microprocessor reduces power to the display while the signal indicates the proximity of the external object only if the microprocessor determines that the wireless telephone call is active,” Seo renders this limitation obvious to one of ordinary skill in the art at the time of the alleged invention. Seo specifies that the step of detecting a signal from the proximity sensor (piezoelectric element 7) is reached only after it is determined that the “line is busy,” and that subsequently the step of the microprocessor (control circuit 11) reducing the power to the display only occurs after the proximity sensor senses the user touching the handset with their ear and sends a detection signal. *See* Seo at 3:62-4:5 (“Further, when the talk button 4 is not pressed at step n3, the operation goes to step n5. Then when the line is busy, the operation advances to step n6. When the receiver 6 is not in contact with the user’s ear, the light emitting element 3 lights up at step n8. In this state, when the user touches the receiver 6 of the handset by the ear, it is detected by the piezoelectric element 7, and the detection signal is sent out to the control circuit 11. The control circuit 11, on the basis of this detection signal, sends out a stop signal to the driver 12. Thus, driving of the driver 12 is stopped, and the light emitting element 3 is extinguished at step n7.”), Fig. 4. Further as noted above for element [1d] and incorporated by reference here, Seo discloses or renders obvious the use of a microprocessor. A person of ordinary skill in the art at the time of the alleged invention would find it obvious to implement the microprocessor of Seo to reduce power to the display only if it determines that the “line is busy” and the piezoelectric element indicates the proximity of an external object. Doing so would be a design choice driven by a number of different reasons, including that it would support Seo’s ability to conserve battery power in mobile stations, and doing so would be within the knowledge and ability of a person of ordinary skill in the art at the time of the alleged invention. Doing so would also constitute, at least, combining prior art elements according to known methods to yield predictable results, a simple substitution of one known element for another to obtain predictable results, the use of a known technique

to improve similar devices in the same way, the application of a known technique to a known device ready for improvement to yield a predictable result, and obvious to try.

To the extent Seo is deemed to not expressly or inherently disclose that “the microprocessor reduces power to the display while the signal indicates the proximity of the external object only if the microprocessor determines that the wireless telephone call is active,” it would be obvious to combine the disclosure of Seo with those of Fukihara 598 as described in the Fukihara 598 claim chart, which is incorporated herein in its entirety by reference. Seo and Fukihara 598 are both directed to conserving battery power in mobile stations generally and more particularly at conserving battery power in mobile stations by using sensors to detect when the user of the mobile station is in a call and unlikely to be looking at the display (as when, for example, the proximity sensor detects the user’s ear by the mobile station) and to power off the display of mobile stations at such times. Seo at 1:36-42 (“It is hence a primary object of the invention to present a novel cordless telephone capable of, by solving the above mentioned technical problems, stopping the display action by the display device while the handset is in service so as to minimize the wasteful consumption of the electric power supplied from the battery or the like.”), 3:64-4:5 (When the receiver 6 is not in contact with the user’s ear, the light emitting element 3 lights up at step n8. In this state, when the user touches the receiver 6 of the handset by the ear, it is detected by the piezoelectric element 7, and the detection signal is sent out to the control circuit 11. The control circuit 11, on the basis of this detection signal, sends out a stop signal to the driver 12. Thus, driving of the driver 12 is stopped, and the light emitting element 3 is extinguished at step n7.”); Fukiharu 598 at ¶ 0018 (“The present invention, through the use of a structure as described above, enables a reduction in the consumption of battery power, through enabling the lighting devices to be turned OFF when the ear is caused to contact the receiver portion in order to hear the receiver sound during voice communications of a mobile telephone when the lighting devices (backlights) for a liquid crystal display device and keypad portion of a mobile telephone are lit, such as that night.”). A person of ordinary skill in the art at the time of the alleged invention would be motivated to modify Seo such that “the microprocessor reduces power to the display while the signal indicates the proximity of the external object only if the

microprocessor determines that the wireless telephone call is active,” as disclosed in Fukihara 598 for a number of different reasons, including that it would support Seo’s ability to conserve battery power in mobile stations, and doing so would be within the knowledge and ability of a person of ordinary skill in the art at the time of the alleged invention. The combination would constitute, at least, combining prior art elements according to known methods to yield predictable results, a simple substitution of one known element for another to obtain predictable results, the use of a known technique to improve similar devices in the same way, the application of a known technique to a known device ready for improvement to yield a predictable result, and obvious to try.

To the extent Seo is deemed to not expressly or inherently disclose the microprocessor adapted to that “the microprocessor reduces power to the display while the signal indicates the proximity of the external object only if the microprocessor determines that the wireless telephone call is active,” it would be obvious to combine the disclosure of Seo with those of Numazawa as described in the Numazawa claim chart, which is incorporated herein in its entirety by reference. Seo and Numazawa are both directed to conserving battery power in mobile stations generally and more particularly at conserving battery power in mobile stations by using sensors to detect when the user of the mobile station is in a call and unlikely to be looking at the display (as when, for example, the proximity sensor detects the user’s ear by the mobile station) and to power off the display of mobile stations at such times. Seo at 1:36-42 (“It is hence a primary object of the invention to present a novel cordless telephone capable of, by solving the above mentioned technical problems, stopping the display action by the display device while the handset is in service so as to minimize the wasteful consumption of the electric power supplied from the battery or the like.”), 3:64-4:5 (When the receiver 6 is not in contact with the user’s ear, the light emitting element 3 lights up at step n8. In this state, when the user touches the receiver 6 of the handset by the ear, it is detected by the piezoelectric element 7, and the detection signal is sent out to the control circuit 11. The control circuit 11, on the basis of this detection signal, sends out a stop signal to the driver 12. Thus, driving of the driver 12 is stopped, and the light emitting element 3 is extinguished at step n7.”); Numazawa at ¶ Abstract (“To achieve reduced power consumption through stopping operation of unnecessary

functions during use of a wireless terminal. A CPU 2 identifies start of a call state through a signal from a signal processing portion 3 for controlling communication with a base station, and identifies, through an output signal from detecting means 6, whether or not a user ear is in contact with a terminal. Upon identification of contact of the ear to the terminal, controlling means 8 are caused to stop the supply of electric power, from a power supply 7, to displaying means 9 for providing information to a user, and lighting means 10, such as a black light.’), ¶ 0005-0007 (“In the present invention, control is such that, upon determination that the wireless terminal is in a call, operation of functions believe be unnecessary, due to the user of the terminal being in a call, is stopped, and upon termination of the call, operation of the stopped functions is restarted. Additionally, because it is envisioned that there will also be cases where, even during a call, the face of the user may be separated from the receiver of the terminal, control is performed so as to enable restarting of the operations of the functions that had been stopped as unnecessary, through detecting whether or not the user of the terminal has the receiver in contact with an ear. The achievement of reduced power consumption through stopping operation of functions that become unnecessary in use of the terminal, as described above, can be anticipated to have the effect of extending the life of the power supply, such as a battery.”). A person of ordinary skill in the art at the time of the alleged invention would be motivated to modify Seo such that “the microprocessor reduces power to the display while the signal indicates the proximity of the external object only if the microprocessor determines that the wireless telephone call is active,” as disclosed in Numazawa for a number of different reasons, including that it would support Seo’s ability to conserve battery power in mobile stations, and doing so would be within the knowledge and ability of a person of ordinary skill in the art at the time of the alleged invention. The combination would constitute, at least, combining prior art elements according to known methods to yield predictable results, a simple substitution of one known element for another to obtain predictable results, the use of a known technique to improve similar devices in the same way, the application of a known technique to a known device ready for improvement to yield a predictable result, and obvious to try.

To the extent Seo is deemed to not expressly or inherently disclose that “the microprocessor reduces power to the display while the signal indicates the proximity of the external object only if the microprocessor determines that the wireless telephone call is active,” it would be obvious to combine the disclosure of Seo with those of Miyashita as described in the Miyashita claim chart, which is incorporated herein in its entirety by reference. Seo and Miyashita are both directed to conserving battery power in mobile stations generally and more particularly at conserving battery power in mobile stations by using sensors to detect when the user of the mobile station is in a call and unlikely to be looking at the display (as when, for example, the proximity sensor detects the user’s ear by the mobile station or a sensor detects that the mobile station is in a vertical orientation) and to power off the display of mobile stations at such times. Seo at 1:36-42 (“It is hence a primary object of the invention to present a novel cordless telephone capable of, by solving the above mentioned technical problems, stopping the display action by the display device while the handset is in service so as to minimize the wasteful consumption of the electric power supplied from the battery or the like.”), 3:64-4:5 (When the receiver 6 is not in contact with the user’s ear, the light emitting element 3 lights up at step n8. In this state, when the user touches the receiver 6 of the handset by the ear, it is detected by the piezoelectric element 7, and the detection signal is sent out to the control circuit 11. The control circuit 11, on the basis of this detection signal, sends out a stop signal to the driver 12. Thus, driving of the driver 12 is stopped, and the light emitting element 3 is extinguished at step n7.”); Miyashita at 1:58-63 (“The present invention is directed to solving the problem set forth above. It is therefore an object of the present invention to provide a portable telephone set which can shut off the power supply for a display portion while a content of the display will not be seen during speaking, and thus can reduce power consumption.”), 2:6-11 (“In the preferred construction the detector is a gyro. The control apparatus may shut off the power supply for the display when the detector detects the main body at a substantially vertical position. On the other hand, the control may initiate power supply for the display when the detector detects the main body at a substantially horizontal position.”). A person of ordinary skill in the art at the time of the alleged invention would be motivated to modify Seo such that “the microprocessor reduces power to the display while the signal indicates the proximity of the external object only if the microprocessor determines that the wireless telephone call is active,” as disclosed in Miyashita for a number of different reasons, including that it would support Seo’s

	<p>ability to conserve battery power in mobile stations, and doing so would be within the knowledge and ability of a person of ordinary skill in the art at the time of the alleged invention. The combination would constitute, at least, combining prior art elements according to known methods to yield predictable results, a simple substitution of one known element for another to obtain predictable results, the use of a known technique to improve similar devices in the same way, the application of a known technique to a known device ready for improvement to yield a predictable result, and obvious to try.</p>
<p>[1i] the proximity sensor begins detecting whether an external object is proximate substantially concurrently with the mobile station initiating an outgoing wireless telephone call or receiving an incoming wireless telephone call.</p>	<p>Seo discloses that the proximity sensor begins to detect whether an external object is proximate substantially concurrently with the mobile station initiating an outgoing wireless telephone call or receiving an incoming wireless telephone call:</p> <p>For example: <i>see</i> discussion of claim elements [1f] and [1h], <i>supra</i>, which are incorporated herein by reference.</p> <p>“First, at step m1 in FIG. 3, the talking action is started. The handset 25 is unhooked from the base unit 23 by the caller at step m2. Unhooking is detected by the handset unhook detecting switch 27.</p> <p>At step n1 in FIG. 4, when the key switch 2 is operated and the telephone circuit 22 is connected at step n2, a drive signal is issued from the control circuit 11 to the driver 12. Further, when the talk button 4 is not pressed at step n3, the operation goes to step n5. Then when the line is busy, the operation advances to step n6. When the receiver 6 is not in contact with the user's ear, the light emitting element 3 lights up at step n8. In this state, when the user touches the receiver 6 of the handset by the ear, it is detected by the piezoelectric element 7, and the detection signal is sent out to the control circuit 11. The control circuit 11, on the basis of this detection signal, sends out a stop signal to the driver 12. Thus, driving of the driver 12 is stopped, and the light emitting element 3 is extinguished at step n7. Afterwards, when the user's ear is departed again from the piezoelectric element 7, the control circuit 11 then sends out a drive signal to</p>

the driver 12 to drive the driver 12. This thereby lights the light emitting element 3 again. Afterwards, by pressing the hang-up button 4 at step n3, a communication circuit cut-off signal is sent out from the handset 25 to the base unit 23 at step n4. Thus the base unit 23 receives the communication circuit signal at step m4 in FIG. 3. Then the connection with the telephone line 22 is cut off at step m5, so that the light emitting element 3 of the handset 25 goes out.

In this way, while the handset 25 is in service, the light emitting element 3 is being extinguished, and the consumption of the battery 28 can be considerably reduced.” Seo at 3:55-4:21.

Fig. 3

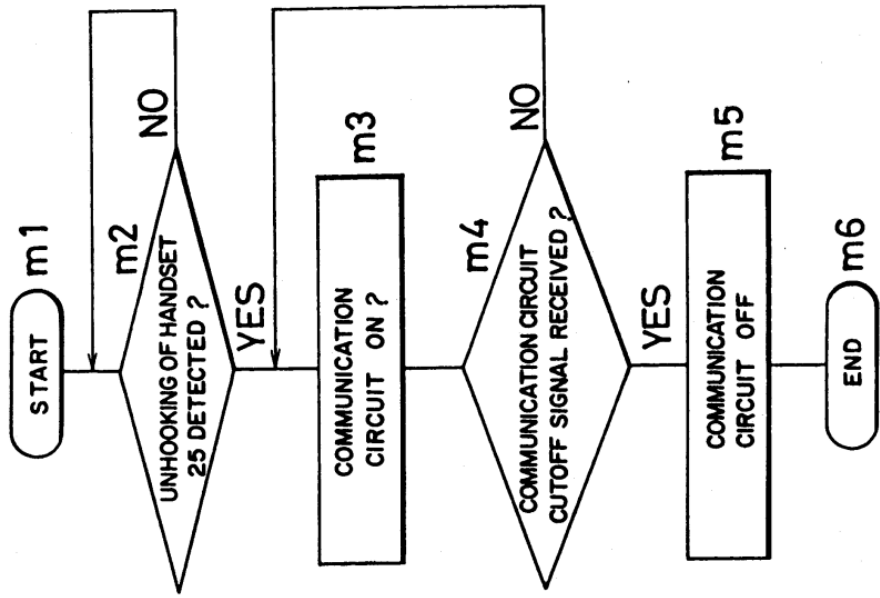

See at Fig. 3.

Fig. 4

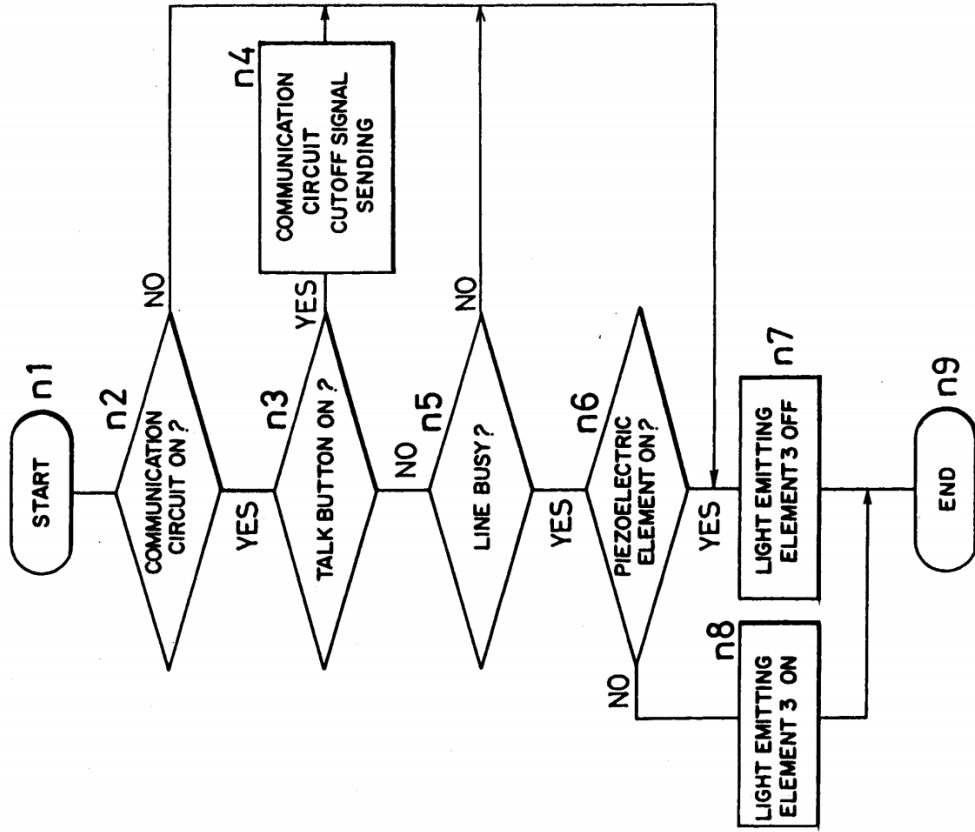

See at Fig. 4.

To the extent Seo is deemed to not expressly disclose “the proximity sensor begins detecting whether an external object is proximate substantially concurrently with the mobile station initiating an outgoing wireless telephone call or receiving an incoming wireless telephone call,” Seo inherently discloses this limitation. In Seo, the microprocessor (control circuit 11) monitors the signal from the proximity sensor (piezoelectric element 7) only after the microprocessor determines that the line is busy. *See* discussion of claim element 1[h], *supra*, incorporate herein by reference. A person of ordinary skill in the art at the time of the alleged invention would understand that “initiating an outgoing wireless telephone call or receiving an incoming wireless telephone call” is how a line becomes busy. Further, a person of ordinary skill in the art would understand that “the proximity sensor begins detecting whether an external object is proximate substantially concurrently with the mobile station initiating an outgoing wireless telephone call or receiving an incoming wireless telephone call” because Seo discloses that this is when the microprocessor monitors the signal from the proximity sensor. Thus, a person of ordinary skill in the art at the time of the alleged invention would understand Seo to inherently disclose that “the proximity sensor begins detecting whether an external object is proximate substantially concurrently with the mobile station initiating an outgoing wireless telephone call or receiving an incoming wireless telephone call.”

To the extent Seo is deemed to not expressly or inherently disclose “the proximity sensor begins detecting whether an external object is proximate substantially concurrently with the mobile station initiating an outgoing wireless telephone call or receiving an incoming wireless telephone call,” Seo renders it obvious to one of skill in the art to have “the proximity sensor begin[] detecting whether an external object is proximate substantially concurrently with the mobile station initiating an outgoing wireless telephone call or receiving an incoming wireless telephone call.” A person of ordinary skill in the art at the time of the alleged invention would understand that “initiating an outgoing wireless telephone call or receiving an incoming wireless telephone call” is how a line becomes busy. Further, it would be obvious to a person of ordinary skill in the art at the time of the alleged invention for “the proximity sensor [to] begin[] detecting whether an external object is proximate substantially concurrently

with the mobile station initiating an outgoing wireless telephone call or receiving an incoming wireless telephone call” because that is the only time when Seo discloses that this is when the microprocessor monitors the signal from the proximity sensor. Because this is the only time that the signal is monitored, it would be obvious to a person of ordinary skill in the art at the time of the alleged invention that the proximity sensor should begin detecting substantially concurrently with the start of this period in order to save additional power.

To the extent Seo is deemed to not expressly or inherently disclose “the proximity sensor begins detecting whether an external object is proximate substantially concurrently with the mobile station initiating an outgoing wireless telephone call or receiving an incoming wireless telephone call,” it would be obvious to combine the disclosure of Seo with those of Fukiharu 598 as described in the Fukiharu 598 claim chart, which is incorporated herein in its entirety by reference. Seo and Fukiharu 598 are both directed to conserving battery power in mobile stations generally and more particularly at conserving battery power in mobile stations by using sensors to detect when the user of the mobile station is in a call and unlikely to be looking at the display (as when, for example, the proximity sensor detects the user’s ear by the mobile station) and to power off the display of mobile stations at such times. Seo at 1:36-42 (“It is hence a primary object of the invention to present a novel cordless telephone capable of, by solving the above mentioned technical problems, stopping the display action by the display device while the handset is in service so as to minimize the wasteful consumption of the electric power supplied from the battery or the like.”), 3:64-4:5 (When the receiver 6 is not in contact with the user’s ear, the light emitting element 3 lights up at step n8. In this state, when the user touches the receiver 6 of the handset by the ear, it is detected by the piezoelectric element 7, and the detection signal is sent out to the control circuit 11. The control circuit 11, on the basis of this detection signal, sends out a stop signal to the driver 12. Thus, driving of the driver 12 is stopped, and the light emitting element 3 is extinguished at step n7.”); Fukiharu 598 at ¶ 0018 (“The present invention, through the use of a structure as described above, enables a reduction in the consumption of battery power, through enabling the lighting devices to be turned OFF when the ear is caused to contact the receiver portion in order to

hear the receiver sound during voice communications of a mobile telephone when the lighting devices (backlights) for a liquid crystal display device and keypad portion of a mobile telephone are lit, such as that night.”). A person of ordinary skill in the art at the time of the alleged invention would be motivated to modify Seo to have “the proximity sensor begin[] detecting whether an external object is proximate substantially concurrently with the mobile station initiating an outgoing wireless telephone call or receiving an incoming wireless telephone call” as disclosed in Fukiharu 598 because the proximity sensor does not need to be detecting when its output is not being monitored, and beginning detecting only during the period when the signal is being monitored would save additional power. The combination would constitute, at least, combining prior art elements according to known methods to yield predictable results, a simple substitution of one known element for another to obtain predictable results, the use of a known technique to improve similar devices in the same way, the application of a known technique to a known device ready for improvement to yield a predictable result, and obvious to try.

To the extent Seo is deemed to not expressly or inherently disclose “the proximity sensor begins detecting whether an external object is proximate substantially concurrently with the mobile station initiating an outgoing wireless telephone call or receiving an incoming wireless telephone call,” it would be obvious to combine the disclosure of Seo with those of Numazawa as described in the Numazawa claim chart, which is incorporated herein in its entirety by reference. Seo and Numazawa are both directed to conserving battery power in mobile stations generally and more particularly at conserving battery power in mobile stations by using sensors to detect when the user of the mobile station is in a call and unlikely to be looking at the display (as when, for example, the proximity sensor detects the user’s ear by the mobile station) and to power off the display of mobile stations at such times. Seo at 1:36-42 (“It is hence a primary object of the invention to present a novel cordless telephone capable of, by solving the above mentioned technical problems, stopping the display action by the display device while the handset is in service so as to minimize the wasteful consumption of the electric power supplied from the battery or the like.”), 3:64-4:5 (When the receiver 6 is not in contact with the user’s ear, the light emitting element 3

lights up at step n8. In this state, when the user touches the receiver 6 of the handset by the ear, it is detected by the piezoelectric element 7, and the detection signal is sent out to the control circuit 11. The control circuit 11, on the basis of this detection signal, sends out a stop signal to the driver 12. Thus, driving of the driver 12 is stopped, and the light emitting element 3 is extinguished at step n7.”); Numazawa at ¶ Abstract (“To achieve reduced power consumption through stopping operation of unnecessary functions during use of a wireless terminal. A CPU 2 identifies start of a call state through a signal from a signal processing portion 3 for controlling communication with a base station, and identifies, through an output signal from detecting means 6, whether or not a user ear is in contact with a terminal. Upon identification of contact of the ear to the terminal, controlling means 8 are caused to stop the supply of electric power, from a power supply 7, to displaying means 9 for providing information to a user, and lighting means 10, such as a black light.”), ¶ 0005-0007 (“In the present invention, control is such that, upon determination that the wireless terminal is in a call, operation of functions believe be unnecessary, due to the user of the terminal being in a call, is stopped, and upon termination of the call, operation of the stopped functions is restarted. Additionally, because it is envisioned that there will also be cases where, even during a call, the face of the user may be separated from the receiver of the terminal, control is performed so as to enable restarting of the operations of the functions that had been stopped as unnecessary, through detecting whether or not the user of the terminal has the receiver in contact with an ear. The achievement of reduced power consumption through stopping operation of functions that become unnecessary in use of the terminal, as described above, can be anticipated to have the effect of extending the life of the power supply, such as a battery.”) A person of ordinary skill in the art at the time of the alleged invention would be motivated to modify Seo to have “the proximity sensor begin[] detecting whether an external object is proximate substantially concurrently with the mobile station initiating an outgoing wireless telephone call or receiving an incoming wireless telephone call” as disclosed in Numazawa because the proximity sensor does not need to be detecting when its output is not being monitored, and beginning detecting only during the period when the signal is being monitored would save additional power. The combination would constitute, at least, combining prior art elements according to known methods to yield predictable results, a simple substitution of one known element for another to obtain predictable results, the use of a known technique to improve similar devices in the same way, the application of a

known technique to a known device ready for improvement to yield a predictable result, and obvious to try.

To the extent Seo is deemed to not expressly or inherently disclose “the proximity sensor begins detecting whether an external object is proximate substantially concurrently with the mobile station initiating an outgoing wireless telephone call or receiving an incoming wireless telephone call,” it would be obvious to combine the disclosure of Seo with those of Miyashita as described in the Miyashita claim chart, which is incorporated herein in its entirety by reference. Seo and Miyashita are both directed to conserving battery power in mobile stations generally and more particularly at conserving battery power in mobile stations by using sensors to detect when the user of the mobile station is in a call and unlikely to be looking at the display (as when, for example, the proximity sensor detects the user’s ear by the mobile station or a sensor detects that the mobile station is in a vertical orientation) and to power off the display of mobile stations at such times. Seo at 1:36-42 (“It is hence a primary object of the invention to present a novel cordless telephone capable of, by solving the above mentioned technical problems, stopping the display action by the display device while the handset is in service so as to minimize the wasteful consumption of the electric power supplied from the battery or the like.”), 3:64-4:5 (When the receiver 6 is not in contact with the user’s ear, the light emitting element 3 lights up at step n8. In this state, when the user touches the receiver 6 of the handset by the ear, it is detected by the piezoelectric element 7, and the detection signal is sent out to the control circuit 11. The control circuit 11, on the basis of this detection signal, sends out a stop signal to the driver 12. Thus, driving of the driver 12 is stopped, and the light emitting element 3 is extinguished at step n7.”); Miyashita at 3:58-4:2 (“In contrast, the display control portion 17 is responsive to the inclination angle information indicative of variation of the inclination angle from the substantially horizontal orientation to the substantially vertical orientation while it performs display control for the display portion 16 to display the control information, to terminate the power supply for the display portion 16. When speaking is performed with the destination person via the speaker 12 and the microphone 14, it is rare to require seeing the display content on the display portion 16. Therefore, the power supply for the display portion 16 is shut down. Thus, exhausting

	<p>of a battery can be reduced.’). While Miyashita discloses a gyro, it would be obvious to one of ordinary skill in the art at the time of the alleged invention to make Seo’s proximity sensor to function in the same way as the gyro in Miyashita as both sensors serve the same function (to serve as an indication that the mobile station’s display is unlikely to be viewed and can therefore be powered off). A person of ordinary skill in the art at the time of the alleged invention would therefore be motivated to modify Seo to have “the proximity sensor begin[] detecting whether an external object is proximate substantially concurrently with the mobile station initiating an outgoing wireless telephone call or receiving an incoming wireless telephone call” as disclosed in Miyashita because the proximity sensor does not need to be detecting when its output is not being monitored, and beginning detecting only during the period when the signal is being monitored would save additional power. The combination would constitute, at least, combining prior art elements according to known methods to yield predictable results, a simple substitution of one known element for another to obtain predictable results, the use of a known technique to improve similar devices in the same way, the application of a known technique to a known device ready for improvement to yield a predictable result, and obvious to try.</p>
<p>[Claim 2] The mobile station of claim 1, wherein the microprocessor reduces power to the display only if (i) the microprocessor determines that a telephone call is active and (ii) the signal indicates the proximity of the external object.</p>	<p>Seo discloses the microprocessor reducing power to the display only if (i) the microprocessor determines that a telephone call is active and (ii) the signal indicates the proximity of the external object.</p> <p>For example: <i>see</i> discussion of claim element [1f], <i>supra</i>, which is incorporated herein by reference.</p>
<p>[Claim 4] The mobile station as recited in claim 1, wherein the microprocessor reduces power to the display by turning off the display.</p>	<p>Seo discloses the microprocessor reducing power to the display by turning off the display.</p>

	<p>For example: <i>see</i> discussion of claim element [1f], <i>supra</i>, which is incorporated herein by reference.</p>
<p>[Claim 5] The mobile station as recited in claim 1, wherein the proximity sensor is a mechanical proximity sensor, an optical sensor, or a range-detecting sensor.</p>	<p>Seo discloses that the proximity sensor is a mechanical proximity sensor, an optical sensor, or a range-detecting sensor.</p> <p>For example: <i>See</i> discussion of claim element [1b], <i>supra</i>, which is incorporated herein by reference.</p> <p>“According to invention, when the contact of a part of the body of the user with an area proximate to the speaker of the handset is detected by the contact detecting device, the display action of the display device is stopped by the display stopping device while a part of the body of the user is in contact with the area proximate to the speaker of the handset. When the part of the body of the user is departed from the area proximate to the speaker of the handset, the display action of the display device is affected again.</p> <p>Thus, according to the cordless telephone of the invention, while talking, as long as a part of the body of the user remains in contact with the area proximate to the handset, the display action by the display device is not affected to display the in-service state, so that the consumption of the battery while the handset is in service can be minimized.” Seo at 2:16-47.</p> <p>“FIG. 1 is a perspective view showing the entire structure of a cordless telephone 21 according to an embodiment of the invention...a receiver 6 containing a piezoelectric element 7 known as touch sensor or the like as the contact detecting device when contacting with the ear, that is, a part of the body of the user contacted while talking;</p>

an antenna 8 for communicating with the base unit 23; and a battery 28.” Seo at 3:1-22.”

Fig 1

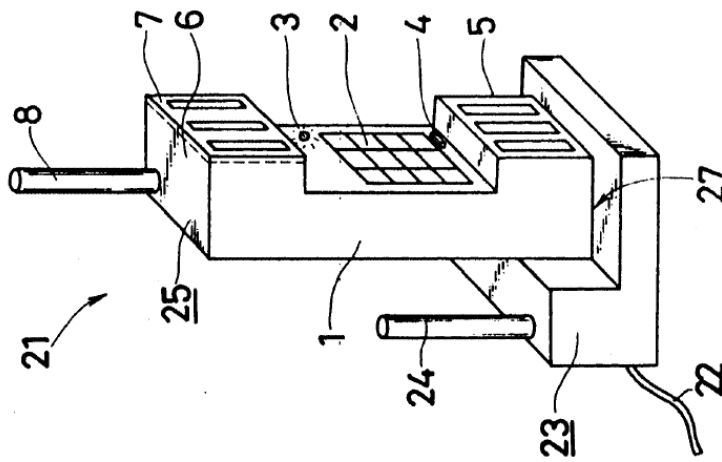

Seo at Fig. 1.

	<p>To the extent Seo is deemed to not expressly disclose “the proximity sensor is a mechanical proximity sensor, an optical sensor, or a range-detecting sensor,” Seo inherently discloses this limitation. In Seo, contact detecting device/piezoelectric element 7 is able to detect contact with a portion of the human body, such as an ear. A person of ordinary skill in the art at the time of the alleged invention would understand that detecting this contact is accomplished by mechanical proximity sensor. Thus, a person of ordinary skill in the art at the time of the alleged invention would understand Seo to inherently disclose “the proximity sensor is a mechanical proximity sensor, an optical sensor, or a range-detecting sensor.”</p> <p>To the extent Seo is deemed to not expressly or inherently disclose “the proximity sensor is a mechanical proximity sensor, an optical sensor, or a range-detecting sensor,” Seo renders it obvious to one of ordinary skill in the art at the time of the alleged invention to use a mechanical proximity sensor. A person of ordinary skill in the art at the time of the alleged invention would be aware of “conventional mechanical proximity (load) sensors,” which the ’889 Patent identifies as known prior art. <i>See</i> ’889 Patent at 3:15-20. A person of ordinary skill in the art at the time of the alleged invention would understand that a mechanical proximity sensor could be used to detect contact with a portion of the human body, such as an ear. Using a mechanical proximity sensor would constitute, at least, combining prior art elements according to known methods to yield predictable results, a simple substitution of one known element for another to obtain predictable results, the use of a known technique to improve similar devices in the same way, the application of a known technique to a known device ready for improvement to yield a predictable result, and obvious to try.</p>

[Claim 6] The mobile station as recited in claim 1, wherein the proximity sensor is located proximate to the display.

Seo discloses that the proximity sensor is located proximate to the display.

For example: *See* discussion of claim element [1b], *supra*, which is incorporated herein by reference.

‘FIG. 1 is a perspective view showing the entire structure of a cordless telephone 21 according to an embodiment of the invention. The cordless telephone 21 is connected to a telephone line 22, and include a handset 25 and a base unit 23 for radio communication therewith, the base unit 23 having an antenna 24 for radio communication with the handset 25. The handset 25 includes key switches 2 such as numeric keys as a dial input device provided inside the grip of a handset unit 1; a light emitting element 3 as a display device composed of a light emitting diode (LED) or the like disposed in the vicinity of the key switches 2 inside the grip; a disconnect or hang-up button 4 as the talk completion device for changing over between line capturing state and talk waiting state; a transmitter 5 with a microphone 14 built in and located near the mouth of the user; a receiver 6 containing a piezoelectric element 7 known as touch sensor or the like as the contact detecting device when contacting with the ear, that is, a part of the body of the user contacted while talking; an antenna 8 for communicating with the base unit 23; and a battery 28.’ Seo at 3:1-22.

Fig 1

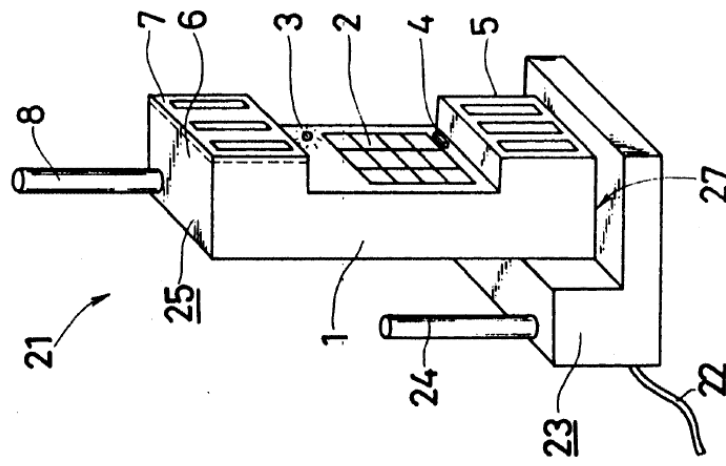

See at Fig. 1.

“ . . . detecting means for emitting a signal upon detecting contact of a user to an area of the handset in close proximity to the speaker; and . . . ” See at Claim 7.

“9. The handset of claim 7, wherein the detecting means is a piezoelectric element and the piezoelectric element is disposed in close proximity to the speaker.” See at Claim 9.

“12. The handset of claim 11, wherein the detecting means is a piezoelectric element disposed in close proximity to the speaker.” See at Claim 12.

“... (c) detecting contact of a user to an area of the handset in close proximity to the speaker; ...” See at Claim 16.

“18. The method of claim 16, wherein said step (c) of detecting contact detects contact of a user's ear to an area of the handset in close proximity to the speaker.” See at Claim 18.

To the extent Seo is deemed to not expressly disclose “the proximity sensor is located proximate to the display,” Seo inherently discloses this limitation. Seo discloses that its invention cuts power to the display during a call when the user has the receiver against his or her ear because the display is an unnecessary function at this time, i.e., it is not visible. A person of ordinary skill in the art at the time of the alleged invention would understand that the display is not visible because the user's head is against it and, if the detecting means is to detect this, it should be “located proximate to the display.” Thus, a person of ordinary skill in the art at the time of the alleged invention would understand Seo to inherently disclose that “the proximity sensor is located proximate to the display.”

To the extent Seo is deemed to not expressly or inherently disclose “the proximity sensor is located proximate to the display,” Seo renders it obvious to one of skill in the art to have “the proximity sensor . . . located proximate to the display.” It would be obvious to a person of ordinary skill in the art at the time of the alleged invention that “the proximity sensor is located proximate to the display” because, in this location, it can determine that the display is not visible because the user’s head is against it. This would constitute, at least, combining prior art elements according to known methods to yield predictable results, a simple substitution of one known element for another to obtain predictable results, the use of a known technique to improve similar devices in the same way, the application of a known technique to a known device ready for improvement to yield a predictable result, and obvious to try.

To the extent Seo is deemed to not expressly or inherently disclose “the proximity sensor is located proximate to the display,” it would be obvious to combine the disclosure of Seo with those of Fukiharu 598 as described in the Fukiharu 598 claim chart, which is incorporated herein in its entirety by reference. Seo and Fukiharu 598 are both directed to conserving battery power in mobile stations generally and more particularly at conserving battery power in mobile stations by using sensors to detect when the user of the mobile station is in a call and unlikely to be looking at the display (as when, for example, the proximity sensor detects the user’s ear by the mobile station) and to power off the display of mobile stations at such times. Seo at 1:36-42 (“It is hence a primary object of the invention to present a novel cordless telephone capable of, by solving the above mentioned technical problems, stopping the display action by the display device while the handset is in service so as to minimize the wasteful consumption of the electric power supplied from the battery or the like.”), 3:64-4:5 (When the receiver 6 is not in contact with the user’s ear, the light emitting element 3 lights up at step n8. In this state, when the user touches the receiver 6 of the handset by the ear, it is detected by the piezoelectric element 7, and the detection signal is sent out to the control circuit 11. The control circuit 11, on the basis of this detection signal, sends out a stop signal to the driver 12. Thus, driving of the driver 12 is stopped, and the light emitting element 3 is extinguished at step n7.”); Fukiharu 598 at ¶ 0018 (“The present invention, through the use of a structure as described above, enables a

reduction in the consumption of battery power, through enabling the lighting devices to be turned OFF when the ear is caused to contact the receiver portion in order to hear the receiver sound during voice communications of a mobile telephone when the lighting devices (backlights) for a liquid crystal display device and keypad portion of a mobile telephone are lit, such as that night.”). A person of ordinary skill in the art at the time of the alleged invention would be motivated to modify Seo to have “the proximity sensor is located proximate to the display” as disclosed in Fukiharu 598 to determine that the display is not visible because the user’s head is against it. The combination would constitute, at least, combining prior art elements according to known methods to yield predictable results, a simple substitution of one known element for another to obtain predictable results, the use of a known technique to improve similar devices in the same way, the application of a known technique to a known device ready for improvement to yield a predictable result, and obvious to try.

To the extent Seo is deemed to not expressly or inherently disclose “the proximity sensor is located proximate to the display,” it would be obvious to combine the disclosure of Seo with those of Numazawa as described in the Numazawa claim chart, which is incorporated herein in its entirety by reference. Seo and Numazawa are both directed to conserving battery power in mobile stations generally and more particularly at conserving battery power in mobile stations by using sensors to detect when the user of the mobile station is in a call and unlikely to be looking at the display (as when, for example, the proximity sensor detects the user’s ear by the mobile station) and to power off the display of mobile stations at such times. Seo at 1:36-42 (“It is hence a primary object of the invention to present a novel cordless telephone capable of, by solving the above mentioned technical problems, stopping the display action by the display device while the handset is in service so as to minimize the wasteful consumption of the electric power supplied from the battery or the like.”), 3:64-4:5 (When the receiver 6 is not in contact with the user’s ear, the light emitting element 3 lights up at step n8. In this state, when the user touches the receiver 6 of the handset by the ear, it is detected by the piezoelectric element 7, and the detection signal is sent out to the control circuit 11. The control circuit 11, on the basis of this detection signal, sends out a stop signal to the driver 12. Thus, driving of the driver 12 is stopped, and

the light emitting element 3 is extinguished at step n7.”); Numazawa at ¶ Abstract (“To achieve reduced power consumption through stopping operation of unnecessary functions during use of a wireless terminal. A CPU 2 identifies start of a call state through a signal from a signal processing portion 3 for controlling communication with a base station, and identifies, through an output signal from detecting means 6, whether or not a user ear is in contact with a terminal. Upon identification of contact of the ear to the terminal, controlling means 8 are caused to stop the supply of electric power, from a power supply 7, to displaying means 9 for providing information to a user, and lighting means 10, such as a black light.”), ¶ 0005-0007 (“In the present invention, control is such that, upon determination that the wireless terminal is in a call, operation of functions believe be unnecessary, due to the user of the terminal being in a call, is stopped, and upon termination of the call, operation of the stopped functions is restarted. Additionally, because it is envisioned that there will also be cases where, even during a call, the face of the user may be separated from the receiver of the terminal, control is performed so as to enable restarting of the operations of the functions that had been stopped as unnecessary, through detecting whether or not the user of the terminal has the receiver in contact with an ear. The achievement of reduced power consumption through stopping operation of functions that become unnecessary in use of the terminal, as described above, can be anticipated to have the effect of extending the life of the power supply, such as a battery.”). A person of ordinary skill in the art at the time of the alleged invention would be motivated to modify Seo to have “the proximity sensor is located proximate to the display” as disclosed in Numazawa to determine that the display is not visible because the user’s head is against it. The combination would constitute, at least, combining prior art elements according to known methods to yield predictable results, a simple substitution of one known element for another to obtain predictable results, the use of a known technique to improve similar devices in the same way, the application of a known technique to a known device ready for improvement to yield a predictable result, and obvious to try.

[Claim 8 – Preamble] 8. A method of conserving battery power in a mobile station, comprising:

To the extent the preamble is construed as limiting, Seo discloses a method of conserving battery power in a mobile station:

For example: *see* discussion of claim 1, *supra*, which is incorporated herein by reference.

“In such a conventional cordless telephone, the pilot lamp is usually located near the call button (input key), and it is not at all visible by the user if the speaker area of the handset is fitted to the ear. Accordingly, it is quite meaningless to always light up the pilot lamp always during call by the handset. This only achieved to the battery is spent purposelessly.” Seo at 1:28-34.

“It is hence a primary object of the invention to present a novel cordless telephone capable of, by solving the above mentioned technical problems, stopping the display action by the display device while the handset is in service so as to minimize the wasteful consumption of the electric power supplied from the battery or the like.” Seo at 1:37-42.

“Thus, according to the cordless telephone of the invention, while talking, as long as a part of the body of the user remains in contact with the area proximate to the handset, the display action by the display device is not affected to display the in-service state, so that the consumption of the battery while the handset is in service can be minimized.”

“In this way, while the handset 25 is in service, the light emitting element 3 is being extinguished, and the consumption of the battery 28 can be considerably reduced.” Seo at 2:41-47.

“16. A method of conserving power of a battery in a cordless telephone, including a handset with a battery, a speaker and a receiver and further including a base unit, which indicates to a user when the cordless telephone is in-service, comprising the steps of:

- (a) displaying indication, on the handset, of the cordless telephone in-service;
- (b) supplying power from the battery during said step (a) of displaying;

(c) detecting contact of a user to an area of the handset in close proximity to the speaker;

(d) inhibiting said step (a) of displaying by stopping said step (b) of supplying power upon detecting contact in step (c) to thus conserve battery power while said telephone is in-service.” Seo at claim 16.

To the extent Seo is deemed to not expressly disclose this claim limitation, Seo inherently discloses this limitation. *See* discussion of claim element [1 preamble], *supra*, which is incorporated herein by reference.

To the extent Seo is deemed to not expressly or inherently disclose this claim limitation, Seo renders it obvious to one of skill in the art at the time of the alleged invention. *See* discussion of claim element [1 preamble], *supra*, which is incorporated herein by reference.

To the extent Seo is deemed to not expressly or inherently disclose this claim element, it would be obvious to combine the disclosure of Seo with those of Numazawa as described in the Numazawa claim chart, which is incorporated herein in its entirety by reference. *See* discussion of claim element [1 preamble], *supra*, which is incorporated herein by reference.

To the extent Seo is deemed to not expressly or inherently disclose this claim element, it would be obvious to combine the disclosure of Seo with those of Fukiharu 598 as described in the Fukiharu 598 claim chart, which is incorporated herein in its entirety by reference. *See* discussion of claim element [1 preamble], *supra*, which is incorporated herein by reference.

To the extent Seo is deemed to not expressly or inherently disclose this claim element, it would be obvious to combine the disclosure of Seo with those of Miyashita as described in the Miyashita claim chart, which is incorporated herein in its entirety by reference. *See* discussion of claim element [1 preamble], *supra*, which is incorporated herein by reference.

<p>[8a] detecting whether an external object is proximate;</p>	<p>Seo discloses detecting whether an external object is proximate.</p> <p>For example: <i>see</i> discussion of claim element [1b], <i>supra</i>, which is incorporated herein by reference.</p> <p>To the extent Seo is deemed to not expressly disclose this claim limitation, Seo inherently discloses this limitation. <i>See</i> discussion of claim element [1b], <i>supra</i>, which is incorporated herein by reference.</p>
<p>[8b] determining whether a telephone call is active; and</p>	<p>Seo discloses determining whether a telephone call is active.</p> <p>For example: <i>see</i> discussion of claim element [1d], <i>supra</i>, which is incorporated herein by reference.</p>
<p>[8c] reducing power consumption of a display of the mobile station if (i) a telephone call is determined to be active and (ii) the proximity of the external object is detected; wherein:</p>	<p>Seo discloses reducing power consumption of a display of the mobile station if (i) a telephone call is determined to be active and (ii) the proximity of the external object is detected.</p> <p>For example: <i>see</i> discussion of claim element [1f], <i>supra</i>, which is incorporated herein by reference.</p>
<p>[8d] the telephone call is a wireless telephone call;</p>	<p>Seo discloses that the telephone call is a wireless telephone call.</p> <p>For example: <i>see</i> discussion of claim element [1g], <i>supra</i>, which is incorporated herein by reference.</p>

	<p>To the extent Seo is deemed to not expressly disclose this claim limitation, Seo inherently discloses this limitation. <i>See</i> discussion of claim element [1g], <i>supra</i>, which is incorporated herein by reference.</p> <p>To the extent Seo is deemed to not expressly or inherently disclose this claim limitation, Seo renders it obvious to one of skill in the art at the time of the alleged invention. <i>See</i> discussion of claim element [1g], <i>supra</i>, which is incorporated herein by reference.</p> <p>To the extent Seo is deemed to not expressly or inherently disclose this claim element, it would be obvious to combine the disclosure of Seo with those of Numazawa as described in the Numazawa claim chart, which is incorporated herein in its entirety by reference. <i>See</i> discussion of claim element [1g], <i>supra</i>, which is incorporated herein by reference.</p> <p>To the extent Seo is deemed to not expressly or inherently disclose this claim element, it would be obvious to combine the disclosure of Seo with those of Fukiharu 598 as described in the Fukiharu 598 claim chart, which is incorporated herein in its entirety by reference. <i>See</i> discussion of claim element [1g], <i>supra</i>, which is incorporated herein by reference.</p> <p>To the extent Seo is deemed to not expressly or inherently disclose this claim element, it would be obvious to combine the disclosure of Seo with those of Miyashita as described in the Miyashita claim chart, which is incorporated herein in its entirety by reference. <i>See</i> discussion of claim element [1g], <i>supra</i>, which is incorporated herein by reference.</p>
<p>[8e] the power consumption of the display is reduced while the proximity of the external object is detected only if the wireless telephone call is determined to be active; and</p>	<p>Seo discloses that the power consumption of the display is reduced while the proximity of the external object is detected only if the wireless telephone call is determined to be active.</p>

For example: *see* discussion of claim element [1h], *supra*, which is incorporated herein by reference.

To the extent Seo is deemed to not expressly disclose this claim limitation, Seo inherently discloses this limitation. *See* discussion of claim element [1h], *supra*, which is incorporated herein by reference.

To the extent Seo is deemed to not expressly or inherently disclose this claim limitation, Seo renders it obvious to one of skill in the art at the time of the alleged invention. *See* discussion of claim element [1h], *supra*, which is incorporated herein by reference.

To the extent Seo is deemed to not expressly or inherently disclose this claim element, it would be obvious to combine the disclosure of Seo with those of Numazawa as described in the Numazawa claim chart, which is incorporated herein in its entirety by reference. *See* discussion of claim element [1h], *supra*, which is incorporated herein by reference.

To the extent Seo is deemed to not expressly or inherently disclose this claim element, it would be obvious to combine the disclosure of Seo with those of Fukiharu 598 as described in the Fukiharu 598 claim chart, which is incorporated herein in its entirety by reference. *See* discussion of claim element [1h], *supra*, which is incorporated herein by reference.

To the extent Seo is deemed to not expressly or inherently disclose this claim element, it would be obvious to combine the disclosure of Seo with those of Miyashita as described in the Miyashita claim chart, which is incorporated herein in its entirety by reference. *See* discussion of claim element [1h], *supra*, which is incorporated herein by reference.

[8f] detecting whether an external object is proximate begins substantially concurrently with the mobile station initiating an outgoing wireless telephone call or receiving an incoming wireless telephone call.

Seo discloses that detecting whether an external object is proximate begins substantially concurrently with the mobile station initiating an outgoing wireless telephone call or receiving an incoming wireless telephone call.

For example: *see* discussion of claim element [1i], *supra*, which is incorporated herein by reference.

To the extent Seo is deemed to not expressly disclose this claim limitation, Seo inherently discloses this limitation. *See* discussion of claim element [1i], *supra*, which is incorporated herein by reference.

To the extent Seo is deemed to not expressly or inherently disclose this claim limitation, Seo renders it obvious to one of skill in the art at the time of the alleged invention. *See* discussion of claim element [1i], *supra*, which is incorporated herein by reference.

To the extent Seo is deemed to not expressly or inherently disclose this claim element, it would be obvious to combine the disclosure of Seo with those of Numazawa as described in the Numazawa claim chart, which is incorporated herein in its entirety by reference. *See* discussion of claim element [1i], *supra*, which is incorporated herein by reference.

To the extent Seo is deemed to not expressly or inherently disclose this claim element, it would be obvious to combine the disclosure of Seo with those of Fukiharu 598 as described in the Fukiharu 598 claim chart, which is incorporated herein in its entirety by reference. *See* discussion of claim element [1i], *supra*, which is incorporated herein by reference.

To the extent Seo is deemed to not expressly or inherently disclose this claim element, it would be obvious to combine the disclosure of Seo with those of Miyashita as described in the Miyashita claim chart, which is incorporated herein in its entirety by reference. *See* discussion of claim element [1i], *supra*, which is incorporated herein by reference.

<p>[Claim 12] The method as recited in claim 8, wherein the detecting of the proximity of the external object is performed by a mechanical proximity sensor, an optical sensor, or a range-detecting sensor.</p>	
	<p>Seo discloses that the detecting of the proximity of the external object is performed by a mechanical proximity sensor, an optical sensor, or a range-detecting sensor.</p> <p>For example: <i>see</i> discussion of claim 5, <i>supra</i>, which is incorporated herein by reference.</p> <p>To the extent Seo is deemed to not expressly disclose this claim limitation, Seo inherently discloses this limitation. <i>See</i> discussion of claim 5, <i>supra</i>, which is incorporated herein by reference.</p> <p>To the extent Seo is deemed to not expressly or inherently disclose this claim limitation, Seo renders it obvious to one of skill in the art at the time of the alleged invention. <i>See</i> discussion of claim 5, <i>supra</i>, which is incorporated herein by reference.</p>

Exhibit A5

**Exhibit #A5 - Perez
to Defendants' Preliminary Invalidity Contentions**

**Invalidity Chart for U.S. Patent No. 7,319,889
U.S. Patent Application Publication No. 2004/0225904A1 ("Perez")**

U.S. Patent Application Publication No. 2004/0225904A1 to Perez ("Perez") was filed on May 6, 2003 and was published on November 11, 2004. Perez is prior art to the '889 Patent under at least pre-AIA 35 U.S.C. § 102(e). Perez anticipates or renders obvious, alone or in combination with other prior art references, each of the Asserted Claims of the '889 Patent as described in the chart below and in the main invalidity contentions document to which this chart is annexed.

It would have been obvious under 35 U.S.C. § 103 to a person having ordinary skill in the art at the time of the alleged invention to combine the teachings of Perez with the following references:

1. Japanese Unexamined Patent Application Publication No. H11-220432 ("Numazawa"). Numazawa qualifies as prior art under at least pre-AIA §§ 102(a), 102(b), and 102(e). Numazawa was published on August 10, 1999.
2. Japanese Unexamined Patent Application Publication No. 2000-106598 to Fukiharu ("Fukiharu 598"). Fukiharu 598 qualifies as prior art under at least pre-AIA §§ 102(a), 102(b), and 102(e). Fukiharu 598 was published on April 11, 2000.
3. U.S. Patent No. 5,586,182 to Miyashita ("Miyashita"). Miyashita qualifies as prior art under at least pre-AIA 35 U.S.C. § 102(e). Miyashita was filed on May 1, 1995 and issued on December 17, 1996.

Asserted Claims	Corresponding Disclosure in the Prior Art Reference(s)
[Claim 1 – Preamble] 1. A mobile station, comprising:	<p>Perez discloses a mobile station.</p> <p>For example:</p> <p>“A portable communication product (10) such as a cellular phone includes a transceiver radio having a microphone (20), an earpiece (22), a keypad (18) and a display (12) coupled to the transceiver radio. The portable communication product further includes at least one sensor (24, 26, 28, or 30) and a processor (16). The sensor can be used for detecting a user condition of the portable communication device such as a talk condition when the user is assumed to be talking on the portable communication product. The processor can be programmed to at least reduce power provided to the display when the sensor detects the talk condition.” Perez at Abstract.</p>

“A method and apparatus for display power management in a portable communication device can provide additional battery savings to enable increased talk times and standby times without altering current battery technology. Embodiments in accordance with the present invention take advantage of actual usage patterns of users of portable phones to reduce current drain by displays and other illumination sources in cellular phones and other portable communication devices.” Perez at [0005].

“In a first aspect of the present invention, a portable communication device comprises a transceiver radio, a display coupled to the transceiver radio, a sensor and a processor. The sensor can be used for detecting a user condition of the portable communication device such as a talk condition when the user is assumed to be talking on the portable communication device. The processor can be programmed to at least reduce power provided to the display when the sensor detects the talk condition. The processor can also turn off power to the display during a talk condition if desired.” Perez at [0006].

“In a second aspect of the present invention, a portable communication device comprises a transceiver radio, a light source coupled to the transceiver radio, an environmental sensor and a processor. The environmental sensor can be used for detecting a user condition of the portable communication device such as a talk condition when the user is assumed to be talking on the portable communication device and the processor can be programmed to at least reduce power provided to the light source when the sensor detects the talk condition.” Perez at [0007].

“In a third aspect of the present invention, a method of power management for a radio communication device having a display comprises the steps of detecting a talking condition and at least reducing the power provided to the display within a predetermined time of the talking condition.” Perez at [0008]

“Referring to FIG. 1, a portable communication product **10** such as a cellular phone includes a transceiver radio having a microphone **20**, an earpiece **22**, a keypad **18** and a display **12** (such as a color display) coupled to the transceiver radio.” Perez at [0013].

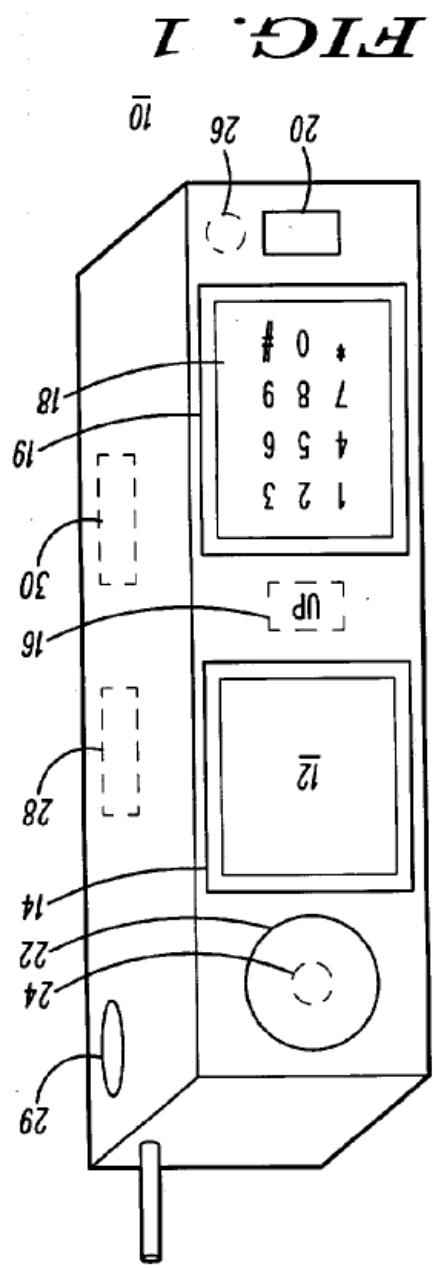

Perez at Fig. 1.

“1. A portable communication device, comprising:
 a transceiver radio;
 a display coupled to the transceiver radio;

	<p>a sensor for detecting a user condition of the portable communication device, wherein the user condition can comprise a talk condition when the user is assumed to be talking on the portable communication device; and</p> <p>a processor programmed to at least reduce power provided to the display when the sensor detects the talk condition.” Perez at Claim 1.</p>
<p>[1a] a display;</p>	<p>Perez discloses a display.</p> <p>For example:</p> <p>“A portable communication product (10) such as a cellular phone includes a transceiver radio having a microphone (20), an earpiece (22), a keypad (18) and a display (12) coupled to the transceiver radio. The portable communication product further includes at least one sensor (24, 26, 28, or 30) and a processor (16). The sensor can be used for detecting a user condition of the portable communication device such as a talk condition when the user is assumed to be talking on the portable communication product. The processor can be programmed to at least reduce power provided to the display when the sensor detects the talk condition.” Perez at Abstract.</p> <p>“A method and apparatus for display power management in a portable communication device can provide additional battery savings to enable increased talk times and standby times without altering current battery technology. Embodiments in accordance with the present invention take advantage of actual usage patterns of users of portable phones to reduce current drain by displays and other illumination sources in cellular phones and other portable communication devices.” Perez at [0005].</p> <p>“In a first aspect of the present invention, a portable communication device comprises a transceiver radio, a display coupled to the transceiver radio, a sensor and a processor. The sensor can be used for detecting a</p>

user condition of the portable communication device such as a talk condition when the user is assumed to be talking on the portable communication device. The processor can be programmed to at least reduce power provided to the display when the sensor detects the talk condition. The processor can also turn off power to the display during a talk condition if desired.” Perez at [0006].

“In a third aspect of the present invention, a method of power management for a radio communication device having a display comprises the steps of detecting a talking condition and at least reducing the power provided to the display within a predetermined time of the talking condition.” Perez at [0008].

“Referring to FIG. 1, a portable communication product **10** such as a cellular phone includes a transceiver radio having a microphone **20**, an earpiece **22**, a keypad **18** and a display **12** (such as a color display) coupled to the transceiver radio.” Perez at [0013].

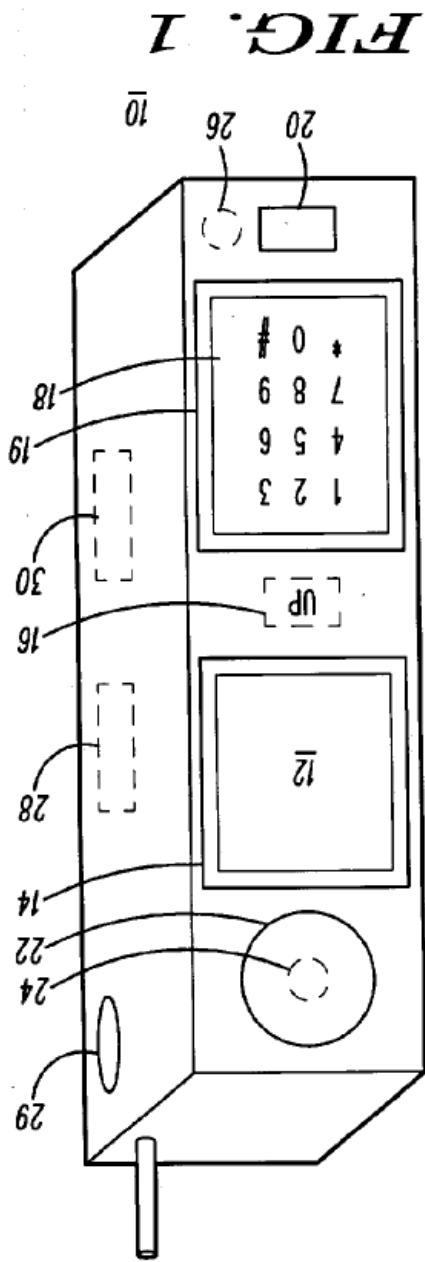

Perez at Fig. 1.

“1. A portable communication device, comprising:

a transceiver radio;

a display coupled to the transceiver radio;

a sensor for detecting a user condition of the portable communication device, wherein the user condition can comprise a talk condition when the user is assumed to be talking on the portable communication device; and

a processor programmed to at least reduce power provided to the display when the sensor detects the talk condition.” Perez at Claim 1.

	<p>“14. The portable communication device of claim 1, wherein the display is a color display.” Perez at Claim 14.</p>
<p>[1b] a proximity sensor adapted to generate a signal indicative of proximity of an external object; and</p>	<p>Perez discloses a proximity sensor adapted to generate a signal indicative of proximity of an external object.</p> <p>For example:</p> <p>“A portable communication product (10) such as a cellular phone includes a transceiver radio having a microphone (20), an earpiece (22), a keypad (18) and a display (12) coupled to the transceiver radio. The portable communication product further includes at least one sensor (24, 26, 28, or 30) and a processor (16). The sensor can be used for detecting a user condition of the portable communication device such as a talk condition when the user is assumed to be talking on the portable communication product. The processor can be programmed to at least reduce power provided to the display when the sensor detects the talk condition.” Perez at Abstract.</p> <p>“Referring to FIG. 1, a portable communication product 10 such as a cellular phone includes a transceiver radio having a microphone 20, an earpiece 22, a keypad 18 and a display 12 (such as a color display) coupled to the transceiver radio. The portable communication product 10 further includes at least one sensor (24, 26, 28 or 30) and a processor 16. The sensor can be used for detecting a user condition of the portable communication device such as a talk condition when the user is assumed to be talking on the portable communication device. The processor 16 can be programmed to at least reduce power provided to the display 12 when the sensor detects the talk condition. The processor 16 can also turn off power to the display 12 during a talk condition if desired.” Perez at [0013].</p>

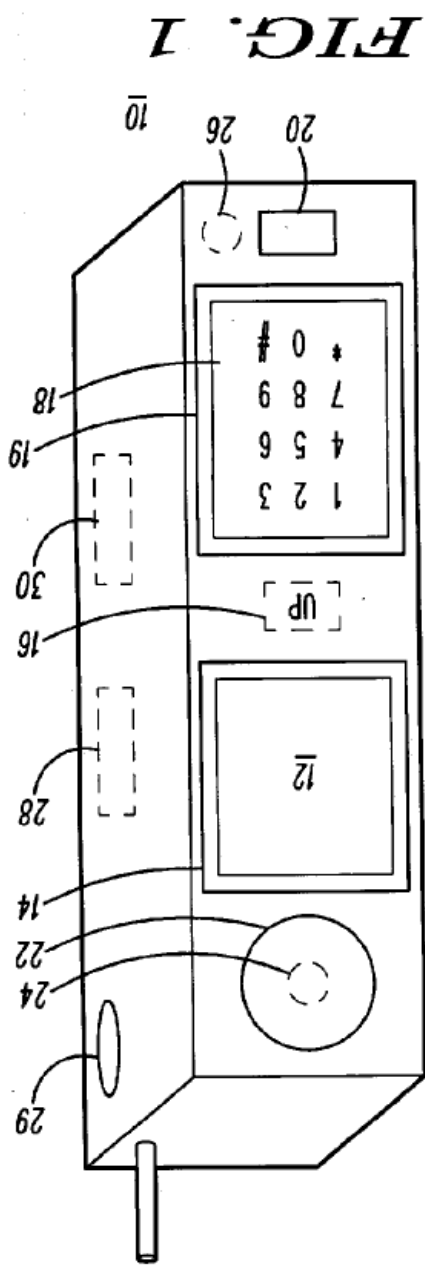

Perez at Fig. 1.

“A talk condition can be sensed in quite a number of ways. After the talk condition is detected or sensed, at least one or more among the display 12, the backlight 14 (for the display), or the backlight 19 (for the keypad) can be turned off or at least operate at a reduced power level. A talk condition, for example, can be sensed by detecting if a predetermined volume of acoustic sound is being received at the microphone 20 or at another sensor such as a proximity sensor 26 indicative of a user talking on the portable communication device. The sensors 20 or 26 can detect if a predetermined volume of acoustic sound is being received at either sensor. Alternatively, a talk condition can be sensed by measuring at least one among a spectrum density or a spectrum energy of a bounced signal to determine the proximity of a user's head to an earpiece of the portable communication device using a microphone or a proximity sensor 24 as further detailed with respect to FIG. 3. A talk condition can also be sensed by detecting an angle at which the portable communication device 10 is positioned or by detecting a vibration of the portable communication device 10. There is no need to keep the display 12 on if the phone is sitting idle. Ergonomically, a phone will be used at a certain predetermined angle-range anytime a phone call is active and the user is listening to the earpiece. A sensor 28 for sensing either the angle or a vibration of the portable communication device can be embodied

by a microelectronic mechanical systems (MEMS) device. Another way for sensing a talk condition can be achieved by sensing if the portable communication device 10 is in a user's hand. A sensor 30 can be a differential pressure sensor or a thermal sensor that indicates that the phone is in a user's hands. All the sensors described above should be considered environmental sensors with respect to the present invention.” Perez at [0015].

“In one particular embodiment as shown in FIG. 3, the sensor or sensors 100 can comprise the earpiece 22, the microphone 24, a coder/decoder 104 and a digital signal processor (DSP) 102. The sensor 100 can utilize an acoustic feedback algorithm that measures at least a spectrum density or a spectrum energy of a bounced signal to determine the proximity of a user's head to the earpiece 22 of the portable communication device. The sensor 100 can also be used to control the outbound audio quality or provide a constant audio level (from the perspective of the user) by automatically adjusting the audio level based on the proximity to the ear of the user. This automatic adjustment can additionally lower the power consumption by the audio coder/decoder 104.” Perez at [0019].

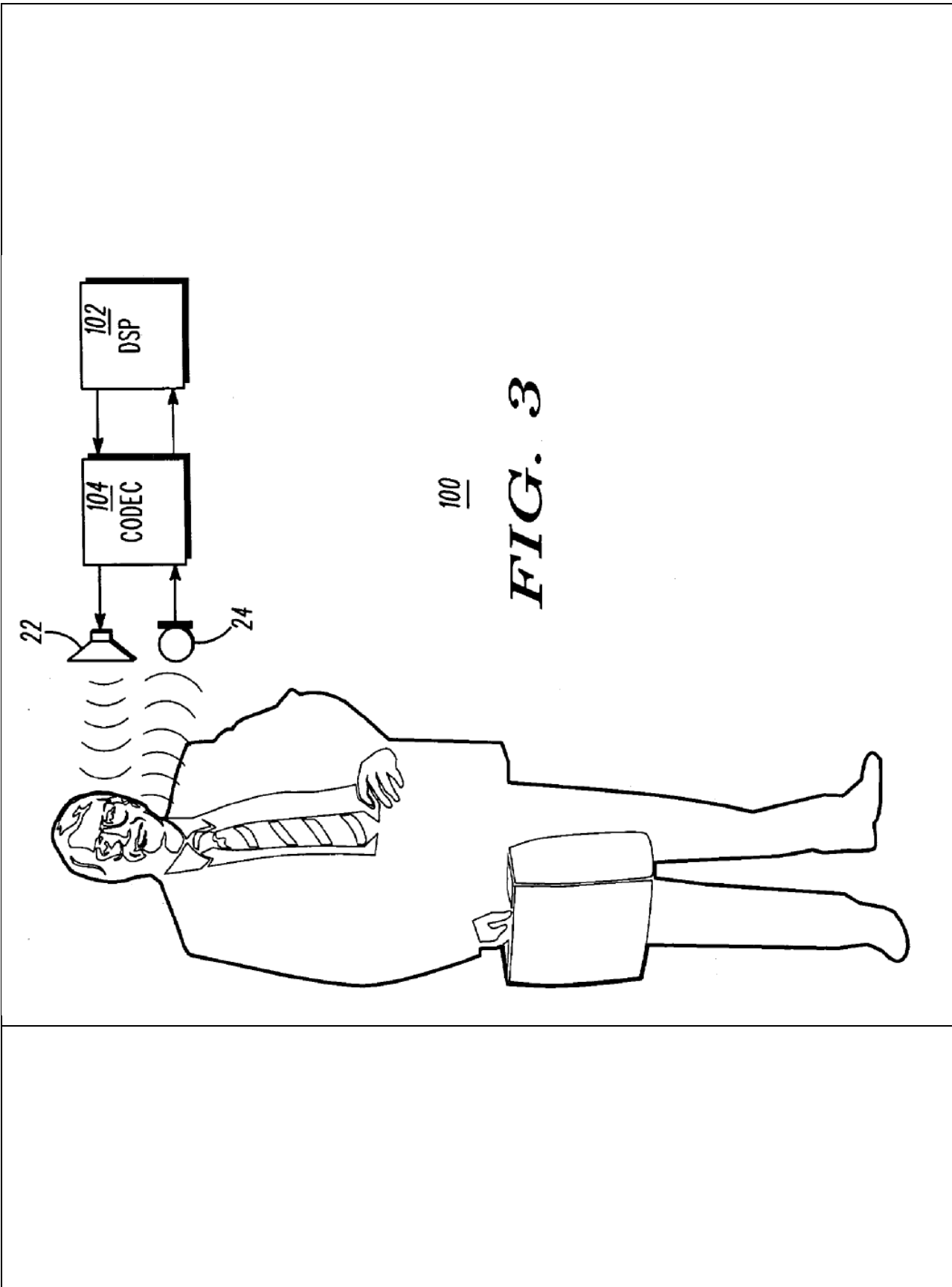

100
FIG. 3

	<p>Perez at Fig. 3.</p> <p>“5. The portable communication device of claim 1, wherein the sensor comprises a proximity sensor for detecting if a predetermined volume of acoustic sound is being received at a microphone indicative of a user talking on the portable communication device.” Perez at Claim 5.</p> <p>“6. The portable communication device of claim 1, wherein the sensor comprises an acoustic feedback algorithm that measures at least one among a spectrum density and a spectrum energy of a bounced signal to determine the proximity of a user's head to an earpiece of the portable communication device.” Perez at Claim 6.</p>
<p>[1c] a microprocessor adapted to:</p>	<p>Perez discloses a microprocessor.</p> <p>For example:</p> <p>“A portable communication product (10) such as a cellular phone includes a transceiver radio having a microphone (20), an earpiece (22), a keypad (18) and a display (12) coupled to the transceiver radio. The portable communication product further includes at least one sensor (24, 26, 28, or 30) and a processor (16). The sensor can be used for detecting a user condition of the portable communication device such as a talk condition when the user is assumed to be talking on the portable communication product. The processor can be programmed to at least reduce power provided to the display when the sensor detects the talk condition.” Perez at Abstract.</p> <p>“In a first aspect of the present invention, a portable communication device comprises a transceiver radio, a display coupled to the transceiver radio, a sensor and a processor. The sensor can be used for detecting a user condition of the portable communication device such as a talk condition when the user is assumed to be talking on the portable communication device. The processor can be programmed to at least reduce</p>

power provided to the display when the sensor detects the talk condition. The processor can also turn off power to the display during a talk condition if desired.” Perez at [0006].

“In a second aspect of the present invention, a portable communication device comprises a transceiver radio, a light source coupled to the transceiver radio, an environmental sensor and a processor. The environmental sensor can be used for detecting a user condition of the portable communication device such as a talk condition when the user is assumed to be talking on the portable communication device and the processor can be programmed to at least reduce power provided to the light source when the sensor detects the talk condition.” Perez at [0007].

“Referring to FIG. 1, a portable communication product **10** such as a cellular phone includes a transceiver radio having a microphone **20**, an earpiece **22**, a keypad **18** and a display **12** (such as a color display) coupled to the transceiver radio. The portable communication product **10** further includes at least one sensor (**24**, **26**, **28** or **30**) and a processor **16**. The sensor can be used for detecting a user condition of the portable communication device such as a talk condition when the user is assumed to be talking on the portable communication device. The processor **16** can be programmed to at least reduce power provided to the display **12** when the sensor detects the talk condition. The processor **16** can also turn off power to the display **12** during a talk condition if desired.” Perez at [0013].

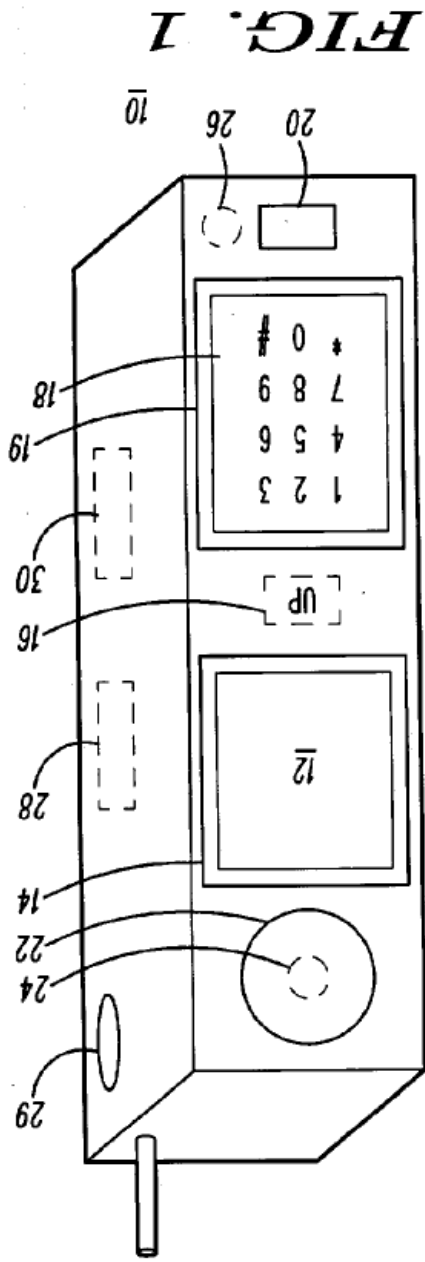

Perez at Fig. 1.

“In light of the foregoing description of the invention, it should be recognized that the present invention can be realized in hardware, software, or a combination of hardware and software. A method and system for power management in a communication device according to the present invention can be realized in a centralized fashion in one computer system or processor, or in a distributed fashion where different elements are spread across several interconnected computer systems or processors (such as a microprocessor and a DSP). Any kind of computer system, or other apparatus adapted for carrying out the methods described herein, is suited. A typical combination of hardware and software could be a general purpose computer system with a computer program that, when being loaded and executed, controls the computer system such that it carries out the methods described herein.” Perez at [0023].

“1. A portable communication device, comprising:

	<p>a transceiver radio; a display coupled to the transceiver radio; a sensor for detecting a user condition of the portable communication device, wherein the user condition can comprise a talk condition when the user is assumed to be talking on the portable communication device; and a processor programmed to at least reduce power provided to the display when the sensor detects the talk condition.” Perez at Claim 1.</p>
<p>[1d] (a) determine whether a telephone call is active;</p>	<p>Perez discloses the microprocessor adapted to determine whether a telephone call is active.</p> <p>For example:</p> <p>“A portable communication product (10) such as a cellular phone includes a transceiver radio having a microphone (20), an earpiece (22), a keypad (18) and a display (12) coupled to the transceiver radio. The portable communication product further includes at least one sensor (24, 26, 28, or 30) and a processor (16). The sensor can be used for detecting a user condition of the portable communication device such as a talk condition when the user is assumed to be talking on the portable communication product. The processor can be programmed to at least reduce power provided to the display when the sensor detects the talk condition.” Perez at Abstract.</p> <p>“In a first aspect of the present invention, a portable communication device comprises a transceiver radio, a display coupled to the transceiver radio, a sensor and a processor. The sensor can be used for detecting a user condition of the portable communication device such as a talk condition when the user is assumed to be talking on the portable communication device. The processor can be programmed to at least reduce</p>

power provided to the display when the sensor detects the talk condition. The processor can also turn off power to the display during a talk condition if desired.” Perez at [0006].

“In a second aspect of the present invention, a portable communication device comprises a transceiver radio, a light source coupled to the transceiver radio, an environmental sensor and a processor. The environmental sensor can be used for detecting a user condition of the portable communication device such as a talk condition when the user is assumed to be talking on the portable communication device and the processor can be programmed to at least reduce power provided to the light source when the sensor detects the talk condition.” Perez at [0007].

“In a third aspect of the present invention, a method of power management for a radio communication device having a display comprises the steps of detecting a talking condition and at least reducing the power provided to the display within a predetermined time of the talking condition.” Perez at [0008]

“The step of detecting a talk condition can be selected from the group of conditions consisting of a) detecting if a predetermined volume of acoustic sound is being received at a microphone indicative of a user talking on the portable communication device; b) measuring at least one among a spectrum density and a spectrum energy of a bounced signal to determine the proximity of a user's head to an earpiece of the portable communication device; c) measuring a predetermined period after a phone call starts; d) detecting an angle at which the portable communication device is positioned; e) detecting a vibration of the portable communication device; and f) detecting if the portable communication device is in a user's hand.” Perez at [0009].

“Referring to FIG. 1, a portable communication product **10** such as a cellular phone includes a transceiver radio having a microphone **20**, an earpiece **22**, a keypad **18** and a display **12** (such as a color display) coupled to the transceiver radio. The portable communication product **10** further includes at least one sensor (**24**, **26**, **28** or **30**) and a processor **16**. The sensor can be used for detecting a user condition of the portable

communication device such as a talk condition when the user is assumed to be talking on the portable communication device. The processor 16 can be programmed to at least reduce power provided to the display 12 when the sensor detects the talk condition. The processor 16 can also turn off power to the display 12 during a talk condition if desired.” Perez at [0013].

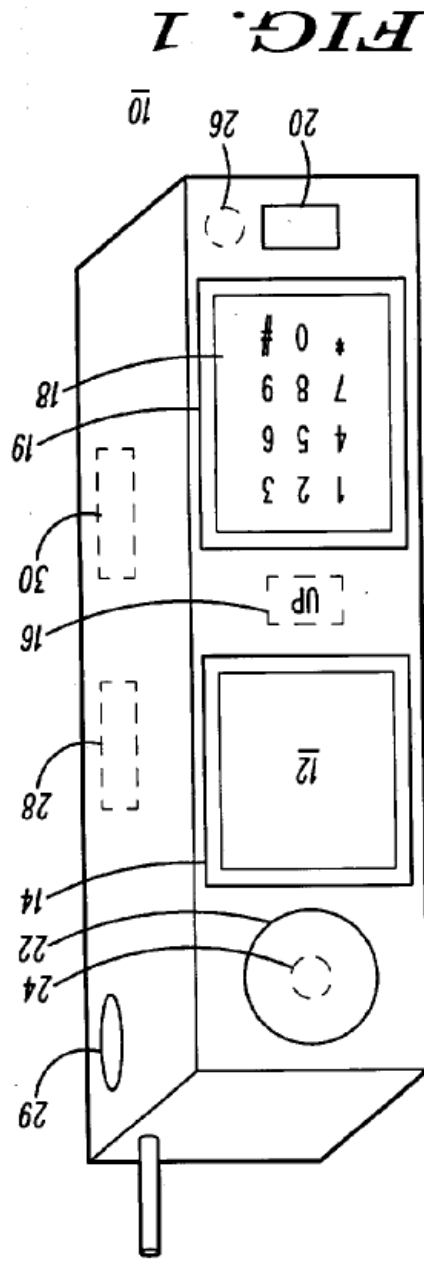

Perez at Fig. 1.

“In one embodiment, the portable communication device 10 can also include other illumination or lighting devices. For example, the display 12 can have backlighting 14 and/or the keypads can have backlighting 19 as is well known in the industry. Although backlighting provides great ergonomic benefits to a user in visually reading a display or keypad, the additional current drain on a battery can significantly reduce overall talk time. Thus, to overcome this disadvantage, the present invention accounts for actual usage by a user by sensing a talk condition. A talk condition should generally be understood as the condition when a user is on an active call and speaking into the microphone 20 or listening to the earpiece 22. A light

source in the portable communication device **10** should also be understood as being either the display device itself, a light source for backlighting the display device, and a light source for backlighting the keypad of the portable communication device. Of course, other illumination devices that can be used in a portable communication are contemplated within the present invention.” Perez at [0014].

“A talk condition can be sensed in quite a number of ways. After the talk condition is detected or sensed, at least one or more among the display **12**, the backlight **14** (for the display), or the backlight **19** (for the keypad) can be turned off or at least operate at a reduced power level. A talk condition, for example, can be sensed by detecting if a predetermined volume of acoustic sound is being received at the microphone **20** or at another sensor such as a proximity sensor **26** indicative of a user talking on the portable communication device. The sensors **20** or **26** can detect if a predetermined volume of acoustic sound is being received at either sensor. Alternatively, a talk condition can be sensed by measuring at least one among a spectrum density or a spectrum energy of a bounced signal to determine the proximity of a user's head to an earpiece of the portable communication device using a microphone or a proximity sensor **24** as further detailed with respect to FIG. 3. A talk condition can also be sensed by detecting an angle at which the portable communication device **10** is positioned or by detecting a vibration of the portable communication device **10**. There is no need to keep the display **12** on if the phone is sitting idle. Ergonomically, a phone will be used at a certain predetermined angle-range anytime a phone call is active and the user is listening to the earpiece. A sensor **28** for sensing either the angle or a vibration of the portable communication device can be embodied by a microelectronic mechanical systems (MEMS) device. Another way for sensing a talk condition can be achieved by sensing if the portable communication device **10** is in a user's hand. A sensor **30** can be a differential pressure sensor or a thermal sensor that indicates that the phone is in a user's hands. All the sensors described above should be considered environmental sensors with respect to the present invention.” Perez at [0015].

“In yet another alternative, sensing a talk condition can involve simply measuring a predetermined period after a phone call starts. The predetermined time period can be user selectable and can be programmed using the processor **16** as a timer. After the phone call starts and upon expiration of the predetermined period, the processor **16** can be programmed to shut off or reduce power to the display **12** or other illumination sources in the portable communication device **10**.” Perez at [0016].

	<p>“As mentioned previously, the step of detecting a talk condition can be achieved by monitoring or detecting at least one among the conditions of a) detecting if a predetermined volume of acoustic sound is being received at a microphone indicative of a user talking on the portable communication device; b) measuring at least one among a spectrum density and a spectrum energy of a bounced signal to determine the proximity of a user's head to an earpiece of the portable communication device; c) measuring a predetermined period after a phone call starts; d) detecting an angle at which the portable communication device is positioned; e) detecting a vibration of the portable communication device; or f) detecting if the portable communication device is in a user's hand. How the method 50 can detect the conditions described above can be embodied in many different forms using individually or in combination sensors and timers and other devices.” Perez at [0022].</p>
<p>[1c] (b) receive the signal from the proximity sensor; and</p>	<p>Perez discloses the microprocessor adapted to receive the signal from the proximity sensor.</p> <p>For example: <i>see</i> discussion of claim element [1b], <i>supra</i>, which is incorporated herein by reference.</p> <p>“The sensor can be used for detecting a user condition of the portable communication device such as a talk condition when the user is assumed to be talking on the portable communication product. The processor can be programmed to at least reduce power provided to the display when the sensor detects the talk condition.” Perez at Abstract.</p> <p>“In a first aspect of the present invention, a portable communication device comprises a transceiver radio, a display coupled to the transceiver radio, a sensor and a processor. The sensor can be used for detecting a user condition of the portable communication device such as a talk condition when the user is assumed to be talking on the portable communication device. The processor can be programmed to at least reduce power provided to the display when the sensor detects the talk condition. The processor can also turn off power to the display during a talk condition if desired.” Perez at [0006].</p>

“In a second aspect of the present invention, a portable communication device comprises a transceiver radio, a light source coupled to the transceiver radio, an environmental sensor and a processor. The environmental sensor can be used for detecting a user condition of the portable communication device such as a talk condition when the user is assumed to be talking on the portable communication device and the processor can be programmed to at least reduce power provided to the light source when the sensor detects the talk condition.” Perez at [0007].

FIG. 3 is a block diagram of a digital signal processor and coder/decoder used as a sensor for acoustic feedback for determining proximity in accordance with the present invention. Perez at [0012].

“Referring to FIG. 1, a portable communication product **10** such as a cellular phone includes a transceiver radio having a microphone **20**, an earpiece **22**, a keypad **18** and a display **12** (such as a color display) coupled to the transceiver radio. The portable communication product **10** further includes at least one sensor (24, 26, 28 or 30) and a processor **16**. The sensor can be used for detecting a user condition of the portable communication device such as a talk condition when the user is assumed to be talking on the portable communication device. The processor **16** can be programmed to at least reduce power provided to the display **12** when the sensor detects the talk condition. The processor **16** can also turn off power to the display **12** during a talk condition if desired.” Perez at [0013].

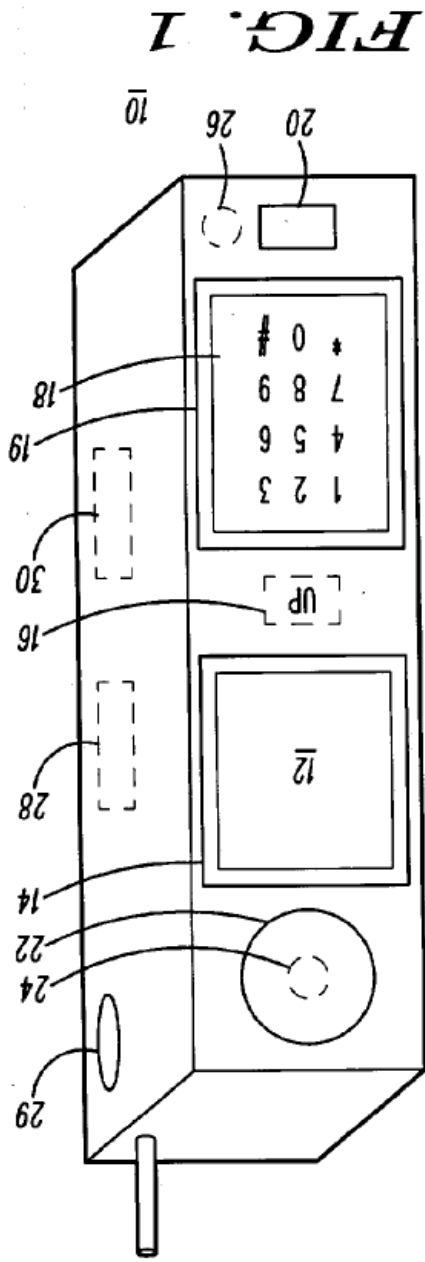

Perez at Fig. 1.

“A talk condition, for example, can be sensed by detecting if a predetermined volume of acoustic sound is being received at the microphone 20 or at another sensor such as a proximity sensor 26 indicative of a user talking on the portable communication device. The sensors 20 or 26 can detect if a predetermined volume of acoustic sound is being received at either sensor. Alternatively, a talk condition can be sensed by measuring at least one among a spectrum density or a spectrum energy of a bounced signal to determine the proximity of a user's head to an earpiece of the portable communication device using a microphone or a proximity sensor 24 as further detailed with respect to FIG. 3 Another way for sensing a talk condition can be achieved by sensing if the portable communication device 10 is in a user's hand. A sensor 30 can be a differential pressure sensor or a thermal sensor that indicates that the phone is in a user's hands. All the sensors described above should be considered environmental sensors with respect to the present invention.”
Perez at [0015].

“In one particular embodiment as shown in FIG. 3, the sensor or sensors 100 can comprise the earpiece 22, the microphone 24, a coder/decoder 104 and a digital signal processor (DSP) 102. The sensor 100 can utilize an acoustic feedback algorithm that measures at least a spectrum density or a spectrum energy of a bounced signal to determine the proximity of a user's head to the earpiece 22 of the portable communication device. The sensor 100 can also be used to control the outbound audio quality or provide a constant audio level (from the perspective of the user) by automatically adjusting the audio level based on the proximity to the ear of the user. This automatic adjustment can additionally lower the power consumption by the audio coder/decoder 104.” Perez at [0019].

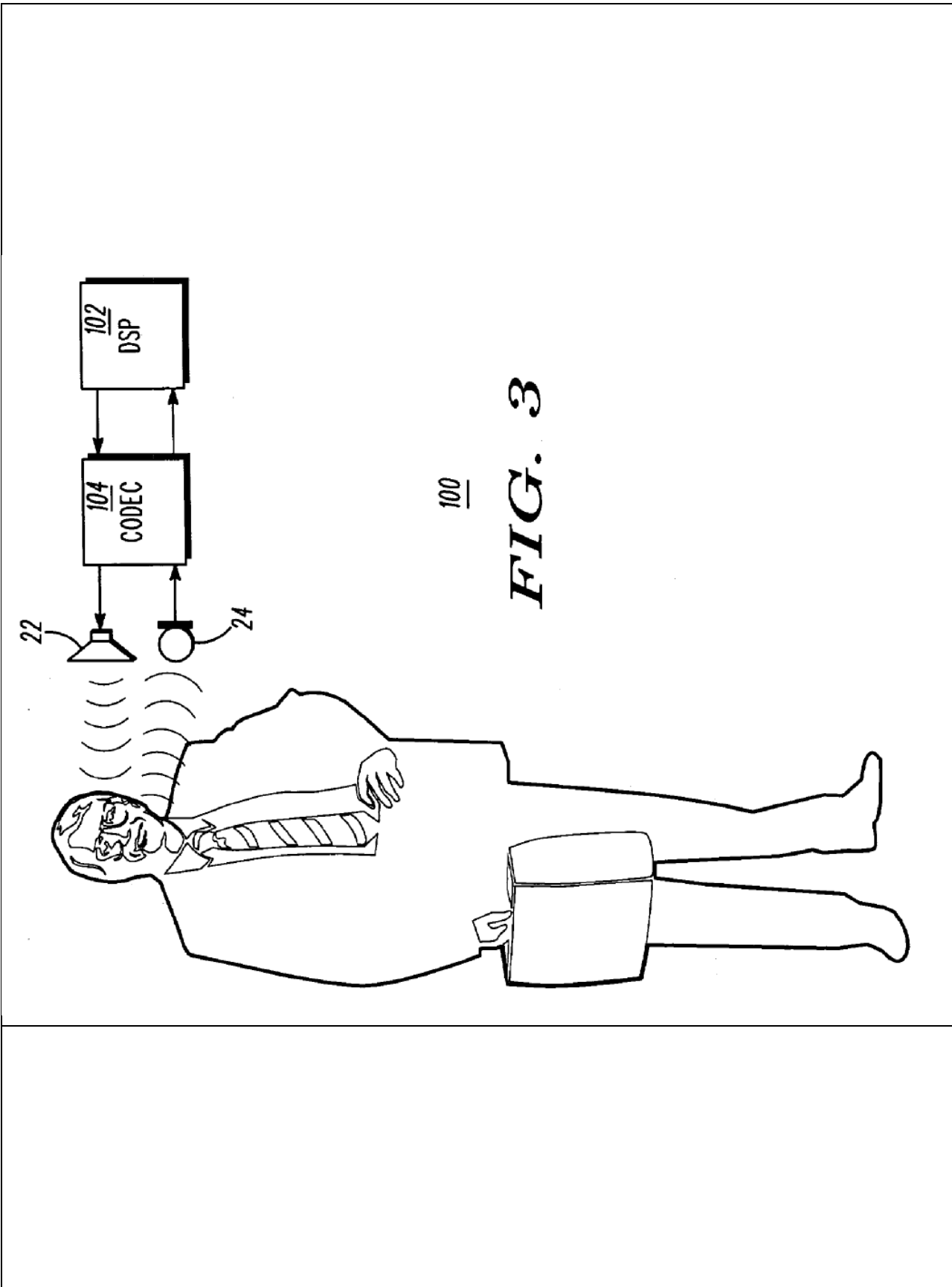

100
FIG. 3

	<p>Perez at Fig. 3.</p> <p>“1. A portable communication device, comprising: a transceiver radio; a display coupled to the transceiver radio; a sensor for detecting a user condition of the portable communication device, wherein the user condition can comprise a talk condition when the user is assumed to be talking on the portable communication device; and a processor programmed to at least reduce power provided to the display when the sensor detects the talk condition.” Perez at Claim 1.</p>
<p>[1f] (c) reduce power to the display if (i) the microprocessor determines that a telephone call is active and (ii) the signal indicates the proximity of the external object; wherein:</p>	<p>Perez discloses the microprocessor adapted to reduce power to the display if (i) the microprocessor determines that a telephone call is active and (ii) the signal indicates the proximity of the external object.</p> <p>For example: <i>see</i> discussions of claim elements [1b], [1d], [1e], [1e], <i>supra</i>, which are incorporated herein by reference.</p> <p>“A portable communication product (10) such as a cellular phone includes a transceiver radio having a microphone (20), an earpiece (22), a keypad (18) and a display (12) coupled to the transceiver radio. The portable communication product further includes at least one sensor (24, 26, 28, or 30) and a processor (16). The sensor can be used for detecting a user condition of the portable communication device such as a talk condition when the user is assumed to be talking on the portable communication product. The processor</p>

can be programmed to at least reduce power provided to the display when the sensor detects the talk condition.” Perez at Abstract.

“A method and apparatus for display power management in a portable communication device can provide additional battery savings to enable increased talk times and standby times without altering current battery technology. Embodiments in accordance with the present invention take advantage of actual usage patterns of users of portable phones to reduce current drain by displays and other illumination sources in cellular phones and other portable communication devices.” Perez at [0005].

“In a first aspect of the present invention, a portable communication device comprises a transceiver radio, a display coupled to the transceiver radio, a sensor and a processor. The sensor can be used for detecting a user condition of the portable communication device such as a talk condition when the user is assumed to be talking on the portable communication device. The processor can be programmed to at least reduce power provided to the display when the sensor detects the talk condition. The processor can also turn off power to the display during a talk condition if desired.” Perez at [0006].

“In a second aspect of the present invention, a portable communication device comprises a transceiver radio, a light source coupled to the transceiver radio, an environmental sensor and a processor. The environmental sensor can be used for detecting a user condition of the portable communication device such as a talk condition when the user is assumed to be talking on the portable communication device and the processor can be programmed to at least reduce power provided to the light source when the sensor detects the talk condition.” Perez at [0007].

“In a third aspect of the present invention, a method of power management for a radio communication device having a display comprises the steps of detecting a talking condition and at least reducing the power provided to the display within a predetermined time of the talking condition.” Perez at [0008]

“The step of detecting a talk condition can be selected from the group of conditions consisting of a) detecting if a predetermined volume of acoustic sound is being received at a microphone indicative of a user talking on the portable communication device; b) measuring at least one among a spectrum density and a spectrum energy of a bounced signal to determine the proximity of a user's head to an earpiece of the portable communication device; c) measuring a predetermined period after a phone call starts; d) detecting an angle at which the portable communication device is positioned; e) detecting a vibration of the portable communication device; and f) detecting if the portable communication device is in a user's hand.” Perez at [0009].

“Referring to FIG. 1, a portable communication product **10** such as a cellular phone includes a transceiver radio having a microphone **20**, an earpiece **22**, a keypad **18** and a display **12** (such as a color display) coupled to the transceiver radio. The portable communication product **10** further includes at least one sensor (**24**, **26**, **28** or **30**) and a processor **16**. The sensor can be used for detecting a user condition of the portable communication device such as a talk condition when the user is assumed to be talking on the portable communication device. The processor **16** can be programmed to at least reduce power provided to the display **12** when the sensor detects the talk condition. The processor **16** can also turn off power to the display **12** during a talk condition if desired.” Perez at [0013].

“In one embodiment, the portable communication device **10** can also include other illumination or lighting devices. For example, the display **12** can have backlighting **14** and/or the keypads can have backlighting **19** as is well known in the industry. Although backlighting provides great ergonomic benefits to a user in visually reading a display or keypad, the additional current drain on a battery can significantly reduce overall talk time. Thus, to overcome this disadvantage, the present invention accounts for actual usage by a user by sensing a talk condition. A talk condition should generally be understood as the condition when a user is on an active call and speaking into the microphone **20** or listening to the earpiece **22**. A light source in the portable communication device **10** should also be understood as being either the display device itself, a light source for backlighting the display device, and a light source for backlighting the keypad of the

portable communication device. Of course, other illumination devices that can be used in a portable communication are contemplated within the present invention.” Perez at [0014].

“A talk condition can be sensed in quite a number of ways. After the talk condition is detected or sensed, at least one or more among the display **12**, the backlight **14** (for the display), or the backlight **19** (for the keypad) can be turned off or at least operate at a reduced power level. A talk condition, for example, can be sensed by detecting if a predetermined volume of acoustic sound is being received at the microphone **20** or at another sensor such as a proximity sensor **26** indicative of a user talking on the portable communication device. The sensors **20** or **26** can detect if a predetermined volume of acoustic sound is being received at either sensor. Alternatively, a talk condition can be sensed by measuring at least one among a spectrum density or a spectrum energy of a bounced signal to determine the proximity of a user's head to an earpiece of the portable communication device using a microphone or a proximity sensor **24** as further detailed with respect to FIG. 3. A talk condition can also be sensed by detecting an angle at which the portable communication device **10** is positioned or by detecting a vibration of the portable communication device **10**. There is no need to keep the display **12** on if the phone is sitting idle. Ergonomically, a phone will be used at a certain predetermined angle-range anytime a phone call is active and the user is listening to the earpiece. A sensor **28** for sensing either the angle or a vibration of the portable communication device can be embodied by a microelectronic mechanical systems (MEMS) device. Another way for sensing a talk condition can be achieved by sensing if the portable communication device **10** is in a user's hand. A sensor **30** can be a differential pressure sensor or a thermal sensor that indicates that the phone is in a user's hands. All the sensors described above should be considered environmental sensors with respect to the present invention.” Perez at [0015].

“In yet another alternative, sensing a talk condition can involve simply measuring a predetermined period after a phone call starts. The predetermined time period can be user selectable and can be programmed using the processor **16** as a timer. After the phone call starts and upon expiration of the predetermined period, the processor **16** can be programmed to shut off or reduce power to the display **12** or other illumination sources in the portable communication device **10**.” Perez at [0016].

“Using the sensors **20, 22, 24, 26, 28** or **30** in combination with the processor **16**, the portable communication device **10** can turn off or reduce the power provided to at least one among the display **12**, the backlight **14**, or a light source (**19**) for the backlit keypad **18** when the portable communication device **10** is in a talk condition. Power for the light sources can be reduced or turned off either immediately upon detection of a talk condition or within a predetermined time as may be programmed into the portable communication device **10**. The shorter the predetermined time period, the more power that will likely be saved. The predetermined time period can be one (1) second for example. As mentioned above, the present invention takes account of actual user behavior and eliminates wasteful power consumption during periods when a user would normally not be looking at his or her display or keypad.” Perez at [0018].

“As mentioned previously, the step of detecting a talk condition can be achieved by monitoring or detecting at least one among the conditions of a) detecting if a predetermined volume of acoustic sound is being received at a microphone indicative of a user talking on the portable communication device; b) measuring at least one among a spectrum density and a spectrum energy of a bounced signal to determine the proximity of a user's head to an earpiece of the portable communication device; c) measuring a predetermined period after a phone call starts; d) detecting an angle at which the portable communication device is positioned; e) detecting a vibration of the portable communication device; or f) detecting if the portable communication device is in a user's hand. How the method **50** can detect the conditions described above can be embodied in many different forms using individually or in combination sensors and timers and other devices.” Perez at [0022].

“1. A portable communication device, comprising:

a transceiver radio;

a display coupled to the transceiver radio;

a sensor for detecting a user condition of the portable communication device, wherein the user condition can comprise a talk condition when the user is assumed to be talking on the portable communication device; and

a processor programmed to at least reduce power provided to the display when the sensor detects the talk condition.” Perez at Claim 1.

“5. The portable communication device of claim 1, wherein the sensor comprises a proximity sensor for detecting if a predetermined volume of acoustic sound is being received at a microphone indicative of a user talking on the portable communication device.” Perez at Claim 5.

“6. The portable communication device of claim 1, wherein the sensor comprises an acoustic feedback algorithm that measures at least one among a spectrum density and a spectrum energy of a bounced signal to determine the proximity of a user's head to an earpiece of the portable communication device.” Perez at Claim 6.

“18. A method of power management for a radio communication device having a display, comprising the steps of:

detecting a talk condition;

at least reducing the power provided to the display within a predetermined time of the talk condition.” Perez at Claim 18.

“20. The method of claim 18, wherein the step of detecting a talk condition is selected from the group of conditions consisting of a) detecting if a predetermined volume of acoustic sound is being received at a microphone indicative of a user talking on the portable communication device; b) measuring at least one among a spectrum density and a spectrum energy of a bounced signal to determine the proximity of a user's head to an earpiece of the portable communication device; c) measuring a predetermined period after a phone call starts; d) detecting an angle at which the portable communication device is positioned; e)

	<p>detecting a vibration of the portable communication device; and f) detecting if the portable communication device is in a user's hand.” Perez at Claim 20.</p> <p>To the extent Perez is deemed to not expressly disclose this claim limitation, Perez inherently discloses this limitation. <i>See</i> discussion of claim element [1h], <i>infra</i>, which is incorporated herein by reference.</p> <p>To the extent Perez is deemed to not expressly or inherently disclose this claim limitation, Perez renders it obvious to one of skill in the art at the time of the alleged invention. <i>See</i> discussion of claim element [1h], <i>infra</i>, which is incorporated herein by reference.</p> <p>To the extent Perez is deemed to not expressly or inherently disclose this claim element, it would be obvious to combine the disclosure of Perez with those of Fukiharu 598 as described in the Fukiharu 598 claim chart, which is incorporated herein in its entirety by reference. <i>See</i> discussion of claim element [1h], <i>infra</i>, which is incorporated herein by reference.</p> <p>To the extent Perez is deemed to not expressly or inherently disclose this claim element, it would be obvious to combine the disclosure of Perez with those of Numazawa as described in the Numazawa claim chart, which is incorporated herein in its entirety by reference. <i>See</i> discussion of claim element [1h], <i>infra</i>, which is incorporated herein by reference.</p> <p>To the extent Perez is deemed to not expressly or inherently disclose this claim element, it would be obvious to combine the disclosure of Perez with those of Miyashita as described in the Miyashita claim chart, which is incorporated herein in its entirety by reference. <i>See</i> discussion of claim element [1h], <i>infra</i>, which is incorporated herein by reference.</p>
<p>[1g] the telephone call is a wireless telephone call;</p>	<p>Perez discloses the telephone call as a wireless telephone call.</p> <p>For example: <i>see</i> discussions of claim elements [1a] and [1d], <i>supra</i>, which are incorporated herein by reference.</p>

“Power management in portable communication devices is an ever-present issue now being further exacerbated by the popular introduction and use of larger color displays with white LED backlights. User talk times are significantly affected because most of these large color displays remain on during phone calls. Existing phones fail to take advantage of some patterns exhibited by handset users as a means to reduce current drain. A typical user averaging a three (3) minute phone call will perceive a noticeable reduction in talk time due to the fact that both a backlight and a display remain on while the call is active. Some phones also include backlit keypads that remain illuminated as well during an active call.” Perez at [0003].

“Portable phones generally keep their display on at all times during a call while the backlight is typically turned off after 30 seconds of no key-activity (user selectable). The 30 seconds that the backlight remains on combined with a display that is not turned off during a phone call substantially affects the talk times based on the actual usage pattern. In some phones, this method may not be sufficiently efficient enough because it may leave the backlight turned on (using 40-60 mA) up to a significant percentage of each phone call time. With displays and illumination mechanisms in portable communication products increasingly vying for additional power from a portable battery, existing methods fail to provide adequate talk and standby times demanded by consumers.” Perez at [0004].

“1. A portable communication device, comprising:

a transceiver radio;

a display coupled to the transceiver radio;

a sensor for detecting a user condition of the portable communication device, wherein the user condition can comprise a talk condition when the user is assumed to be talking on the portable communication device; and

a processor programmed to at least reduce power provided to the display when the sensor detects the talk condition.” Perez at Claim 1.

	<p>“9. The portable communication device of claim 1, wherein the sensor comprises a timer for measuring a predetermined period after a phone call starts and upon expiration of the predetermined period the processor is further programmed to shut off the display.” Perez at Claim 9.</p>
<p>[1h] the microprocessor reduces power to the display while the signal indicates the proximity of the external object only if the microprocessor determines that the wireless telephone call is active; and</p>	<p>Perez discloses that the microprocessor reduces power to the display while the signal indicates the proximity of the external object only if the microprocessor determines that the wireless telephone call is active.</p> <p>For example: <i>see</i> discussion of claim element [1f], <i>supra</i>, which is incorporated herein by reference.</p> <p>The step of detecting a talk condition can be selected from the group of conditions consisting of a) detecting if a predetermined volume of acoustic sound is being received at a microphone indicative of a user talking on the portable communication device; b) measuring at least one among a spectrum density and a spectrum energy of a bounced signal to determine the proximity of a user's head to an earpiece of the portable communication device; c) measuring a predetermined period after a phone call starts; d) detecting an angle at which the portable communication device is positioned; e) detecting a vibration of the portable communication device; and f) detecting if the portable communication device is in a user's hand. Perez at [0019].</p> <p>“In one embodiment, the portable communication device 10 can also include other illumination or lighting devices. For example, the display 12 can have backlighting 14 and/or the keypads can have backlighting 19 as is well known in the industry. Although backlighting provides great ergonomic benefits to a user in visually reading a display or keypad, the additional current drain on a battery can significantly reduce overall talk time. Thus, to overcome this disadvantage, the present invention accounts for actual usage by a user by sensing a talk condition. A talk condition should generally be understood as the condition when a user is on an active call and speaking into the microphone 20 or listening to the earpiece 22. A light source in the portable communication device 10 should also be understood as being either the display device</p>

itself, a light source for backlighting the display device, and a light source for backlighting the keypad of the portable communication device. Of course, other illumination devices that can be used in a portable communication are contemplated within the present invention.” Perez at [0014].

“A talk condition can be sensed in quite a number of ways. After the talk condition is detected or sensed, at least one or more among the display **12**, the backlight **14** (for the display), or the backlight **19** (for the keypad) can be turned off or at least operate at a reduced power level. A talk condition, for example, can be sensed by detecting if a predetermined volume of acoustic sound is being received at the microphone **20** or at another sensor such as a proximity sensor **26** indicative of a user talking on the portable communication device. The sensors **20** or **26** can detect if a predetermined volume of acoustic sound is being received at either sensor. Alternatively, a talk condition can be sensed by measuring at least one among a spectrum density or a spectrum energy of a bounced signal to determine the proximity of a user's head to an earpiece of the portable communication device using a microphone or a proximity sensor **24** as further detailed with respect to FIG. 3. A talk condition can also be sensed by detecting an angle at which the portable communication device **10** is positioned or by detecting a vibration of the portable communication device **10**. There is no need to keep the display **12** on if the phone is sitting idle. Ergonomically, a phone will be used at a certain predetermined angle-range anytime a phone call is active and the user is listening to the earpiece. A sensor **28** for sensing either the angle or a vibration of the portable communication device can be embodied by a microelectronic mechanical systems (MEMS) device. Another way for sensing a talk condition can be achieved by sensing if the portable communication device **10** is in a user's hand. A sensor **30** can be a differential pressure sensor or a thermal sensor that indicates that the phone is in a user's hands. All the sensors described above should be considered environmental sensors with respect to the present invention.” Perez at [0015].

“In yet another alternative, sensing a talk condition can involve simply measuring a predetermined period after a phone call starts. The predetermined time period can be user selectable and can be programmed using the processor **16** as a timer. After the phone call starts and upon expiration of the predetermined period, the processor **16** can be programmed to shut off or reduce power to the display **12** or other illumination sources in the portable communication device **10**.” Perez at [0016].

“Using the sensors **20**, **22**, **24**, **26**, **28** or **30** in combination with the processor **16**, the portable communication device **10** can turn off or reduce the power provided to at least one among the display **12**, the backlight **14**, or a light source (**19**) for the backlit keypad **18** when the portable communication device **10** is in a talk condition. Power for the light sources can be reduced or turned off either immediately upon detection of a talk condition or within a predetermined time as may be programmed into the portable communication device **10**. The shorter the predetermined time period, the more power that will likely be saved. The predetermined time period can be one (1) second for example. As mentioned above, the present invention takes account of actual user behavior and eliminates wasteful power consumption during periods when a user would normally not be looking at his or her display or keypad.” Perez at [0018].

“As mentioned previously, the step of detecting a talk condition can be achieved by monitoring or detecting at least one among the conditions of a) detecting if a predetermined volume of acoustic sound is being received at a microphone indicative of a user talking on the portable communication device; b) measuring at least one among a spectrum density and a spectrum energy of a bounced signal to determine the proximity of a user's head to an earpiece of the portable communication device; c) measuring a predetermined period after a phone call starts; d) detecting an angle at which the portable communication device is positioned; e) detecting a vibration of the portable communication device; or f) detecting if the portable communication device is in a user's hand. How the method **50** can detect the conditions described above can be embodied in many different forms using individually or in combination sensors and timers and other devices.” Perez at [0022].

“1. A portable communication device, comprising:

a transceiver radio;

a display coupled to the transceiver radio;

a sensor for detecting a user condition of the portable communication device, wherein the user condition can comprise a talk condition when the user is assumed to be talking on the portable communication device; and

a processor programmed to at least reduce power provided to the display when the sensor detects the talk condition.” Perez at Claim 1.

“5. The portable communication device of claim 1, wherein the sensor comprises a proximity sensor for detecting if a predetermined volume of acoustic sound is being received at a microphone indicative of a user talking on the portable communication device.” Perez at Claim 5.

“6. The portable communication device of claim 1, wherein the sensor comprises an acoustic feedback algorithm that measures at least one among a spectrum density and a spectrum energy of a bounced signal to determine the proximity of a user's head to an earpiece of the portable communication device.” Perez at Claim 6.

“18. A method of power management for a radio communication device having a display, comprising the steps of:
detecting a talk condition;

at least reducing the power provided to the display within a predetermined time of the talk condition.” Perez at Claim 18.

“20. The method of claim 18, wherein the step of detecting a talk condition is selected from the group of conditions consisting of a) detecting if a predetermined volume of acoustic sound is being received at a microphone indicative of a user talking on the portable communication device; b) measuring at least one

among a spectrum density and a spectrum energy of a bounced signal to determine the proximity of a user's head to an earpiece of the portable communication device; c) measuring a predetermined period after a phone call starts; d) detecting an angle at which the portable communication device is positioned; e) detecting a vibration of the portable communication device; and f) detecting if the portable communication device is in a user's hand." Perez at Claim 20.

To the extent Perez is deemed to not expressly disclose that "the microprocessor reduces power to the display while the signal indicates the proximity of the external object only if the microprocessor determines that the wireless telephone call is active," Perez inherently discloses this limitation. The goal of Perez is to determine when a mobile station is in a "talk condition" in order to determine that the user is unlikely to be looking at the mobile station's display and that it can therefore be powered off and battery power can be conserved. *See, e.g.*, Perez at ¶ 0014 ("For example, the display 12 can have backlighting 14 and/or the keypads can have backlighting 19 as is well known in the industry. Although backlighting provides great ergonomic benefits to a user in visually reading a display or keypad, the additional current drain on a battery can significantly reduce overall talk time. Thus, to overcome this disadvantage, the present invention accounts for actual usage by a user by sensing a talk condition. A talk condition should generally be understood as the condition when a user is on an active call and speaking into the microphone 20 or listening to the earpiece 22"); Perez at Abstract ("A portable communication product (10) such as a cellular phone includes a transceiver radio having a microphone (20), an earpiece (22), a keypad (18) and a display (12) coupled to the transceiver radio. The portable communication product further includes at least one sensor (24, 26, 28, or 30) and a processor (16). The sensor can be used for detecting a user condition of the portable communication device such as a talk condition when the user is assumed to be talking on the portable communication product. The processor can be programmed to at least reduce power provided to the display when the sensor detects the talk condition."). Perez also discloses a number of in which a "talk condition" can be detected, including by detecting a certain volume of acoustic sound or detecting the proximity of user's head to the mobile station. *See, e.g.*, Perez at 0018 ("As mentioned previously, the step of detecting a talk condition can be achieved by monitoring or detecting at least one among the conditions of a) detecting if a predetermined volume of acoustic sound is being received at a microphone indicative of a user talking on the portable communication device; b) measuring at least one among a spectrum density and a spectrum energy of a bounced signal to determine the proximity of a user's head to an earpiece of the

portable communication device; c) measuring a predetermined period after a phone call starts; d) detecting an angle at which the portable communication device is positioned; e) detecting a vibration of the portable communication device; or f) detecting if the portable communication device is in a user's hand. How the method 50 can detect the conditions described above can be embodied in many different forms using individually or in combination sensors and timers and other devices.”). A person of ordinary skill in the art at the time of the alleged invention would understand that Perez, which seeks to conserve battery power by accounting for “actual usage by a user” is necessarily disclosing implement at least one other of its disclosed ways of detecting the talk condition in addition to detecting the “proximity of user’s head” to ensure that the “wireless telephone call is active” before powering off the display of the mobile station. Therefore, a person of ordinary skill in the art at the time of the alleged invention would understand that in Perez, necessarily “the microprocessor reduces power to the display while the signal indicates the proximity of the external object only if the microprocessor determines that the wireless telephone call is active.”

To the extent Perez is deemed to not expressly or inherently disclose that “the microprocessor reduces power to the display while the signal indicates the proximity of the external object only if the microprocessor determines that the wireless telephone call is active,” Perez renders this limitation obvious to one of ordinary skill in the art at the time of the alleged invention. The goal of Perez is to determine when a mobile station is in a “talk condition” in order to determine that the user is unlikely to be looking at the mobile station’s display and that it can therefore be powered off and battery power can be conserved. *See, e.g.*, Perez at ¶ 0014 (“For example, the display 12 can have backlighting 14 and/or the keypads can have backlighting 19 as is well known in the industry. Although backlighting provides great ergonomic benefits to a user in visually reading a display or keypad, the additional current drain on a battery can significantly reduce overall talk time. Thus, to overcome this disadvantage, the present invention accounts for actual usage by a user by sensing a talk condition. A talk condition should generally be understood as the condition when a user is on an active call and speaking into the microphone 20 or listening to the earpiece 22”); Perez at Abstract (“A portable communication product (10) such as a cellular phone includes a transceiver radio having a microphone (20), an earpiece (22), a keypad (18) and a display (12) coupled to the transceiver radio. The portable communication product further includes at least one sensor (24, 26, 28, or 30) and a processor (16). The sensor can be used for detecting a user condition of the portable communication device such as a talk condition when the user is assumed to be talking on the portable communication product. The

processor can be programmed to at least reduce power provided to the display when the sensor detects the talk condition.”). Perez also discloses a number of in which a “talk condition” can be detected, including by detecting a certain volume of acoustic sound or detecting the proximity of user’s head to the mobile station. *See, e.g.*, Perez at 0018 (“As mentioned previously, the step of detecting a talk condition can be achieved by monitoring or detecting at least one among the conditions of a) detecting if a predetermined volume of acoustic sound is being received at a microphone indicative of a user talking on the portable communication device; b) measuring at least one among a spectrum density and a spectrum energy of a bounced signal to determine the proximity of a user’s head to an earpiece of the portable communication device; c) measuring a predetermined period after a phone call starts; d) detecting an angle at which the portable communication device is positioned; e) detecting a vibration of the portable communication device; or f) detecting if the portable communication device is in a user’s hand. How the method 50 can detect the conditions described above can be embodied in many different forms using individually or in combination sensors and timers and other devices.”). It would be obvious to one of ordinary skill in the art at the time of the alleged invention to implement at least one of the other ways of detecting a “talk condition” disclosed in Perez in addition to detecting the “proximity of user’s head,” so as to ensure that the “wireless telephone call is active” before powering off the display of the mobile station. This would be in keeping with Perez’s goal of conserving battery power by accounting for “actual usage by a user.” Doing so would also constitute, at least, combining prior art elements according to known methods to yield predictable results, a simple substitution of one known element for another to obtain predictable results, the use of a known technique to improve similar devices in the same way, the application of a known technique to a known device ready for improvement to yield a predictable result, and obvious to try.

To the extent Perez is deemed to not expressly or inherently disclose that “the microprocessor reduces power to the display while the signal indicates the proximity of the external object only if the microprocessor determines that the wireless telephone call is active,” it would be obvious to combine the disclosure of Perez with those of Fukihara 598 as described in the Fukihara 598 claim chart, which is incorporated herein in its entirety by reference. Perez and Fukihara 598 are both directed to conserving battery power in mobile stations generally and more particularly at conserving battery power in mobile stations by using sensors to detect when the user of the mobile station is in a call and unlikely to be looking at the display (as when, for example, the proximity sensor detects the user’s ear by the mobile station) and to power off the display of mobile stations at such times. Perez at ¶ 0013 (“Referring to FIG. 1, a portable

communication product 10 such as a cellular phone includes a transeiver radio having a microphone 20, an earpiece 22, a keypad 18 and a display 12 (such as a color display) coupled to the transeiver radio. The portable communication product 10 further includes at least one sensor (24, 26, 28 or 30) and a processor 16. The sensor can be used for detecting a user condition of the portable communication device such as a talk condition when the user is assumed to be talking on the portable communication device. The processor 16 can be programmed to at least reduce power provided to the display 12 when the sensor detects the talk condition. The processor 16 can also turn off power to the display 12 during a talk condition if desired.”); Fukiharu 598 at ¶ 0018 (“The present invention, through the use of a structure as described above, enables a reduction in the consumption of battery power, through enabling the lighting devices to be turned OFF when the ear is caused to contact the receiver portion in order to hear the receiver sound during voice communications of a mobile telephone when the lighting devices (backlights) for a liquid crystal display device and keypad portion of a mobile telephone are lit, such as that night.”). A person of ordinary skill in the art at the time of the alleged invention would be motivated to modify Perez such that “the microprocessor reduces power to the display while the signal indicates the proximity of the external object only if the microprocessor determines that the wireless telephone call is active,” as disclosed in Fukihara 598 for a number of different reasons, including that it would support Perez’s ability to conserve battery power in mobile stations, and doing so would be within the knowledge and ability of a person of ordinary skill in the art at the time of the alleged invention. The combination would constitute, at least, combining prior art elements according to known methods to yield predictable results, a simple substitution of one known element for another to obtain predictable results, the use of a known technique to improve similar devices in the same way, the application of a known technique to a known device ready for improvement to yield a predictable result, and obvious to try.

To the extent Perez is deemed to not expressly or inherently disclose the microprocessor adapted to that “the microprocessor reduces power to the display while the signal indicates the proximity of the external object only if the microprocessor determines that the wireless telephone call is active,” it would be obvious to combine the disclosure of Perez with those of Numazawa as described in the Numazawa claim chart, which is incorporated herein in its entirety by reference. Perez and Numazawa are both directed to conserving battery power in mobile stations generally and more particularly at conserving battery power in mobile stations by using sensors to detect when the user of the mobile station is in a call and unlikely to be looking at the display (as when, for example, the proximity sensor detects the user’s ear by the mobile station) and to power off the display of mobile stations at such times. Perez at ¶ 0013 (“Referring to FIG. 1,

a portable communication product 10 such as a cellular phone includes a transceiver radio having a microphone 20, an earpiece 22, a keypad 18 and a display 12 (such as a color display) coupled to the transceiver radio. The portable communication product 10 further includes at least one sensor (24, 26, 28 or 30) and a processor 16. The sensor can be used for detecting a user condition of the portable communication device such as a talk condition when the user is assumed to be talking on the portable communication device. The processor 16 can be programmed to at least reduce power provided to the display 12 when the sensor detects the talk condition. The processor 16 can also turn off power to the display 12 during a talk condition if desired.”); Numazawa at ¶ Abstract (“To achieve reduced power consumption through stopping operation of unnecessary functions during use of a wireless terminal. A CPU 2 identifies start of a call state through a signal from a signal processing portion 3 for controlling communication with a base station, and identifies, through an output signal from detecting means 6, whether or not a user ear is in contact with a terminal. Upon identification of contact of the ear to the terminal, controlling means 8 are caused to stop the supply of electric power, from a power supply 7, to displaying means 9 for providing information to a user, and lighting means 10, such as a black light.”), ¶ 0005-0007 (“In the present invention, control is such that, upon determination that the wireless terminal is in a call, operation of functions believe be unnecessary, due to the user of the terminal being in a call, is stopped, and upon termination of the call, operation of the stopped functions is restarted. Additionally, because it is envisioned that there will also be cases where, even during a call, the face of the user may be separated from the receiver of the terminal, control is performed so as to enable restarting of the operations of the functions that had been stopped as unnecessary, through detecting whether or not the user of the terminal has the receiver in contact with an ear. The achievement of reduced power consumption through stopping operation of functions that become unnecessary in use of the terminal, as described above, can be anticipated to have the effect of extending the life of the power supply, such as a battery.”). A person of ordinary skill in the art at the time of the alleged invention would be motivated to modify Perez such that “the microprocessor reduces power to the display while the signal indicates the proximity of the external object only if the microprocessor determines that the wireless telephone call is active,” as disclosed in Numazawa for a number of different reasons, including that it would support Perez’s ability to conserve battery power in mobile stations, and doing so would be within the knowledge and ability of a person of ordinary skill in the art at the time of the alleged invention. The combination would constitute, at least, combining prior art elements according to known methods to yield predictable results, a simple substitution of one known element for another to obtain predictable results, the use of a known technique to improve similar devices in the same way, the application of a known technique to a known device ready for improvement to yield a predictable result, and obvious to try.

To the extent Perez is deemed to not expressly or inherently disclose that “the microprocessor reduces power to the display while the signal indicates the proximity of the external object only if the microprocessor determines that the wireless telephone call is active,” it would be obvious to combine the disclosure of Perez with those of Miyashita as described in the Miyashita claim chart, which is incorporated herein in its entirety by reference. Perez and Miyashita are both directed to conserving battery power in mobile stations generally and more particularly at conserving battery power in mobile stations by using sensors to detect when the user of the mobile station is in a call and unlikely to be looking at the display (as when, for example, the proximity sensor detects the user’s ear by the mobile station or a sensor detects that the mobile station is in a vertical orientation) and to power off the display of mobile stations at such times. Perez at ¶ 0013 (“Referring to FIG. 1, a portable communication product 10 such as a cellular phone includes a transceiver radio having a microphone 20, an earpiece 22, a keypad 18 and a display 12 (such as a color display) coupled to the transceiver radio. The portable communication product 10 further includes at least one sensor (24, 26, 28 or 30) and a processor 16. The sensor can be used for detecting a user condition of the portable communication device such as a talk condition when the user is assumed to be talking on the portable communication device. The processor 16 can be programmed to at least reduce power provided to the display 12 when the sensor detects the talk condition. The processor 16 can also turn off power to the display 12 during a talk condition if desired.”); Miyashita at 1:58-63 (“The present invention is directed to solving the problem set forth above. It is therefore an object of the present invention to provide a portable telephone set which can shut off the power supply for a display portion while a content of the display will not be seen during speaking, and thus can reduce power consumption.”), 2:6-11 (“In the preferred construction the detector is a gyro. The control apparatus may shut off the power supply for the display when the detector detects the main body at a substantially vertical position. On the other hand, the control may initiate power supply for the display when the detector detects the main body at a substantially horizontal position.”). A person of ordinary skill in the art at the time of the alleged invention would be motivated to modify Perez such that “the microprocessor reduces power to the display while the signal indicates the proximity of the external object only if the microprocessor determines that the wireless telephone call is active,” as disclosed in Miyashita for a number of different reasons, including that it would support Perez’s ability to conserve battery power in mobile stations, and doing so would be within the knowledge and ability of a person of ordinary skill in the art at the time of the alleged invention. The combination would constitute, at least, combining prior art elements according to known methods to yield predictable results, a simple substitution of one known element for another to obtain predictable results, the

<p>[11] the proximity sensor begins detecting whether an external object is proximate substantially concurrently with the mobile station initiating an outgoing wireless telephone call or receiving an incoming wireless telephone call.</p>	<p>use of a known technique to improve similar devices in the same way, the application of a known technique to a known device ready for improvement to yield a predictable result, and obvious to try.</p>
<p>Perez discloses that the proximity sensor begins to detect whether an external object is proximate substantially concurrently with the mobile station initiating an outgoing wireless telephone call or receiving an incoming wireless telephone call:</p> <p>For example: <i>see</i> discussion of claim element [1f], <i>supra</i>, which is incorporated herein by reference.</p> <p>“The step of detecting a talk condition can be selected from the group of conditions consisting of a) detecting if a predetermined volume of acoustic sound is being received at a microphone indicative of a user talking on the portable communication device; b) measuring at least one among a spectrum density and a spectrum energy of a bounced signal to determine the proximity of a user’s head to an earpiece of the portable communication device; c) measuring a predetermined period after a phone call starts; d) detecting an angle at which the portable communication device is positioned; e) detecting a vibration of the portable communication device; and f) detecting if the portable communication device is in a user’s hand.” Perez at [0009].</p> <p>“Referring to FIG. 1, a portable communication product 10 such as a cellular phone includes a transceiver radio having a microphone 20, an earpiece 22, a keypad 18 and a display 12 (such as a color display) coupled to the transceiver radio. The portable communication product 10 further includes at least one sensor (24, 26, 28 or 30) and a processor 16. The sensor can be used for detecting a user condition of the portable communication device such as a talk condition when the user is assumed to be talking on the portable communication device. The processor 16 can be programmed to at least reduce power provided to the display 12 when the sensor detects the talk condition. The processor 16 can also turn off power to the display 12 during a talk condition if desired.” Perez at [0013].</p>	<p>Perez discloses that the proximity sensor begins to detect whether an external object is proximate substantially concurrently with the mobile station initiating an outgoing wireless telephone call or receiving an incoming wireless telephone call:</p> <p>For example: <i>see</i> discussion of claim element [1f], <i>supra</i>, which is incorporated herein by reference.</p> <p>“The step of detecting a talk condition can be selected from the group of conditions consisting of a) detecting if a predetermined volume of acoustic sound is being received at a microphone indicative of a user talking on the portable communication device; b) measuring at least one among a spectrum density and a spectrum energy of a bounced signal to determine the proximity of a user’s head to an earpiece of the portable communication device; c) measuring a predetermined period after a phone call starts; d) detecting an angle at which the portable communication device is positioned; e) detecting a vibration of the portable communication device; and f) detecting if the portable communication device is in a user’s hand.” Perez at [0009].</p> <p>“Referring to FIG. 1, a portable communication product 10 such as a cellular phone includes a transceiver radio having a microphone 20, an earpiece 22, a keypad 18 and a display 12 (such as a color display) coupled to the transceiver radio. The portable communication product 10 further includes at least one sensor (24, 26, 28 or 30) and a processor 16. The sensor can be used for detecting a user condition of the portable communication device such as a talk condition when the user is assumed to be talking on the portable communication device. The processor 16 can be programmed to at least reduce power provided to the display 12 when the sensor detects the talk condition. The processor 16 can also turn off power to the display 12 during a talk condition if desired.” Perez at [0013].</p>

“A talk condition can be sensed in quite a number of ways. After the talk condition is detected or sensed, at least one or more among the display 12, the backlight 14 (for the display), or the backlight 19 (for the keypad) can be turned off or at least operate at a reduced power level. A talk condition, for example, can be sensed by detecting if a predetermined volume of acoustic sound is being received at the microphone 20 or at another sensor such as a proximity sensor 26 indicative of a user talking on the portable communication device. The sensors 20 or 26 can detect if a predetermined volume of acoustic sound is being received at either sensor. Alternatively, a talk condition can be sensed by measuring at least one among a spectrum density or a spectrum energy of a bounced signal to determine the proximity of a user's head to an earpiece of the portable communication device using a microphone or a proximity sensor 24 as further detailed with respect to FIG. 3. A talk condition can also be sensed by detecting an angle at which the portable communication device 10 is positioned or by detecting a vibration of the portable communication device 10. There is no need to keep the display 12 on if the phone is sitting idle. Ergonomically, a phone will be used at a certain predetermined angle-range anytime a phone call is active and the user is listening to the earpiece. A sensor 28 for sensing either the angle or a vibration of the portable communication device can be embodied by a microelectronic mechanical systems (MEMS) device. Another way for sensing a talk condition can be achieved by sensing if the portable communication device 10 is in a user's hand. A sensor 30 can be a differential pressure sensor or a thermal sensor that indicates that the phone is in a user's hands. All the sensors described above should be considered environmental sensors with respect to the present invention.” Perez at [0015].

“As mentioned previously, the step of detecting a talk condition can be achieved by monitoring or detecting at least one among the conditions of a) detecting if a predetermined volume of acoustic sound is being received at a microphone indicative of a user talking on the portable communication device; b) measuring at least one among a spectrum density and a spectrum energy of a bounced signal to determine the proximity of a user's head to an earpiece of the portable communication device; c) measuring a predetermined period after a phone call starts; d) detecting an angle at which the portable communication device is positioned; e) detecting a vibration of the portable communication device; or f) detecting if the portable communication device is in a user's hand. How the method 50 can detect the conditions described above can be embodied in many different forms using individually or in combination sensors and timers and other devices.” Perez at [0022].

“1. A portable communication device, comprising:

a transmitter radio;

a display coupled to the transmitter radio;

a sensor for detecting a user condition of the portable communication device, wherein the user condition can comprise a talk condition when the user is assumed to be talking on the portable communication device; and

a processor programmed to at least reduce power provided to the display when the sensor detects the talk condition.” Perez at Claim 1.

“6. The portable communication device of claim 1, wherein the sensor comprises an acoustic feedback algorithm that measures at least one among a spectrum density and a spectrum energy of a bounced signal to determine the proximity of a user's head to an earpiece of the portable communication device.” Perez at Claim 6.

To the extent Perez is deemed to not expressly disclose “the proximity sensor begins detecting whether an external object is proximate substantially concurrently with the mobile station initiating an outgoing wireless telephone call or receiving an incoming wireless telephone call,” Perez inherently discloses this limitation. In Perez, the use of a proximity sensor is disclosed as one out of several ways that a mobile station can detect that it is in a “talk condition.” *See, e.g.*, Perez at ¶ 0015 (“A talk condition can be sensed in quite a number of ways A talk condition, for example, can be sensed by . . . measuring at least one among a spectrum density or a spectrum energy of a bounced signal to determine the proximity of a user's head to an earpiece of the portable communication device using a microphone or a proximity sensor 24 as further detailed with respect to FIG. 3.”). Perez also discloses that “[a] talk condition should generally be understood as the condition when a user is on an active call and speaking into the microphone 20 or listening to the earpiece 22.” Perez at ¶ 0014. A person of ordinary skill in the art at the time of the alleged invention would understand that “initiating an outgoing wireless telephone call or receiving an incoming wireless telephone call” is how a mobile station enters into a “talk condition.” Further, a person of ordinary skill in the art

would understand that “the proximity sensor begins detecting whether an external object is proximate substantially concurrently with the mobile station initiating an outgoing wireless telephone call or receiving an incoming wireless telephone call” because the function of the proximity sensor in Perez is to detect the “talk condition” so as to disable the display of the mobile station as soon as the detection takes place in order to conserve battery. Thus, a person of ordinary skill in the art at the time of the alleged invention would understand Perez to inherently disclose that “the proximity sensor begins detecting whether an external object is proximate substantially concurrently with the mobile station initiating an outgoing wireless telephone call or receiving an incoming wireless telephone call.”

To the extent Perez is deemed to not expressly or inherently disclose “the proximity sensor begins detecting whether an external object is proximate substantially concurrently with the mobile station initiating an outgoing wireless telephone call or receiving an incoming wireless telephone call,” Perez renders it obvious to one of skill in the art to have “the proximity sensor begin[] detecting whether an external object is proximate substantially concurrently with the mobile station initiating an outgoing wireless telephone call or receiving an incoming wireless telephone call.” A person of ordinary skill in the art at the time of the alleged invention would understand that “initiating an outgoing wireless telephone call or receiving an incoming wireless telephone call” is how a mobile station enters into a “talk condition.” Further, it would be obvious to a person of ordinary skill in the art at the time of the alleged invention for “the proximity sensor [to] begin[] detecting whether an external object is proximate substantially concurrently with the mobile station initiating an outgoing wireless telephone call or receiving an incoming wireless telephone call” because the function of the proximity sensor in Perez is to detect the “talk condition” so as to disable the display of the mobile station as soon as the detection takes place in order to conserve battery. Starting to detect the “talk condition” via the proximity sensor as soon as the mobile station enters into the “talk condition” would support Perez’s goal of battery conservation, and it would be obvious to a person of ordinary skill in the art at the time of the alleged invention that the proximity sensor should begin detecting substantially concurrently with the start of this period in order to save additional power. Doing so would constitute, at least, combining prior art elements according to known methods to yield predictable results, a simple substitution of one known element for another to obtain predictable results, the use of a known technique to improve similar devices in the same way, the application of a known technique to a known device ready for improvement to yield a predictable result, and obvious to try.

To the extent Perez is deemed to not expressly or inherently disclose “the proximity sensor begins detecting whether an external object is proximate substantially concurrently with the mobile station initiating an outgoing wireless telephone call or receiving an incoming wireless telephone call,” it would be obvious to combine the disclosure of Perez with those of Fukiharu 598 as described in the Fukiharu 598 claim chart, which is incorporated herein in its entirety by reference. Perez and Fukiharu 598 are both directed to conserving battery power in mobile stations generally and more particularly at conserving battery power in mobile stations by using sensors to detect when the user of the mobile station is in a call and unlikely to be looking at the display (as when, for example, the proximity sensor detects the user’s ear by the mobile station) and to power off the display of mobile stations at such times. Perez at ¶ 0013 (“Referring to FIG. 1, a portable communication product 10 such as a cellular phone includes a transceiver radio having a microphone 20, an earpiece 22, a keypad 18 and a display 12 (such as a color display) coupled to the transceiver radio. The portable communication product 10 further includes at least one sensor (24, 26, 28 or 30) and a processor 16. The sensor can be used for detecting a user condition of the portable communication device such as a talk condition when the user is assumed to be talking on the portable communication device. The processor 16 can be programmed to at least reduce power provided to the display 12 when the sensor detects the talk condition. The processor 16 can also turn off power to the display 12 during a talk condition if desired.”); Fukiharu 598 at ¶ 0018 (“The present invention, through the use of a structure as described above, enables a reduction in the consumption of battery power, through enabling the lighting devices to be turned OFF when the ear is caused to contact the receiver portion in order to hear the receiver sound during voice communications of a mobile telephone when the lighting devices (backlights) for a liquid crystal display device and keypad portion of a mobile telephone are lit, such as that night.”). A person of ordinary skill in the art at the time of the alleged invention would be motivated to modify Perez to have “the proximity sensor begin[] detecting whether an external object is proximate substantially concurrently with the mobile station initiating an outgoing wireless telephone call or receiving an incoming wireless telephone call” as disclosed in Fukiharu 598 for a number of different reasons, including that it would support Perez’s ability to conserve battery power in mobile stations, and doing so would be within the knowledge and ability of a person of ordinary skill in the art at the time of the alleged invention. The combination would constitute, at least, combining prior art elements according to known methods to yield predictable results, a simple substitution of one known element for another to obtain predictable results, the use of a known technique to improve similar devices in the same way, the application of a known technique to a known device ready for improvement to yield a predictable result, and obvious to try.

To the extent Perez is deemed to not expressly or inherently disclose “the proximity sensor begins detecting whether an external object is proximate substantially concurrently with the mobile station initiating an outgoing wireless telephone call or receiving an incoming wireless telephone call,” it would be obvious to combine the disclosure of Perez with those of Numazawa as described in the Numazawa claim chart, which is incorporated herein in its entirety by reference. Perez and Numazawa are both directed to conserving battery power in mobile stations generally and more particularly at conserving battery power in mobile stations by using sensors to detect when the user of the mobile station is in a call and unlikely to be looking at the display (as when, for example, the proximity sensor detects the user’s ear by the mobile station) and to power off the display of mobile stations at such times. Perez at ¶ 0013 (“Referring to FIG. 1, a portable communication product 10 such as a cellular phone includes a transceiver radio having a microphone 20, an earpiece 22, a keypad 18 and a display 12 (such as a color display) coupled to the transceiver radio. The portable communication product 10 further includes at least one sensor (24, 26, 28 or 30) and a processor 16. The sensor can be used for detecting a user condition of the portable communication device such as a talk condition when the user is assumed to be talking on the portable communication device. The processor 16 can be programmed to at least reduce power provided to the display 12 when the sensor detects the talk condition. The processor 16 can also turn off power to the display 12 during a talk condition if desired.”); Numazawa at ¶ Abstract (“To achieve reduced power consumption through stopping operation of unnecessary functions during use of a wireless terminal. A CPU 2 identifies start of a call state through a signal from a signal processing portion 3 for controlling communication with a base station, and identifies, through an output signal from detecting means 6, whether or not a user ear is in contact with a terminal. Upon identification of contact of the ear to the terminal, controlling means 8 are caused to stop the supply of electric power, from a power supply 7, to displaying means 9 for providing information to a user, and lighting means 10, such as a black light.”), ¶ 0005-0007 (“In the present invention, control is such that, upon determination that the wireless terminal is in a call, operation of functions believe be unnecessary, due to the user of the terminal being in a call, is stopped, and upon termination of the call, operation of the stopped functions is restarted. Additionally, because it is envisioned that there will also be cases where, even during a call, the face of the user may be separated from the receiver of the terminal, control is performed so as to enable restarting of the operations of the functions that had been stopped as unnecessary, through detecting whether or not the user of the terminal has the receiver in contact with an ear. The achievement of reduced power consumption through stopping operation of functions that become unnecessary in use of the terminal, as described above, can be anticipated to have the effect of extending the life of the power supply, such as a battery.”) A person of ordinary skill in the art at the time of the alleged invention would

be motivated to modify Perez to have “the proximity sensor begin[] detecting whether an external object is proximate substantially concurrently with the mobile station initiating an outgoing wireless telephone call or receiving an incoming wireless telephone call” as disclosed in Numazawa for a number of different reasons, including that it would support Perez’s ability to conserve battery power in mobile stations, and doing so would be within the knowledge and ability of a person of ordinary skill in the art at the time of the alleged invention. The combination would constitute, at least, combining prior art elements according to known methods to yield predictable results, a simple substitution of one known element for another to obtain predictable results, the use of a known technique to improve similar devices in the same way, the application of a known technique to a known device ready for improvement to yield a predictable result, and obvious to try.

To the extent Perez is deemed to not expressly or inherently disclose “the proximity sensor begins detecting whether an external object is proximate substantially concurrently with the mobile station initiating an outgoing wireless telephone call or receiving an incoming wireless telephone call,” it would be obvious to combine the disclosure of Perez with those of Miyashita as described in the Miyashita claim chart, which is incorporated herein in its entirety by reference. Perez and Miyashita are both directed to conserving battery power in mobile stations generally and more particularly at conserving battery power in mobile stations by using sensors to detect when the user of the mobile station is in a call and unlikely to be looking at the display (as when, for example, the proximity sensor detects the user’s ear by the mobile station or a sensor detects that the mobile station is in a vertical orientation) and to power off the display of mobile stations at such times. Perez at ¶ 0013 (“Referring to FIG. 1, a portable communication product 10 such as a cellular phone includes a transceiver radio having a microphone 20, an earpiece 22, a keypad 18 and a display 12 (such as a color display) coupled to the transceiver radio. The portable communication product 10 further includes at least one sensor (24, 26, 28 or 30) and a processor 16. The sensor can be used for detecting a user condition of the portable communication device such as a talk condition when the user is assumed to be talking on the portable communication device. The processor 16 can be programmed to at least reduce power provided to the display 12 when the sensor detects the talk condition. The processor 16 can also turn off power to the display 12 during a talk condition if desired.”); Miyashita at 3:58-4:2 (“In contrast, the display control portion 17 is responsive to the inclination angle information indicative of variation of the inclination angle from the substantially horizontal orientation to the substantially vertical orientation while it performs display control for the display portion 16 to display the control information, to terminate the power supply for the display portion 16. When speaking is performed with the destination person via the

	<p>speaker 12 and the microphone 14, it is rare to require seeing the display content on the display portion 16. Therefore, the power supply for the display portion 16 is shut down. Thus, exhausting of a battery can be reduced.’). While Miyashita discloses a gyro, it would be obvious to one of ordinary skill in the art at the time of the alleged invention to make Perez’s proximity sensor to function in the same way as the gyro in Miyashita as both sensors serve the same function (to serve as an indication that the mobile station’s display is unlikely to be viewed and can therefore be powered off). A person of ordinary skill in the art at the time of the alleged invention would therefore be motivated to modify Perez to have “the proximity sensor begin[] detecting whether an external object is proximate substantially concurrently with the mobile station initiating an outgoing wireless telephone call or receiving an incoming wireless telephone call” as disclosed in Miyashita for a number of different reasons, including that it would support Perez’s ability to conserve battery power in mobile stations, and doing so would be within the knowledge and ability of a person of ordinary skill in the art at the time of the alleged invention. The combination would constitute, at least, combining prior art elements according to known methods to yield predictable results, a simple substitution of one known element for another to obtain predictable results, the use of a known technique to improve similar devices in the same way, the application of a known technique to a known device ready for improvement to yield a predictable result, and obvious to try.</p>
<p>[Claim 2] The mobile station of claim 1, wherein the microprocessor reduces power to the display only if (i) the microprocessor determines that a telephone call is active and (ii) the signal indicates the proximity of the external object.</p>	<p>Perez discloses the microprocessor reducing power to the display only if (i) the microprocessor determines that a telephone call is active and (ii) the signal indicates the proximity of the external object.</p> <p>For example: <i>see</i> discussion of claim elements [1f], [1h], <i>supra</i>, which are incorporated herein by reference.</p> <p>To the extent Perez is deemed to not expressly disclose this claim limitation, Perez inherently discloses this limitation. <i>See</i> discussion of claim element [1h], <i>supra</i>, which is incorporated herein by reference.</p> <p>To the extent Perez is deemed to not expressly or inherently disclose this claim limitation, Perez renders it obvious to one of skill in the art at the time of the alleged invention. <i>See</i> discussion of claim element [1h], <i>supra</i>, which is incorporated herein by reference.</p>

	<p>To the extent Perez is deemed to not expressly or inherently disclose this claim element, it would be obvious to combine the disclosure of Perez with those of Fukiharu 598 as described in the Fukiharu 598 claim chart, which is incorporated herein in its entirety by reference. See discussion of claim element [1h], <i>supra</i>, which is incorporated herein by reference.</p> <p>To the extent Perez is deemed to not expressly or inherently disclose this claim element, it would be obvious to combine the disclosure of Perez with those of Numazawa as described in the Numazawa claim chart, which is incorporated herein in its entirety by reference. See discussion of claim element [1h], <i>supra</i>, which is incorporated herein by reference.</p> <p>To the extent Perez is deemed to not expressly or inherently disclose this claim element, it would be obvious to combine the disclosure of Perez with those of Miyashita as described in the Miyashita claim chart, which is incorporated herein in its entirety by reference. See discussion of claim element [1h], <i>supra</i>, which is incorporated herein by reference.</p>
<p>[Claim 4] The mobile station as recited in claim 1, wherein the microprocessor reduces power to the display by turning off the display.</p>	<p>Perez discloses the microprocessor reducing power to the display by turning off the display.</p> <p>For example:</p> <p><i>See</i> discussion of claim element [1f], <i>supra</i>, which is incorporated herein by reference.</p>
<p>[Claim 5] The mobile station as recited in claim 1, wherein the proximity sensor is a mechanical proximity sensor, an</p>	<p>Perez discloses that the proximity sensor is a mechanical proximity sensor, an optical sensor, or a range-detecting sensor.</p> <p>For example:</p>

optical sensor, or a range-detecting sensor.

“A talk condition can be sensed in quite a number of ways. After the talk condition is detected or sensed, at least one or more among the display 12, the backlight 14 (for the display), or the backlight 19 (for the keypad) can be turned off or at least operate at a reduced power level. A talk condition, for example, can be sensed by detecting if a predetermined volume of acoustic sound is being received at the microphone 20 or at another sensor such as a proximity sensor 26 indicative of a user talking on the portable communication device. The sensors 20 or 26 can detect if a predetermined volume of acoustic sound is being received at either sensor. Alternatively, a talk condition can be sensed by measuring at least one among a spectrum density or a spectrum energy of a bounced signal to determine the proximity of a user's head to an earpiece of the portable communication device using a microphone or a proximity sensor 24 as further detailed with respect to FIG. 3. A talk condition can also be sensed by detecting an angle at which the portable communication device 10 is positioned or by detecting a vibration of the portable communication device 10. There is no need to keep the display 12 on if the phone is sitting idle. Ergonomically, a phone will be used at a certain predetermined angle-range anytime a phone call is active and the user is listening to the earpiece. A sensor 28 for sensing either the angle or a vibration of the portable communication device can be embodied by a microelectronic mechanical systems (MEMS) device. Another way for sensing a talk condition can be achieved by sensing if the portable communication device 10 is in a user's hand. A sensor 30 can be a differential pressure sensor or a thermal sensor that indicates that the phone is in a user's hands. All the sensors described above should be considered environmental sensors with respect to the present invention.” Perez at [0015].

“In one particular embodiment as shown in FIG. 3, the sensor or sensors 100 can comprise the earpiece 22, the microphone 24, a coder/decoder 104 and a digital signal processor (DSP) 102. The sensor 100 can utilize an acoustic feedback algorithm that measures at least a spectrum density or a spectrum energy of a bounced signal to determine the proximity of a user's head to the earpiece 22 of the portable communication device. The sensor 100 can also be used to control the outbound audio quality or provide a constant audio level (from the perspective of the user) by automatically adjusting the audio level based on the proximity to the ear of the user. This automatic adjustment can additionally lower the power consumption by the audio coder/decoder 104.” Perez at [0019].

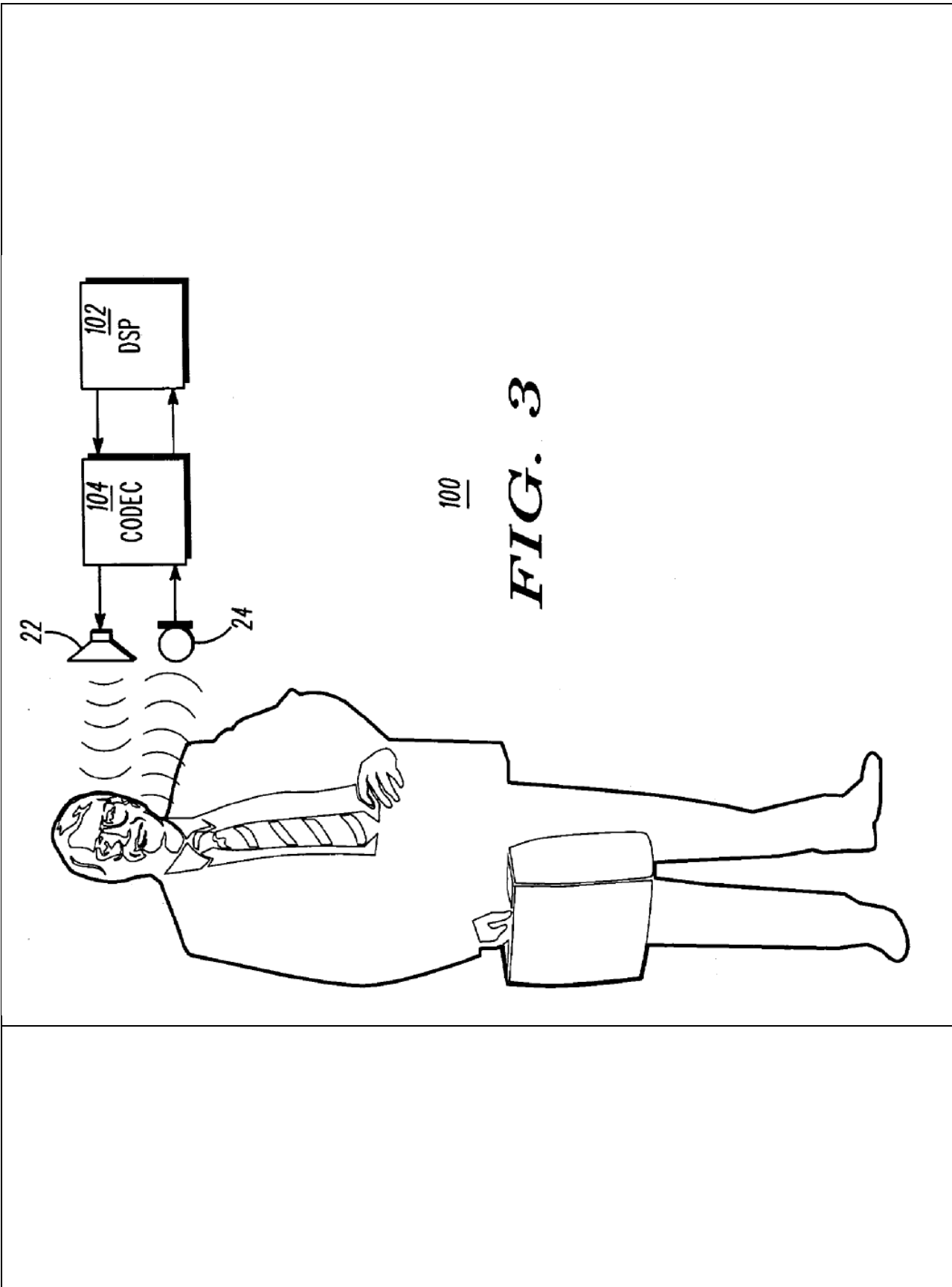

100
FIG. 3

Perez at Fig. 3.

“5. The portable communication device of claim 1, wherein the sensor comprises a proximity sensor for detecting if a predetermined volume of acoustic sound is being received at a microphone indicative of a user talking on the portable communication device.” Perez at Claim 5.

“6. The portable communication device of claim 1, wherein the sensor comprises an acoustic feedback algorithm that measures at least one among a spectrum density and a spectrum energy of a bounced signal to determine the proximity of a user's head to an earpiece of the portable communication device.” Perez at Claim 6.

To the extent Perez is deemed to not expressly or inherently disclose “the proximity sensor is a mechanical proximity sensor, an optical sensor, or a range-detecting sensor,” Perez renders it obvious to one of ordinary skill in the art at the time of the alleged invention to use a mechanical proximity sensor. A person of ordinary skill in the art at the time of the alleged invention would be aware of “conventional mechanical proximity (load) sensors,” which the '889 Patent identifies as known prior art. *See* '889 Patent at 3:15-20. A person of ordinary skill in the art at the time of the alleged invention would understand that a mechanical proximity sensor could be used to detect contact with a portion of the human body, such as an ear. Using a mechanical proximity sensor would constitute, at least, combining prior art elements according to known methods to yield predictable results, a simple substitution of one known element for another to obtain predictable results, the use of a known technique to improve similar devices in the same way, the application of a known technique to a known device ready for improvement to yield a predictable result, and obvious to try.

To the extent Perez is deemed to not expressly or inherently disclose “the proximity sensor is a mechanical proximity sensor, an optical sensor, or a range-detecting sensor,” it would be obvious to combine the disclosure of Perez with those of Fukiharu 598 as described in the Fukiharu 598 claim chart, which is

incorporated herein in its entirety by reference. Perez and Fukiharu 598 are both directed to conserving battery power in mobile stations generally and more particularly at conserving battery power in mobile stations by using sensors to detect when the user of the mobile station is in a call and unlikely to be looking at the display (as when, for example, the proximity sensor detects the user's ear by the mobile station) and to power off the display of mobile stations at such times. Perez at ¶ 0013 (“Referring to FIG. 1, a portable communication product 10 such as a cellular phone includes a transmitter radio having a microphone 20, an earpiece 22, a keypad 18 and a display 12 (such as a color display) coupled to the transmitter radio. The portable communication product 10 further includes at least one sensor (24, 26, 28 or 30) and a processor 16. The sensor can be used for detecting a user condition of the portable communication device such as a talk condition when the user is assumed to be talking on the portable communication device. The processor 16 can be programmed to at least reduce power provided to the display 12 when the sensor detects the talk condition. The processor 16 can also turn off power to the display 12 during a talk condition if desired.”); Fukiharu 598 at ¶ 0018 (“The present invention, through the use of a structure as described above, enables a reduction in the consumption of battery power, through enabling the lighting devices to be turned OFF when the ear is caused to contact the receiver portion in order to hear the receiver sound during voice communications of a mobile telephone when the lighting devices (backlights) for a liquid crystal display device and keypad portion of a mobile telephone are lit, such as that night.”). A person of ordinary skill in the art at the time of the alleged invention would be motivated to modify Perez such that “the proximity sensor is a mechanical proximity sensor, an optical sensor, or a range-detecting sensor,” as disclosed in Fukiharu 598 for a number of different reasons, including that it would support Perez’s ability to conserve battery power in mobile stations, and doing so would be within the knowledge and ability of a person of ordinary skill in the art at the time of the alleged invention. The combination would constitute, at least, combining prior art elements according to known methods to yield predictable results, a simple substitution of one known element for another to obtain predictable results, the use of a known technique to improve similar devices in the same way, the application of a known technique to a known device ready for improvement to yield a predictable result, and obvious to try.

To the extent Perez is deemed to not expressly or inherently disclose “the proximity sensor is a mechanical proximity sensor, an optical sensor, or a range-detecting sensor,” it would be obvious to combine the disclosure of Perez with those of Numazawa as described in the Numazawa claim chart, which is incorporated herein in its entirety by reference. Perez and Numazawa are both directed to conserving battery power in mobile stations generally and more particularly at conserving battery power in mobile

stations by using sensors to detect when the user of the mobile station is in a call and unlikely to be looking at the display (as when, for example, the proximity sensor detects the user's ear by the mobile station) and to power off the display of mobile stations at such times. Perez at ¶ 0013 (“Referring to FIG. 1, a portable communication product 10 such as a cellular phone includes a transmitter radio having a microphone 20, an earpiece 22, a keypad 18 and a display 12 (such as a color display) coupled to the transmitter radio. The portable communication product 10 further includes at least one sensor (24, 26, 28 or 30) and a processor 16. The sensor can be used for detecting a user condition of the portable communication device such as a talk condition when the user is assumed to be talking on the portable communication device. The processor 16 can be programmed to at least reduce power provided to the display 12 when the sensor detects the talk condition. The processor 16 can also turn off power to the display 12 during a talk condition if desired.”); Numazawa at ¶ Abstract (“To achieve reduced power consumption through stopping operation of unnecessary functions during use of a wireless terminal. A CPU 2 identifies start of a call state through a signal from a signal processing portion 3 for controlling communication with a base station, and identifies, through an output signal from detecting means 6, whether or not a user ear is in contact with a terminal. Upon identification of contact of the ear to the terminal, controlling means 8 are caused to stop the supply of electric power, from a power supply 7, to displaying means 9 for providing information to a user, and lighting means 10, such as a black light.”), ¶ 0005-0007 (“In the present invention, control is such that, upon determination that the wireless terminal is in a call, operation of functions believe be unnecessary, due to the user of the terminal being in a call, is stopped, and upon termination of the call, operation of the stopped functions is restarted. Additionally, because it is envisioned that there will also be cases where, even during a call, the face of the user may be separated from the receiver of the terminal, control is performed so as to enable restarting of the operations of the functions that had been stopped as unnecessary, through detecting whether or not the user of the terminal has the receiver in contact with an ear. The achievement of reduced power consumption through stopping operation of functions that become unnecessary in use of the terminal, as described above, can be anticipated to have the effect of extending the life of the power supply, such as a battery.”) A person of ordinary skill in the art at the time of the alleged invention would be motivated to modify Perez to have “the proximity sensor is a mechanical proximity sensor, an optical sensor, or a range-detecting sensor,” as disclosed in Numazawa for a number of different reasons, including that it would support Perez’s ability to conserve battery power in mobile stations, and doing so would be within the knowledge and ability of a person of ordinary skill in the art at the time of the alleged invention. The combination would constitute, at least, combining prior art elements according to known methods to yield predictable results, a simple substitution of one known element for another to obtain predictable

	<p>results, the use of a known technique to improve similar devices in the same way, the application of a known technique to a known device ready for improvement to yield a predictable result, and obvious to try.</p>
<p>[Claim 6] The mobile station as recited in claim 1, wherein the proximity sensor is located proximate to the display.</p>	<p>Perez discloses that the proximity sensor is located proximate to the display.</p> <p>For example:</p> <p>“Referring to FIG. 1, a portable communication product 10 such as a cellular phone includes a transceiver radio having a microphone 20, an earpiece 22, a keypad 18 and a display 12 (such as a color display) coupled to the transceiver radio. The portable communication product 10 further includes at least one sensor (24, 26, 28 or 30) and a processor 16. The sensor can be used for detecting a user condition of the portable communication device such as a talk condition when the user is assumed to be talking on the portable communication device. The processor 16 can be programmed to at least reduce power provided to the display 12 when the sensor detects the talk condition. The processor 16 can also turn off power to the display 12 during a talk condition if desired.” Perez at [0013].</p>

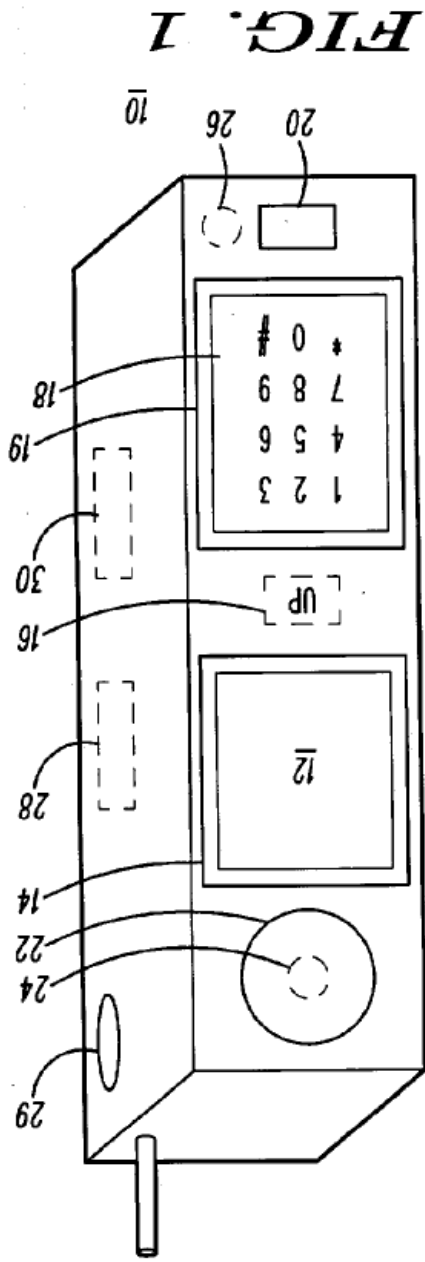

Perez at Fig. 1.

To the extent Seo is deemed to not expressly disclose “the proximity sensor is located proximate to the display,” Perez inherently discloses this limitation. Perez discloses that its invention cuts power to the display during a call when the user has the receiver against his or her ear because the display is an unnecessary function at this time, i.e., it is not visible. A person of ordinary skill in the art at the time of the alleged invention would understand that the display is not visible because the user’s head is against it and, if the detecting means is to detect this, it should be “located proximate to the display.” Thus, a person of ordinary skill in the art at the time of the alleged invention would understand Perez to inherently disclose that “the proximity sensor is located proximate to the display.”

To the extent Perez is deemed to not expressly or inherently disclose “the proximity sensor is located proximate to the display,” Perez renders it obvious to one of skill in the art to have “the proximity sensor . . . located proximate to the display.” It would be obvious to a person of ordinary skill in the art at the time of

the alleged invention that “the proximity sensor is located proximate to the display” because, in this location, it can determine that the display is not visible because the user’s head is against it. This would constitute, at least, combining prior art elements according to known methods to yield predictable results, a simple substitution of one known element for another to obtain predictable results, the use of a known technique to improve similar devices in the same way, the application of a known technique to a known device ready for improvement to yield a predictable result, and obvious to try.

To the extent Perez is deemed to not expressly or inherently disclose “the proximity sensor is located proximate to the display,” it would be obvious to combine the disclosure of Perez with those of Fukiharu 598 as described in the Fukiharu 598 claim chart, which is incorporated herein in its entirety by reference. Perez and Fukiharu 598 are both directed to conserving battery power in mobile stations generally and more particularly at conserving battery power in mobile stations by using sensors to detect when the user of the mobile station is in a call and unlikely to be looking at the display (as when, for example, the proximity sensor detects the user’s ear by the mobile station) and to power off the display of mobile stations at such times. Perez at ¶ 0013 (“Referring to FIG. 1, a portable communication product 10 such as a cellular phone includes a transceiver radio having a microphone 20, an earpiece 22, a keypad 18 and a display 12 (such as a color display) coupled to the transceiver radio. The portable communication product 10 further includes at least one sensor (24, 26, 28 or 30) and a processor 16. The sensor can be used for detecting a user condition of the portable communication device such as a talk condition when the user is assumed to be talking on the portable communication device. The processor 16 can be programmed to at least reduce power provided to the display 12 when the sensor detects the talk condition. The processor 16 can also turn off power to the display 12 during a talk condition if desired.”); Fukiharu 598 at ¶ 0018 (“The present invention, through the use of a structure as described above, enables a reduction in the consumption of battery power, through enabling the lighting devices to be turned OFF when the ear is caused to contact the receiver portion in order to hear the receiver sound during voice communications of a mobile telephone when the lighting devices (backlights) for a liquid crystal display device and keypad portion of a mobile telephone are lit, such as that night.”). A person of ordinary skill in the art at the time of the alleged invention would be motivated to modify Perez to have “the proximity sensor is located proximate to the display” as disclosed in Fukiharu 598 to determine that the display is not visible because the user’s head is against it. The combination would constitute, at least, combining prior art elements according to known methods to yield predictable results, a simple substitution of one known element for another to obtain predictable results, the use of a known

technique to improve similar devices in the same way, the application of a known technique to a known device ready for improvement to yield a predictable result, and obvious to try.

To the extent Perez is deemed to not expressly or inherently disclose “the proximity sensor is located proximate to the display,” it would be obvious to combine the disclosure of Perez with those of Numazawa as described in the Numazawa claim chart, which is incorporated herein in its entirety by reference. Perez and Numazawa are both directed to conserving battery power in mobile stations generally and more particularly at conserving battery power in mobile stations by using sensors to detect when the user of the mobile station is in a call and unlikely to be looking at the display (as when, for example, the proximity sensor detects the user’s ear by the mobile station) and to power off the display of mobile stations at such times. Perez at ¶ 0013 (“Referring to FIG. 1, a portable communication product 10 such as a cellular phone includes a transceiver radio having a microphone 20, an earpiece 22, a keypad 18 and a display 12 (such as a color display) coupled to the transceiver radio. The portable communication product 10 further includes at least one sensor (24, 26, 28 or 30) and a processor 16. The sensor can be used for detecting a user condition of the portable communication device such as a talk condition when the user is assumed to be talking on the portable communication device. The processor 16 can be programmed to at least reduce power provided to the display 12 when the sensor detects the talk condition. The processor 16 can also turn off power to the display 12 during a talk condition if desired.”); Numazawa at ¶ Abstract (“To achieve reduced power consumption through stopping operation of unnecessary functions during use of a wireless terminal. A CPU 2 identifies start of a call state through a signal from a signal processing portion 3 for controlling communication with a base station, and identifies, through an output signal from detecting means 6, whether or not a user ear is in contact with a terminal. Upon identification of contact of the ear to the terminal, controlling means 8 are caused to stop the supply of electric power, from a power supply 7, to displaying means 9 for providing information to a user, and lighting means 10, such as a black light.”), ¶ 0005-0007 (“In the present invention, control is such that, upon determination that the wireless terminal is in a call, operation of functions believe be unnecessary, due to the user of the terminal being in a call, is stopped, and upon termination of the call, operation of the stopped functions is restarted. Additionally, because it is envisioned that there will also be cases where, even during a call, the face of the user may be separated from the receiver of the terminal, control is performed so as to enable restarting of the operations of the functions that had been stopped as unnecessary, through detecting whether or not the user of the terminal has the receiver in contact with an ear. The achievement of reduced power consumption through stopping operation of functions that become unnecessary in use of the terminal, as described above, can be

	<p>anticipated to have the effect of extending the life of the power supply, such as a battery.’’). A person of ordinary skill in the art at the time of the alleged invention would be motivated to modify Perez to have “the proximity sensor is located proximate to the display” as disclosed in Numazawa to determine that the display is not visible because the user’s head is against it. The combination would constitute, at least, combining prior art elements according to known methods to yield predictable results, a simple substitution of one known element for another to obtain predictable results, the use of a known technique to improve similar devices in the same way, the application of a known technique to a known device ready for improvement to yield a predictable result, and obvious to try.</p>
<p>[Claim 8 – Preamble] 8. A method of conserving battery power in a mobile station, comprising:</p>	<p>To the extent the preamble is construed as limiting, Perez discloses a method of conserving battery power in a mobile station:</p> <p>For example: <i>see</i> discussion of claim 1, <i>supra</i>, which is incorporated herein by reference.</p>
<p>[8a] detecting whether an external object is proximate;</p>	<p>Perez discloses detecting whether an external object is proximate.</p> <p>For example: <i>see</i> discussion of claim element [1b], <i>supra</i>, which is incorporated herein by reference.</p> <p>To the extent Perez is deemed to not expressly or inherently disclose this claim element, Perez renders this claim element obvious to a person of skill in the art. <i>See</i> discussion of claim element [1b], <i>supra</i>, which is incorporated herein by reference.</p>
<p>[8b] determining whether a telephone call is active; and</p>	<p>Perez discloses determining whether a telephone call is active.</p> <p>For example: <i>see</i> discussion of claim element [1d], <i>supra</i>, which is incorporated herein by reference.</p>

<p>[8c] reducing power consumption of a display of the mobile station if (i) a telephone call is determined to be active and (ii) the proximity of the external object is detected; wherein:</p>	<p>Perez discloses reducing power consumption of a display of the mobile station if (i) a telephone call is determined to be active and (ii) the proximity of the external object is detected.</p> <p>For example: <i>see</i> discussion of claim elements [1f], [1h], <i>supra</i>, which are incorporated herein by reference.</p> <p>To the extent Perez is deemed to not expressly disclose this claim limitation, Perez inherently discloses this limitation. <i>See</i> discussion of claim element [1h], which is incorporated herein by reference.</p> <p>To the extent Perez is deemed to not expressly or inherently disclose this claim limitation, Perez renders it obvious to one of skill in the art at the time of the alleged invention. <i>See</i> discussion of claim element [1h], <i>supra</i>, which is incorporated herein by reference.</p> <p>To the extent Perez is deemed to not expressly or inherently disclose this claim element, it would be obvious to combine the disclosure of Perez with those of Fukiharu 598 as described in the Fukiharu 598 claim chart, which is incorporated herein in its entirety by reference. See discussion of claim element [1h], <i>supra</i>, which is incorporated herein by reference.</p> <p>To the extent Perez is deemed to not expressly or inherently disclose this claim element, it would be obvious to combine the disclosure of Perez with those of Numazawa as described in the Numazawa claim chart, which is incorporated herein in its entirety by reference. <i>See</i> discussion of claim element [1h], <i>supra</i>, which is incorporated herein by reference.</p> <p>To the extent Perez is deemed to not expressly or inherently disclose this claim element, it would be obvious to combine the disclosure of Perez with those of Miyashita as described in the Miyashita claim chart, which is incorporated herein in its entirety by reference. <i>See</i> discussion of claim element [1h], <i>supra</i>, which is incorporated herein by reference.</p>
<p>[8d] the telephone call is a wireless telephone call;</p>	<p>Perez discloses that the telephone call is a wireless telephone call.</p> <p>For example: <i>see</i> discussion of claim element [1g], <i>supra</i>, which is incorporated herein by reference.</p>

<p>[8e] the power consumption of the display is reduced while the proximity of the external object is detected only if the wireless telephone call is determined to be active; and</p>	<p>Perez discloses that the power consumption of the display is reduced while the proximity of the external object is detected only if the wireless telephone call is determined to be active.</p> <p>For example: <i>see</i> discussion of claim element [1f], <i>supra</i>, which is incorporated herein by reference.</p> <p>To the extent Perez is deemed to not expressly or inherently disclose this claim element, Perez renders this claim element obvious to a person of skill in the art. <i>See</i> discussion of claim element [1f], <i>supra</i>, which is incorporated herein by reference.</p>
<p>[8f] detecting whether an external object is proximate begins substantially concurrently with the mobile station initiating an outgoing wireless telephone call or receiving an incoming wireless telephone call.</p>	<p>Perez discloses that detecting whether an external object is proximate begins substantially concurrently with the mobile station initiating an outgoing wireless telephone call or receiving an incoming wireless telephone call.</p> <p>For example: <i>see</i> discussion of claim element [1i], <i>supra</i>, which is incorporated herein by reference.</p> <p>To the extent Perez is deemed to not expressly disclose this claim limitation, Perez inherently discloses this limitation. <i>See</i> discussion of claim element [1i], <i>supra</i>, which is incorporated herein by reference.</p> <p>To the extent Perez is deemed to not expressly or inherently disclose this claim limitation, Perez renders it obvious to one of skill in the art at the time of the alleged invention. <i>See</i> discussion of claim element [1i], <i>supra</i>, which is incorporated herein by reference.</p> <p>To the extent Perez is deemed to not expressly or inherently disclose this claim element, it would be obvious to combine the disclosure of Perez with those of Fukiharu 598 as described in the Fukiharu 598 claim chart, which is incorporated herein in its entirety by reference. <i>See</i> discussion of claim element [1i], <i>supra</i>, which is incorporated herein by reference.</p> <p>To the extent Perez is deemed to not expressly or inherently disclose this claim element, it would be obvious to combine the disclosure of Perez with those of Numazawa as described in the Numazawa claim chart, which is incorporated herein in its entirety by reference. <i>See</i> discussion of claim element [1i], <i>supra</i>, which is incorporated herein by reference.</p>

	<p>To the extent Perez is deemed to not expressly or inherently disclose this claim element, it would be obvious to combine the disclosure of Perez with those of Miyashita as described in the Miyashita claim chart, which is incorporated herein in its entirety by reference. <i>See</i> discussion of claim element [1i], <i>supra</i>, which is incorporated herein by reference.</p>
<p>[Claim 12] The method as recited in claim 8, wherein the detecting of the proximity of the external object is performed by a mechanical proximity sensor, an optical sensor, or a range-detecting sensor.</p>	<p>Perez discloses that the detecting of the proximity of the external object is performed by a mechanical proximity sensor, an optical sensor, or a range-detecting sensor.</p> <p>For example: <i>see</i> discussion of claim 5, <i>supra</i>, which is incorporated herein by reference.</p> <p>To the extent Perez is deemed to not expressly disclose this claim limitation, Perez inherently discloses this limitation. <i>See</i> discussion of claim 5, <i>supra</i>, which is incorporated herein by reference.</p> <p>To the extent Perez is deemed to not expressly or inherently disclose this claim limitation, Perez renders it obvious to one of skill in the art at the time of the alleged invention. <i>See</i> discussion of claim 5, <i>supra</i>, which is incorporated herein by reference.</p> <p>To the extent Perez is deemed to not expressly or inherently disclose this claim element, it would be obvious to combine the disclosure of Perez with those of Fukiharu 598 as described in the Fukiharu 598 claim chart, which is incorporated herein in its entirety by reference. <i>See</i> discussion of claim element [1h], <i>supra</i>, which is incorporated herein by reference.</p> <p>To the extent Perez is deemed to not expressly or inherently disclose this claim element, it would be obvious to combine the disclosure of Perez with those of Numazawa as described in the Numazawa claim chart, which is incorporated herein in its entirety by reference. <i>See</i> discussion of claim 5, <i>supra</i>, which is incorporated herein by reference.</p>

Exhibit A6

**Exhibit A6 - Mantyjärvi
to Defendants' Preliminary Invalidation Contentions**

**Invalidation Chart for U.S. Patent No. 7,319,889
U.K. Patent Application No. 2,357,400 ("Mantyjärvi")**

U.K. Patent Application No. 2,357,400 to Mantyjärvi *et al.* ("Mantyjärvi") was filed on December 17, 1999 and published on June 20, 2001. Mantyjärvi is prior art to the '889 Patent under at least pre-AIA §§ 102(b), 102(e). Mantyjärvi anticipates or renders obvious, alone or in combination with other prior art references, each of the Asserted Claims of the '889 Patent as described in the chart below and in the main invalidity contentions document to which this chart is annexed.

It would have been obvious under 35 U.S.C. § 103 to a person having ordinary skill in the art at the time of the alleged invention to combine the teachings of Mantyjärvi with the following references:

1. Japanese Unexamined Patent Application Publication No. 2000-106598 to Fukiharu ("Fukiharu 598"). Fukiharu 598 qualifies as prior art under at least pre-AIA §§ 102(a), 102(b), and 102(e). Fukiharu 598 was published on April 11, 2000.

<u>Asserted Claims</u>	<u>Corresponding Disclosure in the Prior Art Reference(s)</u>
[Claim 1 – Preamble] 1. A mobile station, comprising:	<p>Mantyjärvi discloses a mobile station.</p> <p>For example: "In a communication system a terminal is used for providing a user interface for the user of the communication system. In other words, by means of the terminal the user may access and communicate over the communication system.</p> <p>An example of the terminal is a mobile station that may be used in a radio communication system. The mobile station is typically a portable hand-held device that provides, in cooperation with the radio communication system, mobility for the user. When the mobile station is not in use, it is usually positioned in the user's pocket or in a special case or similar. The mobile station typically comprises a keypad for controlling the operation thereof, such as for dialing in a desired telephone number and for controlling</p>

various functions of the mobile station. A mobile station is also typically provided with a display. The display may be used for showing various information to the user of the mobile station. Instead of being an entirely hand-held unit, a mobile station may also comprise separate units, such as a base transceiver unit and a separate handset portion and/or a separate headset portion.” Mantyjärvi at 1:10-29.

“For example, a mobile station may be provided with a keyboard lock referred to above. The basic idea of the keypad or keyboard lock is to prevent the user to mistakenly press any of the keys when this is not desired (e.g. when the mobile station is in the pocket of the user). For example, by means of the lock it is possible to prevent an accidental call establishment to a telephone number that is not actually selected. The keyboard lock may be controlled in alternative ways. According to one possibility predefined keys of the keypad can be used for locking and unlocking the keypad of the mobile station.” Mantyjärvi at 3:4-15.

“Figure 1 shows a mobile station in accordance with an embodiment of the present invention. The mobile station 1 comprises a housing or cover portion 11 which protects and encapsulates the various internal components of the mobile station. The internal components are not shown in greater detail, but may typically comprise components such as a processor 12 that is for controlling one or several functions of the mobile station.” Mantyjärvi at 6:10-16.

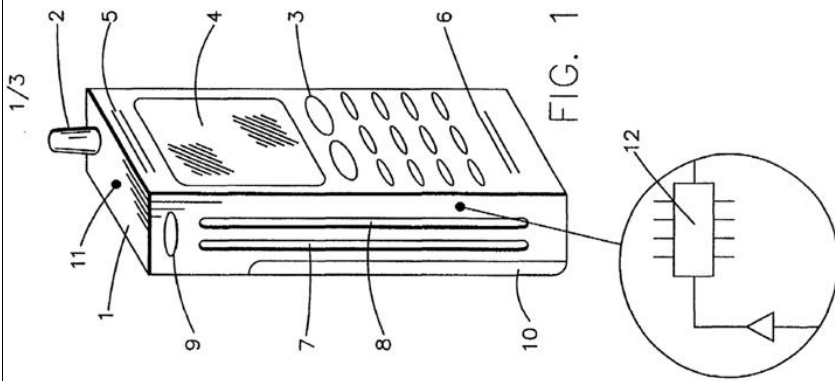

Mantjarvi at Fig. 1.

“26. A terminal according to any of the preceding claims, wherein the terminal comprises a mobile station of a radio communication system.” Mantjarvi at Claim 26.

[1a] a display;

Mantjarvi discloses a display.

For example:

“A mobile station is also typically provided with a display. The display may be used for showing various information to the user of the mobile station. Instead of being an entirely hand-held unit, a mobile station may also comprise separate units, such as a base transceiver unit and a separate handset portion and/or a separate headset portion.”
Mantyjärvi at 1:24-29.

“Similarly, any other functions of the terminal may be controlled by pressing appropriate keys or moving one or several components of the terminal to operate an associated switch. The functions and/or operations that need to be controlled may be functions such as switching the terminal between different modes of operation, controlling a keyboard lock or display of the terminal, switching on/off the lighting of the keyboard or the display, or controlling any other special features of the terminal or services provided for the user of the terminal (such as voice mail, short text messages, calendar or alarm functions and so on).” Mantyjärvi at 2:25-3:2.

“The mobile station 1 comprises also a display 4. The display may be used for displaying various messages and information to the user. The user may also use the display for the control operations of the mobile station, e.g. such that the user uses the keys 3 for the selection of an appropriate function from a menu displayed to him by the display 4.”
Mantyjärvi at 7:4-9.

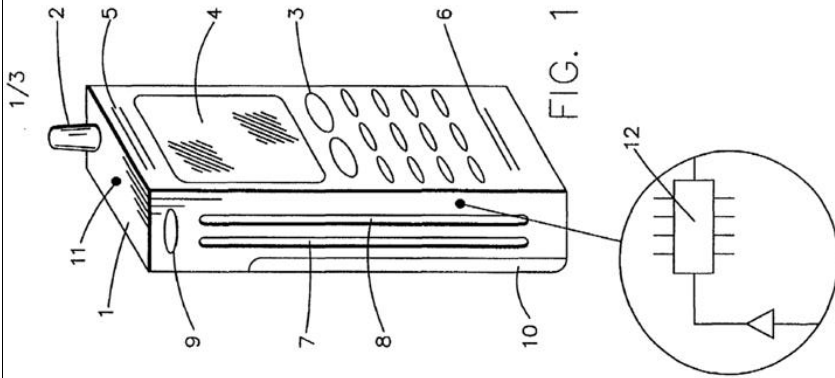

Mantjarvi at Fig. 1.

“A terminal according to any of the preceding claims, wherein the operation of a display of the terminal is controlled based on the signal from the detector means.” Mantjarvi at Claim 8.

[1b] a proximity sensor adapted to generate a signal indicative of proximity of an external object; and

Mantjarvi discloses a proximity sensor adapted to generate a signal indicative of proximity of an external object.

For example:

“According to one aspect of the present invention, there is provided a terminal for a communication system, the terminal comprising detector means that are arranged to detect a contact between at least one surface of the terminal and the skin of the user of the terminal, wherein at least one function of the terminal is controlled based on a signal from the detecting means.

The detector means may comprise a first detector arrangement and a second detector arrangement, wherein said first and second detector arrangements are based on different principles of detecting a contact between the terminal and the skin of the user. The control of the terminal that is based on the signal from the detector means is preferably provided only if said first and second detector arrangements both output a signal that indicates a contact between the terminal and the skin of the user.

According to one aspect of the present invention, there is provided a detector arrangement for a terminal of a communication system, the terminal comprising at least one element that is to be held against the skin of the user of the terminal, the detector arrangement comprising circuitry for generating an output signal whenever a surface of the terminal touches in a predefined manner the skin of the user, wherein the output signal is arranged to be employed in the control of at least one function of the terminal.

According to another aspect of the present invention, there is provided a method for providing control of at least one function of a terminal of a communication system, comprising the steps of:

detecting a contact between a surface of the terminal and the skin of the user of the terminal; generating an output signal indicating a contact between the surface of the terminal and the skin of the user; and controlling said at least one function of the terminal based on the output signal.” Mantjarvi at 4:4-5:10.

“Two strip electrodes 7 and 8 are attached on one side of the station 1. The electrodes 7 and 8 are employed for detecting a contact between the skin of the user and the mobile station. According to a possibility the electrodes 7 and 8 are attached on the outer surface of the housing 11 of the mobile station 1. The electrodes may also be embedded in the

cover material such that the surface of the electrodes will remain visible and may thus be touched by the skin of the user.

More particularly, the electrodes 7 and 8 may be arranged to measure so called galvanic skin response (GSR). Figure 2 discloses a block diagram for circuitry that may be used when implementing a galvanic skin response touch sensing arrangement 20. The first electrode 7 is coupled to a voltage source V_{cc} via a line 27. The voltage V_{cc} may equal the operational voltage of the mobile station, but V_{cc} may also be different from that. Voltage V_{cc} is preferably provided by the battery 10 of the mobile station 1. A buffer 21 and an appropriate impedance 24 8 may be provided for scaling the current and voltage on the line 27 between the electrode 7 and the voltage source V_{cc} . The second electrode 8 is coupled to an output 26 of the circuitry 20. The signal from the electrode 8 may be amplified by an amplifier 23 before the signal is output from the circuitry 20. The amplifier circuit may comprise a resistor/ impedance 25.

The galvanic skin response (GSR) detection method is based on provision of a conductive path between two or more electrodes. When the user grips the mobile station 1 by his hand (not shown), the skin of the hand will provide the conductive path between the electrodes 7 and 8 of Figures 1 and 2. Now, when a conductive path is provided between the electrodes 7 and 8, the voltage and current at the output line 26 will change in accordance with known principles. The GSR sensing arrangement 20 gives typically so-called TTL level (transistor to transistor logic level) output signal when the conductive material is in touch with at last two of the electrodes. A component 22 may be used for setting an appropriate threshold level for the conductivity, i.e. the component 22 may trigger the circuitry 20 to output a signal that indicates a contact between the hand of the user and the mobile station 1.” Mäntyjärvi at 7:14-8:22.

“As illustrated by the flow chart of figure 6, the output signal on line 26 may be used in the control of a function of the mobile station. For example, activation of a mobile station that is in a standby mode may be based on the output signal from the sensing arrangement. The activation of the mobile station may be triggered by the control unit 12 of the mobile station based on a received TTL level signal output 26 from the GSR arrangement 20. The station may be correspondingly deactivated i.e. returned 9 to the

standby mode after the control unit no longer receives the TTL level signal. An automated keyboard lock may function in a corresponding manner, i.e. the keyboard may be unlocked only when the GSR detecting arrangement outputs a TTL level signal.

The station may also be switched between different modes of operation or even on and off based on the output signal received from the detecting means. The lighting of the keypad and/or the display may be controlled based on this information. According to an example, a vibrating alarm arrangement of the mobile station is controlled such that no sound alarm is provided when the mobile station is detected to be in contact with the skin of the user, while a sound alarm will be provided when the mobile station (or any part or accessory thereof) is not in direct contact with the skin of the user. It is to be noted that the above functions described in the context of a mobile station are only examples and that the embodiments of the present invention may be employed when controlling any function of a communications terminal. It is also noted that the output signal from the detector arrangement may indicate a "positive" or "negative" contact. In other words, a signal may be outputted only when the terminal is in contact with the skin of the user or alternatively only when there is no contact between the user and the terminal." Mäntyjärvi at 8:24-9:24.

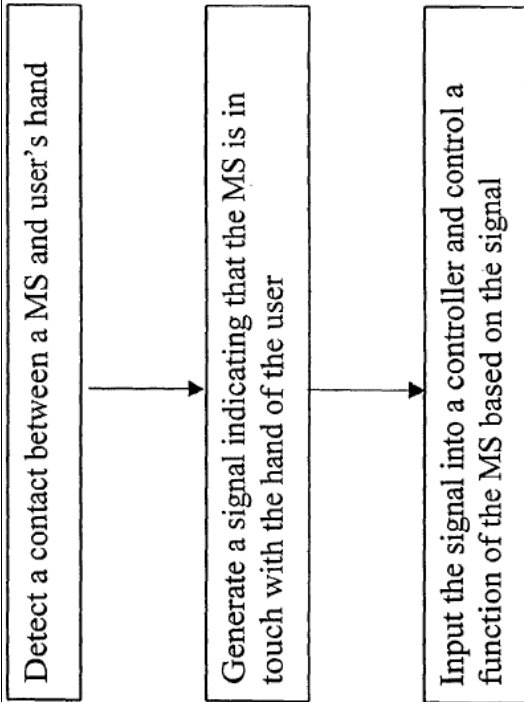

FIG. 6

Mantjarvi at Fig. 6.

“Another possibility for measuring the presence of the living tissue in touch or in close proximity with the terminal is so called capacitive proximity (CP) sensor. The capacitive proximity sensor requires only one electrode, even though it is possible to use several CP sensors. The CP based system can be adjusted to sense the proximity of the living tissue, for example such that a CP sensing arrangement will react when the distance between the skin of the user and the mobile station is within a range of 0 to 5 mm. The capacitive proximity sensors may be arranged to be sensitive only for living tissue, and will thus not react to other materials. When the capacitive proximity sensor senses a living tissue, it may output an appropriate signal, such as a TTL level signal. The use of the TTL level output signal in accordance with the invention was already discussed above.

Figure 4 shows a schematic block diagram for a detection circuitry 31 based on the capacitive proximity sensor detection. In general, the circuitry 31 can be defined as

oscillating circuitry that is implemented by means of a flip-flop switch 32. The circuitry 31 is provided with suitable triggering means 33, such as a Schmitt trigger. An inverting amplifier 34 may also be provided on the output line 35. The circuitry operates such that when the capacitive sensor 30 is touched by a living tissue, the output on line 35 will rise in the Vcc level, thus providing a signal indicating that the terminal is in touch with living tissue.

The capacitive proximity sensor may also detect a living tissue, such as the skin of the user, that is not in an direct contact with the sensors. The skin may be, for example, within a distance that is up to 5 mm from the sensing electrode. Therefore the capacitive proximity electrode 30 may be placed on the internal surface of the cover material of the terminal 1 or may be embedded within the cover material of the terminal 1. For example, it could be placed inside the cover of the battery 10 of the mobile terminal 1.” Mäntyjärvi at 10:20-11:25.

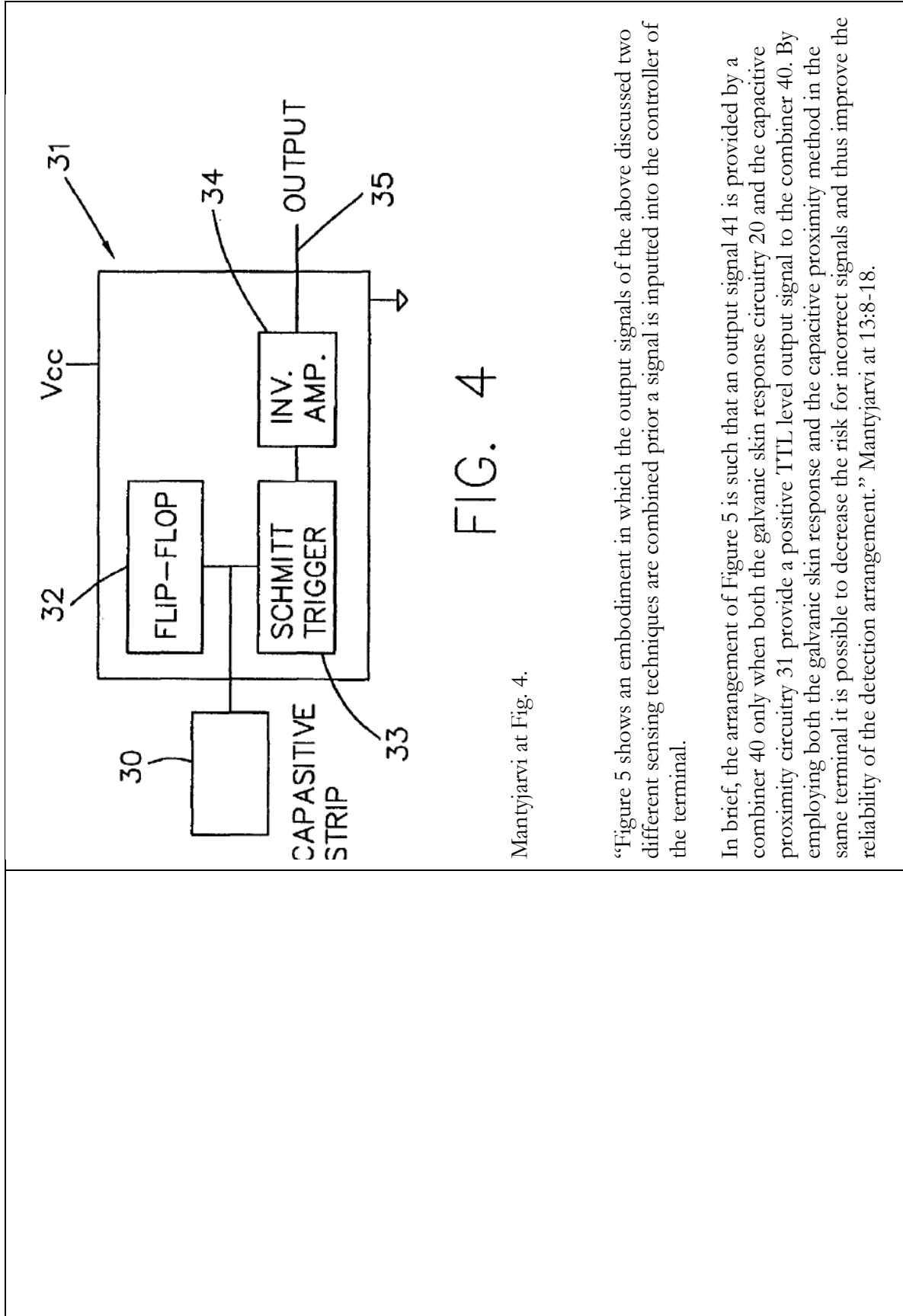
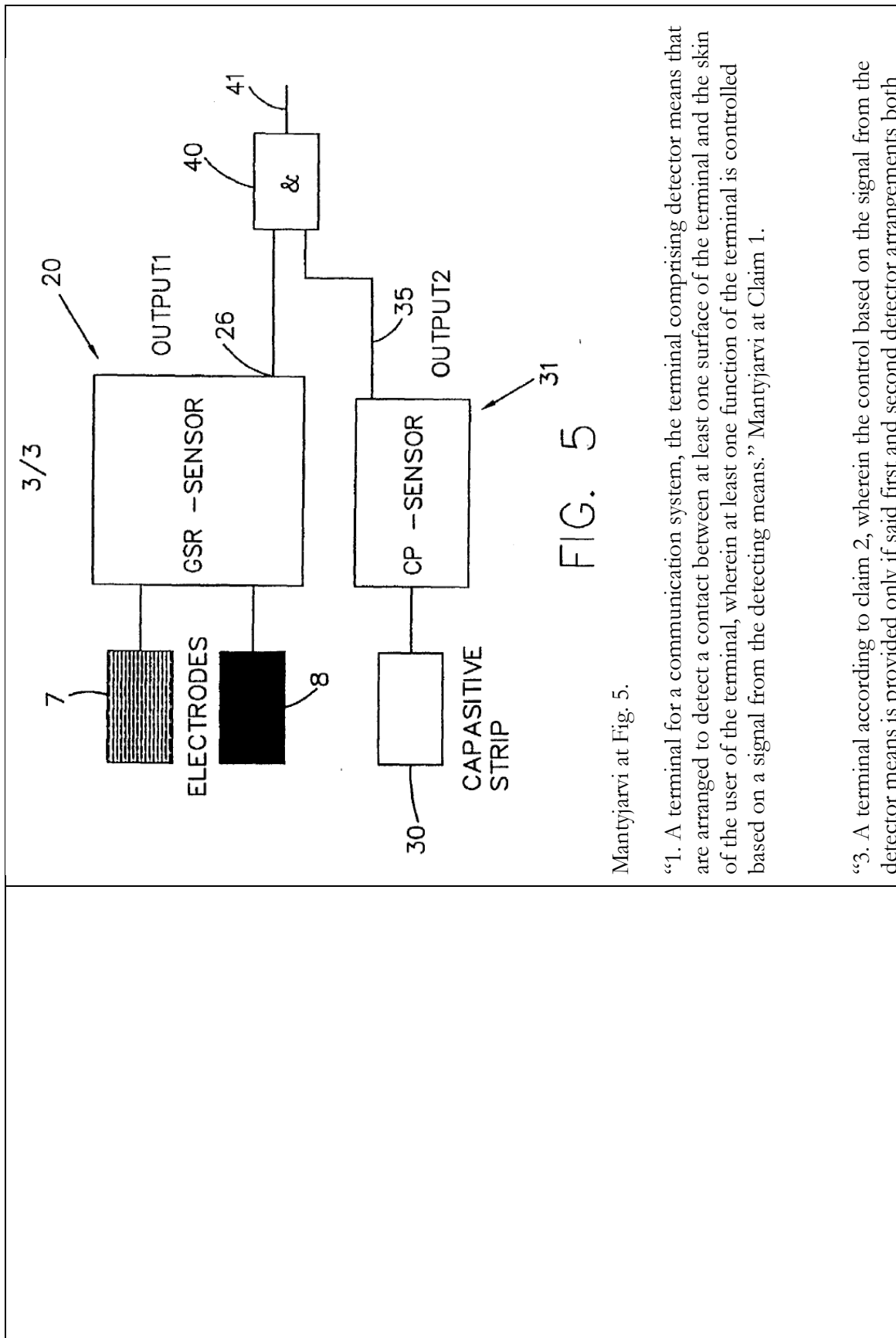

FIG. 4

Mantjarvi at Fig. 4.

“Figure 5 shows an embodiment in which the output signals of the above discussed two different sensing techniques are combined prior a signal is inputted into the controller of the terminal.

In brief, the arrangement of Figure 5 is such that an output signal 41 is provided by a combiner 40 only when both the galvanic skin response circuitry 20 and the capacitive proximity circuitry 31 provide a positive TTL level output signal to the combiner 40. By employing both the galvanic skin response and the capacitive proximity method in the same terminal it is possible to decrease the risk for incorrect signals and thus improve the reliability of the detection arrangement.” Mantjarvi at 13:8-18.



Mantjarvi at Fig. 5.

“1. A terminal for a communication system, the terminal comprising detector means that are arranged to detect a contact between at least one surface of the terminal and the skin of the user of the terminal, wherein at least one function of the terminal is controlled based on a signal from the detecting means.” Mantjarvi at Claim 1.

“3. A terminal according to claim 2, wherein the control based on the signal from the detector means is provided only if said first and second detector arrangements both

	<p>output a signal that indicates a contact between the terminal and the skin of the user.” Mantyjärvi at Claim 3.</p> <p>“16. A terminal according to any of the preceding claims, wherein the detector means comprise a capacitive proximity sensor.” Mantyjärvi at Claim 16.</p> <p>“27. A detector arrangement for a terminal of a communication system, the terminal comprising at least one element that is to be held against the skin of the user of the terminal, the detector arrangement comprising circuitry for generating an output signal whenever a surface of the terminal touches in a predefined manner the skin of the user, wherein the output signal is arranged to be employed in the control of at least one function of the terminal.” Mantyjärvi at Claim 27.</p>
<p>[1c] a microprocessor adapted to:</p>	<p>Mantyjärvi discloses a microprocessor.</p> <p>For example:</p> <p>“Figure 1 shows a mobile station in accordance with an embodiment of the present invention. The mobile station 1 comprises a housing or cover portion 11 which protects and encapsulates the various internal components of the mobile station. The internal components are not shown in greater detail, but may typically comprise components such as a processor 12 that is for controlling one or several functions of the mobile station.” Mantyjärvi at 6:10-16.</p>

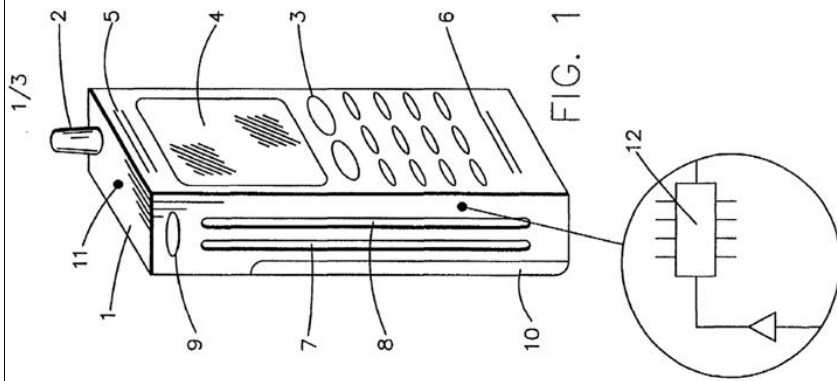

Mantjarvi at Fig. 1.

“As illustrated by the flow chart of figure 6, the output signal on line 26 may be used in the control of a function of the mobile station. For example, activation of a mobile station that is in a standby mode may be based on the output signal from the sensing arrangement. The activation of the mobile station may be triggered by the control unit 12 of the mobile station based on 30 a received TTL level signal output 26 from the GSR arrangement 20.” Mantjarvi at 8:24-31.

	<p>“In addition, the sensitivity of the control unit of the mobile station can be adjusted in accordance with specific requirements and/or conditions and may vary if the requirements and/or conditions change.” Mantjarvi at 14:13-16.</p>
<p>[1d] (a) determine whether a telephone call is active;</p>	<p>Mantjarvi discloses the microprocessor adapted to determine whether a telephone call is active.</p> <p>For example: “An example of the terminal is a mobile station that may be used in a radio communication system. The mobile station is typically a portable hand-held device that provides, in cooperation with the radio communication system, mobility for the user. When the mobile station is not in use, it is usually positioned in the user’s pocket or in a special case or similar. The mobile station typically comprises a keypad for controlling the operation thereof, such as for dialing in a desired telephone number and for controlling various functions of the mobile station.” Mantjarvi at 1:15-24.</p> <p>“The user typically controls the operation and/or functions of the terminal by pressing appropriate buttons on a keyboard of the terminal or by lifting the handset off-hook/placing the handset on-hook or opening/closing a specific cover connected to a switch and so on. Voice activated control systems are also known. For example, when the user wishes to establish a call, he usually selects or fetches the desired destination number by pressing appropriate keys on the keyboard or he may use possible voice activation functions of the terminal. When the user receives a call, the call is typically answered by lifting the handset off-hook, or by pressing at least one key of the key board or by opening the special cover of the keyboard.</p> <p>Similarly, any other functions of the terminal may be controlled by pressing appropriate keys or moving one or several components of the terminal to operate an associated</p>

switch. The functions and/or operations that need to be controlled may be functions such as switching the terminal between different modes of operation, controlling a keyboard lock or display of the terminal, switching on/off the lighting of the keyboard or the display, or controlling any other special features of the terminal or services provided for the user of the terminal (such as voice mail, short text messages, calendar or alarm functions and so on).

For example, a mobile station may be provided with a keyboard lock referred to above. The basic idea of the keypad or keyboard lock is to prevent the user to mistakenly press any of the keys when this is not desired (e.g. when the mobile station is in the pocket of the user). For example, by means of the lock it is possible to prevent an accidental call establishment to a telephone number that is not actually selected. The keyboard lock may be controlled in alternative ways. According to one possibility predefined keys of the keypad can be used for locking and unlocking the keypad of the mobile station.”
Mantyjärvi at 2:11-3:15.

“Figure 1 shows a mobile station in accordance with an embodiment of the present invention. The mobile station 1 comprises a housing or cover portion 11 which protects and encapsulates the various internal components of the mobile station. The internal components are not shown in greater detail, but may typically comprise components such as a processor 12 that is for controlling one or several functions of the mobile station.

The mobile station 1 also comprises transceiver means (not shown) for receiving and transmitting a radio signal through an antenna 2, possible circuit boards, lightning components and other internal components known in the art. The cover or housing 11 is usually of plastic material, but other materials may also be used.

The terminal 1 comprises further a keypad 3. The keypad typically comprises several buttons such as "on-hook" and "off hook" keys (sometimes referred to as "yes" and "no" keys) and keys for numerals from zero to nine. The keys can also be used for typing in alphabetic characters, such as for typing in short text messages and inputting names and numbers into a telephone number memory and/or entries into diaries or other special 7

functions provided by the mobile terminal. The mobile station 1 may also comprise a separate power switch 9." Mantjarvi at 6:10-22.

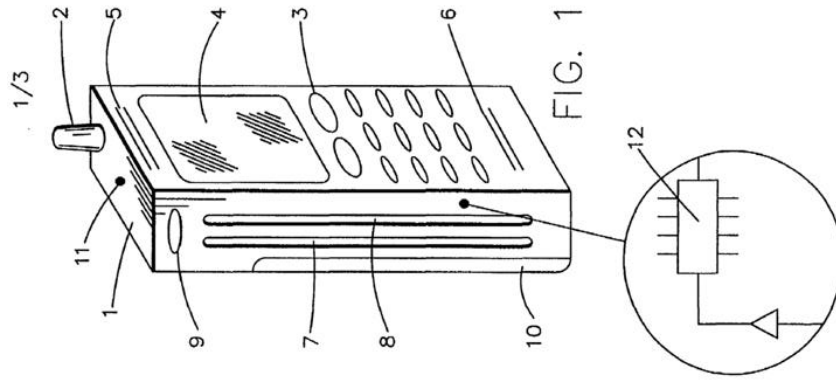

Mantjarvi at Fig. 1.

"The controller may provide different instructions for the controlled functions depending on the location or the context where the control is provided. For example, during

a normal speech call the lighting of the display and/or keyboard may be switched off after a predefined time has lapsed from the activation thereof. However, the lighting will stay on if the connection was established for data communication, such as for a wireless application protocol (WAP) connection or for an Internet connection.” Mantyjärvi at 14:21-30.

“Therefore a verification of the detection result of a detection arrangement may be desirable in some applications. The verification can be provided by employing more than one sensing technique in the generation of the output signal to make sure that the terminal is indeed in the hand of the user or against the cheek or ear of the user.” Mantyjärvi at 13:2-6.

“4. A terminal according to any of the preceding claims comprising a controller for controlling said at least one function of the terminal.” Mantyjärvi at Claim 4.

“5. A terminal according to any of the preceding claims, wherein switching between different modes of operation of the terminal is arranged to be triggered based on the signal from the detector means.” Mantyjärvi at Claim 5.

“24. A terminal according to any of the preceding claims, wherein the control of the function is based, in addition to the signal from the detector means, on at least one of the following: the operational status of the terminal; the location of the terminal; the time of the day; the time of the year; temperature; the type of the communication.” Mantyjärvi at Claim 24.

“26. A terminal according to any of the preceding claims, wherein the terminal comprises a mobile station of a radio communication system.” Mantyjärvi at Claim 26.

“31. A method according to claim 30, wherein the generation of the output signal comprises further steps of:

receiving a first signal from a first detector arrangement; 21 receiving a second signal from a second detector arrangement that is different from the operation principles thereof from the first detector arrangement; verifying the first and second signals; and generating the output signal if said first and second signals indicate similar results of detection.” Mantyjärvi at Claim 31.

To the extent Mantyjärvi is deemed to not expressly disclose the microprocessor adapted to “determine whether a telephone call is active,” Mantyjärvi inherently discloses this limitation. In Mantyjärvi, “during a normal speech call the lighting of the display and/or keyboard may be switched off after a predefined time has lapsed from the activation thereof.” Mantyjärvi at 14:24-26. A person of ordinary skill in the art at the time of the alleged invention would understand that in order for the mobile station in Mantyjärvi to “switch[] off” the “lighting of the display” “during a normal speech call,” the mobile station would necessarily need to determine when a “normal speech call” is ongoing and therefore “whether a telephone call is active.” Mantyjärvi also discloses “a processor 12 that is for controlling one or several functions of the mobile station.” Mantyjärvi at 6:15-16. A person of ordinary skill in the art at the time of the alleged invention would understand that the processor 12 of Mantyjärvi would control the function of determining whether a “normal speech call” is ongoing. Therefore a person of ordinary skill in the art at the time of the alleged invention would understand Mantyjärvi to necessarily disclose a microprocessor adapted to “determine whether a telephone call is active.”

To the extent Mantjarvi is deemed to not expressly or inherently disclose the microprocessor adapted to “determine whether a telephone call is active,” Mantjarvi renders this limitation obvious to one of skill in the art to “determine whether a telephone call is active.” A person of skill in the art would understand that in order for the mobile station in Mantjarvi to “switch[] off” the “lighting of the display” “during a normal speech call,” the mobile station would need to determine when a “normal speech call” is ongoing and therefore “whether a telephone call is active.” A person of ordinary skill in the art at the time of the alleged invention would find it obvious to implement the microprocessor of Mantjarvi to determine whether a “normal speech call is ongoing.” Doing so would be a design choice driven by a number of different reasons, including that it would support Mantjarvi’s ability to conserve battery power in mobile stations. Doing so would further support Mantjarvi’s ability to provide means for “controlling of at least one function of a terminal of a communication system” (Mantjarvi at 1:5-6) where the “sensitivity of the control unit of the mobile station can be adjusted in accordance with specific requirements and/or conditions and may vary if the requirements and/or conditions change.” Mantjarvi at 14:13-16. Doing so would be within the knowledge and ability of a person of ordinary skill in the art at the time of the alleged invention. Doing so would also constitute, at least, combining prior art elements according to known methods to yield predictable results, a simple substitution of one known element for another to obtain predictable results, the use of a known technique to improve similar devices in the same way, the application of a known technique to a known device ready for improvement to yield a predictable result, and obvious to try.

To the extent Mantjarvi is deemed to not expressly or inherently disclose a microprocessor adapted to “determine whether a telephone call is active,” it would be obvious to combine the disclosure of Mantjarvi with those of Fukiharu 598 as described in the Fukiharu 598 claim chart, which is incorporated herein in its entirety by reference. Mantjarvi and Fukiharu 598 are both directed to controlling the functionality of mobile stations based in part on signals from a proximity sensor. *See, e.g.*, Mantjarvi at 3:30-4:2 (“It is an aim of the embodiments of the present invention to address one or several of the disadvantages of the prior art terminals and to provide a new type of solution for controlling one or several functions of a terminal.”); Fukiharu 598 at Abstract (“The

object of the present invention is to provide a mobile telephone with a lighting device, and a method for controlling said lighting device, with improved portability through reducing the weight and volume of the battery, and to enable a thorough increase in talk time and standby time, through controlling, through a touch sensor that is provided on a receiver portion surface of the mobile telephone, operation of a lighting device (backlight) of a liquid crystal display device and/or a key pad portion.”). More particularly both Mantiyarvi and Fukiharu 598 disclose turning off the display of a mobile station based on signals from a proximity sensor indicating that a user’s face or ear is in close proximity to the mobile station. *See, e.g.*, Mantiyarvi at Claim 1 (“A terminal for a communication system, the terminal comprising detector means that are arranged to detect a contact between at least one surface of the terminal and the skin of the user of the terminal, wherein at least one function of the terminal is controlled based on a signal from the detecting means.”), Mantiyarvi at Claim 8 (“A terminal according to any of the preceding claims, wherein the operation of a display of the terminal is controlled based on the signal from the detector means.”), Mantiyarvi at Claim 11 (“A terminal according to any of the preceding claims, wherein the detector means are arranged to sense a contact between the terminal and the cheek and/or ear of the user.”); Fukiharu 598 at ¶0015 (“At this time, the lighting-ON state is maintained if not in the voice communication mode. If in the voice communication mode, a touch sensor 2c is placed into an operating state by a signal from the controlling portion 2a, and constantly outputs a detection output to the controlling portion 2a. If the touch sensor 2c contacts a portion of the human body, such as an ear, a lighting-OFF signal is outputted to the lighting device ON/OFF circuit portion 2b from the controlling portion 2a through the ON output of the touch sensor 2c, and the power supplies to both the lighting device (backlight) 3a and the lighting device (backlight) 4a go to the OFF state, and this lighting-OFF state is maintained until the touch sensor 2c goes into a non-contact state.”). A person of ordinary skill in the art at the time of the alleged invention would therefore understand that both Mantiyarvi and Fukiharu 598 disclose ways of conserving battery power by shutting of the display of a mobile station at such times that the user of the mobile station is unlikely to be looking at the display (as indicted by at least a proximity sensor). A person of ordinary skill in the art at the time of the alleged invention would be therefore be motivated to modify Mantiyarvi to use a microprocessor adapted to “determine whether a telephone call is active,” as disclosed in Fukiharu 598 for a number of different reasons, including that it would support Mantiyarvi’s ability to conserve

	<p>battery power in mobile stations. Doing so would further support Mantiyarvi's ability to provide means for "controlling of at least one function of a terminal of a communication system" (Mantiyarvi at 1:5-6) where the "sensitivity of the control unit of the mobile station can be adjusted in accordance with specific requirements and/or conditions and may vary if the requirements and/or conditions change." Mantiyarvi at 14:13-16. Doing so would be within the knowledge and ability of a person of ordinary skill in the art at the time of the alleged invention. The combination would constitute, at least, combining prior art elements according to known methods to yield predictable results, a simple substitution of one known element for another to obtain predictable results, the use of a known technique to improve similar devices in the same way, the application of a known technique to a known device ready for improvement to yield a predictable result, and obvious to try.</p>
<p>[1e] (b) receive the signal from the proximity sensor; and</p>	<p>Mantiyarvi discloses the microprocessor adapted to receive the signal from the proximity sensor.</p> <p>For example:</p> <p>"The present invention relates to a terminal for a communication system. The terminal includes detector means 7, 8 that are arranged to detect a contact between at least one surface of the terminal and the skin of the user. At least one function of the terminal is arranged to be controlled based on a signal generated by the detecting means in response to the detection. The sensor may be resistive, sensing galvanic skin resistance across linear contacts 7, 8 or could be a capacitive proximity sensor, or may be pressure sensitive." Mantiyarvi at Abstract.</p> <p>"According to one aspect of the present invention, there is provided a terminal for a communication system, the terminal comprising detector means that are arranged to detect a contact between at least one surface of the terminal and the skin of the user of</p>

the terminal, wherein at least one function of the terminal is controlled based on a signal from the detecting means.

The detector means may comprise a first detector arrangement and a second detector arrangement, wherein said first and second detector arrangements are based on different principles of detecting a contact between the terminal and the skin of the user. The control of the terminal that is based on the signal from the detector means is preferably provided only if said first and second detector arrangements both output a signal that indicates a contact between the terminal and the skin of the user.

According to one aspect of the present invention, there is provided a detector arrangement for a terminal of a communication system, the terminal comprising at least one element that is to be held against the skin of the user of the terminal, the detector arrangement comprising circuitry for generating an output signal whenever a surface of the terminal touches in a predefined manner the skin of the user, wherein the output signal is arranged to be employed in the control of at least one function of the terminal.

According to another aspect of the present invention, there is provided a method for providing control of at least one function of a terminal of a communication system, comprising the steps of:

detecting a contact between a surface of the terminal and the skin of the user of the terminal; generating an output signal indicating a contact between the surface of the terminal and the skin of the user; and controlling said at least one function of the terminal based on the output signal.” Mantyjärvi at 4:4-5:10.

“Two strip electrodes 7 and 8 are attached on one side of the station 1. The electrodes 7 and 8 are employed for detecting a contact between the skin of the user and the mobile station.

According to a possibility the electrodes 7 and 8 are attached on the outer surface of the housing 11 of the mobile station 1.

The electrodes may also be embedded in the cover material such that the surface of the electrodes will remain visible and may thus be touched by the skin of the user.

More particularly, the electrodes 7 and 8 may be arranged to measure so called galvanic skin response (GSR). Figure 2 discloses a block diagram for circuitry that may be used when implementing a galvanic skin response touch sensing arrangement 20. The first electrode 7 is coupled to a voltage source V_{cc} via a line 27. The voltage V_{cc} may equal the operational voltage of the mobile station, but V_{cc} may also be different from that.

Voltage V_{cc} is preferably provided by the battery 10 of the mobile station 1. A buffer 21 and an appropriate impedance 24 8 may be provided for scaling the current and voltage on the line 27 between the electrode 7 and the voltage source V_{cc} . The second electrode 8 is coupled to an output 26 of the circuitry 20. The signal from the electrode 8 may be amplified by an amplifier 23 before the signal is output from the circuitry 20.

The amplifier circuit may comprise a resistor/ impedance 25. The galvanic skin response (GRS) detection method is based on provision of a conductive path between two or more electrodes.

When the user grips the mobile station 1 by his hand (not shown), the skin of the hand will provide the conductive path between the electrodes 7 and 8 of Figures 1 and 2. Now, when a conductive path is provided between the electrodes 7 and 8, the voltage and current at the output line 26 will change in accordance with known principles. The GSR sensing arrangement 20 gives typically so-called TTL level (transistor to transistor logic level) output signal when the conductive material is in touch with at least two of the electrodes. A component 22 may be used for setting an appropriate threshold level for the conductivity, i.e. the component 22 may trigger the circuitry 20 to output a signal that indicates a contact between the hand of the user and the mobile station 1.

As illustrated by the flow chart of figure 6, the output signal on line 26 may be used in the control of a function of the mobile station. For example, activation of a mobile station that is in a standby mode may be based on the output signal from the sensing arrangement. The activation of the mobile station may be triggered by the control unit 12 of the mobile station based on a received TTL level signal output 26 from the GSR arrangement 20. The station may be correspondingly deactivated i.e. returned 9 to the

standby mode after the control unit no longer receives the TTL level signal. An automated keyboard lock may function in a corresponding manner, i.e. the keyboard may be unlocked only when the GSR detecting arrangement outputs a TTL level signal. The station may also be switched between different modes of operation or even on and off based on the output signal received from the detecting means.” Mantyjärvi at 7:14-9:8.

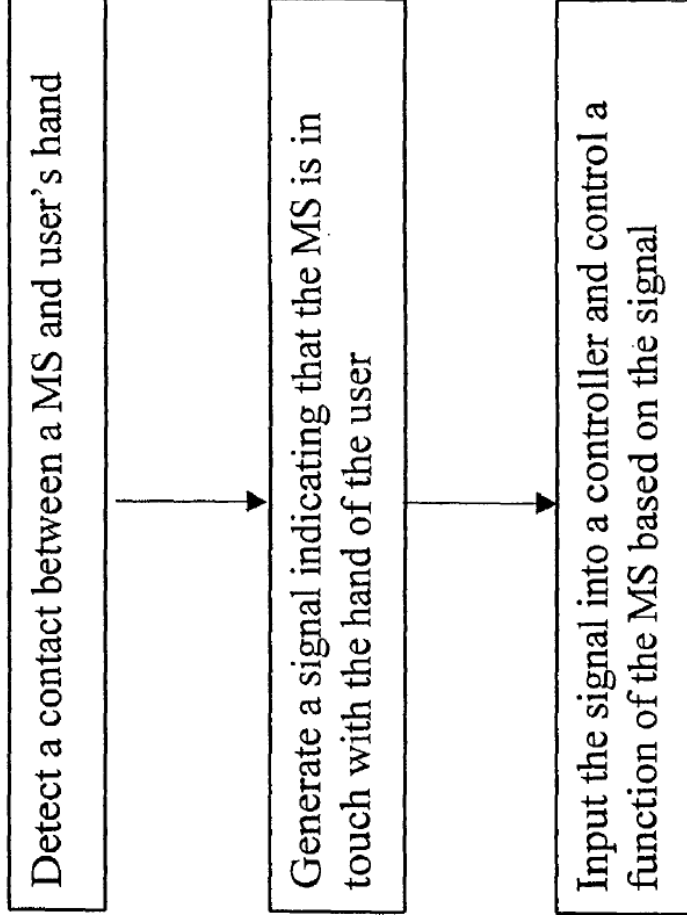

FIG. 6

Mantyjärvi at Fig. 6.

“It is also noted that the output signal from the detector arrangement may indicate a "positive" or "negative" contact. In other words, a signal may be outputted only when the terminal is in contact with the skin of the user or alternatively only when there is no contact between the user and the terminal.” Mantjarvi at 9:18-23.

“When the capacitive proximity sensor senses a living tissue, it may output an appropriate signal, such as a TTL level signal.” Mantjarvi at 10:30-11:1.

“Figure 4 shows a schematic block diagram for a detection circuitry 31 based on the capacitive proximity sensor detection.

In general, the circuitry 31 can be defined as oscillating circuitry that is implemented by means of a flip-flop switch 32.

The circuitry 31 is provided with suitable triggering means 33, such as a Schmitt trigger. An inverting amplifier 34 may also be provided on the output line 35. The circuitry operates such that when the capacitive sensor 30 is touched by a living tissue, the output on line 35 will rise in the Vcc level, thus providing a signal indicating that the terminal is in touch with living tissue.

The capacitive proximity sensor may also detect a living tissue, such as the skin of the user, that is not in an direct contact with the sensors. The skin may be, for example, within a distance that is up to 5 mm from the sensing electrode.

Therefore the capacitive proximity electrode 30 may be placed on the internal surface of the cover material of the terminal 1 or may be embedded within the cover material of the terminal 1. For example, it could be placed inside the cover of the battery 10 of the mobile terminal 1.” Mantjarvi at 11:5-25.

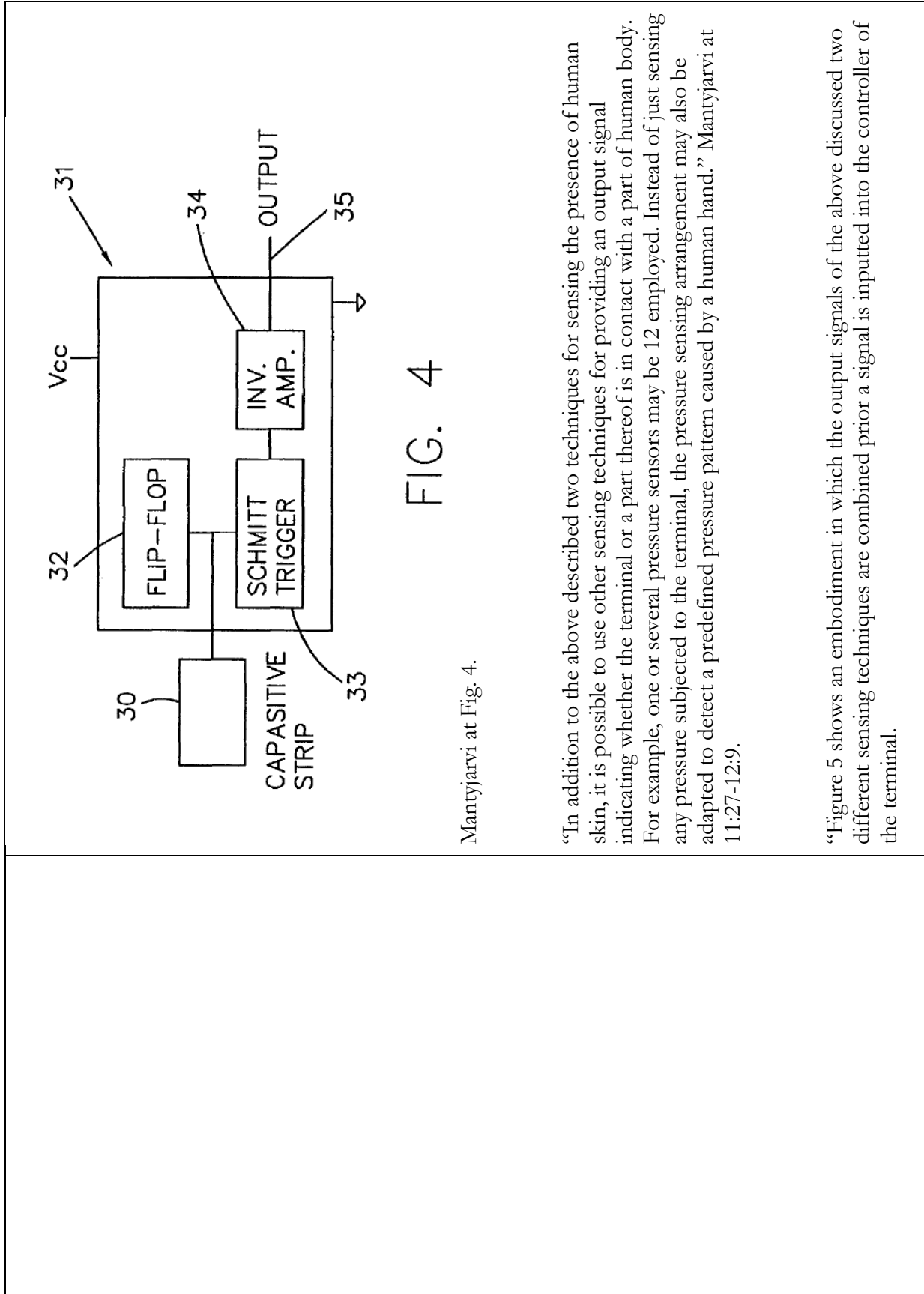

FIG. 4

Mantyarvi at Fig. 4.

“In addition to the above described two techniques for sensing the presence of human skin, it is possible to use other sensing techniques for providing an output signal indicating whether the terminal or a part thereof is in contact with a part of human body. For example, one or several pressure sensors may be 12 employed. Instead of just sensing any pressure subjected to the terminal, the pressure sensing arrangement may also be adapted to detect a predefined pressure pattern caused by a human hand.” Mantyarvi at 11:27-12:9.

“Figure 5 shows an embodiment in which the output signals of the above discussed two different sensing techniques are combined prior a signal is inputted into the controller of the terminal.

In brief, the arrangement of Figure 5 is such that an output signal 41 is provided by a combiner 40 only when both the galvanic skin response circuitry 20 and the capacitive proximity circuitry 31 provide a positive TTL level output signal to the combiner 40. By employing both the galvanic skin response and the capacitive proximity method in the same terminal it is possible to decrease the risk for incorrect signals and thus improve the reliability of the detection arrangement.” Mantyjärvi at 13:8-18.

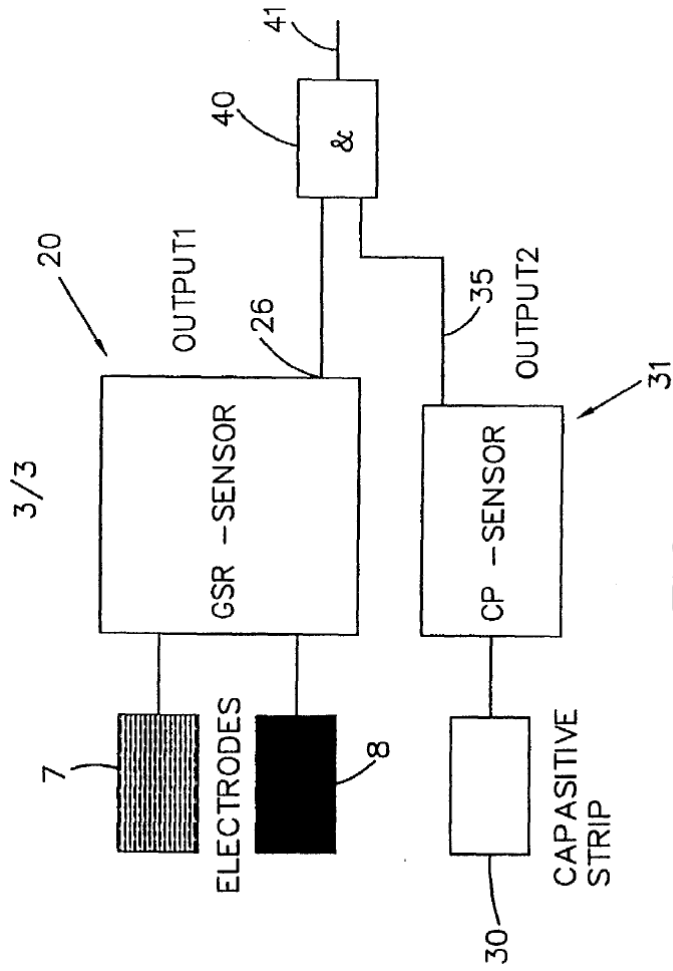

Mantyjärvi at Fig. 5.

“ 3. A terminal according to claim 2, wherein the control based on the signal from the detector means is provided only if said first and second detector arrangements both

	<p>output a signal that indicates a contact between the terminal and the skin of the user.” Mantyjarvi at Claim 3.</p> <p>“30. A method for providing control of at least one function of a terminal of a communication system, comprising the steps of:</p> <p>detecting a contact between a surface of the terminal and the skin of the user of the terminal; generating an output signal indicating a contact between the surface of the terminal and the skin of the user; and controlling said at least one function of the terminal based on the output signal.</p> <p>31. A method according to claim 30, wherein the generation of the output signal comprises further steps of:</p> <p>receiving a first signal from a first detector arrangement; 21 receiving a second signal from a second detector arrangement that is different from the operation principles thereof from the first detector arrangement; verifying the first and second signals; and generating the output signal if said first and second signals indicate similar results of detection.” Mantyjarvi at Claims 30-31.</p>
<p>[1f] (c) reduce power to the display if (i) the microprocessor determines that a telephone call is active and (ii) the signal indicates the proximity of the external object; wherein:</p>	<p>Mantyjarvi discloses the microprocessor adapted to reduce power to the display if (i) the microprocessor determines that a telephone call is active and (ii) the signal indicates the proximity of the external object.</p> <p>For example:</p> <p>“The present invention relates to a terminal for a communication system. The terminal includes detector means 7, 8 that are arranged to detect a contact between at least one surface of the terminal and the skin of the user. At least one function of the terminal is arranged to be controlled based on a signal generated by the detecting means in response to the detection. The sensor may be resistive, sensing galvanic skin resistance across</p>

linear contacts 7, 8 or could be a capacitive proximity sensor, or may be pressure sensitive.” Mantyjärvi at Abstract.

“The user typically controls the operation and/or functions of the terminal by pressing appropriate buttons on a keyboard of the terminal or by lifting the handset off-hook/placing the handset on-hook or opening/closing a specific cover connected to a switch and so on. Voice activated control systems are also known. For example, when the user wishes to establish a call, he usually selects or fetches the desired destination number by pressing appropriate keys on the keyboard or he may use possible voice activation functions of the terminal. When the user receives a call, the call is typically answered by lifting the handset off-hook, or by pressing at least one key of the key board or by opening the special cover of the keyboard.

Similarly, any other functions of the terminal may be controlled by pressing appropriate keys or moving one or several components of the terminal to operate an associated switch. The functions and/or operations that need to be controlled may be functions such as switching the terminal between different modes of operation, controlling a keyboard lock or display of the terminal, switching on/off the lightning of the keyboard or the display, or controlling any other special features of the terminal or services provided for the user of the terminal (such as voice mail, short text messages, calendar or alarm functions and so on).

For example, a mobile station may be provided with a keyboard lock referred to above. The basic idea of the keypad or keyboard lock is to prevent the user to mistakenly press any of the keys when this is not desired (e.g. when the mobile station is in the pocket of the user). For example, by means of the lock it is possible to prevent an accidental call establishment to a telephone number that is not actually selected. The keyboard lock may be controlled in alternative ways. According to one possibility predefined keys of the keypad can be used for locking and unlocking the keypad of the mobile station.” Mantyjärvi at 2:11-3:15.

“According to one aspect of the present invention, there is provided a terminal for a communication system, the terminal comprising detector means that are arranged to detect a contact between at least one surface of the terminal and the skin of the user of the terminal, wherein at least one function of the terminal is controlled based on a signal from the detecting means.

The detector means may comprise a first detector arrangement and a second detector arrangement, wherein said first and second detector arrangements are based on different principles of detecting a contact between the terminal and the skin of the user. The control of the terminal that is based on the signal from the detector means is preferably provided only if said first and second detector arrangements both output a signal that indicates a contact between the terminal and the skin of the user.

According to one aspect of the present invention, there is provided a detector arrangement for a terminal of a communication system, the terminal comprising at least one element that is to be held against the skin of the user of the terminal, the detector arrangement comprising circuitry for generating an output signal whenever a surface of the terminal touches in a predefined manner the skin of the user, wherein the output signal is arranged to be employed in the control of at least one function of the terminal.

According to another aspect of the present invention, there is provided a method for providing control of at least one function of a terminal of a communication system, comprising the steps of:

detecting a contact between a surface of the terminal and the skin of the user of the terminal; generating an output signal indicating a contact between the surface of the terminal and the skin of the user; and controlling said at least one function of the terminal based on the output signal.” Mantjarvi at 4:4-5:10.

“Two strip electrodes 7 and 8 are attached on one side of the station 1. The electrodes 7 and 8 are employed for detecting a contact between the skin of the user and the mobile station. According to a possibility the electrodes 7 and 8 are attached on the outer surface of the housing 11 of the mobile station 1. The electrodes may also be embedded in the

cover material such that the surface of the electrodes will remain visible and may thus be touched by the skin of the user.

More particularly, the electrodes 7 and 8 may be arranged to measure so called galvanic skin response (GSR). Figure 2 discloses a block diagram for circuitry that may be used when implementing a galvanic skin response touch sensing arrangement 20. The first electrode 7 is coupled to a voltage source V_{cc} via a line 27. The voltage V_{cc} may equal the operational voltage of the mobile station, but V_{cc} may also be different from that. Voltage V_{cc} is preferably provided by the battery 10 of the mobile station 1. A buffer 21 and an appropriate impedance 24 8 may be provided for scaling the current and voltage on the line 27 between the electrode 7 and the voltage source V_{cc} . The second electrode 8 is coupled to an output 26 of the circuitry 20. The signal from the electrode 8 may be amplified by an amplifier 23 before the signal is output from the circuitry 20. The amplifier circuit may comprise a resistor/ impedance 25.

The galvanic skin response (GSR) detection method is based on provision of a conductive path between two or more electrodes. When the user grips the mobile station 1 by his hand (not shown), the skin of the hand will provide the conductive path between the electrodes 7 and 8 of Figures 1 and 2. Now, when a conductive path is provided between the electrodes 7 and 8, the voltage and current at the output line 26 will change in accordance with known principles. The GSR sensing arrangement 20 gives typically so-called TTL level (transistor to transistor logic level) output signal when the conductive material is in touch with at last two of the electrodes. A component 22 may be used for setting an appropriate threshold level for the conductivity, i.e. the component 22 may trigger the circuitry 20 to output a signal that indicates a contact between the hand of the user and the mobile station 1.” Mantjarvi at 7:14-8:22.

“As illustrated by the flow chart of figure 6, the output signal on line 26 may be used in the control of a function of the mobile station. As illustrated by the flow chart of figure 6, the output signal on line 26 may be used in the control of a function of the mobile station. For example, activation of a mobile station that is in a standby mode may be based on the output signal from the sensing arrangement. The activation of the mobile station may be triggered by the control unit 12 of the mobile station based on a received

TTL level signal output 26 from the GSR arrangement 20. The station may be correspondingly deactivated i.e. returned 9 to the standby mode after the control unit no longer receives the TTL level signal. An automated keyboard lock may function in a corresponding manner, i.e. the keyboard may be unlocked only when the GSR detecting arrangement outputs a TTL level signal. The station may also be switched between different modes of operation or even on and off based on the output signal received from the detecting means. The lighting of the keypad and/or the display may be controlled based on this information.” Mäntyjärvi at 8:24-9:8.

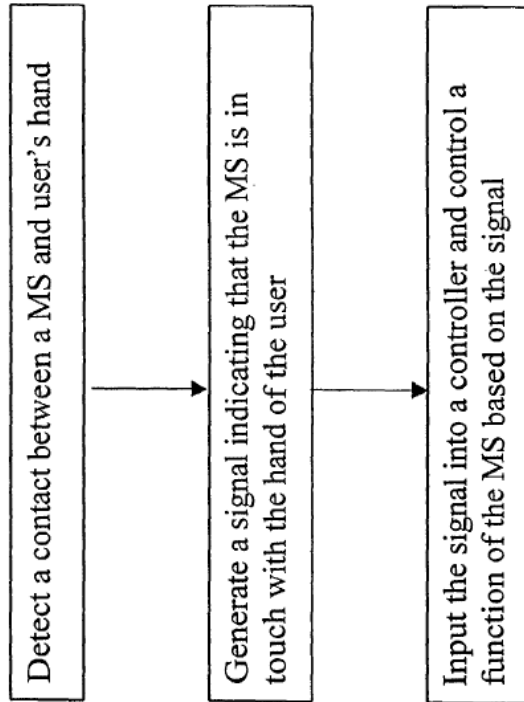

FIG. 6

Mäntyjärvi at Fig. 6.

“The controller may provide different instructions for the controlled functions depending the location or the context where the control is provided. For example, during

a normal speech call the lighting of the display and/or keyboard may be switched off after a predefined time has lapsed from the activation thereof. However, the lightning will stay on if the connection was established for data communication, such as for a wireless application protocol (WAP) connection or for an Internet connection.”
Mantyjärvi at 14:21-30.

“Another possibility for measuring the presence of the living tissue in touch or in close proximity with the terminal is so called capacitive proximity (CP) sensor. The capacitive proximity sensor requires only one electrode, even though it is possible to use several CP sensors. The CP based system can be adjusted to sense the proximity of the living tissue, for example such that a CP sensing arrangement will react when the distance between the skin of the user and the mobile station is within a range of 0 to 5 mm. The capacitive proximity sensors may be arranged to be sensitive only for living tissue, and will thus not react to other materials. When the capacitive proximity sensor senses a living tissue, it may output an appropriate signal, such as a TTL level signal. The use of the TTL level output signal in accordance with the invention was already discussed above.

Figure 4 shows a schematic block diagram for a detection circuitry 31 based on the capacitive proximity sensor detection. In general, the circuitry 31 can be defined as oscillating circuitry that is implemented by means of a flip-flop switch 32. The circuitry 31 is provided with suitable triggering means 33, such as a Schmitt trigger. An inverting amplifier 34 may also be provided on the output line 35. The circuitry operates such that when the capacitive sensor 30 is touched by a living tissue, the output on line 35 will rise in the Vcc level, thus providing a signal indicating that the terminal is in touch with living tissue.

The capacitive proximity sensor may also detect a living tissue, such as the skin of the user, that is not in an direct contact with the sensors. The skin may be, for example, within a distance that is up to 5 mm from the sensing electrode. Therefore the capacitive proximity electrode 30 may be placed on the internal surface of the cover material of the terminal 1 or may be embedded within the cover material of the terminal 1. For example,

it could be placed inside the cover of the battery 10 of the mobile terminal 1.” Mantyjärvi at 10:20-11:25.

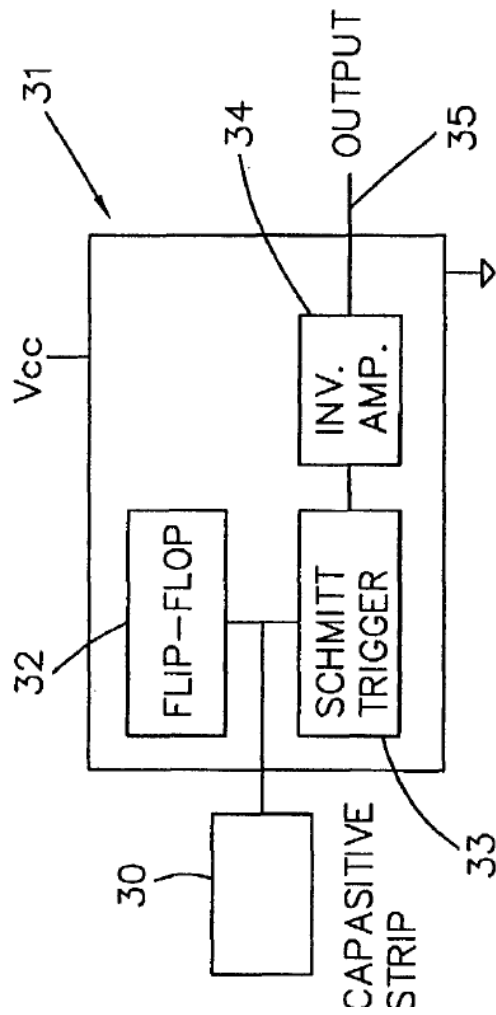

FIG. 4

Mantyjärvi at Fig. 4.

“Figure 5 shows an embodiment in which the output signals of the above discussed two different sensing techniques are combined prior a signal is inputted into the controller of the terminal.

In brief, the arrangement of Figure 5 is such that an output signal 41 is provided by a combiner 40 only when both the galvanic skin response circuitry 20 and the capacitive proximity circuitry 31 provide a positive TTL level output signal to the combiner 40. By

employing both the galvanic skin response and the capacitive proximity method in the same terminal it is possible to decrease the risk for incorrect signals and thus improve the reliability of the detection arrangement.” Mäntyjärvi at 13:8-18.

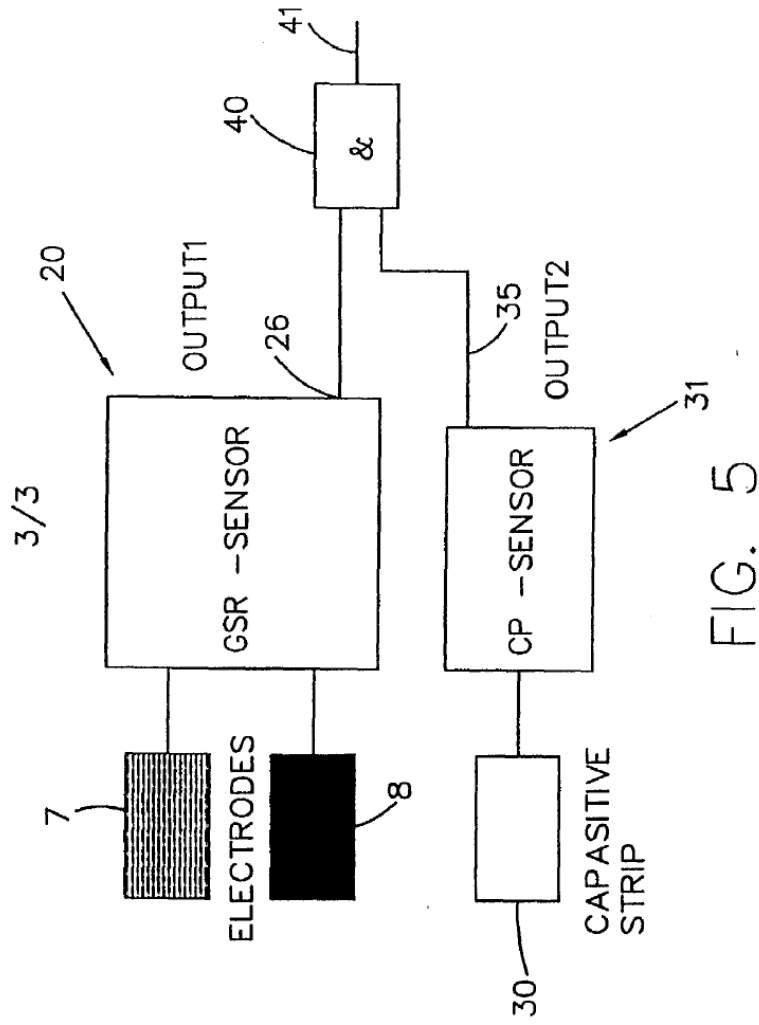

Mäntyjärvi at Fig. 5.

“The controller may provide different instructions for the controlled functions depending the location or the context where the control is provided. For example, during a normal speech call the lighting of the display and/or keyboard may be switched off

after a predefined time has lapsed from the activation thereof. However, the lightning will stay on if the connection was established for data communication, such as for a wireless application protocol (WAP) connection or for an Internet connection.”
Mantyjärvi at 14:21-30.

“Therefore a verification of the detection result of a detection arrangement may be desirable in some applications. The verification can be provided by employing more than one sensing technique in the generation of the output signal to make sure that the terminal is indeed in the hand of the user or against the cheek or ear of the user.”
Mantyjärvi at 13:2-6.

“1. A terminal for a communication system, the terminal comprising detector means that are arranged to detect a contact between at least one surface of the terminal and the skin of the user of the terminal, wherein at least one function of the terminal is controlled based on a signal from the detecting means.” Mantyjärvi at Claim 1.

“2. A terminal according to claim 1, wherein the detector means comprise a first detector arrangement and a second detector arrangement, wherein said first and second detector arrangements are based on different principles of detecting a contact between the terminal and the skin of the user.” Mantyjärvi at Claim 2

“3. A terminal according to claim 2, wherein the control based on the signal from the detector means is provided only if said first and second detector arrangements both output a signal that indicates a contact between the terminal and the skin of the user.”
Mantyjärvi at Claim 3.

“ 24. A terminal according to any of the preceding claims, wherein the control of the function is based, in addition to the signal from the detector means, on at least one of the following: the operational status of the terminal; the location of the terminal; the time of the day; the time of the year; temperature; the type of the communication.” Mantyjärvi at Claim 24.

“27. A detector arrangement for a terminal of a communication system, the terminal comprising at least one element that is to be held against the skin of the user of the terminal, the detector arrangement comprising circuitry for generating an output signal whenever a surface of the terminal touches in a predefined manner the skin of the user, wherein the output signal is arranged to be employed in the control of at least one function of the terminal.” Mantyjärvi at Claim 27.

“31. A method according to claim 30, wherein the generation of the output signal comprises further steps of:

receiving a first signal from a first detector arrangement; 21 receiving a second signal from a second detector arrangement that is different from the operation principles thereof from the first detector arrangement; verifying the first and second signals; and generating the output signal if said first and second signals indicate similar results of detection.” Mantyjärvi at Claim 33

To the extent Mantyjärvi is deemed to not expressly disclose the microprocessor adapted to “(c) reduce power to the display if (i) the microprocessor determines that a telephone call is active and (ii) the signal indicates the proximity of the external object,” Mantyjärvi inherently discloses this limitation or renders it obvious to a person of ordinary skill in

<p>[1g] the telephone call is a wireless telephone call;</p>	<p>the art at the time of the alleged invention for the reasons described in claim element [1h], <i>in/ra</i>, incorporate herein by reference.</p>
<p>[1g] the telephone call is a wireless telephone call;</p>	<p>Mantylarvi discloses the telephone call as a wireless telephone call.</p> <p>For example:</p> <p>“In a communication system a terminal is used for providing a user interface for the user of the communication system. In other words, by means of the terminal the user may access and communicate over the communication system.</p> <p>An example of the terminal is a mobile station that may be used in a radio communication system. The mobile station is typically a portable hand-held device that provides, in cooperation with the radio communication system, mobility for the user. When the mobile station is not in use, it is usually positioned in the user's pocket or in a special case or similar. The mobile station typically comprises a keypad for controlling the operation thereof, such as for dialing in a desired telephone number and for controlling various functions of the mobile station. A mobile station is also typically provided with a display. The display may be used for showing various information to the user of the mobile station. Instead of being an entirely hand-held unit, a mobile station may also comprise separate units, such as a base transceiver unit and a separate handset portion and/or a separate headset portion.” Mantylarvi at 1:10-29.</p> <p>“Figure 1 shows a mobile station in accordance with an embodiment of the present invention. The mobile station 1 comprises a housing or cover portion 11 which protects and encapsulates the various internal components of the mobile station. The internal components are not shown in greater detail, but may typically comprise components such as a processor 12 that is for controlling one or several functions of the mobile station.” Mantylarvi at 6:10-16.</p>

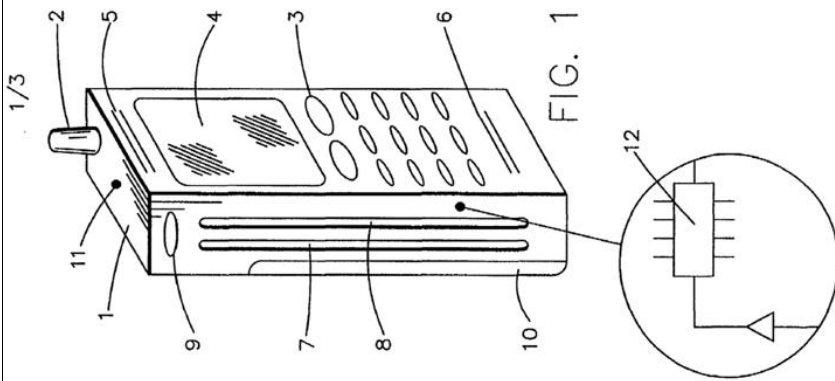

Mantjarvi at Fig. 1.

26. A terminal according to any of the preceding claims, wherein the terminal comprises a mobile station of a radio communication system.” Mantjarvi at Claim 26.

	<p>For example: <i>see</i> discussion of claim element 1[d], <i>supra</i>, which is incorporated herein by reference.</p>
<p>[1h] the microprocessor reduces power to the display while the signal indicates the proximity of the external object only if the microprocessor determines that the wireless telephone call is active; and</p>	<p>Mantjarvi discloses that the microprocessor reduces power to the display while the signal indicates the proximity of the external object only if the microprocessor determines that the wireless telephone call is active:</p> <p>For example:</p> <p><i>See</i> discussion of claim element [1f], <i>supra</i>, which is incorporated herein by reference.</p> <p>To the extent Mantjarvi is deemed to not disclose “the microprocessor reduces power to the display while the signal indicates the proximity of the external object only if the microprocessor determines that the wireless telephone call is active,” Mantjarvi renders this limitation obvious to one of ordinary skill in the art at the time of the alleged invention. For example, Mantjarvi discloses that “[i]n addition, the sensitivity of the control unit of the mobile station can be adjusted in accordance with specific requirements and/or conditions and may vary if the requirements and/or conditions change. According to an embodiment other information may also be employed when providing the control of a function of the terminal. For example, it may be desired to be able to adjust the sensitivity in accordance with the changed temperature conditions, as a cold hand is less conductive than a warm (and thus sweaty) hand. The controller may provide different instructions for the controlled functions depending the location or the context where the control is provided.” Mantjarvi at 14-15. A person of ordinary skill in the art at the time of the alleged invention would understand Mantjarvi’s disclosure of modifying the “sensitivity of the control unit” based on “specific requirements and/or conditions,” including that “[t]he controller may provide different instructions for the controlled functions depending the location or the context where the control is provided “as rendering obvious microprocessor reduces power to the display while the signal indicates the proximity of the external object only if the microprocessor determines that the wireless telephone call is active.” For example, one of ordinary skill in the art at the time of the alleged invention would understand that they could “modify the sensitivity” of the microprocessor for controlling functions such as turning off the display of the</p>

mobile station, by requiring the microprocessor to determine “that the wireless telephone call is active” in addition to receiving a “signal indicat[ing] the proximity of the external object” before it performs the function of shutting off the display. Such a modification would be obvious to one of ordinary skill in the art at the time of the alleged invention when “conditions” warrant that the microprocessor detect both the wireless telephone call and the signal from the proximity sensor, such as, for example, when there is reason to doubt the accuracy of the signal of the proximity sensor in insolation. In fact Mantiyarvi discloses the possibility of such circumstances. *See* Mantiyarvi at 12:27-13:2 (“Therefore there may be, in some circumstances, a possibility to get an incorrect output signal from the detector means 20 of Figure 2. The close proximity (CP) 30 method may also give false signals, for example when there is a very thin textile between the electrode and the human skin. Therefore a verification of the detection result of a detection arrangement may be desirable in some applications.”). It would therefore be obvious to one of ordinary skill in the art to modify Mantiyarvi such that “the microprocessor reduces power to the display while the signal indicates the proximity of the external object only if the microprocessor determines that the wireless telephone call is active,” or to combine Mantiyarvi with other art that discloses this limitation (see discussion of combination with Fukiharu 598, below). Doing so would be within the knowledge and ability of a person of ordinary skill in the art at the time of the alleged invention. Doing so would also constitute, at least, combining prior art elements according to known methods to yield predictable results, a simple substitution of one known element for another to obtain predictable results, the use of a known technique to improve similar devices in the same way, the application of a known technique to a known device ready for improvement to yield a predictable result, and obvious to try.

To the extent Mantiyarvi is deemed to not expressly or inherently disclose the microprocessor adapted to the microprocessor reduces power to the display while the signal indicates the proximity of the external object only if the microprocessor determines that the wireless telephone call is active,” it would be obvious to combine the disclosure of Mantiyarvi with those of Fukiharu 598 as described in the Fukiharu 598 claim chart, which is incorporated herein in its entirety by reference. Mantiyarvi and Fukiharu 598 are both directed to controlling the functionality of mobile stations based

in part on signals from a proximity sensor. *See, e.g.,* Mantyjärvi at 3:30-4:2 (“It is an aim of the embodiments of the present invention to address one or several of the disadvantages of the prior art terminals and to provide a new type of solution for controlling one or several functions of a terminal.”); Fukiharu 598 at Abstract (“The object of the present invention is to provide a mobile telephone with a lighting device, and a method for controlling said lighting device, with improved portability through reducing the weight and volume of the battery, and to enable a thorough increase in talk time and standby time, through controlling, through a touch sensor that is provided on a receiver portion surface of the mobile telephone, operation of a lighting device (backlight) of a liquid crystal display device and/or a key pad portion.”). More particularly both Mantyjärvi and Fukiharu 598 disclose turning off the display of a mobile station based on signals from a proximity sensor indicating that a user’s face or ear is in close proximity to the mobile station. *See, e.g.,* Mantyjärvi at Claim 1 (“A terminal for a communication system, the terminal comprising detector means that are arranged to detect a contact between at least one surface of the terminal and the skin of the user of the terminal, wherein at least one function of the terminal is controlled based on a signal from the detecting means.”), Mantyjärvi at Claim 8 (“A terminal according to any of the preceding claims, wherein the operation of a display of the terminal is controlled based on the signal from the detector means.”), Mantyjärvi at Claim 11 (“A terminal according to any of the preceding claims, wherein the detector means are arranged to sense a contact between the terminal and the cheek and/or ear of the user.”); Fukiharu 598 at ¶0015 (“At this time, the lighting-ON state is maintained if not in the voice communication mode. If in the voice communication mode, a touch sensor 2c is placed into an operating state by a signal from the controlling portion 2a, and constantly outputs a detection output to the controlling portion 2a. If the touch sensor 2c contacts a portion of the human body, such as an ear, a lighting-OFF signal is outputted to the lighting device ON/OFF circuit portion 2b from the controlling portion 2a through the ON output of the touch sensor 2c, and the power supplies to both the lighting device (backlight) 3a and the lighting device (backlight) 4a go to the OFF state, and this lighting-OFF state is maintained until the touch sensor 2c goes into a non-contact state.”). A person of ordinary skill in the art at the time of the alleged invention would therefore understand that both Mantyjärvi and Fukiharu 598 disclose ways of conserving battery power by shutting of the display of a mobile station at such times that the user of the mobile station is unlikely to be looking at the display (as indicated by at least a proximity

	<p>sensor). A person of ordinary skill in the art at the time of the alleged invention would be therefore be motivated to modify Mantiyarvi such that “the microprocessor reduces power to the display while the signal indicates the proximity of the external object only if the microprocessor determines that the wireless telephone call is active,” as disclosed in Fukiharu 598 for a number of different reasons, including that it would support Mantiyarvi’s ability to conserve battery power in mobile stations. Doing so would further support Mantiyarvi’s ability to provide means for “controlling of at least one function of a terminal of a communication system” (Mantiyarvi at 1:5-6) where the “sensitivity of the control unit of the mobile station can be adjusted in accordance with specific requirements and/or conditions and may vary if the requirements and/or conditions change.” Mantiyarvi at 14:13-16. Doing so would be within the knowledge and ability of a person of ordinary skill in the art at the time of the alleged invention. The combination would constitute, at least, combining prior art elements according to known methods to yield predictable results, a simple substitution of one known element for another to obtain predictable results, the use of a known technique to improve similar devices in the same way, the application of a known technique to a known device ready for improvement to yield a predictable result, and obvious to try.</p>
<p>[11] the proximity sensor begins detecting whether an external object is proximate substantially concurrently with the mobile station initiating an outgoing wireless telephone call or receiving an incoming wireless telephone call.</p>	<p>Mantiyarvi discloses the proximity sensor beginning to detect whether an external object is proximate substantially concurrently with the mobile station initiating an outgoing wireless telephone call or receiving an incoming wireless telephone call:</p> <p>For example:</p> <p><i>See</i> discussion of claim element [1f], <i>supra</i>, which is incorporated herein by reference.</p> <p>“According to one aspect of the present invention, there is provided a terminal for a communication system, the terminal comprising detector means that are arranged to detect a contact between at least one surface of the terminal and the skin of the user of</p>

the terminal, wherein at least one function of the terminal is controlled based on a signal from the detecting means.

The detector means may comprise a first detector arrangement and a second detector arrangement, wherein said first and second detector arrangements are based on different principles of detecting a contact between the terminal and the skin of the user. The control of the terminal that is based on the signal from the detector means is preferably provided only if said first and second detector arrangements both output a signal that indicates a contact between the terminal and the skin of the user.

According to one aspect of the present invention, there is provided a detector arrangement for a terminal of a communication system, the terminal comprising at least one element that is to be held against the skin of the user of the terminal, the detector arrangement comprising circuitry for generating an output signal whenever a surface of the terminal touches in a predefined manner the skin of the user, wherein the output signal is arranged to be employed in the control of at least one function of the terminal.

According to another aspect of the present invention, there is provided a method for providing control of at least one function of a terminal of a communication system, comprising the steps of:

detecting a contact between a surface of the terminal and the skin of the user of the terminal; generating an output signal indicating a contact between the surface of the terminal and the skin of the user; and controlling said at least one function of the terminal based on the output signal.” Mantjarvi at 4:4-5:10.

“As illustrated by the flow chart of figure 6, the output signal on line 26 may be used in the control of a function of the mobile station. As illustrated by the flow chart of figure 6, the output signal on line 26 may be used in the control of a function of the mobile station. For example, activation of a mobile station that is in a standby mode may be based on the output signal from the sensing arrangement. The activation of the mobile station may be triggered by the control unit 12 of the mobile station based on a received TTL level signal output 26 from the GSR arrangement 20. The station may be

correspondingly deactivated i.e. returned 9 to the standby mode after the control unit no longer receives the TTL level signal. An automated keyboard lock may function in a corresponding manner, i.e. the keyboard may be unlocked only when the GSR detecting arrangement outputs a TTL level signal. The station may also be switched between different modes of operation or even on and off based on the output signal received from the detecting means. The lighting of the keypad and/or the display may be controlled based on this information.’ Mantyjärvi at 8:24-9:8.

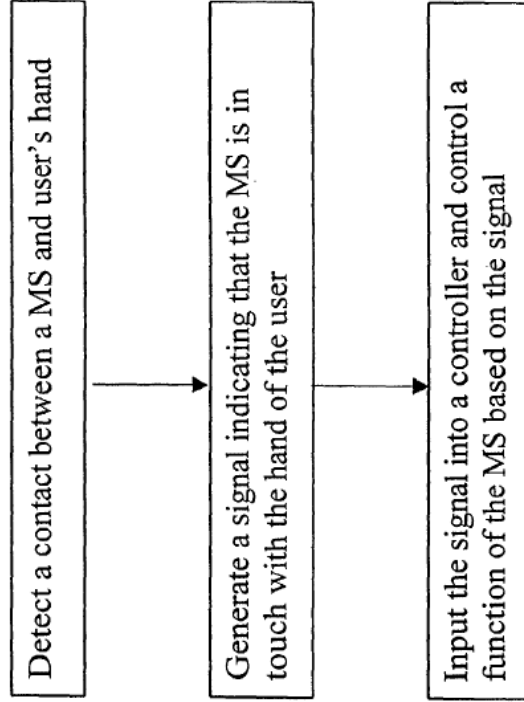
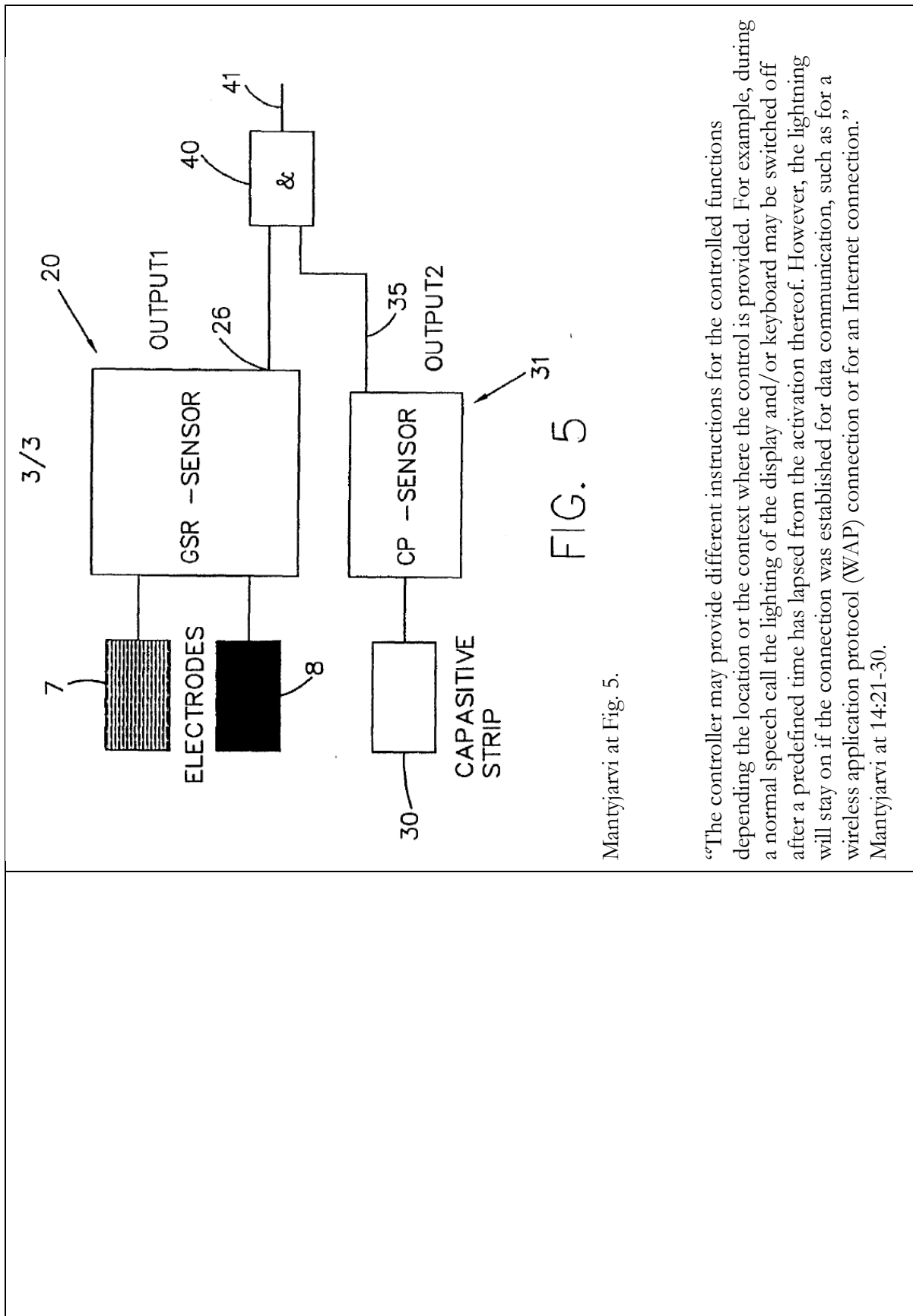

FIG. 6

Mantyjärvi at Fig. 6.

“Figure 5 shows an embodiment in which the output signals of the above discussed two different sensing techniques are combined prior a signal is inputted into the controller of the terminal.

In brief, the arrangement of Figure 5 is such that an output signal 41 is provided by a combiner 40 only when both the galvanic skin response circuitry 20 and the capacitive proximity circuitry 31 provide a positive TTL level output signal to the combiner 40. By employing both the galvanic skin response and the capacitive proximity method in the same terminal it is possible to decrease the risk for incorrect signals and thus improve the reliability of the detection arrangement.” Mäntyjärvi at 13:8-18.



Mantjarvi at Fig. 5.

FIG. 5

“The controller may provide different instructions for the controlled functions depending the location or the context where the control is provided. For example, during a normal speech call the lighting of the display and/or keyboard may be switched off after a predefined time has lapsed from the activation thereof. However, the lightning will stay on if the connection was established for data communication, such as for a wireless application protocol (WAP) connection or for an Internet connection.”
 Mantjarvi at 14:21-30.

“The sensing arrangement may also be adapted such that it will take changes in the time of the day and/or seasons of the year or changes in the conductivity of the components used for the sensors into account. The adjustment may also be adaptive so that the controller may itself adjust the operation thereof to be within certain predefined parameters.” Mantiyarvi at 14:30-15:4.

“Therefore a verification of the detection result of a detection arrangement may be desirable in some applications. The verification can be provided by employing more than one sensing technique in the generation of the output signal to make sure that the terminal is indeed in the hand of the user or against the cheek or ear of the user.” Mantiyarvi at 13:2-6.

“1. A terminal for a communication system, the terminal comprising detector means that are arranged to detect a contact between at least one surface of the terminal and the skin of the user of the terminal, wherein at least one function of the terminal is controlled based on a signal from the detecting means.” Mantiyarvi at Claim 1.

“2. A terminal according to claim 1, wherein the detector means comprise a first detector arrangement and a second detector arrangement, wherein said first and second detector arrangements are based on different principles of detecting a contact between the terminal and the skin of the user.” Mantiyarvi at Claim 2.

“3. A terminal according to claim 2, wherein the control based on the signal from the detector means is provided only if said first and second detector arrangements both

output a signal that indicates a contact between the terminal and the skin of the user.”
Mantjarvi at Claim 3.

“24. A terminal according to any of the preceding claims, wherein the control of the function is based, in addition to the signal from the detector means, on at least one of the following: the operational status of the terminal; the location of the terminal; the time of the day; the time of the year; temperature; the type of the communication.” Mantjarvi at Claim 24.

“27. A detector arrangement for a terminal of a communication system, the terminal comprising at least one element that is to be held against the skin of the user of the terminal, the detector arrangement comprising circuitry for generating an output signal whenever a surface of the terminal touches in a predefined manner the skin of the user, wherein the output signal is arranged to be employed in the control of at least one function of the terminal.” Mantjarvi at Claim 27.

“31. A method according to claim 30, wherein the generation of the output signal comprises further steps of:

receiving a first signal from a first detector arrangement; 21 receiving a second signal from a second detector arrangement that is different from the operation principles thereof from the first detector arrangement; verifying the first and second signals; and generating the output signal if said first and second signals indicate similar results of detection.” Mantjarvi at Claim 33.

To the extent Mantjarvi is deemed to not disclose that “the proximity sensor begins detecting whether an external object is proximate substantially concurrently with the

mobile station initiating an outgoing wireless telephone call or receiving an incoming wireless telephone call.” Mantiyarvi renders this limitation obvious to one of skill in the art. Mantiyarvi discloses that a mobile station “may also be switched between different modes of operation or even on and off based on the output signal received from the detecting means. The lighting of the keypad and/or the display may be controlled based on this information.” Mantiyarvi at 9:5-8. Mantiyarvi also discloses “receiving a first signal from a first detector arrangement; 21 receiving a second signal from a second detector arrangement that is different from the operation principles thereof from the first detector arrangement; verifying the first and second signals; and generating the output signal if said first and second signals indicate similar results of detection.” Mantiyarvi at Claim 33. A person of ordinary skill in the art at the time of the alleged invention would be motivated to modify Mantiyarvi to disclose this claim element because in order to determine whether “the first and second signals indicate similar results of detection,” the two signals should be temporally similar. Further, a person of ordinary skill in the art at the time of the alleged invention would be motivated to modify Mantiyarvi in this way because doing so would improve Mantiyarvi’s desired function of enabling a mobile station “to be controlled based on a signal generated by the detecting means in response to the detection.” Mantiyarvi at Abstract. It would not be difficult for a skilled artisan to modify Mantiyarvi’s mobile station such that its “proximity sensor begins detecting whether an external object is proximate substantially concurrently with the mobile station initiating an outgoing wireless telephone call or receiving an incoming wireless telephone call.” because the mobile station in Mantiyarvi is already configured to determine that a telephone call is active, and to reduce power to the display if the signal indicates the proximity of the external object. *See* discussion of claim elements 1[b], 1[d], 1[f], *supra*. This modification would thereby produce predictable results. Doing so would be within the knowledge and ability of a person of ordinary skill in the art at the time of the alleged invention. Doing so would also constitute, at least, combining prior art elements according to known methods to yield predictable results, a simple substitution of one known element for another to obtain predictable results, the use of a known technique to improve similar devices in the same way, the application of a known technique to a known device ready for improvement to yield a predictable result, and obvious to try.

To the extent Mانتىجارى is deemed to not expressly or inherently disclose that “the proximity sensor begins detecting whether an external object is proximate substantially concurrently with the mobile station initiating an outgoing wireless telephone call or receiving an incoming wireless telephone call,” it would be obvious to combine the disclosure of Mانتىجارى with those of Fukiharu 598 as described in the Fukiharu 598 claim chart, which is incorporated herein in its entirety by reference. Mانتىجارى and Fukiharu 598 are both directed to controlling the functionality of mobile stations based in part on signals from a proximity sensor. *See, e.g.*, Mانتىجارى at 3:30-4:2 (“It is an aim of the embodiments of the present invention to address one or several of the disadvantages of the prior art terminals and to provide a new type of solution for controlling one or several functions of a terminal.”); Fukiharu 598 at Abstract (“The object of the present invention is to provide a mobile telephone with a lighting device, and a method for controlling said lighting device, with improved portability through reducing the weight and volume of the battery, and to enable a thorough increase in talk time and standby time, through controlling, through a touch sensor that is provided on a receiver portion surface of the mobile telephone, operation of a lighting device (backlight) of a liquid crystal display device and/or a key pad portion.”). More particularly both Mانتىجارى and Fukiharu 598 disclose turning off the display of a mobile station based on signals from a proximity sensor indicating that a user’s face or ear is in close proximity to the mobile station. *See, e.g.*, Mانتىجارى at Claim 1 (“A terminal for a communication system, the terminal comprising detector means that are arranged to detect a contact between at least one surface of the terminal and the skin of the user of the terminal, wherein at least one function of the terminal is controlled based on a signal from the detecting means.”), Mانتىجارى at Claim at 8 (“A terminal according to any of the preceding claims, wherein the operation of a display of the terminal is controlled based on the signal from the detector means.”), Mانتىجارى at Claim 11 (“A terminal according to any of the preceding claims, wherein the detector means are arranged to sense a contact between the terminal and the cheek and/or ear of the user.”); Fukiharu 598 at ¶0015 (“At this time, the lighting-ON state is maintained if not in the voice communication mode. If in the voice communication mode, a touch sensor 2c is placed into an operating state by a signal from the controlling portion 2a, and constantly outputs a detection output to the controlling portion 2a. If the touch sensor 2c contacts a portion of the human body, such as an ear, a lighting-OFF signal is outputted to the lighting device ON/OFF circuit portion 2b from the controlling portion 2a through the ON

	<p>output of the touch sensor 2c, and the power supplies to both the lighting device (backlight) 3a and the lighting device (backlight) 4a go to the OFF state, and this lighting-OFF state is maintained until the touch sensor 2c goes into a non-contact state.”). A person of ordinary skill in the art at the time of the alleged invention would therefore understand that both Mantlyjarvi and Fukiharu 598 disclose ways of conserving battery power by shutting of the display of a mobile station at such times that the user of the mobile station is unlikely to be looking at the display (as indicted by at least a proximity sensor). A person of ordinary skill in the art at the time of the alleged invention would be therefore be motivated to modify Mantlyjarvi such that “the proximity sensor begins detecting whether an external object is proximate substantially concurrently with the mobile station initiating an outgoing wireless telephone call or receiving an incoming wireless telephone call,” as disclosed in Fukiharu 598 for a number of different reasons, including that it would support Mantlyjarvi’s ability to conserve battery power in mobile stations. Doing so would further support Mantlyjarvi’s ability to provide means for “controlling of at least one function of a terminal of a communication system” (Mantlyjarvi at 1:5-6) where the “sensitivity of the control unit of the mobile station can be adjusted in accordance with specific requirements and/or conditions and may vary if the requirements and/or conditions change.” Mantlyjarvi at 14:13-16. Doing so would be within the knowledge and ability of a person of ordinary skill in the art at the time of the alleged invention. The combination would constitute, at least, combining prior art elements according to known methods to yield predictable results, a simple substitution of one known element for another to obtain predictable results, the use of a known technique to improve similar devices in the same way, the application of a known technique to a known device ready for improvement to yield a predictable result, and obvious to try.</p>
<p>[Claim 2] The mobile station of claim 1, wherein the microprocessor reduces power to the display only if (i) the microprocessor determines that a telephone call is active and</p>	<p>Mantlyjarvi discloses the microprocessor reducing power to the display only if (i) the microprocessor determines that a telephone call is active and (ii) the signal indicates the proximity of the external object.</p>

<p>(ii) the signal indicates the proximity of the external object.</p>	<p>For example: <i>See</i> discussion of claim element [1f], <i>supra</i>, which is incorporated herein by reference.</p>
<p>[Claim 4] The mobile station as recited in claim 1, wherein the microprocessor reduces power to the display by turning off the display.</p>	<p>Mantjarvi discloses the microprocessor reducing power to the display by turning off the display.</p> <p>For example:</p> <p>“The controller may provide different instructions for the controlled functions depending the location or the context where the control is provided. For example, during a normal speech call the lighting of the display and/or keyboard may be switched off after a predefined time has lapsed from the activation thereof. However, the lightning will stay on if the connection was established for data communication, such as for a wireless application protocol (WAP) connection or for an Internet connection.” Mantjarvi at 14:21-30.</p> <p>“The station may also be switched between different modes of operation or even on and off based on the output signal received from the detecting means. The lighting of the keypad and/or the display may be controlled based on this information.” Mantjarvi at 9:5-8.</p> <p>“Similarly, any other functions of the terminal may be controlled by pressing appropriate keys or moving one or several components of the terminal to operate an associated switch. The functions and/or operations that need to be controlled may be functions such as switching the terminal between different modes of operation, controlling a keyboard lock or display of the terminal, switching on/off the lightning of the keyboard or the display, or controlling any other special features of the terminal or services provided for the user of the terminal (such as voice mail, short text messages, calendar or alarm functions and so on).” Mantjarvi at 2:23-3:2.</p>

	<p>“The embodiments of the invention may provide an automated and reliable control of at least one function, such as the keyboard lock and/or switching between different modes of operation of the terminal (e.g. standby and activated) and/or special service or feature. The embodiments may make the use of the terminal more convenient. The embodiments may prevent any unwanted activation of one or several of the functions of the terminal while the terminal is not in use.” Mantyjärvi at 5:12-19.</p> <p>See discussion of claim element [1f], <i>supra</i>, which is incorporated herein by reference.</p> <p>To the extent Mantyjärvi is deemed to not expressly disclose that “the microprocessor reduces power to the display by turning off the display,” Mantyjärvi inherently discloses this limitation. Specifically, Mantyjärvi states that “[t]he station may also be switched between different modes of operation or even on and off based on the output signal received from the detecting means. The lighting of the keypad and/or the display may be controlled based on this information.” Mantyjärvi at 9:5-8. A person of skilled in the art would understand that if the mobile station in Mantyjärvi may be “switched...on and off based on the output signal received from the detecting means,” the mobile station necessarily reduces power to the display by turning off the display.</p> <p>To the extent Mantyjärvi is deemed to not expressly or inherently disclose “the microprocessor reduces power to the display by turning off the display,” Mantyjärvi renders it obvious to one of skill in the art. A person of ordinary skill in the art at the time of the alleged invention would be motivated to modify Mantyjärvi’s mobile station to reduce power to the display by turning off the display because doing so would improve Mantyjärvi’s desired function of enabling a mobile station “to be controlled based on a signal generated by the detecting means in response to the detection.” Mantyjärvi at Abstract.</p>
<p>[Claim 5] The mobile station as recited in claim 1, wherein the proximity sensor is a</p>	<p>Mantyjärvi discloses that the proximity sensor is a mechanical proximity sensor, an optical sensor, or a range-detecting sensor.</p>

mechanical proximity sensor, an optical sensor, or a range-detecting sensor.

For example:

See discussion of claim element [1b], *supra*, which is incorporated herein by reference.

To the extent Mantjarvi is deemed to not expressly disclose “the proximity sensor is a mechanical proximity sensor, an optical sensor, or a range-detecting sensor,” Mantjarvi inherently discloses this limitation. In Mantjarvi, detector means 7, 8, can detect the “contact” from them human body. *See* Mantjarvi at Abstract (“The terminal includes detector means 7, 8 that are arranged to detect a contact between at least one surface of the terminal and the skin of the user. At least one function of the terminal is arranged to be controlled based on a signal generated by the detecting means in response to the detection. The sensor may be resistive, sensing galvanic skin resistance across linear contacts 7, 8 or could be a capacitive proximity sensor, or may be pressure sensitive.”) A person of ordinary skill in the art at the time of the alleged invention would understand that detecting this contact is accomplished by mechanical proximity sensor. Thus, a person of ordinary skill in the art at the time of the alleged invention would understand Mantjarvi to inherently disclose “the proximity sensor is a mechanical proximity sensor, an optical sensor, or a range-detecting sensor.”

To the extent Mantjarvi is deemed to not expressly or inherently disclose “the proximity sensor is a mechanical proximity sensor, an optical sensor, or a range-detecting sensor,” Mantjarvi renders it obvious to one of ordinary skill in the art at the time of the alleged invention to use a mechanical proximity sensor. A person of ordinary skill in the art at the time of the alleged invention would be aware of “conventional mechanical proximity (load) sensors,” which the ’889 Patent identifies as known prior art. *See* ’889 Patent at 3:15-20. A person of ordinary skill in the art at the time of the alleged invention would understand that a mechanical proximity sensor could be used to detect contact with a portion of the human body, such as an ear. Using a mechanical proximity sensor would constitute, at least, combining prior art elements according to known methods to yield predictable results, a simple substitution of one known element for another to obtain predictable results, the use of a known technique to improve similar devices in the same

way, the application of a known technique to a known device ready for improvement to yield a predictable result, and obvious to try.

To the extent Mantyjärvi is deemed to not expressly or inherently disclose that “the proximity sensor is a mechanical proximity sensor, an optical sensor, or a range-detecting sensor,” it would be obvious to combine the disclosure of Mantyjärvi with those of Fukiharu 598 as described in the Fukiharu 598 claim chart, which is incorporated herein in its entirety by reference. Mantyjärvi and Fukiharu 598 are both directed to controlling the functionality of mobile stations based in part on signals from a proximity sensor. See, e.g., Mantyjärvi at 3:30-4:2 (“It is an aim of the embodiments of the present invention to address one or several of the disadvantages of the prior art terminals and to provide a new type of solution for controlling one or several functions of a terminal.”); Fukiharu 598 at Abstract (“The object of the present invention is to provide a mobile telephone with a lighting device, and a method for controlling said lighting device, with improved portability through reducing the weight and volume of the battery, and to enable a thorough increase in talk time and standby time, through controlling, through a touch sensor that is provided on a receiver portion surface of the mobile telephone, operation of a lighting device (backlight) of a liquid crystal display device and/or a key pad portion.”). More particularly both Mantyjärvi and Fukiharu 598 disclose turning off the display of a mobile station based on signals from a proximity sensor indicating that a user’s face or ear is in close proximity to the mobile station. See, e.g., Mantyjärvi at Claim 1 (“A terminal for a communication system, the terminal comprising detector means that are arranged to detect a contact between at least one surface of the terminal and the skin of the user of the terminal, wherein at least one function of the terminal is controlled based on a signal from the detecting means.”), Mantyjärvi at Claim 8 (“A terminal according to any of the preceding claims, wherein the operation of a display of the terminal is controlled based on the signal from the detector means.”), Mantyjärvi at Claim 11 (“A terminal according to any of the preceding claims, wherein the detector means are arranged to sense a contact between the terminal and the cheek and/or ear of the user.”); Fukiharu 598 at ¶0015 (“At this time, the lighting-ON state is maintained if not in the voice communication mode. If in the voice communication mode, a touch sensor 2c is placed into an operating state by a signal from the controlling portion 2a, and

	<p>constantly outputs a detection output to the controlling portion 2a. If the touch sensor 2c contacts a portion of the human body, such as an ear, a lighting-OFF signal is outputted to the lighting device ON/OFF circuit portion 2b from the controlling portion 2a through the ON output of the touch sensor 2c, and the power supplies to both the lighting device (backlight) 3a and the lighting device (backlight) 4a go to the OFF state, and this lighting-OFF state is maintained until the touch sensor 2c goes into a non-contact state.”). A person of ordinary skill in the art at the time of the alleged invention would therefore understand that both Mantyjärvi and Fukiharu 598 disclose ways of conserving battery power by shutting of the display of a mobile station at such times that the user of the mobile station is unlikely to be looking at the display (as indicted by at least a proximity sensor). A person of ordinary skill in the art at the time of the alleged invention would be therefore be motivated to modify Mantyjärvi such that “the proximity sensor is a mechanical proximity sensor, an optical sensor, or a range-detecting sensor,” as disclosed in Fukiharu 598 for a number of different reasons, including that it would support Mantyjärvi’s ability to conserve battery power in mobile stations. Doing so would further support Mantyjärvi’s ability to provide means for “controlling of at least one function of a terminal of a communication system” (Mantyjärvi at 1:5-6) where the “sensitivity of the control unit of the mobile station can be adjusted in accordance with specific requirements and/or conditions and may vary if the requirements and/or conditions change.” Mantyjärvi at 14:13-16. Doing so would be within the knowledge and ability of a person of ordinary skill in the art at the time of the alleged invention. The combination would constitute, at least, combining prior art elements according to known methods to yield predictable results, a simple substitution of one known element for another to obtain predictable results, the use of a known technique to improve similar devices in the same way, the application of a known technique to a known device ready for improvement to yield a predictable result, and obvious to try.</p>
<p>[Claim 6] The mobile station as recited in claim 1, wherein the proximity sensor is located proximate to the display.</p>	<p>Mantyjärvi discloses that the proximity sensor is located proximate to the display.</p> <p>For example:</p>

“The electrodes or sensors can be arranged in many alternative ways on the surface of the mobile station 1. For example, one of the electrodes could be positioned on one side surface of the station like the electrode 7 (or 8) of Figure 1 while another electrode could be placed on the opposite side surface of the mobile station or on the back or front surface of the mobile station. It may be difficult in some instances to measure the GSR response by only two electrodes, for example because different users tend to hold the mobile station in different ways.

Therefore it may be advantageous to provide the terminal with more than two electrodes. The electrodes may also be positioned in an appropriate array. Figure 3 shows one possibility for such an array, even though there are various different alternatives for this. The array of the electrodes could be placed, for example, on the back surface of the mobile station.

According to an alternative the mobile station or some parts thereof is covered with an electrically conductive material, such as a metallic coating, and an appropriate isolation is provided between the various parts of the cover. The material of the housing 11 itself may be made from a conductive material. Thus the housing 11 of the mobile station 1 may also be used as a sensing electrode.” Mäntylä at 8:25-9:18.

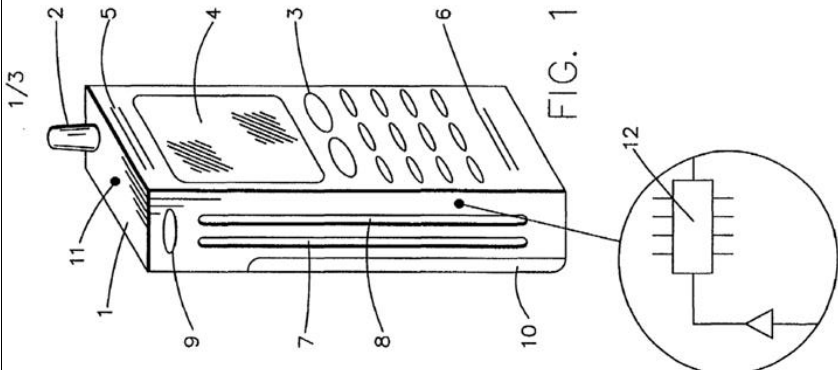

Mantjarvi at Fig. 1.

To the extent Mantjarvi is deemed to not expressly disclose that the proximity sensor is located proximate to the display, Mantjarvi inherently discloses this limitation.

Specifically, a person of ordinary skill in the art at the time of the alleged invention would understand that one or more of the sensors identified in Figs. 4 and 5, as illustrated by Fig. 1 of Mantjarvi necessarily is located proximate to the display. Moreover, it would have been obvious to one of ordinary skill in the art to modify this reference so as to include this claim limitation in light of the knowledge possessed by one of ordinary skill in the art. Further, this claim limitation would have been obvious in light of the other U.S. patents, U.S. patent publications, articles, and products identified in Huawei's

contentions with respect to this limitation, and it would have been obvious to combine these references to a person of ordinary skill in the art, as discussed further in Huawei's invalidity contention cover pleading.

To the extent Mantiyarvi is deemed to not expressly disclose “the proximity sensor is located proximate to the display,” Mantiyarvi inherently discloses this limitation. Mantiyarvi discloses that its invention cuts power to the display during a call when the user has the receiver against his or her ear. A person of ordinary skill in the art at the time of the alleged invention would understand that when a user is holding a mobile station up against their head during a call, the user's ear will make contact with the display and if the proximity sensor is to detect this contact, it necessarily would be “located proximate to the display.” Thus, a person of ordinary skill in the art at the time of the alleged invention would understand Mantiyarvi to inherently disclose that “the proximity sensor is located proximate to the display.”

To the extent Mantiyarvi is deemed to not expressly or inherently disclose “the proximity sensor is located proximate to the display,” Mantiyarvi renders it obvious to one of skill in the art to have “the proximity sensor . . . located proximate to the display.” It would be obvious to a person of ordinary skill in the art at the time of the alleged invention that “the proximity sensor is located proximate to the display” because, in this location, it can detect that the user's head is against the mobile station (and the display). This would constitute, at least, combining prior art elements according to known methods to yield predictable results, a simple substitution of one known element for another to obtain predictable results, the use of a known technique to improve similar devices in the same way, the application of a known technique to a known device ready for improvement to yield a predictable result, and obvious to try.

To the extent Mantiyarvi is deemed to not expressly or inherently disclose that “the proximity sensor is located proximate to the display,” it would be obvious to combine the

disclosure of Mantiyarvi with those of Fukiharu 598 as described in the Fukiharu 598 claim chart, which is incorporated herein in its entirety by reference. Mantiyarvi and Fukiharu 598 are both directed to controlling the functionality of mobile stations based in part on signals from a proximity sensor. See, e.g., Mantiyarvi at 3:30-4:2 (“It is an aim of the embodiments of the present invention to address one or several of the disadvantages of the prior art terminals and to provide a new type of solution for controlling one or several functions of a terminal.”); Fukiharu 598 at Abstract (“The object of the present invention is to provide a mobile telephone with a lighting device, and a method for controlling said lighting device, with improved portability through reducing the weight and volume of the battery, and to enable a thorough increase in talk time and standby time, through controlling, through a touch sensor that is provided on a receiver portion surface of the mobile telephone, operation of a lighting device (backlight) of a liquid crystal display device and/or a key pad portion.”). More particularly both Mantiyarvi and Fukiharu 598 disclose turning off the display of a mobile station based on signals from a proximity sensor indicating that a user’s face or ear is in close proximity to the mobile station. See, e.g., Mantiyarvi at Claim 1 (“A terminal for a communication system, the terminal comprising detector means that are arranged to detect a contact between at least one surface of the terminal and the skin of the user of the terminal, wherein at least one function of the terminal is controlled based on a signal from the detecting means.”), Mantiyarvi at Claim at 8 (“A terminal according to any of the preceding claims, wherein the operation of a display of the terminal is controlled based on the signal from the detector means.”), Mantiyarvi at Claim 11 (“A terminal according to any of the preceding claims, wherein the detector means are arranged to sense a contact between the terminal and the cheek and/or ear of the user.”); Fukiharu 598 at ¶0015 (“At this time, the lighting-ON state is maintained if not in the voice communication mode. If in the voice communication mode, a touch sensor 2c is placed into an operating state by a signal from the controlling portion 2a, and constantly outputs a detection output to the controlling portion 2a. If the touch sensor 2c contacts a portion of the human body, such as an ear, a lighting-OFF signal is outputted to the lighting device ON/OFF circuit portion 2b from the controlling portion 2a through the ON output of the touch sensor 2c, and the power supplies to both the lighting device (backlight) 3a and the lighting device (backlight) 4a go to the OFF state, and this lighting-OFF state is maintained until the touch sensor 2c goes into a non-contact state.”). A person of ordinary skill in the art at the time of the alleged invention would therefore

	<p>understand that both Mantyjärvi and Fukiharu 598 disclose ways of conserving battery power by shutting of the display of a mobile station at such times that the user of the mobile station is unlikely to be looking at the display (as indicted by at least a proximity sensor). A person of ordinary skill in the art at the time of the alleged invention would be therefore be motivated to modify Mantyjärvi such that “the proximity sensor is located proximate to the display,” as disclosed in Fukiharu 598 for a number of different reasons, including that it would support Mantyjärvi’s ability to conserve battery power in mobile stations. Doing so would further support Mantyjärvi’s ability to provide means for “controlling of at least one function of a terminal of a communication system” (Mantyjärvi at 1:5-6) where the “sensitivity of the control unit of the mobile station can be adjusted in accordance with specific requirements and/or conditions and may vary if the requirements and/or conditions change.” Mantyjärvi at 14:13-16. Doing so would be within the knowledge and ability of a person of ordinary skill in the art at the time of the alleged invention. The combination would constitute, at least, combining prior art elements according to known methods to yield predictable results, a simple substitution of one known element for another to obtain predictable results, the use of a known technique to improve similar devices in the same way, the application of a known technique to a known device ready for improvement to yield a predictable result, and obvious to try.</p>
<p>[Claim 8 – Preamble] 8. A method of conserving battery power in a mobile station, comprising:</p>	<p>To the extent the preamble is construed as limiting, Mantyjärvi discloses a method of conserving battery power in a mobile station.</p> <p>For example: <i>see</i> discussion of claim 1, <i>supra</i>, which is incorporated herein by reference.</p>
<p>[8a] detecting whether an external object is proximate;</p>	<p>Mantyjärvi discloses detecting whether an external object is proximate:</p> <p>For example: <i>see</i> discussion of claim element [1b], <i>supra</i>, which is incorporated herein by reference.</p>

<p>[8b] determining whether a telephone call is active; and</p>	<p>Mantjarvi discloses determining whether a telephone call is active.</p> <p>For example: <i>see</i> discussion of claim element [1d], <i>supra</i>, which is incorporated herein by reference.</p> <p>To the extent Mantjarvi is deemed to not expressly disclose this claim limitation, Mantjarvi inherently discloses this limitation. <i>See</i> discussion of claim element [1d], <i>supra</i>, which is incorporated herein by reference.</p> <p>To the extent Mantjarvi is deemed to not expressly or inherently disclose this claim limitation, Mantjarvi renders it obvious to one of skill in the art at the time of the alleged invention. <i>See</i> discussion of claim element [1d], <i>supra</i>, which is incorporated herein by reference.</p> <p>To the extent Mantjarvi is deemed to not expressly or inherently disclose this claim element, it would be obvious to combine the disclosure of Mantjarvi with those of Fukiharu 598 as described in the Fukiharu 598 claim chart, which is incorporated herein in its entirety by reference. <i>See</i> discussion of claim element [1d], <i>supra</i>, which is incorporated herein by reference.</p>
<p>[8c] reducing power consumption of a display of the mobile station if (i) a telephone call is determined to be active and (ii) the proximity of the external object is detected; wherein:</p>	<p>Mantjarvi discloses reducing power consumption of a display of the mobile station if (i) a telephone call is determined to be active and (ii) the proximity of the external object is detected.</p> <p>For example: <i>see</i> discussion of claim element [1f], <i>supra</i>, which is incorporated herein by reference.</p>

	<p>To the extent Mantyjärvi is deemed to not expressly disclose this claim limitation, Mantyjärvi inherently discloses this limitation. <i>See</i> discussion of claim element [1h], <i>supra</i>, which is incorporated herein by reference.</p> <p>To the extent Mantyjärvi is deemed to not expressly or inherently disclose this claim limitation, Mantyjärvi renders it obvious to one of skill in the art at the time of the alleged invention. <i>See</i> discussion of claim element [1h], <i>supra</i>, which is incorporated herein by reference.</p> <p>To the extent Mantyjärvi is deemed to not expressly or inherently disclose this claim element, it would be obvious to combine the disclosure of Mantyjärvi with those of Fukiharu 598 as described in the Fukiharu 598 claim chart, which is incorporated herein in its entirety by reference. <i>See</i> discussion of claim element [1h], <i>supra</i>, which is incorporated herein by reference.</p>
<p>[8d] the telephone call is a wireless telephone call;</p>	<p>Mantyjärvi discloses that the telephone call is a wireless telephone call:</p> <p><i>See</i> discussion of claim element [1g], <i>supra</i>, which is incorporated herein by reference.</p>
<p>[8e] the power consumption of the display is reduced while the proximity of the external object is detected only if the wireless telephone call is determined to be active; and</p>	<p>Mantyjärvi discloses that the power consumption of the display is reduced while the proximity of the external object is detected only if the wireless telephone call is determined to be active.</p> <p>For example: <i>see</i> discussion of claim element [1h], <i>supra</i>, which is incorporated herein by reference.</p> <p>To the extent Mantyjärvi is deemed to not expressly disclose this claim limitation, Mantyjärvi inherently discloses this limitation. <i>See</i> discussion of claim element [1h], <i>supra</i>, which is incorporated herein by reference.</p> <p>To the extent Mantyjärvi is deemed to not expressly or inherently disclose this claim limitation, Mantyjärvi renders it obvious to one of skill in the art at the time of the alleged</p>

	<p>invention. <i>See</i> discussion of claim element [1h], <i>supra</i>, which is incorporated herein by reference.</p> <p>To the extent Mantyjärvi is deemed to not expressly or inherently disclose this claim element, it would be obvious to combine the disclosure of Mantyjärvi with those of Fukiharu 598 as described in the Fukiharu 598 claim chart, which is incorporated herein in its entirety by reference. <i>See</i> discussion of claim element [1h], <i>supra</i>, which is incorporated herein by reference.</p>
<p>[8f] detecting whether an external object is proximate begins substantially concurrently with the mobile station initiating an outgoing wireless telephone call or receiving an incoming wireless telephone call.</p>	<p>Mantyjärvi discloses that detecting whether an external object is proximate begins substantially concurrently with the mobile station initiating an outgoing wireless telephone call or receiving an incoming wireless telephone call.</p> <p>For example: <i>see</i> discussion of claim element [1i], <i>supra</i>, which is incorporated herein by reference.</p> <p>To the extent Mantyjärvi is deemed to not expressly disclose this claim limitation, Mantyjärvi inherently discloses this limitation. <i>See</i> discussion of claim element [1i], <i>supra</i>, which is incorporated herein by reference.</p> <p>To the extent Mantyjärvi is deemed to not expressly or inherently disclose this claim limitation, Mantyjärvi renders it obvious to one of skill in the art at the time of the alleged invention. <i>See</i> discussion of claim element [1i], <i>supra</i>, which is incorporated herein by reference.</p> <p>To the extent Mantyjärvi is deemed to not expressly or inherently disclose this claim element, it would be obvious to combine the disclosure of Mantyjärvi with those of Fukiharu 598 as described in the Fukiharu 598 claim chart, which is incorporated herein in its entirety by reference. <i>See</i> discussion of claim element [1i], <i>supra</i>, which is incorporated herein by reference.</p>

<p>[Claim 12] The method as recited in claim 8, wherein the detecting of the proximity of the external object is performed by a mechanical proximity sensor, an optical sensor, or a range-detecting sensor.</p>	<p>Mantyjärvi discloses that the detecting of the proximity of the external object is performed by a mechanical proximity sensor, an optical sensor, or a range-detecting sensor:</p> <p><i>See</i> discussion of claim 5, <i>supra</i>, which is incorporated herein by reference.</p> <p>To the extent Mantyjärvi is deemed to not expressly disclose this claim limitation, Mantyjärvi inherently discloses this limitation. <i>See</i> discussion of claim 5, <i>supra</i>, which is incorporated herein by reference.</p> <p>To the extent Mantyjärvi is deemed to not expressly or inherently disclose this claim limitation, Mantyjärvi renders it obvious to one of skill in the art at the time of the alleged invention. <i>See</i> discussion of claim 5, <i>supra</i>, which is incorporated herein by reference.</p> <p>To the extent Mantyjärvi is deemed to not expressly or inherently disclose this claim element, it would be obvious to combine the disclosure of Mantyjärvi with those of Fukiharu 598 as described in the Fukiharu 598 claim chart, which is incorporated herein in its entirety by reference. <i>See</i> discussion of claim 5, <i>supra</i>, which is incorporated herein by reference.</p>
--	---

Exhibit A7

**Exhibit A7-Sparre
to Defendants' Preliminary Invalidity Contentions**

**Invalidity Chart for U.S. Patent No. 7,319,889
World Intellectual Property Organization Publication No. WO 00/78012 (“Sparre”)**

World Intellectual Property Organization Publication No. WO 00/78012 to Sparre (“Sparre”). Sparre was filed on June 8, 2000 and published on December 21, 2000. Sparre is prior art to the '889 Patent under at least pre-AIA §§ 102(b) and 102(e). Sparre anticipates or renders obvious, alone or in combination with other prior art references, each of the Asserted Claims of the '889 Patent as described in the chart below and in the main invalidity contentions document to which this chart is annexed.

It would have been obvious under 35 U.S.C. § 103 to a person having ordinary skill in the art at the time of the alleged invention to combine the teachings of Sparre with the following references:

1. Japanese Unexamined Patent Application Publication No. 2000-106598 to Fukiharu (“Fukiharu 598”). Fukiharu 598 qualifies as prior art under at least pre-AIA §§ 102(a), 102(b), and 102(e). Fukiharu 598 was published on April 11, 2000.

<u>Asserted Claims</u>	<u>Corresponding Disclosure in the Prior Art Reference(s)</u>
[Claim 1 – Preamble] 1. A mobile station, comprising:	<p>Sparre discloses a mobile station.</p> <p>For example:</p> <p>“Examples of portable electric apparatuses as set out above are for instance mobile or cellular telephones, wireless telephone handsets, personal communicators, portable digital assistants, palmtop computers, etc. The users thereof are dependent of a fully functional apparatus. More specifically, one of the most common problems in this respect is the limited operational duration between subsequent chargings of a battery used for supplying power to the apparatus. While it has been possible to reach reduced power consumption through the development of low-voltage, high-density integrated circuits, battery capacity is still a major obstacle against full user freedom in terms of virtually unlimited operational duration. Consequently, preservation of electric power is still a very important issue within the field of portable electric apparatuses. For the rest of this document, reference is made to a mobile telephone, which is chosen to</p>

represent a portable electric apparatus according to the invention. However, the invention shall in no way be limited to merely a mobile telephone. In a mobile telephone, the liquid crystal display (LCD) is responsible for a significant part of the total power consumption thereof.” Sparre at 1-2.

“An example of a portable electric apparatus is given in FIG 1 in the form of a mobile telephone 1 having a housing 10, an antenna 2 mounted on top of the housing, a status indicator LED 3, a speaker 4, volume adjustment controls 5, an LCD display 6 and a keypad 7. The keypad 7 has a plurality of individual keys, such as a YES button 12 and a NO button 13, arrow keys 14, 15, a clear key 16, numeric keys 17 (labeled 0 through 9), a star key 18 and a hash key 19.” Sparre at 8.

“FIG 1 is a schematic front view of a portable electric apparatus, exemplified as a mobile telephone, having a liquid crystal display and a proximity detector according to the invention.” Sparre at 7-8.

1/2

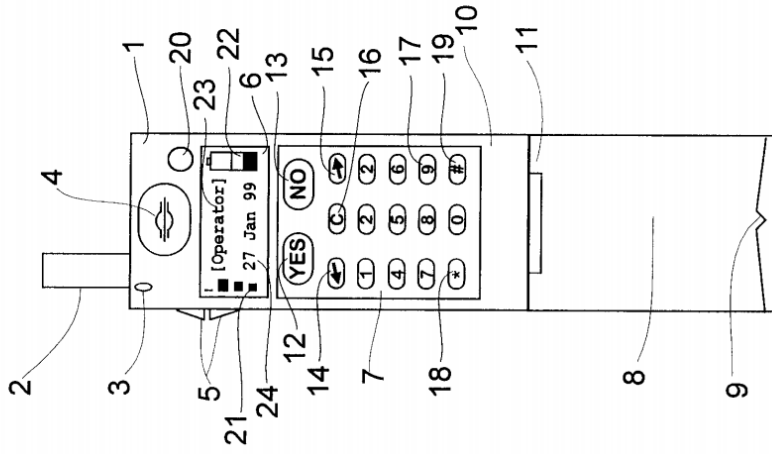
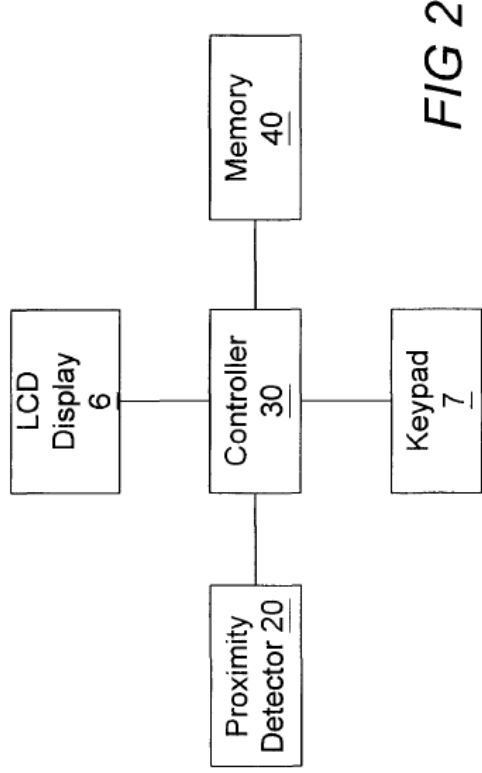

FIG 1

Sparre at Fig. 1.

“The main components of the mobile telephone 1 are shown in FIG 2. A controller 30 is operatively connected to the display 6, the keypad 7, the proximity detector 20 and a memory 40. The controller 30 may be any microprocessor, central processing unit (CPU) or other piece of electronic logic circuitry already used in the telephone 1 for performing the various functions thereof (such as telephone call control, keypad control, display control, or execution of utility programs such as a calculator program, electronic game programs, etc) . Alternatively, the controller 30 may be realized by

separate electronic logic circuitry, which in itself is generally known, such as a microprocessor, an integrated circuit network, etc. Correspondingly, the memory 40 may be of any type generally known within the field of portable electric apparatuses, such as an EEPROM memory, a RAM memory, a flash memory etc.” Sparre at 10-11.



Sparre at Fig. 2.

“10. A portable electric apparatus (1) according to any preceding claim, wherein the apparatus is a telecommunication device, preferably a mobile telephone (1).” Sparre at Claim 10.

[1a] a display;

Sparre discloses a display.

For example:

“FIG 1 is a schematic front view of a portable electric apparatus, exemplified as a mobile telephone, having a liquid crystal display and a proximity detector according to the invention.” Sparre at 7-8.

“An example of a portable electric apparatus is given in FIG 1 in the form of a mobile telephone 1 having a housing 10, an antenna 2 mounted on top of the housing, a status indicator LED 3, a speaker 4, volume adjustment controls 5, an LCD display 6 and a keypad . . . The liquid crystal display 6 is arranged according to the description in the Prior Art section of this document, i.e. comprises two glass plates with a layer of liquid crystals provided between them, together with a control line matrix placed on either sides of the two glass plates. As previously described, the graphical information presented on the display 6 is controlled by supplying electric energy from the display driver through the control line matrix to the liquid crystal layer. The display 6 is shown in an active state in FIG 1 and comprises graphical symbols or icons for presenting a received signal strength indicator 21, a remaining battery charge indicator 22, information about the active network operator 23 as well as the current date 24. Consequently, the liquid crystal display 6 consumes a certain amount of electric energy, depending on the supply of electric energy to the liquid crystal layer.” Sparre at 8-9.

“The liquid crystal display 6 also has an inactive state, where less or even no electric energy is supplied to the liquid crystal layer and, thus, less visual information is presented on the display. In contrast to the active state, during which all graphical information (e.g. the icons 21-24) is presented on the display, only parts of this graphical information is shown on the display during its inactive state. For instance, with reference to FIG 1, only the remaining battery charge indicator 22 (but not the icons 21, 22 or 24) is presented on the display 6 during its inactive state. Such an inactive state essentially corresponds to the "limited icon mode", which was described in the Prior Art section of this document. Alternatively, the liquid crystal display 6 may be completely turned off in its inactive state (i.e., no electric energy is supplied to the

liquid crystal layer, wherein the power consumption of the display is essentially zero).” Sparre at 9.

“A proximity detector is provided at the uppermost portion of the front surface of the telephone 1. In the embodiment shown in FIG 1, the proximity detector 20 is located immediately above the display 6 next to the speaker 4. However, the exact location of the proximity detector 20 is not critical but may be varied between many different positions, as long as the functional requirements specified below are satisfied.” Sparre at 9.

1/2

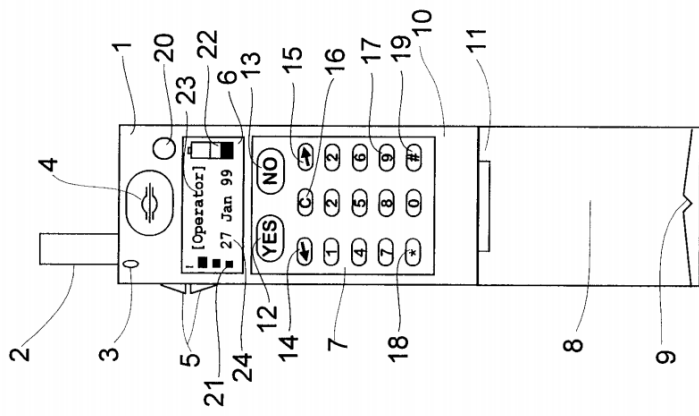

FIG 1

Sparre at Fig. 1.

“The main components of the mobile telephone 1 are shown in FIG 2. A controller 30 is operatively connected to the display 6, the keypad 7, the proximity detector 20 and a memory 40.” Sparre at 10.

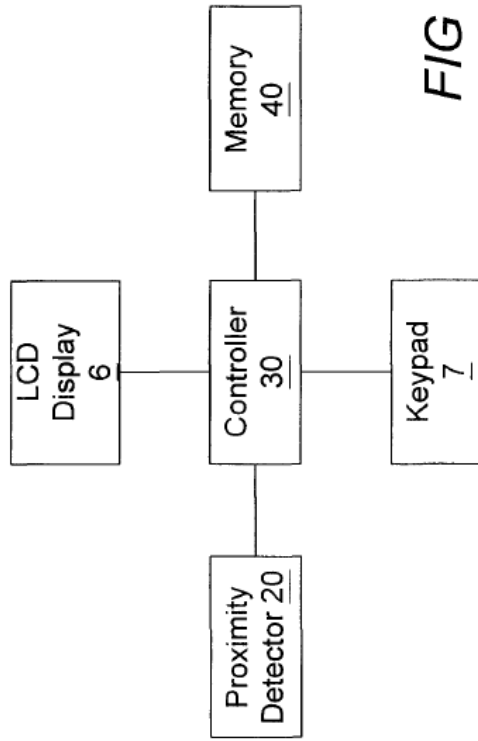

FIG 2

Sparre at Fig. 2.

“Together with the proximity detector 20, the controller 30 is arranged to bring the liquid crystal display 6 into its inactive state, whenever an external object is detected in proximity with the portion of the telephone 1, where the display is located. This functionality is referred to as Proximity Sleep Mode in the following.

According to one embodiment the man-machine interface of the mobile telephone 1 has an option for allowing the user to disable the Proximity Sleep Mode functionality, so that the display 6 is not turned off, even if an external object is detected by the proximity detector 20. The reason why the user should be given an opportunity to disable this feature is to prevent the display from accidentally being turned off, when the mobile telephone is carried in for instance a protective cover bag. Information regarding whether the Proximity Sleep Mode feature has been disabled by the user is preferably stored as a settings parameter in the memory 40.” Sparre at 11.

“If the answer of step 130 is in the affirmative, the controller 30 forces the liquid crystal display 6 to enter its inactive state in a subsequent step 150. As previously mentioned, the inactive state may either involve displaying only a limited set of icons (such as the remaining battery charge indicator 22), or completely turning off the liquid crystal display 6 by stop supplying electric energy to the liquid crystal layer. The first case is represented by a step 155b in FIG 3, whereas the second case is represented by steps 155a and 157a. Following the last step (i.e., either step 155b or step 157a) the control is transferred back to the beginning of routine 100. If, on the other hand, no external object has been detected in step 130, the controller 30 causes the liquid crystal display 6 to enter its active state, provided that the display 6 is not already active, in a step 140. When step 140 has been completed, the control is transferred back to the beginning of routine 100. In this way, an endless loop is formed by steps 100, 110, 120, 130, 140, 150 and 155b and 155a, 157a, respectively. Consequently, the presence of an external object in proximity with the proximity detector 20 will be continuously monitored, and in response to detecting such an external object, the display 6 will be set to its active state, thereby saving electric power. Furthermore, if the external object disappears from the proximity detector 20, the display 6 is again set to its active state in step 140.

Preferably, the endless Proximity Sleep Mode routine 100 may be interrupted by the controller 30 (pre-emptive scheduling) , so that other tasks with higher priority may be executed instead of routine 100. For instance, as soon as the controller 30 has detected that the user has started initiating an outgoing call, the routine 100 is temporarily stopped and the display 6 is activated, thereby avoiding an undesired situation where e.g. the hand or head of the user is accidentally detected by the proximity detector 20, while the telephone number to be called is entered on the keypad 7.” Sparre at 12-13.

“The invention may also be combined with known power preservation arrangements, such as automatically turning off the display backlighting after certain time, as described in previous sections.” Sparre at 13.

<p>[1b] a proximity sensor adapted to generate a signal indicative of proximity of an external object; and</p>	<p>Sparre discloses a proximity sensor adapted to generate a signal indicative of proximity of an external object.</p> <p>For example:</p> <p>“A portable electric apparatus (1) has a display (6) of the type comprising a liquid crystal layer. The display has an active state for presenting visual information in response to a supply of electric energy to the liquid crystal layer. The display also has an inactive state, in which less electric energy is supplied to the liquid crystal layer and less visual information consequently is presented. The apparatus (1) also has a proximity detector (20) for detecting the presence of an object in proximity with the apparatus and in response causing the display (6) to enter its inactive state.” Sparre at Abstract.</p> <p>“Therefore, when the proximity detector has detected the presence of the external object, the display may be powered off or present less visual information. More specifically, the purpose above has been achieved for a portable electric apparatus having a display of the type comprising a liquid crystal layer, wherein the display has an active state for presenting visual information in response to a supply of electric energy to the liquid crystal layer, and wherein the display also has an inactive state, in which less electric energy is supplied to the liquid crystal layer and less visual information consequently is presented, by the provision of a proximity detector for detecting the presence of an object in proximity with the apparatus and in response causing the display to enter its inactive state.</p> <p>The purpose has also been achieved through a method of preserving power for a portable electric apparatus having a display of the type comprising a liquid crystal layer, the display having an active state for presenting visual information in response to a supply of electric energy to the liquid crystal layer, the display also having an inactive state, in which less electric energy is supplied to the liquid crystal layer and less visual information consequently is presented, by the steps of determining whether an</p>
--	---

object is present in proximity with the apparatus, and, if so, causing the display to enter its inactive state.” Sparre at 6-7.

“A proximity detector is provided at the uppermost portion of the front surface of the telephone 1. In the embodiment shown in FIG 1, the proximity detector 20 is located immediately above the display 6 next to the speaker 4. However, the exact location of the proximity detector 20 is not critical but may be varied between many different positions, as long as the functional requirements specified below are satisfied.

In one embodiment, the proximity detector 20 is an IR (infrared) detector, which is arranged to emit infrared light from the front surface of the telephone 1 and is arranged to detect infrared light, that has been reflected from an external object located close to the upper portion of front surface of the telephone 1. Hence, as is generally known per se, the proximity detector 20 may measure the intensity of the reflected infrared light and in response determine whether any external object is present in proximity with the detector 20. By establishing a predetermined threshold for the fraction of infrared light reflected back to the proximity detector 20, it is possible to define a predetermined range, within which any external object will be detected by the proximity detector 20. Obviously, such a threshold will depend on i.a. the surface structure and material of the external object in question. However, such an issue is regarded nothing more than a practical parameter, which in an actual application will have to be tested, evaluated and determined by a skilled person. Proximity detectors as such are generally known and are commercially available on the market in large numbers .

According to an alternative embodiment, if the mobile telephone is equipped with an IR interface for wireless data communication with external devices (such as a handheld computer), the IR transmitter thereof may be used also for the purpose of transmitting IR light to be detected by the proximity detector 20.

Alternatively, the proximity detector 20 may operate by emitting and detecting visible light, by detecting thermal energy generated by the external object, or by detecting the external object by capacitive means." Sparre at 9-10.

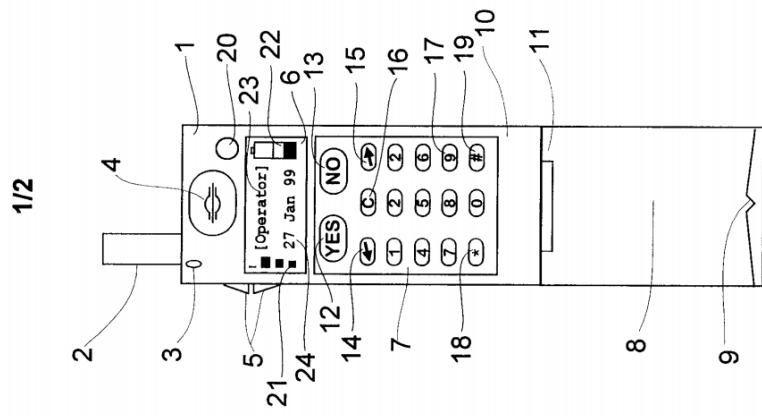

FIG 1

Sparre at Fig. 1.

“The main components of the mobile telephone 1 are shown in FIG 2. A controller 30 is operatively connected to the display 6, the keypad 7, the proximity detector 20 and a memory 40.” Sparre at 10.

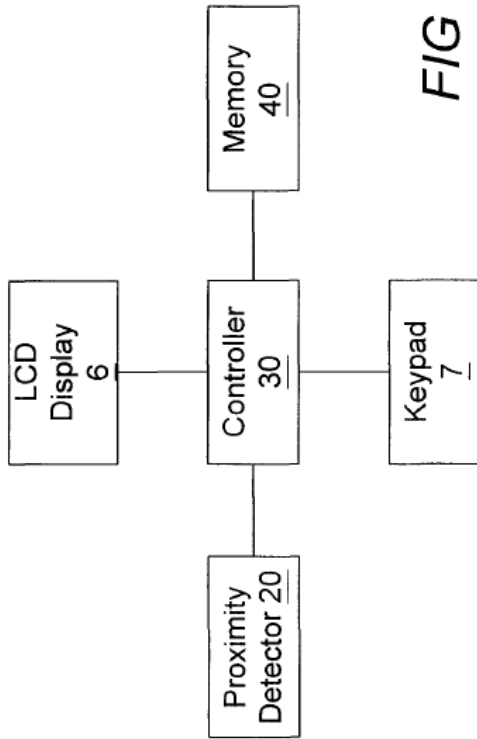

FIG 2

Sparre at Fig. 2.

“Together with the proximity detector 20, the controller 30 is arranged to bring the liquid crystal display 6 into its inactive state, whenever an external object is detected in proximity with the portion of the telephone 1, where the display is located. This functionality is referred to as Proximity Sleep Mode in the following.” Sparre at 11.

“FIG 3 illustrates a Proximity Sleep Mode routine 100, which according to one embodiment is regularly executed by the controller 30. After the initial step 100 the controller 30 determines, in step 110, whether the Proximity Sleep Mode feature has been disabled by the user. If the answer is in the affirmative, the control is immediately

returned to the beginning of routine 100. If, on the other hand, the Proximity Sleep Mode feature has not been disabled by the user, then the output from the proximity detector 20 is read in step 120. In step 130, the value of the output retrieved in step 120 is examined, so as to determine whether any external object is present in proximity with the proximity detector 20 and, consequently, the mobile telephone 1. Preferably, it is required in steps 120 and 130 that the presence of the external object is continuously detected for a certain period of time, before it is ultimately concluded that the display is indeed blocked by an external object. In this way, rapid hand movements, etc., past the display will not accidentally turn off the display.

If the answer of step 130 is in the affirmative, the controller 30 forces the liquid crystal display 6 to enter its inactive state in a subsequent step 150. As previously mentioned, the inactive state may either involve displaying only a limited set of icons (such as the remaining battery charge indicator 22), or completely turning off the liquid crystal display 6 by stop supplying electric energy to the liquid crystal layer. The first case is represented by a step 155b in FIG 3, whereas the second case is represented by steps 155a and 157a. Following the last step (i.e., either step 155b or step 157a) the control is transferred back to the beginning of routine 100. If, on the other hand, no external object has been detected in step 130, the controller 30 causes the liquid crystal display 6 to enter its active state, provided that the display 6 is not already active, in a step 140. When step 140 has been completed, the control is transferred back to the beginning of routine 100. In this way, an endless loop is formed by steps 100, 110, 120, 130, 140, 150 and 155b and 155a, 157a, respectively. Consequently, the presence of an external object in proximity with the proximity detector 20 will be continuously monitored, and in response to detecting such an external object, the display 6 will be set to its active state, thereby saving electric power. Furthermore, if the external object disappears from the proximity detector 20, the display 6 is again set to its active state in step 140." Sparre at 11-13.

"1. A portable electric apparatus (1) having a display (6) of the type comprising a liquid crystal, the display having an active state for presenting visual information in response to a supply of electric energy to the liquid crystal layer, the display also having an

	<p>inactive state, in which less electric energy is supplied to the liquid crystal layer and less visual information consequently is presented, characterized by a proximity detector (20) for detecting the presence of an object in proximity with the apparatus (1) and in response causing the display (6) to enter its inactive state.</p> <p>2. A portable electric apparatus (1) according to claim 1, wherein the proximity detector (20) operates by detecting infrared (IR) light.</p> <p>3. A portable electric apparatus (1) according to claim 1, wherein the proximity detector (20) operates by detecting visible light .</p> <p>4. A portable electric apparatus (1) according to claim 1, wherein the proximity detector (20) operates by detecting thermal energy generated by said object.</p> <p>5. A portable electric apparatus (1) according to claim 1, wherein the proximity detector (20) operates by detecting said object by capacitive means.” Sparre at Claims 1-5.</p> <p>“11. A method of preserving power for a portable electric apparatus (1) having a display (6) of the type comprising a liquid crystal layer, the display having an active state for presenting visual information in response to a supply of electric energy to the liquid crystal layer, the display also having an inactive state, in which less electric energy is supplied to the liquid crystal layer and less visual information consequently is presented, characterized by the steps of determining whether an object is present in proximity with the apparatus (1) , and, if so, causing the display (6) to enter its inactive state.” Sparre at Claim 11.</p>
<p>[1c] a microprocessor adapted to:</p>	<p>Sparre discloses a microprocessor.</p> <p>For example:</p>

“The main components of the mobile telephone 1 are shown in FIG 2. A controller 30 is operatively connected to the display 6, the keypad 7, the proximity detector 20 and a memory 40. The controller 30 may be any microprocessor, central processing unit (CPU) or other piece of electronic logic circuitry already used in the telephone 1 for performing the various functions thereof (such as telephone call control, keypad control, display control, or execution of utility programs such as a calculator program, electronic game programs, etc) . Alternatively, the controller 30 may be realized by separate electronic logic circuitry, which in itself is generally known, such as a microprocessor, an integrated circuit network, etc. Correspondingly, the memory 40 may be of any type generally known within the field of portable electric apparatuses, such as an EEPROM memory, a RAM memory, a flash memory etc.” Sparre at 10-11.

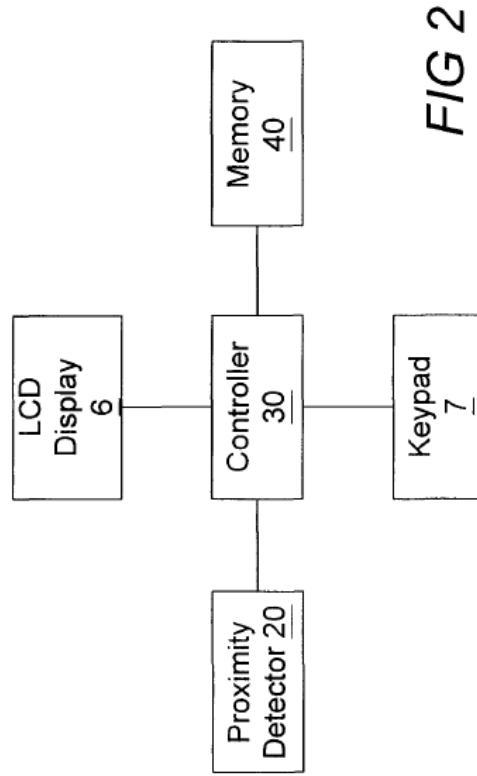

Sparre at Fig. 2.

<p>[1d] (a) determine whether a telephone call is active;</p>	<p>FIG 3 illustrates a Proximity Sleep Mode routine 100, which according to one embodiment is regularly executed by the controller 30. Sparre at 11.</p>
<p>Sparre discloses the microprocessor adapted to determine whether a telephone call is active.</p> <p>For example: “</p> <p>“A portable electric apparatus (1) has a display (6) of the type comprising a liquid crystal layer. The display has an active state for presenting visual information in response to a supply of electric energy to the liquid crystal layer. The display also has an inactive state, in which less electric energy is supplied to the liquid crystal layer and less visual information consequently is presented. The apparatus (1) also has a proximity detector (20) for detecting the presence of an object in proximity with the apparatus and in response causing the display (6) to enter its inactive state.” Sparre at Abstract.</p> <p>“The present invention relates to a portable electric apparatus having a display of the type comprising a liquid crystal layer, the display having an active state for presenting visual information in response to a supply of electric energy to the liquid crystal layer, the display also having an inactive state, in which less electric energy is supplied to the liquid crystal layer and less visual information consequently is presented. More specifically, the invention is directed at a new and inventive way of preserving electric power in such a portable electric apparatus by bringing the display to its inactive state whenever appropriate. The invention also relates to a method of preserving power for such an apparatus.” Sparre at 1.</p> <p>“The highest power consumption for a liquid crystal display occurs when an event takes place in the telephone, for instance when a telephone call is generated or ended. In those situations, the visibility of the LCD display is amplified by turning on a back-light illumination of the display. Such back-light illumination consumes too much</p>	<p>Sparre discloses the microprocessor adapted to determine whether a telephone call is active.</p> <p>For example: “</p> <p>“A portable electric apparatus (1) has a display (6) of the type comprising a liquid crystal layer. The display has an active state for presenting visual information in response to a supply of electric energy to the liquid crystal layer. The display also has an inactive state, in which less electric energy is supplied to the liquid crystal layer and less visual information consequently is presented. The apparatus (1) also has a proximity detector (20) for detecting the presence of an object in proximity with the apparatus and in response causing the display (6) to enter its inactive state.” Sparre at Abstract.</p> <p>“The present invention relates to a portable electric apparatus having a display of the type comprising a liquid crystal layer, the display having an active state for presenting visual information in response to a supply of electric energy to the liquid crystal layer, the display also having an inactive state, in which less electric energy is supplied to the liquid crystal layer and less visual information consequently is presented. More specifically, the invention is directed at a new and inventive way of preserving electric power in such a portable electric apparatus by bringing the display to its inactive state whenever appropriate. The invention also relates to a method of preserving power for such an apparatus.” Sparre at 1.</p> <p>“The highest power consumption for a liquid crystal display occurs when an event takes place in the telephone, for instance when a telephone call is generated or ended. In those situations, the visibility of the LCD display is amplified by turning on a back-light illumination of the display. Such back-light illumination consumes too much</p>

power than what is acceptable in a long-term perspective. Therefore, back- light illumination is normally restricted to a short time period of a few seconds around the respective event, such as the entering of a telephone number on the keypad, the reception of an incoming call or the termination of an ongoing call (on-hook).” Sparre at 3.

“US-A-5 881 377 discloses a radio telephone with a power-saving arrangement, which is adapted to detect the presence of the radio telephone in proximity with an ear of a user and which also is adapted to turn off a display of the radio telephone. Aforesaid arrangement may be of a type capable of detecting heat, or comprise an opto-electric switch. The display of the radio telephone is of a type comprising light emitting diodes (LED). According to an alternative embodiment of US-A-5 881 377, the display is a liquid crystal display, and a light emitting diode is provided for backlighting the LCD-display. In this embodiment, the backlighting LED, but not the actual liquid crystal display, is switched on and off for saving electric power in response to whether or not the radio telephone is kept near the user’s head.” Sparre at 5.

The purpose of these inventions is to save electric power when the telephone is kept close to the user (i.e. in proximity with the user’s ear in talking position).” Sparre at 6.

“A foldable flip 8 is swingably mounted to the apparatus housing 10 by means of a hinge mechanism 11. The flip 8 comprises a sound opening 9, through which vocal sound is received from the user of the telephone and forwarded to an internal microphone (not shown in the drawing).” Sarre at 9.

“The controller 30 may be any microprocessor, central processing unit (CPU) or other piece of electronic logic circuitry already used in the telephone 1 for performing the

various functions thereof (such as telephone call control, keypad control, display control, or execution of utility programs such as a calculator program, electronic game programs, etc).” Sparre at 10-11.

“Preferably, the endless Proximity Sleep Mode routine 100 may be interrupted by the controller 30 (pre-emptive scheduling), so that other tasks with higher priority may be executed instead of routine 100. For instance, as soon as the controller 30 has detected that the user has started initiating an outgoing call, the routine 100 is temporarily stopped and the display 6 is activated, thereby avoiding an undesired situation where e.g. the hand or head of the user is accidentally detected by the proximity detector 20, while the telephone number to be called is entered on the keypad 7.

Correspondingly, routine 100 may be temporarily aborted upon detection of an incoming telephone call, text message (SMS; Short Messages Services), etc.” Sparre at 13.

“The invention may also be combined with known power preservation arrangements, such as automatically turning off the display backlighting after certain time, as described in previous sections.” Sparre at 13.

“10. A portable electric apparatus (1) according to any preceding claim, wherein the apparatus is a telecommunication device, preferably a mobile telephone (1).” Sparre at claim 10.

“12. A method according to claim 11, comprising an initial step of determining whether a user of the apparatus has chosen to disable the execution of the steps in claim 11, wherein the steps of claim 12 are only executed, if no such choice has been made by the user.” Sparre at claim 11.

To the extent Sparre is deemed to not expressly disclose the microprocessor adapted to “determine whether a telephone call is active,” Sparre inherently discloses this limitation. For example, Sparre discloses that the normal routine of detecting via the proximity sensor can be temporarily halted by the microprocessor under certain circumstances such as detecting that the user is dialing a number. *See* Sparre at 13 (“Preferably, the endless Proximity Sleep Mode routine 100 may be interrupted by the controller 30 (pre-emptive scheduling), so that other tasks with higher priority may be executed instead of routine 100. For instance, as soon as the controller 30 has detected that the user has started initiating an outgoing call, the routine 100 is temporarily stopped and the display 6 is activated, thereby avoiding an undesired situation where e.g. the hand or head of the user is accidentally detected by the proximity detector 20, while the telephone number to be called is entered on the keypad 7. Correspondingly, routine 100 may be temporarily aborted upon detection of an incoming telephone call, text message (SMS; Short Messages Services), etc.”). A person of ordinary skill in the art at the time of the alleged invention would understand that since Sparre teaches that the microprocessor only temporarily halts the normal routine, the microprocessor would necessarily need to be able “determine whether a telephone call is active” in order to determine the appropriate time to start up the normal routine again. A person of ordinary skill in the art at the time of the alleged invention would have such understanding because they would for example, further understand that once the user of the mobile station is done initiating the outgoing call by dialing keys on the handset they will place the handset next to their head for the duration of the call at which time the proximity detector 20 of Sparre would need to be functioning in order to signal to the microprocessor that the display should be powered down in order for the battery conservation purpose of Sparre to be realized. Therefore, a person of ordinary skill in

the art at the time of the alleged invention would understand that necessarily the microprocessor would “determine whether a telephone call is active.”

To the extent Sparre is deemed to not expressly or inherently disclose the microprocessor adapted to “determine whether a telephone call is active,” Sparre renders it obvious to one of skill in the art to “determine whether a telephone call is active.” For example, Sparre discloses that the normal routine of detecting via the proximity sensor can be temporarily halted by the microprocessor under certain circumstances such as detecting that the user is dialing a number. *See* Sparre at 13 (“Preferably, the endless Proximity Sleep Mode routine 100 may be interrupted by the controller 30 (pre-emptive scheduling), so that other tasks with higher priority may be executed instead of routine 100. For instance, as soon as the controller 30 has detected that the user has started initiating an outgoing call, the routine 100 is temporarily stopped and the display 6 is activated, thereby avoiding an undesired situation where e.g. the hand or head of the user is accidentally detected by the proximity detector 20, while the telephone number to be called is entered on the keypad 7. Correspondingly, routine 100 may be temporarily aborted upon detection of an incoming telephone call, text message (SMS; Short Messages Services), etc.”). A person of ordinary skill in the art at the time of the alleged invention would understand that since Sparre teaches that the microprocessor only temporarily halts the normal routine, the microprocessor would need to be able “determine whether a telephone call is active” in order to determine the appropriate time to start up the normal routine again. A person of ordinary skill in the art at the time of the alleged invention would have such understanding because they would for example, further understand that once the user of the mobile station is done initiating the outgoing call by dialing keys on the handset they will place the handset next to their head for the duration of the call at which time the proximity detector 20 of Sparre would need to be functioning in order to signal to the microprocessor that the display should be powered down in order for the battery conservation purpose of Sparre to be realized. It would therefore be obvious to one of ordinary skill in the art at the time of the alleged invention that the microprocessor of Sparre be modified to “determine whether a telephone call is active.” Doing so would be within the skill of one of ordinary skill in the art, and would constitute, at

least, combining prior art elements according to known methods to yield predictable results, a simple substitution of one known element for another to obtain predictable results, the use of a known technique to improve similar devices in the same way, the application of a known technique to a known device ready for improvement to yield a predictable result, and obvious to try.

To the extent Sparre is deemed to not expressly or inherently disclose a microprocessor adapted to “determine whether a telephone call is active,” it would be obvious to combine the disclosure of Sparre with those of Fukiharu 598 as described in the Fukiharu 598 claim chart, which is incorporated herein in its entirety by reference. Sparre and Fukiharu 598 are both directed to conserving battery power in mobile stations generally and more particularly at conserving battery power in mobile stations by using sensors to detect when the user of the mobile station is in a call and unlikely to be looking at the display (as when, for example, the proximity sensor detects the user’s ear by the mobile station) and to power off the display of mobile stations at such times. Sparre at 6 (“The purpose of the present invention is to propose an improved solution to the problem of preserving electric power in a portable electric apparatus having a liquid crystal display. In particular, the invention aims at achieving such power preservation at a lower cost and with improved accuracy, as compared to the prior art solutions. According to the invention, the portable electric apparatus is provided with a proximity detector, which is arranged to detect when an external object is very close to a specific portion of the apparatus (for instance less than 3 cm from the display). The external object may be the user’s ear (when the telephone is held in a normal position for conversation), or the interior walls of a pocket or bag, in which the telephone has been placed by the user. In all circumstances, the presence of such an external object indicates that the apparatus is not in a position, where it is useful to keep the display turned on, since the user is physically prevented from visual access to the display. Therefore, when the proximity detector has detected the presence of the external object, the display may be powered off or present less visual information.”); Fukiharu 598 at ¶ 0018 (“The present invention, through the use of a structure as described above, enables a reduction in the consumption of battery power, through enabling the lighting devices to be turned

	<p>OFF when the ear is caused to contact the receiver portion in order to hear the receiver sound during voice communications of a mobile telephone when the lighting devices (backlights) for a liquid crystal display device and keypad portion of a mobile telephone are lit, such as that night.”). A person of ordinary skill in the art at the time of the alleged invention would be motivated to modify Sparre to use “a microprocessor adapted to...determine whether a telephone call is active,” as disclosed in Fukiharu 598 for a number of different reasons, including that it would support Sparre’s ability to conserve battery power in mobile stations, and doing so would be within the knowledge and ability of a person of ordinary skill in the art at the time of the alleged invention. The combination would constitute, at least, combining prior art elements according to known methods to yield predictable results, a simple substitution of one known element for another to obtain predictable results, the use of a known technique to improve similar devices in the same way, the application of a known technique to a known device ready for improvement to yield a predictable result, and obvious to try.</p>
<p>[1e] (b) receive the signal from the proximity sensor; and</p>	<p>Sparre discloses the microprocessor adapted to receive the signal from the proximity sensor.</p> <p>For example: “A portable electric apparatus (1) has a display (6) of the type comprising a liquid crystal layer. The display has an active state for presenting visual information in response to a supply of electric energy to the liquid crystal layer. The display also has an inactive state, in which less electric energy is supplied to the liquid crystal layer and less visual information consequently is presented. The apparatus (1) also has a proximity detector (20) for detecting the presence of an object in proximity with the apparatus and in response causing the display (6) to enter its inactive state.” Sparre at Abstract.</p> <p>“Therefore, when the proximity detector has detected the presence of the external object, the display may be powered off or present less visual information. More specifically, the purpose above has been achieved for a portable electric apparatus</p>

having a display of the type comprising a liquid crystal layer, wherein the display has an active state for presenting visual information in response to a supply of electric energy to the liquid crystal layer, and wherein the display also has an inactive state, in which less electric energy is supplied to the liquid crystal layer and less visual information consequently is presented, by the provision of a proximity detector for detecting the presence of an object in proximity with the apparatus and in response causing the display to enter its inactive state.

The purpose has also been achieved through a method of preserving power for a portable electric apparatus having a display of the type comprising a liquid crystal layer, the display having an active state for presenting visual information in response to a supply of electric energy to the liquid crystal layer, the display also having an inactive state, in which less electric energy is supplied to the liquid crystal layer and less visual information consequently is presented, by the steps of determining whether an object is present in proximity with the apparatus, and, if so, causing the display to enter its inactive state.” Sparre at 6-7.

“A proximity detector is provided at the uppermost portion of the front surface of the telephone 1. In the embodiment shown in FIG 1, the proximity detector 20 is located immediately above the display 6 next to the speaker 4. However, the exact location of the proximity detector 20 is not critical but may be varied between many different positions, as long as the functional requirements specified below are satisfied.

In one embodiment, the proximity detector 20 is an IR (infrared) detector, which is arranged to emit infrared light from the front surface of the telephone 1 and is arranged to detect infrared light, that has been reflected from an external object located close to the upper portion of front surface of the telephone 1. Hence, as is generally known per se, the proximity detector 20 may measure the intensity of the reflected infrared light and in response determine whether any external object is present in proximity with the detector 20. By establishing a predetermined threshold for the fraction of infrared light reflected back to the proximity detector 20, it is possible to define a predetermined range, within which any external object will be detected by the proximity detector 20. Obviously, such a threshold will depend on i.a. the surface

structure and material of the external object in question. However, such an issue is regarded nothing more than a practical parameter, which in an actual application will have to be tested, evaluated and determined by a skilled person. Proximity detectors as such are generally known and are commercially available on the market in large numbers .

According to an alternative embodiment, if the mobile telephone is equipped with an IR interface for wireless data communication with external devices (such as a handheld computer) , the IR transmitter thereof may be used also for the purpose of transmitting IR light to be detected by the proximity detector 20.

Alternatively, the proximity detector 20 may operate by emitting and detecting visible light, by detecting thermal energy generated by the external object, or by detecting the external object by capacitive means.

The main components of the mobile telephone 1 are shown in FIG 2. A controller 30 is operatively connected to the display 6, the keypad 7, the proximity detector 20 and a memory 40. The controller 30 may be any microprocessor, central processing unit (CPU) or other piece of electronic logic circuitry already used in the telephone 1 for performing the various functions thereof (such as telephone call control, keypad control, display control, or execution of utility programs such as a calculator program, electronic game programs, etc) . Alternatively, the controller 30 may be realized by separate electronic logic circuitry, which in itself is generally known, such as a microprocessor, an integrated circuit network, etc. Correspondingly, the memory 40 may be of any type generally known within the field of portable electric apparatuses, such as an EEPROM memory, a RAM memory, a flash memory etc.

Together with the proximity detector 20, the controller 30 is arranged to bring the liquid crystal display 6 into its inactive state, whenever an external object is detected in proximity with the portion of the telephone 1, where the display is located. This functionality is referred to as Proximity Sleep Mode in the following.” Sparre at 9-11.

1/2

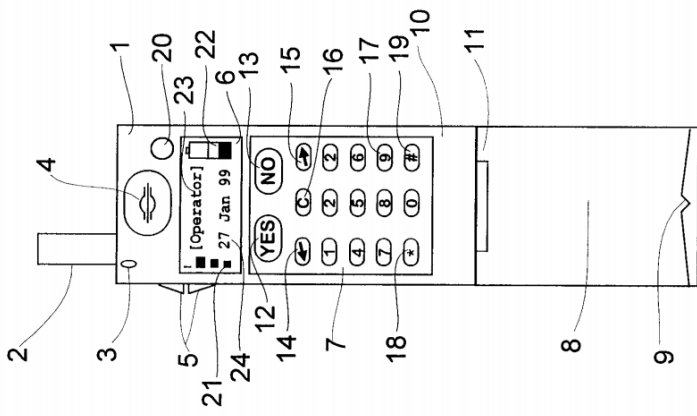

FIG 1

Sparre at Fig. 1.

“The main components of the mobile telephone 1 are shown in FIG 2. A controller 30 is operatively connected to the display 6, the keypad 7, the proximity detector 20 and a memory 40.” Sparre at 10.

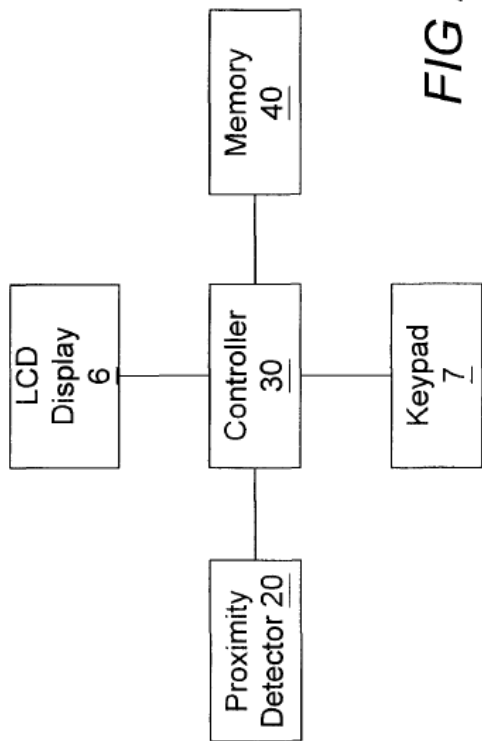

FIG 2

Sparre at Fig. 2.

“FIG 3 illustrates a Proximity Sleep Mode routine 100, which according to one embodiment is regularly executed by the controller 30. After the initial step 100 the controller 30 determines, in step 110, whether the Proximity Sleep Mode feature has been disabled by the user. If the answer is in the affirmative, the control is immediately returned to the beginning of routine 100. If, on the other hand, the Proximity Sleep Mode feature has not been disabled by the user, then the output from the proximity detector 20 is read in step 120. In step 130, the value of the output retrieved in step 120 is examined, so as to determine whether any external object is present in proximity with the proximity detector 20 and, consequently, the mobile telephone 1. Preferably, it is required in steps 120 and 130 that the presence of the external object is continuously detected for a certain period of time, before it is ultimately concluded that the display is indeed blocked by an external object. In this way, rapid hand movements, etc., past the display will not accidentally turn off the display.

If the answer of step 130 is in the affirmative, the controller 30 forces the liquid crystal display 6 to enter its inactive state in a subsequent step 150. As previously mentioned,

the inactive state may either involve displaying only a limited set of icons (such as the remaining battery charge indicator 22), or completely turning off the liquid crystal display 6 by stop supplying electric energy to the liquid crystal layer. The first case is represented by a step 155b in FIG 3, whereas the second case is represented by steps 155a and 157a. Following the last step (i.e., either step 155b or step 157a) the control is transferred back to the beginning of routine 100. If, on the other hand, no external object has been detected in step 130, the controller 30 causes the liquid crystal display 6 to enter its active state, provided that the display 6 is not already active, in a step 140. When step 140 has been completed, the control is transferred back to the beginning of routine 100. In this way, an endless loop is formed by steps 100, 110, 120, 130, 140, 150 and 155b and 157a, respectively. Consequently, the presence of an external object in proximity with the proximity detector 20 will be continuously monitored, and in response to detecting such an external object, the display 6 will be set to its active state, thereby saving electric power. Furthermore, if the external object disappears from the proximity detector 20, the display 6 is again set to its active state in step 140." Sparre at 11-13.

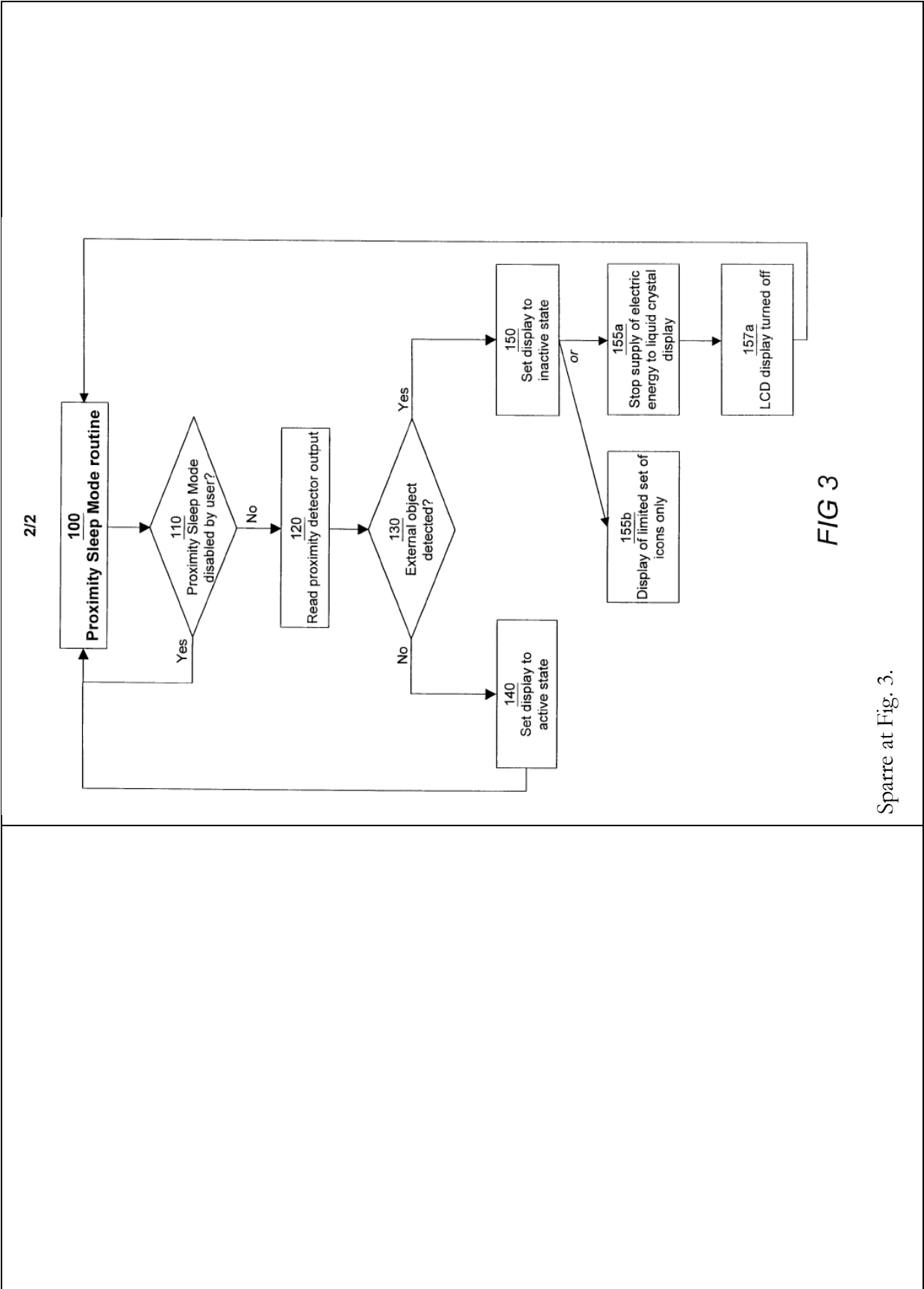

	<p>“1. A portable electric apparatus (1) having a display (6) of the type comprising a liquid crystal, the display having an active state for presenting visual information in response to a supply of electric energy to the liquid crystal layer, the display also having an inactive state, in which less electric energy is supplied to the liquid crystal layer and less visual information consequently is presented, characterized by a proximity detector (20) for detecting the presence of an object in proximity with the apparatus (1) and in response causing the display (6) to enter its inactive state.” Sparre at claim 1.</p> <p>“11. A method of preserving power for a portable electric apparatus (1) having a display (6) of the type comprising a liquid crystal layer, the display having an active state for presenting visual information in response to a supply of electric energy to the liquid crystal layer, the display also having an inactive state, in which less electric energy is supplied to the liquid crystal layer and less visual information consequently is presented, characterized by the steps of determining whether an object is present in proximity with the apparatus (1) , and, if so, causing the display (6) to enter its inactive state.” Sparre at claim 11.</p>
<p>[1f] (c) reduce power to the display if (i) the microprocessor determines that a telephone call is active and (ii) the signal indicates the proximity of the external object; wherein:</p>	<p>Sparre discloses the microprocessor adapted to reduce power to the display if (i) the microprocessor determines that a telephone call is active and (ii) the signal indicates the proximity of the external object.</p> <p>For example: <i>see</i> discussions of claim elements [1b], [1d], [1e], <i>supra</i>, which are incorporated herein by reference.</p> <p>“A portable electric apparatus (1) has a display (6) of the type comprising a liquid crystal layer. The display has an active state for presenting visual information in response to a supply of electric energy to the liquid crystal layer. The display also has</p>

an inactive state, in which less electric energy is supplied to the liquid crystal layer and less visual information consequently is presented. The apparatus (1) also has a proximity detector (20) for detecting the presence of an object in proximity with the apparatus and in response causing the display (6) to enter its inactive state.” Sparre at Abstract.

“Therefore, when the proximity detector has detected the presence of the external object, the display may be powered off or present less visual information. More specifically, the purpose above has been achieved for a portable electric apparatus having a display of the type comprising a liquid crystal layer, wherein the display has an active state for presenting visual information in response to a supply of electric energy to the liquid crystal layer, and wherein the display also has an inactive state, in which less electric energy is supplied to the liquid crystal layer and less visual information consequently is presented, by the provision of a proximity detector for detecting the presence of an object in proximity with the apparatus and in response causing the display to enter its inactive state.

The purpose has also been achieved through a method of preserving power for a portable electric apparatus having a display of the type comprising a liquid crystal layer, the display having an active state for presenting visual information in response to a supply of electric energy to the liquid crystal layer, the display also having an inactive state, in which less electric energy is supplied to the liquid crystal layer and less visual information consequently is presented, by the steps of determining whether an object is present in proximity with the apparatus, and, if so, causing the display to enter its inactive state.” Sparre at 6-7.

“The main components of the mobile telephone 1 are shown in FIG 2. A controller 30 is operatively connected to the display 6, the keypad 7, the proximity detector 20 and a memory 40. The controller 30 may be any microprocessor, central processing unit (CPU) or other piece of electronic logic circuitry already used in the telephone 1 for performing the various functions thereof (such as telephone call control, keypad

control, display control, or execution of utility programs such as a calculator program, electronic game programs, etc) . Alternatively, the controller 30 may be realized by separate electronic logic circuitry, which in itself is generally known, such as a microprocessor, an integrated circuit network, etc. Correspondingly, the memory 40 may be of any type generally known within the field of portable electric apparatuses, such as an EEPROM memory, a RAM memory, a flash memory etc.

Together with the proximity detector 20, the controller 30 is arranged to bring the liquid crystal display 6 into its inactive state, whenever an external object is detected in proximity with the portion of the telephone 1, where the display is located. This functionality is referred to as Proximity Sleep Mode in the following.” Sparre at 10-11.

1/2

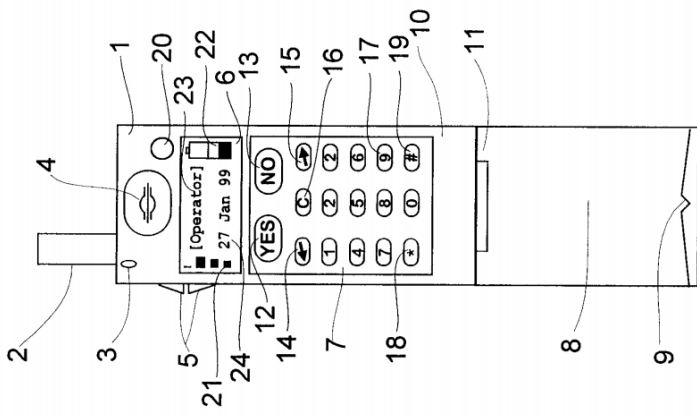

FIG 1

Sparre at Fig. 1.

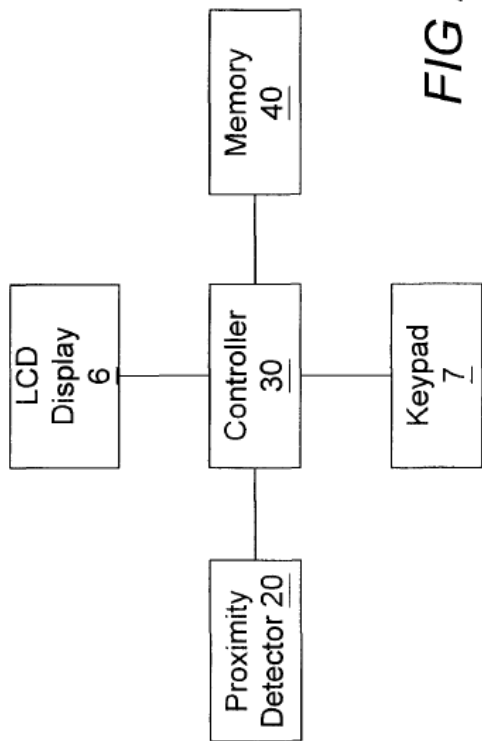

FIG 2

Sparre at Fig. 2.

“Together with the proximity detector 20, the controller 30 is arranged to bring the liquid crystal display 6 into its inactive state, whenever an external object is detected in proximity with the portion of the telephone 1, where the display is located. This functionality is referred to as Proximity Sleep Mode in the following.

According to one embodiment the man-machine interface of the mobile telephone 1 has an option for allowing the user to disable the Proximity Sleep Mode functionality, so that the display 6 is not turned off, even if an external object is detected by the proximity detector 20. The reason why the user should be given an opportunity to disable this feature is to prevent the display from accidentally being turned off, when the mobile telephone is carried in for instance a protective cover bag. Information regarding whether the Proximity Sleep Mode feature has been disabled by the user is preferably stored as a settings parameter in the memory 40.

FIG 3 illustrates a Proximity Sleep Mode routine 100, which according to one embodiment is regularly executed by the controller 30. After the initial step 100 the

<p>controller 30 determines, in step 110, whether the Proximity Sleep Mode feature has been disabled by the user. If the answer is in the affirmative, the control is immediately returned to the beginning of routine 100. If, on the other hand, the Proximity Sleep Mode feature has not been disabled by the user, then the output from the proximity detector 20 is read in step 120. In step 130, the value of the output retrieved in step 120 is examined, so as to determine whether any external object is present in proximity with the proximity detector 20 and, consequently, the mobile telephone 1. Preferably, it is required in steps 120 and 130 that the presence of the external object is continuously detected for a certain period of time, before it is ultimately concluded that the display is indeed blocked by an external object. In this way, rapid hand movements, etc., past the display will not accidentally turn off the display.</p> <p>If the answer of step 130 is in the affirmative, the controller 30 forces the liquid crystal display 6 to enter its inactive state in a subsequent step 150. As previously mentioned, the inactive state may either involve displaying only a limited set of icons (such as the remaining battery charge indicator 22), or completely turning off the liquid crystal display 6 by stop supplying electric energy to the liquid crystal layer. The first case is represented by a step 155b in FIG 3, whereas the second case is represented by steps 155a and 157a. Following the last step (i.e., either step 155b or step 157a) the control is transferred back to the beginning of routine 100. If, on the other hand, no external object has been detected in step 130, the controller 30 causes the liquid crystal display 6 to enter its active state, provided that the display 6 is not already active, in a step 140. When step 140 has been completed, the control is transferred back to the beginning of routine 100. In this way, an endless loop is formed by steps 100, 110, 120, 130, 140, 150 and 155b and 157a, respectively. Consequently, the presence of an external object in proximity with the proximity detector 20 will be continuously monitored, and in response to detecting such an external object, the display 6 will be set to its active state, thereby saving electric power. Furthermore, if the external object disappears from the proximity detector 20, the display 6 is again set to its active state in step 140.</p> <p>Preferably, the endless Proximity Sleep Mode routine 100 may be interrupted by the controller 30 (pre-emptive scheduling), so that other tasks with higher priority may be executed instead of routine 100. For instance, as soon as the controller 30 has detected</p>	
---	--

that the user has started initiating an outgoing call, the routine 100 is temporarily stopped and the display 6 is activated, thereby avoiding an undesired situation where e.g. the hand or head of the user is accidentally detected by the proximity detector 20, while the telephone number to be called is entered on the keypad 7.

Correspondingly, routine 100 may be temporarily aborted upon detection of an incoming telephone call, text message (SMS; Short Messages Services), etc.” Sparre 11-13.

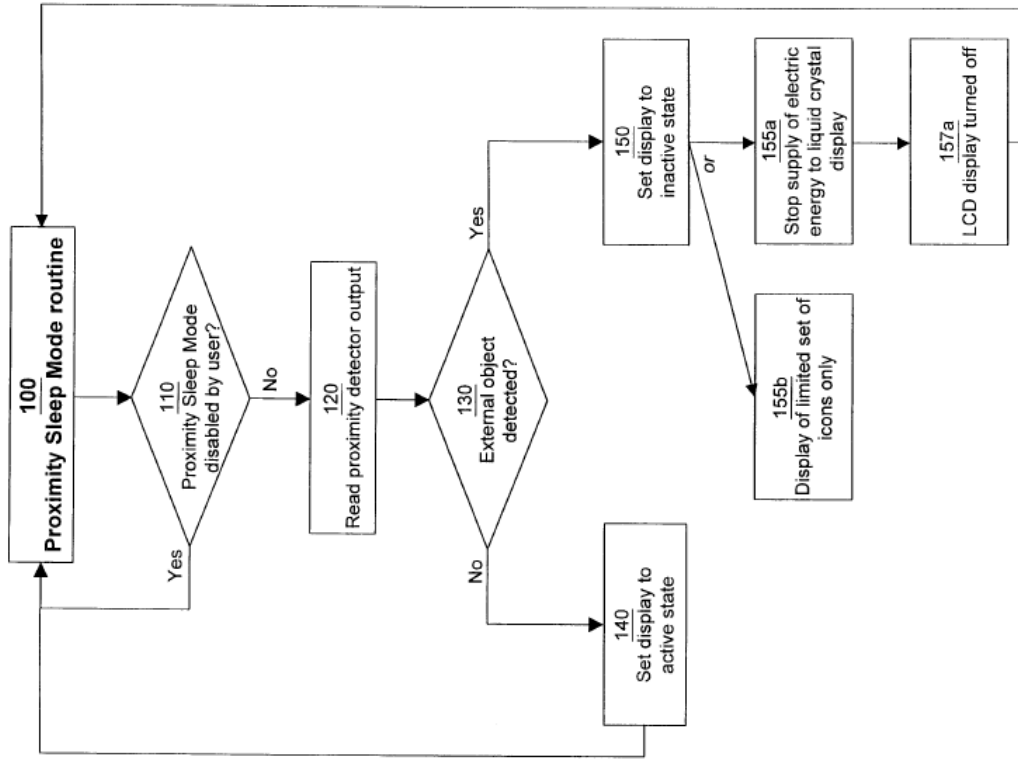

FIG 3

Sparre at Fig. 3.

“1. A portable electric apparatus (1) having a display (6) of the type comprising a liquid crystal, the display having an active state for presenting visual information in response to a supply of electric energy to the liquid crystal layer, the display also having an inactive state, in which less electric energy is supplied to the liquid crystal layer and less visual information consequently is presented, characterized by a proximity detector (20) for detecting the presence of an object in proximity with the apparatus (1) and in response causing the display (6) to enter its inactive state.” Sparre at claim 1.

“8. A portable electric apparatus (1) according to any preceding claim, wherein the display (6) is arranged, in its active state, to present a plurality of graphical symbols or icons and wherein the display (6) , in its inactive state, is arranged to present only some of said plurality of graphical symbols or icons.

9. A portable electric apparatus (1) according to any of claims 1-7, wherein the inactive state of the display

(6) is a state, where the display is electrically turned off.” Sparre at claims 8-9.

“11. A method of preserving power for a portable electric apparatus (1) having a display (6) of the type comprising a liquid crystal layer, the display having an active state for presenting visual information in response to a supply of electric energy to the liquid crystal layer, the display also having an inactive state, in which less electric energy is supplied to the liquid crystal layer and less visual information consequently is presented, characterized by the steps of determining whether an object is present in proximity with the apparatus (1) , and, if so, causing the display (6) to enter its inactive state.” Sparre at claim 11.

“12. A method according to claim 11, comprising an initial step of determining whether a user of the apparatus has chosen to disable the execution of the steps in claim 11, wherein the steps of claim 12 are only executed, if no such choice has been made by the user.” Sparre at claim 12.

To the extent Sparre is deemed to not disclose the microprocessor adapted to “reduce power to the display if (i) the microprocessor determines that a telephone call is active and (ii) the signal indicates the proximity of the external object,” Sparre renders this limitation obvious to one of skill in the art. Sparre “is directed at a new and inventive way of preserving electric power in such a portable electric apparatus by bringing the display to its inactive state whenever appropriate. Sparre at 1. Sparre discloses that “apparatus (1) also has a proximity detector (20) for detecting the presence of an object in proximity with the apparatus and in response causing the display (6) to enter its inactive state.” Sparre at Abstract. Also, as set forth in the discussion of claim element [1d], *supra*, Sparre discloses determining whether a telephone call is active. In order to further Sparre’s stated goal of conserving battery power in a mobile telephone, it would be obvious to a person of skill in the art to modify Sparre’s microprocessor to reduce power to the display if the controller (comprising a microprocessor, *see* Sparre at 10) determines that a telephone call is active, and thus “reduce power to the display if (i) the microprocessor determines that a telephone call is active and (ii) the signal indicates the proximity of the external object.”

To the extent Sparre is deemed to not expressly disclose the microprocessor adapted to “(c) reduce power to the display if (i) the microprocessor determines that a telephone call is active and (ii) the signal indicates the proximity of the external object,” Mantyjärvi inherently discloses this limitation or renders it obvious to a person of ordinary skill in the art at the time of the alleged invention for the reasons described in claim element [1h], *infra*, incorporate herein by reference.

Sparre discloses the telephone call as a wireless telephone call.

[1g] the telephone call is a wireless telephone call;

For example: *see* discussion of claim element 1[d], *supra*, which is incorporated herein by reference.

“The highest power consumption for a liquid crystal display occurs when an event takes place in the telephone, for instance when a telephone call is generated or ended. In those situations, the visibility of the LCD display is amplified by turning on a back-light illumination of the display. Such back-light illumination consumes too much power than what is acceptable in a long-term perspective. Therefore, back-light illumination is normally restricted to a short time period of a few seconds around the respective event, such as the entering of a telephone number on the keypad, the reception of an incoming call or the termination of an ongoing call (on-hook).” Sparre at 3.”

“US-A-5 881 377 discloses a radio telephone with a power-saving arrangement, which is adapted to detect the presence of the radio telephone in proximity with an ear of a user and which also is adapted to turn off a display of the radio telephone. Aforesaid arrangement may be of a type capable of detecting heat, or comprise an opto-electric switch. The display of the radio telephone is of a type comprising light emitting diodes (LED). According to an alternative embodiment of US-A-5 881 377, the display is a liquid crystal display, and a light emitting diode is provided for backlighting the LCD-display. In this embodiment, the backlighting LED, but not the actual liquid crystal display, is switched on and off for saving electric power in response to whether or not the radio telephone is kept near the user's head.” Sparre at 5.”

“An example of a portable electric apparatus is given in FIG 1 in the form of a mobile telephone 1 having a housing 10, an antenna 2 mounted on top of the housing, a status indicator LED 3, a speaker 4, volume adjustment controls 5, an LCD display 6 and a keypad 7. The keypad 7 has a plurality of individual keys, such a YES button 12

and a NO button 13, arrow keys 14, 15, a clear key 16, numeric keys 17 (labeled 0 through 9), a star key 18 and a hash key 19.” Sparre at 8.

1/2

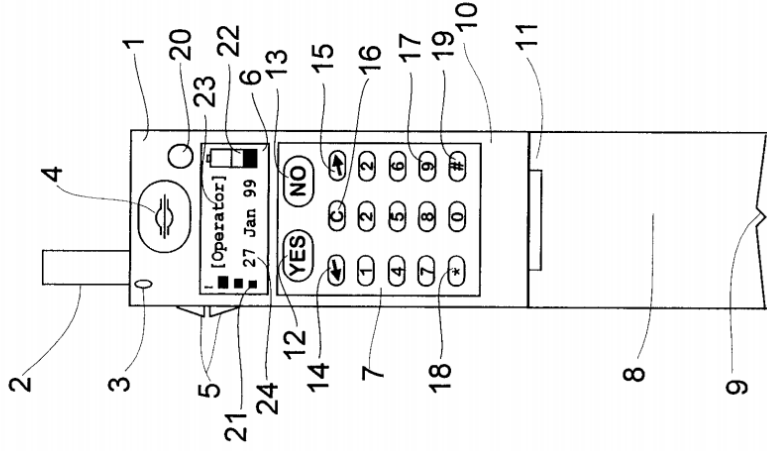

FIG 1

Sparre at Fig. 1.

“Preferably, the endless Proximity Sleep Mode routine 100 may be interrupted by the controller 30 (pre-emptive scheduling), so that other tasks with higher priority may be

executed instead of routine 100. For instance, as soon as the controller 30 has detected that the user has started initiating an outgoing call, the routine 100 is temporarily stopped and the display 6 is activated, thereby avoiding an undesired situation where e.g. the hand or head of the user is accidentally detected by the proximity detector 20, while the telephone number to be called is entered on the keypad 7.

Correspondingly, routine 100 may be temporarily aborted upon detection of an incoming telephone call, text message (SMS; Short Messages Services), etc.” Sparre at 13.

“10. A portable electric apparatus (1) according to any preceding claim, wherein the apparatus is a telecommunication device, preferably a mobile telephone (1).” Sparre at claim 10.

To the extent Sparre is deemed to not expressly disclose that “the telephone call is a wireless telephone call,” Sparre inherently discloses this limitation. In Sparre, the “portable electric apparatus” “is a telecommunication device, preferably a mobile telephone.” Sparre at claim 10. A person of skill in the art would understand that if the portable electric apparatus is a mobile telephone, and the mobile telephone is adapted to determine whether a telephone call is active, the telephone call performed by the portable electronic apparatus is necessarily a wireless telephone call.

To the extent Sparre is deemed to not expressly or inherently disclose that “the telephone call is a wireless telephone call,” Sparre renders this limitation obvious to a person of skill in the art. A person of skill in the art would be motivated to modify the

<p>[1h] the microprocessor reduces power to the display while the signal indicates the proximity of the external object only if the microprocessor determines that the wireless telephone call is active; and</p>	<p>the telephone call described in Sparre such that it is a wireless telephone call because doing so would better utilize the <i>mobile</i> configuration of mobile telephone 1 in Sparre.</p>
<p>Sparre discloses that the microprocessor reduces power to the display while the signal indicates the proximity of the external object only if the microprocessor determines that the wireless telephone call is active.</p> <p>For example: <i>see</i> discussion of claim element [1f], <i>supra</i>, which is incorporated herein by reference.</p> <p>To the extent Sparre is deemed to not expressly disclose that “the microprocessor reduces power to the display while the signal indicates the proximity of the external object only if the microprocessor determines that the wireless telephone call is active,” Sparre inherently discloses this limitation. As explained above for element [1d], and incorporated herein by reference, Sparre explicitly or inherently discloses, or renders obvious a microprocessor adapted to “determine whether a telephone call is active.” Sparre further discloses that instead of constantly monitoring the proximity sensor, the microprocessor of Sparre could be configured to monitor the proximity sensor in other “known power preservation arrangements.” <i>See</i> Sparre at 13 (“As an alternative to the endless loop formed by routine 100 in FIG 3, the Proximity Sleep Mode routine may be executed by the controller 30 according to a predetermined time schedule, for instance once every second, without returning to the beginning of routine 100 upon termination of the last step 140, 155b or 157a, respectively. The invention has been described above with reference to a few embodiments. However, the present invention shall in no way be limited by the description above; the scope of the invention is best defined by the appended independent claims. Other embodiments than the particular ones described above are equally possible within the scope of the invention. The invention may also be combined with known power preservation arrangements, such as automatically turning off the display backlighting after certain time, as described in previous sections.”). A person of ordinary skill in the art at the time of the alleged invention would understand that a known power preservation arrangement that would necessarily be employed to further Sparre’s goal of battery conservation would be to only monitor Sparre’s proximity sensor when Sparre’s</p>	<p>Sparre discloses that the microprocessor reduces power to the display while the signal indicates the proximity of the external object only if the microprocessor determines that the wireless telephone call is active.</p> <p>For example: <i>see</i> discussion of claim element [1f], <i>supra</i>, which is incorporated herein by reference.</p> <p>To the extent Sparre is deemed to not expressly disclose that “the microprocessor reduces power to the display while the signal indicates the proximity of the external object only if the microprocessor determines that the wireless telephone call is active,” Sparre inherently discloses this limitation. As explained above for element [1d], and incorporated herein by reference, Sparre explicitly or inherently discloses, or renders obvious a microprocessor adapted to “determine whether a telephone call is active.” Sparre further discloses that instead of constantly monitoring the proximity sensor, the microprocessor of Sparre could be configured to monitor the proximity sensor in other “known power preservation arrangements.” <i>See</i> Sparre at 13 (“As an alternative to the endless loop formed by routine 100 in FIG 3, the Proximity Sleep Mode routine may be executed by the controller 30 according to a predetermined time schedule, for instance once every second, without returning to the beginning of routine 100 upon termination of the last step 140, 155b or 157a, respectively. The invention has been described above with reference to a few embodiments. However, the present invention shall in no way be limited by the description above; the scope of the invention is best defined by the appended independent claims. Other embodiments than the particular ones described above are equally possible within the scope of the invention. The invention may also be combined with known power preservation arrangements, such as automatically turning off the display backlighting after certain time, as described in previous sections.”). A person of ordinary skill in the art at the time of the alleged invention would understand that a known power preservation arrangement that would necessarily be employed to further Sparre’s goal of battery conservation would be to only monitor Sparre’s proximity sensor when Sparre’s</p>

microprocessor determines that a call is active. This would further preserve battery power that would otherwise be spent needlessly monitoring the proximity sensor. Therefore a person of ordinary skill in the art at the time of the alleged invention would understand that Sparre necessarily discloses that “the microprocessor reduces power to the display while the signal indicates the proximity of the external object only if the microprocessor determines that the wireless telephone call is active.”

To the extent Sparre is deemed to not expressly or inherently disclose that “the microprocessor reduces power to the display while the signal indicates the proximity of the external object only if the microprocessor determines that the wireless telephone call is active,” Sparre renders this limitation obvious to one of skill in the art. For example, as explained above for element [1d], and incorporated herein by reference, Sparre explicitly or inherently discloses, or renders obvious a microprocessor adapted to “determine whether a telephone call is active.” Sparre further discloses that instead of constantly monitoring the proximity sensor, the microprocessor of Sparre could be configured to monitor the proximity sensor in other “known power preservation arrangements.” *See* Sparre at 13 (“As an alternative to the endless loop formed by routine 100 in FIG 3, the Proximity Sleep Mode routine may be executed by the controller 30 according to a predetermined time schedule, for instance once every second, without returning to the beginning of routine 100 upon termination of the last step 140, 155b or 157a, respectively. The invention has been described above with reference to a few embodiments. However, the present invention shall in no way be limited by the description above; the scope of the invention is best defined by the appended independent claims. Other embodiments than the particular ones described above are equally possible within the scope of the invention. The invention may also be combined with known power preservation arrangements, such as automatically turning off the display backlighting after certain time, as described in previous sections.”). A person of ordinary skill in the art at the time of the alleged invention would understand that a known power preservation arrangement that could be employed to further Sparre’s goal of battery conservation would be to only monitor Sparre’s proximity sensor when Sparre’s microprocessor determines that a call is active. This would further preserve battery power that would

otherwise be spent needlessly monitoring the proximity sensor. It would therefore be obvious to one of ordinary skill in the art at the time of the alleged invention that the microprocessor of Sparre be modified such that “the microprocessor reduces power to the display while the signal indicates the proximity of the external object only if the microprocessor determines that the wireless telephone call is active.” Doing so would be within the skill of one of ordinary skill in the art, and would constitute, at least, combining prior art elements according to known methods to yield predictable results, a simple substitution of one known element for another to obtain predictable results, the use of a known technique to improve similar devices in the same way, the application of a known technique to a known device ready for improvement to yield a predictable result, and obvious to try.

To the extent Sparre is deemed to not expressly or inherently disclose that “the microprocessor reduces power to the display while the signal indicates the proximity of the external object only if the microprocessor determines that the wireless telephone call is active,” it would be obvious to combine the disclosure of Sparre with those of Fukiharu 598 as described in the Fukiharu 598 claim chart, which is incorporated herein in its entirety by reference. Sparre and Fukiharu 598 are both directed to conserving battery power in mobile stations generally and more particularly at conserving battery power in mobile stations by using sensors to detect when the user of the mobile station is in a call and unlikely to be looking at the display (as when, for example, the proximity sensor detects the user’s ear by the mobile station) and to power off the display of mobile stations at such times. Sparre at 6 (“The purpose of the present invention is to propose an improved solution to the problem of preserving electric power in a portable electric apparatus having a liquid crystal display. In particular, the invention aims at achieving such power preservation at a lower cost and with improved accuracy, as compared to the prior art solutions. According to the invention, the portable electric apparatus is provided with a proximity detector, which is arranged to detect when an external object is very close to a specific portion of the apparatus (for instance less than 3 cm from the display). The external object may be the user’s ear (when the telephone is held in a normal position for conversation), or the interior walls of a pocket or bag, in which the telephone has been placed by the

<p>user. In all circumstances, the presence of such an external object indicates that the apparatus is not in a position, where it is useful to keep the display turned on, since the user is physically prevented from visual access to the display. Therefore, when the proximity detector has detected the presence of the external object, the display may be powered off or present less visual information.); Fukiharu 598 at ¶ 0018 (“The present invention, through the use of a structure as described above, enables a reduction in the consumption of battery power, through enabling the lighting devices to be turned OFF when the ear is caused to contact the receiver portion in order to hear the receiver sound during voice communications of a mobile telephone when the lighting devices (backlights) for a liquid crystal display device and keypad portion of a mobile telephone are lit, such as that night.”). A person of ordinary skill in the art at the time of the alleged invention would be motivated to modify Sparre such that “the microprocessor reduces power to the display while the signal indicates the proximity of the external object only if the microprocessor determines that the wireless telephone call is active,” as disclosed in Fukiharu 598 for a number of different reasons, including that it would support Sparre’s ability to conserve battery power in mobile stations, and doing so would be within the knowledge and ability of a person of ordinary skill in the art at the time of the alleged invention. Furthermore, as noted above, Sparre invites combinations with “known power preservation arrangements” such as the one in Fukiharu 598. The combination would constitute, at least, combining prior art elements according to known methods to yield predictable results, a simple substitution of one known element for another to obtain predictable results, the use of a known technique to improve similar devices in the same way, the application of a known technique to a known device ready for improvement to yield a predictable result, and obvious to try.</p>	<p>Sparre discloses the proximity sensor beginning to detect whether an external object is proximate substantially concurrently with the mobile station initiating an outgoing wireless telephone call or receiving an incoming wireless telephone call.</p>
	<p>[11] the proximity sensor begins detecting whether an external object is proximate substantially concurrently with the mobile station initiating an outgoing wireless telephone call or receiving an incoming wireless telephone call.</p>

For example: *see* discussion of claim element [1f], *supra*, which is incorporated herein by reference.

To the extent Sparre is deemed to not expressly disclose that “the proximity sensor begins detecting an external object is proximate substantially concurrently with the mobile station initiating an outgoing wireless telephone call or receiving an incoming wireless telephone call,” Sparre inherently discloses this limitation. As explained above for element [1d], and incorporated herein by reference, Sparre explicitly or inherently discloses, or renders obvious a microprocessor adapted to “determine whether a telephone call is active.” Sparre further discloses that instead of constantly monitoring the proximity sensor, the microprocessor of Sparre could be configured to monitor the proximity sensor in other “known power preservation arrangements.” *See* Sparre at 13 (“As an alternative to the endless loop formed by routine 100 in FIG 3, the Proximity Sleep Mode routine may be executed by the controller 30 according to a predetermined time schedule, for instance once every second, without returning to the beginning of routine 100 upon termination of the last step 140, 155b or 157a, respectively. The invention has been described above with reference to a few embodiments. However, the present invention shall in no way be limited by the description above; the scope of the invention is best defined by the appended independent claims. Other embodiments than the particular ones described above are equally possible within the scope of the invention. The invention may also be combined with known power preservation arrangements, such as automatically turning off the display backlighting after certain time, as described in previous sections.”). A person of ordinary skill in the art at the time of the alleged invention would understand that a known power preservation arrangement that would necessarily be employed to further Sparre’s goal of battery conservation would be for Sparre’s proximity sensor to be detecting as soon as Sparre’s mobile station has initiated an outgoing wireless telephone call or received an incoming wireless telephone call. This would further Sparre’s goal of preserving battery power by (1) preserving power that would otherwise be spent needlessly powering the proximity sensor when there is no need to monitor it (e.g. before a mobile station has initiated an outgoing wireless telephone call or received an incoming wireless telephone call),

and (2) preserving power by ensuring that the display is not needlessly kept powered on (by enabling the proximity sensor to detect, as soon as call has started, that the display cannot be seen and should be powered off). Therefore a person of ordinary skill in the art at the time of the alleged invention would understand that Sparre necessarily discloses that “the proximity sensor begins detecting whether an external object is proximate substantially concurrently with the mobile station initiating an outgoing wireless telephone call or receiving an incoming wireless telephone call.”

To the extent Sparre is deemed to not expressly or inherently disclose that “the proximity sensor begins detecting whether an external object is proximate substantially concurrently with the mobile station initiating an outgoing wireless telephone call or receiving an incoming wireless telephone call,” Sparre renders this limitation obvious to one of skill in the art. For example, as explained above for element [1d], and incorporated herein by reference, Sparre explicitly or inherently discloses, or renders obvious a microprocessor adapted to “determine whether a telephone call is active.” Sparre further discloses that instead of constantly monitoring the proximity sensor, the microprocessor of Sparre could be configured to monitor the proximity sensor in other “known power preservation arrangements.” *See* Sparre at 13 (“As an alternative to the endless loop formed by routine 100 in FIG 3, the Proximity Sleep Mode routine may be executed by the controller 30 according to a predetermined time schedule, for instance once every second, without returning to the beginning of routine 100 upon termination of the last step 140, 155b or 157a, respectively. The invention has been described above with reference to a few embodiments. However, the present invention shall in no way be limited by the description above; the scope of the invention is best defined by the appended independent claims. Other embodiments than the particular ones described above are equally possible within the scope of the invention. The invention may also be combined with known power preservation arrangements, such as automatically turning off the display backlighting after certain time, as described in previous sections.”). A person of ordinary skill in the art at the time of the alleged invention would understand that a known power preservation arrangement that could be employed to further Sparre’s goal of battery conservation would be to only monitor Sparre’s proximity sensor to being detecting as soon as

Sparre's mobile station has initiated an outgoing wireless telephone call or received an incoming wireless telephone call. This would further Sparre's goal of preserving battery power by (1) preserving power that would otherwise be spent needlessly powering the proximity sensor when there is no need to monitor it (e.g. before a mobile station has initiated an outgoing wireless telephone call or received an incoming wireless telephone call), and (2) preserving power by ensuring that the display is not needlessly kept powered on (by enabling the proximity sensor to detect, as soon as call has started, that the display cannot be seen and should be powered off). It would therefore be obvious to one of ordinary skill in the art at the time of the alleged invention that the microprocessor of Sparre be modified such that "the proximity sensor begins detecting whether an external object is proximate substantially concurrently with the mobile station initiating an outgoing wireless telephone call or receiving an incoming wireless telephone call." Doing so would be within the skill of one of ordinary skill in the art, and would constitute, at least, combining prior art elements according to known methods to yield predictable results, a simple substitution of one known element for another to obtain predictable results, the use of a known technique to improve similar devices in the same way, the application of a known technique to a known device ready for improvement to yield a predictable result, and obvious to try.

To the extent Sparre is deemed to not expressly or inherently disclose that "the proximity sensor begins detecting whether an external object is proximate substantially concurrently with the mobile station initiating an outgoing wireless telephone call or receiving an incoming wireless telephone call," it would be obvious to combine the disclosure of Sparre with those of Fukiharu 598 as described in the Fukiharu 598 claim chart, which is incorporated herein in its entirety by reference. Sparre and Fukiharu 598 are both directed to conserving battery power in mobile stations generally and more particularly at conserving battery power in mobile stations by using sensors to detect when the user of the mobile station is in a call and unlikely to be looking at the display (as when, for example, the proximity sensor detects the user's ear by the mobile station) and to power off the display of mobile stations at such times. Sparre at 6 ("The purpose of the present invention is to propose an improved solution to the

problem of preserving electric power in a portable electric apparatus having a liquid crystal display. In particular, the invention aims at achieving such power preservation at a lower cost and with improved accuracy, as compared to the prior art solutions. According to the invention, the portable electric apparatus is provided with a proximity detector, which is arranged to detect when an external object is very close to a specific portion of the apparatus (for instance less than 3 cm from the display). The external object may be the user's ear (when the telephone is held in a normal position for conversation), or the interior walls of a pocket or bag, in which the telephone has been placed by the user. In all circumstances, the presence of such an external object indicates that the apparatus is not in a position, where it is useful to keep the display turned on, since the user is physically prevented from visual access to the display. Therefore, when the proximity detector has detected the presence of the external object, the display may be powered off or present less visual information.); Fukiharu 598 at ¶ 0018 (“The present invention, through the use of a structure as described above, enables a reduction in the consumption of battery power, through enabling the lighting devices to be turned OFF when the ear is caused to contact the receiver portion in order to hear the receiver sound during voice communications of a mobile telephone when the lighting devices (backlights) for a liquid crystal display device and keypad portion of a mobile telephone are lit, such as that night?”). A person of ordinary skill in the art at the time of the alleged invention would be motivated to modify Sparre such that “the proximity sensor begins detecting whether an external object is proximate substantially concurrently with the mobile station initiating an outgoing wireless telephone call or receiving an incoming wireless telephone call,” as disclosed in Fukihara 598 for a number of different reasons, including that it would support Sparre’s ability to conserve battery power in mobile stations, and doing so would be within the knowledge and ability of a person of ordinary skill in the art at the time of the alleged invention. Furthermore, as noted above, Sparre invites combinations with “known power preservation arrangements” such as the one in Fukihara 598. The combination would constitute, at least, combining prior art elements according to known methods to yield predictable results, a simple substitution of one known element for another to obtain predictable results, the use of a known technique to improve similar devices in the same way, the application of a

	<p>known technique to a known device ready for improvement to yield a predictable result, and obvious to try.</p>
<p>[Claim 2] The mobile station of claim 1, wherein the microprocessor reduces power to the display only if (i) the microprocessor determines that a telephone call is active and (ii) the signal indicates the proximity of the external object.</p>	<p>Sparre discloses the microprocessor reducing power to the display only if (i) the microprocessor determines that a telephone call is active and (ii) the signal indicates the proximity of the external object.</p> <p>For example: <i>see</i> discussion of claim element [1f], <i>supra</i>, which is incorporated herein by reference.</p> <p>To the extent Sparre is deemed to not disclose that “the microprocessor reducing power to the display only if (i) the microprocessor determines that a telephone call is active and (ii) the signal indicates the proximity of the external object,” Sparre renders this limitation obvious to one of skill in the art. Sparre “is directed at a new and inventive way of preserving electric power in such a portable electric apparatus by bringing the display to its inactive state whenever appropriate. Sparre at 1. Sparre discloses that “apparatus (1) also has a proximity detector (20) for detecting the presence of an object in proximity with the apparatus and in response causing the display (6) to enter its inactive state.” Sparre at Abstract. Also, as set forth in the discussion of claim element [1d], <i>supra</i>, Sparre discloses determining whether a telephone call is active. In order to further Sparre’s stated goal of conserving battery power in a mobile telephone, it would be obvious to a person of skill in the art to modify Sparre’s microprocessor reduce power to the display only if (i) the microprocessor determines that a telephone call is active and (ii) the signal indicates the proximity of the external object.</p> <p>To the extent Sparre is deemed to not expressly or inherently disclose that “the microprocessor reduces power to the display only if (i) the microprocessor determines that a telephone call is active and (ii) the signal indicates the proximity of the external object,” it would be obvious to combine the disclosure of Sparre with those of Seo as described in the Seo claim chart, which is incorporated herein in its entirety by</p>

	<p>reference, to disclose this claim element. <i>See</i> discussion of claim element [1f], <i>supra</i>, which is incorporated herein by reference.</p>
<p>[Claim 4] The mobile station as recited in claim 1, wherein the microprocessor reduces power to the display by turning off the display.</p>	<p>Sparre discloses the microprocessor reducing power to the display by turning off the display.</p> <p>For example: “By supplying electric energy from the display driver through the control lines to the liquid crystal layer, individual elements (crystals or molecules) of the liquid crystal layer may be set to either an on-state, representing an active (e.g. black) pixel in the image presented by the liquid crystal display, or an off-state, representing a blank (e.g. transparent) pixel.</p> <p>In more detail, for a passive-type liquid crystal display, the crystals or molecules of the liquid crystal layer are oriented in parallel with the glass plates in their off-state. Due to the provision of the polarizers, such off-state crystals or molecules will not be visible to a viewer. To make specific crystals or molecules visible (i.e., force them to their on-state), the display driver scans (addresses) the control line matrix and supplies electric energy in the form of a voltage pulse on one specific horizontal control line and one specific vertical control line for each pixel to be set on. At the position where these two specific control lines cross each other, an electric field will be generated and change the orientation of the corresponding crystal or molecule from parallel to orthogonal with respect to the glass plates.” Sparre at 2-3.</p> <p>“The document RD-A-332 083, which is available from Derwent Info Ltd under access number 92-022097/199203 in the database commonly known as WPI (World Patent Index) , relates to a portable electric apparatus in the form of a remote control unit. This document observes that the functionality of the remote control unit is only required, when the user focuses attention on it . The remote control unit is provided with a motion or acceleration sensor to detect when the remote control unit is carried in the hand of a user. In the absence of such detection, the remote control unit may determine that the unit is placed on a stable surface and is no longer held by the user,</p>

wherein the power-consuming components of the remote control unit may be switched off in order to preserve electric power of the battery. For instance, the display of the remote control unit consumes a substantial amount of electric power from the battery, and by switching off the display in situations other than when the unit is carried by the user, considerable power may be preserved.” Sparre at 4.

“US-A-5 881 377 discloses a radio telephone with a power-saving arrangement, which is adapted to detect the presence of the radio telephone in proximity with an ear of a user and which also is adapted to turn off a display of the radio telephone. Aforesaid arrangement may be of a type capable of detecting heat, or comprise an opto-electric switch. The display of the radio telephone is of a type comprising light emitting diodes (LED). According to an alternative embodiment of US-A-5 881 377, the display is a liquid crystal display, and a light emitting diode is provided for backlighting the LCD-display. In this embodiment, the backlighting LED, but not the actual liquid crystal display, is switched on and off for saving electric power in response to whether or not the radio telephone is kept near the user's head.

US-A-5 729 604 discloses a wireless telephone handset with an arrangement for detecting that the telephone handset is kept in proximity with an ear of a user. This arrangement may for instance operate by detecting infrared radiation and in response turning off a backlighting of a liquid crystal display.

Consequently, from the two US publications referred to above it is known to provide a radio telephone or a wireless telephone handset with a proximity detector, the purpose of which is to detect when the telephone is kept in proximity with the user. The main embodiment of US-A-5 881 377 teaches that the output from the proximity detector may be used for turning off an LED display. The alternative embodiment of this US-publication, as well as the disclosure in US-A-5 729 604, teaches that the backlighting of a liquid crystal display (LCD) can be switched on and off depending on the output from the proximity detector. The purpose of these inventions is to save electric power when the telephone is kept close to the user (i.e. in proximity with the user's ear in talking position). The liquid crystal display is by far the most commonly used type of display in mobile telephones and other types of portable electric apparatus. Both US publications mention liquid crystal displays, but neither of them

teaches or even suggests to use the output from the proximity detector to turn off the actual LCD display. Thus, the US publications only teach to turn off the backlighting of the display.” Sparre at 5-6.

“According to the invention, the portable electric apparatus is provided with a proximity detector, which is arranged to detect when an external object is very close to a specific portion of the apparatus (for instance less than 3 cm from the display) . The external object may be the user's ear (when the telephone is held in a normal position for conversation) , or the interior walls of a pocket or bag, in which the telephone has been placed by the user. In all circumstances, the presence of such an external object indicates that the apparatus is not in a position, where it is useful to keep the display turned on, since the user is physically prevented from visual access to the display. Therefore, when the proximity detector has detected the presence of the external object, the display may be powered off or present less visual information. More specifically, the purpose above has been achieved for a portable electric apparatus having a display of the type comprising a liquid crystal layer, wherein the display has an active state for presenting visual information in response to a supply of electric energy to the liquid crystal layer, and wherein the display also has an inactive state, in which less electric energy is supplied to the liquid crystal layer and less visual information consequently is presented, by the provision of a proximity detector for detecting the presence of an object in proximity with the apparatus and in response causing the display to enter its inactive state.” Sparre at 6-7.

“The liquid crystal display 6 also has an inactive state, where less or even no electric energy is supplied to the liquid crystal layer and, thus, less visual information is presented on the display. In contrast to the active state, during which all graphical information (e.g. the icons 21-24) is presented on the display, only parts of this graphical information is shown on the display during its inactive state. For instance, with reference to FIG 1, only the remaining battery charge indicator 22 (but not the icons 21, 22 or 24) is presented on the display 6 during its inactive state. Such an inactive state essentially corresponds to the "limited icon mode", which was described in the Prior Art section of this document. Alternatively, the liquid crystal display 6 may be completely turned off in its inactive state (i.e., no electric energy is supplied to the

	<p>liquid crystal layer, wherein the power consumption of the display is essentially zero).” Sparre at 9.</p> <p>“If the answer of step 130 is in the affirmative, the controller 30 forces the liquid crystal display 6 to enter its inactive state in a subsequent step 150. As previously mentioned, the inactive state may either involve displaying only a limited set of icons (such as the remaining battery charge indicator 22), or completely turning off the liquid crystal display 6 by stop supplying electric energy to the liquid crystal layer. The first case is represented by a step 155b in FIG 3, whereas the second case is represented by steps 155a and 157a.” Sparre at 12.</p> <p>“The invention may also be combined with known power preservation arrangements, such as automatically turning off the display backlighting after certain time, as described in previous sections.” Sparre at 13.</p> <p>“9. A portable electric apparatus (1) according to any of claims 1-7, wherein the inactive state of the display</p> <p>(6) is a state, where the display is electrically turned off.” Sparre at Claim 9.</p> <p>See discussion of claim element [1f], <i>supra</i>, which is incorporated herein by reference.</p>
<p>[Claim 5] The mobile station as recited in claim 1, wherein the proximity sensor is a mechanical proximity sensor, an optical sensor, or a range-detecting sensor.</p>	<p>Sparre discloses that the proximity sensor is a mechanical proximity sensor, an optical sensor, or a range-detecting sensor.</p> <p>For example: <i>see</i> discussion of claim element [1b], <i>supra</i>, which is incorporated herein by reference.</p> <p>“The document RD-A-332 083, which is available from Derwent Info Ltd under access number 92-022097/199203 in the database commonly known as WPI (World Patent Index) , relates to a portable electric apparatus in the form of a remote control unit. This document observes that the functionality of the remote control unit is only required, when the user focuses attention on it . The remote control unit is provided</p>

with a motion or acceleration sensor to detect when the remote control unit is carried in the hand of a user. In the absence of such detection, the remote control unit may determine that the unit is placed on a stable surface and is no longer held by the user, wherein the power-consuming components of the remote control unit may be switched off in order to preserve electric power of the battery. For instance, the display of the remote control unit consumes a substantial amount of electric power from the battery, and by switching off the display in situations other than when the unit is carried by the user, considerable power may be preserved.” Sparre at 4.

“US-A-5 881 377 discloses a radio telephone with a power-saving arrangement, which is adapted to detect the presence of the radio telephone in proximity with an ear of a user and which also is adapted to turn off a display of the radio telephone. Aforesaid arrangement may be of a type capable of detecting heat, or comprise an opto-electric switch. The display of the radio telephone is of a type comprising light emitting diodes (LED) . According to an alternative embodiment of US-A-5 881 377, the display is a liquid crystal display, and a light emitting diode is provided for backlighting the LCD-display. In this embodiment, the backlighting LED, but not the actual liquid crystal display, is switched on and off for saving electric power in response to whether or not the radio telephone is kept near the user’s head.” Sparre at 5.

“US-A-5 729 604 discloses a wireless telephone handset with an arrangement for detecting that the telephone handset is kept in proximity with an ear of a user. This arrangement may for instance operate by detecting infrared radiation and in response turning off a backlighting of a liquid crystal display” Sparre at 5.

“Consequently, from the two US publications referred to above it is known to provide a radio telephone or a wireless telephone handset with a proximity detector, the purpose of which is to detect when the telephone is kept in proximity with the user. The main embodiment of US-A-5 881 377 teaches that the output from the proximity detector may be used for turning off an LED display. The alternative embodiment of this US-publication, as well as the disclosure in US-A-5 729 604, teaches that the backlighting of a liquid crystal display (LCD) can be switched on and off depending on the output from the proximity detector. The purpose of these inventions is to save electric power when the telephone is kept close to the user (i.e. in proximity with the

user's ear in talking position). The liquid crystal display is by far the most commonly used type of display in mobile telephones and other types of portable electric apparatus. Both US publications mention liquid crystal displays, but neither of them teaches or even suggests to use the output from the proximity detector to turn off the actual LCD display. Thus, the US publications only teach to turn off the backlighting of the display." Sparre at 5-6.

"According to the invention, the portable electric apparatus is provided with a proximity detector, which is arranged to detect when an external object is very close to a specific portion of the apparatus (for instance less than 3 cm from the display) . The external object may be the user's ear (when the telephone is held in a normal position for conversation) , or the interior walls of a pocket or bag, in which the telephone has been placed by the user. In all circumstances, the presence of such an external object indicates that the apparatus is not in a position, where it is useful to keep the display turned on, since the user is physically prevented from visual access to the display. Therefore, when the proximity detector has detected the presence of the external object, the display may be powered off or present less visual information. More specifically, the purpose above has been achieved for a portable electric apparatus having a display of the type comprising a liquid crystal layer, wherein the display has an active state for presenting visual information in response to a supply of electric energy to the liquid crystal layer, and wherein the display also has an inactive state, in which less electric energy is supplied to the liquid crystal layer and less visual information consequently is presented, by the provision of a proximity detector for detecting the presence of an object in proximity with the apparatus and in response causing the display to enter its inactive state." Sparre at 6-7.

"The liquid crystal display 6 also has an inactive state, where less or even no electric energy is supplied to the liquid crystal layer and, thus, less visual information is presented on the display. In contrast to the active state, during which all graphical information (e.g. the icons 21-24) is presented on the display, only parts of this graphical information is shown on the display during its inactive state. For instance, with reference to FIG 1, only the remaining battery charge indicator 22 (but not the icons 21, 22 or 24) is presented on the display 6 during its inactive state. Such an inactive state essentially corresponds to the "limited icon mode", which was described

in the Prior Art section of this document. Alternatively, the liquid crystal display 6 may be completely turned off in its inactive state (i.e., no electric energy is supplied to the liquid crystal layer, wherein the power consumption of the display is essentially zero).” Sparre at 9.

“In one embodiment, the proximity detector 20 is an IR (infrared) detector, which is arranged to emit infrared light from the front surface of the telephone 1 and is arranged to detect infrared light, that has been reflected from an external object located close to the upper portion of front surface of the telephone 1. Hence, as is generally known per se, the proximity detector 20 may measure the intensity of the reflected infrared light and in response determine whether any external object is present in proximity with the detector 20. By establishing a predetermined threshold for the fraction of infrared light reflected back to the proximity detector 20, it is possible to define a predetermined range, within which any external object will be detected by the proximity detector 20. Obviously, such a threshold will depend on i.a. the surface structure and material of the external object in question. However, such an issue is regarded nothing more than a practical parameter, which in an actual application will have to be tested, evaluated and determined by a skilled person. Proximity detectors as such are generally known and are commercially available on the market in large numbers .

According to an alternative embodiment, if the mobile telephone is equipped with an IR interface for wireless data communication with external devices (such as a handheld computer) , the IR transmitter thereof may be used also for the purpose of transmitting IR light to be detected by the proximity detector 20.

Alternatively, the proximity detector 20 may operate by emitting and detecting visible light, by detecting thermal energy generated by the external object, or by detecting the external object by capacitive means.” Sparre at 9-10.

“If the answer of step 130 is in the affirmative, the controller 30 forces the liquid crystal display 6 to enter its inactive state in a subsequent step 150. As previously mentioned, the inactive state may either involve displaying only a limited set of icons (such as the remaining battery charge indicator 22), or completely turning off the liquid crystal display 6 by stop supplying electric energy to the liquid crystal layer. The

first case is represented by a step 155b in FIG 3, whereas the second case is represented by steps 155a and 157a. Following the last step (i.e., either step 155b or step 157a) the control is transferred back to the beginning of routine 100. If, on the other hand, no external object has been detected in step 130, the controller 30 causes the liquid crystal display 6 to enter its active state, provided that the display 6 is not already active, in a step 140. When step 140 has been completed, the control is transferred back to the beginning of routine 100. In this way, an endless loop is formed by steps 100, 110, 120, 130, 140, 150 and 155b and 155a, 157a, respectively. Consequently, the presence of an external object in proximity with the proximity detector 20 will be continuously monitored, and in response to detecting such an external object, the display 6 will be set to its active state, thereby saving electric power. Furthermore, if the external object disappears from the proximity detector 20, the display 6 is again set to its active state in step 140.” Sparre at 12-13.

“The invention may also be combined with known power preservation arrangements, such as automatically turning off the display backlighting after certain time, as described in previous sections.” Sparre at 13.

“1. A portable electric apparatus (1) having a display (6) of the type comprising a liquid crystal, the display having an active state for presenting visual information in response to a supply of electric energy to the liquid crystal layer, the display also having an inactive state, in which less electric energy is supplied to the liquid crystal layer and less visual information consequently is presented, characterized by a proximity detector (20) for detecting the presence of an object in proximity with the apparatus (1) and in response causing the display (6) to enter its inactive state.

2. A portable electric apparatus (1) according to claim 1, wherein the proximity detector (20) operates by detecting infrared (IR) light.

3. A portable electric apparatus (1) according to claim 1, wherein the proximity detector (20) operates by detecting visible light.

4. A portable electric apparatus (1) according to claim 1, wherein the proximity detector (20) operates by detecting thermal energy generated by said object.

<p>5. A portable electric apparatus (1) according to claim 1, wherein the proximity detector (20) operates by detecting said object by capacitive means.” Sparre at claims 1-5.</p> <p>“9. A portable electric apparatus (1) according to any of claims 1-7, wherein the inactive state of the display (6) is a state, where the display is electrically turned off.” Sparre at claim 9.</p>	
<p>Sparre discloses that the proximity sensor is located proximate to the display.</p> <p>For example: “A portable electric apparatus (1) has a display (6) of the type comprising a liquid crystal layer. The display has an active state for presenting visual information in response to a supply of electric energy to the liquid crystal layer. The display also has an inactive state, in which less electric energy is supplied to the liquid crystal layer and less visual information consequently is presented. The apparatus (1) also has a proximity detector (20) for detecting the presence of an object in proximity with the apparatus and in response causing the display (6) to enter its inactive state.” Sparre at Abstract.</p> <p>“A proximity detector is provided at the uppermost portion of the front surface of the telephone 1. In the embodiment shown in FIG 1, the proximity detector 20 is located immediately above the display 6 next to the speaker 4. However, the exact location of the proximity detector 20 is not critical but may be varied between many different positions, as long as the functional requirements specified below are satisfied.</p> <p>In one embodiment, the proximity detector 20 is an IR (infrared) detector, which is arranged to emit infrared light from the front surface of the telephone 1 and is arranged to detect infrared light, that has been reflected from an external object located close to the upper portion of front surface of the telephone 1. Hence, as is generally known per se, the proximity detector 20 may measure the intensity of the reflected infrared light and in response determine whether any external object is present in proximity with the detector 20. By establishing a predetermined threshold for the fraction of infrared light reflected back to the proximity detector 20, it is possible to</p>	<p>[Claim 6] The mobile station as recited in claim 1, wherein the proximity sensor is located proximate to the display.</p>

<p>define a predetermined range, within which any external object will be detected by the proximity detector 20. Obviously, such a threshold will depend on i.a. the surface structure and material of the external object in question. However, such an issue is regarded nothing more than a practical parameter, which in an actual application will have to be tested, evaluated and determined by a skilled person. Proximity detectors as such are generally known and are commercially available on the market in large numbers .</p> <p>According to an alternative embodiment, if the mobile telephone is equipped with an IR interface for wireless data communication with external devices (such as a handheld computer) , the IR transmitter thereof may be used also for the purpose of transmitting IR light to be detected by the proximity detector 20.</p> <p>Alternatively, the proximity detector 20 may operate by emitting and detecting visible light, by detecting thermal energy generated by the external object, or by detecting the external object by capacitive means.” Sparre at 9-10.</p>	
---	--

1/2

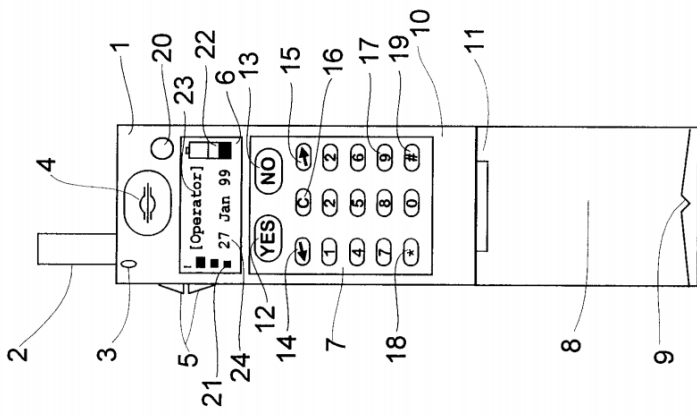
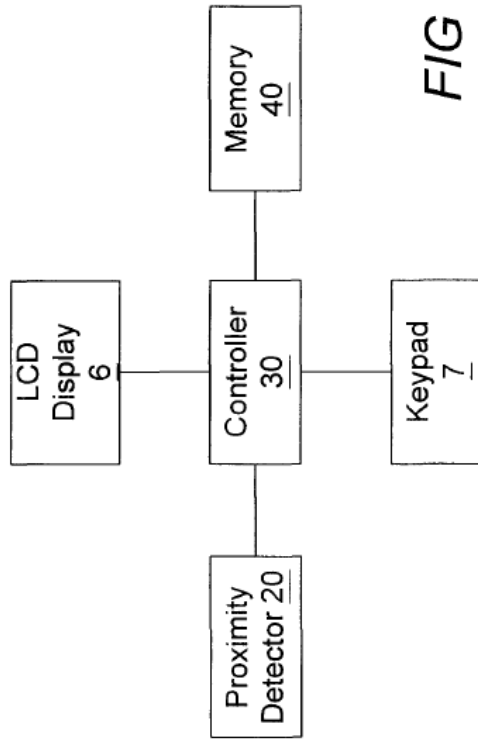

FIG 1

Sparre at Fig. 1.

“The main components of the mobile telephone 1 are shown in FIG 2. A controller 30 is operatively connected to the display 6, the keypad 7, the proximity detector 20 and a memory 40.” Sparre at 10.



Sparre at Fig. 2.

“1. A portable electric apparatus (1) having a display (6) of the type comprising a liquid crystal, the display having an active state for presenting visual information in response to a supply of electric energy to the liquid crystal layer, the display also having an inactive state, in which less electric energy is supplied to the liquid crystal layer and less visual information consequently is presented, characterized by a proximity detector (20) for detecting the presence of an object in proximity with the apparatus (1) and in response causing the display (6) to enter its inactive state.” Sparre at claim 1.

“6. A portable electric apparatus (1) according to any preceding claim, the apparatus having a front surface (10) at which the display (6) is located, wherein the proximity detector (20) is located at said front surface.” Sparre at claim 6.

[Claim 8 – Preamble] 8. A method of conserving battery power in a mobile station, comprising:

Sparre discloses a method of conserving battery power in a mobile station.

For example: *see* discussion of claim 1, *supra*, which is incorporated herein by reference.

“A PORTABLE ELECTRIC APPARATUS HAVING A LIQUID CRYSTAL DISPLAY, AND A POWER PRESERVATION METHOD FOR SUCH AN APPARATUS.” Sparre at Title.

“11. A method of preserving power for a portable electric apparatus (1) having a display (6) of the type comprising a liquid crystal layer, the display having an active state for presenting visual information in response to a supply of electric energy to the liquid crystal layer, the display also having an inactive state, in which less electric energy is supplied to the liquid crystal layer and less visual information consequently is presented, characterized by the steps of determining whether an object is present in proximity with the apparatus (1) , and, if so, causing the display (6) to enter its inactive state.” Sparre at claim 11.

“The present invention relates to a portable electric apparatus having a display of the type comprising a liquid crystal layer, the display having an active state for presenting visual information in response to a supply of electric energy to the liquid crystal layer, the display also having an inactive state, in which less electric energy is supplied to the liquid crystal layer and less visual information consequently is presented. More specifically, the invention is directed at a new and inventive way of preserving electric power in such a portable electric apparatus by bringing the display to its inactive state whenever appropriate. The invention also relates to a method of preserving power for such an apparatus.” Sparre at 1.

“Examples of portable electric apparatuses as set out above are for instance mobile or cellular telephones, wireless telephone handsets, personal communicators, portable digital assistants, palmtop computers, etc. The users thereof are dependent of a fully functional apparatus. More specifically, one of the most common problems in this respect is the limited operational duration between subsequent chargings of a battery used for supplying power to the apparatus. While it has been possible to reach reduced power consumption through the development of low-voltage, high-density integrated

circuits, battery capacity is still a major obstacle against full user freedom in terms of virtually unlimited operational duration. Consequently, preservation of electric power is still a very important issue within the field of portable electric apparatuses. For the rest of this document, reference is made to a mobile telephone, which is chosen to represent a portable electric apparatus according to the invention. However, the invention shall in no way be limited to merely a mobile telephone. In a mobile telephone, the liquid crystal display (LCD) is responsible for a significant part of the total power consumption thereof.” Sparre at 1-2.

“The highest power consumption for a liquid crystal display occurs when an event takes place in the telephone, for instance when a telephone call is generated or ended. In those situations, the visibility of the LCD display is amplified by turning on a back-light illumination of the display. Such back-light illumination consumes too much power than what is acceptable in a long-term perspective. Therefore, back-light illumination is normally restricted to a short time period of a few seconds around the respective event, such as the entering of a telephone number on the keypad, the reception of an incoming call or the termination of an ongoing call (on-hook).

Even if back-light illumination is avoided to a large extent, the display nevertheless consumes electric power also in stand-by mode. The reason for this is that status information has to be presented to the user. Examples of such status information are: current network operator, received signal strength indicator (RSSI), remaining battery capacity, time of day, etc.

Some prior art mobile telephones offer "limited icon mode" during stand-by mode, wherein the display is partially powered off, so that only critical information is displayed. While this approach provides a certain reduction in power consumption, a significant amount of electric power will still be unnecessarily consumed by the display, if the telephone is left in stand-by mode for a long period of time in a bag, a pocket, etc.” Sparre at 3-4.

“The purpose of the present invention is to propose an improved solution to the problem of preserving electric power in a portable electric apparatus having a liquid crystal display. In particular, the invention aims at achieving such power preservation

	<p>at a lower cost and with improved accuracy, as compared to the prior art solutions.” Sparre at 6.</p> <p>“The purpose has also been achieved through a method of preserving power for a portable electric apparatus having a display of the type comprising a liquid crystal layer, the display having an active state for presenting visual information in response to a supply of electric energy to the liquid crystal layer, the display also having an inactive state, in which less electric energy is supplied to the liquid crystal layer and less visual information consequently is presented, by the steps of determining whether an object is present in proximity with the apparatus, and, if so, causing the display to enter its inactive state.” Sparre at 7.</p> <p>“The liquid crystal display 6 also has an inactive state, where less or even no electric energy is supplied to the liquid crystal layer and, thus, less visual information is presented on the display. In contrast to the active state, during which all graphical information (e.g. the icons 21-24) is presented on the display, only parts of this graphical information is shown on the display during its inactive state. For instance, with reference to FIG 1, only the remaining battery charge indicator 22 (but not the icons 21, 22 or 24) is presented on the display 6 during its inactive state. Such an inactive state essentially corresponds to the "limited icon mode", which was described in the Prior Art section of this document. Alternatively, the liquid crystal display 6 may be completely turned off in its inactive state (i.e., no electric energy is supplied to the liquid crystal layer, wherein the power consumption of the display is essentially zero).” Sparre at 9.</p> <p>“The invention may also be combined with known power preservation arrangements, such as automatically turning off the display backlighting after certain time, as described in previous sections.” Sparre at 13.</p>
<p>[8a] detecting whether an external object is proximate;</p>	<p>Sparre discloses detecting whether an external object is proximate.</p>

	<p>For example: <i>see</i> discussion of claim element [1b], <i>supra</i>, which is incorporated herein by reference.</p>
<p>[8b] determining whether a telephone call is active; and</p>	<p>Sparre discloses determining whether a telephone call is active.</p> <p>For example: <i>see</i> discussion of claim element [1d], <i>supra</i>, which is incorporated herein by reference.</p> <p>To the extent Sparre is deemed to not expressly disclose this claim element, Sparre inherently discloses this claim element. <i>See</i> discussion of claim element [1d], <i>supra</i>, which is incorporated herein by reference.</p> <p>To the extent Sparre is deemed to not expressly or inherently disclose this claim element, Sparre renders this claim element obvious to a person of skill in the art at the time of the alleged invention. <i>See</i> discussion of claim element [1d], <i>supra</i>, which is incorporated herein by reference.</p> <p>To the extent Sparre is deemed to not expressly or inherently disclose this claim element, it would be obvious to combine the disclosure of Sparre with those of Fukihar 598 as described in the Fukihar 598 claim chart, which is incorporated herein in its entirety by reference, to disclose this claim element. <i>See</i> discussion of claim element [1d], <i>supra</i>, which is incorporated herein by reference.</p>
<p>[8c] reducing power consumption of a display of the mobile station if (i) a telephone call is determined to be active and (ii) the proximity of the external object is detected; wherein:</p>	<p>Sparre discloses reducing power consumption of a display of the mobile station if (i) a telephone call is determined to be active and (ii) the proximity of the external object is detected.</p> <p>For example: <i>see</i> discussion of claim element [1f], <i>supra</i>, which is incorporated herein by reference.</p>

	<p>To the extent Sparre is deemed to not expressly disclose this claim element, Sparre inherently discloses this claim element. <i>See</i> discussion of claim element [1f] and [1h], <i>supra</i>, which are incorporated herein by reference.</p> <p>To the extent Sparre is deemed to not expressly or inherently disclose this claim element, Sparre renders this claim element obvious to a person of skill in the art at the time of the alleged invention. <i>See</i> discussion of claim elements [1f] and [1h], <i>supra</i>, which are incorporated herein by reference.</p> <p>To the extent Sparre is deemed to not expressly or inherently disclose this claim element, it would be obvious to combine the disclosure of Sparre with those of Fukihar 598 as described in the Fukihar 598 claim chart, which is incorporated herein in its entirety by reference, to disclose this claim element. <i>See</i> discussion of claim elements [1f] and [1h], <i>supra</i>, which are incorporated herein by reference.</p>
<p>[8d] the telephone call is a wireless telephone call;</p>	<p>Sparre discloses that the telephone call is a wireless telephone call.</p> <p>For example: <i>see</i> discussion of claim element [1g], <i>supra</i>, which is incorporated herein by reference.</p>
<p>[8e] the power consumption of the display is reduced while the proximity of the external object is detected only if the wireless telephone call is determined to be active; and</p>	<p>Sparre discloses that the power consumption of the display is reduced while the proximity of the external object is detected only if the wireless telephone call is determined to be active.</p> <p>For example: <i>see</i> discussion of claim element [1f], <i>supra</i>, which is incorporated herein by reference.</p> <p>To the extent Sparre is deemed to not expressly disclose this claim element, Sparre inherently discloses this claim element. <i>See</i> discussion of claim element [1f] and [1h], <i>supra</i>, which are incorporated herein by reference.</p>

	<p>To the extent Sparre is deemed to not expressly or inherently disclose this claim element, Sparre renders this claim element obvious to a person of skill in the art at the time of the alleged invention. <i>See</i> discussion of claim elements [1f] and [1h], <i>supra</i>, which are incorporated herein by reference.</p> <p>To the extent Sparre is deemed to not expressly or inherently disclose this claim element, it would be obvious to combine the disclosure of Sparre with those of Fukihar 598 as described in the Fukihar 598 claim chart, which is incorporated herein in its entirety by reference, to disclose this claim element. <i>See</i> discussion of claim elements [1f] and [1h], <i>supra</i>, which are incorporated herein by reference.</p>
<p>[8f] detecting whether an external object is proximate begins substantially concurrently with the mobile station initiating an outgoing wireless telephone call or receiving an incoming wireless telephone call.</p>	<p>Sparre discloses that detecting whether an external object is proximate begins substantially concurrently with the mobile station initiating an outgoing wireless telephone call or receiving an incoming wireless telephone call.</p> <p>For example: <i>see</i> discussion of claim element [1i], <i>supra</i>, which is incorporated herein by reference.</p> <p>To the extent Sparre is deemed to not expressly disclose this claim element, Sparre inherently discloses this claim element. <i>See</i> discussion of claim element [1i], <i>supra</i>, which is incorporated herein by reference.</p> <p>To the extent Sparre is deemed to not expressly or inherently disclose this claim element, Sparre renders this claim element obvious to a person of skill in the art at the time of the alleged invention. <i>See</i> discussion of claim element [1i], <i>supra</i>, which is incorporated herein by reference.</p> <p>To the extent Sparre is deemed to not expressly or inherently disclose this claim element, it would be obvious to combine the disclosure of Sparre with those of Fukihar 598 as described in the Fukihar 598 claim chart, which is incorporated herein in its entirety by reference, to disclose this claim element. <i>See</i> discussion of claim element [1i], <i>supra</i>, which is incorporated herein by reference.</p>

<p>[Claim 12] The method as recited in claim 8, wherein the detecting of the proximity of the external object is performed by a mechanical proximity sensor, an optical sensor, or a range-detecting sensor.</p>	<p>Sparre discloses that the detecting of the proximity of the external object is performed by a mechanical proximity sensor, an optical sensor, or a range-detecting sensor.</p> <p>For example: <i>see</i> discussion of claim 5, <i>supra</i>, which is incorporated herein by reference.</p>
--	---