



US007000063B2

(12) **United States Patent**
Friedman et al.

(10) **Patent No.:** **US 7,000,063 B2**
(45) **Date of Patent:** **Feb. 14, 2006**

(54) **WRITE-MANY MEMORY DEVICE AND METHOD FOR LIMITING A NUMBER OF WRITES TO THE WRITE-MANY MEMORY DEVICE**

6,222,762 B1 4/2001 Guterman et al.
6,236,587 B1 5/2001 Gudesen et al.
6,278,633 B1 8/2001 Wong et al.
6,363,008 B1 3/2002 Wong
6,376,282 B1 4/2002 Corisis
6,376,284 B1 4/2002 Gonzalez et al.

(75) Inventors: **David R. Friedman**, Menlo Park, CA (US); **J. James Tringali**, Los Altos, CA (US)

OTHER PUBLICATIONS

“64Mx8 Bit NAND Flash Memory,” Samsung Electronics (Oct. 27, 2000).

(73) Assignee: **Matrix Semiconductor, Inc.**, Santa Clara, CA (US)

“How Flash Memory Works,” wysiwyg://8/http://www.howstuffworks.com/flash-memory.htm?printable=1, 5 pages (1998).

(*) Notice: Subject to any disclaimer, the term of this patent is extended or adjusted under 35 U.S.C. 154(b) by 342 days.

“Datalight FlashFX™ 4.06 User’s Guide,” p. 11 (Aug. 2000).

(Continued)

(21) Appl. No.: **09/972,787**

Primary Examiner—Kevin L. Ellis

(22) Filed: **Oct. 5, 2001**

(74) *Attorney, Agent, or Firm*—Brinks Hofer Gilson & Lione

(65) **Prior Publication Data**

US 2003/0070034 A1 Apr. 10, 2003

(57) **ABSTRACT**

(51) **Int. Cl.**
G06F 12/14 (2006.01)

The preferred embodiments described herein provide a write-many memory device and method for limiting a number of writes to the write-many memory device. In one preferred embodiment, a write-many memory device is provided comprising a plurality of blocks of memory, each block being limited to N number of writes. Data can be stored in a block of memory only if there has been fewer than N number of writes to the block. In another preferred embodiment, a write-many memory device is provided comprising a plurality of blocks of memory, wherein each block comprises a first sideband field storing data indicating whether the block is free and a second sideband field storing data indicating how many times the block has been written into. The first and second sideband fields are used in a method for limiting a number of writes to the write-many memory device. Other preferred embodiments are provided, and each of the preferred embodiments can be used alone or in combination with one another.

(52) **U.S. Cl.** **711/103**

(58) **Field of Classification Search** **711/103, 711/154, 163**

See application file for complete search history.

(56) **References Cited**

U.S. PATENT DOCUMENTS

5,153,462 A	10/1992	Agrawal et al.	
5,264,740 A	11/1993	Wright	
5,414,829 A	5/1995	Fandrich et al.	
5,734,816 A *	3/1998	Nijima et al.	395/182.06
5,737,742 A *	4/1998	Achiwa et al.	711/103
6,034,882 A	3/2000	Johnson et al.	
6,058,047 A *	5/2000	Kikuchi 365/185.33	
6,134,141 A	10/2000	Wong	
6,151,246 A	11/2000	So et al.	
6,181,603 B1	1/2001	Jyouno et al.	
6,219,282 B1	4/2001	Tanaka	

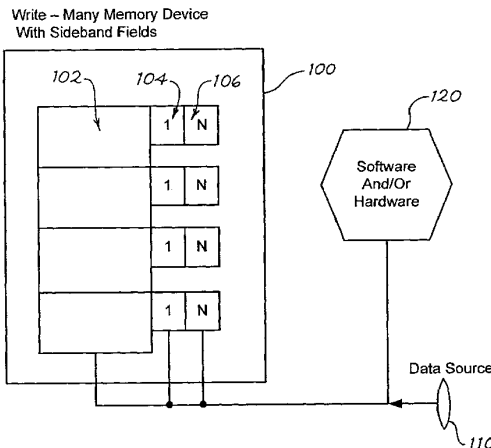

45 Claims, 3 Drawing Sheets

OTHER PUBLICATIONS

“How Does TrueFFS® manage Wear Leveling?,” <http://www.m-sys.com/content/information/calInfo.asp>, 2 pages (printed Oct. 5, 2001).

“Intel StrataFlash™ Memory Technology Development and Implementation,” Fazio et al., Intel Technology Journal, 13 pages (Q4'1997).

“A 125mm² 1Gb NAND Flash Memory with 10MB/s Program Throughput,” Nakamura et al., ISSCC 2002/Session 6/SRAM and Non-Volatile Memories/6.4, 2002 IEEE International Solid-State Circuits Conference, Digest of Technical Papers, pp. 106-107 (2002).

“On the Go With Sonos,” White et al., Circuits & Devices, pp. 22-31 (Jul. 2000).

“NROM: A Novel Localized Trapping, 2-Bit Nonvolatile Memory Cell,” Eitan et al., IEEE Electron Device Letters, vol. 21, No. 11, pp. 543-545 (Nov. 2000).

“A 512Mb NROM Flash Data Storage Memory with 8MB/s Data Rate,” Maayan et al., ISSCC 2002/Session 6/SRAM and Non-Volatile Memories/6.1, 2002 IEEE International Solid-State Circuits Conference, Digest of Technical Papers, pp. 100-101 (2002).

“Ovonic Unified Memory—A High-Performance Nonvolatile Memory Technology for Stand-Alone Memory and Embedded Applications,” Gill et al., ISSCC 2002/Session 12/TD Digital Directions/12.4, 2002 IEEE International Solid-State Circuits Conference, Digest of Technical Papers, pp. 202-203 (2002).

“0.13 μm Metal-Oxide-Nitride-Oxide-Semiconductor Single Transistor Memory Cell with Separated Source Line,” Fujiwara et al., Jpn. J. Appl. Phys. vol. 39, pp. 417-423, Part 1, No. 2A (Feb. 2000).

“Three-Dimensional Memory Array and Method of Fabrication,” U.S. Appl. No. 09/560,626, filed Apr. 28, 2000, inventor: N. Johan Knall.

“Digital Memory Method and System for Storing Multiple-Bit Digital Data,” U.S. Appl. No. 09/932,701, filed Aug. 17, 2001, inventors: Michael A. Vyvoda and N. Johan Knall.

“Memory Device and Method for Reliably Reading Multi-Bit Data from a Write-Many Memory Cell,” U.S. Appl. No. 10/144,451, filed May 9, 2002, inventor: Bendik Kleveland.

* cited by examiner

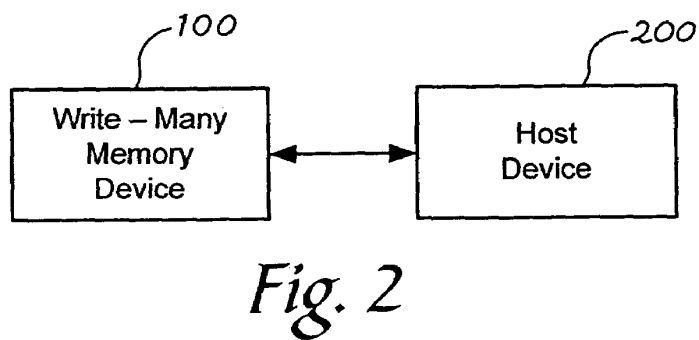
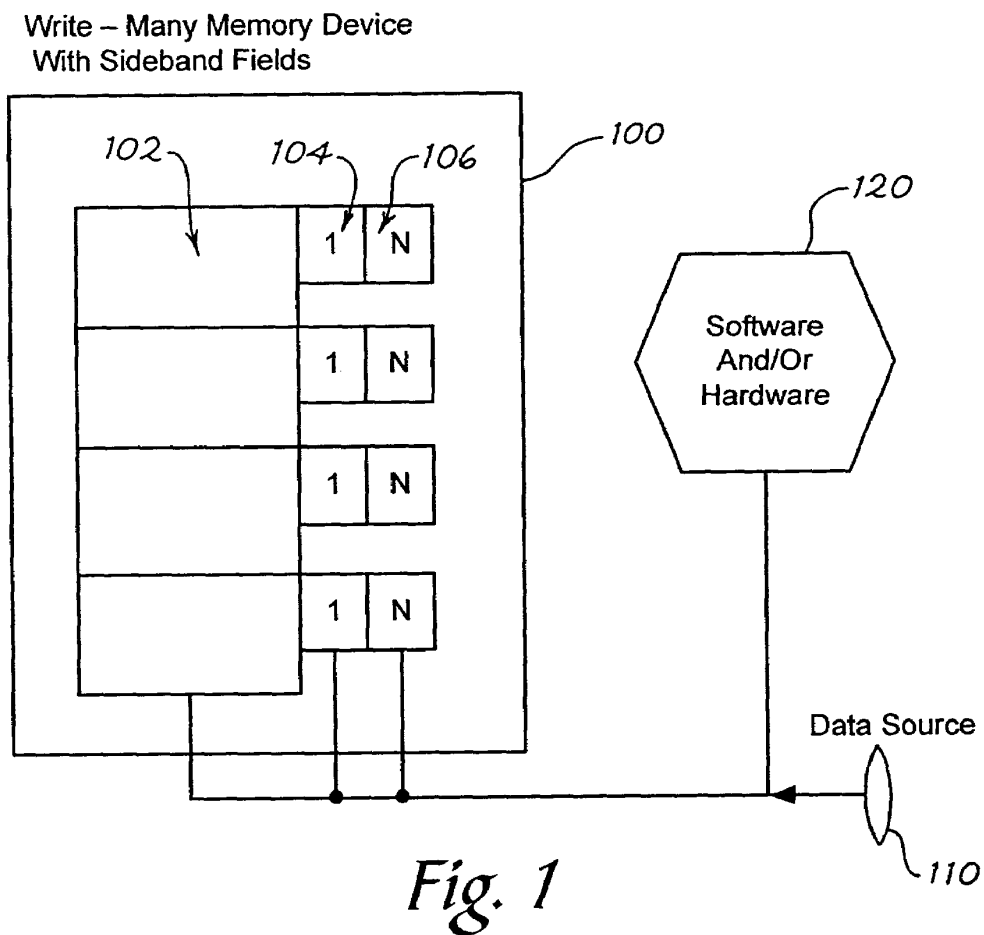

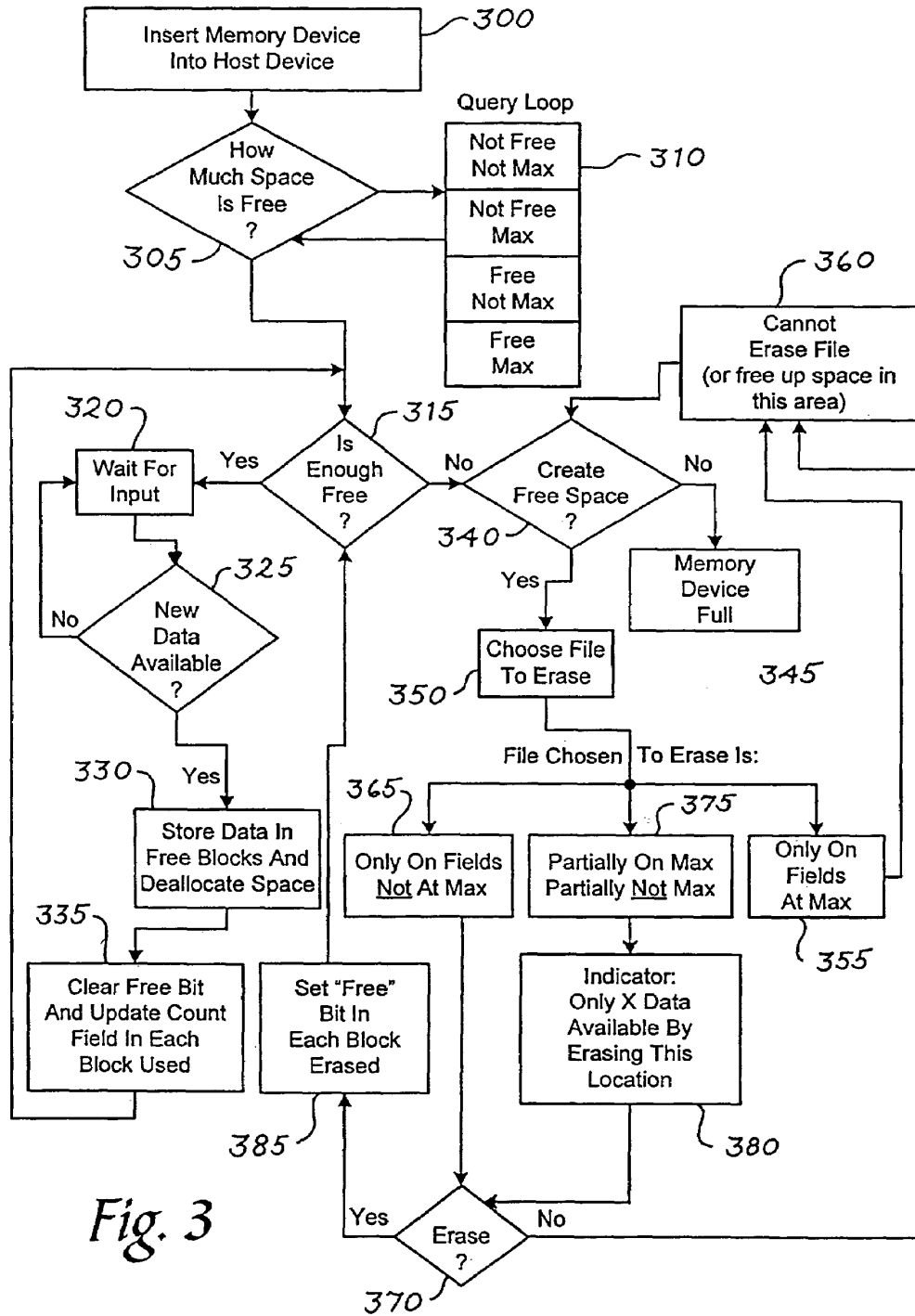

Fig. 3

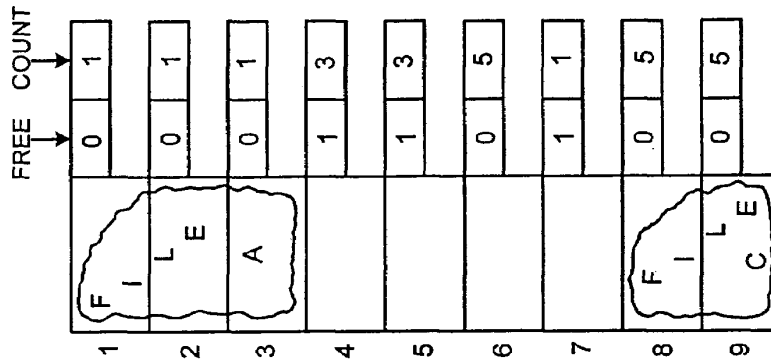

Fig. 4A

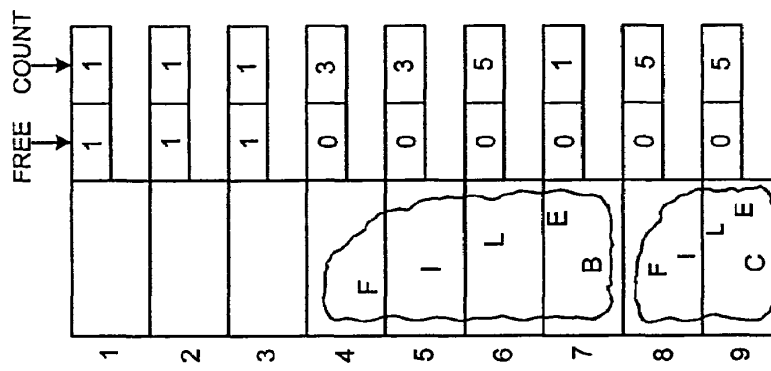

Fig. 4B

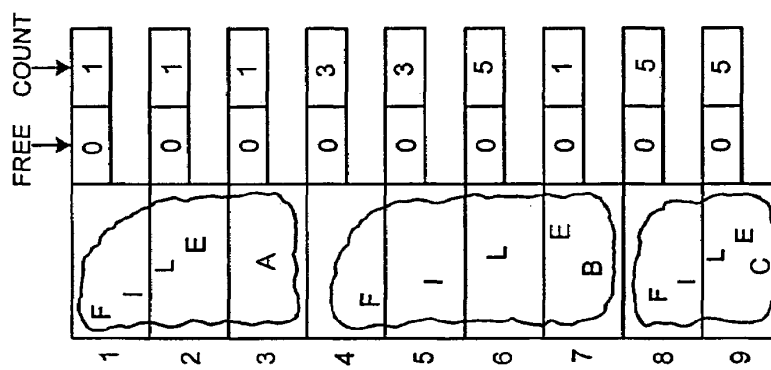

Fig. 4C

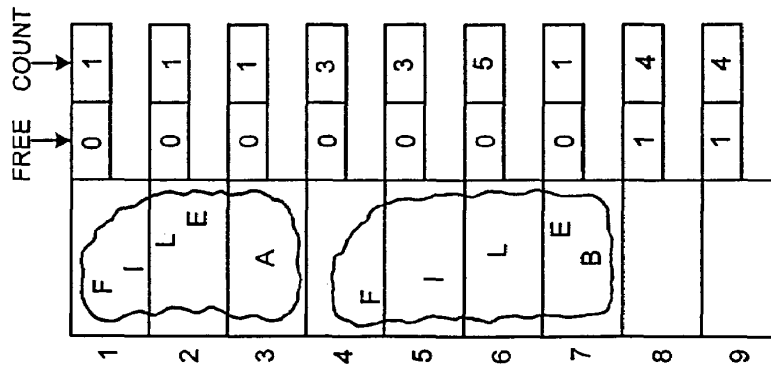

Fig. 4D

Explore Litigation Insights

Docket Alarm provides insights to develop a more informed litigation strategy and the peace of mind of knowing you're on top of things.

Real-Time Litigation Alerts



Keep your litigation team up-to-date with **real-time alerts** and advanced team management tools built for the enterprise, all while greatly reducing PACER spend.

Our comprehensive service means we can handle Federal, State, and Administrative courts across the country.

Advanced Docket Research



With over 230 million records, Docket Alarm's cloud-native docket research platform finds what other services can't. Coverage includes Federal, State, plus PTAB, TTAB, ITC and NLRB decisions, all in one place.

Identify arguments that have been successful in the past with full text, pinpoint searching. Link to case law cited within any court document via Fastcase.

Analytics At Your Fingertips



Learn what happened the last time a particular judge, opposing counsel or company faced cases similar to yours.

Advanced out-of-the-box PTAB and TTAB analytics are always at your fingertips.

API

Docket Alarm offers a powerful API (application programming interface) to developers that want to integrate case filings into their apps.

LAW FIRMS

Build custom dashboards for your attorneys and clients with live data direct from the court.

Automate many repetitive legal tasks like conflict checks, document management, and marketing.

FINANCIAL INSTITUTIONS

Litigation and bankruptcy checks for companies and debtors.

E-DISCOVERY AND LEGAL VENDORS

Sync your system to PACER to automate legal marketing.