



US007917709B2

(12) **United States Patent**
Gorobets

(10) **Patent No.:** **US 7,917,709 B2**
(45) **Date of Patent:** ***Mar. 29, 2011**

(54) **MEMORY SYSTEM FOR DATA STORAGE AND RETRIEVAL**

(75) Inventor: **Sergey Anatolievich Gorobets**,
Edinburgh (DE)

(73) Assignee: **Lexar Media, Inc.**, Fremont, CA (US)

(*) Notice: Subject to any disclaimer, the term of this patent is extended or adjusted under 35 U.S.C. 154(b) by 0 days.

This patent is subject to a terminal disclaimer.

4,210,959 A 7/1980 Wozniak
4,309,627 A 1/1982 Tabata
4,355,376 A 10/1982 Gould
4,398,248 A 8/1983 Hsia et al.
4,405,952 A 9/1983 Slakmon
4,414,627 A 11/1983 Nakamura
4,450,559 A 5/1984 Bond et al.
4,456,971 A 6/1984 Fukuda et al.
4,468,730 A 8/1984 Dodd et al.
4,473,878 A 9/1984 Zolnowsky et al.
4,476,526 A 10/1984 Dodd

(Continued)

FOREIGN PATENT DOCUMENTS

AU 0 557 723 1/1987

(Continued)

(21) Appl. No.: **12/638,572**

(22) Filed: **Dec. 15, 2009**

(65) **Prior Publication Data**

US 2010/0095055 A1 Apr. 15, 2010

Related U.S. Application Data

(63) Continuation of application No. 10/256,891, filed on Sep. 27, 2002, now Pat. No. 7,634,624.

(30) **Foreign Application Priority Data**

Sep. 28, 2001 (GB) 0123410.3

(51) **Int. Cl.**
G06F 13/00 (2006.01)

(52) **U.S. Cl.** 711/154; 711/159

(58) **Field of Classification Search** 711/156,
711/159

See application file for complete search history.

(56) **References Cited**

U.S. PATENT DOCUMENTS

4,099,069 A 7/1978 Cricchi et al.
4,130,900 A 12/1978 Watanabe

OTHER PUBLICATIONS

Kai Hwang & Faye A. Briggs, *Computer Architecture and Parallel Processing*, McGraw-Hill Book Co., 1984, p. 64.

(Continued)

Primary Examiner — Hetul Patel

(74) *Attorney, Agent, or Firm* — Leffert Jay & Polglaze, P.A.

(57) **ABSTRACT**

According to a first aspect of an embodiment of the invention, there is provided a method of data storage and retrieval for use in a solid state memory system, having a non-volatile memory, wherein data is written to the non-volatile memory in the form of at least one logical sector the method comprising: monitoring the logical sector data which is to be written to the non-volatile memory, detecting the presence of a pattern in the logical sector data, upon detecting a repetitive pattern recording the repetitive pattern of the logical sector in a sector address table in the non-volatile memory without making a record of the logical sector data in the nonvolatile memory.

25 Claims, 5 Drawing Sheets

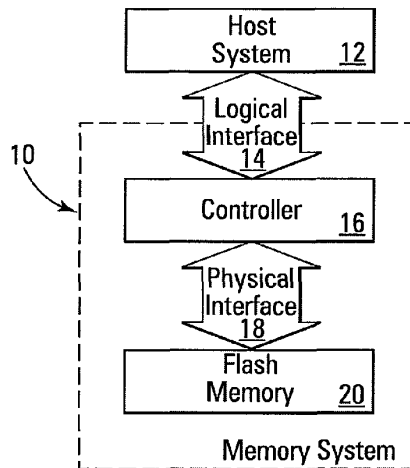

U.S. PATENT DOCUMENTS		
4,498,146 A	2/1985	Martinez
4,525,839 A	6/1985	Nozawa et al.
4,532,590 A	7/1985	Wallach et al.
4,609,833 A	9/1986	Gutterman
4,616,311 A	10/1986	Sato
4,654,847 A	3/1987	Dutton
4,710,871 A	12/1987	Belknap et al.
4,746,998 A	5/1988	Robinson et al.
4,748,320 A	5/1988	Yorimoto et al.
4,757,474 A	7/1988	Fukushi et al.
4,774,700 A	9/1988	Satoh et al.
4,780,855 A	10/1988	Iida et al.
4,788,665 A	11/1988	Fukuda et al.
4,797,543 A	1/1989	Watanabe
4,800,520 A	1/1989	Iijima
4,829,169 A	5/1989	Watanabe
4,843,224 A	6/1989	Ohta et al.
4,845,662 A	7/1989	Tokumitsu
4,896,262 A	1/1990	Wayama et al.
4,914,529 A	4/1990	Bonke
4,920,518 A	4/1990	Nakamura et al.
4,924,331 A	5/1990	Robinson et al.
4,943,745 A	7/1990	Watanabe et al.
4,953,122 A	8/1990	Williams
4,970,642 A	11/1990	Yamamura
4,970,727 A	11/1990	Miyawaki et al.
5,070,474 A	12/1991	Tuma et al.
5,093,785 A	3/1992	Iijima
5,168,465 A	12/1992	Harari
5,198,380 A	3/1993	Harari
5,200,959 A	4/1993	Gross et al.
5,218,695 A	6/1993	Noveck et al.
5,220,518 A	6/1993	Haq
5,226,168 A	7/1993	Kobayashi et al.
5,227,714 A	7/1993	Lou
5,253,351 A	10/1993	Yamamoto et al.
5,267,218 A	11/1993	Elbert
5,268,318 A	12/1993	Harari
5,268,870 A	12/1993	Harari
5,270,979 A	12/1993	Harari et al.
5,293,560 A	3/1994	Harari
5,297,148 A	3/1994	Harari et al.
5,303,198 A	4/1994	Adachi et al.
5,305,276 A	4/1994	Uenoyama
5,305,278 A	4/1994	Inoue
5,315,541 A	5/1994	Harari et al.
5,315,558 A	5/1994	Hag
5,329,491 A	7/1994	Brown et al.
5,337,275 A	8/1994	Garner
5,341,330 A	8/1994	Wells et al.
5,341,339 A	8/1994	Wells
5,341,341 A	8/1994	Fukuzo
5,353,256 A	10/1994	Fandrich et al.
5,357,475 A	10/1994	Hasbun et al.
5,359,569 A	10/1994	Fujita et al.
5,365,127 A	11/1994	Manley
5,369,615 A	11/1994	Harari et al.
5,371,702 A	12/1994	Nakai et al.
5,381,539 A	1/1995	Yanai et al.
5,382,839 A	1/1995	Shinohara
5,384,743 A	1/1995	Rouy
5,388,083 A	2/1995	Assar et al.
5,396,468 A	3/1995	Harari et al.
5,404,485 A	4/1995	Ban
5,406,527 A	4/1995	Honma
5,418,752 A	5/1995	Harari et al.
5,422,842 A	6/1995	Cernea et al.
5,422,856 A	6/1995	Sasaki et al.
5,428,621 A	6/1995	Mehrotra et al.
5,430,682 A	7/1995	Ishikawa et al.
5,430,859 A	7/1995	Norman et al.
5,431,330 A	7/1995	Wieres
5,434,825 A	7/1995	Harari
5,438,573 A	8/1995	Mangan et al.
5,465,235 A	11/1995	Miyamoto
5,465,338 A	11/1995	Clay
5,471,478 A	11/1995	Mangan et al.
5,473,765 A	12/1995	Gibbons et al.
5,479,638 A	12/1995	Assar et al.
5,485,595 A	1/1996	Assar et al.
5,490,117 A	2/1996	Oda et al.
5,495,442 A	2/1996	Cernea et al.
5,504,760 A	4/1996	Harari et al.
5,508,971 A	4/1996	Cernea et al.
5,513,138 A	4/1996	Manabe et al.
5,515,333 A	5/1996	Fujita et al.
5,519,847 A	5/1996	Fandrich et al.
5,523,980 A	6/1996	Sakui et al.
5,524,230 A	6/1996	Sakaue et al.
5,530,673 A	6/1996	Tobita et al.
5,530,828 A	6/1996	Kaki et al.
5,530,938 A	6/1996	Akasaka et al.
5,532,962 A	7/1996	Auclair et al.
5,532,964 A	7/1996	Cernea et al.
5,534,456 A	7/1996	Yuan et al.
5,535,328 A	7/1996	Harari et al.
5,541,551 A	7/1996	Brehner et al.
5,544,118 A	8/1996	Harari
5,544,356 A	8/1996	Robinson et al.
5,552,698 A	9/1996	Tai et al.
5,554,553 A	9/1996	Harari
5,563,825 A	10/1996	Cernea et al.
5,566,314 A	10/1996	DeMarco et al.
5,568,439 A	10/1996	Harari
5,572,466 A	11/1996	Sukegawa
5,579,502 A	11/1996	Konishi et al.
5,581,723 A	12/1996	Hasbun et al.
5,583,812 A	12/1996	Harari
5,592,415 A	1/1997	Kato et al.
5,592,420 A	1/1997	Cernea et al.
5,596,526 A	1/1997	Assar et al.
5,598,370 A	1/1997	Nijijima et al.
5,600,316 A	2/1997	Moll
5,602,987 A	2/1997	Harari et al.
5,603,001 A	2/1997	Sukegawa et al.
5,606,660 A	2/1997	Estakhri et al.
5,611,067 A	3/1997	Okamoto et al.
5,640,528 A	6/1997	Harney et al.
5,642,312 A	6/1997	Harari
5,648,929 A	7/1997	Miyamoto
5,663,901 A	9/1997	Wallace et al.
5,693,570 A	12/1997	Cernea et al.
5,712,819 A	1/1998	Harari
5,719,808 A	2/1998	Harari et al.
5,723,990 A	3/1998	Roohparvar
5,734,567 A	3/1998	Griffiths et al.
5,745,418 A	4/1998	Ma et al.
5,754,567 A	5/1998	Norman
5,757,712 A	5/1998	Nagel et al.
5,758,100 A	5/1998	Odisho
5,761,117 A	6/1998	Uchino et al.
5,768,190 A	6/1998	Tanaka et al.
5,768,195 A	6/1998	Nakamura et al.
5,773,901 A	6/1998	Kantner
5,778,418 A	7/1998	Auclair et al.
5,781,478 A	7/1998	Takeuchi et al.
5,787,445 A	7/1998	Daberko
5,787,484 A	7/1998	Norman
RE35,881 E	8/1998	Barrett et al.
5,799,168 A	8/1998	Ban
5,802,551 A	9/1998	Komatsu et al.
5,809,515 A	9/1998	Kaki et al.
5,809,558 A	9/1998	Matthews et al.
5,809,560 A	9/1998	Schneider
5,818,350 A	10/1998	Estakhri et al.
5,818,781 A	10/1998	Estakhri et al.
5,822,245 A	10/1998	Gupta et al.
5,822,252 A	10/1998	Lee et al.
5,822,781 A	10/1998	Wells et al.
5,831,929 A	11/1998	Manning
5,835,935 A	11/1998	Estakhri et al.
5,838,614 A	11/1998	Estakhri et al.
5,845,313 A	12/1998	Estakhri et al.
5,847,552 A	12/1998	Brown
5,860,083 A	1/1999	Sukegawa
5,860,124 A	1/1999	Matthews et al.
5,862,099 A	1/1999	Gannage et al.

5,890,192 A	3/1999	Lee et al.	6,711,059 B2	3/2004	Sinclair et al.
5,901,086 A	5/1999	Wang et al.	6,721,819 B2	4/2004	Estakhri et al.
5,907,856 A	5/1999	Estakhri et al.	6,721,843 B1	4/2004	Estakhri
5,909,586 A	6/1999	Anderson	6,725,321 B1	4/2004	Sinclair et al.
5,920,884 A	7/1999	Jennings, III et al.	6,725,342 B1	4/2004	Coulson
5,924,113 A	7/1999	Estakhri et al.	6,728,851 B1	4/2004	Estakhri et al.
5,928,370 A	7/1999	Asnaashari	6,751,155 B2	6/2004	Gorobets
5,930,815 A	7/1999	Estakhri et al.	6,757,800 B1	6/2004	Estakhri et al.
5,933,368 A	8/1999	Ma et al.	6,813,678 B1	11/2004	Sinclair et al.
5,933,846 A	8/1999	Endo	6,898,662 B2	5/2005	Gorobets
5,936,971 A	8/1999	Harari et al.	6,912,618 B2	6/2005	Estakhri et al.
5,937,425 A	8/1999	Ban	6,950,918 B1	9/2005	Estakhri
5,953,737 A	9/1999	Estakhri et al.	6,957,295 B1	10/2005	Estakhri
5,956,473 A	9/1999	Ma et al.	6,973,519 B1	12/2005	Estakhri et al.
5,959,926 A	9/1999	Jones et al.	6,978,342 B1	12/2005	Estakhri et al.
5,966,727 A	10/1999	Nishino	7,000,064 B2	2/2006	Payne et al.
5,986,933 A	11/1999	Takeuchi et al.	2003/0033471 A1	2/2003	Lin et al.
5,987,563 A	11/1999	Itoh et al.			
5,987,573 A	11/1999	Hiraka			
5,991,847 A	11/1999	Ballard et al.			
5,991,849 A	11/1999	Yamada et al.			
6,000,006 A	12/1999	Bruce et al.			
6,011,322 A	1/2000	Stumfall et al.			
6,011,323 A	1/2000	Camp			
6,018,265 A	1/2000	Keshtbod			
6,021,408 A	2/2000	Ledain et al.			
6,026,020 A	2/2000	Matsubara et al.			
6,026,027 A	2/2000	Terrell, II et al.			
6,034,897 A	3/2000	Estakhri et al.			
6,035,357 A	3/2000	Sakaki			
6,040,997 A	3/2000	Estakhri			
6,041,001 A	3/2000	Estakhri			
6,047,352 A	4/2000	Lakhani et al.			
6,055,184 A	4/2000	Acharya et al.			
6,055,188 A	4/2000	Takeuchi et al.			
6,069,827 A	5/2000	Sinclair			
6,072,796 A	6/2000	Christensen et al.			
6,076,137 A	6/2000	Asnaashari			
6,081,447 A	6/2000	Lofgren et al.			
6,081,878 A	6/2000	Estakhri et al.			
6,084,483 A	7/2000	Keshtbod			
6,097,666 A	8/2000	Sakui et al.			
6,115,785 A	9/2000	Estakhri et al.			
6,122,195 A	9/2000	Estakhri et al.			
6,125,424 A	9/2000	Komatsu et al.			
6,125,435 A	9/2000	Estakhri et al.			
6,128,695 A	10/2000	Estakhri et al.			
6,134,145 A	10/2000	Wong			
6,134,151 A	10/2000	Estakhri et al.			
6,141,249 A	10/2000	Estakhri et al.			
6,145,051 A	11/2000	Estakhri et al.			
6,151,247 A	11/2000	Estakhri et al.			
6,172,906 B1	1/2001	Estakhri et al.			
6,173,362 B1	1/2001	Yoda			
6,181,118 B1	1/2001	Meehan et al.			
6,182,162 B1	1/2001	Estakhri et al.			
6,202,138 B1	3/2001	Estakhri et al.			
6,223,308 B1	4/2001	Estakhri et al.			
6,226,708 B1	5/2001	McGoldrick et al.			
6,230,234 B1	5/2001	Estakhri et al.			
6,262,918 B1	7/2001	Estakhri et al.			
6,272,610 B1	8/2001	Katayama et al.			
6,275,436 B1	8/2001	Tobita et al.			
6,279,069 B1	8/2001	Robinson et al.			
6,279,114 B1	8/2001	Toombs et al.			
6,285,607 B1	9/2001	Sinclair			
6,327,639 B1	12/2001	Asnaashari			
6,345,367 B1	2/2002	Sinclair			
6,374,337 B1	4/2002	Estakhri			
6,385,667 B1	5/2002	Estakhri et al.			
6,393,513 B2	5/2002	Estakhri et al.			
6,397,314 B1	5/2002	Estakhri et al.			
6,411,546 B1	6/2002	Estakhri et al.			
6,467,021 B1	10/2002	Sinclair			
6,490,649 B2	12/2002	Sinclair			
6,567,307 B1	5/2003	Estakhri			
6,571,318 B1	5/2003	Sander et al.			
6,578,127 B1	6/2003	Sinclair			
6,587,382 B1	7/2003	Estakhri et al.			
			EP	0 220 718 A2	5/1987
			EP	0 243 503 A1	11/1987
			EP	0 392 895 A2	10/1990
			EP	0 424 191 A2	4/1991
			EP	0 489 204 A1	6/1992
			EP	0 522 780 A2	1/1993
			EP	0 522 780 B1	1/1993
			EP	0 544 252 A2	6/1993
			EP	0 613 151 A2	8/1994
			EP	0 617 363 A2	9/1994
			EP	0 619 541 A2	10/1994
			EP	0 663 636 A1	7/1995
			EP	0 686 976 A2	12/1995
			EP	0 897 579 B1	7/2000
			EP	0 891 580 B1	11/2000
			EP	0 896 669 B1	11/2000
			EP	0 852 766 B1	5/2001
			EP	0 852 765 B1	9/2001
			EP	0 722 585 B1	5/2002
			EP	0 910 826 B1	6/2002
			EP	0 691 008 B1	11/2002
			EP	0 861 468 B1	4/2003
			EP	0 978 040 B1	5/2004
			EP	1 157 328 B1	5/2005
			FR	93 01908	8/1993
			GB	2 251 323	7/1992
			GB	2 291 990	2/1996
			GB	2 291 991	2/1996
			GB	2 297 637	7/1996
			GB	2 304 428	3/1997
			GB	2 348 991	12/2002
			GB	2 351 822	1/2003
			GB	2 384 337	7/2003
			GB	2 384 883	10/2005
			GB	2 384 338	11/2005
			GB	2 384 072	12/2005
			GB	2 411 499	2/2006
			IS	117881	5/2003
			JP	59-45695	9/1982
			JP	58-21594	12/1983
			JP	58-21595	12/1983
			JP	59-162695	9/1984
			JP	60-212900	10/1985
			JP	61-96598	5/1986
			JP	62-283496	12/1987
			JP	62-283497	12/1987
			JP	63-183700	7/1988
			JP	1-138694	5/1989
			JP	3-228377	10/1991
			JP	4-57295	2/1992
			JP	4-254994	9/1992
			JP	4-298284	9/1992
			JP	4-278297	10/1992
			JP	4-332999	11/1992
			JP	5-128877	5/1993
			JP	5-282883	10/1993
			JP	6-36578	2/1994
			JP	6-124175	5/1994
			JP	6-124231	5/1994
			JP	6-132747	5/1994

FOREIGN PATENT DOCUMENTS

JP	6-149395	5/1994
JP	6-131889	6/1994
JP	6-266596	9/1994
JP	7-93499	4/1995
JP	7-311708	11/1995
JP	8-18018	1/1996
JP	8-69696	3/1996
JP	9-147581	6/1997
SU	1388877	4/1988
SU	1408439	7/1988
SU	1515164	10/1989
SU	1541619	2/1990
SU	1573458	6/1990
SU	1686449	10/1991
WO	WO 84/00628	2/1984
WO	WO 94/20906	9/1994

OTHER PUBLICATIONS

- Walter Lahti and Dean McCarron, "State of the Art: Magnetic VS Optical Store Data in a Flash", *Byte Magazine*, Nov. 1, 1990, 311, vol. 15, No. 12.
- Ron Wilson, Technology Updates, Integrated Circuits, "1-Mbit flash memories seek their role in system design", *Computer Design* 28 Mar. 1, 1989, No. 5, Tulsa OK, US, pp. 30 and 32.
- Mendel Rosenblum and John K. Ousterhout, "The Design and Implementation of a Log-Structured File System," 1991, 15 pgs., Berkeley, USA.
- Brian Dipert and Markus Levy, *Designing with Flash Memory*, Annabooks, Apr. 1994, 445 pgs.
- Science Forum, Inc. "Flash Memory Symposium '95", 1995, 13 pgs. Tokyo.
- Ross S. Finlayson and David R. Cheriton, "An Extended File Service Exploiting Write-Once Storage," *ACM Symposium on Operating Systems Principles*, 1987, 10 pgs.
- Jason Gait, "The Optical File Cabinet: A Random-Access File System for Write-Once Storage", *Computer*, Jun. 1988, 12 pgs.
- Henry G. Baker, *Memory Management*, 1995, Springer-Verlag Heidelberg, Germany, 19 pgs.
- Sape J. Mullender and Andrew S. Tanenbaum, "A Distributed File Service Based on Optimistic Concurrency Control", *ACM Press*, 1985, 12 pgs. New York, New York.
- Hiroshi Nakamura, Junichi Miyamoto, Kenichi Imamiya and Yoshihisa Iwata, "A Novel Sense Amplifier for Flexible Voltage Operation NAND Flash Memories", *VLSI Circuits*, 1995, *Digest of Technical Papers*, 2 pgs.
- Hiroshi Nakamura, Junichi Miyamoto, Kenichi Imamiya, Yoshihisa Iwata and Hideko Oodaira, "A Novel Sensing Scheme with On-Chip Page Copy for Flexible Voltage NAND Flash Memories", *IEICE Transactions on Electronics*, vol. E79-C, No. 6, pp. 836-844.
- Takaaki Nozaki, Toshiaki Tanaka, Yoshiro Kijiyu, Eita Kinoshita, Tatsuo Tsuchiya and Yutaka Hayashi, "A 1-Mb EEPROM with MONOS Memory Cell for Semiconductor Disk Application", *Journal of Solid-State Circuits*, vol. 26, No. 4, 5 pgs.
- S. Mehroua, J.H. Yuan, R.A. Cemea, W.Y. Chien, D.C. Guteman, G. Samachisa, R.D. Norman, M. Mofidi, W. Lee, Y. Fong, A. Mihnea, E. Hann, R.W. Gregor, E.P. Eberhardt, J.R. Radosevich, K.R. Stiles, R.A. Kohler, C.W. Leung, and T.J. Mulrooney, "Serial 9Mb F EEPROM for Solid State Disk Applications", symposium, 2 pgs., 1992, Mountain View, CA.
- Steven H. Leibson, "Nonvolatile, In-Circuit-Reprogrammable Memories", *EDN Special Report*, Jan. 3, 1991, No. 12, 12 pgs.
- Walter Lahti and Dean McCarron, "State of the Art: Magnetic vs. Optical Store Data in a Flash", *Byte Magazine*, 1990, vol. 15, No. 12, 7 pgs.
- Ramon Caceres, Fred Douglis, Kai Li and Brian Marsh, "Operating System Implications of Solid-State Mobile Computers", *Workshop on Workstation Operating Systems*, Oct. 1993, pp. 21-27.
- Michael Wu and Wily Zwaenepool, "A Non-Volatile, Main Memory Storage System", *ACM Press*, 1994, 12 pgs., San Jose, CA.
- Dave Bursky, "Innovative flash memories match DRAM densities: available with a choice of features, flash memories are finding homes in many systems (including related articles on the origins of flash, and on the differences between NAND and NOR flash memories)", *Electronic Design*, May 16, 1994, vol. 42, No. 10, 9 pgs.
- Anthony Cataldo, "New flash enhancements up ante. (Intel's 28F400BV-120 and 28F004BV-120, Atmel's AT29BV010 and AT29BV020, and Samsung Semiconductor's KM29V3200 flash memory devices)" (product announcement), *Electronic News*, Mar. 13, 1995, vol. 41, No. 2056, 4 pgs.
- Sam Weber, "Flash modules' portability, reusability, small size valued for a host of APPs-Consumer formats flocking to flash", *Electronic Engineering Times*, Jul. 22, 1996, No. 911, 9 pgs.
- Stan Baker, "But Integration Calls for Hardware, Software Changes: Flash designers face the dawn of a new memory age", *Electronic Engineering Times*, Dec. 3, 1990, vol. 41, No. 619, 5 pgs.
- Toshiba, MOS Memory (Non-Volatile), 1995, Data Book.
- Toshiba, Toshiba MOS Digital Integrated Circuit Silicon Gate CMOS, (TC58NS512DC), Mar. 21, 2001, 43 pgs., Data Book.
- Toshiba, Toshiba Corporation, SMIL (Smartmedia Interface Library) Hardware Edition Version 1.00, Jul. 1, 2000, 136 pgs., Data Book.
- Toshiba, Toshiba MOS Digital Integrated Circuit Silicon Gate, (TC58512FT), Mar. 5, 2001, 43 pgs., Data Book.
- Toshiba, Toshiba MOS Digital Integrated Circuit Silicon Gate, (TC58DVM92A1FT00), Jan. 10, 2003, 44 pgs., Data Book.
- Toshiba, Toshiba MOS Digital Integrated Circuit Silicon Gate, (TC58DVG02A1FT00), Jan. 10, 2003, 44 pgs., Data Book.
- Toshiba, Toshiba MOS Digital Integrated Circuit Silicon Gate, (TC58100FT), Mar. 5, 2001, 43 pgs., Data Book.
- Toshiba, MOS Memory (Non-Volatile), 1996, 279 pgs., Data Book.
- "Fifth Biennial Nonvolatile Memory Technology Review," 1993 Conference, Jun. 22-24, 1993, Linthicum Heights, MD, USA.
- Dan Auclair, "Optimal Solid State Disk Architecture For Portable Computers", Silicon Valley PC Design Conference, Jul. 9-10, 1991, pp. 811-815.

FIG. 1
Prior Art

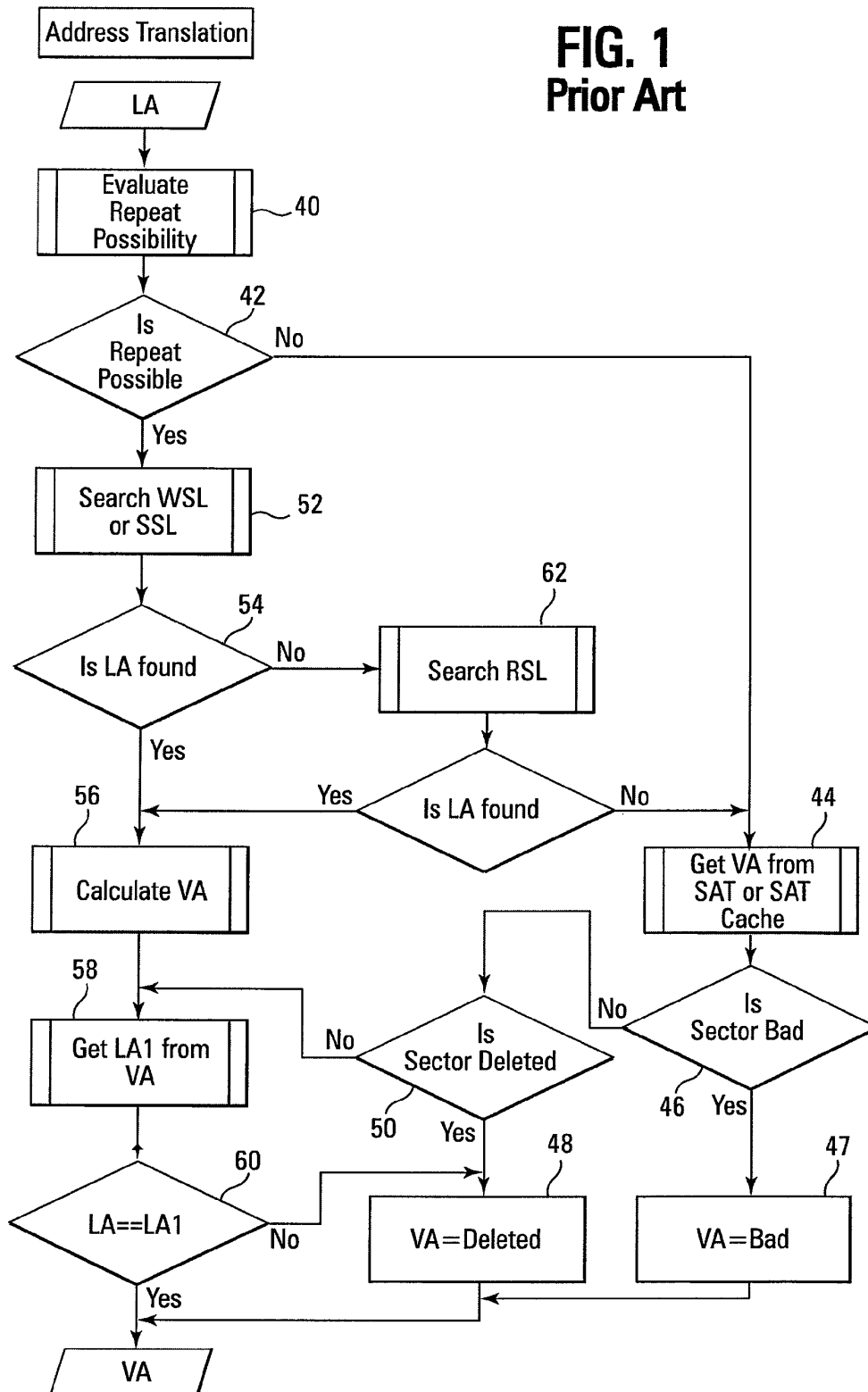

Explore Litigation Insights

Docket Alarm provides insights to develop a more informed litigation strategy and the peace of mind of knowing you're on top of things.

Real-Time Litigation Alerts



Keep your litigation team up-to-date with **real-time alerts** and advanced team management tools built for the enterprise, all while greatly reducing PACER spend.

Our comprehensive service means we can handle Federal, State, and Administrative courts across the country.

Advanced Docket Research



With over 230 million records, Docket Alarm's cloud-native docket research platform finds what other services can't. Coverage includes Federal, State, plus PTAB, TTAB, ITC and NLRB decisions, all in one place.

Identify arguments that have been successful in the past with full text, pinpoint searching. Link to case law cited within any court document via Fastcase.

Analytics At Your Fingertips



Learn what happened the last time a particular judge, opposing counsel or company faced cases similar to yours.

Advanced out-of-the-box PTAB and TTAB analytics are always at your fingertips.

API

Docket Alarm offers a powerful API (application programming interface) to developers that want to integrate case filings into their apps.

LAW FIRMS

Build custom dashboards for your attorneys and clients with live data direct from the court.

Automate many repetitive legal tasks like conflict checks, document management, and marketing.

FINANCIAL INSTITUTIONS

Litigation and bankruptcy checks for companies and debtors.

E-DISCOVERY AND LEGAL VENDORS

Sync your system to PACER to automate legal marketing.