

Designing with FLASH MEMORY

Brian Dipert and Markus Levy

The definitive guide to
designing flash memory
hardware and software
for components and
PCMCIA cards.



Designing with Flash Memory

*The definitive guide to
designing flash memory
hardware and software
for components and
PCMCIA cards*

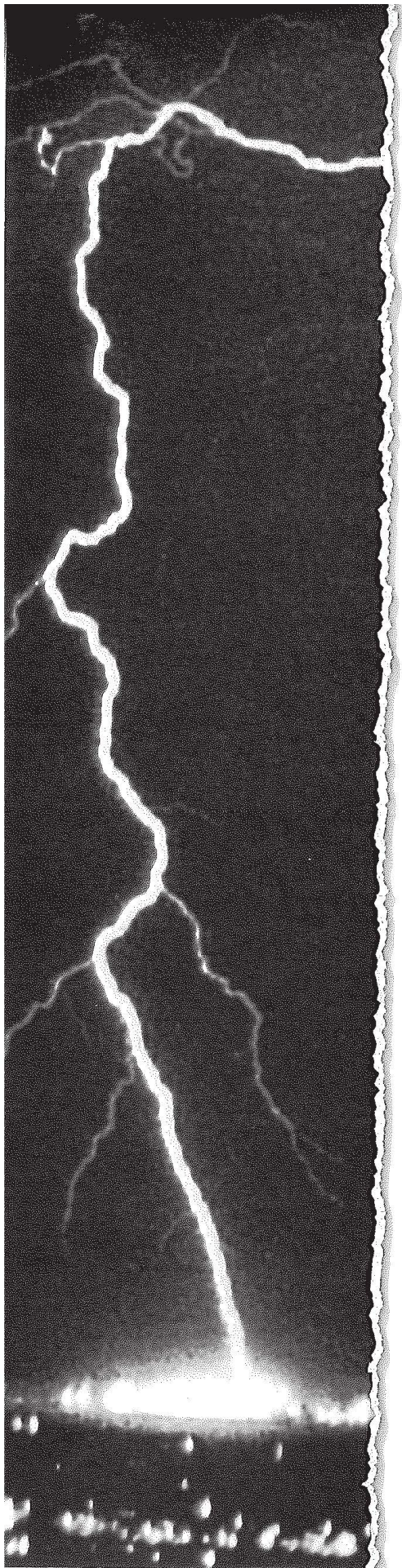

Designing with Flash Memory

Brian Dipert & Markus Levy

*The definitive guide to
designing flash memory
hardware and software
for components and
PCMCIA cards*

*Annabooks
San Diego*

Designing with Flash Memory

BY

BRIAN DIPERT & MARKUS LEVY

PUBLISHED BY

Annabooks
11848 Bernardo Plaza Ct., Suite 110
San Diego, CA 92128
USA

619-673-0870

Copyright © Annabooks 1993, 1994

All rights reserved. No part of the contents of this book may be reproduced or transmitted in any form or by any means without the prior written permission of the publisher, except for the inclusion of brief quotations in a review.

Printed in the United States of America

ISBN 0-929392-17-5
Second Printing April 1994

Contents

Chapter One: Introduction	1
Flash Memory Compared to Other Memories	3
ROM (Read-Only-Memory)	4
RAM (Random-Access-Memory)	4
EEPROM (Electrically-Eraseable-Programmable-Read-Only-Memory)	5
Magnetic Mass Storage	5
An Emerging Alternative: Flash Memory	5
A Preview of Chapters to Follow	7
Chapter Two: Flash Memory Applications	11
Data Accumulation	12
Medical Instrumentation	12
Flight Recorders	13
More Data Accumulation Examples	13
Why Flash Memory for Data Acquisition?	14
Data/Lookup Table Storage	14
PBX Switcher	14
Laser Printers	15
Why Flash Memory For Data/Lookup Table Storage?	16
Embedded Code Storage	16
PC BIOS	16
Digital Cellular Phones	18
More Embedded Code Storage Applications	18
Why Flash Memory for Embedded Code Storage?	18
File Storage	19
Flash Memory Promotes Longer Battery Life	19
HDD Densities with FDD Interchange	20
Summary	21
Chapter Three: Flash Memory Technologies	23
NOR Flash Memory	25
Program	27
Erase	28
Negative Gate Erase	29
Overerase	29
NOR Flash Memory Specifications	30

Flash EEPROM	32
Erase	33
Programming	34
Flash EEPROM Memory Specifications.....	35
NAND Flash Memory	36
Program and Erase.....	36
NAND Flash Memory Specifications	36
What's All This <i>Cycling</i> Stuff, Anyway?	38
Failure Analysis.....	40
Oxide Breakdown.....	40
Electron Trapup.....	41
Mean Time Before Failure	41
Extended Cycling-The Vendor's Options.....	42
Extended Cycling-What Can You Do?	43
Summary.....	44
Chapter Four: Packaging Options and Update Alternatives.....	45
Packaging Options.....	46
DIP (Dual In-Line Package)	46
LCC (Leaded/Leadless Chip Carrier).....	49
SOJ (Small-Outline J-Lead)	52
SOP (Small Outline Package)	54
TSOP (Thin Small Outline Package)	54
SIMM (Single In-Line Leadless Memory Module)	59
PCMCIA Flash Memory Cards	62
Flash Drives.....	66
Update Options.....	68
Off-Board PROM Programming	68
On-Board Update.....	69
In-System Write.....	71
Summary.....	72
Chapter Five: Hardware Interfacing to Flash Memory Components	73
Hardware Interfacing Fundamentals	73
Chip Enable	75
Addresses.....	75
Data In/Out	76
Output Enable.....	76
Write Enable.....	77

$\overline{\text{WE}}$ -Less Flash Memories	78
The V_{PP} Program/Erase Voltage	79
Switching V_{PP}	80
V_{PP} Feedback.....	81
Advanced Hardware Interfacing	82
The $\overline{\text{PWD}}$ Input	82
$\text{RY}/\overline{\text{BY}}$ Output	84
Interpreting Datasheet AC Parameters.....	85
General Observations.....	90
Naming Conventions.....	91
Capacitive Loading and Effects	92
AC Read Characteristics	93
Read Specification Clarifications	94
AC Write Characteristics	95
Write Specification Clarifications	96
Performance Enhancements	98
Caching	98
Shadowing.....	98
Hardware Interleaving.....	99
Summary	104
Chapter Six: Power Requirements and Design Techniques	105
The V_{CC} Operating Voltage	106
Read Mode (I_{CCR})	108
Standby Mode (I_{CCS})	109
Deep Powerdown Mode (I_{CCD}).....	110
Program Mode ($I_{\text{CCW}}/I_{\text{CCP}}$).....	111
Erase Mode (I_{CCE})	112
The V_{PP} Program/Erase Voltage	113
Read/Standby Mode (I_{PPR} and I_{PPS})	114
Deep Powerdown Mode (I_{PPD})	114
Program Mode ($I_{\text{PPW}}/I_{\text{PPP}}$).....	115
Erase Mode (I_{PPE})	115
V_{PP} Generation Techniques.....	117
Directly from a 12V Regulated Supply.....	117
Converting from 12V Unregulated	118
Converting from a Lower Voltage	118
Converting from a Higher Voltage	120

General Characteristics of Voltage Converters	121
Totally Modular Solutions	122
Bypass and Decoupling Capacitive Filtering	122
Decoupling Capacitors- V_{CC}	123
Bypass Capacitors- V_{CC}	124
Decoupling Capacitors- V_{PP}	124
Mixed-Voltage System Design.....	125
3.3 Volt to 5 Volt Interfaces.....	125
5V to 3.3V Interfaces	127
Bidirectional Bus Interface.....	130
Power Management Techniques.....	130
Summary	132
Chapter Seven: Software Interfacing to Flash Memory	133
Why Is Flash Memory Controlled By System Software?	134
EPROM Programming Algorithm.....	134
Flash Memory Programming.....	136
The NOR Bulk-Erase Flash Memory Algorithms	139
The Program Algorithm.....	140
The Chip Erase Algorithm.....	143
Summary of First-Generation Programming/Erase Characteristics	148
The NOR Fully-Automated Flash Memory Algorithms	149
Intel Automated Program Algorithm.....	151
Intel Automated Block Erase Algorithm.....	156
Intel Automated Erase Suspend/Resume Algorithm..	160
Alternative Automated Algorithms	162
General Automated Algorithm Techniques-Multiple Block Erase.....	168
General Automated Algorithm Techniques-Page Programming	168
General Automated Algorithm Techniques-Aborting Internal Automation.....	168
General Automated Algorithm Techniques-The RY/ \overline{BY} Output.....	169
Software Polling or Hardware Interrupt: Which Should You Use?	169
Update Routines	170

Flexible Design Techniques.....	172
System Boot Code Contents	173
Software Interface to Flash Cards, SIMMs and Multi- Component Arrays	174
Parallel Program of Non-Automated Flash Memories	176
Parallel Erase of Non-Automated Flash Memories	179
Parallel Program/Erase of Automated Flash Memories	183
Summary	184
Chapter Eight: Hardware Interfacing Considerations for Flash Cards	187
A Flash Memory Array Within a Card	187
PCMCIA Flash Memory Cards.....	188
PCMCIA 1.0	188
PCMCIA 2.0	189
PCMCIA Signal Definitions	193
Host System Implementations.....	211
Implementing PCMCIA 2.0 Hardware	220
Proprietary or Commercial Interface Controllers	220
Supporting Hardware for PCMCIA-Interface Controllers.....	220
Accessing Flash Memory Cards with PCMCIA- Interface Controllers	222
More On Buffering	222
Summary	225
Chapter Nine: Flash Memory File Systems	227
Introduction	227
Flash Memory Solid-State Drive Form Factors	227
Flash Memory Solid-State Drives Require Special Drivers.....	228
Disk-Drive Basics	229
DOS Data Structures.....	231
Device Drivers	233
Flash File System Designs	238
Measuring Drive Usage	239
The Disk-Drive Emulators	239
Flash Optimized File Systems.....	240

The Disk-Drive Emulators.....	241
Primitive Flash File Systems	242
Full-Featured Disk-Drive Emulators	247
Flash Optimized FSSD's	252
Accessing the Flash-Optimized FSSD	253
Microsoft's Flash File System Design Criteria.....	253
Functional Description	256
Flash File System Evaluation	265
Performance - File Transfer Rate	265
Performance - Clean-Up Efficiency	267
Performance - Hot and Cold File Management.....	268
Reliability - Cycle Leveling	268
Reliability - Failure Recovery Modes	269
System Level Issues - File System Overhead.....	270
System Level Issues - Ease of Use	270
Summary	271
Chapter Ten: PCMCIA Software	273
Introduction	273
The Areas of Software Compatibility	274
The PCMCIA-ExCA Relationship	277
Flash File System Models	279
The Original Flash File System Model	279
What's Really Necessary?.....	282
Socket Services.....	282
Defining the Adapter Hardware	283
Accessing Socket Services	284
Installing Socket Services.....	286
The Socket Services Functions.....	287
Non-Specific Functions	289
Adapter Functions	292
Window Functions	304
Fields In The I/O Window Characteristics Table.....	317
Window Size	318
Detecting Card Insertion.....	347
Error Detection and Correction Functions	347
Socket Service Design Considerations and Benefits.....	348
The Card Information Structure	349

Accessing the Card Information Structure.....	350
The Device Information Tuple.....	356
Card Services.....	363
What is Card Services?	364
Do You Need Card Services?.....	366
Flash Card Memory Technology Drivers	366
Why Support New Cards?.....	367
Flash Card Driver Functions	367
Interfacing to the Flash Card Driver	368
Installing the Flash Card Drivers	368
Summary	371
Appendix A: Flash Memory Component Vendors	373
Appendix B: Flash Memory Card/Drive Vendors	375
Appendix C: Flash Memory Component and Card Programmers	379
Appendix D: Component and Card Socket and Adapter Vendors.....	383
Appendix E: 12V Converters	387
Appendix F: Flash Memory Card Readers and Writers.....	391
Appendix G: Flash File Systems.....	395
Appendix H: PCMCIA and Software Vendors	397
Appendix I: PCMCIA Compliance Testing Facilities	399
Appendix J: PCMCIA Card Types.....	401
Appendix K: PCMCIA Controller Register Functions and Vendors...	403
Appendix L: INT 21H Standard Disk-Related Functions.....	409
Appendix M: Sample Flash File System Benchmarking Code.....	411

Figures

1.1: The Exploding Flash Memory Market	1
1.2: Flash Memory Cell Simplicity Enables Cost-Effective Manufacturing.....	2
1.3: Average Selling Price for 1 Mbyte of Flash Memory Storage	3
1.4: Flash Memory Satisfies Many Ideal Memory Attributes	7
2.1: BIOS Glues Common Software to Unique Hardware.....	17
2.2: Energy Consumed During Various Activities.....	20
2.3: Elan Flash Memory Card Reader/Writer.....	21
3.1: Dataquest 1992 Flash Memory Market Share (by company).....	24
3.2: ETOX™ Flash Memory Cell Similarities Leverage EPROM Learning Curve	25
3.3: ETOX™ Flash Memory Cell Being Read.....	26
3.4: NOR Flash Memory Array Interconnect.....	26
3.5: ETOX™ Flash Memory Cell Being Programmed	27
3.6: EPROM Cell Being UV Erased	28
3.7: ETOX™ Flash Memory Cell Being Erased	28
3.8: Negative Gate Erase	30
3.9: Iterative Basic Flash Memory Erase Algorithm.....	31
3.10: EEPROM-Based Flash Memory Cell.....	33
3.11: EEPROM-Based Flash Memory Cell Being Erased	34
3.12: EEPROM-Based Flash Memory Cell Being Programmed.....	35
3.13: NAND Flash Memory Cell Being Read.....	36
3.14: NAND Flash Memory Array Interconnect.....	37
3.15: NAND Flash Memory Cell Being Programmed	37
3.16: NAND Flash Memory Cell Being Erased	38
4.1: DIP (Dual In-Line) Package Dimensions	47
4.2: DIP / TSOP Package Comparison (Actual Size).....	48
4.3: LCC (Leaded Chip Carrier) Package Dimensions	50
4.4: Trace Layout Comparison: PSOP vs. PLCC.....	51
4.5: Small Outline J-Lead (SOJ) Package Dimensions	53
4.6: Small Outline Package (SOP) Dimensions	55
4.7: TSOP (Thin Small Outline Package) Dimensions	56
4.8: Standard and Reverse TSOP Packages.....	57
4.9: TSOP Serpentine Package Layout.....	58
4.10: SIMM Package Dimensions	60

4.11: SCM Microsystems Flash Memory SIMM Pinout	61
4.12: PCMCIA / JEIDA Type 1 PC Card Package Dimensions	64
4.13: PCMCIA / JEIDA Type 2 PC Card Package Dimensions	64
4.14: Mass Storage Architecture	66
4.15: Flash Drive Architecture	66
4.16: Design Considerations During On-Board Update	69
4.17: Key Elements of In-System Update	70
5.1: Processor/Flash Memory Interface (separate address and data buses, distinct read and write, one flash memory)	74
5.2: Processor / Flash Memory Interface (multiplexed address/data lines, multiplexed read/write, two x8 flash memories)	74
5.3: V_{PP} Switch Circuit	80
5.4: Maxim MAX705, Used for V_{CC} and V_{PP} Monitoring	82
5.5: Intel 28F001BX Boot Block Flash Memory Map	83
5.6: Wired-OR RY/ \overline{BY} Implementation	85
5.7: Flash Memory Read Access Time Partitioning	86
5.8: AC Input/Output Reference Waveform	86
5.9: AC Testing Load Circuit	87
5.10: High Speed Input / Output Reference Waveform	87
5.11: High Speed AC Testing Load Circuit	87
5.12: AC Waveforms for Read Operations	88
5.13: AC Waveforms for Write Operation	89
5.14: Example Ordering Information Table	90
5.15: Hardware Interleaving - Utilizes Common \overline{CE} , Unique \overline{OE} and \overline{WE}	100
5.16: Hardware Interleaving - State Transition Diagram	103
6.1: V_{CC} Current (Typical) - Read Mode	109
6.2: V_{CC} Current (Typical) - Program Mode	111
6.3: V_{CC} Current (Typical) - Erase Mode	112
6.4: V_{PP} Current (Typical) - Program Mode	114
6.5: V_{PP} Current (Typical) - Erase Mode	115
6.6: V_{PP} Current (Typical) - Beginning of an Erase Pulse	116
6.7: Linear Technology LT1110 5V to 12V Converter	118
6.8: Motorola MC34063A 5V to 12V Converter	119
6.9: Maxim MAX732 3V to 12V Converter	119
6.10: Maxim MAX667 12V Linear Voltage Regulator	120
6.11: Linear Technology LT1111 Voltage Step Down Switcher	120

6.12: Interfacing a 3.3V Device to a 5V Device (TTL Inputs)	126
6.13: Interfacing a 3.3V Device to a 5V Device (CMOS Inputs)	127
6.14: Interfacing a 5V Device to a 3.3V Device	128
6.15: 5V to 3.3V Direct Interface. Overbiasing the ESD Input Diode	128
6.16: Interfacing a 5V Device to a 3.3V Device - Series Resistor Voltage Drop	129
6.17: Interfacing a 5V Device to a 3.3V Device.-	129
7.1: EPROM Programming Algorithm (Simplified Form).....	135
7.2: Intel First Generation Flash Memory Non-Automated Programming Algorithm.....	137
7.3: Intel First Generation Flash Memory Non-Automated Erase Algorithm.....	144
7.4: Intel Automated Flash Memory Program Algorithm	152
7.5: Intel Automated Flash Memory Status Register	155
7.6: Intel Automated Flash Memory Block Erase Algorithm.....	157
7.7: Intel Automated Erase Suspend / Resume Algorithm	161
7.8: AMD 5V-Only Automated Program Algorithm.....	165
7.9: AMD 5V-Only Automated Erase Algorithm	166
7.10: AMD 5V-Only Automated Data Polling and Toggle Bit Algorithm.....	167
7.11: Parallel Programming of Non-Automated Flash Memories	177
7.12: Parallel Erase of Non-Automated Flash Memories.....	180
7.13: Parallel Program / Erase of Automated Flash Memories	184
8.1: PCMCIA 1.0 Flash Memory Card.....	190
8.2: Intel Series 2 Flash Memory Card.....	191
8.3: PCMCIA Electrical Interface Categories	193
8.4: PCMCIA Read Timing Waveform.....	195
8.5: Aliasing Caused by Inadequate Address Line Decoding	195
8.6: Internal Component Arrangement Dictated by Flash Memory Architecture	197
8.7: Byte-Wide Access Mode Circuitry for 8-Bit Systems	198
8.8: RDY/ $\overline{\text{BSY}}$ Background Sequence	201
8.9: Use of RDY/ $\overline{\text{BSY}}$ in Multiple Device Operations	202
8.10: Standard PCMCIA RDY/ $\overline{\text{BSY}}$ Waveform	203
8.11: High-Performance RDY/ $\overline{\text{BSY}}$ Waveform for Multiple Device Operations.....	204

8.12: PCMCIA Pin Lengths Allow Proper Sequencing of Card Signals	205
8.13: Example Card Detection Circuitry	206
8.14: PCMCIA Controller Chip Controls Voltage Switching	209
8.15: Mapping Memory Through an I/O Port.....	212
8.16: The Data Bus Generates the Flash Memory Addresses	213
8.17: Counters Enhance I/O-Mapped Read Access	213
8.18: Linearly-Mapped Memory Addressing.....	215
8.19: DOS Memory Map.....	216
8.20: Memory Paging Circuitry	217
8.21: Implementing a PCMCIA 1.0 Interface in an Embedded Application	219
8.22: The Intel 82365SL PCMCIA Interface Controller Requires a Minimal Amount of Support Circuitry.....	221
9.1: Flash Memory Manager and Operating System Interface	230
9.2: Disk Drive Tracks and Sectors.....	230
9.3: File Directory and FAT Modification.....	232
9.4: New Device Drivers Supersede Default Drivers	234
9.5: Using the Disk Service Interrupts to Access Disk Sectors	236
9.6: Accessing Devices Using File Handles, Not at the Sector Level	238
9.7: Flash Memory Solid-State Drive System Layers.....	240
9.8: Using an Interrupt Filter.....	242
9.9: Creating a Disk Image in Flash Memory	243
9.10: A Flash Memory Array Pre-Formatted with a Blank FAT and Root Directory	245
9.11: Sector-Level Modification Requires Considerable Overhead ...	246
9.12: One-to-One Correspondence Between FAT Entries and Sectors	248
9.13: Three-Step Cleanup Operation: Copy, Erase, and Block Renumbering	250
9.14: Defragmentation Utility Concatenates.....	252
9.15: Flash Memory Solid-State Drive Accessing Methods.....	254
9.16: Microsoft's First FFS Functioned Like a WORM Drive	255
9.17: Files are Always Written to the Next Available Free Space	257
9.18: Linked List Pointers Locate Nest File in the Chain	258
9.19: Each Subdirectory has Its Own Linked List	259
9.20: MS-Flash Performs a Three-Step Clean-up Operation.....	260

9.21: Worst-Case Foreground.....	263
9.22: File Clean-Up	264
10.1: Glue Logic Holds Together the Major System Pieces	274
10.2: Many Types of PCMCIA-Compatible Cards can Operate in the Same Socket.....	276
10.3: PCMCIA Provides a General, Three-Dimensional Specification Covering Processors, System Architectures, and Operating Systems	278
10.4: ExCA Provides a Specific Implementation of PCMCIA	278
10.5: The Non-Modular Flash File System Lacked Flexibility.....	280
10.6: Complete and Flexible Implementation of a Flash File System Consists of Five Modules	281
10.7: Use an Index and Data Register Combination to Access the PCIC's Internal Registers	284
10.8: The Functions of Socket Services Act Like a Black-Box Where Parameters Go In and Out.....	285
10.9: An Application Uses Interrupt 1AH to Access Socket Services or the PC's Real-Time Clock.....	286
10.10: Multiple Socket Services can be Chained Together and Accessed Through the Common Entry Point of INT 1AH.....	287
10.11: Reading a Signature from the Adapter Board to Identify Its Presence	290
10.12: Socket Services Isolates the Differences between a Removable Memory Card and Permanently Resident Flash Array	291
10.13: Five Memory-Mapped Windows for Flash Memory Card Access in an ExCA System.....	293
10.14: InquireAdapter Returns Information Describing the Adapter's Capabilities, such as the Power Characteristics	296
10.15: The Global Control Register Powers Down the PCIC	299
10.16: Distinguishing Between an Adapter Interrupt and a Socket Interrupt	300
10.17: Mask Status Change Interrupts at the Socket Level, Enabling Them at the Adapter Level	302
10.18: Writing a One to Bits 0-3 Enables the Corresponding Status Change to Generate an Interrupt.....	303
10.19: Determine the Interface Type from the Identification and Revision Register in PCIC-Compatible Controllers.....	306

10.20: As the Memory Window Characteristics Table Indicates, the Base Address and Size may be Programmable	308
10.21: Contrasting Windows Divided into Pages and Multiple Windows.....	312
10.22: Minimum and Maximum Memory Window Address.....	313
10.23: Example Showing Potential Base Address for a 4 Kbyte Window that Must Reside on a Multiple of the Window's Size.....	315
10.24: Use this Register to Enable and Disable Memory and I/O Windows.....	320
10.25: These PCIC Registers Control the Access Speed and Determine the Stop Address of the Corresponding Memory Window	322
10.26: These PCIC Registers Set Up the Base Address of the System Memory Window	324
10.27: These PCIC Registers Set Up the Flash Memory Card's Offset, Enables Write Protection, and Selects the Memory Plane.....	327
10.28: Translating System Addresses to Access Various Regions within the Flash Memory Card.....	329
10.29: This PCIC Register, Power Control and RESETDRV, Controls a Socket's Voltage Levels	335
10.30: The Card Status Change Register Reports on the Source of the Status Change.....	336
10.31: Use an I/O Port to Control the Socket's Indicators	337
10.32: Read the Interface Status Register with the GetStatus Function to Determine the Presence of a Card	339
10.33: Writing to this PCIC Register Activates the PC Card's Reset State.....	341
10.34: Flash Memory Card Partitioning Examples.....	351
10.35: Select between a Flash Memory Card's Common and Attribute Memory Planes using the REG Signal.....	351
10.36: A Tuple is the Basic Data Structure in the CIS	353
10.37: Card Services Interfaces between Clients (Applications, Device Drivers) and PC Cards, Sockets, and System Resources	365
10.38: Installing a New Flash Card Driver	370

Tables

1.1: Flash Memory Evolution and Innovation Broaden the Application Base.....	3
1.2: Flash Memory Versatility Answers the Needs of Many Applications.....	6
3.1: NOR Flash Memory Characteristics	32
3.2: EEPROM Flash Memory Characteristics.....	35
3.3: NAND Flash Memory Characteristics	38
4.1: The Key Differences between a Flash Drive and a PCMCIA Flash Memory Card.....	66
5.1: Flash Memory Bus Interface	74
5.2: \overline{WE} -Less Flash Memory Bus Interface.....	79
5.3: JEDEC Signal/State Naming Conventions.....	91
5.4: AC Characteristics, Read Operations.....	93
5.5: AC Characteristics, Write Operations.....	97
5.6: Input/Output Capacitance.....	97
6.1: DC Characteristics.....	107
7.1: Intel Bulk-Erase Flash Memory Command Definitions.....	139
7.2: Intel Block-Erase Flash Memory Command Definitions.....	150
7.3: AMD 5V-Only Automated Algorithm Command Definitions.....	163
8.1: Signal Definition of the PCMCIA Interface.....	192
8.2: Common Memory Accesses	197
8.3: System Power Requirements	208
8.4: Voltage Sense Pin Configurations.....	211
8.5: PC Card Interface Conditions During Insertion and Removal.....	223
9.1: FAT Values for 12 and 16 Bit Entries.....	231
10.1: PCMCIA and ExCA Relationship.....	279
10.2: Socket Services Functions.....	288
10.3: Adapter Characteristics and Power Management	295
10.4: Example Adapter Characteristics and Power Management	297
10.5: Card Status Change Interrupt Steering.....	301
10.6: Interface Identification for PCIC-Compatible Controllers.....	305
10.7: Memory Window Characteristics.....	307
10.8: Example Memory Window Characteristics	316
10.9: I/O Window Characteristics	317

10.10: Controlling V_{pp} Enable Signals with the PCIC's Power Control Register.....	335
10.11: Tuple Format.....	352
10.12: Minimum Tuple Requirements	355
10.13: Sample Device Information Tuple	356
10.14: Sample Device ID Byte.....	357
10.15: Sample Device Size Byte.....	358
10.16: Sample Device Geometry Tuple	360
10.17: Sample JEDEC Identifier Table.....	361
10.18: Size of Field Byte.....	361
10.19: Sample Configuration Table	362
10.20: Sample End-of-List Tuple.....	363
10.21: System Memory Architectures.....	369

Chapter Three: Flash Memory Technologies

From a very high-level perspective, Chapter 1 answered the question, “What is Flash Memory?” As a review, flash memory has the following primary characteristics:

- Nonvolatility (retains data stored to it when powered off), and
- In-System Updateability (stored data can be erased and replaced under system processor control)

As you can see, this is a pretty broad definition! Various semiconductor vendors have chosen unique and quite dissimilar silicon technology approaches to answer the above application requirements. Some flash memory approaches are *evolutionary*, based on existing memory types that are already nonvolatile and updateable. Other technologies choose a more *revolutionary* path.

This chapter will discuss in detail three flash memory technologies: NOR, EEPROM, and NAND. All three approaches meet the basic criteria for flash memory (nonvolatility and updateability). Where they differ, however, is in their secondary characteristics, some of which are listed below³:

- Read Performance
- Program/Erase Performance

³Chapter 2 discussed specific flash memory applications and indicated the highest priority features in each case.

- Number of Program/Erase Cycles Through Device Lifetime
- Power Supply Voltage Requirements
- Current Draw in Device Operating Modes
- Erase Block Size

When evaluating flash memory alternatives, do not overlook the manufacturing process complexity, and the size of the flash memory cell and periphery logic. Both factors translate into component cost, and ultimately to the price you pay for the component or flash-based subsystem from the manufacturer or distributor. Keep this in mind as you read about the “latest and greatest” flash memory technology unveilings. Creating something in the laboratory is one thing; consistently recreating it in high volume and with low cost in a manufacturing facility is entirely another matter!

As a framework for the following discussion, Figure 3.1 shows the 1992 relative market share for several flash memory semiconductor vendors. The anticipated demand for flash memory in the very near future is evident, and many semiconductor companies are gearing up to supply this market.

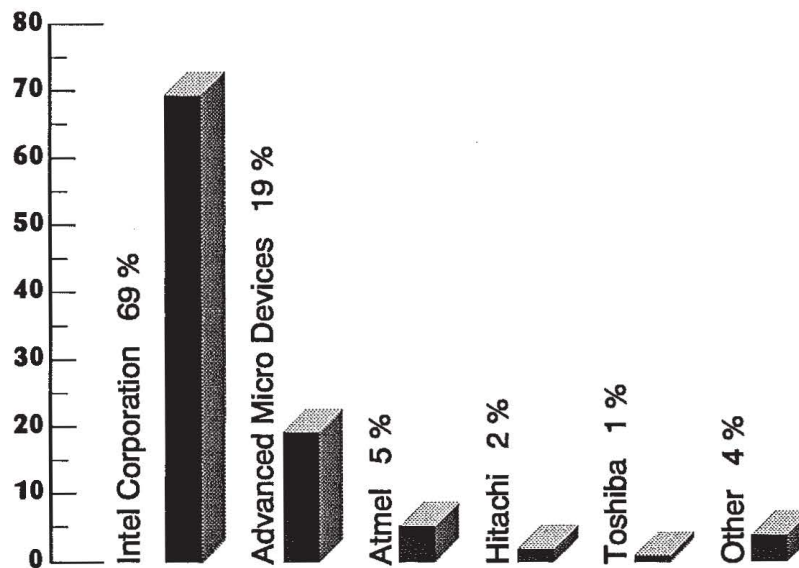

Figure 3.1: Dataquest 1992 Flash Memory Market Share (by company)

NOR FLASH MEMORY

(Examples: Intel Corporation, Advanced Micro Devices, Hitachi, Mitsubishi, NEC, SGS-Thompson, Fujitsu, Toshiba Corporation)

NOR flash memory was introduced by Intel Corporation in 1988, using the company's ETOX™ (EPROM Thin Oxide) process technology. Since that time, products based on similar technologies have been announced by several other semiconductor vendors. Figure 3.2 compares the ETOX flash memory cell with an EPROM (Erasable Programmable Read-Only Memory) cell. The similarity in this revolutionary approach is clear; NOR flash memory derives from an EPROM base. The key difference is in the silicon oxide thickness between the floating gate and substrate. This thinner oxide is the key to NOR flash memory operation; we'll see why in a moment.

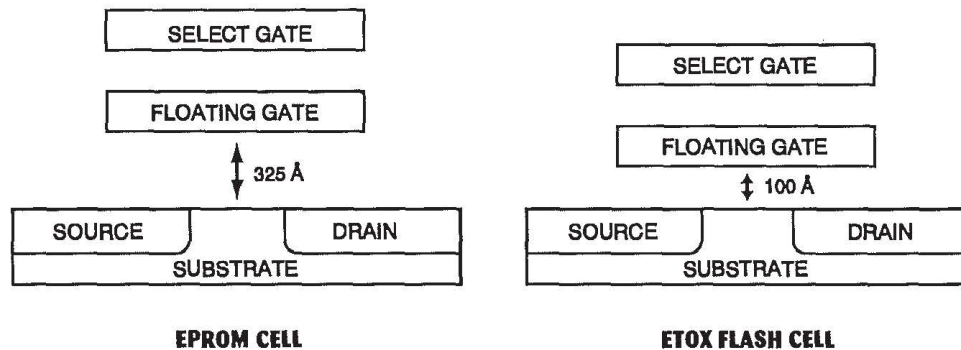

Figure 3.2: ETOX™ Flash Memory Cell Similarities Leverage EPROM Learning Curve

When shipped from the vendor, the default state of all cells in a NOR flash memory is one, corresponding to an *erased* condition. Figure 3.3 shows the voltages present on the cell when read. When erased, the floating gate of the flash memory cell does not block the cell from being turned on by the applied voltages on the select gate and drain. The resulting current is sensed at the transistor source, and translated to a one at the memory output pin.

Figure 3.4 shows a portion of a flash memory array and the interconnection of the various transistors. Device addresses enable specific wordlines and bitlines; in combination they select one transistor

within the array per device output. This organization also explains the NOR name for this architecture; any "on" transistor (i.e., a selected, erased cell) in the chain results in the earlier-described current draw, sensed at the end of the chain and converted to an output one.

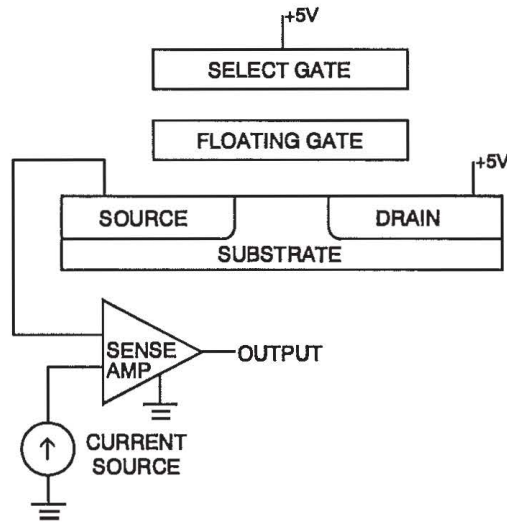

Figure 3.3: ETOX™ Flash Memory Cell Being Read

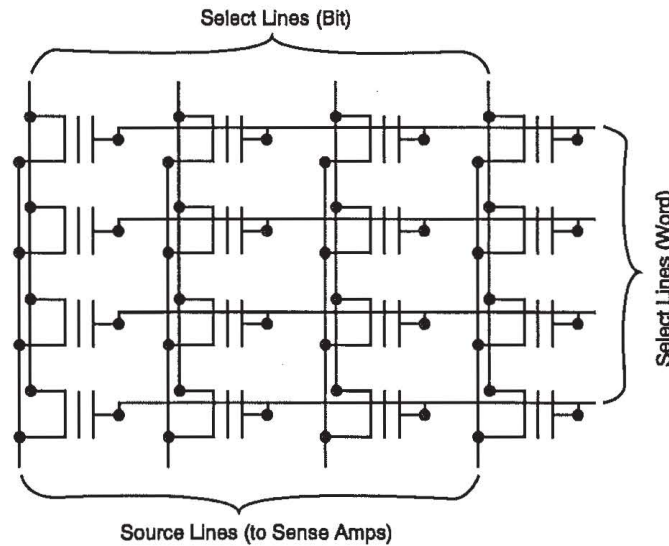

Figure 3.4: NOR Flash Memory Array Interconnect

Program

Changing a flash memory cell (or bit) to a zero is called *programming*. NOR flash memory employs the same programming mechanism as EPROM, namely hot electron injection. Figure 3.5 shows an ETOX flash memory cell being programmed. As electrons travel from the source to the drain through the substrate, the electric field generated by high voltage on the select gate causes some of the highest energy electrons to jump the gap and collect on the floating gate. What's the result? Referring back to Figure 3.3, we see that the electrons now present on the floating gate counteract the voltage on the select gate and prevent the flash memory cell from turning on. No current flows from drain to source, resulting in a zero on the memory output pin.

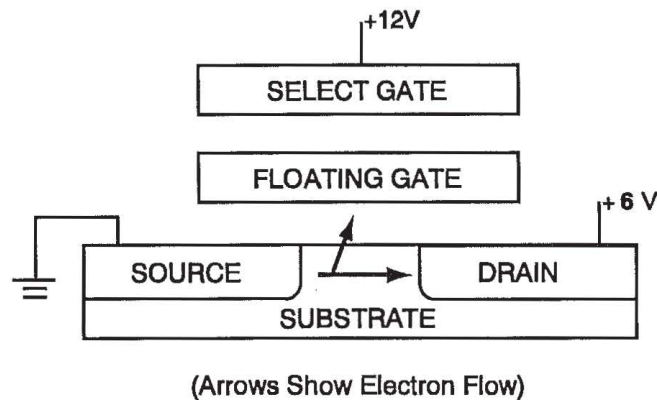

Figure 3.5: ETOX™ Flash Memory Cell Being Programmed

NOR flash memory cells can be selectively programmed to zero. In other words, programming is a *bit-level* operation. On a byte-wide flash memory device, for example, one bit of a selected byte can be programmed to zero, leaving the other seven bits at one. Later programming of the same byte can change other bits to zero in the same way. However, one key point to note about NOR flash memory (and about other flash memory approaches, too) is that *programming only changes ones to zeros*. Here lies a fundamental difference between flash memory and other rewriteable memory technologies like RAM. To change programmed zeros back into ones, we must use a different mechanism, called erase.

Erase

EPROMs are erased by ultraviolet light. As shown in Figure 3.6, the extra energy generated by UV light enables electrons on the floating gate (put there by programming) to overcome the inherent semiconductor energy potential and return to the substrate. After erasure, an EPROM cell once again reads as a one. To allow UV light to shine on all EPROM cells on a device array, the package must include a built-in glass window. As manufacturing lithographies become smaller and smaller, it becomes harder and harder to ensure that UV light can reach all array cells. The window requirement also puts limits on how small the device package can become.

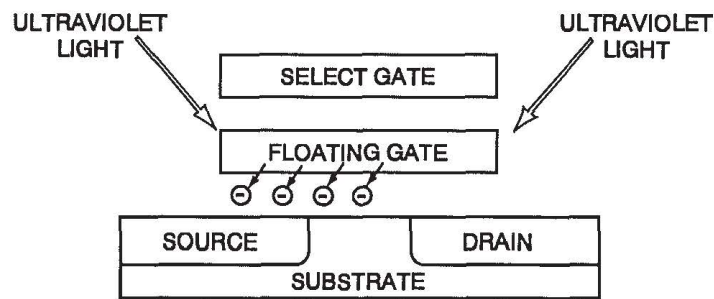

Figure 3.6: EPROM Cell Being UV Erased

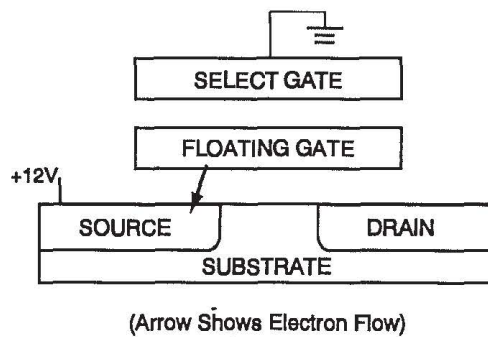

Figure 3.7: ETOX™ Flash Memory Cell Being Erased

Rather than using UV light, NOR flash memory cell erasure is accomplished electrically using a process called Fowler-Nordheim tunneling. Figure 3.7 shows the voltages on the flash memory cell during

erase. The generated electric field pulls electrons from the floating gate. First generation *bulk-erasure* NOR flash memories erase all cells in the array at the same time. Second generation NOR devices erase in smaller blocks. Following the same train of thought, this is called *block erase*. Erase block size varies from flash memory vendor to vendor, and from device to device, based on the targeted applications.

Compared to EPROM, the array transistors in a flash memory need not be accessible to UV light exposure. This allows flash memory designers to run layers of interconnection over the cell versus around it, simplifying the design and minimizing the device die size. As an analogy, think of a multi-layer versus a single-layer printed circuit board. Also, flash memory does not require the window of an EPROM, allowing very small footprint (and less expensive) packaging⁴.

Negative Gate Erase

Negative gate erase is similar but not identical to the conventional cell erase approach described earlier. Figure 3.8 shows the voltages on the flash memory cell during negative gate erase. Comparing this diagram with Figure 3.7, we see that although the voltages on the cells are different, the resultant voltage potential difference (and electric field) between gate and source is similar. Negative gate erase also uses Fowler-Nordheim tunneling to remove electrons from the floating gate.

Overerase

Removing too many electrons from the floating gate of a flash memory cell may theoretically result in an *overerased* condition (i.e., removing more electrons than were put there by a previous cell program). The effects of overerase are destructive to the flash memory device. Once overerased, a flash memory cell cannot be programmed again (within practical limits). Reads of this cell, as well as adjacent cells in the array, produce erratic and invalid results. Referring back to Figure 3.4, we see that an overerased cell, being “always on” even if not selected, overrides any valid data on the array transistor “chain”. *Oops!*

⁴We'll see this again in Chapter 4.

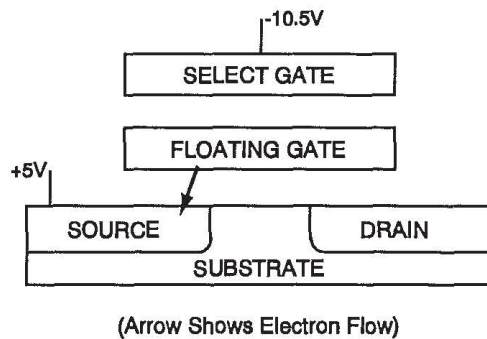

Figure 3.8: Negative Gate Erase

Fortunately, flash memory erase algorithms include built-in procedures to eliminate the potential for overerase⁵. First, cell erase (like cell programming) uses an iterative algorithm. Shown in simplified form in Figure 3.9, the built-in feedback loop ensures that the algorithm terminates and does not allow further removal of floating gate electrons once sufficient cell erase has been detected. Secondly, since all flash memory cells in a given device (or block within an device) are erased in parallel (and at approximately the same rate), preprogramming ensures that all cells are at a common initial programmed state. Without preprogramming, already-erased cells in the device or in a given erase block would be overerased while programmed cells were being erased.

Newer NOR flash memories control the erase algorithm internally, and automate both the erase preprogramming and iterative erase/verify steps. This dramatically simplifies system software algorithms and eliminates any potential for error. For more information, reference Chapter 7.

NOR Flash Memory Specifications

Table 3.1 provides a summary of NOR flash memory device characteristics, derived from data on Intel Corporation's latest-generation products. These specifications are indicative of the relative levels of performance possible today using NOR flash memory. However, exact

⁵If they are implemented *exactly* as published; a 'word to the wise' for system software programmers!

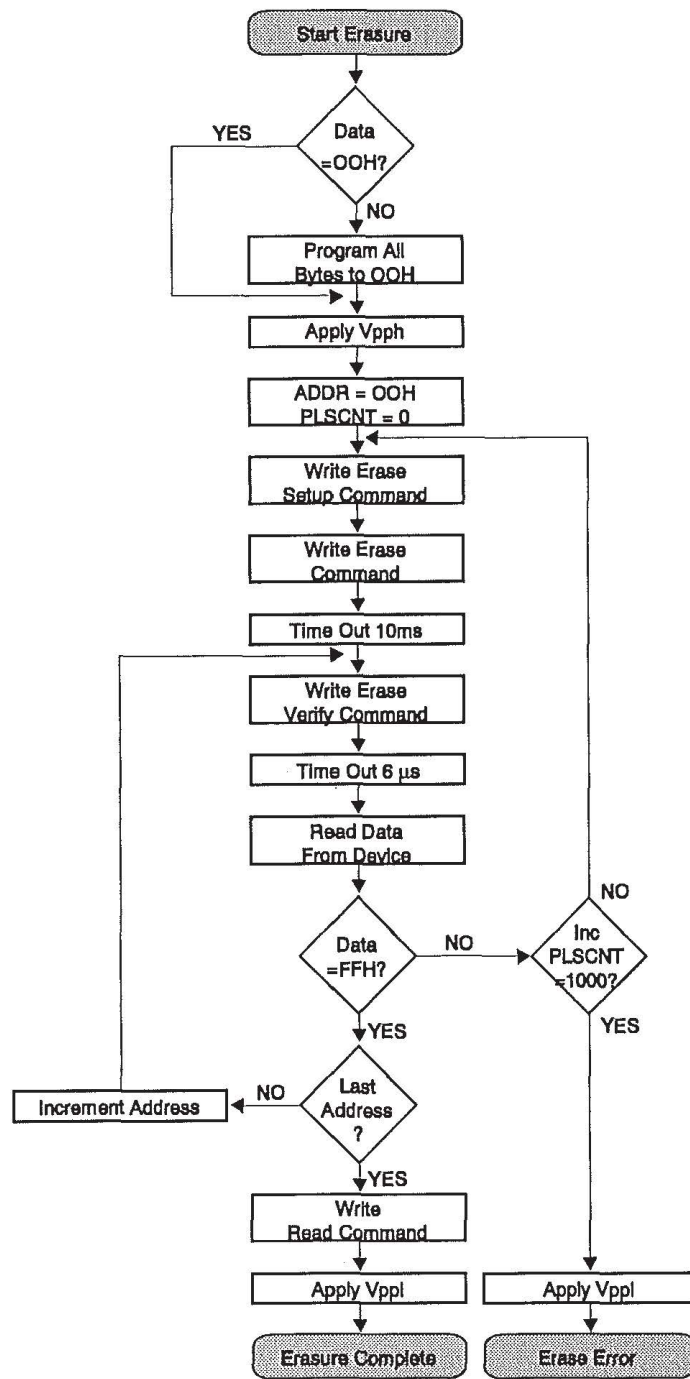

Figure 3.9: Iterative Basic Flash Memory Erase Algorithm

values will vary from device to device, from manufacturing process to manufacturing process, and from vendor to vendor⁶.

Density	8 Mbit
Access Time	60 ns
Data Program Time	6 μ s (min) 9 μ s (typ)
Block Erase Time (64 kbyte block)	0.3 sec (min) 1.6 sec (typ)

Table 3.1: NOR Flash Memory Characteristics

Note the relatively slow erase time compared to read and program. Cell erase time is a primary function of two parameters; oxide thickness between floating gate and substrate, and internal erase voltage (it is also affected by device temperature, and by the number of times the cell has been erased previously, or *cycled*). The cell erase time of the ETOX processes is a direct result of the relatively low 12V and low current used to pull electrons from the floating gate. However, a low erase voltage also translates to excellent cell reliability and extended cycling performance. Later chapters will give examples of flash memory applications where cell erase time is (and is not) a concern, as well as discussing hardware and software techniques to hide the slow erase as a background system task.

FLASH EEPROM

(Examples: Atmel Corporation, Samsung, SunDisk, Catalyst Semiconductor)

The previous discussion showed how NOR flash memory was derived from an existing EPROM base. Similarly, flash EEPROM shares many similarities with standard EEPROMs. Figure 3.10 shows a diagram of a flash EEPROM memory cell.

⁶Consult vendor datasheets, application notes, and engineering reports for information on specific devices. Vendor contact information is in Appendix A.

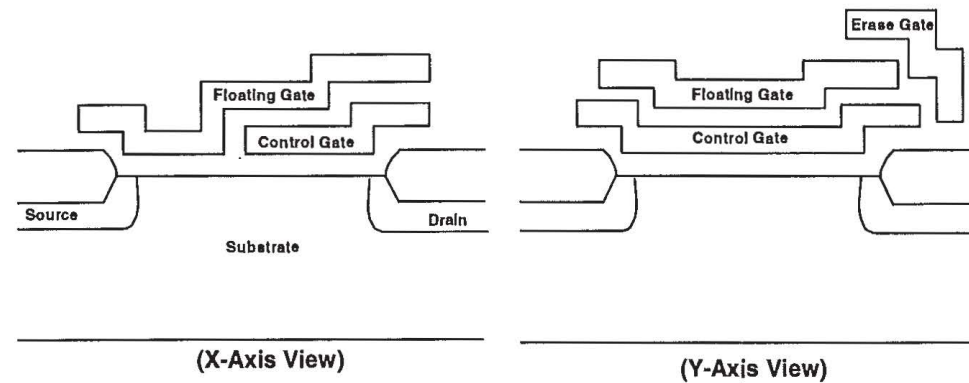

Figure 3.10: EEPROM-Based Flash Memory Cell

A standard EEPROM can be fully altered on a byte-by-byte basis. The byte erase operation is integrated in the write function, i.e., the byte is first erased and then reprogrammed with the desired data. A flash EEPROM, on the other hand, simplifies the silicon design by erasing on a block-level basis. When an EEPROM flash memory block is written, it is first erased and then programmed with data stored in an on-chip buffer.

Erase

Flash EEPROMs erase using Fowler-Nordheim tunneling, as do NOR flash memories. Most, however, use a separate erase gate per cell to collect electrons pulled off the floating gate. Regardless of the specific method, flash EEPROMs use much higher internally-generated voltages because of their greater oxide thickness compared to NOR flash, and to speed erase performance. Remember...erase is a built-in part of rewrite, not a separate operation as in the case of NOR flash. Figure 3.11 shows an EEPROM flash memory cell being erased.

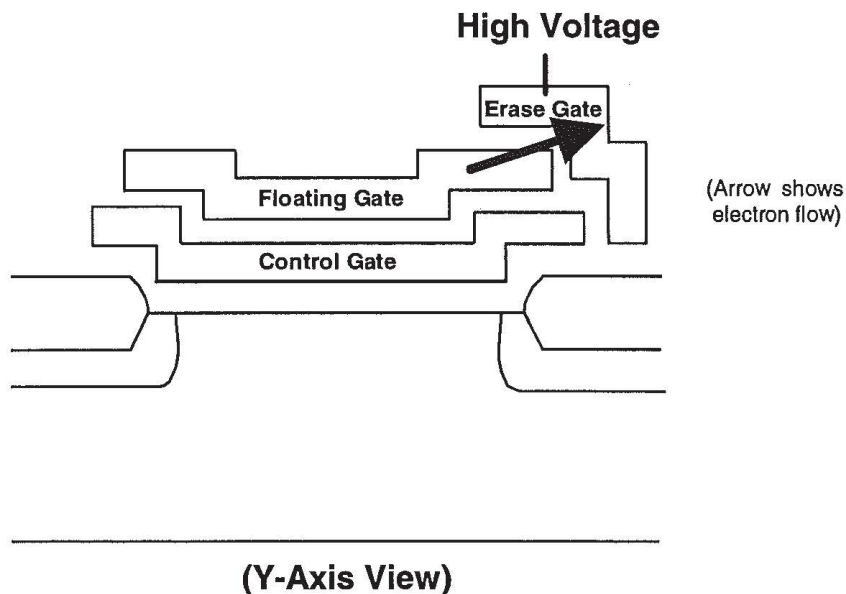

Figure 3.11: EEPROM-Based Flash Memory Cell Being Erased

Programming

Some flash EEPROMs program cells via hot electron injection. Most, however, use a reverse form of Fowler-Nordheim tunneling shown in Figure 3.12. The combination of voltages on the select gate and drain stores electrons on the floating gate, versus removing them, as seen with Fowler-Nordheim erasure. Again, high internal voltages are used for fastest programming performance.

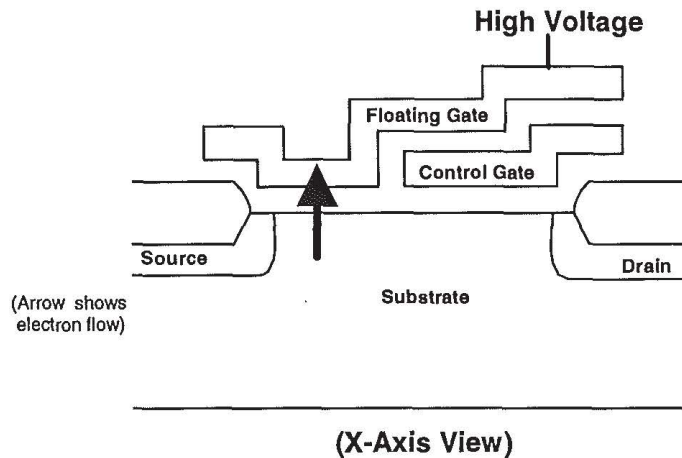

Figure 3.12: EEPROM-Based Flash Memory Cell Being Programmed

Flash EEPROM Memory Specifications

Table 3.2 summarizes flash EEPROM memory characteristics⁷. Since erase is a built-in part of the flash EEPROM program algorithm, flash EEPROMs speed up the erase process time compared to NOR flash memory, primarily via the higher internal voltages on the EEPROM cell. However, over time this may potentially have a negative impact on cell reliability. As the EEPROM cell undergoes repeated erasure, the high electrical field can break down the thin oxide region, causing failure. Some EEPROM vendors have implemented redundant cell and internal error-correction schemes to combat this “Achilles Heel”.

Density	1 Mbit
Access Time	90 ns
Data Program Time	150 μ s

Table 3.2: EEPROM Flash Memory Characteristics

⁷Taken from Atmel Corporation documentation.

NAND FLASH MEMORY

(Example: Toshiba Corporation)

NAND flash memory is a relatively new technology approach pioneered by Toshiba Corporation. As shown in Figure 3.13, the NAND flash memory cell looks very much like a NOR cell! However, the periphery logic designed into NAND is very different, and the internal program and erase approaches most closely resemble flash EEPROM methods.

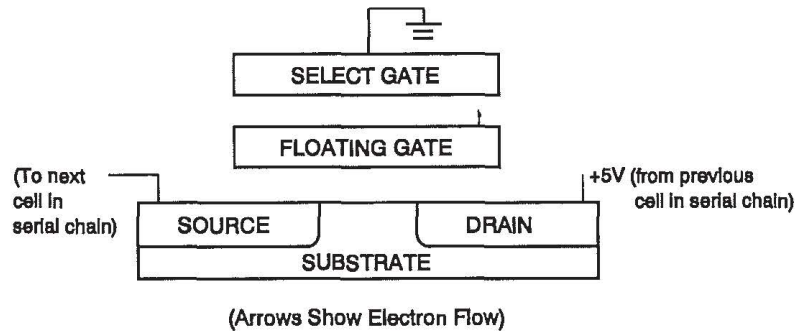

Figure 3.13: NAND Flash Memory Cell Being Read

Like Figure 3.4, Figure 3.14 shows the interconnection of transistors in a NAND array. Data sensing along the chain is serial in nature, and the architecture reflects its name.

Program and Erase

NAND flash memory cells program and erase via reverse and forward Fowler-Nordheim tunneling, respectively. Figures 3.15 and 3.16 show the internal voltages on the cell in each case. Note that unlike flash EEPROM memory tunneling, NAND flash memory applies voltages to the substrate itself, in addition to the select gate.

NAND Flash Memory Specifications

Table 3.3 shows initial specifications for Toshiba's first NAND flash memory-based device. NAND flash memory primarily targets solid state disk drive replacement applications, and the feature set reflects this, with fine-resolution blocking and fast cell erase. However note the slow initial read access time due to serial data read, which may limit broad application usage. Some NAND devices include error detection and correction (EDAC) cells and associated EDAC logic.

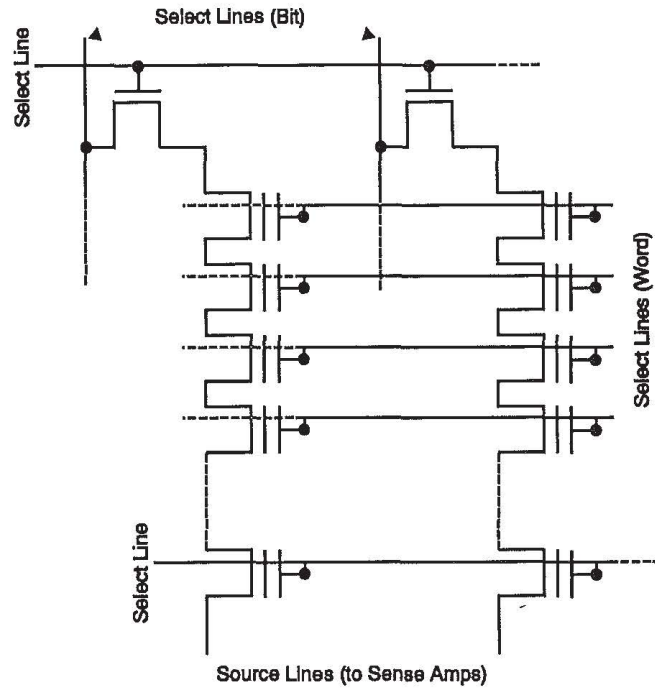

Figure 3.14: NAND Flash Memory Array Interconnect

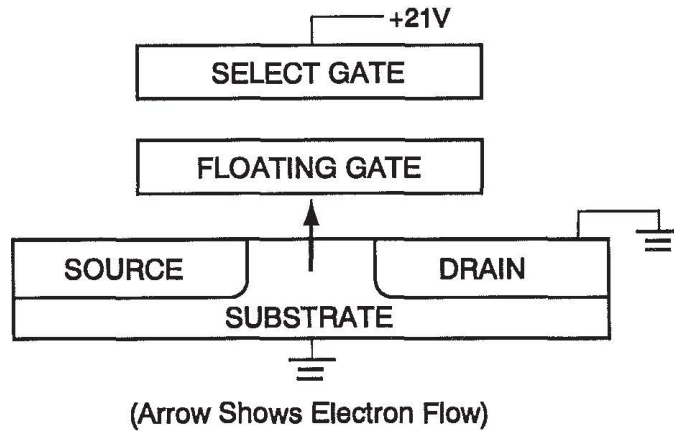

Figure 3.15: NAND Flash Memory Cell Being Programmed

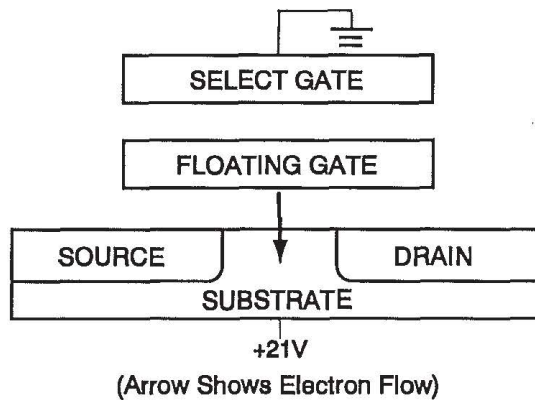

Figure 3.16: NAND Flash Memory Cell Being Erased

Density	4 Mbit
Access Time	15 μ s (initial read) 80 ns (subsequent serial access)
Data Program Time	4 ms (min)
Block Erase Time (4 kbyte block)	6 ms

Table 3.3: NAND Flash Memory Characteristics

WHAT'S ALL THIS *CYCLING* STUFF, ANYWAY?

The subject of cycling is quite possibly the most abused (by companies supplying flash memory) and most misunderstood (by companies buying and using flash memory in their system designs) of any topic you'll find discussed in this book! All sorts of outlandish claims have been made, are being made, and will probably be made in the future, concerning the cycling capabilities of various flash and "flash-like" memory technologies. To confuse you even further, concepts such as MTBF (mean time before failure) are often used in conjunction with cycling specifications. Flash memory vendors often mean well (from a marketing perspective) when they include these numbers, but since an industry standard for the determination or calculation of MTBF doesn't

exist, it is often subject to liberal interpretation and modification. Therefore, MTBF numbers for different flash memory devices and technologies cannot be directly compared without knowing the recipes that were used and the assumptions that were made when the measurements were taken.

We are going to explain cycling in its most fundamental definitions for you, and provide guidelines by which you can calculate your own MTBF numbers for your specific flash memory design and implementation. Our goal here is to cut through all the meaningless marketing hype and provide you with valid, useful information.

What is cycling? A cycling number is:

- a) The minimum number of times a flash memory device (or block within a device) can be erased and programmed in a reasonable amount of time without loss of device functionality, at
- b) A specified failure rate percentage, or FIT (failure-in-time) level.

Flash memory vendors often ignore the latter part of the above definition when publishing their cycling specifications. What good is it to know how many times you can erase an array of flash memory cells if you have no idea of the probability that some of the cells will fail before reaching this cycle count? A parallel can be drawn here with stereo equipment, where inflated claims are sometimes made of an amplifier's output power capability without mentioning how distorted the output signal was when this power was measured. What good is it to hear loud music if you can't understand it? (Of course, with some forms of popular modern music this could be seen as a positive!) Similarly, what good is it to be able to erase flash memory to an extended number of cycles if the media is essentially unusable when it reaches this cycle count? Clearly both parts of the cycling definition are valuable and useful information.

Failure Analysis

Before each flash memory device is shipped to a customer, it undergoes extensive testing to screen out known and detectable failure mechanisms both in the circuitry itself and in the manufacturing process on which the device was made. Even after this testing, it is known and accepted that a certain very small (hopefully!) number of devices will eventually fail, even when operated at all recommended specifications. Some sources of this failure, common to all flash memories as well as other memory technologies, are listed below:

- Package Integrity Failures
- Random Circuitry Failures
- Data Reliability Failures (i.e., programmed zeros turning back into ones)
- Program Failures (inability to change a one to a zero), and
- Erase Failures (inability to change a zero back to a one)

Reputable flash memory vendors spend a great deal of time and effort calculating and predicting their failure rates. Published reliability reports contain these predicted failure percentages, and are available for your inspection. We'll restrict the following discussion to the last two failures listed above, program and erase (or cycling) failures.

How and why does a flash memory cell fail due to cycling? Two different mechanisms combine here; one a more “destructive” phenomenon (oxide breakdown) and the other “non-destructive” in nature (electron trapup).

Oxide Breakdown

Notice the thin oxide region between the substrate and floating gate regions in Figure 3.10. As a flash memory cell is repeatedly erased and reprogrammed, the electrons move back and forth through the oxide region under an electric field. This stresses the oxide, and in its most severe form can result in oxide breakdown and a short circuit between oxide and substrate, rendering the cell non-functional. High quality oxide with low probability of defects, as well as a lowered electric field

to minimize oxide stress, are ways that flash memory vendors can minimize the likelihood of oxide breakdown.

Electron Trapup

Recall that the earlier definition of cycling included the phrase “erased and programmed in a reasonable amount of time”. This is key to the definition of electron trapup. As a flash memory cell accumulates higher and higher cycle counts, electrons become trapped in the oxide region, lowering electron mobility through the oxide and resulting in increased program and erase times. The program and erase algorithms must apply more pulses to program or erase the cell sufficiently to ensure data integrity and retention. Since the impact of electron trapup is simply a failure to program or erase within an allowed time and not a “hard” failure of the cell itself, we call it a “non-destructive” phenomenon.

Mean Time Before Failure

With cycling and failure rate data, and with a good understanding of how flash memory will be used in your system, you can calculate MTBF values for your specific design. As an example, we'll use the Intel 28F008SA 1 Mbyte FlashFile™ memory in a configuration of 20 chips (20 Mbytes total).

The Intel 28F008SA is rated for 100,000 cycles on each of its sixteen 64 kbyte blocks (independent of any other block). Data taken through 10,000 cycles shows no cycling failures, translating to a 0% cycling failure rate (pretty impressive!). Therefore, for this example we'll use the more stringent device failure rate of .01%, which encompasses *all* device failure mechanisms listed earlier in this chapter. The value 0.01% is the historic worst-case device failure rate seen with production-rated Intel flash memories, and the 28F008SA should perform at least this well (if not better).

A 0.01% failure rate (translating to 100 FITS or failures-in-time) means that fewer than 1 in 10,000 devices will fail after 10,000 cycles and 1,000 hours of operation. The scenario under which we'll calculate MTBF assumes that a 10 kbyte file is written to the 20 Mbyte array of flash memory every 10 minutes; a pretty rigorous set of assumptions if you think about it!

A flash-friendly file system could use a linked list structure to write multiple copies of a file and fill up clean flash memory, marking old versions of the file "dirty" but not erasing them immediately⁸. This significantly minimizes cycling of flash memory media. Therefore, given the file and flash memory array sizes, we can make the following calculations:

$$\begin{aligned} (20 \text{ Mbyte array}) / (10 \text{ kbyte file}) &= 2,000 \text{ file writes can be done before an array erase is required} \\ (2000 \text{ file writes/erase}) \times (10,000 \text{ cycles per } 28\text{F}008\text{SA block}) &= 20 \times 10^6 \text{ file writes} \\ (20 \times 10^6 \text{ file writes}) \times (10 \text{ minutes/write}) \times (1 \text{ hr}/60 \text{ minutes}) &= 3.33 \times 10^6 \text{ hours MTBF} \end{aligned}$$

This means that our 20 Mbyte flash memory array has a Mean Time Between Failures of over 3 million hours, at a failure rate of 0.01%. Not bad, eh?

Extended Cycling-The Flash Memory Manufacturer's Options

Earlier when defining cycling, we inferred that the easiest way some flash memory vendors achieve extended cycling was by downplaying the negatives and accentuating the positives of their technology approaches. This, while true, is not the only means of reaching the extended cycling "Holy Grail"! Several other concrete tradeoffs have been made by various flash memory suppliers, both in technology and architecture, in pursuit of this goal.

Oxide breakdown can be eliminated by producing very high quality, uniform oxide for each flash memory cell. This is much more difficult than it might first appear, and in fact is probably the most complex problem that semiconductor vendors have struggled with as they attempt to ramp up their flash memory manufacturing capabilities. The oxide layer, at 100 Å thick, is made by laying down several layers of silicon *atoms*, no simple task. Remember, too, that for an 8 Mbit flash memory, not one cell but over 8 *million* must be manufactured correctly to yield a functional device, and that potentially several hundred devices can be made from each 6" or 8" silicon wafer.

Another technology tradeoff can be made with respect to the internal electric field during program and erase, which is a function of the

⁸See Chapter 9 for more information.

magnitude of the internal voltages. A lower electric field lowers the stress on the oxide (a positive) but also slows program and erase times (a negative). Intel Corporation, with its ETOX flash memory approach, has made this choice, and has added device functionality to minimize the system performance impact of the resultant slow block erase time⁹.

Where flash memories use higher internal voltages (flash EEPROM and NAND flash memories), added circuitry attempts to circumvent the impact of oxide breakdown and resultant cell damage. EEPROMs often use redundancy schemes which lower cycling failures at the expense of doubling cell size and adding complexity. Toshiba's NAND flash memory integrates error detection and correction (EDAC or ECC) directly on the silicon to mask the device impact of single cell failures. While potentially extending the cycling capability of the device, this approach adds complexity and die size to each device, and also impacts read performance.

Extended Cycling-What Can You Do?

What can you do to match the cycling requirements of your design to an appropriate flash memory architecture? First and foremost, fully analyze the cycling you truly require, and take all possible steps to minimize this cycling. A design that uses flash memory for embedded code storage may only be erased and reprogrammed ten times through its lifetime. On the other hand, a memory card used for file storage may have blocks of flash memory updated thousands or hundreds of thousands of times. Specifically with respect to file storage, Chapter 9 will explain how software companies have re-architected file storage beyond the hard drive paradigm to match the unique characteristics and capabilities of flash memory. These concepts, while possibly not directly applicable to your specific design, will provide examples of cycle minimization and management, linked list structures, and wear leveling.

In Chapter 7 we'll discuss the system software algorithms that initiate and control flash memory erase and program. In cases where erase failure has occurred due to non-destructive electron trapup, this chapter

⁹Upcoming chapters will discuss flash memory automation, the RY/ $\overline{\text{BY}}$ output and erase suspend/resume capability.

will show you how to extend cycling by supplying the flash memory media with additional erase and program pulses.

Finally, it's your responsibility to understand the conditions under which various flash memory vendors have calculated their products' cycling capabilities, and to request additional information if needed. By correctly interpreting not only minimum cycling information but also the failure rates associated with this cycling, you can intelligently compare and choose among the many flash memory offerings in today's market, as they match the requirements of your design.

SUMMARY

The basic concept of the flash memory cell is relatively simple. Again referencing Figure 3.3 as an example, storing electrons on the floating gate changes the stored cell data from a one to a zero, and removing them changes it back to a one. The challenge for flash memory vendors has been to make flash memory:

- Simple, with the smallest possible cell and minimal periphery logic, translating to a small die size and lowest silicon cost,
- Manufacturable, with a technology development approach that can be easily and cheaply moved to the vendor's production line, and
- Feature-set-rich, with technologies and devices that answer the requirements of their target markets.

The flash memory market is still in its infancy. The system designer has a wide range of product offerings from multiple flash memory vendors to choose from, based on several unique technology approaches. In Chapter 2, we've already covered flash memory applications in detail, and discussed the features that are of highest importance in each case. In combination with the information from this chapter, you'll be able to choose the flash memory that makes the most sense for your design!

Index

- 27C010, 134
- 28F001BX, 48
- 28F008SA, 41
- 28F010, 139
- 28F020, 139
- 28F256A, 139
- 28F512, 139

- 3.3V, 125

- 82365SL, 220, 283

- abort programming, 151
- aborting internal automation, 168
- access time, 4, 92
- adapter characteristics, 294, 332
- adapter characteristics table, 310
- address decode, 75, 99, 317
- address inputs, 194
- address latch, 76
- address space, 350
- advanced client services, 280
- Advanced Micro Devices, 25, 163
- algorithm, 30
- aliasing, 195
- alterability, 5
- applications, 2, 11
- architecture, 2
- ASCIIZ, 237, 341
- Atmel, 32, 168
- attribute memory, 193, 350, 356
- automated algorithms, 149, 162
- automated block erase, 156
- automated program/erase, 183

- background erase, 14
- bar-code scanner, 14
- basic compatibility layer, 350

- battery, 6
- battery life, 19
- battery voltage detect, 211
- benchmark, 265
- bidirectional bus interface, 130
- BIOS, 16, 70, 99, 171, 237, 275, 286, 348, 363
- bipolar, 108
- bit-alterability, 13
- bitlines, 25, 115
- block, 24, 33, 36, 83
- block erase, 29, 69, 84, 96, 115, 150, 168
- block erase algorithm, 156
- block size, 29
- Boot Block, 69, 82, 110, 131
- boot drive, 239
- bootstrap, 235
- buffer, 92, 130, 221
- buffering, 126, 222, 224
- bulk memory services, 280
- bulk-erase, 29, 115, 140, 150, 173
- bus contention, 95
- bus interface, 75
- bus transceiver, 76, 95
- bus width, 358
- busy, 84
- bypass capacitor, 112, 122, 124
- byte erase, 33, 96
- byte program, 96

- caching, 98
- capacitive loading, 90, 92, 99
- capacitors, 122
- card configuration, 361
- card detect pins, 205
- card enable, 198

- card information structure, 193, 210, 321, 350
- card insertion, 338, 347
- card insertion/removal, 222
- card interface, 349
- card offset, 315
- card physical, 349
- card removal, 338
- card reset, 206
- card services, 275, 280, 363, 368
- card status, 336, 346
- card voltage, 209
- CARDRV.EXE, 280
- Catalyst Semiconductor, 32
- \overline{CE} , 78
- cell, 4
- cell architecture, 1, 6
- cell density, 6
- cell erase, 5
- cell failure, 43
- cell redundancy, 5
- cell reliability, 5
- cell size, 24
- cell transistor, 4, 5
- cellular phone, 18
- Cerquad package, 49
- chaining, 233
- character device, 235
- chip enable, 75, 94, 99, 136
- chip erase algorithm, 143
- chip select, 75, 78, 94
- CIS, 321, 350
- CL-PD6720, 224
- clean-up, 249, 259
- clean-up efficiency, 267
- client services, 280
- client utilities, 280, 365
- cluster size, 233
- CMOS, 108, 123, 126, 131
- command interface, 134
- common memory, 193, 350, 356
- comparator, 102
- component cost, 24
- component management registers, 206
- CONFIG.SYS, 286
- configuration information, 298
- configuration option register, 207, 340
- configuration tuple, 361
- cost, 2, 4
- CPU, 4
- current draw, 24
- current limiting, 129
- current specifications, 106
- current spike, 116, 123
- cycle, 24, 32, 41
- cycle leveling, 263, 268
- cycle management, 43
- cycle minimization, 43
- cycling, 38, 40, 42, 43, 143
- cycling delta, 265
- data accumulation, 12, 14
- data bus, 76, 94, 99, 196
- data bus bandwidth, 76
- data enable, 77
- data latching, 212
- data organization layer, 350
- data path size, 320
- data polling, 167
- data verification, 138
- data/lookup tables, 14
- Databook, 224, 344
- DB86082, 221
- DC-DC converter, 208
- DDE, 241, 247
- debugging, 141
- decoupling capacitor, 112, 122
- deep powerdown, 82, 131
- deep powerdown mode, 110, 114
- defragmenting, 251
- \overline{DEN} , 77
- device addresses, 25
- device delays, 99
- device density, 5
- device driver, 233
- device geometry, 358
- device ID, 356
- device information tuple, 316
- device package, 28
- device speed code, 316
- device temperature, 32
- die size, 43
- digital cellular phone, 18
- DIP package, 46
- direct-read, 5
- directory, 231, 239
- dirty sectors, 249
- disk drive, 5, 229
- disk drive emulator, 66, 239
- disk drive template, 244
- disk imaging, 243
- domains, 229

- double-word, 76
- drain, 25
- DRAM, 2, 4, 5, 98
- driver installation, 369

- EDAC, 36
- EEPROM, 3, 5, 13, 23, 32, 43, 106, 163
- electric field, 5, 27, 29, 40, 42, 113
- electron charge, 5
- electron mobility, 41
- electron trapup, 41, 43
- embedded algorithms, 163
- embedded code, 16
- energy consumption, 114, 131
- EPROM, 2, 5, 16, 25, 48, 49, 71
- EPROM programming, 134
- erase, 27, 30, 36, 39, 41, 42, 43
- erase block size, 116, 358
- erase confirm, 145
- erase current, 116
- erase mode, 112, 115
- erase performance, 33
- erase pulse, 116
- erase setup, 145
- erase suspend, 71
- erase suspend/resume, 160
- erase time, 32, 170
- erase verify, 30, 146, 181
- erase voltage, 32, 79, 113
- erased condition, 25
- error detection, 214
- error detection and correction, 5, 36, 43, 347
- ESD protection, 127
- ETOX, 2, 25, 32, 43, 106
- ExCA, 207, 220, 277, 285, 287, 298, 348
- Exchangeable Card Architecture, 207
- execute-in-place, 228, 304
- extended cycling, 43

- failure mechanisms, 40, 41
- failure rate, 39, 40, 41, 42
- failure recovery, 269
- fanout, 108
- FAT, 231, 239, 244, 258
- FCB, 237
- FDD, 20
- feature comparison, 12
- field size, 361
- file allocation table, 231
- file control blocks, 237

- file storage, 43
- file system, 42
- file usage, 239
- firmware, 16
- FIT, 39, 41
- flash card driver, 277, 367
- flash drive, 66
- flash file system, 227, 274, 279, 368
- flash memory card, 13, 20, 57, 62
- flash memory sources, 172
- flash optimized file system, 240
- flash specifications, 86
- FlashFile, 82, 110, 131
- flight recorders, 13
- floating gate, 25, 29, 32, 40, 79, 113, 115
- foreground clean-up, 262
- forward-biasing, 129
- Fowler-Nordheim tunneling, 28, 33, 36
- FSSD, 227
- Fujitsu, 25, 214
- full erase, 116

- garbage, 250
- GetAdapter, 302
- GetAdapterCount, 289
- GetPage, 312
- GetSocket, 331
- GetSSInfo, 290, 342, 344
- GetStatus, 340, 345, 346
- GetVendorInfo, 343
- GetWindow, 309
- glitch detect, 78
- glue-logic, 273

- handheld instrumentation, 14
- hardware interfacing, 73, 187
- hardware interleaving, 99
- hardware interrupt, 170
- HCT, 126
- HDD, 15
- high-speed specifications, 90
- Hitachi, 25, 168
- hold time, 96
- hot electron injection, 27, 34
- hot insertion, 62

- I/O access, 212
- I/O mapping, 214, 293
- I/O space, 304
- IDE, 66, 228

- identification and revision register, 305
- IDT, 130
- in-system write, 71
- indirect indexing, 283
- input voltage specifications, 126
- InquireAdapter, 292, 299, 303, 310, 325, 330, 334
- InquireSocket, 333, 335, 336
- InquireWindow, 304, 318, 319, 321, 322, 325, 326, 357
- installable device driver, 233
- INT 13H, 235, 243
- INT 1AH, 285
- INT 21H, 237, 253, 265
- INT 25H, 236, 243
- INT 2FH, 253
- integrated converter, 122
- Integrated Device Technology Corporation, 130
- integrated drive, 228
- integration, 133
- Intel, 25, 149, 189
- interface controller, 220, 283
- interface logic, 102
- interface status register, 283
- interleaving, 14, 95, 99, 103, 359
- internal automation, 82, 151, 163
- internal voltage, 5, 43
- internal voltage conversion, 113
- interrupt filter, 206, 242
- interrupt latency, 203
- interrupt request, 200
- interrupts, 141, 225, 299, 333, 345
- IO.SYS, 233
- ISA, 330

- J-Lead, 49
- JEDEC, 69, 91
- JEDEC identifier, 360
- JEIDA, 62, 188
- JIT, 70
- just-in-time, 70

- laser printer, 15
- LCC package, 49
- leakage current, 114
- lifetime, 24
- linear mapped memory, 214
- Linear Technology Corporation, 118
- linked list, 258
- linked list structures, 43

- lithographies, 28
- locality, 100
- lockout voltage, 78

- M-Systems, 247
- magnetic mass storage, 3, 5, 6, 19
- manufacturability, 2
- manufacturing, 24, 42
- market share, 24
- mass file storage, 19
- MAX705, 81
- Maxim Integrated Products, 119
- MDT4P05, 80
- medical instrumentation, 12
- memory banks, 359
- memory card, 62, 187
- memory card offset, 328
- memory characteristics table, 305
- memory comparison, 6
- memory density, 13
- memory lifetime, 5
- memory mapping, 212, 214
- memory output, 25
- memory space, 304
- memory technology driver, 277, 281
- metaformat, 349
- microcontroller, 219
- Microsoft, 252, 253
- Mitsubishi, 25
- mixed-voltage bus, 130
- mixed-voltage design, 125
- modular solutions, 122
- monolithic file system, 279
- MOSFET, 130
- Motorola, 77, 80, 118
- MS Flash File System, 252
- MS-FLASH.SYS, 279
- MTBF, 38, 41, 42
- MTD, 277
- multiple block erase, 168
- multiplex interrupt, 253
- multiplexing, 76

- NAND, 23, 36, 43, 106, 168
- NEC, 25, 168
- negative gate erase, 29
- non-destructive failure, 41
- nonvolatile, 4, 6
- nonvolatility, 16, 23
- NOR, 23, 26, 30, 80, 106

- $\overline{\text{OE}}$, 77, 78
- on-board update, 69
- on-chip buffer, 33
- open-drain output, 130
- operating range, 90
- operating voltage, 106
- OTP-ROM, 49
- output buffer, 99, 109
- output bus, 95
- output drive, 92
- output enable, 76, 199
- output enable time, 92
- output loading, 99
- overerase, 29
- oxide, 25, 32
- oxide breakdown, 5, 40
- oxide thickness, 33, 35

- packaging, 45
- page, 102
- page enable, 326
- page programming, 168
- paged memory mapping, 217
- paging, 222
- parallel erase, 175, 179
- parallel programming, 175, 176
- PBX switcher, 14
- PC card interface controller, 220
- PCIC, 283, 298, 305, 323
- PCMCIA, 20, 62, 187, 210, 211, 219, 220, 223, 277, 285, 287, 305, 348, 349, 354, 363
- PCMCIA card types, 63
- PCMCIA-ATA, 66, 228
- performance, 14, 102, 265
 - program/erase, 23
 - read, 23
- Performance Semiconductor, 130
- periphery logic, 24, 36
- $\overline{\text{PGM}}$, 136
- pinout, 73
- platter seek, 5
- PLCC, 49
- point of sale terminals, 13
- portability, 13
- portable computer, 20
- power, 5, 14
- power consumption, 80, 82, 105, 113, 130, 132
- power management, 108, 294, 296
- power management table, 334
- power management techniques, 130
- power profile, 113
- power transitions, 83
- powerdown, 82, 110
- powerdown mode, 114
- POWERGOOD, 84
- pre-condition, 143
- preprogramming, 30, 143
- pricing, 2
- processor loading, 76
- production volume, 1
- program, 41, 42, 43, 96
- program mode, 111, 115
- program setup, 140
- program verification, 151
- program verify, 115, 140, 141, 142
- program voltage, 79, 112, 113
- program/erase performance, 23
- program/erase voltage, 138
- programming, 27
- programming algorithm, 138
- programming current, 115
- programming voltage, 207
- PROM, 4
- PROM programmer, 70
- PROM programming, 68
- protected mode, 344
- PSOP, 51
- pulse count, 140
- $\overline{\text{PWD}}$, 69

- RAM, 3, 77
- RAM interface, 71
- RAMDRIVE, 228
- ramp delay, 132
- READ, 78
- read, 76, 103, 114
- read access, 99, 101
- read access time, 36, 99
- read array mode, 161
- read block size, 358
- read current, 108
- read current profile, 108
- read cycle time, 93
- read delay, 94, 102
- read mode, 108
- read performance, 23, 43, 92
- read status register, 160
- read timing, 93
- read/write, 77
- ready/busy, 84, 200
- real-time clock, 141

- reclamation, 247
- redirector, 253
- redundancy, 5, 43
- refresh, 6
- $\overline{\text{REG}}$, 193
- register-based memory mapping, 212
- reliability, 32, 35, 40, 99, 113, 117, 122, 128, 268
- remote sensing, 14
- removability, 291
- $\overline{\text{RESET}}$, 81, 206
- reset, 82, 169, 173, 340
- resource management, 280, 364
- reverse pinout, 57
- rewrite, 5, 33
- ROM, 3, 16, 77
- ROM drive, 243
- ROM scan, 286
- root directory, 244
- rotation delay, 5
- RP, 69
- $\text{RY}/\overline{\text{BY}}$, 82

- Samsung, 32
- saturation, 108
- SCM, 247
- sector, 229, 239, 246
- select gate, 25, 36
- sensing instrumentation, 14
- Series 1 Card, 139, 188
- Series 2 Card, 200, 203, 206
- serpentining, 57
- SetAdapter, 296, 303, 309, 333, 345, 347
- SetPage, 313, 315, 329
- SetSocket, 301, 337, 347
- setup command, 151
- setup time, 95
- SetWindow, 298, 314, 323, 326
- SGS-Thompson, 25
- shadowing, 98
- shock tolerance, 13
- signal states, 91
- silicon, 42
- silicon oxide, 25
- SIMM package, 59
- socket characteristics, 332
- socket configuration, 337
- socket services, 220, 222, 281, 284, 348
- socket windows, 293
- software algorithms, 43
- software delay, 141
- software delay loop, 81
- software interface, 174
- software metaformat, 349
- software polling, 170
- SOJ package, 54
- solid-state drive, 227
- SOP package, 54
- source, 25, 29
- spare block, 249
- specifications, 90, 106
- SRAM, 4, 5, 13, 19, 98
- standby, 114, 131
- standby mode, 109
- state machine, 151, 161
- status change interrupt, 282
- status register, 84, 151, 153, 158, 160, 169
- stop timers, 141, 146
- substrate, 25, 40
- SunDisk, 32
- supply voltage, 106
- suspend/resume, 160
- switching, 108
- system cost, 99
- system performance, 98
- system reset, 82

- TCIC-2/N, 221, 224
- temperature tolerance, 13
- test conditions, 108
- testing, 349
- Texas Instruments, 130
- timing parameters, 85
- toggle bit, 167
- Toshiba, 25, 36, 168
- transceiver, 76, 92, 95
- transistor, 4
- transistor gate, 115
- transistor source, 25, 115
- transition points, 90
- tri-state, 130
- TSOP package, 48, 54, 69
- TTL, 108, 125
- tunneling, 28
- tuple, 316, 352, 361
- tuple byte, 354
- tuple chain, 354
- tuple code, 353
- tuple field, 354
- tuple link, 353
- tuple list, 353, 354

- ultraviolet light, 28
- update, 68, 170
- update methods, 45
- update performance, 113
- updateability, 6, 23
- UV, 28

- V_{CC}-only, 106
- VDISK, 228
- vendor release, 342
- verify, 143, 178
- verify voltage, 113
- virtual addressing, 249
- voltage conversion, 113, 118
- voltage converter, 79
- voltage converter features, 121
- voltage droop, 118
- voltage monitoring, 81
- voltage ramp, 81, 115
- voltage ramp rates, 129
- voltage requirements, 24
- voltage sense, 210
- voltage spikes, 122
- voltage switching, 80, 208
- voltage tolerance, 117
- voltage translation, 126, 130
- volume growth, 1
- V_{PP} feedback, 81

- $\overline{\text{WAIT}}$, 204
- wait states, 102, 321
- wakeup, 110, 131
- $\overline{\text{WE}}$ -less memory, 78
- wear leveling, 43
- window, 304, 306
- window base address, 308, 310, 322
- window enable, 319
- window number, 325
- window page, 311, 325
- window size, 309, 314, 318
- window state, 319
- wire or, 203
- word, 76
- wordlines, 25, 115
- WORM, 253
- wrap-around, 195
- $\overline{\text{WRITE}}$, 78
- write, 33, 103
- write cycle time, 95
- write enable, 77, 199
- write performance, 131

- write protect, 78, 199, 312, 326, 357
- write state machine, 151

- XIP, 228, 304

You are welcome to send us comments or questions concerning this or other Annabooks products, or to request a catalog of our products and seminars.

Annabooks
11848 Bernardo Center Drive, Suite 110
San Diego, CA 92128

616-673-0870

1-800-462-1042

616-673-1432 FAX