



INTERNATIONAL APPLICATION PUBLISHED UNDER THE PATENT COOPERATION TREATY (PCT)

<p>(51) International Patent Classification ⁶ : A61F 2/06</p>	<p>A1</p>	<p>(11) International Publication Number: WO 99/29262 (43) International Publication Date: 17 June 1999 (17.06.99)</p>
<p>(21) International Application Number: PCT/AU98/01019 (22) International Filing Date: 9 December 1998 (09.12.98) (30) Priority Data: PP 0835 10 December 1997 (10.12.97) AU (71) Applicant (for all designated States except US): WILLIAM A. COOK AUSTRALIA PTY. LTD. [AU/AU]; 12 Electronics Street, Brisbane Technology Park, Eight Mile Plains, QLD 4113 (AU). (72) Inventors; and (75) Inventors/Applicants (for US only): HARTLEY, David, Ernest [AU/AU]; 2 View Street, Subiaco, W.A. 6008 (AU). BROWNE, Thomas, Francis [IE/GB]; 29 Oak Lodge Tye, Springfield, Chelmsford, Essex CM1 6GY (GB). (74) Agent: COLLISON & CO.; 117 King William Street, Adelaide, S.A. 5000 (AU).</p>	<p>(81) Designated States: AL, AM, AT, AU, AZ, BA, BB, BG, BR, BY, CA, CH, CN, CU, CZ, DE, DK, EE, ES, FI, GB, GD, GE, GH, GM, HR, HU, ID, IL, IN, IS, JP, KE, KG, KP, KR, KZ, LC, LK, LR, LS, LT, LU, LV, MD, MG, MK, MN, MW, MX, NO, NZ, PL, PT, RO, RU, SD, SE, SG, SI, SK, SL, TJ, TM, TR, TT, UA, UG, US, UZ, VN, YU, ZW, ARIPO patent (GH, GM, KE, LS, MW, SD, SZ, UG, ZW), Eurasian patent (AM, AZ, BY, KG, KZ, MD, RU, TJ, TM), European patent (AT, BE, CH, CY, DE, DK, ES, FI, FR, GB, GR, IE, IT, LU, MC, NL, PT, SE), OAPI patent (BF, BJ, CF, CG, CI, CM, GA, GN, GW, ML, MR, NE, SN, TD, TG). Published With international search report.</p>	

(54) Title: ENDOLUMINAL AORTIC STENTS

(57) Abstract

A prosthesis comprises Z stents (7, 8) sutured to a graft (5) comprising a bio-compatible material tube such as dacron. The Z stents are attached to the inside surface of the dacron tube and there is at least one fenestration (10) in the dacron tube corresponding to an intersecting artery opening. A further Z stent (1) extends proximally and they may have caudally facing barbs (2). Each fenestration includes one or more radiopaque markers defining a periphery of the fenestration. A release mechanism for said prosthesis includes trigger wires stitched into a fold on the dacron to retain the prosthesis in a partially compressed state during deployment. A delivery device has a sheath to hold the compressed prosthesis during insertion and a top cap to retain the top stent.

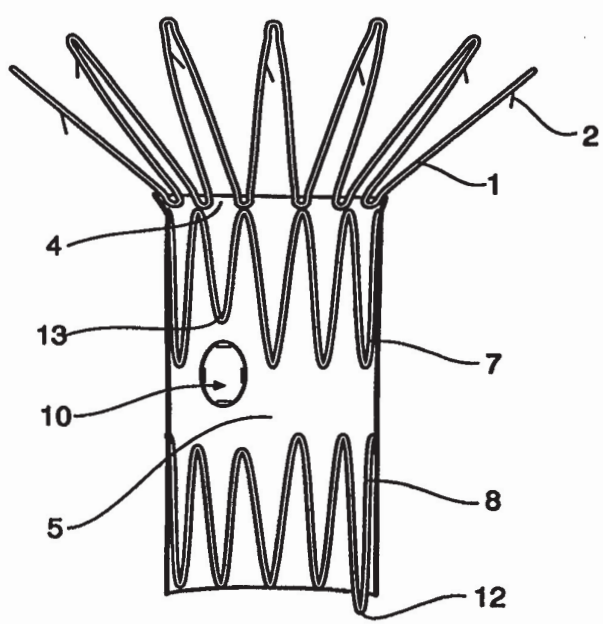

FOR THE PURPOSES OF INFORMATION ONLY

Codes used to identify States party to the PCT on the front pages of pamphlets publishing international applications under the PCT.

AL	Albania	ES	Spain	LS	Lesotho	SI	Slovenia
AM	Armenia	FI	Finland	LT	Lithuania	SK	Slovakia
AT	Austria	FR	France	LU	Luxembourg	SN	Senegal
AU	Australia	GA	Gabon	LV	Latvia	SZ	Swaziland
AZ	Azerbaijan	GB	United Kingdom	MC	Monaco	TD	Chad
BA	Bosnia and Herzegovina	GE	Georgia	MD	Republic of Moldova	TG	Togo
BB	Barbados	GH	Ghana	MG	Madagascar	TJ	Tajikistan
BE	Belgium	GN	Guinea	MK	The former Yugoslav Republic of Macedonia	TM	Turkmenistan
BF	Burkina Faso	GR	Greece			TR	Turkey
BG	Bulgaria	HU	Hungary	ML	Mali	TT	Trinidad and Tobago
BJ	Benin	IE	Ireland	MN	Mongolia	UA	Ukraine
BR	Brazil	IL	Israel	MR	Mauritania	UG	Uganda
BY	Belarus	IS	Iceland	MW	Malawi	US	United States of America
CA	Canada	IT	Italy	MX	Mexico	UZ	Uzbekistan
CF	Central African Republic	JP	Japan	NE	Niger	VN	Viet Nam
CG	Congo	KE	Kenya	NL	Netherlands	YU	Yugoslavia
CH	Switzerland	KG	Kyrgyzstan	NO	Norway	ZW	Zimbabwe
CI	Côte d'Ivoire	KP	Democratic People's Republic of Korea	NZ	New Zealand		
CM	Cameroon			PL	Poland		
CN	China	KR	Republic of Korea	PT	Portugal		
CU	Cuba	KZ	Kazakstan	RO	Romania		
CZ	Czech Republic	LC	Saint Lucia	RU	Russian Federation		
DE	Germany	LI	Liechtenstein	SD	Sudan		
DK	Denmark	LK	Sri Lanka	SE	Sweden		
EE	Estonia	LR	Liberia	SG	Singapore		

TITLE

ENDOLUMINAL AORTIC STENTS

INTRODUCTION

The present invention relates generally to the field of the treatment of aortic
5 disease and in particular to endoluminal aortic stents and a method of
deployment of such stents which allows accurate placement of a covered
stent in the aorta. In particular it is capable of being deployed and
positioned accurately above the renal arteries in the treatment of infra-renal
aortic aneurysmal disease.

10 BACKGROUND OF THE INVENTION

According to the prior art, aortic disease is often treated by surgical
techniques involving the use of stents and grafts. For example, it is well
known in the art to interpose, within the stenotic portion of an artery, a stent,
whether made of stainless steel or other materials, capable of being
15 balloon-expandable for strengthening the walls of a stenotic or occluded
artery. In addition, it is well known in the prior art to use a graft to repair
highly damaged portions of, for example, the aorta or other arteries thereby
ensuring blood flow and reducing the risk of aneurisms or ruptures. The
grafts, hollow tubes comprised of material such as dacron, are normally
20 inserted within the walls of a damaged artery and can be sewn into position
or expanded through the use of a stented balloon catheter.

A more severe problem occurs when it is necessary to use a graft at or
around the intersection of a major artery (eg. the aorta) with intersecting
arteries (eg. the renal arteries, carotid or brachycephalic artery). While the
25 graft is clearly required to strengthen and ensure the flow of blood through,
for example, the aorta, the use of a graft effectively seals or blocks off the
blood flow to the kidneys or cerebral circulation. Accordingly, it is often
impossible or impractical to use a graft to treat aortic disease at or around
the intersection of the aorta and other arteries. Instead a surgeon must
30 attempt to repair the weakened walls of such artery using other surgical

techniques having high failure rates and limited success. For example, although several centres around the world have been routinely deploying endoluminal grafts for the treatment of infra-renal aortic aneurisms, as many as 30% of abdominal aortic aneurisms are unsuitable for this method of
5 treatment due to an insufficient length of aneurysmal-free infra-renal aorta to firmly anchor the graft or stent.

The present invention solves the problem in the prior art by utilising the supra-renal aorta to provide adequate anchorage for an aortic graft whilst at the same time employing extremely accurate placement of a fenestrated
10 covered stent which corresponds to the exact sites of origin of the intersecting arteries.

BRIEF DESCRIPTION OF THE INVENTION

The present invention in general relates to a fenestrated endoluminal aortic stent which is a single component device comprising two or more stainless
15 steel or nitinol Z stents which may have caudal facing barbs sutured to a variable length of a bio-compatible material tube in which the Z stents are attached to the inside surface of the bio-compatible material tube and, depending on the geometry of the intersecting arteries to be covered, customised fenestrations accurately placed in the bio-compatible material
20 tube corresponding to the intersecting artery openings.

In one form, therefore, the invention may be said to reside in a prosthesis comprising two or more Z stents sutured to a graft comprising a bio-compatible material tube, wherein the two or more Z stents are attached to the inside surface of the bio-compatible material tube and at least one
25 fenestration in the bio-compatible material tube corresponding to an intersecting artery opening.

Preferably there are more than two Z stents attached to the bio-compatible material tube.

There may be a further Z stent fastened to the bio-compatible material tube
30 and extending proximally from the bio-compatible material tube.

3

At least one of the Z stents may have caudally facing barbs thereon to assist with accurate retention of the prosthesis when completely inserted.

The proximally extending Z stent may be the stent which has the caudally facing barbs thereon.

- 5 The bio-compatible material tube may in one embodiment be a dacron material tube.

There may be two or more fenestrations according to the number of intersecting arteries.

- 10 The or each fenestration may include one or more radiopaque markers defining a periphery of the fenestration.

The distal most of the Z stents may include a loop extending distally of the graft.

- 15 The prosthesis may further include a release mechanism for said prosthesis including one or more trigger wires wherein a portion of the bio-compatible material tube is folded longitudinally with the one or more trigger wires respectively threaded longitudinally through the bio-compatible material tube at the fold to retain the prosthesis in a partially compressed state.

At least one of the Z stents may include one or more shortened loops to enable location of the fenestrations as required.

- 20 Accurate siting of the branches of the aorta may be achieved from Computerised Axial Tomograms (CT) and angiography and the invention is customised to each patient in relation to the sites corresponding with the CT. The fenestrations are marked with radiopaque beads to facilitate their positioning under X-ray control before deployment.

- 25 In an alternative form the invention may be said to reside in a method for treating arterial disease at an intersection of two arteries, including the steps of:
X-raying arteries to be treated so as to accurately determine the position of

4

the intersection of the arteries, customising one or more fenestrations to a prosthesis comprising a selected length of a bio-compatible material tube, attaching radiopaque markers around the or each fenestrations, placing two or more Z stents into said bio-compatible material tube, bends in the Z

5 stents being shortened if necessary in such a way so as not to cover the fenestrations, manually gathering a top Z stent, covering the top Z stent with a top cap and holding the Z stent in place in the top cap with a trigger wire, stitching the trigger wire or another trigger wire through a longitudinal fold in the bio-compatible material tube to narrow the diameter of said prosthesis

10 thereby providing a customised fenestrated covered graft to be inserted into an artery to be treated.

The method may further include the step of sewing a further Z stents to top ring of said bio-compatible material tube, such that the further Z stent extends proximally from the bio-compatible material tube.

15 There may be more than two said Z stents attached to the bio-compatible material tube and two or more than two fenestrations according to the number of intersecting arteries.

The process of insertion of the graft may include the steps of; compressing the graft and placing it into a sheath which fits snugly around said top cap,

20 said prosthesis, the Z stents and an obturator, inserting through a femoral artery in a groin said prosthesis using a delivery device which includes said top cap, said sheath, said obturator and guide wires, withdrawing said sheath to reveal said graft in semi-deployed position, positioning the prosthesis, partially withdrawing said sheath and obturator to enable

25 insertion of angiography catheters and guide wires, inserting said angiography catheters and guide wires through a contralateral groin into the artery to be treated to provide manoeuvrability, and accurate positioning of the graft by positioning right and left angiography catheters and guide wires through the fenestrations into the intersecting arteries, releasing the

30 trigger wire to provide full deployment of the said graft, withdrawing said angiography catheters and pushing up said sheath and obturator through said stent and docking with said top cap and fully withdrawing said delivery device, whereby the said fully deployed stent ensures the flow of blood at the intersection of the arteries to be treated.

5

The method by which the prosthesis of the present invention may be manoeuvred into place prior to full deployment is by way of the right and left angiography catheters and guide wires.

5 The radiopaque markers may be gold or any other bio-compatible material which enables the marker to be visualised by X-ray or other methods.

This generally describes the invention but to assist with understanding of the invention reference will now be made to preferred embodiments of the invention with the assistance of the following drawings.

BRIEF DESCRIPTION OF THE DRAWINGS

10 One embodiment of the present invention will now be described with reference to the drawings in which:

15 FIG. 1 is an outside view of one embodiment of the present invention illustrating the top Z stents, bio-compatible material tube with fenestrations and small radiopaque beads and metal loop at the base of the bio-compatible material tube;

FIG. 2 is an inside view of the embodiment of the present invention illustrating the internal Z stents and their relationship with the fenestrations for the intersecting arteries;

20 FIG. 3 is an outside perspective view of the embodiment of the present invention illustrating how the material of the bio-compatible material tube may be folded back and held in place by a threaded trigger wire. The Z stents attached to the inside surface of the material of the bio-compatible material tube are incomplete posteriorly to allow a section of the material of the bio-compatible material tube to be folded and held with a trigger
25 wire threaded through the material;

FIG. 4 is a cross-section view of the embodiment of the present invention before release of the trigger wire;

6

FIG. 5 is a cross-section view of the embodiment of the present invention after release of the trigger wire. The trigger wire has been withdrawn and the folded bio-compatible material unfurled, allowing the stent to expand to its full extent, holding it against the aortic wall with a radial force;

5 FIG. 6 is a view of the aorta and renal arteries with the prosthesis of this embodiment of the present invention within the delivery device. The top Z stents of the present invention have been manually pulled together and covered with a top cap whilst the lower part of the present invention sits snugly above the obturator and within the sheath which are all threaded
10 over a guide wire which mounts the present invention to the correct position;

FIG. 7 is a view of the prosthesis of this embodiment of the present invention after its release from the sheath in a semi-deployed position opposite the renal arteries, that is before release of the trigger wire;

15 FIG. 8 is a view of the prosthesis of this embodiment of the present invention in a semi-deployed position where the fenestrations of the present invention have been cannulated by a guide wire from the contralateral groin over which two angiography catheters have been passed in order to fix the stent firmly in the correct positions prior to full
20 deployment, that is prior to release of the trigger wire;

FIG. 9 is a view of the prosthesis of this embodiment of the present invention in full deployment, that is after release of the trigger wire with the angiography catheters and top cap still in place;

25 FIG. 10 is a view of the prosthesis of this embodiment of the present invention in full deployment with the angiography catheters and their guide wires withdrawn, and the sheath and obturator of the delivery device pushed up to dock with the top cap in preparation for withdrawal of the delivery device; and

30 FIG. 11 is a view of the prosthesis of this embodiment of the present invention in full deployment preserving flow to the renal arteries with the sheath, obturator and top cap withdrawn.

DESCRIPTION OF A PREFERRED EMBODIMENT OF THE INVENTION

The present invention relates generally to the field of the treatment of aortic disease and in particular to endoluminal aortic stents which allow accurate placement of a fenestrated covered stent in the aorta. In particular it is
5 capable of being deployed and positioned accurately above the renal arteries in the treatment of infra-renal aortic aneurysmal disease.

The drawing figures illustrate the basic steps comprising the method as well as illustrating the features of one embodiment of the present invention.

FIGS. 1 and 2 show an outside view of one embodiment of the present
10 invention. A proximal stainless steel or nitinol Z stent 1 with caudal facing barbs 2 is stitched to a top ring 4 of a bio-compatible material tube 5. The proximal Z stent 1 extends proximally from the bio-compatible material tube 5. Two further stainless steel or nitinol Z stents 7 and 8 are fitted within the bio-compatible material tube 5. The Z stents are stitched at intervals to the
15 bio-compatible material tube but in part of the bio-compatible material tube stitching is omitted to enable a longitudinal fold to be made in the bio-compatible material tube as will be discussed later. Fenestrations 10 are provided in the bio-compatible material tube 5 providing an aperture in the tube which will in use align with the renal or other arteries. The
20 fenestrations 10 are customised in size and position for the renal arteries following computer tomography and angiography and their peripheral edges are marked with small gold radiopaque beads 11 which help to identify the fenestrations with X-rays. There is a long loop 12 in one of the crowns of the Z stent 8 which extends distally of the bio-compatible material
25 tube 5 and which holds the anterior of the stent within the delivery device as will be discussed later.

As can be particularly seen in FIG. 2, which shows the inside view of the prosthesis, there is a shortened loop 13 of one of the crowns of the top inner Z stent 7 which permits placement of the fenestrations for the renal arteries
30 at the desired position.

FIG. 3 is an perspective view of the prosthesis where the proximal crowns 14 of the Z stent 1 have been drawn together manually to facilitate their

insertion into a proximal capsule (not shown). A trigger wire 17 is used to retain the crowns within the capsule. The same trigger wire or another trigger wire 15 is also used to retain a longitudinal tuck in the bio-compatible material tube 5 thus narrowing the diameter and leaving a fold 16 of excess material to the side of the prosthesis. The trigger wire 17 also passes through the loop 12 to assist with retaining the distal end of the prosthesis after withdrawal of the sheath as will be discussed later. This enables rotation of the prosthesis within the artery to accurately position it before final release. The trigger wire 15 is inserted through the surface of the dacron or other material intermittently to create a series of stitches to form the seam-like fold of material 16 as more clearly depicted in FIG. 4.

FIG. 4 shows a cross section view of the prosthesis before release of the trigger wire 15 from the fold 16 of material. The seam-like fold 16, held in place by the stitched-on trigger wire 15, provides a diameter which is narrower than the diameter of the aorta thereby enabling the prosthesis to be manoeuvred both up and down and rotationally 360 degrees, on release of the present invention from a sheath, and after catheterisation as will be discussed in reference to FIG. 8, to ensure accurate placement of the fenestrations in relation to the renal arteries.

FIG. 5 shows a cross section view of the prosthesis after release of the trigger wire. ie. in full deployment.

FIG. 6 is a view of the aorta 30, renal arteries 32 and 34 extending to the kidneys 35 and femoral arteries 36 and 38 and the delivery device which introduces the prosthesis 18 of the present invention to the aorta 30 via a groin incision to one of the femoral arteries 36.

The delivery device generally shown as 20 is inserted over a plastic covered metal guide wire 22 and comprises a stainless steel proximal cap 24 mounted on a flexible steel tube 23. The proximal cap 24 covers the top part of the proximal Z stent and a sheath 26 covering the prosthesis including bio-compatible material tube 5 and the remainder of the Z stents and extends over part of the proximal cap 24 during insertion. The sheath 26 is fitted over a plastic obturator 28 which is sufficiently long to protrude from the femoral artery and groin incision to enable manual movement

thereof. The plastic obturator 28 is a sliding fit on the flexible steel tube 23. The obturator 28 sits snugly under the sheath and holds the prosthesis in position both on insertion and later when the sheath is drawn back over the obturator as depicted in FIG. 7 thereby exposing the fenestrated stent in the
5 semi-deployed position illustrated in FIGS. 3.

In FIG. 7 the sheath 26 has been withdrawn onto the obturator 28 while leaving the obturator 28 and the proximal capsule 24 in place by preventing relative movement between the flexible steel tube 23 and the obturator 28. The prosthesis 18 is then free to be rotated by movement of the flexible tube
10 23 and moved longitudinally until the fenestrations 10 and 11 are positioned correctly with respect to the renal arteries 32 and 34.

FIG. 8 is a view of the aorta 30, renal arteries 32 and 34 extending to the kidneys 35 and femoral arteries 36 and 38 and the delivery device 20 where the obturator 28 and sheath 24 have been withdrawn back to one of
15 the femoral arteries 36. This is achieved by holding the flexible steel tube 23 stationary and moving the sheath 26 and obturator 28 relative to it. The trigger wire 15 remains in place. This allows room for the introduction of the guide wires 40 and 42 and angiography catheters 44 and 46 that have been inserted via an incision in the contralateral groin (not shown) and up
20 through the contralateral femoral artery 38 and placed in the renal arteries as directed by the right and left angiography catheters 44 and 46. These angiography catheters 44 and 46 are designed with right and left bended necks respectively so as to guide the wire from the aorta 30 in to the appropriate renal artery 32 and 34. The guide wires 40 and 42 and
25 angiography catheters 44 and 46 are inserted into the renal arteries 32 and 34 so as to safely and accurately position the fenestrations 10 and 11 of the prosthesis of this embodiment of the present invention.

FIG. 9 is a view of the present invention in full deployment after release of the trigger wires 15 and 17 or the single trigger wire carrying out the
30 functions of both trigger wires with the guide wires 40 and 42, angiography catheters 44 and 46 and delivery device 20 still in place. At this stage the proximal Z stent 1 expands out to the wall of the aorta 30 and the barbs 2 engage in to the wall of the aorta to retain the prosthesis 18 in the correct position.

10

In FIG. 10 the angiography catheters 44 and 46 and guide wires 40 and 42 have been withdrawn through the contralateral femoral artery 38 and the obturator 28 and sheath 24 have been pushed up to dock with the proximal capsule 24 in preparation for removal of the complete delivery device 20.

5 This is achieved by holding the flexible steel tube 23 stationary and moving the obturator 28 and sheath 24 relative to it and towards the proximal capsule.

FIG. 11 is a view of the prosthesis 18 of the present invention in full deployment, with the delivery device 20 withdrawn, enabling free flow of
10 blood through the aorta 30 and into the renal arteries 32 and 34 via the fenestrations 10 and 11.

Post-deployment angiography should be carried out to confirm correct deployment and positioning of the fenestrations.

15 Modifications which can be made which may be advantageous are as follows.

There may be more than two Z stents attached to, and within, the bio-compatible material tube. More than two Z stents would be used if elongation of the graft of the present invention is required.

20 The release mechanism may be folded internally either (a) posteriorly or (b) anteriorly and posteriorly with one or two trigger wires respectively.

There may be more than two fenestrations in the bio-compatible material tube where there are more than two intersecting arteries.

25 Throughout this specification and the claims that follow unless the context requires otherwise, the words 'comprise' and 'include' and variations such as 'comprising' and 'including' will be understood to imply the inclusion of a stated integer or group of integers but not the exclusion of any other integer or group of integers.

CLAIMS

1. A prosthesis comprising two or more Z stents sutured to a graft comprising a bio-compatible material tube, wherein the two or more Z stents are attached to the inside surface of the bio-compatible material tube and at
5 least one fenestration in the bio-compatible material tube corresponding to an intersecting artery opening.
2. A prosthesis according to claim 1 wherein there are more than two Z stents attached to the bio-compatible material tube.
3. A prosthesis according to claim 1 further including a further Z stent
10 fastened to the bio-compatible material tube and extending proximally from the bio-compatible material tube.
4. A prosthesis according to any one preceding claim wherein at least one of the Z stents has caudally facing barbs thereon.
5. A prosthesis according to claim 3 wherein the proximally extending
15 Z stent has caudally facing barbs thereon.
6. A prosthesis according to any one preceding claim wherein there are two or more fenestrations according to the number of intersecting arteries.
7. A prosthesis according to any one preceding claim wherein the or
20 each fenestration includes one or more radiopaque markers defining a periphery of the fenestration.
8. A prosthesis according to any one preceding claim wherein the distal most of the Z stents includes a loop extending distally of the graft.

9. A prosthesis according to any one preceding claim further including a release mechanism for said prosthesis including one or more trigger wires wherein a portion of the bio-compatible material tube is folded longitudinally with the one or more trigger wires respectively threaded
5 longitudinally through the bio-compatible material tube at the fold to retain the prosthesis in a partially compressed state.
10. A prosthesis according to any one preceding claim wherein at least one of the Z stents includes one or more shortened loops to enable location of the fenestrations as required.
- 10 11. A method for treating arterial disease at an intersection of two arteries, including the steps of:
- X-raying arteries to be treated so as to accurately determine the position of the intersection of the arteries,
- 15 customising one or more fenestrations to a prosthesis comprising a selected length of a bio-compatible material tube;
- attaching radiopaque markers around the or each fenestrations;
- placing two or more Z stents into said bio-compatible material tube, bends in the Z stents being shortened if necessary in such a way so as not to cover the fenestrations;
- 20 manually gathering a top Z stent, covering with the top Z stent with a top cap and holding the top cap in place with a trigger wire;
- stitching a trigger wire through a longitudinal fold in the bio-compatible material tube to narrow the diameter of said graft;
- 25 thereby providing a customised fenestrated covered graft to be inserted into an artery to be treated.

13

12. A method as in Claim 11 further including the step of sewing a further Z stents to top ring of said bio-compatible material tube, such that the further Z stent extends proximally from the bio-compatible material tube.

5 13. The method as in claim 11 wherein the process of insertion of the graft includes the steps of;

compressing the graft and placing it into a sheath which fits snugly around said top cap, said prosthesis, the Z stents and an obturator;

10 inserting through a femoral artery in a groin said prosthesis using a delivery device which includes said top cap, said sheath, said obturator and guide wires;

withdrawing said sheath to reveal said graft in semi-deployed position;

positioning the prosthesis:

partially withdrawing said sheath and obturator to enable insertion of angiography catheters and guide wires;

15 inserting said angiography catheters and guide wires through a contralateral groin into the artery to be treated to provide manoeuvrability, and accurate positioning of the graft by positioning right and left angiography catheters and guide wires through the fenestrations into the intersecting arteries;

20 releasing the trigger wire to provide full deployment of the said graft;

withdrawing said angiography catheters;

pushing up said sheath and obturator through said stent and docking with said top cap and fully withdrawing said delivery device;

25 whereby the said fully deployed stent ensures the flow of blood at the intersection of the arteries to be treated.

14

13. The method according to claim 11 wherein there are more than two said Z stents attached to the bio-compatible material tube.
14. The method according to claim 11 wherein there are two or more than two fenestrations according to the number of intersecting arteries.
- 5 15. The method according to claim 11 wherein the radiopaque markers are gold or any other bio-compatible material which enables the marker to be visualised by X-ray or other methods.

1/8

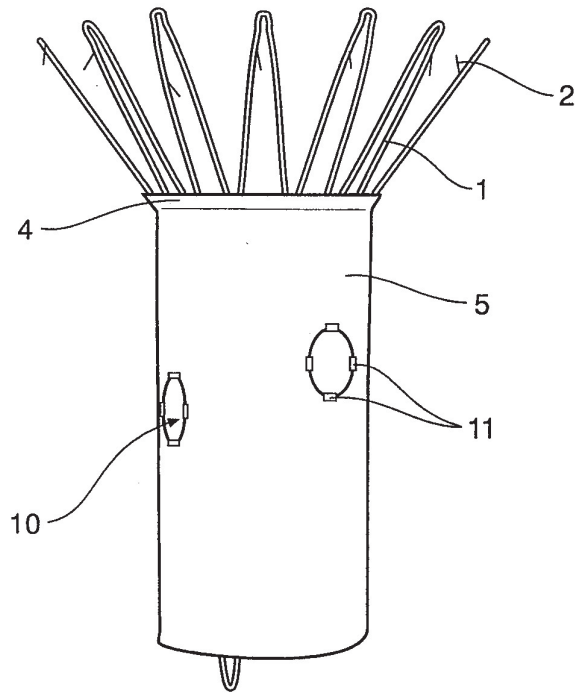

FIG 1

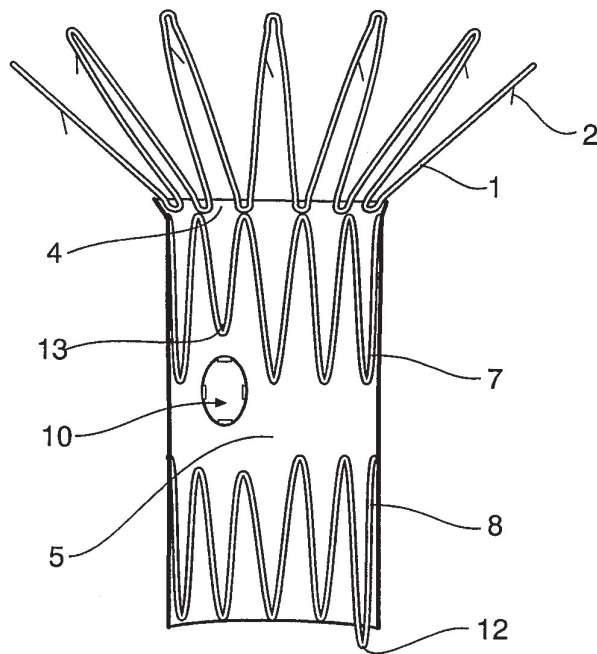

FIG 2

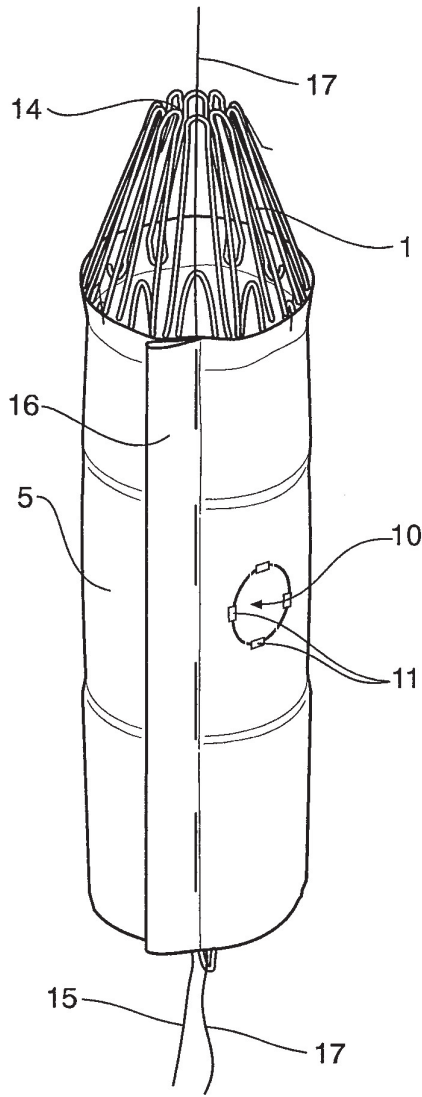

FIG 3

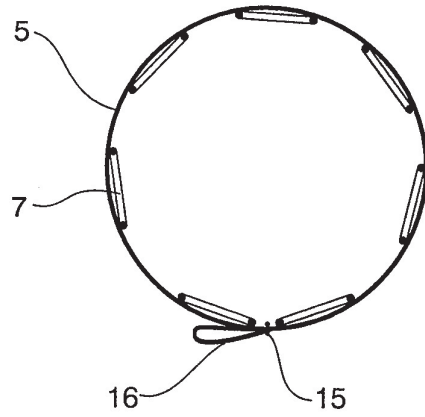

FIG 4

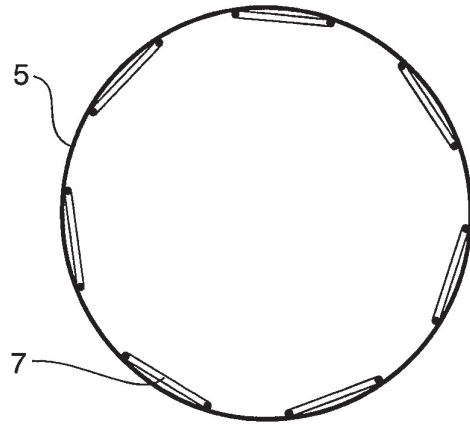

FIG 5

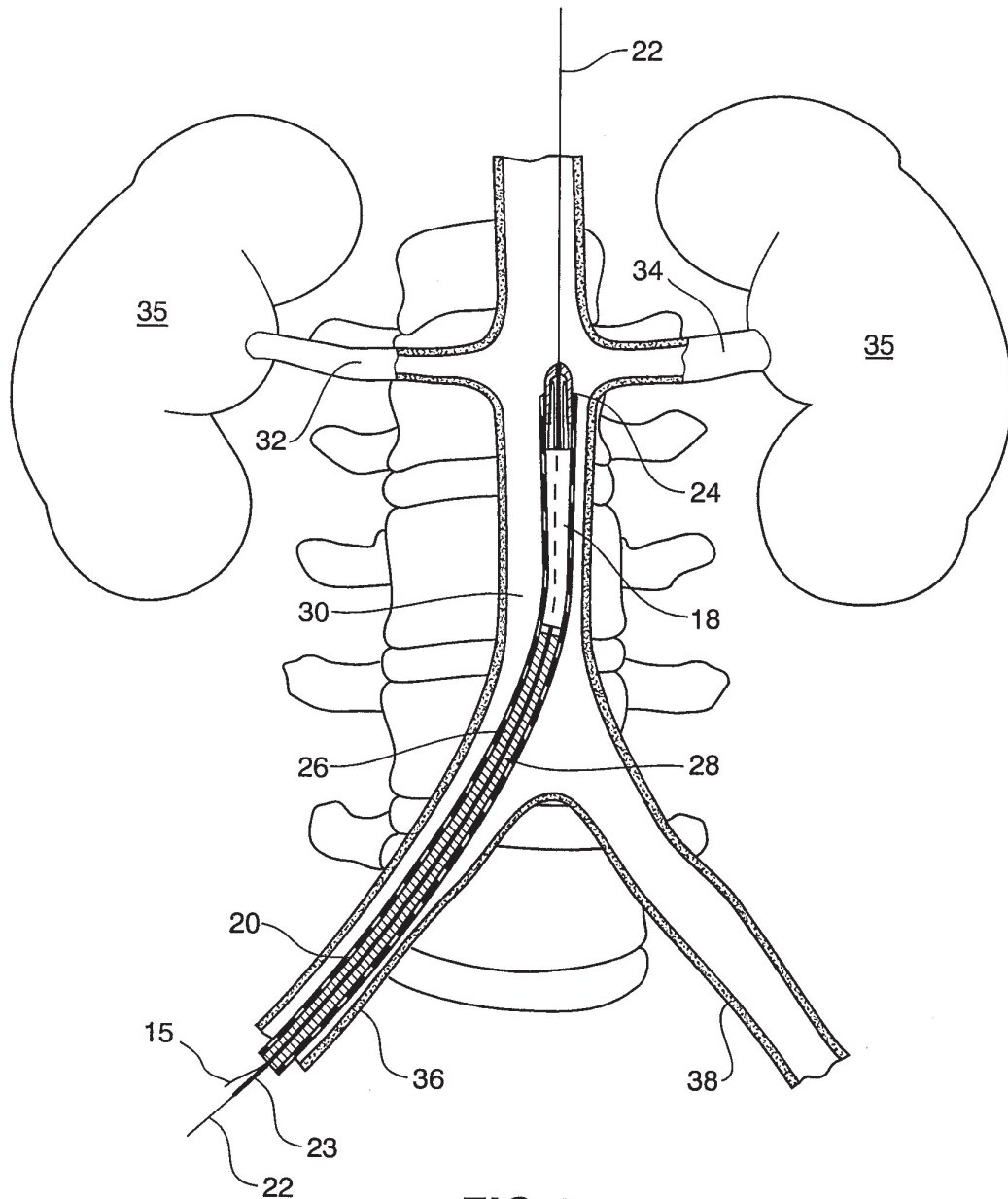

FIG 6

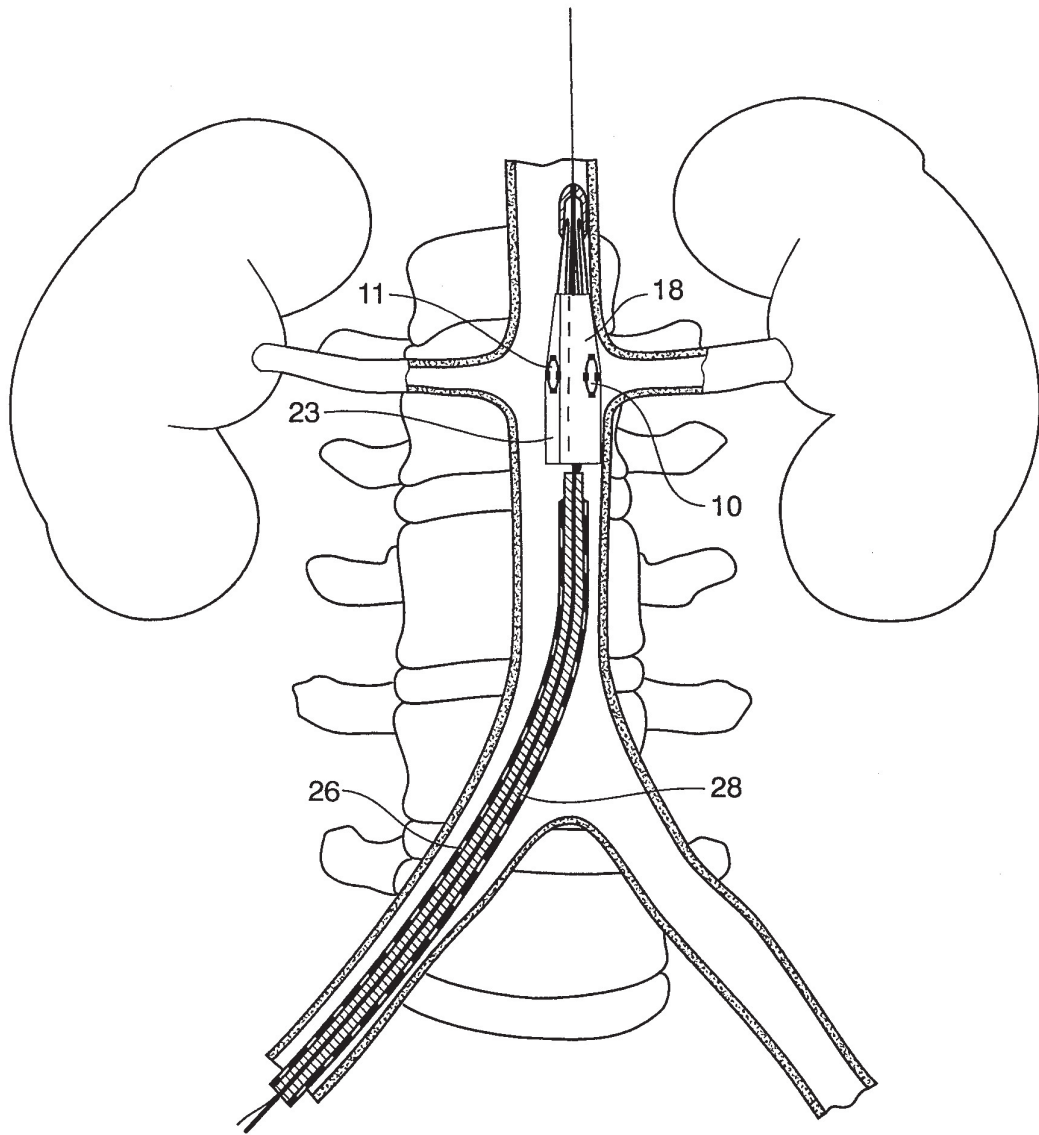

FIG 7

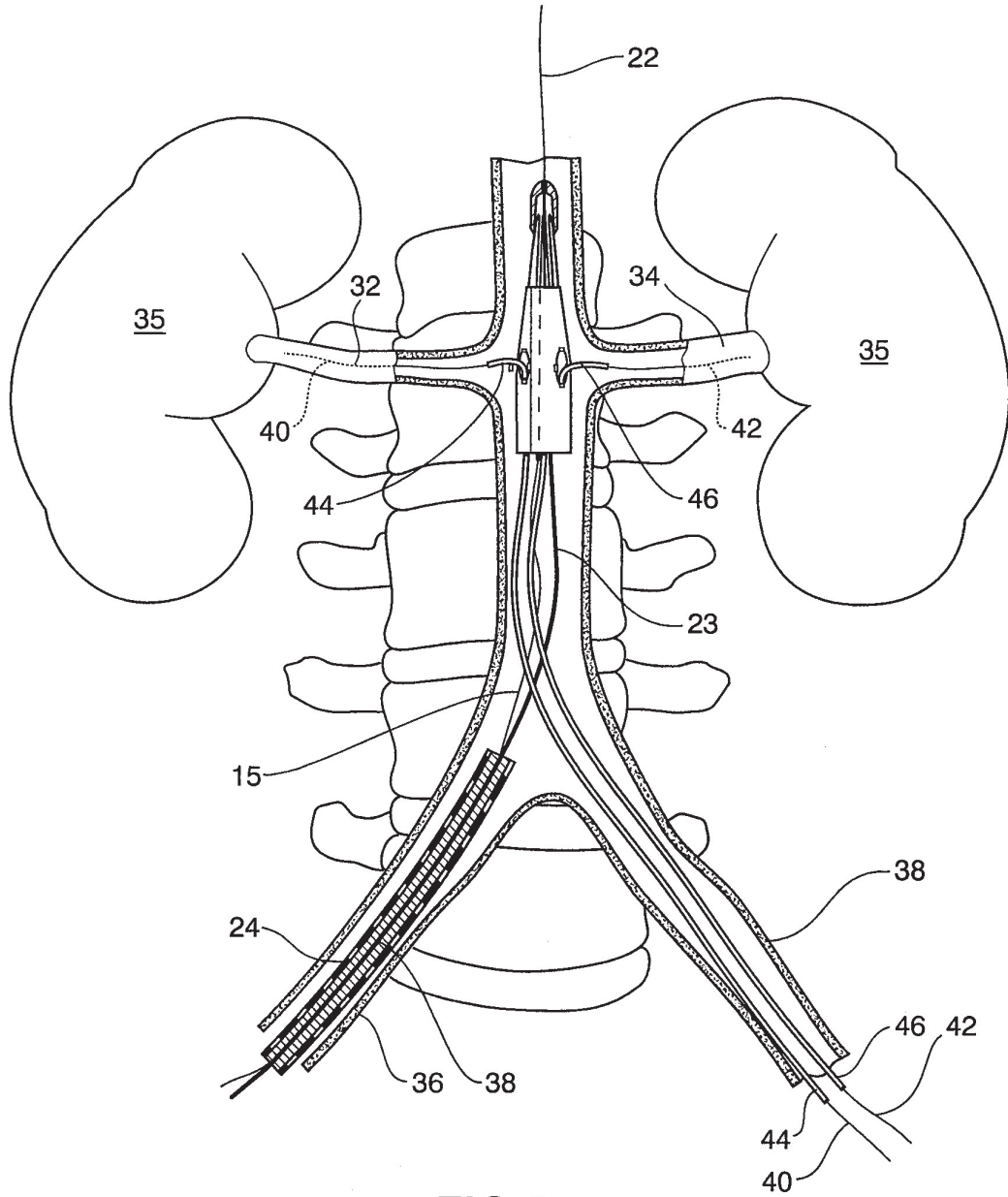

FIG 8

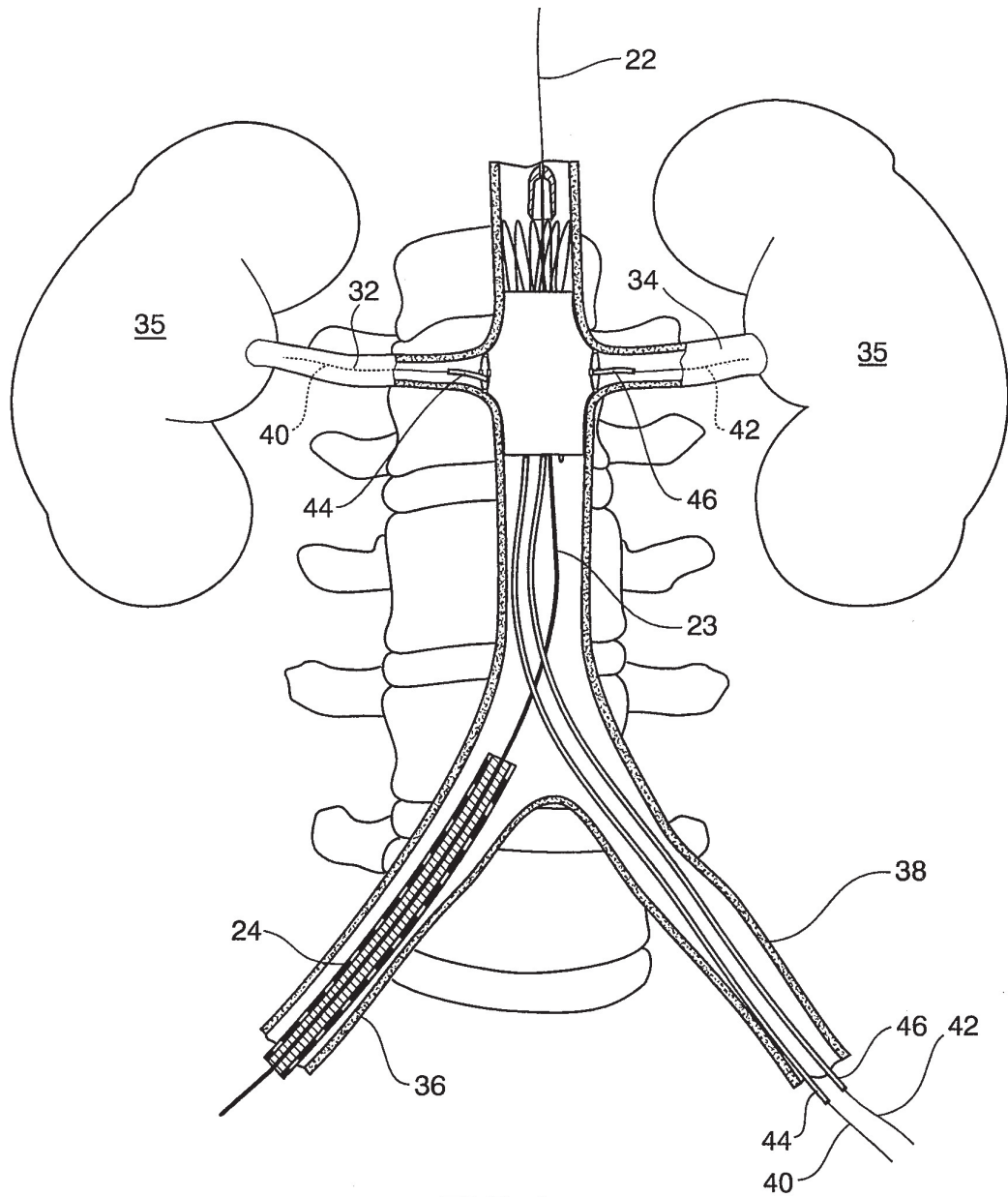

FIG 9

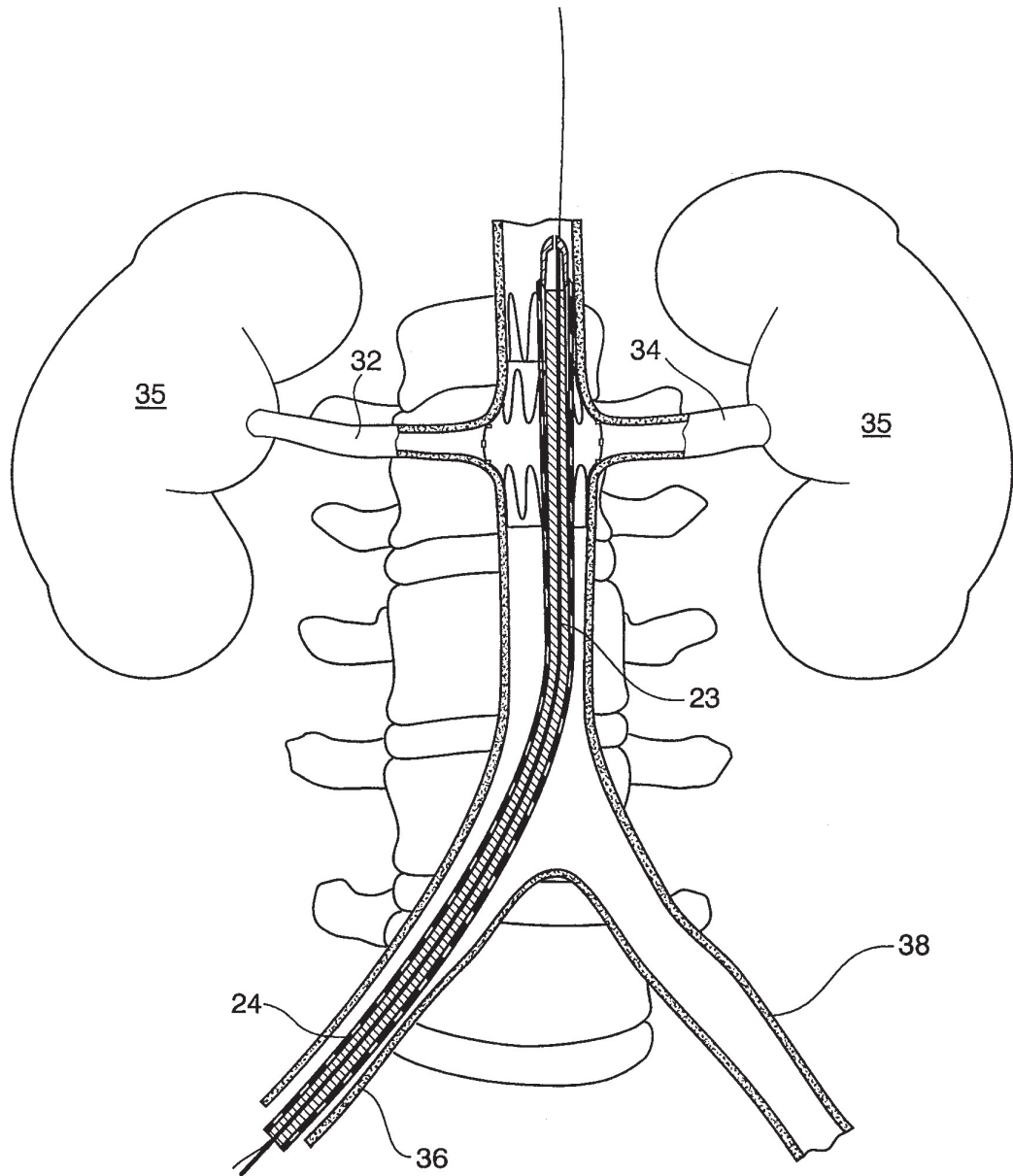

FIG 10

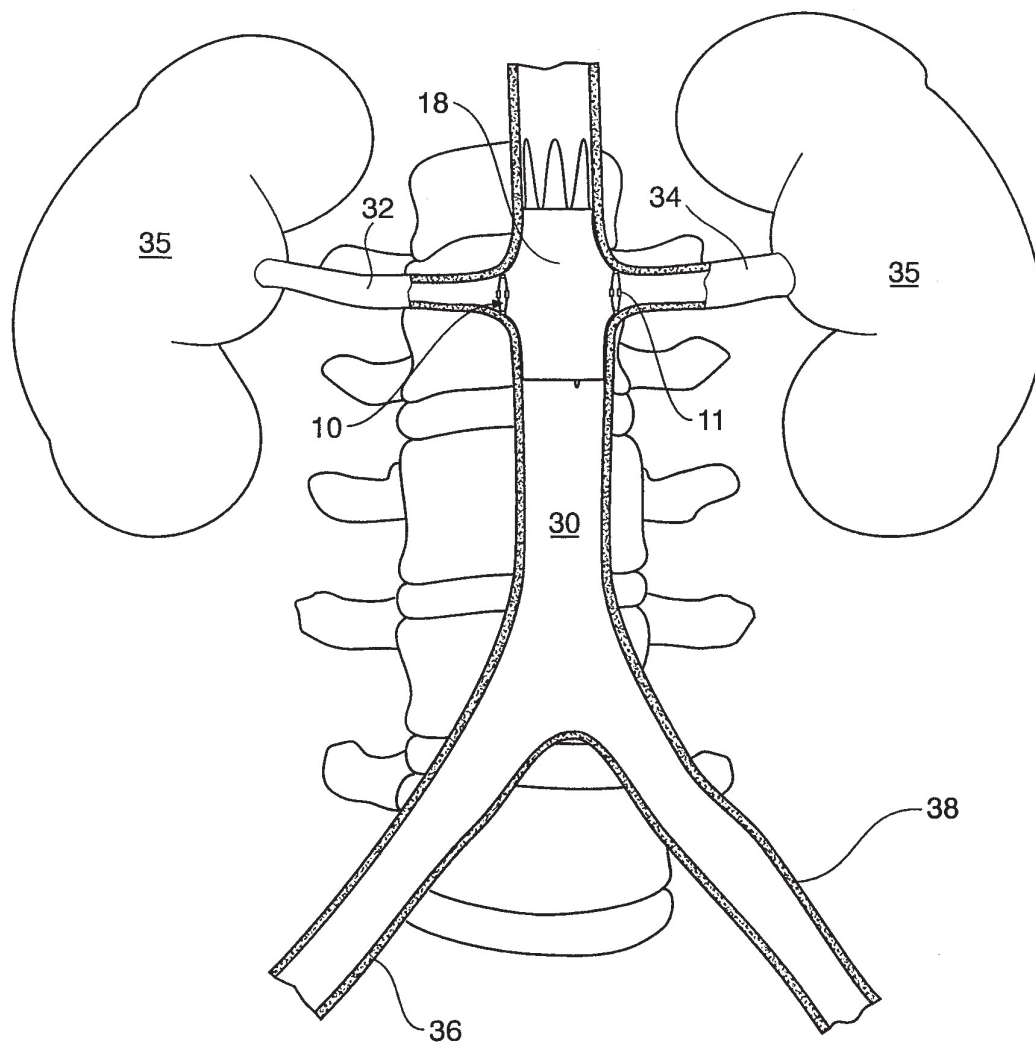
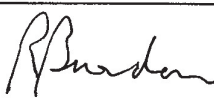

FIG 11

INTERNATIONAL SEARCH REPORT

International application No.
PCT/AU 98/01019

A. CLASSIFICATION OF SUBJECT MATTER		
Int Cl ⁶ : A61F 2/06		
According to International Patent Classification (IPC) or to both national classification and IPC		
B. FIELDS SEARCHED		
Minimum documentation searched (classification system followed by classification symbols) IC ⁶ A61F 2/- A61M 29/-		
Documentation searched other than minimum documentation to the extent that such documents are included in the fields searched		
Electronic data base consulted during the international search (name of data base and, where practicable, search terms used) WPAT & JAPIO with junct: intersect: branch: aort: arter: vessel stent# z-stent#		
C. DOCUMENTS CONSIDERED TO BE RELEVANT		
Category*	Citation of document, with indication, where appropriate, of the relevant passages	Relevant to claim No.
A	WO, A, 98/36709 (SCIMED LIFE SYSTEMS INC) 27 August 1998	
A	WO, A, 97/45073 (BARD GALWAY LIMITED) 4 December 1997	
A	US, A, 5617878 (TAHERI) 8 April 1997	
<input checked="" type="checkbox"/> Further documents are listed in the continuation of Box C <input checked="" type="checkbox"/> See patent family annex		
* Special categories of cited documents: "A" document defining the general state of the art which is not considered to be of particular relevance "E" earlier application or patent but published on or after the international filing date "L" document which may throw doubts on priority claim(s) or which is cited to establish the publication date of another citation or other special reason (as specified) "O" document referring to an oral disclosure, use, exhibition or other means "P" document published prior to the international filing date but later than the priority date claimed	"T" later document published after the international filing date or priority date and not in conflict with the application but cited to understand the principle or theory underlying the invention "X" document of particular relevance; the claimed invention cannot be considered novel or cannot be considered to involve an inventive step when the document is taken alone "Y" document of particular relevance; the claimed invention cannot be considered to involve an inventive step when the document is combined with one or more other such documents, such combination being obvious to a person skilled in the art "&" document member of the same patent family	
Date of the actual completion of the international search 8 February 1999		Date of mailing of the international search report 11 FEB 1999
Name and mailing address of the ISA/AU AUSTRALIAN PATENT OFFICE PO BOX 200 WODEN ACT 2606 AUSTRALIA Facsimile No.: (02) 6285 3929		Authorised officer  ROSS BURDON Telephone No.: (02) 6283 2605

INTERNATIONAL SEARCH REPORT

International application No.
PCT/AU 98/01019

C (Continuation). DOCUMENTS CONSIDERED TO BE RELEVANT		
Category*	Citation of document, with indication, where appropriate, of the relevant passages	Relevant to claim No.
A	WO, A, 95/16406 (WILLIAM COOK EUROPE) 22 June 1995	

INTERNATIONAL SEARCH REPORT
Information on patent family members

International application No.
PCT/AU 98/01019

This Annex lists the known "A" publication level patent family members relating to the patent documents cited in the above-mentioned international search report. The Australian Patent Office is in no way liable for these particulars which are merely given for the purpose of information.

Patent Document Cited in Search Report		Patent Family Member					
WO	98/36709	AU	66657/98				
WO	97/45073	AU	27855/97	EP	844853	IT	96130294
WO	95/16406	AU	12719/94	CZ	9601728	EP	734235
		PL	315028	US	5562724		

END OF ANNEX