

Extended output voltage adjustment (0 V to 3.5 V) using the TI TPS5210

By Bang Sup Lee

Application Specialist, Power Management

This application note describes the design of a 12-V input/0-V to 1.3-V output synchronous buck regulator using the TI TPS5210 programmable controller. Although the output voltage can be extended down to 0 V to 1.3 V using the auxiliary circuitry described in this note, the supply will still be capable of providing an output voltage range from 1.3 V to 3.5 V, determined by the voltage identification code (VID).

The TPS5210, a synchronous buck regulator controller, provides an accurate, programmable supply voltage suitable for microprocessor power applications that require fast response to rapidly changing loads and precise voltage regulation.

A simplified diagram of the regulator circuit is shown in Figure 1. The diagram shows the 1% voltage reference, hysteresis control and gate drivers with adaptive dead-time control. The reference voltage ranging from 1.3 V to 3.5 V is determined by the VID. The hysteresis controller senses the output voltage through the feedback loop (V_{SENSE} pin) and the supply regulates the DC voltage level to the reference value (V_{REF}) set using the data on the VID pins. When the feedback voltage V_{SENSE} is rescaled to a specific value, the regulator output voltage can be extended to 0 V to 1.3 V.

Figure 2 shows the application circuit of the extended 1-V output, which is identical to the application shown in

Figure 1. Synchronous buck regulator using the TPS5210

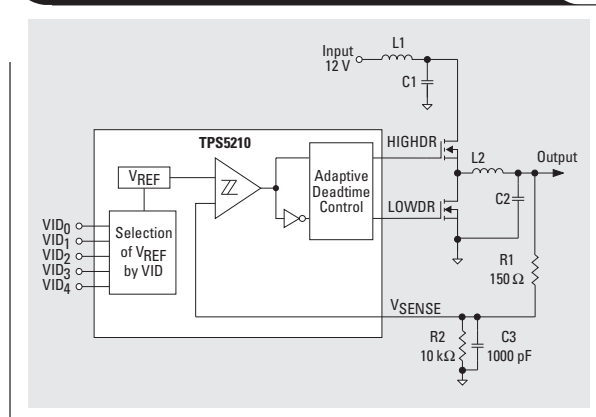
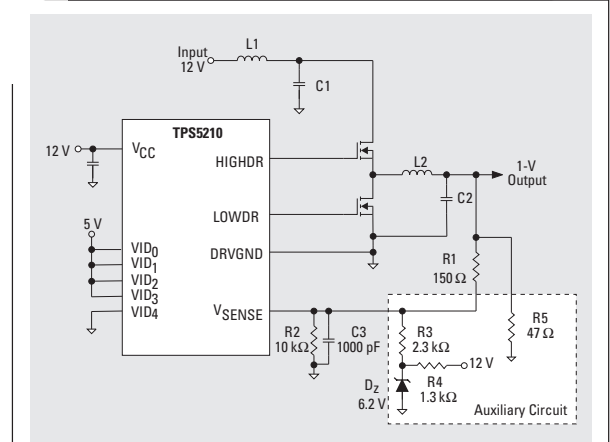

Figure 2. 1-V regulator using the TPS5210



Adding a few inexpensive components in the feedback path of TPS5210 enables the generation of 0-V to 1.3-V regulated.

Figure 1 (TPS5210 data sheet, literature number SLVS171A, Figure 18), except for the auxiliary circuit.

To operate the circuit for a 1-V output, the voltage reference (V_{REF}) should be set to 1.3 V using the VID code. The internal hysteresis comparator in the TPS5210 regulates the output voltage to 1.3 V, comparing V_{REF} (1.3 V) with the output feedback voltage, V_{SENSE} . Since the output voltage feedback signal (V_{SENSE}) is scaled to 1.3/1.0 V (V_{SENSE}/V_{OUT}) by using a resistive voltage divider (R1-R3) as shown in Figure 2, the output voltage is regulated at 1 V. The demand resistor (R3) value required for a 1-V output is calculated using Equation 1.

$$R3 = \frac{V_{DZ} - V_{SENSE}}{\frac{V_{SENSE} - V_{OUT}}{R1} + \frac{V_{SENSE}}{R2}} = \frac{6.2 - 1.3}{\frac{1.3 - 1.0}{150} + \frac{1.3}{10k}} = 2.3 \text{ k}\Omega \quad (1)$$

This method can also be applied to any output voltage ranging between 0 V to 1.3 V by using the above equation.

IMPORTANT NOTICE

Texas Instruments Incorporated and its subsidiaries (TI) reserve the right to make corrections, modifications, enhancements, improvements, and other changes to its products and services at any time and to discontinue any product or service without notice. Customers should obtain the latest relevant information before placing orders and should verify that such information is current and complete. All products are sold subject to TI's terms and conditions of sale supplied at the time of order acknowledgment.

TI warrants performance of its hardware products to the specifications applicable at the time of sale in accordance with TI's standard warranty. Testing and other quality control techniques are used to the extent TI deems necessary to support this warranty. Except where mandated by government requirements, testing of all parameters of each product is not necessarily performed.

TI assumes no liability for applications assistance or customer product design. Customers are responsible for their products and applications using TI components. To minimize the risks associated with customer products and applications, customers should provide adequate design and operating safeguards.

TI does not warrant or represent that any license, either express or implied, is granted under any TI patent right, copyright, mask work right, or other TI intellectual property right relating to any combination, machine, or process in which TI products or services are used. Information published by TI regarding third-party products or services does not constitute a license from TI to use such products or services or a warranty or endorsement thereof. Use of such information may require a license from a third party under the patents or other intellectual property of the third party, or a license from TI under the patents or other intellectual property of TI.

Reproduction of information in TI data books or data sheets is permissible only if reproduction is without alteration and is accompanied by all associated warranties, conditions, limitations, and notices. Reproduction of this information with alteration is an unfair and deceptive business practice. TI is not responsible or liable for such altered documentation.

Resale of TI products or services with statements different from or beyond the parameters stated by TI for that product or service voids all express and any implied warranties for the associated TI product or service and is an unfair and deceptive business practice. TI is not responsible or liable for any such statements.

Following are URLs where you can obtain information on other Texas Instruments products and application solutions:

Products

Amplifiers	amplifier.ti.com
Data Converters	dataconverter.ti.com
DSP	dsp.ti.com
Interface	interface.ti.com
Logic	logic.ti.com
Power Mgmt	power.ti.com
Microcontrollers	microcontroller.ti.com

Applications

Audio	www.ti.com/audio
Automotive	www.ti.com/automotive
Broadband	www.ti.com/broadband
Digital control	www.ti.com/digitalcontrol
Military	www.ti.com/military
Optical Networking	www.ti.com/opticalnetwork
Security	www.ti.com/security
Telephony	www.ti.com/telephony
Video & Imaging	www.ti.com/video

TI Worldwide Technical Support

Internet

TI Semiconductor Product Information Center Home Page
support.ti.com

TI Semiconductor KnowledgeBase Home Page
support.ti.com/sc/knowledgebase

Product Information Centers

Americas

Phone	+1(972) 644-5580	Fax	+1(972) 927-6377
Internet/Email	support.ti.com/sc/pic/americas.htm		

Europe, Middle East, and Africa

Phone			
Belgium (English)	+32 (0) 27 45 54 32	Netherlands (English)	+31 (0) 546 87 95 45
Finland (English)	+358 (0) 9 25173948	Russia	+7 (0) 95 7850415
France	+33 (0) 1 30 70 11 64	Spain	+34 902 35 40 28
Germany	+49 (0) 8161 80 33 11	Sweden (English)	+46 (0) 8587 555 22
Israel (English)	1800 949 0107	United Kingdom	+44 (0) 1604 66 33 99
Italy	800 79 11 37		
Fax	+(49) (0) 8161 80 2045		
Internet	support.ti.com/sc/pic/euro.htm		

Japan

Fax			
International	+81-3-3344-5317	Domestic	0120-81-0036
Internet/Email	support.ti.com/sc/pic/japan.htm		
International	www.tij.co.jp/pic		
Domestic			

Asia

Phone			
International	+886-2-23786800		
Domestic	Toll-Free Number		Toll-Free Number
Australia	1-800-999-084	New Zealand	0800-446-934
China	800-820-8682	Philippines	1-800-765-7404
Hong Kong	800-96-5941	Singapore	800-886-1028
Indonesia	001-803-8861-1006	Taiwan	0800-006800
Korea	080-551-2804	Thailand	001-800-886-0010
Malaysia	1-800-80-3973		
Fax	886-2-2378-6808	Email	tiasia@ti.com
Internet	support.ti.com/sc/pic/asia.htm		ti-china@ti.com

C011905

Safe Harbor Statement: This publication may contain forward-looking statements that involve a number of risks and uncertainties. These "forward-looking statements" are intended to qualify for the safe harbor from liability established by the Private Securities Litigation Reform Act of 1995. These forward-looking statements generally can be identified by phrases such as TI or its management "believes," "expects," "anticipates," "foresees," "forecasts," "estimates" or other words or phrases of similar import. Similarly, such statements herein that describe the company's products, business strategy, outlook, objectives, plans, intentions or goals also are forward-looking statements. All such forward-looking statements are subject to certain risks and uncertainties that could cause actual results to differ materially from those in forward-looking statements. Please refer to TI's most recent Form 10-K for more information on the risks and uncertainties that could materially affect future results of operations. We disclaim any intention or obligation to update any forward-looking statements as a result of developments occurring after the date of this publication.

Trademarks: All trademarks are the property of their respective owners.

Mailing Address: Texas Instruments
Post Office Box 655303
Dallas, Texas 75265

© 2005 Texas Instruments Incorporated