



US005898235A

# United States Patent [19]

[11] **Patent Number:** 5,898,235

McClure

[45] **Date of Patent:** Apr. 27, 1999

[54] **INTEGRATED CIRCUIT WITH POWER DISSIPATION CONTROL** 5,167,024 11/1992 Smith et al. .... 364/273.1  
 5,483,464 1/1996 Song ..... 307/64  
 5,513,361 4/1996 Young ..... 395/750.03

[75] Inventor: **David C. McClure**, Carrollton, Tex.

[73] Assignee: **STMicroelectronics, Inc.**, Carrollton, Tex.

*Primary Examiner*—Albert W. Paladini  
*Attorney, Agent, or Firm*—Theodore E. Galanthay; Lisa K. Jorgenson; Peter J. Thoma

[21] Appl. No.: **08/775,611**

[22] Filed: **Dec. 31, 1996**

[57] **ABSTRACT**

[51] **Int. Cl.**<sup>6</sup> ..... **H03K 5/153**

[52] **U.S. Cl.** ..... **307/64; 327/544; 365/227; 395/750.03; 364/707**

[58] **Field of Search** ..... 307/64, 66; 327/544; 365/227; 395/750.03; 364/273–273.5, 707

An integrated circuit device such as an SRAM operating in a battery backup mode, or operating in a quiescent mode when deselected in the operation of a portable electronic device, includes a power dissipation control circuit that reduces the voltage on an internal power supply node so that the memory array is powered at a minimum level sufficient to retain the data stored therein intact.

[56] **References Cited**

U.S. PATENT DOCUMENTS

4,683,382 7/1987 Sakurai ..... 365/227

**19 Claims, 2 Drawing Sheets**

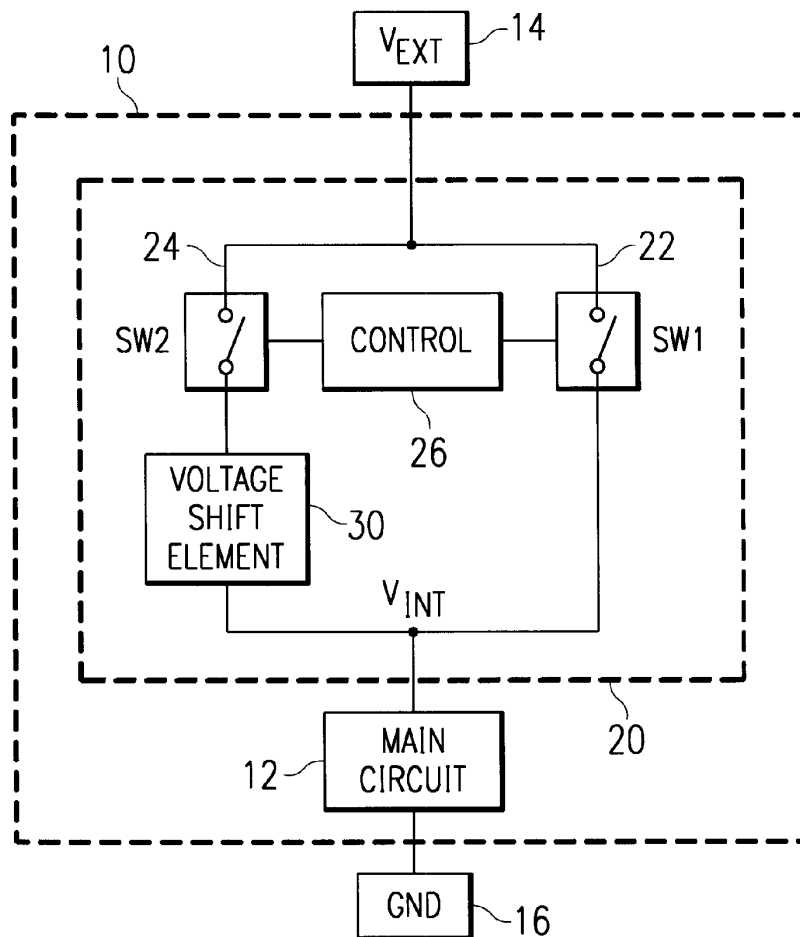

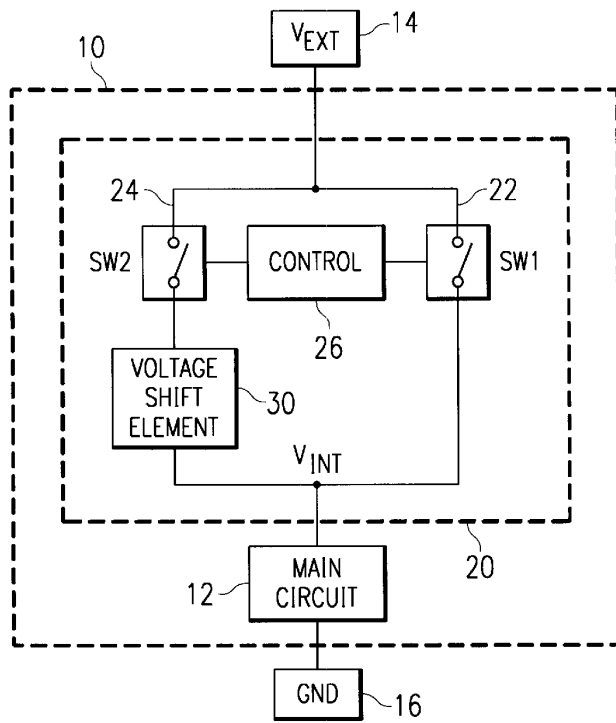

FIG. 1

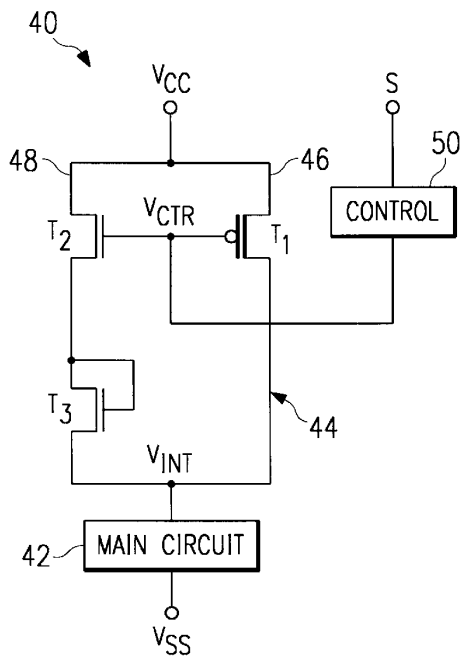

FIG. 2

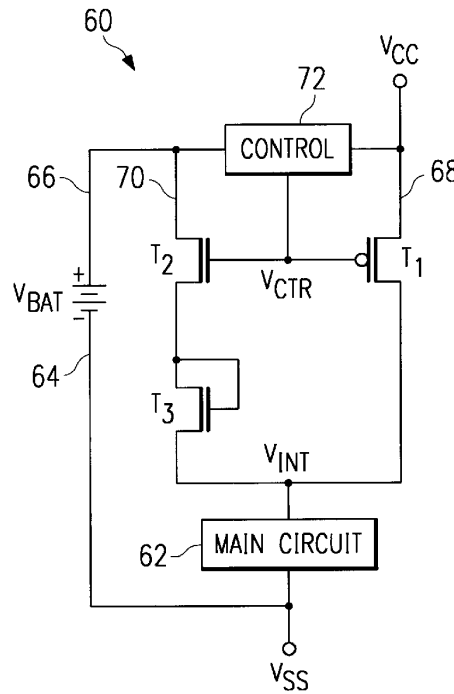

FIG. 3

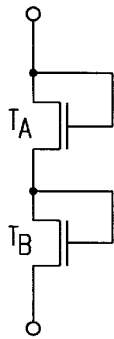

FIG. 4



FIG. 5

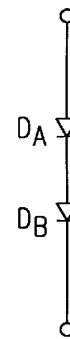

FIG. 6

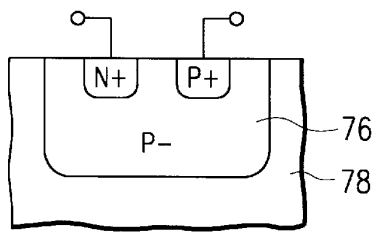

FIG. 7

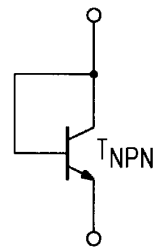

FIG. 8

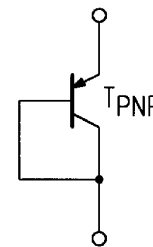

FIG. 9

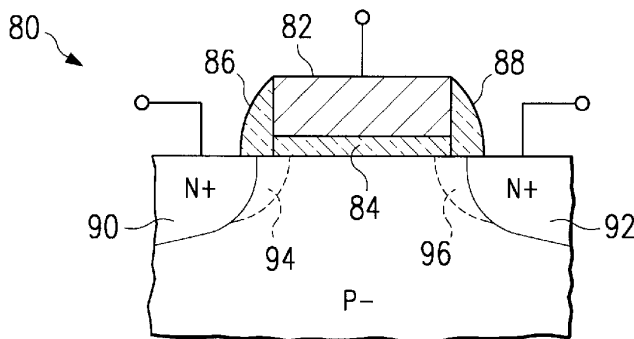

FIG. 10

## INTEGRATED CIRCUIT WITH POWER DISSIPATION CONTROL

### BACKGROUND OF THE INVENTION

The present invention relates to integrated circuit devices and more particularly to battery-powered integrated circuits with low power consumption.

Many integrated circuits, such as static random access memory ("SRAM") devices, rely on batteries as backup power supplies to retain the data stored within them while the equipment in which they are used is turned off or the power supply to the equipment has failed. Such integrated circuits are becoming more complex, thus placing greater demands on such backup batteries. Although battery technology is improving, increases in battery capabilities are not keeping up with the increasing power requirements of the integrated circuit devices they serve. There is, accordingly, a need to reduce the power consumption of integrated circuits when used in a battery backup mode.

Additionally, portable electronic devices (computers, cellular phones, etc.) rely upon batteries to supply operational power during general use. Such devices employ integrated circuit devices, which contribute to battery power consumption and reduced operating time between battery rechargings. There is, accordingly, a need to reduce the power consumption of integrated circuits used in portable electronic devices in order to extend the time of operation on a single charge of the battery.

### SUMMARY OF THE INVENTION

In accordance with the principal object of the present invention, a power dissipation control circuit is included in an integrated circuit device for switching the power supplied to a main circuit of the device from full power to a reduced power depending on the mode of operation of the main circuit.

Another object of the invention is to switch an integrated circuit memory device to a low-power dissipation mode when the device is deselected by external circuitry so that the device merely needs to maintain the status of the stored information without performing input/output operations.

Another object of the invention is to switch an integrated circuit memory device to a low-power dissipation mode during battery backup operation so that a minimum holding voltage is applied to the device in order to maintain the data stored therein for an extended duration.

### BRIEF DESCRIPTION OF THE DRAWINGS

Other objects, features and advantages of the invention will be best understood from the following detailed description, read in conjunction with the accompanying drawings, in which:

FIG. 1 is a generalized circuit diagram of a device of the present invention;

FIG. 2 is a circuit diagram of one implementation of the present invention;

FIG. 3 is a circuit diagram of another implementation of the present invention;

FIG. 4 is one embodiment of a subcircuit of the present invention;

FIG. 5 is another embodiment of a subcircuit of the present invention;

FIG. 6 is another embodiment of a subcircuit of the present invention;

FIG. 7 is a cross-section of a PN junction diode used in the subcircuit of FIG. 6;

FIG. 8 is another embodiment of a subcircuit of the present invention;

FIG. 9 is another embodiment of a subcircuit of the present invention; and

FIG. 10 is cross-section of a transistor specially fabricated to provide a relatively high threshold voltage, which may be useful in another embodiment of the present invention.

### DETAILED DESCRIPTION OF THE INVENTION

Referring to FIG. 1, an integrated circuit device in accordance with the present invention is indicated by reference numeral **10**, designating the circuitry contained within the larger dashed outline. The integrated circuit device **10** includes a main circuit **12**, which is preferably a memory circuit such as an SRAM memory array. Conventional SRAMs include so-called "4T" and "6T" types, both being well known in the art. The 4T type SRAM uses four N-channel MOSFETs, (metal-oxide-semiconductor field effect transistors) and two resistors for each memory cell of the memory array. The resistors are typically high resistivity portions of polycrystalline silicon (polysilicon) lines running within the array. The 6T type SRAM uses six MOSFETs, two of which are P-channel transistors and four of which are N-channel transistors.

The integrated circuit device **10** is connected between a high voltage terminal **14** and a low voltage terminal **16**, which are respectively labeled the  $V_{EXT}$  (indicating an external voltage supply) and GND (indicating a ground terminal). Integrated circuit device **10** includes a power dissipation control circuit contained within the smaller dashed outline labeled by reference numeral **20**. The power dissipation control circuit **20** has a first power supply leg **22** connected in parallel with a second power supply leg **24**. A first switch **SW1** is disposed in the first leg **22** and a second switch **SW2** is disposed in the second leg **24**. A voltage shift element **30** is also disposed in the second leg **24** in series with the second switch **SW2**.

The first and second legs **22** and **24** provide alternative paths between the high voltage terminal **14** and an internal power supply node labeled  $V_{INT}$ . The main circuit **12** is connected between the internal power supply node  $V_{INT}$  and the low voltage or GND terminal **16**. The states of the switches **SW1** and **SW2** are controlled by control circuitry **26**. When the main circuit **12** is in an active mode, which for an SRAM memory array consists of reading data in from external circuitry or writing data out to external circuitry, the main circuit **12** requires full power at a normal operating voltage level. However, when the main circuit is in a quiescent mode, which in the case of an SRAM memory means merely maintaining the status of the data stored therein, it does not need full power at the normal operating voltage level. Instead, in the quiescent mode, it can maintain the status of the information stored in the memory array by applying a minimum voltage necessary to maintain a transistor in each memory cell array turned on. Such minimum voltage, or "holding" voltage, may be only a few tenths of a volt above the threshold voltage of a typical transistor used in each memory cell of the array.

For example, a typical memory cell transistor requires only about 0.6 volts to be maintained on. Some processes differentiate the doping used for making N-channel and P-channel transistors so that the N-channel transistor may require 0.6 volts to be maintained on, whereas the P-channel

transistor may require about 0.8 volts to be maintained on. Thus, for a 4T type SRAM using all N-channel transistors, a holding voltage of about 1.0 volt applied to the internal power supply node  $V_{INT}$  is sufficient to maintain the data stored in the memory array. For a 6T type SRAM memory, which uses both P-channel and N-channel transistors, a holding voltage of about 1.2 volts is sufficient to maintain the data stored in the memory array.

Accordingly, it will be appreciated that applying the full normal operating voltage to the memory array unnecessarily causes excessive power dissipation when the memory array is operating in the quiescent mode. Therefore, when the memory array is in the quiescent mode, the control circuitry 26 opens the first switch SW1 and closes the second switch SW2 so that power is supplied to the main circuit through the second leg 24. In the second leg 24, the voltage shift element 30 causes a voltage drop from the level of the normal operating voltage to the desired holding voltage level needed to maintain the status of the data stored in the memory array of the main circuit 12.

Referring to FIG. 2, a specific application of the invention will now be described. This application is useful for conserving battery power in a portable electronic device in which the main battery (not shown) supplies power at a normal operating voltage level designated  $V_{cc}$ . The integrated circuit device of FIG. 2 is designated generally by reference numeral 40 and includes a high voltage terminal, labeled  $V_{cc}$ , and a low voltage terminal labeled  $V_{ss}$ . The device 40 includes a main circuit 42, which may be a memory array such as an SRAM or a DRAM or may be any of various other integrated circuits having an active mode and quiescent mode.

The main circuit 42 is connected between an internal power supply node  $V_{INT}$  and the low voltage terminal  $V_{ss}$ . A power dissipation control circuit 44 is connected between the high voltage terminal  $V_{cc}$  and the internal power supply node  $V_{INT}$ . The power dissipation control circuit 44 has a first leg 46 connected in parallel with a second leg 48. The first leg 46 has a channel P-channel MOS transistor  $T_1$  connecting the high-voltage terminal  $V_{cc}$  to the internal power supply node  $V_{INT}$ . The second leg 48 has a first N-channel MOS transistor  $T_2$  connected in series with a second N-channel MOS transistor  $T_3$  in a path connecting the high voltage terminal  $V_{cc}$  to the internal power supply node  $V_{INT}$ . Transistor  $T_3$  is connected in a well-known manner with its gate connected to its drain to function like a diode.

Control circuitry 50 controls the on and off states of the transistors  $T_1$  and  $T_2$  by means of a control signal  $V_{CTR}$  applied at a common connection between the gates of transistors  $T_1$  and  $T_2$ . Thus, when transistor  $T_1$  is on, transistor  $T_2$  is off, and vice versa. Control circuitry 50 operates in response to an external signal S applied to the integrated circuit device 40. For example, incoming signal S may transmit chip select and chip deselect signals from other circuitry external to the integrated circuit device. The control circuitry 50 interprets signal S to apply  $V_{CTR}$  as a low voltage signal turning on transistor  $T_1$  and turning off transistor  $T_2$  when the integrated circuit device 40 has been selected or "enabled" by signal S for normal operation. Under such circumstances, the normal  $V_{cc}$  operating voltage is applied to the main circuit 42, with essentially no drop across transistor  $T_1$ , because it is turned on hard. When the integrated circuit device 40 has been deselected by incoming signal S, the control circuitry 50 generates control signal  $V_{CTR}$  at a high voltage level to turn off transistor  $T_1$  and turn on transistor  $T_2$ . Under these circumstances, the voltage  $V_{cc}$

is reduced by the voltage drops across transistors  $T_2$  and  $T_3$  before appearing at the internal power supply node  $V_{INT}$ . Although transistor  $T_2$  is specifically illustrated as an N-channel transistor, it could be implemented as a P-channel transistor driven by an inverted  $V_{CTR}$  signal. However, the increased voltage drop provided by the N-channel transistor  $T_2$  as shown may be preferred in the particular implementation of the invention.

Based upon the respective levels of the normal voltage supply  $V_{cc}$  and the minimum holding voltage needed at node  $V_{INT}$ , one or more additional transistors, such as transistor  $T_3$ , can be connected in series in the second leg 48. For example, referring briefly to FIG. 4, two N-channel transistors  $T_A$  and  $T_B$  are shown connected in series and each with its gate connected to its drain to provide double the voltage drop of the single transistor  $T_3$  in FIG. 2. Accordingly, the voltage drop in the second leg 48 of the power dissipation control circuit 44 can be adjusted appropriately to reduce the voltage level down from  $V_{cc}$  to approximately the minimum holding voltage necessary for maintaining the condition of the main circuit 42 in its quiescent state. It will be appreciated that this application of the inventive circuit will extend the operating time of a battery-operated portable electronic device by reducing the power dissipation of integrated circuit devices such as SRAM memory devices when they are deselected and are merely maintaining data in a quiescent state.

Now referring to FIG. 3, another implementation of the inventive circuit will be described in the context of a battery backed-up SRAM. FIG. 3 shows an integrated circuit device designated generally by a reference numeral 60. The integrated circuit device 60 includes a main circuit 62, which in this case is an SRAM memory array. It may be either a 4T type or a 6T type SRAM as previously described.

The main circuit 62 is normally powered by a conventional external power supply (not shown) connected at a high voltage terminal  $V_{cc}$  and a low voltage terminal  $V_{ss}$ . A backup battery  $V_{BAT}$  is connected to provide a source of power to the main circuit 62 when the external power supply fails. Typically, such a backup battery is a small battery attached directly to the housing (not shown) of the integrated circuit device 60.

The backup battery  $V_{BAT}$  has a negative terminal 64 and a positive terminal 66. The negative terminal 64 is connected to the low voltage terminal  $V_{ss}$ . The main circuit 62 is connected between an internal power supply node  $V_{INT}$  and the low voltage terminal  $V_{ss}$ . A first power supply leg 68 connects the high voltage terminal  $V_{cc}$  to the internal power supply node  $V_{INT}$  through a P-channel MOS transistor  $T_1$ . A second power supply leg 70 connects the positive terminal 66 of the backup battery  $V_{BAT}$  to the internal power supply node  $V_{INT}$  through series-connected N-channel transistors  $T_2$  and  $T_3$ .

Control circuitry 72 connected to the high voltage terminal  $V_{cc}$  and the positive terminal 66 of the backup battery  $V_{BAT}$  determines whether power will be supplied to the main circuit 62 through the first leg 68 or the second leg 70. The gates of transistors  $T_1$  and  $T_2$  are connected together at a node that receives a control signal  $V_{CTR}$  generated by the control circuitry 72. The control circuitry 72 senses the level of the voltage on the high voltage terminal  $V_{cc}$  and compares it to an internally generated reference voltage that indicates whether the voltage level on the high voltage terminal  $V_{cc}$  has fallen to the level requiring backup battery operation. The control circuitry 72 generates control signal  $V_{CTR}$  at a low level (i.e., at ground or  $V_{ss}$ ) whenever the voltage level

# Explore Litigation Insights

Docket Alarm provides insights to develop a more informed litigation strategy and the peace of mind of knowing you're on top of things.

## Real-Time Litigation Alerts



Keep your litigation team up-to-date with **real-time alerts** and advanced team management tools built for the enterprise, all while greatly reducing PACER spend.

Our comprehensive service means we can handle Federal, State, and Administrative courts across the country.

## Advanced Docket Research



With over 230 million records, Docket Alarm's cloud-native docket research platform finds what other services can't. Coverage includes Federal, State, plus PTAB, TTAB, ITC and NLRB decisions, all in one place.

Identify arguments that have been successful in the past with full text, pinpoint searching. Link to case law cited within any court document via Fastcase.

## Analytics At Your Fingertips



Learn what happened the last time a particular judge, opposing counsel or company faced cases similar to yours.

Advanced out-of-the-box PTAB and TTAB analytics are always at your fingertips.

## API

Docket Alarm offers a powerful API (application programming interface) to developers that want to integrate case filings into their apps.

## LAW FIRMS

Build custom dashboards for your attorneys and clients with live data direct from the court.

Automate many repetitive legal tasks like conflict checks, document management, and marketing.

## FINANCIAL INSTITUTIONS

Litigation and bankruptcy checks for companies and debtors.

## E-DISCOVERY AND LEGAL VENDORS

Sync your system to PACER to automate legal marketing.