



US010707057B2

(12) **United States Patent**  
**Bhutta et al.**

(10) **Patent No.:** **US 10,707,057 B2**  
(45) **Date of Patent:** **\*Jul. 7, 2020**

(54) **RF IMPEDANCE MATCHING CIRCUIT AND SYSTEMS AND METHODS INCORPORATING SAME**

(56) **References Cited**

U.S. PATENT DOCUMENTS

(71) Applicant: **Reno Technologies, Inc.**, Wilmington, DE (US)

3,641,451 A 2/1972 Hollingsworth et al.  
3,681,662 A 8/1972 Spescha  
(Continued)

(72) Inventors: **Imran Ahmed Bhutta**, Moorestown, NJ (US); **Michael Gilliam Ulrich**, Delran, NJ (US)

FOREIGN PATENT DOCUMENTS

(73) Assignee: **RENO TECHNOLOGIES, INC.**, Wilmington, DE (US)

CN 102297538 12/2011  
CN 103629851 12/2011  
(Continued)

(\* ) Notice: Subject to any disclaimer, the term of this patent is extended or adjusted under 35 U.S.C. 154(b) by 0 days.  
  
This patent is subject to a terminal disclaimer.

OTHER PUBLICATIONS

Han, Yufeng, et al., "Power accuracy and source-pull effect for a high-power RF generator". 67th ARTFG Conference, 2006, pp. 81-92.

(Continued)

(21) Appl. No.: **16/665,778**

(22) Filed: **Oct. 28, 2019**

*Primary Examiner* — Don P Le

(74) *Attorney, Agent, or Firm* — The Belles Group, P.C.

(65) **Prior Publication Data**

US 2020/0058471 A1 Feb. 20, 2020

**Related U.S. Application Data**

(63) Continuation of application No. 16/111,776, filed on Aug. 24, 2018, now Pat. No. 10,460,912, which is a (Continued)

(57) **ABSTRACT**

In one embodiment, an RF impedance matching circuit is disclosed. The matching circuit is coupled between a plasma chamber and an RF source providing an RF signal having a frequency. The matching circuit includes a first electronically variable capacitor having a first variable capacitance and a second electronically variable capacitor having a second variable capacitance. A control circuit determines a first parameter related to the plasma chamber, and then determines, based on the first parameter, a first capacitance value for the first electronically variable capacitor and a second capacitance value for the second electronically variable capacitor. The control circuit then generates a control signal to alter the first variable capacitance and the second variable capacitance accordingly, causing the RF power reflected back to the RF source to decrease while the frequency of the RF source is not altered.

(51) **Int. Cl.**  
**H01J 37/32** (2006.01)  
**H03H 11/28** (2006.01)  
(Continued)

(52) **U.S. Cl.**  
CPC ..... **H01J 37/32183** (2013.01); **H01G 7/00** (2013.01); **H01J 37/32935** (2013.01);  
(Continued)

(58) **Field of Classification Search**  
CPC ..... H01J 37/32183; H01J 37/32935; H01J 2237/334; H01J 2237/327;  
(Continued)

**17 Claims, 31 Drawing Sheets**

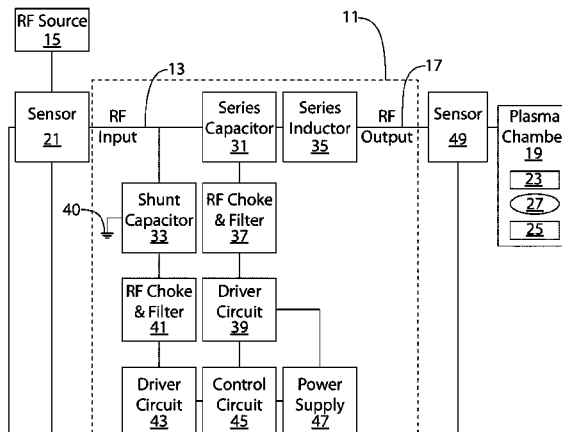

**Related U.S. Application Data**

continuation of application No. 15/637,271, filed on Jun. 29, 2017, now Pat. No. 10,431,428, which is a continuation-in-part of application No. 15/467,667, filed on Mar. 23, 2017, now Pat. No. 10,455,729, which is a continuation-in-part of application No. 14/982,244, filed on Dec. 29, 2015, now Pat. No. 10,454,453, which is a continuation-in-part of application No. 14/935,859, filed on Nov. 9, 2015, now abandoned, which is a continuation-in-part of application No. 14/622,879, filed on Feb. 15, 2015, now abandoned, which is a continuation-in-part of application No. 14/616,884, filed on Feb. 9, 2015, now Pat. No. 9,865,432, which is a continuation-in-part of application No. 14/594,262, filed on Jan. 12, 2015, now Pat. No. 9,496,122, said application No. 15/637,271 is a continuation-in-part of application No. 15/223,984, filed on Jul. 29, 2016, now Pat. No. 9,728,378, which is a continuation-in-part of application No. 15/061,020, filed on Mar. 4, 2016, now Pat. No. 9,543,122, which is a continuation-in-part of application No. 14/700,209, filed on Apr. 30, 2015, now Pat. No. 9,345,122, said application No. 15/637,271 is a continuation-in-part of application No. 14/702,900, filed on May 4, 2015, now Pat. No. 9,745,660, and a continuation-in-part of application No. 14/788,888, filed on Jul. 1, 2015, now Pat. No. 9,697,991, which is a continuation-in-part of application No. 14/622,879, filed on Feb. 15, 2015, now abandoned, said application No. 15/637,271 is a continuation-in-part of application No. 14/936,978, filed on Nov. 10, 2015, now Pat. No. 9,844,127, which is a continuation-in-part of application No. 14/935,859, filed on Nov. 9, 2015, now abandoned, said application No. 15/637,271 is a continuation-in-part of application No. 15/450,495, filed on Mar. 6, 2017, which is a continuation-in-part of application No. 15/196,821, filed on Jun. 29, 2016.

- (60) Provisional application No. 61/925,974, filed on Jan. 10, 2014, provisional application No. 61/940,139, filed on Feb. 14, 2014, provisional application No. 61/940,165, filed on Feb. 14, 2014, provisional application No. 62/077,753, filed on Nov. 10, 2014, provisional application No. 62/097,498, filed on Dec. 29, 2014, provisional application No. 62/312,070, filed on Mar. 23, 2016, provisional application No. 61/987,718, filed on May 2, 2014, provisional application No. 61/987,725, filed on May 2, 2014, provisional application No. 62/019,591, filed on Jul. 1, 2014, provisional application No. 62/077,750, filed on Nov. 10, 2014, provisional application No. 62/185,998, filed on Jun. 29, 2015, provisional application No. 62/303,625, filed on Mar. 4, 2016.

- (51) **Int. Cl.**  
*H01G 7/00* (2006.01)  
*H01L 21/02* (2006.01)  
*H01L 21/311* (2006.01)  
*H03H 7/38* (2006.01)  
*H05K 7/20* (2006.01)  
*H01L 23/473* (2006.01)

- (52) **U.S. Cl.**  
 CPC .. *H01L 21/02274* (2013.01); *H01L 21/31116*

2237/327 (2013.01); *H01J 2237/332* (2013.01); *H01J 2237/334* (2013.01); *H01L 23/473* (2013.01)

- (58) **Field of Classification Search**  
 CPC . H01J 2237/332; H05K 7/20609; H03H 7/38; H03H 11/28; H01L 21/31116; H01L 21/02274; H01L 23/473; H01G 7/00  
 USPC ..... 315/111.21, 111, 210  
 See application file for complete search history.

(56) **References Cited**

U.S. PATENT DOCUMENTS

3,828,281 A	8/1974	Chambers
4,110,700 A	8/1978	Rosen et al.
4,193,070 A	3/1980	Oppel
4,375,051 A	2/1983	Theall
4,547,746 A	10/1985	Erickson et al.
4,679,007 A	7/1987	Reese et al.
4,692,643 A	9/1987	Tokunaga et al.
4,751,408 A	6/1988	Rembert
4,929,855 A	5/1990	Ezzeddine
5,012,123 A	4/1991	Ayasli et al.
5,079,507 A	1/1992	Ishida et al.
5,273,610 A	12/1993	Thomas, III et al.
5,285,347 A	2/1994	Fox et al.
5,394,936 A	3/1995	Budelman
5,467,013 A	11/1995	Williams et al.
5,556,549 A	9/1996	Patrick et al.
5,576,629 A	11/1996	Turner et al.
5,643,364 A	7/1997	Zhao
5,654,679 A	8/1997	Mavretic et al.
5,770,922 A	6/1998	Gerrish et al.
5,815,047 A	9/1998	Sorensen et al.
5,849,136 A	12/1998	Mintz et al.
5,880,921 A	3/1999	Tham et al.
5,889,252 A	3/1999	Williams et al.
5,936,481 A	8/1999	Fujii
5,971,591 A	10/1999	Vona et al.
6,027,601 A	2/2000	Hanawa
6,046,641 A	4/2000	Chawla et al.
6,069,525 A	5/2000	Sevic et al.
6,107,872 A	8/2000	Schoepe et al.
6,137,367 A	10/2000	Ezzeddine et al.
6,252,354 B1	6/2001	Collins et al.
6,332,961 B1	12/2001	Johnson et al.
6,343,478 B1	2/2002	Chang
6,400,012 B1	6/2002	Miller et al.
6,424,232 B1	7/2002	Mavretic et al.
6,449,568 B1	9/2002	Gerrish
6,583,572 B2	6/2003	Veltrop et al.
6,617,920 B2	9/2003	Staudinger et al.
6,621,372 B2	9/2003	Kondo et al.
6,657,395 B2	12/2003	Windhorn
6,677,828 B1	1/2004	Harnett et al.
6,683,496 B2	1/2004	Poggi et al.
6,703,080 B2	3/2004	Reyzelman et al.
6,791,274 B1	9/2004	Hauer et al.
6,794,951 B2	9/2004	Finley
6,818,562 B2	11/2004	Todorow et al.
6,873,114 B2	3/2005	Avoyan et al.
6,888,313 B2	5/2005	Blackburn et al.
6,888,396 B2	5/2005	Hajiriri et al.
6,946,847 B2	9/2005	Nishimori et al.
6,967,547 B2	11/2005	Pellegrini et al.
6,995,545 B2	2/2006	Tracy et al.
7,002,799 B2	2/2006	Malone et al.
7,004,107 B1	2/2006	Raoux et al.
RE39,051 E	3/2006	Harnett
7,071,786 B2	7/2006	Inoue et al.
7,095,178 B2	8/2006	Nakano et al.
7,113,761 B2	9/2006	Bickham et al.
7,122,965 B2	10/2006	Goodman
7,164,236 B2	1/2007	Mitrovic et al.

(56)

References Cited

U.S. PATENT DOCUMENTS

7,251,121 B2	7/2007	Bhutta	8,520,413 B2	8/2013	Tran et al.
7,288,987 B2	10/2007	Carichner et al.	8,536,636 B2	9/2013	Englekirk
7,298,091 B2	11/2007	Pickard et al.	8,552,665 B2	10/2013	Larson et al.
7,298,128 B2	11/2007	Bhutta	8,558,633 B2	10/2013	McKinzie, III
7,304,438 B2	12/2007	Kishinevsky	8,559,907 B2	10/2013	Burgener et al.
7,321,750 B2	1/2008	Bergveld et al.	8,564,381 B2	10/2013	McKinzie
7,332,981 B2	2/2008	Matsumo	8,569,842 B2	10/2013	Weis et al.
7,342,789 B2	3/2008	Hall et al.	8,576,010 B2	11/2013	Yanduru
7,358,802 B2	4/2008	Chen	8,576,013 B2	11/2013	Coumou
7,397,676 B2	7/2008	Lincoln et al.	8,587,321 B2	11/2013	Chen et al.
7,439,610 B2	10/2008	Weigand	8,620,236 B2	12/2013	Manssen et al.
7,480,571 B2	1/2009	Howald et al.	8,624,501 B2	1/2014	Nagerkatti et al.
7,495,524 B2	2/2009	Omae et al.	8,633,782 B2	1/2014	Nagerkatti et al.
7,498,908 B2	3/2009	Gurov	8,638,159 B2	1/2014	Ranta et al.
7,514,935 B2	4/2009	Pankratz	8,649,754 B2	2/2014	Burgener et al.
7,518,466 B2	4/2009	Sorensen et al.	8,659,335 B2	2/2014	Nagarkatti et al.
7,535,312 B2	5/2009	McKinzie, III	8,674,606 B2	3/2014	Carter et al.
7,570,931 B2	8/2009	McCallister et al.	8,680,928 B2	3/2014	Jeon et al.
7,602,127 B2	10/2009	Coumou	8,686,796 B2	4/2014	Presti
7,642,879 B2	1/2010	Matsumo	8,710,926 B2	4/2014	Nagarkatti et al.
7,666,464 B2	2/2010	Collins et al.	8,716,984 B2	5/2014	Mueller et al.
7,701,714 B2	4/2010	Shabany	8,723,423 B2	5/2014	Hoffman et al.
7,714,676 B2	5/2010	McKinzie, III	8,742,669 B2	6/2014	Carter et al.
7,728,602 B2	6/2010	Valcore et al.	8,773,019 B2	7/2014	Coumou et al.
7,745,955 B2	6/2010	Kirchmeier et al.	8,779,859 B2	7/2014	Su et al.
7,755,300 B2	7/2010	Kishinevsky et al.	8,781,415 B1	7/2014	Coumou et al.
7,761,247 B2	7/2010	Van Zyl	8,815,329 B2	8/2014	Ilic et al.
7,764,140 B2	7/2010	Nagarkatti et al.	8,847,561 B2	9/2014	Karlieek et al.
7,777,567 B2	8/2010	Polizze	8,884,180 B2	11/2014	Ilic et al.
7,819,175 B2	10/2010	Zoodsma	8,884,525 B2	11/2014	Hoffman et al.
7,852,170 B2	12/2010	McKinzie, III	8,890,537 B2	11/2014	Valcore, Jr. et al.
7,863,996 B2	1/2011	Cotter et al.	8,912,771 B2	12/2014	Humphrey et al.
7,868,556 B2	1/2011	Xia	8,912,835 B2	12/2014	Nagarkatti et al.
7,871,830 B2	1/2011	Johal et al.	8,928,329 B2	1/2015	Downing et al.
7,872,523 B2	1/2011	Sivakurnar et al.	9,083,343 B1	7/2015	Li et al.
7,885,774 B2	2/2011	Swank	9,190,993 B1	11/2015	Li
7,917,104 B2	3/2011	Manssen et al.	9,496,122 B1*	11/2016	Bhutta ..... H01J 37/32091
7,917,105 B2	3/2011	Drogi et al.	2001/0022734 A1	9/2001	Sato
7,969,096 B2	6/2011	Chen	2002/0060914 A1	5/2002	Porter et al.
7,981,257 B2	7/2011	Krauss et al.	2003/0001511 A1	1/2003	Howald et al.
8,008,982 B2	8/2011	McKinzie, III	2003/0007372 A1	1/2003	Porter et al.
8,018,277 B2	9/2011	Drogi et al.	2003/0046013 A1	3/2003	Gerrish
8,040,068 B2	10/2011	Coumou et al.	2003/0097984 A1	5/2003	Nakano et al.
RE42,917 E	11/2011	Hauer et al.	2004/0100770 A1	5/2004	Chu et al.
8,089,026 B2	1/2012	Sellers	2005/0201055 A1	9/2005	Jyo et al.
8,102,954 B2	1/2012	Coumou	2005/0212450 A1	9/2005	Martinez et al.
8,110,991 B2	2/2012	Coumou	2006/0151591 A1	7/2006	Matsumo
8,203,859 B2	6/2012	Omae et al.	2006/0170367 A1	8/2006	Bhutta
8,217,731 B2	7/2012	McKinzie, III	2006/0198077 A1	9/2006	Bhutta
8,217,732 B2	7/2012	McKinzie, III	2006/0220595 A1	10/2006	Lu
8,228,112 B2	7/2012	Reynolds	2006/0226786 A1	10/2006	Lin et al.
8,237,501 B2	8/2012	Owen	2006/0232471 A1	10/2006	Coumou
8,264,154 B2	9/2012	Banner et al.	2007/0075784 A1	4/2007	Pettersson et al.
8,278,909 B2	10/2012	Fletcher	2007/0139122 A1	6/2007	Nagarkatti et al.
8,289,029 B2	10/2012	Coumou	2007/0146958 A1	6/2007	Babcock et al.
8,299,867 B2	10/2012	McKinzie, III	2007/0222769 A1	9/2007	Otsuka et al.
8,314,561 B2	11/2012	Fisk et al.	2007/0285894 A1	12/2007	Hatamian et al.
8,330,432 B2	12/2012	Van Zyl et al.	2008/0003962 A1	1/2008	Ngai
8,334,657 B2	12/2012	Xia	2008/0179948 A1	7/2008	Nagarkatti et al.
8,334,700 B2	12/2012	Coumou et al.	2008/0180179 A1	7/2008	Polizzo
8,335,479 B2	12/2012	Koya et al.	2008/0197854 A1	8/2008	Valcore et al.
8,344,559 B2	1/2013	Van Zyl et al.	2008/0228179 A1	9/2008	Eder et al.
8,344,801 B2	1/2013	Owen et al.	2009/0009232 A1	1/2009	Helfrich et al.
8,368,308 B2	2/2013	Banna et al.	2009/0009243 A1	1/2009	McCune
8,368,469 B2	2/2013	Mohammadi et al.	2009/0174496 A1	7/2009	Van Bezooijen
8,395,322 B2	3/2013	Coumou	2009/0207537 A1	8/2009	Coumou
8,415,885 B2	4/2013	Yamazama	2009/0229794 A1	9/2009	Schon
8,416,008 B2	4/2013	Van Zyl et al.	2009/0289719 A1	11/2009	Bezooijen et al.
8,436,643 B2	5/2013	Mason	2010/0001796 A1	1/2010	Sivakurnar et al.
8,452,243 B2	5/2013	Prikhodko et al.	2010/0039194 A1	2/2010	Darabi et al.
8,461,842 B2	6/2013	Thuringer et al.	2010/0073104 A1	3/2010	Cotter et al.
8,466,736 B1	6/2013	Reynolds	2010/0123502 A1	5/2010	Bhutta et al.
8,487,706 B2	7/2013	Li et al.	2010/0128431 A1	5/2010	Eriksen et al.
			2010/0194195 A1	8/2010	Coumou et al.
			2010/0201370 A1	8/2010	Coumou et al.
			2010/0231296 A1	9/2010	Nagarkatti et al.
			2010/0253442 A1	10/2010	Mu

(56)

References Cited

U.S. PATENT DOCUMENTS

2010/0315064 A1 12/2010 Kuthi et al.  
 2011/0241781 A1 10/2011 Owen et al.  
 2011/0247696 A1 10/2011 Zolock et al.  
 2011/0291738 A1 12/2011 Biela et al.  
 2012/0013253 A1 1/2012 Coumou  
 2012/0062322 A1 3/2012 Owen  
 2012/0067873 A1 3/2012 Mihara et al.  
 2012/0170321 A1 7/2012 Yang et al.  
 2012/0188007 A1 7/2012 Van Zyl et al.  
 2012/0262064 A1 10/2012 Nagarkatti et al.  
 2013/0043854 A1 2/2013 Tran et al.  
 2013/0169359 A1 7/2013 Coumou  
 2013/0193867 A1 8/2013 Van Zyl et al.  
 2013/0206367 A1 8/2013 Chen et al.  
 2013/0207738 A1 8/2013 Mason  
 2013/0221847 A1 8/2013 Choi  
 2013/0222055 A1 8/2013 Coumou et al.  
 2013/0257311 A1 10/2013 Tran et al.  
 2013/0314163 A1 11/2013 Costa  
 2013/0320853 A1 12/2013 Carter et al.  
 2014/0009248 A1 1/2014 Granger-Jones  
 2014/0028389 A1 1/2014 Coumou  
 2014/0028398 A1 1/2014 Owen  
 2014/0049250 A1 2/2014 Brown et al.  
 2014/0055034 A1 2/2014 Coumou  
 2014/0061156 A1 3/2014 Brouk et al.  
 2014/0062303 A1 3/2014 Hoffman et al.  
 2014/0097908 A1 4/2014 Fisk, II et al.  
 2014/0112414 A1 4/2014 Lu  
 2014/0117861 A1 5/2014 Finley et al.  
 2014/0117872 A1 5/2014 Finley  
 2014/0118031 A1 5/2014 Rughoonundon et al.  
 2014/0159741 A1 6/2014 Bannwarth et al.

2014/0195033 A1 7/2014 Lyndaker et al.  
 2014/0210345 A1 7/2014 Hoffman  
 2014/0210551 A1 7/2014 Mueller  
 2014/0218076 A1 8/2014 Coumou et al.  
 2014/0220913 A1 8/2014 Coumou et al.  
 2014/0231243 A1 8/2014 Finley  
 2014/0232266 A1 8/2014 Finley et al.  
 2014/0266492 A1 9/2014 Radomski et al.  
 2014/0306742 A1 10/2014 Menzer et al.  
 2014/0320013 A1 10/2014 Coumou et al.  
 2015/0091440 A1 4/2015 Marakhtanov et al.  
 2015/0115289 A1 4/2015 Fursin et al.  
 2015/0138722 A1 5/2015 French, Jr. et al.

FOREIGN PATENT DOCUMENTS

EP	0840349	5/1998
EP	0840350	5/1998
JP	2000036554	2/2000
WO	WO2004054096	6/2004
WO	WO2006096589	9/2006
WO	WO2008118342	10/2008
WO	WO2012076522	6/2012

OTHER PUBLICATIONS

Heckman, Randy, et al., "The Evolution of RF Power Deliver in Plasma Processing". Advance Energy Whitepaper, pp. 1-8, 1998.  
 Lei, Fan, et al., "An amplitude modulated radio frequency plasma generator". Physics of Plasmas 24, 043513 (2017), pp. 1-7.  
 Scott Gregory Bushman, "Process Monitoring, Modeling and Control of Plasma Etch Systems," Dissertation, The University of Texas at Austin, Dec. 1995, US.

\* cited by examiner

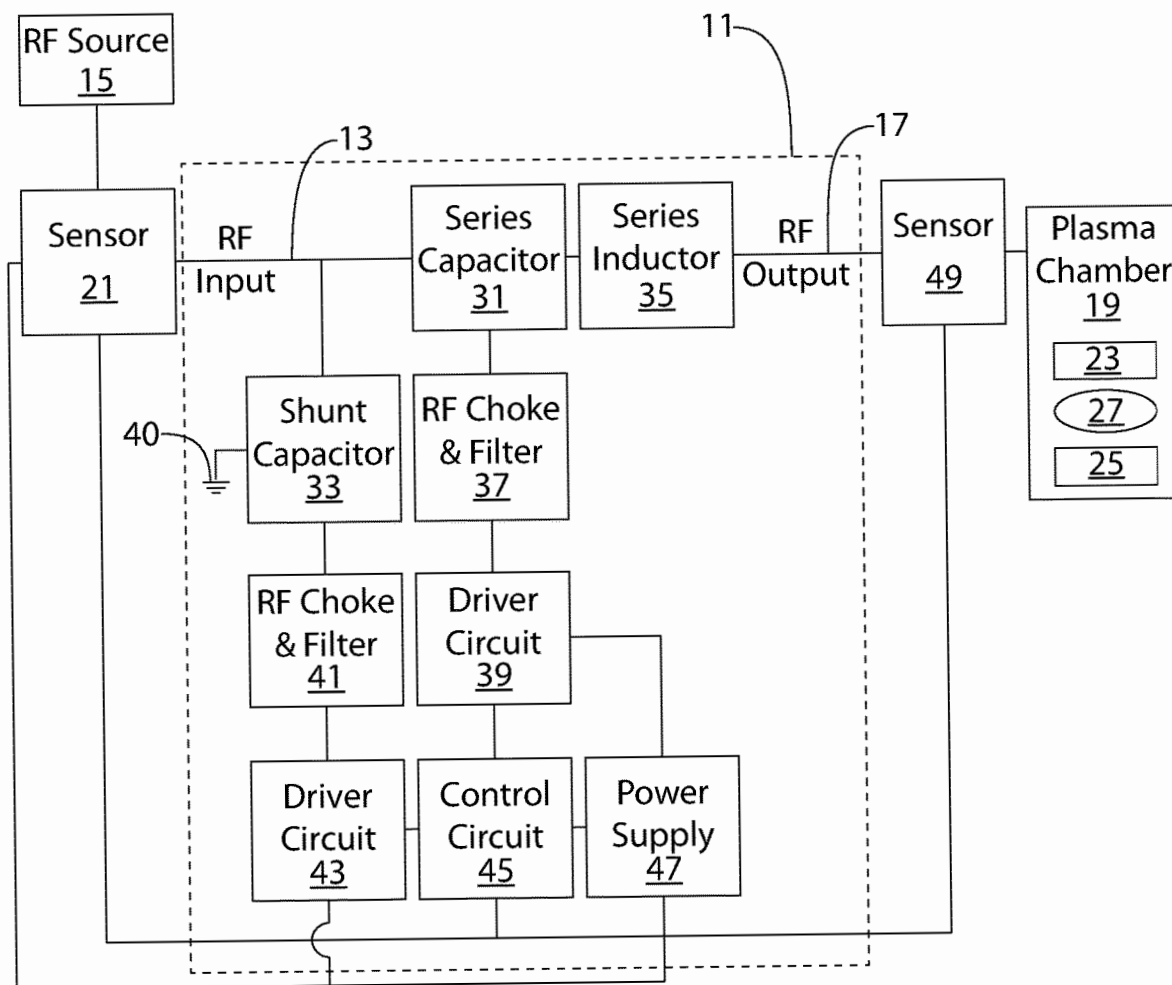

FIG. 1

# Explore Litigation Insights

Docket Alarm provides insights to develop a more informed litigation strategy and the peace of mind of knowing you're on top of things.

## Real-Time Litigation Alerts



Keep your litigation team up-to-date with **real-time alerts** and advanced team management tools built for the enterprise, all while greatly reducing PACER spend.

Our comprehensive service means we can handle Federal, State, and Administrative courts across the country.

## Advanced Docket Research



With over 230 million records, Docket Alarm's cloud-native docket research platform finds what other services can't. Coverage includes Federal, State, plus PTAB, TTAB, ITC and NLRB decisions, all in one place.

Identify arguments that have been successful in the past with full text, pinpoint searching. Link to case law cited within any court document via Fastcase.

## Analytics At Your Fingertips



Learn what happened the last time a particular judge, opposing counsel or company faced cases similar to yours.

Advanced out-of-the-box PTAB and TTAB analytics are always at your fingertips.

## API

Docket Alarm offers a powerful API (application programming interface) to developers that want to integrate case filings into their apps.

## LAW FIRMS

Build custom dashboards for your attorneys and clients with live data direct from the court.

Automate many repetitive legal tasks like conflict checks, document management, and marketing.

## FINANCIAL INSTITUTIONS

Litigation and bankruptcy checks for companies and debtors.

## E-DISCOVERY AND LEGAL VENDORS

Sync your system to PACER to automate legal marketing.