

09-17-01

A7

PATENT

Attorney Docket No. STRATOS.001A

Date: September 13, 2001

Page 1

11055 U.S. PTO
09/13/01

11017 U.S. PTO
09/953335
09/13/01

ASSISTANT COMMISSIONER FOR PATENTS

WASHINGTON, D.C. 20231

ATTENTION: BOX PATENT APPLICATION

Sir:

Transmitted herewith for filing is the patent application of

Inventor(s): **Kelly M. Christensen, Barry D. Thomas and Thomas J. Smyth**

For:

SYSTEM AND METHOD FOR ORDERING AND DELIVERING MEDIA CONTENT

Enclosed are:

- (X) Specification in 26 pages.
- (X) 3 sheet(s) of drawings.
- (X) Return prepaid postcard.

CLAIMS AS FILED

| FOR | NUMBER FILED | NUMBER EXTRA | RATE | FEE |
|--|--------------|--------------|-------|-------|
| Basic Fee | | | \$710 | \$710 |
| Total Claims | 26 - 20 = | 6 × | \$18 | \$108 |
| Independent Claims | 8 - 3 = | 5 × | \$80 | \$400 |
| If application contains any multiple dependent claims(s), then add | | | \$270 | \$N/A |

FILING FEE TO BE PAID \$1218
AT A LATER DATE

- (X) Please use Customer No. 20,995 for the correspondence address.

Lee W. Henderson
 Lee W. Henderson Ph.D.
 Registration No. 41,830
 Attorney of Record

H:\DOCS\LWHLWH-6189.DOC:jk
091301

FOR FEE 09/13/01

Lee W. Henderson, Ph.D.

Assistant Commissioner for Patents
Washington, D.C. 20231

CERTIFICATE OF MAILING BY "EXPRESS MAIL"

Attorney Docket No. : STRATOS.001A
Applicant(s) : Christensen, et al.
For : SYSTEM AND METHOD FOR ORDERING
AND DELIVERING MEDIA CONTENT
Attorney : Lee W. Henderson Ph.D.
"Express Mail"
Mailing Label No. : EL846184523US
Date of Deposit : September 13, 2001

I hereby certify that the accompanying

Specification in 26 pages; 3 sheets of drawings; Return Prepaid Postcard

are being deposited with the United States Postal Service "Express Mail Post Office to Addressee" service under 37 CFR 1.10 on the date indicated above and are addressed to the Assistant Commissioner for Patents, Washington, D.C. 20231.

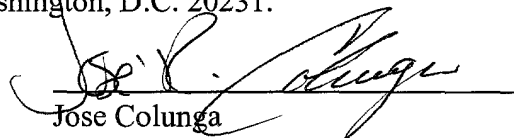
Jose Colunga

H:\DOCS\LWH\WH-6190.DOC:jk
091301

FOR FILING SEP 13 2001

TO THE "SECRET"

Many stations installed RBDS encoders through a program encouraged by the FCC in the early 1990's that provided encoders at no charge. Radio stations that did not participate in this "RBDS Roll-Out" can still obtain encoders at competitive prices.

5 RBDS encoders generate what is known as a "subcarrier" that modulates along with an FM station broadcast signal and can be demodulated by special decoders. The RBDS uses a subcarrier frequency of 57khz. Commercially available RBDS encoders usually accept information via either serial or parallel data ports and format the information into the appropriate RBDS block type.

10 The RBDS data signal is a specially encoded text stream containing up to 32 repeating data "groups" transmitting at 1187.5 bits/second. The RBDS data signal does not require inclusion of all potential data group blocks of both repeating and unique data. One embodiment includes using one of several groups that are designed for data transmission functions.

15 An RBDS data group is composed of 4 blocks, each divided by checkwords used for error correction. Block 1 is a 4-digit Program Identification code (PI) which is derived from the transmitting station's call letters. Block 2 includes a 4-bit type code and a 1-bit group version code which identifies the type of information the data group contains. This block also contains a 1-bit code that identifies the transmitting station as one that broadcasts traffic information, followed by a 5-bit Program Type (PTY) code
20 which describes the current program or format being broadcast by the station (Rock, Oldies, Talk, News, etc.). Information contained in Blocks 3 and 4 are dependent on the codes included in Block 2. Blocks 3 and 4 provide two 16-bit data slots where specific information can be sent to the special receiver.

25 For example, RBDS Group types 2A, use blocks 3 and 4 to transmit a 64-character text message known as RadioText (RT). This appears on RBDS-enabled radios as a scrolling message which some stations use to identify the song or program being broadcasted. Other group types use these blocks to identify alternate frequencies where the same programming can be available, in-house station text messages, or Emergency Alert System (EAS) communication messages. An extensive description of
30 the RBDS standard is available through the National Association of Broadcasters and the National Radio Systems Committee.

TOP SECRET

content or APS purchases using a Technology Enabled Radio (TER) or a personal computer.

5 In one embodiment, the user makes routing choices between the TER or the web account for content. In one embodiment, the user selects the compression type, such as MP3, RA, Liquid Audio etc.

10 In one embodiment, each broadcaster has an RBDS/RDS or similar technology enabled server onsite to, for example, generate RBDS/RDS or equivalent code for inclusion in the broadcast, validate and route purchase information to the user's wireless carrier for billing, monitor online sales transactions for data mining, or route validated purchases to licensed creative content providers.

15 In one embodiment, radio hardware can include, for example, RBDS/RDS or equivalent decoder capability (e.g., in an internal chip with APS code); flash card slot and recording ability; or storage of multiple items such as artist name, song title, IP address of creative content provider, and time stamp for delayed purchase (e.g., in an internal chip with APS code).

20 In one embodiment, the system uses the RBDS/RDS to send a data stream in combination with a broadcast signal for identifying music or speech content available for purchase. A broadcast organization participating in the APS system is able to respond to requests for purchases placed by users who either click a button or issue a voice command to the radio at the time of the content was broadcast, at a later time by scrolling through the playlist stored in the APS module in the radio then selecting one or more items for purchase from the list stored in the radio, or by accessing a private web account via the Internet and downloading content to the personal computer. In one embodiment, purchases are made by saving requests for selected items for purchase on a flash card or storage technology and transferring that data to a personal computer for purchase through the Internet at a later time.

25 Data such as song title and artist, author or publisher and the IP address for the location where the digital version of the content is stored, can be transmitted using the RBDS/RDS data stream. A reference number representing song title and artist, author or publisher and the IP address for the location where the digital version of the content is stored can also be employed for ease of implementation. This reference number can

FOR FILING

reside in a lookup table to be accessed by the APS server software on a Data Server located at the broadcast site, a remote site or both for purposes of redundancy. Transmission of purchase requests from a Technology Enabled Radio (TER) is provided via wireless transmission, or by accessing the Internet using a personal computer or through a cellular or wireless phone. In one embodiment, activity of each sale using the above system is tracked for the purposes of aggregating data or "Data Mining" for sale to interested parties such as trade publications and record companies.

Portable radios can come equipped with a voice interface or a purchase button, a flash card or storage device and a port for connecting the radio to the personal computer such as a 9 pin serial, USB or wireless networking technology.

Brief Description of the Drawings

Figure 1 illustrates an electronic purchasing system with a radio station that broadcasts information to individual radio receivers.

Figure 2 illustrates a radio receiver that includes an automatic purchasing system module.

Figure 3 illustrates a television adapter that includes an automatic purchasing system module.

Detailed Description of the Preferred Embodiment

The present invention solves various problems in the prior art by providing a system that allows an individual user to respond to a data broadcast. In one embodiment, an Automatic Purchase System (APS) provides a radio broadcast listener with the ability to conveniently purchase media content such as music or speech while listening to the radio. Additionally, the user can respond to items in the radio broadcast such as advertisements, fund raising drives such as those conducted by public radio, or interactive listener polls during the broadcast.

One of ordinary skill in the art will recognize that there are various forms of media that can be broadcast. Where a specific type of media is used in the following examples, it is for demonstration purposes only and the examples should not be limited

FOR PAGES 5-60

in that regard. Some examples of the various types of media can include music, songs, speech, text, video, etc.

5 Fig. 1 illustrates one embodiment of a system that allows a user to respond to a data broadcast. Fig. 1 shows a radio station 140 that broadcasts information to a radio receiver 100. The radio receiver 100 has a control interface 116 that allows a user to initiate a purchase of music or products based on the radio station broadcast.

10 The terms RBDS/RDS are used throughout this document, but it should be understood other data standards can also be used. In one embodiment, the radio receiver 100 comprises a Radio Frequency (RF) Demodulator Section 102, a RBDS/RDS Decoder 106, a RBDS/RDS function control interpreter 104, an audio demodulator amplifier section 108, a scrolling display 110, an Internet Download Director 112, a local memory device 114 and the control interface 116. Additionally, the receiver 100 provides for audio output by transmitting an audio signal 128 from an audio demodulator amplifier section 108 to the speaker 118.

15 In one embodiment, the RF Demodulator Section 102 splits the signal into an audio signal and a data signal, with the data signal provided to the RBDS/RDS decoder 106 and the audio signal provided to the audio demodulator amplifier section 108. The RBDS/RDS decoder 106 parses the data signal from the RF Demodulator Section 102 and transmits the data to the RBDS/RDS Function Controller 104, the Scrolling Display 110, and the Internet Download Director 112.

20 The RBDS/RDS Function Controller 104 handles codes 124 sent using the RBDS/RDS standard. The codes 124 can, for example, include a Program Service name (PS), a Program Type (PTY), a Program Identification (PI), a Traffic Program (TP), a Traffic Announcement (TA), etc.

25 In one embodiment, the data is converted to an audio signal played on one or more speakers for the user to hear. A 64 character radio text message can be transmitted in five seconds under the RBDS standard, where a Type 2A group with 4 characters is transmitted 3.2 times a second.

30 In one embodiment, a pointer to an Open Application Data (OAD) group is transmitted in a Type 3A group. The pointer, 16 message bits and 16 bit identifier (AID) are transmitted once a second.

FOR P. 150 SEE 960

In one embodiment, an OAD group with 37 usable bits is transmitted once a second during the broadcast of a “tagged” program. The OAD group can contain, for example, a song or commercial campaign identification.

5 In one embodiment, the scrolling display 110 receives display data 122 from the RBDS/RDS Decoder 106. The display data 122 can include information such as the program service name and program type, or it can include radio text information or messages displaying purchase options.

10 Additionally, the RBDS/RDS Decoder 106 provides data to the Internet Download Director 112 that includes instructions for the location of downloadable audio. For example, a radio station 140 can broadcast data regarding the current song that is playing, such as the song name, artist, album name, and year the song was recorded. The radio station 140 can also broadcast information providing a location where the song, editorial news broadcast, collection of songs, or other program material can be downloaded or purchased, and the purchase price for the song.

15 In one embodiment, a user can place an order to download a song using the control interface 116. The control interface 116 provides a download command signal 126 to the Internet Download Director 112. The Internet Download Director 112 can then provide download instructions such as, for example, the location of the file for download and the security procedures required for access. The download information is then transmitted over, for example, a wireless internet connection 156 to the authentication and billing system 152. The authentication and billing system 152 verifies the customer information and determines whether the customer account can be debited for the cost of the order. The authentication and billing system 152 then provides an approval signal 168 indicating whether the purchase was approved. The approval signal 168 is transmitted to the purchase database server 150.

20
25
30 Once the purchase is approved, the purchase database server 150 provides purchase and download authorization to the download server 154. The download server 154 can then transmit the requested material over a network connection 158. In one embodiment, the material is transmitted using a wireless internet connection directly to the radio receiver 100. In another embodiment, the material is made available to a personal computer. In one embodiment, the material is sent using traditional mail or

parcel services. The download server 154 also communicates with the audio database and encoding server 144 to provide available sound database information 164.

5 The radio station 140 includes a radio automation or CD playback system 142, an audio database/encoding server 144, an FM transmission system 146 and a RBDS/RDS encoder 148. The radio automation or CD playback system 142 can extract information about songs or a radio program from the station playlist or by extracting information encoded on a CD or a CD-ROM. The playlist information is provided to the audio database and coding server 144. The playlist information can include the song title, artist, cut or other information. The audio database/encoding server 144 matches
 10 the information sent from the radio automation system 142 with information in the database. If there is an audio file available for download, the database/encoding server 144 formats the download information and sends it to the RBDS/RDS encoder 148. Corresponding information is uploaded to the purchase database server 150.

15 The RBDS/RDS encoder 148 transmits the RBDS/RDS information using the 57khz RBDS/RDS subcarrier 170 to the FM transmission system 146. The RBDS/RDS subcarrier signal 170 is mixed by the FM transmission system 146 with the FM baseband program signal 172 and any other subcarriers. The FM transmission system 146 then transmits an FM RF signal 162 which is received by the radio receiver 100.

20 As shown in Fig. 1, a radio station 140, using either a standard radio automation system for tracking of music content which is being broadcast, or a data-enabled audio player, broadcasts audio material and synchronously sends RBDS/RDS or similar data to an APS server 144 that assigns a unique identifier to each specific broadcast segment or song.

25 The APS server 144 compares the broadcast segment identifier with a database 150 of audio available for purchase. If the broadcasted audio is available, the APS server 144 incorporates station call letter information, and an audio download location such as IP address and a file name into a data stream that is inserted into a radio station's broadcast using RBDS/RDS or similar technology. The information identifying the audio selected by the listener or user is routed to the APS Data Server
 30 and passed on to the location where a digital version of the audio content is stored and available for transfer to the end user. The user's radio receiver 100 receives and

recognizes the encoded RBDS/RDS or other data and presents it on the radio display 110 notifying the user that the audio is available for purchase.

If the user elects to purchase the audio content or responds to an ad or “pledge” drive, a request including the station’s data and the user’s cell phone or wireless Electronic Serial Number (ESN) or other identifier, such as a credit card number, combined with the audio content information is issued by the radio and passed via the cellular or wireless phone transmission to the APS Data Server and finally routed to the source server at the record company, publisher or licensed content provider. If a “good” connection is not available using the wireless connection, or the user does not have a wireless account, the information can be stored on the internal flash card or other storage device 114 in the radio for transfer to a personal computer at a time of the user’s choosing.

Each server typically records the purchase or response information. The storage server 154 at a source location then uploads the requested audio to the routing address associated with the user’s cell phone account identifier. The user’s receiver 100 then saves the audio on internal memory or a removable memory device or holds the audio content until the user chooses to download it using the Internet.

One embodiment includes the use of several group types reserved for “open data applications” by the RBDS/RDS standard. These groups were designed for use with data applications and are readily available for use.

Fig. 2 shows one example of a technology enabled radio 200. The radio 200 includes a module 202 for the Automatic Purchase System. In one embodiment, the APS provides relatively quick delivery of the purchased material. In one embodiment, quick delivery is provided by wireless transmission such that the user can receive the purchased material while traveling. In one embodiment, the system also provides delayed delivery, when, for example: the user so chooses; the user does not have a wireless account; or the user cannot obtain a good signal with a wireless connection for transmission.

In one embodiment, the radio 200 contains an APS module 202 configured to store identifier data 204, to provide security functions, and to assist in routing selections made by the user (using either a voice command issued to voice recognition technology

TO: "SEE" 5550

214 contained in the radio or by the press of a button 212 on the radio interface). In one embodiment, the APS module 202 is a proprietary microchip (or portion of a microchip) that implements the radio receiver-side functions of the APS. In one embodiment, the APS module 202 is a software module that runs on a processor in the radio 200.

5 The audio content can also be "tagged" for delayed purchase at a later time by scrolling through the playlist 208 stored in the APS module 202 on the radio 200 and presented on the external display 210 of the radio 200. The user can then select one or more items for purchase from the list presented on the display 210 (stored in the APS module 202 in the radio). In one embodiment, the selected items are transmitted using a
 10 wireless transmitter 218 such as a wireless telephone. In another embodiment, a user can store the playlist 208 on removable memory 220 that is readable by a personal computer 240. The user can then access a private web account via the Internet for downloading the content to the personal computer 240. At this point, the user can transfer the downloaded content to a storage device 242 such as, for example, a flash
 15 card or CD-ROM.

 Non-automotive or portable radios containing the APS module 202 can also include either a voice interface 214, an interactive button 212, or both, to enable listener-selection of broadcast material (or for responding to advertisements, fund raising drives, or any other interactive event). A port 216 such as a 9-pin serial port, a
 20 USB port, or any other port designed to provide connectivity between the radio 200 and a personal computer 240 can also be integrated into the radio 200 for the purposes of transferring the selection list from the APS module 202 to software in a personal computer 240 or other device. APS software running on the personal computer 240 is configured to recognize an embedded security code enabling purchase of the selected
 25 material via the Internet, or respond to an advertisement or fund raising drive. Wireless technology, such as, for example, BlueTooth and the like, can also be used for the purposes of transferring the selection data between devices.

 Automotive radios equipped with the APS module 202 and associated technologies can use a wireless interface 218 to send a purchase request (or interactive
 30 response) complete with a user Electronic Serial Number (ESN), WIN identifiers, and routing information such as artist and song title derived from the RBDS/RDS data string

accompanying the associated broadcast. The purchase request and routing information can then be directed to an APS server 260 for processing, billing approval, and delivery of the content to a particular location (such as the user's flash card or storage technology in the radio 200 or a personal account web URL), as requested by the user.

5 The flash card or storage technology 220 in the automotive radio offers the user a second option. The user can select content for purchase using the interactive voice technologies 214 or the button interface 212 to select broadcast content for purchase. If that user does not have a wireless phone, or does not have a good connection with a wireless phone connected to the radio, then the content selections can be stored on the
10 flash card or storage technology 220 for later use.

In one embodiment, the APS polls the wireless network until a good connection is obtained, at which point the selection data is transferred for completion of the transaction. In cases where the user cannot obtain a good connection or the user does not have a wireless account, the flash card or storage technology 220 can later be
15 removed by the user and inserted into a personal computer 240. The routing information for each selection stored on the flash card or storage technology 220 is passed to the APS download software running on the user's personal computer 240. Once the user has an active connection to the Internet, the APS download software allows the user to purchase the selected content and download it to a personal computer
20 240 as long as the content was tagged with the proper security codes obtained from the APS module 202 in the radio 200.

Using this system, the user can respond to a live broadcast radio advertisement to qualify for coupons, premiums or other sponsor-offered rewards. This system can also be applied to pledge drives employed by public radio stations, allowing listeners to
25 pledge money while driving or listening to a portable radio. The system can also be used for listener polls where the broadcaster can obtain quick responses from listeners to new music, speech content or general questions such as a talk show format. In each case, the user/listener can respond by pressing a "Respond" button 212 on the radio 200. On a voice-enabled radio 200, the user/listener can order content or provide responses
30 by voice commands.

FOR PUBLICATION

5 The user can also receive offers or hyperlinks posted on a personal web site presenting premiums such as discounted tickets (to events for the artists or writers for which they purchased content), suggestions of purchase for related artists or music genres, record company club offerings, or other premiums. Associated books, magazine articles, merchandise and event information can also be posted for the user to purchase using the APS. Hyperlinks can also be present for content not available on the radio but provided either through partnerships with existing digital content providers or content owners who have made direct arrangements for digital distribution through the APS web site.

10 Billing for the purchase of content and user-identification can be managed through the user's wireless phone account or the user can establish an account at an APS web site. Content purchased can be directed to Technology-Enabled Radios (TERs), or receivers using a wireless-telephone transmission, and stored on a flash card. Purchase content can also be directed to a personal web page assigned to the user upon creation of a specific account. The user can access the account over the Internet, and the user can download purchased content to a personal computer.

15 In order to protect the purchased content from piracy, various access-rights controls and copy-protections can be provided. In one embodiment, the user is allowed to copy purchased content to a CD or flash card one time only (unless additional licenses are purchased). Additional licenses can be purchased within the APS download software or in the user's web account by the click of a button or through using a third-party software package enabled with the APS security keys such as the ESN and WIN numbers from a wireless account.

20 Each sales transaction can be monitored by an APS server located at each participating radio station, by an Internet-based APS server, or both. The data collected through "data mining" of sales transactions can be sold to companies interested in tracking demographic information and music sales such as record companies and trade publications. In one embodiment, personal information regarding the users is not disclosed.

30 In one embodiment, the system includes one or more of the following features:

1. The user establishes a "Creative content" purchasing account with a wireless carrier.

FOR FILING

2. A personal URL (web address) is assigned to the user to:
 - Monitor account activity
 - Enable or disable APS software downloads
 - Display premiums offered by sponsors
 - 5 • Manage & track content or APS purchases using a TER or a personal computer.
 - User makes routing choice between the TER or the web account for content
 - User makes selection of compression type: MP3, RA, Liquid Audio etc.
 3. Each broadcaster has an RBDS/RDS or similar technology enabled server onsite to:
 - Generate RBDS/RDS or equivalent code for inclusion in the broadcast
 - 10 • Validate and route purchase information to the user's wireless carrier for billing
 - Monitor online sales transactions for data mining
 - Route validated purchase to licensed creative content providers
 4. Radio hardware can include:
 - RBDS/RDS or equivalent decoder capability (e.g., in an internal chip with APS
15 code)
 - Flash card slot and recording ability (Optional)
 - Storage of multiple items including: artist name, song title, IP address of
creative content provider, and time stamp for delayed purchase (e.g., in an
internal chip with APS code)
- 20 In one embodiment, the system uses the RBDS/RDS to send a data stream in combination with a broadcast signal for identifying music or speech content available for purchase. A broadcast organization participating in the APS system is able to respond to requests for purchase placed by users who either click a button or issue a voice command to the radio at the time of the content was broadcast, at a later time by
- 25 scrolling through the playlist stored in the APS module in the radio then selecting one or more items for purchase from the list stored in the radio, or by accessing a private web account via the Internet and downloading content to the personal computer. In one embodiment, purchases are made by saving requests for selected items for purchase on a flash card or storage technology and transferring that data to a personal computer for
- 30 purchase through the Internet at a later time.

5 Data such as song title and artist, author or publisher and the IP address for the location where the digital version of the content is stored, can be transmitted using the RBDS/RDS data stream. A reference number representing song title and artist, author or publisher and the IP address for the location where the digital version of the content is stored can also be employed for ease of implementation. This reference number can reside in a lookup table to be accessed by the APS server software on a Data Server located at the broadcast site, a remote site or both for purposes of redundancy. Transmission of purchase requests from a Technology Enabled Radio (TER) is provided via wireless transmission, or by accessing the Internet using a personal computer or
 10 through a cellular or wireless phone. In one embodiment, activity of each sale using the above system is tracked for the purposes of aggregating data or "Data Mining" for sale to interested parties such as trade publications and record companies.

15 Portable radios can come equipped with a voice interface or a purchase button, a flash card or storage device and a port for connecting the radio to the personal computer such as a 9 pin serial, USB or wireless networking technology.

20 Music radio stations often depend on computer-programmed and optimized playlists to ensure consistency and success of the format. Many stations use computer-based playback systems that play from hard disc libraries or control CD changers. At the start of the day, a playlist is loaded into these computers that include information. These "automation" systems provide continual logging of functions and activities and can output the "as played" information in a variety of ways, such as serial data. Data can be taken as an event occurs or can be read from a text file. Most automated systems can be programmed to send information out of the serial port.

25 Some stations have used this data to use RBDS/RDS and display song information in the RadioText group. More recently stations are using this information to feed a "now playing" message on Internet web sites.

30 Even stations that play CD's manually from a paper playlist can provide the information needed. Professional CD players usually have serial ports (i.e. RS232, RS485) that can be programmed to transmit CD code information. This code information is similar to the song codes used by internet-enabled computers to automatically download song information from the website known as CDDB.com for a

PETITIONER EX-1024

CD inserted into a CD-ROM player. Every RIAA-registered CD has a unique registered code with the RIAA. Thus, on an RIAA registered CD, a song can be identified by the registered code number in combination with the track number. For content that is not registered with the RIAA, a registration code is provided by APS. In one embodiment, the broadcaster providing the APS service to its listeners assigns an identifier code to the content. In one embodiment, an identifier code for non-RIAA registered content is provided by an APS registering organization or service.

In one embodiment, the system operates by acquiring playlist data or a reference number that identifies the broadcast content. The playlist data is included in the RBDS/RDS data sub-carrier by either the APS server software or a combination of the APS server software in conjunction with a compatible RDS/RBDS encoder.

Once the data source is identified, a connection pathway is established between the broadcaster and the APS Data Server. APS software residing on the APS Data Server stores that information in a "look up" table. The codes representing "cut numbers", or text song information such as artist and song title, are referenced against the internal look up table to determine if the song is available for download from the content owner such as a music publisher or record company. Once determination has been made regarding availability of the requested content, the APS software residing on the APS Data Server builds the data stream that can include the group 3 and group 4 data of the RBDS/RDS standard containing download location and/or file name. The APS software then transmits the information to a compatible RDS/RBDS encoder residing at the participating broadcaster.

For example: the 64-character text space contained in the RBDS standard is long enough to include an Internet IP address and directory location or reference code contained in a look up table capable of enabling the APS software to route the request for purchase from a user to the appropriate download site such as a publisher, record company or news organization.

The APS software residing on the APS Data Server can be employed to create the complete RBDS/RDS data signal and feed a slave encoder located at each broadcast location. The APS software also tracks each inquiry and purchase for billing verification and crediting the broadcaster for payment for their part in the sale. The

APS software also conducts data mining tracking for purposes of the future sale of transaction data.

In one embodiment, the RBDS/RDS encoder formats and encodes the non-APS elements of the data stream (such as station identification (Call Letters), date and time, etc.) and the APS software on the APS Data Server inserts content-specific data such as song title and artist information or author and news service, into the continual RBDS/RDS data stream through the RBDS/RDS encoder's standard interfaces. The APS Data Server software can be well suited to provide content specific information but the other RBDS/RDS group applications can be better managed by broadcast equipment designed for those applications.

RBDS/RDS is an FM-only transmission system but one of ordinary skill in the art will recognize that APS data can be included with other radio services (e.g. AM, etc.).

Digital Audio Broadcasting (DAB), which includes flexible, open-source, data transmission functions along with the audio signal. Systems for adapting digital audio and data transmission to the current allocation of AM and FM stations using a technique known as In Band On Channel (IBOC) are known. IBOC includes an ancillary data stream in the broadcast signal to be used by the station for whatever purposes they see fit. The ancillary data stream signal can be used to carry APS information.

Other developing radio systems also include a data path that can be used to send the information used by the APS system to successfully allow the acquisition of music or other material being broadcast. Satellite DAB providers, such as XM Satellite and Sirius Satellite Radio, have access to the audio and ancillary data signals being sent to compatible receivers.

As other audio services develop, the capability to transmit complimentary, simultaneous data can be used as a component of the APS. The APS can be simply adapted to each new transmission form with no significant change in the overall system.

Wireless technology and the related developments in high-speed Internet access using systems such as BlueTooth or other wireless network technology allows faster downloads of the desired material by taking advantage of the newer, faster technology.

FILED "SEE" 560

NTSC, PAL and other technologies employed to transmit television signals around the world allow for similar capabilities in transmitting subcarrier data within the carrier signal.

Fig. 3 shows one example of a Technology Enabled Television (TET) adapter 300. The television adapter 300 includes a module 302 for the Automatic Purchase System. In one embodiment, the television adapter 300 is incorporated into the television. In one embodiment, the television adapter 300 is a settop box. In one embodiment, the APS provides relatively quick delivery of the purchased material. The material available for purchase can cover a wide range of products, such as music, video, print, pledges of money, or consumer goods related to displayed advertisements. In one embodiment, quick delivery is provided by using a cable modem. In one embodiment, the television adapter 300 uses a modem and a telephone connection to download the data. In one embodiment, the television adapter 300 uses a network connection to download the data. In one embodiment, the system provides delayed delivery, when, for example: the user so chooses; the user does not have a cable modem; the user does not have a network account at that location; or the user cannot obtain a good signal with a wireless connection for transmission.

In one embodiment, a television adapter 300 contains an APS module 302 configured to store identifier data 304, to provide security functions, and to assist in routing selections made by the user (using either a voice command issued to voice recognition technology 314 contained in the television adapter or by the press of a button 312 on the television adapter interface). In one embodiment, the APS module 302 is a proprietary microchip (or portion of a microchip) that implements the television adapter-side functions of the APS. In one embodiment, the APS module 302 is a software module that runs on a processor in the television adapter 300.

The material can also be "tagged" for delayed purchase at a later time by scrolling through the selection list 308 stored in the APS module 302 on the television adapter 300 and presented on the external television display 380. The user can then select one or more items for purchase from the list presented on the display 380 (stored in the APS module 302 in the television adapter). In one embodiment, the selected items are transmitted using a cable modem. In one embodiment, the selected items are

TOP SECRET

transmitted using a wireless transmitter 318 such as a wireless telephone. In another embodiment, a user can store the selection list 308 on removable memory 320 that is readable by a personal computer 340. The user can then access a private web account via the Internet for downloading the content to the personal computer 340. At this point, the user can transfer the downloaded content to a storage device 342 such as, for example, a flash card or CD-ROM.

5
10
15
A port 316 such as a 9-pin serial port, a USB port, or any other port designed to provide connectivity between the television adapter 300 and a personal computer 340 can also be integrated into the television adapter 300 for the purposes of transferring the selection list from the APS module 302 to software in a personal computer 340 or other device. APS software running on the personal computer 340 is configured to recognize an embedded security code enabling purchase of the selected material via the Internet, or respond to an advertisement or fund raising drive. Wireless technology, such as, for example, BlueTooth and the like, can also be used for the purposes of transferring the selection data between devices.

20
25
In one embodiment, television adapters equipped with the APS module 302 and associated technologies can use a wireless interface 318 to send a purchase request (or interactive response) complete with a user Electronic Serial Number (ESN), WIN identifiers, and routing information such as artist and song title derived from the RBDS/RDS data string accompanying the associated broadcast. In one embodiment, television adapters can use a modem (e.g. a telephone modem, cable modem, etc.) or other network connection to send a purchase request. The purchase request and routing information can then be directed to an APS server 360 for processing, billing approval, and delivery of the content to a particular location (such as the user's flash card or storage technology in the television adapter 300 or a personal account web URL), as requested by the user. In one embodiment, the purchased material is delivered with traditional mail or parcel services.

30
The flash card or storage technology 320 in the television adapter offers the user a second option. The user can select content for purchase using the interactive voice technologies 314 or the button interface 312 to select broadcast content for purchase. If

FOR FILING

that user does not have a network connection, then the content selections can be stored on the flash card or storage technology 320 for later use.

5 User access to the APS is provided by the remote control, voice interaction or buttons on the actual TV. As a user views broadcast content, the user can respond to the television broadcast to make purchases, respond to an advertisement, to qualify for premiums, or the user can respond to pledge drives on public television or an interactive event such as a talk or game show.

10 In one embodiment, the user responses are provided to a computing device such as a personal computer, set-top box, and the like (e.g., via flash card or other removable storage medium, via a network connection between the computer and the TET, via a wireless connection such as BlueTooth, etc.). The computing device is then used to transfer the content in a manner similar to that described in the radio embodiment above.

15 In one embodiment, a cable connection from the TET to the computing device is used for immediate transfer of the user response. In one embodiment, data is transferred between the TET and the computing device using a communication port such as, for example, a serial port, a USB port, infrared port, a parallel port, and Ethernet port, or other port technology.

20 In one embodiment, the APS module also provides web-enabled cable or satellite television interactive services. In one embodiment, a modem (such as ,for example, a cable modem) is included in the TET thereby allowing the TET to send a user response request directly to a content provider (such as a cable company). In one embodiment, the APS module is provided in a cable set-top box to allow the APS system to be used with a conventional television.

25 The mechanisms for routing, customer identification, security, tracking, and purchase used with the radio embodiments described above can also be used with the TET.

30 It is understood that the download server, purchase database server, audio database server and encoding server can reside on one or more computers, and that the shown organization of the servers is for clarification. One or more programs can be used to perform part or all of the functions described in this description.

5 The foregoing description of a preferred implementation has been presented by way of example only, and should not be read in a limiting sense. Although this invention has been described in terms of certain preferred embodiments, other embodiments that are apparent to those of ordinary skill in the art, including embodiments which do not provide all of the benefits and features set forth herein, are also within the scope of this invention. Accordingly, the scope of the present invention is defined only by reference to the appended claims.

FOR OFFICIAL USE ONLY

WHAT IS CLAIMED IS:

1. A system for performing a transaction based on data provided as part of a broadcast signal, comprising:

5 a broadcast receiver circuit that extracts a RBDS data signal from a broadcast channel, said broadcast channel comprising an audio stream and a RBDS data stream that identifies program material in the audio stream;

a display capable of displaying information corresponding to the data signal;

10 a user input control that allows a user to select a transaction from the displayed information; and

an output device that provides a transaction request comprising an identity of a user and an identification of the selected transaction, said transaction request being provided to a response authentication system.

15 2. The system as in Claim 1, wherein the displayed information identifies a media file available for purchase.

3. The system as in Claim 2, further comprising an input to receive the purchased audio.

20 4. The system as in Claim 3, wherein the input is a wireless network connection.

5. The system as in Claim 1, wherein the output device is a removable memory device.

6. The system as in Claim 1, wherein the output device is a serial data port.

7. The system as in Claim 1, wherein the output device is a parallel data port.

25 8. The system as in Claim 1, wherein the output device is a wireless transmitter.

9. A system for responding to a data stream sent in combination with a media stream on a radio broadcast signal, comprising:

30 a broadcast receiver circuit that detects the radio broadcast signal and extracts a data signal from the data stream, at least a portion of the data signal configured to identify program content in said media stream;

memory for storing the data signal;

TOP SECRET

a display for displaying information corresponding to the data signal;
a user input control that allows a user to initiate a purchase request corresponding to the data signal;

5 a transmitter that transmits the purchase request to a response authentication system; and

a media download device for receiving media corresponding to said purchase request over a communications network.

10. The system as in Claim 9, wherein said user input control is a button.

11. The system as in Claim 9, wherein said user input control is a voice
10 command device.

12. The system as in Claim 9, wherein the data stream conforms to the Radio Broadcast Data System Standard.

13. The system as in Claim 9, wherein the data stream conforms to the Radio Data Service Standard.

15 14. The system as in Claim 9, wherein the transmitter uses a wireless connection.

15. The system as in Claim 9, wherein the transmitter uses an interface with a computer.

20 16. A response authentication system for processing requests sent in response to a data stream embedded within a broadcast radio signal, comprising:

a database that contains customer information;

a database that correlates a data stream identifier code with a location of the data stream on a communications network;

25 a server that correlates the receipt of a request for a specified data stream with information contained in the data stream location database, the request generated by user response to the broadcast radio signal having a program portion and a data portion, said data portion identifying said program portion; and

30 an order fulfillment server that receives communication of customer information.

17. The system as in Claim 16, wherein a completed order results in a download of a file corresponding to the specified data stream.

18. The system of Claim 16, wherein the data stream identifier code is extracted from identification information stored on a compact disc.

5 19. A method of providing a response to a data stream embedded within a broadcast channel, comprising the steps of:

extracting a digital data signal from a radio broadcast signal that comprises a modulated digital signal stream and a modulated analog signal stream;

10 demodulating the modulated analog signal stream and playing the demodulated analog signal stream;

displaying the digital data in a format that allows a user to identify and scroll through the contents of the digital data signal; and

15 transmitting a selection chosen from the displayed digital data by the user.

20. A method of receiving responses to an audio broadcast, comprising:

20 broadcasting a signal comprising an audio signal and an accompanying identifying data signal, where the data signal identifies the audio signal, wherein the data signal is broadcast in a format that allows a receiver to display to a user information about the audio signal;

receiving a response from a user that identifies the user and the audio signal that the user is responding to;

25 verifying the user identification and the availability of the audio signal; and

acting on the user response.

21. The method of Claim 20, wherein said acting on the user response comprises sending a media file.

22. The method of Claim 20, wherein said acting on the user response comprises transacting a donation.

30 23. The method of Claim 20, wherein said acting on the user response comprises sending a plurality of media files

TOP SECRET

24. A system for performing a transaction based on data provided as part of a broadcast signal, comprising:

5 a broadcast receiver circuit that extracts a data signal from a broadcast signal, said broadcast signal comprising an audio stream, a video stream and a data stream;

a display driver capable of displaying on a television screen information corresponding to the data signal;

a user input control that allows a user to select a transaction from the displayed information;

10 an output device that provides a transaction request comprising an identity of a user and an identification of the selected transaction, said transaction request being provided to a response authentication system.

25. A system for performing a transaction based on data provided as part of a broadcast signal, comprising:

15 a broadcast receiver circuit that extracts a data signal from a broadcast radio-frequency signal, said broadcast signal comprising an audio stream and a data stream;

a user input control that allows a user to initiate a transaction based on the audio stream content;

20 an output device that provides a transaction request comprising an identity of a user and an identification of the selected transaction, said transaction request being provided to a response authentication system.

26. A system for performing a transaction based on data provided as part of a broadcast radio-frequency signal, comprising:

25 a means for extracting a data signal from a broadcast channel, said broadcast channel comprising an audio stream and a data stream that identifies program material in the audio stream;

a means for displaying information corresponding to the data signal;

30 a means for allowing a user to select a transaction from the displayed information;

a means for requesting a transaction, said transaction request comprising an identity of a user and an identification of the selected transaction, said transaction request being provided to a response authentication system.

FOR THE SILENT

Abstract of the Disclosure

5 An Automatic Purchase System (APS) provides a radio broadcast listener with the ability to conveniently purchase media content such as music or speech while listening to the radio. The user can respond to items in the radio broadcast such as advertisements, fund raising drives such as those conducted by public radio, or interactive listener polls during the broadcast. Data such as song title and artist, author or publisher and the IP address for the location where the digital version of the content is stored, can be transmitted using the RBDS/RDS data stream. A reference number representing song title and artist, author or publisher and the IP address for the location where the digital version of the content is stored can also be employed for ease of implementation. This reference number can reside in a lookup table to be accessed by the APS server software on a Data Server located at the broadcast site, a remote site or both for purposes of redundancy. Transmission of purchase requests from a Technology Enabled Radio (TER) is provided via wireless transmission, or by accessing the Internet using a personal computer or through a cellular or wireless phone.

10

15

H:\DOCS\PDO\PDO-1078.DOC
091201

PDO-1078-091201

FIG. 100

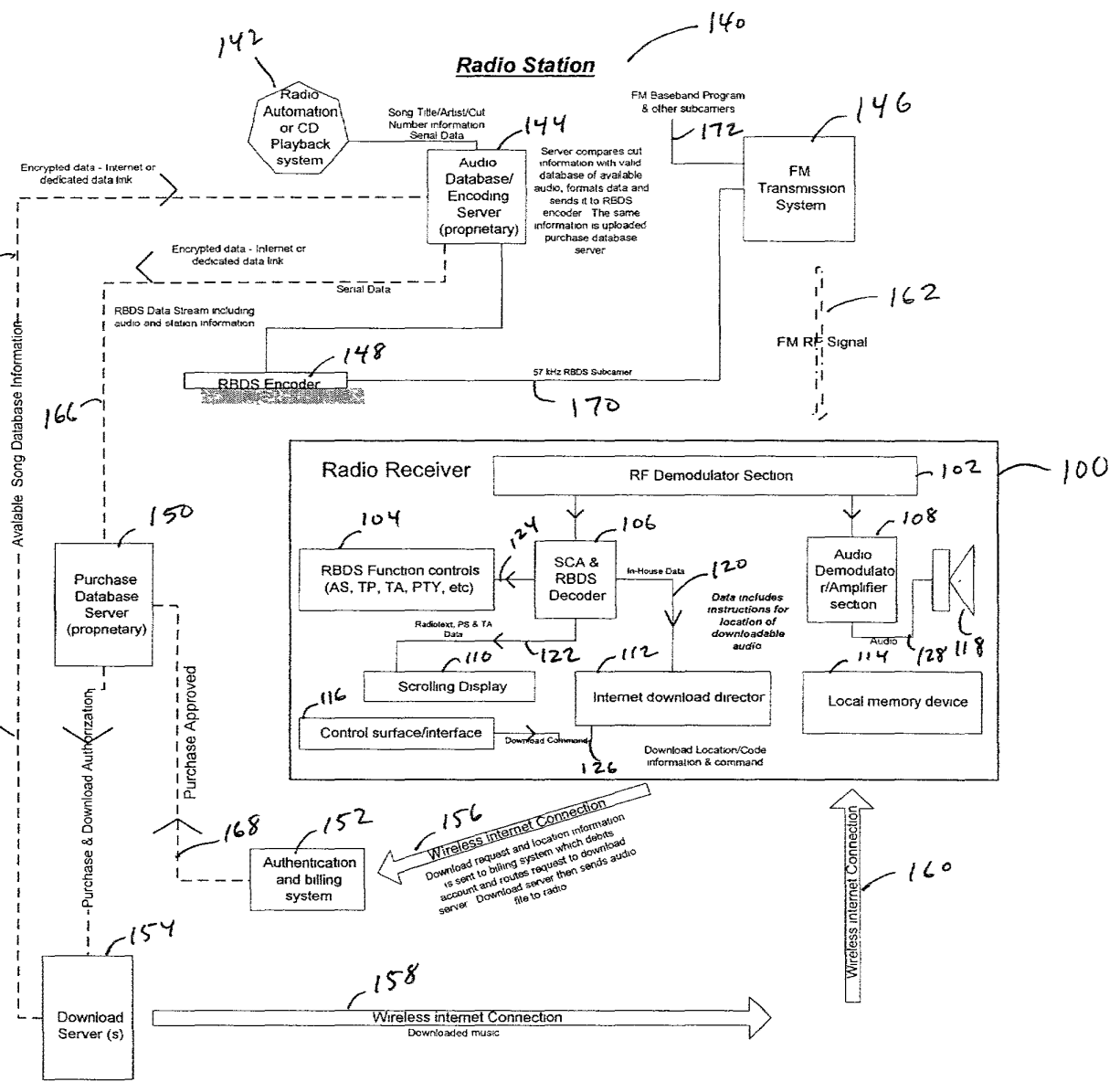

FIG. 1

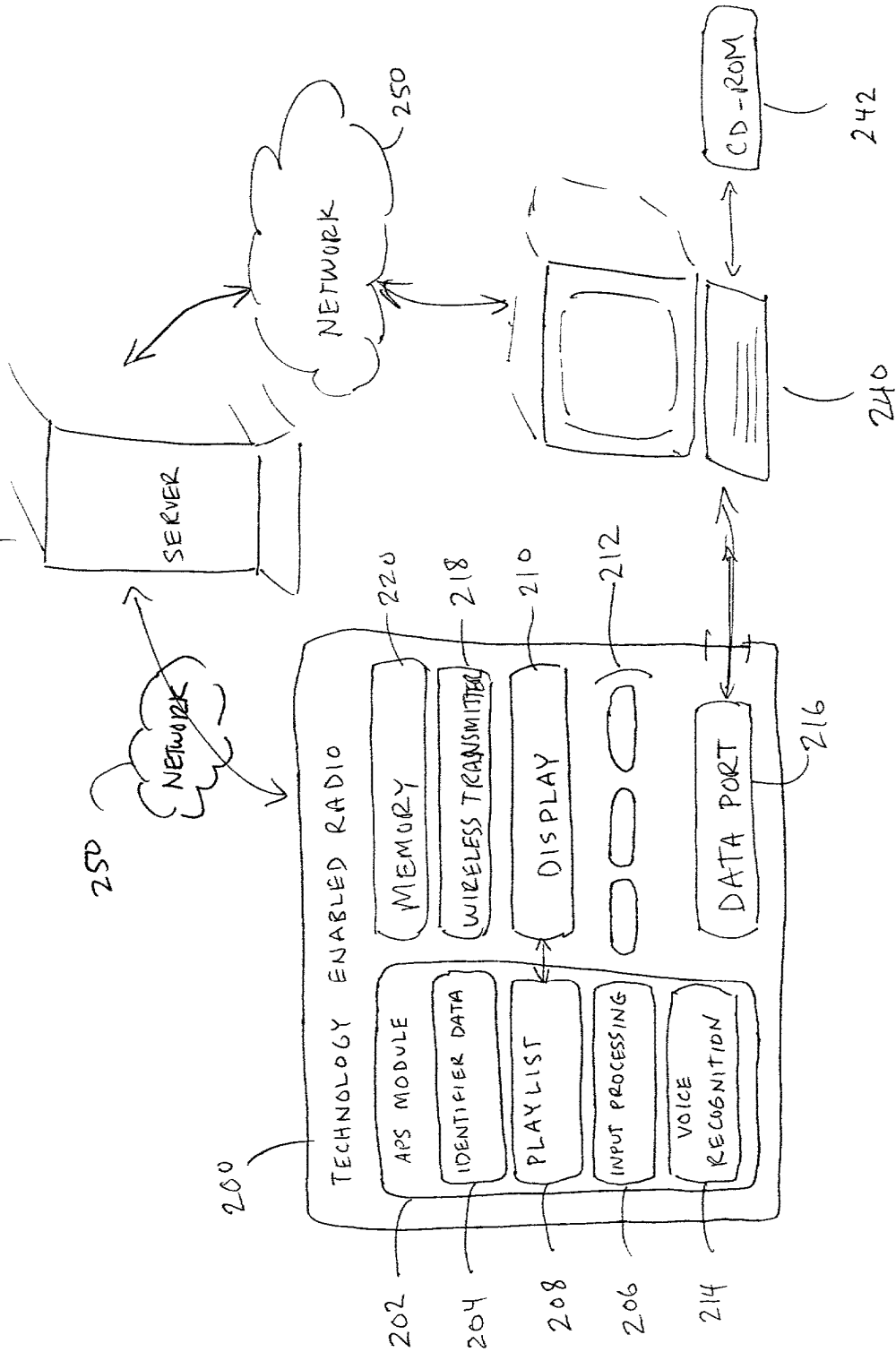

FIG. 2

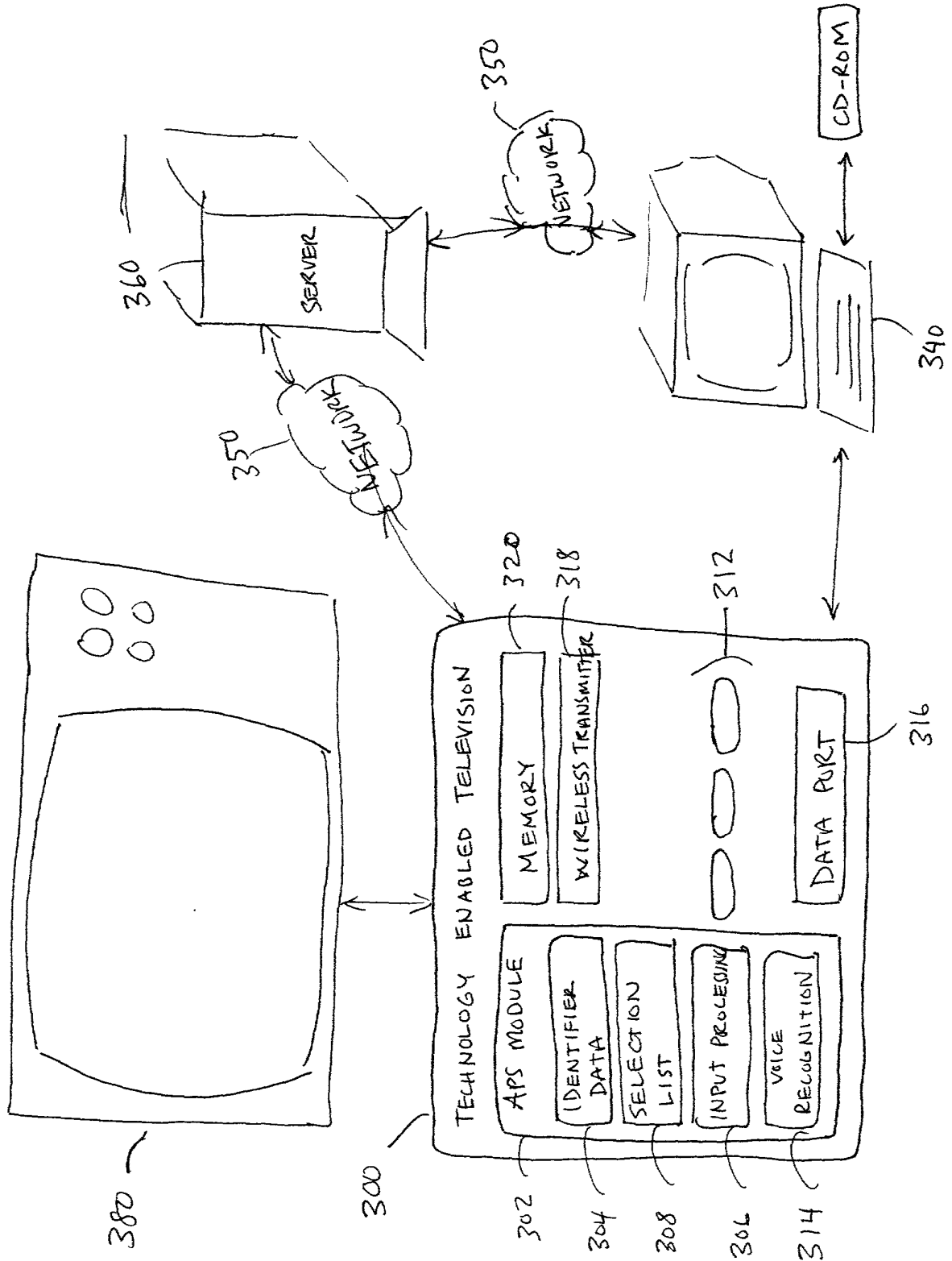

FIG. 3

JC4/956

11017 U.S. PTO
09/953335
09/13/01

| | | |
|-------|----------|----------------------|
| Class | Subclass | ISSUE CLASSIFICATION |
| | | |

PATENT NUMBER

U.S. UTILITY Patent Application

| | | |
|----------------------|----------------------------|-------------|
| M/E FA SCANNED | O.I.P.E. 117 Q.A. Am | PATENT DATE |
|----------------------|----------------------------|-------------|

| | | | | | |
|------------------------------|-----------------|---------------------|----------------|------------------|--------------------|
| APPLICATION NO. 09/953335 | CONT/PRIOR D | CLASS 455 705 | SUBCLASS 27 | ART UNIT 2681 | EXAMINER Kraner |
|------------------------------|-----------------|---------------------|----------------|------------------|--------------------|

APPLICANTS
Kelly Christensen
Barry Thomas
Thomas Smyth

2167

System and method for ordering and delivering media content

PTO-2040
12/99

BEST AVAILABLE COPY

| ISSUING CLASSIFICATION | | | | | | |
|------------------------------|----------|--------------------|-----------------------------------|--|--|--|
| ORIGINAL | | CROSS REFERENCE(S) | | | | |
| CLASS | SUBCLASS | CLASS | SUBCLASS (ONE SUBCLASS PER BLOCK) | | | |
| | | | | | | |
| INTERNATIONAL CLASSIFICATION | | | | | | |
| | | | | | | |
| | | | | | | |
| | | | | | | |
| | | | | | | |
| | | | | | | |
| | | | | | | |

Continued on Issue Slip Inside File Jacket

| | | | | | |
|---|-----------------|-------------|------------|-----------------------------------|----------------------|
| <input type="checkbox"/> TERMINAL DISCLAIMER | DRAWINGS | | | CLAIMS ALLOWED | |
| | Sheets Drwg. | Figs. Drwg. | Print Fig. | Total Claims | Print Claim for O.G. |
| <input type="checkbox"/> The term of this patent subsequent to _____ (date) has been disclaimed. | | | | NOTICE OF ALLOWANCE MAILED | |
| <input type="checkbox"/> The term of this patent shall not extend beyond the expiration date of U.S Patent. No. _____ | | | | ISSUE FEE | |
| | | | | Amount Due | Date Paid |
| <input type="checkbox"/> The terminal _____ months of this patent have been disclaimed. | | | | ISSUE BATCH NUMBER | |

WARNING:
The information disclosed herein may be restricted. Unauthorized disclosure may be prohibited by the United States Code Title 35, Sections 122, 181 and 368. Possession outside the U.S. Patent & Trademark Office is restricted to authorized employees and contractors only.

Form PTO-436A
(Rev. 6/99)

FILED WITH: DISK (CRF) FICHE CD-ROM
(Attached in pocket on right inside flap)

(FACE)

BEST AVAILABLE COPY

| SEARCHED | | | |
|----------|--------|---------|-------|
| Class | Sub. | Date | Exmr. |
| 705 | 26 | 6/20/03 | JAK |
| 705 | 27 | 6/20/03 | JAK |
| 705 | 26, 27 | 2/5/04 | JAK |
| 455 | 3.06 | | |
| 725 | 112 | | |

| INTERFERENCE SEARCHED | | | |
|-----------------------|------|------|-------|
| Class | Sub. | Date | Exmr. |
| | | | |
| | | | |

| SEARCH NOTES (INCLUDING SEARCH STRATEGY) | | |
|--|---------|-------|
| | Date | Exmr. |
| US Patents East SEARCH | 6/20/03 | JAK |
| US Patents East Word SEARCH | 2/5/04 | JAK |
| SEARCH Mecty w/ primary NGUYEN VO of 2685 class 455 | 2/2/04 | JAK |

(RIGHT OUTSIDE)

| POSITION | INITIALS | ID NO. | DATE |
|---------------------------|----------|--------|----------|
| FEE DETERMINATION | | | |
| O.I.P.E. CLASSIFIER | | WSW | 9/21/01 |
| FORMALITY REVIEW | VE | 956 | 10/12/01 |
| RESPONSE FORMALITY REVIEW | AS | 861 | 1-15-02 |

INDEX OF CLAIMS

- ✓ Rejected
- Allowed
- (Through numeral)... Canceled
- + Restricted
- N Non-elected
- I Interference
- A Appeal
- O Objected

BEST AVAILABLE COPY

| Claim | Final | Original | Date |
|-------|-------|----------|------|
| 1 | | | |
| 2 | | | |
| 3 | | | |
| 4 | | | |
| 5 | | | |
| 6 | | | |
| 7 | | | |
| 8 | | | |
| 9 | | | |
| 10 | | | |
| 11 | | | |
| 12 | | | |
| 13 | | | |
| 14 | | | |
| 15 | | | |
| 16 | | | |
| 17 | | | |
| 18 | | | |
| 19 | | | |
| 20 | | | |
| 21 | | | |
| 22 | | | |
| 23 | | | |
| 24 | | | |
| 25 | | | |
| 26 | | | |
| 27 | | | |
| 28 | | | |
| 29 | | | |
| 30 | | | |
| 31 | | | |
| 32 | | | |
| 33 | | | |
| 34 | | | |
| 35 | | | |
| 36 | | | |
| 37 | | | |
| 38 | | | |
| 39 | | | |
| 40 | | | |
| 41 | | | |
| 42 | | | |
| 43 | | | |
| 44 | | | |
| 45 | | | |
| 46 | | | |
| 47 | | | |
| 48 | | | |
| 49 | | | |
| 50 | | | |

| Claim | Final | Original | Date |
|-------|-------|----------|------|
| 51 | | | |
| 52 | | | |
| 53 | | | |
| 54 | | | |
| 55 | | | |
| 56 | | | |
| 57 | | | |
| 58 | | | |
| 59 | | | |
| 60 | | | |
| 61 | | | |
| 62 | | | |
| 63 | | | |
| 64 | | | |
| 65 | | | |
| 66 | | | |
| 67 | | | |
| 68 | | | |
| 69 | | | |
| 70 | | | |
| 71 | | | |
| 72 | | | |
| 73 | | | |
| 74 | | | |
| 75 | | | |
| 76 | | | |
| 77 | | | |
| 78 | | | |
| 79 | | | |
| 80 | | | |
| 81 | | | |
| 82 | | | |
| 83 | | | |
| 84 | | | |
| 85 | | | |
| 86 | | | |
| 87 | | | |
| 88 | | | |
| 89 | | | |
| 90 | | | |
| 91 | | | |
| 92 | | | |
| 93 | | | |
| 94 | | | |
| 95 | | | |
| 96 | | | |
| 97 | | | |
| 98 | | | |
| 99 | | | |
| 100 | | | |

| Claim | Final | Original | Date |
|-------|-------|----------|------|
| 101 | | | |
| 102 | | | |
| 103 | | | |
| 104 | | | |
| 105 | | | |
| 106 | | | |
| 107 | | | |
| 108 | | | |
| 109 | | | |
| 110 | | | |
| 111 | | | |
| 112 | | | |
| 113 | | | |
| 114 | | | |
| 115 | | | |
| 116 | | | |
| 117 | | | |
| 118 | | | |
| 119 | | | |
| 120 | | | |
| 121 | | | |
| 122 | | | |
| 123 | | | |
| 124 | | | |
| 125 | | | |
| 126 | | | |
| 127 | | | |
| 128 | | | |
| 129 | | | |
| 130 | | | |
| 131 | | | |
| 132 | | | |
| 133 | | | |
| 134 | | | |
| 135 | | | |
| 136 | | | |
| 137 | | | |
| 138 | | | |
| 139 | | | |
| 140 | | | |
| 141 | | | |
| 142 | | | |
| 143 | | | |
| 144 | | | |
| 145 | | | |
| 146 | | | |
| 147 | | | |
| 148 | | | |
| 149 | | | |
| 150 | | | |

Jc/1906
1/12/01
617
1-15-02

If more than 150 claims or 10 actions
staple additional sheet here

(LEFT INSIDE)

09-17-01

A

PATENT

Attorney Docket No. STRATOS.001A

Date: September 13, 2001

Page 1

11055 U.S. PTO
09/13/01

ASSISTANT COMMISSIONER FOR PATENTS

WASHINGTON, D.C. 20231

ATTENTION: BOX PATENT APPLICATION

Sir:

Transmitted herewith for filing is the patent application of

Inventor(s): Kelly M. Christensen, Barry D. Thomas and Thomas J. Smyth

For:

SYSTEM AND METHOD FOR ORDERING AND DELIVERING MEDIA CONTENT

Enclosed are:

- (X) Specification in 26 pages.
- (X) 3 sheet(s) of drawings.
- (X) Return prepaid postcard.

11017 U.S. PTO
09/953335
09/13/01

CLAIMS AS FILED

| FOR | NUMBER FILED | NUMBER EXTRA | RATE | FEE |
|--|--------------|--------------|-------|-------|
| Basic Fee | | | \$710 | \$710 |
| Total Claims | 26 - 20 = | 6 × | \$18 | \$108 |
| Independent Claims | 8 - 3 = | 5 × | \$80 | \$400 |
| If application contains any multiple dependent claims(s), then add | | | \$270 | \$N/A |

FILING FEE TO BE PAID \$1218
AT A LATER DATE

- (X) Please use Customer No. 20,995 for the correspondence address.

Lee W. Henderson

Lee W. Henderson Ph.D.
Registration No. 41,830
Attorney of Record

H:\DOCS\LWHLWH-6189.DOC:jk
091301

091301-000000000000000000

Lee W. Henderson, Ph.D.

Assistant Commissioner for Patents
Washington, D.C. 20231

CERTIFICATE OF MAILING BY "EXPRESS MAIL"

Attorney Docket No. : STRATOS.001A

Applicant(s) : Christensen, et al.

For : SYSTEM AND METHOD FOR ORDERING
AND DELIVERING MEDIA CONTENT

Attorney : Lee W. Henderson Ph.D.

"Express Mail"
Mailing Label No. : EL846184523US

Date of Deposit : September 13, 2001

I hereby certify that the accompanying

Specification in 26 pages; 3 sheets of drawings; Return Prepaid Postcard

are being deposited with the United States Postal Service "Express Mail Post Office to Addressee" service under 37 CFR 1.10 on the date indicated above and are addressed to the Assistant Commissioner for Patents, Washington, D.C. 20231.

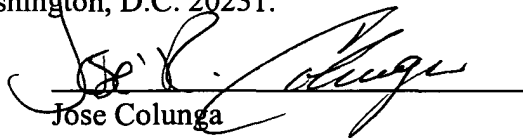

Jose Colunga

H:\DOCS\LWHL\WH-6190.DOC;jk
091301

FOR F60 SEES60

FIG. 1

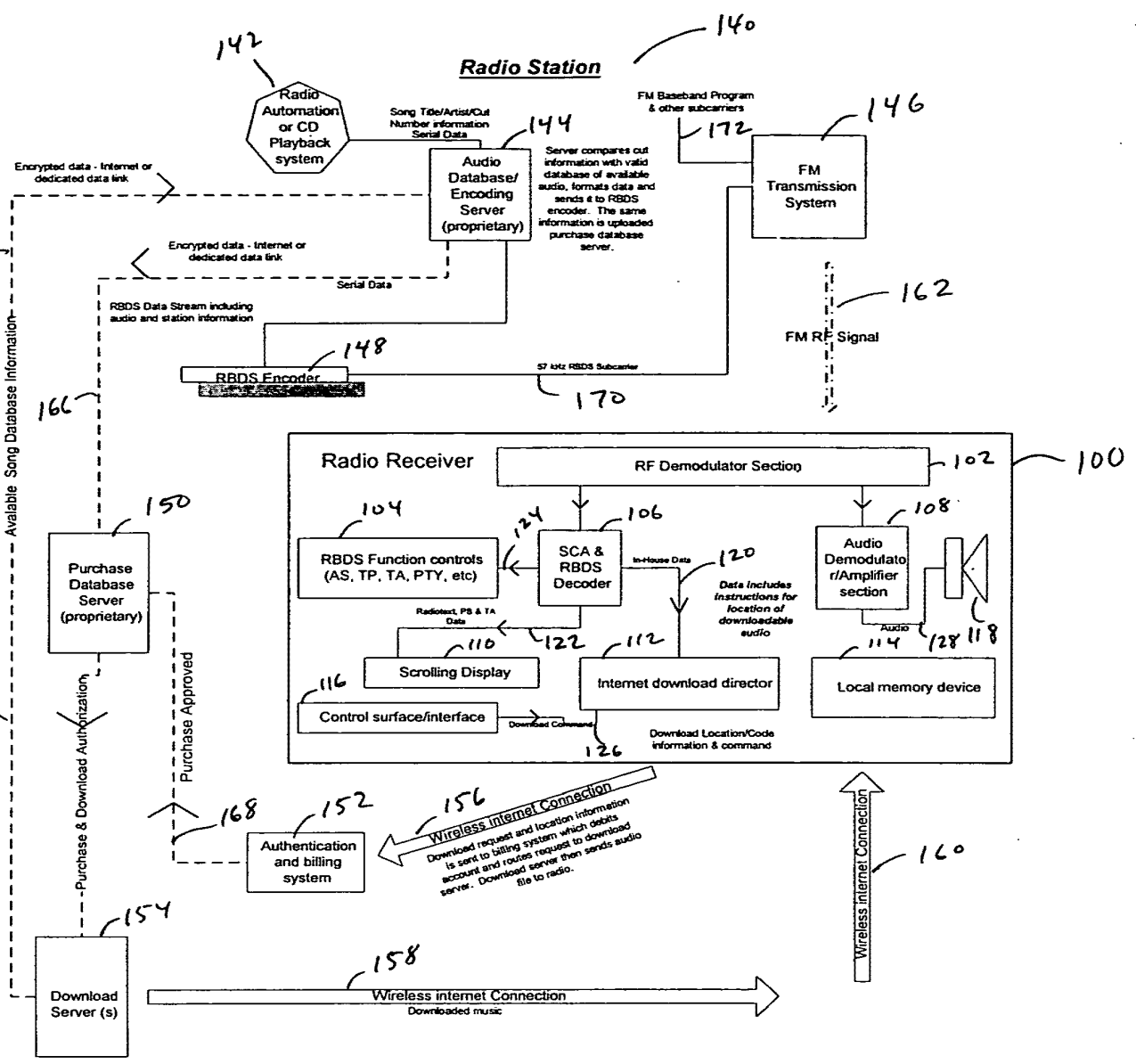

FIG. 1

TECHNOLOGY ENABLED RADIO

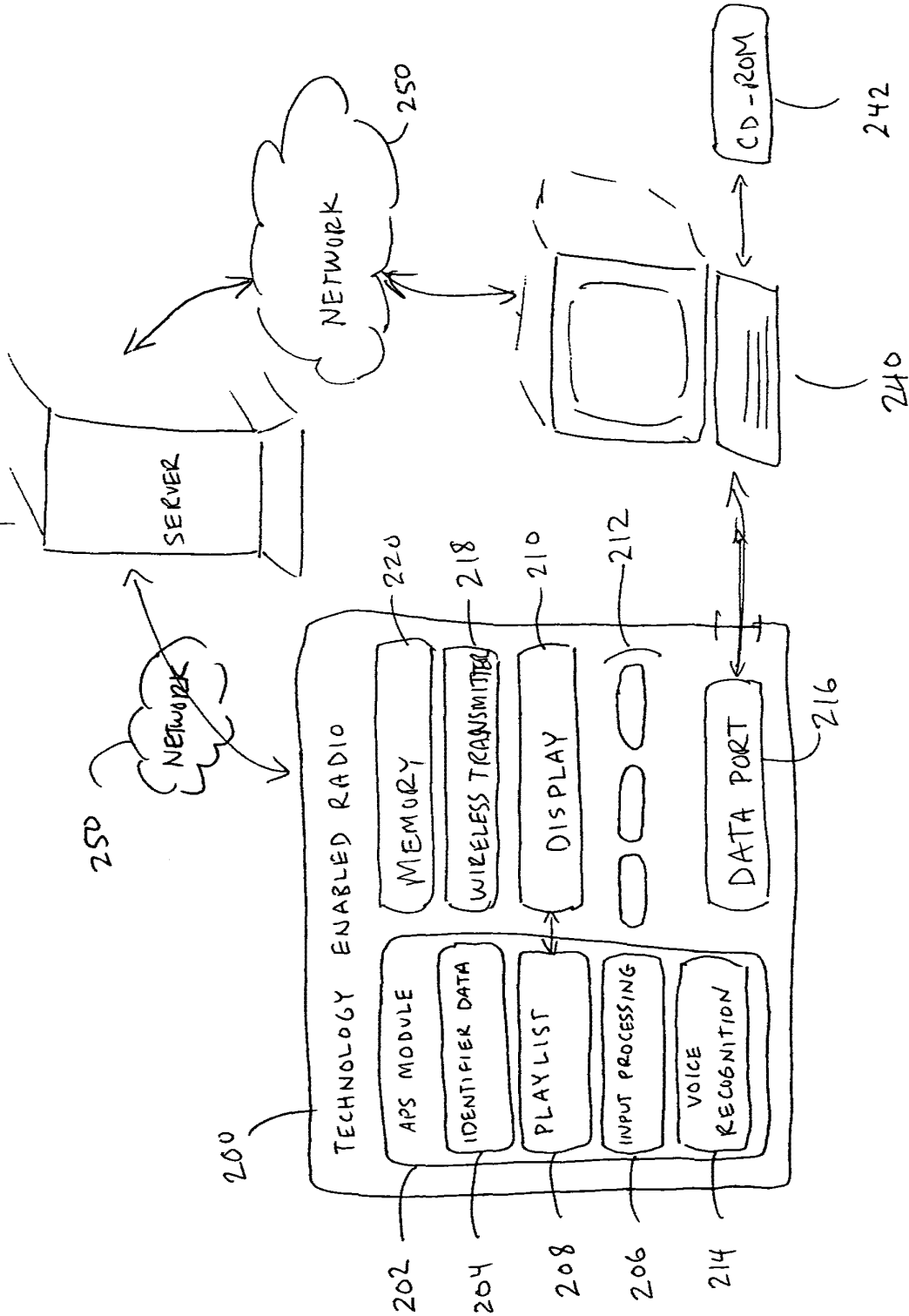

FIG. 2

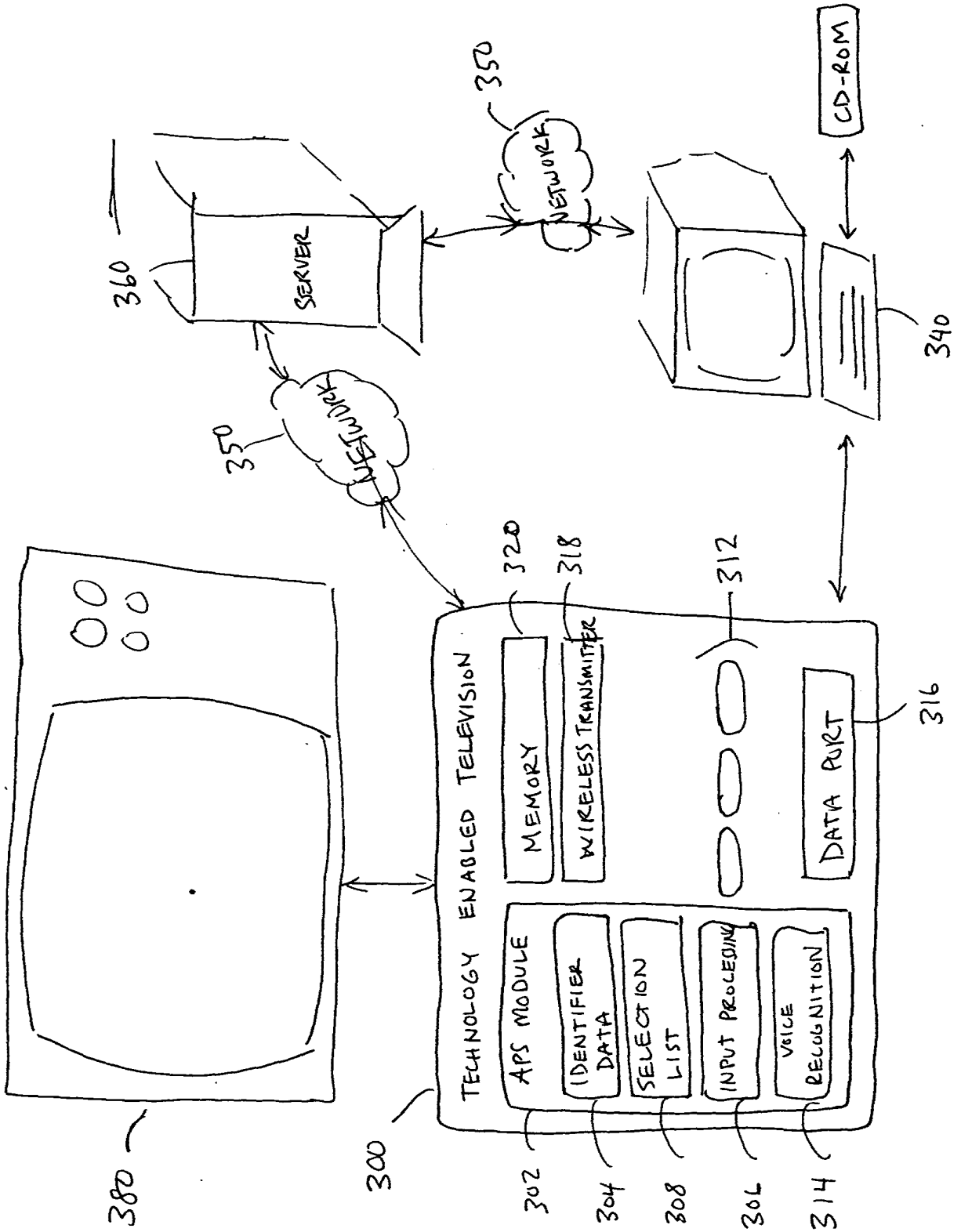

FIG. 3

**SYSTEM AND METHOD FOR ORDERING AND DELIVERING MEDIA
CONTENT**

5

Reference to Related Application

The present patent application claims priority benefit of U.S. Provisional Application No. 60/232,333, filed September 13, 2000, titled "SYSTEM AND METHOD FOR ORDERING AND DELIVERING MEDIA CONTENT," the content of which is hereby incorporated by reference in its entirety.

10

Background of the Invention

Field of the Invention

This invention relates to electronic purchasing systems, and more particularly to providing electronic purchasing in response to AM/FM radio broadcast.

15

Description of the Related Art

From the early days of FM broadcast transmission, stations have included ancillary signals such as background music or reading services for the blind along with a main carrier signal. The idea of transmitting data along with the main carrier signal caught on, and now many broadcast radio services either transmit an ancillary data signal or are developing a method to do so. The most current and widely used data transmission standard is the United States Radio Broadcast Data Systems ("RBDS") standard.

20

The RBDS standard, published by the National Radio Systems Committee and sponsored by the Electronics Industry Association and the National Association of Broadcasters, describes a system for broadcasting a variety of program-related information on a subcarrier of a standard FM broadcast channel. The RBDS standard teaches a system for transmitting station identification and location information, as well as time, traffic and miscellaneous other information.

25

The RBDS standard was designed to allow stations to send information such as call letters, station format, traffic alerts and scrolling text messages to compatible radios.

30

FOR "SEE 560"

Many stations installed RBDS encoders through a program encouraged by the FCC in the early 1990's that provided encoders at no charge. Radio stations that did not participate in this "RBDS Roll-Out" can still obtain encoders at competitive prices.

5 RBDS encoders generate what is known as a "subcarrier" that modulates along with an FM station broadcast signal and can be demodulated by special decoders. The RBDS uses a subcarrier frequency of 57khz. Commercially available RBDS encoders usually accept information via either serial or parallel data ports and format the information into the appropriate RBDS block type.

10 The RBDS data signal is a specially encoded text stream containing up to 32 repeating data "groups" transmitting at 1187.5 bits/second. The RBDS data signal does not require inclusion of all potential data group blocks of both repeating and unique data. One embodiment includes using one of several groups that are designed for data transmission functions.

15 An RBDS data group is composed of 4 blocks, each divided by checkwords used for error correction. Block 1 is a 4-digit Program Identification code (PI) which is derived from the transmitting station's call letters. Block 2 includes a 4-bit type code and a 1-bit group version code which identifies the type of information the data group contains. This block also contains a 1-bit code that identifies the transmitting station as one that broadcasts traffic information, followed by a 5-bit Program Type (PTY) code
20 which describes the current program or format being broadcast by the station (Rock, Oldies, Talk, News, etc.). Information contained in Blocks 3 and 4 are dependent on the codes included in Block 2. Blocks 3 and 4 provide two 16-bit data slots where specific information can be sent to the special receiver.

25 For example, RBDS Group types 2A, use blocks 3 and 4 to transmit a 64-character text message known as RadioText (RT). This appears on RBDS-enabled radios as a scrolling message which some stations use to identify the song or program being broadcasted. Other group types use these blocks to identify alternate frequencies where the same programming can be available, in-house station text messages, or Emergency Alert System (EAS) communication messages. An extensive description of
30 the RBDS standard is available through the National Association of Broadcasters and the National Radio Systems Committee.

TOE T B O " S E E S B O

content or APS purchases using a Technology Enabled Radio (TER) or a personal computer.

5 In one embodiment, the user makes routing choices between the TER or the web account for content. In one embodiment, the user selects the compression type, such as MP3, RA, Liquid Audio etc.

10 In one embodiment, each broadcaster has an RBDS/RDS or similar technology enabled server onsite to, for example, generate RBDS/RDS or equivalent code for inclusion in the broadcast, validate and route purchase information to the user's wireless carrier for billing, monitor online sales transactions for data mining, or route validated purchases to licensed creative content providers.

15 In one embodiment, radio hardware can include, for example, RBDS/RDS or equivalent decoder capability (e.g., in an internal chip with APS code); flash card slot and recording ability; or storage of multiple items such as artist name, song title, IP address of creative content provider, and time stamp for delayed purchase (e.g., in an internal chip with APS code).

20 In one embodiment, the system uses the RBDS/RDS to send a data stream in combination with a broadcast signal for identifying music or speech content available for purchase. A broadcast organization participating in the APS system is able to respond to requests for purchases placed by users who either click a button or issue a voice command to the radio at the time of the content was broadcast, at a later time by scrolling through the playlist stored in the APS module in the radio then selecting one or more items for purchase from the list stored in the radio, or by accessing a private web account via the Internet and downloading content to the personal computer. In one embodiment, purchases are made by saving requests for selected items for purchase on a
25 flash card or storage technology and transferring that data to a personal computer for purchase through the Internet at a later time.

30 Data such as song title and artist, author or publisher and the IP address for the location where the digital version of the content is stored, can be transmitted using the RBDS/RDS data stream. A reference number representing song title and artist, author or publisher and the IP address for the location where the digital version of the content is stored can also be employed for ease of implementation. This reference number can

FOR FIDELITY SERVICES

TO THE OFFICE

reside in a lookup table to be accessed by the APS server software on a Data Server located at the broadcast site, a remote site or both for purposes of redundancy. Transmission of purchase requests from a Technology Enabled Radio (TER) is provided via wireless transmission, or by accessing the Internet using a personal computer or through a cellular or wireless phone. In one embodiment, activity of each sale using the above system is tracked for the purposes of aggregating data or "Data Mining" for sale to interested parties such as trade publications and record companies.

Portable radios can come equipped with a voice interface or a purchase button, a flash card or storage device and a port for connecting the radio to the personal computer such as a 9 pin serial, USB or wireless networking technology.

Brief Description of the Drawings

Figure 1 illustrates an electronic purchasing system with a radio station that broadcasts information to individual radio receivers.

Figure 2 illustrates a radio receiver that includes an automatic purchasing system module.

Figure 3 illustrates a television adapter that includes an automatic purchasing system module.

Detailed Description of the Preferred Embodiment

The present invention solves various problems in the prior art by providing a system that allows an individual user to respond to a data broadcast. In one embodiment, an Automatic Purchase System (APS) provides a radio broadcast listener with the ability to conveniently purchase media content such as music or speech while listening to the radio. Additionally, the user can respond to items in the radio broadcast such as advertisements, fund raising drives such as those conducted by public radio, or interactive listener polls during the broadcast.

One of ordinary skill in the art will recognize that there are various forms of media that can be broadcast. Where a specific type of media is used in the following examples, it is for demonstration purposes only and the examples should not be limited

in that regard. Some examples of the various types of media can include music, songs, speech, text, video, etc.

5 Fig. 1 illustrates one embodiment of a system that allows a user to respond to a data broadcast. Fig. 1 shows a radio station 140 that broadcasts information to a radio receiver 100. The radio receiver 100 has a control interface 116 that allows a user to initiate a purchase of music or products based on the radio station broadcast.

10 The terms RBDS/RDS are used throughout this document, but it should be understood other data standards can also be used. In one embodiment, the radio receiver 100 comprises a Radio Frequency (RF) Demodulator Section 102, a RBDS/RDS Decoder 106, a RBDS/RDS function control interpreter 104, an audio demodulator amplifier section 108, a scrolling display 110, an Internet Download Director 112, a local memory device 114 and the control interface 116. Additionally, the receiver 100 provides for audio output by transmitting an audio signal 128 from an audio demodulator amplifier section 108 to the speaker 118.

15 In one embodiment, the RF Demodulator Section 102 splits the signal into an audio signal and a data signal, with the data signal provided to the RBDS/RDS decoder 106 and the audio signal provided to the audio demodulator amplifier section 108. The RBDS/RDS decoder 106 parses the data signal from the RF Demodulator Section 102 and transmits the data to the RBDS/RDS Function Controller 104, the Scrolling Display 110, and the Internet Download Director 112.

20 The RBDS/RDS Function Controller 104 handles codes 124 sent using the RBDS/RDS standard. The codes 124 can, for example, include a Program Service name (PS), a Program Type (PTY), a Program Identification (PI), a Traffic Program (TP), a Traffic Announcement (TA), etc.

25 In one embodiment, the data is converted to an audio signal played on one or more speakers for the user to hear. A 64 character radio text message can be transmitted in five seconds under the RBDS standard, where a Type 2A group with 4 characters is transmitted 3.2 times a second.

30 In one embodiment, a pointer to an Open Application Data (OAD) group is transmitted in a Type 3A group. The pointer, 16 message bits and 16 bit identifier (AID) are transmitted once a second.

Sub A2

FOR FILING

Sub
A3

In one embodiment, an OAD group with 37 usable bits is transmitted once a second during the broadcast of a "tagged" program. The OAD group can contain, for example, a song or commercial campaign identification.

5 In one embodiment, the scrolling display 110 receives display data 122 from the RBDS/RDS Decoder 106. The display data 122 can include information such as the program service name and program type, or it can include radio text information or messages displaying purchase options.

10 Additionally, the RBDS/RDS Decoder 106 provides data to the Internet Download Director 112 that includes instructions for the location of downloadable audio. For example, a radio station 140 can broadcast data regarding the current song that is playing, such as the song name, artist, album name, and year the song was recorded. The radio station 140 can also broadcast information providing a location where the song, editorial news broadcast, collection of songs, or other program material can be downloaded or purchased, and the purchase price for the song.

15 In one embodiment, a user can place an order to download a song using the control interface 116. The control interface 116 provides a download command signal 126 to the Internet Download Director 112. The Internet Download Director 112 can then provide download instructions such as, for example, the location of the file for download and the security procedures required for access. The download information is then transmitted over, for example, a wireless internet connection 156 to the authentication and billing system 152. The authentication and billing system 152 verifies the customer information and determines whether the customer account can be debited for the cost of the order. The authentication and billing system 152 then provides an approval signal 168 indicating whether the purchase was approved. The approval signal 168 is transmitted to the purchase database server 150.

20
25
30 Once the purchase is approved, the purchase database server 150 provides purchase and download authorization to the download server 154. The download server 154 can then transmit the requested material over a network connection 158. In one embodiment, the material is transmitted using a wireless internet connection directly to the radio receiver 100. In another embodiment, the material is made available to a personal computer. In one embodiment, the material is sent using traditional mail or

099333-0910 SEE 5660

parcel services. The download server 154 also communicates with the audio database and encoding server 144 to provide available sound database information 164.

The radio station 140 includes a radio automation or CD playback system 142, an audio database/encoding server 144, an FM transmission system 146 and a RBDS/RDS encoder 148. The radio automation or CD playback system 142 can extract information about songs or a radio program from the station playlist or by extracting information encoded on a CD or a CD-ROM. The playlist information is provided to the audio database and coding server 144. The playlist information can include the song title, artist, cut or other information. The audio database/encoding server 144 matches the information sent from the radio automation system 142 with information in the database. If there is an audio file available for download, the database/encoding server 144 formats the download information and sends it to the RBDS/RDS encoder 148. Corresponding information is uploaded to the purchase database server 150.

The RBDS/RDS encoder 148 transmits the RBDS/RDS information using the 57khz RBDS/RDS subcarrier 170 to the FM transmission system 146. The RBDS/RDS subcarrier signal 170 is mixed by the FM transmission system 146 with the FM baseband program signal 172 and any other subcarriers. The FM transmission system 146 then transmits an FM RF signal 162 which is received by the radio receiver 100.

As shown in Fig. 1, a radio station 140, using either a standard radio automation system for tracking of music content which is being broadcast, or a data-enabled audio player, broadcasts audio material and synchronously sends RBDS/RDS or similar data to an APS server 144 that assigns a unique identifier to each specific broadcast segment or song.

The APS server 144 compares the broadcast segment identifier with a database 150 of audio available for purchase. If the broadcasted audio is available, the APS server 144 incorporates station call letter information, and an audio download location such as IP address and a file name into a data stream that is inserted into a radio station's broadcast using RBDS/RDS or similar technology. The information identifying the audio selected by the listener or user is routed to the APS Data Server and passed on to the location where a digital version of the audio content is stored and available for transfer to the end user. The user's radio receiver 100 receives and

FOR FILING

FOR PAGES 5-10

recognizes the encoded RBDS/RDS or other data and presents it on the radio display 110 notifying the user that the audio is available for purchase.

5 If the user elects to purchase the audio content or responds to an ad or “pledge” drive, a request including the station’s data and the user’s cell phone or wireless Electronic Serial Number (ESN) or other identifier, such as a credit card number, combined with the audio content information is issued by the radio and passed via the cellular or wireless phone transmission to the APS Data Server and finally routed to the source server at the record company, publisher or licensed content provider. If a “good” connection is not available using the wireless connection, or the user does not have a wireless account, the information can be stored on the internal flash card or other storage device 114 in the radio for transfer to a personal computer at a time of the user’s choosing.

10 Each server typically records the purchase or response information. The storage server 154 at a source location then uploads the requested audio to the routing address associated with the user’s cell phone account identifier. The user’s receiver 100 then saves the audio on internal memory or a removable memory device or holds the audio content until the user chooses to download it using the Internet.

15 One embodiment includes the use of several group types reserved for “open data applications” by the RBDS/RDS standard. These groups were designed for use with data applications and are readily available for use.

20 Fig. 2 shows one example of a technology enabled radio 200. The radio 200 includes a module 202 for the Automatic Purchase System. In one embodiment, the APS provides relatively quick delivery of the purchased material. In one embodiment, quick delivery is provided by wireless transmission such that the user can receive the purchased material while traveling. In one embodiment, the system also provides delayed delivery, when, for example: the user so chooses; the user does not have a wireless account; or the user cannot obtain a good signal with a wireless connection for transmission.

25 In one embodiment, the radio 200 contains an APS module 202 configured to store identifier data 204, to provide security functions, and to assist in routing selections made by the user (using either a voice command issued to voice recognition technology

214 contained in the radio or by the press of a button 212 on the radio interface). In one embodiment, the APS module 202 is a proprietary microchip (or portion of a microchip) that implements the radio receiver-side functions of the APS. In one embodiment, the APS module 202 is a software module that runs on a processor in the radio 200.

5 The audio content can also be "tagged" for delayed purchase at a later time by scrolling through the playlist 208 stored in the APS module 202 on the radio 200 and presented on the external display 210 of the radio 200. The user can then select one or more items for purchase from the list presented on the display 210 (stored in the APS module 202 in the radio). In one embodiment, the selected items are transmitted using a
10 wireless transmitter 218 such as a wireless telephone. In another embodiment, a user can store the playlist 208 on removable memory 220 that is readable by a personal computer 240. The user can then access a private web account via the Internet for downloading the content to the personal computer 240. At this point, the user can transfer the downloaded content to a storage device 242 such as, for example, a flash
15 card or CD-ROM.

 Non-automotive or portable radios containing the APS module 202 can also include either a voice interface 214, an interactive button 212, or both, to enable listener-selection of broadcast material (or for responding to advertisements, fund raising drives, or any other interactive event). A port 216 such as a 9-pin serial port, a
20 USB port, or any other port designed to provide connectivity between the radio 200 and a personal computer 240 can also be integrated into the radio 200 for the purposes of transferring the selection list from the APS module 202 to software in a personal computer 240 or other device. APS software running on the personal computer 240 is configured to recognize an embedded security code enabling purchase of the selected
25 material via the Internet, or respond to an advertisement or fund raising drive. Wireless technology, such as, for example, BlueTooth and the like, can also be used for the purposes of transferring the selection data between devices.

 Automotive radios equipped with the APS module 202 and associated technologies can use a wireless interface 218 to send a purchase request (or interactive
30 response) complete with a user Electronic Serial Number (ESN), WIN identifiers, and routing information such as artist and song title derived from the RBDS/RDS data string

FOR THE "SEE560"

accompanying the associated broadcast. The purchase request and routing information can then be directed to an APS server 260 for processing, billing approval, and delivery of the content to a particular location (such as the user's flash card or storage technology in the radio 200 or a personal account web URL), as requested by the user.

5 The flash card or storage technology 220 in the automotive radio offers the user a second option. The user can select content for purchase using the interactive voice technologies 214 or the button interface 212 to select broadcast content for purchase. If that user does not have a wireless phone, or does not have a good connection with a wireless phone connected to the radio, then the content selections can be stored on the
10 flash card or storage technology 220 for later use.

 In one embodiment, the APS polls the wireless network until a good connection is obtained, at which point the selection data is transferred for completion of the transaction. In cases where the user cannot obtain a good connection or the user does not have a wireless account, the flash card or storage technology 220 can later be
15 removed by the user and inserted into a personal computer 240. The routing information for each selection stored on the flash card or storage technology 220 is passed to the APS download software running on the user's personal computer 240. Once the user has an active connection to the Internet, the APS download software allows the user to purchase the selected content and download it to a personal computer
20 240 as long as the content was tagged with the proper security codes obtained from the APS module 202 in the radio 200.

 Using this system, the user can respond to a live broadcast radio advertisement to qualify for coupons, premiums or other sponsor-offered rewards. This system can also be applied to pledge drives employed by public radio stations, allowing listeners to
25 pledge money while driving or listening to a portable radio. The system can also be used for listener polls where the broadcaster can obtain quick responses from listeners to new music, speech content or general questions such as a talk show format. In each case, the user/listener can respond by pressing a "Respond" button 212 on the radio 200. On a voice-enabled radio 200, the user/listener can order content or provide responses
30 by voice commands.

TOEFCO"SEE560

FOR FILED IN 56560

5 The user can also receive offers or hyperlinks posted on a personal web site presenting premiums such as discounted tickets (to events for the artists or writers for which they purchased content), suggestions of purchase for related artists or music genres, record company club offerings, or other premiums. Associated books, magazine articles, merchandise and event information can also be posted for the user to purchase using the APS. Hyperlinks can also be present for content not available on the radio but provided either through partnerships with existing digital content providers or content owners who have made direct arrangements for digital distribution through the APS web site.

10 Billing for the purchase of content and user-identification can be managed through the user's wireless phone account or the user can establish an account at an APS web site. Content purchased can be directed to Technology-Enabled Radios (TERs), or receivers using a wireless-telephone transmission, and stored on a flash card. Purchase content can also be directed to a personal web page assigned to the user upon creation of a specific account. The user can access the account over the Internet, and the user can download purchased content to a personal computer.

15 In order to protect the purchased content from piracy, various access-rights controls and copy-protections can be provided. In one embodiment, the user is allowed to copy purchased content to a CD or flash card one time only (unless additional licenses are purchased). Additional licenses can be purchased within the APS download software or in the user's web account by the click of a button or through using a third-party software package enabled with the APS security keys such as the ESN and WIN numbers from a wireless account.

20 Each sales transaction can be monitored by an APS server located at each participating radio station, by an Internet-based APS server, or both. The data collected through "data mining" of sales transactions can be sold to companies interested in tracking demographic information and music sales such as record companies and trade publications. In one embodiment, personal information regarding the users is not disclosed.

30 In one embodiment, the system includes one or more of the following features:
1. The user establishes a "Creative content" purchasing account with a wireless carrier.

FOR FILING - 09/25/04

- 2. A personal URL (web address) is assigned to the user to:
 - Monitor account activity
 - Enable or disable APS software downloads
 - Display premiums offered by sponsors
 - 5 • Manage & track content or APS purchases using a TER or a personal computer.
 - User makes routing choice between the TER or the web account for content
 - User makes selection of compression type: MP3, RA, Liquid Audio etc.
 - 3. Each broadcaster has an RBDS/RDS or similar technology enabled server onsite to:
 - Generate RBDS/RDS or equivalent code for inclusion in the broadcast
 - 10 • Validate and route purchase information to the user's wireless carrier for billing
 - Monitor online sales transactions for data mining
 - Route validated purchase to licensed creative content providers
 - 4. Radio hardware can include:
 - RBDS/RDS or equivalent decoder capability (e.g., in an internal chip with APS
15 code)
 - Flash card slot and recording ability (Optional)
 - Storage of multiple items including: artist name, song title, IP address of
creative content provider, and time stamp for delayed purchase (e.g., in an
internal chip with APS code)
- 20 In one embodiment, the system uses the RBDS/RDS to send a data stream in combination with a broadcast signal for identifying music or speech content available for purchase. A broadcast organization participating in the APS system is able to respond to requests for purchase placed by users who either click a button or issue a voice command to the radio at the time of the content was broadcast, at a later time by
- 25 scrolling through the playlist stored in the APS module in the radio then selecting one or more items for purchase from the list stored in the radio, or by accessing a private web account via the Internet and downloading content to the personal computer. In one embodiment, purchases are made by saving requests for selected items for purchase on a flash card or storage technology and transferring that data to a personal computer for
- 30 purchase through the Internet at a later time.

TOE T60 5EE560

5 Data such as song title and artist, author or publisher and the IP address for the location where the digital version of the content is stored, can be transmitted using the RBDS/RDS data stream. A reference number representing song title and artist, author or publisher and the IP address for the location where the digital version of the content is stored can also be employed for ease of implementation. This reference number can reside in a lookup table to be accessed by the APS server software on a Data Server located at the broadcast site, a remote site or both for purposes of redundancy. Transmission of purchase requests from a Technology Enabled Radio (TER) is provided via wireless transmission, or by accessing the Internet using a personal computer or
10 through a cellular or wireless phone. In one embodiment, activity of each sale using the above system is tracked for the purposes of aggregating data or "Data Mining" for sale to interested parties such as trade publications and record companies.

15 Portable radios can come equipped with a voice interface or a purchase button, a flash card or storage device and a port for connecting the radio to the personal computer such as a 9 pin serial, USB or wireless networking technology.

20 Music radio stations often depend on computer-programmed and optimized playlists to ensure consistency and success of the format. Many stations use computer-based playback systems that play from hard disc libraries or control CD changers. At the start of the day, a playlist is loaded into these computers that include information. These "automation" systems provide continual logging of functions and activities and can output the "as played" information in a variety of ways, such as serial data. Data can be taken as an event occurs or can be read from a text file. Most automated systems can be programmed to send information out of the serial port.

25 Some stations have used this data to use RBDS/RDS and display song information in the RadioText group. More recently stations are using this information to feed a "now playing" message on Internet web sites.

30 Even stations that play CD's manually from a paper playlist can provide the information needed. Professional CD players usually have serial ports (i.e. RS232, RS485) that can be programmed to transmit CD code information. This code information is similar to the song codes used by internet-enabled computers to automatically download song information from the website known as CDDDB.com for a

FOR THE RECORD

5 CD inserted into a CD-ROM player. Every RIAA-registered CD has a unique registered code with the RIAA. Thus, on an RIAA registered CD, a song can be identified by the registered code number in combination with the track number. For content that is not registered with the RIAA, a registration code is provided by APS. In one embodiment, the broadcaster providing the APS service to its listeners assigns an identifier code to the content. In one embodiment, an identifier code for non-RIAA registered content is provided by an APS registering organization or service.

10 In one embodiment, the system operates by acquiring playlist data or a reference number that identifies the broadcast content. The playlist data is included in the RBDS/RDS data sub-carrier by either the APS server software or a combination of the APS server software in conjunction with a compatible RDS/RBDS encoder.

15 Once the data source is identified, a connection pathway is established between the broadcaster and the APS Data Server. APS software residing on the APS Data Server stores that information in a "look up" table. The codes representing "cut numbers", or text song information such as artist and song title, are referenced against the internal look up table to determine if the song is available for download from the content owner such as a music publisher or record company. Once determination has been made regarding availability of the requested content, the APS software residing on the APS Data Server builds the data stream that can include the group 3 and group 4 data of the RBDS/RDS standard containing download location and/or file name. The APS software then transmits the information to a compatible RDS/RBDS encoder residing at the participating broadcaster.

20 For example: the 64-character text space contained in the RBDS standard is long enough to include an Internet IP address and directory location or reference code contained in a look up table capable of enabling the APS software to route the request for purchase from a user to the appropriate download site such as a publisher, record company or news organization.

25 The APS software residing on the APS Data Server can be employed to create the complete RBDS/RDS data signal and feed a slave encoder located at each broadcast location. The APS software also tracks each inquiry and purchase for billing verification and crediting the broadcaster for payment for their part in the sale. The

APS software also conducts data mining tracking for purposes of the future sale of transaction data.

5 In one embodiment, the RBDS/RDS encoder formats and encodes the non-APS elements of the data stream (such as station identification (Call Letters), date and time, etc.) and the APS software on the APS Data Server inserts content-specific data such as song title and artist information or author and news service, into the continual RBDS/RDS data stream through the RBDS/RDS encoder's standard interfaces. The APS Data Server software can be well suited to provide content specific information but the other RBDS/RDS group applications can be better managed by broadcast equipment
10 designed for those applications.

RBDS/RDS is an FM-only transmission system but one of ordinary skill in the art will recognize that APS data can be included with other radio services (e.g. AM, etc.).

15 Digital Audio Broadcasting (DAB), which includes flexible, open-source, data transmission functions along with the audio signal. Systems for adapting digital audio and data transmission to the current allocation of AM and FM stations using a technique known as In Band On Channel (IBOC) are known. IBOC includes an ancillary data stream in the broadcast signal to be used by the station for whatever purposes they see fit. The ancillary data stream signal can be used to carry APS information.

20 Other developing radio systems also include a data path that can be used to send the information used by the APS system to successfully allow the acquisition of music or other material being broadcast. Satellite DAB providers, such as XM Satellite and Sirius Satellite Radio, have access to the audio and ancillary data signals being sent to compatible receivers.

25 As other audio services develop, the capability to transmit complimentary, simultaneous data can be used as a component of the APS. The APS can be simply adapted to each new transmission form with no significant change in the overall system.

30 Wireless technology and the related developments in high-speed Internet access using systems such as BlueTooth or other wireless network technology allows faster downloads of the desired material by taking advantage of the newer, faster technology.

095335-01075660

NTSC, PAL and other technologies employed to transmit television signals around the world allow for similar capabilities in transmitting subcarrier data within the carrier signal.

Fig. 3 shows one example of a Technology Enabled Television (TET) adapter 300. The television adapter 300 includes a module 302 for the Automatic Purchase System. In one embodiment, the television adapter 300 is incorporated into the television. In one embodiment, the television adapter 300 is a settop box. In one embodiment, the APS provides relatively quick delivery of the purchased material. The material available for purchase can cover a wide range of products, such as music, video, print, pledges of money, or consumer goods related to displayed advertisements. In one embodiment, quick delivery is provided by using a cable modem. In one embodiment, the television adapter 300 uses a modem and a telephone connection to download the data. In one embodiment, the television adapter 300 uses a network connection to download the data. In one embodiment, the system provides delayed delivery, when, for example: the user so chooses; the user does not have a cable modem; the user does not have a network account at that location; or the user cannot obtain a good signal with a wireless connection for transmission.

In one embodiment, a television adapter 300 contains an APS module 302 configured to store identifier data 304, to provide security functions, and to assist in routing selections made by the user (using either a voice command issued to voice recognition technology 314 contained in the television adapter or by the press of a button 312 on the television adapter interface). In one embodiment, the APS module 302 is a proprietary microchip (or portion of a microchip) that implements the television adapter-side functions of the APS. In one embodiment, the APS module 302 is a software module that runs on a processor in the television adapter 300.

The material can also be "tagged" for delayed purchase at a later time by scrolling through the selection list 308 stored in the APS module 302 on the television adapter 300 and presented on the external television display 380. The user can then select one or more items for purchase from the list presented on the display 380 (stored in the APS module 302 in the television adapter). In one embodiment, the selected items are transmitted using a cable modem. In one embodiment, the selected items are

FOR THE "SEE560"

TELEVISION

transmitted using a wireless transmitter 318 such as a wireless telephone. In another embodiment, a user can store the selection list 308 on removable memory 320 that is readable by a personal computer 340. The user can then access a private web account via the Internet for downloading the content to the personal computer 340. At this point, the user can transfer the downloaded content to a storage device 342 such as, for example, a flash card or CD-ROM.

A port 316 such as a 9-pin serial port, a USB port, or any other port designed to provide connectivity between the television adapter 300 and a personal computer 340 can also be integrated into the television adapter 300 for the purposes of transferring the selection list from the APS module 302 to software in a personal computer 340 or other device. APS software running on the personal computer 340 is configured to recognize an embedded security code enabling purchase of the selected material via the Internet, or respond to an advertisement or fund raising drive. Wireless technology, such as, for example, BlueTooth and the like, can also be used for the purposes of transferring the selection data between devices.

In one embodiment, television adapters equipped with the APS module 302 and associated technologies can use a wireless interface 318 to send a purchase request (or interactive response) complete with a user Electronic Serial Number (ESN), WIN identifiers, and routing information such as artist and song title derived from the RBDS/RDS data string accompanying the associated broadcast. In one embodiment, television adapters can use a modem (e.g. a telephone modem, cable modem, etc.) or other network connection to send a purchase request. The purchase request and routing information can then be directed to an APS server 360 for processing, billing approval, and delivery of the content to a particular location (such as the user's flash card or storage technology in the television adapter 300 or a personal account web URL), as requested by the user. In one embodiment, the purchased material is delivered with traditional mail or parcel services.

The flash card or storage technology 320 in the television adapter offers the user a second option. The user can select content for purchase using the interactive voice technologies 314 or the button interface 312 to select broadcast content for purchase. If

that user does not have a network connection, then the content selections can be stored on the flash card or storage technology 320 for later use.

User access to the APS is provided by the remote control, voice interaction or buttons on the actual TV. As a user views broadcast content, the user can respond to the television broadcast to make purchases, respond to an advertisement, to qualify for
5 premiums, or the user can respond to pledge drives on public television or an interactive event such as a talk or game show.

In one embodiment, the user responses are provided to a computing device such as a personal computer, set-top box, and the like (e.g., via flash card or other removable
10 storage medium, via a network connection between the computer and the TET, via a wireless connection such as BlueTooth, etc.). The computing device is then used to transfer the content in a manner similar to that described in the radio embodiment above.

In one embodiment, a cable connection from the TET to the computing device is used for immediate transfer of the user response. In one embodiment, data is transferred
15 between the TET and the computing device using a communication port such as, for example, a serial port, a USB port, infrared port, a parallel port, and Ethernet port, or other port technology.

In one embodiment, the APS module also provides web-enabled cable or satellite television interactive services. In one embodiment, a modem (such as ,for
20 example, a cable modem) is included in the TET thereby allowing the TET to send a user response request directly to a content provider (such as a cable company). In one embodiment, the APS module is provided in a cable set-top box to allow the APS system to be used with a conventional television.

The mechanisms for routing, customer identification, security, tracking, and purchase used with the radio embodiments described above can also be used with the
25 TET.

It is understood that the download server, purchase database server, audio database server and encoding server can reside on one or more computers, and that the
30 shown organization of the servers is for clarification. One or more programs can be used to perform part or all of the functions described in this description.

FOR "SEE" 560

The foregoing description of a preferred implementation has been presented by way of example only, and should not be read in a limiting sense. Although this invention has been described in terms of certain preferred embodiments, other embodiments that are apparent to those of ordinary skill in the art, including embodiments which do not provide all of the benefits and features set forth herein, are also within the scope of this invention. Accordingly, the scope of the present invention is defined only by reference to the appended claims.

5

FOR FURTHER INFORMATION SEE 5660

Sub
AI

WHAT IS CLAIMED IS:

1. A system for performing a transaction based on data provided as part of a broadcast signal, comprising:

5

a broadcast receiver circuit that extracts a RBDS data signal from a broadcast channel, said broadcast channel comprising an audio stream and a RBDS data stream that identifies program material in the audio stream;

a display capable of displaying information corresponding to the data signal;

10

a user input control that allows a user to select a transaction from the displayed information; and

an output device that provides a transaction request comprising an identity of a user and an identification of the selected transaction, said transaction request being provided to a response authentication system.

15

2. The system as in Claim 1, wherein the displayed information identifies a media file available for purchase.

3. The system as in Claim 2, further comprising an input to receive the purchased audio.

4. The system as in Claim 3, wherein the input is a wireless network connection.

20

5. The system as in Claim 1, wherein the output device is a removable memory device.

6. The system as in Claim 1, wherein the output device is a serial data port.

7. The system as in Claim 1, wherein the output device is a parallel data port.

25

8. The system as in Claim 1, wherein the output device is a wireless transmitter.

9. A system for responding to a data stream sent in combination with a media stream on a radio broadcast signal, comprising:

30

a broadcast receiver circuit that detects the radio broadcast signal and extracts a data signal from the data stream, at least a portion of the data signal configured to identify program content in said media stream;

memory for storing the data signal;

FOET60"SEES60

a display for displaying information corresponding to the data signal;
a user input control that allows a user to initiate a purchase request corresponding to the data signal;
a transmitter that transmits the purchase request to a response authentication system; and
a media download device for receiving media corresponding to said purchase request over a communications network.

5

media down
load device

10. The system as in Claim 9, wherein said user input control is a button.

10

11. The system as in Claim 9, wherein said user input control is a voice command device.

12. The system as in Claim 9, wherein the data stream conforms to the Radio Broadcast Data System Standard.

13. The system as in Claim 9, wherein the data stream conforms to the Radio Data Service Standard.

15

14. The system as in Claim 9, wherein the transmitter uses a wireless connection.

15. The system as in Claim 9, wherein the transmitter uses an interface with a computer.

20

16. A response authentication system for processing requests sent in response to a data stream embedded within a broadcast radio signal, comprising:

a database that contains customer information;

a database that correlates a data stream identifier code with a location of the data stream on a communications network;

table?

25

a server that correlates the receipt of a request for a specified data stream with information contained in the data stream location database, the request generated by user response to the broadcast radio signal having a program portion and a data portion, said data portion identifying said program portion; and

30

an order fulfillment server that receives communication of customer information.

17. The system as in Claim 16, wherein a completed order results in a download of a file corresponding to the specified data stream.

18. The system of Claim 16, wherein the data stream identifier code is extracted from identification information stored on a compact disc.

5 19. A method of providing a response to a data stream embedded within a broadcast channel, comprising the steps of:

extracting a digital data signal from a radio broadcast signal that comprises a modulated digital signal stream and a modulated analog signal stream;

10 demodulating the modulated analog signal stream and playing the demodulated analog signal stream;

displaying the digital data in a format that allows a user to identify and scroll through the contents of the digital data signal; and

15 transmitting a selection chosen from the displayed digital data by the user.

20. A method of receiving responses to an audio broadcast, comprising:

20 broadcasting a signal comprising an audio signal and an accompanying identifying data signal, where the data signal identifies the audio signal, wherein the data signal is broadcast in a format that allows a receiver to display to a user information about the audio signal;

receiving a response from a user that identifies the user and the audio signal that the user is responding to;

25 verifying the user identification and the availability of the audio signal; and

acting on the user response.

21. The method of Claim 20, wherein said acting on the user response comprises sending a media file.

22. The method of Claim 20, wherein said acting on the user response comprises transacting a donation.

30 23. The method of Claim 20, wherein said acting on the user response comprises sending a plurality of media files

*DA
in spec*

TO ETTOR SEER

24. A system for performing a transaction based on data provided as part of a broadcast signal, comprising:

5 a broadcast receiver circuit that extracts a data signal from a broadcast signal, said broadcast signal comprising an audio stream, a video stream and a data stream;

a display driver capable of displaying on a television screen information corresponding to the data signal;

a user input control that allows a user to select a transaction from the displayed information;

10 an output device that provides a transaction request comprising an identity of a user and an identification of the selected transaction, said transaction request being provided to a response authentication system.

25. A system for performing a transaction based on data provided as part of a broadcast signal, comprising:

15 a broadcast receiver circuit that extracts a data signal from a broadcast radio-frequency signal, said broadcast signal comprising an audio stream and a data stream;

a user input control that allows a user to initiate a transaction based on the audio stream content;

20 an output device that provides a transaction request comprising an identity of a user and an identification of the selected transaction, said transaction request being provided to a response authentication system.

26. A system for performing a transaction based on data provided as part of a broadcast radio-frequency signal, comprising:

25 a means for extracting a data signal from a broadcast channel, said broadcast channel comprising an audio stream and a data stream that identifies program material in the audio stream;

a means for displaying information corresponding to the data signal;

30 a means for allowing a user to select a transaction from the displayed information;

FOR THE "SECRET"

AT
10/2

a means for requesting a transaction, said transaction request comprising an identity of a user and an identification of the selected transaction, said transaction request being provided to a response authentication system.

FOR THE "SEE 560"

Abstract of the Disclosure

An Automatic Purchase System (APS) provides a radio broadcast listener with the ability to conveniently purchase media content such as music or speech while listening to the radio. The user can respond to items in the radio broadcast such as advertisements, fund raising drives such as those conducted by public radio, or interactive listener polls during the broadcast. Data such as song title and artist, author or publisher and the IP address for the location where the digital version of the content is stored, can be transmitted using the RBDS/RDS data stream. A reference number representing song title and artist, author or publisher and the IP address for the location where the digital version of the content is stored can also be employed for ease of implementation. This reference number can reside in a lookup table to be accessed by the APS server software on a Data Server located at the broadcast site, a remote site or both for purposes of redundancy. Transmission of purchase requests from a Technology Enabled Radio (TER) is provided via wireless transmission, or by accessing the Internet using a personal computer or through a cellular or wireless phone.

H:\DOCS\PDOPDO-1078.DOC
091201

091201 "SECRET"



UNITED STATES PATENT AND TRADEMARK OFFICE

COMMISSIONER FOR PATENTS
 UNITED STATES PATENT AND TRADEMARK OFFICE
 WASHINGTON, D.C. 20231
 www.uspto.gov



Bib Data Sheet

CONFIRMATION NO. 4917

| | | | | | |
|---|---|---|-------------------------------|--|--------------------------------|
| SERIAL NUMBER 09/953,335 | FILING DATE 09/13/2001 RULE | CLASS 455 | GROUP ART UNIT 2681 | ATTORNEY DOCKET NO. STRATOS.001A | |
| APPLICANTS Kelly M. Christensen, Alhambra, CA; Barry D. Thomas, West Hills, CA; Thomas J. Smyth, North Hollywood, CA; | | | | | |
| ** CONTINUING DATA ***** THIS APPLN CLAIMS BENEFIT OF 60/232,333 09/13/2000 | | | | | |
| ** FOREIGN APPLICATIONS ***** | | | | | |
| IF REQUIRED, FOREIGN FILING LICENSE GRANTED ** 10/12/2001 | | | | | |
| Foreign Priority claimed 35 USC 119 (a-d) conditions met | <input type="checkbox"/> yes <input type="checkbox"/> no <input type="checkbox"/> yes <input type="checkbox"/> no <input type="checkbox"/> Met after Allowance | STATE OR COUNTRY CA | SHEETS DRAWING 6 | TOTAL CLAIMS 26 | INDEPENDENT CLAIMS 8 |
| Verified and Acknowledged Examiner's Signature _____ Initials _____ | | | | | |
| ADDRESS 20995 | | | | | |
| TITLE System and method for ordering and delivering media content | | | | | |
| FILING FEE RECEIVED 1398 | FEES: Authority has been given in Paper No. _____ to charge/credit DEPOSIT ACCOUNT No. _____ for following: | <input type="checkbox"/> All Fees <input type="checkbox"/> 1.16 Fees (Filing) <input type="checkbox"/> 1.17 Fees (Processing Ext. of time) <input type="checkbox"/> 1.18 Fees (Issue) <input type="checkbox"/> Other _____ <input type="checkbox"/> Credit | | | |

PATENT APPLICATION FEE DETERMINATION RECORD

Effective October 1, 2000

Application or Docket Number

CLAIMS AS FILED - PART I

| | (Column 1) | (Column 2) |
|---|---------------|--------------|
| TOTAL CLAIMS | 26 | |
| FOR | NUMBER FILED | NUMBER EXTRA |
| TOTAL CHARGEABLE CLAIMS | 26 minus 20 = | * 6 |
| INDEPENDENT CLAIMS | 8 minus 3 = | * 5 |
| MULTIPLE DEPENDENT CLAIM PRESENT <input type="checkbox"/> | | |

* If the difference in column 1 is less than zero, enter "0" in column 2

CLAIMS AS AMENDED - PART II

| | (Column 1) | (Column 2) | (Column 3) | | |
|---|----------------------------------|------------|------------------------------------|---------------|---|
| AMENDMENT A | | | | | |
| | CLAIMS REMAINING AFTER AMENDMENT | | HIGHEST NUMBER PREVIOUSLY PAID FOR | PRESENT EXTRA | |
| | Total | * | Minus | ** | = |
| | Independent | * | Minus | *** | = |
| FIRST PRESENTATION OF MULTIPLE DEPENDENT CLAIM <input type="checkbox"/> | | | | | |

| | (Column 1) | (Column 2) | (Column 3) | | |
|---|----------------------------------|------------|------------------------------------|---------------|---|
| AMENDMENT B | | | | | |
| | CLAIMS REMAINING AFTER AMENDMENT | | HIGHEST NUMBER PREVIOUSLY PAID FOR | PRESENT EXTRA | |
| | Total | * | Minus | ** | = |
| | Independent | * | Minus | *** | = |
| FIRST PRESENTATION OF MULTIPLE DEPENDENT CLAIM <input type="checkbox"/> | | | | | |

| | (Column 1) | (Column 2) | (Column 3) | | |
|---|----------------------------------|------------|------------------------------------|---------------|---|
| AMENDMENT C | | | | | |
| | CLAIMS REMAINING AFTER AMENDMENT | | HIGHEST NUMBER PREVIOUSLY PAID FOR | PRESENT EXTRA | |
| | Total | * | Minus | ** | = |
| | Independent | * | Minus | *** | = |
| FIRST PRESENTATION OF MULTIPLE DEPENDENT CLAIM <input type="checkbox"/> | | | | | |

* If the entry in column 1 is less than the entry in column 2, write "0" in column 3.
 ** If the "Highest Number Previously Paid For" IN THIS SPACE is less than 20, enter "20."
 *** If the "Highest Number Previously Paid For" IN THIS SPACE is less than 3, enter "3."
 The "Highest Number Previously Paid For" (Total or Independent) is the highest number found in the appropriate box in column 1.

SMALL ENTITY TYPE

OR OTHER THAN SMALL ENTITY

| RATE | FEE |
|-----------|--------|
| BASIC FEE | 355.00 |
| X\$ 9= | |
| X40= | |
| +135= | |
| TOTAL | |

| RATE | FEE |
|-----------|---------|
| BASIC FEE | 710.00 |
| X\$18= | 108.00 |
| X80= | 400.00 |
| +270= | |
| TOTAL | 1218.00 |

SMALL ENTITY

OR OTHER THAN SMALL ENTITY

| RATE | ADDITIONAL FEE |
|------------------|----------------|
| X\$ 9= | |
| X40= | |
| +135= | |
| TOTAL ADDIT. FEE | |

| RATE | ADDITIONAL FEE |
|------------------|----------------|
| X\$18= | |
| X80= | |
| +270= | |
| TOTAL ADDIT. FEE | |

| RATE | ADDITIONAL FEE |
|------------------|----------------|
| X\$ 9= | |
| X40= | |
| +135= | |
| TOTAL ADDIT. FEE | |

| RATE | ADDITIONAL FEE |
|------------------|----------------|
| X\$18= | |
| X80= | |
| +270= | |
| TOTAL ADDIT. FEE | |

| RATE | ADDITIONAL FEE |
|------------------|----------------|
| X\$ 9= | |
| X40= | |
| +135= | |
| TOTAL ADDIT. FEE | |

| RATE | ADDITIONAL FEE |
|------------------|----------------|
| X\$18= | |
| X80= | |
| +270= | |
| TOTAL ADDIT. FEE | |

CLAIMS ONLY

SERIAL NO.

FILING DATE

APPLICANT(S)

CLAIMS

| | AS FILED | | AFTER 1st AMENDMENT | | AFTER 2nd AMENDMENT | |
|--------------|----------|------|---------------------|------|---------------------|------|
| | IND. | DEP. | IND. | DEP. | IND. | DEP. |
| 1 | | | | | | |
| 2 | | | | | | |
| 3 | | | | | | |
| 4 | | | | | | |
| 5 | | | | | | |
| 6 | | | | | | |
| 7 | | | | | | |
| 8 | | | | | | |
| 9 | | | | | | |
| 10 | | | | | | |
| 11 | | | | | | |
| 12 | | | | | | |
| 13 | | | | | | |
| 14 | | | | | | |
| 15 | | | | | | |
| 16 | | | | | | |
| 17 | | | | | | |
| 18 | | | | | | |
| 19 | | | | | | |
| 20 | | | | | | |
| 21 | | | | | | |
| 22 | | | | | | |
| 23 | | | | | | |
| 24 | | | | | | |
| 25 | | | | | | |
| 26 | | | | | | |
| 27 | | | | | | |
| 28 | | | | | | |
| 29 | | | | | | |
| 30 | | | | | | |
| 31 | | | | | | |
| 32 | | | | | | |
| 33 | | | | | | |
| 34 | | | | | | |
| 35 | | | | | | |
| 36 | | | | | | |
| 37 | | | | | | |
| 38 | | | | | | |
| 39 | | | | | | |
| 40 | | | | | | |
| 41 | | | | | | |
| 42 | | | | | | |
| 43 | | | | | | |
| 44 | | | | | | |
| 45 | | | | | | |
| 46 | | | | | | |
| 47 | | | | | | |
| 48 | | | | | | |
| 49 | | | | | | |
| 50 | | | | | | |
| TOTAL IND. | 8 | | | | | |
| TOTAL DEP. | 18 | | | | | |
| TOTAL CLAIMS | 26 | | | | | |

| | * | | * | | * | |
|--------------|------|------|------|------|------|------|
| | IND. | DEP. | IND. | DEP. | IND. | DEP. |
| 51 | | | | | | |
| 52 | | | | | | |
| 53 | | | | | | |
| 54 | | | | | | |
| 55 | | | | | | |
| 56 | | | | | | |
| 57 | | | | | | |
| 58 | | | | | | |
| 59 | | | | | | |
| 60 | | | | | | |
| 61 | | | | | | |
| 62 | | | | | | |
| 63 | | | | | | |
| 64 | | | | | | |
| 65 | | | | | | |
| 66 | | | | | | |
| 67 | | | | | | |
| 68 | | | | | | |
| 69 | | | | | | |
| 70 | | | | | | |
| 71 | | | | | | |
| 72 | | | | | | |
| 73 | | | | | | |
| 74 | | | | | | |
| 75 | | | | | | |
| 76 | | | | | | |
| 77 | | | | | | |
| 78 | | | | | | |
| 79 | | | | | | |
| 80 | | | | | | |
| 81 | | | | | | |
| 82 | | | | | | |
| 83 | | | | | | |
| 84 | | | | | | |
| 85 | | | | | | |
| 86 | | | | | | |
| 87 | | | | | | |
| 88 | | | | | | |
| 89 | | | | | | |
| 90 | | | | | | |
| 91 | | | | | | |
| 92 | | | | | | |
| 93 | | | | | | |
| 94 | | | | | | |
| 95 | | | | | | |
| 96 | | | | | | |
| 97 | | | | | | |
| 98 | | | | | | |
| 99 | | | | | | |
| 100 | | | | | | |
| TOTAL IND. | | | | | | |
| TOTAL DEP. | | | | | | |
| TOTAL CLAIMS | | | | | | |

* MAY BE USED FOR ADDITIONAL CLAIMS OR ADMEENDMENTS

2



UNITED STATES PATENT AND TRADEMARK OFFICE

COMMISSIONER FOR PATENTS
 UNITED STATES PATENT AND TRADEMARK OFFICE
 WASHINGTON, D.C. 20231
 www.uspto.gov

| APPLICATION NUMBER | FILING/RECEIPT DATE | FIRST NAMED APPLICANT | ATTORNEY DOCKET NUMBER |
|--------------------|---------------------|-----------------------|------------------------|
| 09/953,335 | 09/13/2001 | Kelly M. Christensen | STRATOS.001A |

CONFIRMATION NO. 4917

20995
 KNOBBE MARTENS OLSON & BEAR LLP
 620 NEWPORT CENTER DRIVE
 SIXTEENTH FLOOR
 NEWPORT BEACH, CA 92660

FORMALITIES LETTER



OC00000006899747

Date Mailed: 10/12/2001

NOTICE TO FILE MISSING PARTS OF NONPROVISIONAL APPLICATION

FILED UNDER 37 CFR 1.53(b)

Filing Date Granted

An application number and filing date have been accorded to this application. The item(s) indicated below, however, are missing. Applicant is given **TWO MONTHS** from the date of this Notice within which to file all required items and pay any fees required below to avoid abandonment. Extensions of time may be obtained by filing a petition accompanied by the extension fee under the provisions of 37 CFR 1.136(a).

- The statutory basic filing fee is missing.
Applicant must submit \$ 710 to complete the basic filing fee for a non-small entity. If appropriate, applicant may make a written assertion of entitlement to small entity status and pay the small entity filing fee (37 CFR 1.27).
- Total additional claim fee(s) for this application is \$508.
 - \$108 for 6 total claims over 20.
 - \$400 for 5 independent claims over 3 .
- The oath or declaration is missing.
A properly signed oath or declaration in compliance with 37 CFR 1.63, identifying the application by the above Application Number and Filing Date, is required.
- To avoid abandonment, a late filing fee or oath or declaration surcharge as set forth in 37 CFR 1.16(l) of \$130 for a non-small entity, must be submitted with the missing items identified in this letter.
- **The balance due by applicant is \$ 1348.**

The application is informal since it does not comply with the regulations for the reason(s) indicated below.

The required item(s) identified below must be timely submitted to avoid abandonment:

- Substitute drawings in compliance with 37 CFR 1.84 because:
 - drawing sheets do not have the appropriate margin(s) (see 37 CFR 1.84(g)). Each sheet must include a top margin of at least 2.5 cm. (1 inch), a left side margin of at least 2.5 cm. (1 inch), a right side margin of at least 1.5 cm. (5/8 inch), and a bottom margin of at least 1.0 cm. (3/8 inch);

A copy of this notice MUST be returned with the reply.

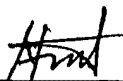

Customer Service Center
Initial Patent Examination Division (703) 308-1202

PART 3 - OFFICE COPY

PATENT

Section #318

Case Docket No. STRATOS.001A

Date: December 12, 2001

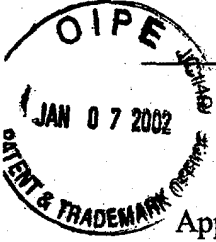

IN THE UNITED STATES PATENT AND TRADEMARK OFFICE

Applicant(s) : Christensen, et al.
App. No. : 09/953,335
Filed : September 13, 2001
For : SYSTEM AND METHOD FOR ORDERING AND DELIVERING MEDIA CONTENT

I hereby certify that this correspondence and all marked attachments are being deposited with the United States Postal Service as first class mail in an envelope addressed to: Assistant Commissioner for Patents, Washington, D.C. 20231, on

December 12, 2001

(Date)

Lee W. Henderson

Lee W. Henderson Ph.D., Reg. No. 41,830

Group Art Unit : 2681

TRANSMITTAL LETTER

ASSISTANT COMMISSIONER FOR PATENTS
WASHINGTON, D.C. 20231

ATTENTION: BOX MISSING PARTS

Dear Sir:

In response to the Notice to File Missing Parts of Application Under 37 CFR 1.53(f), which was mailed by the Office on October 12, 2001, enclosed are:

- (X) A Declaration and Power of Attorney.
- (X) A Power of Attorney Form and Copy of Assignment.
- (X) 6 Sheets of Drawings.
- (X) A Notice to File Missing Parts.
- (X) Return prepaid postcard.
- (X) Fees as calculated below:

PATENT

Case Docket No. STRATOS.001A

Date: December 12, 2001

| | | |
|---|--------|---------|
| FILING FEE | | \$ 740 |
| FEE FOR 6 TOTAL CLAIMS OVER 20 | | \$ 108 |
| FEE FOR 5 INDEPENDENT CLAIMS OVER 3 | | \$ 400 |
| FEE FOR EXTENSION OF TIME (LARGE ENTITY) | months | \$ 0 |
| SURCHARGE 37 CFR 1.16(e) | | \$ +130 |
| TOTAL OF ABOVE CALCULATIONS | | \$ 1378 |
| REDUCTION BY 1/2 FOR FILING BY SMALL ENTITY. | | |
| Note 37 CFR 1.9, 1.27, 1.28. If applicable, verified statement must be attached. \$ - N/A | | |
| TOTAL FEES SUBMITTED HEREWITH | | \$ 1398 |

- (X) A check in the amount of \$1398.00 to cover the above fees is enclosed.
- (X) The Commissioner is hereby authorized to charge any additional fees which may be required, now or in the future, or credit any overpayment, to Account No. 11-1410.

Lee W Henderson

Lee W. Henderson Ph.D.
Registration No. 41,830
Attorney of Record

H:\DOCS\LWHLWH-6522.DOC:jk
121101



UNITED STATES PATENT AND TRADEMARK OFFICE

COMMISSIONER FOR PATENTS
UNITED STATES PATENT AND TRADEMARK OFFICE
WASHINGTON, D.C. 20231
www.uspto.gov

JAN 7 2002
Cus
Initi
95

| APPLICATION NUMBER | FILING/RECEIPT DATE | FIRST NAMED APPLICANT | ATTORNEY DOCKET NUMBER |
|--------------------|---------------------|-----------------------|------------------------|
| 09/953,335 | 09/13/2001 | Kelly M. Christensen | STRATOS.001A |

CONFIRMATION NO. 4917

FORMALITIES LETTER



0C00000006899747

OBBE'S OLSON & BEAR LLP
TER DRIVE

192660

Date Mailed: 10/12/2001

NOTICE TO FILE MISSING PARTS OF NONPROVISIONAL APPLICATION

BABRAHA1 00000047 09953335

FILED UNDER 37 CFR 1.53(b)

740.00 OP
130.00 OP
108.00 OP
420.00 OP

Filing Date Granted

FC:104
FC:105
FC:106
FC:107

An application number and filing date have been accorded to this application. The item(s) indicated below, however, are missing. Applicant is given **TWO MONTHS** from the date of this Notice within which to file all required items and pay any fees required below to avoid abandonment. Extensions of time may be obtained by filing a petition accompanied by the extension fee under the provisions of 37 CFR 1.136(a).

- The statutory basic filing fee is missing.
Applicant must submit \$ 710 to complete the basic filing fee for a non-small entity. If appropriate, applicant may make a written assertion of entitlement to small entity status and pay the small entity filing fee (37 CFR 1.27).
- Total additional claim fee(s) for this application is \$508.
 - \$108 for 6 total claims over 20.
 - \$400 for 5 independent claims over 3 .
- The oath or declaration is missing.
A properly signed oath or declaration in compliance with 37 CFR 1.63, identifying the application by the above Application Number and Filing Date, is required.
- To avoid abandonment, a late filing fee or oath or declaration surcharge as set forth in 37 CFR 1.16(l) of \$130 for a non-small entity, must be submitted with the missing items identified in this letter.
- **The balance due by applicant is \$ 1348.**

The application is informal since it does not comply with the regulations for the reason(s) indicated below.

The required item(s) identified below must be timely submitted to avoid abandonment:

- Substitute drawings in compliance with 37 CFR 1.84 because:
 - drawing sheets do not have the appropriate margin(s) (see 37 CFR 1.84(g)). Each sheet must include a top margin of at least 2.5 cm. (1 inch), a left side margin of at least 2.5 cm. (1 inch), a right side margin of at least 1.5 cm. (5/8 inch), and a bottom margin of at least 1.0 cm. (3/8 inch);

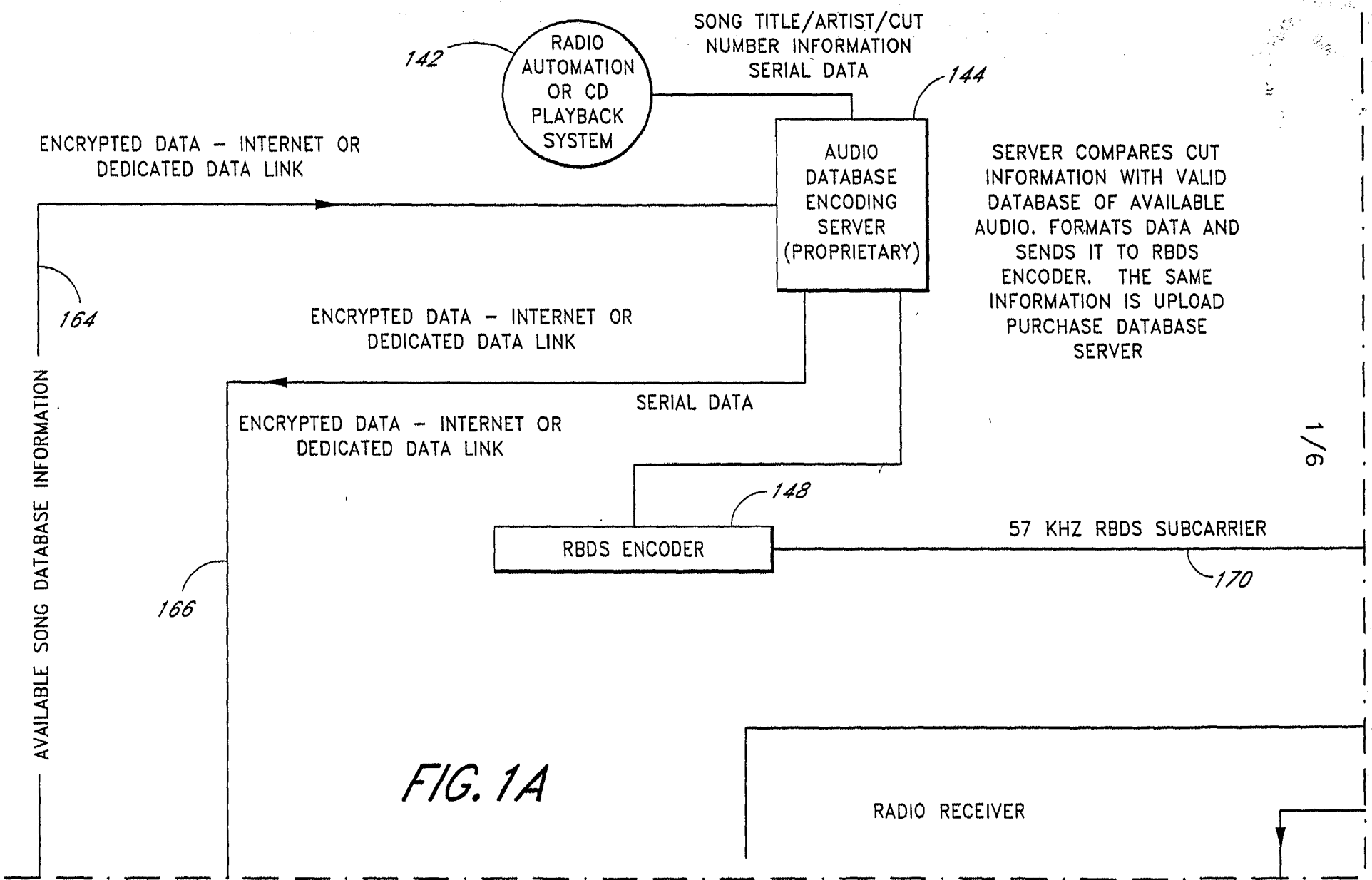
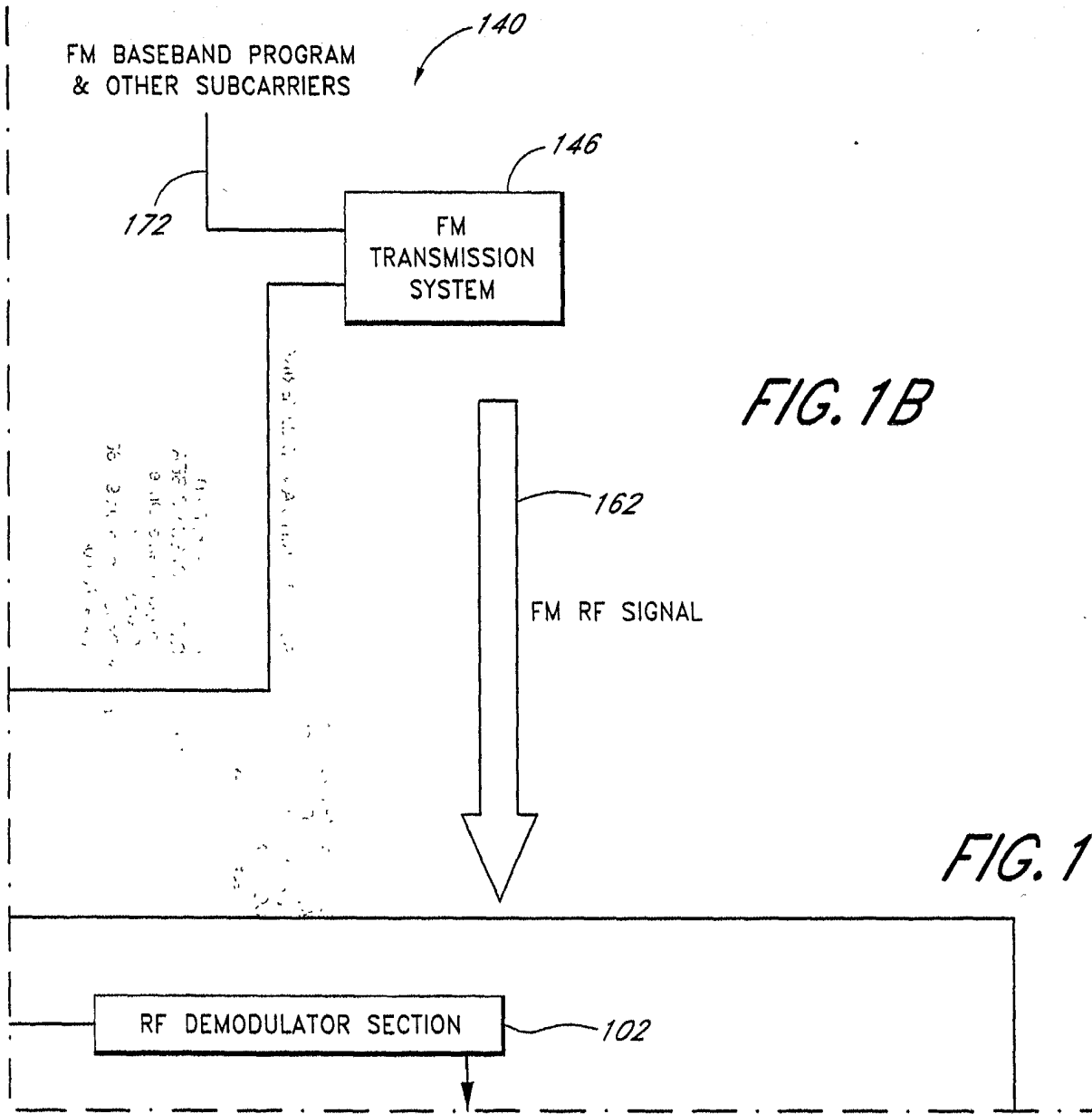
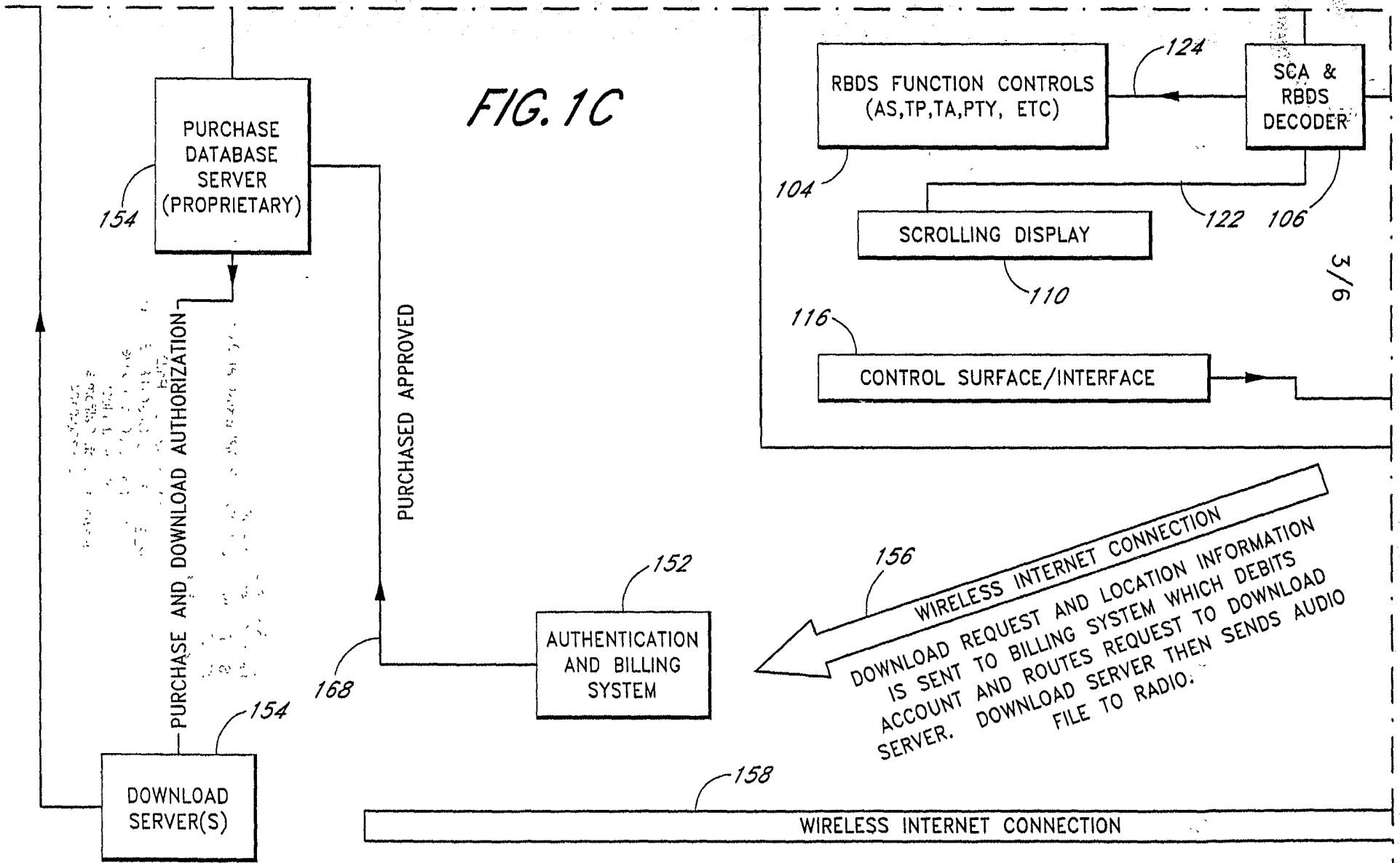

FIG. 1A

1/6



| | |
|---------|---------|
| FIG. 1A | FIG. 1B |
| FIG. 1C | FIG. 1D |



WIRELESS INTERNET CONNECTION
DOWNLOADED REQUEST AND LOCATION INFORMATION
IS SENT TO BILLING SYSTEM WHICH DEBITS
ACCOUNT AND ROUTES REQUEST TO DOWNLOAD
SERVER. DOWNLOAD SERVER THEN SENDS AUDIO
FILE TO RADIO.

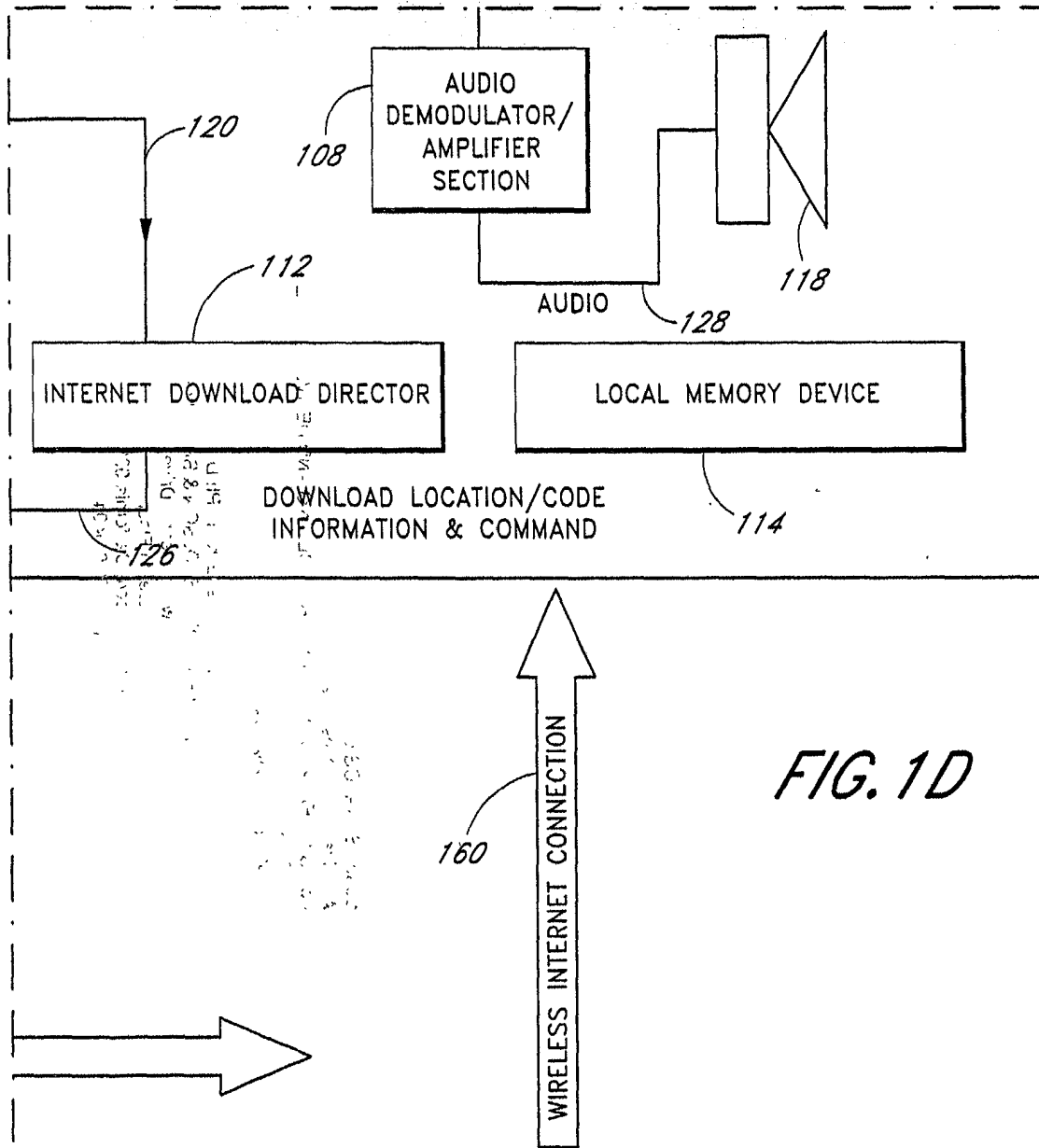

FIG. 1D



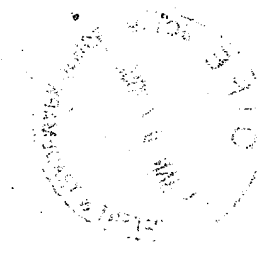
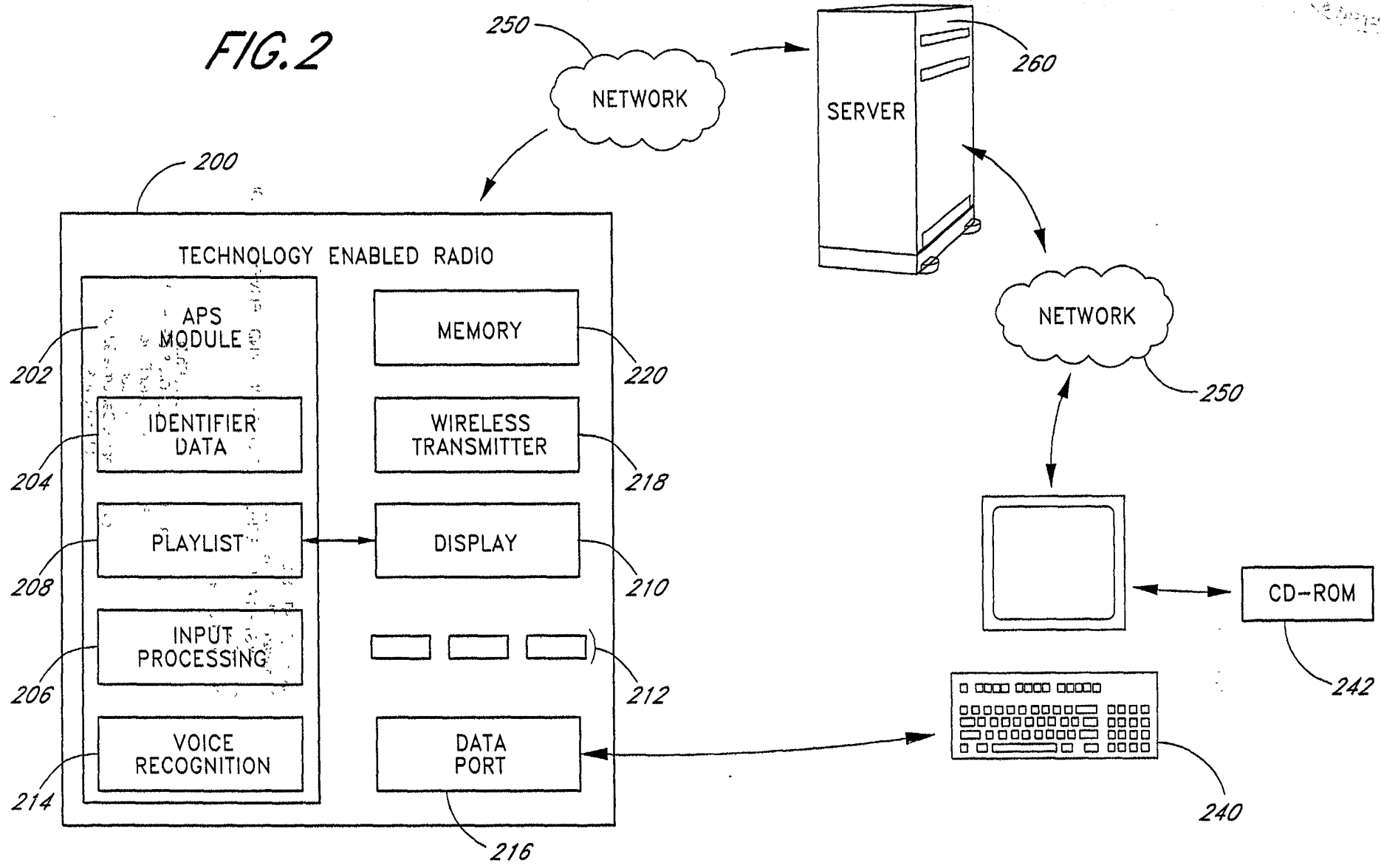

FIG. 2



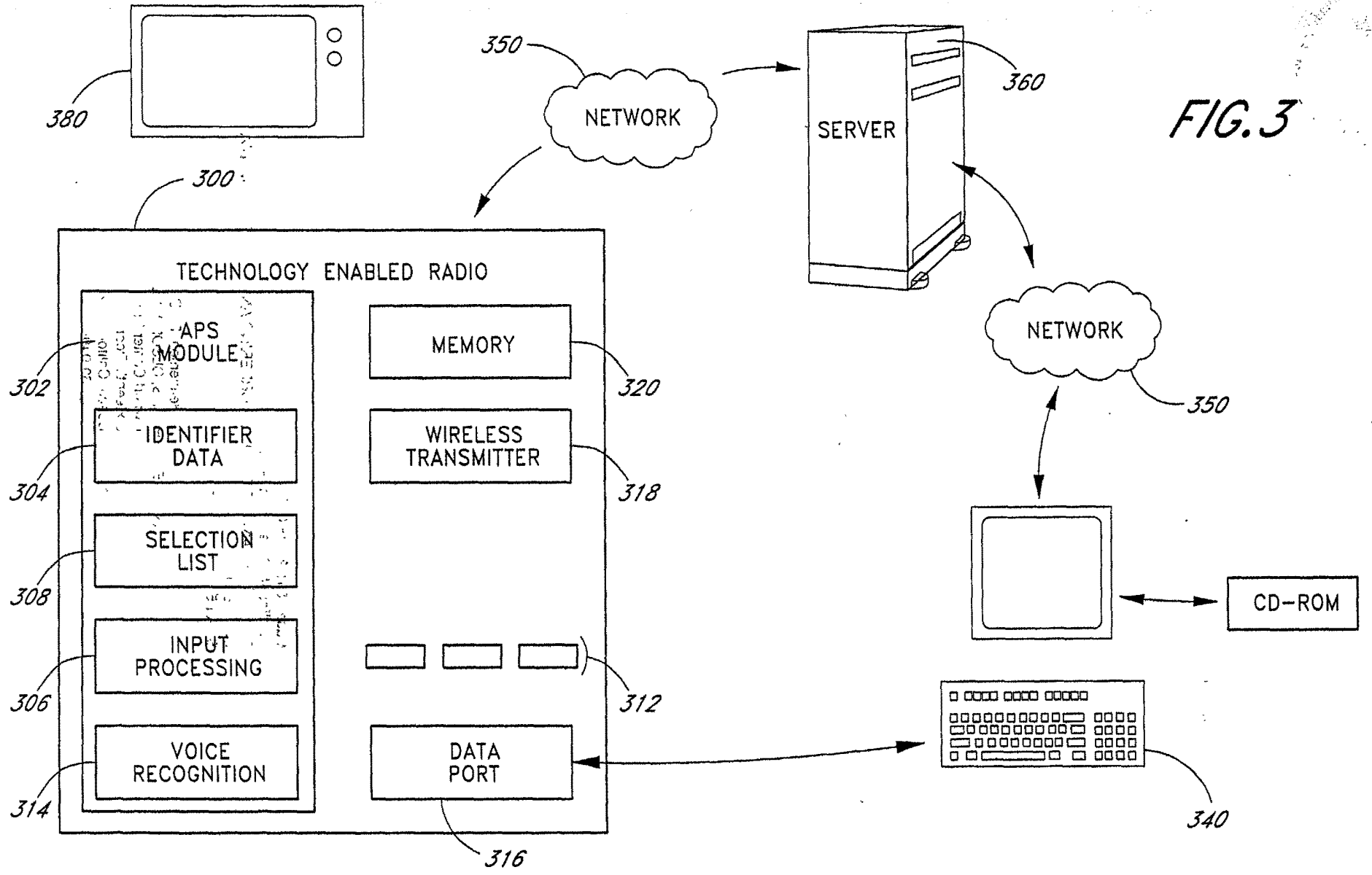

FIG. 3

9/9

W



DECLARATION AND POWER OF ATTORNEY- USA PATENT APPLICATION

As a below named inventor, I hereby declare that:

My residence, post office address and citizenship are as stated below next to my name;

I believe I am an original, first and joint inventor of the subject matter which is claimed and for which a patent is sought on the invention entitled **SYSTEM AND METHOD FOR ORDERING AND DELIVERING MEDIA CONTENT**; the specification of which was filed on **September 13, 2001** as Application Serial No. **09/953,335**.

I hereby state that I have reviewed and understand the contents of the above identified specification, including the claims, as amended by any amendment referred to above;

I acknowledge the duty to disclose information which is material to patentability as defined in Title 37, Code of Federal Regulations, § 1.56;

I hereby claim the benefit under Title 35, United States Codes § 119(e) of any United States provisional application(s) listed below.

Application No.: 60/232,333

Filing Date: September 13, 2000

POWER OF ATTORNEY: I hereby appoint the registrants of Knobbe, Martens, Olson & Bear, LLP, 620 Newport Center Drive, Sixteenth Floor, Newport Beach, California 92660, Telephone (949) 760-0404, **Customer No. 20,995**, to prosecute this application and to transact all business in the Patent and Trademark Office connected therewith.

I hereby declare that all statements made herein of my own knowledge are true and that all statements made on information and belief are believed to be true; and further that these statements were made with the knowledge that willful false statements and the like so made are punishable by fine or imprisonment, or both, under Section 1001 of Title 18 of the United States Code and that such willful, false statements may jeopardize the validity of the application or any patent issued thereon.

Full name of first inventor: **Kelly M. Christensen**

Inventor's signature *Kelly M. Christensen*

Date 11-8-01

Residence: **935 N. Dos Robles Avenue, Alhambra, CA 91801**

Citizenship: **United States**

Post Office Address: Same as above.

Full name of second inventor: **Barry D. Thomas**

Inventor's signature Barry D. Thomas

Date 11/8/01

Residence: **23774 Burton Street, West Hills, CA 91304**

Citizenship: **United States**

Post Office Address: Same as above.

Full name of third inventor: **Thomas J. Smyth**

Inventor's signature Thomas J. Smyth

Date 11/8/01

Residence: **10723 Valley Spring Lane, North Hollywood, CA 91602**

Citizenship: **United States**

Post Office Address: Same as above.

Send Correspondence To:
KNOBBE, MARTENS, OLSON & BEAR, LLP
Customer No. 20,995

H:\DOCS\LWHLWH-6437.DOC:jk
110801

STRATOS.001A

PATENT

IN THE UNITED STATES PATENT AND TRADEMARK OFFICE

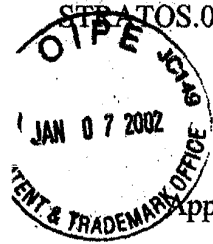

Applicant : Christensen, et al.)
)
 App. No. : 09/953,335)
)
 Filed : September 13, 2001)
)
 For : SYSTEM AND METHOD FOR)
 ORDERING AND DELIVERING)
 MEDIA CONTENT)
)
 Examiner : Unknown)
)

ESTABLISHMENT OF RIGHT OF ASSIGNEE TO TAKE ACTION
AND
REVOCAION AND POWER OF ATTORNEY

Assistant Commissioner for Patents
 Washington, D.C. 20231

Dear Sir:

The undersigned is empowered to act on behalf of the assignee below (the "Assignee"). A true copy of the original Assignment of the above-captioned application from the inventor(s) to the Assignee is attached hereto. This Assignment represents the entire chain of title of this invention from the Inventor(s) to the Assignee.

I declare that all statements made herein are true, and that all statements made upon information and belief are believed to be true, and further, that these statements were made with the knowledge that willful, false statements and the like so made are punishable by fine or imprisonment, or both, under 18 U.S.C. § 1001, and that willful, false statements may jeopardize the validity of the application, or any patent issuing thereon.

The undersigned hereby revokes any previous powers of attorney in the subject application, and hereby appoints the registrants of Knobbe, Martens, Olson & Bear, LLP, 620 Newport Center Drive, Sixteenth Floor, Newport Beach, California 92660, Telephone (949) 760-0404, **Customer No. 20,995**, as its attorneys with full power of substitution and

App. No. : 09/953,335
Filed : September 13, 2001

revocation to prosecute this application and to transact all business in the U.S. Patent and Trademark Office connected herewith. This appointment is to be to the exclusion of the inventor(s) and his attorney(s) in accordance with the provisions of 37 C.F.R. § 3.71.

Please use **Customer No. 20,995** for all communications.

STRATOSAUDIO, INC.

Dated: November 8, 2001

By: Kelley M. Osterman

Title:

Address: **10 Universal City Plaza, Suite 2000
Universal City, CA 91608**

H:\DOCS\LWHLWH-6395.DOC:jk
102601

PLEASE DO NOT REMOVE

#

COPY

Application No.: 09/953,335
Filing Date: September 13, 2001

PATENT
Client Code: STRATOS.001A
Page 1

ASSIGNMENT

WHEREAS, We, Kelly M. Christensen, a United States citizen, residing at 935 N. Dos Robles Avenue, Alhambra, CA 91801; Barry D. Thomas, a United States citizen, residing at 23774 Burton Street, West Hills, CA 91304; and Thomas J. Smyth, a United States citizen, residing at 10723 Valley Spring Lane, North Hollywood, CA 91602, have invented certain new and useful improvements in a SYSTEM AND METHOD FOR ORDERING AND DELIVERING MEDIA CONTENT for which we have filed an application for Letters Patent in the United States, September 13, 2001;

AND WHEREAS, STRATOSAUDIO, INC. (hereinafter "ASSIGNEE"), a Delaware Corporation, with its principal place of business at 10 Universal City Plaza, Suite 2000, Universal City, CA 91608, desires to acquire the entire right, title, and interest in and to the said improvements and the said Application:

NOW, THEREFORE, in consideration of the sum of One Dollar (\$1.00) to me in hand paid, and other good and valuable consideration, the receipt of which is hereby acknowledged, we, the said inventors, do hereby acknowledge that we have sold, assigned, transferred and set over, and by these presents do hereby sell, assign, transfer and set over, unto the said ASSIGNEE, its successors, legal representatives and assigns, the entire right, title, and interest throughout the world in, to and under the said improvements, and the said application and all provisional applications relating thereto, and all divisions, renewals and continuations thereof, and all Letters Patent of the United States which may be granted thereon and all reissues and extensions thereof, and all rights of priority under International Conventions and applications for Letters Patent which may hereafter be filed for said improvements in any country or countries foreign to the United States, and all Letters Patent which may be granted for said improvements in any country or countries foreign to the United States and all extensions, renewals and reissues thereof; and we hereby authorize and request the Commissioner of Patents of the United States, and any Official of any country or countries foreign to the United States, whose duty it is to issue patents on applications as aforesaid, to issue all Letters Patent for said improvements to the said ASSIGNEE, its successors, legal representatives and assigns, in accordance with the terms of this instrument.

AND WE HEREBY covenant and agree that we will communicate to the said ASSIGNEE, its successors, legal representatives and assigns, any facts known to us respecting said improvements, and testify in any legal proceeding, sign all lawful papers, execute all divisional, continuing and reissue applications, make all rightful oaths and generally do everything possible to aid the said ASSIGNEE, its successors, legal representatives and assigns, to obtain and enforce proper patent protection for said improvements in all countries.

IN TESTIMONY WHEREOF, I hereunto set my hand and seal this 8th day of November, 2001

Kelly M. Christensen
Kelly M. Christensen

STATE OF California
COUNTY OF Los Angeles } ss.

On Nov. 8, 2001, before me, Nobuko Christy, a notary public, personally appeared Kelly M. Christensen personally known to me (or proved to me on the basis of satisfactory evidence) to be the person(s) whose name(s) is/are subscribed to the within instrument, and acknowledged to me that he executed the same in his authorized capacity(ies), and that by his signature(s) on the instrument the person(s), or the entity upon behalf of which the person(s) acted, executed the instrument.

WITNESS my hand and official seal.

[SEAL]

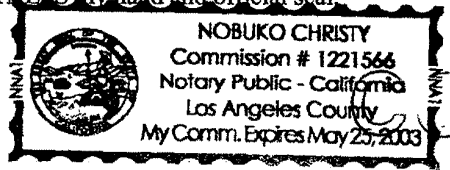

Nobuko Christy

Notary Signature

IN TESTIMONY WHEREOF, I hereunto set my hand and seal this 8 day of November, 2001.

Barry D. Thomas
Barry D. Thomas

STATE OF California
COUNTY OF Los Angeles } ss.

On Nov. 8, 2001, before me, Nobuko Christy, a notary public, personally appeared Barry D. Thomas personally known to me (or proved to me on the basis of satisfactory evidence) to be the person(s) whose name(s) is/are subscribed to the within instrument, and acknowledged to me that he executed the same in his authorized capacity(ies), and that by his signature(s) on the instrument the person(s), or the entity upon behalf of which the person(s) acted, executed the instrument.

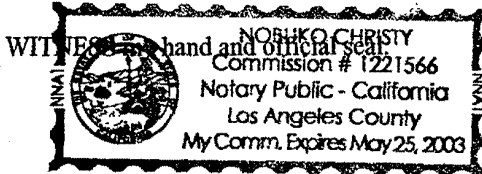

Nobuko Christy
Notary Signature

IN TESTIMONY WHEREOF, I hereunto set my hand and seal this 8th day of NOVEMBER 2001.

Thomas J. Smyth
Thomas J. Smyth

STATE OF California
COUNTY OF Los Angeles } ss.

On Nov. 8, 2001, before me, Nobuko Christy, a notary public, personally appeared Thomas J. Smyth personally known to me (or proved to me on the basis of satisfactory evidence) to be the person(s) whose name(s) is/are subscribed to the within instrument, and acknowledged to me that he executed the same in his authorized capacity(ies), and that by his signature(s) on the instrument the person(s), or the entity upon behalf of which the person(s) acted, executed the instrument.

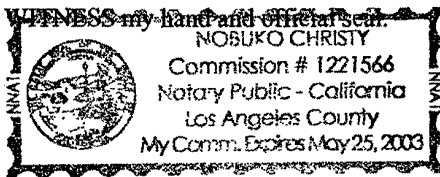

Nobuko Christy
Notary Signature

Section #310

Case Docket No. STRATOS.001A

Date: December 12, 2001



IN THE UNITED STATES PATENT AND TRADEMARK OFFICE

Applicant(s) : Christensen, et al.
App. No. : 09/953,335
Filed : September 13, 2001
For : SYSTEM AND METHOD FOR ORDERING AND DELIVERING MEDIA CONTENT

I hereby certify that this correspondence and all marked attachments are being deposited with the United States Postal Service as first class mail in an envelope addressed to: Assistant Commissioner for Patents, Washington, D.C. 20231, on

December 12, 2001

(Date)

Lee W. Henderson

Lee W. Henderson Ph.D., Reg. No. 41,830

Group Art Unit : 2681

TRANSMITTAL LETTER

ASSISTANT COMMISSIONER FOR PATENTS
WASHINGTON, D.C. 20231

ATTENTION: BOX MISSING PARTS

Dear Sir:

In response to the Notice to File Missing Parts of Application Under 37 CFR 1.53(f), which was mailed by the Office on October 12, 2001, enclosed are:

- (X) A Declaration and Power of Attorney.
- (X) A Power of Attorney Form and Copy of Assignment.
- (X) 6 Sheets of Drawings.
- (X) A Notice to File Missing Parts.
- (X) Return prepaid postcard.
- (X) Fees as calculated below:

20010913

PATENT

Case Docket No. STRATOS.001A

Date: December 12, 2001

| | |
|------------|--------|
| FILING FEE | \$ 740 |
|------------|--------|

| | |
|--------------------------------|--------|
| FEE FOR 6 TOTAL CLAIMS OVER 20 | \$ 108 |
|--------------------------------|--------|

| | |
|-------------------------------------|--------|
| FEE FOR 5 INDEPENDENT CLAIMS OVER 3 | \$ 420 |
|-------------------------------------|--------|

| | |
|---|------|
| FEE FOR EXTENSION OF TIME (LARGE ENTITY) months | \$ 0 |
|---|------|

| | |
|--------------------------|---------|
| SURCHARGE 37 CFR 1.16(e) | \$ +130 |
|--------------------------|---------|

| | |
|-----------------------------|---------|
| TOTAL OF ABOVE CALCULATIONS | \$ 1378 |
|-----------------------------|---------|

REDUCTION BY 1/2 FOR FILING BY SMALL ENTITY.

Note 37 CFR 1.9, 1.27, 1.28. If applicable, verified statement must be attached. \$ - N/A

| | |
|-------------------------------|---------|
| TOTAL FEES SUBMITTED HEREWITH | \$ 1398 |
|-------------------------------|---------|

- (X) A check in the amount of \$1398.00 to cover the above fees is enclosed.
- (X) The Commissioner is hereby authorized to charge any additional fees which may be required, now or in the future, or credit any overpayment, to Account No. 11-1410.



Lee W. Henderson Ph.D.
Registration No. 41,830
Attorney of Record

H:\DOCS\LWHL\WH-6522.DOC:jk
121101



UNITED STATES PATENT AND TRADEMARK OFFICE

COMMISSIONER FOR PATENTS
 UNITED STATES PATENT AND TRADEMARK OFFICE
 WASHINGTON, D.C. 20231
 www.uspto.gov

| APPLICATION NUMBER | FILING/RECEIPT DATE | FIRST NAMED APPLICANT | ATTORNEY DOCKET NUMBER |
|--------------------|---------------------|-----------------------|------------------------|
| 09/953,335 | 09/13/2001 | Kelly M. Christensen | STRATOS.001A |

CONFIRMATION NO. 4917

FORMALITIES LETTER



OC00000000689974

20995
 KNOBBE MARTENS OLSON & BEAR LLP
 620 NEWPORT CENTER DRIVE
 SIXTEENTH FLOOR
 NEWPORT BEACH, CA 92660

Date Mailed: 10/12/2001

NOTICE TO FILE MISSING PARTS OF NONPROVISIONAL APPLICATION

01/11/2002 BABRAHA1 00000047 09953335

FILED UNDER 37 CFR 1.53(b)

| | |
|-----------|-----------|
| 01 FC:101 | 740.00 OP |
| 02 FC:105 | 130.00 OP |
| 03 FC:103 | 108.00 OP |
| 04 FC:102 | 420.00 OP |

Filing Date Granted

An application number and filing date have been accorded to this application. The item(s) indicated below, however, are missing. Applicant is given **TWO MONTHS** from the date of this Notice within which to file all required items and pay any fees required below to avoid abandonment. Extensions of time may be obtained by filing a petition accompanied by the extension fee under the provisions of 37 CFR 1.136(a).

- The statutory basic filing fee is missing.
Applicant must submit \$ 710 to complete the basic filing fee for a non-small entity. If appropriate, applicant may make a written assertion of entitlement to small entity status and pay the small entity filing fee (37 CFR 1.27).
- Total additional claim fee(s) for this application is \$508.
 - \$108 for 6 total claims over 20.
 - \$400 for 5 independent claims over 3 .
- The oath or declaration is missing.
A properly signed oath or declaration in compliance with 37 CFR 1.63, identifying the application by the above Application Number and Filing Date, is required.
- To avoid abandonment, a late filing fee or oath or declaration surcharge as set forth in 37 CFR 1.16(l) of \$130 for a non-small entity, must be submitted with the missing items identified in this letter.
- **The balance due by applicant is \$ 1348.**

The application is informal since it does not comply with the regulations for the reason(s) indicated below.

The required item(s) identified below must be timely submitted to avoid abandonment:

- Substitute drawings in compliance with 37 CFR 1.84 because:
 - drawing sheets do not have the appropriate margin(s) (see 37 CFR 1.84(g)). Each sheet must include a top margin of at least 2.5 cm. (1 inch), a left side margin of at least 2.5 cm. (1 inch), a right side margin of at least 1.5 cm. (5/8 inch), and a bottom margin of at least 1.0 cm. (3/8 inch);

A copy of this notice MUST be returned with the reply.

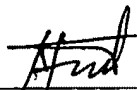

Customer Service Center

Initial Patent Examination Division (703) 308-1202

PART 2 - COPY TO BE RETURNED WITH RESPONSE

TS

DECLARATION AND POWER OF ATTORNEY- USA PATENT APPLICATION



As a below named inventor, I hereby declare that:

My residence, post office address and citizenship are as stated below next to my name;

I believe I am an original, first and joint inventor of the subject matter which is claimed and for which a patent is sought on the invention entitled **SYSTEM AND METHOD FOR ORDERING AND DELIVERING MEDIA CONTENT**; the specification of which was filed on **September 13, 2001** as Application Serial No. **09/953,335**.

I hereby state that I have reviewed and understand the contents of the above identified specification, including the claims, as amended by any amendment referred to above;

I acknowledge the duty to disclose information which is material to patentability as defined in Title 37, Code of Federal Regulations, § 1.56;

I hereby claim the benefit under Title 35, United States Codes § 119(e) of any United States provisional application(s) listed below.

Application No.: 60/232,333

Filing Date: September 13, 2000

POWER OF ATTORNEY: I hereby appoint the registrants of Knobbe, Martens, Olson & Bear, LLP, 620 Newport Center Drive, Sixteenth Floor, Newport Beach, California 92660, Telephone (949) 760-0404, **Customer No. 20,995**, to prosecute this application and to transact all business in the Patent and Trademark Office connected therewith.

I hereby declare that all statements made herein of my own knowledge are true and that all statements made on information and belief are believed to be true; and further that these statements were made with the knowledge that willful false statements and the like so made are punishable by fine or imprisonment, or both, under Section 1001 of Title 18 of the United States Code and that such willful, false statements may jeopardize the validity of the application or any patent issued thereon.

Full name of first inventor: **Kelly M. Christensen**

Inventor's signature *Kelly M. Christensen*

Date 11-8-01

Residence: **935 N. Dos Robles Avenue, Alhambra, CA 91801**

Citizenship: **United States**

Post Office Address: Same as above.

Full name of second inventor: **Barry D. Thomas**

Inventor's signature Barry D. Thomas

Date 11/8/01

Residence: **23774 Burton Street, West Hills, CA 91304**

Citizenship: **United States**

Post Office Address: Same as above.

Full name of third inventor: **Thomas J. Smyth**

Inventor's signature Thomas J. Smyth

Date 11/8/01

Residence: **10723 Valley Spring Lane, North Hollywood, CA 91602**

Citizenship: **United States**

Post Office Address: Same as above.

Send Correspondence To:
KNOBBE, MARTENS, OLSON & BEAR, LLP
Customer No. 20,995

H:\DOCS\LVH\LWH-6437.DOC:jk
110801

ES&S

IN THE UNITED STATES PATENT AND TRADEMARK OFFICE

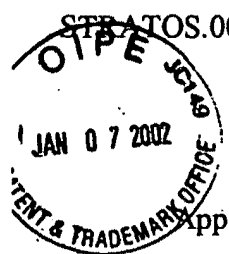

Applicant : Christensen, et al.)
)
 App. No. : 09/953,335)
)
 Filed : September 13, 2001)
)
 For : SYSTEM AND METHOD FOR)
 ORDERING AND DELIVERING)
 MEDIA CONTENT)
)
 Examiner : Unknown)
)

ESTABLISHMENT OF RIGHT OF ASSIGNEE TO TAKE ACTION
AND
REVOCAION AND POWER OF ATTORNEY

Assistant Commissioner for Patents
 Washington, D.C. 20231

Dear Sir:

The undersigned is empowered to act on behalf of the assignee below (the "Assignee"). A true copy of the original Assignment of the above-captioned application from the inventor(s) to the Assignee is attached hereto. This Assignment represents the entire chain of title of this invention from the Inventor(s) to the Assignee.

I declare that all statements made herein are true, and that all statements made upon information and belief are believed to be true, and further, that these statements were made with the knowledge that willful, false statements and the like so made are punishable by fine or imprisonment, or both, under 18 U.S.C. § 1001, and that willful, false statements may jeopardize the validity of the application, or any patent issuing thereon.

The undersigned hereby revokes any previous powers of attorney in the subject application, and hereby appoints the registrants of Knobbe, Martens, Olson & Bear, LLP, 620 Newport Center Drive, Sixteenth Floor, Newport Beach, California 92660, Telephone (949) 760-0404, Customer No. 20,995, as its attorneys with full power of substitution and

App. No. : 08,335
Filed : September 13, 2001

revocation to prosecute this application and to transact all business in the U.S. Patent and Trademark Office connected herewith. This appointment is to be to the exclusion of the inventor(s) and his attorney(s) in accordance with the provisions of 37 C.F.R. § 3.71.

Please use Customer No. 20,995 for all communications.

STRATOSAUDIO, INC.

Dated: November 8, 2001

By: Kelley M. Osterman

Title:

Address: 10 Universal City Plaza, Suite 2000
Universal City, CA 91608

H:\DOCS\LWHLWH-6395.DOC:jk
102601

COPY

Application No.: 09/953,335
Filing Date: September 13, 2001

PATENT
Client Code: STRATOS.001A
Page 1

ASSIGNMENT

WHEREAS, We, Kelly M. Christensen, a United States citizen, residing at 935 N. Dos Robles Avenue, Alhambra, CA 91801; Barry D. Thomas, a United States citizen, residing at 23774 Burton Street, West Hills, CA 91304; and Thomas J. Smyth, a United States citizen, residing at 10723 Valley Spring Lane, North Hollywood, CA 91602, have invented certain new and useful improvements in a SYSTEM AND METHOD FOR ORDERING AND DELIVERING MEDIA CONTENT for which we have filed an application for Letters Patent in the United States, September 13, 2001;

AND WHEREAS, STRATOSAUDIO, INC. (hereinafter "ASSIGNEE"), a Delaware Corporation, with its principal place of business at 10 Universal City Plaza, Suite 2000, Universal City, CA 91608, desires to acquire the entire right, title, and interest in and to the said improvements and the said Application:

NOW, THEREFORE, in consideration of the sum of One Dollar (\$1.00) to me in hand paid, and other good and valuable consideration, the receipt of which is hereby acknowledged, we, the said inventors, do hereby acknowledge that we have sold, assigned, transferred and set over, and by these presents do hereby sell, assign, transfer and set over, unto the said ASSIGNEE, its successors, legal representatives and assigns, the entire right, title, and interest throughout the world in, to and under the said improvements, and the said application and all provisional applications relating thereto, and all divisions, renewals and continuations thereof, and all Letters Patent of the United States which may be granted thereon and all reissues and extensions thereof, and all rights of priority under International Conventions and applications for Letters Patent which may hereafter be filed for said improvements in any country or countries foreign to the United States, and all Letters Patent which may be granted for said improvements in any country or countries foreign to the United States and all extensions, renewals and reissues thereof; and we hereby authorize and request the Commissioner of Patents of the United States, and any Official of any country or countries foreign to the United States, whose duty it is to issue patents on applications as aforesaid, to issue all Letters Patent for said improvements to the said ASSIGNEE, its successors, legal representatives and assigns, in accordance with the terms of this instrument.

AND WE HEREBY covenant and agree that we will communicate to the said ASSIGNEE, its successors, legal representatives and assigns, any facts known to us respecting said improvements, and testify in any legal proceeding, sign all lawful papers, execute all divisional, continuing and reissue applications, make all rightful oaths and generally do everything possible to aid the said ASSIGNEE, its successors, legal representatives and assigns, to obtain and enforce proper patent protection for said improvements in all countries.

IN TESTIMONY WHEREOF, I hereunto set my hand and seal this 8th day of November, 2001

Kelly M. Christensen
Kelly M. Christensen

STATE OF California
COUNTY OF Los Angeles } ss.

On Nov. 8, 2001, before me, Nobuko Christy, a notary public, personally appeared Kelly M. Christensen personally known to me (or proved to me on the basis of satisfactory evidence) to be the person(s) whose name(s) is/are subscribed to the within instrument, and acknowledged to me that he executed the same in his authorized capacity(ies), and that by his signature(s) on the instrument the person(s), or the entity upon behalf of which the person(s) acted, executed the instrument.

WITNESS my hand and official seal

[SEAL]

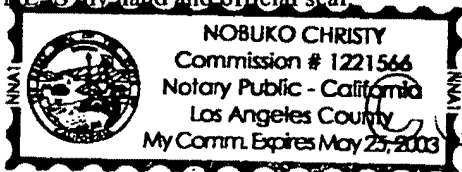

Nobuko Christy

Notary Signature

IN TESTIMONY WHEREOF, I hereunto set my hand and seal this 8 day of November, 2001.

Barry D. Thomas
Barry D. Thomas

STATE OF California }
COUNTY OF Los Angeles } ss.

On Nov. 8, 2001, before me, Nobuko Christy, a notary public, personally appeared Barry D. Thomas personally known to me (or proved to me on the basis of satisfactory evidence) to be the person(s) whose name(s) is/are subscribed to the within instrument, and acknowledged to me that he executed the same in his authorized capacity(ies), and that by his signature(s) on the instrument the person(s), or the entity upon behalf of which the person(s) acted, executed the instrument.

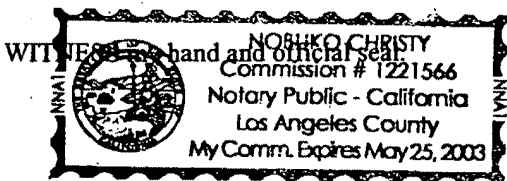

Nobuko Christy
Notary Signature

IN TESTIMONY WHEREOF, I hereunto set my hand and seal this 8th day of NOVEMBER, 2001.

Thomas J. Smyth
Thomas J. Smyth

STATE OF California }
COUNTY OF Los Angeles } ss.

On Nov. 8, 2001, before me, Nobuko Christy, a notary public, personally appeared Thomas J. Smyth personally known to me (or proved to me on the basis of satisfactory evidence) to be the person(s) whose name(s) is/are subscribed to the within instrument, and acknowledged to me that he executed the same in his authorized capacity(ies), and that by his signature(s) on the instrument the person(s), or the entity upon behalf of which the person(s) acted, executed the instrument.

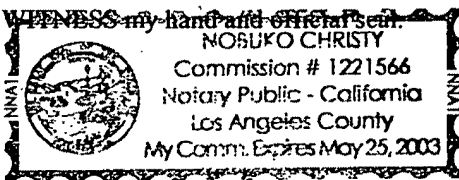

Nobuko Christy
Notary Signature

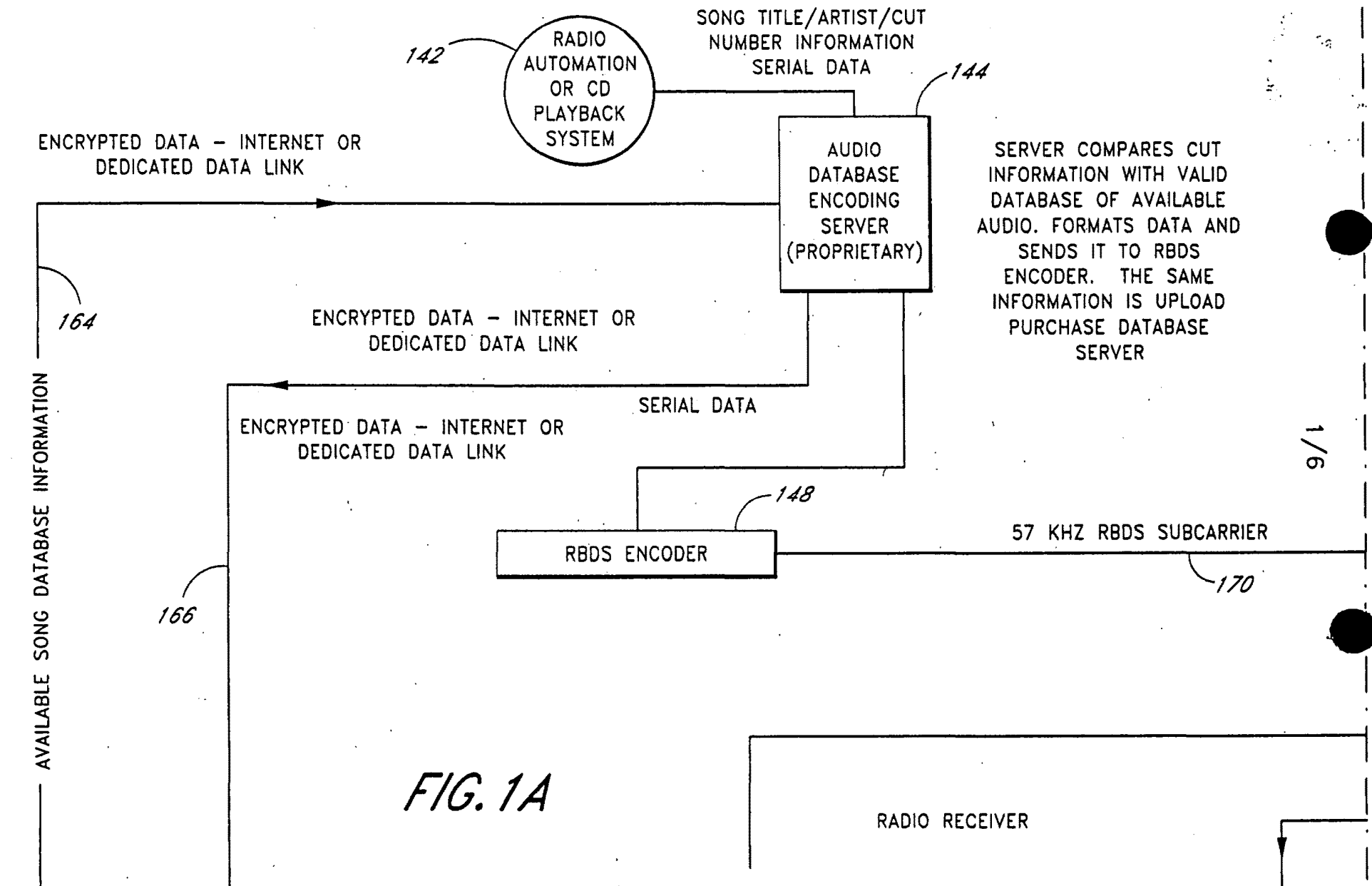

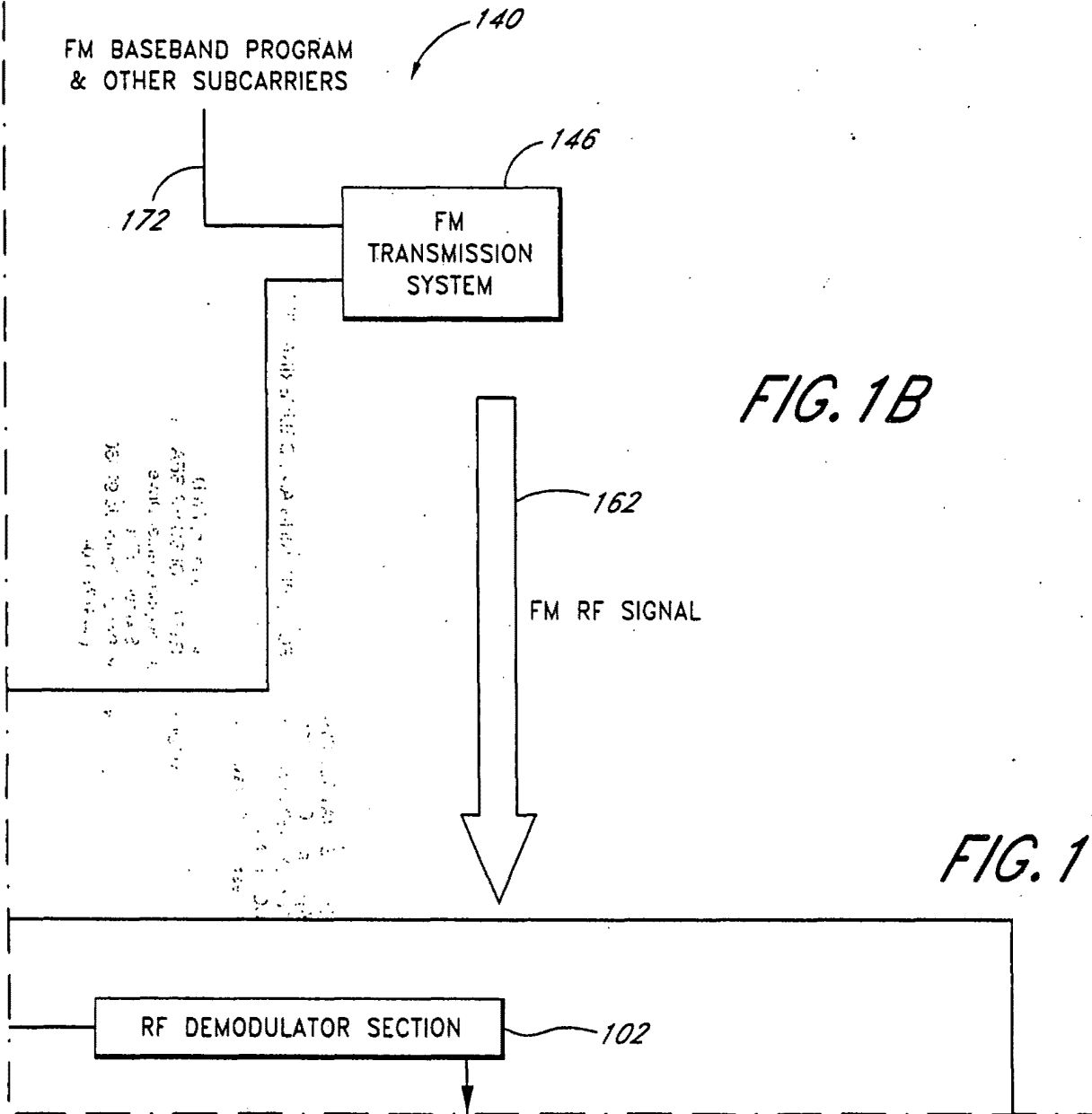

| | |
|---------|---------|
| FIG. 1A | FIG. 1B |
| FIG. 1C | FIG. 1D |

FIG. 1C

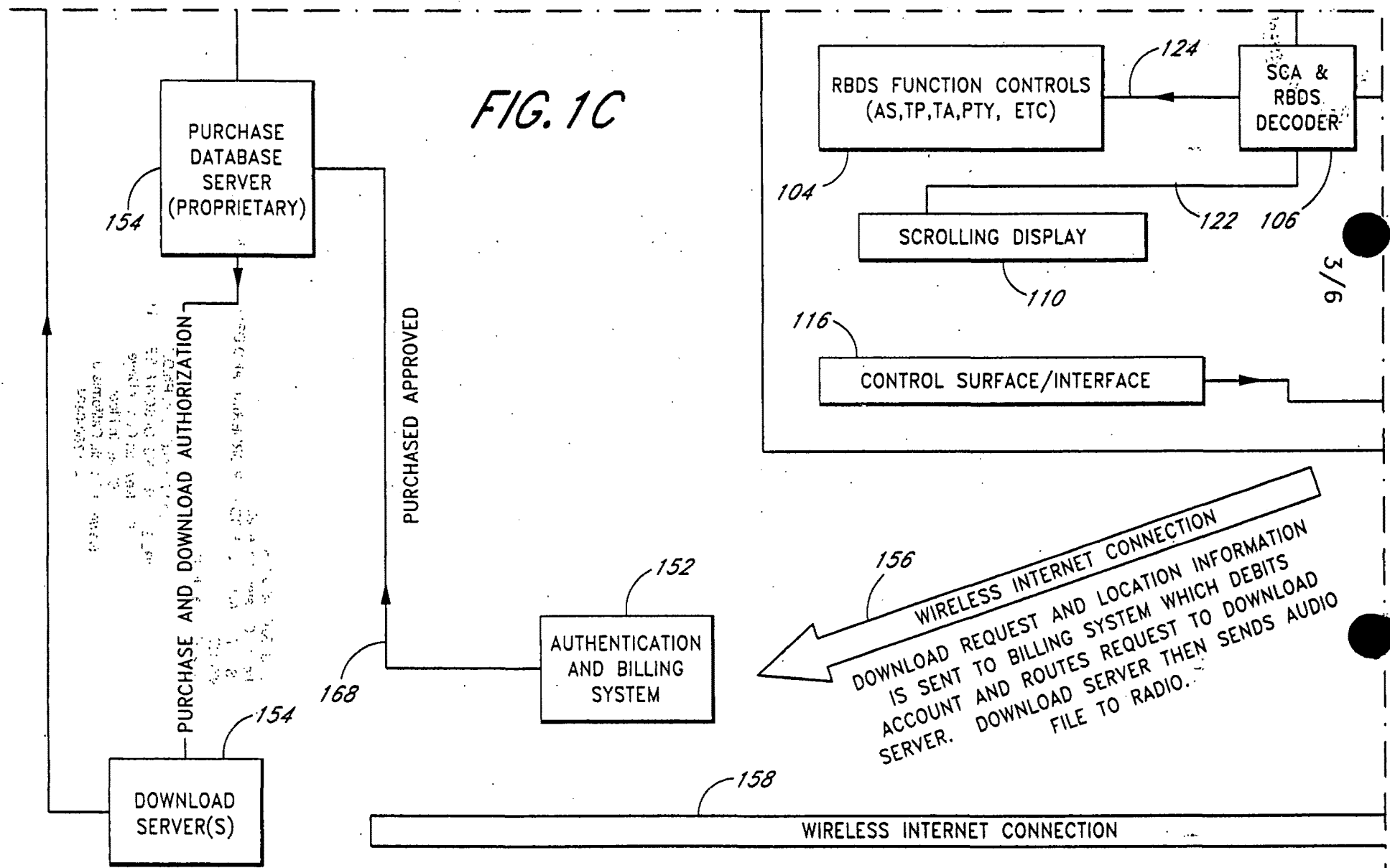

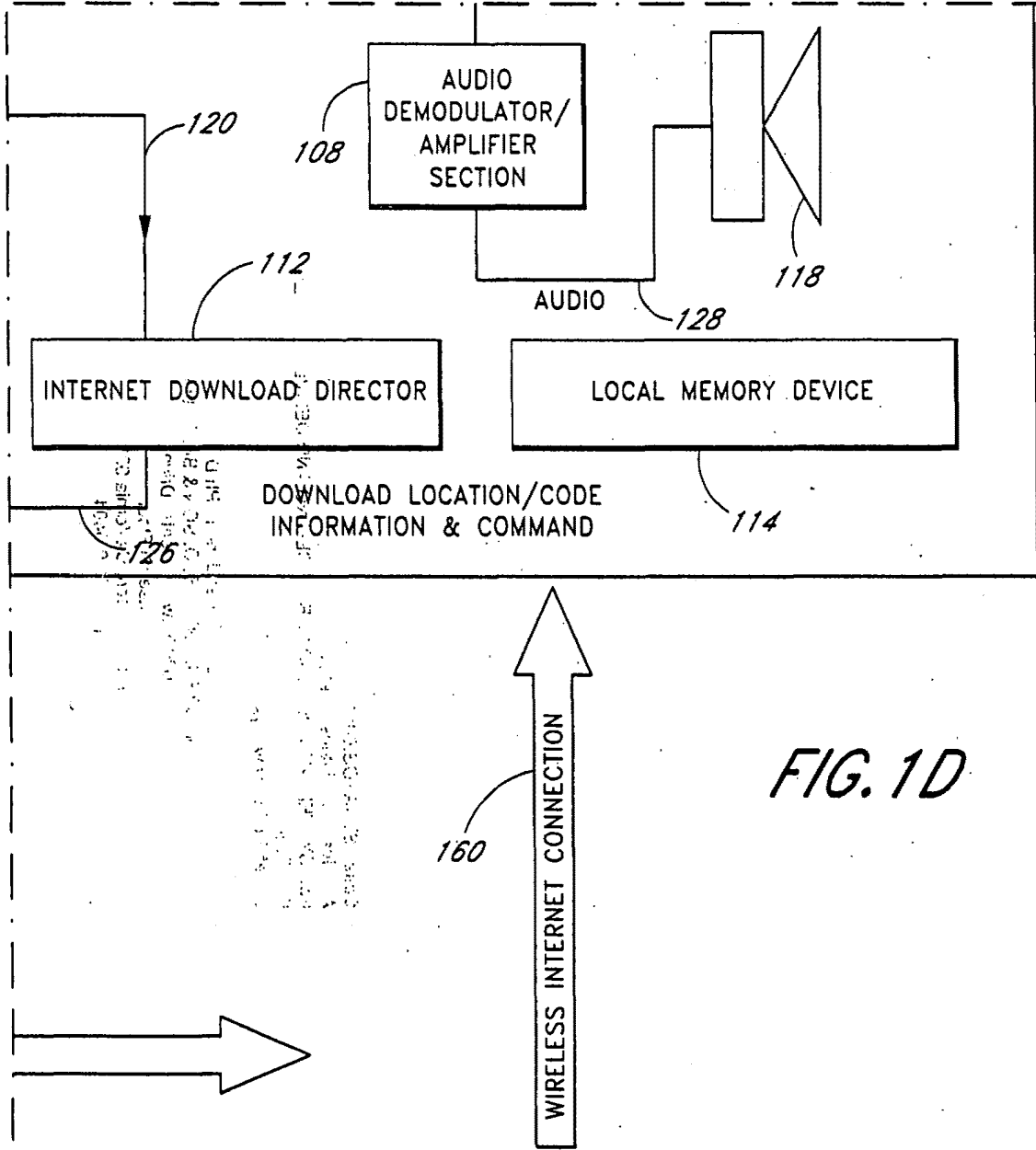
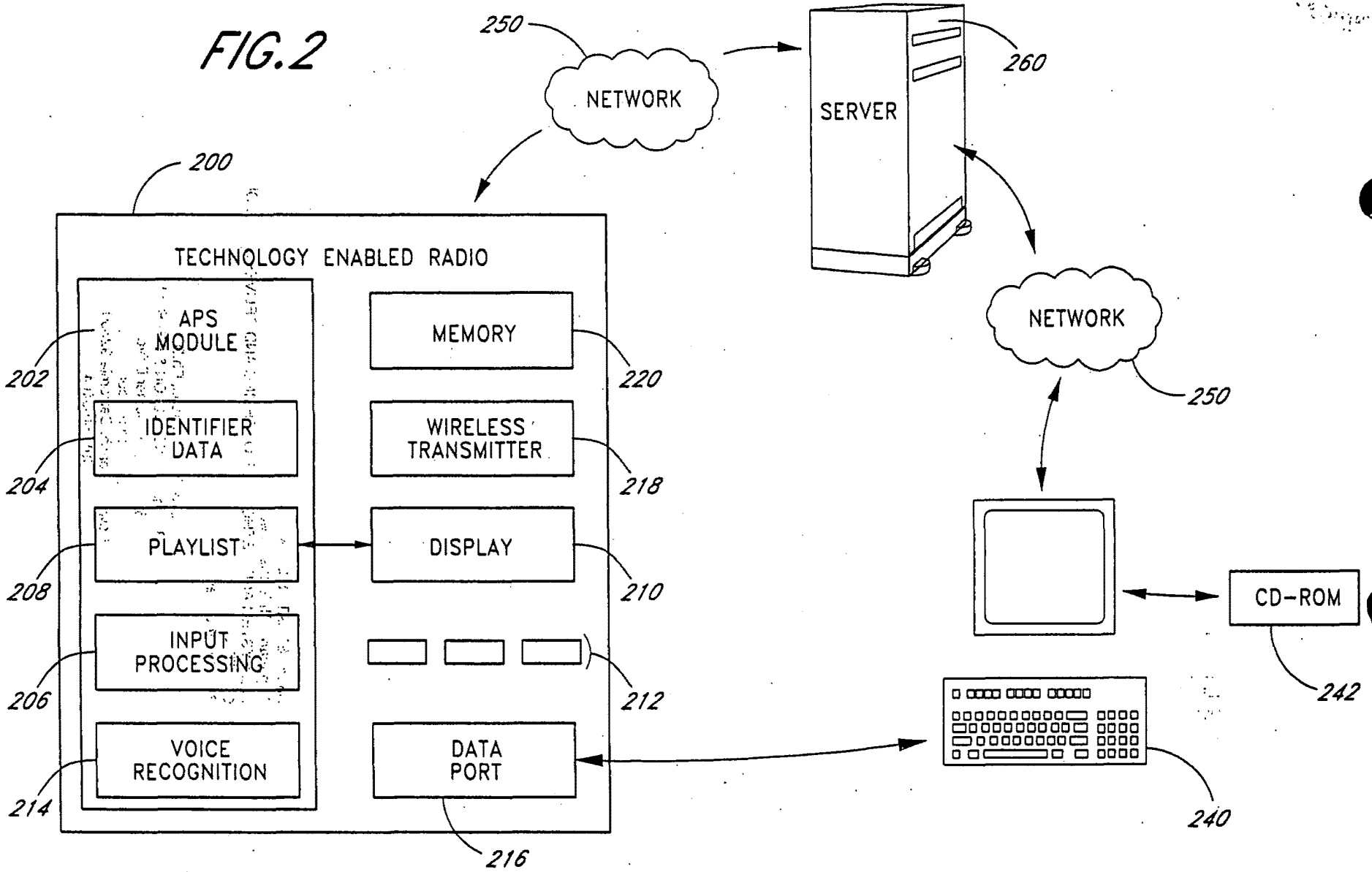

FIG. 1D



FIG. 2



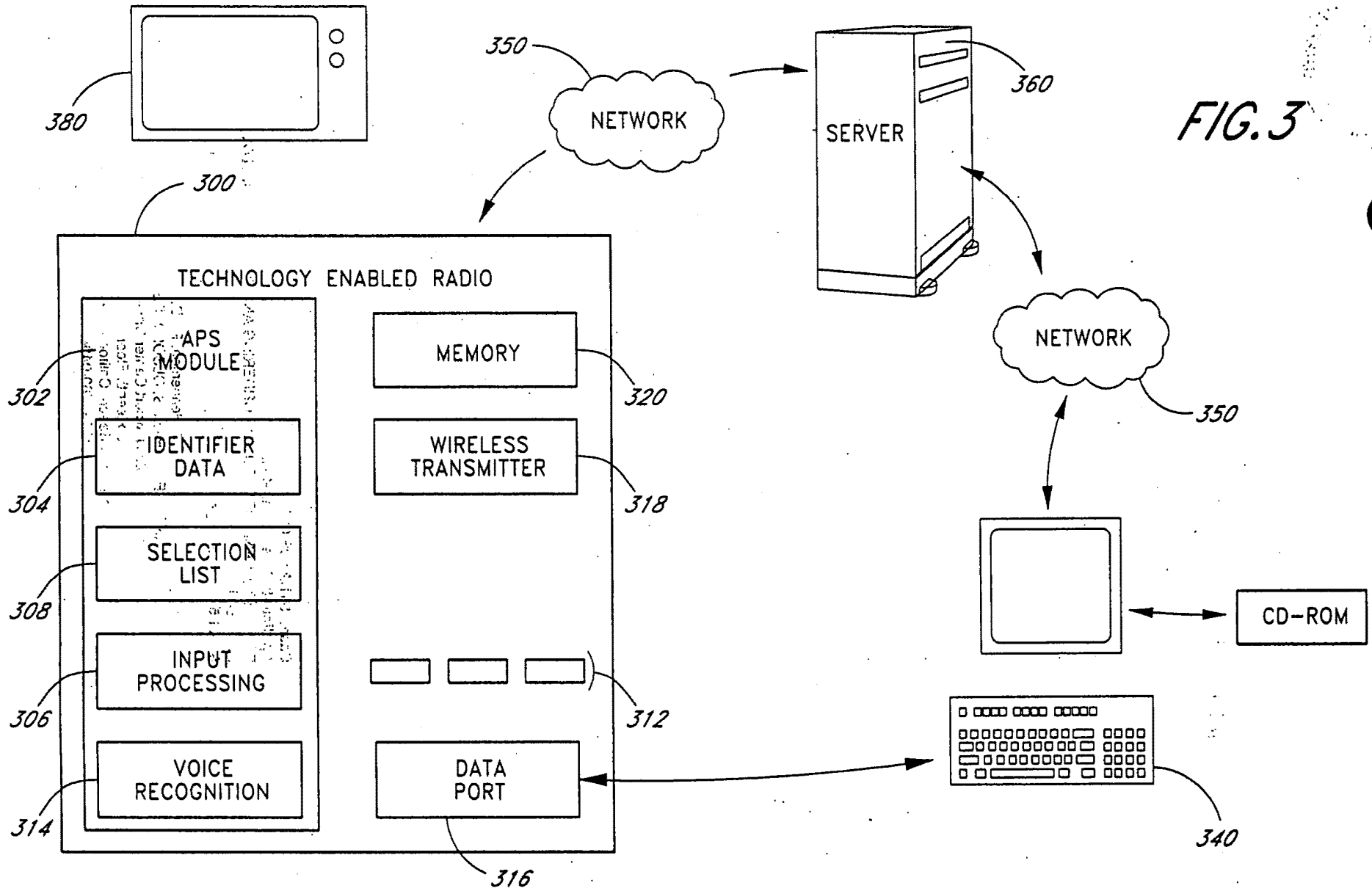
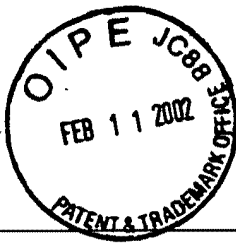

FIG. 3

696



Rec'd 2681
PATENT #4
S.I
04-18-02

Case Docket No. STRATOS.001A
Date: February 7, 2002

IN THE UNITED STATES PATENT AND TRADEMARK OFFICE

Applicant(s) : Christensen, et al.
Appl. No. : 09/953,335
Filed : September 13, 2001
For : SYSTEM AND METHOD
FOR ORDERING AND
DELIVERING MEDIA
CONTENT
Examiner : Unknown
Group Art Unit : 2681

I hereby certify that this correspondence and all marked attachments are being deposited with the United States Postal Service as first class mail in an envelope addressed to: Assistant Commissioner for Patents, Washington, D.C. 20231, on

February 7, 2002
(Date)
Lee W. Henderson
Lee W. Henderson Ph.D., Reg. No. 41,830
RECEIVED
FEB 15 2002
Technology Center 2600

TRANSMITTAL LETTER

United States Patent and Trademark Office
PO Box 2327
Arlington, VA 22202

ATTENTION: APPLICATION BRANCH

Dear Sir:

Enclosed for filing in the above-identified application are:

- (X) An Information Disclosure Statement.
- (X) A PTO Form 1449 with twelve (12) references.
- (X) The Commissioner is hereby authorized to charge any additional fees which may be required, or credit any overpayment, to Account No. 11-1410.
- (X) Return prepaid postcard.

Lee W. Henderson
Lee W. Henderson Ph.D.
Registration No. 41,830
Attorney of Record

STRATOS.001A



PATENT

IN THE UNITED STATES PATENT AND TRADEMARK OFFICE

Applicant : Christensen, et al.) Group Art Unit 2681
)
 App. No. : 09/953,335)
)
 Filed : September 13, 2001)
)
 For : SYSTEM AND METHOD)
 FOR ORDERING AND)
 DELIVERING MEDIA)
 CONTENT)
)
 Examiner : Unknown)
)

RECEIVED
 FEB 15 2002
 Technology Center 2600

INFORMATION DISCLOSURE STATEMENT

United States Patent and Trademark Office
 PO Box 2327
 Arlington, VA 22202

Dear Sir:

Enclosed is form PTO-1449 listing references that are also enclosed. This Information Disclosure Statement is being filed before the receipt of a first Office Action on the merits, and presumably no fee is required in accordance with 37 C.F.R. § 1.97(b)(3). If a first Office Action on the merits was mailed before the mailing date of this Statement, the Commissioner is authorized to charge the fee set forth in 37 C.F.R. § 1.17(p) to Deposit Account No. 11-1410.

Respectfully submitted,
 KNOBBE, MARTENS, OLSON & BEAR, LLP

Dated: Feb 7, 2002

By: Lee W. Henderson
 Lee W. Henderson Ph.D., Reg. No. 41,830
 Attorney of Record
 620 Newport Center Drive, 16th Floor
 Newport Beach, CA 92660
 (949) 760-0404

H:\DOCS\LWHLWH-6864.DOC:jk
020702



PATENT ABSTRACTS OF JAPAN

(11) Publication number: 2000292182 A

(43) Date of publication of application: 20.10.00

(51) Int. Cl

G01C 21/00

G08G 1/09

G08G 1/0969

G09F 21/04

H04B 7/26

H04Q 7/34

H04H 1/00

(21) Application number: 11100172

(71) Applicant: DENTSU INC

(22) Date of filing: 07.04.99

(72) Inventor: IJIMA AKIO

(54) **ADVERTISEMENT SYSTEM FOR MOVABLE BODY AND ADVERTISEMENT INFORMATION-REPORTING METHOD FOR MOVABLE BODY**

target into a smart card, presents the card to a service store and receives service based on the coupon data. Also, a reservation-reporting device 28 makes reservation/reservation purchase or the like to an advertisement target service store.

(57) Abstract:

COPYRIGHT: (C)2000,JPO

PROBLEM TO BE SOLVED: To enable a passenger to view or listen to advertisement information in a safer state and to reserve to purchase an advertisement target by storing a received advertisement data signal and at the same time verifying advertisement information that matches the position of a movable body for reporting to the passenger.

SOLUTION: An advertisement information data is transmitted from a broadcasting electronic wave to a movable body 11, and a data is stored at a storage that is mounted to the monitor of the receiver of an advertisement information-reporting part 15 that is installed at the movable body 11. When the movable body 11 enters an advertisement target area by verifying the position of the movable body 11 using a GPS, the advertisement information-reporting part 15 reports the advertise information to a passenger by voices and images. A coupon data-writing device 27 downloads the coupon data of the advertisement

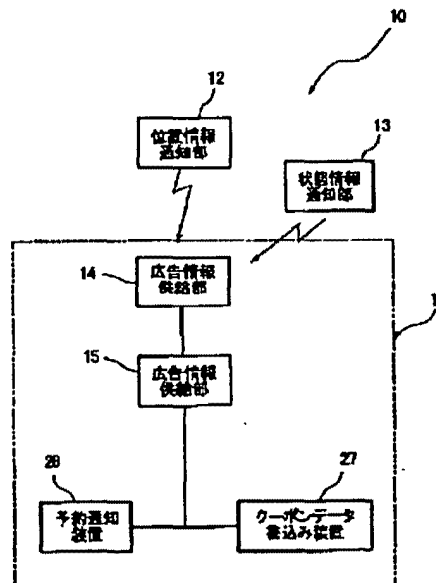

#5
Power
R.C.
10/17/02

STRATOS.001A

PATENT

IN THE UNITED STATES PATENT AND TRADEMARK OFFICE

| | | | | |
|-----------|---|---|---|---|
| Applicant | : | Christensen et al |) | Group Art Unit: Unknown |
| Appl. No. | : | 09/953,335 |) | I hereby certify that this correspondence is being sent via facsimile addressed to: Cantwell and Paxton, on |
| Filed | : | September 13, 2001 |) | <u>October 10, 2002</u> |
| | | |) | (Date) |
| For | : | SYSTEM AND METHOD FOR ORDERING AND DELIVERING MEDIA CONTENT |) | <u>Perry D. Oldham, Reg. No. 52,082</u> |
| Examiner | : | None Assigned |) | |

POWER TO INSPECT AND MAKE COPIES UNDER
37 C.F.R. § 1.14 AND M.P.E.P. § 104

United States Patent and Trademark Office
P.O. Box 2327
Arlington, VA 22202

Dear Sir:

Pursuant to 37 C.F.R. § 1.14 and M.P.E.P. § 104, please permit Patsy Paxton or her representative, to inspect the above-entitled application, and to make copies of any of the papers they may desire.

Respectfully submitted,
KNOBBE, MARTENS, OLSON & BEAR, LLP

Dated: 10/10/2002

By: Perry Oldham
Perry D. Oldham
Registration No. 52,082
Attorney of Record
2040 Main Street
Fourteenth Floor
Irvine, CA 92614
(949) 760-0404

H:\DOCS\PDOW\DO-1827.DOC
101002

#6
3627^{BT}
02-3-03



STRATOS.001A

PATENT

IN THE UNITED STATES PATENT AND TRADEMARK OFFICE

Applicant : Christensen et al)
App. No. : 09/953,335)
Filed : September 13, 2001)
For : SYSTEM AND METHOD)
FOR ORDERING AND)
DELIVERING MEDIA)
CONTENT)
Examiner : None Assigned)

Group Art Unit Unknown

I hereby certify that this correspondence and all marked attachments are being deposited with the United States Postal Service as first-class mail in an envelope addressed to: United States Patent and Trademark Office, PO Box 2327, Arlington VA 22202, on

January 17th 2003
(Date)
Perry Oldham
Perry D. Oldham, Reg. No. 52,082

RECEIVED

INFORMATION DISCLOSURE STATEMENT JAN 27 2003

GROUP 3600

United States Patent and Trademark Office
P.O. Box 2327
Arlington, VA 22202

Dear Sir:

Enclosed is form PTO-1449 listing three references that are also enclosed. This Information Disclosure Statement is being filed before the mailing date of a final action under 37 C.F.R. § 1.113 and before the mailing date of a Notice of Allowance under § 1.311. A certification under 37 C.F.R. § 1.97(e) is set forth below. Thus, no fee is required as set forth below in 37 C.F.R. § 1.97(c).

CERTIFICATION UNDER 37 C.F.R. § 1.97(e)(1)

I hereby certify that each item of information contained in this Statement was first cited in a communication from a foreign Patent Office in a counterpart foreign application not more than 30 days prior to the filing of this Information Disclosure Statement.

Respectfully submitted,
KNOBBE, MARTENS, OLSON & BEAR, LLP

Dated: 01/17/2003

By: Perry Oldham
Perry D. Oldham
Registration No. 52,082
Attorney of Record
Customer No. 20,995
(949) 760-0404

PCT

WELTORGANISATION FÜR GEISTIGES EIGENTUM
Internationales Büro



INTERNATIONALE ANMELDUNG VERÖFFENTLICHT NACH DEM VERTRAG ÜBER DIE
INTERNATIONALE ZUSAMMENARBEIT AUF DEM GEBIET DES PATENTWESENS (PCT)

| | | |
|---|--|---|
| <p>(51) Internationale Patentklassifikation ⁶ : H04H 9/00</p> | <p>A1</p> | <p>(11) Internationale Veröffentlichungsnummer: WO 99/35771</p> <p>(43) Internationales Veröffentlichungsdatum: 15. Juli 1999 (15.07.99)</p> |
| <p>(21) Internationales Aktenzeichen: PCT/CH99/00006</p> <p>(22) Internationales Anmeldedatum: 6. Januar 1999 (06.01.99)</p> <p>(30) Prioritätsdaten: 24/98 9. Januar 1998 (09.01.98) CH</p> <p>(71) Anmelder (für alle Bestimmungsstaaten ausser US): SWISS-COM AG [CH/CH]; Viktoriastrasse 21, CH-3050 Bern (CH).</p> <p>(72) Erfinder; und (75) Erfinder/Anmelder (nur für US): RITTER, Rudolf [CH/CH]; Rossweidweg 8, CH-3052 Zollikofen (CH).</p> <p>(74) Anwalt: BOVARD AG; Optingenstrasse 16, CH-3000 Bern 25 (CH).</p> | <p>(81) Bestimmungsstaaten: AL, AM, AT, AT (Gebrauchsmuster), AU, AZ, BA, BB, BG, BR, BY, CA, CH, CN, CU, CZ, CZ (Gebrauchsmuster), DE, DE (Gebrauchsmuster), DK, DK (Gebrauchsmuster), EE, EE (Gebrauchsmuster), ES, FI, FI (Gebrauchsmuster), GB, GD, GE, GH, GM, HR, HU, ID, IL, IN, IS, JP, KE, KG, KP, KR, KZ, LC, LK, LR, LS, LT, LU, LV, MD, MG, MK, MN, MW, MX, NO, NZ, PL, PT, RO, RU, SD, SE, SG, SI, SK, SK (Gebrauchsmuster), SL, TJ, TM, TR, TT, UA, UG, US, UZ, VN, YU, ZW, ARIPO Patent (GH, GM, KE, LS, MW, SD, SZ, UG, ZW), eurasisches Patent (AM, AZ, BY, KG, KZ, MD, RU, TJ, TM), europäisches Patent (AT, BE, CH, CY, DE, DK, ES, FI, FR, GB, GR, IE, IT, LU, MC, NL, PT, SE), OAPI Patent (BF, BJ, CF, CG, CI, CM, GA, GN, GW, ML, MR, NE, SN, TD, TG).</p> <p>Veröffentlicht <i>Mit internationalem Recherchenbericht.</i></p> | |

(54) Title: METHOD FOR INTERACTIVE TELECOMMUNICATION

(54) Bezeichnung: VERFAHREN ZUR INTERAKTIVEN TELEKOMMUNIKATION

(57) Abstract

The invention relates to a telecommunication method comprising the following steps: integration of programme-related digital data into a TV or radio programme and transmission of said programme; reception and playback of the programme by a mobile telephone combined with a TV or radio receiving system, where the receiving system comprises a chip card reader into which the user of the receiving system can insert a SIM card to identify himself; display of at least one option corresponding to the integrated digital data on a display of the receiving system and selection of an option by the user of the receiving system; preparation of a message corresponding to the selected option by the SIM card, where the message prepared comprises at least one data field from the digital data being received; transmission of the above message by a bidirectional mobile telephone network to a server; automatic user identification by a server, whereby the user identification process uses information stored in the identification card and transmitted by the above bidirectional telecommunications network; linking of at least some received data with user-specific data.

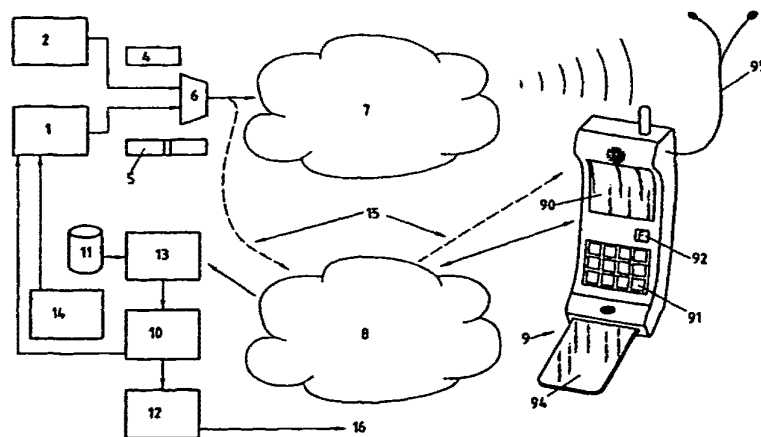

(57) Zusammenfassung

Telekommunikationsverfahren, das folgende Schritte umfasst: Integrierung von programmbegleitenden digitalen Daten in einem TV- oder Radioprogramm, und Aussendung von diesem Programm, Empfang und Wiedergabe von diesem Programm durch ein Mobilfunkgerät, das mit einem TV- bzw. Radioempfangssystem kombiniert ist, wobei das Empfangssystem einen Chipkartenleser umfasst, in dem der Benutzer des Empfangssystems eine SIM-Karte einschieben kann, um sich zu identifizieren, Anzeige von mindestens einer den integrierten digitalen Daten entsprechenden Option auf einer Anzeige des Empfangssystems, und Auswahl einer Option durch den Benutzer des Empfangssystems, Vorbereitung einer der ausgewählten Option entsprechenden Meldung durch die SIM-Karte, wobei die vorbereitete Meldung mindestens ein Datenfeld aus den empfangenen digitalen Daten umfasst, Übermittlung der genannten Meldung durch ein bidirektionales Mobilfunknetz an einen Server, automatische Benutzererkennung durch den Server, wobei die Benutzererkennung eine in der Identifizierungskarte gespeicherte und durch das genannte bidirektionale Telekommunikationsnetz übermittelte Information benutzt, Verknüpfung von mindestens einigen empfangenen Daten mit benutzerspezifischen Daten.

LEDIGLICH ZUR INFORMATION

Codes zur Identifizierung von PCT-Vertragsstaaten auf den Kopfbögen der Schriften, die internationale Anmeldungen gemäss dem PCT veröffentlichen.

| | | | | | | | |
|----|------------------------------|----|--------------------------------------|----|--|----|-----------------------------------|
| AL | Albanien | ES | Spanien | LS | Lesotho | SI | Slowenien |
| AM | Armenien | FI | Finnland | LT | Litauen | SK | Slowakei |
| AT | Österreich | FR | Frankreich | LU | Luxemburg | SN | Senegal |
| AU | Australien | GA | Gabun | LV | Lettland | SZ | Swasiland |
| AZ | Aserbaidshan | GB | Vereinigtes Königreich | MC | Monaco | TD | Tschad |
| BA | Bosnien-Herzegowina | GE | Georgien | MD | Republik Moldau | TG | Togo |
| BB | Barbados | GH | Ghana | MG | Madagaskar | TJ | Tadschikistan |
| BE | Belgien | GN | Guinea | MK | Die ehemalige jugoslawische Republik Mazedonien | TM | Turkmenistan |
| BF | Burkina Faso | GR | Griechenland | ML | Mali | TR | Türkei |
| BG | Bulgarien | HU | Ungarn | MN | Mongolei | TT | Trinidad und Tobago |
| BJ | Benin | IE | Irland | MR | Mauretanien | UA | Ukraine |
| BR | Brasilien | IL | Israel | MW | Malawi | UG | Uganda |
| BY | Belarus | IS | Island | MX | Mexiko | US | Vereinigte Staaten von Amerika |
| CA | Kanada | IT | Italien | NE | Niger | UZ | Usbekistan |
| CF | Zentralafrikanische Republik | JP | Japan | NL | Niederlande | VN | Vietnam |
| CG | Kongo | KE | Kenia | NO | Norwegen | YU | Jugoslawien |
| CH | Schweiz | KG | Kirgisistan | NZ | Neuseeland | ZW | Zimbabwe |
| CI | Côte d'Ivoire | KP | Demokratische Volksrepublik Korea | PL | Polen | | |
| CM | Kamerun | KR | Republik Korea | PT | Portugal | | |
| CN | China | KZ | Kasachstan | RO | Rumänien | | |
| CU | Kuba | LC | St. Lucia | RU | Russische Föderation | | |
| CZ | Tschechische Republik | LI | Liechtenstein | SD | Sudan | | |
| DE | Deutschland | LK | Sri Lanka | SE | Schweden | | |
| DK | Dänemark | LR | Liberia | SG | Singapur | | |
| EE | Estland | | | | | | |

VERFAHREN ZUR INTERAKTIVEN TELEKOMMUNIKATION

Die vorliegende Erfindung betrifft ein Telekommunikationsverfahren und ein Empfangssystem zur Durchführung dieses Verfahrens. Die Erfindung betrifft insbesondere ein Telekommunikationsverfahren, das in einem
5 Broadcastkanal eingesetzt werden kann.

Die verbreitetsten Broadcastsysteme sind rein monodirektional und weisen daher keinen Rückkanal auf, mit dem der Empfänger Antwortmeldungen an den Aussender senden könnte. Das ist zum Beispiel der Fall in den meisten Radio- und TV-Broadcastsystemen. Wenn der Empfänger,
10 zum Beispiel der Radiozuhörer oder der Fernsehzuschauer, auf eine Sendung oder auf eine Werbung reagieren möchte, muss er daher auf ein anderes Telekommunikationssystem zugreifen, zum Beispiel auf sein Telefon. Wenn zum Beispiel für ein Produkt am Fernsehen geworben wird, muss sich der interessierte Kunde sofort die Adresse oder die Telefonnummer des
15 Produktlieferanten notieren und ihn später manuell anrufen. Der Kunde muss sich dann beim Produktlieferanten selber identifizieren und das Produkt, das ihn interessiert, telefonisch angeben. Dieses Verfahren ist äusserst umständlich und fehleranfällig. Aus diesem Grund sind die meisten Broadcastsysteme nur bedingt geeignet, um den Empfänger zu
20 Spontaneinkäufen während oder gleich nach einer Werbung zu bewegen. Ausserdem ist es schwierig, TV- oder Radioprogramme zu gestalten, in denen ein sofortiges Feedback der Empfänger benötigt wird.

Es ist ausserdem schon bekannt, programmbegleitende digitale Daten einem Radio- oder Fernsehprogramm hinzuzufügen. Bei den
25 Fernsehsystemen können somit digitale Daten während des vertikalen Rasterintervalls übertragen werden. Eine entsprechende Hardware- und Softwarevorrichtung im Fernseher oder im PC des Empfängers ermöglicht es, diese digitalen Daten zu decodieren, sie auszuwählen und zu speichern oder auf dem Bildschirm des Empfängers anzuzeigen. In den Radiosystemen wird
30 die Übertragung von programmbegleitenden Daten zusätzlich zu den Radioprogrammen vor allem mit den digitalen Radiosystemen DAB (Digital Audio Broadcasting) verwendet. Die DAB- Technologie ermöglicht es auf diese

Weise, sowohl Radioprogramme als auch programmbegleitende Dienste (Program Associated Data, PAD) zu übertragen. DAB-Empfänger, die einen Datendecoder und eine entsprechende Anzeige enthalten, werden schon angeboten. Dieser Kanal für programmbegleitende Daten ist leider, wie der
5 Radio- oder TV-Programmkanal, nur monodirektional.

Broadcastkanäle, die über einen Rückkanal verfügen, bei denen digitale Daten zwischen einem Server und mehreren Empfängern zum Beispiel durch einen Push-Kanal im Internet gesandt werden, sind inzwischen auch bekannt. Je nach Wahl und Interesse des Benutzers können diese digitalen
10 Daten dann im Empfangssystem des Benutzers gespeichert und/oder gefiltert werden. Beispielsweise kann ein komplettes Informationsprogramm an den Benutzer übertragen werden, der dann z.B. entscheidet, nur die Informationen betreffend Sportartikel oder Politik anzuzeigen oder zu speichern. Mit diesen Systemen können die Empfänger passiv ein Programm empfangen und nur
15 dann antworten, wenn sie zum Beispiel mehr Information über ein Thema oder wenn sie ein Produkt bestellen wollen. Es ist aber bekanntlich schwierig, Benutzer zuverlässig im Internet zu identifizieren, so dass dieses Verfahren nur bedingt geeignet ist, um vertrauliche oder sicherheitskritische Daten, wie zum Beispiel Produktbestellungen oder Zahlungsaufträge, an den Sender oder an
20 einen Lieferanten zu übermitteln. Es ist ferner ein Mindestmass an Informatik-Kenntnissen seitens des Benutzers erforderlich, um von einem durch einen Push-Kanal übertragenes Angebot im Mediaprogramm zu profitieren. Der Benutzer muss beispielsweise eine e-mail-Meldung vorbereiten, die seine eigene Identifizierung, eine Beschreibung des zu bestellenden Produktes
25 sowie die Identifizierung des gewählten Lieferanten enthält. Dieses Verfahren ist daher ziemlich langwierig und mühsam. Ausserdem können eventuelle, durch den Benutzer eingebrachte oder durch Probleme mit der Übermittlung im Telekommunikationsnetz auftretende Fehler nicht leicht ausfindig gemacht werden. Daraus resultiert eine gewichtige Prozentzahl von Aufträgen, die nicht
30 ausgeführt werden können, da z.B. die Angaben vom Benutzer unvollständig oder fehlerhaft eingegeben worden sind.

Es ist daher ein Ziel der vorliegenden Erfindung, ein Telekommunikationssystem anzubieten, das diese Nachteile vermeidet.

Erfindungsgemäss wird dieses Ziel mit Hilfe eines Verfahrens und eines Systems erreicht, die die Merkmale der entsprechenden unabhängigen Ansprüche aufweisen, wobei bevorzugte Ausführungsformen ferner in den Nebenansprüchen angeführt sind.

5 Mit dem erfindungsgemässen System und Verfahren kann der Empfänger Meldungen nicht nur an den Aussender, sondern auch an andere Partner, zum Beispiel an Lieferanten von angepriesenen Produkten, automatisch verfassen und übermitteln.

Die Erfindung wird mit Hilfe der als Beispiel angeführten und in den
10 Figuren dargestellten Beschreibung besser verständlich, wobei:

die Figur 1 eine schematische Ansicht des erfindungsgemässen Systems darstellt;

die Figur 2 eine schematische Ansicht der Struktur der übertragenen Auftragskodes zeigt;

15 die Figur 3 eine Bildschirmansicht zeigt, die vom erfindungsgemässen JAVA-Applet auf der Anzeige des Empfangssystems des Benutzers erzeugt wird, und

die Figur 4 ein Flussdiagramm, mit den verschiedenen Schritten gezeigt werden, die beim Empfang eines entsprechenden Applets im
20 Empfangssystem ausgeführt werden.

Die Figur 1 zeigt schematisch die Systemkomponenten, die für die Ausführung des erfindungsgemässen Verfahrens eingesetzt werden können. Wir werden jetzt die einzelnen Elemente näher beschreiben :

Mit 1 ist ein Marketing-Online-Studio dargestellt. Hier werden
25 individuelle Auftragsnummern 50 vorbereitet, mit JAVA-Applets 50 (JAVA: geschützte Marken von SUN) verpackt und einem oder mehreren Sendeblocks

zugeteilt. Diese Meldungen werden später im Bezug auf Figur 2 näher erläutert.

Im Sendestudio 2 werden die Mediaprogramme vorbereitet und in Sendeblocks aufgeteilt. Ein Sendeblock kann beispielsweise einer Werbung, einem Musikstück, einem Hörspiel, einem Werbespot, einem Film, einer
5 Webseite, usw. entsprechen. Als Sendestudio kommen beispielsweise ein Radiostudio, ein TV-Studio oder ein Internetanbieter in Frage.

Die ausgesandten Sendeblocks 4 werden in 6 mit den zugeteilten Meldungen 5 verknüpft und durch den Broadcastkanal 7 ausgesandt. Der
10 Broadcastkanal 7 kann je nach Anwendung beispielsweise ein FM-Broadcastnetz, ein TV-Broadcastnetz oder ein Pushkanal im Internet sein. Alternativ können die Sendeblocks 4, zum Beispiel Werbemeldungen, und die entsprechenden Meldungen 5 auch durch ein konventionelles Mobilkommunikationsnetz 8 ausgesandt werden, wie mit dem Pfeil 15
15 angedeutet.

Das ausgesandte Mediaprogramm wird durch ein Empfangssystem 9 gemäss der Erfindung empfangen. Das Empfangssystem 9 kann zum Beispiel ein Telekommunikationsmobilgerät mit einem integrierten Radioempfänger
20 sein. Der Benutzer kann mit diesem System ganz konventionell durch ein Mobilfunknetz 8, zum Beispiel ein GSM-Netz, telefonieren, oder es auch als klassischen FM-Empfänger benutzen, um beispielsweise Radioprogramme mit den Kopfhörern 95 zu hören. In einer Variante weist das Empfangssystem statt oder zusätzlich zum Radioempfänger einen Fernsehempfänger auf, um Fernsehprogramme auf der Anzeige 90 des Mobilgeräts anzuschauen.
25 Mobilfunkgeräte, die mit einem ausreichenden Bildschirm versehen sind, zum Beispiel für Videotelefon-Anwendungen, sind bekannt und werden schon kommerziell angeboten ; der Fachmann kann problemlos einen TV-Tuner in ein solches Mobil-Visiophongerät integrieren, damit mit diesem System auch ferngesehen werden kann. Die Mobilfunkfunktionen und die Radio- oder TV-
30 Funktionen lassen sich einzeln oder kombiniert betreiben. Beim Einzelbetrieb kann der Radio- oder TV-Empfänger wie ein klassisches Einzelgerät betrieben werden. Im Kombibetrieb ist der Radio-FM oder der TV-Empfänger operativ

und die Mobilfunkkomponente im Stand-by oder im Kommunikations-Modus. Durch eine spezielle Taste 92 kann der Benutzer beim Empfangen einer interessanten Meldung die Ausführung des Applets 5 und die auf Figur 3 gezeigte Bildschirmdarstellung aktivieren.

5 Das Empfangssystem 9 kann auch aus einem Radio und/oder TV-Empfänger mit im Gehäuse integrierten zusätzlichen Mobilfunkkommunikationskomponenten bestehen. Ebenso ist es möglich, die Mobilfunkkomponenten in einer Fernbedienung für einen Fernseher oder für einen anderen Broadcastempfänger zu integrieren. Ferner kann das
10 Empfangssystem auch aus einem Rechner, zum Beispiel einem PC oder einem Palmtop, mit integriertem Radio, TV und/oder Internetempfängermittel sowie mit Kommunikationsmitteln für ein Mobilfunknetz 8 bestehen. Wie später erklärt, kann aber das erfindungsgemässe Verfahren auch mit einem
15 konventionellen Mobilfunkgerät 9 durchgeführt werden, z.B. mit einem GSM-Endgerät.

Das Empfangssystem 9 enthält ausserdem vorzugsweise bekannte Mittel, um SMS- (Short Message System) und/oder USSD- (Unstructured Supplementary Service Data) Kurzmeldungen zu senden und zu empfangen, sowie bekannte Filtermittel, um spezielle Kurzmeldungen zu erkennen und
20 zwischenspeichern, vorzugsweise gemäss dem SICAP-Verfahren, das unter anderem im Patent EP 0689 368 B1 beschrieben ist. Verschlüsselung und Signierungsmittel sind ausserdem vorzugsweise vorhanden, um empfangene Kurzmeldungen zu entschlüsseln und um auszusendende Kurzmeldungen zu verschlüsseln und zu signieren. Als Verschlüsselungsverfahren kann
25 beispielsweise das TTP-Verfahren eingesetzt werden, oder auch Entschlüsselungsmittel, die nach einem Point-to-Point-Verfahren arbeiten.

Das Empfangssystem 9 kann eine Kurzmeldung mit einer Auftragsnummer an einen Server 13 durch das Mobilfunknetz 8 übermitteln. Der Server 13 verknüpft die empfangene Auftragsnummer mit
30 Benutzeridentifikationsdaten aus einer Teilnehmerdatenbank 11. Diese Benutzeridentifikationsdaten enthalten mindestens die vollständige Adresse des Abonnenten. Vorzugsweise enthalten die Benutzeridentifikationsdaten

ebenfalls die Sprache des Benutzers, seine Bankverbindung bzw. sein Kreditkartenunternehmen, abonnierte Dienste, usw. Die Teilnehmerdatenbank 11 ist vorzugsweise die Datenbank des Betreibers des Telekommunikationsnetzes 8 zur Verwaltung der Abonnenten. Ihr Inhalt ist im Prinzip also äusserst zuverlässig. Sie kann auch eine temporäre Adresse des Teilnehmers enthalten. In einer Variante enthält die Teilnehmerdatenbank die Benutzeridentifikationsdaten nur von den Benutzern, die das System der Erfindung abonniert haben.

Das Empfangssystem 9 enthält Benutzeridentifizierungsmittel, vorzugsweise Chipkartenlesemittel, um den Benutzer des Empfangssystems mit einer Identifizierungskarte zu identifizieren. Solche Chipkartenlesemittel sind unter anderem in GSM-Mobilgeräten üblich, die mit SIM-Karten (Subscriber Identification Module) versehen sind. Andere Identifizierungskarten, zum Beispiel Karten, die unter dem Begriff OpenCard bekannt sind, können aber auch je nach Empfangssystem angewendet werden.

Der Server 13 verknüpft dann mindestens einige der in der vom Benutzer eingegebenen Kurzmeldung enthaltenen Informationen mit den Benutzeridentifikationen, um die nicht vollständig übermittelte Identifizierung des Benutzers zu vervollständigen.

Der Server 13 ist mit einer Produkte-/Information-Lieferanten-Datenbank 10 verbunden. Über diese Datenbank werden die Funktionen des Systems gesteuert. Vorzugsweise enthält sie neu ein Benutzerprofil. Die im Server 13 verknüpften Daten werden mittels dieser Datenbank dem Logistikzentrum 12 des entsprechenden Lieferanten zugestellt, der die bestellten Produkte oder Informationen dann an den Benutzer 16 liefert.

Ein Data-Warehouse-Server 14 analysiert die vom Benutzer 9 empfangene Meldungen und erstellt daher Benutzerprofile, die ein Marketing auf der Ebene Point-to-Point erlauben. Die Benutzer können sich dann ein Benutzerprofil oder eine Gruppe von angebotenen Profilen auf ihre Identifizierungskarte 94 laden, damit sie beim Broadcastverfahren auch direkt angesprochen werden können.

Der Benutzer kann sich ein Profil auch selber bestellen und zuteilen lassen, zum Beispiel mit einer speziellen Auftragsmeldung oder online mit einem Rechner.

Der Prozess, der in den Elementen 9 bis 14 erfolgt, ist in der
5 Patentanmeldung PCT/CH96/00464, deren Inhalt hier übernommen wird, ausführlicher beschrieben.

Die Figur 2 zeigt die Struktur der Meldung 5. Die Auftragsnummer 52 selbst ist zusammen mit dem entsprechenden JAVA-Code 50 verpackt. Dieses Java-Applet wird von der Java-tauglichen SIM-Karte 94 im Mobilgerät 9
10 empfangen, die folglich einen interaktiven Prozess mit dem Benutzer ausführt. Der Java-Code 50 wird nur zwischen dem Aussender 1 und dem Mobilgerät übermittelt, damit dieser interaktive Prozess zwischen der Java-tauglichen SIM-Karte 9 und dem Benutzer erfolgt, jedoch nicht zwischen dem Mobilgerät 9 und dem Server 13. Statt Java können die Applets natürlich auch in einer anderen
15 objekt-orientierten Computersprache geschrieben werden.

Die Meldung 5 umfasst ausserdem ein im Studio 1 erfasstes Benutzerprofil 510, mit dem die für den Benutzer interessanten Daten in der SIM-Karte 94 filtriert werden. Wenn die Erfindung zum Beispiel für den Wertpapierhandel eingesetzt wird, kann zum Beispiel das Benutzerprofil einem
20 Segment von Wertpapieren in einem automatischen Handelssystem entsprechen. Die Datenverarbeitungsmittel in der SIM-Karte 9 können dann automatisch eine Kurzmeldung für den Server 13 vorbereiten, wenn Kaufsbeziehungsweise Verkaufssignale entstehen. Der Benutzer hat dann die Wahl, einen entsprechenden Prozess durchzuführen.

25 Das Benutzerprofil kann im Data-Warehouse 14 vom Benutzer selbst oder durch Kombination erstellt werden. Mit einem persönlichen Benutzerprofil wird es möglich, einem Benutzer gezielt die Produkte anzuzeigen, für die er sich auch wirklich interessiert.

Der Benutzer kann beispielsweise durch eine Kurzmeldung eine
30 Liste von Profilen und Detailsegmenten vom 12 anfordern, die auf seinem

Bildschirm 90 angezeigt wird. Alternativ kann auch ein Benutzerprofil online mit einem PC oder mit einem Rechner bestellt werden. Das bestellte Benutzerprofil wird zum Beispiel in einer Benutzerprofiletabelle im gesicherten Bereich der SIM-Karte 94 abgespeichert und dient der Selektion von Applets, die die
5 interessanten Information enthalten. Die Benutzerprofiletabelle ist vorzugsweise vom Benutzer nicht direkt über das Mobilgerät veränderbar.

Das Feld 525 enthält nur einen Bezeichner F für die Auftragsnummer 52. Die Felder 526, 527 und 528 enthalten Trenner. Das Feld 521 enthält eine Produktlieferantenangabe für das angebotenen Produkt oder
10 für die angebotene Information. Dieser Bezeichner besteht vorzugsweise aus einer vordefinierten Abkürzung des Lieferantennamens. Damit der Benutzer diese Abkürzung verstehen kann, wird vorzugsweise im Applet 50 der komplette Lieferantename als Linkfile mitübertragen (500).

Das Feld 522 enthält die Produktidentifizierung, zum Beispiel eine
15 Produktnummer. Das angebotene Produkt entspricht vorzugsweise dem gleichzeitig ausgesandten Sendeblock 4. Wird zum Beispiel ein Musikstück im FM-Kanal gesandt, können gleichzeitig im Datenkanal oder bei DAB verschiedene dem Musikstück entsprechende Produkte als Option in einem Menü angeboten werden, zum Beispiel das Bestellen einer CD, oder von
20 Musiknoten, oder von Eintrittskarten für ein Konzert, usw. Dieser vom Studio 1 gesteuerte Mechanismus kann auch dynamisch gestaltet werden.

Vorzugsweise wird zusätzlich zur Produktnummer 522 ein Linkfile 501 zu einer oder mehreren Produktidentifizierungen 502, 502', usw. im Klartext und in mehreren Sprachen im Applet 50 übertragen und
25 gegebenenfalls auf dem Display 90 des Empfangssystem 9 angezeigt. Die Produktidentifizierung ist vorzugsweise mit einem Sprachflag 503, 503' usw. versehen. Damit wird ermöglicht, dass die Produktbezeichnung mit dem Sprachflag auf der benutzerspezifischen Java-SIM-Karte auf die Sprache des Benutzers gesetzt werden kann.

30 Das Feld 523 (CS) enthält eine Checksumme oder eine Paritätssumme, um allfällige Fehler im Feld 52 abzufangen. Tritt ein solcher

Fehler auf der Ebene des Servers 13 auf, wird der Benutzer aufgefordert, seine Eingabe zu wiederholen.

Die Checksumme wird festgelegt durch irgendeinen bekannten Fehlerprüfungs- oder Fehlerkorrektur-Algorithmus aus den Feldern 521 und 522. Z.B. kann zum Festlegen des Wertes der Checksumme 523 ein Paritätskontrollealgorithmus verwendet werden. Die Anzahl der Zeichen der Checksumme hängt vom benützten Algorithmus und von der maximal akzeptierten Fehlerquote ab.

Das Feld 524 schliesslich enthält eine Angabe über die gewünschte Transaktion. Dieser Prozess kann interaktiv vom Benutzer gesteuert werden, um einzugeben, ob er ein Produkt bestellen möchte (Order), oder ob er beispielsweise nur Informationen anfordern möchte. Wenn das Empfangssystem auch mit dem Internet vernetzt ist, kann auch ein Code W eingegeben werden, um das Gerät direkt auf eine entsprechende WEB-Seite einzustellen. Mit einer Endgerätidentifikation IMEI im Empfangssystem kann das JAVA-Applet erkennen, ob das System Zugriff auf das Internet hat und ob der W-optioncode auch angeboten werden muss.

Ferner kann mit Optionen im Feld 524 die gewünschte Produktmenge (M) sowie die bevorzugte Zahlungsart (Z) ausgewählt werden.

Diese Informationsaufteilung in der Auftragskurzmeldung wird nur als Beispiel angegeben, denn andere Aufteilungen sind durchaus denkbar. Ausserdem können die verschiedenen Datenfelder vermischt, verschlüsselt und/oder signiert werden, um die Vertraulichkeit zu garantieren. Die Informationen können auch, aufgeteilt in verschiedene Kurzmeldungen, aufeinanderfolgend gesandt werden.

Die Figur 3 zeigt schematisch den Bildschirm 90 bei der Ausführung einer Meldung, welche das Filter passierte. In diesem Beispiel wird die gesamte Auftragsnummer 52 interaktiv dargestellt. Unter dem abgekürzten Lieferantenbezeichner 521 wird die vollständige Lieferantenidentifizierung 500 angezeigt. Mit einem Cursor 900 kann der Benutzer eines von mehreren

Produkten 522, 522', 522'',... in einer Listbox im Bereich 901 auswählen. Die Bezeichnung des angewählten Produktes wird ständig im Klartext im Feld 502 dargestellt. Ähnlich erlaubt das JAVA-Applet eine Auswahl der Transaktionmöglichkeiten (Bestellung oder Information), der gewünschten Menge (M) und der Zahlungsart (Z) mit einem Menü, wobei die angewählte Option stets im Klartext im Textbereich 902 des Bildschirms erläutert wird.

Wir werden jetzt den Prozessablauf näher beschreiben. Im Fall eines Mobilgerätes, das mit einem Radioempfänger kombiniert wird, werden Werbesendungen, Musikdarbietung, Informationen, etc. durch den Broadcastkanal 7 ausgesandt. Gleichzeitig wird auch im verfügbaren Datenkanal die Auftragsnummer 52, vorzugsweise mit Applet 50 verpackt, ausgesandt. Ist der Benutzer von einem Angebot oder von einem Musikstück angesprochen, kann er auf die F-Taste 92 drücken, um die Ausführung des Applets und die Bildschirmanzeige von Figur 3 zu aktivieren. Mit dem Cursor kann der Benutzer dann eine Option zum Beispiel in den Listboxen auswählen und auf diese Weise einen Befehl eingeben ; je nach Lieferant kann auch nur eine einzige Option, zum Beispiel ein einziges Produkt, das man nur bestellen kann, angezeigt werden.

Wählt der Benutzer einen Transaktionscode, der nicht nur Informationen beriff, folgt vorzugsweise ein interaktiver Prozess, damit die Authentizität des Benutzers gesichert werden kann. Dieser Prozess kann direkt auf der Karte 94 erfolgen, zum Beispiel mittels TTP- (Trusted Third Party) oder PTP- (Point to Point) Ressourcen auf der Karte, oder interaktiv in einem nicht dargestellten Security Server.

Im Fall eines Mobilgeräts, das mit einem Fernsehempfänger oder mit einem multifunktionalen Rechner kombiniert ist, läuft der Prozess analog. In diesem Fall kann aber das Empfangssystem auch mit dem Internet vernetzt sein, und WEB-Seiten darstellen. Damit kann das System direkt auf die entsprechende Web-Seite eingestellt werden.

Das erfindungsgemässe Verfahren kann auch mit ganz normalen Mobilgeräten, die keinen zusätzlichen Broadcastkanalempfänger enthalten,

angewendet werden, wie schon mit dem Pfeil 15 auf Figur 1 angedeutet. In diesem Fall werden Meldungen von einer Zentrale 2 durch das normale Mobilfunknetz 8 im Broadcastverfahren an mehrere oder alle Benutzer ausgesandt. In dieser Variante ist es sinnvoll, mit Benutzerprofilen zu arbeiten, damit die Information nur an die dafür interessierten Benutzer gelangt, beziehungsweise nur an solche, die einen entsprechenden Dienst abonniert haben.

Wir werden jetzt mit Hilfe der Figur 4 das Verfahren beschreiben, das im Empfangssystem 9 beim Empfang einer Meldung 5 ausgeführt wird.

Das Empfangssystem verfügt über Empfangsmittel, um ein durch einen Broadcastkanal ausgesandtes Mediaprogramm und programmbegleitende Daten zu empfangen, und über Wiedergabemittel, um das empfangene Mediaprogramm dem Benutzer wiederzugeben. Damit kann das Empfangssystem als programmbegleitende Daten übertragene Meldungen 5 und Applets 50 empfangen (Schritt 20).

Die empfangenen Meldungen 5 werden dann ausgewertet, wobei diese Auswertung bereits erfolgt, wenn der Mobilfunkteil des Empfangssystems ausgeschaltet oder im Stand-by-Modus ist. Wird eine Meldung mit einer Auftragsnummer 52 empfangen (bezeichnet mit dem Bezeichner 525), wird das Benutzerprofil ausgewertet (Test 21). Wenn die empfangene Auftragsnummer keinem Kundenprofil entspricht, wird der Prozess beendet (Schritt 23) ; sonst wird dieser Code weiterbearbeitet. Ist das Mobilgerät eingeschaltet (Test 24), wird das Applet 50 direkt ausgeführt und die übermittelte Information gemäss Figur 3 direkt auf der Anzeige 90 angezeigt (Schritt 25). Der Benutzer kann dann, wie oben beschrieben, zum Beispiel Produkte bestellen oder Informationen anfordern (Schritt 29).

Ist das Mobilgerät dagegen ausgeschaltet, wird die empfangene Meldung 5 oder nur das Applet 50 in einem nicht dargestellten Buffer auf der SIM-Karte 94 oder im Empfangssystem 9 abgelegt (Schritt 26). Erst wenn das Mobilgerät später eingeschaltet wird (Schritt 27), wird das Applet 50 ausgeführt

und die Information angezeigt (Schritt 28), damit der Benutzer Produkte bestellen oder Informationen anfordern kann (Schritt 29).

Ansprüche

1. Telekommunikationsverfahren, das folgende Schritte umfasst:

Empfang von in einem Broadcastkanal (7; 8) ausgesandten digitalen
5 Daten (5) durch ein geeignetes Empfangssystem (9), wobei das
Empfangssystem eine Identifizierungskarte (94) umfasst, mit der der Benutzer
des Empfangssystems identifiziert wird,

Anzeige von Informationen, die den empfangenen digitalen Daten
entsprechen, auf einer Anzeige (90) des Empfangssystems,

10 Eingabe eines Befehls durch den Benutzer,

Vorbereitung einer dem eingegebenen Befehl entsprechenden
Meldung, wobei die vorbereitete Meldung mindestens ein Datenfeld (521, 522,
524) aus den empfangenen digitalen Daten (5) sowie eine aus der
Identifizierungskarte ermittelte Identifizierung des Benutzers umfasst,

15 Sendung der vorbereiteten Meldung durch ein bidirektionales
Telekommunikationsnetz (8).

2. Telekommunikationsverfahren gemäss Anspruch 1, dadurch
gekennzeichnet, dass die genannten digitalen Daten als programmbegleitende
digitalen Daten (5) in einem Mediaprogramm (4) übertragen werden, und dass
20 das genannte bidirektionale Telekommunikationsnetz ein Mobilfunknetz ist.

3. Telekommunikationsverfahren gemäss Anspruch 2, dadurch
gekennzeichnet, dass das genannte Mediaprogramm (4) vom Empfangssystem
(9) wiedergegeben wird.

4. Telekommunikationsverfahren gemäss einem der vorhergehenden Ansprüche, dadurch gekennzeichnet, dass die angezeigten Informationen mindestens ein Menü enthalten, aus dem ein Befehl ausgewählt werden kann.

5. Telekommunikationsverfahren gemäss einem der vorhergehenden Ansprüche, dadurch gekennzeichnet, dass die digitalen Daten Applets (50) enthalten können, die vom Empfangssystem (9) ausgeführt werden.

6. Telekommunikationsverfahren gemäss einem der vorhergehenden Ansprüche, dadurch gekennzeichnet, dass, wenn die zur Bearbeitung und Anzeige dieser Daten benötigten Komponenten ausgeschaltet sind, die empfangenen digitalen Daten in einem Buffer zwischengespeichert werden und erst beim Einschalten dieser Komponenten bearbeitet werden.

7. Telekommunikationsverfahren gemäss einem der vorhergehenden Ansprüche, dadurch gekennzeichnet, dass die empfangenen digitalen Daten in Meldungen (5) verpackt werden, die zuerst ausgewertet werden, um festzustellen, ob sie angezeigt werden müssen.

8. Telekommunikationsverfahren gemäss Anspruch 7, dadurch gekennzeichnet, dass die empfangenen Meldungen (5), die nicht dem Interesse des Benutzers entsprechen, mit Hilfe eines im Speicherbereich des Empfangssystems (9) gespeicherten Benutzerprofils aussortiert werden.

9. Telekommunikationsverfahren gemäss einem der vorhergehenden Ansprüche, dadurch gekennzeichnet, dass der Broadcastkanal (7) ein Radiokanal ist.

10. Telekommunikationsverfahren gemäss einem der Ansprüche 1 bis 9, dadurch gekennzeichnet, dass der Broadcastkanal (7) ein TV-Kanal ist.

11. Telekommunikationsverfahren gemäss einem der vorhergehenden Ansprüche, dadurch gekennzeichnet, dass die vorbereitete Meldung eine SMS-Meldung ist.

12. Telekommunikationsverfahren gemäss einem der vorhergehenden Ansprüche, dadurch gekennzeichnet, dass die vorbereitete Meldung eine USSD-Meldung ist.

5 13. Telekommunikationsverfahren gemäss einem der vorhergehenden Ansprüche, dadurch gekennzeichnet, dass die vorbereitete Meldung signiert wird.

14. Telekommunikationsverfahren gemäss einem der vorhergehenden Ansprüche, dadurch gekennzeichnet, dass die vorbereitete Meldung verschlüsselt wird.

10 15. Empfangssystem, umfassend :

Empfangsmittel, um ein durch einen Broadcastkanal (7; 8) ausgesandtes Mediaprogramm (4) und programmbegleitende Daten (5) zu empfangen,

15 Wiedergabemittel (90, 95), um das empfangene Mediaprogramm dem Benutzer wiederzugeben,

eine Identifizierungskarte (94), um den Benutzer des Empfangssystems (9) zu identifizieren,

Mobilfunkkomponenten, mit denen das Empfangssystem (9) in einem Mobilfunknetz (8) eingesetzt werden kann,

20 Meldungsvorbereitungsmittel, um Meldungen, die mindestens ein Datenfeld (521, 522, 524) aus den programmbegleitenden Daten (5) sowie eine Identifizierung des Benutzers umfassen, vorzubereiten und in das Mobilfunknetz (8) zu senden.

25 16. Empfangssystem gemäss Anspruch 15, dadurch gekennzeichnet, dass die benannten Empfangsmittel einen Radioempfänger umfassen.

17. Empfangssystem gemäss Anspruch 15, dadurch gekennzeichnet, dass die benannten Empfangsmittel einen Fernsehempfänger umfassen.

5 18. Empfangssystem gemäss einem der Ansprüche 15 bis 17, dadurch gekennzeichnet, dass die Mobilfunkkomponenten ein GSM-Mobilgerät umfassen.

10 19. Empfangssystem gemäss einem der Ansprüche 15 bis 18, dadurch gekennzeichnet, dass die Identifizierungskarte eine SIM-Karte (94) ist, die in den programmbegleitenden Daten (5) übertragene Applets (50) ausführen kann.

20. Empfangssystem gemäss einem der Ansprüche 15 bis 19, dadurch gekennzeichnet, dass die Meldungsvorbereitungsmittel SMS-Meldungen vorbereiten und senden können.

15 21. Empfangssystem gemäss einem der Ansprüche 15 bis 20, dadurch gekennzeichnet, dass die Meldungsvorbereitungsmittel USSD-Meldungen vorbereiten und senden können.

20 22. Empfangssystem gemäss einem der Ansprüche 15 bis 21, dadurch gekennzeichnet, dass es eine Taste (92) umfasst, um die Anzeige von Informationen, die den empfangenen digitalen Daten entsprechen, auf einer Anzeige (90) des Empfangssystems zu veranlassen.

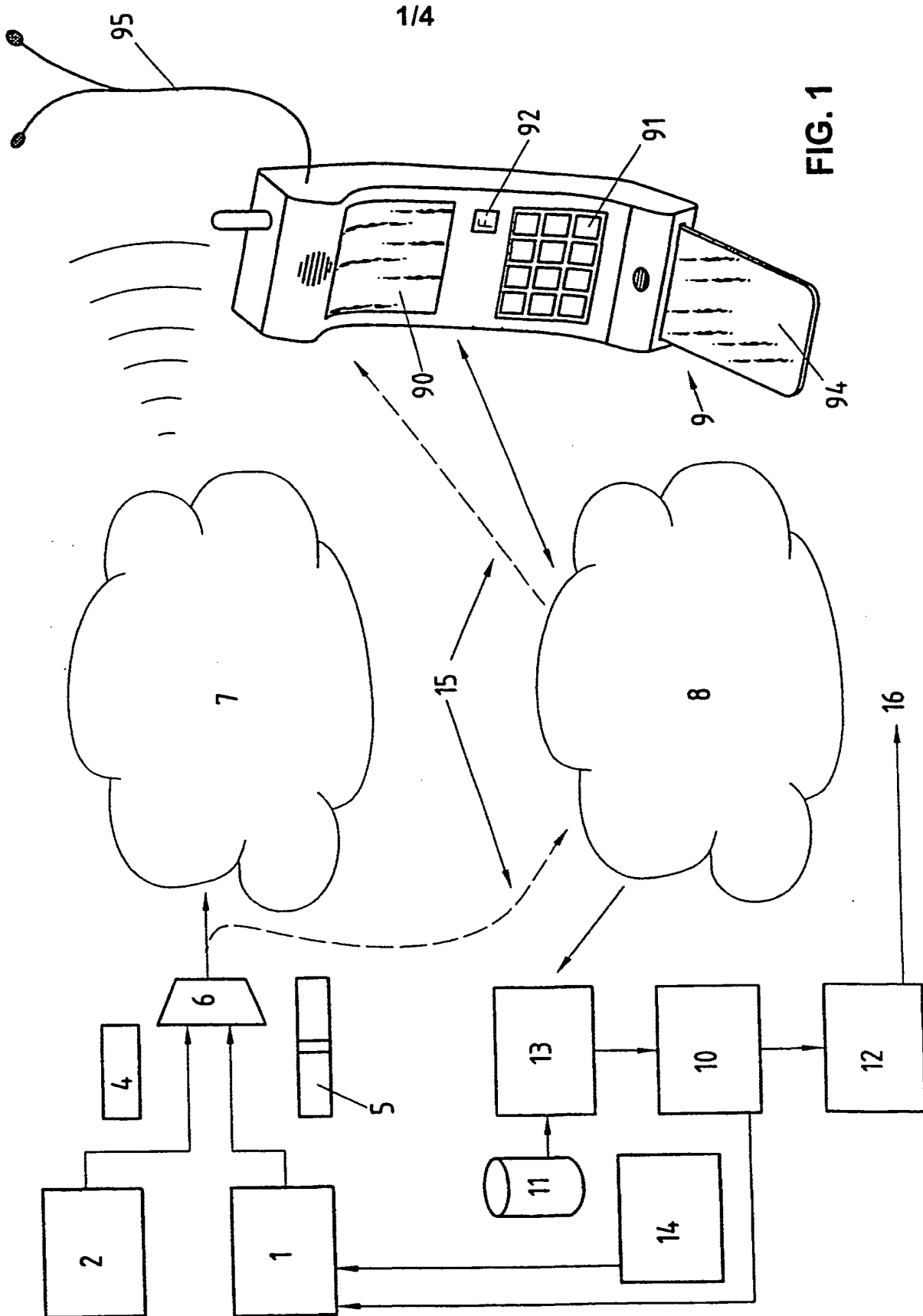

FIG. 1

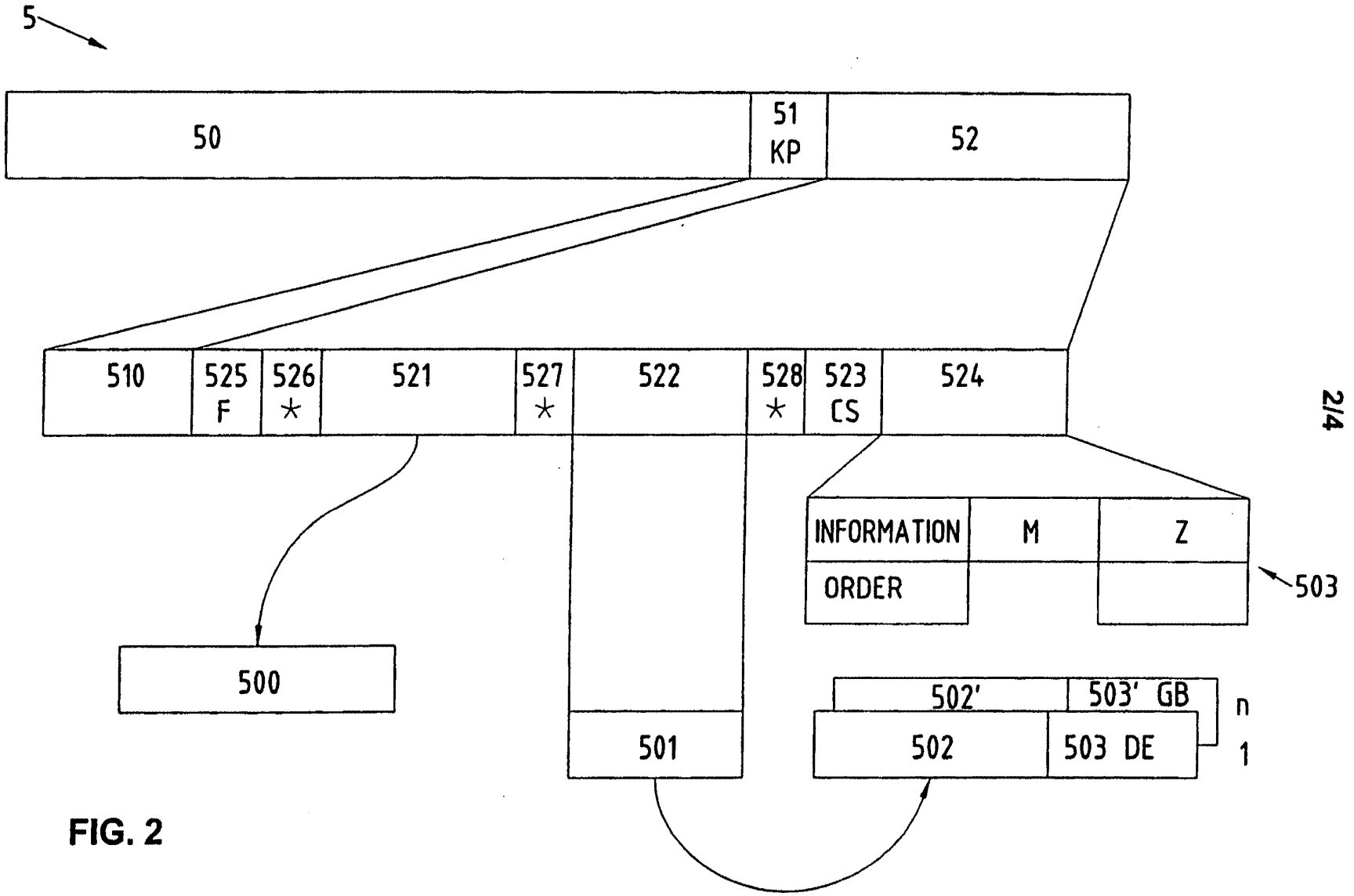
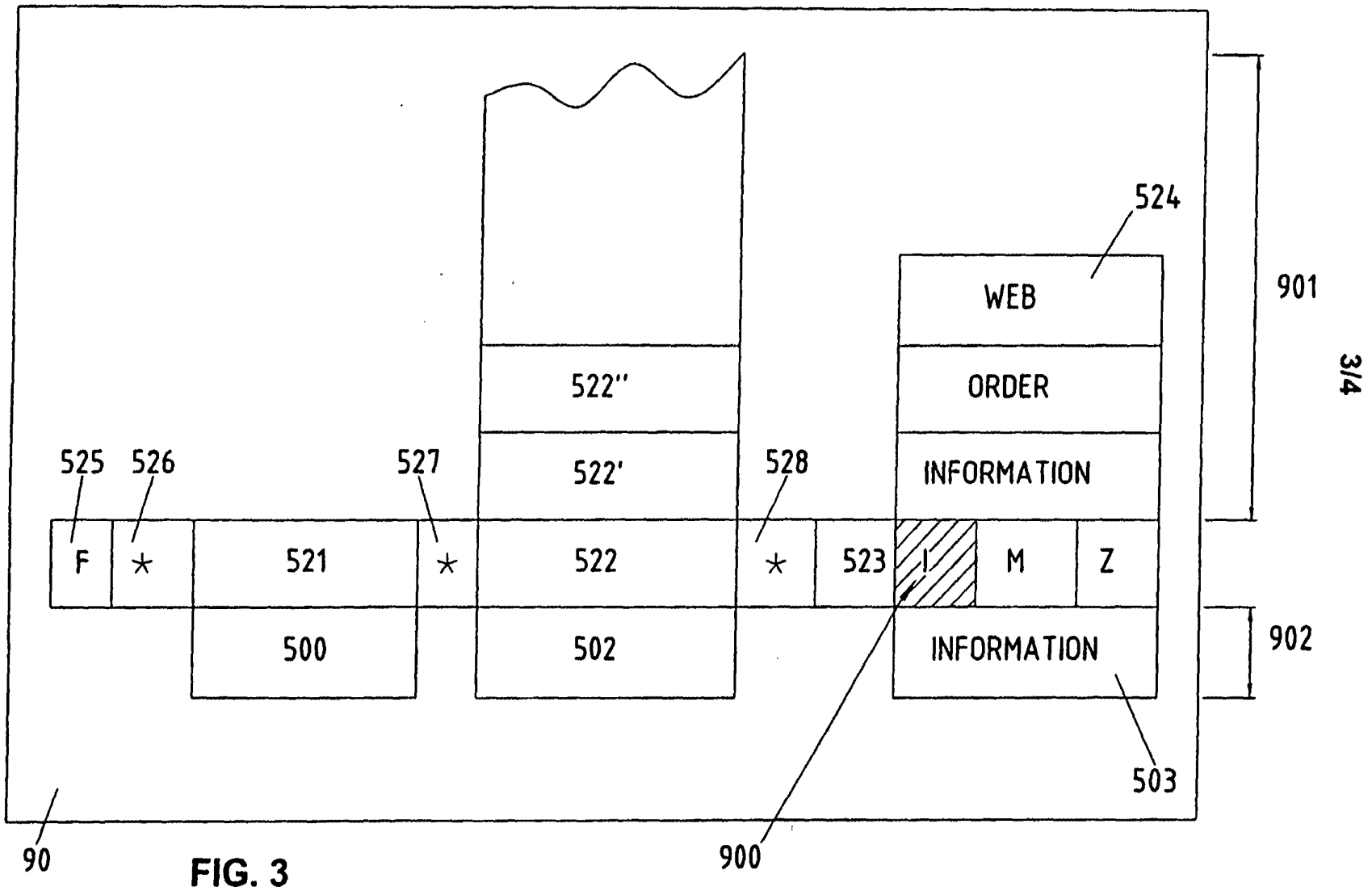

FIG. 2



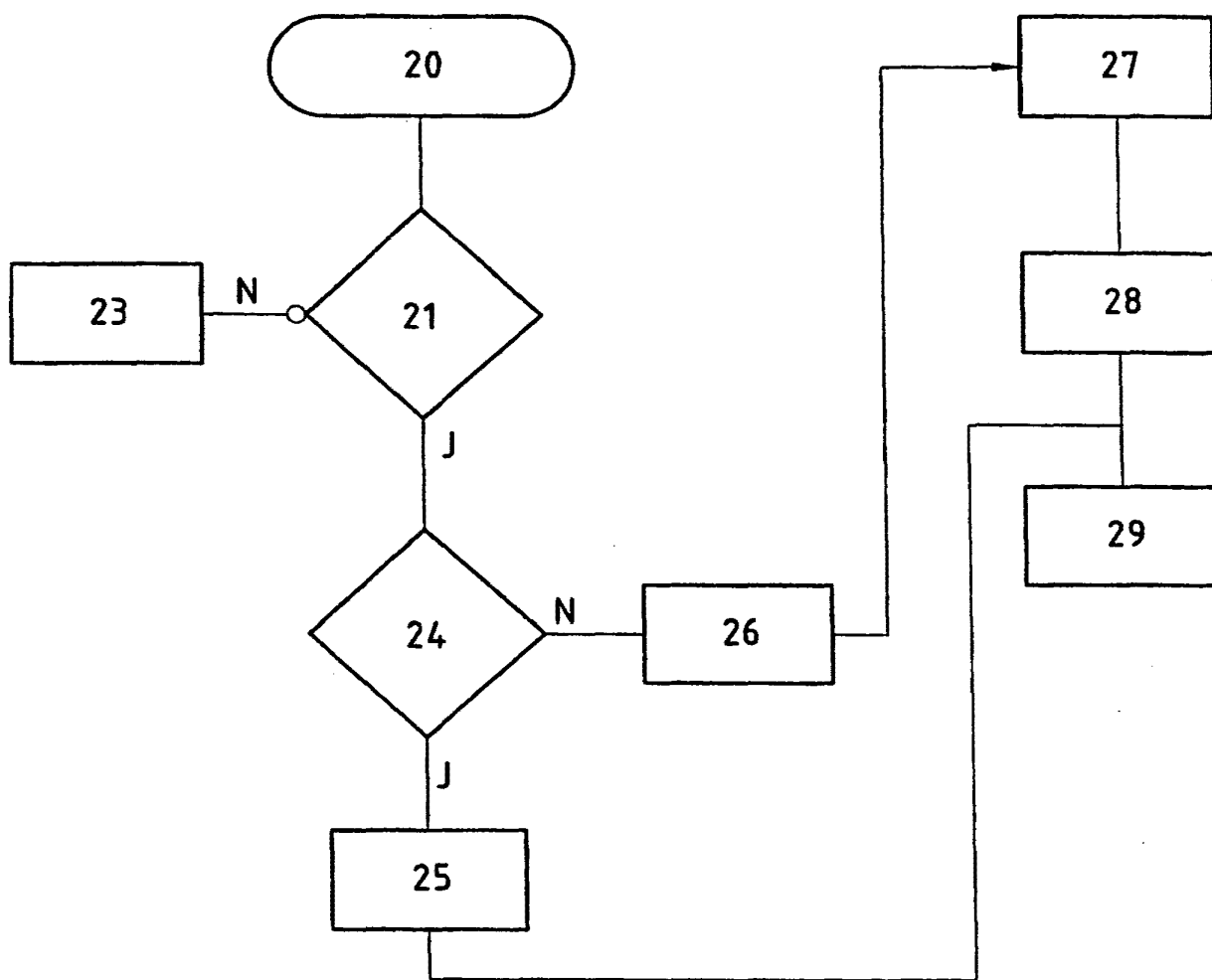

FIG. 4

INTERNATIONAL SEARCH REPORT

International Application No
PCT/CH 99/00006

A. CLASSIFICATION OF SUBJECT MATTER
IPC 6 H04H9/00

According to International Patent Classification (IPC) or to both national classification and IPC

B. FIELDS SEARCHED

Minimum documentation searched (classification system followed by classification symbols)
IPC 6 H04H

Documentation searched other than minimum documentation to the extent that such documents are included in the fields searched

Electronic data base consulted during the international search (name of data base and, where practical, search terms used)

C. DOCUMENTS CONSIDERED TO BE RELEVANT

| Category | Citation of document, with indication, where appropriate, of the relevant passages | Relevant to claim No. |
|----------|---|-----------------------|
| A | EP 0 426 542 A (EUROP RECH ELECTR LAB) 8 May 1991 see column 1, line 1 - column 4, line 19; claims 1,13; figure 1 --- | 1, 15 |
| A | WO 97 40616 A (GEMPLUS CARD INT) 30 October 1997 see page 1, line 1 - page 15, line 12; claim 1; figure 1 --- | 1, 15 |
| A | WO 95 15654 A (ZING SYSTEMS L P) 8 June 1995 see page 1, line 1 - page 10, line 26; claims 1,17,21,25,28,33,37,39; figure 1 --- | 1, 15 |
| | -/-- | |

Further documents are listed in the continuation of box C.

Patent family members are listed in annex.

* Special categories of cited documents :

- "A" document defining the general state of the art which is not considered to be of particular relevance
- "E" earlier document but published on or after the international filing date
- "L" document which may throw doubts on priority claim(s) or which is cited to establish the publication date of another citation or other special reason (as specified)
- "O" document referring to an oral disclosure, use, exhibition or other means
- "P" document published prior to the international filing date but later than the priority date claimed

- "T" later document published after the international filing date or priority date and not in conflict with the application but cited to understand the principle or theory underlying the invention
- "X" document of particular relevance; the claimed invention cannot be considered novel or cannot be considered to involve an inventive step when the document is taken alone
- "Y" document of particular relevance; the claimed invention cannot be considered to involve an inventive step when the document is combined with one or more other such documents, such combination being obvious to a person skilled in the art.
- "&" document member of the same patent family

Date of the actual completion of the international search

Date of mailing of the international search report

9 April 1999

28/04/1999

Name and mailing address of the ISA
European Patent Office, P.B. 5818 Patentlaan 2
NL - 2280 HV Rijswijk
Tel. (+31-70) 340-2040, Tx. 31 651 epo nl,
Fax: (+31-70) 340-3016

Authorized officer

De Haan, A.J.

INTERNATIONAL SEARCH REPORT

International Application No
PCT/CH 99/00006

C.(Continuation) DOCUMENTS CONSIDERED TO BE RELEVANT

| Category | Citation of document, with indication, where appropriate, of the relevant passages | Relevant to claim No. |
|----------|---|-----------------------|
| A | US 5 444 769 A (KOEN JACOBUS P L ET AL) 22 August 1995 see column 1, line 1 - column 2, line 10; claims 1,4; figure 1 ----- | 1,15 |

INTERNATIONAL SEARCH REPORT

Information on patent family members

International Application No

PCT/CH 99/00006

| Patent document cited in search report | | Publication date | Patent family member(s) | Publication date |
|--|---|------------------|-------------------------|------------------|
| EP 0426542 | A | 08-05-1991 | FR 2654286 | A 10-05-1991 |
| | | | DE 69029835 | D 13-03-1997 |
| | | | DE 69029835 | T 28-05-1997 |
| | | | MX 171750 | B 11-11-1993 |
| | | | NZ 235927 | A 25-03-1994 |
| | | | US 5173589 | A 22-12-1992 |
| | | | US 5173589 | A 22-12-1992 |
| WO 9740616 | A | 30-10-1997 | AU 2401397 | A 12-11-1997 |
| | | | CA 2252526 | A 30-10-1997 |
| | | | EP 0894397 | A 03-02-1999 |
| WO 9515654 | A | 08-06-1995 | US 5734413 | A 31-03-1998 |
| | | | AU 1292895 | A 19-06-1995 |
| | | | EP 0740884 | A 06-11-1996 |
| | | | US 5638113 | A 10-06-1997 |
| US 5444769 | A | 22-08-1995 | GB 2295746 | A 05-06-1996 |
| | | | ZA 9209925 | A 21-09-1996 |

INTERNATIONALER RECHERCHENBERICHT

Internationales Aktenzeichen

PCT/CH 99/00006

A. KLASSIFIZIERUNG DES ANMELDUNGSGEGENSTANDES
 IPK 6 H04H9/00

Nach der Internationalen Patentklassifikation (IPK) oder nach der nationalen Klassifikation und der IPK

B. RECHERCHIERTE GEBIETE

Recherchiertes Mindestprüfstoff (Klassifikationssystem und Klassifikationssymbole)

IPK 6 H04H

Recherchierte aber nicht zum Mindestprüfstoff gehörende Veröffentlichungen, soweit diese unter die recherchierten Gebiete fallen

Während der internationalen Recherche konsultierte elektronische Datenbank (Name der Datenbank und evtl. verwendete Suchbegriffe)

C. ALS WESENTLICH ANGESEHENE UNTERLAGEN

| Kategorie* | Bezeichnung der Veröffentlichung, soweit erforderlich unter Angabe der in Betracht kommenden Teile | Betr. Anspruch Nr. |
|------------|---|--------------------|
| A | EP 0 426 542 A (EUROP RECH ELECTR LAB) 8. Mai 1991 siehe Spalte 1, Zeile 1 - Spalte 4, Zeile 19; Ansprüche 1,13; Abbildung 1 --- | 1, 15 |
| A | WO 97 40616 A (GEMPLUS CARD INT) 30. Oktober 1997 siehe Seite 1, Zeile 1 - Seite 15, Zeile 12; Anspruch 1; Abbildung 1 --- | 1, 15 |
| A | WO 95 15654 A (ZING SYSTEMS L P) 8. Juni 1995 siehe Seite 1, Zeile 1 - Seite 10, Zeile 26; Ansprüche 1,17,21,25,28,33,37,39; Abbildung 1 --- -/-- | 1, 15 |

Weitere Veröffentlichungen sind der Fortsetzung von Feld C zu entnehmen

Siehe Anhang Patentfamilie

* Besondere Kategorien von angegebenen Veröffentlichungen :

"A" Veröffentlichung, die den allgemeinen Stand der Technik definiert, aber nicht als besonders bedeutsam anzusehen ist

"E" älteres Dokument, das jedoch erst am oder nach dem internationalen Anmeldedatum veröffentlicht worden ist

"L" Veröffentlichung, die geeignet ist, einen Prioritätsanspruch zweifelhaft erscheinen zu lassen, oder durch die das Veröffentlichungsdatum einer anderen im Recherchenbericht genannten Veröffentlichung belegt werden soll oder die aus einem anderen besonderen Grund angegeben ist (wie ausgeführt)

"O" Veröffentlichung, die sich auf eine mündliche Offenbarung, eine Benutzung, eine Ausstellung oder andere Maßnahmen bezieht

"P" Veröffentlichung, die vor dem internationalen Anmeldedatum, aber nach dem beanspruchten Prioritätsdatum veröffentlicht worden ist

"T" Spätere Veröffentlichung, die nach dem internationalen Anmeldedatum oder dem Prioritätsdatum veröffentlicht worden ist und mit der Anmeldung nicht kollidiert, sondern nur zum Verständnis des der Erfindung zugrundeliegenden Prinzips oder der ihr zugrundeliegenden Theorie angegeben ist

"X" Veröffentlichung von besonderer Bedeutung; die beanspruchte Erfindung kann allein aufgrund dieser Veröffentlichung nicht als neu oder auf erfinderischer Tätigkeit beruhend betrachtet werden

"Y" Veröffentlichung von besonderer Bedeutung; die beanspruchte Erfindung kann nicht als auf erfinderischer Tätigkeit beruhend betrachtet werden, wenn die Veröffentlichung mit einer oder mehreren anderen Veröffentlichungen dieser Kategorie in Verbindung gebracht wird und diese Verbindung für einen Fachmann naheliegend ist

"&" Veröffentlichung, die Mitglied derselben Patentfamilie ist

Datum des Abschlusses der internationalen Recherche

9. April 1999

Absenddatum des internationalen Recherchenberichts

28/04/1999

Name und Postanschrift der Internationalen Recherchenbehörde
 Europäisches Patentamt, P.B. 5818 Patentlaan 2
 NL - 2280 HV Rijswijk
 Tel. (+31-70) 340-2040, Tx. 31 651 epo nl,
 Fax: (+31-70) 340-3016

Bevollmächtigter Bediensteter

De Haan, A.J.

INTERNATIONALER RECHERCHENBERICHT

Internationales Aktenzeichen

PCT/CH 99/00006

C.(Fortsetzung) ALS WESENTLICH ANGESEHENE UNTERLAGEN

| Kategorie | Bezeichnung der Veröffentlichung, soweit erforderlich unter Angabe der in Betracht kommenden Teile | Betr. Anspruch Nr. |
|-----------|--|--------------------|
| A | US 5 444 769 A (KOEN JACOBUS P L ET AL) 22. August 1995 siehe Spalte 1, Zeile 1 - Spalte 2, Zeile 10; Ansprüche 1,4; Abbildung 1 ----- | 1,15 |

INTERNATIONALER RECHERCHENBERICHT

Angaben zu Veröffentlichungen, die zur selben Patentfamilie gehören

Internationales Aktenzeichen

PCT/CH 99/00006

| Im Recherchenbericht angeführtes Patentdokument | Datum der Veröffentlichung | Mitglied(er) der Patentfamilie | Datum der Veröffentlichung |
|--|-------------------------------|-----------------------------------|-------------------------------|
| EP 0426542 A | 08-05-1991 | FR 2654286 A | 10-05-1991 |
| | | DE 69029835 D | 13-03-1997 |
| | | DE 69029835 T | 28-05-1997 |
| | | MX 171750 B | 11-11-1993 |
| | | NZ 235927 A | 25-03-1994 |
| | | US 5173589 A | 22-12-1992 |
| WO 9740616 A | 30-10-1997 | AU 2401397 A | 12-11-1997 |
| | | CA 2252526 A | 30-10-1997 |
| | | EP 0894397 A | 03-02-1999 |
| WO 9515654 A | 08-06-1995 | US 5734413 A | 31-03-1998 |
| | | AU 1292895 A | 19-06-1995 |
| | | EP 0740884 A | 06-11-1996 |
| | | US 5638113 A | 10-06-1997 |
| US 5444769 A | 22-08-1995 | GB 2295746 A | 05-06-1996 |
| | | ZA 9209925 A | 21-09-1996 |



INTERNATIONAL APPLICATION PUBLISHED UNDER THE PATENT COOPERATION TREATY (PCT)

| | | |
|---|------------------|---|
| <p>(51) International Patent Classification ⁶ : H04H 1/00</p> | <p>A1</p> | <p>(11) International Publication Number: WO 99/43109 (43) International Publication Date: 26 August 1999 (26.08.99)</p> |
| <p>(21) International Application Number: PCT/GB99/00514 (22) International Filing Date: 18 February 1999 (18.02.99) (30) Priority Data: 9803623.9 20 February 1998 (20.02.98) GB (71) Applicant (for all designated States except US): TTP COMMUNICATIONS LIMITED [GB/GB]; Melbourn Science Park, Cambridge Road, Melbourn, Royston, Hertfordshire SG8 6EE (GB). (72) Inventor; and (75) Inventor/Applicant (for US only): JOHNSON, Nicholas, Dougall [GB/GB]; 24 Camp Road, St. Albans, Hertfordshire AL1 5DY (GB). (74) Agent: GILL JENNINGS & EVERY; Broadgate House, 7 Eldon Street, London EC2M 7LH (GB).</p> | | <p>(81) Designated States: AL, AM, AT, AU, AZ, BA, BB, BG, BR, BY, CA, CH, CN, CU, CZ, DE, DK, EE, ES, FI, GB, GD, GE, GH, GM, HR, HU, ID, IL, IN, IS, JP, KE, KG, KP, KR, KZ, LC, LK, LR, LS, LT, LU, LV, MD, MG, MK, MN, MW, MX, NO, NZ, PL, PT, RO, RU, SD, SE, SG, SI, SK, SL, TJ, TM, TR, TT, UA, UG, US, UZ, VN, YU, ZW, ARIPO patent (GH, GM, KE, LS, MW, SD, SZ, UG, ZW), Eurasian patent (AM, AZ, BY, KG, KZ, MD, RU, TJ, TM), European patent (AT, BE, CH, CY, DE, DK, ES, FI, FR, GB, GR, IE, IT, LU, MC, NL, PT, SE), OAPI patent (BF, BJ, CF, CG, CI, CM, GA, GN, GW, ML, MR, NE, SN, TD, TG).</p> <p>Published With international search report.</p> |

(54) Title: METHOD AND SYSTEM FOR TRANSMITTING AUDIO DATA TOGETHER WITH OTHER DATA, COMPRISING ADDRESSING DATA, TO A RECEIVER

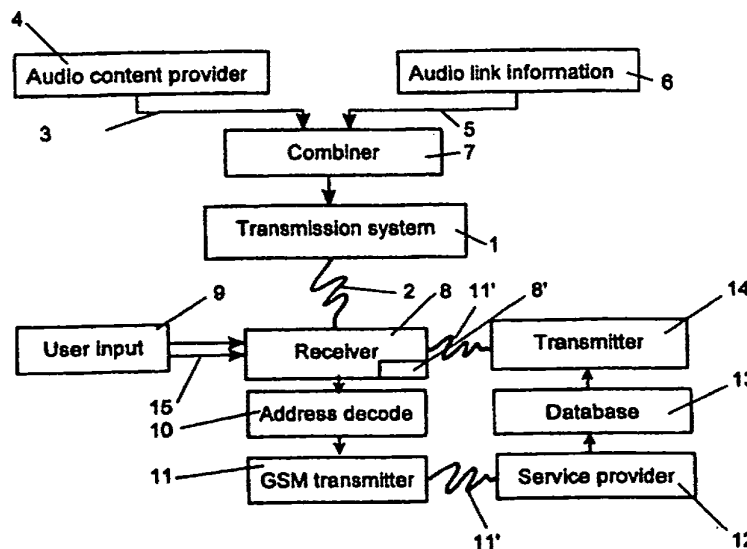

(57) Abstract

The present invention concerns a method for transmitting audio information to a receiver, in which first audio information is transmitted from a first source to the receiver together with other information comprising addressing data and a data signal dependent on the addressing data is selectively transmitted from the receiver to a service provider. The data signal received at the service provider is matched with respective further audio information and the respective further audio information is then transmitted from a second source to the receiver. Thus, a web of recursively linked audio material may selectively be provided to a user of the receiver.

FOR THE PURPOSES OF INFORMATION ONLY

Codes used to identify States party to the PCT on the front pages of pamphlets publishing international applications under the PCT.

| | | | | | | | |
|----|--------------------------|----|--|----|--|----|--------------------------|
| AL | Albania | ES | Spain | LS | Lesotho | SI | Slovenia |
| AM | Armenia | FI | Finland | LT | Lithuania | SK | Slovakia |
| AT | Austria | FR | France | LU | Luxembourg | SN | Senegal |
| AU | Australia | GA | Gabon | LV | Latvia | SZ | Swaziland |
| AZ | Azerbaijan | GB | United Kingdom | MC | Monaco | TD | Chad |
| BA | Bosnia and Herzegovina | GE | Georgia | MD | Republic of Moldova | TG | Togo |
| BB | Barbados | GH | Ghana | MG | Madagascar | TJ | Tajikistan |
| BE | Belgium | GN | Guinea | MK | The former Yugoslav Republic of Macedonia | TM | Turkmenistan |
| BF | Burkina Faso | GR | Greece | | | TR | Turkey |
| BG | Bulgaria | HU | Hungary | ML | Mali | TT | Trinidad and Tobago |
| BJ | Benin | IE | Ireland | MN | Mongolia | UA | Ukraine |
| BR | Brazil | IL | Israel | MR | Mauritania | UG | Uganda |
| BY | Belarus | IS | Iceland | MW | Malawi | US | United States of America |
| CA | Canada | IT | Italy | MX | Mexico | UZ | Uzbekistan |
| CF | Central African Republic | JP | Japan | NE | Niger | VN | Viet Nam |
| CG | Congo | KE | Kenya | NL | Netherlands | YU | Yugoslavia |
| CH | Switzerland | KG | Kyrgyzstan | NO | Norway | ZW | Zimbabwe |
| CI | Côte d'Ivoire | KP | Democratic People's Republic of Korea | NZ | New Zealand | | |
| CM | Cameroon | | | PL | Poland | | |
| CN | China | KR | Republic of Korea | PT | Portugal | | |
| CU | Cuba | KZ | Kazakstan | RO | Romania | | |
| CZ | Czech Republic | LC | Saint Lucia | RU | Russian Federation | | |
| DE | Germany | LI | Liechtenstein | SD | Sudan | | |
| DK | Denmark | LK | Sri Lanka | SE | Sweden | | |
| EE | Estonia | LR | Liberia | SG | Singapore | | |

METHOD AND SYSTEM FOR TRANSMITTING AUDIO DATA TOGETHER WITH OTHER DATA,
COMPRISING ADDRESSING DATA, TO A RECEIVER

The present invention relates to the transmission of audio information and to both a method and system for such transmission.

5 It is known to broadcast data along with audio signals in order to provide interruption of the broadcast audio signal by causing the receiver to retune automatically to a different frequency to receive alternative information such as news or traffic information. The Radio Data System (RDS) has been used for such purpose in Europe for several years. However, although the user is able
10 to select for interruption between certain general types or categories of information, once this selection has been made by the user, the timing of interruption and the information provided are automatically determined by the service providing the information and to which the radio retunes. Whilst such a service is very valuable, it is limited in nature.

15 In order to provide a wider range of information to a radio user, a different system is necessary.

According to the present invention there is provided a method for transmitting audio information to a receiver, comprising:

20 transmitting from a first source to the receiver first audio information together with other information comprising addressing data;

selectively transmitting from the receiver to a service provider a data signal dependent on the addressing data;

matching the data signal received at the service provider with respective further audio information; and

25 transmitting the respective further audio information from a second source to the receiver.

The invention also includes a system for transmitting audio information to a receiver, comprising:

30 a first source for transmitting to the receiver first audio information together with other information comprising addressing data;

means at the receiver for converting the first audio information to an audio signal;

means at the receiver selectively operable for transmitting to a service provider a data signal dependent on the addressing data;

5 comparing means for matching the data signal received at the service provider with respective further audio information;

a second source for transmitting the respective further audio information from the service provider to the receiver; and,

10 means at the receiver for converting the further audio information to an audio signal.

By this method and system a web of recursively linked audio material may selectively be provided to a user of the receiver through the use of appropriate keys at the receiver. The system may be operated by the user to provide further audio information related to the first audio information by
15 extracting the addressing data and transmitting a corresponding data signal, via say a digital mobile telephone network, to a service provider system at which the received addressing data is matched, using a database, with further audio information related to the first audio information, and that further audio information is then transmitted to the receiver. A further key may be used to
20 return the listener to the original audio information transmission or to the previous one.

The system of the invention may use a conventional RDS system to provide the transmission of the further audio information, by causing a transmitter (source) related to the first transmitter (source) to interrupt the
25 reception of the first audio information with the further audio information, but preferably, the system makes use of digital audio broadcasting (DAB) signals to provide the first audio information signal and related addressing data and the further audio information and further addressing data are transmitted by a DAB transmitter related to the transmitter providing the first audio information and
30 addressing data, or else by the mobile telephone link used to transmit the addressing data-related signal to the service provider.

However, the invention is not limited to particular mechanisms or types of transmission of either the audio information and related addressing data nor of the addressing data-related data signal and these could be provided by wireless, wire or cable links. For example the original transmission could be an audio information signal (together with related addressing data) transmitted by an Internet web site.

In order to indicate to a user that there is further audio information related to the first (or subsequent) audio information provided to the user, the audio signal is augmented. This may be achieved in a number of ways and the augmentation may, depending on the method chosen, occur either at the source (ie. to the transmitted audio information) or else at the receiver (ie. to the received audio information before conversion). For example a beep may be inserted at the beginning and end of sections of audio information transmission to indicate to a listener that what follows is capable of being linked to to provide further information. Alternatively, audio processing may be used to give the converted audio signal a particular auditory shade or style. A further possibility is to provide a visual indication on a visual display panel associated with the receiver.

When the user has selected or linked to further audio information, the converted audio signal needs to be separated from the original audio signal to indicate that the listener is now linked to additional material. This may be done in a number of ways. For example, the transmission of audio information may be paused momentarily to indicate the change of content. Alternatively, the audio signals may be superimposed, with the further audio information being more prominent than the original. A still further possibility is to separate the original and further audio signals to left and right stereo channels, with suitable mixing down of the original signal from stereo to mono if necessary. The various type of separation may be selected by the user and they may be combined if desired, the required circuitry for the different types being provided within the receiver.

Three examples of a system according to the present invention will now be described with reference to the accompanying drawings, in which:

Figure 1 is a block diagram of the components of a generalised system;

Figure 2 is a table showing links between related audio information which might be provided by the system;

Figure 3 illustrates the components of a second system; and

Figure 4 illustrates the components of a third system.

The example illustrated in connection with the accompanying Figures 1 and 2 utilises a DAB receiver which incorporates a GSM mobile telephone.

A DAB transmission system 1 provides an audio information broadcast 2, the broadcast 2 comprising both audio information 3 provided from an audio content provider 4 and addressing data 5 provided by an audio link information system 6. The audio information and the addressing data are combined at 7 and fed to the DAB transmission system 1. As is well known, a DAB transmission incorporates a PAD channel and it is the PAD channel which carries the audio link information or addressing data 5.

At a receiver 8 a listener or user is able to activate a key 9 (known as the "Tell Me More" [TMM] key) which causes the addressing information received on the PAD channel to be decoded by a decoder 10 and passed to the GSM telephone 11 which, using the decoded addressing data dials, an appropriate number to a service provider 12. The service provider maintains a database of audio "clips" 13, each one corresponding to corresponding addressing data 5. On receiving the transmission from the GSM transmitter 11 the database is scanned for a match and the corresponding audio clip is transferred from the database to a transmitter 14 which transmits information to the receiver 8. The transmitter 14 may be a separate DAB transmitter or the like, but in the present example it is preferably a GSM transmitter and the information is transmitted back to the receiver through the same call initiated by the user.

The use of the system will now be described in more detail by reference to the table of figure 2.

The example shown in the table of figure 2 comprises a DAB programme 20 which carries a news item, in the example, describing an (imaginary) incident in the Gaza Strip, a portion of the text of which is shown at 21. The DAB PAD channel 30 contains addressing or link information which enables the user to
5 find out more information about the Gaza Strip and on receipt of the PAD channel information at a receiver display 8' (see figure 1) displays the text shown at 31, inviting the listener or user to dial (a given telephone number?) on the GSM telephone 11 to find out more information. In order to avoid the listener having to actually dial the telephone number himself, the addressing
10 data transmitted by the DAB PAD channel is decoded within the decoder 10 and the "Tell Me More button" 9 is effectively "enabled" at 9' so that if the user wishes to obtain further information all he has to do is then press (9") the TMM button.

Operation of the TMM button causes the GSM telephone 11 to establish
15 a GSM link 11' which (11") sets up a call to the service provider 12 as described above. Addressing data within the DAB PAD channel, decoded and transmitted through the GSM link 11', is read at the service provider 12 and matched within the database 13. The corresponding further audio information or "clip" is transmitted by the transmitter 14 using the same GSM call to provide further
20 audio information back to the listener, for example the text shown at 22. The signal transmitted back to the user and containing the audio information 22 may itself contain further links, for example, as illustrated, for further material about the state of Israel and the 6-Day war of 1967 and these are also decoded in the decoder 10 and may be used by the system and through operation of the TMM
25 button 9, to find out further audio information from the service provider 12 or from a separate service provider if the information is held in a different database for example.

The righthand side of the table of figure 2 illustrates the audio output to the user in the textbox 40. It can be seen that at the start of the link information
30 there is a "header" to advise the user that more information is being provided about the chosen subject (in this case the Gaza Strip) and at the end a "footer"

is provided indicating that the audio output is returning to the DAB programme material.

5 The first news item 21 may contain a second or further link, for example, allowing the user to operate the TMM button 9 to find out more information about the "Hammas" organisation. Again the display 8' displays relevant text 32 to the user. The listener may choose not to find out more information about the Gaza Strip, but may decide to find out more about Hammas instead.

10 A second news item 23 may contain its own separate links allowing the user to link to further material held on the service provider database 13 or on the database of a separate service provider.

As described in the introduction to the specification, the presence of addressing data (which defines the presence of a link) may be highlighted in the audio stream to the user by a beep or similar and/or by text signalling in the DAB PAD channel and displayed on the display 8' of the receiver 8.

15 The linked-to material (LTM) is separated from the basic audio programme content 21 or linked-from material (LFM) so that the listener understands where the LTM starts and finishes. This may be achieved by simple replacement after a pause, a similar pause being provided at the end of the LTM, or by superposition, the LFM being mixed down and the LTM added 20 to the audio stream so that the listener hears the LFM and LTM together, with the LTM being more prominent. The listener can still "tune-in" to the LFM if desired and also unconsciously uses it as a indicator of the linked material. A third alternative is stereo separation in which case the LFM (which may already be in stereo) is mixed down to mono if necessary and placed in one direction 25 to say the left stereo channel and the LTM (which owing to GSM bandwidth limits will almost certainly be in mono) is placed in a different direction to say the right stereo channel.

30 All the processing necessary to implement the different styles of presentation of the LTM can be contained within the receiver 8 and may be selectable by the listener as a personal preference or on an instance-by-instance basis.

The apparatus of the example of figure 1 also includes a "back" button 15 on the receiver 8, operation of which by the user can be arranged to cause the listener to be returned to the LFM.

5 The system illustrated in Figure 3 utilises a multimedia computer 80 as a receiver and an Internet connection 81 as a transport medium for passing transmitted data to and from the multimedia computer from and to audio information sources 82,83 via a server 84.

10 The system makes use of a mark-up language which is capable of catering for audio links - HAML. The current generation of mark-up languages (including HTML, HDML, TTML, etc.) although multimedia in scope are not symmetrical in the way they treat their media. They all treat text and graphical information differently to audio, in that a user can link from textual and graphical contexts into further web pages, but audio may only be listened to, ie is strictly one-way. The idea of an audio link is not catered for in these prior mark-up
15 languages.

A mark-up language for audio has special constraints within which it must work. In particular, audio is

- non-persistent - a spoken prompt will usually be replaced quickly with following material;
- 20 • time-critical - responses to prompts must be registered and acted upon quickly;
- one-dimensional - audio material is heard in time, not seen on a page.

25 Furthermore, in terms of navigation, the normal mouse driven paradigm is no longer necessarily valid. Typical terminal equipment may only have two keys for navigation - corresponding to "Follow" and "Back", and a very limited visual display. Also, the underlying transport will not necessarily be TCP/IP. The DAB MOT protocol, GSM, SMS, GPRS or circuit-switched data, and DTMF signalling over a fixed or mobile telephone link are all possible media, either
30 separately or in combination. Also, the link may not be full-duplex, especially in broadcast contexts.

In practical terms this means that features must be present in the language

- to latch link data and announce the link in a way that a listener may respond to at a later time if necessary.
- 5 • to announce to a server the form in which it should expect navigation commands.

The paucity of data link capacity also means that the traditional client-server model will be slightly modified. In fixed audio only link, it may be the case that the client runs within the network, and simply uses the link to the terminal for access to MMI events.

In the context of the system illustrated in Figure 3, the overall arrangement is substantially similar to a conventional Word Wide Web (WWW) situation, except that the client (receiver) and server use HAML rather than HTML to communicate. The actual transport mechanism may be conventional HTTP since the link between them is a conventional internet connection of medium to high bandwidth, but could be any file or stream transport protocol (eg. FTP, RealAudio etc.)

An HAML script is transferred from the server 84 to the client 80 and are executed in the client, just as HTML scripts are executed. Navigation is performed on the client machine which sends GET requests to the server (in HTTP anyway) for new content.

A simple HAML page might look like:

Example 1

```

<HAML VERSION=0.1 TIME=START_RELATIVE UNITS=MS
25 LINKSTYLE=INTERRUPT>
<PLAY SOURCE=LadyOfShallOt.wav>
<LINK_DESTINATION=http://www.ttpcom.com/tmm/camelot.haml
    ICON=castle.bmp
    START=57803
30    DURATION=5000>
<LINK DEFAULT_DESTINATION=d:\authors\tennyson.haml
    ICON=d:\authors\tennyson.bmp>
</PLAY>
</HAML>
35

```

The function of this example is to play the file "Ladyofshallot.wav" to the default output device (which is set by the interpreter of the file, not by the file itself). For most of the duration of the clip, the FORWARD button is labelled with the file d:\authors\tennyson.bmp. if the listener selects FORWARD, then interpretation jumps to the locally stored file d:\authors\tennyson.haml. For the 5s after 57.803s from the beginning of the clip, the bitmap castle .bmp is used to label the FORWARD button. If the listener presses FORWARD during that time, then the internet is used to access the file /tmm/camelot.haml on the machine www.ttpcom.com, and that file is interpreted. When interpretation of either of the linked-to files ceases, then the original clip (LadyOfShallot.wav) plays again from the point at which it the link was taken.

The keywords in order, effect a behaviour as follows:

| | | |
|----|---------------------|---|
| 15 | <HAML | introduces the file and tells the interpreter it is HAML. |
| | VERSION | version information for the interpreter. |
| | TIME=START RELATIVE | all times in the file are to be measured relative to the start of the clip. |
| | UNITS=MS | the units of time are milliseconds. |
| 20 | LINKSTYLE=INTERRUPT | if a link is taken, it interrupts the current audio. |
| | <PLAY | introduces the main audio stream. |
| | SOURCE=... | use this file as the source for the main audio stream. |
| | <LINK | introduces link information. |
| 25 | DESTINATION=... | points to an HAML file - interpretation passes to this file if FORWARD is pressed. |
| | ICON=... | display the named graphics file behind the FORWARD button. |
| 30 | START=... | the start time when the link becomes active (units and meaning defined by the TIME and UNITS parameters to the <HAML statement. |

| | | |
|----|---------------|---|
| | DURATION=... | the length of time for which the link is active (again units and meaning defined by the <HAML statement parameters). |
| 5 | <LINK DEFAULT | introduces information for the default link. This link is used when no other link is active. Note this statement has no START or DURATION parameters. |
| 10 | <IPLAY> | tells the interpreter that the information for this particular audio stream is complete. When it reaches this it can begin playing the clip defined in the <PLAY statement. |
| | </HAML> | end of page |

15 This example is suitable for a multimedia, internet-linked computer, where all the audio sources, links, icons, etc., are known beforehand.

Figure 4 illustrates a system using a convergent broadcast/telephony system employing an integrated DAB and GSM system. Again the system employs an HAML server 94 which receives audio information from sources 92,93. The receiver in this case comprises an integrated DAB/GSM terminal 20 90 which receives an initial stream of audio information form a broadcast DAB network 91 which, in turn communicates with the server 94 via an HAML/MOT gateway 95. The DAB/GSM terminal 90 communicates with a GSM cellular network 96 which also communicates with the server 94 via an HAML proxy client 97.

25 In operation, the HAML server 94 sends HAML scripts along with audio information down the DAB network link to the terminal 90. In this case, the transport protocol will preferably be the ETSI specified MOT protocol (ETS 301-234). The HAML scripts are executed in the HAML client sitting in the terminal 90. The HAML specification defines that new content is addressed by a similar 30 addressing scheme to HTML, ie a protocol specifier followed by a unique address such as:

`http://www.ttpcom.com:8080/index.html.`

In HAML the addressing scheme is very similar, for example:

`hatp://www.ttpcom.com:+441763266266/index.haml`

5 The hatp: part tells the client in the terminal 90 to invoke the Hyper Audio Transport Protocol handler (HATP) which then uses the number after the colon as a telephone number, by means of which access to the file index.haml on the machine www.ttpcom.com can be achieved. Note that the actual protocol is HATP as distinct from the language which is HAML.

10 Because the telephonic link is primarily audio (together with low bandwidth signalling like DTMF, GSM-SMS or similar), the file is not sent across the link, but rather is executed in the proxy client 97. This plays the audio information to the terminal across the telephonic link and indicates by means of a low bandwidth signal when the 'Tell Me More' button has become active and also, desirably, what text to use as a prompt on the terminals screen. The
15 terminal client 90 sends a signal to the proxy client 97 indicating key presses ('Tell Me More' or 'Back') made by the listener as they happen. The proxy client 97 can then act on the requests, by accessing the new content or returning to the old content appropriately.

20 Preferably, congestion management strategies are provided in the design of the HATP/HAML server 94 so that, if a large number of users are calling the same address, then rather than opening a full GSM voice channel to each, the listeners are returned a DAB sub-channel designator and encryption key by means of which their DAB receivers can be automatically retuned for receipt of the requested content over the DAB channel in a broadcast manner. The
25 requests can be logged for billing purposes and encryption ensures that only listeners who have paid for the content can decode it.

A further example illustrates the use of HATP/HAML:

Example 2

30 <HAML VERSION=0.1 TIME=ABSOLUTE LINKSTYLE=CONCURRENT
MIX=VOLUME>
<PLAY SOURCE=DAB>

```

<LINK PROXY
  DESTINATION=dialto:+441763262626:Camelot
  ICON=MOT CamelotIcon
  START=CamelotIcon.TriggerTime
5  END=CamelotIcon.ExpireTime>
<LINK DEFAULT DESTINATION=smsto:+441763261582:Tennyson
  ICON=MOT:TennysonIcon>
</PLAY>
</HAML>

```

10

The function of the new statements is as follows:

- TIME=ABSOLUTE all times in the file are absolute UTC.
- LINKSTYLE=CONCURRENT if a link is taken, it overlays the current audio in a style defined by the MIX parameter.
- 15 MIX=VOLUME requests that the linked-to material is mixed in with the linked-from audio stream, at a slightly higher volume to achieve separation.
- SOURCE=DAB the source of the main audio is the DAB station the listener is tuned to.
- 20 <LINK PROXY introduces a special kind of link. This says that the DESTINATION field points via a voice link to a proxy client, and that all navigation commands should therefore be sent as DTMF tones over that voice link.
- 25 DESTINATION=... In this case, the parameter value is a phone number, followed by a string. When the link is established, DTMF is used to signal the link reference (Camelot) to the server.
- ICON=... the ICON is an MOT object, with the START and END times referenced from this.
- 30 START=... the start time when the link becomes active. Note that this syntax uses the TriggerTime field of the MOT object.

DESTINATION=smssto:...

This is part of a standard link, but the sms to: prefix tells the interpreter to send a GSM short message with the designed text ("Tennyson") to the designated number.

5

CLAIMS

1. A method for transmitting audio information to a receiver, comprising:
transmitting from a first source to the receiver first audio information
5 together with other information comprising addressing data;
selectively transmitting from the receiver to a service provider a data
signal dependent on the addressing data;
matching the data signal received at the service provider with respective
further audio information; and
10 transmitting the respective further audio information from a second source
to the receiver.
2. A method according to claim 1, wherein
further addressing information is transmitted from the second source to
15 the receiver with the further audio information;
selectively transmitting to the or another service provider a further data
signal dependent on the further addressing data;
matching the data signal received at the or another service provider with
respective still further audio information; and,
20 transmitting the respective still further audio information from the second
or a further source to the receiver.
3. A method according to claim 1 or claim 2, wherein the first audio
information together with other information comprising addressing data is
25 transmitted from the first source to the receiver by a wire-less broadcast signal.
4. A method according to claim 3, wherein the broadcast signal is a digital
audio broadcasting (DAB) signal.
- 30 5. A method according to claim 3, wherein the broadcast signal is a radio
data service (RDS) signal.

6. A method according to claim 1 or claim 2, wherein the first audio information together with other information comprising addressing data is transmitted from the first source to the receiver by a cable or wire connection between the first source and the receiver.

5

7. A method according to claim 6, wherein the first audio information together with other information comprising addressing data is transmitted via an Internet connection.

10 8. A method according to any of claims 1 to 7, wherein the data signal dependent on the addressing data is transmitted from the receiver to the or another service provider by a mobile telephone connection.

15 9. A method according to claim 8, wherein the mobile telephone connection is a GSM or CDMA connection.

20 10. A method according to any of claims 1 to 7, wherein the data signal dependent on the addressing data is transmitted from the receiver to the or another service provider by a cable or wire connection between the receiver and the or another service provider.

25 11. A method according to any of claims 1 to 7, wherein the data signal dependent on the addressing data is transmitted from the receiver to the or another service provider by an Internet connection between the receiver and the or another service provider.

30 12. A method according to any of claims 1 to 11, wherein the data signal received at the or another service provider is matched with the respective second audio information utilising a database of audio information.

13. A method according to any of claims 1 to 12, wherein the respective further audio information is transmitted from the second or further source to the receiver by a mobile telephone connection.

5 14. A method according to claim 13, wherein the respective further audio information is transmitted from the second or further source to the receiver by a GSM or CDMA connection.

10 15. A method according to any of claims 1 to 11, wherein the respective further audio information is transmitted from the second or further source to the receiver by a cable or wire connection between the second or further source and the receiver.

15 16. A method according to any of claims 1 to 11, wherein the respective further audio information is transmitted from the second or further source to the receiver by an Internet connection between the second or further source and the receiver.

20 17. A system for transmitting audio information to a receiver, comprising:
a first source for transmitting to the receiver first audio information together with other information comprising addressing data;
means at the receiver for converting the first audio information to an audio signal;
means at the receiver selectively operable for transmitting to a service
25 provider a data signal dependent on the addressing data;
comparing means for matching the data signal received at the service provider with respective further audio information;
a second source for transmitting the respective further audio information from the service provider to the receiver; and,
30 means at the receiver for converting the further audio information to an audio signal.

18. A system according to claim 17, wherein further addressing information is transmitted from the second source to the receiver with the further audio information;

5 the receiver having means selectively operable to transmit to the or another service provider a further data signal dependent on the further addressing data;

comparing means for matching the further data signal received at the or another service provider with respective still further audio information; and,

10 means at the second or a further source for transmitting the respective still further audio information to the receiver.

19. A system according to claim 17 or claim 18, wherein the first audio information together with other information comprising addressing data is transmitted from the first source to the receiver by a wire-less broadcast signal.

15

20. A system according to claim 19, wherein the broadcast signal is a digital audio broadcasting (DAB) signal.

21. A system according to claim 19, wherein the broadcast signal is a radio data service (RDS) signal.

20

22. A system according to claim 17 or claim 18, wherein the first audio information together with other information comprising addressing data is transmitted from the first source to the receiver by a cable or wire connection between the first source and the receiver.

25

23. A system according to claim 22, wherein the first audio information together with other information comprising addressing data is transmitted via an Internet connection.

30

24. A system according to any of claims 17 to 23, wherein the receiver includes a mobile telephone and the data signal dependent on the addressing data is transmitted from the receiver to the or another service provider by a mobile telephone connection.

5

25. A system according to claim 24, wherein the mobile telephone is a GSM or CDMA telephone.

10

26. A system according to any of claims 17 to 23, wherein the data signal dependent on the addressing data is transmitted from the receiver to the or another service provider by a cable or wire connection between the receiver and the or another service provider respectively.

15

27. A system according to claim 26, wherein the receiver includes a wire or cable-connected telephone.

20

28. A system according to any of claims 17 to 23, wherein the data signal dependent on the addressing data is transmitted from the receiver to the or another service provider by an Internet connection between the receiver and the or another service provider.

25

29. A system according to any of claims 17 to 28, further comprising a database of audio information connected to the second or further source, whereby the data signal received at the or another service provider is matched with the respective further audio information respectively.

30

30. A system according to claim 24 or claim 25, wherein the respective further audio information is transmitted from the second or further source to the receiver by a mobile telephone connection.

31. A system according to claim 26 or claim 27, wherein the respective further audio information is transmitted from the second or further source respectively to the receiver by the cable or wire connection between the second or further source respectively and the receiver.

5

32. A system according to claim 28, wherein the respective further audio information is transmitted from the second or further source to the receiver by an Internet connection between the second or further source and the receiver.

10 33. A system according to any of claims 17 to 32, wherein the receiver comprises a key operable to initiate the transmission of the respective data signal dependent on the addressing data to the or another service provider respectively.

15 34. A system according to claim 33, wherein the receiver comprises a further key operable to cancel the receipt of the respective further audio information from the second or further source respectively at the receiver and to cause the receiver to convert the audio information from the first or second source respectively to an audio signal.

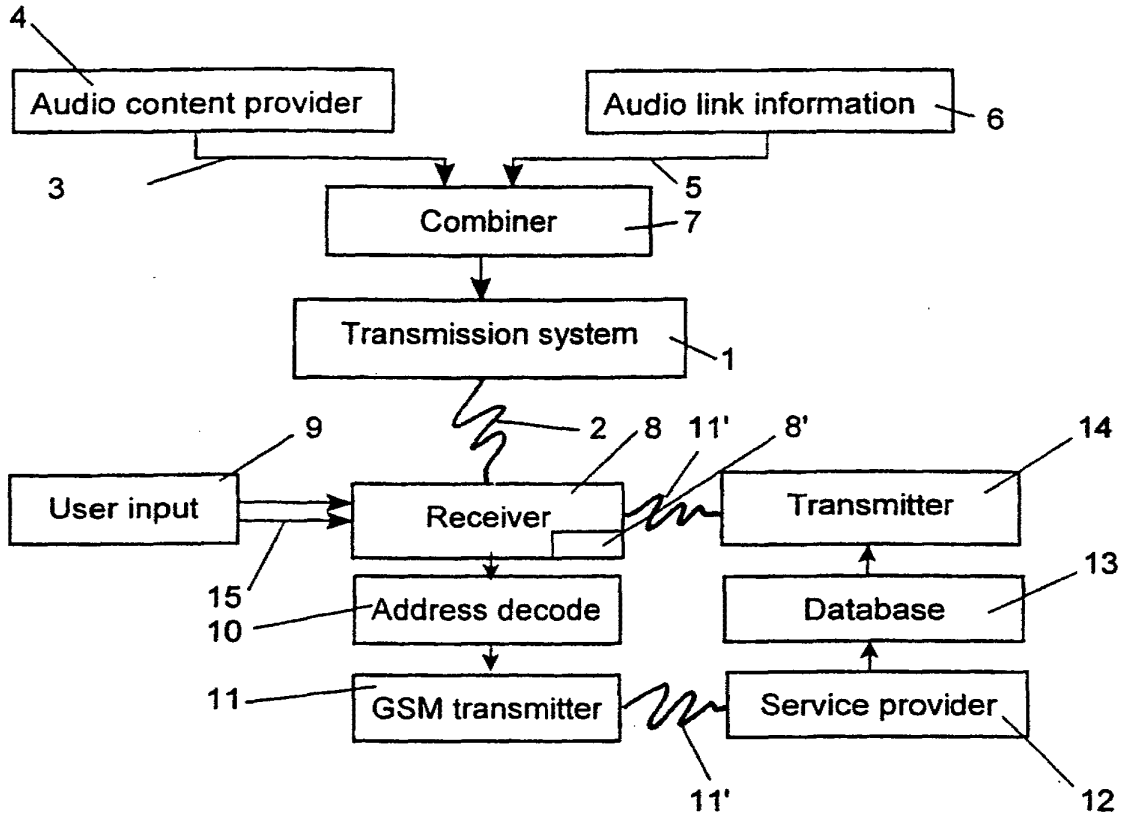

Figure 1

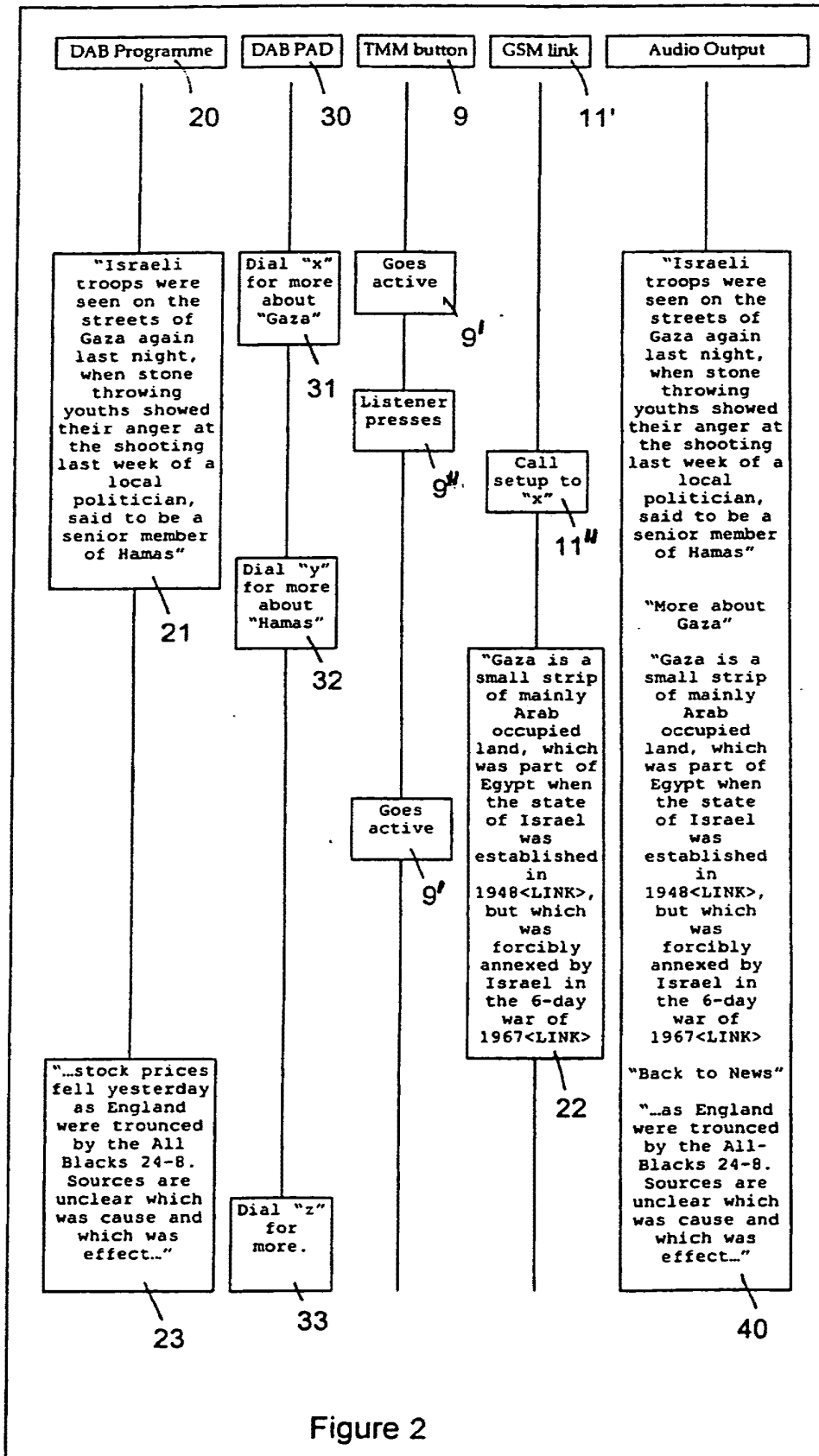

Figure 2

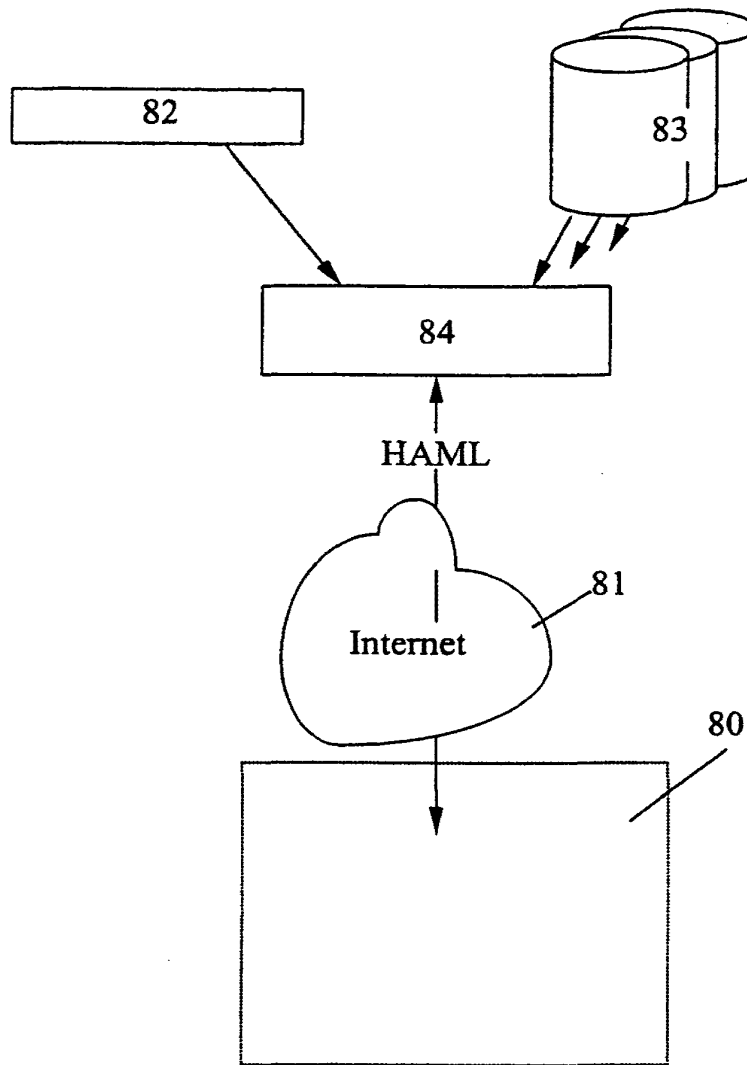

Figure 3

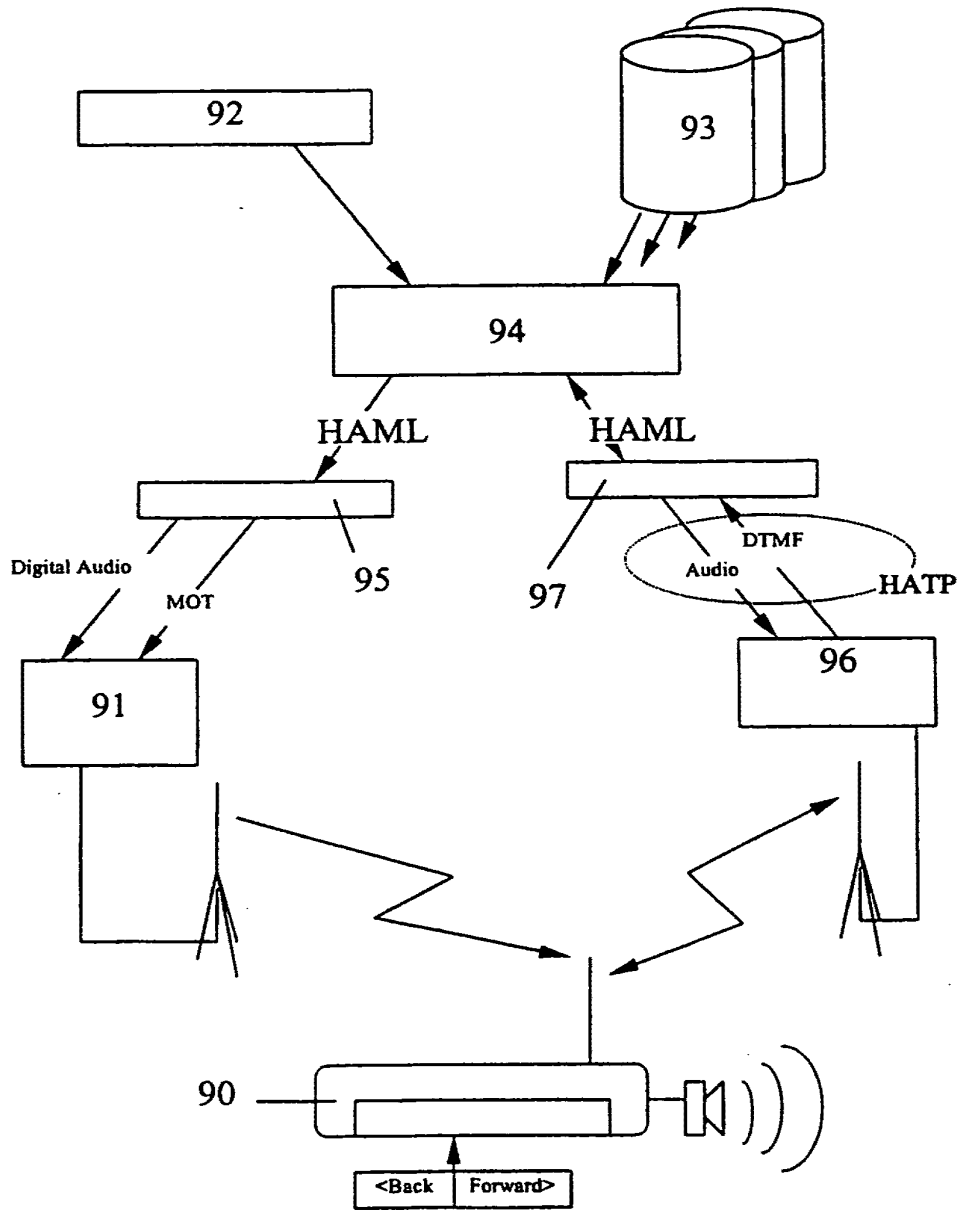

Figure 4

INTERNATIONAL SEARCH REPORT

International Application No

PCT/GB 99/00514

A. CLASSIFICATION OF SUBJECT MATTER
IPC 6 H04H1/00

According to International Patent Classification (IPC) or to both national classification and IPC

B. FIELDS SEARCHED

Minimum documentation searched (classification system followed by classification symbols)

IPC 6 H04H

Documentation searched other than minimum documentation to the extent that such documents are included in the fields searched

Electronic data base consulted during the international search (name of data base and, where practical, search terms used)

C. DOCUMENTS CONSIDERED TO BE RELEVANT

| Category * | Citation of document, with indication, where appropriate, of the relevant passages | Relevant to claim No. |
|------------|---|---------------------------|
| A | GB 2 313 981 A (ROKE MANOR RESEARCH) 10 December 1997 see page 1, line 1 - page 6, line 13; claims 1,10; figure 1 --- | 1,4,9, 13,17, 20,25 |
| A | EP 0 804 012 A (NOKIA MOBILE PHONES LTD) 29 October 1997 see column 1, line 1 - column 9, line 25; claim 1 --- | 1,4,9, 13,17, 20,25 |
| A | WO 95 12929 A (NSM AG ;FRANK ARMIN (DE)) 11 May 1995 see page 3, line 12 - page 6, line 2; claims 1,4,11,12; figure 1 --- -/-- | 1,17 |

Further documents are listed in the continuation of box C.

Patent family members are listed in annex.

* Special categories of cited documents :

- "A" document defining the general state of the art which is not considered to be of particular relevance
- "E" earlier document but published on or after the international filing date
- "L" document which may throw doubts on priority claim(s) or which is cited to establish the publication date of another citation or other special reason (as specified)
- "O" document referring to an oral disclosure, use, exhibition or other means
- "P" document published prior to the international filing date but later than the priority date claimed

- "T" later document published after the international filing date or priority date and not in conflict with the application but cited to understand the principle or theory underlying the invention
- "X" document of particular relevance; the claimed invention cannot be considered novel or cannot be considered to involve an inventive step when the document is taken alone
- "Y" document of particular relevance; the claimed invention cannot be considered to involve an inventive step when the document is combined with one or more other such documents, such combination being obvious to a person skilled in the art.
- "&" document member of the same patent family

Date of the actual completion of the international search

29 April 1999

Date of mailing of the international search report

04/06/1999

Name and mailing address of the ISA

European Patent Office, P.B. 5818 Patentlaan 2
 NL - 2280 HV Rijswijk
 Tel. (+31-70) 340-2040, Tx. 31 651 epo nl.
 Fax: (+31-70) 340-3016

Authorized officer

De Haan, A. J.

INTERNATIONAL SEARCH REPORT

International Application No

PCT/GB 99/00514

C.(Continuation) DOCUMENTS CONSIDERED TO BE RELEVANT

| Category | Citation of document, with indication, where appropriate, of the relevant passages | Relevant to claim No. |
|----------|---|-----------------------|
| A | EP 0 084 778 A (DISCOVISION ASS) 3 August 1983 see page 8, line 1 - page 9, line 25; claim 1; figure 1 ----- | 1,17 |
| A | WO 93 09631 A (FINISAR CORP) 13 May 1993 see page 1, line 1 - page 5, line 7; claims 1,13; figures 1,2 ----- | 1,17 |
| A | EP 0 817 139 A (SUN MICROSYSTEMS INC) 7 January 1998 see column 1, line 1 - column 2, line 47; claim 1; figures 1,5 ----- | 1,17 |

INTERNATIONAL SEARCH REPORT

Information on patent family members

International Application No

PCT/GB 99/00514

| Patent document cited in search report | | Publication date | Patent family member(s) | Publication date |
|--|---|------------------|---|--|
| GB 2313981 | A | 10-12-1997 | NONE | |
| EP 0804012 | A | 29-10-1997 | FI 961750 A JP 10098706 A | 24-10-1997 14-04-1998 |
| WO 9512929 | A | 11-05-1995 | DE 4337726 A EP 0727114 A US 5742893 A | 11-05-1995 21-08-1996 21-04-1998 |
| EP 0084778 | A | 03-08-1983 | AT 59514 T HK 34692 A JP 2027904 C JP 7043882 B JP 58133087 A JP 2726394 B JP 7262702 A JP 2501521 B JP 7134866 A JP 2597083 B JP 8255463 A US 4757393 A | 15-01-1991 22-05-1992 19-03-1996 15-05-1995 08-08-1983 11-03-1998 13-10-1995 29-05-1996 23-05-1995 02-04-1997 01-10-1996 12-07-1988 |
| WO 9309631 | A | 13-05-1993 | US 5404505 A AU 654885 B AU 2909092 A CA 2121592 A EP 0610367 A | 04-04-1995 24-11-1994 07-06-1993 13-05-1993 17-08-1994 |
| EP 0817139 | A | 07-01-1998 | JP 10232690 A | 02-09-1998 |



UNITED STATES PATENT AND TRADEMARK OFFICE

UNITED STATES DEPARTMENT OF COMMERCE
United States Patent and Trademark Office
Address: COMMISSIONER FOR PATENTS
P.O. Box 1450
Alexandria, Virginia 22313-1450
www.uspto.gov

| APPLICATION NO. | FILING DATE | FIRST NAMED INVENTOR | ATTORNEY DOCKET NO. | CONFIRMATION NO. |
|-----------------|-------------|----------------------|---------------------|------------------|
| 09/953,335 | 09/13/2001 | Kelly M. Christensen | STRATOS.001A | 4917 |

20995 7590 06/27/2003

KNOBBE MARTENS OLSON & BEAR LLP
2040 MAIN STREET
FOURTEENTH FLOOR
IRVINE, CA 92614

EXAMINER

KRAMER, JAMES A

| ART UNIT | PAPER NUMBER |
|----------|--------------|
| 3627 | |

DATE MAILED: 06/27/2003

Please find below and/or attached an Office communication concerning this application or proceeding.

JK

| | | | |
|------------------------------|--------------------------------------|---|--|
| Office Action Summary | Application No. 09/953,335 | Applicant(s) CHRISTENSEN ET AL. | |
| | Examiner James A. Kramer | Art Unit 3627 | |

-- The MAILING DATE of this communication appears on the cover sheet with the correspondence address --

Period for Reply

A SHORTENED STATUTORY PERIOD FOR REPLY IS SET TO EXPIRE 3 MONTH(S) FROM THE MAILING DATE OF THIS COMMUNICATION.

- Extensions of time may be available under the provisions of 37 CFR 1.136(a). In no event, however, may a reply be timely filed after SIX (6) MONTHS from the mailing date of this communication.
- If the period for reply specified above is less than thirty (30) days, a reply within the statutory minimum of thirty (30) days will be considered timely.
- If NO period for reply is specified above, the maximum statutory period will apply and will expire SIX (6) MONTHS from the mailing date of this communication.
- Failure to reply within the set or extended period for reply will, by statute, cause the application to become ABANDONED (35 U.S.C. § 133).
- Any reply received by the Office later than three months after the mailing date of this communication, even if timely filed, may reduce any earned patent term adjustment. See 37 CFR 1.704(b).

Status

- 1) Responsive to communication(s) filed on _____ .
- 2a) This action is **FINAL**. 2b) This action is non-final.
- 3) Since this application is in condition for allowance except for formal matters, prosecution as to the merits is closed in accordance with the practice under *Ex parte Quayle*, 1935 C.D. 11, 453 O.G. 213.

Disposition of Claims

- 4) Claim(s) 1-26 is/are pending in the application.
4a) Of the above claim(s) 16-18 is/are withdrawn from consideration.
- 5) Claim(s) _____ is/are allowed.
- 6) Claim(s) 1-15 and 19-26 is/are rejected.
- 7) Claim(s) _____ is/are objected to.
- 8) Claim(s) _____ are subject to restriction and/or election requirement.

Application Papers

- 9) The specification is objected to by the Examiner.
- 10) The drawing(s) filed on _____ is/are: a) accepted or b) objected to by the Examiner.
Applicant may not request that any objection to the drawing(s) be held in abeyance. See 37 CFR 1.85(a).
- 11) The proposed drawing correction filed on _____ is: a) approved b) disapproved by the Examiner.
If approved, corrected drawings are required in reply to this Office action.
- 12) The oath or declaration is objected to by the Examiner.

Priority under 35 U.S.C. §§ 119 and 120

- 13) Acknowledgment is made of a claim for foreign priority under 35 U.S.C. § 119(a)-(d) or (f).
a) All b) Some * c) None of:
1. Certified copies of the priority documents have been received.
2. Certified copies of the priority documents have been received in Application No. _____ .
3. Copies of the certified copies of the priority documents have been received in this National Stage application from the International Bureau (PCT Rule 17.2(a)).
* See the attached detailed Office action for a list of the certified copies not received.
- 14) Acknowledgment is made of a claim for domestic priority under 35 U.S.C. § 119(e) (to a provisional application).
a) The translation of the foreign language provisional application has been received.
- 15) Acknowledgment is made of a claim for domestic priority under 35 U.S.C. §§ 120 and/or 121.

Attachment(s)

- 1) Notice of References Cited (PTO-892) 4) Interview Summary (PTO-413) Paper No(s). _____ .
- 2) Notice of Draftsperson's Patent Drawing Review (PTO-948) 5) Notice of Informal Patent Application (PTO-152)
- 3) Information Disclosure Statement(s) (PTO-1449) Paper No(s) 4 & 6 . 6) Other:

Art Unit: 3627

DETAILED ACTION

Restriction

Restriction to one of the following inventions is required under 35 U.S.C. 121:

- I. Claims 1-15 and 19-26, drawn to an order placement system and method.
- II. Claims 16-18, drawn to an order fulfillment system.

The inventions are distinct, each from the other because of the following reasons:

Inventions I and II are related as subcombinations disclosed as usable together in a single combination. The subcombinations are distinct from each other if they are shown to be separately usable. In the instant case, invention II has separate utility such as being used to fulfill an order received from a materially different placement system. See MPEP § 806.05(d).

Because these inventions are distinct for the reasons given above and the search required for Group I is not required for Group II, restriction for examination purposes as indicated is proper.

During a telephone conversation on 6/6/03 with Perry Oldham a provisional election was made without traverse to prosecute the invention of I, claims 1-15 and 19-26. Affirmation of this election must be made by applicant in replying to this Office action. Claims 16-18 are withdrawn from further consideration by the examiner, 37 CFR 1.142(b), as being drawn to a non-elected invention.

Applicant is reminded that upon the cancellation of claims to a non-elected invention, the inventorship must be amended in compliance with 37 CFR 1.48(b) if one or more of the currently named inventors is no longer an inventor of at least one claim remaining in the

Art Unit: 3627

application. Any amendment of inventorship must be accompanied by a request under 37 CFR 1.48(b) and by the fee required under 37 CFR 1.17(i).

Claim Rejections - 35 USC § 103

The following is a quotation of 35 U.S.C. 103(a) which forms the basis for all obviousness rejections set forth in this Office action:

(a) A patent may not be obtained though the invention is not identically disclosed or described as set forth in section 102 of this title, if the differences between the subject matter sought to be patented and the prior art are such that the subject matter as a whole would have been obvious at the time the invention was made to a person having ordinary skill in the art to which said subject matter pertains. Patentability shall not be negated by the manner in which the invention was made.

Claims 1-15 & 19-26 are rejected under 35 U.S.C. 103(a) as being unpatentable over Noreen et al.

Noreen et al. teaches an integrated radio satellite response system and method. In particular the system includes a mobile terminal with receiver means for receiving a program signal from broadcast channel (column 2; lines 41-44). The mobile terminal also contains a controller means for processing identification information provided on a subchannel of the program signal (column 2; lines 54-64). The mobile terminal also includes an interface means, which communicates the program signal to the user and allows the user to respond to the program signal creating a user-input signal (column 2; lines 45-53). The mobile unit of Noreen et al. further includes a data-transmitter means for transmitting the user-input signal for processing (column 2; lines 65-68). Finally the mobile unit of Noreen et al. includes a digital interface as a peripheral device (column 6; lines 28-34).

The system of Noreen et al. does not teach the data-transmitter means specifically being a serial port or parallel port. Examiner notes that it is old and well known in the art to use parallel

Art Unit: 3627

port and serial ports for connecting terminal to networks in order to transmit data. Therefore It would have been obvious to a person of ordinary skill in the art at the time the invention was made to use either a parallel port or serial port as the data-transmitter means of Noreen et al. in order to connect the system to a network (i.e. the Internet) and transmit the data.

The system of Noreen et al. does not teach a media down load device attached to the mobile unit. Examiner notes that media down load devices are old and well known in the art in order to receive purchased digital content in a mobile environment. Therefore It would have been obvious to a person of ordinary skill in the art at the time the invention was made to include a media down load device to the digital interface of the mobile unit of Noreen et al. in order to receive digital content.

The system on Noreen et al. does not specifically mention extracting a RBDS data signal from a broadcast channel. Examiner notes that a RBDC data signal is an old and well-known subchannel of a standard radio broadcast and is often used as it is an extensive and widely known standard. Examiner references Applicant's disclosure on page 1; line 26 to support this assertion. Therefore, it would be a design choice for the controller means of Noreen et al. to extract a RBDS data signal in order to utilize and extensive and widely known standard.

Conclusion

Any inquiry concerning this communication or earlier communications from the examiner should be directed to James A. Kramer whose telephone number is (703) 305-5241. The examiner can normally be reached on Monday - Friday (8AM - 5PM).

Art Unit: 3627

If attempts to reach the examiner by telephone are unsuccessful, the examiner's supervisor, Richard Chilcot can be reached on (703) 305-4716. The fax phone numbers for the organization where this application or proceeding is assigned are (703) 308-3687 for regular communications and (703) 872-9327 for After Final communications.

Any inquiry of a general nature or relating to the status of this application or proceeding should be directed to the receptionist whose telephone number is (703) 308-1113.

James A. Kramer
Examiner
Art Unit 3627

JAK
June 20, 2003

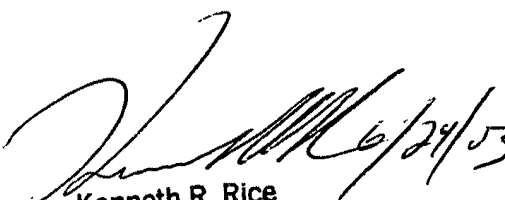
Kenneth R. Rice
Primary Examiner

| | | | |
|-----------------------------------|---------------------------------------|--|-------------|
| Notice of References Cited | Application/Control No. 09/953,335 | Applicant(s)/Patent Under Reexamination CHRISTENSEN ET AL. | |
| | Examiner James A. Kramer | Art Unit 3627 | Page 1 of 1 |

U.S. PATENT DOCUMENTS

| * | Document Number Country Code-Number-Kind Code | Date MM-YYYY | Name | Classification |
|---|--|-----------------|---------------|----------------|
| A | US-5,303,393 | 04-1994 | Noreen et al. | 455/3.02 |
| B | US- | | | |
| C | US- | | | |
| D | US- | | | |
| E | US- | | | |
| F | US- | | | |
| G | US- | | | |
| H | US- | | | |
| I | US- | | | |
| J | US- | | | |
| K | US- | | | |
| L | US- | | | |
| M | US- | | | |

FOREIGN PATENT DOCUMENTS

| * | Document Number Country Code-Number-Kind Code | Date MM-YYYY | Country | Name | Classification |
|---|--|-----------------|---------|------|----------------|
| N | | | | | |
| O | | | | | |
| P | | | | | |
| Q | | | | | |
| R | | | | | |
| S | | | | | |
| T | | | | | |

NON-PATENT DOCUMENTS

| * | Include as applicable: Author, Title Date, Publisher, Edition or Volume, Pertinent Pages) |
|---|---|
| U | |
| V | |
| W | |
| X | |

*A copy of this reference is not being furnished with this Office action. (See MPEP § 707.05(a).)
 Dates in MM-YYYY format are publication dates. Classifications may be US or foreign.

| | | | |
|---|--|-----------------------------------|-------------------------------|
| FORM PTO-1449 | U.S. DEPARTMENT OF COMMERCE PATENT AND TRADEMARK OFFICE | ATTY. DOCKET NO. STRATOS.001A | APPLICATION NO. 09/953,335 |
| INFORMATION DISCLOSURE STATEMENT BY APPLICANT (USE SEVERAL SHEETS IF NECESSARY) | | APPLICANT Christensen, et al. | |
| | | FILING DATE September 13, 2001 | GROUP 2681 |

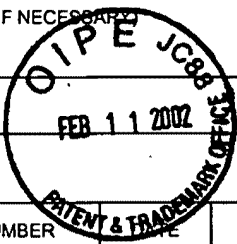

RECEIVED
FEB 15 2002
Technology Center 2600

U.S. PATENT DOCUMENTS

| EXAMINER INITIAL | DOCUMENT NUMBER | DATE | NAME | CLASS | SUBCLASS | FILING DATE (IF APPROPRIATE) |
|------------------|-----------------|----------|-------------------|-------|----------|------------------------------|
| JAK | 5,539,635 | 07/23/96 | Larson, Jr. | | | |
| JAK | 5,557,541 | 09/17/96 | Schulhof, et al. | | | |
| JAK | 5,579,537 | 11/26/96 | Takahisa | | | |
| JAK | 5,661,787 | 08/26/97 | Pocock | | | |
| JAK | 5,708,478 | 01/13/98 | Tognazzini | | | |
| JAK | 5,857,156 | 01/05/99 | Anderson | | | |
| JAK | 5,905,865 | 05/18/99 | Palmer, et al. | | | |
| JAK | 5,991,601 | 11/23/99 | Anderson | | | |
| JAK | 5,991,737 | 11/23/99 | Chen | | | |
| JAK | 6,036,086 | 03/14/00 | Sizer, II, et al. | | | |
| JAK | 6,098,106 | 08/01/00 | Philyaw, et al. | | | |

FOREIGN PATENT DOCUMENTS

| EXAMINER INITIAL | DOCUMENT NUMBER | DATE | COUNTRY | CLASS | SUBCLASS | TRANSLATION | |
|------------------|-----------------|----------|---------|-------|----------|-------------|----|
| | | | | | | YES | NO |
| JAK | 2000292182 A | 10/20/00 | JAPAN | | | | |
| | | | | | | | |
| | | | | | | | |
| | | | | | | | |

OTHER DOCUMENTS (INCLUDING AUTHOR, TITLE, DATE, PERTINENT PAGES, ETC.)

| | |
|------------------|--|
| EXAMINER INITIAL | |
| | |
| | |
| | |

H:\DOCS\WHLWH-6582.DOC:jk
020702

| | |
|--|--------------------------------|
| EXAMINER <i>Jano Khan</i> | DATE CONSIDERED <i>5/28/03</i> |
| *EXAMINER: INITIAL IF CITATION CONSIDERED, WHETHER OR NOT CITATION IS IN CONFORMANCE WITH MPEP 609; DRAW LINE THROUGH CITATION IF NOT IN CONFORMANCE AND NOT CONSIDERED, INCLUDE COPY OF THIS FORM WITH NEXT COMMUNICATION TO APPLICANT. | |

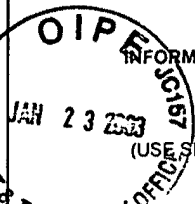
| | | | |
|---|--|-----------------------------------|-------------------------------|
| FORM PTO-1449 | U.S. DEPARTMENT OF COMMERCE PATENT AND TRADEMARK OFFICE | ATTY. DOCKET NO. STRATOS.001A | APPLICATION NO. 09/953,335 |
|  <p>INFORMATION DISCLOSURE STATEMENT BY APPLICANT (USE SEVERAL SHEETS IF NECESSARY)</p> | | APPLICANT Christensen et al | |
| | | FILING DATE September 13, 2001 | GROUP Unknown |

U.S. PATENT DOCUMENTS

| EXAMINER INITIAL | DOCUMENT NUMBER | DATE | NAME | CLASS | SUBCLASS | FILING DATE (IF APPROPRIATE) |
|------------------|-----------------|-----------|---------|-------|----------|------------------------------|
| JAK | 1 | 5,907,793 | 5/25/99 | Reams | | |
| | | | | | | |
| | | | | | | |
| | | | | | | |
| | | | | | | |
| | | | | | | |
| | | | | | | |
| | | | | | | |
| | | | | | | |
| | | | | | | |
| | | | | | | |
| | | | | | | |

RECEIVED
JAN 27 2003
GROUP 3600

FOREIGN PATENT DOCUMENTS

| EXAMINER INITIAL | DOCUMENT NUMBER | DATE | COUNTRY | CLASS | SUBCLASS | TRANSLATION | |
|------------------|-----------------|----------------|---------|-------------------|----------|-------------|----|
| | | | | | | YES | NO |
| JAK | 2 | PCT/CH99/00006 | 7/15/99 | Switzerland/PCT | | | |
| JAK | 3 | PCT/GB99/00514 | 8/26/99 | Great Britain/PCT | | | |
| | | | | | | | |
| | | | | | | | |
| | | | | | | | |

| EXAMINER INITIAL | OTHER DOCUMENTS (INCLUDING AUTHOR, TITLE, DATE, PERTINENT PAGES, ETC.) |
|------------------|--|
| | |
| | |
| | |
| | |

H:\DOCS\IPDO\IPDO-1934.DOC
011303

| | |
|-------------------------------|--------------------------------|
| EXAMINER <i>James J. Kram</i> | DATE CONSIDERED <i>5/28/03</i> |
|-------------------------------|--------------------------------|

*EXAMINER INITIAL IF CITATION CONSIDERED, WHETHER OR NOT CITATION IS IN CONFORMANCE WITH MPEP 609; DRAW LINE THROUGH CITATION IF NOT IN CONFORMANCE AND NOT CONSIDERED, INCLUDE COPY OF THIS FORM WITH NEXT COMMUNICATION TO APPLICANT.

NOV 25 2003

Knobbe Martens Olson & Bear LLP
Intellectual Property Law

OFFICIAL

2040 Main Street
Fourteenth Floor
Irvine, CA 92614
Tel 949-760-0404
Fax 949-760-9502
www.kmob.com

FACSIMILE TRANSMITTAL SHEET

CONFIRMATION COPY WILL FOLLOW VIA:

- MAIL
- INTERNATIONAL AIRMAIL
- COURIER
- E-MAIL
- WILL NOT FOLLOW
- HAND DELIVERY
- WITH ENCLOSURES
- WITHOUT ENCLOSURES

Confidentiality Notice:

The documents accompanying this facsimile transmission contain confidential information which may be legally privileged. The information is intended only for the use of the recipient named below. If you have received this facsimile in error, please immediately notify us by telephone to arrange for return of the original documents to us; and any disclosure, copying, distribution or the taking of any action in reliance on the contents of this faxed information is strictly prohibited.

To: **U.S. PATENT & TRADEMARK OFFICE**
 FACSIMILE NO.: (703) 872-9306
 OUR REF.: STRATOS.001A
 APP. NO.: 09/953,335
 FILING DATE: September 13, 2001
 FROM: Perry D. Oldham
 OPERATOR: Perry D. Oldham
 DATE: November 25, 2003

NO. OF PAGES: 17 (incl. cover sheet)
 TIME:

IF YOU DID NOT RECEIVE ALL OF THE PAGES PLEASE CALL BACK IMMEDIATELY

OPERATOR PHONE NO.: (949) 760-0404 FACSIMILE NO.: (949) 760-9502

MESSAGE: OFFICE ACTION RESPONSE

PERRY D. OLDHAM
(949) 721-2961

H:\DOCS\PD\O\FAXES\PTO FAX.DOC
112503

San Diego
619-235-8550

San Francisco
415-954-4114

Los Angeles
310-551-3450

Riverside
909-781-9231

San Luis Obispo
805-547-5580

PATENT

Case Docket No. STRATOS.001A

Date: November 25, 2003

Page 1

In re application of : Kelly Christensen et al
 App. No. : 09/953,335
 Filed : September 13, 2001
 For : SYSTEM AND METHOD FOR ORDERING AND DELIVERING MEDIA CONTENT
 Examiner : James Kramer
 Art Unit : 3627

CERTIFICATE OF FAX TRANSMISSION

I hereby certify that this correspondence and all marked attachments are being transmitted via facsimile to Examiner James Kramer, Fax No. (703) 308-3687 of the USPTO on the date shown below:

November 25, 2003

(Date)

Perry J. Oldham

Perry J. Oldham, Reg. No. 52,082

COMMISSIONER FOR PATENTS
 P.O. Box 1450
 Alexandria, VA 22313-1450

Sir:

Transmitted herewith is an amendment in the above-identified application.

(X) An extension of time to respond for 2 month(s) is hereby requested.

Time Extension Fee:

- one month (\$55 small entity)
- two months (\$210 small entity)
- three months (\$475 small entity)

The fee has been calculated as shown below:

| CLAIMS AS FILED | | | | | | |
|--|----------------------------------|---|---------------------------------|---------------|------|----------------|
| | CLAIMS REMAINING AFTER AMENDMENT | | HIGHEST NO. PREVIOUSLY PAID FOR | PRESENT EXTRA | RATE | ADDITIONAL FEE |
| Total Claims | 23 | — | 26 | = 23 × | \$9 | = \$0 |
| Independent Claims | 7 | — | 8 | = 0 × | \$43 | = \$0 |
| Time Extension Fee | | | | | | \$210 |
| TOTAL ADDITIONAL FEE FOR THIS AMENDMENT | | | | | | \$210 |

PATENT

Case Docket No. STRATOS.001A

Date: November 25, 2003

Page 2

-
- (X) The present application qualifies for small entity status under 37 C.F.R. § 1.27.
 - (X) Information Disclosure Statement (13 References to be mailed under separate cover)
 - (X) Return prepaid postcard.
 - (X) Please charge our Deposit Account in the amount of \$210.
 - (X) Please charge any additional fees, including any fees for additional extension of time, or credit overpayment to Deposit Account No. 11-1410.

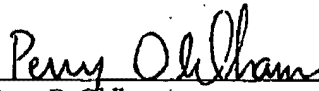

Perry D. Oldham
Registration No. 52,082
Attorney of Record
Customer No. 20,995
(949) 760-0404

H:\DOCS\PDO\PIDO-2225.DOC
112503

RECEIVED
CENTRAL FAX CENTER

004

NOV 25 2003

OFFICIAL

PATENT

11/25/03
S/A
Ext/...

STRATOS.001A

IN THE UNITED STATES PATENT AND TRADEMARK OFFICE

| | | |
|----------------|---|---|
| Applicant | : | Christensen et al. |
| Appl. No. | : | 09/953,335 |
| Filed | : | September 13, 2001 |
| For | : | SYSTEM AND METHOD FOR ORDERING AND DELIVERING MEDIA CONTENT |
| Examiner | : | James Kramer |
| Group Art Unit | : | 3627 |

CERTIFICATE OF FAX TRANSMISSION

I hereby certify that this correspondence and all marked attachments are being transmitted via facsimile to Examiner James A. Kramer, Fax No. (703) 308-3687 of the USPTO on the date shown below:

November 25, 2003

(Date)

Perry D. Oldham
Perry D. Oldham, Reg. No. 52,082

RESPONSE TO OFFICE ACTION

Commissioner for Patents
P.O. Box 1450
Alexandria, VA 22313-1450

Dear Sir:

In response to a June 27, 2003 Office Action, Applicants respond as follows:

Amendments to the Specification begin on page 2 of this paper.

Amendments to the Claims are reflected in the listing of claims which begins on page 3 of this paper.

Remarks/Arguments begin on page 10 of this paper.

11/28/2003 SCALLIHA 00000003 111410 09953335

01 FC:1252 420.00 DA

Appl. No. : 09/953,335
Filed : September 13, 2001

AMENDMENTS TO THE SPECIFICATION

Please replace the paragraph beginning at page 3, line 1 with the following amended paragraph:

A1

A similar standard used in Europe is the European Radio Data Service System (RDS).

Please replace the paragraph beginning at page 6, line 29 with the following amended paragraph:

A2

In one embodiment, a pointer to an ~~Open Application Data (OAD)~~ Open Data Applications (ODA) group is transmitted in a Type 3A group. The pointer, 16 message bits and 16 bit identifier (AID) are transmitted once a second.

Please replace the paragraph beginning at page 7, line 1 with the following amended paragraph:

A3

In one embodiment, an ~~[[OAD]]~~ ODA group with 37 usable bits is transmitted once a second during the broadcast of a "tagged" program. The ~~[[OAD]]~~ ODA group can contain, for example, a song or commercial campaign identification.

Appl. No. : 09/953,335
Filed : September 13, 2001

AMENDMENTS TO THE CLAIMS

Claim 1 (currently amended): ~~A system for performing a transaction based on data provided as part of that allows a user to perform an action responsive to program material contained in a broadcast signal, comprising:~~

a program material identification tagging system that obtains digital identifying information about the program material from a broadcaster and provides a unique program reference tag corresponding to the identifying information to a broadcast data encoder for broadcast and to a program history database;

a broadcast receiver circuit that extracts a RBDS broadcast data signal from a broadcast channel, said the broadcast channel comprising an audio stream and a RBDS broadcast data stream, wherein the data stream comprises the unique program reference tag that corresponds to the identifying information about the that identifies program material in the audio stream;

a display capable of displaying information corresponding to the data signal;

a user input control that allows a user to select a transaction make a selection from the displayed information; and

a first output module that provides an output signal comprising the selected program reference tag and a user reference tag, the output signal being provided to the program reference tag history database;

a first comparator that compares the user reference tag with stored user information and generates an approval signal;

a second comparator that compares the selected program reference tag with the unique program reference tag provided by the program reference tag history database and generates a verification signal; and

a second output module that generates a fulfillment signal based upon the approval signal and the verification signal.

~~an output device that provides a transaction request comprising an identity of a user and an identification of the selected transaction, said transaction request being provided to a response authentication system.~~

A

Appl. No. : 09/953,335
Filed : September 13, 2001

Claim 2 (original): The system as in Claim 1, wherein the displayed information identifies a media file available for purchase.

Claim 3 (currently amended): The system as in Claim 2, further comprising an input to receive the media file. ~~purchase audio.~~

Claim 4 (original): The system as in Claim 3, wherein the input is a wireless network connection.

Claim 5 (currently amended): The system as in Claim 1, wherein the first output device is module comprises a removable memory device.

Claim 6 (currently amended): The system as in Claim 1, wherein the first output device is module comprises a serial data port.

Claim 7 (currently amended): The system as in Claim 1, wherein the first output device is module comprises a parallel data port.

Claim 8 (currently amended): The system as in Claim 1, wherein the first output device is module comprises a wireless transmitter.

Claim 9 (currently amended): A system for responding to a data stream sent in combination with a media stream on a radio broadcast signal, comprising:

a broadcast receiver circuit that detects the radio broadcast signal and extracts a data signal from the data stream, at least a portion of the data signal configured to identify program content in said media stream;

memory for storing the data signal;

a display for displaying information corresponding to the data signal;

a user input control that allows a user to initiate a purchase request corresponding to the data signal;

~~a transmitter that transmits the purchase request to a response authentication system;~~

a first output module that provides an output signal comprising the identified program content and a user reference tag, the output signal being provided to a program reference tag history database;

a first comparator that compares the user reference tag with stored user information and generates an approval signal;

Appl. No. : 09/953,335
Filed : September 13, 2001

a second comparator that compares the identified program content with a program reference tag provided by the program reference tag history database and generates a verification signal;

a second output module that generates a fulfillment signal based upon the approval signal and the verification signal; and

a media download device for receiving media corresponding to said purchase request over a communications network.

Claim 10 (original): The system as in Claim 9, wherein said user input control is a button.

Claim 11 (original): The system as in Claim 9, wherein said user input control is a voice command device.

Claim 12 (original): The system as in Claim 9, wherein the data stream conforms to the Radio Broadcast Data System Standard.

Claim 13 (currently amended): The system as in Claim 9, wherein the data stream conforms to the Radio Data Service System Standard.

Claim 14 (currently amended): The system as in Claim 9, wherein the transmitter first output module uses a wireless connection.

Claim 15 (currently amended): The system as in Claim 9, wherein the transmitter first output module uses an interface with a computer.

Claim 16 (withdrawn): A response authentication system for processing requests sent in response to a data stream embedded within a broadcast radio signal, comprising:

a database that contains customer information;

a database that correlates a data stream identifier code with a location of the data stream on a communications network;

a server that correlates the receipt of a request for a specified data stream with information contained in the data stream location database, the request generated by user response to the broadcast radio signal having a program portion and a data portion, said data portion identifying said program portion; and

an order fulfillment server that receives communication of customer information.

Appl. No. : 09/953,335
Filed : September 13, 2001

Claim 17 (withdrawn): The system as in Claim 16, wherein a completed order results in a download of a file corresponding to the specified data stream.

Claim 18 (withdrawn): The system of Claim 16, wherein the data stream identifier code is extracted from identification information stored on a compact disc.

Claim 19 (currently amended): A method of providing a response to a data stream embedded within a broadcast channel, comprising, in no particular order: ~~the steps of:~~

identifying an audio stream that is to be transmitted over the broadcast channel;

communicating the audio stream identifier information to a database;

using the database to determine a program reference tag corresponding to the identified audio stream;

determining a broadcast source identifier tag corresponding to a broadcast station;

generating a data packet comprising the program reference tag, the broadcast source identifier tag and a tag that identifies the source of the database;

broadcasting the data packet as a first modulated signal stream and the audio stream as a second modulated signal stream;

~~extracting a digital data signal from a radio broadcast signal that comprises a modulated digital signal stream and a modulated analog signal stream;~~

demodulating the first modulated signal stream to extract the data packet;

~~demodulating the second modulated analog signal stream and playing the demodulated analog signal stream; and generating an audio signal;~~

~~displaying the digital data in a format that allows a user to identify and scroll through the contents of the digital data signal; and corresponding to the data packet for viewing by a user;~~

determining a user identifier tag;

preparing, in response to user input, a response packet comprising the program reference tag, the broadcast source identifier tag, and the user identifier tag;

~~transmitting a selection chosen from the displayed digital data by the user. the response packet to a response authentication system;~~

verifying the user identifier tag; and

acting on the response packet as directed by the verified user.

Appl. No. : 09/953,335
Filed : September 13, 2001

Claim 20 (original): A method of receiving responses to an audio broadcast, comprising:
broadcasting a signal comprising an audio signal and an accompanying identifying data signal, where the data signal identifies the audio signal, wherein the data signal is broadcast in a format that allows a receiver to display to a user information about the audio signal;

receiving a response from a user that identifies the user and the audio signal that the user is responding to;

verifying the user identification and the availability of the audio signal; and

acting on the user response.

Claim 21 (original): The method of Claim 20, wherein said acting on the user response comprises sending a media file.

Claim 22 (original): The method of Claim 20, wherein said acting on the user response comprises transacting a donation.

Claim 23 (original): The method of Claim 20, wherein said acting on the user response comprises sending a plurality of media files

Claim 24 (currently amended): A system for performing a transaction based on data provided as part of a broadcast signal, comprising:

a broadcast receiver circuit that extracts a data signal from a broadcast signal, said the broadcast signal comprising an audio stream, a video stream and a data stream, wherein the data stream comprises a unique program reference tag;

a display driver capable of displaying on a television screen information corresponding to the data signal;

a user input control that allows a user to ~~select a transaction~~ make a selection from the displayed information;

a first output module that provides an output signal comprising a program reference tag and a user reference tag, the output signal being provided to a program reference tag history database;

a first comparator that compares the user reference tag with stored user information and generates an approval signal;

Appl. No. : 09/953,335
Filed : September 13, 2001

a second comparator that compares the program reference tag with the unique program reference tag provided by the program reference tag history database and generates a verification signal; and

a second output module that generates a fulfillment signal based upon the approval signal and the verification signal.

~~an output device that provides a transaction request comprising an identity of a user and an identification of the selected transaction, said transaction request being provided to a response authentication system.~~

Claim 25 (currently amended): A system for performing a transaction based on data provided as part of a broadcast signal, comprising:

a broadcast receiver circuit that extracts a data signal from a broadcast radio-frequency signal, said the broadcast signal comprising an audio stream and a data stream;

a user input control that allows a user to initiate a transaction based on the audio stream content;

a first output module that provides an output signal comprising a program reference tag and a user reference tag, the output signal being provided to a program reference tag history database;

a first comparator that compares the user reference tag with stored user information and generates an approval signal;

a second comparator that compares the program reference tag with the unique program reference tag provided by the program reference tag history database and generates a verification signal; and

a second output module that generates a fulfillment signal based upon the approval signal and the verification signal.

~~an output device that provides a transaction request comprising an identity of a user and an identification of the selected transaction, said transaction request being provided to a response authentication system.~~

Appl. No. : 09/953,335
Filed : September 13, 2001

Claim 26 (currently amended): A system for performing a transaction based on data provided as part of a broadcast radio-frequency signal, comprising:

a means for ~~extracting~~ receiving a data signal from a broadcast channel, said broadcast channel comprising an audio stream and a data stream that identifies program material in the audio stream;

a means for displaying information corresponding to the data signal;

a means for allowing a user to select a transaction from the displayed information;

a means for requesting a transaction, said transaction request comprising an identity of a user and an identification of the selected transaction, said transaction request being provided to a response authentication system.

Appl. No. : 09/953,335
Filed : September 13, 2001

REMARKS

This communication is responsive to the June 27, 2003 Office Action. Claims 1-26 were previously pending in this application. Claims 1-15 and 19-26 were rejected under 35 U.S.C. § 103(a) as being unpatentable over U.S. Patent No. 5,303,393 to Noreen et al. (hereinafter "Noreen"). Claims 16-18 were withdrawn from further consideration by the examiner under 37 C.F.R. § 1.142(b) as being drawn to a non-elected invention.

Applicants would like to thank Examiner Kramer for the courtesies extended to Applicants' counsel, William B. Bunker, Applicant Kelly Christensen, and Tom Mock in a September 30, 2003 personal interview. A prototype radio was demonstrated, and amendments to Claim 1 were discussed. The Noreen patent cited in the Office Action was also discussed. Applicants would further like to thank Examiner Kramer for the courtesies extended to Applicants' counsel, William B. Bunker, in an October 29, 2003 personal interview. A demonstration of receiving a confirmation notice on a cellular telephone was shown to the examiner. Amendments to Claims 1 and 19 were discussed. The Noreen patent was also discussed. No specific agreement was reached in either interview; however, the Examiner agreed to favorably consider the proposed amendments.

As was discussed at the interview, Noreen discloses satellite broadcasting. Noreen does not render the pending claims unpatentable under 35 U.S.C. §§ 102 or 103.

Claims 1-15 and 19-26 were rejected under 35 U.S.C. § 103(a) as being unpatentable over Noreen and on assertions that several facts were well-known in the art. Applicants respectfully traverse the official notice taken by the Examiner. M.P.E.P. § 2144.03 states that "[i]n limited circumstances, it is appropriate for an examiner to take official notice of facts not in the record or to rely on 'common knowledge' in making a rejection, however, such rejections should be judiciously applied. . . . Official notice unsupported by documentary evidence should only be taken by the examiner where the facts asserted to be well-known, or to be common knowledge in the art are capable of instant and unquestionable demonstration as being well-known."

Applicants respectfully traverse that it is well known in the art to use a parallel port or serial port for connecting a broadcast receiver to a network. Applicants further respectfully traverse that media download devices to receive purchased digital content in a mobile environment are old and well known in the art. Finally, Applicants respectfully traverse that it would merely be a design choice to use the RBDS data signal in the claimed manner.

Appl. No. : 09/953,335
Filed : September 13, 2001

Applicants respectfully traverse the grouping of Claims 1-15 and 19-26 to make the rejection. *See, e.g.*, M.P.E.P. § 707.07(d) ("A plurality of claims should never be grouped together in a common rejection, unless that rejection is equally applicable to all claims in the group"). Further, the rejections fail to address each of the limitations recited in the claims.

In an attempt to further the prosecution, Applicants hereby amend Claims 1, 3, 5-9, 13-15, 19, and 24-26. Claims 1-15 and 19-26 are pending and presented for further consideration. Reconsideration of the application, as amended, is therefore respectfully requested.

Submitted concurrently herewith is a Supplemental Information Disclosure Statement and form PTO-1449 citing 13 new references that recently came to Applicants' attention. Applicant respectfully requests the Examiner to consider these references in connection with the pending claims. Copies of the references will be sent under separate cover.

CONCLUSION

Applicants have endeavored to address all of the Examiner's concerns as expressed in the outstanding Office Action. In light of the above remarks, reconsideration and withdrawal of the outstanding rejections is specifically requested.

In view of the foregoing amendments and remarks, Applicants submit that the claims are patentably distinct from the cited art, and request that the application be allowed.

Applicants respectfully submit that the claims are in condition for allowance. Furthermore, any remarks in support of patentability of one claim should not be imputed to any other claim, even if similar terminology is used. Any remarks referring to only a portion of a claim should not be understood to base patentability on that portion; rather, patentability must rest on each claim taken as a whole. Applicant respectfully traverses each of the Examiner's rejections and each of the Examiner's assertions regarding what the prior art shows or teaches, even if not expressly discussed herein. Although changes to the claims have been made, no acquiescence or estoppel is or should be implied thereby; such amendments are made only to expedite prosecution of the present application and are without prejudice to the presentation or assertion, in the future, of claims relating to the same or similar subject matter.

If the Examiner finds any remaining impediment to the prompt allowance of these claims that could be clarified with a telephone conference, the Examiner is respectfully requested to initiate the same with the undersigned attorney of record at his direct dial number of (949) 721-2961.

Appl. No. : 09/953,335
Filed : September 13, 2001

Please charge any additional fees, including any fees for additional extension of time, or credit overpayment to Deposit Account No. 11-1410.

Respectfully submitted,

KNOBBE, MARTENS, OLSON & BEAR, LLP

Dated: 11/25/2003

By: Perry D. Oldham
Perry D. Oldham
Registration No. 52,082
Attorney of Record
Customer No. 20,995
(949) 760-0404

H:\DOCS\PDO\PDO-2191.DOC
103103

[Handwritten signature]
[Handwritten number 8]

Docket No.: STRATOS.001A

Customer No. 20,995

INFORMATION DISCLOSURE STATEMENT

| | | |
|----------------|---|---|
| Applicant | : | Kelly Christensen et al. |
| App. No. | : | 09/953,335 |
| Filed | : | September 13, 2001 |
| For | : | SYSTEM AND METHOD FOR ORDERING AND DELIVERING MEDIA CONTENT |
| Examiner | : | James Kramer |
| Group Art Unit | : | 3627 |

Commissioner for Patents
P.O. Box 1450
Alexandria, VA 22313-1450

Dear Sir:

Enclosed is form PTO-1449 listing 13 references that are also enclosed.

This Information Disclosure Statement is being filed before the mailing date of a final action under 37 C.F.R. § 1.113 and before the mailing date of a Notice of Allowance under § 1.311. A certification under 37 C.F.R. § 1.97(e) is set forth below. Thus, no fee is required as set forth in 37 C.F.R. § 1.97(c).

CERTIFICATION UNDER 37 C.F.R. § 1.97(e)(1)

I hereby certify that each item of information contained in this Statement was first cited in a communication from a foreign Patent Office in a counterpart foreign application not more than three months prior to the filing of this Information Disclosure Statement.

Respectfully submitted,
KNOBBE, MARTENS, OLSON & BEAR, LLP

Dated: 11/25/2003

By: *Perry D. Oldham*
Perry D. Oldham
Registration No. 52,082
Attorney of Record
Customer No. 20,995
(949) 760-0404

H:\DOCS\PDOP\DO-2226.DOC
112503

| | | |
|---|--|-------------------------------|
| FORM PTO-1449 U.S. DEPARTMENT OF COMMERCE PATENT AND TRADEMARK OFFICE INFORMATION DISCLOSURE STATEMENT BY APPLICANT (USE SEVERAL SHEETS IF NECESSARY) | ATTY. DOCKET NO. STRATOS.001A | APPLICATION NO. 09/953,335 |
| | APPLICANT Kelly M. Christensen, et al | |
| | FILING DATE September 13, 2001 | GROUP 3627 |

| U.S. PATENT DOCUMENTS | | | | | | | |
|-----------------------|----|-----------------|---------|----------------|-------|----------|------------------------------|
| EXAMINER INITIAL | | DOCUMENT NUMBER | DATE | NAME | CLASS | SUBCLASS | FILING DATE (IF APPROPRIATE) |
| | 1. | US2003/0097338 | 5/22/03 | Manovich et al | | | |

| FOREIGN PATENT DOCUMENTS | | | | | | | | |
|--------------------------|----|------------------|---------|--------------------|-------|----------|-------------|----|
| EXAMINER INITIAL | | DOCUMENT NUMBER | DATE | COUNTRY | CLASS | SUBCLASS | TRANSLATION | |
| | | | | | | | YES | NO |
| | 2 | PCT/GB92/00181 | 8/20/92 | Tait et al | | | | |
| | 3 | PCT/GB93/01526 | 2/3/94 | Tait et al | | | | |
| | 4 | PCT/CA96/00794 | 6/12/97 | Michael Pocock | | | | |
| | 5 | PCT/FI97/00315 | 12/4/97 | Behruz Vazvan | | | | |
| | 6 | PCT/US00/17157 | 1/4/01 | Davis et al | | | | |
| | 7 | PCT/US01/02781 | 8/9/01 | S. Jeffrey | | | | |
| | 8 | EP 0 713 335 A2 | 5/22/96 | August et al | | | | |
| | 9 | DE 44 27 046 A1 | 2/1/96 | Goidscheider et al | | | | |
| | 10 | DE 196 27 308 A1 | 1/2/98 | Dr. Peter Mihatsch | | | | |
| | 11 | 10-135855 | 5/22/98 | Japanese Patent | | | | |

| EXAMINER INITIAL | OTHER DOCUMENTS (INCLUDING AUTHOR, TITLE, DATE, PERTINENT PAGES, ETC.) |
|------------------|---|
| | 12 "Bookmark Your World", 1999- 2000 Xenote, www.xenote.com |
| | 13 1/25/00, Showcase 2000 - Xenote Press Release re Xenote iTag, www.xenote.com/html/press/realases.html |
| | 14 |
| | 15 |
| | 16 |

H:\DOCS\IPDO\PDO-2211.DOC
111003

| | |
|--|-----------------|
| EXAMINER | DATE CONSIDERED |
| *EXAMINER: INITIAL IF CITATION CONSIDERED, WHETHER OR NOT CITATION IS IN CONFORMANCE WITH MPEP 609; DRAW LINE THROUGH CITATION IF NOT IN CONFORMANCE AND NOT CONSIDERED, INCLUDE COPY OF THIS FORM WITH NEXT COMMUNICATION TO APPLICANT. | |



INTERNATIONAL APPLICATION PUBLISHED UNDER THE PATENT COOPERATION TREATY (PCT)

| | | |
|--|------------------|---|
| <p>(51) International Patent Classification ⁵ : G07F 7/10</p> | <p>A1</p> | <p>(11) International Publication Number: WO 92/142 (43) International Publication Date: 20 August 1992 (20.08)</p> |
| <p>(21) International Application Number: PCT/GB92/00181 (22) International Filing Date: 31 January 1992 (31.01.92) (30) Priority data: 9102104.8 31 January 1991 (31.01.91) GB (71)(72) Applicants and Inventors: TAIT, Robert, Alan, Reid [GB/GB]; TAIT, Elizabeth, Mary [GB/GB]; 5 Bridge-castle, Westfield, Bathgate, East Lothian EH48 3DU (GB). (74) Agent: NAISMITH, Robert, Stewart; Cruikshank & Fairweather, 19 Royal Exchange Square, Glasgow G1 3AE (GB).</p> | | <p>(81) Designated States: AT (European patent), AU, BE (European patent), CA, CH (European patent), DE (European patent), DK (European patent), ES (European patent), FR (European patent), GB, GB (European patent), GR (European patent), HU, IT (European patent), LU (European patent), MC (European patent), NL (European patent), SE (European patent), US.</p> <p>Published <i>With international search report. Before the expiration of the time limit for amending claims and to be republished in the event of the receipt of amendments.</i></p> |

(54) Title: **NON-CONTACTING TRANSACTION SYSTEM**

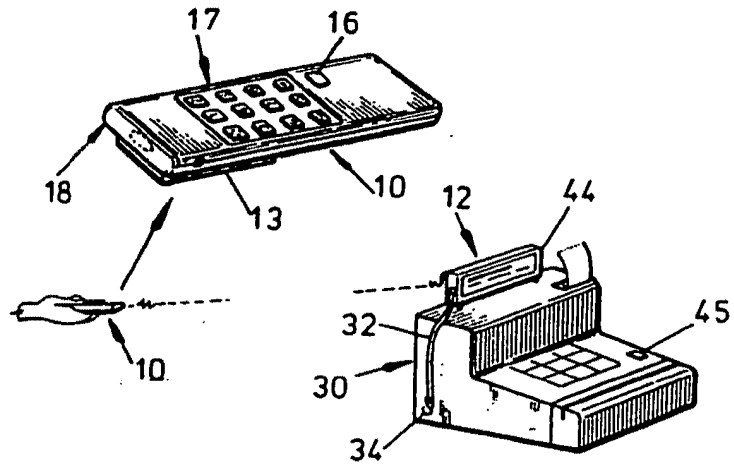

(57) Abstract

A non-contacting transaction system as described which includes a hand-held device (10) which contains information unique to the user and which, when actuated by the user, generates a wireless signal which is picked up by a receiver (12). In a preferred arrangement, the transmitter (10) contains the user's code and has a keypad (17) for the user to insert a personal identification number (PIN) code. The receiver (12) is coupled via a transmission line to a local system where the user's code and PIN number and details of the purchase, received from the vendor, are registered against the user's number so that billing can be carried out subsequently. The receiver (10) can include a means for checking (27) and for rectifying the correctness of the code: a PIN number prior to transmitting the data via the modem to the central system. Various embodiments of the invention are described; for example, the device is flexible and the PIN number could be required for all transactions to minimise fraud. Each transmitter may be provided with a terminal to allow an input to the memory for changing details of the user's account: a charge number. To prove ownership of the transmitter, the owner's name, telephone number, car registration number etc. may also be fused in the memory along with the credit card number. This information would be displayed only to the vendor who could ask the person who was using the transmitter to identify himself by name, PIN, telephone number or car registration as proof of identity.

FOR THE PURPOSES OF INFORMATION ONLY

Codes used to identify States party to the PCT on the front pages of pamphlets publishing international applications under the PCT.

| | | | | | |
|----|--------------------------|----|---------------------------------------|----|--------------------------|
| AT | Austria | FI | Finland | MI | Mali |
| AU | Australia | FR | France | MN | Mongolia |
| BB | Barbados | GA | Gabon | MR | Mauritania |
| BE | Belgium | GB | United Kingdom | MW | Malawi |
| BF | Burkina Faso | GN | Guinea | NI | Netherlands |
| BG | Bulgaria | GR | Greece | NO | Norway |
| BJ | Benin | HU | Hungary | PL | Poland |
| BR | Brazil | IE | Ireland | RO | Romania |
| CA | Canada | IT | Italy | RU | Russian Federation |
| CF | Central African Republic | JP | Japan | SD | Sudan |
| CG | Congo | KP | Democratic People's Republic of Korea | SE | Sweden |
| CH | Switzerland | KR | Republic of Korea | SN | Senegal |
| CI | Côte d'Ivoire | LI | Liechtenstein | SU | Soviet Union |
| CM | Cameroon | LK | Sri Lanka | TD | Chad |
| CS | Czechoslovakia | LU | Luxembourg | TC | Togo |
| DE | Germany | MC | Monaco | US | United States of America |
| DK | Denmark | MG | Madagascar | | |
| ES | Spain | | | | |

NON-CONTACTING TRANSACTION SYSTEM

The present invention relates to apparatus for logging data of transactions and particularly, but not exclusively, the invention relates to apparatus for recording cashless financial transactions.

It is now widely accepted that purchasing goods or services in the domestic sector is more efficiently carried out if the purchase transaction does not use cash. Cash is often perceived as, at best, cumbersome and, at worst, an unnecessary risk to personal safety, for example, from muggings and also financially, from theft. Current trends are to move towards a "cashless society" and the momentum of this trend is gaining the support nationally and internationally.

The existence of credit cards goes quite a long way to meet the ideal requirements in respect of cashless transactions. For example, it contains the owner's identity number imprinted on a magnetic strip on the back of the card, together with the owner's name embossed on the front of the card. A holograph of the owner's signature is written on the back of the card and is the only means of confirming the correct ownership of the card.

Nevertheless, the present type of credit card has severe limitations in providing the ideal solution for a cashless transaction. For such a transaction to

commence, the credit card must physically come into contact with either a paper voucher on which the embossed details are transferred by carbon copy or the card must be physically passed through a swipe machine so that the magnetic strip is electro-magnetically read by a magnetic head. Both of these techniques require intimate physical contact of a machine with a credit card. The next step in the transaction is for the owner of the credit card to append his signature on the paper voucher. The vendor in the transaction compares, or should compare, the signature on the back of the card with that on the voucher. Assuming that there is a fair degree of resemblance between the signatures, the vendor then accepts that the transaction is complete. In order for the card owner's account to be debited, the vendor either sends copies of the carbon slips to the credit card company or the information from the magnetic swipe reader is electronically stored and usually transmitted over a telephone link. In the former case, one of the problems is loss of credit card slips or even damage to the slips such as to render details of the credit card unusable, with the result that the owner's account does not get debited and this results in a loss to the vendor. In the case of a card swipe machine, the information is periodically scanned from a central computer which polls all the swipe machines to which it is linked and the details of the transaction are then fed to a central

storage location where the information is then entered into the user's account and a bill is then prepared and sent to the user.

One problem with the existing system is that card fraud is very easily perpetrated. This is mainly because the signature appears on the reverse side of the card. A signature can generally be perfected by repeated copying so that it appears similar to that on the card. The unauthorised user of the card can then forge the signature to complete a fraudulent transaction. Even if a stolen or lost card is reported, there is often considerable time before all premises and businesses accepting that type of card are notified. In the case of a swipe card, notification is carried out remotely and periodically over the telephone line. Nevertheless, a professional criminal is able to verify whether the card is still valid with minimal risk and to use the card on a day-to-day basis with minimal risk of being apprehended.

A further disadvantage of existing credit card systems is that it is not possible to use the card without physical contact. Therefore, it is not presently feasible to use a credit card for parking, for paying tolls on a toll road or bridge or the like and in such situations, cash is still the preferred method of payment.

An object of the present invention is to obviate or mitigate at least one of the aforementioned disadvantages.

This is achieved by providing a hand-held transmitter

which contains information unique to the user and which, when actuated by the user, generates a wireless signal which is picked up by a receiver. In a preferred arrangement, the transmitter contains the user's code and has a keypad for the user to insert a personal identification number (PIN) code. The receiver is coupled via a transmission line to a local system where the user's code and PIN number and details of the purchase, received from the vendor, are registered against the user's number so that billing can be carried out subsequently.

The receiver can include a means for checking and for rectifying the correctness of the code and PIN number prior to transmitting the data via the modem to the central system. The device is flexible and the PIN number could be required for all transactions to minimise fraud. Each transmitter may be provided with a terminal to allow an input to the memory for changing details of the user's account and charge number. To prove ownership of the transmitter, the owner's name, telephone number, car registration number etc. may also be fused in the memory along with the credit card number. This information would be displayed only to the vendor who could ask the person who was using the transmitter to identify himself by name, PIN, telephone number or car registration as proof of identity.

An object of the present invention is to obviate or

mitigate at least one of the aforementioned disadvantages.

According to one aspect of the present invention, there is provided a non-contacting transaction system comprising,

transmitter means having a memory for storage of data identifying the user therein, and a transmitter for transmitting the stored data to a remote location upon actuation of the transmitter means by the user, and

receiver means for receiving the transmitted data and having indicator means for indicating that the data transmitted is received and that the transaction can proceed.

Preferably, the transmitter means includes a keypad for the user to insert details of a PIN number. Conveniently, the transmitter means includes a terminal coupled to said memory whereby the transmitter can be coupled to a control means whereby the information in said memory may be changed or supplemented.

The transmitter includes a switch actuatable by the user which results in the stored data being continually transmitted or transmitted in bursts during the transmitting actuation.

Conveniently, the receiver may be coupled by a modem or the like over the telephone network to a central data processing and storage unit where details of the transactions are allocated to the user's account for subsequent billing.

Alternatively, the receiver may include disk storage means or other suitable mass storage means for storing validated transactions for subsequent despatching of the stored transaction data to the central data processing and storage unit at a later date.

Conveniently, the receiver includes a display for displaying to the vendor the transmitted information. Advantageously, the receiver includes parity and code check means for rectifying the correctness of the received code prior to transmitting it to the modem.

According to another aspect of the invention, there is provided a transmitter for use in a non-contacting transaction system, said transmitter comprising a memory for storing data identifying the user, a transmitter coupled to the memory for wireless transmission of said stored data to a remote location, and switch means actuatable by the user for causing said stored data to be transmitted.

Preferably, the transmitter includes a keypad for the user to insert details of a personal identification number (PIN), and said data being transmitted only if the correct PIN number is keyed in.

Conveniently, the transmitter includes a terminal coupled to the memory whereby the transmitter can be coupled to a control means to change the information in said memory.

Preferably also, the transmitter includes a plurality

of keys representative of different user accounts and the user can nominate which account a transaction is to be attributed to by selecting the appropriate key.

The transmitter is an infra-red transmitter.

Alternatively, the transmitter may include a remote telephone console interfaced to said memory and keys whereby a user may remotely conduct a transaction using radio frequency communications or any part of the electro-magnetic spectrum for communications.

According to a further aspect of the invention, there is provided a receiver for use in a non-contacting transaction system, said receiver comprising a data receiver for receiving a wireless transmission, means for indicating that the data has been received, means for processing the received data for display, means for verifying the correctness of the data received, and display means for displaying to a vendor details of the user stored in said transmitter.

Preferably, the receiver is coupled to a card swipe machine. Conveniently, the receiver and/or card swipe machine are coupled to a cellular telephone network for receiving said data by radio frequency communication. Conveniently, the receiver may be coupled by a modem or the like over the telephone network to a central data processing and storage unit where details of the transactions are allocated to the user's account for subsequent billing.

Alternatively, the receiver may include disk storage means or other suitable storage means for storing validated transactions for subsequent despatching of the stored transaction data to the central data processing and storage unit at a later date.

Thus, the invention provides a considerable improvement over existing cash cards to satisfy requirements for cashless transactions. The invention permits cashless transactions to be performed in a non-contacting fashion and it provides a secure method of checking and verifying the identity of the vendor without requiring signatures.

These and other aspects of the present invention will become apparent from the following description when taken in combination with the accompanying drawings in which:-

Fig. 1 is a diagrammatic view of a system consisting of a transmitter and a receiver shown coupled to a card swipe machine in accordance with one aspect of the present invention;

Fig. 2 is a diagrammatic view of an alternative transmitter similar to that shown in Fig. 1 and which includes a keyboard and a set of credit card select buttons;

Fig. 3a and 3b are schematic block diagrams of the transmitter and receiver, respectively shown in Fig. 1;

Fig. 4 is a schematic block diagram of the transmitter shown in Fig. 2;

Fig 5 is a schematic block diagram of an alternative transmitter similar to that of Figs. 1 and 2, but which has no keypad;

Fig. 6 depicts a flow chart of the operation of the transmitter and receiver conducted by a user in the pursuit of purchasing a commodity using the transmitter and receiver shown in Fig. 1;

Fig. 7 and Fig. 8 depict flow charts which are similar to Fig. 6, but using the transmitters of Fig 2 and Fig. 3 respectively, and

Fig. 9 is a circuit diagram of an embodiment of an infra-red transmitter in accordance with the present invention.

Reference is first made to Fig. 1 of the drawings which depicts a hand-held transmitter 10 and receiver 12 in accordance with the first embodiment of the invention. As will be later described in detail, the transmitter 10, when actuated, transmits information about the user which is received by the receiver 12 and used to initiate the transaction. The transmitter is about 10cm long and has a clip 13 for securing in a pocket or the like. The transmitter has a switch 16 and an infra-red filter 18 at one end of the transmitter. The transmitter also has a keypad 17 which enables high value transactions to be carried out by combining the stored credit card or account number with a personal identification number (PIN).

Reference is also made to Fig. 3a, 3b and Fig. 6 of

the drawings which are a schematic block diagram of the transmitter and receiver circuits and a flow chart of the operations involved in a transaction using the transmitter/receiver arrangement of Fig. 1. The transmitter 10 contains a programmable read only memory (PROM) chip 20 in which the owner's personal credit number (i.e. similar to a credit card number or bank number etc.) is electronically stored. The owner's name or other identifying number such as vehicle registration number or community charge number, is also stored. When the switch 16 is depressed, power is applied to the circuit from the battery 22 and the information contained in the PROM 20 is only transferred in parallel using the clock 24, to the shift register 26 only if the correct PIN number is inserted via the keypad 17. The keyed-in PIN number is compared in comparator 27 with the fused PIN number, and only if they match is the information transferred to shift register 26. The identity part of the fused data, for example, the vendee's name or community charge number or driving licence number, can be checked as previously mentioned. This further improves the security as the PIN number is known only to the user and will provide at least the same level of security as with a bank charge card for use with High Street terminals and the like. the information received in the shift register 26 is then transferred to the infra-red transmitter 28, in serial form, and clocked by the clock 24 for transmission. The

infra-red filter 18 is a notch filter selected to best suit infra-red transmission.

Thus, in practice, the vendee or user can transfer his personal credit details in a non-contacting, remote fashion in the infra-red waveband. Of course, it will be appreciated that transmission might be in any suitable part of the electro-magnetic spectrum, not necessarily at infra-red wavelengths.

The transmitted data is received by the receiver 12 which is coupled to a conventional card swipe machine 30 by a cable and connector 32,34 respectively. As best seen from the receiver schematic block diagram in Fig. 3b, the data is received by a suitable infra-red receiver 36 in serial form and the receiver then assembles the data into parallel format for the shift register 38. The parallel data is checked for parity in the code corrector 40 and any precoded format of data using a protocol circuit 42 prior to being transferred to the card swipe machine 30.

Thus, the information in the transmitter is passed from the transmitter to the receiver and then to the card swipe machine without contact or from suffering from the aforementioned disadvantages.

The operation of the system in a cashless transaction is best described with reference to the flow chart shown in Fig. 6 of the drawings. The receiver 12 on the card swipe machine has a display panel 44 which displays the

contents of the identity part of the message, for example, the name of the user or vendee once the transmission is complete. Provided that the display panel 44 is out of sight of the vendee, the vendor can read the identity part of the message and verify with the vendee as to the contents of this part of the message, as shown in step 8 of Fig. 6. Assuming that the vendee is the owner of the transmitter, only he knows the detail of the identity part of the message and can give the correct answer. This can be readily checked by the vendor by simply comparing the answer with that displayed on the panel; step 9. If the vendor is satisfied of the user's identity, he then authorises the transaction to proceed by actuating a button 45 on the card swipe machine which accepts the user's transmitted data; step 10. Of course, if the vendee is not the owner of the transmitter, then the vendor can terminate the transaction, step 13. If, in fact, the vendee is not the owner of the transmitter, then only access to sophisticated electronic equipment would be required to interrogate the transmitter to enable misuse of the transmitter. Although this is, in theory, possible it is most unlikely that this facility would be available to criminals to carry out widespread fraud and the security achieved is far superior to that of comparing signatures.

Reference is now made to Figs, 2, 4 and 7 of the accompanying drawings which describe a further embodiment

of the invention. The transmitter 10a shown in Fig. 2 is similar to that shown in Fig. 1 in which like numerals denote like parts, but with the suffix 'a' added and which includes a facility for using the transmitter 10a with more than one credit card. This is achieved by providing a set of card select buttons 50, each of which can be selected by the user (step 3a, Fig. 7) in order to designate a particular transaction to a particular credit card. In this case, the individual owns several credit cards and wishes to have one transmitter to operate on behalf of all of the credit cards. Each card select button allows the operator to select the credit card which he wishes to use to complete the transaction. As shown in Fig. 4, the switches 50 are coupled to the PROM 20a and to the other components which contain the details appropriate to the card selected. Once the particular button has been depressed, the operation of the device is identical to that described with reference to Fig. 1.

The device can be used for low value transactions such as paying parking charges, paying tolls and the like and as security codes are regularly updated any loss and unauthorised use is likely to be insignificant. Moreover, the transaction is likely to be fully mechanised for the vendor. Reference is now made to Fig. 5 of the accompanying drawings which are for a transmitter of generally similar size and shape to the transmitter 10 shown in Fig. 1 except that it does not have a key-pad.

The circuit elements in Fig. 5 are referred to by like numerals, but by suffix 'b' added and operate in the same way. From Fig. 5 it will be seen that the basic operation is similar to the transmitter of Fig. 1 except that a PIN number is not employed. An example of how this circuit might be implemented is shown in Fig. 9. It comprises electronic elements where each and every one form part of the industry standard. ICs 1A and B might be a 74ALS14 or any suitable package containing 6 Schmitt trigger invertors; IC 2 is a 22V10 or any similar Programmable Array Logic configured to drive IC 3, an NMC9306, a 512-bit programmable serial read only memory. The resistors and capacitors are 1/4 watt, 5 percent tolerance components; a nominal 6 volt battery is employed. The light emitting diode D1 is similar to those used in television channel changers. The user's credit card number and the encryption element are fused in IC 3. These data are configured in an auto-clocking code, a 3 from 9 code being an example, ready for transmission. Implementation might also employ micro-processors/micro-controllers to reduce the component count within the transmitter. There are many such devices available, an example being COP8720C, or a COP424C with an accompanying NMC9306.

The receiver might be configured round a bar-code reader. One example is the Hewlett-Packard HBCR8500 which contains all the necessary electronics to convert

the data from the transmitter to ASCII, an international standard compatible with the majority of peripherals and swipe card machines.

Reference is now made to Figs. 5 and 8 of the accompanying drawings which are for a transmitter generally similar in size and shape to the transmitter 10 shown in Fig. 1 except that it does not have a keypad. The circuit elements in Fig. 5 are referred to by like numerals, but with the suffix 'b' added and operate in the same way. From Figs. 5 and 8 it will be seen that the basic operation is similar to the transmitter of Fig. 1 except that a PIN number is not entered, that is, step 5 is omitted. This device can be used for low value transactions such as paying parking charges, paying tolls and the like and as the security codes are regularly updated any loss and unauthorised use is likely to be insignificant.

It will be appreciated that various modifications may be made to the embodiments hereinbefore described without departing from the scope of the invention. For example, two chips may be combined in a transmitter; one chip containing the user's credit information, PIN number and the like, and a second chip containing an encryption algorithm so that the data transmitted is encrypted for more secure communications. Each receiver would have a corresponding chip with a decryption algorithm so that the transmitted information can be decoded and the stored

information displayed to the vendor. The size and shape of the transmitter may be varied and, in fact, depending on manufacturing technology, the transmitter may be credit card shaped to fit in a wallet or the like. The transmitter on such a credit card shape could also contain a keycard and credit card selector keys. The device and system could be used other than for financial transactions; it could be used to control entry or access to secure areas and the like, with the user's code (PIN) being verified at a local or central location.

The communication medium could be radio frequency (r.f.) sound or ultrasound suitable for carrying the necessary information to initiate a transaction, although it is believed that infra-red is the most suitable. A further modification is the addition of r.f. circuits to the transmitter and receiver so that the user is able to complete transactions remotely, in a similar manner to the operation of cardless cellular telephones. Thus, cinema theatre tickets and the like, could be ordered using the transmitter, and shopping could be done remotely with the receiver processing the order and automatically debiting the user's account.

The principal advantage of the invention is that it improves the security of cashless transactions and allows the transactions to be completed in a non-contacting fashion. Furthermore, it provides a more secure method of checking identity of the user without requiring

signatures. In addition, a single transmitter can be used to complete transactions for various cards and the transactions can be performed for purchasing any type of goods or service, including parking, paying tolls and the like which is not hitherto been possible with existing credit cards.

CLAIMS

1. A non-contacting transaction system comprising, transmitter means having a memory for storage of data identifying the user therein, and a transmitter for transmitting the stored data to a remote location upon actuation of the transmitter means by the user, and receiver means for receiving the transmitted data and having indicator means for indicating that the data transmitted is received and that the transaction can proceed.
2. A system as claimed in claim 1 wherein the transmitter means includes a keypad for the user to insert details of a PIN number.
3. A system as claimed in claim 1 or claim 2 wherein the transmitter means includes a terminal coupled to said memory whereby the transmitter is coupled to a control means whereby the information in said memory is alterable.
4. A system as claimed in claim 2 or claim 3 wherein the transmitter includes a switch actuatable by the user which results in the stored data being continually transmitted or transmitted in bursts during the transmitting actuation.
5. A system as claimed in any preceding claim wherein the receiver is coupled by a modem or the like over the telephone network to a central data processing and storage unit where details of the transactions are allocated to the user's account for subsequent billing.

6. A system has claimed in any one of claims 1- 4 wherein the receiver includes disk storage means or other suitable mass storage means for storing validated transactions for subsequent despatching of the stored transaction data to the central data processing and storage unit at a later date.

7. A system as claimed in any preceding claim wherein the receiver includes a display for displaying to the vendor the transmitted information.

8. A system as claimed in any preceding claim wherein the receiver includes parity and code check means for rectifying the correctness of the received code prior to transmitting it to the modem.

9. A transmitter for use in a non-contacting transaction system, said transmitter comprising a memory for storing data identifying the user, a transmitter coupled to the memory for wireless transmission of said stored data to a remote location, and switch means actuatable by the user for causing said stored data to be transmitted.

10. A transmitter as claimed in claim 9 wherein the transmitter includes a keypad for the user to insert details of a personal identification number (PIN), and said data being transmitted only if the correct PIN number is keyed in.

11. A transmitter as claimed in claim 9 or claim 10 wherein the transmitter includes a terminal coupled to the memory whereby the transmitter can be coupled to a control

means to change the information in said memory.

12. A transmitter as claimed in any one of claims 9 - 11 wherein the transmitter includes a plurality of keys representative of different user accounts and the user can nominate which account a transaction is to be attributed to by selecting the appropriate key.

13. A transmitter as claimed in any one of claims 9 - 12 wherein the transmitter is an infra-red transmitter.

14. A transmitter as claimed in any one of claims 9 - 15 wherein the transmitter may include a remote telephone console interfaced to said memory and keys whereby a user may remotely conduct a transaction using radio frequency communications or any part of the electro-magnetic spectrum for communications.

15. A receiver for use in a non-contacting transaction system, said receiver comprising a data receiver for receiving a wireless transmission, means for indicating that the data has been received, means for processing the received data for display, means for verifying the correctness of the data received, and display means for displaying to a vendor details of the user stored in said transmitter.

16. A receiver as claimed in claim 15 wherein the receiver is coupled to a card swipe machine.

17. A receiver as claimed in claim 15 or 16 wherein the receiver and/or card swipe machine are coupled to a cellular telephone network for receiving said data by

radio frequency communication.

18. A receiver as claimed in any one of claims 15 - 17 wherein the receiver is coupled by a modem or the like over the telephone network to a central data processing and storage unit where details of the transactions are allocated to the user's account for subsequent billing.

19. A receiver as claimed in any one of claims 15 - 17 wherein the receiver includes disk storage means or other suitable storage means for storing validated transactions for subsequent despatching of the stored transaction data to the central data processing and storage unit at a later date.

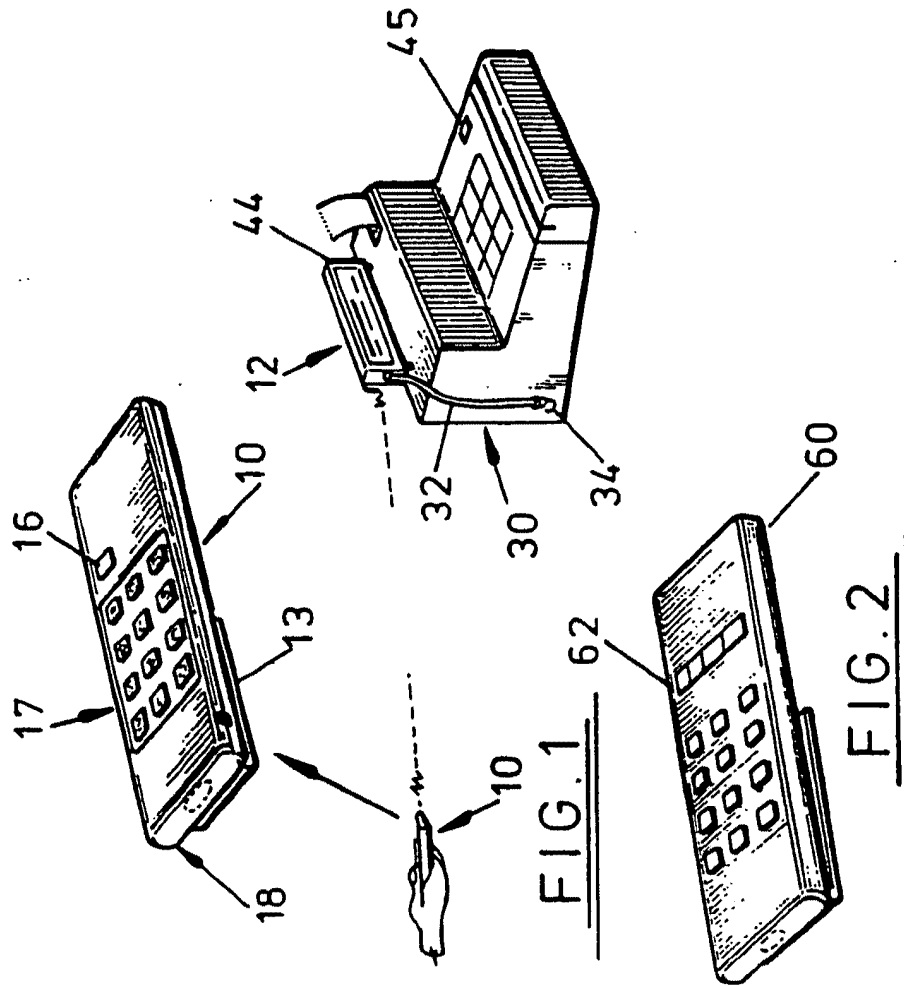

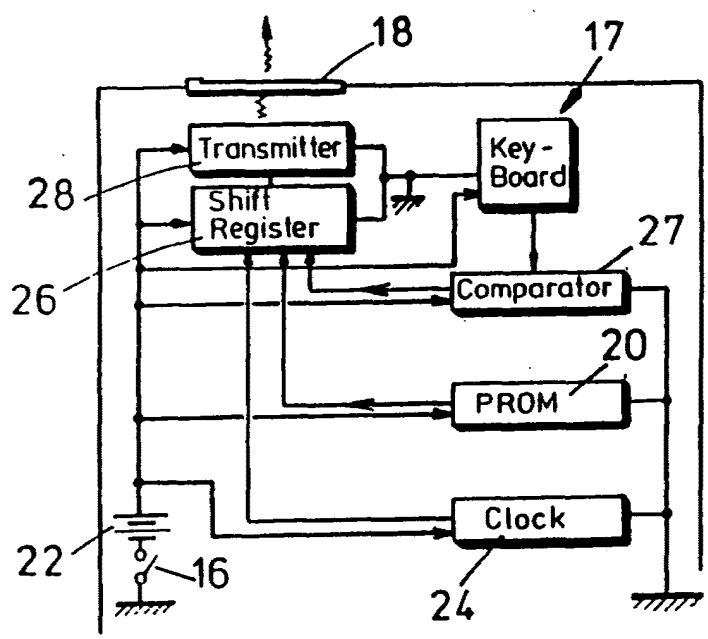

FIG. 3a

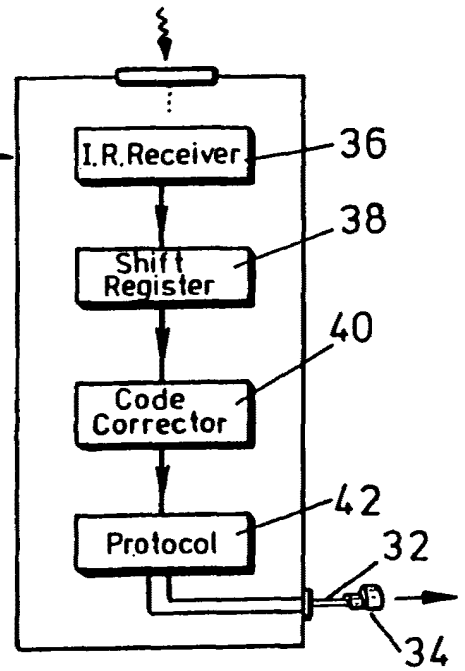

FIG. 3b

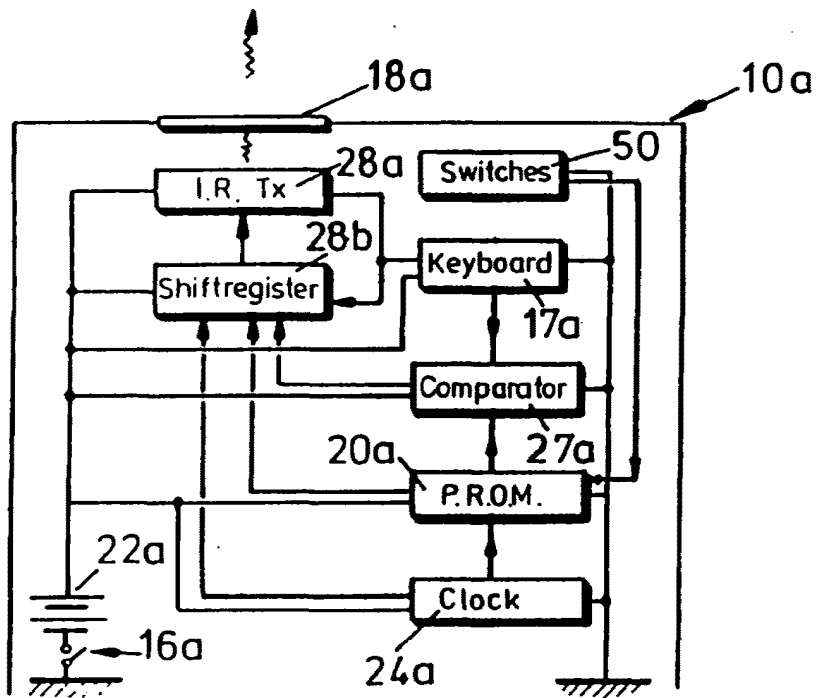

FIG. 4

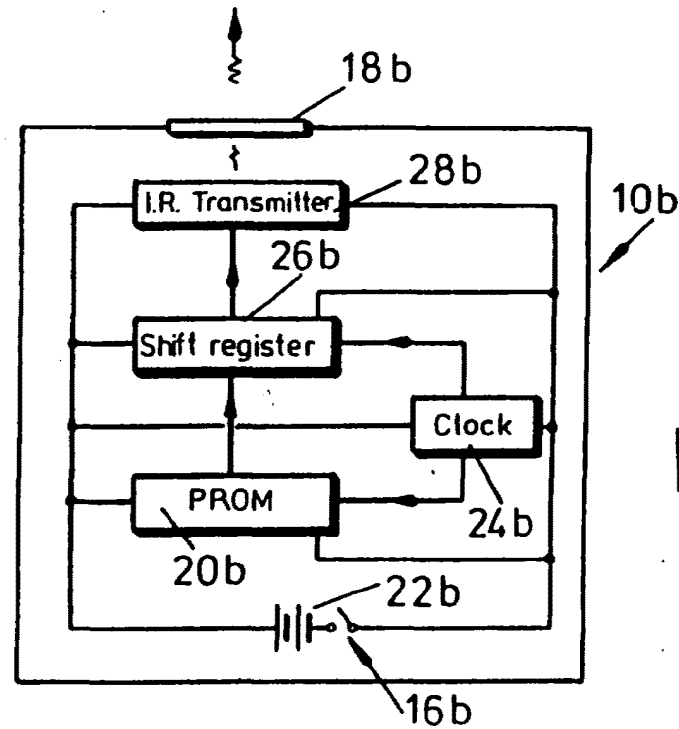

FIG. 5

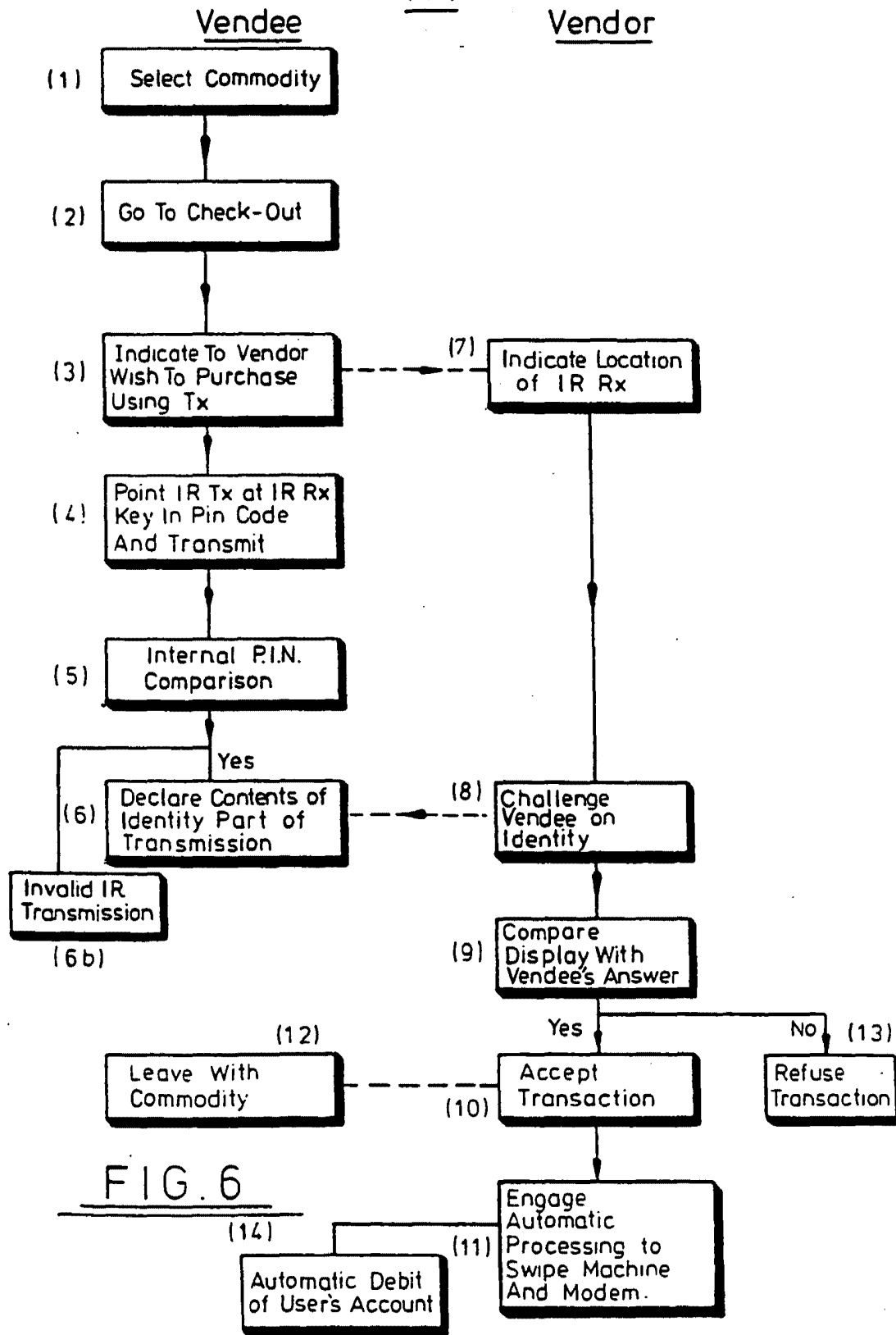

FIG. 6

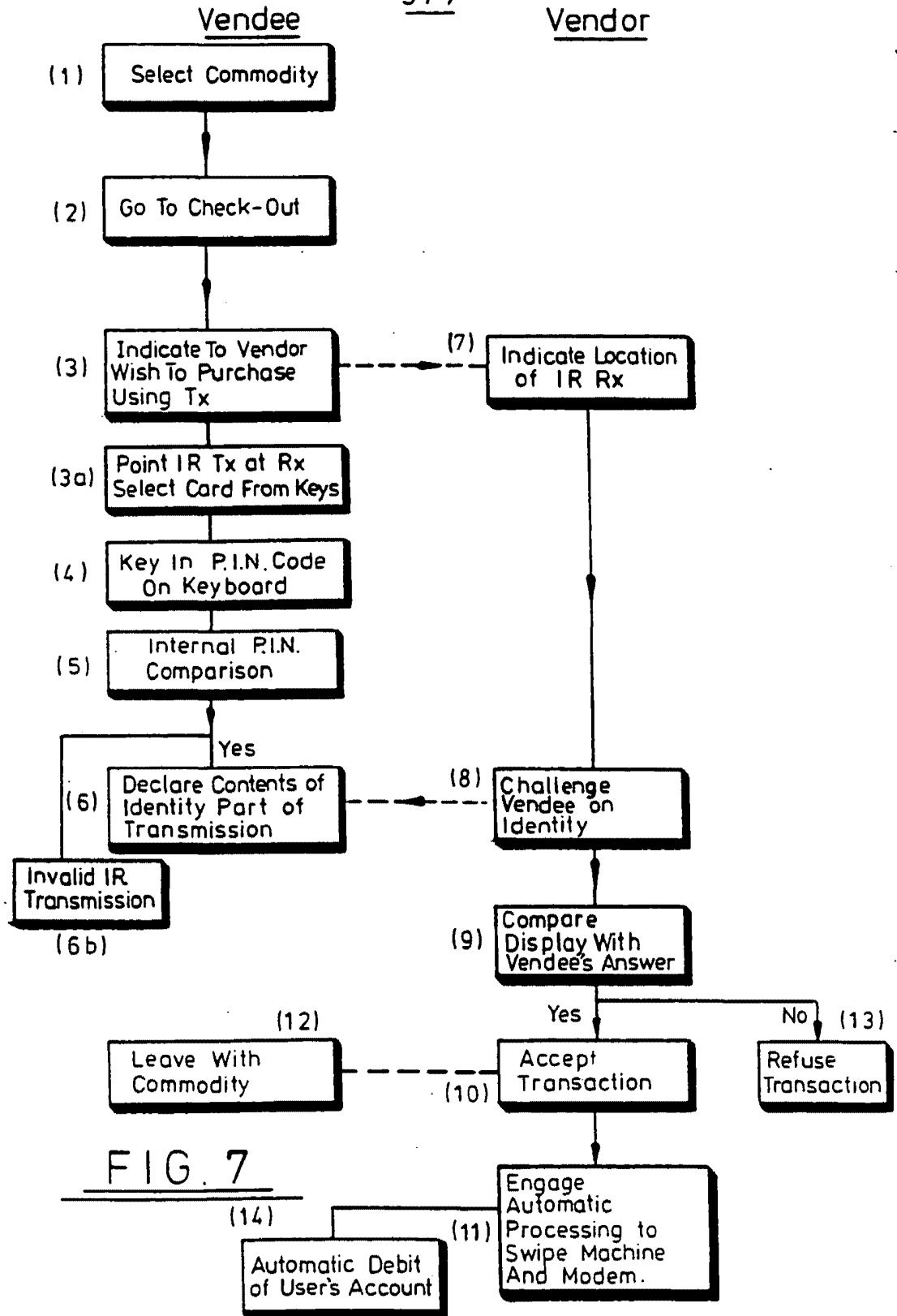
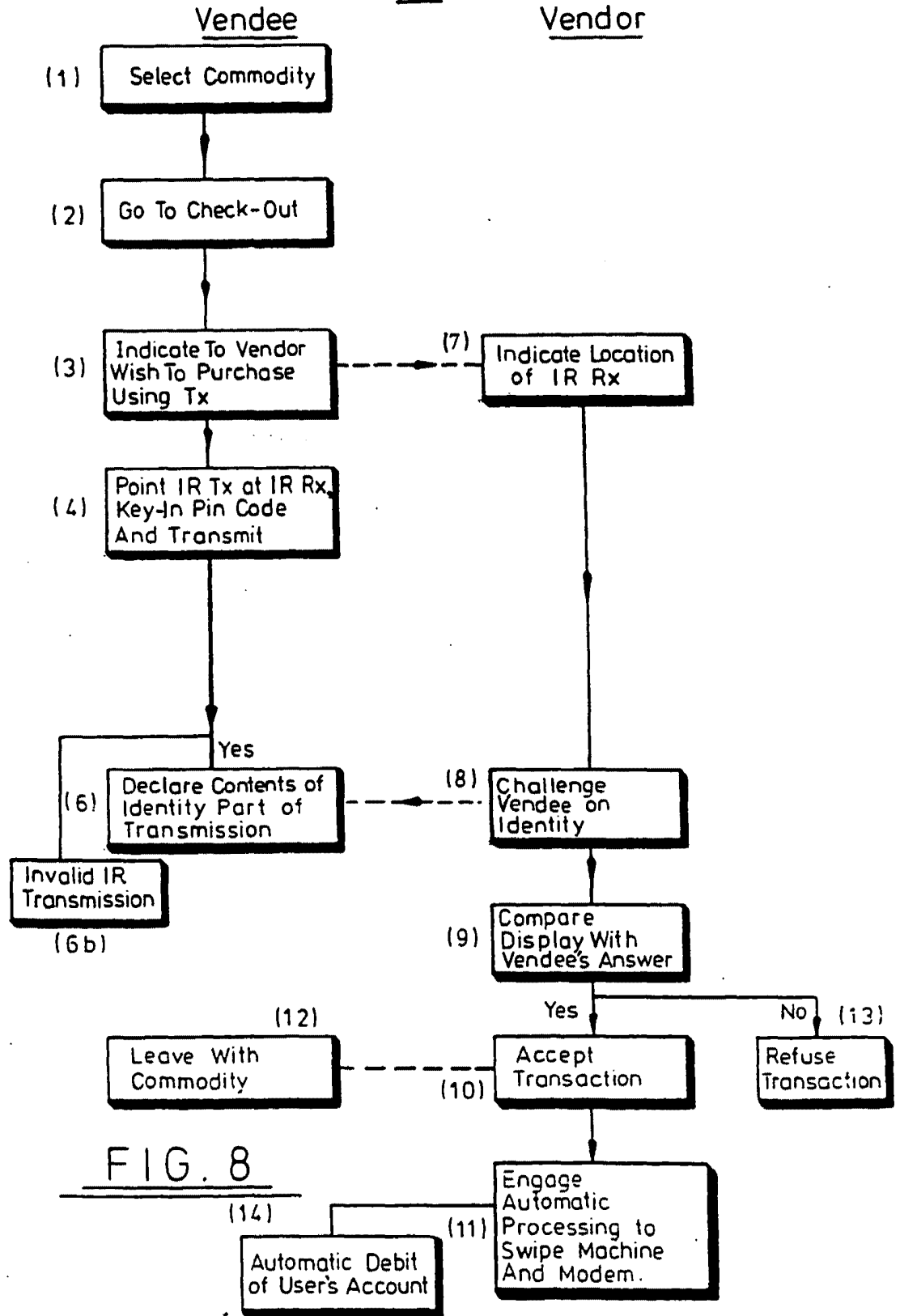

FIG. 7

SUBSTITUTE SHEET



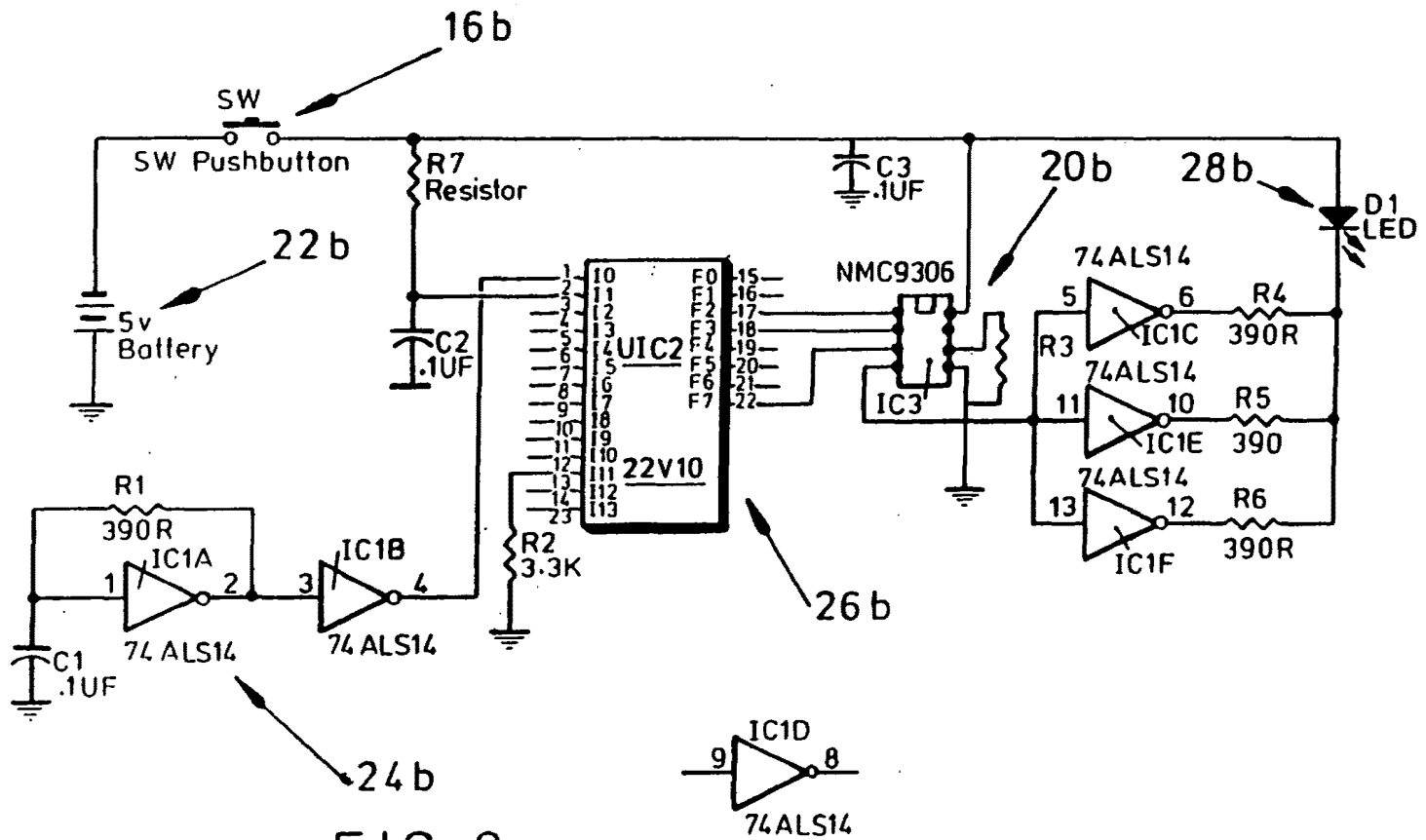

FIG. 9

**This Page is Inserted by IFW Indexing and Scanning
Operations and is not part of the Official Record**

BEST AVAILABLE IMAGES

Defective images within this document are accurate representations of the original documents submitted by the applicant.

Defects in the images include but are not limited to the items checked:

- BLACK BORDERS
- IMAGE CUT OFF AT TOP, BOTTOM OR SIDES
- FADED TEXT OR DRAWING
- BLURRED OR ILLEGIBLE TEXT OR DRAWING
- SKEWED/SLANTED IMAGES
- COLOR OR BLACK AND WHITE PHOTOGRAPHS
- GRAY SCALE DOCUMENTS
- LINES OR MARKS ON ORIGINAL DOCUMENT
- REFERENCE(S) OR EXHIBIT(S) SUBMITTED ARE POOR QUALITY
- OTHER: _____

IMAGES ARE BEST AVAILABLE COPY.

As rescanning these documents will not correct the image problems checked, please do not report these problems to the IFW Image Problem Mailbox.



INTERNATIONAL APPLICATION PUBLISHED UNDER THE PATENT COOPERATION TREATY (PCT)

| | | |
|---|------------------|--|
| <p>(51) International Patent Classification ⁵ : G06K 7/00, 17/00</p> | <p>A1</p> | <p>(11) International Publication Number: WO 94/0290 (43) International Publication Date: 3 February 1994 (03.02.94)</p> |
| <p>(21) International Application Number: PCT/GB93/01526 (22) International Filing Date: 21 July 1993 (21.07.93) (30) Priority data: 9215706.4 23 July 1992 (23.07.92) GB (71) Applicant (for all designated States except US): WHIN-HALL LIMITED [GB/GB]; 5 Bridgecastle Gardens, Bridgecastle, Westfield, Bathgate, West Lothian EH48 3DU (GB). (72) Inventors; and (75) Inventors/Applicants (for US only) : TAIT, Robert, Allen, Reid [GB/GB]; TAIT, Elizabeth, Mary [GB/GB]; 5 Bridgecastle Gardens, Bridgecastle, Westfield, Bathgate, West Lothian EH48 3DU (GB).</p> | | <p>(74) Agents: McCALLUM, William, Potter et al.; Cruikshan & Fairweather, 19 Royal Exchange Square, Glasgow G 3AE (GB). (81) Designated States: AU, CA, GB, HU, JP, US, Europea patent (AT, BE, CH, DE, DK, ES, FR, GB, GR, IE, IT, LU, MC, NL, PT, SE). Published <i>With international search report.</i></p> |

(54) Title: **NON-CONTACTING TRANSACTION SYSTEM FOR TICKETING**

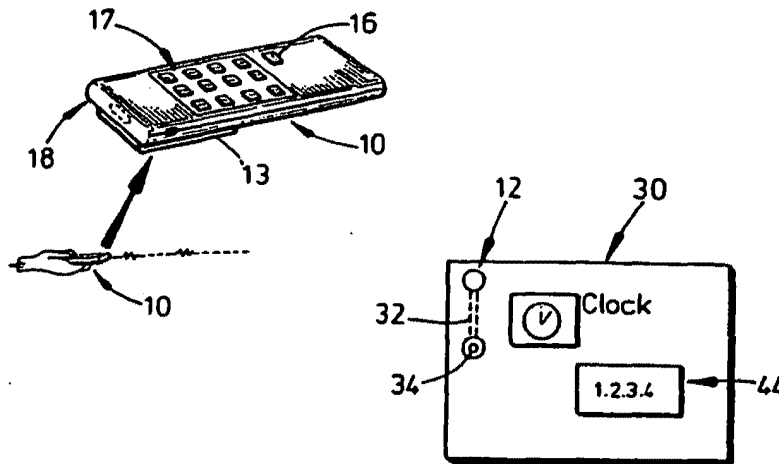

(57) Abstract

A non-contacting transaction system for ticketing is described which consists of a hand-held transmitter (10) which contains information unique to the user and which, when actuated by the user, generates a wireless signal which is picked up by a receiver (12). In a preferred arrangement, the transmitter (10) contains the user's code and has a keypad (17) for the user to insert a personal identification number (PIN) code. This PIN might be a series of digits or the owners telephone number, car registration number or any code preferred by the owner. The detectors of the receiver are coupled via a transmission line to a local system where the user's code and PIN number and details of the purchase, received from the vendor, are registered against the user's number so that billing can be carried out subsequently. The local system can include a means for checking and for rectifying the correctness of the code and PIN number prior to transmitting the data via the modem to the central system. The device is flexible and the PIN number could be required for all transactions to minimize fraud. Each transmitter may be provided with a terminal to allow an input to the memory for changing details of the user's account and charge number.

FOR THE PURPOSES OF INFORMATION ONLY

Codes used to identify States party to the PCT on the front pages of pamphlets publishing international applications under the PCT.

| | | | | | |
|----|--------------------------|----|--|----|--------------------------|
| AT | Austria | FR | France | MR | Mauritania |
| AU | Australia | GA | Gabon | MW | Malawi |
| BB | Barbados | GB | United Kingdom | NE | Niger |
| BE | Belgium | GN | Guinea | NL | Netherlands |
| BF | Burkina Faso | GR | Greece | NO | Norway |
| BG | Bulgaria | HU | Hungary | NZ | New Zealand |
| BJ | Benin | IE | Ireland | PL | Poland |
| BR | Brazil | IT | Italy | PT | Portugal |
| BY | Belarus | JP | Japan | RO | Romania |
| CA | Canada | KP | Democratic People's Republic of Korea | RU | Russian Federation |
| CF | Central African Republic | KR | Republic of Korea | SD | Sudan |
| CG | Congo | KZ | Kazakhstan | SE | Sweden |
| CH | Switzerland | LJ | Liechtenstein | SI | Slovenia |
| CI | Côte d'Ivoire | LK | Sri Lanka | SK | Slovak Republic |
| CM | Cameroon | LU | Luxembourg | SN | Senegal |
| CN | China | LV | Latvia | TD | Chad |
| CS | Czechoslovakia | MC | Monaco | TG | Togo |
| CZ | Czech Republic | MG | Madagascar | UA | Ukraine |
| DE | Germany | ML | Mali | US | United States of America |
| DK | Denmark | MN | Mongolia | UZ | Uzbekistan |
| ES | Spain | | | VN | Viet Nam |
| FI | Finland | | | | |

- 1 -

NON-CONTACTING TRANSACTION SYSTEM FOR TICKETING

The present invention relates to apparatus for logging data of transactions and particularly, but not exclusively, the invention relates to apparatus for conducting cashless financial transactions.

It is now widely accepted that purchasing goods or services in the domestic sector is more efficiently carried out if the purchase transaction does not use cash. Cash is often perceived as, at best, cumbersome and, at worst, an unnecessary risk to personal safety, for example, from muggings and also financially, from theft. Current trends are to move towards a "cashless society" and the momentum of this trend is gaining in support nationally and internationally.

Credit cards fall short of meeting all requirements in cashless transactions. For example, as regards security, a credit card contains the owner's identity number imprinted on a magnetic strip on the back of the card, together with the owner's name embossed on the front of the card. A holograph of the owner's signature is written on the back of the card and is the only means of confirming the correct ownership of the card.

Nevertheless, the present type of credit card has severe limitations in providing the ideal solution for a cashless transaction. For such a transaction to commence, the credit card must physically come into

- 2 -

contact with either a paper voucher on which the embossed details are transferred by carbon copy or the card must be physically passed through a swipe machine so that the magnetic strip is electro-magnetically read by a magnetic head. Both of these techniques require intimate physical contact of a machine with a credit card. The next step in the transaction is for the owner of the credit card to append his signature on the paper voucher. The vendor in the transaction compares, or should compare, the signature on the back of the card with that on the voucher. Assuming that there is a fair degree of resemblance between the signatures, the vendor then accepts that the transaction is complete. In order for the card owner's account to be debited, the vendor either sends copies of the carbon slips to the credit card company or the information from the magnetic swipe reader is electronically stored and usually transmitted over a telephone link. In the former case, one of the problems is loss of credit card slips or even damage to the slips such as to render details of the credit card unusable, with the result that the owner's account does not get debited and this results in a loss to the vendor. In the case of a card swipe machine, the information is periodically scanned from a central computer which polls all the swipe machines to which it is linked and the details of the transaction are then fed to a central storage location where the information is then entered

- 3 -

into the user's account and a bill is then prepared and sent to the user.

One problem with the existing system is that card fraud is very easily perpetrated. This is mainly because the signature appears on the reverse side of the card. A signature can generally be perfected by repeated copying so that the end result appears similar to that on the card. The unauthorised user of the card can then forge the signature to complete a fraudulent transaction. Even if a stolen or lost card is reported, there is often considerable time before all premises and businesses accepting that type of card are notified. In the case of a swipe card, notification is carried out remotely and periodically over the telephone line. Nevertheless, a professional criminal is able to verify whether the card is still valid with minimal risk and to use the card on a day-to-day basis with minimal risk of being apprehended.

A further disadvantage of existing credit card systems is that it is not possible to use the card without physical contact. Therefore, it is not presently feasible to use a credit card for conducting a low value transaction, such as purchasing a ticket for the parking of a car or admission to a sports function, admission to a metro or any other public transportation system, and in such situations, cash is still the preferred method of payment.

An object of the present invention is to obviate or

- 4 -

mitigate at least one of the aforementioned disadvantages.

This is achieved by providing a hand-held transmitter which contains information unique to the user and which, when actuated by the user, generates a wireless signal which is picked up by a receiver. In a preferred arrangement, the transmitter contains the user's code and has a keypad for the user to insert a personal identification number (PIN) code. This PIN might be a series of digits or the owners telephone number, car registration number or any code proffered by the owner. The detectors of the receiver are coupled via a transmission line to a local system where the user's code and PIN number and details of the purchase, received from the vendor, are registered against the user's number so that billing can be carried out subsequently.

The local system can include a means for checking and for rectifying the correctness of the code and PIN number prior to transmitting the data via the modem to the central system. The device is flexible and the PIN number could be required for all transactions to minimise fraud. Each transmitter may be provided with a terminal to allow an input to the memory for changing details of the user's account and charge number. To prove ownership of the transmitter, the owner's name, telephone number, car registration number etc. may also be fused in the memory along with the credit card number. In the case where there is doubt in the ownership of the transmitter,

- 5 -

the vendor might ask the person who was using the transmitter to identify himself by either name, PIN, telephone number or car registration as proof of identity.

An object of the present invention is to obviate or mitigate at least one of the aforementioned disadvantages.

According to one aspect of the present invention, there is provided a non-contacting transaction system comprising,

transmitter means having a memory for storage of data identifying the user therein, and a transmitter for transmitting the stored data to a remote location upon actuation of the transmitter means by the user, and

receiver means for receiving the transmitted data and also having indicator means for indicating that the data transmitted is received and that the transaction can proceed.

Preferably, the transmitter means includes a keypad for the user to insert details of a PIN number.

Conveniently, the non-contacting transaction system is a car-park ticketing system.

The transmitter includes a switch actuatable by the user which results in the stored data being continually transmitted or transmitted in bursts during the transmitting actuation.

Conveniently, the receiver or local system may be coupled by a modem or the like over the telephone network to a central data processing and storage unit where

- 6 -

details of the transactions are allocated to the user's account for subsequent billing.

Alternatively, the local system may include disk storage means or other suitable mass storage means for storing validated transactions for subsequent despatching of the stored transaction data to the central data processing and storage unit at a later date.

Conveniently, the receiver includes a display for displaying to the vendee his PIN in the transmitted information. Advantageously, the receiver includes parity and code check means for rectifying the correctness of the received code prior to transmitting it to the modem.

According to another aspect of the invention, there is provided a transmitter for use in a non-contacting transaction system, said transmitter comprising a memory for storing data identifying the user, a transmitter coupled to the memory for wireless transmission of said stored data to a remote location, and switch means actuatable by the user for causing said stored data to be transmitted.

Preferably, the transmitter includes a keypad for the user to insert details of a personal identification number (PIN), and said data being transmitted only if the correct PIN number is keyed in.

Preferably also, the transmitter includes a plurality of keys representative of different user accounts and the user can nominate which account a transaction is to be

- 7 -

attributed to by selecting the appropriate key.

The transmitter is an infra-red transmitter.

Alternatively, the transmitter may include a remote telephone console interfaced to said memory and keys whereby a user may remotely conduct a transaction using radio frequency communications or any part of the electro-magnetic spectrum for communications.

According to a further aspect of the invention, there is provided a receiver for use in a non-contacting transaction system, said receiver comprising a data receiver for receiving a wireless transmission, means for indicating that the data has been received, means for processing the received data for display, means for verifying the correctness of the data received, and display means for displaying to a vendor details of the user stored in said transmitter.

Preferably, the receiver is a car-park ticketing machine.

Preferably, the local system is coupled to the elements which combined comprise a card swipe machine. Conveniently, the receiver and/or card swipe machine are coupled to a cellular telephone network for receiving said data by radio frequency communication. Conveniently, the receiver may be coupled by a modem or the like over the telephone network to a central data processing and storage unit where details of the transactions are allocated to the user's account for subsequent billing.

Alternatively, the receiver may include disk storage means, or random access memory (RAM) or other suitable storage means for storing validated transactions for subsequent despatching of the stored transaction data to the central data processing and storage unit at a later date.

Thus, the invention provides a considerable improvement over existing cash cards to satisfy requirements for cashless transactions. The invention permits cashless transactions to be performed in a non-contacting fashion.

These and other aspects of the present invention will become apparent from the following description when taken in combination with the accompanying drawings in which:-

Fig. 1 is a diagrammatic view of a system consisting of a transmitter and a receiver shown coupled to a car-park ticketing machine in accordance with one aspect of the present invention;

Fig. 2 is a diagrammatic view of an alternative transmitter similar to that shown in Fig. 1 and which includes a keyboard and a set of credit card select buttons;

Fig. 3a and 3b are schematic block diagrams of the transmitter and receiver, respectively shown in Fig. 1;

Fig. 4 is a schematic block diagram of the transmitter shown in Fig. 2;

Fig 5 is a schematic block diagram of an alternative

- 9 -

transmitter similar to that of Figs. 1 and 2, but which has no keypad;

Fig. 6 depicts a flow chart of the operation of the transmitter and receiver conducted by a user in the pursuit of purchasing a ticket using the transmitter and receiver shown in Fig. 1;

Fig. 7 and Fig. 8 depict flow charts which are similar to Fig. 6, but using the transmitters of Fig 2 and Fig. 3 respectively, and

Fig. 9 is a circuit diagram of an embodiment of an infra-red transmitter in accordance with the present invention.

Reference is first made to Fig. 1 of the drawings which depicts a hand-held transmitter 10 and receiver 12 in accordance with the first embodiment of the invention. As will be later described in detail, the transmitter 10, when actuated, transmits information about the user which is received by the receiver 12 and used to initiate the transaction. The transmitter is about 10cm long and has a clip 13 for securing in a pocket or the like. The transmitter has a switch 16 and an infra-red filter 18 at one end of the transmitter. The transmitter also has a keypad 17 which enables high value transactions to be carried out by combining the stored credit card or account number with a personal identification number (PIN).

Reference is also made to Fig. 3a, 3b and Fig. 6 of the drawings which are a schematic block diagram of the

- 10 -

transmitter and receiver circuits and a flow chart of the operations involved in a transaction using the transmitter/receiver arrangement of Fig. 1. The transmitter 10 contains a programmable read only memory (PROM) chip 20 in which the owner's personal credit number (i.e. similar to a credit card number or bank number etc.) is electronically stored. The owner's name or other identifying number such as vehicle registration number or community charge number, is also stored. When the switch 16 is depressed, power is applied to the circuit from the battery 22 and the information contained in the PROM 20 is only transferred in parallel using the clock 24, to the shift register 26 only if the correct PIN number is inserted via the keypad 17. The keyed-in PIN number is compared in comparator 27 with the fused PIN number, and only if they match is the information transferred to shift register 26. The identity part of the fused data, for example, the vendee's name or community charge number or driving licence number, can be checked as previously mentioned. This further improves the security as the PIN number is known only to the user and will provide at least the same level of security as with a bank charge card for use with High Street terminals and the like. the information received in the shift register 26 is then transferred to the infra-red transmitter 28, in serial form, and clocked by the clock 24 for transmission. The infra-red filter 18 is a notch filter selected to best

- 11 -

suit infra-red transmission.

Thus, in practice, the vendee or user can transfer his personal credit details in a non-contacting, remote fashion in the infra-red waveband. Of course, it will be appreciated that transmission might be in any suitable part of the electro-magnetic spectrum, not necessarily at infra-red wavelengths.

The transmitted data is received by the receiver 12 which is coupled to a conventional car-park ticketing machine 30 by an internal cable and connector 32,34 respectively. As best seen from the receiver schematic block diagram in Fig. 3b, the data is received by a suitable infra-red receiver 36 in serial form and the receiver then assembles the data into parallel format for the shift register 38. The parallel data is checked for parity in the code corrector 40 and any precoded format of data using a protocol circuit 42 prior to being transferred to the ticketing machine 30.

Thus, the information in the transmitter is passed from the transmitter to the receiver and then to the ticketing machine without contact or from suffering from the aforementioned disadvantages.

The operation of the system in a cashless transaction is best described with reference to the flow chart shown in Fig. 6 of the drawings. The receiver 12 on the ticketing machine has a display panel 44 which displays the contents of the identity part of the message, for

- 12 -

example, the name of the user or vendee once the transmission is complete. This vendee can check that transmission has occurred and all validity checks made by reading the contents of display panel 44, as shown in step 4 of Fig. 6. Assuming that the vendee is the owner of the transmitter, only he knows the detail of the identity part of the message and knows the correct code to key in. If, in fact, the vendee is not the owner of the transmitter, then only access to sophisticated electronic equipment would be required to interrogate the transmitter to enable misuse of the transmitter. Although this is, in theory, possible it is most unlikely that this facility would be available to criminals to carry out widespread fraud and the security achieved is far superior to that of comparing signatures.

Reference is now made to Figs, 2, 4 and 7 of the accompanying drawings which describe a further embodiment of the invention. The transmitter 10a shown in Fig. 2 is similar to that shown in Fig. 1 in which like numerals denote like parts, but with the suffix 'a' added and which includes a facility for using the transmitter 10a with more than one credit card. This is achieved by providing a set of card select buttons 50, each of which can be selected by the user (step 2a, Fig. 7) in order to designate a particular transaction to a particular credit card. In this case, the individual owns several credit cards and wishes to have one transmitter to operate on

- 13 -

behalf of all of the credit cards. Each card select button allows the operator to select the credit card which he wishes to use to complete the transaction. As shown in Fig. 4, the switches 50 are coupled to the PROM 20a and to the other components which contain the details appropriate to the card selected. Once the particular button has been depressed, the operation of the device is identical to that described with reference to Fig. 1.

The device can be used for low value transactions such as paying parking charges, ticketing for metros and the like and as security codes are regularly updated any loss and unauthorised use is likely to be insignificant. Moreover, the transaction is likely to be fully mechanised for the vendor. Reference is now made to Fig. 5 of the accompanying drawings which are for a transmitter of generally similar size and shape to the transmitter 10 shown in Fig. 1 except that it does not have a key-pad. The circuit elements in Fig. 5 are referred to by like numerals, but by suffix 'b' added and operate in the same way. From Fig. 5 it will be seen that the basic operation is similar to the transmitter of Fig. 1 except that a PIN number is not employed. Moreover, the transmitted word would be a unique number and correlated to the user's identity by the software contained in the receiving apparatus. An example of how this circuit might be implemented is shown in Fig. 9. It comprises electronic elements where each and every one form part of

- 14 -

the industry standard. ICs 1A and B might be a 74ALS14 or any suitable package containing 6 Schmitt trigger invertors; IC 2 is a 22V10 or any similar Programmable Array Logic configured to drive IC 3, an NMC9306, a 512-bit programmable serial read only memory. The resistors and capacitors are 1/4 watt, 5 percent tolerance components; a nominal 6 volt battery is employed. The light emitting diode D1 is similar to those used in television channel changers. The user's credit card number and the encryption element are fused in IC 3. These data are configured in an auto-clocking code, a 3 from 9 code being an example, ready for transmission. Implementation might also employ micro-processors/micro-controllers to reduce the component count within the transmitter. There are many such devices available, an example being COP8720C, or a COP424C with an accompanying NMC9306.

The receiver might be configured round a bar-code reader. One example is the Hewlett-Packard HBCR8500 which contains all the necessary electronics to convert the data from the transmitter to ASCII, an international standard compatible with the majority of peripherals and swipe card machines.

Reference is now made to Figs. 5 and 8 of the accompanying drawings which are for a transmitter generally similar in size and shape to the transmitter 10 shown in Fig. 1 except that it does not have a keypad.

- 15 -

The circuit elements in Fig. 5 are referred to by like numerals, but with the suffix 'b' added and operate in the same way. From Figs. 5 and 8 it will be seen that the basic operation is similar to the transmitter of Fig. 1 except that a PIN number is not entered, that is, step 3 is omitted. This device can be used for low value transactions such as paying parking charges, paying tolls and the like and as the security codes are regularly updated any loss and unauthorised use is likely to be insignificant.

It will be appreciated that various modifications may be made to the embodiments hereinbefore described without departing from the scope of the invention. For example, two chips may be combined in a transmitter; one chip containing the user's credit information, PIN number and the like, and a second chip containing an encryption algorithm so that the data transmitted is encrypted for more secure communications. Each receiver would have a corresponding chip with a decryption algorithm so that the transmitted information can be decoded and validation completed by the local system. The size and shape of the transmitter may be varied and, in fact, depending on manufacturing technology, the transmitter may be credit card shaped to fit in a wallet or the like. The transmitter on such a credit card shape could also contain a keycard and credit card selector keys. The device and system could be used other than for financial

- 16 -

transactions; it could be used to control entry or access to secure areas and the like, with the user's code (PIN) being verified at a local or central location.

The communication medium could be radio frequency (r.f.) sound or ultrasound suitable for carrying the necessary information to initiate a transaction, although it is believed that infra-red is the most suitable. A further modification is the addition of r.f. circuits to the transmitter and receiver so that the user is able to complete transactions remotely, in a similar manner to the operation of cardless cellular telephones. Thus, cinema theatre tickets and the like, could be ordered using the transmitter, and shopping could be done remotely with the receiver processing the order and automatically debiting the user's account.

The principal advantage of the invention is that it improves the security of cashless transactions and allows the transactions to be completed in a non-contacting fashion. Furthermore, it provides a more secure method of checking identity of the user without requiring signatures. In addition, a single transmitter can be used to complete transactions for various cards and the transactions can be performed for purchasing any type of goods or service, parking tickets, paying tolls and the like which is not hitherto been possible with existing credit cards.

CLAIMS

1. A non-contacting transaction system comprising,
transmitter means having a memory for storage of data identifying the user therein, and a transmitter for transmitting the stored data to a remote location upon actuation of the transmitter means by the user, and
receiver means for receiving the transmitted data and also having indicator means for indicating that the data transmitted is received and that the transaction can proceed.
2. A system as claimed in claim 1 wherein the transmitter means includes a keypad for the user to insert details of a PIN number.
3. A system as claimed in claim 1 or claim 2 wherein the non-contacting transaction system is a car-park ticketing system.
4. A system as claimed in any preceding claim wherein the transmitter includes a switch actuatable by the user which results in the stored data being continually transmitted or transmitted in bursts during the transmitting actuation.
5. A system as claimed in any preceding claim wherein the receiver or local system is coupled to a modem or the like over the telephone network to a central data processing and storage unit where details of the transactions are allocated to the user's account for

- 18 -

subsequent billing.

6. A system as claimed in any one of claims 1 to 4 wherein the receiver or local system includes disk storage means or other suitable mass storage means for storing validated transactions for subsequent despatching of the stored transaction data to the central data processing and storage unit at a later date.

7. A system as claimed in any preceding claim wherein said receiver means includes a display for displaying to the vendee his PIN in the transmitted information.

8. A system as claimed in any preceding claim wherein said the receiver means includes parity and code check means for rectifying the correctness of the received code prior to passing it to the modem.

9. A transmitter for use in a non-contacting transaction system, said transmitter comprising a memory for storing data identifying the user, a transmitter coupled to the memory for wireless transmission of said stored data to a remote location, and switch means actuatable by the user for causing said stored data to be transmitted.

10. A transmitter as claimed in claim 9 wherein the transmitter includes a keypad for the user to insert details of a personal identification number (PIN), and said data being transmitted only if the correct PIN number is keyed in.

11. A transmitter as claimed in claim 10 wherein the transmitter includes a plurality of keys representative of

- 19 -

different user accounts and the user can nominate which account a transaction is to be attributed to by selecting the appropriate key.

12. A transmitter as claimed in claim 9, 10 or 11 wherein the transmitter is an infra-red transmitter.

13. A transmitter as claimed in claim 9, 10 or 11 wherein the transmitter includes a remote telephone console interfaced to said memory and keys to enable a user to remotely conduct a transaction using radio frequency communications or any part of the electro-magnetic spectrum for communications.

14. A receiver for use in a non-contacting transaction system, said receiver comprising a data receiver for receiving a wireless transmission, means for indicating that the data has been received, means for processing the received data for display, means for verifying the correctness of the data received, and display means for displaying to a vendor details of the user stored in said transmitter.

15. A receiver as claimed in claim 14 wherein the receiver is a car-park ticketing machine.

16. A receiver as claimed in claim 14 or claim 15 wherein the non-contacting transaction system is coupled to the elements which combined comprise a card swipe machine.

17. A receiver as claimed in claim 16 wherein the receiver and/or card swipe machine are coupled to a cellular telephone network for receiving said data by

- 20 -

radio frequency communication.

18. A receiver as claimed in any preceding claim wherein the receiver is coupled by a modem or the like over the telephone network to a central data processing and storage unit where details of the transactions are allocated to the user's account for subsequent billing.

19. A receiver as claimed in one of claims 15 to 17 wherein the receiver includes disk storage means, or random access memory (RAM) or other suitable storage means for storing validated transactions for subsequent despatching of the stored transaction data to the central data processing and storage unit at a later date.

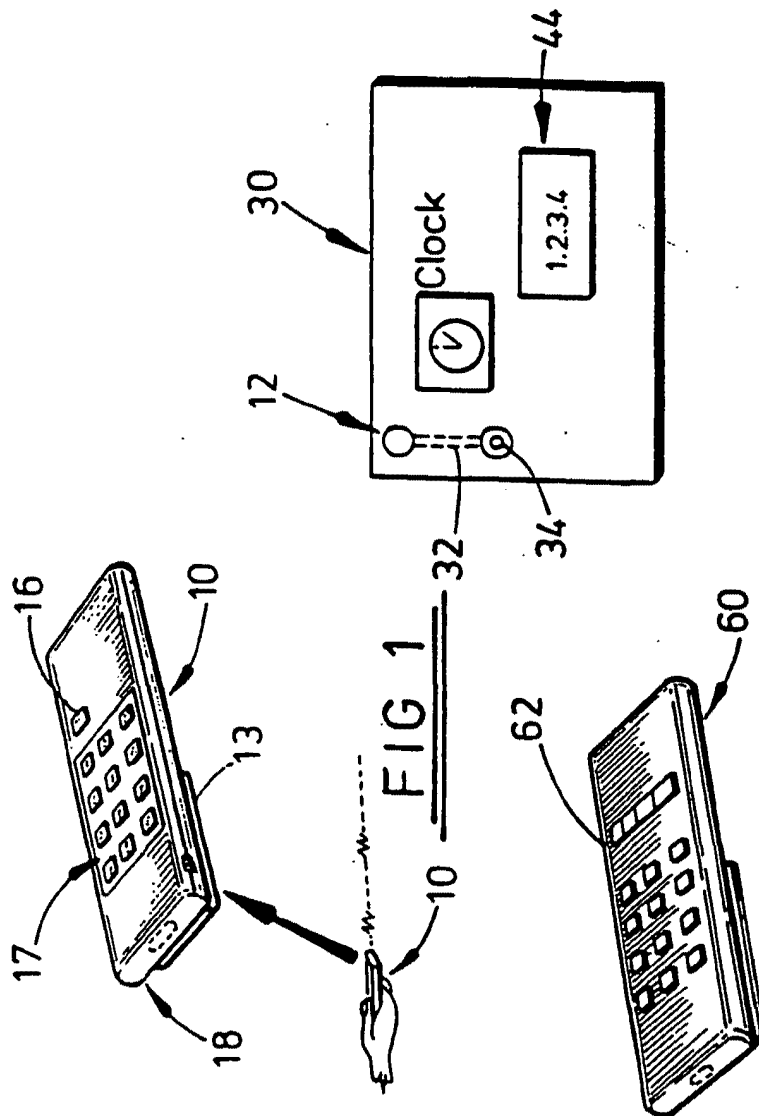

FIG 1

FIG. 2

SUBSTITUTE SHEET

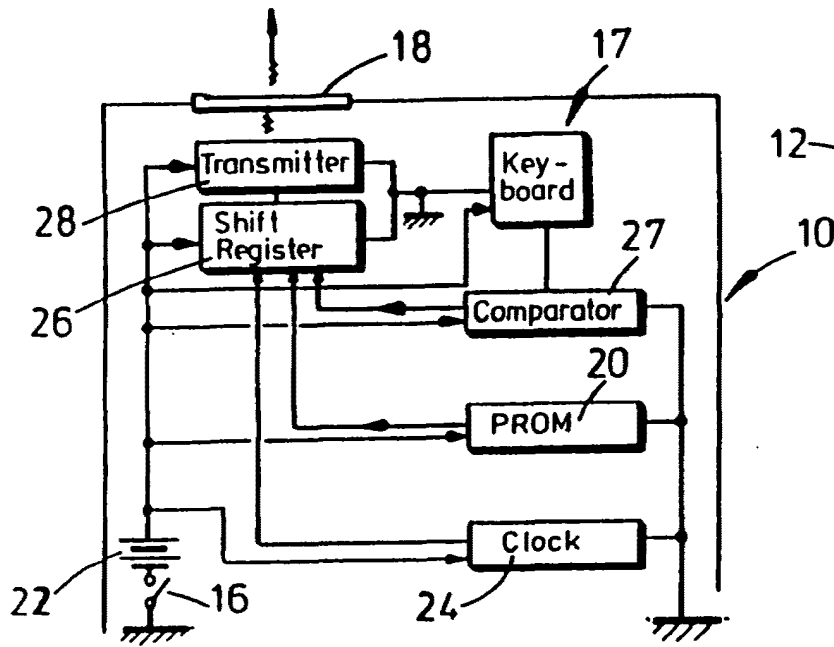

FIG. 3a

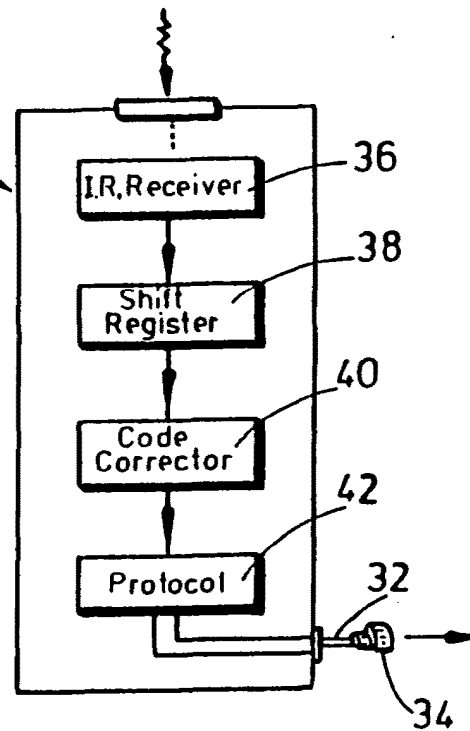

FIG 3b

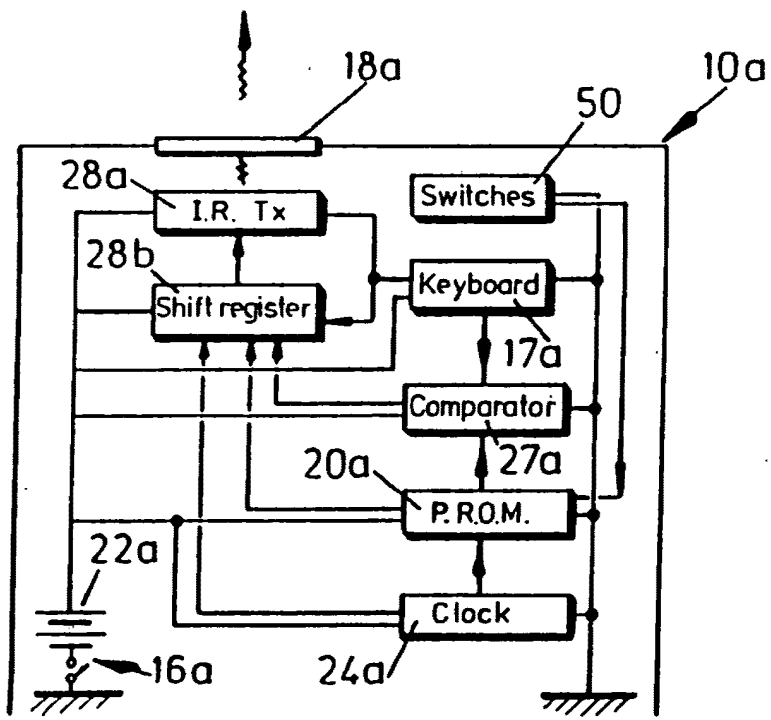

FIG. 4

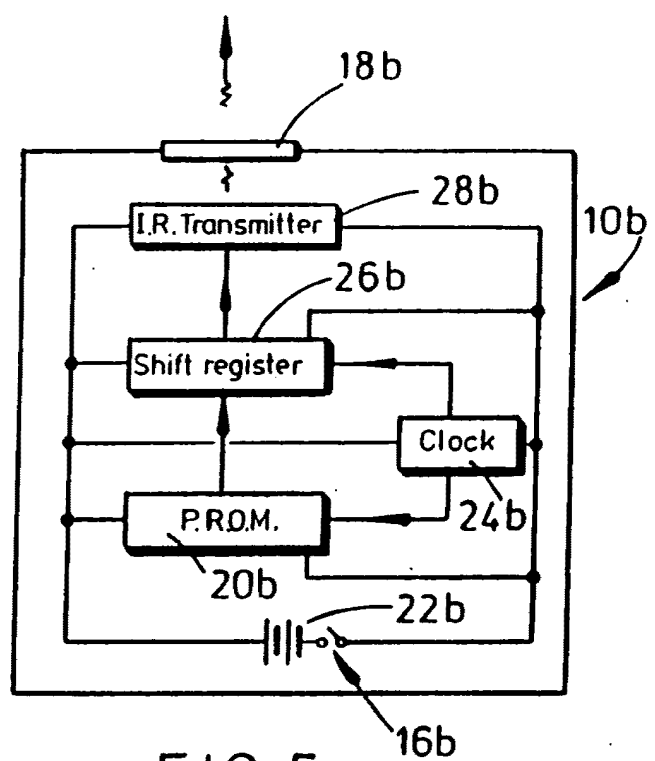

FIG. 5

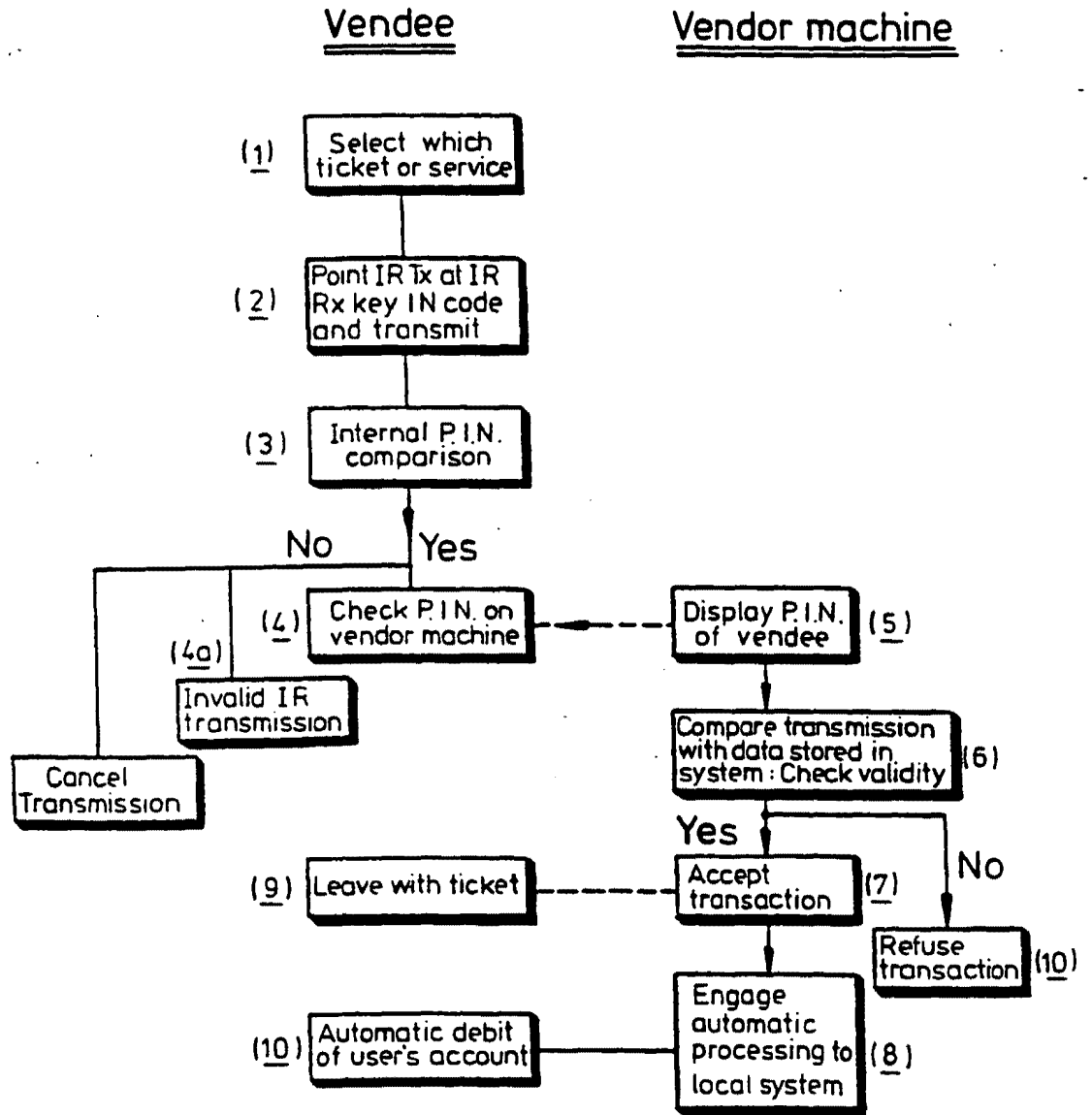

FIG. 6

Vendee

Vendor machine

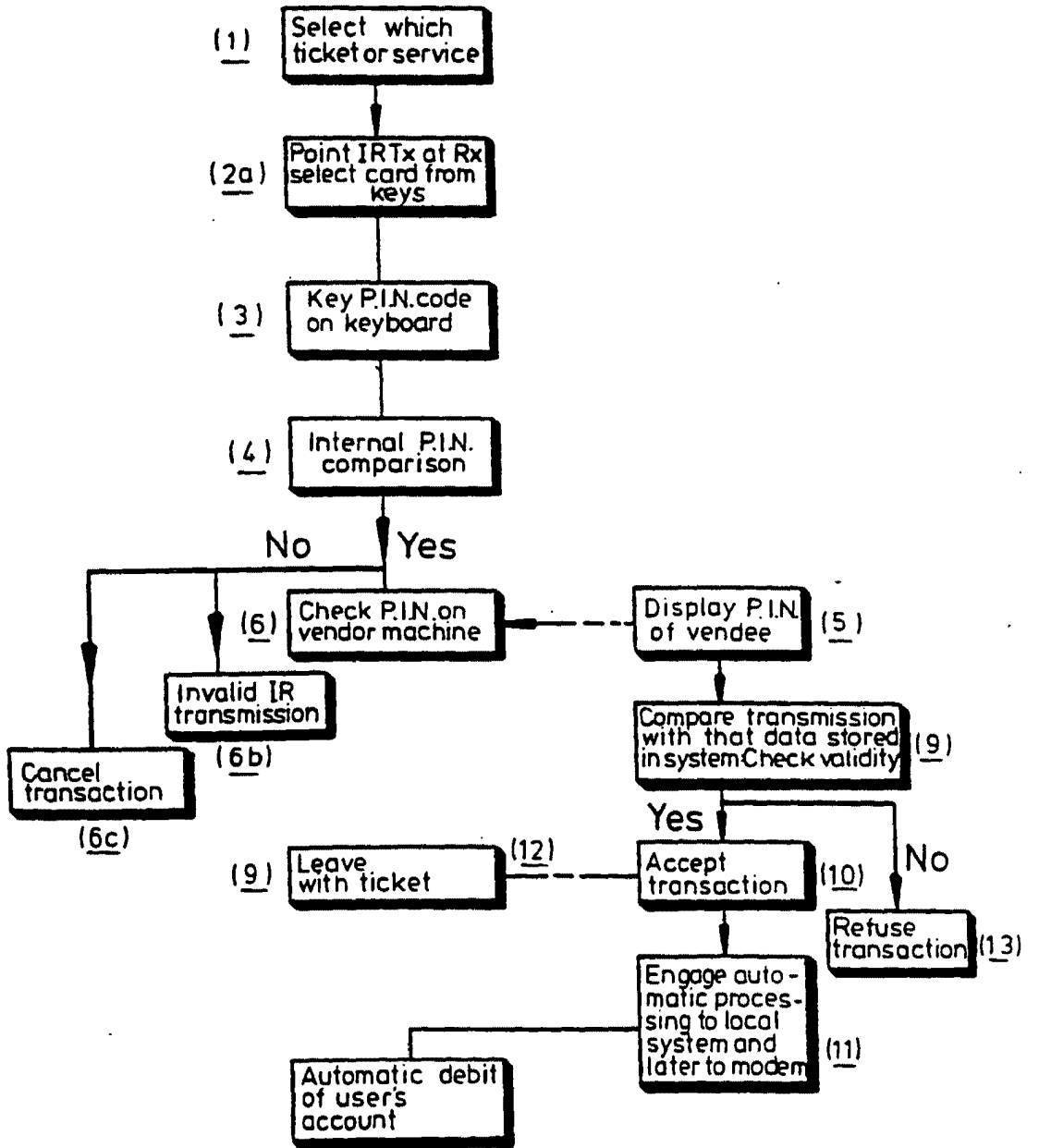

FIG. 7

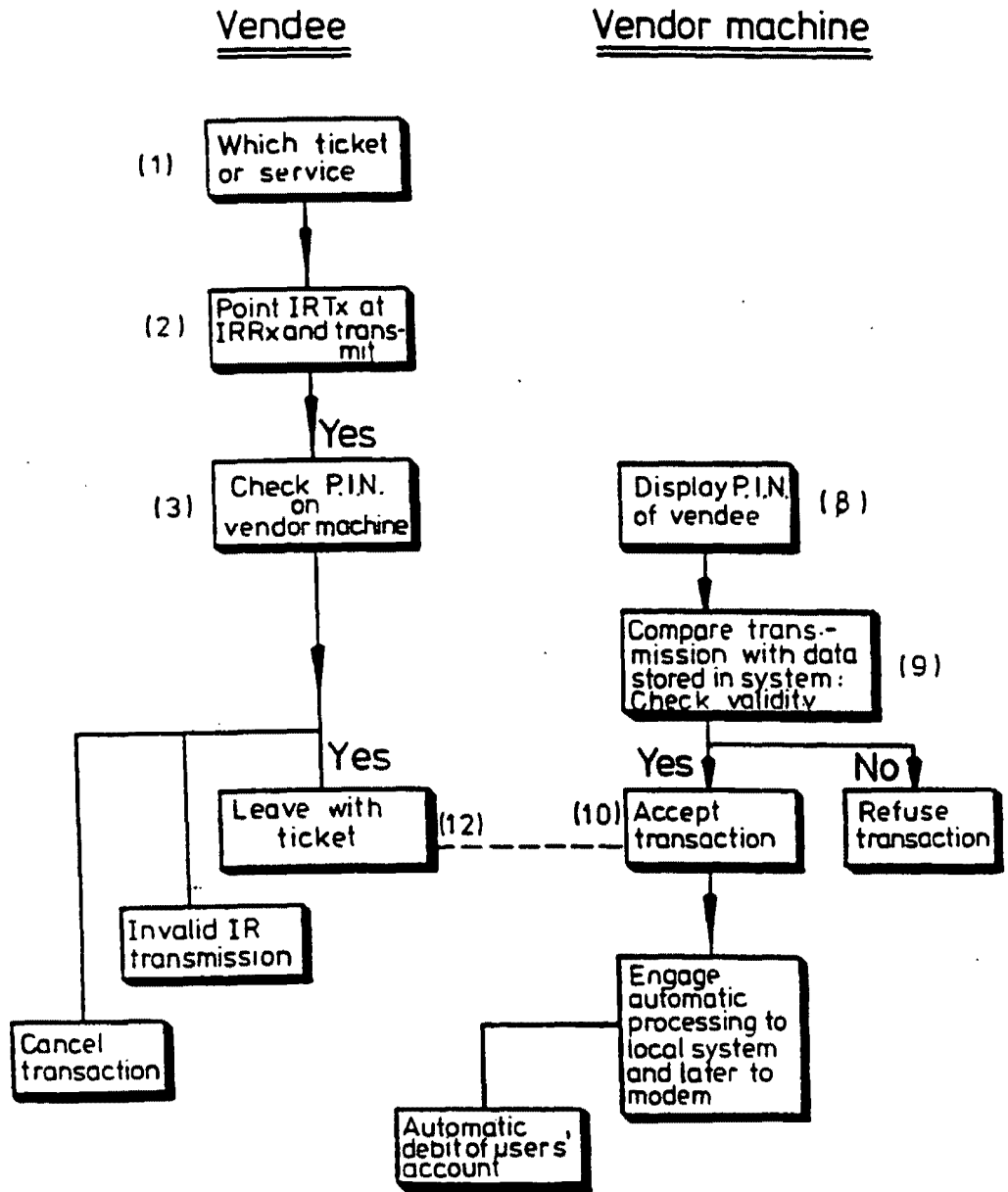

FIG. 8

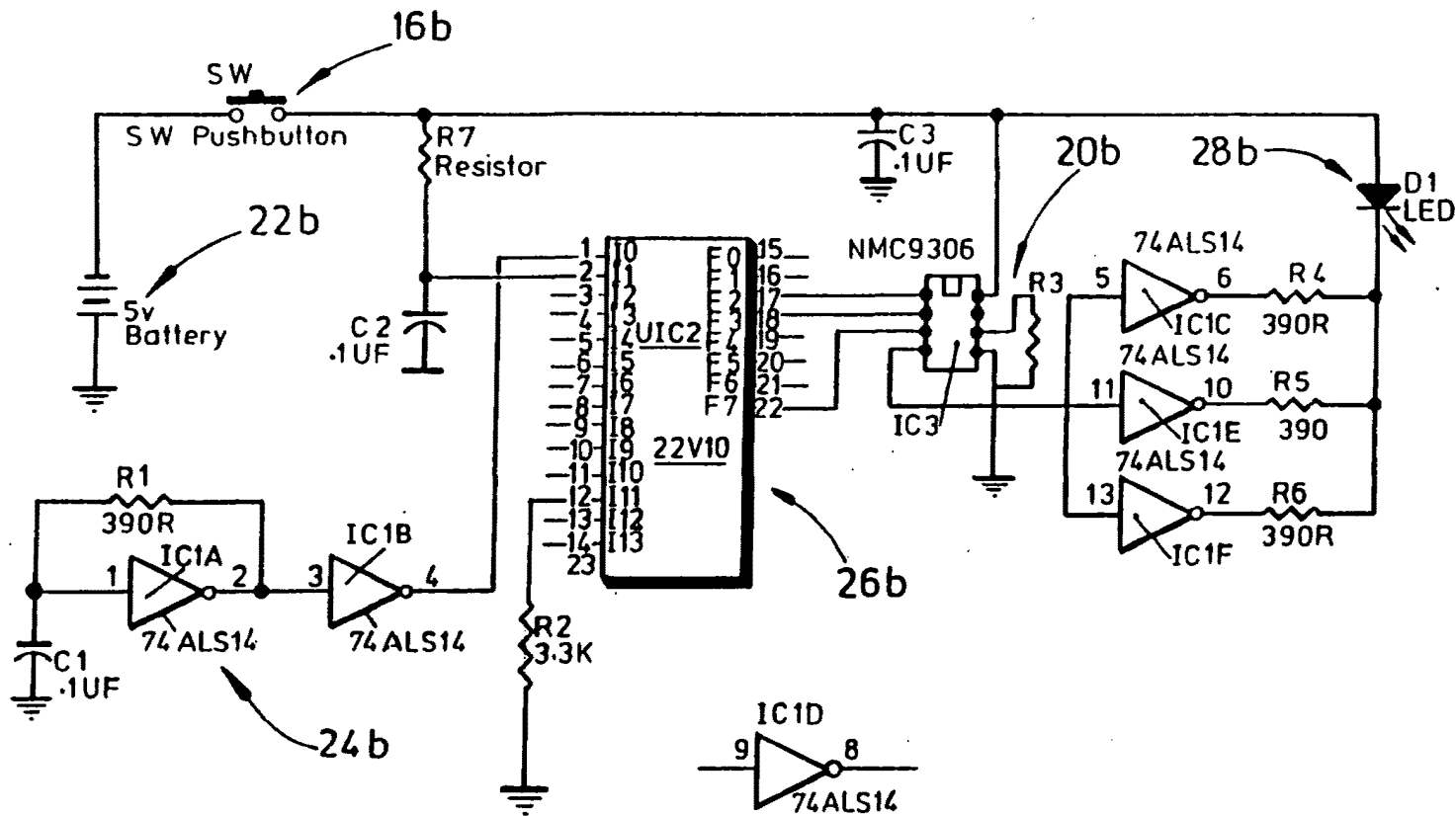

FIG. 9

INTERNATIONAL SEARCH REPORT

International Application No

PCT/GB 93/01526

| | | |
|--|---|---|
| I. CLASSIFICATION OF SUBJECT MATTER (if several classification symbols apply, indicate all) ⁶ | | |
| According to International Patent Classification (IPC) or to both National Classification and IPC Int.Cl. 5 G06K7/00; G06K17/00 | | |
| II. FIELDS SEARCHED | | |
| Minimum Documentation Searched ⁷ | | |
| Classification System | Classification Symbols | |
| Int.Cl. 5 | G06K | |
| Documentation Searched other than Minimum Documentation to the Extent that such Documents are Included in the Fields Searched ⁸ | | |
| | | |
| III. DOCUMENTS CONSIDERED TO BE RELEVANT⁹ | | |
| Category ¹⁰ | Citation of Document, ¹¹ with indication, where appropriate, of the relevant passages ¹² | Relevant to Claim No. ¹³ |
| X | US,A,4 277 837 (STUCKERT,P.E) 7 July 1981 see column 1, line 51 - line 61 see column 1, line 66 - line 68 see column 2, line 1 - line 3 see column 3, line 12 - line 16 see column 3, line 28 - line 32 see column 9, line 65 - line 68 see column 10, line 1 - line 11 see column 14, line 67 - line 68 see column 15, line 1 - line 12 see claim 1 | 1,2,5, 8-10,13, 18 |
| A | --- | -/-- 15 |
| <p>¹⁰ Special categories of cited documents : ^{"A"} document defining the general state of the art which is not considered to be of particular relevance ^{"E"} earlier document but published on or after the international filing date ^{"L"} document which may throw doubts on priority claim(s) or which is cited to establish the publication date of another citation or other special reason (as specified) ^{"O"} document referring to an oral disclosure, use, exhibition or other means ^{"P"} document published prior to the international filing date but later than the priority date claimed</p> <p>^{"T"} later document published after the international filing date or priority date and not in conflict with the application but cited to understand the principle or theory underlying the invention ^{"X"} document of particular relevance; the claimed invention cannot be considered novel or cannot be considered to involve an inventive step ^{"Y"} document of particular relevance; the claimed invention cannot be considered to involve an inventive step when the document is combined with one or more other such documents, such combination being obvious to a person skilled in the art. ^{"A"} document member of the same patent family</p> | | |
| IV. CERTIFICATION | | |
| Date of the Actual Completion of the International Search 05 OCTOBER 1993 | | Date of Mailing of this International Search Report 12. 10. 93 |
| International Searching Authority EUROPEAN PATENT OFFICE | | Signature of Authorized Officer HERSKOVIC M. |

| III. DOCUMENTS CONSIDERED TO BE RELEVANT (CONTINUED FROM THE SECOND SHEET) | | |
|--|--|--------------------------|
| Category * | Citation of Document, with indication, where appropriate, of the relevant passages | Relevant to Claim No. |
| X | WO,A,8 603 869 (NCR CORP.) 3 July 1986 see page 1 see page 6 see page 7 see claims 1,2,4,7,8 --- | 1,2,5, 9-12,14, 18 |
| A | US,A,4 800 543 (LYNDON-JAMES,R. ET AL) 24 January 1989 see the whole document --- | 1,2,4, 11,12,14 |
| A | US,A,4 639 583 (ZEROWIN,J.H.) 27 January 1987 see the whole document ----- | 6,19 |

**ANNEX TO THE INTERNATIONAL SEARCH REPORT
ON INTERNATIONAL PATENT APPLICATION NO.**

GB 9301526
SA 77021

This annex lists the patent family members relating to the patent documents cited in the above-mentioned international search report. The members are as contained in the European Patent Office EDP file on
The European Patent Office is in no way liable for these particulars which are merely given for the purpose of information. 05/10/93

| Patent document cited in search report | Publication date | Patent family member(s) | Publication date |
|--|------------------|-------------------------|------------------|
| US-A-4277837 | 07-07-81 | CA-A- 1111567 | 27-10-81 |
| | | DE-A, C 2852941 | 05-07-79 |
| | | FR-A, B 2413721 | 27-07-79 |
| | | GB-A, B 2011671 | 11-07-79 |
| | | JP-C- 1220759 | 26-07-84 |
| | | JP-A- 54094855 | 26-07-79 |
| | | JP-B- 58053784 | 01-12-83 |
| | | NL-A- 7812390 | 03-07-79 |
| | | SE-A- 7812924 | 01-07-79 |
| WO-A-8603869 | 03-07-86 | US-A- 4634845 | 06-01-87 |
| | | US-A- 4689478 | 25-08-87 |
| | | CA-A- 1240068 | 02-08-88 |
| | | EP-A, B 0207125 | 07-01-87 |
| | | JP-T- 62501239 | 14-05-87 |
| | | CA-A, C 1253626 | 02-05-89 |
| US-A-4800543 | 24-01-89 | AU-A- 2645188 | 08-06-89 |
| | | EP-A- 0319297 | 07-06-89 |
| | | JP-A- 2002974 | 08-01-90 |
| US-A-4639583 | 27-01-87 | None | |

EPO FORM P0119

For more details about this annex : see Official Journal of the European Patent Office, No. 12/82

PCT

WORLD INTELLECTUAL PROPERTY ORGANIZATION
International Bureau



INTERNATIONAL APPLICATION PUBLISHED UNDER THE PATENT COOPERATION TREATY (PCT)

| | | |
|--|--|--|
| (51) International Patent Classification ⁶ : H04L | A2 | (11) International Publication Number: WO 97/21291 |
| | | (43) International Publication Date: 12 June 1997 (12.06.97) |
| (21) International Application Number: PCT/CA96/00794 (22) International Filing Date: 2 December 1996 (02.12.96) (30) Priority Data: 2,164,231 1 December 1995 (01.12.95) CA (71)(72) Applicant and Inventor: POCOCK, Michael [CA/CA]; 485 Queens Avenue, London, Ontario N6B 1Y3 (CA). | (81) Designated States: AU, BR, JP, MX, US, Eurasian patent (AM, AZ, BY, KG, KZ, MD, RU, TJ, TM), European patent (AT, BE, CH, DE, DK, ES, FI, FR, GB, GR, IE, IT, LU, MC, NL, PT, SE). Published Without international search report and to be republished upon receipt of that report. | |

(54) Title: A SYSTEM FOR ON-DEMAND REMOTE ACCESS TO A SELF-GENERATING AUDIO RECORDING, STORAGE, INDEXING AND TRANSACTION SYSTEM

(57) Abstract

The system allows radio broadcast listeners to use a telephone to connect to a database that contains prerecorded audio descriptions (e.g. spoken text and/or music) of material played by the radio station. The database is indexed by the radio station's program schedule or play-list to allow the user to select a particular audio description of interest (e.g. the song currently airing, the song last played, etc.). Hearing the audio description over the telephone ensures the listener that the requested selection is in fact correct. By using the telephone DTMF touch tone controls, the listener can place an order to purchase the selected material over the telephone.

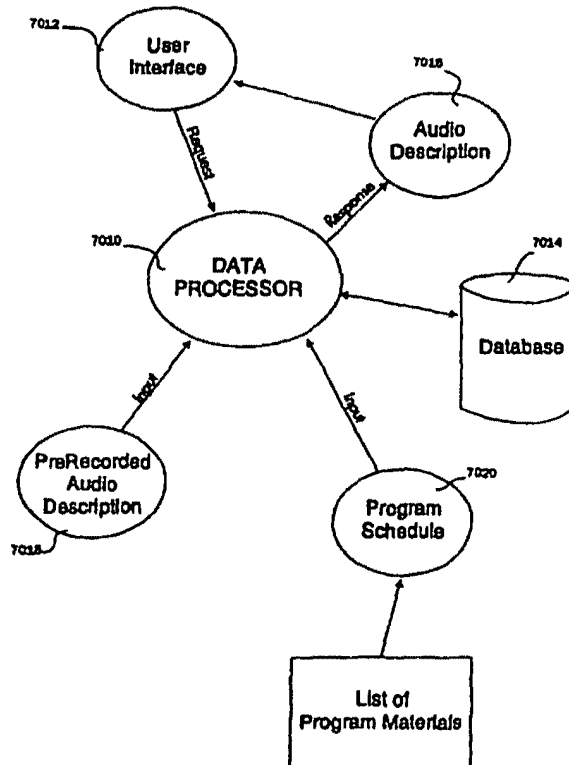

FOR THE PURPOSES OF INFORMATION ONLY

Codes used to identify States party to the PCT on the front pages of pamphlets publishing international applications under the PCT.

| | | | | | |
|----|--------------------------|----|--|----|--------------------------|
| AM | Armenia | GB | United Kingdom | MW | Malawi |
| AT | Austria | GE | Georgia | MX | Mexico |
| AU | Australia | GN | Guinea | NE | Niger |
| BB | Barbados | GR | Greece | NL | Netherlands |
| BE | Belgium | HU | Hungary | NO | Norway |
| BF | Burkina Faso | IE | Ireland | NZ | New Zealand |
| BG | Bulgaria | IT | Italy | PL | Poland |
| BJ | Benin | JP | Japan | PT | Portugal |
| BR | Brazil | KE | Kenya | RO | Romania |
| BY | Belarus | KC | Kyrgyzstan | RU | Russian Federation |
| CA | Canada | KP | Democratic People's Republic of Korea | SD | Sudan |
| CF | Central African Republic | KR | Republic of Korea | SE | Sweden |
| CG | Congo | KZ | Kazakhstan | SG | Singapore |
| CH | Switzerland | LJ | Liechtenstein | SI | Slovenia |
| CI | Côte d'Ivoire | LK | Sri Lanka | SK | Slovakia |
| CM | Cameroon | LR | Liberia | SN | Senegal |
| CN | China | LT | Lithuania | SZ | Swaziland |
| CS | Czechoslovakia | LU | Luxembourg | TD | Chad |
| CZ | Czech Republic | LV | Latvia | TG | Togo |
| DE | Germany | MC | Monaco | TJ | Tajikistan |
| DK | Denmark | MD | Republic of Moldova | TT | Trinidad and Tobago |
| EE | Estonia | MG | Madagascar | UA | Ukraine |
| ES | Spain | ML | Mali | UG | Uganda |
| FI | Finland | MN | Mongolia | US | United States of America |
| FR | France | MR | Mauritania | UZ | Uzbekistan |
| GA | Gabon | | | VN | Viet Nam |

A SYSTEM FOR ON-DEMAND REMOTE ACCESS
TO A SELF-GENERATING AUDIO RECORDING,
STORAGE, INDEXING AND TRANSACTION SYSTEM

Technical Field

The present invention relates generally to a method and apparatus to enable a broadcast listener to automatically purchase a music product such as a record album, cassette tape or compact disk without the intervention of an operator after hearing a music piece played on a radio station or music television station. More specifically, the preferred embodiment of the invention utilizes a programmed data processor, a digitally stored audio database containing the names of musical artists and groups, the names of pieces which have been recorded on the musical products, musical excerpts of these pieces, and a telephone system to replay this descriptive information through a telephone connection to a potential purchaser. This method utilizes the program schedule from a local radio station indicating when pieces will be played, a digital recording facility to automatically record excerpts of the music pieces played, a telephone system to decode DTMF tones from a touch tone telephone and an interface to a data communications network for communication with remote databases and computers.

Background Art

Radio networks offer the most significant marketing medium for the music industry to create awareness for music titles and artists. But music products such as records, cassettes and compact disks (CDs) are inconvenient to purchase at the time when the consumer has the maximum impulse to buy, after hearing a musical piece on the radio.

Additionally, the inability to automate many of the key functions of a radio based, direct marketing sales operation make it cost prohibitive for a single radio station to establish a direct marketing service linked to the music they broadcast. Station operators offer different programming in each market area making it unsuitable to link their stations into a national music retail network. As well, regulatory limitations curtail the number of stations a radio operator can own in a major market thereby limiting the number of listeners below the critical mass necessary to operate a profitable direct marketing music business.

Radio broadcasters provide no means to fulfil the impulse purchase nature of the radio business. When a radio listener hears a music piece they wish to purchase they must listen for, and remember, the artists name and title of the song. In many instances it is inconvenient to write this information down for future reference. In order to purchase the music product containing the song heard on the radio the consumer must be further motivated to travel to a music store to proceed with the purchase process. At the music store the

potential purchaser must determine if the selected music product is in stock and assess the pricing information.

The consumer is further constrained because they are unable to preview the songs on the music product they are considering because the music products are packaged and cannot be played at the store. The potential purchaser must remember and continue to be motivated by the music piece heard on the radio broadcast, possibly from days ago, and hope the other pieces recorded on the album are of sufficient interest to justify the purchase. The inconvenience and inability to sustain the impulse impetus severely impacts the purchase process.

Radio networks are unable to capitalize on the direct marketing opportunities they initiate through impulse music purchases because of the high cost of creating a direct marketing operation. Coordinating and tracking the music aired with the music products to be sold, recording of musical excerpts to be previewed, customer service operations and order fulfilment are all high overhead activities requiring a large dedicated staff with a separate skill set than radio station personnel. The cost for a radio station to establish a direct marketing operation far exceeds the returns from the music selling proceeds derived from a single radio station.

Cable television shopping networks have successfully developed large direct marketing networks based on national coverage by telecasting their programming over many cable companies reaching millions of potential purchasers.

Radio station operators are unable to market music products in the same manner because station operators broadcast different music programming in each market preventing the linking of these stations into a common national market.

Radio is the most widely received broadcast medium throughout the world. The problems as previously described have prevented radio networks from being utilized for a mass media, direct marketing, music retail business.

Disclosure of Invention

In view of the foregoing, one objective of this invention is to resolve the problems which inhibit the successful development of a direct marketing music business for the radio industry. In this regard, it should be apparent that there exists a need in the art for a method of operating an automated system which tracks radio audio segments enabling radio broadcast listeners to select, preview and purchase a music product containing the music piece listened to for a radio broadcast.

It is therefore an object of this invention to provide an automated transaction system to record and track radio audio segments enabling a radio listener to use their telephone to recall and preview, on-demand, music pieces previously broadcast thereby assisting the listener in the purchase of a music product such as a record album, cassette or CD. The invention provides the

consumer with a timely method to purchase a musical product by supplying all of the required information to conveniently make a music product purchase.

It is another object of the invention to provide a method for an automated transaction system to service multiple radio broadcasts simultaneously, thereby creating a mass radio audience for the direct marketing of music.

These and other objects are achieved by a method of and apparatus for tracking and recording a radio broadcast using a telephone interface connected to a programmed data processor such that when a potential purchaser calls a designated telephone number advertised by the radio station, for example 1-800-RECORDS, a telephone interface provides the listener with the name of the musical artist and the song titles in the reverse order played during the broadcast, starting with the current piece played. The selection, from the current artist played, to the music product the potential purchaser wants to order, is controlled by the potential purchaser using the touch tone telephone keys or voice input. When the potential purchaser reaches the song and artist of interest, further details can be related such as the other songs recorded on the album, pricing, availability and delivery information.

The invention can playback through the telephone, on instructions from the caller, excerpts or the entire song, as broadcast over the radio network, to assist the caller with the purchasing process.

When the potential purchaser indicates they are ready to order, the automated order system obtains the correct name and shipping address by accessing a name and address database responsive to the consumers telephone number or credit card information. The system also records the consumer's credit card information and obtains credit authorization. The invention then transmits the complete order to the fulfilment warehouse for shipment of the musical product to the purchaser.

It is a further object of this invention to provide a method and apparatus whereby multiple radio stations can be supported simultaneously, offering services on a local, regional or national basis providing the economies of scale and mass audience to support the sales volume necessary to operate a profitable direct marketing service. When a potential purchaser dials the advertised number such as 1-800-RECORDS they are directed by audio prompts to indicate by touch tone entry or voice input the call letters for the radio station to which they are listening. The audio prompts are provided by a telephone interface that is connected to a programmed data processor which performs database functions. The potential purchaser's telephone number, input by the caller or supplied by the telephone company's (ANI) Automatic Number Identification service, is compared to all the radio station broadcast coverage zones offered by the participating radio stations. This comparison determines the radio stations within the broadcast range of the caller, providing a limited set of radio stations for the programmed data processor to sort and search based on the callers input of the station call letters. The input of the station call letters enables the programmed data processor to select the correct station

program schedule and related information. Thus a large number of radio stations, dispersed locally, regionally, nationally and internationally can be supported by one automated system.

The inventive method also includes the step of efficiently selecting the correct radio station based on touch tone input. Although, each of the telephone keys 2 through 9 have three related alphabetical characters, callers need only to input four telephone key strokes for the four station call letters. The programmed data processor only recognizes the input for the participating radio stations broadcasting in the callers area as determined by the telephone number and broadcast coverage comparison previously described.

It is a further object of this invention to automate the manual and time-consuming functions. The inputting of the radio station play schedule in advance of the broadcast as well as the tracking of the program schedule during the broadcast day requires significant overhead if undertaken manually. As the service expands, and many radio stations are added to the service, the tracking of the various program schedules becomes unmanageable from a manual standpoint.

One component of the method and apparatus of the invention is a system for management of the radio station's program schedule. A radio station's program schedule is produced days and sometimes weeks in advance of broadcast. The program schedule is organized chronologically in the order musical pieces are broadcast and includes information such as the title of the song, the recording artist and group, as well as the day and time the piece is to be broadcast. A radio station broadcasts hundreds of musical pieces each day and the input of the program schedule by an operator is both time-consuming and prone to manual input error. The present invention enables the automation of the program schedule input by utilizing a data communications link and a communications interface such as a facsimile interface to receive the program schedule directly from the radio station into the programmed data processor. The communication interface such as a facsimile board is resident in the programmed data processor and in conjunction with a imaging software, such as a character recognition package, automatically interprets and directly stores the stations program schedule and associated information on a programmed data processor.

The radio station program schedule contains timetable information as well as information describing the music pieces played such as the title, artist and group name. The program schedule is accessed by a audio description creation system which is connected to the programmed data processor. The audio description creation system creates the audio description heard by the caller over the telephone when inquiring about a particular music piece. The audio description information describes the music piece outlined in the program schedule and the music product containing the music piece, along with other related information such as product pricing. The audio description creation system digitally records the audio and is connected to various input devices such as a compact disc player, cassette player, digital audio tape and a microphone. An announcer accesses the program schedule file on a display screen

and reads the description information into the microphone creating the audio description file for each music piece. The announcer has access to previous recordings stored in an audio description archive which can be accessed via a data input terminal connected to the audio description creation system enabling previously recorded audio descriptions to be referenced.

It is another object of the invention to automate the recording and storing of the music excerpts for the music pieces outline in the program schedule. These audio segments can be accessed by the potential purchaser to assist in the purchase process and to verify to the caller they are purchasing the music product containing the music piece listened to during the radio broadcast. The automated record and store process is accomplished by inserting a signal such as a tone or pulse at the beginning of each music piece broadcast. A receiver is tuned to the broadcast containing the music pieces to be recorded and a signal detector triggers the digital recording of the piece by the programmed data processor. The music piece is recorded for a specified time such as ten seconds providing an audio segment of the music piece.

Coordination of the audio description file with the program schedule is accomplished through a synchronized time schedule whereby the program schedule file and the recording of the audio segments on the programmed data processor are initiated at the same time. Each station's program schedule is stored in chronological order enabling the coordination. Another method of implementing the signal insertion enables information to be encoded as part of the selection signal and decoded into data for use by a programmed data processor. Information such as the program schedule number or music piece number can be incorporated into the selection signal enabling the coordination of the audio description with the program schedule. Information can be encoded into the selection signal through means such as multiple pulses or combination of tones and pulses.

The invention also provides the information for a potential purchaser to automatically order a music product without having heard one of the pieces through a radio broadcast. For instance when the potential purchaser dials the telephone number a telephone system audibly requests the potential purchaser to touch 1 on their touch tone telephone if they want to order a music piece they have just heard played on the radio, or touch 2 if they want to order a music product from the automated music catalogue. If the potential purchaser touches 2 the invention will then proceed to determine the musical product to be ordered by asking the potential purchaser to select the type of music and to input the artists name or group name using the touch tone telephone keys. Once the correct artist or group is determined the system can reference all the music products performed by that artist or group and provide the potential purchaser with the names of the music album and the recording media available such as CD, record or cassette along with pricing. Further information can also be made available such as the names of the pieces of each piece recorded on each music product along with excerpts to preview each song. The invention conveniently

provides all the information required to make a purchase. Some of this information is not available even at the record store.

When the potential purchaser indicates they wish to buy a particular music product the system determines the shipping address and credit authorization and then places the order for the music product with the fulfilment warehouse.

In the case where more than one main artist or group performed on a music product or the purchase process was too complex, the potential purchaser can be bridged to an operator who can obtain and input any required data and assist the caller through the purchase process.

The invention can also be utilized with other broadcast services such as a music television telecast. Viewers of music television program or channel, access the invention in the same manner as previously described but enter the station designation such as call letters, channel number or advertised pseudo-name enabling the invention to recall the pertinent program schedule relating to the viewed television program or channel. The audio portion of the music broadcast, would be recorded and utilized to assist the viewer in the purchasing process. The invention can simultaneously support orders originating from both radio listeners and television viewers.

Other applications of the invention are also possible. The broadcast can consist of content other than music whereby products are advertised within a broadcast and the invention enables listeners to select, preview and purchase items advertised for sale over the network. The audio segments for these products would be recorded in the same manner as previously described for the music pieces and the products would match the program schedule as input prior to the broadcast.

The invention also extends to a digital as well as analog broadcast format whereby the selection signals are digital signals inserted into a digital broadcast.

The foregoing features of the invention, as well as the advantages provided thereby, are explained in greater detail hereinafter with reference to preferred embodiments illustrated in the accompanying drawings.

Brief Description of the Drawings

Figure 1 is a block diagram of the self-generating audio recording, storage, indexing and transaction system according to the present invention;

Figure 2 illustrates an example of a Program Schedule reference file;

Figure 3 illustrates an Artist and Group Name reference file;

Figure 4 illustrates the telephone area and exchange code, station call letter code and touch tone input database file;

Figure 5 is a table and map of North American telephone area codes;

Figure 6 is the touch tone telephone keypad lay out; and

Figure 7 is an entity relationship diagram illustrating some of the principles of the invention.

Best Mode for Carrying Out the Invention

In order to explain the present invention in detail, reference will be made in particular to Figure 1.

In Figure 1, the reference number 1000 designates the radio station schedule input terminal device located at a remote radio station that can communicate with the programmed data processor 1010, located at the central site 1025, and input the program schedule of music to be broadcast on the remote radio station. In the preferred embodiment the radio station schedule input terminal 1000 is the computer system at the radio station that schedules the time of play for both commercials and musical program content. This terminal device 1000 is equipped with a modem and a communications program so that it can automatically dial the communications interface 1050 of the programmed data processor 1010 and input the program schedule including the artists name, name of the musical piece, and the date and time the music is to be played. This information can be coded to reduce the transmission time as there could be hundreds of music pieces broadcast each day.

Alternatively the radio station schedule can be automatically input by FAX (facsimile) using a computer or typewritten print out of the stations program schedule to transmit the stations schedule from the local FAX machine at the radio station to the central site 1025. At the central site 1025, the FAX receiver is a FAX board mounted within either a stand alone personal computer or the programmed data processor 1010 that would sequentially provide each incoming FAX message with its own identification number prior to storing the FAX digitally on the computer systems hard drive. In the process of setting up the FAX call a hand shake protocol is established between the sending and receiving FAX machines such that the receiving FAX machine can determine, by error free data transfer, the telephone number of the transmitting FAX machine.

Alternatively, the station's FAX number can be established through, the telephone company supplied, (ANI) Automatic Number Identification service. The programmed data processor 1010 utilizes this telephone number as an index to select the optimal algorithm to convert the FAX images to data. For example, message number 101 assigned by the FAX receiving board is associated with radio station WHAM FM because of the stations digitized telephone number received in the hand shake protocol. The programmed data processor 1010 then accesses the interpretation protocol that matches the FAXed data for WTAM FM to convert the character images sent from the radio station FAX into ASCII characters to be stored on the programmed data processor 1010 in the program schedule file 1060.

For example, radio station WTAM FM could utilize a computer printer that produced text in the Roman font. Each line on their schedule begins with time of play, followed by duration, artist name, then the name of the music piece. A different radio station, identified through the handshake protocol by their telephone number as WPAT AM, utilizes a different scheduling computer to print out their program schedule using the Tudor font highlighting the artist name first, followed by the musical piece, time of play and duration. Because the

programmed data processor 1010 knows the identity of the sending FAX machine it can apply the optimum algorithm to interpret the text font and determine from the text placement the contents of the page. This approach enables the programmed data processor 1010 to automatically file the FAXed program schedule of the remote radio station in a fixed digital format in the program schedule file 1060 associated with a particular radio station. An example of the format to which the program schedule files are processed is illustrated in Figure 2.

Alternatively, the terminal device 1000 could be a nonprogrammable terminal or data source connected via a network to the communications interface 1050, interacting on line to input the program schedule. The program schedule data could also be input using a touch tone telephone with voice prompting when connected to the telephone interface 1020 or input by voice into a section of the telephone interface that recognized spoken numbers and words through voice recognition. A coded version of the radio station program schedule makes the input easier and quicker. The schedule data could also be read over the telephone to an operator who would input the data. As this program schedule data is received from all of the participating radio stations it is stored in the program schedule 1060 of the programmed data processor 1010.

Music television channels and other telecasters can also utilize the above-mentioned methods to forward and store their program schedules for use by the system.

Other station specific information such as a station's top ten music listing or most requested hits can also be input in the above mentioned manner.

The digitized audio description file 1070 is created using the audio description creation system 1080 which is connected to the programmed data processor 1010. The audio description creation system consists of a set of audio input devices, such as a CD player 1085, cassette player 1086, record player 1087, audio tape player 1088 and microphone 1089 for an announcer to record audio descriptions.

The audio description file 1070 consists of the audio description information describing the music piece and an audio segment consisting of an excerpt of the music piece. The audio description information corresponds to the audio recording of the text description of each music piece listed in the program schedule stored in the program schedule file 1060. The announcer uses the display screen 1081 to recall the program schedule from the programmed data processor 1010 for each radio station. As well, additional information concerning the music piece such as the name of the music product containing the music piece and pricing can be input into the creation system via the attached data input terminal 1082 or personal computer and stored on the audio description creation system available to the announcer for audio recording.

For example, the station program schedule, after receipt from a participating radio station, would be loaded onto the audio description creation system 1020. The program schedule file 1060, an example of which is referenced in Figure 2, contains the station code or identifier for the station 2000, field

1, date and period of the program schedule broadcast 2005 field 2, number of music pieces in the time period 2010 field 3, chronological schedule number 2015 field 4, time of broadcast for a particular music piece 2020 field 5, artist or group name 2025 field 6, title of the music piece 2030 field 7 and the pointer to data file 2035 field 8. Parts of this schedule information can be coded to reduce the transmission time from the radio station to the system. For example, a particular artist or group would be listed in a reference table with an artist or group number followed by a music piece reference number for the song broadcast. The coded entry would be made in the program schedule at the radio station and FAXed to the central site 1025. A standardized music reference system can be utilized by all reference table based stations or customized tables implemented whereby the station reference table conversion is conducted by the programmed data processor 1010 when the imaging and interpolation process occurs for the incoming program schedules. If a customized music reference table is utilized by a station then a copy of the table would be resident on, or available to, the audio description creation system 1020 to conduct the conversion into artist and song title information.

Once a station's program schedule is stored on the system it can be updated if changes are required. To accommodate updates, access will be provided to the program schedule file stored on the system. This access will enable station personnel to use their touch tone telephone to call into the Now Music system and utilize their telephone keypad to modify the program schedule.

By calling into the telephone interface 1020, station staff can step through their current play-list with the song titles or chronological play-list numbers verbally related back to the caller using text-to-speech processing. The text-to-speech technology is well adapted for this application and is included as part of the telephone interface 1020. For example, the * key on the telephone will delete a song from the current play-list while the # key can add or insert an entry. The # key would be followed by a music reference number which relates to a song, artist and album title contained in the previously described, coded music reference table. After entering any changes the new program schedule information would be verbally related back to the caller confirming the play-list changes.

For the purposes of recording the music title portion of the audio description, the audio description creation system 1080 performs an initial sort of the music pieces listed in the program schedules to remove redundant entries for the same artist and music piece. The artist name 2025 field 6 and the name of the music piece 2030 field 7 contained in the program schedule 1060, or the code representing it, is compared to the data description archive file 1066 containing all previous listings for which audio descriptions already exist. The announcer is then presented, on the display screen 1081, with the listings that require an audio description. The announcer then reads the artist's name and title of the music piece into the microphone 1089 and stores them in the

audio description file 1070 while at the same time updating the audio description archive file 1084.

Information not contained in the program schedule such as pricing, album name or other background can be input by the data input terminal 1082, prior to audio recording, and stored as part of the data description archive file 1066 to be included in the audio description by the announcer.

The music product containing the music piece outlined in the program schedule can then be loaded into its respective player such as a CD player 1085, on the audio description creation system 1080 and the audio segment digitized, compressed and stored into its associated audio description file 1070 while also updating the audio description archive file 1084. The audio segment can consist of an excerpt of the music piece or the entire music piece.

The announcer would then depress the space bar or other key of the display terminal 1082 to indicate completion of that audio input and the linking of the entry in the program schedule with the corresponding audio description. The link is made through a database which utilizes the pointer to data file, 2035 field 8, which is added to each music piece in the program schedule and references the corresponding audio and data description.

The announcer can then proceed with the next descriptive item of that musical product which would be displayed on the display screen 1081 for the announcer to record onto the system. This process can be repeated for each piece recorded on the musical product and referenced in the database by product name. Both the audio description archive file 1084 and the data description archive file 1066 are automatically updated with the new entries.

Instead of using a staff announcer's voice to provide the audio description it is possible to have the recording artist provide their own music descriptions on a recording medium such as an audio tape and have it sent to the creation system site to be input and included as part of the audio description via the audio tape recorder 1088. Alternatively, recording artists can provide song and album introductions utilizing the recording capabilities of the telephone interface 1020 by using their touch tone telephone 1030 to follow special voice prompts to record personalized messages directly on the system.

When the audio descriptions for all of program schedule entries and potentially for all of the new music products have been processed by the audio description creation system 1080, the digital audio description file 1070 on the programmed data processor 1010 is updated with the new audio descriptions contained in the audio description archive file 1084. As well, the data file 1065 is also updated with the new files contained in the data description archive file 1066. The program schedule 1060 is updated with the revised schedule containing the pointer to data file 2035 field 8 linking to the corresponding audio and data description.

Acquiring the music products and manually recording the music pieces is both expensive and time-consuming. The system offers a method for

automatically recording the audio segments of the music pieces broadcast. This is accomplished by digitally recording the music in real time directly from the broadcast and storing the recorded segments into the associated audio description file 1070 on the programmed data processor 1010.

In the radio industry, recordable media, such as Digital Audio Tape (DAT) or digital hard drives are used to prerecord many hours of music for preparation and play by radio stations. The music on the digital media is prepared in accordance with a station's program schedule. Existing technology enables a signal such as a pulse or DTMF tone to be recorded on the DAT and included with the broadcast to trigger remote audio and video equipment. This capability is commonly used in the radio and television industries to trigger equipment remotely for the broadcast of advertisements.

According to the invention, the automated record and store process is accomplished by inserting a selection signal such as a tone or pulse at the beginning of each music piece to be recorded from the broadcast. In Figure 1 the receiver 1090 is connected to the signal detector 1091 which is connected to the programmed data processor 1010. The receiver 1090 receives the broadcast containing the music pieces to be recorded and a signal detector 1091, when it detects the appropriate signal, triggers the digital recording of the piece by the programmed data processor 1010. The recording of the music piece continues for a specified time, such as ten seconds, providing an excerpt of each music piece denoted by the selection signal. The digitizing facility can be part of the signal detector 1091 or contained within the programmed data processor 1010.

An additional signal can be included to notify the programmed data processor 1010 to stop recording rather than a timer based approach. Having a signal start and stop the recording function enables the entire music piece to be recorded whereby the additional signal is appended to the end of the music piece.

The real-time recording of the music piece is linked to the program schedule 1060 enabling the recorded audio segment to be stored in the correct audio description file. The recording of the music pieces is initially time synchronized with the program schedule for each station. A receiver 1090 and signal detector 1091 is dedicated to each station requiring real-time recording. Knowing the station code or identifier that the receiver is dedicated to, the programmed data processor 1010 loads the correct program schedule 1060, for the station it is recording, based on the station code 2000 field 1, and the current time and period of broadcast 2005 field 2. The system clock is used by the programmed data processor to locate the current music piece played as indicated in the program schedule, using the time of broadcast 2020 field 5. The incoming audio segment, as detected by the signal detector 1091 is recorded into its corresponding audio description file 1070 as referenced by the pointer to data file 2035 field 8 in its program schedule 1070. After the initial synchronization, the recording of the music pieces into the audio description file 1070 follows in chronological order with the program schedule

for that particular station. For example, if synchronization between the incoming audio segments and the current program schedule occurred with the first music piece listed in the program schedule as indicated by the chronological schedule number 2015 field 4, then the next audio segment detected would be recorded into the audio description file corresponding to the next program schedule listing containing the chronological schedule number of two.

When the programmed data processor 1010 reaches the last listing in a program schedule it loads the next schedule for that particular station and proceeds to synchronize and record when the next audio segment is detected. Establishing the last listing in a program schedule can be accomplished in various ways such as comparing the number of music pieces in the time period 2010 field 3 and the chronological schedule number 2015 field 4 for the current listing. If the two fields match, the next program schedule is loaded for synchronization with the next incoming audio segment. Another method of detecting the end of a program schedule involves the addition of a delineator at the end of the program listing which when reached causes the loading of the new program schedule. Alternatively or as well, a delineator signal can be added to the broadcast signaling the programmed data processor to refer to the next program schedule.

Specific signals or multiple signals can be inserted for various purposes such as to synchronize the program schedule with the automatic recording of the music pieces. When creating the program schedule the station can indicate the time of the synchronizing signal and upon receiving the program schedule, the programmed data processor 1010 automatically interprets the signal placement along with the rest of the program schedule information. Many stations currently utilize a beginning of the hour signal for advertising purposes and this beginning of the hour signal can be detected by the programmed data processor and utilized to synchronize the program schedule.

Another method of implementing the selection signal enables information to be encoded as part of the inserted signal and converted into data by the signal detector 1091. Information such as a program schedule number or a music piece reference number can be incorporated into the selection signal enabling the coordination of the program schedule 1060 with the recording of the music pieces into the correct audio description file 1070. The selection signal information can be encoded in the inserted signal through various means such as multiple tones or a combination of tones and pulses. For example, when DAT tapes are prepared containing the music for a days broadcast, a signal such as DTMF tones can be inserted prior to each music piece whereby the program schedule number accompanies the music piece in the broadcast. This signal information could be sent before, during or after the music piece is broadcast.

For example, the 46th music piece in a program schedule can be preceded by the tones representing a 4 and 6. The signal detector 1091 would detect and decode the signal and pass the information to the programmed data processor 1010. The programmed data processor 1010 would reference the chronological schedule number

2015 field 4, within the current program schedule and record the audio segment into the correct audio description file 1070.

The encoding and inserting of information in the broadcast can be utilized in several ways. A coded music piece reference number indicating the title and artist name can be inserted into the broadcast and received, detected and decoded for use by the programmed data processor 1010 to coordinate the recording of the audio description and the synchronization of the program schedule.

In an alternate method of operating the system, the insertion of information such as the music piece reference number enables the system to create the program schedule as the broadcast occurs. This is accomplished by creating a reference table as previously described whereby a station inserts the music piece reference number according to a standardized or station specific music reference table which is known to the radio station and stored on the programmed data processor 1010.

If the music piece reference number refers to an audio description not available on the programmed data processor 1010 then the programmed data processor can access the audio description archive file 1084 to retrieve the associated audio description. For operation without a predefined program schedule, utilizing the insertion of a music piece reference number, the audio description archive file 1084 can be located on the programmed data processor 1010 to provide more efficient operation.

The selection signal or other information, can be sent as data with the broadcast signal through methods such as the side band frequency of the broadcast signal or as digital data contained within a digital radio transmission or digital television signal.

As well, the selection signal can be utilized to pass messages in real-time to the programmed data processor 1010 such as in the case whereby a disc jockey at a broadcast station manually inserts a specific signal as part of the broadcast. The signal is decoded by the signal detector 1091 and passed to the programmed data processor 1010, relaying messages such as to skip a music piece and continue with the next listing in the program schedule thereby instructing the programmed data processor to skip the current listing in the program schedule.

The real-time insertion of information into the broadcast enables radio stations that conduct live or request shows, to insert information such as a music piece reference number with the music piece broadcast, enabling the programmed data processor 1010 to locate the corresponding audio description or trigger the recording facility if necessary.

The selection signal methodology also applies in the case of a music television channel, music video program or a music station associated with a television telecast such as provided through a cable television telecast, satellite broadcast or television signals distributed via the telephone network.

The selection signal is inserted into the audio portion of the signal and detected and potentially decoded as previously described.

An alternate signaling method enables video information to be inserted and detected as the selection signal. In the case of video signaling, the receiver 1090 becomes a television receiver and the signal detector and decoder is a video decoder able to decode the embedded video signal contained within the broadcast.

In some cases, broadcast stations are unable to insert a signal into their broadcast in which case an alternate data communications facilities can be established, such as a modem and a telephone line, to transmit the real-time information to the communications interface 1050 thereby enabling the programmed data processor 1010 to locate the corresponding audio description or trigger the recording facility.

If a request show runs throughout the day the communications costs for an external data facility can become significant. In an alternate method of operating the system, a polling procedure can be implemented for the transmission of the program schedule and station specific information. With the polling method, the disc jockey inputs the program schedule onto the schedule input device 1000 such as a personal computer which stores the information locally at the broadcast station. When a customer call is received at the telephone interface 1020 requesting station specific information such as the last song broadcast, the communications interface 1050 utilizes a data communications facility, such as a modem and telephone line, to connect with the remote schedule input device 1000 located at the broadcast station. A data file transfer is then conducted whereby the station's information such as the program schedule is transferred to the programmed data processor 1010 which reformats the information and stores it in the program schedule file 1060. The telephone interface 1020 then relates the requested station specific information to the caller. Program schedule information for a predetermined time, such as the last hour, can be included when the data file transfer is received from the remote schedule input terminal 1000. If multiple customer calls are received by the telephone interface 1020 requesting the same station specific information or requesting information which is already available to the programmed data processor 1010 then the information can be accessed without re-initiating communications with the remote schedule input terminal 1000. This polling method is for request shows which broadcast for long durations and when customer calls do not occur for every song.

The audio description archive file 1084 can be updated at the end of a recording period such as the end of the day by up-loading the audio segments and audio descriptions recorded from the broadcast in the audio description file 1070 that do not already exist in the archive. Music pieces, whether prerecorded when the artist name and titles are recorded by the announcer, or real-time recorded from the broadcast, are recorded once and can be referenced by multiple program schedules, multiple times within a given program schedule

and further referenced if needed for other station specific information such as a station's top ten song listing. Each audio description is filed in the audio description archive file 1084 contained on the audio description creation system 1080. The audio description archive file 1084 enables easy reference and repeated use of the audio descriptions. This is significant from an efficiency standpoint because in most cases a relatively limited number of music pieces receive the majority of the broadcast play. The archive files 1084, 1083, and 1066 can be located locally on the programmed data processor 1010 or remotely connected by a data communications facility.

The audio description creation system 1080 is also the means to create the area code and call letter file 1075, which when located on the programmed data processor 1010, is the basis for determining the call letters of the radio station being listened to by the potential purchaser.

For example each of the approximately 130 telephone company area codes, see Figure 5, have less than 999 unique local exchange codes. Each telephone exchange code defines a small portion of the geographic area of the telephone area code that it is located in, such that a specific exchange code can only exist in one city or town for that particular area code. Similarly, cellular and other wireless telephone services such as PCS (Personal Communications Services) have identification codes relating to cell and transmitter locations with defined geographic limits. Every radio station has an area of signal coverage that is publicly available on maps such that for every exchange code it can be determined which radio stations provide coverage within the boundaries of a particular exchange. For example, in area code 519, exchanges 293, 526, 765, 773, 565, 644, 523, 228, 482, 233, 234, 237, 268, 762, 235, 769, 287, 524, 238, 225, 269, 262, 263, 666, 247, 229, 652, 227, 289, 264, 232, 294, 874, 243, 782, 785, 631, 633, 527, 522, 764, 775, 866, 245, 296, 461, 693, 768, 236 are located in an area surrounding London, Ontario, Canada and these following exchanges are within the London city limits 432, 433, 434, 438, 439, 451, 452, 453, 455, 471, 472, 473, 641, 643, 645, 649, 657, 659, 660, 661, 663, 667, 668, 672, 673, 679, 681, 685, 686 and from these exchanges the following radio stations can be heard CBBL FM, CBCL FM, CIXX FM, CJBC FM, CJBK AM, CJBX FM, CIQM FM, CKSL AM, CFPL AM in London and CHLO AM in St. Thomas and CBEG FM, CHOK AM, CKJD AM, CJFI FM in Sarnia. By organizing this information in a database it is possible to determine from touch tone input, the call letters of the radio station listened to even though the touch tone keys have three alphabetic characters on each key as illustrated in Figure 6.

The area code and call letter file and database structure are illustrated in Figure 4 where the area code 4000 and the local exchange digits 4010 are the first two data fields followed by a third field 4020 which indicates the maximum number of radio stations that can be satisfactorily heard in that area and exchange code. A radio station is described in the next set of four fields which are repeated for each radio station. 4030, field 4 contains the numeric values of the touch tone keys that match the letters of the radio

stations call letters. For instance WPAT FM would appear as 9728 where the number 9 is contained on the touch tone key corresponding to the letters WXY. 4040 field 5 contains a 0 if the station is AM station or a 1 if FM. 4050 field 6 contains a number 0 to 9 indicating the type of radio station such as country, pop or rock. 4060 field 7 contains a pointer to an audio description of the station call letters so that the potential purchaser can be prompted with the station call letters combined with the type of station in the event the purchaser forgets the call letters. The radio station call letter fields would be arranged in sorted order to improve the speed of the retrieval.

The system would know in advance as part of the database that the first two stations listed in the above example, CBBL FM and CBCL FM have the same touch tone numeric values 22252 and would audibly ask the caller to select the correct station once it detected this conflict.

To determine the radio station call letters the potential purchaser's telephone area and exchange code digits are used as a retrieval key against the area code and call letter file 1075 to retrieve the set of radio station call letters that could be heard from that telephone exchange. The potential purchaser is asked to use the telephone to input the station call letters. The call letter numbers from the area code and call letter file 1075 are then compared with the numeric values of the station call letters input by the potential purchaser. If a match is established the system can then proceed to determine which music has been played on the selected radio station or what station specific information is requested. If a match is not found the potential purchaser can be verbally prompted with the types of radio stations in that area code and exchange, for example touch 1 for country, 2 for pop, which when selected, will allow the system to further prompt the potential purchaser with the radio station call letters that match the selected type of station. If this process does not determine the radio station, the potential purchaser can be bridged to a customer service operator, located at a customer service data terminal, 1040 to determine and input the radio station call letters.

As well as station call letters, other identifiers can be utilized in place of or in conjunction with the station call letters, for example, a radio station frequency number, television channel call letters, cable or television station number or advertised station descriptor. This entails an expanded version of the area code and call letter file referenced in Figure 4 whereby 4030, field 4 includes the touch tone numbers for additional identifiers.

In some cases, a music genre, such as rock or classical can be used as a station identifier whereby the caller is prompted by the telephone interface 1020 to use the touch tone telephone 1030 to make a selection corresponding to the music genre of the station listened to. This identification information in combination with the caller's telephone area and exchange code information significantly narrows and identifies the affiliates within the caller's broadcast range. If multiple affiliates exist with overlapping broadcast ranges

within the same music genre then a narrowed list of stations can be presented to the caller for the final selection of the station listened to by the caller.

Additionally, station operators may request their own specific telephone number for their listeners to access the service, in which case the called number would identify the station and enable the programmed data processor to recall the appropriate program schedule or station specific information.

The audio description creation system 1080 is also the means to create an artist name archive file 1083 which is updated every time a new artist adds a musical product. This artists name archive file 1083 updates the artists name file 1078 on the programmed data processor 1010 each time it is updated. The artists name file 1078 contains the touch tone key combinations and other related information for each artist or group name. This file is also partitioned into as many segments as a potential purchaser can identify as separate sets or styles of music. For example, 5 partitions can be created by dividing all artists or groups into the categories of soft rock, hard rock, pop, easy listening and country. Each of these categories can then be divided into single artists or groups. Then the artist and group names are converted into the numeric values of the touch tone keys that match the alphabetic characters of their names. For example, the letters A,B,C would all be represented by the number 2 which is the numeric value of the touch tone key containing them. A generalized version of this file is described in Figure 3 where 3000 field 1 contains a number between 1 and 5 representing the type or category of music. 3005 field 2 contains a 0 for an artist or 1 indicating a group. 3010 field 3 contains the name of the artist in touch tone representation of the ASCII characters of their name. Since the characters Q and Z and Space do not appear on the touch tone telephone keypad the number 1 is used to indicate either Q or Z and the number 0 is used to denote a space. The potential purchaser would be informed of these keyboard characteristics when prompted to input the artist or group name. 3020 field 4 would contain a pointer to the artist or group name in the data file 1065 referencing the pointers to all the musical products for the artist or group as well as pointers to the audio description of the artist's name, the names of the artist's musical products, the various pieces included in the musical products and musical excerpts of these pieces contained in the audio description file 1070.

When the updated program schedule 1060, data file 1065, area code and call letter file 1075, artists name file 1078, and audio description file 1070 have been loaded on to the programmed data processor 1010 along with the program to initialize and control the data processor, the system is ready to receive telephone calls ordering music products.

Referencing Figure 1, the potential purchaser uses a touch tone telephone 1030 to dial an advertised number such as 1-800-RECORDS (equivalent to 1-800-732-6737) to be connected to the telephone interface 1020. The telephone interface 1020 uses audio prompts to ask the potential purchaser to use the

touch tone keys to input their telephone number including the area code. Alternatively, this information can be supplied or verified by the telephone company ANI (Automatic Number Identification) service.

After receiving the telephone number the system asks the potential purchaser to touch 1 if they heard the music piece of interest on a radio station, or to touch 2 if they plan to order a music product not recently heard on the radio station.

If the potential purchaser touched 1 the telephone interface 1020 would ask the potential purchaser to input the call letters of the radio station to which they were listening, including AM and FM designations if necessary. Since the basic radio station call letters are four characters and each of the touch tone telephone keys with an alphabetical listing contain three possible characters, the potential for confusion as to which radio station identifier was input is very large. One of the concepts of the invention is to eliminate this confusion by using the caller's telephone area code and the mutually exclusive exchange code digits. This area and exchange code information enables the system to determine which city the call originated from and compare the caller input with a select group of radio station call letters consisting of only the stations participating in the service from that area. The request for the input of AM and FM designations would be requested when an equivalent set of base call letters, such as WPAT FM and WPAT AM, provide a potential conflict.

If the potential purchaser cannot remember the station call letters it is possible to use the area and exchange code digits to retrieve station descriptions from the area code and call letter file 1075 to verbally prompt the user with the call letters or station identifier for the affiliate stations available from their city. This audio prompting could also include general station descriptions such as Country and Western or Rock to help determine the exact station listened to.

Once the system has determined which radio station was listened to, the system can search the station's program schedule to determine the current piece being played and provide the prospective purchaser with the first level of description such as the artist's name. The telephone interface then directs the potential purchaser to touch 1 if it is the music piece in which they are interested or touch the 2 key to hear an excerpt of the music piece broadcast to confirm the music piece of interest or touch the number key # on their telephone to relate information for the previous piece of music played on the broadcast.

With each touch of the number key (#) the system would step back through each piece of music previously broadcast or telecast until the potential purchaser touched 1 to indicate reaching the music piece of interest. Listeners can also, through the telephone, enter the time they listened to a song to speed the retrieve process for those callers that were significantly delayed in calling the service.

Upon reaching the music piece of interest, the system audibly informs the potential purchaser of the formats available for the music product

selected, such as CD, cassette tape or record album and provide the pricing, shipping and other details.

The system would then ask the potential purchaser to touch the asterisk key * on the touch tone telephone 1030 if they want to order the music product. Alternatively they can press the number key # if they want more details.

If the potential purchaser touches the number key # the other musical pieces on the product would be described and, if requested, excerpts could be played so that the potential purchaser had all the required information to make the purchase. Pressing the asterisk key * begins the order process.

When the asterisk key * is pressed to order the musical product, the system would use the caller's telephone number to determine the shipping address. The system accomplishes this by requesting the communications interface 1050 to connect to an outside database 1090 to provide the address associated with the caller's telephone number. This address could also be obtained from a local CD ROM, attached to the programmed data processor 1010, that contains the street addresses for the respective telephone numbers. If the caller requests a different shipping address, they can leave a voice message on the audio response system 1025 or be connected to a customer service operator.

As the address retrieval process is proceeding, the telephone interface 1020 audibly requests the purchaser to input their credit card number on the touch tone telephone 1030. The programmed data processor 1010 then directs the communications interface 1050 to contact the credit card issuer 1095 and obtain a credit authorization number which would enable the system to subsequently invoice the customer's credit card account upon shipment.

With the shipping address and credit authorization known, the programmed data processor 1010 directs the communications interface 1050 to connect to the fulfilment warehouse 2000 and place the order for the requested music product. If the product is not in stock the fulfilment warehouse computer informs the programmed data processor 1010 through the communications interface 1050 which then instructs the telephone interface 1020 to inform the customer of the out of stock condition.

Once it has been determined that the product is in stock an order is placed with all the information to ship the product and create the appropriate records to invoice the purchaser and record the transaction for further accounting and statistical purposes.

In each of these steps, if the caller experiences problems not easily handled by inputting information via the touch tone telephone the caller can be connected through the telephone interface 1020 to a customer service operator, who would obtain the required information verbally for input into the system via the customer service data terminal 1040. The customer service operator has complete control of the session with the caller once the bridge connection has been made. For example, the customer service operator, can over the telephone, play the recorded excerpts for the caller, obtain and enter

shipping addresses or explain credit problems. In general the customer service operator is the last resort when the automatic system is unable to complete the order process.

The system will also support orders from callers not directed by a broadcast but interested in purchasing a music product. For example, the potential purchaser can initially, upon calling, be prompted to press the number 2 on their touch tone telephone indicating they were not a radio listener but wished to use the automated music catalogue service whereby the system would proceed to automatically determine the required musical product and provide all the information, including the playing of music excerpts, to enable the potential purchaser to order a selected music album. The system accomplishes this by narrowing the scope of possible music products by first asking the potential purchaser to touch 1 if the artist of group is soft rock, touch 2 if hard rock, touch 3 for blues and touch 4 for country, then to indicate whether the music product is recorded by a group or single artist. Then the telephone interface 1020 requests the artists name followed by a terminator key such as the number key #, to be input using the touch tone keys on the telephone 1030. The type of music and the numeric representation of the artist or group name is combined together as a retrieval key. Matching the retrieval key with the artists name file 1078 provides access to the pointer for the selected artist's name in the data file 1065. The data file 1065 contains a pointer to the artist's name in the audio description file 1070 for the telephone interface 1020 to audibly relate the artist or group name and ask the potential purchaser to confirm the selection of the correct artist or group, using the touch tone keys.

Once the correct artist has been identified the system retrieves the names of musical products for the selected artist stored in the data file 1065 and relates them in the reverse order of their release. These names have pointers to audio descriptions in the audio description file 1070, which when played to the potential purchaser, assist in determining which music product is of interest. By using the touch tone keys, the potential purchaser can hear excerpts from any music product until satisfied they have all the required information to initiate the purchasing process by touching the asterisk key *. Once the asterisk key * is depressed the system will automatically proceed with the purchase process as previously described.

It is contemplated that a 1-900 telephone number can be used for the service where the potential purchaser would be charged by their telephone company for the telephone call on either a per call or duration basis.

It is further anticipated that record and music clubs can use this invention to assist in describing and selling their products. As well, record stores can use this invention to allow potential customers to hear excerpts from the musical products over telephone lines. These services could be offered from one central site or through smaller local distributed systems networked together.

In both of the above-mentioned examples the music product number or unit code can be used to access the album index of possible pieces to be previewed, thereby reducing the retrieval time to obtain the music information required to make a purchase.

It is further contemplated that specific components of the system can be located remotely and networked to provide a distributed approach to reduce communications costs. For example, the telephone interface 1020 can contain local file storage capabilities and be located remotely from the programmed data processor 1010 such that the telephone interface, and its audible response and preview functions, can be located in major cities.

Additionally, access to the system can be provided by personal computer whereby a communications network address such as an Internet address would be promoted by a broadcaster. A personal computer user would access the system through the system's communication interface 1050 and would use personal computer commands instead of touch tone telephone input to preview and order music. The personal computer would communicate utilizing digital data and access the digital audio files available to the programmed data processor 1010. The personal computer user would be directed to navigate throughout the system through voice or visual prompts provided through the personal computer.

It is further envisioned that the system would store, index and record a combined audio and video signal, such as a music video, recorded from a telecast such as a cable or satellite broadcast in the same manner as previously described for a radio broadcast but utilizing digital video capture facilities.

A terminal device such as a personal computer would access the system via a network connected to the communication interface 1050 to access audio and video information as broadcast or as outlined in a telecaster's program schedule. The audio and video portions of the signal would be stored in separate files or in a manner maintaining access to the audio by telephone users of the system.

The system could further be utilized in conjunction with a billing facility such as a 900 telephone number to enable terminal users such as personal computer user to review a music video channel's program schedule in order to receive and store specific information locally on their personal computer.

Having now described the preferred embodiment of the invention, reference will be made to Figure 7, which gives an overview of some of the principles of the present invention. As illustrated, the present invention employs data processor 7010 which is provided with a suitable user interface 7012. In the presently preferred embodiment, the user interface is integrated with the existing telephone and communications infrastructure, so that persons may interact with the system using conventional DTMF telephone equipment or other terminal equipment such as personal computer as described above. Connected to data processor 7010 is a subsystem 7018 for providing prerecorded audio or combined audio and video descriptions of the program material (e.g.

recorded music) that the caller may wish to purchase. Subsystem 7018 may be implemented using hard disk storage, optical storage, digital audio tape (DAT) storage, or the like. The program material (e.g. recorded music) may be prerecorded from the media played over the air, or it may be prerecorded from the live broadcast using a suitable AM, FM or television receiver and suitable digitizing (analog to digital conversion) equipment. Also connected to data processor 7010 is a program schedule input system 7020, which may be any suitable means for inputting the program schedule, play list or station specific information identifying what program materials have been or will be broadcast, including optical character recognition equipment for inputting program schedules or play lists provided in printed form and telefacsimile equipment for inputting the program schedule or play list information via FAX.

Data processor 7010 is further provided with a database system 7014 for storing the program schedule, suitable data or pointers from which the prerecorded description may be obtained, reconstructed or generated. An audio description subsystem 7016 is coupled to data processor 7010 to provide the selected audio description to the user via the user interface 7012. The audio description subsystem may include digital to analog conversion equipment for converting digitally prerecorded audio description information into an analog form suitable for distributing serially over the telephone. Alternatively or additionally, the audio description subsystem may include synthesis equipment for performing text to speech conversion on text data files for the creation of audio description information.

The audio description information may also include video information either stored on the audio description subsystem 7016 or on a separate subsystem connected to the data processor 7010.

While the invention has been described with regard to the presently preferred embodiment, it will be understood that the invention is capable of certain modification without departing from the spirit of the invention as set forth in the appended claims.

I claim:

1. A computer-implemented audio information system to provide users with audible information concerning program materials disseminated according to a program list, comprising:
 - a processing system for execution by a computer;
 - a user interface coupled to said processing system, said user interface providing means for placing user inquiries regarding the program material;
 - a database coupled to said processing system;
 - a first input means coupled to said processing system for inputting information reflecting audio descriptions of said program materials;
 - a second input means coupled to said processing system for inputting program list information regarding a plurality of program material items; and
 - an audio description output means coupled to said processing system and to said user interface;said processing system having:
 - means for correlating said audio descriptions of program material with said program list information and for storing said correlated audio descriptions and program list information in said database;
 - means for responding to a user inquiry, placed through said user interface, about an item in said program list, by retrieving a selected audio description from said database; and
 - means for further responding to said user inquiry by causing said audio description output means to produce an audible message based on said selected audio description.
2. The audio information system of Claim 1 wherein said processing system is a computer program running on said computer.
3. The audio information system of Claim 1 wherein said user interface includes a mechanism for coupling said user interface to a touch tone telephone.
4. The audio information system of Claim 1 wherein said user interface further includes a telephone interface and wherein said user inquiries are placed using telephone DTMF codes entered through said touch tone telephone.
5. The audio information system of Claim 1 wherein said first input means includes a radio receiver.
6. The audio information system of Claim 1 wherein said first input means further includes an audio signal digitizer.

7. The audio information system of Claim 1 wherein said first input means further includes a device for extracting said audio descriptions from prerecorded program materials.

8. The audio information system of Claim 1 wherein said second input means includes an optical character recognition system.

9. The audio information system of Claim 1 wherein said second input means further includes a telefacsimile transceiver.

10. The audio information system of Claim 1 wherein said audio description output means includes a text to speech conversion device.

11. The audio information system of Claim 1 wherein said audio description output means further includes a digital to analog conversion device.

12. A system for on-demand remote access to a self-generating, audio recording, storing, indexing and transacting system comprising:

- at least one broadcast unit, said at least one broadcast unit allowing audio broadcast to remote locations and informing said remote locations of a telephone number;
- an emission device providing a selection signal to said at least one broadcast unit;
- a telephone interface device providing audio descriptive data to a programmed data processor, said audio descriptive data received via a telephone connection, said audio descriptive data at least one broadcast identifier, said programmed data processor including a data input unit for receiving a program schedule;
- a reception device providing reception for said audio broadcast;
- a detection device providing signal detection for said selection signal from said audio broadcast;
- a storage device digitally recording, compressing and storing detected audio segments on said programmed data processor;
- an audio description creation device comprising input devices selected from the group consisting of a compact disc player, a tape cassette player, a digital audio tape device, a videotape player, a multi-track audio tape recorder, a microphone and a data input device, said data input device creating an audio description file;
- a communication device coupled to said programmed data processor enabling access with remote databases and computers for credit authorization and placement of orders;
- a responsive device responding to the receipt of said at least one broadcast identifier, generating information in a first database and directing said program schedule and said audio descriptive data; and

a data processor attachment device coupled to said telephone interface device, said detection device and said communication device, said data processor attachment device directing said telephone interface device to communicate said audio descriptive data in a reverse chronological order to said remote locations.

13. The system in Claim 12 further comprising a timer controlling recording time of said detected audio segments, wherein only portions of musical pieces or audio programs is recorded.

14. The system in Claim 12 wherein said selection signal provides a reference point within said program schedule.

15. The system in Claim 12 wherein said program schedule is encoded and broadcast as said selection signal.

16. The system in Claim 12 wherein said selection signal occurs at the beginning of said audio segments to be recorded.

17. The system in Claim 12 wherein said selection signal occurs at the beginning and the end of said audio segments.

18. The system in Claim 12 wherein said selection signal comprises at least one of or a combination of a DTMF tone, a frequency tone or a time delay queuing pause.

19. The system in Claim 12 wherein said selection signal is contained within a signal not including said audio broadcast.

20. The system in Claim 12 wherein said selection signal further comprises at least one digital signal.

21. The system in Claim 12 wherein said selection signal is contained within a video broadcast.

22. The system in Claim 12 wherein said reception device comprises a radio receiver, a digital radio receiver, a television receiver, a cable converter, a digital cable receiver, a satellite receiver or a personal computer.

23. The system in Claim 12 wherein said audio broadcast is received by said telephone connection and transferred to said telephone interface.

24. The system in Claim 12 wherein said detection device includes a decoder device for obtaining numeric data from said selection signal for use by said programmed data processor.

25. The system in Claim 24 wherein said numeric data includes information relating to said program schedule or said audio descriptive data.

26. The system in Claim 12 wherein said audio descriptive data is stored on a separate system than said programmed data processor.

27. The system in Claim 12 wherein said audio descriptive data is stored on said telephone interface.

28. The system of Claim 12 wherein said audio description creation unit includes a text to speech conversion device.

29. The system of Claim 12 wherein said data processor includes a text to speech conversion device.

30. The system in Claim 12 wherein the said audio broadcast informs said remote locations of a common telephone number associated with said audio broadcast.

31. The system in Claim 12 wherein the said audio broadcast informs said remote locations of a specific telephone number associated with said audio broadcast.

32. The system in Claim 12 wherein said at least one broadcast unit includes a radio broadcast.

33. The system in Claim 12 wherein said at least one broadcast unit further includes a digital radio broadcast.

34. The system in Claim 12 wherein said at least one broadcast unit further includes a video broadcast.

35. The system in Claim 12 wherein a caller enters information using keys on a telephone, said telephone interface includes a conversion device for converting DTMF tones to numeric data for utilization by said programmed data processor.

36. The telephone interface of Claim 12 wherein said telephone interface includes a voice recognition device to acquire information from said caller.

37. The system in Claim 12 wherein said telephone interface receives said at least one broadcast identifier selected from the group consisting of a station tuning frequency, station call letters, a television channel allocation, a cable subscriber identification or a predetermined identifier.

38. The system in Claim 12 wherein said telephone interface receives said program schedule such that said caller enters information using said keys on said telephone or voice recognition to input a number representation referenced from a master listing of said audio pieces wherein said number representation is entered in a corresponding order of play over said at least one broadcast unit.

39. The system in Claim 12 wherein said audio description creation device is configured through a separate system comprising:
at least one computer system containing audio authoring software;
input unit comprising a compact disc player, a digital audio tape, a multi-track audio tape recorder, a microphone and a cassette tape player;
a communication unit transferring digital files to said programmed data processor;
an audio storage unit digitally compressing said audio descriptive data; and
a data input and display unit connected to said at least one computer system.

40. The system in Claim 39 wherein said audio description creation device creates said audio segments.

41. The system in Claim 39 wherein said communications unit communicates said audio descriptive data relating to said program schedule.

42. The system in Claim 39 wherein said communications unit includes said telephone connection, said program schedule is input via said telephone.

43. The system in Claim 39 wherein said communications unit receives said audio description information.

44. The system in Claim 12 wherein said data input unit includes a facsimile (FAX) machine or FAX interface board coupled to said programmed data processor to receive said program schedule.

45. The method in Claim 12 wherein said programmed data processor utilizes optical character recognition (OCR) to automatically interpret a facsimiled version of said program schedule.

46. The system in Claim 12 wherein said communications device receives said audio descriptive data.

47. The system in Claim 12 wherein said communications device consists of a data input terminal, personal computer or an input facility connected through a communications network.

48. The system in Claim 12 wherein said program schedule comprises a video schedule.

49. The system in Claim 12 wherein all apparatus is located at said at least one broadcast unit.

50. The system in Claim 12 wherein said broadcast unit informs said remote locations of a communications network address.

51. A method to provide a self-generating audio recording, storage, indexing and transaction system for remote listeners of a radio or television broadcast comprising the steps of:

broadcasting at least one radio or television signal on which signal a telephone number is advertised;

inserting of selection signal into said broadcast signal;

accepting of telephone input from said listener of said radio or television signal who provide at least the broadcast identifier of said radio station or television signal;

receiving of said radio or television signal;

detecting of said selection signal from within said radio or television broadcast;

digital recording, compression and storage of the detected audio segment;

provision of communications means for the input of the radio or television station program schedule into the programmed data processor;

receiving of input from input devices selected from the group consisting of a compact disc player, a tape cassette player, a digital audio tape device, a videotape player, a multi-track audio tape recorder, a microphone and auxiliary data input devices for the creation of a audio description file;

communicating means coupled to the programmed data processor enabling access with remote databases and computers for credit authorization and placement of orders;

generating of information in a first database responsive to receipt of a broadcast identifier, directing said audio program schedule and audio description information;

use of a programmed data processor coupled to the telephone interface, signal detection means and the communication means directing the

telephone interface to communicate to said listener the audio description information for said radio or television broadcast.

52. The method in Claim 51 wherein said broadcast identifier is spoken through a telephone and is manually input via a data terminal into said system.

53. The method in Claim 51 wherein a voice recognition device receives input from said listeners corresponding to said radio or television station identifier.

54. The method in Claim 51 wherein said broadcast identifier is selected from a group consisting of a station tuning frequency, station call letters, a channel allocation, a cable subscriber identification or a predetermined identifier.

55. The method in Claim 51 wherein said audio description file contains digital data relating to audio describing the title and artist of a listing in said program schedule.

56. The method in Claim 51 wherein said audio description file contains digital data describing the title of said program schedule listing and an audio segment.

57. The method in Claim 51 wherein said audio description information is created using text to speech translation to convert said program schedule listing or station specific information into an audio format.

58. The method in Claim 51 wherein said audio description information is transmitted by said communications mechanism and received by a personal computer device.

59. The method in Claim 51 whereby said telephone interface or said communications mechanism receive at least the music category of the broadcast station.

60. A system for on-demand remote access to a self-generating, audio indexing and transacting system comprising:

at least one broadcast unit, said at least one broadcast unit allowing audio broadcast to remote locations and informing said remote locations of a telephone number;

an emission device providing a selection signal to said at least one broadcast unit;

a telephone interface device providing audio descriptive data to a programmed data processor, said audio descriptive data received via a telephone

connection, said audio descriptive data at least one broadcast identifier, said programmed data processor including a data input unit for receiving a program schedule;

a reception device providing reception for said audio broadcast;

a detection device providing signal detection for said selection signal from said audio broadcast;

an audio description creation device comprising input devices selected from the group consisting of a compact disc player, a tape cassette player, a digital audio tape device, a videotape player, a multi-track audio tape recorder, a microphone and a data input device, said data input device creating an audio description file;

a communication device coupled to said programmed data processor enabling access with remote databases and computers for credit authorization and placement of orders;

a responsive device responding to the receipt of said at least one broadcast identifier, generating information in a first database and directing said program schedule and said audio descriptive data; and

a data processor attachment device coupled to said telephone interface device, said detection device and said communication device, said data processor attachment device directing said telephone interface device to communicate said audio descriptive data to said remote locations.

61. The system in Claim 60 wherein said communications device receives the said program schedule.

62. The system in Claim 60 wherein said audio description creation device includes a text-to-speech conversion system.

63. The system in Claim 60 wherein said programmed data processor further includes a text to speech conversion device for relating said audio description information to said listeners.

64. The system in Claim 60 wherein said audio broadcast unit informs said remote locations of a communications network address associated with said audio broadcast.

65. The system in Claim 60 wherein said audio broadcast unit includes a radio transmitter.

66. The system in Claim 60 wherein said audio broadcast unit further includes a television transmitter.

67. The system in Claim 60 wherein said at least one broadcast unit includes a video broadcast comprising both video and audio.

68. The system in Claim 60 wherein said at least one broadcast unit further includes a satellite transmitter.

69. The system in Claim 60 wherein said at least one broadcast unit further includes a cable television head end.

70. The system in Claim 60 wherein said at least one broadcast unit further includes a fiber optic head end and distribution network.

71. The system in Claim 60 wherein said at least one broadcast unit further includes a low power television transmitter.

72. The system in Claim 60 wherein said at least one broadcast unit further includes a digital video broadcast.

73. The system in Claim 60 wherein said programmed data processor directs said telephone interface for information from said listener utilizing computer generated voice prompts.

74. The system in Claim 60 wherein said telephone interface receives touch tone input or automatic number identification (ANI) relating to a caller telephone number.

75. The system in Claim 60 wherein said telephone interface receives said program schedule such that said caller enters information using said keys on said telephone or voice recognition to input a number representation referenced from a master listing.

76. The system in Claim 60 wherein said telephone interface receives and digitally stores said caller authorization and billing information.

77. The system in Claim 60 wherein said telephone interface connects said caller to a customer support operator.

78. The system in Claim 60 wherein said audio description creation device is configured through a separate system comprising:

at least one computer system containing audio authoring software;
input unit comprising a compact disc player, a digital audio tape, a multi-track audio tape recorder, a microphone and a cassette tape player;

a communication unit transferring digital files to said programmed data processor;

an audio storage unit digitally compressing said audio descriptive data; and

a data input and display unit connected to said at least one computer system.

79. The system in Claim 78 wherein said audio description creation device creates said audio segments.

80. The system in Claim 60 wherein said program schedule comprises a video schedule.

81. The system in Claim 60 wherein all apparatus is located at said at least one broadcast unit.

82. A method to provide a self-generating audio storage, indexing and transaction system for remote listeners of a radio or television broadcast comprising the steps of:

broadcasting of at least one radio or television signal on which signal a telephone number is advertised;

inserting of a selection signal into said broadcast signal;

accepting of telephone input from said listener of said radio or television signal who provide at least the broadcast identifier of said radio station or television signal;

receiving of said radio or television signal;

detecting of said selection signal from within said radio or television broadcast;

provision of communications means for the input of the radio or television station program schedule into the programmed data processor;

receiving of input from input devices selected from the group consisting of a compact disc player, a tape cassette player, a digital audio tape device, a videotape player, a multi-track audio tape recorder, a microphone and auxiliary data input devices for the creation of a audio description file;

communicating means coupled to the programmed data processor enabling access with remote databases and computers for credit authorization and placement of orders;

generating of information in a first database responsive to receipt of a broadcast identifier, directing said audio program schedule and audio description information;

use of a programmed data processor coupled to the telephone interface, signal detection means and the communication means directing the telephone interface to communicate to said listener the audio description information for said radio or television broadcast.

83. The method in Claim 82 wherein said audio description file contains the digital data describing the title and artist of said program schedule listing.

84. The method in Claim 82 wherein said audio description file contains digital data describing the title and artist of said program schedule listing and an audio segment.

85. The method in Claim 82 whereby said broadcast identifier is a music category or music genre of said broadcast unit.

86. A system for on-demand remote access to a self-generating, audio storing, indexing and transacting system comprising:

at least one broadcast unit, said at least one broadcast unit allowing audio broadcast to remote locations and informing said remote locations of a telephone number;

a telephone interface device providing audio descriptive data to a programmed data processor, said audio descriptive data received via a telephone connection, said audio descriptive data at least one broadcast identifier, said programmed data processor including a data input unit for receiving a program schedule;

an audio description creation device comprising input devices selected from the group consisting of a compact disc player, a tape cassette player, a digital audio tape device, a videotape player, a multi-track audio tape recorder, a microphone and a data input device, said data input device creating an audio description file;

a communication device coupled to said programmed data processor enabling access with remote databases and computers for credit authorization and placement of orders;

a responsive device responding to the receipt of said at least one broadcast identifier, generating information in a first database and directing said program schedule and said audio descriptive data; and

a data processor attachment device coupled to said telephone interface device and said communication device, said data processor attachment device directing said telephone interface device to communicate said audio descriptive data to said remote locations.

87. The system in Claim 86 wherein said audio description creation device is configured through a separate system comprising:

at least one computer system containing audio authoring software;

an input unit comprising a compact disc player, a digital audio tape, a multi-track audio tape recorder, a microphone and a cassette tape player;

a communication unit transferring digital files to said programmed data processor;

an audio storage unit digitally compressing said audio descriptive data; and

a data input and display unit connected to said at least one computer system.

88. The system of Claim 87 wherein said audio description creation means further includes a text to speech conversion device.

89. The system of Claim 86 wherein said data processor attachment device includes a text to speech conversion device.

90. The system in Claim 86 wherein the communications unit communicates said audio descriptive data relating to said program schedule.

91. The system in Claim 86 wherein said communications unit receives said program schedule.

92. A method to provide a self-generating audio storage, indexing and transaction system for remote listeners of a radio or television broadcast comprising the steps of:

broadcasting of at least one radio or television signal on which signal a telephone number is advertised;

accepting of telephone input from said listener of said radio or television signal who provide at least the broadcast identifier of said radio station or television signal;

provision of communications means for the input of the radio or television station program schedule into the programmed data processor;

receiving of input from input devices selected from the group consisting of a compact disc player, a tape cassette player, a digital audio tape device, a videotape player, a multi-track audio tape recorder, a microphone and auxiliary data input devices for the creation of a audio description file;

communicating means coupled to the programmed data processor enabling access with remote databases and computers for credit authorization and placement of orders;

generating of information in a first database responsive to receipt of a broadcast identifier, directing said audio program schedule and audio description information;

use of a programmed data processor coupled to the telephone interface and the communication means directing the telephone interface to communicate to said listener the audio description information for said radio or television broadcast.

93. The method in Claim 92 wherein said audio description file includes an audio device describing a selected title in said program schedule.

94. The method in Claim 92 wherein said audio description file includes an audio device describing title and audio segment in said program schedule.

95. The method in Claim 92 wherein said audio description file is created using text to speech translation to convert a program schedule listings or station specific information into an audio format.

96. A method to identify an audio broadcast for a broadcast listener by utilizing a combination of said broadcast listeners telephone number and station call letters comprising:

obtaining said broadcast listener telephone number including area and exchange code utilizing touch tone telephone input or through ANI (Automatic Number Identification);

obtaining broadcast identifier input by said broadcast listener utilizing touch tone telephone input;

creating a file on a programmed data processor organized by area code, the three telephone exchange digits and the call letters for stations that can be received for an area and telephone exchange code;

utilizing said broadcast listener area and exchange telephone codes to determine which said broadcast identifier match the said broadcast identifier input by the said broadcast listener.

97. The method in Claim 96 wherein said broadcast listener enters a AM or FM designation on the touch tone telephone to resolve a conflict when more than one station have the same call letters.

98. The method in Claim 96 wherein said telephone interface receives said at least one broadcast identifier selected from the group consisting of a station tuning frequency, station call letters, a television channel allocation, a cable subscriber identification or a predetermined identifier.

99. A method of identifying a radio station being listened to using a combination of a listeners telephone number and the music genre or category of the radio or television station, comprising the steps of:

obtaining a listeners telephone number and area code by touch tone input by the listener or through ANI (Automatic Number Identification);

creating a file on the programmed data processor organized by area code, the three telephone exchange digits and the genre or music category of the participating stations able to be received by a potential listener in each area code and telephone exchange;

prompting a listener to input through the touch tone telephone the genre or music category of the radio station listened to;

prompting of the potential purchaser to select the correct station call letters from an audio description of only those stations within reception distance, that match the selected station type.

100. The audio information system in Claim 1 wherein said audio description further includes video information.

101. The audio information system in Claim 1 wherein said user interface includes means for coupling to a personal computer.

102. The audio information system in Claim 1 wherein said audio description output means relates audio and video information.

103. The audio information system in Claim 1 wherein said user interface further includes a computer interface and said user inquiries are placed using commands entered through a keypad.

104. The audio information system in Claim 1 wherein said first input means further includes a television receiver device.

105. The audio information system in Claim 1 wherein said first input means further includes an video signal digitizer device.

106. The audio information system in Claim 1 wherein said audio description output means transmits digital information relating to a textual message.

107. The audio information system of Claim 1 wherein said audio description output means transmits digital information for storage on said user interface.

108. The audio information system of Claim 1 wherein said first input means includes means for extracting audio and video description from prerecorded material.

109. The system of Claim 12 wherein said communications means produces digital information to be stored on a user interface comprising a personal computer.

110. The system of Claim 12 wherein said communications means produces digital information relating to a textual message based on said selected audio or video description.

111. The system of Claim 12 wherein said audio description further includes video.

112. The system of Claim 12 wherein said recording means includes a video signal digitizer device.

113. The system of Claim 12 wherein said audio description creation means further includes a video signal digitizer device.

114. The system of Claim 60 wherein said communications means produces digital information to be stored on a user interface comprising a personal computer.

115. The system of Claim 60 wherein said communications means produces digital information relating to a visual message based on said selected audio or video description.

116. The system of Claim 60 wherein said audio description creation means includes a video signal digitizer device.

117. The system of Claim 115 wherein said communications means transmits digital information to be stored on said user interface comprising a personal computer.

118. The system of Claim 115 wherein said communications means transmits digital information relating to a textual message based on said selected audio or video description.

FIG. 1

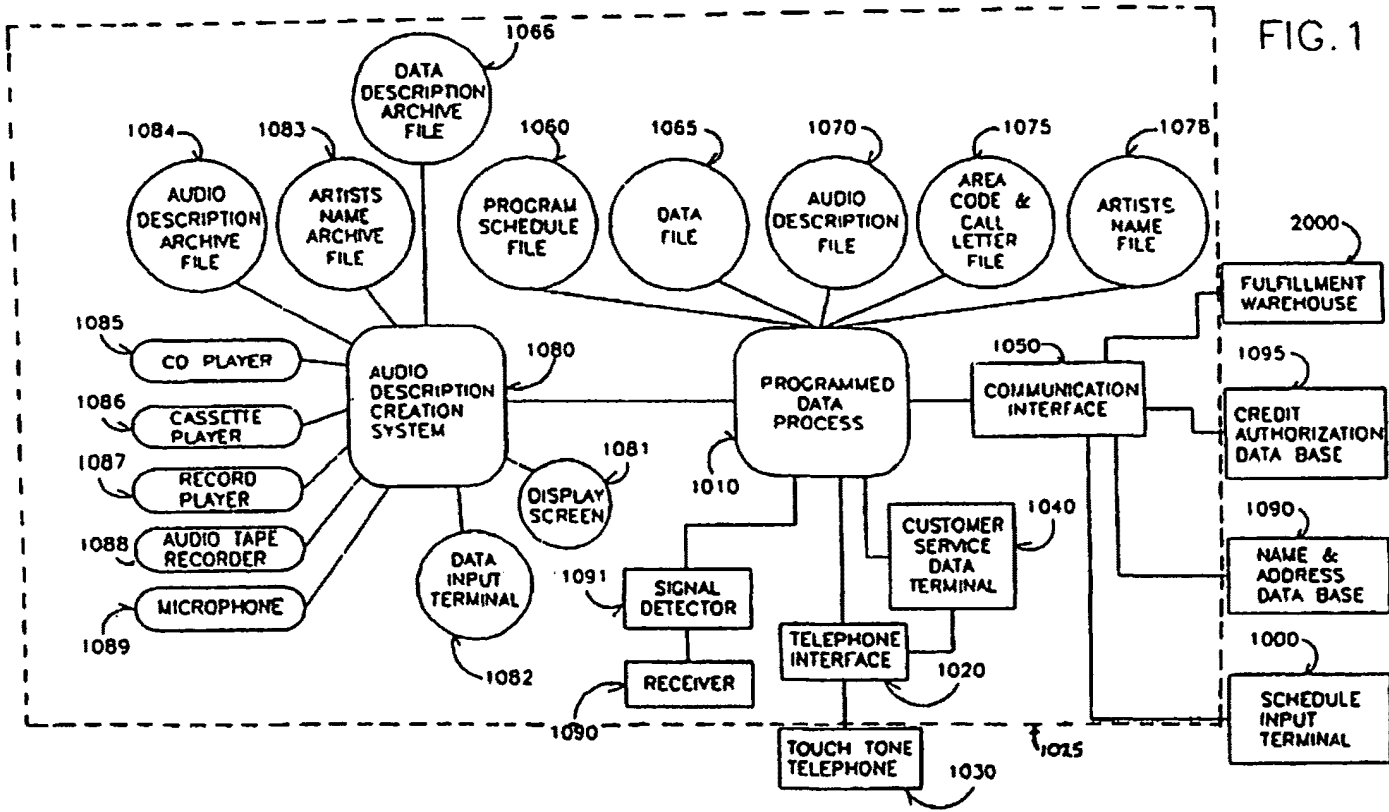

FIG. 2

| Field # | 2000 ① | 2005 ② | 2010 ③ | 2015 ④ | 2020 ⑤ | 2025 ⑥ | 2030 ⑦ | 2035 ⑧ |
|---------|-----------|-----------|-----------|-----------|-----------|-----------|-----------|-----------|
| | 9728 | 80694 | 176 | OO1 | O32406 | | | 9064 |
| | | | | OO2 | O32710 | | | 9123 |

Next Music Piece Broadcast

Program Schedule File 1060

- Field # ① Station call letters as numeric values of touchtone keys.
- ② Data and period of broadcast.
- ③ Number of music pieces in the time period.
- ④ Chronological schedule number.
- ⑤ Time of broadcast
- ⑥ Artist or group name
- ⑦ Title of music piece.
- ⑧ Pointer to data file.

WO 97/21291

PCT/CA96/00794

FIG. 3

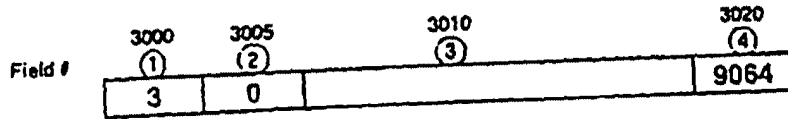

Artist Name File 1078

- Field #
- ① Category of Music, ie Pop, Rock
 - ② Artist or Group indicator, ie 0 for artist
 - ③ Name of Artist in touch tones
 - ④ Pointer to Artist or Group Name in Data File 1065

FIG. 4

| Field # | 4000 ① | 4010 ② | 4020 ③ | 4030 ④ | 4040 ⑤ | 4050 ⑥ | 4060 ⑦ | next station In area code and exchange ④ ⑤ ⑥ ⑦ | | | | last station ④ ⑤ ⑥ ⑦ | | | |
|---------|-----------|-----------|-----------|-----------|-----------|-----------|-----------|--|--|--|--|-------------------------|--|--|--|
| | 123 | 306 | 3 | 9728 | 1 | 3 | 49062 | | | | | | | | |
| | 123 | 309 | 2 | | | | | | | | | | | | |
| | 123 | 322 | 5 | | | | | | | | | | | | |
| | 123 | 338 | 2 | | | | | | | | | | | | |

Fifth Station

Area Code and Call Letter File and Database Structure

- Field #
- ① Telephone area code
 - ② Telephone exchange code (within previous Area Code)
 - ③ Maximum number of radio stations with signal coverage in the outlined area and exchange code
 - ④ Numeric values of touch tone telephone keys that match the letters of the radio station call letters
 - ⑤ AM or FM indicator
 - ⑥ Category of music indicator
 - ⑦ Pointer to the audio description for the station call letters.

CANADA - USA

Canada and the United States are divided into more than 100 telephone areas, identified by a three-figure Area Code. Fig. 5

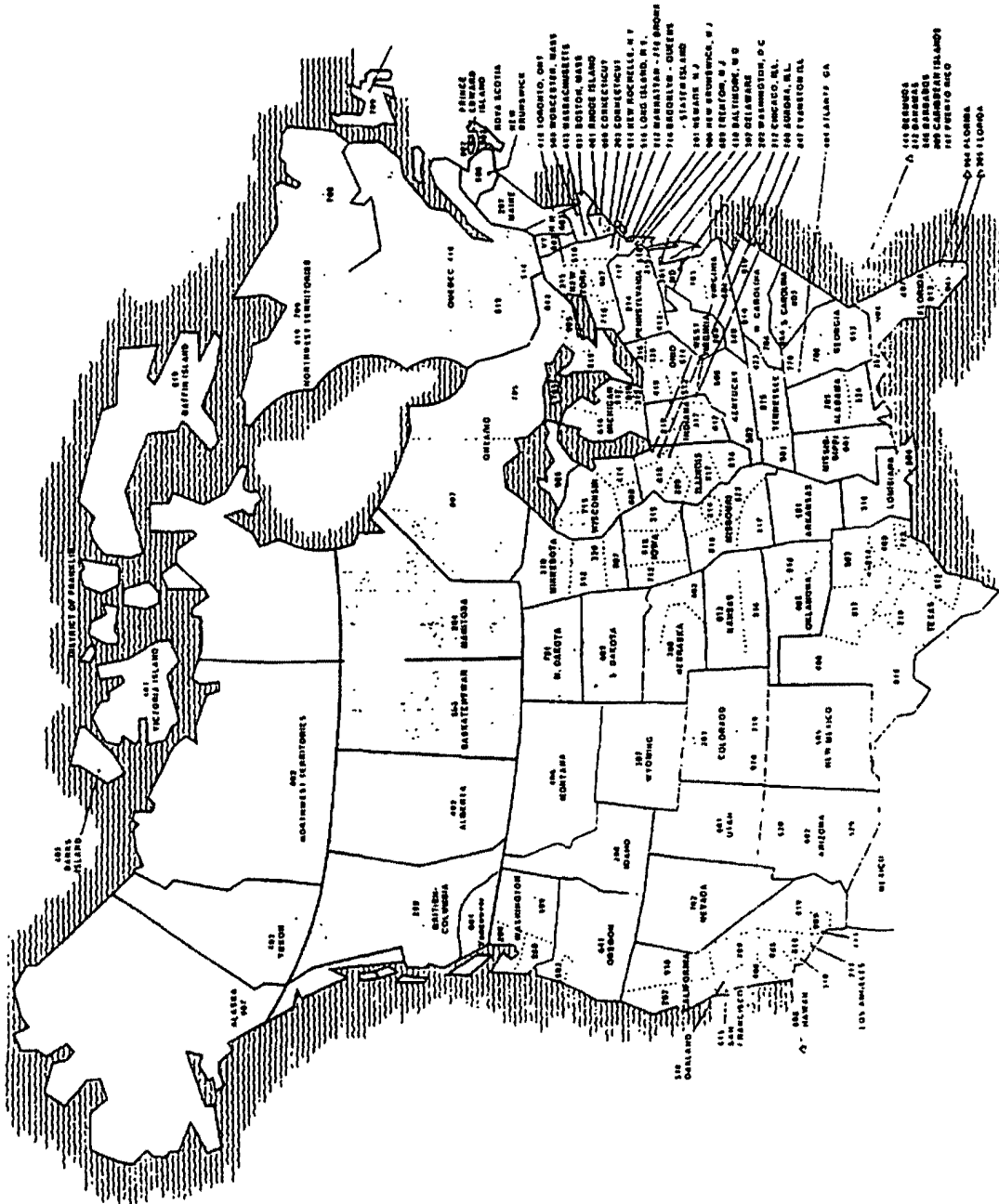
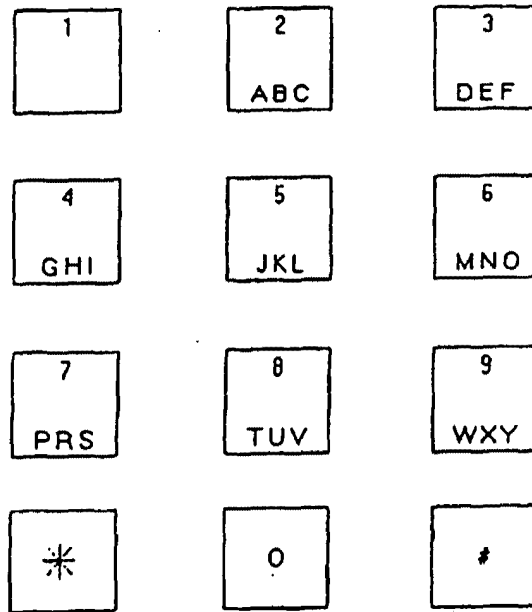
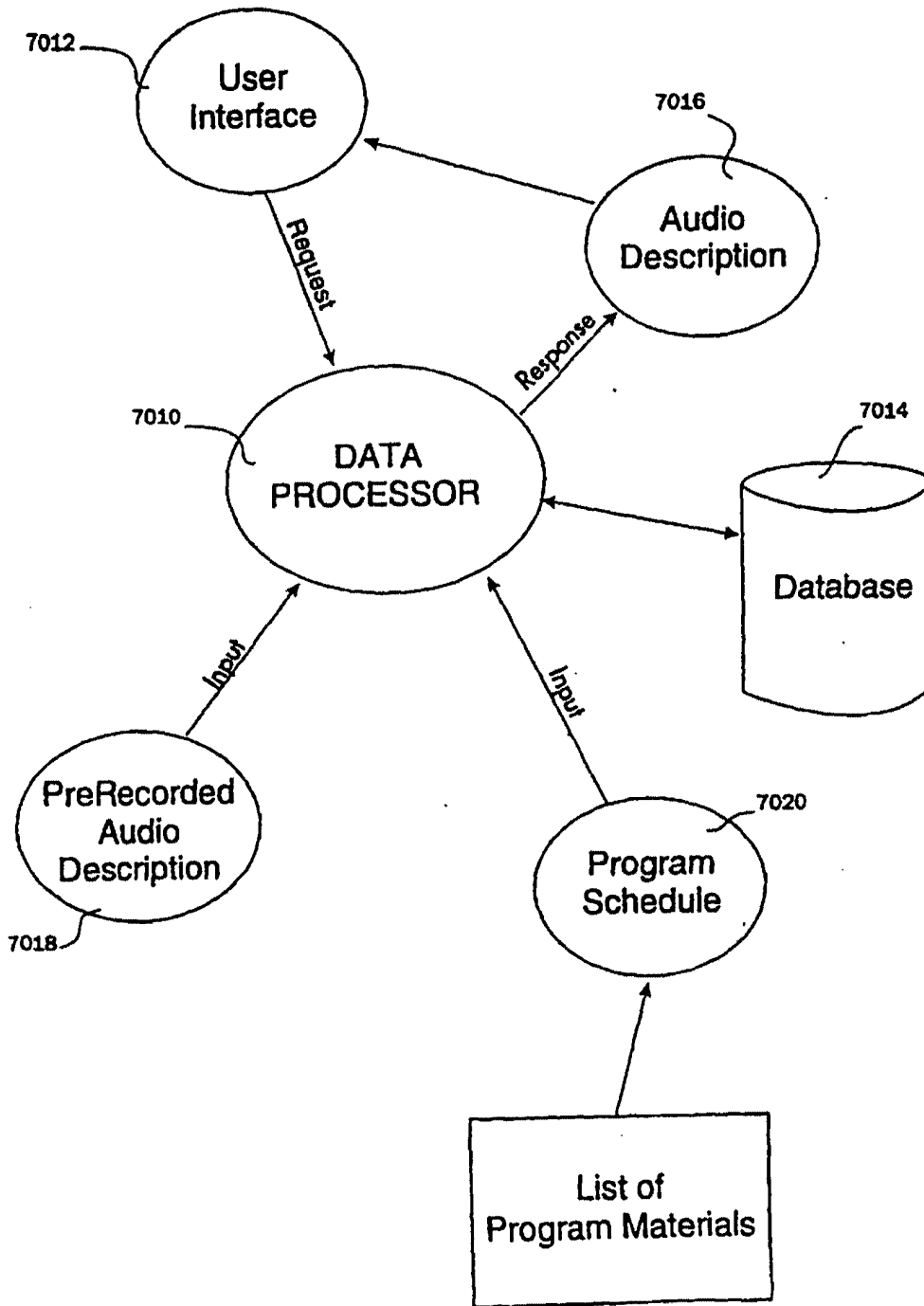

FIG. 6



NOTE: The letter O and Z are not contained on the keypad. In this embodiment the key containing the number 1 is used to denote a Q or Z. The key containing 0 is used to denote a space where required.

Figure 7



**This Page is Inserted by IFW Indexing and Scanning
Operations and is not part of the Official Record**

BEST AVAILABLE IMAGES

Defective images within this document are accurate representations of the original documents submitted by the applicant.

Defects in the images include but are not limited to the items checked:

- BLACK BORDERS
- IMAGE CUT OFF AT TOP, BOTTOM OR SIDES
- FADED TEXT OR DRAWING
- BLURRED OR ILLEGIBLE TEXT OR DRAWING
- SKEWED/SLANTED IMAGES
- COLOR OR BLACK AND WHITE PHOTOGRAPHS
- GRAY SCALE DOCUMENTS
- LINES OR MARKS ON ORIGINAL DOCUMENT
- REFERENCE(S) OR EXHIBIT(S) SUBMITTED ARE POOR QUALITY
- OTHER: _____

IMAGES ARE BEST AVAILABLE COPY.

As rescanning these documents will not correct the image problems checked, please do not report these problems to the IFW Image Problem Mailbox.



INTERNATIONAL APPLICATION PUBLISHED UNDER THE PATENT COOPERATION TREATY (PCT)

| | | |
|---|--|---|
| <p>(51) International Patent Classification ⁶ : G07F 7/08, 19/00, G06F 17/60 // 157:00</p> | <p>A1</p> | <p>(11) International Publication Number: WO 97/458 (43) International Publication Date: 4 December 1997 (04.12.)</p> |
| <p>(21) International Application Number: PCT/FI97/00315 (22) International Filing Date: 26 May 1997 (26.05.97) (30) Priority Data: 962553 24 May 1996 (24.05.96) FI 971248 24 May 1996 (24.05.96) FI 970767 24 February 1997 (24.02.97) FI (71)(72) Applicant and Inventor: VAZVAN, Behruz [FI/FI]; Vuokselantie 10 B, FIN-02140 Espoo (FI).</p> | <p>(81) Designated States: US, European patent (AT, BE, CH, I DK, ES, FI, FR, GB, GR, IE, IT, LU, MC, NL, PT, SE) Published <i>With international search report. Before the expiration of the time limit for amending claims and to be republished in the event of the receipt of amendments.</i></p> | |

(54) Title: REAL TIME SYSTEM AND METHOD FOR REMOTE PURCHASE PAYMENT AND REMOTE BILL PAYMENT TRANSACTIONS AND TRANSFERRING OF ELECTRONIC CASH AND OTHER REQUIRED DATA

(57) Abstract

A wireless/cellular terminal (1) and method is provided for allowing a user to perform remote purchase and bill payment transactions, and transferring of telecash and other required data to other terminals (2) or to the remote host computers (4) without using modem. In one embodiment, the terminal includes means for receiving and transmitting of bills and electronic cash directly to/from other terminals in a connectionless way without using the network (3). In the method of this invention, the payee's details such as account number, contact codes are sent/broadcast to the payee's terminal (e.g. mobile phone). The payer activates the payee's details upon which the bill and/or the required amount of telecash is sent to the payee's terminal or host computer. The terminal of this invention can operate as both the user's cellular/wireless electronic wallet and as his cellular/wireless telephone, thus providing a Mobile Wallet-Phone (MWP). By using MWP the user is able to send/receive payment messages and electronic cash directly to/from other terminals under a small terminal-to-terminal (1, 2) radio coverage or via the network (3). In another embodiment, the method of this invention provides a P-PIN (Payment-Personal Identification Number) process for user authentication which, when required, is used (in addition to the PIN-code which is used for mobile telephone services) to verify that the user has the right to use the terminal as his electronic wallet for paying by telecash or account transferring. In another embodiment of the method of this invention a bill inquiry is sent from other terminals or from the host computer to the user's terminal upon request of the user or automatically and/or continuously whenever the provided service requires so. In this case the user's terminal can be also a personal computer or television connected to the fixed internet or operating wirelessly.

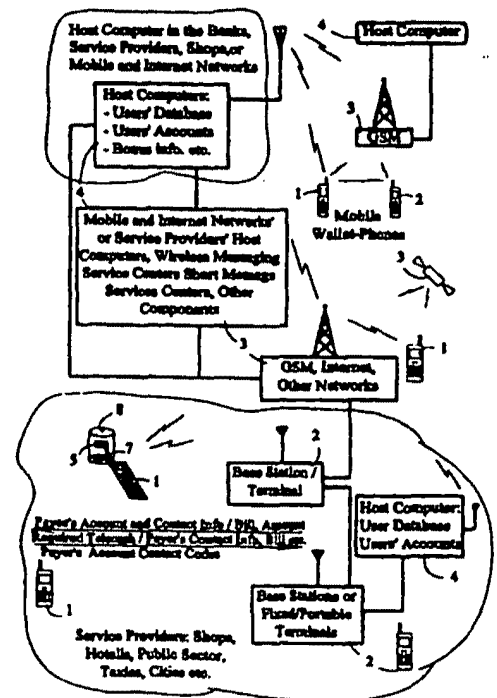

FOR THE PURPOSES OF INFORMATION ONLY

Codes used to identify States party to the PCT on the front pages of pamphlets publishing international applications under the

| | | | | | | | |
|----|--------------------------|----|--|----|--|----|--------------------------|
| AL | Albania | ES | Spain | LS | Lesotho | SI | Slovenia |
| AM | Armenia | FI | Finland | LT | Lithuania | SK | Slovakia |
| AT | Austria | FR | France | LU | Luxembourg | SN | Senegal |
| AU | Australia | GA | Gabon | LV | Latvia | SZ | Swaziland |
| AZ | Azerbaijan | GB | United Kingdom | MC | Monaco | TD | Chad |
| BA | Bosnia and Herzegovina | GE | Georgia | MD | Republic of Moldova | TG | Togo |
| BB | Barbados | GH | Ghana | MG | Madagascar | TJ | Tajikistan |
| BE | Belgium | GN | Guinea | MK | The former Yugoslav Republic of Macedonia | TM | Turkmenistan |
| BF | Burkina Faso | GR | Greece | ML | Mali | TR | Turkey |
| BG | Bulgaria | HU | Hungary | MN | Mongolia | TT | Trinidad and Tobago |
| BJ | Benin | IE | Ireland | MR | Mauritania | UA | Ukraine |
| BR | Brazil | IL | Israel | MW | Malawi | UG | Uganda |
| BY | Belarus | IS | Iceland | MX | Mexico | US | United States of America |
| CA | Canada | IT | Italy | NE | Niger | UZ | Uzbekistan |
| CF | Central African Republic | JP | Japan | NL | Netherlands | VN | Viet Nam |
| CG | Congo | KE | Kenya | NO | Norway | YU | Yugoslavia |
| CH | Switzerland | KG | Kyrgyzstan | NZ | New Zealand | ZW | Zimbabwe |
| CI | Côte d'Ivoire | KP | Democratic People's Republic of Korea | PL | Poland | | |
| CM | Cameroon | KR | Republic of Korea | PT | Portugal | | |
| CN | China | KZ | Kazakistan | RO | Romania | | |
| CU | Cuba | LC | Saint Lucia | RU | Russian Federation | | |
| CZ | Czech Republic | LI | Liechtenstein | SD | Sudan | | |
| DE | Germany | LK | Sri Lanka | SE | Sweden | | |
| DK | Denmark | LR | Liberia | SG | Singapore | | |
| EE | Estonia | | | | | | |

**Real Time System and Method For Remote Purchase Payment and Remote Bill
Payment Transactions and Transferring of Electronic Cash and Other Required Data**

5

Background of the Invention

Field of the Invention:

10

This invention relates to systems for purchase and bill payment transactions and transferring of electronic cash and also terminal-to-terminal wireless transmission of the required data without using modem.

15 **Description of the Related Art:**

The WO96/04618 publication has disclosed a terminal which can perform purchase payment and bill transactions via a modem coupled to or integrated into the terminal. The whole system provided in above publication is a modem-based system where the user's credit card information and the terminal's serial number are sent to a host computer for validating which after authorization by card issuing authority and a host computer the user is given the right for remote purchases. In its portable form the terminal also uses modem which is coupled through the telephone circuit to a transmitter/receiver. The portable terminal is not a wireless/cellular terminal so it does not exploit the wireless messaging for direct communication but the terminal is by means of a modem and circuit-switched call connected to a host computer and the payment procedure is performed during the established call. Moreover, in the above system transaction requests are connected to the remote host system through telephone line and the system is based only on circuit-switched communications whereby the credit card validation is performed during an established continuous call. Furthermore the above-like systems does not utilize electronic cash for purchase or bill transactions.

20
25
30
35 The GB2276258 publication disclose a system for utilizing credit information to verify and accept payment for an order on site at the door of a home contemporaneously by means of credit card. The above system is also a modem-based system and is based on circuit-switched communications neither messaging means of wireless communication for purchase and payment transactions. Neither the above system uses electronic money for payment transactions. In all already known methods the user establishes a circuit-switched call for performing transaction during the established call.

In the above-like systems the communication speed is low because of using modems or data cards which also makes the terminals more expensive. The communication is also expensive for the user because of the circuit-switched calls and the user, in some cases, is also required to purchase a

separate terminal for his purchases or bill payment transactions. Furthermore the user's credit information (credit card number) communication over the open networks is not secured. In all existing systems it is the customer whose credit card number is taken by the service provider for charging the customer whereas in a secure payment system the customer is not required to give any
5 credit information to the third parties. There continues to exist a need to further improve the efficiencies of the payment systems.

Summary of the Invention

10 It is an object of this invention to provide a secure payment system wherein the payer takes the account/contact number of the payee in order to pay to the payee's terminal or account. It is another object of this invention to provide a wireless/cellular terminal which can perform purchase payment and bill payment transactions and be used as the use's electronic wallet. It is another object of this invention to provide a wireless/cellular terminal to allow users the ability to conveniently and
15 remotely in a connectionless way perform these financial transactions and send and receive electronic money on terminal-to-terminal basis (as wallet-to-wallet) without using the network for transferring the required cash. It is another object of this invention to provide a wireless/cellular digital terminal to allow smart card holders to also remotely perform these financial transactions and also terminal-to-terminal transferring of electronic money. In this invention in order to prevent
20 forgery the payee's account number, whereto the founds can be transferred, is delivered to the payer and not the payer's account number to the payee, which could easily be used by unauthorized users.

It is another object of this invention to provide a service as an expansion of value-added data services of currently existing mobile communications systems. It is another object of this invention to utilize the wireless or cellular terminals such as mobile phones, pagers etc. to be used as the
25 inventive terminal (Mobile Wallet-Phone) thus creating a high value added service for mobile communication and providing the users one terminal which can be used as mobile telephone or pager when needed and as user's electronic wallet when required. Another object of this invention is to provide for wireless or cellular connectionless messaging with a remote host computer without establishing a circuit switched call.

30 It is yet another object of this invention to provide a connectionless method for terminal-to-terminal transmission of electronic money and payee's details such as contact code or number, account code or number, and bill without contacting the payee. It is another object of this invention to provide a connectionless method for broadcasting the payee's/service provider's details such as account number, contact codes, and the payable bill to the user's terminals continuously or whenever
35 required. It is yet another object of this invention to provide a method to send a bill format to the user's terminals in a connectionless way and whenever user requests it, to be filled and sent back to the required host computer or another terminal. It is yet another object of this invention to provide a terminal which is able to communicate with another terminal directly and without using the network for transmission of the required data. It is another object of this invention to provide a terminal

which is able to configure an adjustable radio coverage area (e.g. between one millimeter to five meter) for terminal-to-terminal wireless and modemless data transmission.

According to one embodiment of this invention, a wireless terminal, such as SIM-operated (SIM: Subscriber Identification Module) portable terminals such as mobile phones or pagers, portable
5 wireless personal computers can perform terminal-to-terminal remote purchase payment transactions, transferring of electronic money and user's details such as account number, contact code, address etc. in a connectionless way without requiring that the payee/payer contact each other or establish a circuit-switched call. The terminal includes means for receiving/transmitting of required information in a terminal-to-terminal wireless data communication without using the
10 network for transmission the information. The terminal can produce a small and adjustable radio coverage area wherein the terminal-to-terminal sending of the user details and transferring of electronic money and other information can be done using wireless messaging and in a transparent way to other terminals/users. In another embodiment of the invention the wireless/cellular terminal or service provider's terminal (such as cash register, computer etc.) or base station broadcasts the
15 payee's/service provider's account and bill information to all or to the required users' terminal which are under the radio coverage of the payee's/service provider's terminal/base station. Then the payer's terminal monitors the transmitted/broadcasted information which after the user activates the payee's details and sends the bill and the payee's details and when needed the required electronic money (telecash) to the payee's terminal or account at the host computer. In another embodiment of this
20 invention the user, by sending a message, can request the host computer or the payee's terminal to send the bill or bill format to the payer's terminal, in a connectionless way (using for example internet or short massaging means of mobile networks). Then user accepts the bill or fills in the bill format (a bill inquiry) the required information (together with the required amount of telecash, when needed) and sends it back to the host computer or the payee's terminal for receiving/accepting or
25 performing the bill.

In this invention the user's details such as account number, contact codes, numbers are sent or broadcasted to other terminal, directly or via base stations, or via network, in order to be used by payers for remote purchase transactions, bill payment, transferring of telecash and other required data from terminal-to-terminal or between the terminals and host computer.

30 Other objects and many of the attendant features of this invention will be more readily appreciated as the same becomes better understood by reference to the following detailed descriptions and considered in connection with the accompanying drawings in which like reference symbols designate like parts throughout the figures.

35 Brief Description of the Drawings

FIG. 1 illustrates a general overview of the system including cellular/wireless and internet network, host computers and Mobile Wallet-Phones utilized in the invention.

FIG. 2 is a flow chart presenting the user authentication, sending the payee's details, bills, bill
40 inquiry, performing the transactions, sending the required amount of telecash to the payee's terminal/account in accordance to the present invention.

FIG. 3 is a terminal-to-terminal or base station-to-terminal or host computer to-terminal messaging of the payee's details, purchase and bill payment transaction messaging, and transferring of electronic money in a service provider environment in accordance with the present invention.

FIG. 4 is a flow chart between the payer's terminal, host computer and the payee's terminal.

5 FIG. 5 presents four examples wherein payee's/payer's terminal exchange contact codes, account information, required amount of electronic money, perform bill payment and transactions in a connectionless, modemless, wireless and terminal-to-terminal way, or terminal-to-base station-to-terminal way, or terminal-to-terminal-to-host computer.

FIG. 6 is a top view of the terminal in accordance with one embodiment of the present invention.

10 FIG. 7 presents an example of a connectionless method for parking payments, in accordance with the present invention.

FIG. 8 presents an example of a connectionless method for parking reservation, in accordance with the present invention.

15 FIG. 9 presents two Mobile Wallet-Phones which can send and receive information, account numbers, contact codes, required amount of telecash (i.e. electronic money) and exchange other required data directly with each other under their own adjustable radio coverage without using the network, in accordance with one embodiment of the present invention.

Detailed Description

20

Referring now to the drawings, and more particularly, to FIG. 1, there is shown a block diagram of the overall system including cellular/wireless and internet networks (3), host computers (4) and user's wireless/cellular terminals "Mobile Wallet-Phones" (1, 2) or fixed terminals/base stations (2) in accordance with the invention. The terminal (1, 2) is able to send and receive the required account
25 numbers, contact codes, telecash, bills and bill format and the products' details (such name and price) in a connectionless way either without using the network (3) or via the network. The base stations of the network (3) or service providers (2) are also arranged so that they send the required information for purchase and bill payment transactions, such as the payee's account number or codes, and bill format to the users terminal (1) continuously or whenever required. For example when the
30 user terminal is under the coverage of base station (2) the network/base station broadcasts/sends the payee's/service provider's name and account number to the payer's terminal. Then the payer's Mobile Wallet-Phone (hereinafter MWP) monitors the payee's account number, contact code etc. (hereinafter payee's detail), then the user selects/activates the required payee's details which may be allocated for a specific service such as parking and send the bill and(or) required telecash to the
35 payee's terminal (2) or account (4) directly or via base station or via network. The payee's and payer's MWPs and fixed/portable terminals (1, 2) can exchange information, send and receive required amount of telecash directly to each other without the involvement of the network or host computer (4). The host computer (4) includes, as much as required, the users' details, data, accounts, the service provider's details etc. When the user purchases something for example in a shop by
40 means of his/her MWP, the seller's terminal can send the bill and payment to the host computer (4)

where users have accounts. The host computer (4) takes the required bonuses into account so that the user does not require to have a different bonus card in order to give to the seller for storing the (gained) bonus in the customer's account but the required bonus can be stored in his account while shopping is done by his MWP without requiring a separate bonus card. The network (3) can be a terrestrial or satellite network. The mobile wallet-phones (1, 2) are wireless/cellular, either terrestrial or satellite or both, single mode/band, dual mode/band or multimode/multiband terminals/phones or pagers, transmitter/receivers which can also whenever required configure their own radio coverage area under which they can send and receive the required information and telecash to/from each other without using the network. Alternatively by means of terminals (1, 2) the user can request the network/host computer or other terminal to send a bill format which includes at least one question which can be answered (filled in) by user and sent back to the required host computer or other terminals. The host computer also takes into account the currency by which a bill or purchase has been performed so that when the host computer (4) receives the bills and payments from a payer's terminal, it checks the received information, the currency unit of the telecash or checks the payer's/payee's accounts in order to define by which currency the amount should be paid to the payee's account. The exchange of the money is done in a real time and then both the payee's/payer's terminals are acknowledged by a short message. In FIG 1. there is also shown that the user's terminal (1) is able to monitor (receive) the product's (8) details (such as name, price and other required information needed to perform the bill payment) from a tag/card or label (5) which is labeled or by other means connected/printed on the product package (for example a can of mushrooms). The tag or card (5) can be a microprocessor loaded with the required details and which is also able to radiate/transmit the required details over a very small area (for example 1 millimeter). The tag or card (5) can be also made from an environment-friendly radiating material and loaded with the required product's details (i.e. the information which is broadcasted/radiated with a very small radi coverage). When the tag/card (5) is (for example) touched by the antenna (7) of user's terminal (1) the terminal receives and monitors the product's details. The user can pay for the selected product (8) by sending the product's details (and when needed, the required amount of telecash to the cashier, shop keeper's terminal (2) or host computer (4) or to the host computer of the bank where at least the customer (payer) has an account which can be debited/charged for the purchase performed. Alternatively the user's terminal (1) can be integrated with an electronic and digital (image) camera by which the bar codes (5) of a product (8) can be read (transferred into the terminal as an image or black and white code) in order to select the product user wants to buy and pay for without requiring to use any infrared reading devices. This application of the present invention can be seen as the best killer application for terminals having digital image processing means. Although several inventions has been made to provide mobile phones with digital camera's features providing video telephony in mobile phones but because of the lack of good applications such products cannot have a widespread market in the near future. For example the willingness of people to participate in video telephony has been seen as a barrier for mass production of video telephony products. But shopping by means of a mobile phone integrated with an appropriate camera can

seen as a killer application for mobile phones having digital image or mobile video telephony features. For example in FIG 1 the payer's terminal (1) can be integrated with a micro or nano digital camera in order to read the product's (8) bar codes (5) (or any other information including the product's details and price) and transfer them to the terminal (1) wherein the product details can be monitored on the screen of the user's terminal, and the terminal further arranges the product details in a shopping list on the screen. Then the user can send the bill and payment to the payee, as mentioned above, or cancel the list or an item from it, if he does not want to buy the selected product.

FIG. 2 presents a flow chart, where is shown that the MWP's user is authenticated by means of an additional code called P-PIN (Personal-Payment Identification Number) if a PIN is already used for telephone services. The user can use the same number for both PIN and P-PIN in order to remember it better. In one embodiment of this invention, first the MWP operates as the user's telephone i.e. the user has entered his/her PIN-code to the terminal for access to the network (3) for telephone service: so that the MWP is in the telephone mode. According to the invention in order to provide a secure payment device and method the user is prompt to enter in addition to the PIN code another code, P-PIN, for using his mobile phone as a payment device, when required. After entering the P-PIN the mobile phone becomes a mobile wallet-phone so that it can be used both as a mobile phone and a the user wallet, thus Mobile Wallet-Phone. After that the P-PIN has been entered or spoken by use to his terminal (1, 2) an authentication procedure takes place either in the terminal (1, 2) and user's smart card (e.g. SIM) or between the terminal i.e. smart card (SIM) and network/host computer. The user can also be registered and authenticated in network's AuC (Authentication Center) HLR (Home Location Register) or other future intelligent component of the network or in the host computer. When the user is authenticated either in MWP (1) or network/host computer (3, 4), the user can perform teleshopping, bill payment and purchase transactions and exchange money with other terminals (1, 2) or host computer (4). In order to receive the payee's details (i.e. account number, contact number etc.) the user can activate a function such as "payments" or "service provider" in his terminal (1, 2) either before authentication or after or without authentication. Then the terminal (1, 2) monitors the payee's terminal's/base station's broadcasting/transmitting details or the payer by sending a message requests the payee's terminal (2) or host computer (4) to send the required information such as payee's details, bill format etc. needed to perform the purchase or bill payment. Then the payer can enter the required information, if necessary, such as transaction's amount and send the bill (either including the required telecash or without it) to the payee's account which can be in the payee's terminal/MWP (2) or in the host computer. If the bill/payment is sent to the host computer (4), the host computer either transfer the received telecash to the payee's account or debit the payee's account for the amount which should be paid to the payee's account. Then the payee's/payer's terminals are acknowledged about the completion of the payment by sending message to both terminals. The user's account or contact numbers/codes can be a telephone number or a contact code allocated for user in order to receive and send bills and payments. The user's account or contact numbers/codes can be same as his telephone number or internet address used for sending and receiving bills and payment messages according to this invention. Alternatively, a different code or number can be used for this purpose. User can have a different user data in SIM 1

registration and authentication into his terminal or host computer or network's components (e.g. HLR, AuC) for the inventive payment service, or the same user data used for telephone services can be used for user registration or authentication, if required.

When the user does not want to perform purchase transactions, bill payments, exchange or transfer telecash, the terminal (1) can be used only as a telephone i.e. the MWP operates only as a mobile phone for example by activating a required function (for example "log-out" from the wallet-mode or "close the wallet" or by activating an icon presenting a wallet shown on the corner of the terminal's display). Therefore, if the terminal is stolen, its' owner should not be worried about his money or account since only the authorized user has the required P-PIN code in order to use his mobile phone as Mobile Wallet-Phone.

FIG. 3 shows one embodiment of the present invention in a service provider's environment. The service provider's base stations or terminals (2) or host computer (4) broadcast or send whenever required the payee's/service provider's details, bill format, bill, the sum which should be paid by payer and other required information for performing the payment. Alternatively the above-mentioned information can be requested through the payer's terminal (1) by sending a message to the payee's terminal directly or through the network/base stations or they can be requested from the host computer. The payee's details can include payee's account number, contact code (such as .PizzaHut.com), the service provider's cash register's number (i.e. contact code, account number etc.). The required information is then monitored (6) by the payer's MWP (1). Then the payer activates the payee's details upon which MWP sends the required payment/bill to the payee's account kept in payee's terminal (2) (SIM card) or in the host computer (4).

FIG. 4 presents another example of the payment method according to the present invention. The payer's MWP (1) monitors the payee's/service provider's details transmitted/broadcast over the air interface in a connectionless way (payer does not need to contact the payee). After that the payer has activated the required command for example "service provider" (or a number or button) his MWP monitors the available service providers' details. Monitoring of the service provider's details depends on the radio coverage of the service providers' base stations/terminals and payer's MWP's radio coverage area. For example service provider's terminal /base station (2) can broadcast/send the required information in a 1 to 5 meter (or more or less) configured radio coverage area (which can be adjustable). When the payer's MWP is under such coverage, it can receive the service provider's/payee's details. The required coverage can be adjusted for example from 1 millimeter to few meters or more (depending on the application). In this way only the payer and payee can exchange information, payments without using the network. Furthermore a signaling protocol can take place between the terminals for precise terminal to terminal communication. According to this embodiment of the present invention the exchange of information and payments takes place terminal-to-terminal which is the most secure option. However, when the payment (telecash) is transmitted from the payer's terminal (1) to the payee's terminal (2), the payee can send the payment to the host computer to the payee's account.

On the other hand when payer's terminal (1) monitors the payee's details and the payable bill and payer activates the payee's details (6), the bill (either together with the required amount of telecash or without it) can be sent via network to the host computer (4) where the payer, payee have accounts.

Then the payer account is debited for the amount of the bill and then payer's and payee's terminals are acknowledged about the completion of the transaction or the lack of money (credit) in the payer's account. In this way payee's and payer's terminal first exchange information in order to know to which account the payment should be transferred. Then after receiving the payee's details by the
5 payer's MWP (1) the network can be used to send the bill and/or required amount of telecash to the host computer (4), when required.

FIG. 5 presents four examples for payments in the service providers' environment. In example 1 the payee's terminal (2) broadcasts/sends the payee's details, bill (and purchase details if required) through the base stations (either payee's base station 2 or for example a GSM operator's base station
10 3) to the payer's MWP (1). The base stations can include the required controlling systems or they can be linked to the base stations' subsystem for controlling the base stations. Then payer activates the payee's details (account number) which also includes contact codes of the required host computer (e.g. www//OKObank.PizzaHut.fi or for example 3589435634528349). Then the bill and other required information is send to the host computer (4) where the required amount is transferred to the
15 payee's account.

In example 2 of FIG. 5 the payee's details, payable bill and other required data are directly broadcast/sent from the payee's terminal (2) to the payer's MWP (1). Both terminals (1, 2) are under each other's radio coverage so that the information broadcast/sent by payee's terminal is received by payer's MWP (1) without using the network (3). After this, the payer activates the payee's details,
20 as explained above, and sends the bill to the host computer. In example 3 of FIG. 5 the service provider's details, for example, the gas station's or a bus company's account number, codes or other required information such as the price of petrol per litter or the price of ticket are broadcast/sent to the payer's terminals (1). For example when payer wants to pay for petrol, he activates the service provider's details received by his terminal (1) and sends it to the host computer (4), then the host
25 computer checks the payer's account and sends a message to the petrol station's terminal (2) indicating that the payer has the right (sufficient credit) to buy the petrol. After that payer has finished tanking his car, the terminal (2) sends the bill to the host computer (4) for debiting the payer's account for the amount of the petrol he has bought. Then the host computer (4) sends an acknowledgment message to both terminals (1, 2) indicating that the payment has been completed.
30 On the other hand if the payer pays by telecash (electronic money), he can by activating the service provider's details (account number) send the amount (for example 10 dollars) to the petrol station's terminal (2) or host computer (4) which after the payer have the right to tank his car against 10 dollars paid. The payment can be paid in different ways but according to this invention user's MWP (1) receives the payee's details (account number, contact codes) directly from the payee's terminal
35 (2) or via the base stations/network, and then activates the payee's details, upon which, the required telecash, bill is sent to the payee's terminal (2) or his account in the host computer (4). All automatic selling machines, gas stations (and other retail registers etc.) can be integrated with a wireless/cellular transmitter and receiver to provide a wireless/cellular payment service, in accordance with this invention, so that users can pay for their purchases and required services by
40 using the inventive Mobile Wallet-Phone in a user friendly way without any need to establish a call or to use conventional money or different credit or debit cards. For instance the example 4 of FIG. 5

shows the automatic coffee machines (coffee maker and other automatic seller machines which are equipped with the inventive terminal (transmitter- receiver 2) to send the service provider's (the coffee seller machine) details and the coffee's price, for example continuously or whenever the customer appears in front of the machine or activates a button on the machine. Then the customer
5 (payer) activates the received payee's (the coffee seller's) details in his MWP and sends the bill (accepted price) or the required telecash to the coffee machine's terminal (2) or to the host computer (4) to be transferred to the payee's account. Then after that the payment has been completed, the coffee machine offers a cup of coffee to the payer. Any other service can be paid in a same way as above-mentioned examples or other alike procedures by using inventive method and terminals (1, 2),
10 and when required, base stations (2, 3), host computer (4) and the network (3).

FIG. 6 shows a top view of the user's Mobile Wallet-Phone (MWP) in accordance with one embodiment of this invention. In one embodiment of this invention user activates the command "payments" which after the MWP prompts the user to enter the P-PIN code "Enter P-PIN". After that, the user's device (for example mobile telephone, pager etc.) becomes a MWP by which the user
15 can perform purchase and bill payments and send/receive telecash. In another embodiment of this invention when the user activates a command for example "service provider" the MWP listens to the radio interface (available base stations/other terminals) or requests the network/host computer (3, 4) to send the service providers details (account number, codes etc.) and when needed the bill or bill format which after the MWP (1) monitors the details on its screen (6) for the user. The service
20 provider also sends (whenever required) the bill which should be paid by the payer. The payer can then activate the service providers details and send a message, bill or the required amount of telecash to the host computer or the payee's terminal.

The user P-PIN code can be changed using the same method which is used in mobile phones to change the PIN code. According to the invention the user's terminal/smart card (SIM) includes the
25 required software (or the required software can be down-loaded to the terminal whenever needed) for the process of P-PIN entering and authentication.

The user's MWP (1) can be made in different shapes and sizes. For example, the user's watch can be integrated with a wireless message receiver (pager) and transmitter which can be used for performing user's payments by using the inventive method. For example at a cash register when the
30 customer wants to pay for his shopping, the bill (the sum to be paid) can be received by the customer's watch. Then the customer can by activating the payee's details (contact and/or account codes and number) send the bill (with the required amount of telecash, if required) to the shop's cash register (terminal 2) or host computer.

The payment method presented in this invention can be based on an open platform and can be
35 used in different terminals (mobile phones, pagers etc.) and implemented in different scales. Furthermore, for example all products in shops can be labeled with a tag/card which transmits/radiates the product's details such as name and price, and the service provider's (for example the shop keeper's) account number continuously so that when the user's MWP's antenna is quite near to the mentioned card/label or when the tag/card is touched by said antenna then the user's
40 MWP receives the required information, as mentioned already. In this way the user can collect all his needed goods and their information in his MWP, and then send the payment/bill to the host

computer (4) or payee's terminal (2). Therefore, there will be no need for the existing cash registers. The cashiers' work can be directed to advice the customers (for finding the needed products etc.) thus providing a better quality service rather than sitting behind the cash register desks and doing a boring job.

5 In accordance to one embodiment of this invention the transmitting/broadcasting of the payee's/service provider's details can be a location-based action. For example when the payee's and payer's terminals are in the range of each other's radio coverage, they can monitor each other's details (the user's account number, codes etc.). On the other hand the location of the payer can be located when the payer's terminal is under the radio coverage of the payee's terminal/base station, for
10 example, when the payer is under the coverage of the base station of a petrol station, the required signaling can take place between the user MWP and the petrol station's base station system so that the base station system notices that a user is coming to get the service. Then the base station can send/broadcast the required information to the user's terminal. The location defining can be also taken place without any signaling between the terminal and base stations. The location positioning
15 can be a cell-based or an exact location positioning option. When the user's MWP is under the service provider's terminal/base stations radio coverage, the user's MWP can monitor the service provider's terminal's/base station's transmitting/broadcasting information, including the payee's details (account or contact codes and number, charging details etc.). For example FIG. 7 and 8 presents a flow chart of a parking system where the parking service provider's base station
20 transmits/broadcasts charging information, parking zone details and other required information based on the city's different zones/areas. The user can then activates the service provider's details under a command "parking" which is monitored by his mobile terminal (or is stored in his mobile terminal or its SIM card) and if required enters the parking zone number (if the zone number is not sent by the base stations or the host computer) into his terminal and sends the message to the host
25 computer for getting the right to use the parking space. The charging can be an account-based or telecash-based option so that when the user collects his car from the parking space a message (including also the required amount of telecash, if needed) which can be any message is sent by his mobile terminal to the parking data base where the user's account is debited or the received telecash is transferred to the service provider's account. The parking time can be counted in the user's
30 terminal (for example after receiving an arrival acknowledgment message from the host computer) or in the host computer, depending on either the user pays for his parking by telecash or his account must be debited.

FIG. 9 presents two Mobile Wallet-Phones which are able to configure an adjustable radio coverage within which, they can send and receive their users' details (account number, codes etc.)
35 and the required telecash. The MWP's radio coverage for this purpose can be adjusted within a range of, for example, few millimeters to few meters or more. When for example the payer's MWP (1) is in the payment mode (which means the terminal is operating as electronic wallet and is able to send and receive the required account number and telecash) the user can send the required amount of telecash to the payee's MWP (2) or to the payee's account in the host computer. For example, when the
40 payer's MWP (1) receive the payee's details, he can enter a number equal to the required amount of telecash (for example 10 dollars) he wants to pay to the payee then by activating the payee's details

the terminal (1) sends the required amount of telecash to the payee's MWP (2) or to the host computer. The payee can send also the bill, required to be paid by the payer, to the payer's MWP (1). In that case the payer does not need to enter anything in his MWP but just accept the bill and send it to the payee's terminal or the host computer.

5 In accordance to another embodiment of this invention the payer sends a message (any message, for example an empty short message, including a letter for example) to the payee's terminal (whenever the payer activates the contact number/codes or account number of the payee) in order to receive the bill. For example when the customer is near the cash register he can enter the cash register's contact number into his MWP or his MWP monitors the cash register's terminal's (2)
10 broadcasting contact number. Then the message is sent to the cash register's terminal and indicates who is the message sender because the message includes the senders details (contact number). The message sender's contact number can be sent directly from the sender's MWP or from the network (for example short message center, switches or other network component) or from the host computer (for example the shop's host computer via which the message goes to the cash register's terminal, and
15 wherein the payer can have an account). Then cashier activates the payer's contact codes (by activating "Send" button, for example) upon which the bill or the sum to be paid by the payer is sent to the payer's terminal. Then the payer activates the payee's account or contact codes or the host computer's contact codes which after the bill (sum to be paid) and/or the required telecash is sent to the payee's terminal or the required host computer (located in the service provider's service area or in
20 the bank or in the network). Then the telecash is transferred to the payee's account (if it is not sent directly to the payee's terminal) or the payer account is debited. If the terminal-to-terminal payment is not taken place, that is, the payment is completed in the host computer, then the host computer sends the required messages to the payee's and payer's terminals to acknowledge the completion of the payment.

25 In this invention the users terminals (1, 2) can operate as the switches and base stations to each other since in one embodiment of this invention said terminals can transmit to each other any required information without using the network. Therefore, the network's capacity is not wasted when users are near to each other (as usually for example to pay in the shops the payer is near to the payee). Depending on the air interface protocol used for terminal-to-terminal communication, for
30 (short) messaging terminals (1, 2) do not necessarily need to have any signaling or be synchronized. But when required terminals (1, 2) can have required signaling and if required be synchronized. For example payer's terminal (1) listens to the air interface and receives the signals for example from payee's terminal (2). Then the communication between the terminals can be synchronized (in case of CDMA systems, synchronization is not necessary; CDMA: Code Division Multiple Access) on
35 terminal-to-terminal basis without using the network. Then payer's terminal (1) can transfer the information received from the payee's terminal (2) to any other terminal either directly or via network.

The users' MWPs can at the same time operate as the user's mobile phone and electronic wallet. For example the terminal can be a dual-mode or a single-mode (dual-band), for example a GSM-
40 DECT dual-mode terminal that in accordance to this invention can operate so that when user is shopping the DECT part of the terminal operates as user's wallet for purchase payment, and the

GSM part for telephone calls. The term GSM stands for Global System for Mobile Communication, the term DECT stands for Digital European Cordless Telecommunications. The terminal (1, 2) can operate both in a wireless local loop and under the wide area wireless networks. The user's purchase payments, bills, telephone calls and all kind of payments can be paid by his MWP. By utilizing this invention there will remain no possibility to produce false money, because user does not need to use any conventional money, since the user's MWP acts as his empty wallet without any conventional money. The user's smart card can be a separate card or his SIM card which can be reloaded with the required amount of telecash. On the other hand user's money can be only kept in his account and the required bills be sent to the host computer (4) where the payer's account can be debited. In this invention the user can be both the payee and the payer. The user can reload his smart card/terminal over the air interface with the required amount of telecash. For example user can transfer the required amount of electronic money (telecash) from his account in the host computer (4) to his terminal's (1) smart card whenever required. In this invention in order to load the user's terminal's smart card with the required telecash any communication protocols (either packet switched or circuit switched means) can be used. In this invention the payee's/service provider's details (account number, codes, contact codes) can be broadcast/sent to all or a group of users (terminals 1) or to the required terminal, which are roaming under the radio coverage of the payee's/service provider's base station or terminal (2) or the network's base station (3).

In this invention the user's MWP (1) uses the wireless/cellular digital communication messaging means without using any modem for communication between the users' MWPs and host computer, network or other terminals. The terminal (2) can be also a fixed or portable terminal such as personal computer or television using both wireless and internet networks. The inventive method can be used in both wireless and internet networks.

The users' terminals (1, 2) can be used in any wireless/cellular network such as GSM, PCS, DCS, CDMA, DECT, PHS, ERMES, FLEX and internet. The user's details and payment messages can be send via messaging means of wireless networks such as short message or paging networks, and via internet or via signaling means of networks and MWPs. The user's MWP can be any standard mobile phone and pager by which the inventive method can be utilized. The host computer (2) can include the users' data and accounts or be connected to the users' bank accounts or be logically integrated into any component of the network (3). The user data, for registration and authentication in the terminal or into network or host computer can be the same as the user subscription data (if users use subscription related services, and if required). For example if the telecommunications services are subscription free then the user authentication can take place only between the user, his smart card and terminal. The user can pay for his telephone calls while he is on move (pay-as-you-go) or per each call.

The described embodiments of the invention are only considered to be preferred and illustrate of the inventive concept, the scope of the invention is not to be restricted to such embodiments. Various and numerous other arrangements may be devised by one skilled in the art without departing from the sprit and scope of this invention.

It is therefore intended by the appended claims to cover any and all such applications, modifications and embodiments within the scope of the present invention.

What is Claimed Is:

1. A wireless/cellular terminal, preferably a SIM operated mobile phone for operating as the user's Mobile Wallet-Phone (MWP) for allowing a user to perform remote purchase payment and remote bill payment transactions with a remote host computer or other terminals, the terminal comprising:
- 5 means for receiving, handling and transmitting the user's details, account number, contact codes and number, bill, the required amount of telecash to other terminals directly without using the network or via base stations or via any wireless/cellular and/or internet network;
- means for sending, receiving and/or broadcasting the required data to/from other terminals
- 10 directly under the coverage of said terminals without using the network;
- means for configuring an adjustable radio coverage within which said terminal can send, receive and/or broadcast data to/from other terminals or host computer without using the network;
- means integral to the terminal for operating the terminal, receiving and monitoring payee's/service providers' details, account number and codes, contact number and codes, the required
- 15 bill and bill format;
- means integral to the terminal and coupled to the terminal's control means for receiving and sending the required amount of telecash directly from said MWP to other terminals or MWP;
- means integral to the terminal for operating, when required, as a wireless/cellular terminal and when required as a cordless terminal;
- 20 means integral to the terminal for making mobile/cordless telephone calls;
- a smart card reader integral to the terminal, if user uses smart card;
- means for reloading the user's smart card with the required amount of telecash;
- a display integral to the terminal;
- a digital camera means integral to the terminal, if the user wants the purchasing product's or the
- 25 bills details to be read by a camera;
- when used for service providers, the terminal further includes interface means for connecting the terminal to the service provider's automatic machines (petrol stations, coffee machines and any other kind of automatic seller machine).
- 30 2. The terminal of claim 1 further comprising:
- means for prompting the user to enter a personal identification number for payments, P-PIN, which can be same as the user's PIN for mobile telephone services and can be entered after that the PIN for accessing to the telephone operating network is entered, and that after entering the P-PIN said terminal can be used as the user's electronic wallet, MWP;
- 35 means for encrypting the entered P-PIN, which can be same as the encrypting means used for encrypting the PIN code for mobile telephone services;
- means for conveniently monitoring the broadcasted/received payee's details, account number and codes, contact number and codes, bill, bill format and means for sending the received details and when required the needed amount of telecash to the remote host computer or other terminals or
- 40 MWP;

means for direct communicating with other terminals or MWP's and/or host computers without using modem in or in conjunction with said MWP, and in a connectionless way via wireless messaging means of said MWP and when required via wireless messaging means of the network without establishing any circuit-switched call.

5

3. The terminal of claim 1 or 2 further comprising:

means for controlling display to conveniently display the broadcasted/received payee's details, name and account number, contact codes and bill to the user;

means for the user to conveniently select and activate the broadcast/received payee's details,
10 account number, contact codes for sending said data and when needed, the required amount of telecash to the payee's terminal or the host computer;

means for receiving the payee's details, account number, contact codes, based on the location of the payer's and payee's terminals or base stations;

means for terminal-to-terminal signaling, whenever required;

15 means for conveniently arranging the broadcasted/received payees'/service providers' details in an appropriate order to be selected and activated by payer for sending the bill and/or telecash to the payee's terminal or host computer;

means for controlling the means for reloading the smart card with the required amount of telecash and means for spending the required amount of telecash for shopping, purchasing and bill payment;

20 means for controlling the digital camera integral to the terminal, if the user wants the purchasing product's or the bill's details to be read by the camera.

4. A method for allowing a user to perform purchase and bill payment transactions with other remote terminals or remote host computers, the method comprising the steps of receiving the
25 **payee's/payee's, details including account number or codes or contact codes and when required the bill or a bill format in a connectionless way without establishing a circuit-switched call, by a terminal having integral to the terminal a smart card reader, means for reloading the user's smart card with the required amount of telecash, a display, means for controlling and handling the information, each received bill format comprising fields as Amount:, Account no:, Due date:, and other required**
30 **fields already filled in when received by the payer's terminal or to be filled in, and that by activating the payee's or the host computer's account number or contact codes the bill and, when needed, the required amount of telecash are sent to the payee's terminal or to the host computer directly without using the network or via network.**

35 **5. The method of claim 4 further comprising the following step as much as needed and when required in a different order:**

promoting the user to enter a personal identification code (P-PIN), if the user uses a smart card (as SIM) which can also be reloaded with the required amount of telecash, and if the user activates the required command (payments) in his terminal;

40 encrypting the entered personal identification number;

receiving the payee's terminal's, base station's, transmitter's, product's tag's/card's or the host

computer's transmitting/broadcasting details, or reading the product's bar codes by means of a digital camera integral to said terminal, and monitoring said details on the display of the payer's terminal as much as required, or

prompting the user to activate a function ("payee" or "service provider" or "payments" or any other alike command) which after activation said payer's terminal monitors the payee's terminal's/base station's or host computer's or other sources (product's tag's/card's) transmitting/broadcasting payee's (and product's) details or said payer's terminal requests said payee's terminal or a host computer to send the bill, bill format, payees details, account number, codes;

10 connectionless communicating with the remote host computer or the payee's terminal to send the bill, and when needed the required amount of telecash, to the payee's terminal or the host computer without establishing any circuit-switched call, and that the communication with the remote host computer or payee's terminal can take place both via internet or messaging means of any wireless network or directly between the payer's and payee's terminals or the host computer without using the
15 network.

6. A method for allowing a user to perform remote purchase and bill payment transaction with other remote terminals or remote host computers, and sending and receiving data, the method comprising the step of controlling and configuring an adjustable radio coverage by means integral to a terminal
20 having wireless/cellular messaging means for transmitting, receiving and handling the data without using modem, and that said radio coverage can be adjusted by means integral to said terminal in order to configure a radio coverage area within which the payee's and payer's terminals and/or host computer can exchange required information, send and receive information without using the network; and that:

25

for service providers the terminal is further connected or integrated into the automatic machines (petrol stations, coffee machines and other required automatic sellers) of the service providers so that whenever required or continuously the terminal broadcasts/sends the service provider's details, account number, contact codes, the bill, the price of the service and other required information to the
30 payer's terminals (MWP) for performing the payment.

7. A method according to claims 4-5 for sending and receiving purchase transactions and bill payment and that said method is used both in wireless/cellular terminals and also in personal computers and televisions using internet, the method comprising the steps of:

35 requesting, by means of the payer's terminal, the host computer or other terminals to send the bill, bill inquiry (format) and payee's details to the payer's terminal;

displaying the received bill or bill inquiry for the user;

acceptance of the bill or entering the required data into the bill inquiry by user and activating the required function to send the bill to the host computer or other terminal, or:

40 the method comprising the steps of:

broadcasting by means of payee's terminal or base station the payee's, and when required the

purchasing product's details, over the air interface for all or a group of payers' terminals;

activating the payee's and/or product's details (account code, contact number) in the payer's terminal and sending the bill, with the required amount of telecash when needed, to the payee's terminal or to the host computer.

5

8. A method for allowing a user to perform purchase and bill transactions with other remote terminals or remote host computers, the method comprising the steps of:

sending a (short) message to the payee's terminal, said message including the payee's contact number/codes when received by the payee's terminal;

10 sending the payable bill or a notification of the sum which must be paid by the payer to the payee to the payer's terminal using the payer's contact number/codes already received;

sending the required amount of telecash from the payer's terminal to the host computer or to the payee's terminal, or sending the bill with or without the amount of telecash to the host computer;

15 debiting the payer's account for the payee, if the required telecash has not been sent to the payee's account.

9. A system for allowing a user to perform remote purchase payment transactions with other remote terminals or remote host computer, the system comprising:

a wireless/cellular terminal (MWP) comprising:

20 means for receiving, handling and transmitting the users' details, account number, contact codes and number, bill, the required amount of telecash to other terminals directly without using the network or via base stations or via any wireless/cellular and /or internet network;

means for sending, receiving and/or broadcasting the required data to/from other terminals directly under the coverage of said terminals without using the network;

25 means for configuring an adjustable radio coverage within which said terminal can send, receive and/or broadcast data to/from other terminals or host computer without using the network;

means integral to the terminal for operating the terminal, receiving and monitoring the payee's/service providers' details, account number and codes, contact number and codes, the required bill or a bill inquiry;

30 means integral to the terminal and coupled to the terminal's control means for receiving and sending the required amount of telecash directly from said MWP to other terminals or MWP;

means integral to the terminal for operating, when required, as a wireless/cellular terminal and when required as a cordless terminal;

means integral to the terminal for making mobile/cordless telephone calls;

35 a smart card reader integral to the terminal, if user uses smart card;

means for reloading the user's smart card with the required amount of telecash;

a display integral to the terminal;

a digital camera means integral to the terminal, if the user wants the purchasing product's or the bill's details to be read by the camera;

40 when used for service providers, the terminal further includes interface means for connecting the terminal to the service provider's automatic machines (petrol stations, coffee machines and any other kind of automatic seller machine).

10. The system of claim 9 further comprising:

- means for prompting the user via the display to enter a personal identification number (P-PIN),
- means for controlling the means for encryption to encrypt the entered personal identification number, if the user uses a smart card in or in conjunction with the terminal;
- 5 means for receiving, handling and displaying a bill inquiry, bills and payee's details and sending said data in a connectionless way to other terminals, personal computers and/or host computer;
- means for wireless, modemless and connectionless communicating with other terminals or host computer to send and receive the payee's details, contact codes, numbers, account number, bills, bill inquiry, required amount of telecash, directly without using the network or via the network;
- 10 means integral to the terminal for controlling and configuring an adjustable radio coverage area for wireless/cellular terminal-to-terminal or terminal-to-host computer communications without using the network, so that the payer's and payee's terminals can exchange information securely and without interruption of other terminals;
- means integral to the terminal for controlling and configuring an adjustable radio coverage area
- 15 which can be adjusted automatically or manually to a desirable range (1 millimeter to 1 meter or more or less);
- means for controlling the display to display the received payee's details, account number, contact number, bills, bill inquiry;
- means for the user to select and activate the payee's details for sending the bill or payment to the
- 20 payee's terminal or host computer;
- means integral to the terminal and/or network and host computer for defining the location of the terminal based on which the details of all service providers/payees which are near to the payer's terminal or are under the same radio coverage can be sent/broadcast to the payer's/payers' terminals;
- means for terminal-to-terminal transmitting, broadcasting, receiving of information without using
- 25 the network;
- means for broadcasting/transmitting the service provider's/payee's details, account number, contact codes from the service provider's/payee's terminal/base station to the payer's/payers' terminals;
- means for terminal-to-terminal communicating using wireless messaging communication without
- 30 using the network;
- means for communicating between the payee's and payer's terminals and/or host computer via messaging means of wireless/cellular networks (short messaging, paging and other such networks);
- means for controlling the means for reloading the smart card with the required amount of telecash and means for spending the required amount of telecash for shopping, purchasing and bill payment;
- 35 means for controlling the digital camera integral to the terminal, if the user wants the purchasing product's or the bill's details to be read by the camera.

FIG. 1

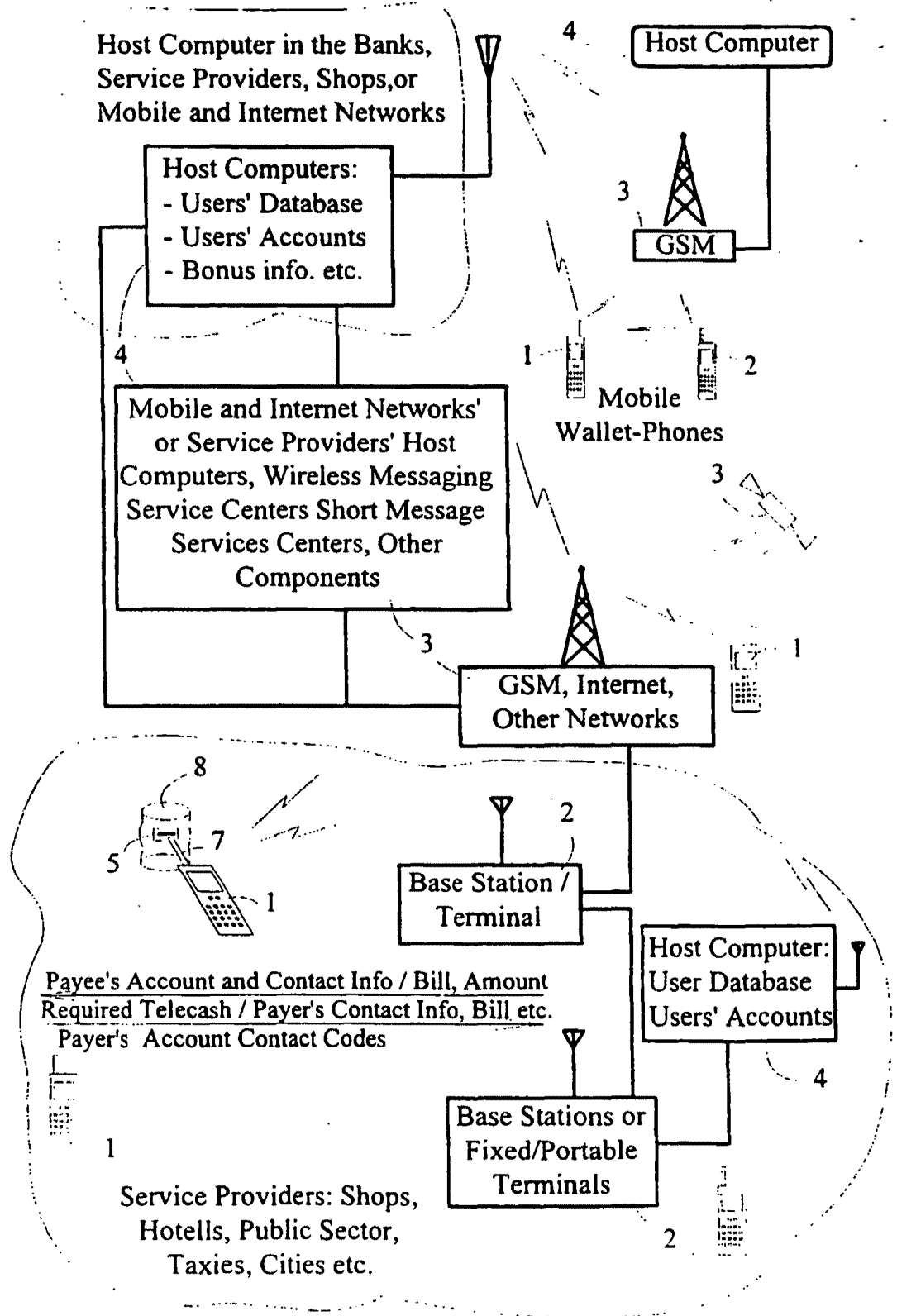

SUBSTITUTE SHEET

FIG. 2

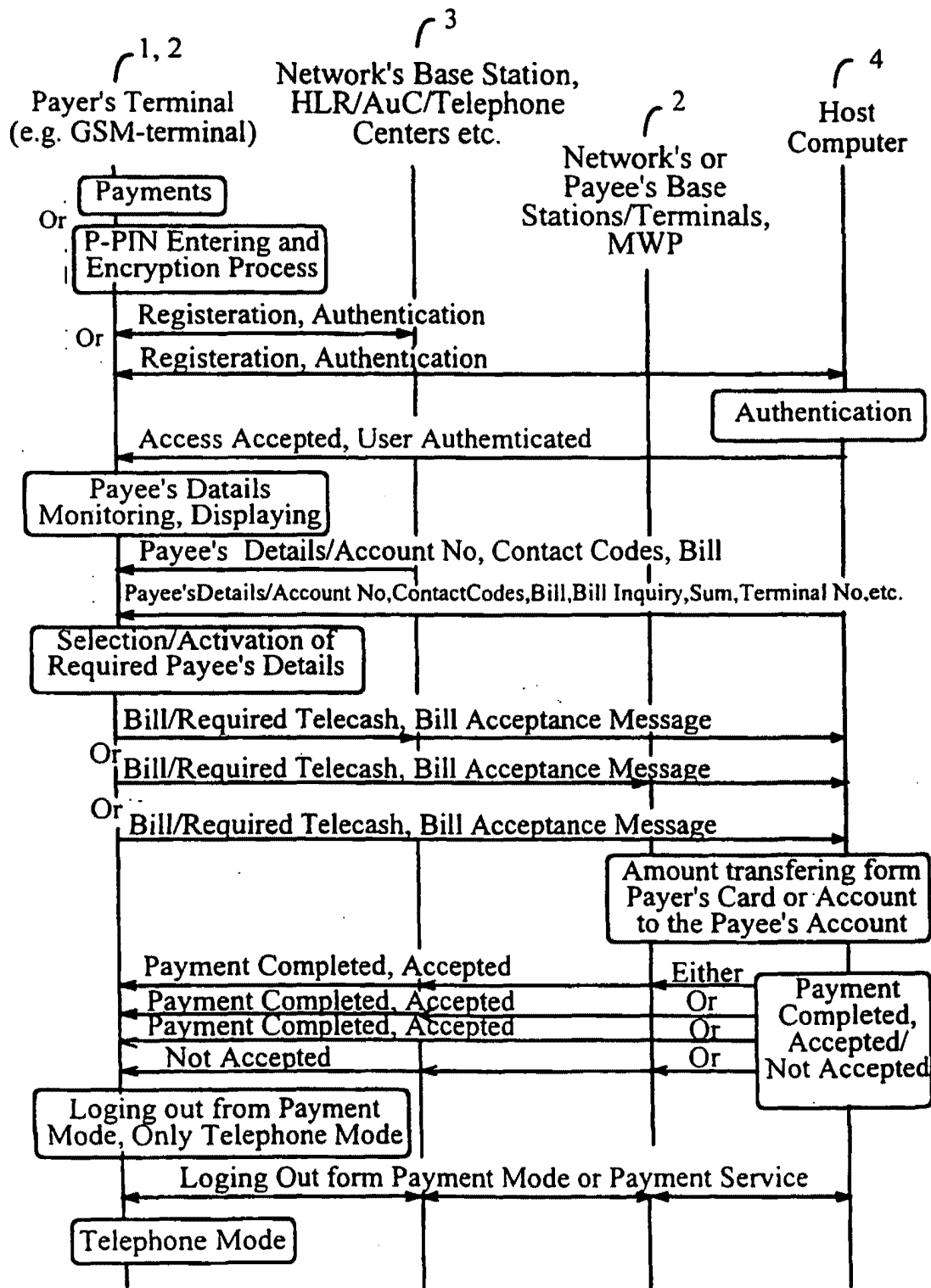

FIG. 3

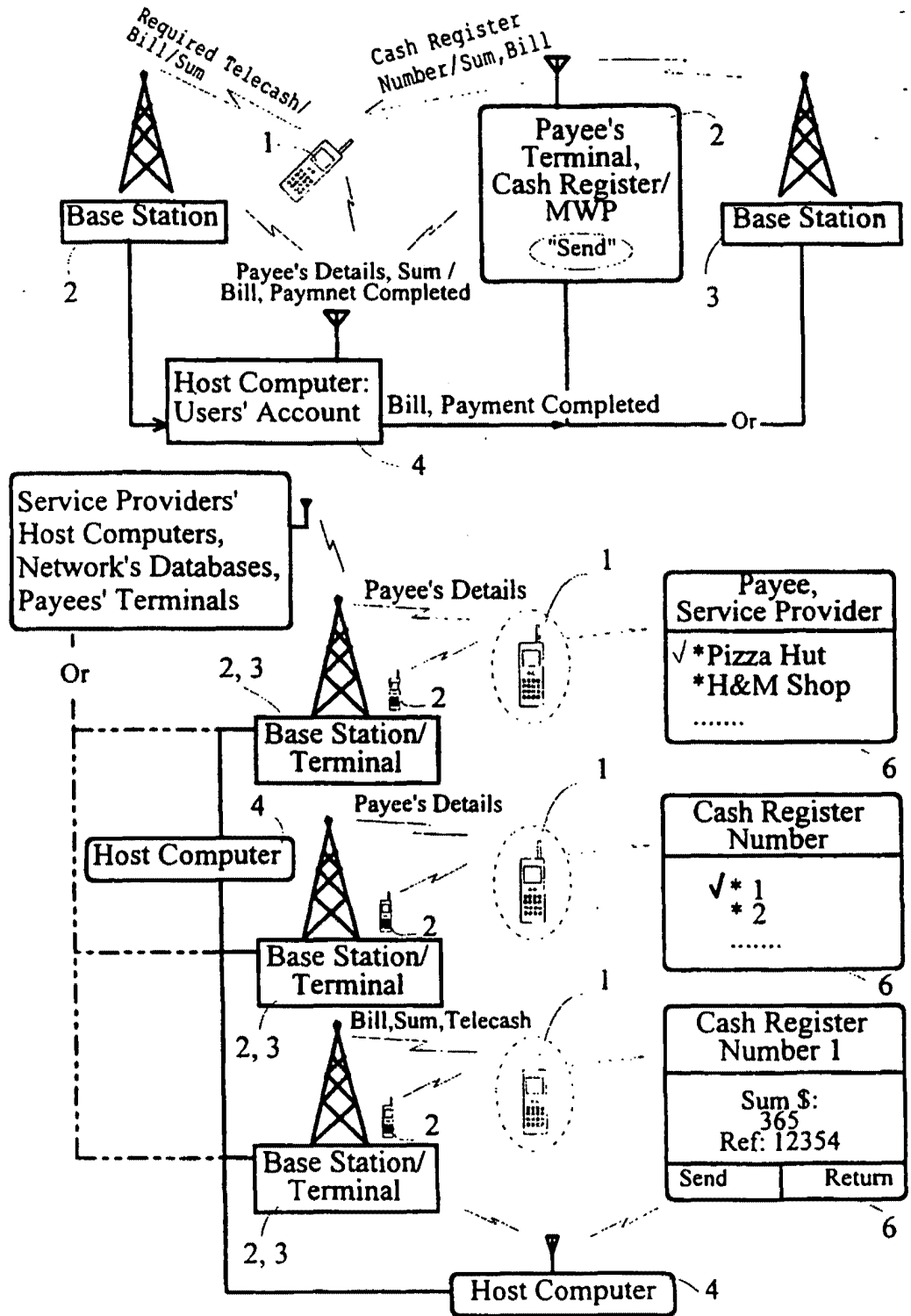

FIG. 4

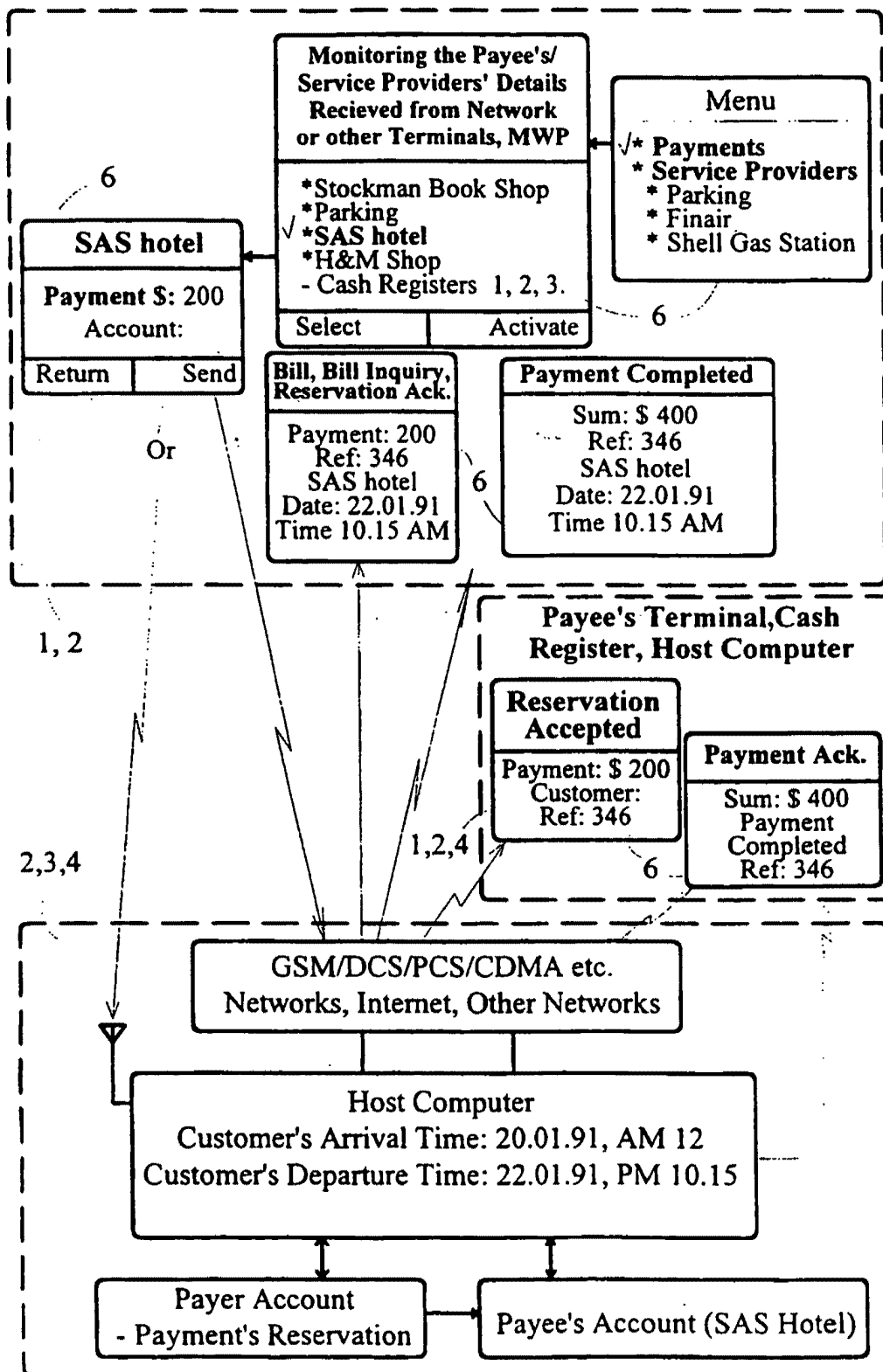
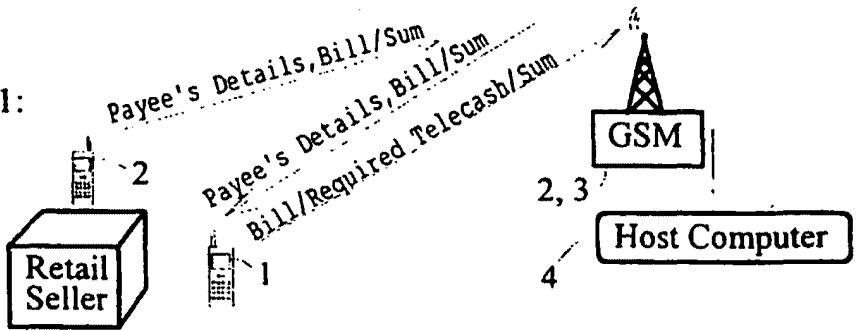
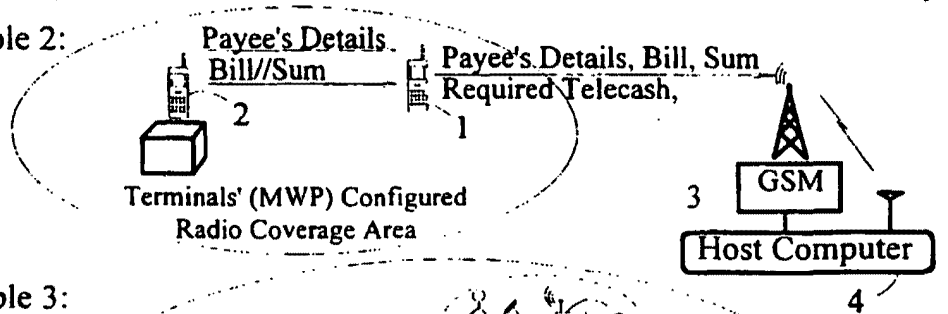

FIG. 5

Example 1:



Example 2:



Example 3:

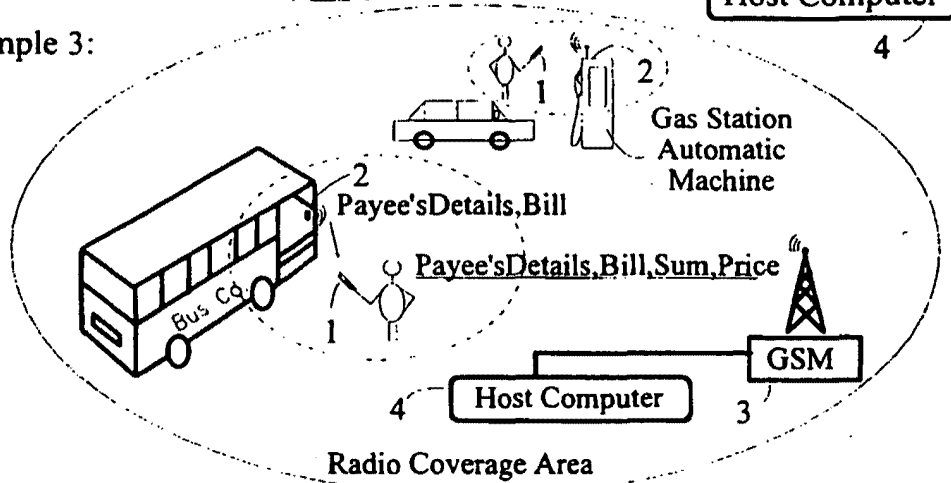

Example 4:

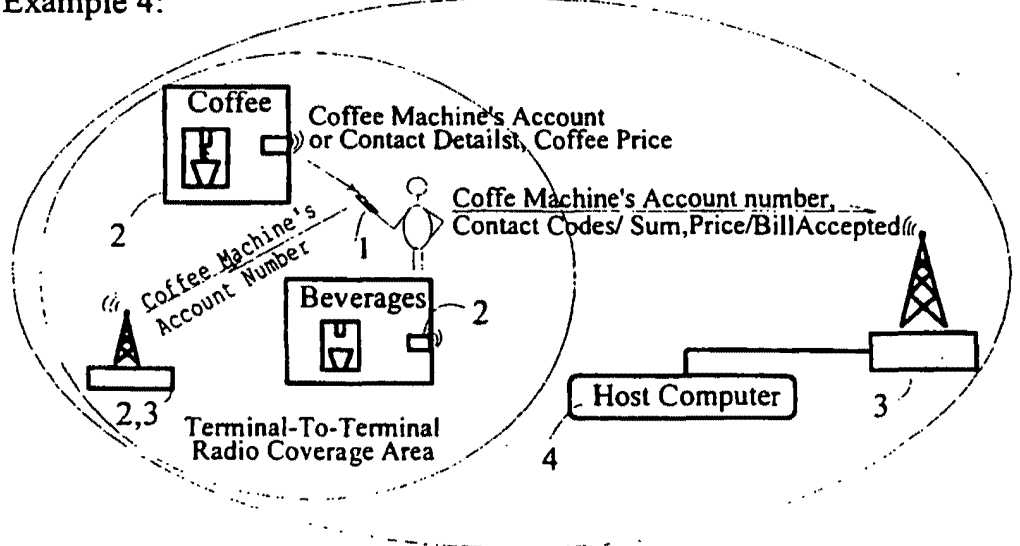

FIG. 6

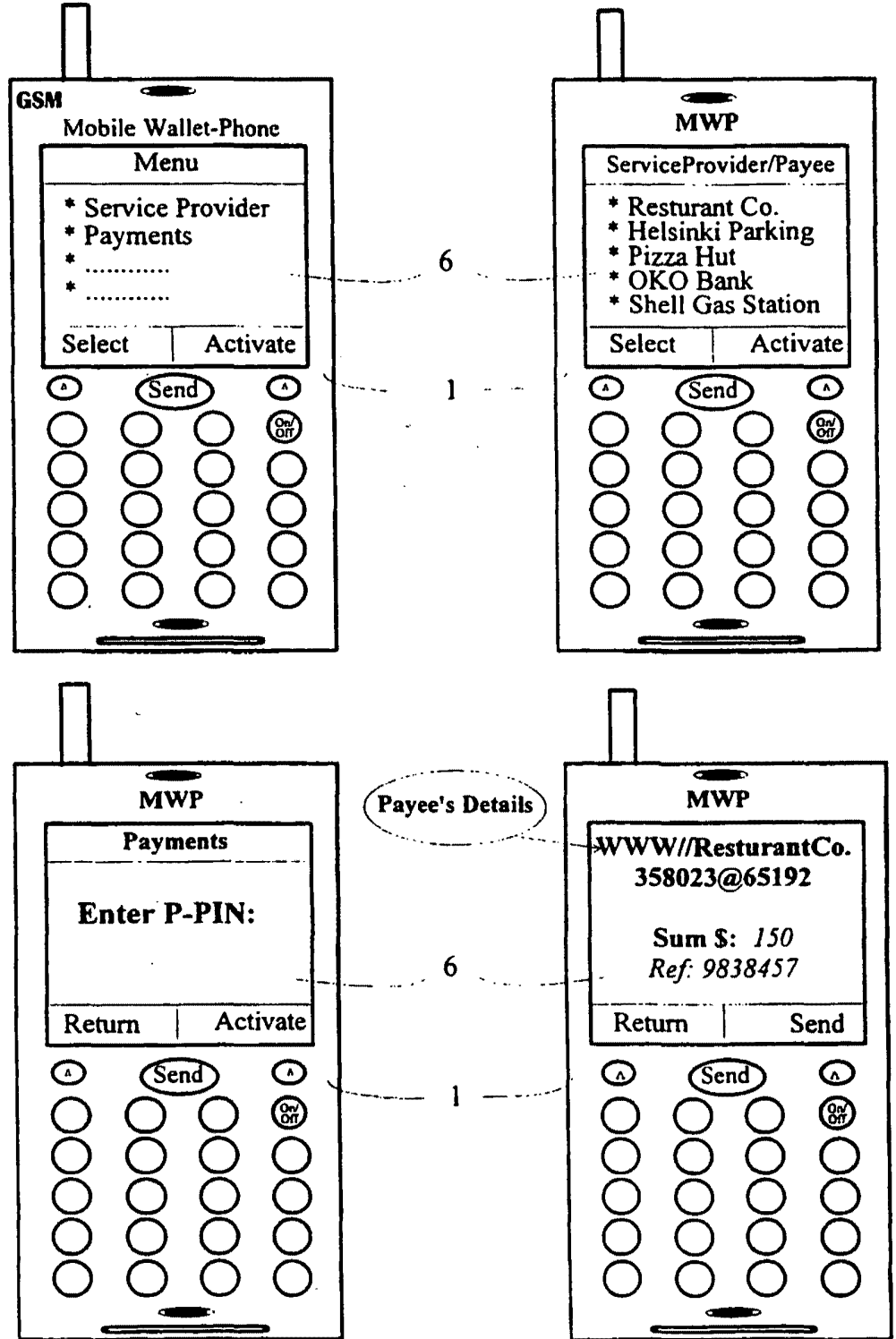

FIG. 7

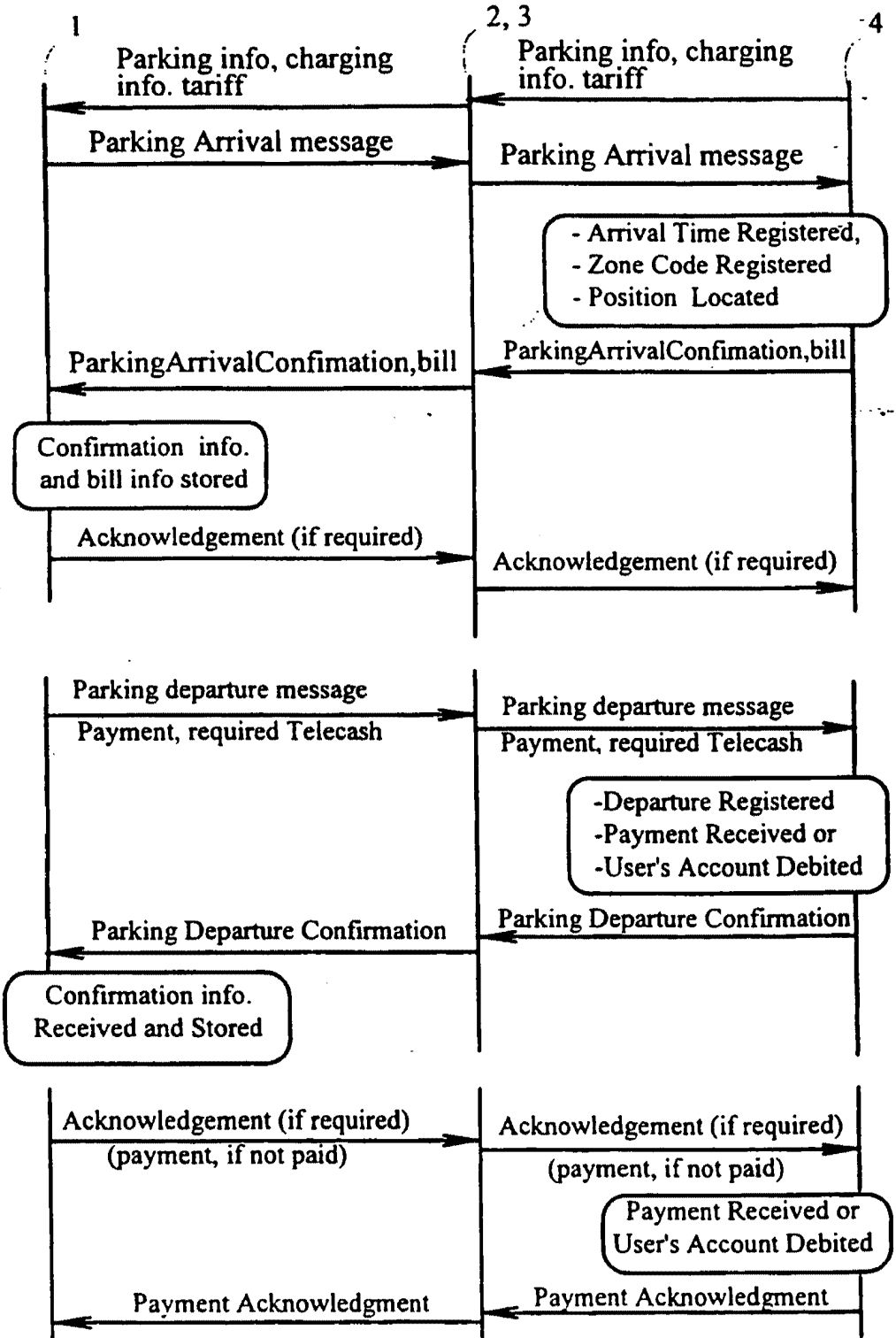
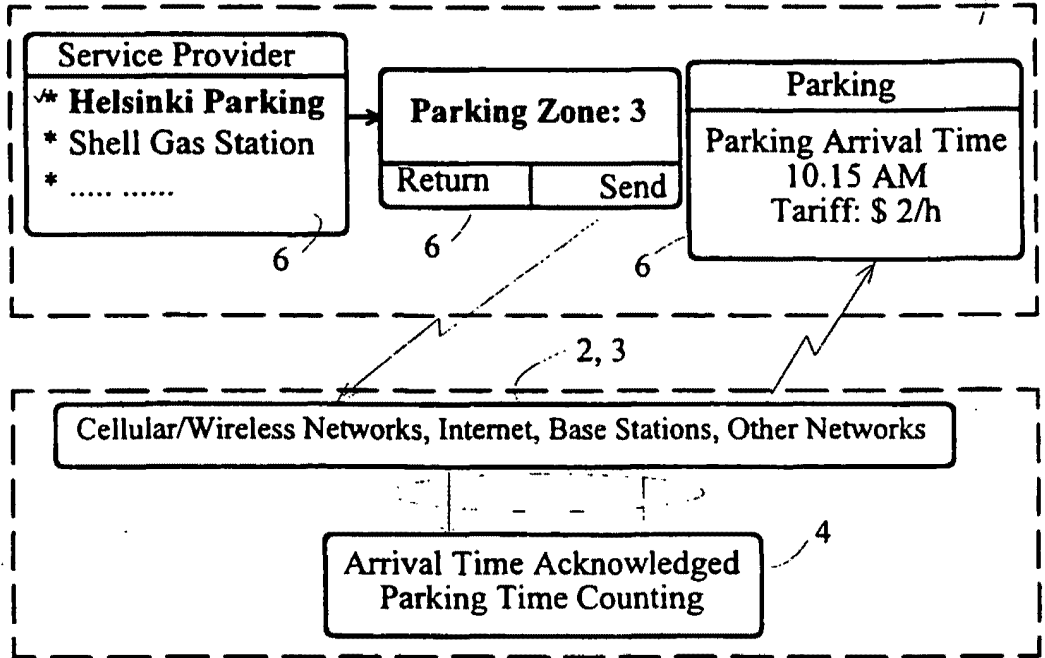

FIG. 8

Parking Arrival Messaging



Parking Departure Messaging

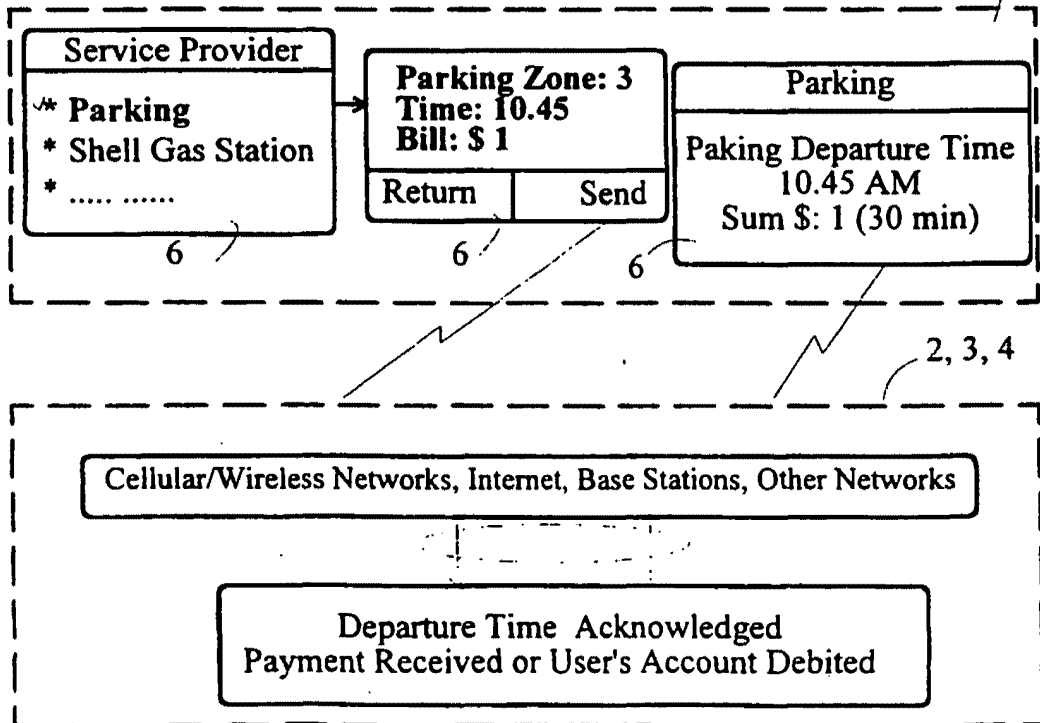
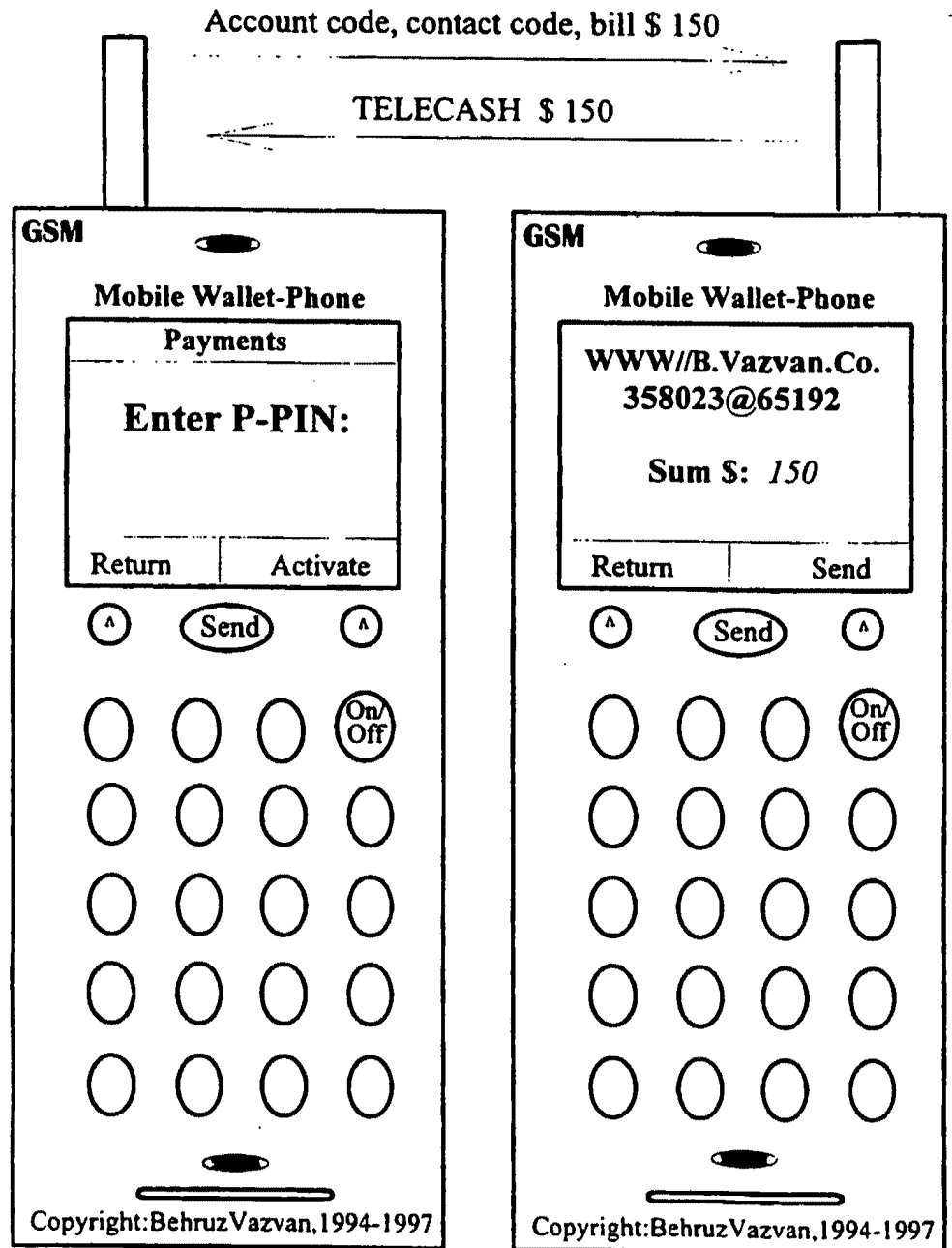

FIG. 9



INTERNATIONAL SEARCH REPORT

International application No.

PCT/FI 97/00315

| A. CLASSIFICATION OF SUBJECT MATTER | | |
|---|--|--|
| IPC6: G07F 7/08, G07F 19/00, G06F 17/60 // G06F 157:00 According to International Patent Classification (IPC) or to both national classification and IPC | | |
| B. FIELDS SEARCHED | | |
| Minimum documentation searched (classification system followed by classification symbols) | | |
| IPC6: G07F, G06F, H04Q | | |
| Documentation searched other than minimum documentation to the extent that such documents are included in the fields searched | | |
| SE,DK,FI,NO classes as above | | |
| Electronic data base consulted during the international search (name of data base and, where practicable, search terms used) | | |
| EDOC | | |
| C. DOCUMENTS CONSIDERED TO BE RELEVANT | | |
| Category* | Citation of document, with indication, where appropriate, of the relevant passages | Relevant to claim No. |
| A | WO 9613814 A1 (VAZVAN, BEHRUZ), 9 May 1996 (09.05.96) -- | 1-10 |
| A | WO 9411849 A1 (VATANEN, HARRI), 26 May 1994 (26.05.94) -- | 1-10 |
| A | US 5030806 A (THIERRY COLLIN), 9 July 1991 (09.07.91) -- | 1-10 |
| P,A | WO 9632700 A1 (AU-SYSTEM), 17 October 1996 (17.10.96) -- ----- | 1-10 |
| <input type="checkbox"/> Further documents are listed in the continuation of Box C. <input checked="" type="checkbox"/> See patent family annex. | | |
| * Special categories of cited documents: "A" document defining the general state of the art which is not considered to be of particular relevance "E" earlier document but published on or after the international filing date "L" document which may throw doubts on priority claim(s) or which is cited to establish the publication date of another citation or other special reason (as specified) "O" document referring to an oral disclosure, use, exhibition or other means "P" document published prior to the international filing date but later than the priority date claimed "T" later document published after the international filing date or priority date and not in conflict with the application but cited to understand the principle or theory underlying the invention "X" document of particular relevance: the claimed invention cannot be considered novel or cannot be considered to involve an inventive step when the document is taken alone "Y" document of particular relevance: the claimed invention cannot be considered to involve an inventive step when the document is combined with one or more other such documents, such combination being obvious to a person skilled in the art "&" document member of the same patent family | | |
| Date of the actual completion of the international search | | Date of mailing of the international search report |
| 5 November 1997 | | 05 -11- 1997 |
| Name and mailing address of the ISA/ Swedish Patent Office Box 5055, S-102 42 STOCKHOLM Facsimile No. +46 8 666 02 86 | | Authorized officer Jan Silfverling Telephone No. +46 8 782 25 00 |

INTERNATIONAL SEARCH REPORT
Information on patent family members

01/10/97

International application No.
PCT/FI 97/00315

| Patent document cited in search report | Publication date | Patent family member(s) | Publication date |
|--|------------------|-------------------------|------------------|
| WO 9613814 A1 | 09/05/96 | EP 0739526 A | 30/10/96 |
| | | FI 945075 A | 29/04/96 |
| | | FI 962553 D | 00/00/00 |
| | | FI 962961 A | 28/08/96 |
| | | FI 971009 A | 26/04/97 |
| | | FI 971248 D | 00/00/00 |
| | | FI 971848 A | 30/04/97 |
| WO 9411849 A1 | 26/05/94 | EP 0669031 A | 30/08/95 |
| | | FI 925135 A | 12/05/94 |
| | | FI 934995 A | 12/05/94 |
| | | NO 951814 A | 09/05/95 |
| US 5030806 A | 09/07/91 | EP 0345108 A | 06/12/89 |
| | | FR 2632101 A,B | 01/12/89 |
| | | FR 2639742 A | 01/06/90 |
| | | US 4992646 A | 12/02/91 |
| WO 9632700 A1 | 17/10/96 | AU 3943795 A | 06/06/96 |
| | | EP 0784715 A | 23/07/97 |
| | | SE 9501347 A | 12/10/96 |

**This Page is Inserted by IFW Indexing and Scanning
Operations and is not part of the Official Record**

BEST AVAILABLE IMAGES

Defective images within this document are accurate representations of the original documents submitted by the applicant.

Defects in the images include but are not limited to the items checked:

- BLACK BORDERS
- IMAGE CUT OFF AT TOP, BOTTOM OR SIDES
- FADED TEXT OR DRAWING
- BLURRED OR ILLEGIBLE TEXT OR DRAWING
- SKEWED/SLANTED IMAGES
- COLOR OR BLACK AND WHITE PHOTOGRAPHS
- GRAY SCALE DOCUMENTS
- LINES OR MARKS ON ORIGINAL DOCUMENT
- REFERENCE(S) OR EXHIBIT(S) SUBMITTED ARE POOR QUALITY
- OTHER: _____

IMAGES ARE BEST AVAILABLE COPY.

As rescanning these documents will not correct the image problems checked, please do not report these problems to the IFW Image Problem Mailbox.

(19) World Intellectual Property Organization
International Bureau



(43) International Publication Date
4 January 2001 (04.01.2001)

PCT

(10) International Publication Number
WO 01/01331 A1

- (51) International Patent Classification: G06K 9/00
- (21) International Application Number: PCT/US00/17157
- (22) International Filing Date: 21 June 2000 (21.06.2000)
- (25) Filing Language: English
- (26) Publication Language: English
- (30) Priority Data:
 - 60/141,538 28 June 1999 (28.06.1999) US
 - 60/141,763 30 June 1999 (30.06.1999) US
- (71) Applicant (for all designated States except US): DIGIMARC CORPORATION [US/US]; Suite 250, 19801 SW 72nd Avenue, Tualatin, OR 97062 (US).
- (72) Inventors; and
- (75) Inventors/Applicants (for US only): DAVIS, Bruce, L.

[US/US]; 15599 Village Drive, Lake Oswego, OR 97034 (US). RHOADS, Geoffrey, B. [US/US]; 304 S.W. Tualatin Loop, West Linn, OR 97068 (US).

(74) Agent: CONWELL, William, Y.; Digimarc Corporation, Suite 250, 19801 SW 72nd Avenue, Tualatin, OR 97062 (US).

(81) Designated States (national): AE, AL, AM, AT, AU, AZ, BA, BB, BG, BR, BY, CA, CH, CN, CU, CZ, DE, DK, EE, ES, FI, GB, GD, GE, GH, GM, HR, HU, ID, IL, IN, IS, JP, KE, KG, KP, KR, KZ, LC, LK, LR, LS, LT, LU, LV, MD, MG, MK, MN, MW, MX, NO, NZ, PL, PT, RO, RU, SD, SE, SG, SI, SK, SL, TJ, TM, TR, TT, UA, UG, US, UZ, VN, YU, ZA, ZW.

(84) Designated States (regional): ARIPO patent (GH, GM, KE, LS, MW, MZ, SD, SL, SZ, TZ, UG, ZW), Eurasian patent (AM, AZ, BY, KG, KZ, MD, RU, TJ, TM), European

[Continued on next page]

(54) Title: DIGITAL WATERMARKS IN TV AND RADIO BROADCASTS

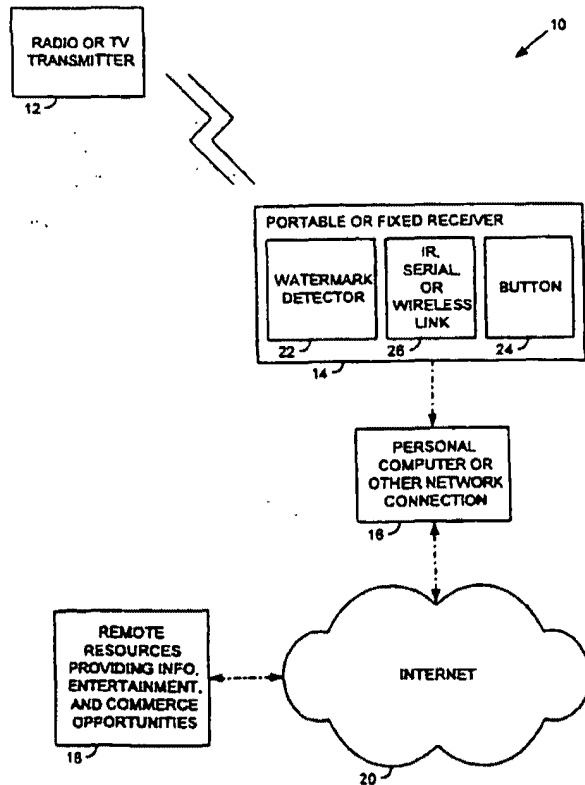

(57) Abstract: Wireless (26) and Internet (20) broadcasts can carry in-band digital information through the use of watermark technology (22). This digital information can be used to direct a user to a particular Internet site or resident application for supplemental or complimentary information, entertainment, merchandising, and commerce opportunities (18).



WO 01/01331 A1



patent (AT, BE, CH, CY, DE, DK, ES, FI, FR, GB, GR, IE, IT, LU, MC, NL, PT, SE), OAPI patent (BF, BJ, CF, CG, CI, CM, GA, GN, GW, ML, MR, NE, SN, TD, TG).

For two-letter codes and other abbreviations, refer to the "Guidance Notes on Codes and Abbreviations" appearing at the beginning of each regular issue of the PCT Gazette.

Published:

— *With international search report.*

DIGITAL WATERMARKS IN TV AND RADIO BROADCASTS

Related Application Data

This application claims priority to provisional applications 60/141,763, filed June 30, 1999; and 60/141,468, filed June 29, 1999.

The subject matter of the present application is related to that disclosed in US Patent 5,862,260, and in copending applications 08/746,613, filed November 12, 1996 (allowed, also published as WO 9743736); 09/343,104, filed June 29, 1999; 60/164,619, filed November 10, 1999; 09/503,881, filed February 14, 2000; 09/525,865, filed March 15, 2000; and 09/547,664, filed April 12, 2000.

Background and Summary of the Invention

Broadcast signals can carry in-band digital information through use of known watermark technology (a few examples of which are detailed in the cited patents and applications). This digital information can be used to direct a user to a particular internet site or resident application for supplemental or complimentary information, entertainment, merchandising, and commerce opportunities.

Brief Description of the Drawings

Fig. 1 shows an illustrative embodiment of the present invention.

Detailed Description

Referring to Fig. 1, an illustrative embodiment 10 of the present invention includes a radio or television transmitter 12, a portable or fixed radio or television receiver 14, a personal computer or other network connection 16, and remote resources 18 available through the internet 20.

The transmitter 12 is conventional, but includes a watermark encoder to embed a digital watermark in the transmitted signal. The receiver 14 is likewise generally conventional (e.g., including an RF amplifier, a mixer, one or more

intermediate frequency amplifiers, and a detector), but additionally includes a watermark detector 22, a button or other user interface feature 24 (which may be on a remote control associated with the receiver), and an external interface 26 (e.g., infrared, wireless, Bluetooth, serial, USB, firewire, etc.). In some embodiments, the receiver can be a species of computer.

The watermark encoding and decoding can follow the techniques set forth in the cited patents and applications. In such arrangements, the watermark payload data is combined with a pseudo-random carrier signal (e.g., by multiplying, XORing, etc.), and combined with (e.g. added to) the audio or video content signal. The carrier signal may be shaped in various ways. For example, zeroes in the carrier signal can be omitted (e.g., leaving values of -1 and 1, or -2, -1, 1, and 2, etc.), or the frequency spectrum of the carrier can be tailored to match the frequency spectrum of the signal being encoded, etc. In some embodiments, the watermarking also encodes a calibration signal with the payload data. This calibration signal is used in decoding, as detailed in the cited patents and applications (e.g., to permit accurate detection of the payload data even from a corrupted signal).

The computer 16 can be a personal computer, an internet appliance, or other network interface device. The computer includes provision for communicating with the external link of the receiver 14, and also includes a network connection for coupling to the internet 20. The remote resources 18 include the myriad servers coupled to the internet to provide information, entertainment, and commerce opportunities to users thereof.

In the illustrated system, audio material (such as a song or an advertisement) is transmitted to the receiver in the usual manner. Encoded in the audio signal is digital information represented as a watermark. Upon decoding at the receiver, this information is transmitted to the computer 16 (or stored for later transmission if the receiver does not have a persistent network connection).

The encoded information need only comprise a unique identifier, or database key. When passed to the computer 16 (and optionally therefrom to a remote resource 18), the identifier serves to initiate from such device one or more supplemental or complimentary applications corresponding to the encoded broadcast content, such as

purchasing a song for download, purchasing a CD containing the song, viewing news and concert schedules for recording artists, viewing a music video, etc.

Similar arrangements and benefits can be delivered through watermarked spoken word programming, and through television (video) broadcasts. The
5 broadcasts can be distributed through any of the conventional methods other than over-the-air, including cable and satellite.

The infrastructure through which the receiver 16 couples to the remote resources 18 can take various forms. In application 09/547,664, filed April 12, 2000, the assignee detailed one such arrangement. In that system, the user device (e.g.,
10 receiver 14 or computer 16) dispatches the watermark ID to a router computer. That computer includes a database that stores a URL corresponding to each watermark ID. Upon receiving a watermark ID, the router computer returns the corresponding URL to the originating device (12 or 16). A browser at the originating device then establishes a link to the specified URL. That URL then provides the information,
15 entertainment, or commerce opportunity corresponding to the encoded broadcast.

The just-detailed system is advantageous in that it permits the encoding of a short identifier in the broadcast (e.g., instead of a lengthy URL). Moreover, the corresponding URL can be changed over time, as needed. Other embodiments of the present invention, however, do not need this level of complexity; the encoded
20 identifier can more directly trigger the desired remote resource response.

Turning to particular cases, consider a product advertisement encoded with watermark data that links to product specifications, multi-media product demonstrations, and/or purchase instructions. Alternatively, for commonplace items, the user might merely push a "buy" button 24 on the receiver and the order could be
25 placed automatically (e.g., using one-click technology of the type detailed in Amazon's patent 5,960,411), or an order form could be invoked on the screen of the computer 16 as soon as the data was transmitted to it.

If a particular song was playing, the digital watermark transmitted with the song could cause a picture of the singer to appear on the personal computer.
30 Alternatively, through an automatic link to the internet, users could indicate their like or dislike for the song. In still other applications the link can be used to allow the user

to indicate a "vote" concerning a subject being played over the audio link. (In such embodiments, the embedded ID identifies the subject matter being voted on, and likewise serves to specify the remote resource 18 that is to receive the vote. To that resource the user's computer can dispatch a "yes" or "no" vote, a "like" or "dislike" preference, etc., by corresponding data sent over the internet.

As will be recognized, embodiments like that detailed can be used to enable interactive advertisement and promotion for local radio and TV broadcasters, generating traffic and fulfillment activities for local merchants. In one such embodiment, network broadcast content is locally customized with links corresponding to local merchants and other resources. Thus, a Ford advertisement may be customized to initiate a link to a local Ford dealership.

(Such local customization can be performed by the broadcaster or by another party. In some embodiments, nationally-distributed broadcast content can include links suitable for a national audience (e.g., to corporate web sites of advertisers). The local broadcaster may process such network feeds to identify such national links. When same are encountered, the local broadcast processor may look-up a corresponding local link. The existing national link data can then be replaced with the local link data. Or, the broadcast may have been encoded with "blank" watermark payload bits that can be filled-in by the local broadcaster without removing the national link. These supplemental payload bits can serve to indicate the locality in which the payload was received, permitting a router computer or the like to return a URL appropriate to that area.)

By employing such watermark-based content augmentation, satellite content distribution can enjoy a virtual high speed asynchronous network capability by downstreaming relatively small digital watermark payloads as segues to PCs and other devices with higher bandwidth connections. Rather than sending large payloads via the satellite link, the distributor sends "pointers" that direct receivers and recipients to certain applications on the other networks; essentially, off-loading the heavy lifting to other carriers so as to provide more value to its customers and content providers with very little bandwidth consumption. Auxiliary content that is not desired by all satellite subscribers is not sent over the satellite; those subscribers

employ the satellite-conveyed watermark data to obtain such auxiliary content using other connections (e.g., terrestrial internet).

Radio over the internet is increasingly popular. However, the screen of the internet terminal is poorly utilized in such radio broadcasts. In accordance with
5 another aspect of the invention, a watermark decoded from a web broadcast is decoded, and is used to enhance the experience by supplementing the audio with accompanying visual presentations.

In one such embodiment, the display presents streaming and other media on the screen while the internet radio is playing, such ancillary content being related to
10 the then-broadcast radio content. This ancillary visual information can include concert schedules, fan news about the musician or person being broadcast, commercial web sites offering CDs, etc. During radio advertisements the display can present associated commercial information, with accompanying visual and/or video promotional materials. In addition to eye-catching visual presentations, these displays
15 can include the opportunity to buy the advertised product, or download a "trial" version. (The visual displays can include conventional user interface features, such as buttons that can be selected by a user to initiate a purchase transaction or other operation in known manners.)

Technically, the computer radio decodes embedded watermark data from the
20 audio programming. In some embodiments, the watermark literally conveys the address of one or more web sites that are to be displayed. The computer can be programmed to recognize these embedded web addresses, and display the corresponding web content in one or more separate browser windows. These windows can be tiled or otherwise presented on the display screen, together with the
25 radio user interface. (The ancillary windows may overlie the radio interface in some embodiments.) As the radio content changes, the embedded watermark information also changes. Web displays corresponding to the earlier-decoded watermark are discontinued, and new web displays corresponding to the current watermark information are presented.

30 As noted, the audio broadcast need not be literally encoded with web addresses. Instead, the audio can be encoded with data including an identifier (e.g., 32

bits). On detecting this identifier, the computer connects to a remote web server (whose address is pre-identified) and provides this identifier. The remote server responds with the web addresses of the content to be displayed. The local computer then loads and displays these web pages, as in the first embodiment. As the audio programming changes, the embedded identifier also changes, leading to changed web addresses corresponding to the current audio material.

Returning to the original example of a watermark-aware radio, consider a car radio that has a "capture" button on the front panel (or other form of user interface, e.g., a Capture icon on a GUI). If a user hears a song they want to record and keep, they press the Capture button while the song is playing. In response, the radio device decodes a watermark embedded in the music, and thereby knows the identity of the music. The radio then makes a wireless transmission identifying the user and the desired song. A local repeater network picks up the wireless signal and relays it (e.g. by wireless rebroadcast, by modem, or other communication medium) to a music clearinghouse. The clearinghouse charges the user a nominal fee (e.g. via a pre-arranged credit card), and queues the music for download to a predetermined location associated with the user.

In one embodiment, the predetermined location is the user's own computer. If a "live" IP address is known for the user's computer, the music can be transferred immediately. If the user's computer is only occasionally connected to the internet, the music can be stored at a web site (e.g. protected with a user-set password), and can be downloaded to the user's computer whenever it is convenient.

In other embodiments, the predetermined location is a personal music library maintained by the user. The library can take the form, e.g., of a hard-disk or semiconductor memory array in which the user customarily stores music. This storage device is adapted to provide music data to one or more playback units employed by the user (e.g. a personal MP3 player, a home stereo system, a car stereo system, etc.). In most installations, the library is physically located at the user's residence, but could be remotely sited, e.g. consolidated with the music libraries of many other users at a central location.

The personal music library can have its own internet connection. Or it can be equipped with wireless capabilities, permitting it to receive digital music from wireless broadcasts (e.g. from the clearinghouse). In either case, the library can provide music to the user's playback devices by short-range wireless broadcast.

5 By such arrangement, a user can conveniently compile an archive of favorite music – even while away from home.

Many variants of the foregoing are of course possible. The radio can be a portable unit (e.g. a boombox, a Walkman radio, etc.) or a home device, rather than an automotive unit. The UI feature employed by the user to initiate capture a musical
10 selection need not be a button (physical or on-screen). For example, in some embodiments it can be a voice-recognition system that responds to spoken commands, such as “capture” or “record.” Or it can be a form of gesture interface.

Instead of decoding the watermark only in response to the user's “capture” command, the radio can decode watermarks from all received programs, and keep the
15 most recent in a small FIFO memory. By such arrangement, the user need not issue the capture instruction while the song is playing, but can do so even after the song is finished.

In some embodiments, data corresponding to the watermark can be made available to the user in various forms. For example, it can be presented to the user on
20 an LCD screen, identifying the artist and song currently playing. If a corresponding UI button is activated, the device can so-identify the last several selections. Moreover, the data need not be presented to the user in displayed form; it can be announced by known computer-speech technologies instead.

In embodiments in which the watermark does not convey ASCII text data, but
25 instead conveys UIDs (unique identifiers), or coded abbreviations, the device must generally interpret this data before presenting it to the user. In an illustrative embodiment, the device is a pocket-sized FM radio and is equipped with a 1 megabyte semiconductor non-volatile RAM memory. The memory includes a data structure that serves as a look-up table, matching code numbers to artist names and
30 song titles. When the user queries the device to learn the identify of a song, the memory is indexed in accordance with one or more fields from the decoded

watermark, and the resulting textual data from the memory (e.g. song title and artist) is announced or displayed to the user.

In most applications, such memory will require frequent updating. The RF receiver provides a ready mechanism for providing such updated data. In one
5 embodiment, the radio "awakens" briefly at otherwise idle moments and tunes to a predetermined frequency at which updated data for the memory is broadcast, either in a baseband broadcast channel, or in an ancillary (e.g. SCA) channel. Or such data can be repeatedly transmitted on an SCA channel, received whenever the radio is turned
on.

10 In variants of the foregoing, internet delivery of updated memory data can be substituted for wireless delivery. For example, the artist/song title memory in the personal player can be updated by placing the player in a "nest" every evening. The nest (which may be integrated with a battery charger for the appliance) can have an internet connection, and can exchange data with the personal device by infrared,
15 inductive, or other proximity-coupling technologies, or through metal contacts. Each evening, the nest can receive an updated collection of artists/song titles, and can re-write the memory in the personal device accordingly. By such arrangement, the watermark data can always be properly interpreted for presentation to the user.

The "Capture" concepts noted above can be extended to other functions as
20 well. One is akin to forwarding of email. If a consumer hears a song that another friend would enjoy, the listener can send a copy of the song to the friend. This instruction can be issued by pressing a "Send" button, or by invoking a similar function on a graphical (or voice- or gesture-responsive) user interface. In response, the appliance so-instructed can query the person as to the recipient. The person can
25 designate the desired recipient(s) by typing in a name, or a portion thereof sufficient to uniquely identify the recipient. Or more typically, the person can speak the recipient's name. As is conventional with hands-free vehicle cell phones, a voice recognition unit can listen to the spoken instructions and identify the desired recipient. An "address book"-like feature has the requisite information for the recipient (e.g., the
30 web site, IP address, or other data identifying the location to which music for that recipient should stored or queued, the format in which the music should be delivered,

etc.) stored therein. In response to such command, the appliance dispatches instructions to the clearinghouse, including an authorization to debit the sender's credit card for the music charge. Again, the clearinghouse attends to delivery of the music in a desired manner to the specified recipient.

5 Still further, a listener may query the appliance (by voice, GUI or physical button, textual, gesture, or other input) to identify CDs on which the then-playing selection is recorded. Or the listener may query the appliance for the then-playing artist's concert schedule. Again, the appliance can contact a remote database, relay the query, and forward data from the watermark payload identifying the artist and/or
10 song title to which the query relates. The database locates the requested data, and relays same back to the appliance for presentation (via a display, by machine speech, or other output) to the user. If desired, the user can continue the dialog with a further instruction, e.g., to buy one of the CDs on which the then-playing song is included. Again, this instruction may be entered by voice, GUI, etc., and dispatched from the
15 appliance to the clearinghouse, which can then complete the transaction in accordance with pre-stored information (e.g. credit card account number, mailing address, etc.). A confirming message is relayed to the appliance for presentation to the user.

 While the foregoing transactions require a link to a remote site or database, other watermark-based consumer services can be provided without such a link. For
20 example, a user can query the appliance as to the artist or song-title of the selection currently playing. The appliance can consult the embedded watermark data (and optionally consult a memory to determine the textual names associated with coded watermark data), and provide the requested information to the user (e.g., by a display, annunciation, or other output).

25 The foregoing concepts (e.g. Capture, Send, etc.) can also be employed in connection with internet- rather than radio-delivery of music.

 In other embodiments of the invention, the broadcast is not encoded with different data at different times (e.g., a different payload for each song). Instead, the broadcast is constantly encoded with a single identifier, e.g., identifying the
30 broadcaster. The encoding can be the broadcaster's FCC call sign, a binary identifier corresponding to a particular station, etc. Such encoding can be effected anywhere in

the audio chain, e.g., in the audio feed between the studio and the broadcast transmitter. The audio signal can be converted to digital form (if not already in such form), summed with a low level watermark signal, and converted back to analog form (if necessary).

5 In such arrangements, the user device (e.g., receiver 14) can include a real time clock. When a user hears or sees a broadcast of interest, and operates the "Capture" button (or other user interface feature), time data from the clock is written into a memory. The time data, and the decoded station identifier, can then (or later) be forwarded to a remote database to which the broadcaster writes its play log. By
10 indexing the broadcaster's play log with the captured time data, the audio (or video) selection being broadcast at that instant can be identified. The content identifier thereby obtained can then be utilized as above-described to augment the user's enjoyment of the broadcast.

15 From the foregoing, it will be recognized that certain embodiments of the present invention allow internet and broadcast audio/video to be used to invoke the presentation of ancillary promotions, merchandizing, supplemental information, and entertainment – all keyed off watermark data.

20 To provide a comprehensive disclosure without unduly lengthening this specification, the above-detailed patents and applications are incorporated herein by reference.

 Having described and illustrated the principles of the invention with reference to illustrative embodiments, it should be recognized that the invention is not so limited.

25 For example, while the detailed embodiment included a watermark decoder as part of the broadcast receiver, this is not essential. In other embodiments the receiver may include, for example, a memory (e.g., RAM) in which sampled excerpts of received audio can be stored under control of an associated CPU. The stored audio can thereafter be transferred to the computer 16, and the watermark decoded therefrom at the computer.

30 To save storage space in the receiver memory, the audio can be processed to reduce its size, without unduly impairing the watermark information conveyed

thereby. One way this can be accomplished is to high pass filter the audio (e.g., with a cutoff frequency of one-fourth the sample frequency). Then the filtered audio can be quantized into a three state signal: -1, 0, or 1, depending on the polarity of the filtered signal. (Values within a predetermined threshold of 0 can be assigned a value of 0.) It will be recognized that such processing is a form of lossless compression – lossy because the process is not reversible. The watermark payload can be decoded from the resulting three-state signal (e.g., using the techniques disclosed in the cited patents and applications), even though the underlying audio carrier signal is essentially lost. This bit sequence can be further compressed using known lossless compression techniques (e.g., LZ77 or LZ78) to further save on storage requirements.

The just-described processing technique is illustrative only. The high pass filtering can be used without the quantization, and vice versa. Still other compression techniques can naturally be used, provided same do not unduly impair the encoded watermark information.

In one particular embodiment in which the receiver logs snippets of audio, all audio received by the receiver is digitized, and the last 5 seconds are always available in a FIFO RAM buffer. Upon activating the button 24 or other control, those 5 seconds of audio are copied into a separate retention memory, and the five next-following seconds of audio are likewise written into that retention memory, yielding 10 seconds of data from which the watermark can later be discerned. (The audio processing operation just described can be performed on-the-fly during such operation, or by post processing.) A number of such excerpts can be stored – one each time the button 24 is activated - depending on the capacity of the retention memory. Known user interface techniques can be employed to allow the user to manage this collection of data excerpts, e.g., controlling which are transmitted to the computer 16, which are invoked to obtain related internet content, which are permanently stored on-disk in the computer 16 to serve as long-term bookmarks to internet sites of particular interest, etc.

While receiver 14 and computer 16 are described as separate units, this need not be the case. The detailed functionality of these devices can be provided in a single unit.

Similarly, while the detailed embodiments employ particular watermarking techniques detailed in the cited patents and applications, the principles are equally applicable with any other digital watermarking technology, including those that transform the audio or video signal to another domain (e.g., wavelet, DCT, etc.), and alter the signal representation by changing the signal coefficients in such domain.

More generally, while the detailed embodiments have employed watermark technology, other arrangements can employ different auxiliary data-conveyal technologies, including SCA subcarriers, vertical blanking interval techniques, etc.

While the detailed embodiments focused on audio broadcast applications, the same principles can be employed with television, e.g., by encoding the picture information or the accompanying sound information. And, as noted, the techniques are likewise applicable to the internet-delivery of content, not involving over-the-air broadcast.

While the detailed embodiments contemplated that the broadcast content would correspond to a single internet destination, in other embodiments this may not be the case. In some embodiments, a song or other content may correspond to links to several alternative destinations. The user can be presented a menu of such links from which to choose. Or a link to one of several alternative destinations may be automatically chosen based on the context or environment in which the content was encountered. (E.g., if a user activates the "Capture" button on a portable radio receiver, a different link may be pursued than if the user activates the button while using a desktop computer. In such cases, context information sufficient to distinguish such settings would be relayed from the device to the remote system.)

In some of the above-described embodiments, the augmentation of the broadcast content is initiated by a user action, e.g., activating a Capture button. In others, the augmentation is automatic (e.g., presentation of streaming media corresponding to a watermark decoded from received audio). Still other arrangements are possible. For example, the augmented information can be automatically retrieved, but not presented to the user unless called for. The augmentation data can be cached, e.g., on the user's device, and presented immediately, on demand. In one such arrangement, a user listening to an internet radio broadcast can summon additional

information by using dropdown menus of the sort typically associated with Windows applications. A "More" menu could present options such as "About the artist," "Order this music," "Concert schedules," etc. Unless requested, such information stays hidden. But when such menu is activated, the corresponding information is
5 delivered from the cache.

The particular combinations of elements and features in the above-detailed embodiments are exemplary only; the interchanging and substitution of these teachings with other teachings in this and the incorporated-by-reference patents/applications are also contemplated.

10 In view of the wide variety of embodiments to which the principles and features discussed above can be applied, it should be apparent that the detailed embodiments are illustrative only and should not be taken as limiting the scope of the invention. Rather, we claim as our invention all such modifications as may come
within the scope and spirit of the following claims and equivalents thereof.

15

WE CLAIM:

1. In a radio or television broadcasting system that conveys a content signal to an audience, an improvement comprising steganographically encoding the content signal with an in-band digital watermark prior to its broadcast, the digital watermark conveying a plural-bit identifier, the identifier serving to identify an internet-available resource to which a recipient of said content signal can refer to obtain additional information or commerce opportunities related to the broadcast.
5
2. The method of claim 1 in which the identifier does not convey a literal URL, but instead conveys a code that is mapped to a corresponding URL through a database.
10
3. The method of claim 1 in which said encoding includes processing with a shaped pseudo-random signal.
15
4. A broadcasting system that broadcasts beyond a single local area, according to claim 1, in which each of several local broadcast outlets to which the content is distributed encode the content with a different digital watermark, so that the internet-available resources identified thereby are customized to the outlets' respective localities.
20
5. The broadcasting system of claim 3 in which the local outlet encoding of said content with said watermark is performed in response to detection of a different watermark in an input content signal.
25
6. A broadcast receiver, the receiver having an RF amplifier, a mixer, an intermediate frequency amplifier, a detector, a speaker, and a watermark decoder, the watermark decoder serving to decode a plural-bit digital watermark steganographically encoded within a received broadcast signal, said plural-bit digital watermark serving to identify an internet-available resource to which a user of said
30

receiver can refer to obtain additional information or commerce opportunities related to the broadcast.

5 7. The receiver of claim 6 in which the watermark decoder employs a shaped pseudo-random signal to decode said watermark.

8. The receiver of claim 6 in which the watermark decoder refers to a calibration signal embedded as part of the digital watermark in decoding said watermark.

10

9. The receiver of claim 6 in which the watermark decoder has an input coupled to an output of the detector.

10. The receiver of claim 6 in which the watermark decoder has said input
15 coupled to the speaker.

11. A television receiver according to claim 6.

20

12. A radio receiver according to claim 6.

13. The receiver of claim 6 further including a control by which a user can cause the receiver to act upon a watermark in said received broadcast signal.

14. The receiver of claim 6 further comprising a memory, the receiver serving
25 to store decoded watermark data in said memory.

15. The receiver of claim 14 further including a control by which a user can cause the receiver to store the decoded watermark data in said memory.

30 16. The receiver of claim 6, further including an interface permitting coupling of data from said receiver to a remote device.

17. The receiver of claim 16 in which the interface includes a wireless transmitter.

5 18. The receiver of claim 17 in which the wireless transmitter comprises an infrared transmitter.

19. The receiver of claim 16 in which the interface couples to a computer device.

10

20. The receiver of claim 6, further comprising a memory, the memory having data stored therein permitting decoded watermark data to be interpreted into human-understandable form.

15 21. The receiver of claim 20, further including a display on which data from said memory can be presented to a user.

22. The receiver of claim 20, further including an annunciator for announcing data from said memory to a user.

20

23. A method of operating a receiver comprising:

listening to or viewing an output from said receiver until content of interest is presented;

25 activating a control associated with said receiver, said activation initiating the following events:

transmitting data corresponding to an in-band watermark detected in said content, from said receiver to an internet connected resource; and

receiving information or a commerce opportunity relating to said content of interest from the internet

30

24. The method of claim 23 in which the events initiated by activation of said control including decoding a watermark from said content of interest.

5 25. The method of claim 24 in which said decoding includes processing with a shaped pseudo-random signal.

26. The method of claim 24 in which the decoding includes detecting a calibration signal encoded as part of said watermark.

10 27. The method of claim 23 in which the events initiated by activation of said control include reading earlier-decoded watermark data from a memory in said receiver for transmission to the internet connected resource.

15 28. The method of claim 23 that includes:
receiving the transmitted data at a first internet-connected resource;
identifying at said first resource a URL identifying a second internet-connected resource that corresponds to said transmitted data; and
providing data from said URL to a user of the receiver.

20 29. The method of claim 28 that includes relaying said URL from the first internet-connected resource to a computer associated with the user, and directing a browser on said computer to said URL.

25 30. A broadcast receiver, the receiver having an RF amplifier, a mixer, an intermediate frequency amplifier, a detector, a speaker, a sampler, a processor, and a memory, the processor serving to selectively store data corresponding to a received broadcast to the memory, said data encoding a plural-bit digital watermark that identifies an internet-available resource to which a user of said receiver can refer to obtain additional information or commerce opportunities related to the broadcast.

30

31. The receiver of claim 30 in which the processor stores said sampled data in response to user activation of a control.

5 32. The receiver of claim 30 in which the data stored in the memory is not simply sampled broadcast data, but has been processed by the processor to reduce storage space while still permitting the watermark to be decoded therefrom.

33. A signal processor assembly comprising:
an input for receiving a sampled content signal having a plural-bit digital
10 watermark steganographically encoded therein; and
a processor for processing the sampled content signal to remove low frequency components thereof, the processed signal nonetheless including said watermark therein.

15 34. The signal processor of claim 33 in which the processor performs a high pass filtering operation on the sampled content signal.

35. The signal processor of claim 33 in which the processor performs a three-
state quantization operation on the sampled content signal.

20

36. A broadcast receiver according to claim 33, additionally including an RF amplifier, a mixer, an intermediate frequency amplifier, a detector, a speaker, and a sampler.

25

37. A method of signal processing, comprising:
receiving a sampled content signal having a plural-bit digital watermark
steganographically encoded therein;

high pass filtering the sampled content signal to remove low frequency
components thereof; and

30

storing the filtered signal in a memory; and
thereafter, providing the stored, filtered signal to a watermark decoder.

38. A computer device including a memory, an internet interface, and a watermark decoder, characterized in that the memory has a processed content signal stored therein that encodes a plural-bit digital watermark, the content signal
5 corresponding to audio, video, or still image content, but being sufficiently processed that the signal is substantially unusable to render audio, video, or still image content to a user of the device; the watermark identifying an internet-available resource to which a user of said device can refer through said interface to obtain additional information or commerce opportunities related to the content.

10

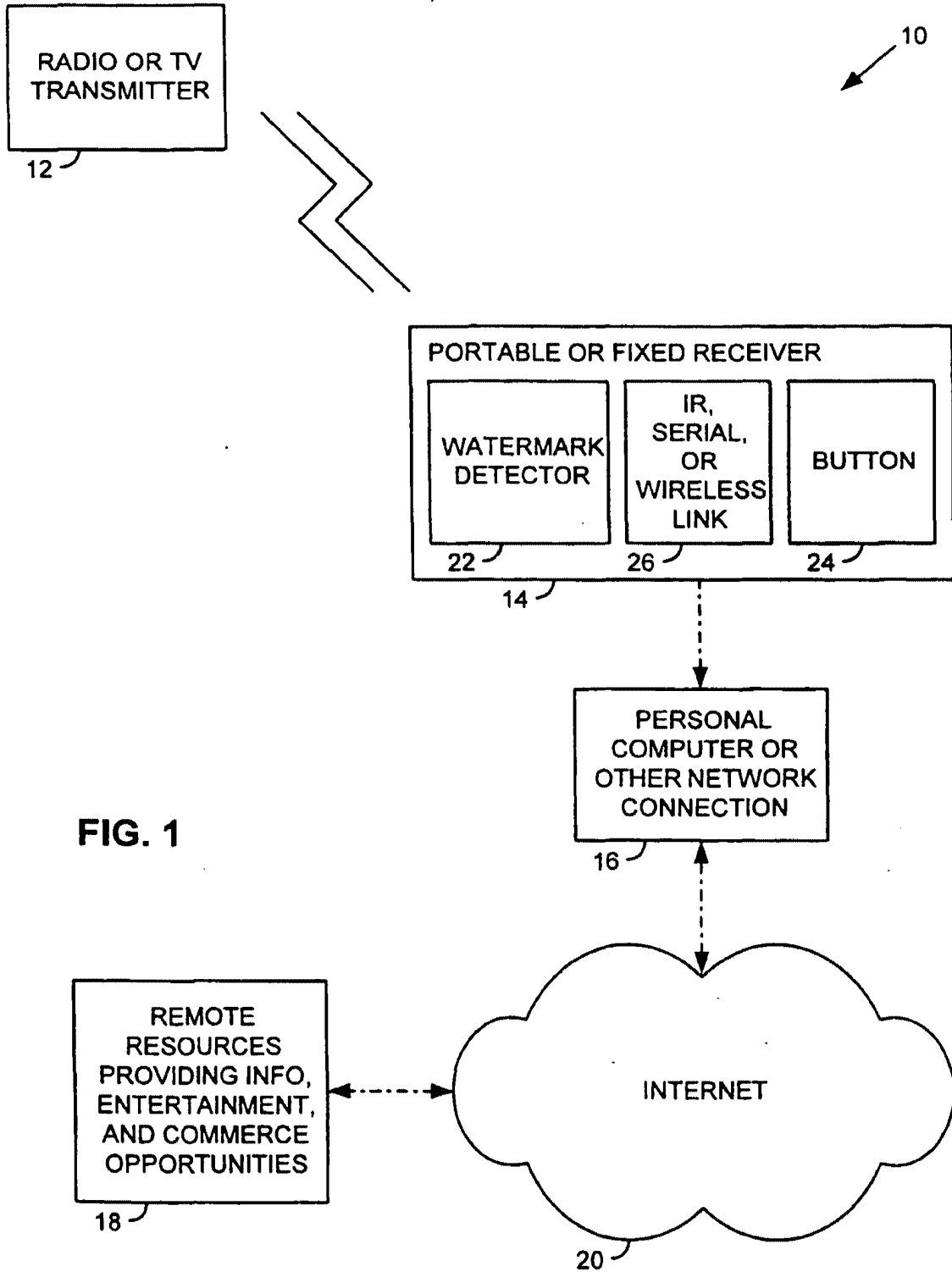

FIG. 1

INTERNATIONAL SEARCH REPORT

International application No.
PCT/US00/17157

| A. CLASSIFICATION OF SUBJECT MATTER IPC(7) : G06K 9/00 US CL : 382/100, 232; 380/54 According to International Patent Classification (IPC) or to both national classification and IPC | | |
|---|---|--|
| B. FIELDS SEARCHED Minimum documentation searched (classification system followed by classification symbols) U.S. : 382/100, 232; 380/54 Documentation searched other than minimum documentation to the extent that such documents are included in the fields searched NONE Electronic data base consulted during the international search (name of data base and, where practicable, search terms used) EAST 1.1, IEEE Search terms: watermark, broadcast, video, audio, internet, amplifier, receiver | | |
| C. DOCUMENTS CONSIDERED TO BE RELEVANT | | |
| Category* | Citation of document, with indication, where appropriate, of the relevant passages | Relevant to claim No. |
| Y | US 5,892,900 A (GINTER et al.) 06 April 1999, fig. 1, elements 200, 204, 205, 208; col. 5, lines 15-45; col. 37, lines 15-50. | 1-38 |
| Y | US 5,778,102 A (SANDFORD, II et al.) 07 July 1998, fig. 11, elements 11, 12; col. 13, lines 29-45; col. 15, lines 9-34. | 1-38 |
| Y | US 5,900,608 A (IIDA) 04 May 1999, fig. 1, elements 10, 20; fig. 14, element 300, 400; col. 25, lines 10-40. | 1-38 |
| Y | US 5,915,027 A (COX et al.) 22 June 1999, col. 4, lines 15-40. | 1-38 |
| A | US 5,673,316 A (AUERBACH et al.) 30 September 1997, col. 6, lines 15-47. | 1-38 |
| <input checked="" type="checkbox"/> Further documents are listed in the continuation of Box C. <input type="checkbox"/> See patent family annex. | | |
| * Special categories of cited documents: *A* document defining the general state of the art which is not considered to be of particular relevance *E* earlier document published on or after the international filing date *L* document which may throw doubts on priority claim(s) or which is cited to establish the publication date of another citation or other special reason (as specified) *O* document referring to an oral disclosure, use, exhibition or other means *P* document published prior to the international filing date but later than the priority date claimed | | *T* later document published after the international filing date or priority date and not in conflict with the application but cited to understand the principle or theory underlying the invention *X* document of particular relevance; the claimed invention cannot be considered novel or cannot be considered to involve an inventive step when the document is taken alone *Y* document of particular relevance; the claimed invention cannot be considered to involve an inventive step when the document is combined with one or more other such documents, such combination being obvious to a person skilled in the art *Z* document member of the same patent family |
| Date of the actual completion of the international search 21 SEPTEMBER 2000 | | Date of mailing of the international search report 18 OCT 2000 |
| Name and mailing address of the ISA/US Commissioner of Patents and Trademarks Box PCT Washington, D.C. 20231 Facsimile No. (703) 305-3230 | | Authorized officer JAY PATEL <i>James R. Matthew</i> Telephone No. (703) 308-7728 |

INTERNATIONAL SEARCH REPORT

International application No.
PCT/US00/17157

| C (Continuation). DOCUMENTS CONSIDERED TO BE RELEVANT | | |
|---|--|-----------------------|
| Category* | Citation of document, with indication, where appropriate, of the relevant passages | Relevant to claim No. |
| A | US 5,742,845 A (WAGNER) 21 April 1998, fig. 1, element 14; col. 7, lines 25-55. | 1-38 |

Form PCT/ISA/210 (continuation of second sheet) (July 1998)*

19 BUNDESREPUBLIK
DEUTSCHLAND



DEUTSCHES
PATENTAMT

12 Offenlegungsschrift
10 DE 44 27 046 A 1

51 Int. Cl.⁶:
H 04 N 5/445
H 04 N 7/08
H 04 M 1/26

21 Aktenzeichen: P 44 27 046.1
22 Anmeldetag: 29. 7. 94
43 Offenlegungstag: 1. 2. 96

DE 44 27 046 A 1

71 Anmelder:
Fridley Technologies Ltd., British Virgin Islands, VG
74 Vertreter:
Konle, T., Dipl.-Ing., Pat.-Anw., 81247 München

72 Erfinder:
Goldscheider, Daniel, Wien, AT; Eitz, Gerhard, 85586 Poing, DE; Eichhorn, Roland, 80634 München, DE

64 Verfahren zum Wiedergeben von in einem Fernseh- oder Hörfunk-Programmsignal enthaltenen Zusatzinformationen

57 Um das Bestellen von Produkten, die im Fernsehen oder Hörfunk präsentiert werden, für den Fernseh- bzw. Hörfunkteilnehmer so einfach wie möglich zu machen und gleichzeitig die für eine Bestellung erforderliche Rechtssicherheit zu gewährleisten, wird vorgeschlagen, Zusatzinformationen, insbesondere in Form von Schrift und ggf. von Grafikelementen, innerhalb des Programmsignals in zeitlicher Korrelation zu dessen Programminhalt zu übertragen und empfangenseitig zu decodieren. Die empfangenen Zusatzinformationen werden empfangenseitig für eine bestimmte Dauer zwischengespeichert. Auf einen ersten Befehl des Benutzers wird eine in der zuletzt empfangenen Zusatzinformation enthaltene Klerschrift und ggf. Grafikinformaton für eine bestimmte Zeitdauer wiedergegeben. Während der Wiedergabe der Klerschrift und ggf. der Grafikinformaton wird auf einen zweiten Befehl des Benutzers aus der zuletzt zwischengespeicherten Zusatzinformation eine der Klerschrift und ggf. Grafikinformaton zugeordnete Bestell- oder Auswahlinformation entnommen und an eine Wählvermittlungseinrichtung (z. B. Modem) weitergeleitet.

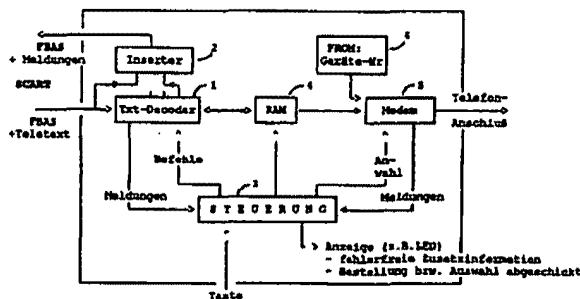

DE 44 27 046 A 1

Beschreibung

Die Erfindung bezieht sich auf ein Verfahren gemäß dem Oberbegriff des Patentanspruchs 1. Ein derartiges Verfahren ist aus Rundfunktechnischen Mitteilungen, Heft 1, 1978 "Anlage zur Aufbereitung und Einblendung von Untertiteln nach dem englischen Teletext-Standard" bekannt.

Aus der vorgenannten Literaturstelle ist es bekannt, bei fremdsprachigem Fernsehton oder für Gehörlose in das Fernsehbild Untertitel einzublenden. Die eingeblendeten Untertitel sind dabei zeitlich mit dem Fernsehbild korreliert.

Es ist ferner bekannt, in Fernseh-Werbesendungen Produkte vorzustellen, und am Ende der Werbesendung getrennt für jedes Land die Preise und die Telefonnummern anzugeben, unter welchen die zuvor erworbenen Produkte bestellt werden können. Dieses sogenannte "Teleshopping" hat jedoch den Nachteil, daß vom Fernsehteilnehmer die betreffenden Telefonnummern mitgeschrieben werden müssen; außerdem leidet der unmittelbare Bezug zwischen der fernsehmäßigen Präsentation des Produktes und der Anzeige von Preis und Telefonnummer. Hinzu kommt, daß der Fernsehteilnehmer, nachdem er die Telefonnummer abgeschrieben hat, einen telefonischen Bestellvorgang durchführen muß, was dann, wenn viele Fernsehteilnehmer gleichzeitig bestellen wollen, eine Vielzahl von Wählversuchen erforderlich macht.

Die Aufgabe der Erfindung besteht darin, ein Verfahren der eingangs erwähnten Art für den Bestellvorgang von Produkten nutzbar zu machen, um das Bestellen für den Teilnehmer so einfach wie möglich zu machen und gleichzeitig die für eine Bestellung erforderliche Rechtssicherheit zu gewährleisten.

Diese Aufgabe wird erfindungsgemäß durch die kennzeichnenden Merkmale des Patentanspruchs 1 gelöst.

Vorteilhafte Ausgestaltungen und Weiterbildungen des erfindungsgemäßen Verfahrens nach Anspruch 1 ergeben sich aus den Unteransprüchen.

Die Erfindung beruht auf der Überlegung, dem Fernseh- oder Hörfunkteilnehmer per Knopfdruck die Möglichkeit zu geben, bei der bildlichen oder akustischen Präsentation von Produkten oder Dienstleistungen eine Klarschriftinformation abzurufen, welche ihm durch Einblendung in das Fernsehbild bzw. Wiedergabe auf einem Display am Empfänger sichtbar gemacht wird. Insbesondere handelt es sich bei der Klarschriftinformation um nähere Angaben über das Produkt einschließlich Preis, welche für eine Kaufentscheidung des Teilnehmers erforderlich sind. Zur Bestellung braucht der Teilnehmer nur noch ein weiteres Mal auf eine spezielle Taste seines Empfängers bzw. dessen Fernbedienung zu drücken, worauf der Bestellvorgang automatisch ausgelöst wird. Ferner erhält der Teilnehmer nach Auslösung eines Bestellvorganges eine Quittiermeldung.

Die Erfindung wird anhand eines in den Zeichnungen dargestellten Ausführungsbeispiels näher erläutert. Es zeigen

Fig. 1a und Fig. 1b zwei Teletextseiten mit dann enthaltenen Zusatzinformationen;

Fig. 2 eine empfängerseitige Einrichtung nach der Erfindung zur Dekodierung der Zusatzinformation,

Fig. 3 eine Darstellung der zeitlichen Aufeinanderfolge zwischen einzelnen Fernsehbeiträgen und den zugehörigen Zusatzinformationen, und

Fig. 4 eine Darstellung der zeitlichen Aufeinanderfol-

ge zwischen der Anzeige der Klarschriftinformation und der den Zeitfenstern zur Auslösung eines Bestellvorgangs bzw. der Übermittlung einer Auswahlinformation.

Die für eine Bestellung bzw. eine Auswahl notwendigen Daten werden als Zusatzinformation zeitlich korreliert zum Fernsehprogramm auf Teletextseiten ähnlich wie Untertitel mit bestimmten Seitennummern gesendet, die der Empfangseinrichtung bekannt sind. Das in Fig. 1a dargestellte Beispiel ("Rotes Sommerkleid für DM 19,95") enthält eine Klarschrift-Information, eine Telefon-Nummer und eine Produkt-Nummer zur Bestellung des Sommerkleids. Alternativ kann, wie Fig. 1b zeigt, anstelle der Produkt-Nummer eine Nummer für eine Auswahlidentifikation, beispielsweise für eine anonyme Umfrage ("Gewinnt XYZ die nächste Wahl?") übertragen werden.

In Fig. 2 ist ein Blockschaltbild einer Empfangseinrichtung nach der Erfindung dargestellt, die extern aufgestellt und mit einem Fernsehgerät über ein Scart-Kabel verbunden ist. Über das Scart-Kabel wird das empfangene Fernsehsignal mit den Teletextdaten aus dem Fernsehgerät auf einen in der Empfangseinrichtung eingebauten Teletext-Dekoder und einen Inserter geführt. Der Teletext-Dekoder 1 detektiert aus den einlaufenden Teletext-Daten diejenigen Seiten, die von einer Steuerung angefordert werden und untersucht den Seiteninhalt der selektierten Seiten (sh. Fig. 1a oder Fig. 1b) nach einer Zusatzinformation.

Eine in ein Fernsehgerät eingebaute Empfangseinrichtung nach der Erfindung ist ähnlich wie eine Empfangseinrichtung mit Scart-Kabel aufgebaut. Bei der eingebauten Empfangseinrichtung entfällt der Inserter und die RGB-Signale am Ausgang des Teletext-Dekoders werden direkt über einen Schalter und entsprechende Verstärker auf den Fernsehbildschirm gegeben.

Wird eine fehlerfreie Zusatzinformation von dem Teletext-Decoder 1 festgestellt, so erfolgt eine Zwischenspeicherung in einem RAM-Speicher, eine Meldung an die Steuerung 3 und eine entsprechende Anzeige für den Benutzer, beispielsweise durch Blinken einer grünen LED-Anzeige. Bei bereits in Fernsehempfängern integrierten Empfangseinrichtungen nach der Erfindung ist es auch denkbar, eine entsprechende Signalisierung an der Gehäusefrontseite des Fernsehgerätes vorzunehmen.

Außerdem kann dem Benutzer das Vorhandensein von einer Zusatzinformation dadurch signalisiert werden, daß beispielsweise ein Logogramm vom Teletext-Dekoder generiert, vom Inserter in das Fernsehsignal eingestanz, über das Scart-Kabel zum Fernsehgerät zurückgeführt und auf dem Bildschirm zusammen mit dem gewählten Programm in einer Ecke auf dem Bildschirm angezeigt wird.

Sind nun Zusatzinformationen vorhanden und betätigt der Benutzer eine Taste, die der Empfangseinrichtung zugeordnet ist und die entweder am Gehäuse der Empfangseinrichtung oder an der Fernbedienung des Fernsehgerätes oder der erfindungsgemäßen Empfangseinrichtung angeordnet sein kann, so wird ein entsprechendes Steuersignal an die Steuerung übermittelt, die daraufhin den Teletext-Dekoder 1 veranlaßt, die zuletzt zwischengespeicherte Zusatzinformation aus dem RAM 4 zu laden und die darin enthaltene Klarschriftinformation (Fig. 1a, 1b) über den Inserter auf dem Bildschirm des Fernsehgerätes anzuzeigen.

Wird die Taste ein zweites Mal vom Benutzer gedrückt, so wird aus der im RAM 4 zwischengespeicher-

ten Zusatzinformation die Telefonnummer (Fig. 1a, 1b) in ein Modem übergeben und ein Wählvorgang ausgelöst. Vom Modem 5 führt eine entsprechende Telefonleitung aus der Empfangseinrichtung nach der Erfindung auf einen Telefonanschluß des Benutzers. Ist die Verbindung mit dem angewählten Teilnehmer hergestellt, werden bei einer Bestellinformation die Produktnummer (Fig. 1a) für das gewünschte Produkt zusammen mit einer Geräte-Nummer zur Identifikation des Benutzers aus einem PROM-Speicher übertragen. Enthält dagegen die Zusatzinformation eine Auswahlidentifikations-Nummer (Fig. 1b), so wird nur sie, ohne Geräte-Nummer, zur Wahrung der Anonymität des Benutzers dem angewählten Teilnehmer übermittelt.

Die erfolgreiche Übertragung der Daten wird vom Modern an die Steuerung signalisiert, die wiederum eine entsprechende Meldung an den Teletext-Dekoder zur Anzeige auf dem Bildschirm abgibt. Außerdem ist eine entsprechende Anzeige auf einer zugeordneten LED-Anzeige oder am Fernsehgerät bei einer eingebauten Empfangseinrichtung denkbar.

Kann dagegen vom Modem keine Verbindung hergestellt werden, so erfolgt eine Wiederholung des Wahlvorgangs nach einer Zeitspanne, die von einem Zufallsgenerator in der Steuerung bestimmt wird. Diese Vorgehensweise ist insbesondere zur zeitlichen Entzerrung von Anwahlwiederholungen notwendig, die auftreten können, wenn bei vielen Empfangseinrichtungen zum gleichen Zeitpunkt ein Bestellvorgang bzw. ein Auswahlvorgang vom Benutzer ausgelöst wird (beispielsweise bei einem Preisausschreiben "Die ersten zehn Anrufer gewinnen").

Zur Verdeutlichung der Erfindung werden die zeitlichen Aufeinanderfolgen der einzelnen Fernsehbeiträge mit den zugehörigen Zusatzinformationen und die möglichen Bestell- bzw. Auswahlmöglichkeiten näher in Fig. 3 und Fig. 4 gezeigt.

Fig. 3 (a) zeigt zwei aufeinanderfolgende Werbeprogramme "Spot A" und "Spot B". In Fig. 3 (b) sind die Zusatzinformationen "A" für "Spot A" und "B" für "Spot B" dargestellt, die beispielsweise alle $t_0 = 20$ sec. übertragen werden.

Das Eintreffen der Zusatzinformation und damit die Möglichkeit, direkt zu reagieren und das Angebot wahrzunehmen, wird dem Benutzer durch eine entsprechende Anzeige signalisiert, beispielsweise durch Eintasten eines Logogramms in das betreffende Programm. Wird dagegen keine Zusatzinformation beispielsweise für mehr als $t_1 = 30$ sec. von der Empfangseinrichtung detektiert, wird die Anzeige wieder gelöscht (Fig. 4 (a)).

Beim ersten Tastendruck des Benutzers (Fig. 4 (b)) wird die Klarschrift-Information aus der Zusatzinformation "A" in das laufende Werbeprogramm "Spot A" eingeblendet. Beim Eintreffen der Zusatzinformation "B" wechselt die Anzeige automatisch und es werden die zu "Spot B" gehörenden Klarschrift-Informationen angezeigt. Die Klarschrift-Information zu "Spot B" wird vom Bildschirm gelöscht, wenn nach dem ersten Tastendruck innerhalb von beispielsweise $t_2 = 100$ sec. kein zweiter Tastendruck erfolgt.

Um auszuschließen, daß bei einem unvorhergesehenen Wechsel der Zusatzinformation eine Bestellung des falschen Produkts bzw. eine falsche Auswahl erfolgt, ist vorgesehen, nach einem Wechsel für beispielsweise $t_3 = 2$ sec. einen etwaigen zweiten Tastendruck zur Auslösung des Bestellvorgangs bzw. der Auswahl zu ignorieren (Fig. 4 (c)).

Bei einem Bestellvorgang (Fig. 1a) erhält der ange-

wählte Teilnehmer (z. B. eine Kreditkartenorganisation) die Produkt-Nummer und die Geräte-Nummer; er identifiziert den Bestellenden anhand der Geräte-Nummer, gibt Adresse, Kontoverbindung und angefordertes Produkt an eine für die Auslieferung zuständige Stelle weiter und regelt ggf. die Bezahlung. Ein Auswahlvorgang (Fig. 1b) läuft ähnlich wie ein Bestellvorgang ab; es erfolgt nur keine Übermittlung der Geräte-Nummer zur Identifikation des Benutzers.

Ein erfolgreicher Bestell- bzw. Auswahlvorgang und eine erfolgreiche Übermittlung der Bestell- bzw. Auswahldaten wird dem Benutzer von der Empfangseinrichtung in geeigneter Weise angezeigt.

Anstelle einer fernsehmäßigen Übertragung der Zusatzinformation und deren Einblendung in ein Fernsehbild ist es ebensogut möglich, die Zusatzinformation in einem Hörfunk-Programmsignal zu übertragen und auf einem Display am Hörfunkempfänger wiederzugeben. Insbesondere eignet sich hierfür wegen der großen Übertragungskapazität ein digitales Hörfunk-Programmsignal. In Betracht kommt aber auch ein mit RDS-(Radio-Daten-System)-Signal versehenes analoges Hörfunk-Programmsignal (FM- und AM-Signal), da das RDS-Signal noch nichtbelegte Kennungen aufweist, welche für die erfindungsgemäße Zusatzinformation genutzt werden können.

Patentansprüche

1. Verfahren zum Wiedergeben von in einem Fernseh- oder Hörfunkprogrammsignal enthaltenen Zusatzinformationen, insbesondere in Form von Schrift und ggf. von Grafikelementen, welche innerhalb des Programmsignals in zeitlicher Korrelation zu dessen Programminhalt übertragen und empfängerseitig decodiert werden, dadurch gekennzeichnet, daß die empfangenen Zusatzinformationen empfängerseitig für eine bestimmte Dauer zwischengespeichert werden, daß auf einen ersten Befehl des Benutzers eine in der zuletzt empfangenen Zusatzinformation enthaltene Klarschrift und ggf. Grafikinformaton für eine bestimmte Zeitdauer wiedergegeben wird, und daß während der Wiedergabe der Klarschrift und ggf. der Grafikinformaton auf einen zweiten Befehl des Benutzers aus der zuletzt zwischengespeicherten Zusatzinformation eine der Klarschrift und ggf. Grafikinformaton zugeordnete Bestell- oder Auswahlinformation entnommen und an eine Wählvermittlungseinrichtung (z. B. Modem) weitergeleitet wird.
2. Verfahren nach Anspruch 1, dadurch gekennzeichnet, daß im Wiedergabebetrieb bei einem Wechsel der Zusatzinformationen die Auslösung des zweiten Befehls für eine bestimmte Zeitdauer gesperrt wird.
3. Verfahren nach Anspruch 1 oder 2, dadurch gekennzeichnet, daß die empfangsseitige Zwischenspeicherung einer Zusatzinformation dem Benutzer, zumindest für eine festgelegte Zeitdauer, optisch signalisiert wird.
4. Verfahren nach einem der Ansprüche 1 bis 3, dadurch gekennzeichnet, daß die Bestellinformation eine Produktkennung und eine Telekommunikationsnummer, ggf. in codierter Form, enthält, und daß die Wählvermittlungseinrichtung einen Wählvorgang entsprechend der Telekommunikationsnummer durchführt und bei aufgebauter Telekommunikationsverbindung die Produktkennung zu-

- sammen mit einer Benutzerkennung an den gerufenen Teilnehmer überträgt.
5. Verfahren nach Anspruch 4, dadurch gekennzeichnet, daß die entnommene Produktkennung und die entnommene Telekommunikationsnummer zwischengespeichert werden und daß die Benutzerkennung dauerhaft gespeichert ist. 5
6. Verfahren nach Anspruch 4 oder 5, dadurch gekennzeichnet, daß bei fehlerfreier Übertragung der Produkt- und der Benutzerkennung der gerufene Teilnehmer eine Quittiermeldung an die Wahlvermittlungseinrichtung rücküberträgt. 10
7. Verfahren nach Anspruch 6, dadurch gekennzeichnet, daß die rückübertragene Quittiermeldung an der Wiedergabeeinrichtung in geeigneter Weise angezeigt wird. 15
8. Verfahren nach Anspruch 6, dadurch gekennzeichnet, daß die rückübertragene Quittiermeldung eine optische und/oder akustische Signalisierung auslöst. 20
9. Verfahren nach einem der Ansprüche 4 bis 8, dadurch gekennzeichnet, daß bei erfolglosem Vermittlungsversuch oder bei fehlerhafter Übertragung der Produkt- und der Benutzerkennung die Wahlvermittlungseinrichtung einen erneuten Vermittlungs- und Übertragungsversuch nach einer Wartezeit durchführt, welche entsprechend einem Zufallsgesetz bestimmt wird. 25
10. Verfahren nach einem der Ansprüche 4 bis 9, dadurch gekennzeichnet, daß ein Wahlvorgang nur dann erfolgt, wenn die Benutzung der Wahlvermittlungseinrichtung vom berechtigten Benutzer freigegeben ist. 30
11. Verfahren nach einem der Ansprüche 1 bis 3, dadurch gekennzeichnet, daß die Auswahlinformation eine Auswahlidentifikation und eine Telekommunikationsnummer, ggf. in codierter Form, enthält, und daß die Wahlvermittlungseinrichtung einen Wahlvorgang entsprechend der Telekommunikationsnummer durchführt und bei aufgebauter Telekommunikationsverbindung die Auswahlidentifikation an den gerufenen Teilnehmer überträgt. 35
12. Verfahren nach Anspruch 11, dadurch gekennzeichnet, daß die entnommene Auswahlidentifikation und die entnommene Telekommunikationsnummer zwischengespeichert werden. 40
13. Verfahren nach Anspruch 11 oder 12, dadurch gekennzeichnet, daß bei fehlerfreier Übertragung der Auswahlidentifikation der gerufene Teilnehmer eine Quittiermeldung an die Wahlvermittlungseinrichtung rücküberträgt. 45
14. Verfahren nach Anspruch 13, dadurch gekennzeichnet, daß die rückübertragene Quittiermeldung an der Wiedergabeeinrichtung in geeigneter Weise angezeigt wird. 50
15. Verfahren nach Anspruch 13, dadurch gekennzeichnet, daß die rückübertragene Quittiermeldung eine optische und/oder akustische Signalisierung auslöst. 55
16. Verfahren nach einem der Ansprüche 11 bis 15, dadurch gekennzeichnet, daß erfolglosem Vermittlungsversuch oder bei fehlerhafter Übertragung der Auswahlidentifikation die Wahlvermittlungseinrichtung einen erneuten Vermittlungs- und Übertragungsversuch nach einer Wartezeit durchführt, welche entsprechend einem Zufallsgesetz bestimmt wird. 60
- 65

| |
|----------------------------------|
| |
| |
| Rotes Sommerkleid für 15.95 DM |
| |
| Produkt-Nummer Telefon-Nummer |

| |
|--|
| |
| |
| Umfrage: Gewinnt XYZ die nächste Wahl ?? |
| |
| Identifik.-Nr. Telefon-Nummer |

Fig. 1a

Fig. 1b

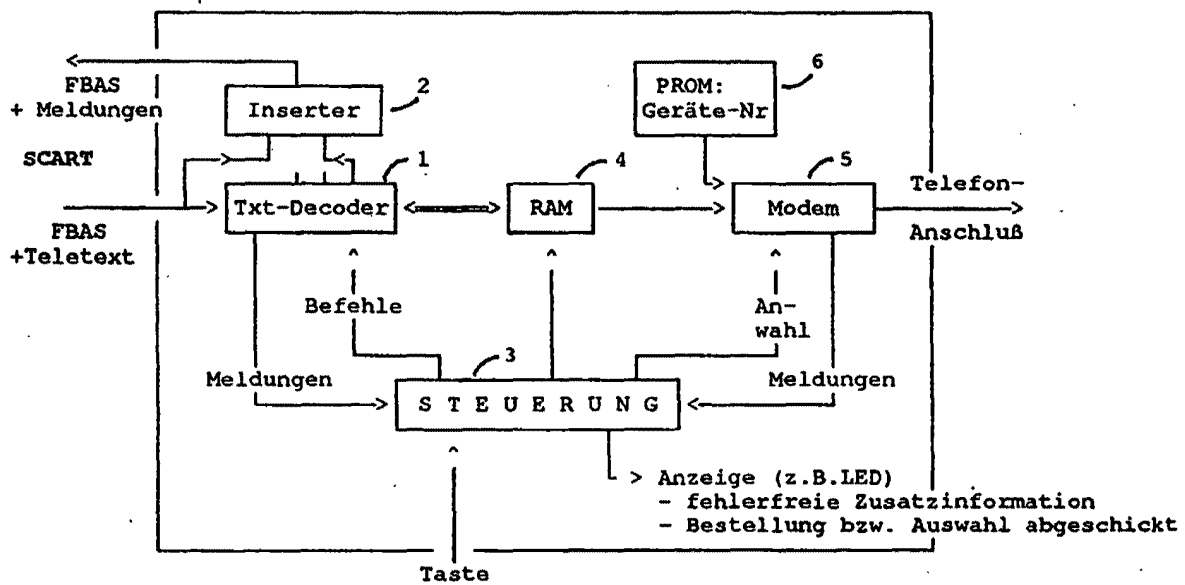

Fig. 2

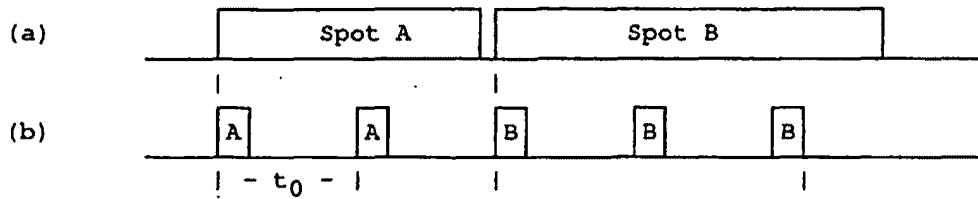

Fig. 3

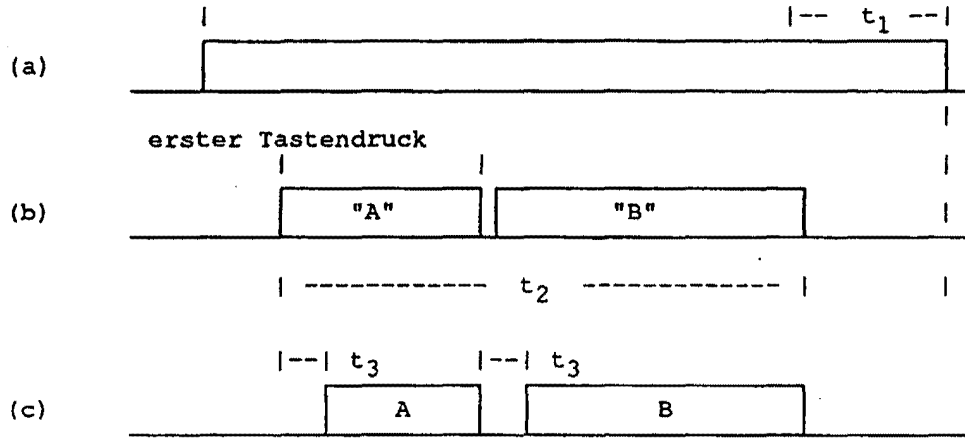

Fig. 4



19 BUNDESREPUBLIK
DEUTSCHLAND



DEUTSCHES
PATENTAMT

12 Offenlegungsschrift 10 DE 196 27 308 A 1

51 Int. Cl. 8:
H 04 M 1/00
H 04 M 11/06
H 04 L 9/32
G 07 F 19/00

21 Aktenzeichen: 196 27 308.0
22 Anmeldetag: 27. 6. 96
43 Offenlegungstag: 2. 1. 98

DE 196 27 308 A 1

71 Anmelder:
Mannesmann AG, 40213 Düsseldorf, DE

74 Vertreter:
P. Meissner und Kollegen, 14199 Berlin

72 Erfinder:
Mihatsch, Peter, Dr., 71069 Sindelfingen, DE

54 Kommunikationsgerät zur Übertragung von Buchungsbefehlen

57 Die Erfindung betrifft ein Kommunikationssystem zur Übertragung von Buchungsbefehlen, das untereinander zumindest virtuell vernetzte, zentrale und dezentrale Einrichtungen umfaßt, wobei an dezentralen Einrichtungen eingebaute, nutzerindividuelle Buchungsbefehle auf ihre Legitimation geprüft und an zentrale Einrichtungen zur Verarbeitung weitergeleitet werden.

Die Erfindung ist dadurch gekennzeichnet,

- daß Mittel eines unabhängigen zweiten Kommunikationssystems (2) mit ortsfesten Einrichtungen (21, 22/1, 22/2) und mit diesen verschlüsselt kommunizierenden, tragbaren Kommunikationseinrichtungen (23) vorgesehen sind,
- daß die ortsfesten Einrichtungen (21, 22/1, 22/2) des zweiten Kommunikationssystems (2) mit den zentralen Einrichtungen (11) des ersten Kommunikationssystems (1) zumindest temporär verbindbar sind,
- daß mit den tragbaren Kommunikationseinrichtungen (23) des zweiten Kommunikationssystems (2) nutzerindividuelle Buchungsbefehle in einer der zentralen Einrichtungen (11) des ersten Kommunikationssystems (1) vorlegitimierbar sind,
- daß ein vorlegitimierter verschlüsselter Buchungscodex zumindest temporär in der tragbaren Kommunikationseinrichtungen (23) des zweiten Kommunikationssystems (2) speicherbar ist und
- daß der vorlegitimierte verschlüsselte Buchungscodex unabhängig vom ersten und zweiten Kommunikationssystem (1, 2) zur tatsächlichen Buchung an eine dezentrale Einrichtung (12/1 bis 12/3) des ersten Kommunikationssystems (1)

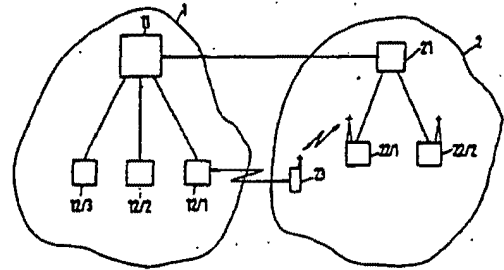

DE 196 27 308 A 1

Die folgenden Angaben sind den vom Anmelder eingereichten Unterlagen entnommen

BUNDESDRUCKEREI 10. 97 702 051/720

5/25

Beschreibung

Die Erfindung betrifft ein Kommunikationssystem zur Übertragung von Buchungsbefehlen nach dem Oberbegriff des Patentanspruchs 1.

Derartige Kommunikationssysteme sind durch offenkundige Vorbenutzung bekannt.

Dazu ist eine Vielzahl von geldwerten Chipkarten, wie Telefonkarten, Kundenkarten, Kreditkarten usw. im Umlauf, die durch temporäres Einfügen in eine von einer zentralen Buchungseinrichtung örtlich abgesetzten dezentralen Einrichtung zur Bezahlung einer Ware oder Dienstleistung geeignet sind. Nachteiligerweise sind diese geldwerten Chipkarten regelmäßig von enger Zweckbindung, beispielsweise sind Telefonkarten ausschließlich zum Telefonieren unter Nutzung von Endgeräten eines einzigen Telefonunternehmens geeignet, und in Verbindung mit dezentralen Einrichtungen unterschiedlichen Komforts benutzbar. Darüber hinaus ist das Abhandenkommen einer derartigen geldwerten Chipkarte regelmäßig von monetärem Verlust begleitet. Weiterhin unterliegen diese Chipkarten aus Haftungsgründen betragsmäßigen Wertbeschränkungen, die ihre Brauchbarkeit weitgehend limitieren.

Darüber hinaus ist unter dem Begriff des sogenannten "Homebanking" ein Kommunikationssystem zur Übertragung von Buchungsbefehlen bekanntgeworden, bei dem der Benutzer dieses System unter Verwendung eines Personalcomputers mit Modem über eine Telefonverbindung Buchungsbefehle an eine zentrale Buchungseinrichtung überträgt. Die dazu erforderlichen technischen Einrichtungen sind nur eingeschränkt transportabel. Darüber hinaus ermangelt es diesem Verfahren an der Möglichkeit der Barauszahlung. Weiterhin sind die Vorkehrungen zum Schutz gegen unlegitimier- te Zugriffe zumindest lückenhaft.

Der Erfindung liegt daher die Aufgabe zugrunde, ein Kommunikationssystem der gattungsgemäßen Art anzugeben, das einen komfortablen Zugriff bei höchstmöglicher Sicherheit gegen unlegitimierten Zugriff sowie eine breite Akzeptanz ermöglicht.

Erfindungsgemäß wird diese Aufgabe mit den Mitteln des Patentanspruchs 1 gelöst. Vorteilhafte Ausgestaltungen der Erfindung sind in den Patentansprüchen 2 bis 6 beschrieben.

Die Erfindung geht dabei von einem für sich bekannten Kommunikationssystem zur Übertragung von Buchungsbefehlen aus, das untereinander zumindest virtuell vernetzte, zentrale und dezentrale Einrichtungen umfaßt wobei die an den dezentralen Einrichtungen ein- gebbaren, nutzerindividuellen Buchungsbefehle auf ihre Legitimation geprüft und an zentrale Einrichtungen zur Verarbeitung weitergeleitet werden.

Der Kern der Erfindung besteht darin, daß ein unabhängiges zweites Kommunikationssystem vorgesehen ist, das aus ortsfesten Einrichtungen und mit diesen verschlüsselt kommunizierenden, tragbaren Kommunikationsend- einrichtungen besteht. Dabei sind die ortsfesten Einrichtungen des zweiten Kommunikationssystems mit den zentralen Einrichtungen des Kommunikationssystems zur Übertragung von Buchungsbefehlen zumindest temporär verbindbar. Mit den tragbaren Kommunikationsend- einrichtungen des zweiten Kommunikationssystems sind nutzerindividuelle Buchungsbefehle in einer der zentralen Einrichtungen des Kommunikationssystems zur Übertragung von Buchungsbefehlen vorlegitimierbar. Weiterhin ist vorgesehen, daß ein vorlegitimierter, verschlüsselter Buchungscode zumindest

temporär in der tragbaren Kommunikationsend- einrichtung des zweiten Kommunikationssystems speicherbar ist und daß der vorlegitimierter verschlüsselte Buchungscode unabhängig vom ersten und vom zweiten Kommunikationssystem zur tatsächlichen Buchung an eine dezentrale Einrichtung des ersten Kommunikationssystems übertragbar ist.

Ein durch einen Nutzer initiiertes Buchungsbefehl wird mit den Mitteln der tragbaren Kommunikations- endeinrichtung des zweiten Kommunikationssystems eingegeben. Dazu ist die tragbare Kommunikationsend- einrichtung mit einer Tastatur und vorzugsweise einer Anzeigevorrichtung ausgestattet. Der Buchungsbefehl wird innerhalb des zweiten Kommunikationssystems mit der dem zweiten Kommunikationssystem immanen- ten Verschlüsselung zu einer ortsfesten Einrichtung des zweiten Kommunikationssystems übertragen und an eine zentrale Einrichtung des Kommunikationssystems zur Übertragung von Buchungsbefehlen weitergeleitet.

Der Zugang des Nutzers zur Diensten des zweiten Kommunikationssystems ist durch einen mehrstufigen Identifizierungsprozeß gegen unlegitimierter Zugriffe abgesichert. Dazu werden seitens der ortsfesten Ein- richtungen des zweiten Kommunikationssystems die Endgerätenummer der tragbaren Kommunikationsend- einrichtung, die Teilnehmernummer des Nutzers, die auf einem wechselbaren Modul innerhalb der tragbaren Kommunikationsend- einrichtung gespeichert ist, und die persönliche Identifikationsnummer des Nutzers abge- fragt. Infolge dieses mehrstufigen Identifizierungspro- zesses gilt der unlegitimierter Zugang zum zweiten Kommunikationssystem bei bestimmungsgemäßem Ge- brauch als ausgeschlossen. Vorzugsweise ist das zweite Kommunikationssystem ein Mobilkommunikationssy- stem auf der Basis des GSM-Standards.

Vorteilhafterweise wird bei höchstmöglicher Sicher- heit gegen unlegitimierter Zugriffe ein hoher Grad an Komfort realisiert, da bekannte tragbare Kommunika- tionsend- einrichtungen so geringe Volumina aufweisen, daß sie ständig mitgeführt werden können.

Als zusätzlicher positiver Effekt ist anzusehen, daß mit einem einzigen mitzuführenden Gerät, das zum Zwecke der verbalen und Daten-Kommunikation ohne- hin bereits eine weite Verbreitung gefunden hat, ergän- zend Buchungsgeschäfte durchführbar sind.

Die Erfindung wird nachstehend anhand eines Aus- führungsbeispiels unter Berücksichtigung von vorteil- haften Ausgestaltungen näher erläutert.

In der einzigen Figur sind ein Kommunikationssystem 1 zur Übertragung von Buchungsbefehlen mit einer zentralen Einrichtung 11 und drei dezentralen Einrich- tungen 12/1 bis 12/3 dargestellt, die derart miteinander vernetzt sind, daß jede dezentrale Einrichtung 12/1 bis 12/3 mit der zentralen Einrichtung 11 verbunden ist. Diese Verbindung kann dauerhaft oder auch auf Anfor- derung temporär geschaltet sein.

Weiterhin ist ein zweites Kommunikationssystem 2 mit ortsfesten Einrichtungen 21, 22/1 und 22/2 und tra- gbaren Kommunikationsend- einrichtungen 23 dargestellt, das als Mobilkommunikationssystem ausgeführt ist. Da- bei sind die ortsfesten Einrichtungen 21, 22/1 und 22/2 permanent miteinander verbunden. Bestimmungsgemäß wird bedarfsweise eine Verbindung zwischen der tragbaren Kommunikationsend- einrichtung 23 und einer der ortsfesten Einrichtungen 22/1 und 22/2 hergestellt, die eine Funkverbindung mit verschlüsselter Daten- übertragung ist.

Die ortsfeste Einrichtung 21 des Kommunikationssy-

stems 2 ist mit der zentralen Einrichtung 11 des Kommunikationssystems 1 zur Übertragung von Buchungsbefehlen verbunden. Diese Verbindung kann permanent oder auf Anforderung temporär geschaltet sein.

Ein nutzerindividueller Buchungsbefehl wird auf der Tastatur der tragbaren Kommunikationseinrichtung 23 eingegeben und über die ortsfesten Einrichtungen 22/1 und 21 des Mobilkommunikationssystems 2 an die zentrale Einrichtung 11 des Kommunikationssystems 1 zur Übertragung von Buchungsbefehlen übertragen. Bei vorliegender Zugangsvoraussetzung des Nutzers zum Kommunikationssystem 1 zur Übertragung von Buchungsbefehlen wird der empfangene Buchungsbefehl mit der zentralen Einrichtung 11 vorlegitimiert und als vorlegitimierter Buchungscode über die ortsfesten Einrichtungen 21 und 22/1 des Mobilkommunikationssystems an die tragbare Kommunikationseinrichtung 23 übertragen und in der tragbaren Kommunikationseinrichtung zumindest temporär zwischengespeichert.

Da die Legitimation des Nutzers bereits beim Zugang zum Mobilkommunikationssystem 2 mehrstufig geprüft wird, ist vorteilhafterweise eine zusätzliche Legitimation des Nutzers gegenüber der zentralen Einrichtung 11 des Kommunikationssystems 1 zur Übertragung von Buchungsbefehlen entbehrlich. Dabei ist als weiterer Vorteil anzusehen, daß sich die Anzahl der durch den Nutzer zu merkenden Zugangs- und Identifizierungsschlüssel verringert, wodurch die Gefahr von Verwechslungen und Fehlidentifizierungen sinkt. Dieses Merkmal ist insbesondere im Hinblick auf die in üblichen Systemen sicherheitstechnisch begründete, eng begrenzte Anzahl von Zugangsversuchen bedeutsam.

Zur tatsächlichen Erlangung einer Ware oder Dienstleistung wird der vorlegitimierte, verschlüsselte Buchungscode, der in der tragbaren Kommunikationseinrichtung 23 zwischengespeichert ist, unabhängig vom ersten und zweiten Kommunikationssystem 1 und 2 zur tatsächlichen Buchung an eine dezentrale Einrichtung 12/1 des Kommunikationssystems 1 zur Übertragung von Buchungsbefehlen übertragen.

Dazu ist vorgesehen, daß die tragbare Kommunikationseinrichtung 23 des Mobilkommunikationssystems und die dezentrale Einrichtung 12/1 des Kommunikationssystems 1 zur Übertragung von Buchungsbefehlen über eine drahtlose, kurzreichweitige Kommunikationsanordnung untereinander verbindbar sind, wobei die tragbare Kommunikationseinrichtung 23 mindestens mit Sendemitteln und die dezentrale Einrichtung 12/1 mindestens mit Empfangsmitteln ausgestattet ist.

In vorteilhafter Ausgestaltung der Erfindung ist diese drahtlose, kurzreichweitige Kommunikationsanordnung durch eine Infrarotverbindung dargestellt. Die dazu erforderlichen technischen Mittel zeichnen sich vorteilhafterweise durch sehr geringe Volumina und Versorgungsanforderungen aus, so daß diese vorteilhaft in bekannte tragbare Kommunikationseinrichtungen integrierbar sind.

In alternativer Ausgestaltung der drahtlosen, kurzreichweitigen Kommunikationsanordnung ist vorgesehen, diese als Ultraschallverbindung auszuführen. Die dazu erforderlichen technischen Mittel weisen dieselben vorteilhaften Eigenschaften wie die Infrarotverbindung auf.

In weiterer Ausgestaltung der Erfindung ist vorgesehen, daß der vorlegitimierte, verschlüsselte Buchungscode entsprechend den Algorithmen im Verkehr zwi-

schen den zentralen und dezentralen Einrichtungen 11 und 12/1 bis 12/3 verschlüsselt ist.

Vorteilhafterweise ist der an die dezentrale Einrichtung 12/1 übertragene Buchungscode durch die dezentrale Einrichtung 12/1 direkt verarbeitbar, so als wäre er von der zentralen Einrichtung 11 desselben Kommunikationssystems 1 übertragen worden.

In weiterführender Ausgestaltung der Erfindung ist vorgesehen, den vorlegitimierten verschlüsselten Buchungscode entsprechend den Algorithmen im Verkehr zwischen den ortsfesten Einrichtungen 21, 22/1 und 22/2 und den mit diesen verschlüsselt kommunizierenden, tragbaren Kommunikationseinrichtungen 23 des Mobilkommunikationssystems 2 verschlüsselt zu übertragen. Mit anderen Worten ist der vorlegitimierte Buchungscode, der bereits unter Anwendung von Mitteln im Kommunikationssystem 1 zur Übertragung von Buchungsbefehlen gemäß diesem System verschlüsselt ist, während seiner Übertragung innerhalb des Mobilkommunikationssystems 2 ein weiteres Mal, also überlagert verschlüsselt.

Vorteilhafterweise wird durch diese doppelte Verschlüsselung der unlegitimierte Zugang zu vorlegitimierten Buchungscodes zumindest erheblich erschwert, so daß aufgrund der weitgehenden Sicherheitsvorkehrungen eine breite Akzeptanz ermöglicht wird.

Bezugszeichenliste

- 1 Kommunikationssystem zur Übertragung von Buchungsbefehlen
- 11 zentrale Einrichtung
- 12/1 bis 12/3 dezentrale Einrichtungen
- 2 zweites Kommunikationssystem
- 21, 22/1, 22/2 ortsfeste Einrichtungen
- 23 tragbare Kommunikationseinrichtung

Patentansprüche

1. Kommunikationssystem zur Übertragung von Buchungsbefehlen, das untereinander zumindest virtuell vernetzte, zentrale und dezentrale Einrichtungen umfaßt wobei an dezentralen Einrichtungen eingebaute, nutzerindividuelle Buchungsbefehle auf ihre Legitimation geprüft und an zentrale Einrichtungen zur Verarbeitung weitergeleitet werden, dadurch gekennzeichnet,
 - daß Mittel eines unabhängigen zweiten Kommunikationssystems (2) mit ortsfesten Einrichtungen (21, 22/1, 22/2) und mit diesen verschlüsselt kommunizierenden, tragbaren Kommunikationseinrichtungen (23) vorgesehen sind,
 - daß die ortsfesten Einrichtungen (21, 22/1, 22/2) des zweiten Kommunikationssystems (2) mit den zentralen Einrichtungen (11) des ersten Kommunikationssystems (1) zumindest temporär verbindbar sind,
 - daß mit den tragbaren Kommunikationseinrichtungen (23) des zweiten Kommunikationssystems (2) nutzerindividuelle Buchungsbefehle in einer der zentralen Einrichtungen (11) des ersten Kommunikationssystems (1) vorlegitimierbar sind,
 - daß ein vorlegitimierter verschlüsselter Buchungscode zumindest temporär in der tragbaren Kommunikationseinrichtungen (23) des zweiten Kommunikationssystems (2) spei-

cherbar ist und

– daß der vorlegitierte verschlüsselte Buchungscode unabhängig vom ersten und zweiten Kommunikationssystem (1, 2) zur tatsächlichen Buchung an eine dezentrale Einrichtung (12/1 bis 12/3) des ersten Kommunikationssystems (1) übertragbar ist.

2. Kommunikationssystem nach Anspruch 1, dadurch gekennzeichnet, daß die Kommunikations-einrichtungen (23) des zweiten Kommunikationssystems (2) und die dezentrale Einrichtung (12/1 bis 12/3) des ersten Kommunikationssystems (1) über eine drahtlose, kurzreichweitige Kommunikationsanordnung miteinander verbindbar sind, wobei die Kommunikations-einrichtungen (23) mindestens mit Sendemitteln und die dezentrale Einrichtung (12/1 bis 12/3) mindestens mit Empfangsmitteln ausgestattet ist.

3. Kommunikationssystem nach Anspruch 2, dadurch gekennzeichnet, daß die drahtlose, kurzreichweitige Kommunikationsanordnung durch eine Infrarotverbindung dargestellt ist.

4. Kommunikationssystem nach Anspruch 2, dadurch gekennzeichnet, daß die drahtlose, kurzreichweitige Kommunikationsanordnung durch eine Ultraschallverbindung dargestellt ist.

5. Kommunikationssystem nach Anspruch 1, dadurch gekennzeichnet, daß der vorlegitierte verschlüsselte Buchungscode entsprechend den Algorithmen im Verkehr zwischen den zentralen und dezentralen Einrichtungen (11 und 12/1 bis 12/3) verschlüsselt ist.

6. Kommunikationssystem nach den Ansprüchen 1 und 5, dadurch gekennzeichnet, daß der vorlegitierte verschlüsselte Buchungscode entsprechend den Algorithmen im Verkehr zwischen den ortsfesten Einrichtungen (21, 22/1, 22/2) und mit diesen verschlüsselt kommunizierenden, tragbaren Kommunikations-einrichtungen (23) des zweiten Kommunikationssystems (2) verschlüsselt übertragbar ist.

Hierzu 1 Seite(n) Zeichnungen

45

50

55

60

65

- Leerseite -

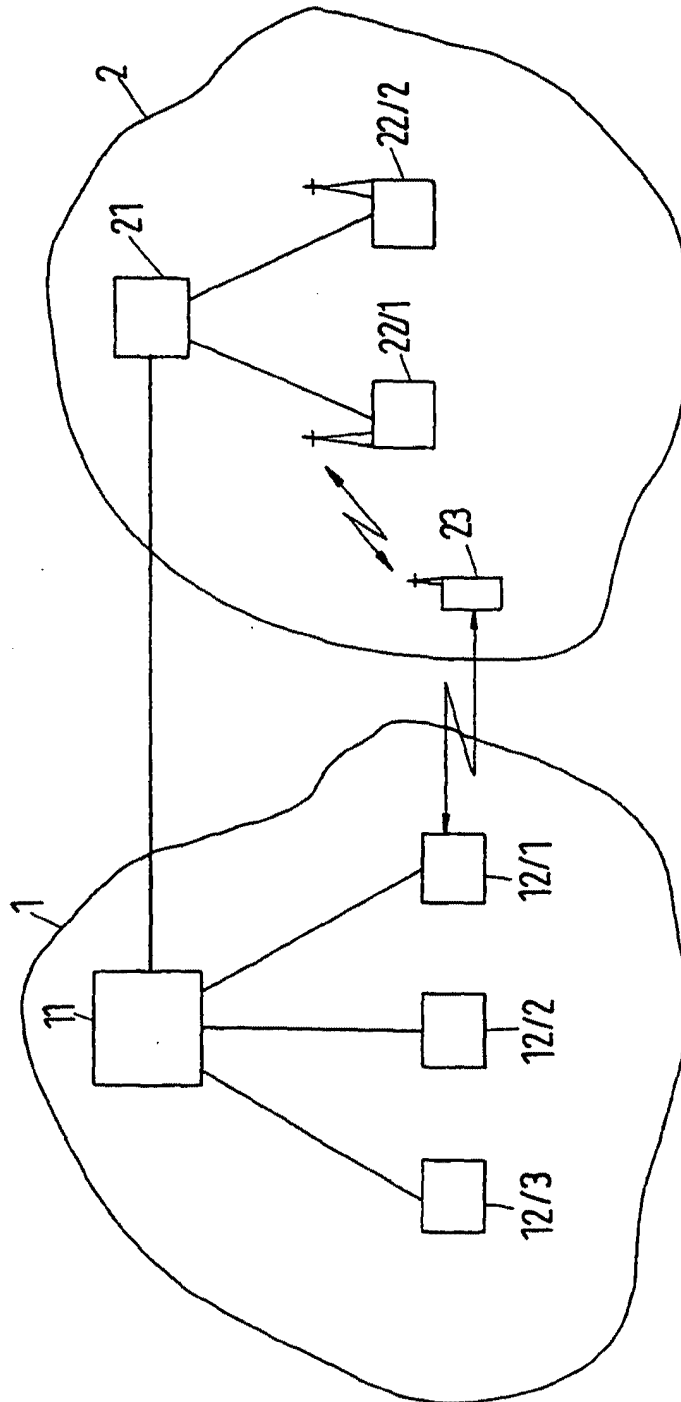

702 061/720

(19) 日本国特許庁 (JP)

(12) 公開特許公報 (A)

(11) 特許出願公開番号

特開平10-135855

(43) 公開日 平成10年(1998) 5月22日

| (51) Int.Cl. ⁸ | 識別記号 | F I | |
|---------------------------|-------|---------|--------------|
| H 0 4 B | 1/16 | H 0 4 B | 1/16 G |
| H 0 4 H | 1/00 | H 0 4 H | 1/00 C |
| | 1/02 | | E |
| H 0 4 Q | 9/00 | | 1/02 F |
| | 3 0 1 | H 0 4 Q | 9/00 3 0 1 E |

審査請求 未請求 請求項の数11 OL (全 4 頁)

(21) 出願番号 特願平8-286982
 (22) 出願日 平成8年(1996)10月29日

(71) 出願人 000002185
 ソニー株式会社
 東京都品川区北品川6丁目7番35号
 (72) 発明者 近藤 哲二郎
 東京都品川区北品川6丁目7番35号 ソニ
 ー株式会社内
 (72) 発明者 奥村 裕二
 東京都品川区北品川6丁目7番35号 ソニ
 ー株式会社内

(54) 【発明の名称】 情報受信装置及び情報送信装置並びに情報伝送方法

(57) 【要約】

【課題】 音声放送等に種々のデータを多重化することにより、受信端末装置の制御等を可能とする。

【解決手段】 放送局から放送電波に、放送中の映像又は音声信号の識別コード、演奏時間、著作権所有者、販売価格、又は、販売元等の付加情報を多重化して伝送する。そしてこの伝送された付加情報を受信した者は、必要に応じて、所定の手続きで、放送中の映像信号等の販売事業者から映像等のソースを購入する。

【効果】 受信者において、所望の楽曲等の購入にかかる費用等が付加情報により確認できるほか、通信回線による販売事業者等への接続や、発注等にかかる作業負担を、付加情報の利用で軽減できる。

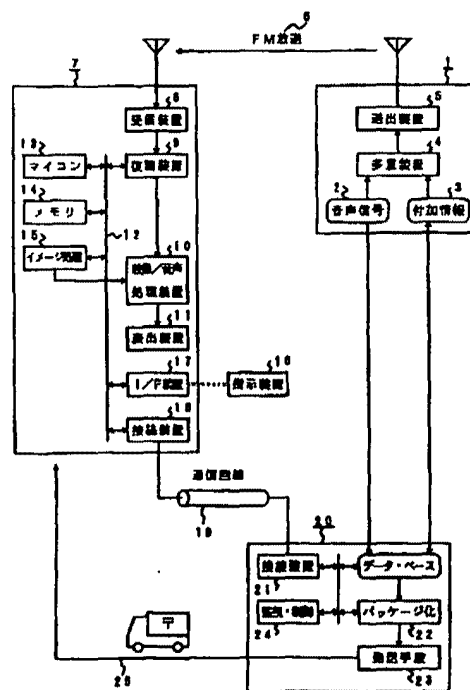

【特許請求の範囲】

【請求項1】 放送局から放送電波に多重化して送信される情報を受信する情報受信装置であって、前記多重化して送信される情報は、放送中の映像又は音声信号の付加情報であることを特徴とする情報受信装置。

【請求項2】 請求項1記載の情報受信装置であって、前記付加情報は、前記放送中の映像又は音声信号の識別コード、演奏時間、著作権所有者、販売価格、又は、販売元であることを特徴とする情報受信装置。

【請求項3】 放送電波に多重化して情報を送信する情報送信装置であって、前記多重化して送信する情報は、放送中の映像又は音声信号の付加情報であることを特徴とする情報送信装置。

【請求項4】 請求項3記載の情報送信装置であって、前記付加情報は、前記放送中の映像又は音声信号の識別コード、演奏時間、著作権所有者、販売価格、又は、販売元であることを特徴とする情報送信装置。

【請求項5】 請求項1記載の情報受信装置であって、前記情報受信装置は、前記放送中の映像又は音声信号のソースを販売する事業者と情報の授受を行うための通信手段を有することを特徴とする情報受信装置。

【請求項6】 請求項2記載の情報受信装置であって、前記情報受信装置は、前記放送中の映像又は音声信号のソースを販売する事業者と情報の授受を行うための通信手段を有することを特徴とする情報受信装置。

【請求項7】 請求項5記載の情報受信装置であって、更に、前記付加情報を記憶する手段と、前記記憶した付加情報を編集し発注用データを作成するデータ作成手段とを有することを特徴とする情報受信装置。

【請求項8】 放送局から放送電波に多重化して情報を伝送する情報伝送方法であって、前記多重化して伝送する情報は、放送中の映像又は音声信号の付加情報であることを特徴とする情報伝送方法。

【請求項9】 請求項8記載の情報伝送方法であって、前記付加情報は、前記放送中の映像又は音声信号の識別コード、演奏時間、著作権所有者、販売価格、又は、販売元であることを特徴とする情報伝送方法。

【請求項10】 請求項8記載の情報伝送方法であって、前記付加情報を一時的に記憶し、前記記憶した付加情報の履歴に基づいて伝送された信号を編集し選択する編集工程を有することを特徴とする情報伝送方法。

【請求項11】 請求項10記載の情報伝送方法であって、更に、前記編集工程の結果を基に映像又は音声信号のソースを配布する工程を有することを特徴とする情報伝送方法。

【発明の詳細な説明】

【0001】

【発明の属する技術分野】本発明は、映像／音声信号にデータを多重化して放送するシステムに関する。

【0002】

【従来の技術】従来、FMラジオ放送等において、FM多重データ放送が行われていた。これは、特開平8-149023号公報に記載されているように、通常のFM番組音声信号に多重化して、その番組と連動した文字情報等を放送するものである。

10 【0003】

【発明が解決しようとする課題】しかし、従来のFM多重データ放送は、文字コードの伝送による、受信装置における情報の文字表示を目的としており、伝送されたデータにより受信端末装置の制御を行う等のサービス形態はこれまでなかった。

【0004】本発明の課題は、音声放送等に種々のデータを多重化することにより、受信端末装置の制御等を可能とする情報受信装置及び情報送信装置並びに情報伝送方法を提供することである。

20 【0005】

【課題を解決するための手段】上記目的を達成するために、本発明の情報受信装置は、放送局から放送電波に、放送中の映像又は音声信号の識別コード、演奏時間、著作権所有者、販売価格、又は、販売元等の付加情報を多重化して送信される情報を受信するものである。上記目的を達成するために、本発明の情報送信装置は、放送電波に、放送中の映像又は音声信号の識別コード、演奏時間、著作権所有者、販売価格、又は、販売元等の付加情報を多重化して送信するものである。上記目的を達成するために、本発明の情報伝送方法は、放送電波に、放送中の映像又は音声信号の識別コード、演奏時間、著作権所有者、販売価格、又は、販売元等の付加情報を多重化して伝送するものである。

【0006】

【発明の実施の形態】以下、本発明を図面を参照して具体的に説明する。図1は、本発明の好ましい実施の形態を示すブロック図である。放送局1は、通常のFMラジオ放送である音声による音声信号2に、例えば、現在放送している楽曲の識別コード、演奏時間、著作権所有者、販売価格、販売事業者等のデータからなる付加情報3を、主たる音声信号2を受信する上で妨害を与えぬよう、例えば、FM文字多重放送のように受信端末で分離可能な方式により、多重装置4にて多重化した後、送出装置5より放送信号として送出する。送出されたFM放送信号は、放送手段6により受信端末装置7に供給される。

【0007】受信端末装置7の受信装置8により受信された放送信号は、復調装置9において、通常のFMラジオ放送信号に関しては、映像／音声処理装置10において音声処理された後、表出装置11の、例えば、スピー

カ等からなる音声表出手段により、受信者（図示せず）に供給される。

【0008】他方、音声信号に多重、重畳された付加情報3は、復調装置9において所定の信号形式に複合化された後、バス12を介し、マイクロプロセッサ13に供給される。マイクロプロセッサ13は、受信者（図示せず）が指示装置16の操作により送信した制御命令を受信するインターフェース装置17や、受信した番組付加情報データを一時格納するメモリ14、番組付加情報データを映像/音声化するイメージ処理装置15、販売事業者20と通信回線19とバス12を介して接続されている。

【0009】いま、受信者（図示せず）が、表出装置11より表出される音声番組中の楽曲を聴き、この楽曲或いは、例えば、演奏者等が異なる等の派生形態に関し、CDや磁気録音メディア等のパッケージメディアの形態での購入、或いは、通信回線19を介して、蓄積装置（図示せず）への配信を希望した場合、以下の操作及び手続きを行う。

【0010】まず、受信者（図示せず）は、希望する楽曲の購入価格、演奏時間、派生形態の有無等を付加情報から得るため、指示装置16の操作によりマイクロプロセッサ13に指令を出し、これらの情報を認識可能な形態で表出装置11に表示させる。ここで、マイクロプロセッサ13は、付加情報のメモリ14への格納と、複数の楽曲にかかる演奏時間、購入価格等を蓄積する演算処理や、放送による演奏順序によらず受信者が意図する順序への並べ替え、選択楽曲の削除といった編集作業を行うという処理機能をあわせて有し、受信者の指令によりこれを行う。

【0011】購入を希望する単一の楽曲或いは複数の楽曲からなるパッケージの選択、編集作業を終了した後、受信者の指示装置16による指示を受け、マイクロプロセッサ13は、付加情報中の販売事業者20に関する情報を基に、接続装置18を操作し、通信回線19を介してこれと接続し、受信者情報を含む購入依頼データを送信する。

【0012】販売事業者20は、接続装置21を介して受けた購入依頼のデータを基に、楽曲及びそれに付随する情報が蓄積されたデータベースを検索及び操作し、該当する楽曲をパッケージ化手段22によりCDや磁気録

音メディア等のパッケージメディア化し、発送手段23を経た後、郵送等の配信手段25にて受信者に供給する。これらのデータの流は、監視・制御手段24によって監視され、制御される。但し、受信者が希望した楽曲の組み合わせが、いわゆる楽曲集の形態で販売事業者20等が予め提示し、パッケージ化した物と一致する場合には、新たなパッケージ化は行わない。パッケージによる供給の他、受信者の希望によっては、接続装置21、通信回線19を介し、楽曲データとして受信者に配信する。

【0013】尚、上記発明の実施の形態では、FM放送の場合のみを示したが、本発明に係る情報受信装置及び情報送信装置並びに情報伝送方法はこれに限るものでなく、AM放送、デジタル放送等の任意の放送形態であってもよいことはいうまでもない。

【0014】

【発明の効果】以上の説明から明らかなように、本発明の情報受信装置及び情報送信装置並びに情報伝送方法によれば、FM放送等にデータを多重化することにより、受信者において、所望の楽曲等の購入にかかる費用等が付加情報により確認できるほか、通信回線による販売事業者等への接続や、発注等にかかる作業負担を、付加情報の利用で軽減でき、これにより、現に受信している楽曲を鍵に、選択、発注を行うため、楽曲等の取扱商品のデータベースや検索システムを受信者側において持つ必要がなくなる他、個人レベルで行われていた複数のCDからのテープ編集を事業者側に一本化して行うことが可能となる。

【図面の簡単な説明】

【図1】 本発明の好ましい実施の形態を示すブロック図である。

【符号の説明】

- 1…放送局、2…音声信号、3…付加情報、4…多重装置、5…送出装置、6…放送手段、7…受信端末装置、8…受信装置、9…復調装置、10…映像/音声処理装置、11…表出装置、12…バス、13…マイクロプロセッサ、14…メモリ、15…イメージ処理装置、16…指示装置、17…インターフェース装置、18…接続装置、19…通信回線、20…販売事業者、21…接続装置、22…パッケージ化手段、23…発送手段、24…監視・制御手段、25…配信手段

【図1】

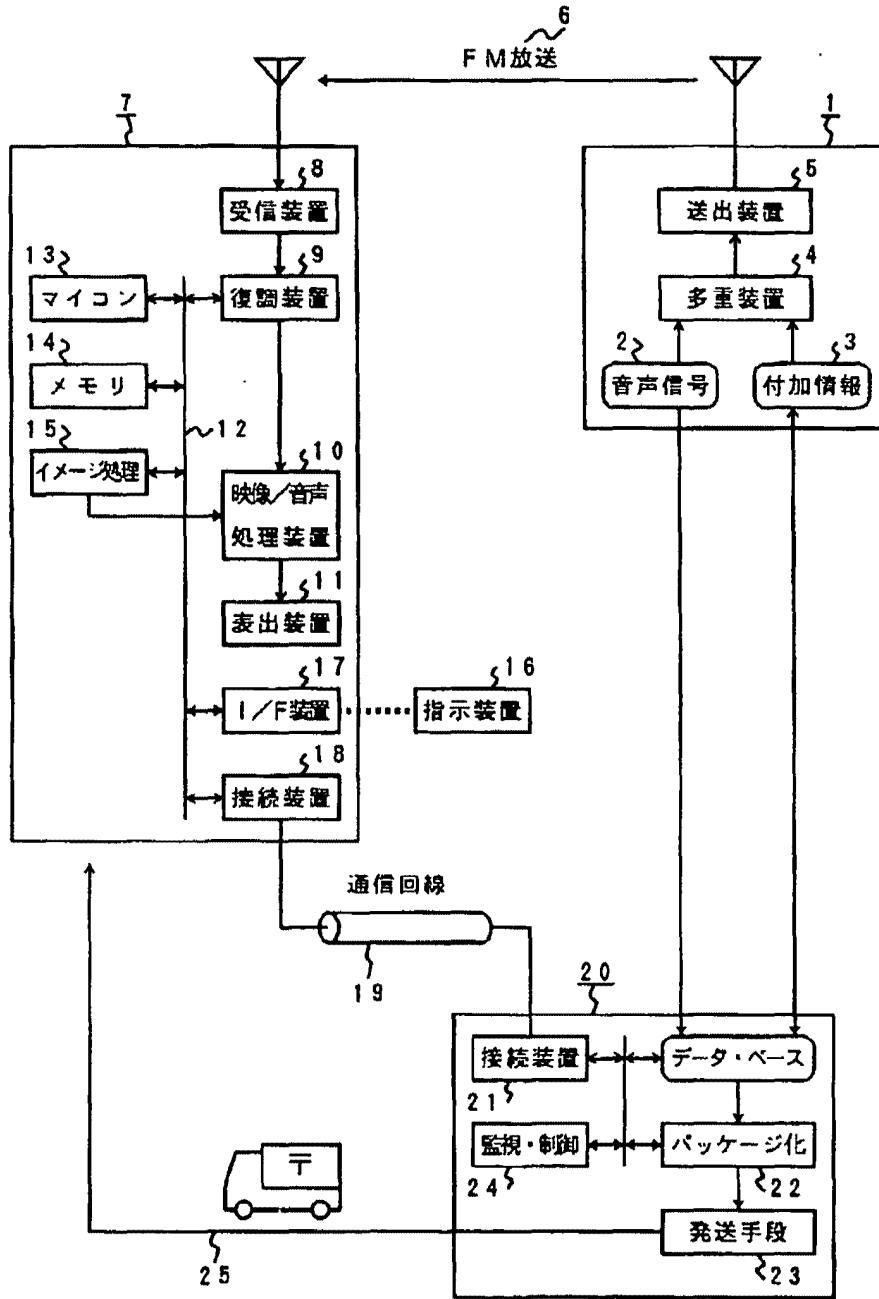

DERWENT-ACC-NO: 1998-354040
DERWENT-WEEK: 199831
COPYRIGHT 1999 DERWENT INFORMATION LTD

TITLE: Information receiver for FM radio data broadcast - receives audio signal along with additional information multiplexed and transmitted from FM broadcast station

PATENT-ASSIGNEE: SONY CORP[SONY]

PRIORITY-DATA: 1996JP-0286982 (October 29, 1996)

PATENT-FAMILY:

| PUB-NO | PUB-DATE | LANGUAGE | PAGES |
|---------------|--------------|----------|-------|
| MAIN-IPC | | | |
| JP 10135855 A | May 22, 1998 | N/A | 004 |
| H04B 001/16 | | | |

APPLICATION-DATA:

| PUB-NO | APPL-DESCRIPTOR | APPL-NO |
|------------------|-----------------|----------------|
| APPL-DATE | | |
| JP10135855A | N/A | 1996JP-0286982 |
| October 29, 1996 | | |

INT-CL_(IPC): H04B001/16; H04H001/00 ; H04H001/02 ; H04Q009/00

ABSTRACTED-PUB-NO: JP10135855A

BASIC-ABSTRACT: The information receiver (7) receives a broadcast electric wave transmitted by an FM radio broadcasting station (1). This broadcast station multiplexes various additional information such as identification code of audio signal, selling price and agency, copy write owner to the audio signal and transmits the multiplexed signal. This transmitted information is sent to a selling agent (20) who responds in response to the obtained information.

ADVANTAGE - Reduces work load by providing additional information. Avoids use of database and searching systems for handling goods.

CHOSEN-DRAWING: Dwg.1/1

TITLE-TERMS:

INFORMATION RECEIVE FM RADIO DATA BROADCAST RECEIVE AUDIO SIGNAL ADD INFORMATION MULTIPLEX TRANSMIT FM BROADCAST STATION

DERWENT-CLASS: W03

EPI-CODES: W03-B08;

SECONDARY-ACC-NO:

Non-CPI Secondary Accession Numbers: N1998-277166

STRATOS.001A

PATENT

IN THE UNITED STATES PATENT AND TRADEMARK OFFICE

Applicant : Christensen et al.
 Appl. No. : 09/953,335
 Filed : September 13, 2001
 For : SYSTEM AND METHOD FOR
 ORDERING AND DELIVERING
 MEDIA CONTENT
 Examiner : James Kramer
 Group Art Unit : 3627

CERTIFICATE OF FAX TRANSMISSION

I hereby certify that this correspondence and all marked attachments are being transmitted via facsimile to Examiner James A. Kramer, Fax No. (703) 308-3687 of the USPTO on the date shown below:

November 25, 2003

(Date)

Perry D. Oldham
Perry D. Oldham, Reg. No. 52,082

RESPONSE TO OFFICE ACTION

Commissioner for Patents
P.O. Box 1450
Alexandria, VA 22313-1450

Dear Sir:

In response to a June 27, 2003 Office Action, Applicants respond as follows:

Amendments to the Specification begin on page 2 of this paper.

Amendments to the Claims are reflected in the listing of claims which begins on page 3 of this paper.

Remarks/Arguments begin on page 10 of this paper.

Appl. No. : 09/953,335
Filed : September 13, 2001

AMENDMENTS TO THE SPECIFICATION

Please replace the paragraph beginning at page 3, line 1 with the following amended paragraph:

A similar standard used in Europe is the European Radio Data ~~Service~~ System (RDS).

Please replace the paragraph beginning at page 6, line 29 with the following amended paragraph:

In one embodiment, a pointer to an ~~Open Application Data (OAD)~~ Open Data Applications (ODA) group is transmitted in a Type 3A group. The pointer, 16 message bits and 16 bit identifier (AID) are transmitted once a second.

Please replace the paragraph beginning at page 7, line 1 with the following amended paragraph:

In one embodiment, an ~~[[OAD]]~~ ODA group with 37 usable bits is transmitted once a second during the broadcast of a "tagged" program. The ~~[[OAD]]~~ ODA group can contain, for example, a song or commercial campaign identification.

Appl. No. : 09/953,335
Filed : September 13, 2001

AMENDMENTS TO THE CLAIMS

Claim 1 (currently amended): ~~A system for performing a transaction based on data provided as part of that~~ allows a user to perform an action responsive to program material contained in a broadcast signal, comprising:

a program material identification tagging system that obtains digital identifying information about the program material from a broadcaster and provides a unique program reference tag corresponding to the identifying information to a broadcast data encoder for broadcast and to a program history database;

a broadcast receiver circuit that extracts a RBDS broadcast data signal from a broadcast channel, said the broadcast channel comprising an audio stream and a RBDS broadcast data stream, wherein the data stream comprises the unique program reference tag that corresponds to the identifying information about the that identifies program material in the audio stream;

a display capable of displaying information corresponding to the data signal;

a user input control that allows a user to select a transaction make a selection from the displayed information; and

a first output module that provides an output signal comprising the selected program reference tag and a user reference tag, the output signal being provided to the program reference tag history database;

a first comparator that compares the user reference tag with stored user information and generates an approval signal;

a second comparator that compares the selected program reference tag with the unique program reference tag provided by the program reference tag history database and generates a verification signal; and

a second output module that generates a fulfillment signal based upon the approval signal and the verification signal.

~~an output device that provides a transaction request comprising an identity of a user and an identification of the selected transaction, said transaction request being provided to a response authentication system.~~

Appl. No. : 09/953,335
Filed : September 13, 2001

Claim 2 (original): The system as in Claim 1, wherein the displayed information identifies a media file available for purchase.

Claim 3 (currently amended): The system as in Claim 2, further comprising an input to receive the media file. ~~purchased audio.~~

Claim 4 (original): The system as in Claim 3, wherein the input is a wireless network connection.

Claim 5 (currently amended): The system as in Claim 1, wherein the first output device is module comprises a removable memory device.

Claim 6 (currently amended): The system as in Claim 1, wherein the first output device is module comprises a serial data port.

Claim 7 (currently amended): The system as in Claim 1, wherein the first output device is module comprises a parallel data port.

Claim 8 (currently amended): The system as in Claim 1, wherein the first output device is module comprises a wireless transmitter.

Claim 9 (currently amended): A system for responding to a data stream sent in combination with a media stream on a radio broadcast signal, comprising:

a broadcast receiver circuit that detects the radio broadcast signal and extracts a data signal from the data stream, at least a portion of the data signal configured to identify program content in said media stream;

memory for storing the data signal;

a display for displaying information corresponding to the data signal;

a user input control that allows a user to initiate a purchase request corresponding to the data signal;

~~a transmitter that transmits the purchase request to a response authentication system;~~

a first output module that provides an output signal comprising the identified program content and a user reference tag, the output signal being provided to a program reference tag history database;

a first comparator that compares the user reference tag with stored user information and generates an approval signal;

Appl. No. : 09/953,335
Filed : September 13, 2001

a second comparator that compares the identified program content with a program reference tag provided by the program reference tag history database and generates a verification signal;

a second output module that generates a fulfillment signal based upon the approval signal and the verification signal; and

a media download device for receiving media corresponding to said purchase request over a communications network.

Claim 10 (original): The system as in Claim 9, wherein said user input control is a button.

Claim 11 (original): The system as in Claim 9, wherein said user input control is a voice command device.

Claim 12 (original): The system as in Claim 9, wherein the data stream conforms to the Radio Broadcast Data System Standard.

Claim 13 (currently amended): The system as in Claim 9, wherein the data stream conforms to the Radio Data ~~Service~~ System Standard.

Claim 14 (currently amended): The system as in Claim 9, wherein the ~~transmitter~~ first output module uses a wireless connection.

Claim 15 (currently amended): The system as in Claim 9, wherein the ~~transmitter~~ first output module uses an interface with a computer.

Claim 16 (withdrawn): A response authentication system for processing requests sent in response to a data stream embedded within a broadcast radio signal, comprising:

a database that contains customer information;

a database that correlates a data stream identifier code with a location of the data stream on a communications network;

a server that correlates the receipt of a request for a specified data stream with information contained in the data stream location database, the request generated by user response to the broadcast radio signal having a program portion and a data portion, said data portion identifying said program portion; and

an order fulfillment server that receives communication of customer information.

Appl. No. : 09/953,335
 Filed : September 13, 2001

Claim 17 (withdrawn): The system as in Claim 16, wherein a completed order results in a download of a file corresponding to the specified data stream.

Claim 18 (withdrawn): The system of Claim 16, wherein the data stream identifier code is extracted from identification information stored on a compact disc.

Claim 19 (currently amended): A method of providing a response to a data stream embedded within a broadcast channel, comprising, in no particular order: ~~the steps of:~~

- identifying an audio stream that is to be transmitted over the broadcast channel;
- communicating the audio stream identifier information to a database;
- using the database to determine a program reference tag corresponding to the identified audio stream;
- determining a broadcast source identifier tag corresponding to a broadcast station;
- generating a data packet comprising the program reference tag, the broadcast source identifier tag and a tag that identifies the source of the database;
- broadcasting the data packet as a first modulated signal stream and the audio stream as a second modulated signal stream;
- ~~extracting a digital data signal from a radio broadcast signal that comprises a modulated digital signal stream and a modulated analog signal stream;~~
- demodulating the first modulated signal stream to extract the data packet;
- ~~demodulating the second modulated analog signal stream and playing the demodulated analog signal stream; and generating an audio signal;~~
- displaying the digital data in a format that allows a user to identify and scroll through the contents of the digital data signal; and corresponding to the data packet for viewing by a user;
- determining a user identifier tag;
- preparing, in response to user input, a response packet comprising the program reference tag, the broadcast source identifier tag, and the user identifier tag;
- ~~transmitting a selection chosen from the displayed digital data by the user;~~ the response packet to a response authentication system;
- verifying the user identifier tag; and
- acting on the response packet as directed by the verified user.

Appl. No. : 09/953,335
 Filed : September 13, 2001

Claim 20 (original): A method of receiving responses to an audio broadcast, comprising:
 broadcasting a signal comprising an audio signal and an accompanying identifying data signal, where the data signal identifies the audio signal, wherein the data signal is broadcast in a format that allows a receiver to display to a user information about the audio signal;

receiving a response from a user that identifies the user and the audio signal that the user is responding to;

verifying the user identification and the availability of the audio signal; and

acting on the user response.

Claim 21 (original): The method of Claim 20, wherein said acting on the user response comprises sending a media file.

Claim 22 (original): The method of Claim 20, wherein said acting on the user response comprises transacting a donation.

Claim 23 (original): The method of Claim 20, wherein said acting on the user response comprises sending a plurality of media files

Claim 24 (currently amended): A system for performing a transaction based on data provided as part of a broadcast signal, comprising:

a broadcast receiver circuit that extracts a data signal from a broadcast signal, said the broadcast signal comprising an audio stream, a video stream and a data stream, wherein the data stream comprises a unique program reference tag;

a display driver capable of displaying on a television screen information corresponding to the data signal;

a user input control that allows a user to ~~select a transaction~~ make a selection from the displayed information;

a first output module that provides an output signal comprising a program reference tag and a user reference tag, the output signal being provided to a program reference tag history database;

a first comparator that compares the user reference tag with stored user information and generates an approval signal;

Appl. No. : 09/953,335
Filed : September 13, 2001

a second comparator that compares the program reference tag with the unique program reference tag provided by the program reference tag history database and generates a verification signal; and

a second output module that generates a fulfillment signal based upon the approval signal and the verification signal.

~~an output device that provides a transaction request comprising an identity of a user and an identification of the selected transaction, said transaction request being provided to a response authentication system.~~

Claim 25 (currently amended): A system for performing a transaction based on data provided as part of a broadcast signal, comprising:

a broadcast receiver circuit that extracts a data signal from a broadcast radio-frequency signal, ~~said~~ the broadcast signal comprising an audio stream and a data stream;

a user input control that allows a user to initiate a transaction based on the audio stream content;

a first output module that provides an output signal comprising a program reference tag and a user reference tag, the output signal being provided to a program reference tag history database;

a first comparator that compares the user reference tag with stored user information and generates an approval signal;

a second comparator that compares the program reference tag with the unique program reference tag provided by the program reference tag history database and generates a verification signal; and

a second output module that generates a fulfillment signal based upon the approval signal and the verification signal.

~~an output device that provides a transaction request comprising an identity of a user and an identification of the selected transaction, said transaction request being provided to a response authentication system.~~

Appl. No. : **09/953,335**
Filed : **September 13, 2001**

Claim 26 (currently amended): A system for performing a transaction based on data provided as part of a broadcast radio-frequency signal, comprising:

a means for ~~extracting~~ receiving a data signal from a broadcast channel, said broadcast channel comprising an audio stream and a data stream that identifies program material in the audio stream;

a means for displaying information corresponding to the data signal;

a means for allowing a user to select a transaction from the displayed information;

a means for requesting a transaction, said transaction request comprising an identity of a user and an identification of the selected transaction, said transaction request being provided to a response authentication system.

Appl. No. : 09/953,335
 Filed : September 13, 2001

REMARKS

This communication is responsive to the June 27, 2003 Office Action. Claims 1-26 were previously pending in this application. Claims 1-15 and 19-26 were rejected under 35 U.S.C. § 103(a) as being unpatentable over U.S. Patent No. 5,303,393 to Noreen et al. (hereinafter "Noreen"). Claims 16-18 were withdrawn from further consideration by the examiner under 37 C.F.R. § 1.142(b) as being drawn to a non-elected invention.

Applicants would like to thank Examiner Kramer for the courtesies extended to Applicants' counsel, William B. Bunker, Applicant Kelly Christensen, and Tom Mock in a September 30, 2003 personal interview. A prototype radio was demonstrated, and amendments to Claim 1 were discussed. The Noreen patent cited in the Office Action was also discussed. Applicants would further like to thank Examiner Kramer for the courtesies extended to Applicants' counsel, William B. Bunker, in an October 29, 2003 personal interview. A demonstration of receiving a confirmation notice on a cellular telephone was shown to the examiner. Amendments to Claims 1 and 19 were discussed. The Noreen patent was also discussed. No specific agreement was reached in either interview; however, the Examiner agreed to favorably consider the proposed amendments.

As was discussed at the interview, Noreen discloses satellite broadcasting. Noreen does not render the pending claims unpatentable under 35 U.S.C. §§ 102 or 103.

Claims 1-15 and 19-26 were rejected under 35 U.S.C. § 103(a) as being unpatentable over Noreen and on assertions that several facts were well-known in the art. Applicants respectfully traverse the official notice taken by the Examiner. M.P.E.P. § 2144.03 states that "[i]n limited circumstances, it is appropriate for an examiner to take official notice of facts not in the record or to rely on 'common knowledge' in making a rejection, however, such rejections should be judiciously applied. . . . Official notice unsupported by documentary evidence should only be taken by the examiner where the facts asserted to be well-known, or to be common knowledge in the art are capable of instant and unquestionable demonstration as being well-known."

Applicants respectfully traverse that it is well known in the art to use a parallel port or serial port for connecting a broadcast receiver to a network. Applicants further respectfully traverse that media download devices to receive purchased digital content in a mobile environment are old and well known in the art. Finally, Applicants respectfully traverse that it would merely be a design choice to use the RBDS data signal in the claimed manner.

Appl. No. : 09/953,335
Filed : September 13, 2001

Please charge any additional fees, including any fees for additional extension of time, or credit overpayment to Deposit Account No. 11-1410.

Respectfully submitted,

KNOBBE, MARTENS, OLSON & BEAR, LLP

Dated: 11/25/2003

By: Perry Oldham
Perry D. Oldham
Registration No. 52,082
Attorney of Record
Customer No. 20,995
(949) 760-0404

H:\DOCS\PDO\PDO-2191.DOC
103103

PATENT

Case Docket No. STRATOS.001A

Date: November 25, 2003

Page 1

In re application of : Kelly Christensen et al.
 App. No. : 09/953,335
 Filed : September 13, 2001
 For : SYSTEM AND METHOD FOR ORDERING AND DELIVERING MEDIA CONTENT
 Examiner : James Kramer
 Art Unit : 3627

CERTIFICATE OF FAX TRANSMISSION

I hereby certify that this correspondence and all marked attachments are being transmitted via facsimile to Examiner James Kramer, Fax No. (703) 308-3687 of the USPTO on the date shown below:

November 25, 2003

(Date)

Perry D. Oldham

Perry D. Oldham, Reg. No. 52,082

COMMISSIONER FOR PATENTS
 P.O. Box 1450
 Alexandria, VA 22313-1450

Sir:

Transmitted herewith is an amendment in the above-identified application.

(X) An extension of time to respond for 2 month(s) is hereby requested.

Time Extension Fee:

- one month (\$55 small entity)
- two months (\$210 small entity)
- three months (\$475 small entity)

The fee has been calculated as shown below:

| CLAIMS AS FILED | | | | | | |
|--|----------------------------------|---|---------------------------------|---------------|------|----------------|
| | CLAIMS REMAINING AFTER AMENDMENT | | HIGHEST NO. PREVIOUSLY PAID FOR | PRESENT EXTRA | RATE | ADDITIONAL FEE |
| Total Claims | 23 | — | 26 | = 23 × | \$9 | = \$0 |
| Independent Claims | 7 | — | 8 | = 0 × | \$43 | = \$0 |
| Time Extension Fee | | | | | | \$210 |
| TOTAL ADDITIONAL FEE FOR THIS AMENDMENT | | | | | | \$210 |

Knobbe Martens Olson & Bear LLP

Intellectual Property Law

2040 Main Street
Fourteenth Floor
Irvine, CA 92614
Tel 949-760-0404
Fax 949-760-9502
www.kmob.com

FACSIMILE TRANSMITTAL SHEET

CONFIRMATION COPY WILL FOLLOW VIA:

- MAIL
- INTERNATIONAL AIRMAIL
- COURIER
- E-MAIL
- WILL NOT FOLLOW
- HAND DELIVERY
- WITH ENCLOSURES
- WITHOUT ENCLOSURES

CERTIFICATE OF FAX TRANSMISSION

I hereby certify that this correspondence and all marked attachments are being transmitted via facsimile to Technology Unit No. 3627, Fax No. (703) 308-3687 to the USPTO on the date shown below:

To: James Kramer
 FIRM: U.S. Patent & Trademark Office
 FACSIMILE No.: (703) 308-3687
 OUR REF.: STRATOS.001A
 YOUR REF.: 09/953,335
 FROM: Perry D. Oldham
 OPERATOR: Vicki McCarty No. OF PAGES: 16 (incl. cover sheet)
 DATE: November 25, 2003 TIME:

IF YOU DID NOT RECEIVE ALL OF THE PAGES PLEASE CALL BACK IMMEDIATELY
 OPERATOR PHONE No.: (949) 760-0404 FACSIMILE No.: (949) 760-9502

MESSAGE: PLEASE SEE ATTACHED RESPONSE TO THE JUNE 27, 2003 OFFICE ACTION. A HARD COPY OF THE OFFICE ACTION FOLLOW VIA U.S. MAIL.

H:\DOCS\FDO\FAXES\STRATOS PTO FAX.DOC
112503

San Diego
619-235-8550

San Francisco
415-954-4114

Los Angeles
310-551-3450

Riverside
909-781-9231

San Luis Obispo
805-547-5580

PATENT

Case Docket No. STRATOS.001A
 Date: November 25, 2003
 Page 1

In re application of : Kelly Christensen et al.
 App. No. : 09/953,335
 Filed : September 13, 2001
 For : SYSTEM AND METHOD FOR ORDERING AND DELIVERING MEDIA CONTENT
 Examiner : James Kramer
 Art Unit : 3627

CERTIFICATE OF FAX TRANSMISSION

I hereby certify that this correspondence and all marked attachments are being transmitted via facsimile to Examiner James Kramer, Fax No. (703) 308-3687 of the USPTO on the date shown below:

November 25, 2003

(Date)

Perry J. Oldham

Perry J. Oldham, Reg. No. 52,082

COMMISSIONER FOR PATENTS
 P.O. Box 1450
 Alexandria, VA 22313-1450

Sir:

Transmitted herewith is an amendment in the above-identified application.

(X) An extension of time to respond for 2 month(s) is hereby requested.

Time Extension Fee:

- one month (\$55 small entity)
- two months (\$210 small entity)
- three months (\$475 small entity)

The fee has been calculated as shown below:

| CLAIMS AS FILED | | | | | | |
|--|----------------------------------|---|---------------------------------|---------------|------|----------------|
| | CLAIMS REMAINING AFTER AMENDMENT | | HIGHEST NO. PREVIOUSLY PAID FOR | PRESENT EXTRA | RATE | ADDITIONAL FEE |
| Total Claims | 23 | — | 26 | = 23 × | \$9 | = \$0 |
| Independent Claims | 7 | — | 8 | = 0 × | \$43 | = \$0 |
| Time Extension Fee | | | | | | \$210 |
| TOTAL ADDITIONAL FEE FOR THIS AMENDMENT | | | | | | \$210 |

PATENT

Case Docket No. STRATOS.001A

Date: November 25, 2003

Page 2

-
- (X) The present application qualifies for small entity status under 37 C.F.R. § 1.27.
- (X) Information Disclosure Statement (13 References to be mailed under separate cover)
- (X) Return prepaid postcard.
- (X) Please charge our Deposit Account in the amount of \$210.
- (X) Please charge any additional fees, including any fees for additional extension of time, or credit overpayment to Deposit Account No. 11-1410.

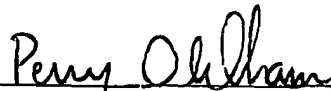

Perry D. Oldham
Registration No. 52,032
Attorney of Record
Customer No. 20,995
(949) 760-0404

H:\DOCS\PD\OV\DO-2225.DOC
112503

Knobbe Martens Olson & Bear LLP*Intellectual Property Law*

2040 Main Street
 Fourteenth Floor
 Irvine, CA 92614
 Tel 949-760-0404
 Fax 949-760-9502
 www.kmob.com

REFAX

FACSIMILE TRANSMITTAL SHEET**CONFIRMATION COPY WILL FOLLOW VIA:**

- | | |
|--|---|
| <input type="checkbox"/> MAIL | <input type="checkbox"/> WILL <u>NOT</u> FOLLOW |
| <input type="checkbox"/> INTERNATIONAL AIRMAIL | <input type="checkbox"/> HAND DELIVERY |
| <input type="checkbox"/> COURIER | <input type="checkbox"/> WITH ENCLOSURES |
| <input type="checkbox"/> E-MAIL | <input type="checkbox"/> WITHOUT ENCLOSURES |

CERTIFICATE OF FAX TRANSMISSION

I hereby certify that this correspondence and all marked attachments are being transmitted via facsimile to Technology Unit No. 3627, Fax No. (703) 308-3687 to the USPTO on the date shown below:

TO: James Kramer
 FIRM: U.S. Patent & Trademark Office
 FACSIMILE NO.: (703) 308-3687
 OUR REF.: STRATOS.001A
 YOUR REF.: 09/953,335
 FROM: Perry D. Oldham
 OPERATOR: Vicki McCarty NO. OF PAGES: 16 (incl. cover sheet)
 DATE: November 25, 2003 TIME:

IF YOU DID NOT RECEIVE ALL OF THE PAGES PLEASE CALL BACK IMMEDIATELY

OPERATOR PHONE No.: (949) 760-0404 FACSIMILE No.: (949) 760-9502

MESSAGE: PLEASE SEE ATTACHED RESPONSE TO THE JUNE 27, 2003 OFFICE ACTION. A HARD COPY OF THE OFFICE ACTION FOLLOW VIA U.S. MAIL.

H:\DOCS\PD\OFAXES\STRATOS PTO FAX.DOC
 112503

San Diego
 619-235-8550

San Francisco
 415-954-4114

Los Angeles
 310-551-3450

Riverside
 909-781-9231

San Luis Obispo
 805-547-5580

Docket No.: STRATOS.001A

Customer No. 20,995

INFORMATION DISCLOSURE STATEMENT

| | | |
|----------------|---|---|
| Applicant | : | Kelly Christensen et al. |
| App. No. | : | 09/953,335 |
| Filed | : | September 13, 2001 |
| For | : | SYSTEM AND METHOD FOR ORDERING AND DELIVERING MEDIA CONTENT |
| Examiner | : | James Kramer |
| Group Art Unit | : | 3627 |

Commissioner for Patents
P.O. Box 1450
Alexandria, VA 22313-1450

Dear Sir:

Enclosed is form PTO-1449 listing 13 references that are also enclosed.

This Information Disclosure Statement is being filed before the mailing date of a final action under 37 C.F.R. § 1.113 and before the mailing date of a Notice of Allowance under § 1.311. A certification under 37 C.F.R. § 1.97(e) is set forth below. Thus, no fee is required as set forth in 37 C.F.R. § 1.97(c).

CERTIFICATION UNDER 37 C.F.R. § 1.97(e)(1)

I hereby certify that each item of information contained in this Statement was first cited in a communication from a foreign Patent Office in a counterpart foreign application not more than three months prior to the filing of this Information Disclosure Statement.

Respectfully submitted,
KNOBBE, MARTENS, OLSON & BEAR, LLP

Dated: 11/25/2003

By: Perry D. Oldham
Perry D. Oldham
Registration No. 52,082
Attorney of Record
Customer No. 20,995
(949) 760-0404

| | | |
|--|--|-------------------------------|
| FORM PTO-1449 U.S. DEPARTMENT OF COMMERCE PATENT AND TRADEMARK OFFICE INFORMATION DISCLOSURE STATEMENT BY APPLICANT (USE SEVERAL SHEETS IF NECESSARY) | ATTY. DOCKET NO. STRATOS.001A | APPLICATION NO. 09/953,335 |
| | APPLICANT Kelly M. Christensen, et al | |
| | FILING DATE September 13, 2001 | GROUP 9827 |

| U.S. PATENT DOCUMENTS | | | | | | | |
|-----------------------|----|-----------------|---------|----------------|-------|----------|------------------------------|
| EXAMINER INITIAL | | DOCUMENT NUMBER | DATE | NAME | CLASS | SUBCLASS | FILING DATE (IF APPROPRIATE) |
| | 1. | US2003/0097338 | 5/22/03 | Manovich et al | | | |
| | | | | | | | |

| FOREIGN PATENT DOCUMENTS | | | | | | | | |
|--------------------------|----|------------------|---------|--------------------|-------|----------|-------------|----|
| EXAMINER INITIAL | | DOCUMENT NUMBER | DATE | COUNTRY | CLASS | SUBCLASS | TRANSLATION | |
| | | | | | | | YES | NO |
| | 2 | PCT/GB92/00181 | 8/20/92 | Tait et al | | | | |
| | 3 | PCT/GB93/01526 | 2/3/94 | Tait et al | | | | |
| | 4 | PCT/CA96/00794 | 6/12/97 | Michael Pocock | | | | |
| | 5 | PCT/FI97/00315 | 12/4/97 | Behruz Vazvan | | | | |
| | 6 | PCT/US00/17157 | 1/4/01 | Davis et al | | | | |
| | 7 | PCT/US01/02781 | 8/9/01 | S. Jeffrey | | | | |
| | 8 | EP 0 713 335 A2 | 5/22/96 | August et al | | | | |
| | 9 | DE 44 27 046 A1 | 2/1/96 | Goldscheider et al | | | | |
| | 10 | DE 196 27 308 A1 | 1/2/98 | Dr. Peter Mhatsch | | | | |
| | 11 | 10-135855 | 5/22/98 | Japanese Patent | | | | |

| EXAMINER INITIAL | OTHER DOCUMENTS (INCLUDING AUTHOR, TITLE, DATE, PERTINENT PAGES, ETC.) |
|------------------|---|
| | 12 "Bookmark Your World", 1999- 2000 Xenote, www.xenote.com |
| | 13 1/25/00, Showcase 2000 - Xenote Press Release re Xenote iTag, www.xenote.com/html/press/realcascs.html |
| | 14 |
| | 15 |
| | 16 |

H:\DOCS\PDO\PDO-2211.DOC
111003

| | |
|--|-----------------|
| EXAMINER | DATE CONSIDERED |
| *EXAMINER: INITIAL IF CITATION CONSIDERED, WHETHER OR NOT CITATION IS IN CONFORMANCE WITH MPEP 809; DRAW LINE THROUGH CITATION IF NOT IN CONFORMANCE AND NOT CONSIDERED, INCLUDE COPY OF THIS FORM WITH NEXT COMMUNICATION TO APPLICANT. | |

Docket No.: STRATOS.001A

Customer No. 20,995

INFORMATION DISCLOSURE STATEMENT

| | | |
|----------------|---|---|
| Applicant | : | Kelly Christensen et al. |
| App. No. | : | 09/953,335 |
| Filed | : | September 13, 2001 |
| For | : | SYSTEM AND METHOD FOR ORDERING AND DELIVERING MEDIA CONTENT |
| Examiner | : | James Kramer |
| Group Art Unit | : | 3627 |

Commissioner for Patents
P.O. Box 1450
Alexandria, VA 22313-1450

Dear Sir:

Enclosed is form PTO-1449 listing 13 references that are also enclosed.

This Information Disclosure Statement is being filed before the mailing date of a final action under 37 C.F.R. § 1.113 and before the mailing date of a Notice of Allowance under § 1.311. A certification under 37 C.F.R. § 1.97(e) is set forth below. Thus, no fee is required as set forth in 37 C.F.R. § 1.97(c).

CERTIFICATION UNDER 37 C.F.R. § 1.97(e)(1)

I hereby certify that each item of information contained in this Statement was first cited in a communication from a foreign Patent Office in a counterpart foreign application not more than three months prior to the filing of this Information Disclosure Statement.

Respectfully submitted,
KNOBBE, MARTENS, OLSON & BEAR, LLP

Dated:

11/25/2003

By:

Perry Oldham

Perry D. Oldham
Registration No. 52,082
Attorney of Record
Customer No. 20,995
(949) 760-0404

H:\DOCS\PDO\PDO-2226.DOC
112503

Appl. No. : 09/953,335
Filed : September 13, 2001

Please charge any additional fees, including any fees for additional extension of time, or credit overpayment to Deposit Account No. 11-1410.

Respectfully submitted,

KNOBBE, MARTENS, OLSON & BEAR, LLP

Dated: 11/25/2003

By: Perry D. Oldham
Perry D. Oldham
Registration No. 52,082
Attorney of Record
Customer No. 20,995
(949) 760-0404

H:\DOCS\PDO\PDO-2191.DOC
103103

| | | |
|--|--|-------------------------------|
| FORM PTO-1449 U.S. DEPARTMENT OF COMMERCE PATENT AND TRADEMARK OFFICE INFORMATION DISCLOSURE STATEMENT BY APPLICANT (USE SEVERAL SHEETS IF NECESSARY) | ATTY. DOCKET NO. STRATOS.001A | APPLICATION NO. 09/853,335 |
| | APPLICANT Kelly M. Christensen, et al | |
| | FILING DATE September 13, 2001 | GROUP 3827 |

| U.S. PATENT DOCUMENTS | | | | | | | |
|-----------------------|----|-----------------|---------|----------------|-------|----------|------------------------------|
| EXAMINER INITIAL | | DOCUMENT NUMBER | DATE | NAME | CLASS | SUBCLASS | FILING DATE (IF APPROPRIATE) |
| | 1. | US2003/0097338 | 5/22/03 | Manovich et al | | | |
| | | | | | | | |

| FOREIGN PATENT DOCUMENTS | | | | | | | | |
|--------------------------|----|------------------|---------|--------------------|-------|----------|-------------|----|
| EXAMINER INITIAL | | DOCUMENT NUMBER | DATE | COUNTRY | CLASS | SUBCLASS | TRANSLATION | |
| | | | | | | | YES | NO |
| | 2 | PCT/GB92/00181 | 8/20/92 | Tait et al | | | | |
| | 3 | PCT/GB93/01526 | 2/3/94 | Tait et al | | | | |
| | 4 | PCT/CA96/00794 | 6/12/97 | Michael Pocock | | | | |
| | 5 | PCT/FI97/00315 | 12/4/97 | Behruz Vazvan | | | | |
| | 6 | PCT/US00/17157 | 1/4/01 | Davis et al | | | | |
| | 7 | PCT/US01/02781 | 8/9/01 | S. Jeffrey | | | | |
| | 8 | EP 0 713 335 A2 | 5/22/96 | August et al | | | | |
| | 9 | DE 44 27 046 A1 | 2/1/96 | Goldschelder et al | | | | |
| | 10 | DE 196 27 308 A1 | 1/2/98 | Dr. Peter Mihatsch | | | | |
| | 11 | 10-135855 | 5/22/98 | Japanese Patent | | | | |

| EXAMINER INITIAL | OTHER DOCUMENTS (INCLUDING AUTHOR, TITLE, DATE, PERTINENT PAGES, ETC.) | |
|------------------|--|--|
| | 12 | "Bookmark Your World", 1999- 2000 Xenote, www.xenote.com |
| | 13 | 1/25/00, Showcase 2000 - Xenote Press Release re Xenote iTag, www.xenote.com/html/press/releases.html |
| | 14 | |
| | 15 | |
| | 16 | |

H:\DOCS\PDOPDO-2211.DOC
111003

| | |
|--|-----------------|
| EXAMINER | DATE CONSIDERED |
| *EXAMINER: INITIAL IF CITATION CONSIDERED, WHETHER OR NOT CITATION IS IN CONFORMANCE WITH MPEP 609; DRAW LINE THROUGH CITATION IF NOT IN CONFORMANCE AND NOT CONSIDERED. INCLUDE COPY OF THIS FORM WITH NEXT COMMUNICATION TO APPLICANT. | |

Auto-Reply Facsimile Transmission

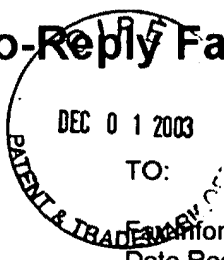

TO: [Redacted]
FAX Information
Date Received:
Total Pages:

Fax Sender at 949 760 9502

11/26/2003 12:18:43 AM [Eastern Standard Time]
17 (including cover page)

ADVISORY: This is an automatically generated return receipt confirmation of the facsimile transmission received by the Office. Please check to make sure that the number of pages listed as received in Total Pages above matches what was intended to be sent. Applicants are advised to retain this receipt in the unlikely event that proof of this facsimile transmission is necessary. Applicants are also advised to use the certificate of facsimile transmission procedures set forth in 37 CFR 1.8(a) and (b), 37 CFR 1.6(f). Trademark Applicants, also see the Trademark Manual of Examining Procedure (TMEP) section 306 et seq.

Received
Cover
Page
=====>

25/11 2003 21:15 FAX 949 760 9502 KR08 U.C. 001

Knobbe Martens Olson & Bear LLP
Intellectual Property Law

2040 Main Street
Fourteenth Floor
Irvine, CA 92614
Tel 949-760-0404
Fax 949-760-0502
www.knob.com

FACSIMILE TRANSMITTAL SHEET

CONFIRMATION COPY WILL FOLLOW VIA:

MAIL WILL NOT FOLLOW
 INTERNATIONAL AIRMAIL HAND DELIVERY
 COURIER WITH ENCLOSURES
 E-MAIL WITHOUT ENCLOSURES

Confidentiality Notice:
The documents accompanying this facsimile transmission contain confidential information which may be legally privileged. The information is intended only for the use of the recipient named below. If you have received this facsimile in error, please immediately notify us by telephone to arrange for return of the original documents to us and any disclosure, copying, distribution or the taking of any action in reliance on the contents of this facsimile information is strictly prohibited.

TO: U.S. PATENT & TRADEMARK OFFICE
FACSIMILE NO.: (703) 872-9306
OUR REF.: STRATOS.001A
APP. NO.: 09/953,335
FILING DATE: September 13, 2001
FROM: Perry D. Oldham
OPERATOR: Perry D. Oldham NO. OF PAGES: 17 (incl. cover sheet)
DATE: November 25, 2003 TIME:

IF YOU DID NOT RECEIVE ALL OF THE PAGES PLEASE CALL BACK IMMEDIATELY
OPERATOR PHONE NO.: (949) 760-0404 FACSIMILE NO.: (949) 760-9502

MESSAGE: OFFICE ACTION RESPONSE

PERRY D. OLDHAM
(949) 721-2961

REDUCED-RATE FAX DOC
112500

San Diego 619-233-6550 San Francisco 415-436-4114 Los Angeles 310-351-3450 Riverside 909-781-9251 San Luis Obispo 805-547-6580

PAGE 107 REV'D AT 11/25/2003 12:18:43 AM [Eastern Standard Time] BY: STRATOS-001A-H* 2003-12-26 12:18:43 AM FAX 949 760 9502 DURATION: 00:01:21.11

STRATOS.001A

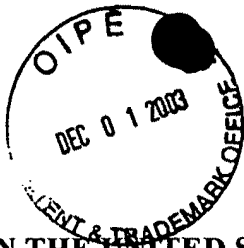

PATENT

[Handwritten signatures]

IN THE UNITED STATES PATENT AND TRADEMARK OFFICE

Applicant : Christensen et al.
 Appl. No. : 09/953,335
 Filed : September 13, 2001
 For : SYSTEM AND METHOD FOR ORDERING AND DELIVERING MEDIA CONTENT
 Examiner : James Kramer
 Group Art Unit : 3627

CERTIFICATE OF FAX TRANSMISSION

I hereby certify that this correspondence and all marked attachments are being transmitted via facsimile to Examiner James A. Kramer, Fax No. (703) 308-3687 of the USPTO on the date shown below:

November 25, 2003

(Date)

Perry D. Oldham
Perry D. Oldham, Reg. No. 52,082

RESPONSE TO OFFICE ACTION

RECEIVED

DEC 08 2003

GROUP 3600

Commissioner for Patents
P.O. Box 1450
Alexandria, VA 22313-1450

Dear Sir:

In response to a June 27, 2003 Office Action, Applicants respond as follows:

Amendments to the Specification begin on page 2 of this paper.

Amendments to the Claims are reflected in the listing of claims which begins on page 3 of this paper.

Remarks/Arguments begin on page 10 of this paper.

Appl. No. : 09/953,335
Filed : September 13, 2001

AMENDMENTS TO THE SPECIFICATION

Please replace the paragraph beginning at page 3, line 1 with the following amended paragraph:

A similar standard used in Europe is the European Radio Data ~~Service~~
System (RDS).

Please replace the paragraph beginning at page 6, line 29 with the following amended paragraph:

In one embodiment, a pointer to an ~~Open Application Data (OAD)~~ Open Data Applications (ODA) group is transmitted in a Type 3A group. The pointer, 16 message bits and 16 bit identifier (AID) are transmitted once a second.

Please replace the paragraph beginning at page 7, line 1 with the following amended paragraph:

In one embodiment, an ~~[[OAD]]~~ ODA group with 37 usable bits is transmitted once a second during the broadcast of a "tagged" program. The ~~[[OAD]]~~ ODA group can contain, for example, a song or commercial campaign identification.

Appl. No. : 09/953,335
Filed : September 13, 2001

AMENDMENTS TO THE CLAIMS

Claim 1 (currently amended): ~~A system for performing a transaction based on data provided as part of~~ that allows a user to perform an action responsive to program material contained in a broadcast signal, comprising:

a program material identification tagging system that obtains digital identifying information about the program material from a broadcaster and provides a unique program reference tag corresponding to the identifying information to a broadcast data encoder for broadcast and to a program history database;

a broadcast receiver circuit that extracts a RBDS broadcast data signal from a broadcast channel, said the broadcast channel comprising an audio stream and a RBDS broadcast data stream, wherein the data stream comprises the unique program reference tag that corresponds to the identifying information about the that identifies program material in the audio stream;

a display capable of displaying information corresponding to the data signal;

a user input control that allows a user to select a transaction make a selection from the displayed information; and

a first output module that provides an output signal comprising the selected program reference tag and a user reference tag, the output signal being provided to the program reference tag history database;

a first comparator that compares the user reference tag with stored user information and generates an approval signal;

a second comparator that compares the selected program reference tag with the unique program reference tag provided by the program reference tag history database and generates a verification signal; and

a second output module that generates a fulfillment signal based upon the approval signal and the verification signal.

~~an output device that provides a transaction request comprising an identity of a user and an identification of the selected transaction, said transaction request being provided to a response authentication system.~~

Appl. No. : 09/953,335
Filed : September 13, 2001

Claim 2 (original): The system as in Claim 1, wherein the displayed information identifies a media file available for purchase.

Claim 3 (currently amended): The system as in Claim 2, further comprising an input to receive the media file. ~~purchased audio.~~

Claim 4 (original): The system as in Claim 3, wherein the input is a wireless network connection.

Claim 5 (currently amended): The system as in Claim 1, wherein the first output device is module comprises a removable memory device.

Claim 6 (currently amended): The system as in Claim 1, wherein the first output device is module comprises a serial data port.

Claim 7 (currently amended): The system as in Claim 1, wherein the first output device is module comprises a parallel data port.

Claim 8 (currently amended): The system as in Claim 1, wherein the first output device is module comprises a wireless transmitter.

Claim 9 (currently amended): A system for responding to a data stream sent in combination with a media stream on a radio broadcast signal, comprising:

a broadcast receiver circuit that detects the radio broadcast signal and extracts a data signal from the data stream, at least a portion of the data signal configured to identify program content in said media stream;

memory for storing the data signal;

a display for displaying information corresponding to the data signal;

a user input control that allows a user to initiate a purchase request corresponding to the data signal;

~~a transmitter that transmits the purchase request to a response authentication system;~~

a first output module that provides an output signal comprising the identified program content and a user reference tag, the output signal being provided to a program reference tag history database;

a first comparator that compares the user reference tag with stored user information and generates an approval signal;

Appl. No. : 09/953,335
Filed : September 13, 2001

a second comparator that compares the identified program content with a program reference tag provided by the program reference tag history database and generates a verification signal;

a second output module that generates a fulfillment signal based upon the approval signal and the verification signal; and

a media download device for receiving media corresponding to said purchase request over a communications network.

Claim 10 (original): The system as in Claim 9, wherein said user input control is a button.

Claim 11 (original): The system as in Claim 9, wherein said user input control is a voice command device.

Claim 12 (original): The system as in Claim 9, wherein the data stream conforms to the Radio Broadcast Data System Standard.

Claim 13 (currently amended): The system as in Claim 9, wherein the data stream conforms to the Radio Data ~~Service~~ System Standard.

Claim 14 (currently amended): The system as in Claim 9, wherein the ~~transmitter~~ first output module uses a wireless connection.

Claim 15 (currently amended): The system as in Claim 9, wherein the ~~transmitter~~ first output module uses an interface with a computer.

Claim 16 (withdrawn): A response authentication system for processing requests sent in response to a data stream embedded within a broadcast radio signal, comprising:

a database that contains customer information;

a database that correlates a data stream identifier code with a location of the data stream on a communications network;

a server that correlates the receipt of a request for a specified data stream with information contained in the data stream location database, the request generated by user response to the broadcast radio signal having a program portion and a data portion, said data portion identifying said program portion; and

an order fulfillment server that receives communication of customer information.

Appl. No. : 09/953,335
Filed : September 13, 2001

Claim 17 (withdrawn): The system as in Claim 16, wherein a completed order results in a download of a file corresponding to the specified data stream.

Claim 18 (withdrawn): The system of Claim 16, wherein the data stream identifier code is extracted from identification information stored on a compact disc.

Claim 19 (currently amended): A method of providing a response to a data stream embedded within a broadcast channel, comprising, in no particular order: the steps of:

identifying an audio stream that is to be transmitted over the broadcast channel;

communicating the audio stream identifier information to a database;

using the database to determine a program reference tag corresponding to the identified audio stream;

determining a broadcast source identifier tag corresponding to a broadcast station;

generating a data packet comprising the program reference tag, the broadcast source identifier tag and a tag that identifies the source of the database;

broadcasting the data packet as a first modulated signal stream and the audio stream as a second modulated signal stream;

~~extracting a digital data signal from a radio broadcast signal that comprises a modulated digital signal stream and a modulated analog signal stream;~~

demodulating the first modulated signal stream to extract the data packet;

~~demodulating the second modulated analog signal stream and playing the demodulated analog signal stream; and generating an audio signal;~~

~~displaying the digital data in a format that allows a user to identify and scroll through the contents of the digital data signal; and corresponding to the data packet for viewing by a user;~~

determining a user identifier tag;

preparing, in response to user input, a response packet comprising the program reference tag, the broadcast source identifier tag, and the user identifier tag;

~~transmitting a selection chosen from the displayed digital data by the user. the response packet to a response authentication system;~~

verifying the user identifier tag; and

acting on the response packet as directed by the verified user.

Appl. No. : 09/953,335
Filed : September 13, 2001

Claim 20 (original): A method of receiving responses to an audio broadcast, comprising:
broadcasting a signal comprising an audio signal and an accompanying identifying data signal, where the data signal identifies the audio signal, wherein the data signal is broadcast in a format that allows a receiver to display to a user information about the audio signal;

receiving a response from a user that identifies the user and the audio signal that the user is responding to;

verifying the user identification and the availability of the audio signal; and

acting on the user response.

Claim 21 (original): The method of Claim 20, wherein said acting on the user response comprises sending a media file.

Claim 22 (original): The method of Claim 20, wherein said acting on the user response comprises transacting a donation.

Claim 23 (original): The method of Claim 20, wherein said acting on the user response comprises sending a plurality of media files

Claim 24 (currently amended): A system for performing a transaction based on data provided as part of a broadcast signal, comprising:

a broadcast receiver circuit that extracts a data signal from a broadcast signal, said the broadcast signal comprising an audio stream, a video stream and a data stream, wherein the data stream comprises a unique program reference tag;

a display driver capable of displaying on a television screen information corresponding to the data signal;

a user input control that allows a user to ~~select a transaction~~ make a selection from the displayed information;

a first output module that provides an output signal comprising a program reference tag and a user reference tag, the output signal being provided to a program reference tag history database;

a first comparator that compares the user reference tag with stored user information and generates an approval signal;

Appl. No. : 09/953,335
Filed : September 13, 2001

a second comparator that compares the program reference tag with the unique program reference tag provided by the program reference tag history database and generates a verification signal; and

a second output module that generates a fulfillment signal based upon the approval signal and the verification signal.

~~an output device that provides a transaction request comprising an identity of a user and an identification of the selected transaction, said transaction request being provided to a response authentication system.~~

Claim 25 (currently amended): A system for performing a transaction based on data provided as part of a broadcast signal, comprising:

a broadcast receiver circuit that extracts a data signal from a broadcast radio-frequency signal, ~~said~~ the broadcast signal comprising an audio stream and a data stream;

a user input control that allows a user to initiate a transaction based on the audio stream content;

a first output module that provides an output signal comprising a program reference tag and a user reference tag, the output signal being provided to a program reference tag history database;

a first comparator that compares the user reference tag with stored user information and generates an approval signal;

a second comparator that compares the program reference tag with the unique program reference tag provided by the program reference tag history database and generates a verification signal; and

a second output module that generates a fulfillment signal based upon the approval signal and the verification signal.

~~an output device that provides a transaction request comprising an identity of a user and an identification of the selected transaction, said transaction request being provided to a response authentication system.~~

Appl. No. : 09/953,335
Filed : September 13, 2001

Claim 26 (currently amended): A system for performing a transaction based on data provided as part of a broadcast radio-frequency signal, comprising:

a means for ~~extracting~~ receiving a data signal from a broadcast channel, said broadcast channel comprising an audio stream and a data stream that identifies program material in the audio stream;

a means for displaying information corresponding to the data signal;

a means for allowing a user to select a transaction from the displayed information;

a means for requesting a transaction, said transaction request comprising an identity of a user and an identification of the selected transaction, said transaction request being provided to a response authentication system.

Appl. No. : 09/953,335
Filed : September 13, 2001

REMARKS

This communication is responsive to the June 27, 2003 Office Action. Claims 1-26 were previously pending in this application. Claims 1-15 and 19-26 were rejected under 35 U.S.C. § 103(a) as being unpatentable over U.S. Patent No. 5,303,393 to Noreen et al. (hereinafter "Noreen"). Claims 16-18 were withdrawn from further consideration by the examiner under 37 C.F.R. § 1.142(b) as being drawn to a non-elected invention.

Applicants would like to thank Examiner Kramer for the courtesies extended to Applicants' counsel, William B. Bunker, Applicant Kelly Christensen, and Tom Mock in a September 30, 2003 personal interview. A prototype radio was demonstrated, and amendments to Claim 1 were discussed. The Noreen patent cited in the Office Action was also discussed. Applicants would further like to thank Examiner Kramer for the courtesies extended to Applicants' counsel, William B. Bunker, in an October 29, 2003 personal interview. A demonstration of receiving a confirmation notice on a cellular telephone was shown to the examiner. Amendments to Claims 1 and 19 were discussed. The Noreen patent was also discussed. No specific agreement was reached in either interview; however, the Examiner agreed to favorably consider the proposed amendments.

As was discussed at the interview, Noreen discloses satellite broadcasting. Noreen does not render the pending claims unpatentable under 35 U.S.C. §§ 102 or 103.

Claims 1-15 and 19-26 were rejected under 35 U.S.C. § 103(a) as being unpatentable over Noreen and on assertions that several facts were well-known in the art. Applicants respectfully traverse the official notice taken by the Examiner. M.P.E.P. § 2144.03 states that "[i]n limited circumstances, it is appropriate for an examiner to take official notice of facts not in the record or to rely on 'common knowledge' in making a rejection, however, such rejections should be judiciously applied. . . . Official notice unsupported by documentary evidence should only be taken by the examiner where the facts asserted to be well-known, or to be common knowledge in the art are capable of instant and unquestionable demonstration as being well-known."

Applicants respectfully traverse that it is well known in the art to use a parallel port or serial port for connecting a broadcast receiver to a network. Applicants further respectfully traverse that media download devices to receive purchased digital content in a mobile environment are old and well known in the art. Finally, Applicants respectfully traverse that it would merely be a design choice to use the RBDS data signal in the claimed manner.

Appl. No. : 09/953,335
Filed : September 13, 2001

Applicants respectfully traverse the grouping of Claims 1-15 and 19-26 to make the rejection. *See, e.g.*, M.P.E.P. § 707.07(d) (“A plurality of claims should never be grouped together in a common rejection, unless that rejection is equally applicable to all claims in the group”). Further, the rejections fail to address each of the limitations recited in the claims.

In an attempt to further the prosecution, Applicants hereby amend Claims 1, 3, 5-9, 13-15, 19, and 24-26. Claims 1-15 and 19-26 are pending and presented for further consideration. Reconsideration of the application, as amended, is therefore respectfully requested.

Submitted concurrently herewith is a Supplemental Information Disclosure Statement and form PTO-1449 citing 13 new references that recently came to Applicants’ attention. Applicant respectfully requests the Examiner to consider these references in connection with the pending claims. Copies of the references will be sent under separate cover.

CONCLUSION

Applicants have endeavored to address all of the Examiner’s concerns as expressed in the outstanding Office Action. In light of the above remarks, reconsideration and withdrawal of the outstanding rejections is specifically requested.

In view of the foregoing amendments and remarks, Applicants submit that the claims are patentably distinct from the cited art, and request that the application be allowed.

Applicants respectfully submit that the claims are in condition for allowance. Furthermore, any remarks in support of patentability of one claim should not be imputed to any other claim, even if similar terminology is used. Any remarks referring to only a portion of a claim should not be understood to base patentability on that portion; rather, patentability must rest on each claim taken as a whole. Applicant respectfully traverses each of the Examiner’s rejections and each of the Examiner’s assertions regarding what the prior art shows or teaches, even if not expressly discussed herein. Although changes to the claims have been made, no acquiescence or estoppel is or should be implied thereby; such amendments are made only to expedite prosecution of the present application and are without prejudice to the presentation or assertion, in the future, of claims relating to the same or similar subject matter.

If the Examiner finds any remaining impediment to the prompt allowance of these claims that could be clarified with a telephone conference, the Examiner is respectfully requested to initiate the same with the undersigned attorney of record at his direct dial number of (949) 721-2961.

Appl. No. : 09/953,335
Filed : September 13, 2001

Please charge any additional fees, including any fees for additional extension of time, or credit overpayment to Deposit Account No. 11-1410.

Respectfully submitted,

KNOBBE, MARTENS, OLSON & BEAR, LLP

Dated: 11/25/2003

By: Perry D. Oldham

Perry D. Oldham
Registration No. 52,082
Attorney of Record
Customer No. 20,995
(949) 760-0404

H:\DOCS\PDO\PDO-2191.DOC
103103



3627
PATENT #

Case Docket No. STRATOS.001A
Date: November 25, 2003
Page 1

In re application of : Kelly Christensen et al.
App. No. : 09/953,335
Filed : September 13, 2001
For : SYSTEM AND METHOD FOR ORDERING AND DELIVERING MEDIA CONTENT
Examiner : James Kramer
Art Unit : 3627

CERTIFICATE OF FAX TRANSMISSION

I hereby certify that this correspondence and all marked attachments are being transmitted via facsimile to Examiner James Kramer, Fax No. (703) 308-3687 of the USPTO on the date shown below:

November 25, 2003

(Date)

Perry Oldham

Perry D. Oldham, Reg. No. 52,082

COMMISSIONER FOR PATENTS
P.O. Box 1450
Alexandria, VA 22313-1450

Sir:

Transmitted herewith is an amendment in the above-identified application.

(X) An extension of time to respond for 2 month(s) is hereby requested.

Time Extension Fee:

- one month (\$55 small entity)
- two months (\$210 small entity)
- three months (\$475 small entity)

The fee has been calculated as shown below:

| CLAIMS AS FILED | | | | | | |
|--|----------------------------------|---|---------------------------------|---------------|------|----------------|
| | CLAIMS REMAINING AFTER AMENDMENT | | HIGHEST NO. PREVIOUSLY PAID FOR | PRESENT EXTRA | RATE | ADDITIONAL FEE |
| Total Claims | 23 | — | 26 | = 23 × | \$9 | = \$0 |
| Independent Claims | | — | 8 | = 0 × | \$43 | = \$0 |
| Time Extension Fee | | | | | | \$210 |
| TOTAL ADDITIONAL FEE FOR THIS AMENDMENT | | | | | | \$210 |

RECEIVED
DEC 09 2003
GROUP 3600

12/04/2003 HDANTE1 00000057 111410 09953335

01 FC:2233 210.00 DA

-
- (X) The present application qualifies for small entity status under 37 C.F.R. § 1.27.
 - (X) Information Disclosure Statement (13 References to be mailed under separate cover)
 - (X) Return prepaid postcard.
 - (X) Please charge our Deposit Account in the amount of \$210.
 - (X) Please charge any additional fees, including any fees for additional extension of time, or credit overpayment to Deposit Account No. 11-1410.

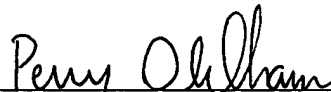

Perry D. Oldham
Registration No. 52,082
Attorney of Record
Customer No. 20,995
(949) 760-0404

H:\DGCSPDO\PDO-2225.DOC
112503



INFORMATION DISCLOSURE STATEMENT

Applicant : Kelly Christensen et al.
 App. No. : 09/953,335
 Filed : September 13, 2001
 For : SYSTEM AND METHOD FOR ORDERING AND DELIVERING MEDIA CONTENT
 Examiner : James Kramer
 Group Art Unit : 3627

RECEIVED
DEC 09 2003

GROUP 3600

Commissioner for Patents
P.O. Box 1450
Alexandria, VA 22313-1450

Dear Sir:

Enclosed is form PTO-1449 listing 13 references that are also enclosed.

This Information Disclosure Statement is being filed before the mailing date of a final action under 37 C.F.R. § 1.113 and before the mailing date of a Notice of Allowance under § 1.311. A certification under 37 C.F.R. § 1.97(e) is set forth below. Thus, no fee is required as set forth in 37 C.F.R. § 1.97(c).

CERTIFICATION UNDER 37 C.F.R. § 1.97(e)(1)

I hereby certify that each item of information contained in this Statement was first cited in a communication from a foreign Patent Office in a counterpart foreign application not more than three months prior to the filing of this Information Disclosure Statement.

Respectfully submitted,
KNOBBE, MARTENS, OLSON & BEAR, LLP

Dated: 11/25/2003

By: Perry Oldham
Perry D. Oldham
Registration No. 52,082
Attorney of Record
Customer No. 20,995
(949) 760-0404

| | | |
|---|----------------------------------|-------------------------------|
| FORM PTO-1449 U.S. DEPARTMENT OF COMMERCE PATENT AND TRADEMARK OFFICE | ATTY. DOCKET NO. STRATOS.001A | APPLICATION NO. 09/953,335 |
| INFORMATION DISCLOSURE STATEMENT BY APPLICANT | | |
| APPLICANT Kelly M. Christensen, et al | | |
| FILING DATE September 13, 2001 | | GROUP 3627 |

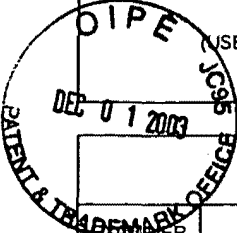

(USE SEVERAL SHEETS IF NECESSARY)

| U.S. PATENT DOCUMENTS | | | | | | |
|-----------------------|-----------------|----------------|---------|----------------|----------|------------------------------|
| EXAMINER INITIAL | DOCUMENT NUMBER | DATE | NAME | CLASS | SUBCLASS | FILING DATE (IF APPROPRIATE) |
| | 1. | US2003/0097338 | 5/22/03 | Manovich et al | | |

| FOREIGN PATENT DOCUMENTS | | | | | | | | |
|--------------------------|------------------|---------|--------------------|-------|----------|-------------|----|--|
| EXAMINER INITIAL | DOCUMENT NUMBER | DATE | COUNTRY | CLASS | SUBCLASS | TRANSLATION | | |
| | | | | | | YES | NO | |
| 2 | PCT/GB92/00181 | 8/20/92 | Tait et al | | | | | |
| 3 | PCT/GB93/01526 | 2/3/94 | Tait et al | | | | | |
| 4 | PCT/CA96/00794 | 6/12/97 | Michael Pocock | | | | | |
| 5 | PCT/FI97/00315 | 12/4/97 | Behruz Vazvan | | | | | |
| 6 | PCT/US00/17157 | 1/4/01 | Davis et al | | | | | |
| 7 | PCT/US01/02781 | 8/9/01 | S. Jeffrey | | | | | |
| 8 | EP 0 713 335 A2 | 5/22/96 | August et al | | | | | |
| 9 | DE 44 27 046 A1 | 2/1/96 | Goldscheider et al | | | | | |
| 10 | DE 196 27 308 A1 | 1/2/98 | Dr. Peter Mihatsch | | | | | |
| 11 | 10-135855 | 5/22/98 | Japanese Patent | | | | | |

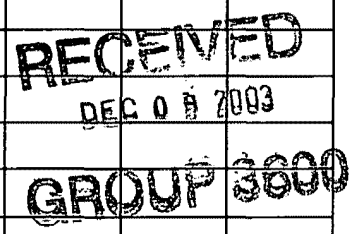

| EXAMINER INITIAL | OTHER DOCUMENTS (INCLUDING AUTHOR, TITLE, DATE, PERTINENT PAGES, ETC.) |
|------------------|--|
| 12 | "Bookmark Your World", 1999- 2000 Xenote, www.xenote.com |
| 13 | 1/25/00, Showcase 2000 - Xenote Press Release re Xenote iTag, www.xenote.com/html/press/releases.html |
| 14 | |
| 15 | |
| 16 | |

H:\DOCS\PDO\PDO-2211.DOC
111003

| | |
|--|-----------------|
| EXAMINER | DATE CONSIDERED |
| *EXAMINER: INITIAL IF CITATION CONSIDERED, WHETHER OR NOT CITATION IS IN CONFORMANCE WITH MPEP 609; DRAW LINE THROUGH CITATION IF NOT IN CONFORMANCE AND NOT CONSIDERED, INCLUDE COPY OF THIS FORM WITH NEXT COMMUNICATION TO APPLICANT. | |

| L Number | Hits | Search Text | DB | Time stamp |
|----------|------|--|-------|------------------|
| 1 | 17 | (725/75).CCLS. | USPAT | 2004/02/02 11:47 |
| 2 | 17 | (725/75).CCLS. | USPAT | 2004/02/02 11:51 |
| 3 | 87 | (725/91).CCLS. | USPAT | 2004/02/02 12:52 |
| 4 | 20 | ("4305131" "4931950" "5053956" "5111409" "5231566" "5307456" "5309355" "5319455" "5345549" "5353391" "5367621" "5388993" "5404316" "5414808" "5440678" "5451998" "5485611" "5515490" "5539450" "5583560").PN. | USPAT | 2004/02/02 12:31 |
| 5 | 72 | ("3889050" "4032972" "4077006" "4081831" "4245245" "4247106" "4253114" "4264924" "4290142" "4367557" "4450477" "4454538" "4466017" "4471380" "4491983" "4506387" "4507680" "4509073" "4523228" "4533948" "4536791" "4538174" "4567517" "4573072" "4591906" "4602279" "4616263" "4627105" "4633462" "4695880" "4706121" "4709418" "4710971" "4748689" "4760442" "4769833" "4769838" "4801190" "4821102" "4823386" "4827253" "4829372" "4847700" "4860379" "4891694" "4901367" "4903126" "4912760" "4918516" "4922532" "4941040" "4947244" "4963995" "4975771" "4994909" "4995078" "5008934" "5014125" "5027400" "5057917" "5060262" "5093718" "5109414" "5119188" "5130792" "5132992" "5133079" "5172413" "5191410" "5231494" "5253341" "5355162").PN. | USPAT | 2004/02/02 12:40 |
| 6 | 94 | (455/3.06).CCLS. | USPAT | 2004/02/02 14:59 |
| 7 | 4 | ("5635980" "6172673" "6175861" "6424646").PN. | USPAT | 2004/02/02 13:46 |
| 8 | 54 | "5063610" | USPAT | 2004/02/02 14:59 |
| 9 | 1 | ("5063610").PN. | USPAT | 2004/02/02 14:59 |
| 10 | 52 | 5063610.URPN. | USPAT | 2004/02/02 15:10 |

| L Number | Hits | Search Text | DB | Time stamp |
|----------|------|--|-------|------------------|
| 1 | 70 | (725/112).CCLS. | USPAT | 2004/02/06 11:09 |
| 4 | 4 | ("5438355" "5570295" "5640193" "5761602").PN. | USPAT | 2004/02/06 11:41 |
| 5 | 18 | ("4071697" "4451701" "4567512" "4603232" "4646145" "4734858" "4745468" "4752954" "4876592" "4893248" "4926255" "5014125" "5128752" "5142690" "5155591" "5223923" "5287181" "5382970").PN. | USPAT | 2004/02/06 11:46 |
| 6 | 54 | 5438355.URPN. | USPAT | 2004/02/06 11:49 |



UNITED STATES PATENT AND TRADEMARK OFFICE

UNITED STATES DEPARTMENT OF COMMERCE
United States Patent and Trademark Office
Address: COMMISSIONER FOR PATENTS
P.O. Box 1450
Alexandria, Virginia 22313-1450
www.uspto.gov

| APPLICATION NO. | FILING DATE | FIRST NAMED INVENTOR | ATTORNEY DOCKET NO. | CONFIRMATION NO. |
|-----------------|-------------|----------------------|---------------------|------------------|
| 09/953,335 | 09/13/2001 | Kelly M. Christensen | STRATOS.001A | 4917 |

20995 7590 02/12/2004

KNOBBE MARTENS OLSON & BEAR LLP
2040 MAIN STREET
FOURTEENTH FLOOR
IRVINE, CA 92614

EXAMINER

KRAMER, JAMES A

ART UNIT PAPER NUMBER

3627

DATE MAILED: 02/12/2004

Please find below and/or attached an Office communication concerning this application or proceeding.

Office Action Summary

| | |
|--------------------------------------|---|
| Application No. 09/953,335 | Applicant(s) CHRISTENSEN ET AL. |
| Examiner James A. Kramer | Art Unit 3627 |

-- The MAILING DATE of this communication appears on the cover sheet with the correspondence address --

Period for Reply

A SHORTENED STATUTORY PERIOD FOR REPLY IS SET TO EXPIRE 3 MONTH(S) FROM THE MAILING DATE OF THIS COMMUNICATION.

- Extensions of time may be available under the provisions of 37 CFR 1.136(a). In no event, however, may a reply be timely filed after SIX (6) MONTHS from the mailing date of this communication.
- If the period for reply specified above is less than thirty (30) days, a reply within the statutory minimum of thirty (30) days will be considered timely.
- If NO period for reply is specified above, the maximum statutory period will apply and will expire SIX (6) MONTHS from the mailing date of this communication.
- Failure to reply within the set or extended period for reply will, by statute, cause the application to become ABANDONED (35 U.S.C. § 133). Any reply received by the Office later than three months after the mailing date of this communication, even if timely filed, may reduce any earned patent term adjustment. See 37 CFR 1.704(b).

Status

- 1) Responsive to communication(s) filed on ____.
- 2a) This action is FINAL.
- 2b) This action is non-final.
- 3) Since this application is in condition for allowance except for formal matters, prosecution as to the merits is closed in accordance with the practice under *Ex parte Quayle*, 1935 C.D. 11, 453 O.G. 213.

Disposition of Claims

- 4) Claim(s) 1-26 is/are pending in the application.
4a) Of the above claim(s) 16-18 is/are withdrawn from consideration.
- 5) Claim(s) ____ is/are allowed.
- 6) Claim(s) 1-15 and 19-26 is/are rejected.
- 7) Claim(s) ____ is/are objected to.
- 8) Claim(s) ____ are subject to restriction and/or election requirement.

Application Papers

- 9) The specification is objected to by the Examiner.
- 10) The drawing(s) filed on ____ is/are: a) accepted or b) objected to by the Examiner.
Applicant may not request that any objection to the drawing(s) be held in abeyance. See 37 CFR 1.85(a).
Replacement drawing sheet(s) including the correction is required if the drawing(s) is objected to. See 37 CFR 1.121(d).
- 11) The oath or declaration is objected to by the Examiner. Note the attached Office Action or form PTO-152.

Priority under 35 U.S.C. § 119

- 12) Acknowledgment is made of a claim for foreign priority under 35 U.S.C. § 119(a)-(d) or (f).
a) All b) Some * c) None of:
1. Certified copies of the priority documents have been received.
2. Certified copies of the priority documents have been received in Application No. ____.
3. Copies of the certified copies of the priority documents have been received in this National Stage application from the International Bureau (PCT Rule 17.2(a)).
* See the attached detailed Office action for a list of the certified copies not received.

Attachment(s)

- 1) Notice of References Cited (PTO-892)
- 2) Notice of Draftsperson's Patent Drawing Review (PTO-948)
- 3) Information Disclosure Statement(s) (PTO-1449 or PTO/SB/08)
Paper No(s)/Mail Date ____.
- 4) Interview Summary (PTO-413)
Paper No(s)/Mail Date. ____.
- 5) Notice of Informal Patent Application (PTO-152)
- 6) Other: ____.

DETAILED ACTION

Claim Rejections - 35 USC § 102

(b) the invention was patented or described in a printed publication in this or a foreign country or in public use or on sale in this country, more than one year prior to the date of application for patent in the United States.

Claims 1-11, 14-15 and 19-24 are rejected under 35 U.S.C. 102(b) as being anticipated by Palmer.

Palmer teaches an interactive system for processing viewer responses to television programming. The interactive system of the invention comprises a central exchange where a database is stored (i.e. program history database). This database contains a plurality program identification codes (PIC codes) in the form of data uniquely identifying each program or portions of programs broadcasted to television receivers by a broadcaster (unique program reference tag corresponding to digital identifying information about program material) (column 1; lines 42-45 and column 3; lines 5-12).

Palmer teaches that the PIC codes are transmitted in conjunction with the TV signals (column 3; lines 19-31). Examiner notes that in order for the PIC codes to be transmitted in conjunction with the TV signals, the system of Palmer must, inherently include a broadcast data encoder.

Palmer further teaches a user console with a code reader which is cable of reading the codes embedded in the TV signal (column 3; lines 44-45). Examiner notes that the code reader corresponds to Applicant's broadcast receiver. In addition, Examiner notes that the TV signal embedded with PIC codes of Palmer corresponds to a broadcast channel comprising audio stream and a broadcast data stream, wherein the data stream comprises the unique program reference tag (PIC codes).

Art Unit: 3627

Palmer further teaches connected to each coder reader is a keypad and Liquid Crystal Display (column 3; lines 51-52). When a user views a program or commercial for a product or service of interest, he or she presses the appropriate response button to generate a viewer response signal. The system then establishes a communications link with the central exchange and transmits PIC codes together with console identification codes (CIC codes) and user encoded data to the computer of the central exchange (column 3; line 63 – column 4; line 9). (display, user input and first output module).

Palmer then teaches, on the basis of the received PIC and CIC codes, computer searches database to locate matching PIC and CIC codes (first and second comparator) (column 4; lines 10-14 and column 2; lines 61-67). After verifying the PIC and CIC codes the system retrieves from the database, specific program data associated with the PIC code and specific user data associated with the CIC code. Using the received console (user) data the retrieved program data is sent to the responding viewer (column 2; lines 1-6). Examiner notes this corresponds to second output module that generates a fulfillment signal.

Claim Rejections - 35 USC § 103

The following is a quotation of 35 U.S.C. 103(a) which forms the basis for all obviousness rejections set forth in this Office action:

(a) A patent may not be obtained though the invention is not identically disclosed or described as set forth in section 102 of this title, if the differences between the subject matter sought to be patented and the prior art are such that the subject matter as a whole would have been obvious at the time the invention was made to a person having ordinary skill in the art to which said subject matter pertains. Patentability shall not be negated by the manner in which the invention was made.

Claims 12-13 and 25 are rejected under 35 U.S.C. 103(a) as being unpatentable over

Palmer in view of Official Notice.

Art Unit: 3627

Palmer as described above does not teach the data stream conforming to the Radio Broadcast Data System Standard. Examiner takes Official Notice that the RBDS is an old and well known sub carrier for radio broadcasts and which provides a means for transmitting data signals along with a radio broadcast.

It would have been obvious to a person of ordinary skill in the art at the time the invention was made to modify the system of Palmer by transmitting the PIC Codes using the RBDS standard along with a radio broadcast in order to reach radio listeners as well as TV viewers.

Conclusion

Applicant's amendment necessitated the new ground(s) of rejection presented in this Office action. Accordingly, **THIS ACTION IS MADE FINAL**. See MPEP § 706.07(a). Applicant is reminded of the extension of time policy as set forth in 37 CFR 1.136(a).

A shortened statutory period for reply to this final action is set to expire **THREE MONTHS** from the mailing date of this action. In the event a first reply is filed within **TWO MONTHS** of the mailing date of this final action and the advisory action is not mailed until after the end of the **THREE-MONTH** shortened statutory period, then the shortened statutory period will expire on the date the advisory action is mailed, and any extension fee pursuant to 37 CFR 1.136(a) will be calculated from the mailing date of the advisory action. In no event, however, will the statutory period for reply expire later than **SIX MONTHS** from the date of this final action.

Art Unit: 3627

Any inquiry concerning this communication or earlier communications from the examiner should be directed to James A. Kramer whose telephone number is (703) 305-5241. The examiner can normally be reached on Monday - Friday (8AM - 5PM).

If attempts to reach the examiner by telephone are unsuccessful, the examiner's supervisor, Richard Chilcot can be reached on (703) 305-4716. The fax phone number for the organization where this application or proceeding is assigned is 703-872-9306.

Information regarding the status of an application may be obtained from the Patent Application Information Retrieval (PAIR) system. Status information for published applications may be obtained from either Private PAIR or Public PAIR. Status information for unpublished applications is available through Private PAIR only. For more information about the PAIR system, see <http://pair-direct.uspto.gov>. Should you have questions on access to the Private PAIR system, contact the Electronic Business Center (EBC) at 866-217-9197 (toll-free).

James A. Kramer
Examiner
Art Unit 3627

JAK

Michael Cuff 2/6/04
MICHAEL CUFF
PRIMARY EXAMINER

| | | | |
|-----------------------------------|---------------------------------------|---|-------------|
| Notice of References Cited | Application/Control No. 09/953,335 | Applicant(s)/Patent Under Reexamination CHRISTENSEN ET AL. | |
| | Examiner James A. Kramer | Art Unit 3627 | Page 1 of 1 |

U.S. PATENT DOCUMENTS

| * | Document Number Country Code-Number-Kind Code | Date MM-YYYY | Name | Classification |
|---|--|-----------------|--------------------|----------------|
| A | US-5,438,355 A | 08-1995 | Palmer, Shelton L. | 725/110 |
| B | US- | | | |
| C | US- | | | |
| D | US- | | | |
| E | US- | | | |
| F | US- | | | |
| G | US- | | | |
| H | US- | | | |
| I | US- | | | |
| J | US- | | | |
| K | US- | | | |
| L | US- | | | |
| M | US- | | | |

FOREIGN PATENT DOCUMENTS

| * | Document Number Country Code-Number-Kind Code | Date MM-YYYY | Country | Name | Classification |
|---|--|-----------------|---------|------|----------------|
| N | | | | | |
| O | | | | | |
| P | | | | | |
| Q | | | | | |
| R | | | | | |
| S | | | | | |
| T | | | | | |

NON-PATENT DOCUMENTS

| * | Include as applicable: Author, Title Date, Publisher, Edition or Volume, Pertinent Pages) |
|---|---|
| U | |
| V | |
| W | |
| X | |

*A copy of this reference is not being furnished with this Office action. (See MPEP § 707.05(a).)
Dates in MM-YYYY format are publication dates. Classifications may be US or foreign.

| | | | |
|--------------------------|--------------------------------------|---|-----|
| Interview Summary | Application No. 09/953,335 | Applicant(s) CHRISTENSEN ET AL. | |
| | Examiner James A. Kramer | Art Unit 3627 | #11 |

All participants (applicant, applicant's representative, PTO personnel):

- (1) James A. Kramer. (3) _____.
- (2) William Bunker. (4) _____.

Date of Interview: 01 April 2004.

Type: a) Telephonic b) Video Conference
c) Personal [copy given to: 1) applicant 2) applicant's representative]

Exhibit shown or demonstration conducted: d) Yes e) No.
If Yes, brief description: _____.

Claim(s) discussed: 1.

Identification of prior art discussed: US Patent Number 5,438,355 to Palmer and US Patent Number 5,303,393 to Noreen et al..

Agreement with respect to the claims f) was reached. g) was not reached. h) N/A.

Substance of Interview including description of the general nature of what was agreed to if an agreement was reached, or any other comments: Discussed some proposed amendments to claim 1. Agreed that with the proper ammendment the claim overcome the current rejection in view of Palmer as well as any combination of Palmer and Noreen et al. Futher search would then be required.

(A fuller description, if necessary, and a copy of the amendments which the examiner agreed would render the claims allowable, if available, must be attached. Also, where no copy of the amendments that would render the claims allowable is available, a summary thereof must be attached.)

THE FORMAL WRITTEN REPLY TO THE LAST OFFICE ACTION MUST INCLUDE THE SUBSTANCE OF THE INTERVIEW. (See MPEP Section 713.04). If a reply to the last Office action has already been filed, APPLICANT IS GIVEN ONE MONTH FROM THIS INTERVIEW DATE, OR THE MAILING DATE OF THIS INTERVIEW SUMMARY FORM, WHICHEVER IS LATER, TO FILE A STATEMENT OF THE SUBSTANCE OF THE INTERVIEW. See Summary of Record of Interview requirements on reverse side or on attached sheet.

Examiner Note: You must sign this form unless it is an Attachment to a signed Office action.

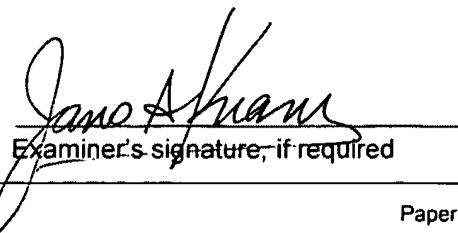
Examiner's signature, if required

Summary of Record of Interview Requirements

Manual of Patent Examining Procedure (MPEP), Section 713.04, Substance of Interview Must be Made of Record

A complete written statement as to the substance of any face-to-face, video conference, or telephone interview with regard to an application must be made of record in the application whether or not an agreement with the examiner was reached at the interview.

Title 37 Code of Federal Regulations (CFR) § 1.133 Interviews Paragraph (b)

In every instance where reconsideration is requested in view of an interview with an examiner, a complete written statement of the reasons presented at the interview as warranting favorable action must be filed by the applicant. An interview does not remove the necessity for reply to Office action as specified in §§ 1.111, 1.135. (35 U.S.C. 132)

37 CFR §1.2 Business to be transacted in writing.

All business with the Patent or Trademark Office should be transacted in writing. The personal attendance of applicants or their attorneys or agents at the Patent and Trademark Office is unnecessary. The action of the Patent and Trademark Office will be based exclusively on the written record in the Office. No attention will be paid to any alleged oral promise, stipulation, or understanding in relation to which there is disagreement or doubt.

The action of the Patent and Trademark Office cannot be based exclusively on the written record in the Office if that record is itself incomplete through the failure to record the substance of interviews.

It is the responsibility of the applicant or the attorney or agent to make the substance of an interview of record in the application file, unless the examiner indicates he or she will do so. It is the examiner's responsibility to see that such a record is made and to correct material inaccuracies which bear directly on the question of patentability.

Examiners must complete an Interview Summary Form for each interview held where a matter of substance has been discussed during the interview by checking the appropriate boxes and filling in the blanks. Discussions regarding only procedural matters, directed solely to restriction requirements for which interview recordation is otherwise provided for in Section 812.01 of the Manual of Patent Examining Procedure, or pointing out typographical errors or unreadable script in Office actions or the like, are excluded from the interview recordation procedures below. Where the substance of an interview is completely recorded in an Examiners Amendment, no separate Interview Summary Record is required.

The Interview Summary Form shall be given an appropriate Paper No., placed in the right hand portion of the file, and listed on the "Contents" section of the file wrapper. In a personal interview, a duplicate of the Form is given to the applicant (or attorney or agent) at the conclusion of the interview. In the case of a telephone or video-conference interview, the copy is mailed to the applicant's correspondence address either with or prior to the next official communication. If additional correspondence from the examiner is not likely before an allowance or if other circumstances dictate, the Form should be mailed promptly after the interview rather than with the next official communication.

The Form provides for recordation of the following information:

- Application Number (Series Code and Serial Number)
- Name of applicant
- Name of examiner
- Date of interview
- Type of interview (telephonic, video-conference, or personal)
- Name of participant(s) (applicant, attorney or agent, examiner, other PTO personnel, etc.)
- An indication whether or not an exhibit was shown or a demonstration conducted
- An identification of the specific prior art discussed
- An indication whether an agreement was reached and if so, a description of the general nature of the agreement (may be by attachment of a copy of amendments or claims agreed as being allowable). Note: Agreement as to allowability is tentative and does not restrict further action by the examiner to the contrary.
- The signature of the examiner who conducted the interview (if Form is not an attachment to a signed Office action)

It is desirable that the examiner orally remind the applicant of his or her obligation to record the substance of the interview of each case. It should be noted, however, that the Interview Summary Form will not normally be considered a complete and proper recordation of the interview unless it includes, or is supplemented by the applicant or the examiner to include, all of the applicable items required below concerning the substance of the interview.

A complete and proper recordation of the substance of any interview should include at least the following applicable items:

- 1) A brief description of the nature of any exhibit shown or any demonstration conducted,
- 2) an identification of the claims discussed,
- 3) an identification of the specific prior art discussed,
- 4) an identification of the principal proposed amendments of a substantive nature discussed, unless these are already described on the Interview Summary Form completed by the Examiner,
- 5) a brief identification of the general thrust of the principal arguments presented to the examiner,
(The identification of arguments need not be lengthy or elaborate. A verbatim or highly detailed description of the arguments is not required. The identification of the arguments is sufficient if the general nature or thrust of the principal arguments made to the examiner can be understood in the context of the application file. Of course, the applicant may desire to emphasize and fully describe those arguments which he or she feels were or might be persuasive to the examiner.)
- 6) a general indication of any other pertinent matters discussed, and
- 7) if appropriate, the general results or outcome of the interview unless already described in the Interview Summary Form completed by the examiner.

Examiners are expected to carefully review the applicant's record of the substance of an interview. If the record is not complete and accurate, the examiner will give the applicant an extendable one month time period to correct the record.

Examiner to Check for Accuracy

If the claims are allowable for other reasons of record, the examiner should send a letter setting forth the examiner's version of the statement attributed to him or her. If the record is complete and accurate, the examiner should place the indication, "Interview Record OK" on the paper recording the substance of the interview along with the date and the examiner's initials.

RECEIVED
CENTRAL FAX CENTER

OFFICIAL

AUG 12 2004

STRATOS.001A

PATENT

IN THE UNITED STATES PATENT AND TRADEMARK OFFICE

| | | |
|----------------|---|---|
| Applicant | : | Kelly Christensen et al. |
| Appl. No. | : | 09/953,335 |
| Filed | : | September 13, 2001 |
| For | : | SYSTEM AND METHOD FOR ORDERING AND DELIVERING MEDIA CONTENT |
| Examiner | : | James A. Kramer |
| Group Art Unit | : | 3627 |

CERTIFICATE OF FAX TRANSMISSION

I hereby certify that this correspondence and all marked attachments are being transmitted via facsimile to the USPTO Central Fax No. (703) 872-9306 on the date shown below:

August 12, 2004

 Perry D. Olgham, Reg. No. 52,082

AMENDMENT

Commissioner for Patents
P.O. Box 1450
Alexandria, VA 22313-1450

Dear Sir:

In response to a February 12, 2004 Office Action, Applicants respond as follows:

Amendments to the Claims are reflected in the listing of claims which begins on page 2 of this paper.

Remarks/Arguments begin on page 7 of this paper.

Appl. No. : 09/953,335
Filed : September 13, 2001

AMENDMENTS TO THE CLAIMS

1. (canceled)
2. (canceled)
3. (canceled)
4. (canceled)
5. (canceled)
6. (canceled)
7. (canceled)
8. (canceled)
9. (canceled)
10. (canceled)
11. (canceled)
12. (canceled)
13. (canceled)
14. (canceled)
15. (canceled)

16. (withdrawn): A response authentication system for processing requests sent in response to a data stream embedded within a broadcast radio signal, comprising:

a database that contains customer information;

a database that correlates a data stream identifier code with a location of the data stream on a communications network;

a server that correlates the receipt of a request for a specified data stream with information contained in the data stream location database, the request generated by user response to the broadcast radio signal having a program portion and a data portion, said data portion identifying said program portion; and

an order fulfillment server that receives communication of customer information.

17. (withdrawn): The system as in Claim 16, wherein a completed order results in a download of a file corresponding to the specified data stream.

18. (withdrawn): The system of Claim 16, wherein the data stream identifier code is extracted from identification information stored on a compact disc.

Appl. No. : 09/953,335
 Filed : September 13, 2001

19. (currently amended): A method of providing a response to a data stream embedded within associated with a broadcast channel, comprising, in no particular order:

obtaining information about a scheduled broadcast of at least one audio segment from a broadcaster;

generating identifying information about the audio stream segment that is to be transmitted over the broadcast channel;

communicating the audio stream identifier information the identifying information and an occurrence of the audio segment broadcast to a database;

using the database to determine a program unique reference tag corresponding to the occurrence of the identified audio stream; segment broadcast;

determining a broadcast source identifier tag corresponding to a broadcast station;

generating a data packet comprising based on the program unique reference tag, the a broadcast source identifier tag and a tag that identifies the source of the database source;

broadcasting the data packet as a first modulated signal stream and the audio stream segment as a second modulated signal stream;

demodulating extracting the data packet from the first modulated signal stream to extract the data packet;

demodulating generating an audio signal from the second modulated signal stream and generating an audio signal;

storing data corresponding to the extracted data packet in memory, the memory being capable of storing a plurality of entries;

communicating at least one entry from the memory to a user;

displaying the digital data corresponding to the data packet for viewing by a user;

determining a user identifier tag;

preparing, in response to user input, a response packet comprising the program unique reference tag, the broadcast source identifier tag, and the user identifier tag;

transmitting the response packet to a response authentication system; and

verifying the user identifier tag; and

acting on the response packet as directed by the verified user.

20. (canceled)

Appl. No. : 09/953,335
 Filed : September 13, 2001

21. (canceled)

22. (canceled)

23. (canceled)

24. (canceled)

25. (canceled)

26. (currently amended): A system for ~~performing a transaction based on~~ responding to data provided as part of a broadcast radio-frequency signal, comprising:

a means for identifying an audio segment that is to be transmitted over the broadcast channel;

a means for communicating the audio segment identifier information and an occurrence of the audio segment broadcast to a database;

a means for determining a unique reference tag corresponding to the occurrence of the identified audio segment broadcast;

a means for generating a data packet based on the unique reference tag, a broadcast source and the database source;

a means for broadcasting the data packet as a first signal stream and the audio segment as a second signal stream;

~~a means for receiving a data signal from a broadcast channel, said broadcast channel comprising an audio stream and a data stream that identifies program material in the audio stream;~~

a means for storing data corresponding to the extracted data packet;

~~a means for displaying~~ communicating information corresponding to the data signal to a user;

~~a means for allowing a~~ the user to select ~~a transaction~~ from the ~~displayed~~ communicated information;

~~a means for responding by providing requesting a transaction, said transaction request comprising an identity of a~~ the user and an identification of the ~~selected transaction, said transaction request being provided~~ selection to a response authentication system.

27. (new): The system of Claim 26, wherein the means for identifying an audio segment comprises a radio station playlist.

Appl. No. : 09/953,335
Filed : September 13, 2001

28. (new): The system of Claim 26, wherein the means for receiving a data signal comprises a radio receiver.

29. (new): The method of Claim 19, wherein the data packet comprises a broadcast source identifier tag.

30. (new): The method of Claim 19, wherein the data packet comprises a database source identifier tag.

31. (new): The method of Claim 19, wherein the first signal stream is modulated.

32. (new): The method of Claim 19, wherein the first signal stream is discrete from the second signal stream.

33. (new): The method of Claim 19, wherein the first signal stream is broadcast over a subcarrier channel.

34. (new): The method of Claim 19, wherein the transmitted response packet indicates that the user received the audio stream but did not respond.

35. (new): The method of Claim 19, further comprising selecting a communicated entry by user input.

36. (new): The method of Claim 35, wherein the selected entry is chosen from a plurality of communicated entries.

37. (new): The method of Claim 19, wherein the communicating step comprises displaying at least one entry to a user.

38. (new): The method of Claim 19, wherein the unique reference tag is based on the broadcaster source.

39. (new): The method of Claim 19, wherein the communicating step identifies a media file available for purchase.

40. (new): The method of Claim 19, further comprising receiving a media file corresponding to the response packet.

41. (new): The method of Claim 40, wherein the media file is received over a wireless network.

42. (new): The method of Claim 19, wherein transmitting the response packet comprises storing data on removable media.

43. (new): The method of Claim 19, wherein transmitting the response packet comprises transmitting data over a wireless network.

Appl. No. : 09/953,335
Filed : September 13, 2001

44. (new): The method of Claim 19, wherein transmitting the response packet comprises transmitting data over a short-length communications cable.

45. (new): The method of Claim 19, further comprising determining a broadcast source identifier tag corresponding to a broadcast station.

Appl. No. : 09/953,335
Filed : September 13, 2001

REMARKS

This communication is responsive to the February 12, 2004 Final Office Action. With this amendment, Claims 16-19 and 26-45 are currently pending, with Claims 16-18 being withdrawn from consideration. Claims 1-15 and 24-25 are canceled. Independent Claims 19 and 26, as currently amended, recite limitations not found in the prior art. No new matter is introduced by the current amendments. In view of the foregoing amendments and the following remarks, Applicants respectfully request reconsideration and allowance of this application.

Summary of the Interview

Applicants would like to thank Examiner Kramer for the courtesies extended to Applicants' counsel, William B. Bunker, in an April 1, 2004 interview. In accordance with MPEP § 713.04, a summary of the interview follows. Claim 1 was discussed, and Applicant's counsel presented arguments as to why U.S. Patent 5,438,355 issued to Palmer ("Palmer") and U.S. Patent 5,303,393 issued to Noreen et al. ("Noreen") do not anticipate or make obvious the claimed invention. No specific agreement was reached in the interview; however, the Examiner agreed to favorably consider the claims.

Summary of the Response

In a February 12, 2004 Final Office Action, Claims 1-11, 14-15 and 19-24 were rejected under 35 USC § 102 as being anticipated by Palmer. Claims 12-13 and 25 were rejected under 35 USC § 103 as being unpatentable over Palmer in view of Official Notice. The Office Action Summary indicated that Claim 26 was also rejected. Applicants have canceled Claims 1-15 and 20-25, amended Claims 19 and 26, and added Claims 27-45.

Claim 19

Independent Claim 19 was rejected under 35 USC § 102 as being anticipated by Palmer. Palmer fails to disclose the combination of limitations recited in amended Claim 19. For example, Claim 19 recites:

*obtaining information about a scheduled broadcast of at least one audio segment
from a broadcaster;*

Appl. No. : 09/953,335
Filed : September 13, 2001

generating identifying information about the audio segment that is to be transmitted over the broadcast channel;

communicating the identifying information and an occurrence of the audio segment broadcast to a database;

using the database to determine a unique reference tag corresponding to the occurrence of the identified audio segment broadcast;

Palmer discloses program identification codes (PICs) that are, for example, in the form of a vertical interval time code (VITC). See Palmer at 3:5-32. The embedding of vertical interval time codes occurs at the creation of a video segment, and these codes do not change on a real-time basis. Thus, the VITC embodiment disclosed by Palmer is a static system.

In contrast to the claimed invention, Palmer does not disclose obtaining information about a pending broadcast of at least one audio segment from a broadcaster; generating identifying information about the audio segment that is to be transmitted over the broadcast channel; communicating the identifying information and an occurrence of the audio segment broadcast to a database; and using the database to determine a unique reference tag corresponding to the occurrence of the identified audio segment broadcast.

Advantageously, an advertisement or program may be broadcast multiple times, and each broadcast may be given a unique reference tag. Because each broadcast may have its own unique reference tag, multiple broadcasts of the same audio segment can be distinguished. This provides, for example, improved tracking of responses based on individual time slots for the audio segment.

Claim 19, as amended, also recites "*generating a data packet based on the unique reference tag, a broadcast source and the database source.*" An audio segment, such as an advertisement or program, may be broadcast simultaneously on multiple broadcast channels. Including information about the broadcast source in the data packet allows for distinguishing between sources, even if the audio segment is the same. The possibility also exists that individual broadcasters may use different databases for storing information about the unique reference tag. Including information about the database source allows for identifying the correct

Appl. No. : 09/953,335
Filed : September 13, 2001

database to use. Palmer, in contrast, does not disclose *generating a data packet based on the unique reference tag, a broadcast source and the database source.*

Independent Claim 19 also recites:

broadcasting the data packet as a first signal stream and the audio segment as a second signal stream;
extracting the data packet from the first signal stream;
generating an audio signal from the second signal stream;

Palmer discloses a multiplexed broadcasting scheme where the PIC codes are transmitted in the same modulated signal stream as the TV signals. *See Palmer at 3:19-25.* Thus, the system disclosed by Palmer alternates between transmitting analog video data and digital PIC codes. The teachings of Palmer are incompatible with the claimed invention, because interrupting an analog audio broadcast to transmit digital data would degrade the sound quality of the audio.

Independent Claim 19 further recites:

storing data corresponding to the extracted data packet in memory, the memory being capable of storing a plurality of entries;
communicating at least one entry from the memory to a user;

Palmer, in contrast, does not disclose or suggest storing data corresponding to the extracted data packet in memory, the memory being capable of storing a plurality of entries; and communicating at least one entry from the memory to a user. Although Palmer does provide for storing *requested* data, this only occurs after the user has provided a response.

Further, Palmer describes pressing a response button when a viewer observes on the television receiver programming or a commercial advertising a product or service of interest. *See Palmer at 3:63-4:2.* This requires a real-time response. In fact, Palmer specifically states that it relates "to a system for processing viewer responses to television programming on a real time or pseudo real time basis." *Palmer at 1:7-10.* The invention recited in Claim 19, however, provides

Appl. No. : 09/953,335
Filed : September 13, 2001

for a delayed response to the broadcast, because the data is stored in memory. This may be advantageous, for example, if a user is operating a vehicle and desires to respond only when it is safe to do so.

Additionally, a viewer using the system described by Palmer may respond during a transition from one program to the next. The viewer would not know whether the transmitted response was for the previous program or the upcoming program. The ability to store and recall events for communication to a user, as recited in Claim 19, alleviates ambiguity in the user's response.

Claim 19 additionally recites "*determining a user identifier tag.*" Although Palmer discloses console identification codes (CIC), Palmer does not disclose determining a user identifier tag. Console information, such as a device serial number, is not the same as user information. Advantageously, transmitting the user identifier tag as claimed allows multiple users to use a single device. In contrast, the console identification code disclosed by Palmer does not provide any way to distinguish between multiple users of a single console.

These and other limitations recited in Claim 19 demonstrate the patentability of the claim, and allowance is respectfully requested.

Claim 26

Independent Claim 26 was rejected, although the Office Action did not provide any basis for the rejection. Applicants respectfully submit that Claim 26 as amended and its dependent claims are patentably distinct from the cited art.

Noreen et al.

The claims were previously rejected as being anticipated by U.S. Patent 5,303,393 to Noreen et al. ("Noreen"). Neither Noreen nor Palmer discloses the inventions as recited in the claims. Moreover, the claims as amended are not obvious in view of the combination of Palmer and Noreen. Noreen does not overcome the deficiencies of Palmer, as described above.

There must be some suggestion or motivation to combine the teachings of Noreen with the teachings of Palmer. Palmer relates to a system for processing viewer responses to television programming on a real time or pseudo real time basis, while Noreen relates to a radio system

Appl. No. : 09/953,335
Filed : September 13, 2001

using communication satellites and more particularly to a mobile satellite terminal. *See* Palmer at 1:7-10; Noreen at 1:12-19. Additionally, the television consoles as taught by Palmer are stationary, and the location of the console is always known. *See* Palmer at 1:44-47. In contrast, one of the objects of Noreen is to analyze signals to estimate positions of vehicles within one or two meters. *See* Noreen at 2:7-13. One of ordinary skill would not look to combine the mobile radio/satellite system of Noreen with the teachings of the stationary television/tower broadcast system of Palmer. Accordingly, the teachings of Palmer would not be combinable with the teachings of Noreen.

Grouping of Claims

The February 12, 2004 Final Office Action rejected Claims 1-11, 14-15 and 19-24 as a group, without specific references to limitations in the individual claims. Applicants respectfully traverse the grouping of the claims to make the rejection. *See* M.P.E.P. § 707.07(d). However, in an effort to narrow the issues for consideration by the Examiner, Applicants have canceled Claims 1-15 and 20-25. Applicants reserve the right to pursue the canceled claims in a continuing application.

Conclusion

Applicants have endeavored to address all of the Examiner's concerns as expressed in the outstanding Office Action. In view of the foregoing amendments and remarks, Applicants submit that the claims are patentably distinct from the cited art. Applicants respectfully submit that the claims are in condition for allowance. Furthermore, any remarks in support of patentability of one claim should not be imputed to any other claim, even if similar terminology is used. Any remarks referring to only a portion of a claim should not be understood to base patentability on that portion; rather, patentability must rest on each claim taken as a whole. Although changes to the claims have been made, no acquiescence or estoppel is or should be implied thereby; such amendments are made only to expedite prosecution of the present application and are without prejudice to the presentation or assertion, in the future, of claims relating to the same or similar subject matter.

If the Examiner finds any remaining impediment to the prompt allowance of these claims that could be clarified with a telephone conference, the Examiner is respectfully requested to

Appl. No. : 09/953,335
Filed : September 13, 2001

initiate the same with the undersigned attorney of record at his direct dial number of (949) 721-2961.

Please charge any additional fees, including any fees for additional extension of time, or credit overpayment to Deposit Account No. 11-1410.

Respectfully submitted,

KNOBBE, MARTENS, OLSON & BEAR, LLP

Dated: August 12, 2004

By: Perry Oldham
Perry D. Oldham
Registration No. 52,082
Attorney of Record
Customer No. 20,995
(949) 760-0404

H:\DOCS\PDOW\PDO-2379.DOC
081204

PATENT

Attorney Docket No.: STRATOS.001A

Date: August 12, 2004

Page 1

REQUEST FOR CONTINUED EXAMINATION (RCE)
UNDER 37 C.F.R. § 1.114

Applicant: Kelly Christensen et al.
Application Number: 09/953,335
Filing Date: September 13, 2001
Title: SYSTEM AND METHOD FOR ORDERING AND DELIVERING MEDIA CONTENT
Examiner Name: James A. Kramer
Group Art Unit: 3627

CERTIFICATE OF FAX TRANSMISSION

I hereby certify that this correspondence and all marked attachments are being transmitted via facsimile to the USPTO Central Fax No. (703) 872-9306 on the date shown below:

August 12, 2004

Perry D Oldham
Perry D Oldham, Reg. No. 52,082

Commissioner for Patents
P.O. Box 1450
Mail Stop RCE
Alexandria, VA 22313-1450

This is a Request for Continued Examination (RCE) under 37 C.F.R. § 1.114 of the above-identified application.

1. Submission Required under 37 C.F.R. § 1.114:

- (X) Enclosed:
(X) Amendment/Reply

2. Fees:

- (X) RCE fee (\$385 small entity/\$770 large entity)
(X) Extension of Time fee:
(X) Three Month (\$475/\$950)

3. Payment:

- (X) The Commissioner is hereby authorized to charge fees under 37 C.F.R. § 1.16 and § 1.17 which may be required, now or in the future, or credit any overpayment to Deposit Account No. 11-1410.

Address all future communications to Customer No. 20,995.

Dated: August 12, 2004

Perry D Oldham
Perry D. Oldham
Registration No. 52,082
Attorney of Record
Customer No. 20,995
(949) 760-0404

H:\DOCS\VPDO\PDO-2377.DOC
080904

AUG 12 2004

Knobbe Martens Olson & Bear LLP

Intellectual Property Law

OFFICIAL

2040 Main Street
Fourteenth Floor
Irvine, CA 92614
Tel 949-760-0404
Fax 949-760-9502
www.kmob.com

USPTO FACSIMILE TRANSMITTAL SHEET

Page 1 of 2

Docket No.: STRATOS.001A

CUSTOMER NO. 20995

Applicant : Kelly Christensen et al.
 App. No. : 09/953,335
 Filed : September 13, 2001
 For : SYSTEM AND METHOD FOR
 ORDERING AND DELIVERING MEDIA
 CONTENT
 Examiner : James A. Kramer
 Group Art Unit : 3627

CERTIFICATE OF FAX TRANSMISSION

I hereby certify that this correspondence and all marked attachments are being transmitted via facsimile to the USPTO Central Fax No. (703) 872-9306 on the date shown below:

August 12, 2004

Perry D. Oldham
Perry D. Oldham, Reg. No. 52,082

Transmitted herewith for filing and consideration in the above-referenced application are the following items:

- (X) Amendment/Response in 12 pages.
 - () Non-Final
 - (X) After Final
- (X) Request for Continued Examination

FILING FEES:

| FEE CALCULATION | | | | |
|--|----------------|--------------|----------------------|---------|
| FEE TYPE | | FEE CODE | CALCULATION | TOTAL |
| 3 Month Extension | | 1253 (\$950) | | \$950 |
| RCE | 37 CFR § 1.114 | | | \$770 |
| | | | SUB TOTAL | \$1,720 |
| The present application qualifies for Small Entity status under 37 CFR § 1.27. Fee reduced by 1/2. | | | | (\$860) |
| | | | TOTAL FEE DUE | \$860 |

(X) Please charge the total fees due in the amount of \$860 to Deposit Account No. 11-1410.

San Diego
619-235-8550

San Francisco
415-954-4114

Los Angeles
310-551-3450

Riverside
951-781-9231

San Luis Obispo
805-547-5580

~~Knobbe Martens Olson & Bear LLP~~

Application No.: 09/953,335
Filing Date: September 13, 2001

CUSTOMER NO. 20995

(X) Total pages in transmission: 15

The Commissioner is hereby authorized to charge any additional fees which may be required, now or in the future, or credit any overpayment to Account No. 11-1410.



Perry D. Oldham
Registration No. 52,082
Attorney of Record
Customer No. 20,995
(949) 760-0404

H:\DOCS\PDOPDO-2378.DOC
081104

PATENT APPLICATION FEE DETERMINATION RECORD
Effective October 1, 2001

Application or Docket Number

09953335

CLAIMS AS FILED - PART I

| | | (Column 1) | (Column 2) |
|---|--------------|------------|--------------|
| TOTAL CLAIMS | | | |
| FOR | NUMBER FILED | | NUMBER EXTRA |
| TOTAL CHARGEABLE CLAIMS | | minus 20= | * |
| INDEPENDENT CLAIMS | | minus 3 = | * |
| MULTIPLE DEPENDENT CLAIM PRESENT <input type="checkbox"/> | | | |

* If the difference in column 1 is less than zero, enter "0" in column 2

SMALL ENTITY TYPE OR

| RATE | FEE |
|-----------|--------|
| BASIC FEE | 370.00 |
| X\$ 9= | |
| X42= | |
| +140= | |
| TOTAL | |

OTHER THAN SMALL ENTITY

| RATE | FEE |
|-----------|--------|
| BASIC FEE | 740.00 |
| X\$18= | |
| X84= | |
| +280= | |
| TOTAL | |

CLAIMS AS AMENDED - PART II

| | | (Column 1) | (Column 2) | (Column 3) |
|---|-------------|----------------------------------|------------------------------------|---------------|
| AMENDMENT A | | CLAIMS REMAINING AFTER AMENDMENT | HIGHEST NUMBER PREVIOUSLY PAID FOR | PRESENT EXTRA |
| | Total | * 24 | Minus 26 | = 2 |
| | Independent | * 3 | Minus *** 8 | = 5 |
| FIRST PRESENTATION OF MULTIPLE DEPENDENT CLAIM <input type="checkbox"/> | | | | |

SMALL ENTITY OR

| RATE | ADDITIONAL FEE |
|------------------|----------------|
| X\$ 9= | |
| X42= | |
| +140= | |
| TOTAL ADDIT. FEE | |

OTHER THAN SMALL ENTITY

| RATE | ADDITIONAL FEE |
|------------------|----------------|
| X\$18= | |
| X84= | |
| +280= | |
| TOTAL ADDIT. FEE | |

| | | (Column 1) | (Column 2) | (Column 3) |
|---|-------------|----------------------------------|------------------------------------|---------------|
| AMENDMENT B | | CLAIMS REMAINING AFTER AMENDMENT | HIGHEST NUMBER PREVIOUSLY PAID FOR | PRESENT EXTRA |
| | Total | * | Minus ** | = |
| | Independent | * | Minus *** | = |
| FIRST PRESENTATION OF MULTIPLE DEPENDENT CLAIM <input type="checkbox"/> | | | | |

| RATE | ADDITIONAL FEE |
|------------------|----------------|
| X\$ 9= | |
| X42= | |
| +140= | |
| TOTAL ADDIT. FEE | |

| RATE | ADDITIONAL FEE |
|------------------|----------------|
| X\$18= | |
| X84= | |
| +280= | |
| TOTAL ADDIT. FEE | |

| | | (Column 1) | (Column 2) | (Column 3) |
|---|-------------|----------------------------------|------------------------------------|---------------|
| AMENDMENT C | | CLAIMS REMAINING AFTER AMENDMENT | HIGHEST NUMBER PREVIOUSLY PAID FOR | PRESENT EXTRA |
| | Total | * | Minus ** | = |
| | Independent | * | Minus *** | = |
| FIRST PRESENTATION OF MULTIPLE DEPENDENT CLAIM <input type="checkbox"/> | | | | |

| RATE | ADDITIONAL FEE |
|------------------|----------------|
| X\$ 9= | |
| X42= | |
| +140= | |
| TOTAL ADDIT. FEE | |

| RATE | ADDITIONAL FEE |
|------------------|----------------|
| X\$18= | |
| X84= | |
| +280= | |
| TOTAL ADDIT. FEE | |

* If the entry in column 1 is less than the entry in column 2, write "0" in column 3.
 ** If the "Highest Number Previously Paid For" IN THIS SPACE is less than 20, enter "20."
 *** If the "Highest Number Previously Paid For" IN THIS SPACE is less than 3, enter "3."
 The "Highest Number Previously Paid For" (Total or Independent) is the highest number found in the appropriate box in column 1.

8-12-04



UNITED STATES PATENT AND TRADEMARK OFFICE

UNITED STATES DEPARTMENT OF COMMERCE
United States Patent and Trademark Office
Address: COMMISSIONER FOR PATENTS
P.O. Box 1450
Alexandria, Virginia 22313-1450
www.uspto.gov

| APPLICATION NO. | FILING DATE | FIRST NAMED INVENTOR | ATTORNEY DOCKET NO. | CONFIRMATION NO. |
|-----------------|-------------|----------------------|---------------------|------------------|
| 09/953,335 | 09/13/2001 | Kelly M. Christensen | STRATOS.001A | 4917 |

20995 7590 11/15/2004

KNOBBE MARTENS OLSON & BEAR LLP
2040 MAIN STREET
FOURTEENTH FLOOR
IRVINE, CA 92614

EXAMINER

KRAMER, JAMES A

ART UNIT PAPER NUMBER

3627

DATE MAILED: 11/15/2004

Please find below and/or attached an Office communication concerning this application or proceeding.

Office Action Summary

| | | |
|--------------------------------------|---|--|
| Application No. 09/953,335 | Applicant(s) CHRISTENSEN ET AL. | |
| Examiner James A. Kramer | Art Unit 3627 | |

-- The MAILING DATE of this communication appears on the cover sheet with the correspondence address --

Period for Reply

A SHORTENED STATUTORY PERIOD FOR REPLY IS SET TO EXPIRE 3 MONTH(S) FROM THE MAILING DATE OF THIS COMMUNICATION.

- Extensions of time may be available under the provisions of 37 CFR 1.136(a). In no event, however, may a reply be timely filed after SIX (6) MONTHS from the mailing date of this communication.
- If the period for reply specified above is less than thirty (30) days, a reply within the statutory minimum of thirty (30) days will be considered timely.
- If NO period for reply is specified above, the maximum statutory period will apply and will expire SIX (6) MONTHS from the mailing date of this communication.
- Failure to reply within the set or extended period for reply will, by statute, cause the application to become ABANDONED (35 U.S.C. § 133). Any reply received by the Office later than three months after the mailing date of this communication, even if timely filed, may reduce any earned patent term adjustment. See 37 CFR 1.704(b).

Status

- 1) Responsive to communication(s) filed on 12 August 2004.
- 2a) This action is FINAL.
- 2b) This action is non-final.
- 3) Since this application is in condition for allowance except for formal matters, prosecution as to the merits is closed in accordance with the practice under *Ex parte Quayle*, 1935 C.D. 11, 453 O.G. 213.

Disposition of Claims

- 4) Claim(s) 19 and 26-45 is/are pending in the application.
 - 4a) Of the above claim(s) _____ is/are withdrawn from consideration.
- 5) Claim(s) _____ is/are allowed.
- 6) Claim(s) 19 and 26-45 is/are rejected.
- 7) Claim(s) _____ is/are objected to.
- 8) Claim(s) _____ are subject to restriction and/or election requirement.

Application Papers

- 9) The specification is objected to by the Examiner.
- 10) The drawing(s) filed on _____ is/are: a) accepted or b) objected to by the Examiner.
Applicant may not request that any objection to the drawing(s) be held in abeyance. See 37 CFR 1.85(a).
Replacement drawing sheet(s) including the correction is required if the drawing(s) is objected to. See 37 CFR 1.121(d).
- 11) The oath or declaration is objected to by the Examiner. Note the attached Office Action or form PTO-152.

Priority under 35 U.S.C. § 119

- 12) Acknowledgment is made of a claim for foreign priority under 35 U.S.C. § 119(a)-(d) or (f).
 - a) All b) Some * c) None of:
 - 1. Certified copies of the priority documents have been received.
 - 2. Certified copies of the priority documents have been received in Application No. _____.
 - 3. Copies of the certified copies of the priority documents have been received in this National Stage application from the International Bureau (PCT Rule 17.2(a)).

* See the attached detailed Office action for a list of the certified copies not received.

Attachment(s)

- 1) Notice of References Cited (PTO-892)
- 2) Notice of Draftsperson's Patent Drawing Review (PTO-948)
- 3) Information Disclosure Statement(s) (PTO-1449 or PTO/SB/08)
Paper No(s)/Mail Date _____.
- 4) Interview Summary (PTO-413)
Paper No(s)/Mail Date _____.
- 5) Notice of Informal Patent Application (PTO-152)
- 6) Other: _____.

DETAILED ACTION

Claim Rejections - 35 USC § 103

The following is a quotation of 35 U.S.C. 103(a) which forms the basis for all obviousness rejections set forth in this Office action:

(a) A patent may not be obtained though the invention is not identically disclosed or described as set forth in section 102 of this title, if the differences between the subject matter sought to be patented and the prior art are such that the subject matter as a whole would have been obvious at the time the invention was made to a person having ordinary skill in the art to which said subject matter pertains. Patentability shall not be negated by the manner in which the invention was made.

Claims 19 and 26-45 are rejected under 35 U.S.C. 103(a) as being unpatentable over Palmer in view of Official Notice.

Palmer teaches an interactive system for processing viewer responses to television programming. The interactive system of the invention comprises a central exchange where a database is stored (i.e. program history database). This database contains a plurality program identification codes (PIC codes) in the form of data uniquely identifying each program or portions of programs broadcasted to television receivers by a broadcaster (unique program reference tag corresponding to digital identifying information about program material) (column 1; lines 42-45 and column 3; lines 5-12).

Palmer teaches that the PIC codes are transmitted in conjunction with the TV signals (column 3; lines 19-31). Examiner notes that in order for the PIC codes to be transmitted in conjunction with the TV signals, the system of Palmer must, inherently include a broadcast data encoder.

Palmer further teaches a user console with a code reader which is cable of reading the codes embedded in the TV signal (column 3; lines 44-45). Examiner notes that the code reader corresponds to Applicant's broadcast receiver. In addition, Examiner notes that the TV signal

Art Unit: 3627

embedded with PIC codes of Palmer corresponds to a broadcast channel comprising audio stream and a broadcast data stream, wherein the data stream comprises the unique program reference tag (PIC codes).

Palmer further teaches connected to each coder reader is a keypad and Liquid Crystal Display (column 3; lines 51-52). When a user views a program or commercial for a product or service of interest, he or she presses the appropriate response button to generate a viewer response signal. The system then establishes a communications link with the central exchange and transmits PIC codes together with console identification codes (CIC codes) and user encoded data to the computer of the central exchange (column 3; line 63 – column 4; line 9). (display, user input and first output module).

Palmer then teaches, on the basis of the received PIC and CIC codes, computer searches database to locate matching PIC and CIC codes (first and second comparator) (column 4; lines 10-14 and column 2; lines 61-67). After verifying the PIC and CIC codes the system retrieves from the database, specific program data associated with the PIC code and specific user data associated with the CIC code. Using the received console (user) data the retrieved program data is sent to the responding viewer (column 2; lines 1-6). Examiner notes this corresponds to second output module that generates a fulfillment signal.

Claim Rejections - 35 USC § 103

The following is a quotation of 35 U.S.C. 103(a) which forms the basis for all obviousness rejections set forth in this Office action:

(a) A patent may not be obtained though the invention is not identically disclosed or described as set forth in section 102 of this title, if the differences between the subject matter sought to be patented and the prior art are such that the subject matter as a whole would have been obvious at the time the invention was made to a person having ordinary skill in the art to which said subject matter pertains. Patentability shall not be negated by the manner in which the invention was made.

Art Unit: 3627

Claims 12-13 and 25 are rejected under 35 U.S.C. 103(a) as being unpatentable over Palmer in view of Official Notice.

Palmer as described above does not teach the data stream conforming to the Radio Broadcast Data System Standard. Examiner takes Official Notice that the RBDS is an old and well known sub carrier for radio broadcasts and which provides a means for transmitting data signals along with a radio broadcast.

It would have been obvious to a person of ordinary skill in the art at the time the invention was made to modify the system of Palmer by transmitting the PIC Codes using the RBDS standard along with a radio broadcast in order to reach radio listeners as well as TV viewers.

Applicant's arguments filed 2/12/04 have been fully considered but they are not persuasive. Applicant asserts that Palmer fails to provide responses based on individual time slots. Examiner disagrees and asserts that if this were necessary, a user of the invention of Palmer could develop an individual PIC for each program in order to identify the programming by time slot. As a result this capability does exist within the scope of the invention of Palmer.

Applicant asserts that Palmer fails to teach that the data packet includes a reference to the database source. Examiner argues that this is inherently part of the PIC. In other words, the PIC number uniquely ties the data sent with the database source and thus is part of this data packet.

Applicant asserts that Palmer does not teach a first and second signal stream and points to Palmer 3:19-25. Examiner notes that this section specifically states that Palmer may be in the form of the vertical interval. This does not teach away from the concept of separate signal streams.

Art Unit: 3627

Applicant asserts that Palmer does not store data corresponding to the extracted data packet. Examiner notes that Palmer does teach a VCR application of the system. In which I user could store or save the program and the data corresponding to the data packet.

Conclusion

Any inquiry concerning this communication or earlier communications from the examiner should be directed to James A. Kramer whose telephone number is (703) 305-5241. The examiner can normally be reached on Monday - Friday (8AM - 5PM).

If attempts to reach the examiner by telephone are unsuccessful, the examiner's supervisor, Richard Chilcot can be reached on (703) 305-4716. The fax phone number for the organization where this application or proceeding is assigned is 703-872-9306.

Information regarding the status of an application may be obtained from the Patent Application Information Retrieval (PAIR) system. Status information for published applications may be obtained from either Private PAIR or Public PAIR. Status information for unpublished applications is available through Private PAIR only. For more information about the PAIR system, see <http://pair-direct.uspto.gov>. Should you have questions on access to the Private PAIR system, contact the Electronic Business Center (EBC) at 866-217-9197 (toll-free).

James A. Kramer
Examiner
Art Unit 3627

JAK

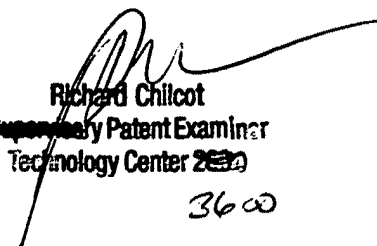
Richard Chilcot
Supervisory Patent Examiner
Technology Center 2820
3600

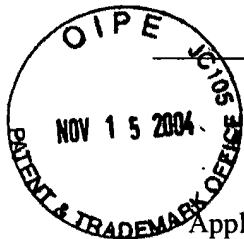

IN THE UNITED STATES PATENT AND TRADEMARK OFFICE

Applicant : Christensen et al.
 Appl. No. : 09/953,335
 Filed : September 13, 2001
 For : SYSTEM AND METHOD FOR ORDERING AND DELIVERING MEDIA CONTENT
 Examiner : James Kramer
 Group Art Unit : 3627

I hereby certify that this correspondence and all marked attachments are being deposited with the United States Postal Service as first class mail in an envelope addressed to: Commissioner for Patents, Mail Stop Amendment, P.O. Box 1450, Alexandria, VA 22313-1450, on

November 10, 2004

(Date)

Perry Oldham

Perry D. Oldham, Reg. No. 52,082

TRANSMITTAL LETTER

Mail Stop Amendment
 Commissioner for Patents
 P.O. Box 1450
 Alexandria, VA 22313-1450

Dear Sir:

Enclosed for filing in the above-identified application are:

- (X) An Information Disclosure Statement.
- (X) A PTO Form 1449 with two (2) references.
- (X) The Commissioner is hereby authorized to charge any additional fees which may be required, or credit any overpayment, to Account No. 11-1410.
- (X) Return prepaid postcard.

Perry Oldham
 Perry D. Oldham
 Registration No. 52,082
 Attorney of Record
 Customer No. 20,995
 (949) 760-0404

INFORMATION DISCLOSURE STATEMENT

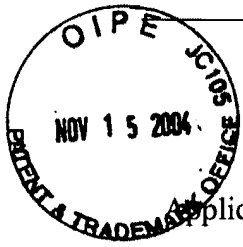

Applicant : Christensen et al.
Appl. No. : 09/953,335
Filed : September 13, 2001
For : SYSTEM AND METHOD FOR
ORDERING AND DELIVERING MEDIA
CONTENT
Examiner : James Kramer
Group Art Unit : 3627

Mail Stop Amendment
Commissioner for Patents
P.O. Box 1450
Alexandria, VA 22313-1450

Dear Sir:

Enclosed is form PTO-1449 listing 2 (two) references that are enclosed.

This Information Disclosure Statement is being filed before the receipt of a first Office Action on the merits, and presumably no fee is required in accordance with 37 C.F.R. § 1.97(b)(3). If a first Office Action on the merits was mailed before the mailing date of this Statement, the Commissioner is authorized to charge the fee set forth in 37 C.F.R. § 1.17(p) to Deposit Account No. 11-1410.

Respectfully submitted,

KNOBBE, MARTENS, OLSON & BEAR, LLP

Dated: 11/10/2004

By: Perry Oldham

Perry D. Oldham
Registration No. 52,082
Attorney of Record
Customer No. 20,995
(949) 760-0404

| | | |
|--|-----------------------------------|-------------------------------|
| FORM PTO-1449 U.S. DEPARTMENT OF COMMERCE PATENT AND TRADEMARK OFFICE INFORMATION DISCLOSURE STATEMENT BY APPLICANT (USE SEVERAL SHEETS IF NECESSARY) | ATTY. DOCKET NO. STRATOS.001A | APPLICATION NO. 09/953,335 |
| | APPLICANT Christensen et al | |
| | FILING DATE September 13, 2001 | GROUP 3627 |

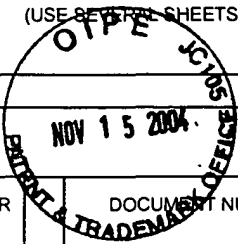

| U.S. PATENT DOCUMENTS | | | | | | |
|-----------------------|-----------------|---------|-----------------|-------|----------|------------------------------|
| EXAMINER INITIAL | DOCUMENT NUMBER | DATE | NAME | CLASS | SUBCLASS | FILING DATE (IF APPROPRIATE) |
| 1 | 2003/0097338 A1 | 5/22/03 | Mankovich et al | | | |
| | | | | | | |
| | | | | | | |
| | | | | | | |

| EXAMINER INITIAL | OTHER DOCUMENTS (INCLUDING AUTHOR, TITLE, DATE, PERTINENT PAGES, ETC.) |
|------------------|---|
| 2 | U.S. Patent Appl No. 10/806,084, filed March 22, 2004; Preliminary Amendment filed on 7/21/04 |
| | |
| | |
| | |

H:\DOCS\PDO\PDO-2434.DOC
111004

| | |
|--|-----------------|
| EXAMINER | DATE CONSIDERED |
| *EXAMINER: INITIAL IF CITATION CONSIDERED, WHETHER OR NOT CITATION IS IN CONFORMANCE WITH MPEP 609; DRAW LINE THROUGH CITATION IF NOT IN CONFORMANCE AND NOT CONSIDERED, INCLUDE COPY OF THIS FORM WITH NEXT COMMUNICATION TO APPLICANT. | |

Summary of Record of Interview Requirements

Manual of Patent Examining Procedure (MPEP), Section 713.04, Substance of Interview Must be Made of Record

A complete written statement as to the substance of any face-to-face, video conference, or telephone interview with regard to an application must be made of record in the application whether or not an agreement with the examiner was reached at the interview.

Title 37 Code of Federal Regulations (CFR) § 1.133 Interviews

Paragraph (b)

In every instance where reconsideration is requested in view of an interview with an examiner, a complete written statement of the reasons presented at the interview as warranting favorable action must be filed by the applicant. An interview does not remove the necessity for reply to Office action as specified in §§ 1.111, 1.135. (35 U.S.C. 132)

37 CFR §1.2 Business to be transacted in writing.

All business with the Patent or Trademark Office should be transacted in writing. The personal attendance of applicants or their attorneys or agents at the Patent and Trademark Office is unnecessary. The action of the Patent and Trademark Office will be based exclusively on the written record in the Office. No attention will be paid to any alleged oral promise, stipulation, or understanding in relation to which there is disagreement or doubt.

The action of the Patent and Trademark Office cannot be based exclusively on the written record in the Office if that record is itself incomplete through the failure to record the substance of interviews.

It is the responsibility of the applicant or the attorney or agent to make the substance of an interview of record in the application file, unless the examiner indicates he or she will do so. It is the examiner's responsibility to see that such a record is made and to correct material inaccuracies which bear directly on the question of patentability.

Examiners must complete an Interview Summary Form for each interview held where a matter of substance has been discussed during the interview by checking the appropriate boxes and filling in the blanks. Discussions regarding only procedural matters, directed solely to restriction requirements for which interview recordation is otherwise provided for in Section 812.01 of the Manual of Patent Examining Procedure, or pointing out typographical errors or unreadable script in Office actions or the like, are excluded from the interview recordation procedures below. Where the substance of an interview is completely recorded in an Examiners Amendment, no separate Interview Summary Record is required.

The Interview Summary Form shall be given an appropriate Paper No., placed in the right hand portion of the file, and listed on the "Contents" section of the file wrapper. In a personal interview, a duplicate of the Form is given to the applicant (or attorney or agent) at the conclusion of the interview. In the case of a telephone or video-conference interview, the copy is mailed to the applicant's correspondence address either with or prior to the next official communication. If additional correspondence from the examiner is not likely before an allowance or if other circumstances dictate, the Form should be mailed promptly after the interview rather than with the next official communication.

The Form provides for recordation of the following information:

- Application Number (Series Code and Serial Number)
- Name of applicant
- Name of examiner
- Date of interview
- Type of interview (telephonic, video-conference, or personal)
- Name of participant(s) (applicant, attorney or agent, examiner, other PTO personnel, etc.)
- An indication whether or not an exhibit was shown or a demonstration conducted
- An identification of the specific prior art discussed
- An indication whether an agreement was reached and if so, a description of the general nature of the agreement (may be by attachment of a copy of amendments or claims agreed as being allowable). Note: Agreement as to allowability is tentative and does not restrict further action by the examiner to the contrary.
- The signature of the examiner who conducted the interview (if Form is not an attachment to a signed Office action)

It is desirable that the examiner orally remind the applicant of his or her obligation to record the substance of the interview of each case. It should be noted, however, that the Interview Summary Form will not normally be considered a complete and proper recordation of the interview unless it includes, or is supplemented by the applicant or the examiner to include, all of the applicable items required below concerning the substance of the interview.

A complete and proper recordation of the substance of any interview should include at least the following applicable items:

- 1) A brief description of the nature of any exhibit shown or any demonstration conducted,
- 2) an identification of the claims discussed,
- 3) an identification of the specific prior art discussed,
- 4) an identification of the principal proposed amendments of a substantive nature discussed, unless these are already described on the Interview Summary Form completed by the Examiner,
- 5) a brief identification of the general thrust of the principal arguments presented to the examiner,
(The identification of arguments need not be lengthy or elaborate. A verbatim or highly detailed description of the arguments is not required. The identification of the arguments is sufficient if the general nature or thrust of the principal arguments made to the examiner can be understood in the context of the application file. Of course, the applicant may desire to emphasize and fully describe those arguments which he or she feels were or might be persuasive to the examiner.)
- 6) a general indication of any other pertinent matters discussed, and
- 7) if appropriate, the general results or outcome of the interview unless already described in the Interview Summary Form completed by the examiner.

Examiners are expected to carefully review the applicant's record of the substance of an interview. If the record is not complete and accurate, the examiner will give the applicant an extendable one month time period to correct the record.

Examiner to Check for Accuracy

If the claims are allowable for other reasons of record, the examiner should send a letter setting forth the examiner's version of the statement attributed to him or her. If the record is complete and accurate, the examiner should place the indication, "Interview Record OK" on the paper recording the substance of the interview along with the date and the examiner's initials.

Appl. No. : 09/953,335
Filed : September 13, 2001

obtained info
identifying info - based on the obtained info - a
identifying info comprises

19. (currently amended): A method of providing a response to a data stream embedded within associated with a broadcast channel, comprising, in no particular order:

obtaining information about a scheduled broadcast of at least one audio segment from a broadcaster; *the obtained info comprising the audio segment*

generating identifying an information about the audio stream segment that is to be transmitted over the broadcast channel;

communicating the audio stream identifier information the identifying information and an occurrence of the audio segment broadcast to a database;

using the database to determine a program unique reference tag corresponding to the occurrence of the identified audio stream; segment broadcast; *the obtained info*

determining a broadcast source identifier tag corresponding to a broadcast station;

generating a data packet comprising based on the program unique reference tag, the broadcast source identifier tag and a tag that identifies the source of the database; *or identifier a*

submitting the data packet to the broadcaster; *source;*
broadcasting the data packet as a first modulated signal stream and the audio stream segment as a second modulated signal stream;

demodulating extracting the data packet from the first modulated signal stream to extract the data packet; *at a user terminal*

demodulating generating an audio signal from the second modulated signal stream and generating an audio signal;

storing data corresponding to the extracted data packet, in memory, the memory being capable of storing a plurality of entries; *in memory at the user terminal*

communicating at least one entry from the memory to a user;

displaying the digital data corresponding to the data packet for viewing by a user;

determining a user identifier tag;

preparing, in response to user input, a response packet comprising the program unique reference tag, the broadcast source identifier tag, and the user identifier tag;

transmitting the response packet to a response authentication system; and

verifying the user identifier tag; and

acting on the response packet as directed by the verified user.

20. (canceled)

how files;ds

File 348:EUROPEAN PATENTS 1978-2005/Feb W01

(c) 2005 European Patent Office

File 349:PCT FULLTEXT 1979-2002/UB=20050203,UT=20050127

(c) 2005 WIPO/Univentio

| Set | Items | Description |
|-----|--------|---|
| S1 | 141850 | RADIO? ? |
| S2 | 627 | (AM OR FM) () STATION? |
| S3 | 345659 | BROADCAST? OR PROGRAM? |
| S4 | 520 | (REALTIME OR IMMEDIAT? OR REAL()TIME? OR RIGHT()AWAY OR RI- GHTAWAY OR INSTANT?) (3N) (ORDER? OR PURCHAS? OR BUY?) (3N) (ITE- M? ? OR PRODUCT OR PRODUCTS OR MERCHANDIS?) |
| S5 | 30029 | (ORDER? OR PURCHAS? OR BUY?) (3N) (ITEM? ? OR PRODUCT OR PRO- DUCTS OR MERCHANDIS?) |
| S6 | 376758 | CAR OR CARS OR VEHICLE? OR AUTOMOBILE? |
| S7 | 14558 | (WHILE OR DURING) (3N) (DRIVING OR RIDING) |
| S8 | 0 | (S1 OR S2) (S) S4 (S) (S6 OR S7) |
| S9 | 97 | (S1 OR S2) (S) S5 (S) (S6 OR S7) |
| S10 | 66 | S9 NOT AD=>20010913 |
| S11 | 7 | (S1 OR S2) (S) S4 |
| S12 | 3 | S11 AND (S6 OR S7) |
| | ? | |

STIC SEARCH

EIC 3600

Karen Lehman EIC 3600 14-Feb-05

Petitioner Hyundai Ex-1024, 0449

show files;ds
File 347:JAPIO Nov 1976-2004/Oct(Updated 050208)
(c) 2005 JPO & JAPIO
File 350:Derwent WPIX 1963-2005/UD,UM &UP=200509
(c) 2005 Thomson Derwent
File 371:French Patents 1961-2002/BOPI 200209
(c) 2002 INPI. All rts. reserv.
File 344:Chinese Patents Abs Aug 1985-2004/May
(c) 2004 European Patent Office

| Set | Items | Description |
|-----|---------|---|
| S1 | 249243 | RADIO? ? |
| S2 | 111 | (AM OR FM) ()STATION? |
| S3 | 587437 | BROADCAST? OR PROGRAM? |
| S4 | 127 | (REALTIME OR IMMEDIAT? OR REAL()TIME? OR RIGHT()AWAY OR RI- GHTAWAY OR INSTANT?) (3N) (ORDER? OR PURCHAS? OR BUY?) (3N) (ITE- M? ? OR PRODUCT OR PRODUCTS OR MERCHANDIS?) |
| S5 | 11850 | (ORDER? OR PURCHAS? OR BUY?) (3N) (ITEM? ? OR PRODUCT OR PRO- DUCTS OR MERCHANDIS?) |
| S6 | 1469810 | CAR OR CARS OR VEHICLE? OR AUTOMOBILE? |
| S7 | 19660 | (WHILE OR DURING) (3N) (DRIVING OR RIDING) |
| S8 | 1 | (S1 OR S2) AND S4 AND (S6 OR S7) |
| S9 | 2 | (S1 OR S2) AND S4 |
| S10 | 1 | S9 NOT S8 |
| ? | | |

STIC Search

EK 3600

Karen Lehman EIC 3600 14-Feb-05

Petitioner Hyundai Ex-1024, 0450

show files;ds
 File 610:Business Wire 1999-2005/Feb 09
 (c) 2005 Business Wire.
 File 810:Business Wire 1986-1999/Feb 28
 (c) 1999 Business Wire
 File 476:Financial Times Fulltext 1982-2005/Feb 14
 (c) 2005 Financial Times Ltd
 File 624:McGraw-Hill Publications 1985-2005/Feb 14
 (c) 2005 McGraw-Hill Co. Inc
 File 634:San Jose Mercury Jun 1985-2005/Feb 12
 (c) 2005 San Jose Mercury News
 File 20:Dialog Global Reporter 1997-2005/Feb 14
 (c) 2005 The Dialog Corp.

| Set | Items | Description |
|-----|---------|---|
| S1 | 1694556 | RADIO? ? |
| S2 | 5193 | (AM OR FM) ()STATION? |
| S3 | 7632054 | BROADCAST? OR PROGRAM? |
| S4 | 3906 | (REALTIME OR IMMEDIAT? OR REAL()TIME? OR RIGHT()AWAY OR RI- GHTAWAY OR INSTANT?) (3N) (ORDER? OR PURCHAS? OR BUY?) (3N) (ITE- M? ? OR PRODUCT OR PRODUCTS OR MERCHANDIS?) |
| S5 | 258168 | (ORDER? OR PURCHAS? OR BUY?) (3N) (ITEM? ? OR PRODUCT OR PRO- DUCTS OR MERCHANDIS?) |
| S6 | 3050384 | CAR OR CARS OR VEHICLE? OR AUTOMOBILE? |
| S7 | 45739 | (WHILE OR DURING) (3N) (DRIVING OR RIDING) |
| S8 | 1 | (S1 OR S2) (7N)S3(7N)S4 |
| S9 | 8 | (S1 OR S2) (10N)S4 |
| S10 | 4 | S9 NOT PD=>20010913 |
| S11 | 4 | RD (unique items) |
| S12 | 2 | S11 AND S6 |

Stic Search

EIC 3600

Karen Lehman EIC 3600 14-Feb-05

Petitioner Hyundai Ex-1024, 0451

how files;ds

File 35:Dissertation Abs Online 1861-2005/Jan
(c) 2005 ProQuest Info&Learning
File 583:Gale Group Globalbase(TM) 1986-2002/Dec 13
(c) 2002 The Gale Group
File 65:Inside Conferences 1993-2005/Feb W2
(c) 2005 BLDSC all rts. reserv.
File 2:INSPEC 1969-2005/Feb W1
(c) 2005 Institution of Electrical Engineers
File 144:Pascal 1973-2005/Feb W1
(c) 2005 INIST/CNRS
File 474:New York Times Abs 1969-2005/Feb 13
(c) 2005 The New York Times
File 475:Wall Street Journal Abs 1973-2005/Feb 11
(c) 2005 The New York Times
File 99:Wilson Appl. Sci & Tech Abs 1983-2005/Jan
(c) 2005 The HW Wilson Co.

| Set | Items | Description |
|-----|---------|---|
| S1 | 424714 | RADIO? ? |
| S2 | 298 | (AM OR FM)()STATION? |
| S3 | 1701474 | BROADCAST? OR PROGRAM? |
| S4 | 69 | (REALTIME OR IMMEDIAT? OR REAL()TIME? OR RIGHT()AWAY OR RI- GHTAWAY OR INSTANT?)(3N) (ORDER? OR PURCHAS? OR BUY?)(3N) (ITE- M? ? OR PRODUCT OR PRODUCTS OR MERCHANDIS?) |
| S5 | 21552 | (ORDER? OR PURCHAS? OR BUY?)(3N) (ITEM? ? OR PRODUCT OR PRO- DUCTS OR MERCHANDIS?) |
| S6 | 566350 | CAR OR CARS OR VEHICLE? OR AUTOMOBILE? |
| S7 | 3728 | (WHILE OR DURING) (3N) (DRIVING OR RIDING) |
| S8 | 0 | (S1 OR S2) (7N)S3(7N)S4 |
| S9 | 0 | (S1 OR S2) (10N)S4 |
| S10 | 0 | S9 NOT PD=>20010913 |
| S11 | 0 | RD (unique items) |
| S12 | 0 | S11 AND S6 |
| S13 | 0 | (S1 OR S2) AND S4 AND S6 |
| S14 | 1 | (S1 OR S2) AND S4 |
| S15 | 3 | (S1 OR S2) AND ORDER?(3N)BUTTON? |
| | | ? |

STIC SEARCH

EIC 3600

Karen Lehman EIC 3600 14-Feb-05

how files;ds

File 635:Business Dateline(R) 1985-2005/Feb 10
(c) 2005 ProQuest Info&Learning
File 570:Gale Group MARS(R) 1984-2005/Feb 14
(c) 2005 The Gale Group
File 387:The Denver Post 1994-2005/Feb 11
(c) 2005 Denver Post
File 471:New York Times Fulltext 1980-2005/Feb 14
(c) 2005 The New York Times
File 492:Arizona Repub/Phoenix Gaz 1986-2002/Jan 06
(c) 2002 Phoenix Newspapers
File 494:St LouisPost-Dispatch 1988-2005/Feb 13
(c) 2005 St Louis Post-Dispatch
File 498:Detroit Free Press 1987-2005/Jan 22
(c) 2005 Detroit Free Press Inc.
File 631:Boston Globe 1980-2005/Feb 11
(c) 2005 Boston Globe
File 633:Phil.Inquirer 1983-2005/Feb 11
(c) 2005 Philadelphia Newspapers Inc
File 638:Newsday/New York Newsday 1987-2005/Feb 13
(c) 2005 Newsday Inc.
File 640:San Francisco Chronicle 1988-2005/Feb 13
(c) 2005 Chronicle Publ. Co.
File 641:Rocky Mountain News Jun 1989-2005/Feb 11
(c) 2005 Scripps Howard News
File 702:Miami Herald 1983-2005/Feb 11
(c) 2005 The Miami Herald Publishing Co.
File 703:USA Today 1989-2005/Feb 12
(c) 2005 USA Today
File 704:(Portland)The Oregonian 1989-2005/Feb 12
(c) 2005 The Oregonian
File 713:Atlanta J/Const. 1989-2005/Jan 30
(c) 2005 Atlanta Newspapers
File 714:(Baltimore) The Sun 1990-2005/Feb 14
(c) 2005 Baltimore Sun
File 715:Christian Sci.Mon. 1989-2005/Feb 14
(c) 2005 Christian Science Monitor
File 725:(Cleveland)Plain Dealer Aug 1991-2005/Feb 10
(c) 2005 The Plain Dealer
File 735:St. Petersburg Times 1989- 2005/Feb 13
(c) 2005 St. Petersburg Times
File 476:Financial Times Fulltext 1982-2005/Feb 14
(c) 2005 Financial Times Ltd
File 477:Irish Times 1999-2005/Feb 13
(c) 2005 Irish Times
File 710:Times/Sun.Times(London) Jun 1988-2005/Feb 14
(c) 2005 Times Newspapers
File 711:Independent(London) Sep 1988-2005/Feb 14
(c) 2005 Newspaper Publ. PLC
File 756:Daily/Sunday Telegraph 2000-2005/Feb 14
(c) 2005 Telegraph Group
File 757:Mirror Publications/Independent Newspapers 2000-2005/Feb 10
(c) 2005

| Set | Items | Description |
|-----|---------|--|
| S1 | 1165722 | RADIO? ? |
| S2 | 7899 | (AM OR FM) ()STATION? |
| S3 | 4505978 | BROADCAST? OR PROGRAM? |
| S4 | 957 | (REALTIME OR IMMEDIAT? OR REAL()TIME? OR RIGHT()AWAY OR RI- GHTAWAY OR INSTANT?)(3N) (ORDER? OR PURCHAS? OR BUY?)(3N)(ITE- M? ? OR PRODUCT OR PRODUCTS OR MERCHANDIS?) |

Karen Lehman EIC 3600 14-Feb-05

Stic Search : EIC 3600

Petitioner Hyundai Ex-1024, 0453

S5 158953 (ORDER? OR PURCHAS? OR BUY?) (3N) (ITEM? ? OR PRODUCT OR PRO-
DUCTS OR MERCHANDIS?)
S6 3042109 CAR OR CARS OR VEHICLE? OR AUTOMOBILE?
S7 78447 (WHILE OR DURING) (3N) (DRIVING OR RIDING)
S8 0 (S1 OR S2) (7N)S3(7N)S4
S9 5 (S1 OR S2) (10N)S4
S10 5 S9 NOT PD=>20010913
S11 5 RD (unique items)
S12 3 S11 AND S6
?

Stic search
EIC 3600

Karen Lehman EIC 3600 14-Feb-05

show files;ds
 File 610:Business Wire 1999-2005/Feb 09
 (c) 2005 Business Wire.
 File 810:Business Wire 1986-1999/Feb 28
 (c) 1999 Business Wire
 File 476:Financial Times Fulltext 1982-2005/Feb 14
 (c) 2005 Financial Times Ltd
 File 624:McGraw-Hill Publications 1985-2005/Feb 14
 (c) 2005 McGraw-Hill Co. Inc
 File 634:San Jose Mercury Jun 1985-2005/Feb 12
 (c) 2005 San Jose Mercury News
 File 20:Dialog Global Reporter 1997-2005/Feb 14
 (c) 2005 The Dialog Corp.

| Set | Items | Description |
|-----|---------|---|
| S1 | 1694556 | RADIO? ? |
| S2 | 5193 | (AM OR FM)()STATION? |
| S3 | 7632054 | BROADCAST? OR PROGRAM? |
| S4 | 3906 | (REALTIME OR IMMEDIAT? OR REAL()TIME? OR RIGHT()AWAY OR RI- GHTAWAY OR INSTANT?)(3N) (ORDER? OR PURCHAS? OR BUY?)(3N) (ITE- M? ? OR PRODUCT OR PRODUCTS OR MERCHANDIS?) |
| S5 | 258168 | (ORDER? OR PURCHAS? OR BUY?)(3N) (ITEM? ? OR PRODUCT OR PRO- DUCTS OR MERCHANDIS?) |
| S6 | 3050384 | CAR OR CARS OR VEHICLE? OR AUTOMOBILE? |
| S7 | 45739 | (WHILE OR DURING) (3N) (DRIVING OR RIDING) |
| S8 | 1 | (S1 OR S2) (7N)S3 (7N)S4 |
| S9 | 8 | (S1 OR S2) (10N)S4 |
| S10 | 4 | S9 NOT PD=>20010913 |
| S11 | 4 | RD (unique items) |
| S12 | 2 | S11 AND S6 |

Stc Search
 EIC 3600

```

show files;ds
File 15:ABI/Inform(R) 1971-2005/Feb 14
      (c) 2005 ProQuest Info&Learning
File  9:Business & Industry(R) Jul/1994-2005/Feb 11
      (c) 2005 The Gale Group
File 275:Gale Group Computer DB(TM) 1983-2005/Feb 14
      (c) 2005 The Gale Group
File 621:Gale Group New Prod.Annou.(R) 1985-2005/Feb 14
      (c) 2005 The Gale Group
File 636:Gale Group Newsletter DB(TM) 1987-2005/Feb 14
      (c) 2005 The Gale Group
File 16:Gale Group PROMT(R) 1990-2005/Feb 14
      (c) 2005 The Gale Group
File 160:Gale Group PROMT(R) 1972-1989
      (c) 1999 The Gale Group
File 148:Gale Group Trade & Industry DB 1976-2005/Feb 11
      (c)2005 The Gale Group

```

| Set | Items | Description |
|-----|---------|---|
| S1 | 1367234 | RADIO? ? |
| S2 | 10747 | (AM OR FM)()STATION? |
| S3 | 8513493 | BROADCAST? OR PROGRAM? |
| S4 | 8453 | (REALTIME OR IMMEDIAT? OR REAL()TIME? OR RIGHT()AWAY OR RI- GHTAWAY OR INSTANT?)(3N) (ORDER? OR PURCHAS? OR BUY?)(3N) (ITE- M? ? OR PRODUCT OR PRODUCTS OR MERCHANDIS?) |
| S5 | 611192 | (ORDER? OR PURCHAS? OR BUY?)(3N) (ITEM? ? OR PRODUCT OR PRO- DUCTS OR MERCHANDIS?) |
| S6 | 2763426 | CAR OR CARS OR VEHICLE? OR AUTOMOBILE? |
| S7 | 29772 | (WHILE OR DURING) (3N) (DRIVING OR RIDING) |
| S8 | 0 | (S1 OR S2)(7N)S3(7N)S4 |
| S9 | 15 | (S1 OR S2)(10N)S4 |
| S10 | 9 | S9 NOT PD=>20010913 |
| S11 | 9 | RD (unique items) |
| S12 | 8 | S11 AND S6 |
| | ? | |

Stic Search
EIC 3600

Knobbe Martens Olson & Bear LLP
Intellectual Property Law

RECEIVED
CENTRAL FAX CENTER
FEB 15 2005

2040 Main Street
Fourteenth Floor
Irvine, CA 92614
Tel 949-760-0404
Fax 949-760-9502
www.kmob.com

FACSIMILE TRANSMITTAL SHEET

CONFIRMATION COPY WILL FOLLOW VIA:

- MAIL
- INTERNATIONAL AIRMAIL
- COURIER
- E-MAIL
- WILL NOT FOLLOW
- HAND DELIVERY
- WITH ENCLOSURES
- WITHOUT ENCLOSURES

Confidentiality Notice:

The documents accompanying this facsimile transmission contain confidential information which may be legally privileged. The information is intended only for the use of the recipient named below. If you have received this facsimile in error, please immediately notify us by telephone to arrange for return of the original documents to us; and any disclosure, copying, distribution or the taking of any action in reliance on the contents of this faxed information is strictly prohibited.

TO: U.S. PATENT & TRADEMARK OFFICE
 FACSIMILE NO.: (703) 872-9306
 OUR REF.: STRATOS.001A
 APP. NO.: 09/953,335
 FILING DATE: September 13, 2001
 FROM: Perry D. Oldham
 OPERATOR: Vicki McCarty NO. OF PAGES: 11 (incl. cover sheet)
 DATE: February 15, 2005 TIME:

IF YOU DID NOT RECEIVE ALL OF THE PAGES PLEASE CALL BACK IMMEDIATELY
 OPERATOR PHONE No.: (949) 760-0404 FACSIMILE No.: (949) 760-9502

MESSAGE: RESPONSE TO NOVEMBER 15, 2004 OFFICE ACTION

PERRY D. OLDHAM
(949) 721-2961

HADOCSPDOFAXESPTO FAX.DOC
112503

San Diego
619-235-8550

San Francisco
415-954-4114

Los Angeles
310-551-3450

Riverside
951-781-9231

San Luis Obispo
805-547-5580

Docket No.: STRATOS.001A

February 15, 2005

Page 1 of 1

Please Direct All Correspondence to Customer Number 20995

AMENDMENT / RESPONSE TRANSMITTAL

Applicant : Christensen et al.
 Appl. No. : 09/953,335
 Filed : September 13, 2001
 For : SYSTEM AND METHOD FOR ORDERING AND DELIVERING MEDIA CONTENT
 Examiner : James Kramer
 Group Art Unit : 3627

CERTIFICATE OF FAX TRANSMISSION
PTO CENTRALIZED FAX

I hereby certify that this correspondence and all marked attachments are being transmitted via facsimile to the USPTO centralized Fax No. (703) 872-9306 on the date shown below:

February 15, 2005

(Date)

Perry D. Oldham
Perry D. Oldham, Reg. No. 52,082

Mail Stop Amendment
Commissioner for Patents
P.O. Box 1450
Alexandria, VA 22313-1450

Sir:

Transmitted herewith for filing in the above-identified application are the following enclosures:

- (X) Response to Office Action in 9 pages.
- (X) The present application qualifies for small entity status under 37 C.F.R. § 1.27.
- (X) Please charge any additional fees, including any fees for additional extension of time, or credit overpayment to Deposit Account No. 11-1410.

Perry D. Oldham
Perry D. Oldham
Registration No. 52,082
Attorney of Record
Customer No. 20,995
(949) 760-0404

H:\DOCS\PDOPDO-2520.DOC
021505

RECEIVED
CENTRAL FAX CENTER

FEB 15 2005

STRATOS.001A

PATENT

IN THE UNITED STATES PATENT AND TRADEMARK OFFICE

Applicant : Kelly-Christensen et al.
 Appl. No. : 09/953,335
 Filed : September 13, 2001
 For : SYSTEM AND METHOD FOR
 ORDERING AND DELIVERING
 MEDIA CONTENT
 Examiner : James A. Kramer
 Group Art Unit : 3627

CERTIFICATE OF FAX TRANSMISSION

I hereby certify that this correspondence and all marked attachments are being transmitted via facsimile to the USPTO Central Fax No. (703) 872-9306 on the date shown below:

February 15, 2005

(Date)

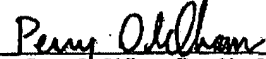

Perry D. Oldham, Reg. No. 52,082

AMENDMENT

Mail Stop Amendment
 Commissioner for Patents
 P.O. Box 1450
 Alexandria, VA 22313-1450

Dear Sir:

In response to a November 15, 2004 Office Action, Applicants respond as follows:

Amendments to the Claims are reflected in the listing of claims which begins on page 2 of this paper.

Remarks/Arguments begin on page 7 of this paper.

Appl. No. : 09/953,335
Filed : September 13, 2001

AMENDMENTS TO THE CLAIMS

1. (canceled)
2. (canceled)
3. (canceled)
4. (canceled)
5. (canceled)
6. (canceled)
7. (canceled)
8. (canceled)
9. (canceled)
10. (canceled)
11. (canceled)
12. (canceled)
13. (canceled)
14. (canceled)
15. (canceled)

16. (withdrawn): A response authentication system for processing requests sent in response to a data stream embedded within a broadcast radio signal, comprising:

a database that contains customer information;

a database that correlates a data stream identifier code with a location of the data stream on a communications network;

a server that correlates the receipt of a request for a specified data stream with information contained in the data stream location database, the request generated by user response to the broadcast radio signal having a program portion and a data portion, said data portion identifying said program portion; and

an order fulfillment server that receives communication of customer information.

17. (withdrawn): The system as in Claim 16, wherein a completed order results in a download of a file corresponding to the specified data stream.

18. (withdrawn): The system of Claim 16, wherein the data stream identifier code is extracted from identification information stored on a compact disc.

Appl. No. : 09/953,335
Filed : September 13, 2001

19. (currently amended): A method of providing a response to a data stream associated with a broadcast channel, comprising, in no particular order:

obtaining information about a scheduled broadcast of at least one audio segment from a broadcaster, the obtained information comprising at least a segment identifier and a specific occurrence of the scheduled broadcast;

~~generating identifying information about the audio segment that is to be transmitted over the broadcast channel;~~

communicating the identifying obtained information and ~~an occurrence of the audio segment broadcast~~ to a database;

using the database to determine a unique reference tag corresponding to at least the segment identifier and the specific occurrence of the identified audio segment scheduled broadcast;

~~determining a broadcast source identifier tag corresponding to a broadcast station;~~

generating a data packet corresponding to at least based on the unique reference tag, a broadcast source identifier and the a database source identifier;

providing the data packet to the broadcaster;

broadcasting the data packet as a first signal stream and the audio segment as a second signal stream;

extracting at a user terminal the data packet from the first signal stream;

generating an audio signal from the second signal stream;

storing in memory at a user terminal data corresponding to the extracted data packet ~~in memory~~, the memory being capable of storing a plurality of entries;

communicating at least one entry from the memory to a user;

displaying the digital data corresponding to the data packet for viewing by a user;

determining a user identifier-tag;

preparing a response packet ~~comprising~~ corresponding to the unique reference tag and the user identifier-tag;

transmitting the response packet to a response authentication system; and

verifying the user identifier-tag.

20. (canceled)

21. (canceled)

Appl. No. : 09/953,335
Filed : September 13, 2001

22. (canceled)

23. (canceled)

24. (canceled)

25. (canceled)

26. (canceled)

27. (canceled)

28. (canceled)

29. (canceled)

30. (canceled)

31. (previously presented): The method of Claim 19, wherein the first signal stream is modulated.

32. (previously presented): The method of Claim 19, wherein the first signal stream is discrete from the second signal stream.

33. (previously presented): The method of Claim 19, wherein the first signal stream is broadcast over a subcarrier channel.

34. (previously presented): The method of Claim 19, wherein the transmitted response packet indicates that the user received the audio segment stream but did not respond.

35. (previously presented): The method of Claim 19, further comprising selecting a communicated entry by user input.

36. (previously presented): The method of Claim 35, wherein the selected entry is chosen from a plurality of communicated entries.

37. (canceled)

38. (previously presented): The method of Claim 19, wherein the unique reference tag corresponds to ~~is based on~~ the broadcaster source.

39. (previously presented): The method of Claim 19, wherein the communicating step identifies a media file available for purchase.

40. (previously presented): The method of Claim 19, further comprising receiving a media file corresponding to the response packet.

41. (previously presented): The method of Claim 40, wherein the media file is received over a wireless network.

Appl. No. : 09/953,335
Filed : September 13, 2001

42. (previously presented): The method of Claim 19, wherein transmitting the response packet comprises storing data on removable media.

43. (previously presented): The method of Claim 19, wherein transmitting the response packet comprises transmitting data over a wireless network.

44. (previously presented): The method of Claim 19, wherein transmitting the response packet comprises transmitting data over a short-length communications cable.

45. (canceled)

Appl. No. : 09/953,335
Filed : September 13, 2001

REMARKS

This communication is responsive to the November 15, 2004 Office Action. With this amendment, Claims 16-19, 31-36, and 38-44 are currently pending, with Claims 16-18 being withdrawn from consideration. Claims 26-30, 37 and 45 are canceled. Claims 19, 34 and 38 are amended. Independent Claim 19, as currently amended, recites limitations not found in the prior art. No new matter is introduced by the current amendments. In view of the foregoing amendments and the following remarks, Applicants respectfully request reconsideration and allowance of this application.

Summary of the Interview

Applicants would like to thank Examiner Kramer and Examiner Cuff for the courtesies extended to Applicants' counsel, William B. Bunker, in a December 17, 2004 interview. In accordance with MPEP § 713.04, a summary of the interview follows. Claim 19 was discussed, and Applicant's counsel presented arguments as to why U.S. Patent 5,438,355 issued to Palmer ("Palmer") does not anticipate or make obvious the claimed invention. The Examiners indicated that, based on the proposed claim language, the claims appear to read over Palmer and are allowable. Substantially similar claim language to the language proposed at the interview is presented herein.

Summary of the Response

In a November 15, 2004 Office Action, Claims 19 and 26-45 were rejected under 35 USC § 103(a) as being unpatentable over Palmer in view of Official Notice. Applicants respectfully traverse the rejection. In an effort to advance the prosecution of the application, Applicants have canceled Claims 26-28 and amended Claim 19. Applicants reserve the right to seek claims in a future application that correspond to the previously pending claims.

Claim 19

Independent Claim 19 was rejected under 35 USC § 103(a) as being unpatentable over Palmer in view of Official Notice. Palmer fails to disclose the combination of limitations recited in amended Claim 19. For example, Claim 19 recites:

Appl. No. : 09/953,335
Filed : September 13, 2001

obtaining information about a scheduled broadcast of at least one audio segment from a broadcaster, the obtained information comprising at least a segment identifier and a specific occurrence of the scheduled broadcast;
communicating the obtained information to a database;
using the database to determine a unique reference tag corresponding to at least the segment identifier and the specific occurrence of the scheduled broadcast;

Palmer discloses program identification codes (PICs) that are, for example, in the form of a vertical interval time code (VITC). See Palmer at 3:5-32. The embedding of vertical interval time codes occurs at the creation of a video segment, and these codes do not change on a real-time basis. Thus, the VITC embodiment disclosed by Palmer is a static system.

In contrast to the claimed invention, Palmer does not disclose obtaining information about a scheduled broadcast of at least one audio segment from a broadcaster, the obtained information comprising at least a segment identifier and a specific occurrence of the scheduled broadcast, communicating the obtained information to a database, and using the database to determine a unique reference tag corresponding to at least the segment identifier and the specific occurrence of the scheduled broadcast.

In certain embodiments, an advertisement or program may be broadcast multiple times, and each broadcast may be given a unique reference tag. Because each broadcast may have its own unique reference tag, multiple broadcasts of the same audio segment can be distinguished. This provides, for example, improved tracking of responses based on individual time slots for the audio segment.

Claim 19, as amended, also recites "*generating a data packet corresponding to at least the unique reference tag, a broadcast identifier and a database identifier.*" An audio segment, such as an advertisement or program, may be broadcast simultaneously on multiple broadcast channels in accordance with certain embodiments. Including information about the broadcast source in the data packet allows for distinguishing between sources, even if the audio segment is the same. In other embodiments, the possibility also exists that individual broadcasters may use different databases for storing information about the unique reference tag. Including information about the database source allows for identifying the correct database to use. Palmer, in contrast,

Appl. No. : 09/953,335
Filed : September 13, 2001

does not disclose *generating a data packet corresponding to at least the unique reference tag, a broadcast identifier and a database identifier.*

Independent Claim 19 further recites:

*storing in memory at a user terminal data corresponding to the extracted data packet, the memory being capable of storing a plurality of entries;
communicating at least one entry from the memory to a user;*

Palmer, in contrast, does not disclose or suggest storing in memory at a user terminal data corresponding to the extracted data packet, the memory being capable of storing a plurality of entries, and communicating at least one entry from the memory to a user. The VCR function identified by the Examiner does not store an extracted data packet. Instead, the VCR stores the raw data stream from the broadcast.

Claim 19 additionally recites "*determining a user identifier.*" Although Palmer discloses console identification codes (CIC), Palmer does not disclose determining a user identifier. Console information, such as a device serial number, is not the same as user information. Advantageously, transmitting the user identifier as claimed allows multiple users to use a single device. In contrast, the console identification code disclosed by Palmer does not provide any way to distinguish between multiple users of a single console.

These and other limitations recited in Claim 19 demonstrate the patentability of the claim, and allowance is respectfully requested.

Although the response has focused on independent Claim 19, each of the dependent claims also recites additional limitations that are patentable over the cited art.

Conclusion

Applicants have endeavored to address all of the Examiner's concerns as expressed in the outstanding Office Action. In view of the foregoing amendments and remarks, Applicants submit that the claims are patentably distinct from the cited art. Applicants respectfully submit

Appl. No. : 09/953,335
Filed : September 13, 2001

that the claims are in condition for allowance. Furthermore, any remarks in support of patentability of one claim should not be imputed to any other claim, even if similar terminology is used. Any remarks referring to only a portion of a claim should not be understood to base patentability on that portion; rather, patentability must rest on each claim taken as a whole. Although changes to the claims have been made, no acquiescence or estoppel is or should be implied thereby; such amendments are made only to expedite prosecution of the present application and are without prejudice to the presentation or assertion, in the future, of claims relating to the same or similar subject matter.

If the Examiner finds any remaining impediment to the prompt allowance of these claims that could be clarified with a telephone conference, the Examiner is respectfully requested to initiate the same with the undersigned attorney of record at his direct dial number of (949) 721-2961.

Please charge any additional fees, including any fees for additional extension of time, or credit overpayment to Deposit Account No. 11-1410.

Respectfully submitted,

KNOBBE, MARTENS, OLSON & BEAR, LLP

Dated: 2/15/2005

By: Perry Oldham
Perry D. Oldham
Registration No. 52,082
Attorney of Record
Customer No. 20,995
(949) 760-0404

2005-02-15 AMENDMENT.DOC
021505



UNITED STATES PATENT AND TRADEMARK OFFICE

UNITED STATES DEPARTMENT OF COMMERCE
United States Patent and Trademark Office
Address: COMMISSIONER FOR PATENTS
P.O. Box 1450
Alexandria, Virginia 22313-1450
www.uspto.gov

NOTICE OF ALLOWANCE AND FEE(S) DUE

20995 7590 05/06/2005
KNOBBE MARTENS OLSON & BEAR LLP
2040 MAIN STREET
FOURTEENTH FLOOR
IRVINE, CA 92614

EXAMINER: KRAMER, JAMES A
ART UNIT: 3627 PAPER NUMBER:
DATE MAILED: 05/06/2005

Table with 5 columns: APPLICATION NO., FILING DATE, FIRST NAMED INVENTOR, ATTORNEY DOCKET NO., CONFIRMATION NO.

TITLE OF INVENTION: SYSTEM AND METHOD FOR ORDERING AND DELIVERING MEDIA CONTENT

Table with 6 columns: APPLN. TYPE, SMALL ENTITY, ISSUE FEE, PUBLICATION FEE, TOTAL FEE(S) DUE, DATE DUE

THE APPLICATION IDENTIFIED ABOVE HAS BEEN EXAMINED AND IS ALLOWED FOR ISSUANCE AS A PATENT. PROSECUTION ON THE MERITS IS CLOSED. THIS NOTICE OF ALLOWANCE IS NOT A GRANT OF PATENT RIGHTS. THIS APPLICATION IS SUBJECT TO WITHDRAWAL FROM ISSUE AT THE INITIATIVE OF THE OFFICE OR UPON PETITION BY THE APPLICANT. SEE 37 CFR 1.313 AND MPEP 1308.

THE ISSUE FEE AND PUBLICATION FEE (IF REQUIRED) MUST BE PAID WITHIN THREE MONTHS FROM THE MAILING DATE OF THIS NOTICE OR THIS APPLICATION SHALL BE REGARDED AS ABANDONED. THIS STATUTORY PERIOD CANNOT BE EXTENDED. SEE 35 U.S.C. 151. THE ISSUE FEE DUE INDICATED ABOVE REFLECTS A CREDIT FOR ANY PREVIOUSLY PAID ISSUE FEE APPLIED IN THIS APPLICATION. THE PTOL-85B (OR AN EQUIVALENT) MUST BE RETURNED WITHIN THIS PERIOD EVEN IF NO FEE IS DUE OR THE APPLICATION WILL BE REGARDED AS ABANDONED.

HOW TO REPLY TO THIS NOTICE:

I. Review the SMALL ENTITY status shown above.

If the SMALL ENTITY is shown as YES, verify your current SMALL ENTITY status:

- A. If the status is the same, pay the TOTAL FEE(S) DUE shown above.
B. If the status above is to be removed, check box 5b on Part B - Fee(s) Transmittal and pay the PUBLICATION FEE (if required) and twice the amount of the ISSUE FEE shown above, or

If the SMALL ENTITY is shown as NO:

- A. Pay TOTAL FEE(S) DUE shown above, or
B. If applicant claimed SMALL ENTITY status before, or is now claiming SMALL ENTITY status, check box 5a on Part B - Fee(s) Transmittal and pay the PUBLICATION FEE (if required) and 1/2 the ISSUE FEE shown above.

II. PART B - FEE(S) TRANSMITTAL should be completed and returned to the United States Patent and Trademark Office (USPTO) with your ISSUE FEE and PUBLICATION FEE (if required). Even if the fee(s) have already been paid, Part B - Fee(s) Transmittal should be completed and returned. If you are charging the fee(s) to your deposit account, section "4b" of Part B - Fee(s) Transmittal should be completed and an extra copy of the form should be submitted.

III. All communications regarding this application must give the application number. Please direct all communications prior to issuance to Mail Stop ISSUE FEE unless advised to the contrary.

IMPORTANT REMINDER: Utility patents issuing on applications filed on or after Dec. 12, 1980 may require payment of maintenance fees. It is patentee's responsibility to ensure timely payment of maintenance fees when due.

PART B - FEE(S) TRANSMITTAL

Complete and send this form, together with applicable fee(s), to: **Mail** **Mail Stop ISSUE FEE**
Commissioner for Patents
P.O. Box 1450
Alexandria, Virginia 22313-1450
or Fax (703) 746-4000

INSTRUCTIONS: This form should be used for transmitting the ISSUE FEE and PUBLICATION FEE (if required). Blocks 1 through 5 should be completed where appropriate. All further correspondence including the Patent, advance orders and notification of maintenance fees will be mailed to the current correspondence address as indicated unless corrected below or directed otherwise in Block 1, by (a) specifying a new correspondence address; and/or (b) indicating a separate "FEE ADDRESS" for maintenance fee notifications.

CURRENT CORRESPONDENCE ADDRESS (Note: Use Block 1 for any change of address)

20995 7590 05/06/2005

KNOBBE MARTENS OLSON & BEAR LLP
2040 MAIN STREET
FOURTEENTH FLOOR
IRVINE, CA 92614

Note: A certificate of mailing can only be used for domestic mailings of the Fee(s) Transmittal. This certificate cannot be used for any other accompanying papers. Each additional paper, such as an assignment or formal drawing, must have its own certificate of mailing or transmission.

Certificate of Mailing or Transmission

I hereby certify that this Fee(s) Transmittal is being deposited with the United States Postal Service with sufficient postage for first class mail in an envelope addressed to the Mail Stop ISSUE FEE address above, or being facsimile transmitted to the USPTO (703) 746-4000, on the date indicated below.

| |
|--------------------|
| (Depositor's name) |
| (Signature) |
| (Date) |

| APPLICATION NO. | FILING DATE | FIRST NAMED INVENTOR | ATTORNEY DOCKET NO. | CONFIRMATION NO. |
|-----------------|-------------|----------------------|---------------------|------------------|
| 09/953,335 | 09/13/2001 | Kelly M. Christensen | STRATOS.001A | 4917 |

TITLE OF INVENTION: SYSTEM AND METHOD FOR ORDERING AND DELIVERING MEDIA CONTENT

| APPLN. TYPE | SMALL ENTITY | ISSUE FEE | PUBLICATION FEE | TOTAL FEE(S) DUE | DATE DUE |
|----------------|--------------|-----------|-----------------|------------------|------------|
| nonprovisional | NO | \$1400 | \$300 | \$1700 | 08/08/2005 |

| EXAMINER | ART UNIT | CLASS-SUBCLASS |
|-----------------|----------|----------------|
| KRAMER, JAMES A | 3627 | 705-027000 |

1. Change of correspondence address or indication of "Fee Address" (37 CFR 1.363).
 Change of correspondence address (or Change of Correspondence Address form PTO/SB/122) attached.
 "Fee Address" indication (or "Fee Address" Indication form PTO/SB/47; Rev 03-02 or more recent) attached. Use of a Customer Number is required.

2. For printing on the patent front page, list
 (1) the names of up to 3 registered patent attorneys or agents OR, alternatively,
 (2) the name of a single firm (having as a member a registered attorney or agent) and the names of up to 2 registered patent attorneys or agents. If no name is listed, no name will be printed.

1 _____
 2 _____
 3 _____

3. ASSIGNEE NAME AND RESIDENCE DATA TO BE PRINTED ON THE PATENT (print or type)

PLEASE NOTE: Unless an assignee is identified below, no assignee data will appear on the patent. If an assignee is identified below, the document has been filed for recordation as set forth in 37 CFR 3.11. Completion of this form is NOT a substitute for filing an assignment.

(A) NAME OF ASSIGNEE _____ (B) RESIDENCE: (CITY and STATE OR COUNTRY) _____

Please check the appropriate assignee category or categories (will not be printed on the patent) : Individual Corporation or other private group entity Government

4a. The following fee(s) are enclosed:

- Issue Fee
- Publication Fee (No small entity discount permitted)
- Advance Order - # of Copies _____

4b. Payment of Fee(s):

- A check in the amount of the fee(s) is enclosed.
- Payment by credit card. Form PTO-2038 is attached.
- The Director is hereby authorized by charge the required fee(s), or credit any overpayment, to Deposit Account Number _____ (enclose an extra copy of this form).

5. Change in Entity Status (from status indicated above)

- a. Applicant claims SMALL ENTITY status. See 37 CFR 1.27.
- b. Applicant is no longer claiming SMALL ENTITY status. See 37 CFR 1.27(g)(2).

The Director of the USPTO is requested to apply the Issue Fee and Publication Fee (if any) or to re-apply any previously paid issue fee to the application identified above.

NOTE: The Issue Fee and Publication Fee (if required) will not be accepted from anyone other than the applicant; a registered attorney or agent; or the assignee or other party in interest as shown by the records of the United States Patent and Trademark Office.

Authorized Signature _____

Date _____

Typed or printed name _____

Registration No. _____

This collection of information is required by 37 CFR 1.311. The information is required to obtain or retain a benefit by the public which is to file (and by the USPTO to process) an application. Confidentiality is governed by 35 U.S.C. 122 and 37 CFR 1.14. This collection is estimated to take 12 minutes to complete, including gathering, preparing, and submitting the completed application form to the USPTO. Time will vary depending upon the individual case. Any comments on the amount of time you require to complete this form and/or suggestions for reducing this burden, should be sent to the Chief Information Officer, U.S. Patent and Trademark Office, U.S. Department of Commerce, P.O. Box 1450, Alexandria, Virginia 22313-1450. DO NOT SEND FEES OR COMPLETED FORMS TO THIS ADDRESS. SEND TO: Commissioner for Patents, P.O. Box 1450, Alexandria, Virginia 22313-1450.

Under the Paperwork Reduction Act of 1995, no persons are required to respond to a collection of information unless it displays a valid OMB control number.



UNITED STATES PATENT AND TRADEMARK OFFICE

UNITED STATES DEPARTMENT OF COMMERCE
United States Patent and Trademark Office
Address: COMMISSIONER FOR PATENTS
P.O. Box 1450
Alexandria, Virginia 22313-1450
www.uspto.gov

Table with 5 columns: APPLICATION NO., FILING DATE, FIRST NAMED INVENTOR, ATTORNEY DOCKET NO., CONFIRMATION NO.
09/953,335 09/13/2001 Kelly M. Christensen STRATOS.001A 4917

20995 7590 05/06/2005
KNOBBE MARTENS OLSON & BEAR LLP
2040 MAIN STREET
FOURTEENTH FLOOR
IRVINE, CA 92614

EXAMINER

KRAMER, JAMES A

ART UNIT PAPER NUMBER

3627

DATE MAILED: 05/06/2005

Determination of Patent Term Adjustment under 35 U.S.C. 154 (b)
(application filed on or after May 29, 2000)

The Patent Term Adjustment to date is 69 day(s). If the issue fee is paid on the date that is three months after the mailing date of this notice and the patent issues on the Tuesday before the date that is 28 weeks (six and a half months) after the mailing date of this notice, the Patent Term Adjustment will be 69 day(s).

If a Continued Prosecution Application (CPA) was filed in the above-identified application, the filing date that determines Patent Term Adjustment is the filing date of the most recent CPA.

Applicant will be able to obtain more detailed information by accessing the Patent Application Information Retrieval (PAIR) WEB site (http://pair.uspto.gov).

Any questions regarding the Patent Term Extension or Adjustment determination should be directed to the Office of Patent Legal Administration at (571) 272-7702. Questions relating to issue and publication fee payments should be directed to the Customer Service Center of the Office of Patent Publication at (703) 305-8283.

| | | | |
|-------------------------------|------------------------|---------------------|--|
| Notice of Allowability | Application No. | Applicant(s) | |
| | 09/953,335 | CHRISTENSEN ET AL. | |
| | Examiner | Art Unit | |
| | James A. Kramer | 3627 | |

-- The MAILING DATE of this communication appears on the cover sheet with the correspondence address--

All claims being allowable, PROSECUTION ON THE MERITS IS (OR REMAINS) CLOSED in this application. If not included herewith (or previously mailed), a Notice of Allowance (PTOL-85) or other appropriate communication will be mailed in due course. **THIS NOTICE OF ALLOWABILITY IS NOT A GRANT OF PATENT RIGHTS.** This application is subject to withdrawal from issue at the initiative of the Office or upon petition by the applicant. See 37 CFR 1.313 and MPEP 1308.

1. This communication is responsive to amendment filed 2/15/05.
2. The allowed claim(s) is/are 19, 31-36 & 38-44 JAS
3. The drawings filed on 07 January 2002 are accepted by the Examiner.
4. Acknowledgment is made of a claim for foreign priority under 35 U.S.C. § 119(a)-(d) or (f).
 - a) All b) Some* c) None of the:
 1. Certified copies of the priority documents have been received.
 2. Certified copies of the priority documents have been received in Application No. _____.
 3. Copies of the certified copies of the priority documents have been received in this national stage application from the International Bureau (PCT Rule 17.2(a)).

* Certified copies not received: _____.

Applicant has THREE MONTHS FROM THE "MAILING DATE" of this communication to file a reply complying with the requirements noted below. Failure to timely comply will result in ABANDONMENT of this application.
THIS THREE-MONTH PERIOD IS NOT EXTENDABLE.

5. A SUBSTITUTE OATH OR DECLARATION must be submitted. Note the attached EXAMINER'S AMENDMENT or NOTICE OF INFORMAL PATENT APPLICATION (PTO-152) which gives reason(s) why the oath or declaration is deficient.
6. CORRECTED DRAWINGS (as "replacement sheets") must be submitted.
 - (a) including changes required by the Notice of Draftsperson's Patent Drawing Review (PTO-948) attached
 - 1) hereto or 2) to Paper No./Mail Date _____.
 - (b) including changes required by the attached Examiner's Amendment / Comment or in the Office action of Paper No./Mail Date _____.

Identifying indicia such as the application number (see 37 CFR 1.84(c)) should be written on the drawings in the front (not the back) of each sheet. Replacement sheet(s) should be labeled as such in the header according to 37 CFR 1.121(d).
7. DEPOSIT OF and/or INFORMATION about the deposit of BIOLOGICAL MATERIAL must be submitted. Note the attached Examiner's comment regarding REQUIREMENT FOR THE DEPOSIT OF BIOLOGICAL MATERIAL.

Attachment(s)

- | | |
|--|--|
| 1. <input type="checkbox"/> Notice of References Cited (PTO-892) | 5. <input type="checkbox"/> Notice of Informal Patent Application (PTO-152) |
| 2. <input type="checkbox"/> Notice of Draftsperson's Patent Drawing Review (PTO-948) | 6. <input type="checkbox"/> Interview Summary (PTO-413), Paper No./Mail Date _____. |
| 3. <input checked="" type="checkbox"/> Information Disclosure Statements (PTO-1449 or PTO/SB/08), Paper No./Mail Date _____ | 7. <input checked="" type="checkbox"/> Examiner's Amendment/Comment |
| 4. <input type="checkbox"/> Examiner's Comment Regarding Requirement for Deposit of Biological Material | 8. <input checked="" type="checkbox"/> Examiner's Statement of Reasons for Allowance |
| | 9. <input type="checkbox"/> Other _____. |

Art Unit: 3627

DETAILED ACTION

EXAMINER'S AMENDMENT

An examiner's amendment to the record appears below. Should the changes and/or additions be unacceptable to applicant, an amendment may be filed as provided by 37 CFR 1.312. To ensure consideration of such an amendment, it MUST be submitted no later than the payment of the issue fee.

The application has been amended as follows: Claims 16, 17 and 18 are hereby cancelled. These claims are drawn on a non-elected invention. In addition, the restriction was made without traverse during a phone call with Perry Oldham on 6/6/03 and documented in the Office Action mailed 6/27/03.

REASONS FOR ALLOWANCE

The following is an examiner's statement of reasons for allowance:

Palmer (U.S. Patent Number 5,438,355) represents the closest U.S. Patent art of record. The present invention stands patentable over Palmer because the data packet sent with the audio stream of the present invention includes information related to the specific occurrence of the broadcast.

Palmer et al. teaches embedding the program identification codes (PIC) in the form of vertical interval time codes (VITC). The program identification codes of Palmer et al. identify the unique program broadcasted but fail to indicate the specific occurrence of the broadcast.

Art Unit: 3627

Further, the embedding of the PICs in the VITCs of the video segment occurs at the creation of the video segment. Since it is impossible to know each and every scheduled broadcast of the video segment at the time of its creation, there is no way that the PIC codes of Palmer et al. could include an identification of the specific occurrences of the scheduled broadcast.

In contrast Applicant's invention attaches the data packet (program identification codes) as an additional signal stream broadcast with the audio stream. Since the additional signal stream has no relation to the generation of the audio segment and is attached just prior to broadcast, the present invention allows for the inclusion of information that identifies the specific occurrence of the broadcast.

As such, Palmer et al. teaches away from the present invention. And thus, not only does Palmer et al. fail to anticipate the present invention but Palmer et al. also fails to render it obvious.

"Sirius to Add 'Instant Buy' Button" is the closest NPL art of record. The present invention is allowable over "Sirius to Add 'Instant Buy' Button" because the reference fails to detail any specifics on the broadcast data stream.

Art Unit: 3627

EP 0 713 335 A2 represents the closest Foreign art of record (Examiner notes that this reference was submitted by Applicant in the IDS filed 12/1/03). The present invention is allowable over EP 0 713 335 A2 because the reference fails to disclose information related to the specific occurrence of the broadcast. The reference teaches indiscernible data may be information needed to order services or product, including price, delivery intervals, shipping details and coupon offers. Examiner notes that the specific occurrence of the broadcast is not required to order the product and thus is not anticipated nor made obvious by this reference.

CONCLUSION

Any comments considered necessary by applicant must be submitted no later than the payment of the issue fee and, to avoid processing delays, should preferably accompany the issue fee. Such submissions should be clearly labeled "Comments on Statement of Reasons for Allowance."

Any inquiry concerning this communication or earlier communications from the examiner should be directed to James A. Kramer whose telephone number is (571) 272 6783. The examiner can normally be reached on Monday - Friday (8AM - 5PM).

If attempts to reach the examiner by telephone are unsuccessful, the examiner's supervisor, Richard Chilcot can be reached on (571) 272 6777. The fax phone number for the organization where this application or proceeding is assigned is 703-872-9306.

Art Unit: 3627

Information regarding the status of an application may be obtained from the Patent Application Information Retrieval (PAIR) system. Status information for published applications may be obtained from either Private PAIR or Public PAIR. Status information for unpublished applications is available through Private PAIR only. For more information about the PAIR system, see <http://pair-direct.uspto.gov>. Should you have questions on access to the Private PAIR system, contact the Electronic Business Center (EBC) at 866-217-9197 (toll-free).

James A. Kramer
Examiner
Art Unit 3627

JAK

 4/21/05
ROBERT P. OLSZEWSKI
SUPERVISORY PATENT EXAMINER
TECHNOLOGY CENTER 3600

| | | |
|---|-----------------------------------|-------------------------------|
| FORM PTO-1449 U.S. DEPARTMENT OF COMMERCE PATENT AND TRADEMARK OFFICE INFORMATION DISCLOSURE STATEMENT BY APPLICANT (USE SEVERAL SHEETS IF NECESSARY) | ATTY. DOCKET NO. STRATOS.001A | APPLICATION NO. 09/953,335 |
| | APPLICANT Christensen et al | |
| | FILING DATE September 13, 2001 | GROUP 3627 |

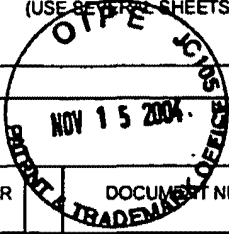

| U.S. PATENT DOCUMENTS | | | | | | | |
|-----------------------|-----------------|-----------------|---------|-----------------|----------|------------------------------|--|
| EXAMINER INITIAL | DOCUMENT NUMBER | DATE | NAME | CLASS | SUBCLASS | FILING DATE (IF APPROPRIATE) | |
| JH | 1 | 2003/0097338 A1 | 5/22/03 | Mankovich et al | | | |
| | | | | | | | |
| | | | | | | | |

| EXAMINER INITIAL | OTHER DOCUMENTS (INCLUDING AUTHOR, TITLE, DATE, PERTINENT PAGES, ETC.) | |
|------------------|--|---|
| JM | 2 | U.S. Patent Appl No. 10/806,084, filed March 22, 2004; Preliminary Amendment filed on 7/21/04 |
| | | 3/21/03 |
| | | |
| | | |

H:\DOCS\PDO\PDO-2434.DOC
111004

| | | | |
|--|--|-----------------|---------|
| EXAMINER | | DATE CONSIDERED | 4/20/05 |
| *EXAMINER: INITIAL IF CITATION CONSIDERED, WHETHER OR NOT CITATION IS IN CONFORMANCE WITH MPEP 609; DRAW LINE THROUGH CITATION IF NOT IN CONFORMANCE AND NOT CONSIDERED. INCLUDE COPY OF THIS FORM WITH NEXT COMMUNICATION TO APPLICANT. | | | |

| | | |
|--|--|-------------------------------|
| FORM PTO-1449 U.S. DEPARTMENT OF COMMERCE PATENT AND TRADEMARK OFFICE INFORMATION DISCLOSURE STATEMENT BY APPLICANT (USE SEVERAL SHEETS IF NECESSARY) | ATTY. DOCKET NO. STRATOS.001A | APPLICATION NO. 09/853,335 |
| | APPLICANT Kelly M. Christensen, et al | |
| | FILING DATE September 13, 2001 | GROUP 3827 |

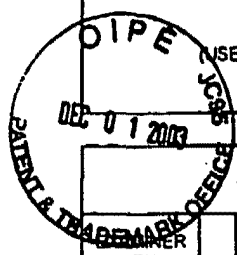

| U.S. PATENT DOCUMENTS | | | | | | |
|-----------------------|-----------------|----------------|---------|----------------|----------|------------------------------|
| EXAMINER INITIAL | DOCUMENT NUMBER | DATE | NAME | CLASS | SUBCLASS | FILING DATE (IF APPROPRIATE) |
| | 1. | US2003/0097338 | 5/22/03 | Manovich et al | | |

| FOREIGN PATENT DOCUMENTS | | | | | | | | |
|--------------------------|-----------------|------------------|---------|--------------------|----------|-------------|----|--|
| EXAMINER INITIAL | DOCUMENT NUMBER | DATE | COUNTRY | CLASS | SUBCLASS | TRANSLATION | | |
| | | | | | | YES | NO | |
| me | 2 | PCT/GB92/00181 | 8/20/92 | Tait et al | | | | |
| | 3 | PCT/GB93/01526 | 2/3/94 | Tait et al | | | | |
| | 4 | PCT/CA96/00794 | 6/12/97 | Michael Pocock | | | | |
| | 5 | PCT/FI97/00315 | 12/4/97 | Behruz Vazvan | | | | |
| | 6 | PCT/US00/17157 | 1/4/01 | Davis et al | | | | |
| | 7 | PCT/US01/02781 | 8/9/01 | S. Jeffrey | | | | |
| | 8 | EP 0 713 335 A2 | 5/22/96 | August et al | | | | |
| | 9 | DE 44 27 046 A1 | 2/1/96 | Goldscheider et al | | | | |
| | 10 | DE 196 27 308 A1 | 1/2/98 | Dr. Peter Mihatsch | | | | |
| | 11 | 10-135855 | 5/22/98 | Japanese Patent | | | | |

RECEIVED
 DEC 01 2003
 GROUP 3800

| EXAMINER INITIAL | OTHER DOCUMENTS (INCLUDING AUTHOR, TITLE, DATE, PERTINENT PAGES, ETC.) |
|------------------|---|
| JSA | 12 "Bookmark Your World", 1999- 2000 Xenote, www.xenote.com |
| JW | 13 1/25/00, Showcase 2000 - Xenote Press Release re Xenote iTag, www.xenote.com/html/press/releases.html |
| | 14 |
| | 15 |
| | 16 |

H:\DOCS\PD\IPDO-2211.DOC
 111003

| | |
|--|-------------------------|
| EXAMINER | DATE CONSIDERED 4/20/05 |
| *EXAMINER: INITIAL IF CITATION CONSIDERED. WHETHER OR NOT CITATION IS IN CONFORMANCE WITH MPEP 609; DRAW LINE THROUGH CITATION IF NOT IN CONFORMANCE AND NOT CONSIDERED, INCLUDE COPY OF THIS FORM WITH NEXT COMMUNICATION TO APPLICANT. | |

| | | | |
|-----------------------------------|---------------------------------------|---|-------------|
| Notice of References Cited | Application/Control No. 09/953,335 | Applicant(s)/Patent Under Reexamination CHRISTENSEN ET AL. | |
| | Examiner James A. Kramer | Art Unit 3627 | Page 1 of 1 |

U.S. PATENT DOCUMENTS

| * | Document Number Country Code-Number-Kind Code | Date MM-YYYY | Name | Classification |
|---|--|-----------------|------|----------------|
| | A US- | | | |
| | B US- | | | |
| | C US- | | | |
| | D US- | | | |
| | E US- | | | |
| | F US- | | | |
| | G US- | | | |
| | H US- | | | |
| | I US- | | | |
| | J US- | | | |
| | K US- | | | |
| | L US- | | | |
| | M US- | | | |

FOREIGN PATENT DOCUMENTS

| * | Document Number Country Code-Number-Kind Code | Date MM-YYYY | Country | Name | Classification |
|---|--|-----------------|---------|------|----------------|
| | N | | | | |
| | O | | | | |
| | P | | | | |
| | Q | | | | |
| | R | | | | |
| | S | | | | |
| | T | | | | |

NON-PATENT DOCUMENTS

| * | Include as applicable: Author, Title Date, Publisher, Edition or Volume, Pertinent Pages) |
|---|---|
| U | "Sirius to Add 'Instant Buy' Button", March 13, 2000, Twice, V15, n 7, p 28 |
| V | |
| W | |
| X | |

*A copy of this reference is not being furnished with this Office action. (See MPEP § 707.05(a).)
Dates in MM-YYYY format are publication dates. Classifications may be US or foreign.

| | | | |
|--|--------------------------------------|---|--|
| Issue Classification  | Application No. 09/953,335 | Applicant(s) CHRISTENSEN ET AL. | |
| | Examiner James A. Kramer | Art Unit 3627 | |

I-6
4/20/05
JEAN
Gelin
Au
2681

| ISSUE CLASSIFICATION | | | | | | | | | |
|-------------------------------------|----------|-------|-----------------------------------|--|--|--|--|--|--|
| ORIGINAL | | | CROSS REFERENCE(S) | | | | | | |
| CLASS | SUBCLASS | CLASS | SUBCLASS (ONE SUBCLASS PER BLOCK) | | | | | | |
| 455 | 3.06 | 705 | 26 | | | | | | |
| INTERNATIONAL CLASSIFICATION | | | | | | | | | |
| H 0 4 H | 7 1 0 0 | | | | | | | | |
| | / | | | | | | | | |
| | / | | | | | | | | |
| | / | | | | | | | | |
| | / | | | | | | | | |

| | | |
|---|---|---|
| <i>Jan A. Kramer</i> (Assistant Examiner) 4/21/05 (Date) | <i>Robert P. Olszewski</i> ROBERT P. OLSZEWSKI SUPERVISORY PATENT EXAMINER TECHNOLOGY CENTER 3600 (Primary Examiner) 4/21/05 (Date) | Total Claims Allowed: 14 O.G. Print Claim(s): 1 O.G. Print Fig.: 1A |
|---|---|---|

| <input type="checkbox"/> Claims renumbered in the same order as presented by applicant | | <input type="checkbox"/> CPA | | <input type="checkbox"/> T.D. | | <input type="checkbox"/> R.1.47 | |
|--|----------|------------------------------|----------|-------------------------------|----------|---------------------------------|----------|
| Final | Original | Final | Original | Final | Original | Final | Original |
| | 1 | 2 | 31 | | 61 | | 91 |
| | 2 | 3 | 32 | | 62 | | 92 |
| | 3 | 4 | 33 | | 63 | | 93 |
| | 4 | 5 | 34 | | 64 | | 94 |
| | 5 | 6 | 35 | | 65 | | 95 |
| | 6 | 7 | 36 | | 66 | | 96 |
| | 7 | | 37 | | 67 | | 97 |
| | 8 | 8 | 38 | | 68 | | 98 |
| | 9 | 9 | 39 | | 69 | | 99 |
| | 10 | 10 | 40 | | 70 | | 100 |
| | 11 | 11 | 41 | | 71 | | 101 |
| | 12 | 12 | 42 | | 72 | | 102 |
| | 13 | 13 | 43 | | 73 | | 103 |
| | 14 | 14 | 44 | | 74 | | 104 |
| | 15 | | 45 | | 75 | | 105 |
| | 16 | | 46 | | 76 | | 106 |
| | 17 | | 47 | | 77 | | 107 |
| | 18 | | 48 | | 78 | | 108 |
| 1 | 19 | | 49 | | 79 | | 109 |
| | 20 | | 50 | | 80 | | 110 |
| | 21 | | 51 | | 81 | | 111 |
| | 22 | | 52 | | 82 | | 112 |
| | 23 | | 53 | | 83 | | 113 |
| | 24 | | 54 | | 84 | | 114 |
| | 25 | | 55 | | 85 | | 115 |
| | 26 | | 56 | | 86 | | 116 |
| | 27 | | 57 | | 87 | | 117 |
| | 28 | | 58 | | 88 | | 118 |
| | 29 | | 59 | | 89 | | 119 |
| | 30 | | 60 | | 90 | | 120 |
| | | | | | | | 121 |
| | | | | | | | 122 |
| | | | | | | | 123 |
| | | | | | | | 124 |
| | | | | | | | 125 |
| | | | | | | | 126 |
| | | | | | | | 127 |
| | | | | | | | 128 |
| | | | | | | | 129 |
| | | | | | | | 130 |
| | | | | | | | 131 |
| | | | | | | | 132 |
| | | | | | | | 133 |
| | | | | | | | 134 |
| | | | | | | | 135 |
| | | | | | | | 136 |
| | | | | | | | 137 |
| | | | | | | | 138 |
| | | | | | | | 139 |
| | | | | | | | 140 |
| | | | | | | | 141 |
| | | | | | | | 142 |
| | | | | | | | 143 |
| | | | | | | | 144 |
| | | | | | | | 145 |
| | | | | | | | 146 |
| | | | | | | | 147 |
| | | | | | | | 148 |
| | | | | | | | 149 |
| | | | | | | | 150 |
| | | | | | | | 151 |
| | | | | | | | 152 |
| | | | | | | | 153 |
| | | | | | | | 154 |
| | | | | | | | 155 |
| | | | | | | | 156 |
| | | | | | | | 157 |
| | | | | | | | 158 |
| | | | | | | | 159 |
| | | | | | | | 160 |
| | | | | | | | 161 |
| | | | | | | | 162 |
| | | | | | | | 163 |
| | | | | | | | 164 |
| | | | | | | | 165 |
| | | | | | | | 166 |
| | | | | | | | 167 |
| | | | | | | | 168 |
| | | | | | | | 169 |
| | | | | | | | 170 |
| | | | | | | | 171 |
| | | | | | | | 172 |
| | | | | | | | 173 |
| | | | | | | | 174 |
| | | | | | | | 175 |
| | | | | | | | 176 |
| | | | | | | | 177 |
| | | | | | | | 178 |
| | | | | | | | 179 |
| | | | | | | | 180 |
| | | | | | | | 181 |
| | | | | | | | 182 |
| | | | | | | | 183 |
| | | | | | | | 184 |
| | | | | | | | 185 |
| | | | | | | | 186 |
| | | | | | | | 187 |
| | | | | | | | 188 |
| | | | | | | | 189 |
| | | | | | | | 190 |
| | | | | | | | 191 |
| | | | | | | | 192 |
| | | | | | | | 193 |
| | | | | | | | 194 |
| | | | | | | | 195 |
| | | | | | | | 196 |
| | | | | | | | 197 |
| | | | | | | | 198 |
| | | | | | | | 199 |
| | | | | | | | 200 |
| | | | | | | | 201 |
| | | | | | | | 202 |
| | | | | | | | 203 |
| | | | | | | | 204 |
| | | | | | | | 205 |
| | | | | | | | 206 |
| | | | | | | | 207 |
| | | | | | | | 208 |
| | | | | | | | 209 |
| | | | | | | | 210 |



UNITED STATES PATENT AND TRADEMARK OFFICE

COMMISSIONER FOR PATENTS
 UNITED STATES PATENT AND TRADEMARK OFFICE
 WASHINGTON, D.C. 20231
 www.uspto.gov



Bib Data Sheet

CONFIRMATION NO. 4917

| | | | | |
|------------------------------------|---|---------------------|-------------------------------|--|
| SERIAL NUMBER 09/953,335 | FILING DATE 09/13/2001 RULE | CLASS 455 | GROUP ART UNIT 2681 | ATTORNEY DOCKET NO. STRATOS.001A |
|------------------------------------|---|---------------------|-------------------------------|--|

APPLICANTS
 Kelly M. Christensen, Alhambra, CA;
 Barry D. Thomas, West Hills, CA;
 Thomas J. Smyth, North Hollywood, CA;

**** CONTINUING DATA *******
 THIS APPLN CLAIMS BENEFIT OF 60/292,333 09/13/2000 *JAC 4/26/05*

**** FOREIGN APPLICATIONS *******

IF REQUIRED, FOREIGN FILING LICENSE GRANTED
**** 10/12/2001**

| | | | | |
|---|------------------------|---------------------|--------------------|-------------------------|
| Foreign Priority claimed <input type="checkbox"/> yes <input checked="" type="checkbox"/> no | STATE OR COUNTRY CA | SHEETS DRAWING 6 | TOTAL CLAIMS 26 | INDEPENDENT CLAIMS 8 |
| 35 USC 119 (a-d) conditions met <input type="checkbox"/> yes <input checked="" type="checkbox"/> no <input type="checkbox"/> Met after Allowance | | | | |
| Verified and Acknowledged <i>[Signature]</i> Examiner's Signature | <i>JAC</i> Initials | | | |

ADDRESS
20995

TITLE
System and method for ordering and delivering media content

| | | |
|------------------------------------|---|--|
| FILING FEE RECEIVED 1398 | FEES: Authority has been given in Paper No. _____ to charge/credit DEPOSIT ACCOUNT No. _____ for following: | <input type="checkbox"/> All Fees |
| | | <input type="checkbox"/> 1.16 Fees (Filing) |
| | | <input type="checkbox"/> 1.17 Fees (Processing Ext. of time) |
| | | <input type="checkbox"/> 1.18 Fees (Issue) |
| | | <input type="checkbox"/> Other _____ |
| | | <input type="checkbox"/> Credit |

PART B - FEE(S) TRANSMITTAL

Complete and send this form, together with applicable fee(s), to: Mail

Mail Stop ISSUE FEE
 Commissioner for Patents
 P.O. Box 1450
 Alexandria, Virginia 22313-1450
 (703) 746-4000

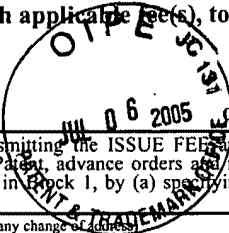

or Fax

INSTRUCTIONS: This form should be used for transmitting the ISSUE FEE and PUBLICATION FEE (if required). Blocks 1 through 5 should be completed where appropriate. All further correspondence including the Patent, advance orders and notification of maintenance fees will be mailed to the current correspondence address as indicated unless corrected below or directed otherwise in Block 1, by (a) specifying a new correspondence address; and/or (b) indicating a separate "FEE ADDRESS" for maintenance fee notifications.

CURRENT CORRESPONDENCE ADDRESS (Note: Use Block 1 for any change of address)

20995 7590 05/06/2005

KNOBBE MARTENS OLSON & BEAR LLP
 2040 MAIN STREET
 FOURTEENTH FLOOR
 IRVINE, CA 92614

Note: A certificate of mailing can only be used for domestic mailings of the Fee(s) Transmittal. This certificate cannot be used for any other accompanying papers. Each additional paper, such as an assignment or formal drawing, must have its own certificate of mailing or transmission.

Certificate of Mailing or Transmission

I hereby certify that this Fee(s) Transmittal is being deposited with the United States Postal Service with sufficient postage for first class mail in an envelope addressed to the Mail Stop ISSUE FEE address above, or being facsimile transmitted to the USPTO (703) 746-4000, on the date indicated below.

| |
|--------------------|
| (Depositor's name) |
| (Signature) |
| (Date) |

07/08/2005 BABRAHA2 00000001 09953335

01 FC:1501 1400.00 OP
 02 FC:1504 300.00 OP

| APPLICATION NO. | FILING DATE | FIRST NAMED INVENTOR | ATTORNEY DOCKET NO. | CONFIRMATION NO. |
|-----------------|-------------|----------------------|---------------------|------------------|
| 09/953,335 | 09/13/2001 | Kelly M. Christensen | STRATOS.001A | 4917 |

TITLE OF INVENTION: SYSTEM AND METHOD FOR ORDERING AND DELIVERING MEDIA CONTENT

| APPLN. TYPE | SMALL ENTITY | ISSUE FEE | PUBLICATION FEE | TOTAL FEE(S) DUE | DATE DUE |
|----------------|--------------|-----------|-----------------|------------------|------------|
| nonprovisional | NO | \$1400 | \$300 | \$1700 | 08/08/2005 |

| EXAMINER | ART UNIT | CLASS-SUBCLASS |
|-----------------|----------|----------------|
| KRAMER, JAMES A | 3627 | 705-027000 |

1. Change of correspondence address or indication of "Fee Address" (37 CFR 1.363).
 Change of correspondence address (or Change of Correspondence Address form PTO/SB/122) attached.
 "Fee Address" indication (or "Fee Address" Indication form PTO/SB/47; Rev 03-02 or more recent) attached. Use of a Customer Number is required.

2. For printing on the patent front page, list
 (1) the names of up to 3 registered patent attorneys or agents OR, alternatively,
 (2) the name of a single firm (having as a member a registered attorney or agent) and the names of up to 2 registered patent attorneys or agents. If no name is listed, no name will be printed.

1 KNOBBE MARTENS
 2 OLSON & BEAR LLP
 3 _____

3. ASSIGNEE NAME AND RESIDENCE DATA TO BE PRINTED ON THE PATENT (print or type)

PLEASE NOTE: Unless an assignee is identified below, no assignee data will appear on the patent. If an assignee is identified below, the document has been filed for recordation as set forth in 37 CFR 3.11. Completion of this form is NOT a substitute for filing an assignment.

(A) NAME OF ASSIGNEE

(B) RESIDENCE: (CITY and STATE OR COUNTRY)

STRATOSAUDIO, INC.

UNIVERSAL CITY, CALIFORNIA

Please check the appropriate assignee category or categories (will not be printed on the patent): Individual Corporation or other private group entity Government

4a. The following fee(s) are enclosed:

4b. Payment of Fee(s):

Issue Fee
 Publication Fee (No small entity discount permitted)
 Advance Order - # of Copies _____

A check in the amount of the fee(s) is enclosed.
 Payment by credit card. Form PTO-2038 is attached.
 The Director is hereby authorized by charge the required fee(s), or credit any overpayment, to Deposit Account Number 11-1410 (enclose an extra copy of this form).

5. Change in Entity Status (from status indicated above)

a. Applicant claims SMALL ENTITY status. See 37 CFR 1.27. b. Applicant is no longer claiming SMALL ENTITY status. See 37 CFR 1.27(g)(2).

The Director of the USPTO is requested to apply the Issue Fee and Publication Fee (if any) or to re-apply any previously paid issue fee to the application identified above. NOTE: The Issue Fee and Publication Fee (if required) will not be accepted from anyone other than the applicant; a registered attorney or agent; or the assignee or other party in interest as shown by the records of the United States Patent and Trademark Office.

Authorized Signature Perry Oldham
 Typed or printed name Perry Oldham

Date 7/1/2005
 Registration No. 52,082

This collection of information is required by 37 CFR 1.311. The information is required to obtain or retain a benefit by the public which is to file (and by the USPTO to process) an application. Confidentiality is governed by 35 U.S.C. 122 and 37 CFR 1.14. This collection is estimated to take 12 minutes to complete, including gathering, preparing, and submitting the completed application form to the USPTO. Time will vary depending upon the individual case. Any comments on the amount of time you require to complete this form and/or suggestions for reducing this burden, should be sent to the Chief Information Officer, U.S. Patent and Trademark Office, U.S. Department of Commerce, P.O. Box 1450, Alexandria, Virginia 22313-1450. DO NOT SEND FEES OR COMPLETED FORMS TO THIS ADDRESS. SEND TO: Commissioner for Patents, P.O. Box 1450, Alexandria, Virginia 22313-1450.

Under the Paperwork Reduction Act of 1995, no persons are required to respond to a collection of information unless it displays a valid OMB control number.

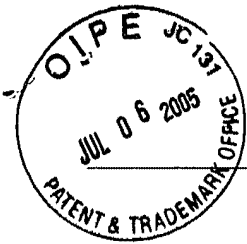

PATENT

Case Docket No. STRATOS.001A

Date: July 1, 2005

IN THE UNITED STATES PATENT AND TRADEMARK OFFICE

Applicant(s) : Kelly M. Christensen, et al.
Appl. No. : 09/953,335
Filed : September 13, 2001
For : SYSTEM AND METHOD FOR
ORDERING AND DELIVERING
MEDIA CONTENT
Group Art Unit : 3627
Class/Sub-Class : 705-027000
Examiner : James A. Kramer

I hereby certify that this correspondence and all marked attachments are being deposited with the United States Postal Service as first class mail in an envelope addressed to: Mail Stop Issue Fee, Commissioner for Patents, P.O. Box 1450, Alexandria, VA 22313-1450, on

July 1, 2005

(Date)

Perry D. Oldham, Reg. No. 52,082

TRANSMITTAL LETTER

MAIL STOP ISSUE FEE
Commissioner for Patents
P.O. Box 1450
Alexandria, VA 22313-1450

Dear Sir:

Enclosed for filing is the Issue Fee for the above-identified application:

- (X) Form PTOL-85.
- (X) A check in the amount of \$1700.00 to cover the issue fee and publication fee.
- (X) The Commissioner is hereby authorized to charge any additional fees which may be required, or credit any overpayment, to Account No. 11-1410.
- (X) Return prepaid postcard.

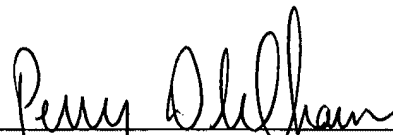
Perry D. Oldham
Registration No. 52,082
Attorney of Record
Customer No. 20,995
(949) 760-0404

1799192 070105

● PRINTER RUSH ●

(PTO ASSISTANCE)

| | | |
|---------------------------------|---------------------------------|-----------------------|
| Application : <u>09/953,335</u> | Examiner : <u>Kramer</u> | GAU : <u>3627</u> |
| From : <u>DP</u> | Location : <u>(IDC) FMF FDC</u> | Date : <u>8/22/05</u> |

Tracking #: 6119549 Week Date: 6/27/2005

| DOC CODE | DOC DATE | MISCELLANEOUS |
|---|-----------------|--|
| <input type="checkbox"/> 1449 | _____ | <input type="checkbox"/> Continuing Data |
| <input type="checkbox"/> IDS | _____ | <input type="checkbox"/> Foreign Priority |
| <input type="checkbox"/> CLM | _____ | <input type="checkbox"/> Document Legibility |
| <input type="checkbox"/> IIFW | _____ | <input type="checkbox"/> Fees |
| <input type="checkbox"/> SRFW | _____ | <input type="checkbox"/> Other |
| <input checked="" type="checkbox"/> DRW | <u>1/7/2002</u> | |
| <input type="checkbox"/> OATH | _____ | |
| <input type="checkbox"/> 312 | _____ | |
| <input type="checkbox"/> SPEC | _____ | |

[RUSH] MESSAGE: Attn: Chief Drafts person:
Stamp is covering Drawings, please provide
cleaner copy of Drawings set.

Thank you.

[XRUSH] RESPONSE: _____

Drawings corrected

INITIALS: WJG

NOTE: This form will be included as part of the official USPTO record, with the Response document coded as XRUSH.
 REV 10/04

FIG. 1A

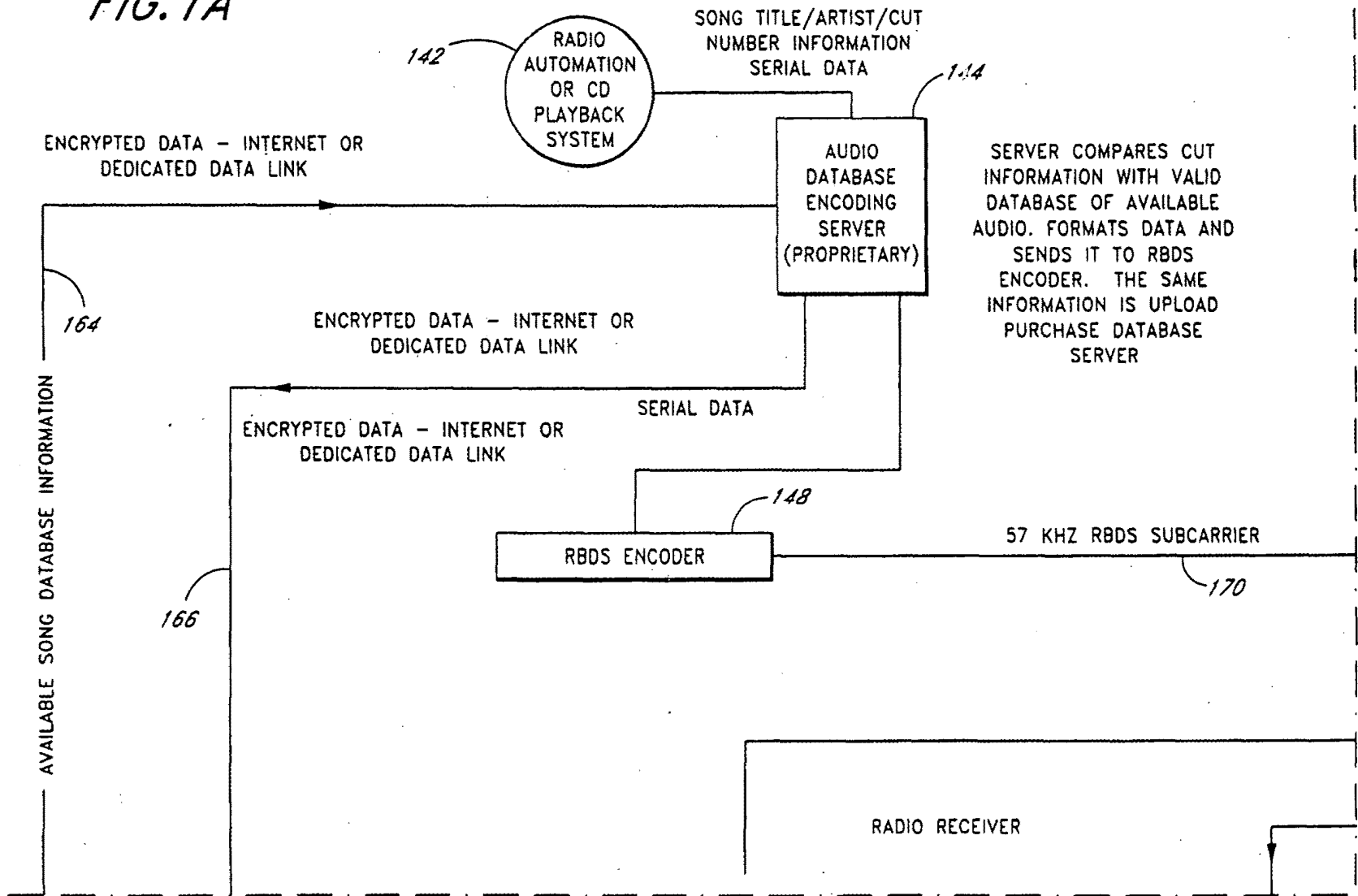

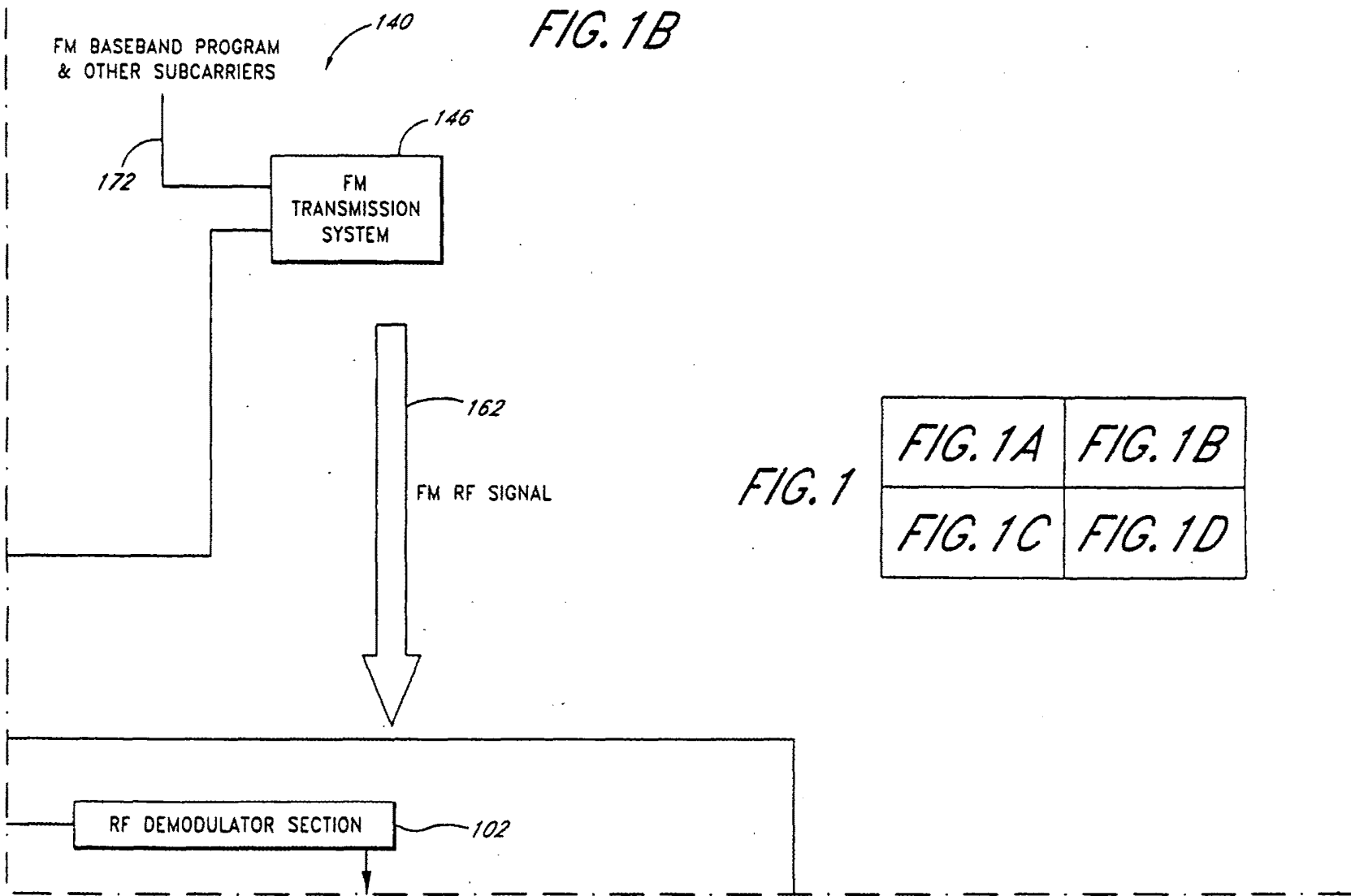

FIG. 1B

FIG. 1

| | |
|---------|---------|
| FIG. 1A | FIG. 1B |
| FIG. 1C | FIG. 1D |

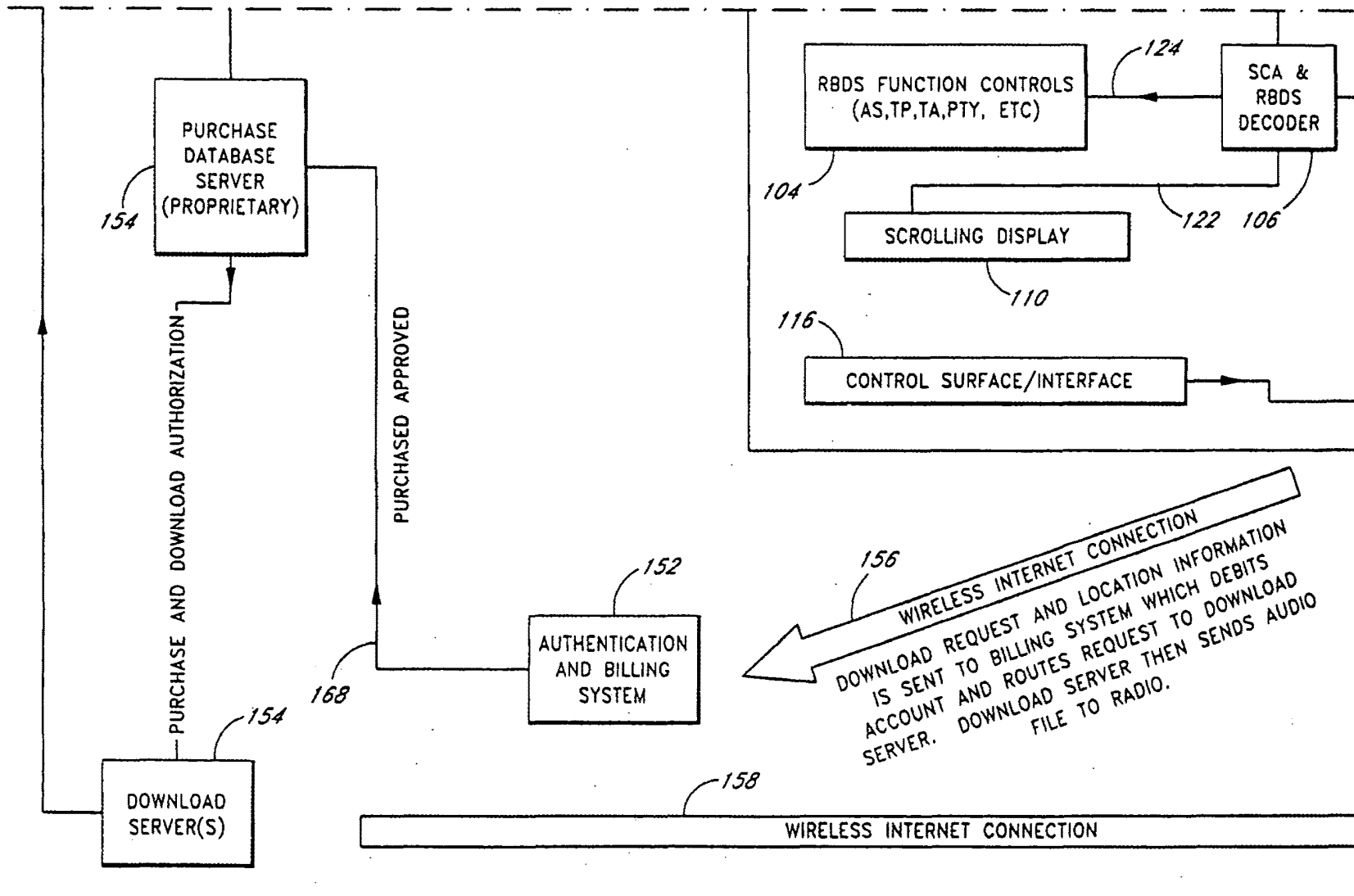

FIG. 1C

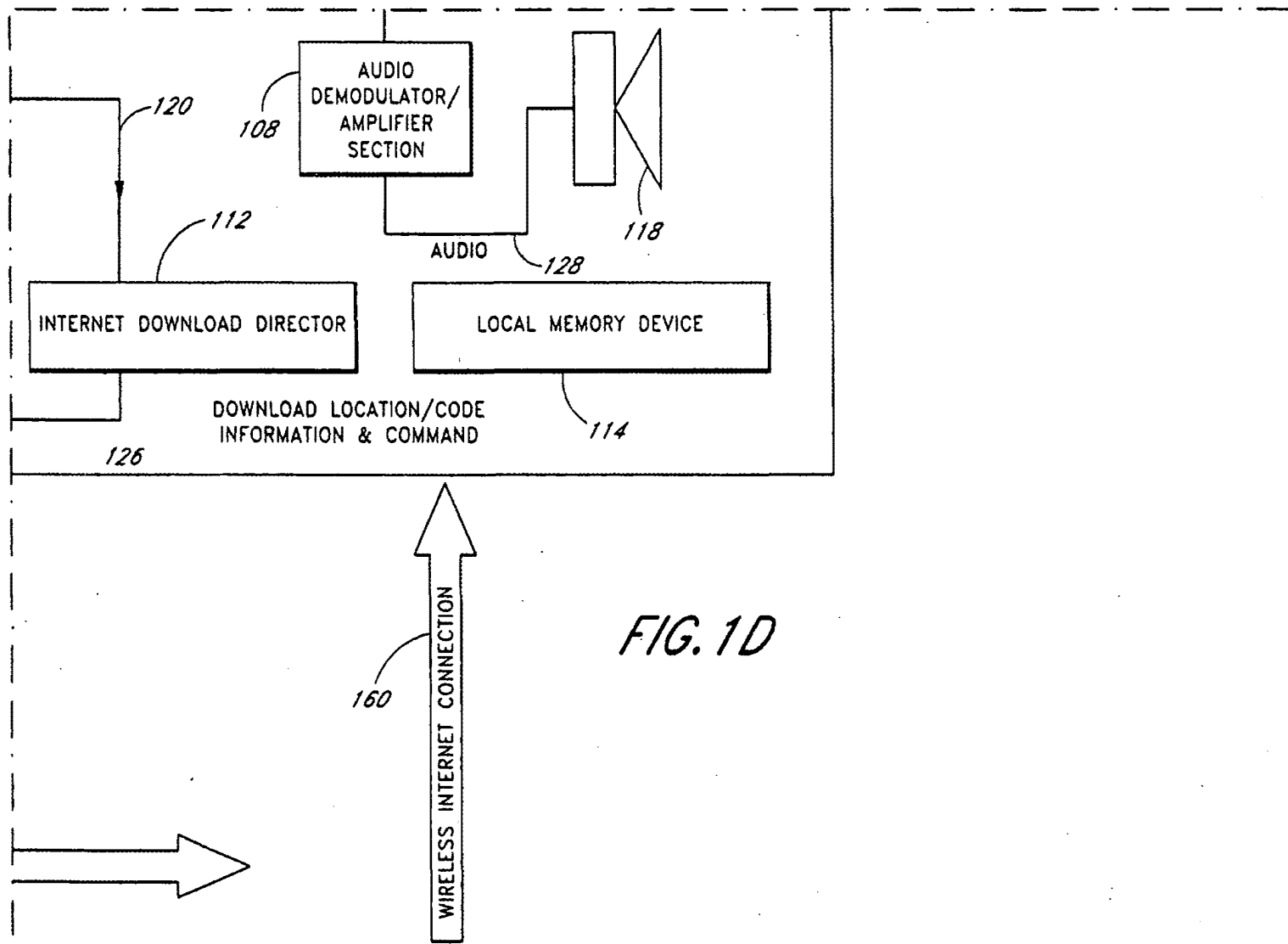
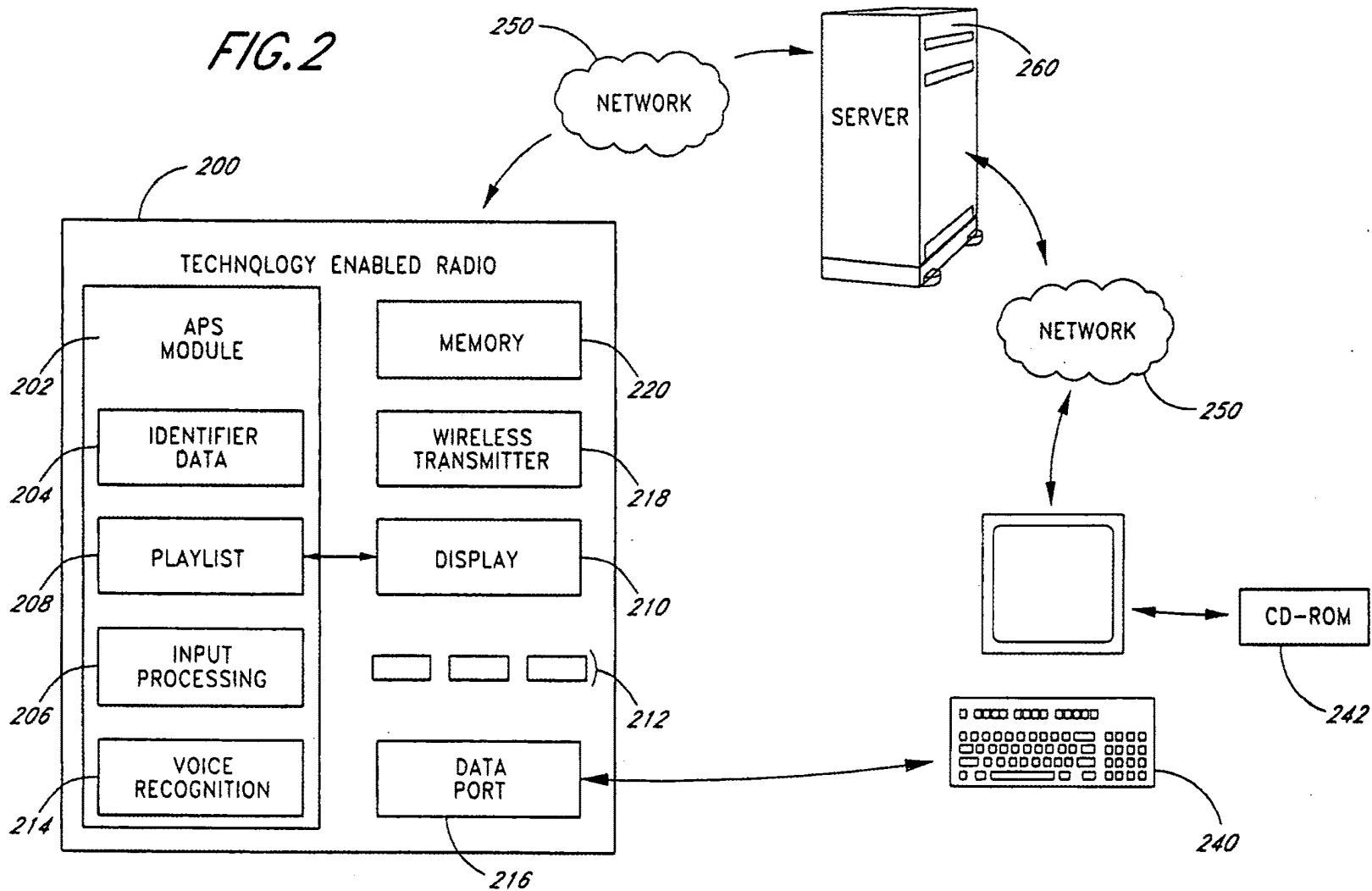

FIG. 1D

FIG. 2



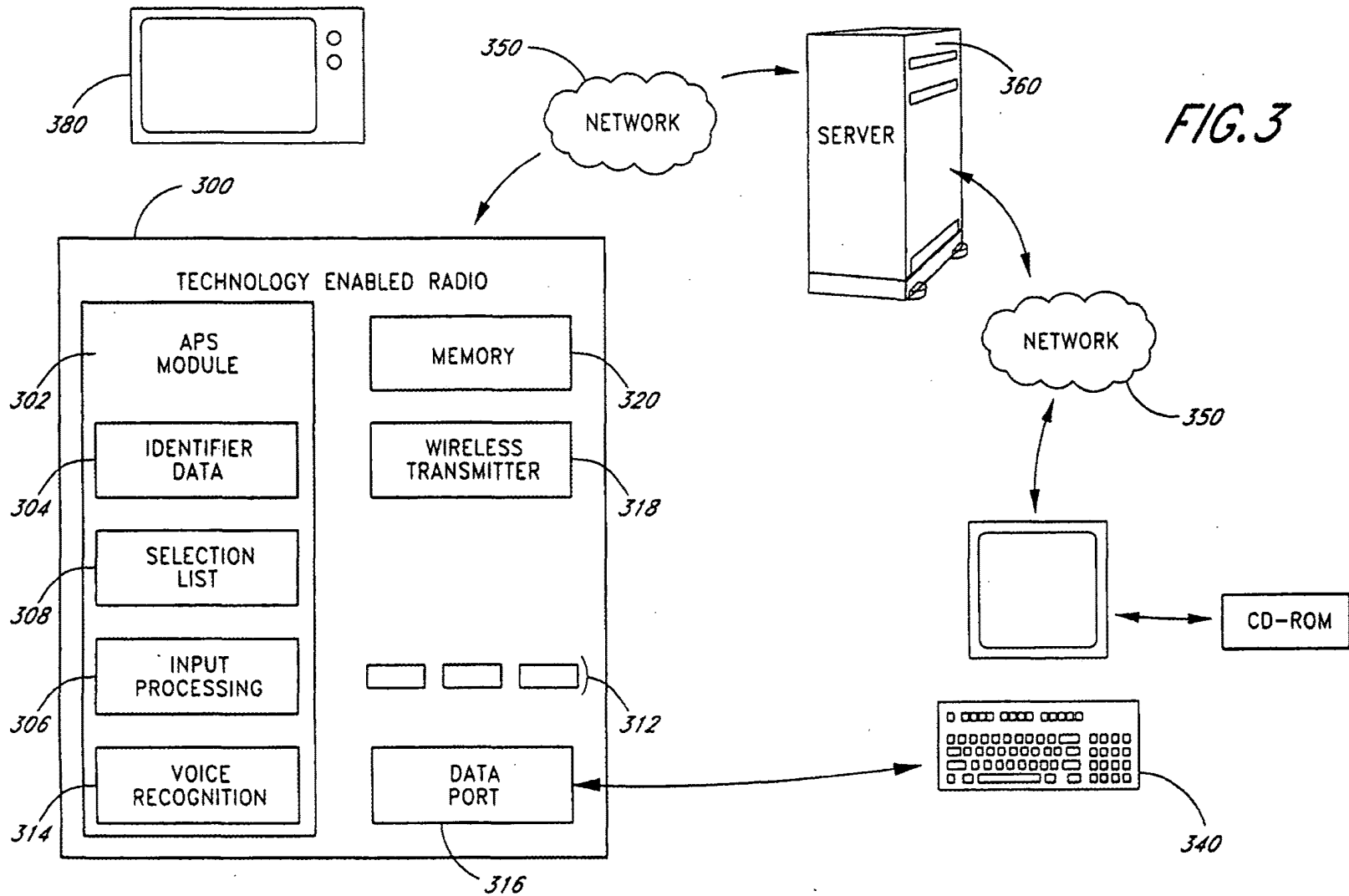

FIG. 3

**REVOCATION
AND
GENERAL POWER OF ATTORNEY**

Commissioner for Patents
P.O. Box 1450
Alexandria, VA 22313-1450

Dear Sir:

The undersigned is an empowered representative of the Assignee and hereby appoints the registrants of Knobbe, Martens, Olson & Bear, LLP, **Customer No. 20,995**, as attorneys and agents to represent the Assignee before the United States Patent and Trademark Office (USPTO) in connection with any and all patent applications assigned to the Assignee according to the USPTO assignment records or assignment documents supplied with an accompanying Statement Under 37 CFR § 3.73(b). This appointment is to be to the exclusion of the inventor(s) and his attorney(s) in accordance with the provisions of 37 CFR § 3.71.

Submission of this paper in connection with any matter of the below named assignee, together with a statement under 37 CFR 3.73(b), shall serve to revoke any previous powers of attorney in that matter.

A Statement Under 37 CFR § 3.73(b), signed by a registrant of Knobbe, Martens, Olson & Bear, LLP, is attached setting forth a full chain of title for the subject application owned by the Assignee named below.

Please recognize or change the correspondence address for the application identified in the attached Statement to **Customer No. 20,995**.

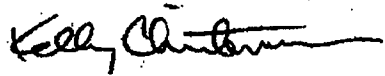
By:  Date: Feb 24, 2009

Name: Kelly Christensen Title: CEO

Assignee: STRATOSAUDIO, INC.

1800 Century Park East, Suite 600

Address: Century City, California 90067

Electronic Acknowledgement Receipt

| | |
|---|---|
| EFS ID: | 26745528 |
| Application Number: | 09953335 |
| International Application Number: | |
| Confirmation Number: | 4917 |
| Title of Invention: | SYSTEM AND METHOD FOR ORDERING AND DELIVERING MEDIA CONTENT |
| First Named Inventor/Applicant Name: | Kelly M. Christensen |
| Customer Number: | 20995 |
| Filer: | Morgan Ross Coates/Christina Graul |
| Filer Authorized By: | Morgan Ross Coates |
| Attorney Docket Number: | STRATOS.001A |
| Receipt Date: | 25-AUG-2016 |
| Filing Date: | 13-SEP-2001 |
| Time Stamp: | 15:11:10 |
| Application Type: | Utility under 35 USC 111(a) |

Payment information:

| | |
|------------------------|----|
| Submitted with Payment | no |
|------------------------|----|

File Listing:

| Document Number | Document Description | File Name | File Size(Bytes)/ Message Digest | Multi Part /.zip | Pages (if appl.) |
|-----------------|---|------------------|---|------------------|------------------|
| 1 | Assignee showing of ownership per 37 CFR 3.73 | 373Statement.pdf | 18094 <small>33c8c626817094e603b8bc4880f639fbcafd 1800</small> | no | 1 |

Warnings:

| Information: | | | | | |
|---|-------------------|-----------------------|--|-------|---|
| 2 | Power of Attorney | Power-of-Attorney.pdf | 50983 | no | 1 |
| | | | 01769683cefceb933c6c0cc5402f4283b79177e8 | | |
| Warnings: | | | | | |
| Information: | | | | | |
| Total Files Size (in bytes): | | | | 69077 | |
| <p>This Acknowledgement Receipt evidences receipt on the noted date by the USPTO of the indicated documents, characterized by the applicant, and including page counts, where applicable. It serves as evidence of receipt similar to a Post Card, as described in MPEP 503.</p> <p><u>New Applications Under 35 U.S.C. 111</u> If a new application is being filed and the application includes the necessary components for a filing date (see 37 CFR 1.53(b)-(d) and MPEP 506), a Filing Receipt (37 CFR 1.54) will be issued in due course and the date shown on this Acknowledgement Receipt will establish the filing date of the application.</p> <p><u>National Stage of an International Application under 35 U.S.C. 371</u> If a timely submission to enter the national stage of an international application is compliant with the conditions of 35 U.S.C. 371 and other applicable requirements a Form PCT/DO/EO/903 indicating acceptance of the application as a national stage submission under 35 U.S.C. 371 will be issued in addition to the Filing Receipt, in due course.</p> <p><u>New International Application Filed with the USPTO as a Receiving Office</u> If a new international application is being filed and the international application includes the necessary components for an international filing date (see PCT Article 11 and MPEP 1810), a Notification of the International Application Number and of the International Filing Date (Form PCT/RO/105) will be issued in due course, subject to prescriptions concerning national security, and the date shown on this Acknowledgement Receipt will establish the international filing date of the application.</p> | | | | | |

**STATEMENT UNDER 37 CFR § 3.73
ESTABLISHMENT OF ASSIGNEE**

| | | |
|----------------|---|---|
| First Inventor | : | Kelly M Christensen |
| App. No. | : | 09/953,335 |
| Filed | : | September 13, 2001 |
| For | : | SYSTEM AND METHOD FOR ORDERING AND DELIVERING MEDIA CONTENT |
| Examiner | : | James A. Kramer |
| Group Art Unit | : | 3627 |
| Conf No. | : | 4917 |

Commissioner for Patents
P.O. Box 1450
Alexandria, VA 22313-1450

Dear Sir:

This document is being filed with a copy of a Power of Attorney signed by the Assignee. This Statement sets forth the chain of title of the above-identified application.

STRATOSAUDIO, INC., a Corporation, is the Assignee of the entire right, title, and interest of the above-referenced application by virtue of:

The Assignment from the inventors to the Assignee recorded in the United States Patent and Trademark Office on December 17, 2001, at Reel 012361, and Frame 0935.

The undersigned is an agent of Customer No. 20995 and is authorized to act on behalf of the Assignee. Please recognize or change the correspondence address for the above-identified application to **Customer No. 20995**.

Respectfully submitted,
KNOBBE, MARTENS, OLSON & BEAR, LLP

Dated: August 25, 2016

By: Morgan Coates/
Morgan Coates
Registration No. 64,970
Attorney of Record
Customer No.
(949) 760-0404



UNITED STATES PATENT AND TRADEMARK OFFICE

UNITED STATES DEPARTMENT OF COMMERCE
United States Patent and Trademark Office
Address: COMMISSIONER FOR PATENTS
P.O. Box 1450
Alexandria, Virginia 22313-1450
www.uspto.gov

| APPLICATION NUMBER | FILING OR 371(C) DATE | FIRST NAMED APPLICANT | ATTY. DOCKET NO./TITLE |
|--------------------|-----------------------|-----------------------|------------------------|
| 09/953,335 | 09/13/2001 | Kelly M. Christensen | STRATOS.000GEN |

CONFIRMATION NO. 4917

POA ACCEPTANCE LETTER

20995
KNOBBE MARTENS OLSON & BEAR LLP
2040 MAIN STREET
FOURTEENTH FLOOR
IRVINE, CA 92614



Date Mailed: 08/30/2016

NOTICE OF ACCEPTANCE OF POWER OF ATTORNEY

This is in response to the Power of Attorney filed 08/25/2016.

The Power of Attorney in this application is accepted. Correspondence in this application will be mailed to the above address as provided by 37 CFR 1.33.

Questions about the contents of this notice and the requirements it sets forth should be directed to the Office of Data Management, Application Assistance Unit, at (571) 272-4000 or (571) 272-4200 or 1-888-786-0101.

/dtvernon/



UNITED STATES PATENT AND TRADEMARK OFFICE

UNITED STATES DEPARTMENT OF COMMERCE
United States Patent and Trademark Office
Address: COMMISSIONER FOR PATENTS
P.O. Box 1450
Alexandria, Virginia 22313-1450
www.uspto.gov

Table with 4 columns: APPLICATION NUMBER (09/953,335), PATENT NUMBER (6957041), GROUP ART UNIT (3627), REQUEST ID (24220)

PAIR Correspondence Address/Fee Address Change

The following fields have been changed to Customer Number 197 on 08/30/2016 via Private PAIR in view of the certification copied below that authorized the change.

- Maintenance Fee Address

The address for Customer Number 197 is:

197
CPA GLOBAL LIMITED
2318 Mill Road 12th Floor
ALEXANDRIA, VA 22314

I certify, in accordance with 37 CFR 1.4(d)(4) that I am:

An attorney or Agent of Record registered to practice before the Patent and Trademark Office who has been given power of attorney in this application

Table with 2 columns: Signature (Morgan Coates), Name (Morgan Coates), Registration Number (64970)