

Under the Paperwork Reduction Act of 1995, no persons are required to respond to a collection of information unless it contains a valid OMB control number.

<b>Application Data Sheet 37 CFR 1.76</b>		Attorney Docket Number	QAP
		Application Number	
Title of Invention	Proximity Sensor		
<p>The application data sheet is part of the provisional or nonprovisional application for which it is being submitted. The following form contains the bibliographic data arranged in a format specified by the United States Patent and Trademark Office as outlined in 37 CFR 1.76. This document may be completed electronically and submitted to the Office in electronic format using the Electronic Filing System (EFS) or the document may be printed and included in a paper filed application.</p>			

**Secrecy Order 37 CFR 5.2**

Portions or all of the application associated with this Application Data Sheet may fall under a Secrecy Order pursuant to 37 CFR 5.2 (Paper filers only. Applications that fall under Secrecy Order may not be filed electronically.)

**Applicant Information:**

<b>Applicant 1</b>					<input type="button" value="Remove"/>
<b>Applicant Authority</b>		<input checked="" type="radio"/> Inventor		<input type="radio"/> Legal Representative under 35 U.S.C. 117	
				<input type="radio"/> Party of Interest under 35 U.S.C. 118	
<b>Prefix</b>	<b>Given Name</b>	<b>Middle Name</b>	<b>Family Name</b>	<b>Suffix</b>	
	Harald		Philipp		
<b>Residence Information (Select One)</b> <input type="radio"/> US Residency <input checked="" type="radio"/> Non US Residency <input type="radio"/> Active US Military Service					
<b>City</b>	Southampton	<b>Country Of Residence<sup>i</sup></b>	GB		
<b>Citizenship under 37 CFR 1.41(b)<sup>i</sup></b>		US			
<b>Mailing Address of Applicant:</b>					
<b>Address 1</b>	QRG Limited				
<b>Address 2</b>	1 Mitchell Point, Ensign Way				
<b>City</b>	Hamble, Hampshire		<b>State/Province</b>		
<b>Postal Code</b>	SO31 4RF	<b>Country<sup>i</sup></b>	GB		
<b>Applicant 2</b>					<input type="button" value="Remove"/>
<b>Applicant Authority</b>		<input checked="" type="radio"/> Inventor		<input type="radio"/> Legal Representative under 35 U.S.C. 117	
				<input type="radio"/> Party of Interest under 35 U.S.C. 118	
<b>Prefix</b>	<b>Given Name</b>	<b>Middle Name</b>	<b>Family Name</b>	<b>Suffix</b>	
	Kevin		Snod		
<b>Residence Information (Select One)</b> <input type="radio"/> US Residency <input checked="" type="radio"/> Non US Residency <input type="radio"/> Active US Military Service					
<b>City</b>	Chichester	<b>Country Of Residence<sup>i</sup></b>	GB		
<b>Citizenship under 37 CFR 1.41(b)<sup>i</sup></b>		GB			
<b>Mailing Address of Applicant:</b>					
<b>Address 1</b>	QRG Limited				
<b>Address 2</b>	1 Mitchell Point, Ensign Way				
<b>City</b>	Hamble, Hampshire		<b>State/Province</b>		
<b>Postal Code</b>	SO31 4RF	<b>Country<sup>i</sup></b>	GB		
All Inventors Must Be Listed - Additional Inventor Information blocks may be generated within this form by selecting the <b>Add</b> button.					<input type="button" value="Add"/>

**Correspondence Information:**

Enter either Customer Number or complete the Correspondence Information section below.  
For further information see 37 CFR 1.33(a).

An Address is being provided for the correspondence information of this application.

<b>Application Data Sheet 37 CFR 1.76</b>		Attorney Docket Number	QAP
		Application Number	
Title of Invention	Proximity Sensor		
Customer Number	20191		
Email Address	dak@patent-faq.com	<input type="button" value="Add Email"/>	<input type="button" value="Remove Email"/>

**Application Information:**

Title of the Invention	Proximity Sensor		
Attorney Docket Number	QAP	Small Entity Status Claimed	<input type="checkbox"/>
Application Type	Nonprovisional		
Subject Matter	Utility		
Suggested Class (if any)		Sub Class (if any)	
Suggested Technology Center (if any)			
Total Number of Drawing Sheets (if any)	10	Suggested Figure for Publication (if any)	17

**Publication Information:**

<input type="checkbox"/>	Request Early Publication (Fee required at time of Request 37 CFR 1.219)
<input type="checkbox"/>	<b>Request Not to Publish.</b> I hereby request that the attached application not be published under 35 U.S. C. 122(b) and certify that the invention disclosed in the attached application <b>has not and will not</b> be the subject of an application filed in another country, or under a multilateral international agreement, that requires publication at eighteen months after filing.

**Representative Information:**

Representative information should be provided for all practitioners having a power of attorney in the application. Providing this information in the Application Data Sheet does not constitute a power of attorney in the application (see 37 CFR 1.32). Enter either Customer Number or complete the Representative Name section below. If both sections are completed the Customer Number will be used for the Representative Information during processing.			
Please Select One:	<input checked="" type="radio"/> Customer Number	<input type="radio"/> US Patent Practitioner	<input type="radio"/> Limited Recognition (37 CFR 11.9)
Customer Number	20191		

**Domestic Benefit/National Stage Information:**

This section allows for the applicant to either claim benefit under 35 U.S.C. 119(e), 120, 121, or 365(c) or indicate National Stage entry from a PCT application. Providing this information in the application data sheet constitutes the specific reference required by 35 U.S.C. 119(e) or 120, and 37 CFR 1.78(a)(2) or CFR 1.78(a)(4), and need not otherwise be made part of the specification.			
Prior Application Status	Pending	<input type="button" value="Remove"/>	
Application Number	Continuity Type	Prior Application Number	Filing Date (YYYY-MM-DD)
	non provisional of	60952053	2007-07-26
Additional Domestic Benefit/National Stage Data may be generated within this form by selecting the <b>Add</b> button.			<input type="button" value="Add"/>

**Foreign Priority Information:**

Under the Paperwork Reduction Act of 1995, no persons are required to respond to a collection of information unless it contains a valid OMB control number.

<b>Application Data Sheet 37 CFR 1.76</b>		Attorney Docket Number	QAP
		Application Number	
Title of Invention	Proximity Sensor		

This section allows for the applicant to claim benefit of foreign priority and to identify any prior foreign application for which priority is not claimed. Providing this information in the application data sheet constitutes the claim for priority as required by 35 U.S.C. 119(b) and 37 CFR 1.55(a).

<input type="button" value="Remove"/>			
Application Number	Country <sup>i</sup>	Parent Filing Date (YYYY-MM-DD)	Priority Claimed
			<input type="radio"/> Yes <input checked="" type="radio"/> No
Additional Foreign Priority Data may be generated within this form by selecting the <b>Add</b> button.			<input type="button" value="Add"/>

**Assignee Information:**

Providing this information in the application data sheet does not substitute for compliance with any requirement of part 3 of Title 37 of the CFR to have an assignment recorded in the Office.

<b>Assignee 1</b>				<input type="button" value="Remove"/>
If the Assignee is an Organization check here. <input checked="" type="checkbox"/>				
Organization Name	QRG Limited			
<b>Mailing Address Information:</b>				
Address 1	Rothman Pantall & Co.			
Address 2	10 Romsey Road			
City	Eastleigh, Hampshire	State/Province		
Country <sup>i</sup>	GB	Postal Code	SO50 9AL	
Phone Number		Fax Number		
Email Address				
Additional Assignee Data may be generated within this form by selecting the <b>Add</b> button.				<input type="button" value="Add"/>

**Signature:**

A signature of the applicant or representative is required in accordance with 37 CFR 1.33 and 10.18. Please see 37 CFR 1.4(d) for the form of the signature.

Signature	/David A Kiewit/		Date (YYYY-MM-DD)	2008-07-25
First Name	David	Last Name	Kiewit	Registration Number
				34640

This collection of information is required by 37 CFR 1.76. The information is required to obtain or retain a benefit by the public which is to file (and by the USPTO to process) an application. Confidentiality is governed by 35 U.S.C. 122 and 37 CFR 1.14. This collection is estimated to take 23 minutes to complete, including gathering, preparing, and submitting the completed application data sheet form to the USPTO. Time will vary depending upon the individual case. Any comments on the amount of time you require to complete this form and/or suggestions for reducing this burden, should be sent to the Chief Information Officer, U.S. Patent and Trademark Office, U.S. Department of Commerce, P.O. Box 1450, Alexandria, VA 22313-1450. DO NOT SEND FEES OR COMPLETED FORMS TO THIS ADDRESS. **SEND TO: Commissioner for Patents, P.O. Box 1450, Alexandria, VA 22313-1450.**

## Privacy Act Statement

The Privacy Act of 1974 (P.L. 93-579) requires that you be given certain information in connection with your submission of the attached form related to a patent application or patent. Accordingly, pursuant to the requirements of the Act, please be advised that: (1) the general authority for the collection of this information is 35 U.S.C. 2(b)(2); (2) furnishing of the information solicited is voluntary; and (3) the principal purpose for which the information is used by the U.S. Patent and Trademark Office is to process and/or examine your submission related to a patent application or patent. If you do not furnish the requested information, the U.S. Patent and Trademark Office may not be able to process and/or examine your submission, which may result in termination of proceedings or abandonment of the application or expiration of the patent.

The information provided by you in this form will be subject to the following routine uses:

1. The information on this form will be treated confidentially to the extent allowed under the Freedom of Information Act (5 U.S.C. 552) and the Privacy Act (5 U.S.C. 552a). Records from this system of records may be disclosed to the Department of Justice to determine whether the Freedom of Information Act requires disclosure of these records.
2. A record from this system of records may be disclosed, as a routine use, in the course of presenting evidence to a court, magistrate, or administrative tribunal, including disclosures to opposing counsel in the course of settlement negotiations.
3. A record in this system of records may be disclosed, as a routine use, to a Member of Congress submitting a request involving an individual, to whom the record pertains, when the individual has requested assistance from the Member with respect to the subject matter of the record.
4. A record in this system of records may be disclosed, as a routine use, to a contractor of the Agency having need for the information in order to perform a contract. Recipients of information shall be required to comply with the requirements of the Privacy Act of 1974, as amended, pursuant to 5 U.S.C. 552a(m).
5. A record related to an International Application filed under the Patent Cooperation Treaty in this system of records may be disclosed, as a routine use, to the International Bureau of the World Intellectual Property Organization, pursuant to the Patent Cooperation Treaty.
6. A record in this system of records may be disclosed, as a routine use, to another federal agency for purposes of National Security review (35 U.S.C. 181) and for review pursuant to the Atomic Energy Act (42 U.S.C. 218(c)).
7. A record from this system of records may be disclosed, as a routine use, to the Administrator, General Services, or his/her designee, during an inspection of records conducted by GSA as part of that agency's responsibility to recommend improvements in records management practices and programs, under authority of 44 U.S.C. 2904 and 2906. Such disclosure shall be made in accordance with the GSA regulations governing inspection of records for this purpose, and any other relevant (i.e., GSA or Commerce) directive. Such disclosure shall not be used to make determinations about individuals.
8. A record from this system of records may be disclosed, as a routine use, to the public after either publication of the application pursuant to 35 U.S.C. 122(b) or issuance of a patent pursuant to 35 U.S.C. 151. Further, a record may be disclosed, subject to the limitations of 37 CFR 1.14, as a routine use, to the public if the record was filed in an application which became abandoned or in which the proceedings were terminated and which application is referenced by either a published application, an application open to public inspections or an issued patent.
9. A record from this system of records may be disclosed, as a routine use, to a Federal, State, or local law enforcement agency, if the USPTO becomes aware of a violation or potential violation of law or regulation.

A capacitive touch sensor providing an automatic switch-off function for an apparatus in which the sensor is incorporated is provided. The sensor comprises a sensing element coupled to a capacitance measurement circuit for measuring the capacitance of the sensing element. A control circuit is operable to determine from the capacitance measurement whether an object is in proximity with the sensor. The determined presence of an object may be used to toggle a function of the apparatus. Furthermore, when it is determined that an object has not been in proximity with the sensor for a predetermined time duration, an output signal for switching off the apparatus is provided. The predetermined time duration may be selected from a number of predefined time durations, or may be programmed using a resistor-capacitor network. Pulses may be applied to the control circuit to override features of the automatic switch-off functionality.

## BACKGROUND ART

**[0001]** This invention relates to proximity sensors. In particular, the invention relates to capacitive sensors for sensing the presence or touch of an object adjacent to a sensor.

**[0002]** Capacitive position sensors have recently become increasingly common and accepted in human interfaces and for machine control. For example, in the fields of portable media players it is now quite common to find capacitive touch controls operable through glass or plastic panels. Some mobile (cellular) telephones are also starting to implement these kinds of interfaces.

**[0003]** Many capacitive touch controls incorporated into consumer electronic devices for appliances provide audio and/or visual feedback to a user indicating whether a finger or other pointing object is present or approaches such touch controls. A capacitive sensing microprocessor may typically be comprised in touch-controlled devices which are arranged to provide an “on” output signal when a finger is adjacent to a sensor and an “off” output signal when a finger is not adjacent to a sensor. The signals are sent to a device controller to implement a required function dependent on whether a user’s finger is in proximity with or touching an associated touch control.

**[0004]** Some touch-controlled devices remain “on” or “active” despite the user having moved away from the device or a particular function no longer being required. This results in the device consuming a large amount of power which is not efficient.

**[0005]** There is therefore a need for an improved capacitive touch sensor which can regulate power usage.

## SUMMARY OF THE INVENTION

**[0006]** According to a first aspect of the invention there is provided a sensor for determining the presence of an object comprising: a sensing element; a capacitance measurement circuit operable to measure the capacitance of the sensing element; and a control circuit operable to determine whether an object is in proximity with the sensor based on a measurement of the capacitance of the sensing element, the control circuit further being operable to provide an output signal to control a function of an apparatus when it is determined that an object has not been in proximity with the sensor for a predetermined time duration.

**[0007]** The control circuit may be configured so that the predetermined time duration is selectable from a number of different predefined time durations.

**[0008]** The control circuit may include a time input terminal and the predetermined time duration may be selectable from the number of different predefined time durations according to a voltage applied to the time input terminal.

**[0009]** The control circuit may include a delay multiplier terminal and be configured so that a selected one of the number of different predefined time durations is multiplied by a multiplication factor according to a voltage applied to the delay multiplier terminal so as to provide the predetermined time duration.

**[0010]** The control circuit may be configured so that the predetermined time duration is programmable by a user to provide a user-selected time duration.

**[0011]** The sensor may comprise a resistor-capacitor (RC) network coupled to the control circuit and the predetermined time duration may depend on a time constant of the RC network.

**[0012]** The control circuit may include a delay multiplier terminal and be configured so that the user-selected time duration is multiplied by a multiplication factor according to a voltage applied to the delay multiplier terminal to provide the predetermined time duration.

**[0013]** The control circuit may be configured such that the provision of the output signal to control a function of an apparatus after the predetermined time duration may be overridden so the output signal is not provided when it is determined that an object has not been in proximity with the sensor for a predetermined time duration. For example, the control circuit may be operable to receive an override pulse and on receipt of the override pulse to retrigger the predetermined time duration to so as to extend the time before the output signal to control a function of an apparatus is provided.

**[0014]** The control circuit may be configured such that the provision of the output signal to control a function of an apparatus after the predetermined time duration may be overridden so the output signal is provided before it is determined that an object has not been in proximity with the sensor for a predetermined time duration. For example, the control circuit may be operable to receive an override pulse and on receipt of the override pulse to provide the output signal to control a function of an apparatus.

**[0015]** The sensor may be configured to perform a recalibration when the sensor is powered up, when an object is determined to be in proximity with the sensor for more than a timer setting, and / or when an override is released.



[0016] The control circuit may be configured such that the output signal is toggled between a high state and a low state when an object is determined to be in proximity with the sensor.

[0017] The function of an apparatus controlled by the output signal may be a switch-off function.

[0018] The capacitance measurement circuit may employ bursts of charge-transfer cycles to acquire measurements.

[0019] The capacitance measurement circuit may be configured to operate in one of more than one acquisition modes depending on the output signal, for example a low-power mode or a fast mode.

[0020] The capacitance measurement circuit and the control circuit may be comprised in a general purpose microcontroller under firmware control.

[0021] The capacitance measurement circuit and the control circuit may be comprised within a six-pin integrated circuit chip package, such as an SOT23-6.

[0022] According to a second aspect of the invention there is provided apparatus comprising a sensor according to the first aspect of the invention.

[0023] According to a third aspect of the invention there is provided a method for controlling a function of an apparatus comprising: determining whether an object is in proximity with a sensor based on a measurement of the capacitance of a sensing element and providing an output signal to control the function of the apparatus when it is determined that an object has not been in proximity with the sensor for a predetermined time duration.

[0024] The function of the apparatus controlled by the output signal may be a switch-off function.

**[0025]** According to another aspect of the present invention, there is provided a sensor for determining the presence of an object comprising: a sensing element, a capacitance measurement circuit operable to measure the capacitance of the sensing element, and a control circuit operable to determine whether an object is in proximity with the sensor based on a measurement of the capacitance of the sensing element, the control circuit also being operable to provide an output signal to control a function of an apparatus based on an object not being in proximity with the sensor and the output signal being produced after a predetermined time duration.

#### BRIEF DESCRIPTION OF THE DRAWINGS

**[0026]** For a better understanding of the invention and to show how the same may be carried into effect reference is now made by way of example to the accompanying drawings in which:

**[0027]** Figure 1 schematically shows sense electrode connections for an example chip for implementing an auto-off function according to an embodiment of the invention;

**[0028]** Figure 2 schematically represent an application of drift compensation in the chip of Figure 1;

**[0029]** Figure 3 schematically shows a basic circuit configuration for providing a 15 minute auto switch-off function in an active high output implementation of an embodiment of the invention;

**[0030]** Figure 4 schematically shows a series of fast mode bursts on the SNSK pin of the chip shown in Figure 1 when in an on condition;

**[0031]** Figure 5 schematically shows a series of low-power mode bursts and a switch to fast mode power bursts on the SNSK pin of the chip shown in Figure 1 when switching from an off condition to an on condition;

**[0032]** Figure 6 schematically shows use of an output configuration resistor  $R_{op}$  to configure the chip of Figure 1 to have an active high or an active low output;

**[0033]** Figure 7 schematically shows an example circuit configuration for the chip shown in Figure 1 with the output connected to a digital transistor;

**[0034]** Figure 8 schematically shows an example circuit configuration for the chip shown in Figure 1 configured to provide a predefined auto-off delay;

**[0035]** Figure 9 schematically shows an example circuit configuration for the chip shown in Figure 1 configured to provide a programmable auto-off delay;

**[0036]** Figure 10 schematically shows an example pulse applied to the chip shown in Figure 1 to override an auto-off delay;

**[0037]** Figure 11 schematically shows another example pulse applied to the chip shown in Figure 1 to override an auto-off delay;

**[0038]** Figure 12 schematically shows example voltage levels for the chip shown in Figure 1 in overriding of an auto-off delay;

**[0039]** Figures 13 and 14 schematically show typical values of RC divisor  $K$  as a function of supply voltage  $V_{DD}$  for the chip shown in Figure 1 with active high output and active low output respectively;

**[0040]** Figure 15 schematically shows typical curves of auto-off delay as a function of timing resistor value for different capacitor values and different supply voltages for an active high output configuration;

**[0041]** Figure 16 schematically shows typical curves of auto-off delay as a function of timing resistor value for different capacitor values and different supply voltages for an active low output configuration;

**[0042]** Figure 17 schematically shows an example application of the chip shown in Figure 1 in an active low output configuration driving a PNP transistor with an auto-off time of 3.33 hours;

**[0043]** Figure 18 schematically shows another example application of the chip shown in Figure 1 in an active high output configuration driving a high impedance with an auto-off time of 135 seconds;

**[0044]** Figure 19 schematically shows an implementation of the chip shown in Figure 1 in an SOT23-6 package; and

**[0045]** Figure 20 schematically shows a pin diagram for an implementation of the chip shown in Figure 1 in an SOT23-6 package.

#### DETAILED DESCRIPTION

**[0046]** In one example, an embodiment of the invention may be implemented in an integrated circuit chip providing a proximity sensor function. The integrated circuit chip may thus be incorporated into a device or apparatus to provide and control a proximity sensor functionality for the device / apparatus in accordance with an embodiment of the invention. For the purposes of explanation, a specific integrated circuit chip providing the functionality of an embodiment of the invention will be described further below. The chip will in places be referred to by product name QT102. However, it will be appreciated that the QT102 chip is merely a specific example application of an embodiment

of the invention. Other embodiments of the invention need not be implemented in a chip in this way, and furthermore, other embodiments of the invention may be provided in conjunction with all, some or none of the additional features of the QT102 chip described further below.

**[0047]** Before turning specifically to the QT102 chip embodiment, a summary is provided.

**[0048]** It is known that a touch sensitive sensor may comprise a sensor element, such as an etched copper electrode mounted on a PCB substrate, and a control circuit for measuring a capacitance of the sensor element to a system reference potential. The sensor element may be referred to as a sense electrode. The capacitance of the sense electrode is affected by the presence of nearby objects, such as a pointing finger. Thus the measured capacitance of the sense electrode, and in particular changes in the measured capacitance, may be used to identify the presence of an object adjacent the sense electrode. The control circuit may be configured to provide an output signal, e.g. by setting an output logic level as high or low, indicating whether or not an object is deemed to be adjacent the sense electrode. A controller of a device in which the touch sensitive sensor is implemented may receive the output signal and act accordingly.

**[0049]** There are various known technologies for measuring capacitance of a sense electrode in a capacitive touch sensor. Embodiments of the present invention may be implemented in conjunction with any of these technologies / measurement circuits. For example, the fundamental principles underlying the capacitive sensors described in US 5,730,165, US 6,466,036 and US 6,452,514 could be used.

**[0050]** In accordance with embodiments of the invention, the control circuit of the sensor can determine whether an object or a user's finger is no longer in proximity with the sensor and based on a pre-determined time duration, the

control circuit can produce an output signal automatically to prevent the capacitance measurement circuit from continually measuring changes in capacitance due to, for example, the perceived presence of an object in proximity with the sensor.

**[0051]** Therefore, the control circuit is able to deactivate, turn-off, or power down the capacitance measurement circuit where an apparatus has inadvertently been left on or with the erroneous perception that a user is still present. This may, for example, be referred to as an “auto-off” feature. The signal for preventing the capacitance measurement circuit from continually measuring changes in capacitance may be referred to as an auto-off signal. The capacitance measurement circuit and the auto-off control circuit may be comprised in a general-purpose microcontroller under firmware control, for example, such as the QT102 chip described further below.

**[0052]** As described in Section 3.5 of the below numbered sections, and in conjunction with the drawings, the control circuit of the sensor may be implemented by different methods — for example, the auto-off signal output may be produced automatically after different pre-determined time durations to effect powering down the capacitance measurement circuit due to no presence of the user; the control circuit may be programmed by a user so that it may power down an apparatus based on a user-selected time duration; the control circuit output signals may be overridden, for example, to extend time durations before an apparatus is turned-off or to immediately turn-off an apparatus when a user is no longer present.

**[0053]** The sensor of the invention may be useful in various applications, for example in kitchen appliances, light switches, headsets, and other electronic consumer devices. For example, a coffee machine incorporating a sensor of the invention may be programmed to power-down after a time period of, say, 30 minutes, where the coffee machine has been left on inadvertently. This will

beneficially conserve energy use and minimise the possibility of damage and/or accidents caused by the coffee machine or glass container(s) overheating.

**[0054]** Aspects of the QT102 chip referred to above, and which incorporates an embodiment of the invention, will now be described in the following numbered sections.

**[0055]** The numbered sections may be considered to relate generally to features of the QT102 chip as follows: Section 1 - Overview (including 1.1 Introduction, 1.2 Electrode Drive, 1.3 Sensitivity, 1.3.1 Introduction, 1.3.2 Increasing Sensitivity, 1.3.3 Decreasing Sensitivity, 1.4 Recalibration Timeout , 1.5 Forced Sensor Recalibration, 1.6 Drift Compensation, 1.7 Response Time, 1.8 Spread Spectrum). Section 2 -Wiring and Parts (including 2.1 Application Note, 2.2 Cs Sample Capacitor, 2.3 Rs Resistor, 2.4 Power Supply, PCB Layout, 2.5 Wiring). Section 3 - Operation (including 3.1 Acquisition Modes, 3.1.1 Introduction, 3.1.2 OUT Pin 'On' (Fast Mode), 3.1.3 OUT Pin 'Off ' (Low Power Mode), 3.2 Signal Processing, 3.2.1 Detect Integrator, 3.2.2 Detect Threshold, 3.3 Output Polarity Selection, 3.4 Output Drive, 3.5 Auto Off Delay, 3.5.1 Introduction, 3.5.2 Auto Off - Predefined Delay, 3.5.3 Auto Off - User-programmed Delay, 3.5.4 Auto Off - Overriding the Auto Off Delay, 3.5.5 Configuring the User-programmed Auto-off Delay, 3.6 Examples of Typical Applications). Section 4 - Specifications (including 4.1 Absolute Maximum Specifications, 4.2 Recommended Operating Conditions, 4.3 AC Specifications, 4.4 Signal Processing, 4.5 DC Specifications, 4.6 Mechanical Dimensions, 4.7 Moisture Sensitivity Level (MSL)).

1 Overview

## 1.1 Introduction

**[0056]** The QT102 is a single key device featuring a touch on / touch off (toggle) output with a programmable auto switch-off capability.

**[0057]** The QT102 is a digital burst mode charge-transfer (QT) sensor designed specifically for touch controls; it includes hardware and signal processing functions to provide stable sensing under a wide variety of changing conditions. In examples, low cost, non-critical components are employed for configuring operation.

**[0058]** The QT102 employs bursts of charge-transfer cycles to acquire its signal. Burst mode permits power consumption in the microampere range, dramatically reduces radio frequency (RF) emissions, lowers susceptibility to electromagnetic interference (EMI), and yet permits good response time. Internally the signals are digitally processed to reject impulse noise, using a 'consensus' filter which in this example requires four consecutive confirmations of a detection before the output is activated.

**[0059]** The QT switches and charge measurement hardware functions are all internal to the QT102.

## 1.2 Electrode Drive

**[0060]** Figure 1 schematically shows the sense electrode connections (SNS, SNSK) for the QT102.



**[0061]** For improved noise immunity, it may be helpful if the electrode is only connected to the SNSK pin.

**[0062]** In examples the sample capacitor  $C_s$  may be much larger than the load capacitance ( $C_x$ ). E.g. typical values for  $C_x$  are 5 to 20pF while  $C_s$  is usually 1 or 2 to 50nF. (Note:  $C_x$  is not a physical discrete component on the PCB, it is the capacitance of the touch electrode and wiring. It is shown in Figure 1 to aid understanding of the equivalent circuit.)

**[0063]** Increasing amounts of  $C_x$  destroy gain, therefore it is important to limit the amount of load capacitance on both SNS terminals. This can be done, for example, by minimizing trace lengths and widths and keeping these traces away from power or ground traces or copper pours.

**[0064]** The traces and any components associated with SNS and SNSK will become touch sensitive and so may need to be considered to help in limiting the touch-sensitive area to the desired location.

**[0065]** A series resistor,  $R_s$ , may be placed in line with SNSK to the electrode to suppress electrostatic discharge (ESD) and Electromagnetic Compatibility (EMC) effects.

### 1.3 Sensitivity

#### 1.3.1 Introduction

**[0066]** The sensitivity of the QT102 is a function of such things as:

- the value of  $C_s$

- electrode size and capacitance
- electrode shape and orientation
- the composition and aspect of the object to be sensed
- the thickness and composition of any overlaying panel material
- the degree of ground coupling of both sensor and object

### 1.3.2 Increasing Sensitivity

**[0067]** In some cases it may be desirable to increase sensitivity; for example, when using the sensor with very thick panels having a low dielectric constant. Sensitivity can often be increased by using a larger electrode or reducing panel thickness. Increasing electrode size can have diminishing returns, as high values of  $C_x$  will reduce sensor gain.

**[0068]** The value of  $C_s$  also has an effect on sensitivity, and this can be increased in value with the trade-off of slower response time and more power. Increasing the electrode's surface area will not substantially increase touch sensitivity if its diameter is already significantly larger in surface area than the object being detected. Panel material can also be changed to one having a higher dielectric constant, which will better help to propagate the field.

**[0069]** Ground planes around and under the electrode and its SNSK trace may lead to high  $C_x$  loading and destroy gain. Thus in some cases the possible signal-to-noise ratio benefits of ground areas may be more than negated by the decreased gain from the circuit, and so ground areas around electrodes may be discouraged in some circumstances. Metal areas near the electrode may reduce

the field strength and increase Cx loading and so it may be helpful if these are avoided if possible. It may be helpful to keep ground away from the electrodes and traces.

#### 1.4 Recalibration Timeout

**[0070]** If an object or material obstructs the sense electrode the signal may rise enough to create a detection, preventing further operation. To help reduce the risk of this, the sensor includes a timer which monitors detections. If a detection exceeds the timer setting (known as the Max On-duration) the sensor performs a full recalibration. This does not toggle the output state but ensures that the QT102 will detect a new touch correctly. The timer is set to activate this feature after ~ 30 seconds. This will vary slightly with Cs.

#### 1.5 Forced Sensor Recalibration

**[0071]** The QT102 has no recalibration pin; a forced recalibration is accomplished when the device is powered up, after the recalibration timeout or when the auto-off override is released.

**[0072]** However, supply drain is low so it is a simple matter to treat the entire IC as a controllable load; driving the QT102's VDD pin directly from another logic gate or a microcontroller port will serve as both power and 'forced recal(ibration)'. The source resistance of most CMOS gates and microcontrollers are low enough to provide direct power without problems.

## 1.6 Drift Compensation

**[0073]** Signal drift can occur because of changes in Cx and Cs over time. It may be helpful if drift is compensated for, otherwise false detections, nondetections, and sensitivity shifts may follow.

**[0074]** Drift compensation is schematically shown in Figure 2. Drift compensation is performed by making a reference level track the raw signal at a slow rate, but only while there is no detection in effect. It may be helpful if the rate of adjustment is performed relatively slowly, otherwise there may be a risk that legitimate detections may be ignored. The QT102 drift compensates using a slew-rate limited change to the reference level; the threshold and hysteresis values are slaved to this reference.

**[0075]** Once an object is sensed, the drift compensation mechanism ceases since the signal is legitimately high, and therefore should not cause the reference level to change (as indicated in Figure 2 during the period between the vertical dotted lines).

**[0076]** The QT102's drift compensation is 'asymmetric'; the reference level drift-compensates in one direction faster than it does in the other. Specifically, it compensates faster for decreasing signals than for increasing signals. It may be helpful if increasing signals are not compensated for quickly, since an approaching finger could be compensated for partially or entirely before approaching the sense electrode.

**[0077]** However, an obstruction over the sense pad, for which the sensor has already made full allowance, could suddenly be removed leaving the sensor with an artificially elevated reference level and thus become insensitive to

touch. In this latter case, the sensor will compensate for the object's removal more quickly, for example in only a few seconds.

**[0078]** With relatively large values of Cs and small values of Cx, drift compensation will appear to operate more slowly than with the converse. Note that the positive and negative drift compensation rates are different.

### 1.7 Response Time

**[0079]** The QT102's response time is dependent on burst length, which in turn is dependent on Cs and Cx. With increasing Cs, response time slows, while increasing levels of Cx reduce response time.

### 1.8 Spread Spectrum

**[0080]** The QT102 modulates its internal oscillator by  $\pm 7.5$  percent during the measurement burst. This spreads the generated noise over a wider band reducing emission levels. This also reduces susceptibility since there is no longer a single fundamental burst frequency.

## 2 Wiring and Parts

**[0081]** Figure 3 schematically shows a basic circuit configuration for an implementation of an embodiment of the invention.

## 2.1 Application Note

**[0082]** Although not directly relevant for embodiments of the invention, for completeness, reference may be made to Application Note AN-KD02 (“Secrets of a Successful QTouch (TM) Design), included herein in its entirety by reference, and downloadable from the Quantum Research Group website, for information on example construction and design methods. Go to <http://www.qprox.com>, click the Support tab and then Application Notes.

## 2.2 Cs Sample Capacitor

**[0083]** Cs is the charge sensing sample capacitor. The required Cs value depends on the thickness of the panel and its dielectric constant. Thicker panels require larger values of Cs. Typical values are 1 or 2 nF to 50nF depending on the sensitivity required; larger values of Cs may demand higher stability and better dielectric to ensure reliable sensing.

**[0084]** The Cs capacitor may be a stable type, such as X7R ceramic or PPS film. For more consistent sensing from unit to unit, 5 percent tolerance capacitors are recommended. X7R ceramic types can be obtained in 5 percent tolerance for little or no extra cost. In applications where high sensitivity (long burst length) is required, the use of PPS capacitors is recommended.

## 2.3 Rs Resistor

**[0085]** Series resistor  $R_s$  is in line with the electrode connection and may be used to limit electrostatic discharge (ESD) currents and to suppress radio frequency interference (RFI). It may be approximately  $4.7k\Omega$  to  $33k\Omega$ , for example.

**[0086]** Although this resistor may be omitted, the device may become susceptible to external noise or RFI. For more details of how to select these resistors see the Application Note AN-KD02 referred to above in Section 2.1.

## 2.4 Power Supply, PCB Layout

**[0087]** The power supply (between VDD and VSS / system ground) can range between 2.0V and 5.5V for the QT102 implementation. If the power supply is shared with another electronic system, it may be helpful if care is taken to ensure that the supply is free of digital spikes, sags, and surges which can adversely affect the device. The QT102 will track slow changes in VDD, but it may be more affected by rapid voltage fluctuations. Thus it may be helpful if a separate voltage regulator is used just for the QT102 to isolate it from power supply shifts caused by other components.

**[0088]** If desired, the supply can be regulated using a Low Dropout (LDO) regulator. See Application Note AN-KD02 (see Section 2.1) for further information on power supply considerations.

**[0089]** Suggested regulator manufacturers include:

- Toko (XC6215 series)

- Seiko (S817 series)
- BCDSemi (AP2121 series)

**[0090]** Parts placement: The chip may be placed to minimize the SNSK trace length to reduce low frequency pickup, and to reduce Cx which degrades gain. It may be helpful if the Cs and Rs resistors (see Figure 3) are placed close to the body of the chip so that the trace between Rs and the SNSK pin is relatively short, thereby reducing the antenna-like ability of this trace to pick up high frequency signals and feed them directly into the chip. A ground plane can be used under the chip and the associated discretes, but it may be helpful if the trace from the Rs resistor and the electrode do not run near ground, to reduce loading.

**[0091]** For improved Electromagnetic compatibility (EMC) performance the circuit may be made entirely with surface mount technology (SMT) components.

**[0092]** Electrode trace routing: It may be helpful to keep the electrode trace (and the electrode itself) away from other signal, power, and ground traces including over or next to ground planes. Adjacent switching signals can induce noise onto the sensing signal; any adjacent trace or ground plane next to, or under, the electrode trace will cause an increase in Cx load and desensitize the device.

**[0093]** Note: a 100nF (0.1  $\mu$ F) ceramic bypass capacitor (not shown in Figure 3) might be used between VDD and VSS in cases where it is considered appropriate to help avoid latch-up if there are substantial VDD transients; for example, during an ESD (electrostatic discharge) event. It may furthermore be helpful if the bypass capacitor is placed close to the device's power pins.



Table 2.1 QT102 Pin Descriptions (referring to the pin numbering shown in Figure 3)

PIN	NAME	TYPE	DESCRIPTION
1	OUT	O	To switched circuit and output polarity selection resistor (R <sub>op</sub> )
2	VSS	P	Ground power pin
3	SNSK	IO	To C <sub>s</sub> capacitor and to sense electrode
4	SNS	IO	To C <sub>s</sub> capacitor and multiplier configuration resistor (R <sub>m</sub> ). R <sub>m</sub> connected to either VSS or VDD. Refer to Section 3.5 for details.
5	VDD	P	Positive power pin
6	TIME	I	Timeout configuration pin, connected to either VSS, VDD, OUT or an RC network. Refer to Section 3.5 for details.

Type: P - Ground or power; IO - Input and output; OD - Open drain output; O - Output only, push-pull; I - Input only

**[0094]** Regarding Figure 3, the following sections provide guidance for some example component values: Section 2.2 for C<sub>s</sub> capacitor (C<sub>s</sub>); Section 2.3 for Sample resistor (R<sub>s</sub>); Section 2.4 for Voltage levels; Section 3.5.2 for R<sub>m</sub>; and Section 3.3 for R<sub>op</sub>.

### 3 Operation

#### 3.1 Acquisition Modes

##### 3.1.1 Introduction

**[0095]** The polarity for the OUT pin of the QT102 can be configured to be “active high” or “active low” (see Section 3.3). If configured active high, then ‘on’ is high and ‘off’ is low. If configured active low, then ‘on’ is low and ‘off’ is high.

**[0096]** The QT102 has more than one acquisition mode with the mode depending on the state of the OUT pin (on or off) and whether a touch is detected. In the following text 'on' is when the output is in its active state (which could be high or low depending on how the polarity for the OUT pin is configured).

### 3.1.2 OUT Pin 'On' (Fast Mode)

**[0097]** The QT102 runs in a "Fast mode" when the OUT pin is on. In this mode the device runs at maximum speed at the expense of increased current consumption. The delay between bursts in Fast mode is approximately 2.6ms. Figure 4 schematically shows bursts on the SNSK pin during fast mode acquisition.

### 3.1.3 OUT Pin 'Off' (Low Power Mode)

**[0098]** The QT102 runs in Low Power (LP) mode if the OUT pin is off. In this mode it sleeps for approximately 85ms at the end of each burst, saving power but slowing response. On detecting a possible key touch, it temporarily switches to Fast mode until either the key touch is confirmed or found to be spurious (via the detect integration process). If the touch is confirmed the QT102 will switch to Fast mode. If a touch is denied the device will revert to normal LP mode operation automatically. Figure 5 schematically shows bursts on the SNSK pin during a touch detection event. Also schematically represented is the output signal on the OUT pin. A key touch occurs around halfway along

the figure. Prior to the key touch, the OUT pin is off (schematically shown here as a low logic level) and the QT102 is running in Low Power mode with sleep periods between bursts. The capacitance measured during the first burst after the key touch is higher and this triggers Fast mode acquisition. Following four burst in which the higher capacitance is seen (see Section 3.2.1), the OUT pin switches to on (schematically shown here as a high logic level) and Fast mode acquisition continues.

## 3.2 Signal Processing

### 3.2.1 Detect Integrator

**[0099]** It is desirable to suppress detections generated by electrical noise or from quick brushes with an object. To accomplish this, the QT102 incorporates a 'detect integration' (DI) counter that increments with each detection until a limit is reached, after which the output is activated. If no detection is sensed prior to the final count, the counter is reset immediately to zero. In the QT102, the required count is four. The DI can also be viewed as a 'consensus' filter, that requires four successive detections to create an output.

### 3.2.2 Detect Threshold

**[0100]** The device detects a touch when the signal has crossed a threshold level. in this example the threshold level is fixed at 10 counts.

### 3.3 Output Polarity Selection

**[0101]** The output (OUT pin) of the QT102 can be configured to have an active high or active low output by means of the output configuration resistor  $R_{op}$ . The resistor is connected between the output and an output configuration voltage  $V_{op}$ , which may be either VSS or VDD as schematically shown in Figure 6. For the QT102, if  $V_{op}$  is VSS, the output polarity is configured active high. If  $V_{op}$  is VDD, the output polarity is configured active low.

**[0102]** It is noted that some devices, such as Digital Transistors, have an internal biasing network that will naturally pull the OUT pin to its inactive state. If these are being used then the resistor  $R_{op}$  is not required, as schematically shown in Figure 7.

### 3.4 Output Drive

**[0103]** The OUT pin in the QT102 embodiment can sink or source up to 2mA. When a relatively large value of  $C_s$  (e.g. >20nF) is used, it may be helpful if the OUT pin current is limited to <1 mA to reduce the risk of gain-shifting side effects. These may happen when the load current creates voltage drops on the die and bonding wires; in some cases these small shifts can materially influence the signal level to cause detection instability.

### 3.5 Auto Off Delay

#### 3.5.1 Introduction

**[0104]** In addition to toggling the output on/off with key touch, the QT102 can automatically switch the output off after a specific time. This feature can be used to save power in situations where the switched device could be left on inadvertently.

**[0105]** The QT102 has:

- three predefined delay times (Section 3.5.2)
- the ability to set a user-programmed delay (Section 3.5.3)
- the ability to override the auto off delay (Section 3.5.4)

**[0106]** The QT102 chip is programmed such that the TIME and SNS pins may be used to configure the auto-off delay  $t_o$  and may be connected in one of the ways described in Sections 3.5.2, 3.5.3 and 3.5.4 to provide different functionality.

### 3.5.2 Auto Off - Predefined Delay

**[0107]** To configure a predefined delay  $t_o$  the TIME pin may be wired to a voltage  $V_t$ , as schematically indicated in Figure 8. Voltage  $V_t$  may be VSS, VDD or OUT. These provides nominal values of  $t_o = 15$  minutes, 60 minutes or infinity (remains on until toggled off) as indicated in Table 3.2 for an active high output configuration and in Table 3.3 for an active low output configuration .

**[0108]** Furthermore, also as shown in Figure 8, a resistor  $R_m$  (e.g. a 1 M $\Omega$  resistor) may be connected between the SNS pin and the logic level  $V_m$  to

provide three auto off functions: namely delay multiplication, delay override and delay retriggering. On power-up the logic level at Vm is assessed and a delay multiplication factor is set to x1 or x24 accordingly (see Table 3.4). At the end of each acquisition cycle the logic level of Vm is monitored to see if an Auto off delay override is required (see Section 3.5.4).

**[0109]** Setting the delay multiplier to x24 will decrease the key sensitivity. Thus in some cases it may be appropriate to compensate for this by increasing the value of Cs.

Table 3.2 Predefined Auto-off Delay  
(Active High Output)

Vt	Auto-off delay (t <sub>o</sub> )
VSS	Infinity (remain on until toggled to off)
VDD	15 minutes
OUT	60 minutes

Table 3.3 Predefined Auto-off Delay  
(Active Low Output)

Vt	Auto-off delay (t <sub>o</sub> )
VSS	15 minutes
VDD	Infinity (remain on until toggled to off)
OUT	60 minutes

Table 3.4 Auto-off Delay Multiplier

Vm	Auto-off delay multiplier
VSS	t <sub>o</sub> * 1
VDD	t <sub>o</sub> * 24

### 3.5.3 Auto Off - User-programmed Delay

**[0110]** If a user-programmed delay is desired, a resistor  $R_t$  and capacitor  $C_t$  can be used to set an auto-off delay (see Table 3.5 and Figure 9). The delay time is dependent on the RC time constant ( $R_t * C_t$ ) the output polarity (i.e. whether active high or active low), and the supply voltage. Section 3.5.5 gives more details of how to configure the QT102 to have auto-off delay times ranging from 1 minute to up to 24 hours.

Table 3.5 Programmable Auto Off Delay

<b>Output type</b>	<b>Auto Off Delay (seconds)</b>
Active high	$(R_t * C_t * 15) / 42$
Active low	$(R_t * C_t * 15) / 14.3$

**[0111]** Notes: The RC divisor values K (42 and 14.3) may be obtained from Figures 13 and 14. In this example the values are for a supply voltage  $V_{DD} = 3.5$  volts. For the parameterization shown in Table 3.5,  $R_t$  is in  $k\Omega$  and  $C_t$  is in nF.

### 3.5.4 Auto Off - Overriding the Auto Off Delay

[0112] In normal operation the QT102 output is turned off automatically after the auto-off delay. However, in some applications it may be useful to extend the auto-off delay ('sustain' function), or to switch the output off immediately ('cancel' function). This can be achieved by pulsing the voltage on the delay multiplier resistor  $R_m$  as schematically shown in Figure 10 (positive-going pulse from VSS to VDD for delay multiplier  $\times 1$  configuration) and Figure 11 (negative-going pulse from VDD to VSS for delay multiplier  $\times 24$  configuration). The pulse duration  $t_p$  may determine whether a retrigger of the auto-off delay or a switch of the output to off is desired. To help ensure the pulse is detected it may be present for a time greater than the burst length as shown in Table 3.6.

Table 3.6 Time Delay Pulse

Pulse Duration	Action
$t_p > \text{burst time} + 10\text{ms}$ (typical value 25ms)	Retrigger (reload auto-off delay counter)
$t_p > \text{burst time} + 50\text{ms}$ (typical value 65ms)	Switch output to off state and inhibit further touch detection until $V_m$ returns to original state

[0113] While  $V_m$  is held in the override state (i.e. the duration of the pulse) the QT102 inhibits bursts and waits for  $V_m$  to return to its original state (at the end of the pulse). When  $V_m$  returns to its original state the QT102 performs a sensor recalibration before continuing in its current output state.

[0114] Figure 12 schematically shows override pulses being applied to a QT102 with delay multiplier set to  $\times 1$  (i.e.  $V_m$  normally at VSS with positive going pulses). The QT102 OUT signal is shown at the top of the Figure.  $V_m$  is shown in the middle. Acquisition bursts on SNSK are shown at the bottom. Each short pulse P on  $V_m$  causes a sensor recalibration C and a restart of the auto-off timer. During the long pulse applied to  $V_m$  (i.e. where  $t_p > t_{off}$ ), the output is



switched off at O. When the pulse finishes, the output remains switched off and a sensor recalibration C is performed.

### 3.5.5 Configuring the User-programmed Auto-off Delay

**[0115]** As described in Section 3.5.3 the QT102 can be configured to give auto-off delays ranging from minutes to hours by means of a simple CR network and the delay multiplier input.

**[0116]** With the delay multiplier set at x1 the auto-off delay is calculated as follows:

Delay value = integer value of  $(Rt * Ct / K) * 15$  seconds.

(i.e.  $Rt * Ct = \text{Delay value (in seconds)} * K / 15$ )

Note:  $Rt$  is in  $k\Omega$ ,  $Ct$  is in nF.

**[0117]** In some applications improved operation may be achieved if the value of  $Rt * Ct$  is between 4 and 240. Values outside this range may be interpreted as the hard wired options TIME linked to OUT and TIME linked to 'off' respectively, causing the QT102 to use the relevant predefined auto-off delays (see Tables 3.2 and 3.3).

**[0118]** Figures 13 and 14 show typical values of K versus supply voltage for a QT102 with active high or active low output.

Example using the formula to calculate  $Rt$  and  $Ct$

**[0119]** Requirements / operating parameters:

- Active high output (Vop connected to VSS)
- Auto-off delay 45 minutes
- VDD = 3.5v

**[0120]** Proceed as follows:

1. Calculate Auto-off delay in seconds  $45 * 60 = 2700$
2. Obtain K from Figure 13 (active high):  $K = 42$  for VDD = 3.5v
3. Calculate  $Rt * Ct = 2700 * 42 / 15 = 7560$
4. Select a value for Ct (or conversely Rt). E.g.  $Ct = 47nF$
5. Calculate Rt (or conversely Ct)  $= 7560 / 47 = 160k\Omega$

**[0121]** As an alternative to calculation, Rt and Ct values may be selected from pre-calculated curves such as shown in Figures 15 and 16. Figures 15 and 16 show charts of typical curves of auto-off delay against resistor and capacitor values for active high (Figure 15) and active low (Figure 16) outputs at various values of VDD and for delay multiplier = x1.

Example using plot shown in Figure 15 or 16 to calculate Rt and Ct

**[0122]** Requirements / operating parameters:

- Active low output (Vop connected to VSS)
- Auto-off delay 10 hours
- VDD = 4V

**[0123]** Proceed as follows:

1. Calculate Auto-off delay in seconds  $10 \times 60 \times 60 = 36000$ . This value is outside of the range of the charts so use the x24 multiplier (connect Rm to VDD).

Note: this will decrease the key sensitivity, so in some circumstances it may be helpful to increase the value of Cs.

2. Find  $36000 / 24 = 1500$  on the 4V chart in Figure 16

3. Read across to see appropriate Rt / Ct combinations. This example shows the following Rt / Ct combinations to be appropriate: 100nF / 10k $\Omega$ , 47nF / 27k $\Omega$ , 22nF / 60k $\Omega$  and 10nF / 130k $\Omega$ .

**[0124]** Of course the Auto-off delay times given here are nominal and will vary slightly from chip to chip and with capacitor and resistor tolerance.

### 3.6 Examples of Typical Applications

**[0125]** Figure 17 shows a first example application of a QT102 chip in accordance with an embodiment of the invention. Here the QT102 is in an active low configuration and is shown driving a PNP transistor with an auto off time of 500s x24 (3.33 hours)

**[0126]** The auto off time for the circuit configuration shown in Figure 16 may be obtained from the VDD = 3V chart in Figure 16. Setting the delay multiplier to x24 will decrease the key sensitivity, so it may be helpful in some cases to increase the value of Cs.

**[0127]** Figure 17 shows a second example application of a QT102 chip in accordance with an embodiment of the invention. Here the QT102 is in an active high configuration and is shown driving high impedance with an auto off time of 135s x 1 (2.25 minutes).

**[0128]** The auto off time for the circuit configuration shown in Figure 18 may be obtained from the VDD = 5V chart in Figure 15.

#### 4. Example Specifications for an example QT102 chip

**[0129]** A chip incorporating an embodiment of the invention may have the following specifications.

##### 4.1 Suggested Maximum Operating Specifications

**[0130]** Operating temperature: -40°C to +85°C

Storage temperature: -55°C to +125°C

VDD: 0 to +6.5V

Maximum continuous pin current, any control or drive pin: ±20mA

Short circuit duration to VSS, any pin: infinite

Short circuit duration to VDD, any pin: infinite

Voltage forced onto any pin: -0.6 to (VDD + 0.6) Volts

#### 4.2 Recommended Typical Operating Conditions

[0131] VDD: +2.0 to 5.5V

Short-term supply ripple+noise:  $\pm 5\text{mV}$

Long-term supply stability:  $\pm 100\text{mV}$

Cs value: 1 or 2 nF to 50nF

Cx value: 5 to 20pF

#### 4.3 AC Specifications

[0132] VDD = 3.0V, Cs = 10nF, Cx = 5pF, Ta = recommended range, unless otherwise noted

Parameter	Description	Min	Typ	Max	Units	Notes
T <sub>RC</sub>	Recalibration time		250		ms	Cs and Cx dependent
T <sub>PC</sub>	Charge duration		2		$\mu\text{s}$	$\pm 7.5\%$ spread spectrum variation
T <sub>PT</sub>	Transfer duration		2		$\mu\text{s}$	$\pm 7.5\%$ spread spectrum variation

$T_{G1}$	Time between end of burst and start of the next (Fast mode)		2.6		ms	
$T_{G2}$	Time between end of burst and start of the next (LP mode)		85		ms	Increases with reducing VDD
$T_{BL}$	Burst length		20		ms	VDD, Cs and Cx dependent. See Section 2.2 for capacitor selection.
$T_R$	Response time			100	ms	

#### 4.4 Signal Processing

Description	Min	Typ	Max	Units	Notes
Threshold differential		10		counts	
Hysteresis		2		counts	
Consensus filter length		4		samples	
Recalibration timer duration		40		secs	Will vary with VDD

#### 4.5 DC Specifications

[0133] VDD = 3.0V, Cs = 10nF, Cx = 5pF, Ta = recommended range, unless otherwise noted

Parameter	Description	Min	Typ	Max	Units	Notes
V <sub>DD</sub>	Supply voltage	2		5/5.5	V	
I <sub>DD</sub>	Supply current	5		60	μA	Depending on supply and run mode
I <sub>ddl</sub>	Supply current, LP Mode		23 37 90		μA	2V 3V 5V
V <sub>DDS</sub>	Supply turn-on slope	100			V/s	Required for proper start-up
V <sub>IL</sub>	Low input logic level			0.8	V	
V <sub>HL</sub>	High input logic level	2.2			V	
V <sub>OL</sub>	Low output voltage			0.6	V	OUT, 4mA sink
V <sub>OH</sub>	High output voltage	VDD-0.7			V	OUT, 1 mA source
I <sub>IL</sub>	Input leakage current			±1	μA	
C <sub>x</sub>	Load capacitance range	0		100	pF	
A <sub>R</sub>	Acquisition resolution		9	14	bits	

#### 4.6 Mechanical Dimensions

[0134] In one example embodiment a chip implementing the above-described QT102 chip functionality may be provided in an SOT23-6 package type. Referring to Figure 19, the chip may thus have the following dimensions.

Package type: SOT23-6						
Symbol	Millimeters			Inches		
	Min	Max	Notes	Min	Max	Notes
M	2.8	3.10		0.110	0.122	
W	2.6	3.0		0.102	0.118	
Aa	1.5	1.75		0.059	0.069	
H	0.9	1.3		0.035	0.051	
h	0.0	0.15		0	0.006	
D	-	-	0.95 BSC	-	-	0.038 BSC
L	0.35	0.5		0.014	0.02	
E	0.35	0.55		0.014	0.022	
e	0.09	0.2		0.004	0.008	
Φ	0°	10°		0°	10°	

[0135] A QT102 chip provided in an SOT23-6 package type may have a pin arrangement as schematically indicated in Figure 20.

#### 4.7 Moisture Sensitivity Level (MSL)

[0136] A chip implementing the above-described QT102 chip functionality may be rated as follows:

MSL Rating	Peak Body Temperature	Specifications
MSL1	260°C	IPC/JEDEC J-STD-020C



**[0137]** Thus, in accordance with an embodiment of the invention, the QT102 charge-transfer (QT) touch sensor is a self-contained digital IC capable of detecting near-proximity or touch. It may project a touch or proximity field through any dielectric like glass, plastic, stone, ceramic, and even most kinds of wood. It can also turn small metal-bearing objects into intrinsic sensors, making them responsive to proximity or touch. This capability, coupled with its ability to self calibrate, can lead to entirely new product concepts. It may be implemented in human interfaces, like control panels, appliances, toys, lighting controls, or anywhere a mechanical switch or button may be found.

**[0138]** The QT102 example embodiment may be seen as a single key chip combining a touch-on / touch-off toggle mode with timeout and timing override functions, oriented towards power control of small appliances and battery-operated products, for example. With a small low-cost SOT-23 package, this device can suit almost any product needing a power switch or other toggle-mode controlled function.

**[0139]** An environmentally friendly ('green') feature of the QT102 is the timeout function, which can turn off power after a specified time delay ranging from minutes to hours. Furthermore, external 'sustain' and 'cancel' functions permit designs where the timeout needs to be extended further or terminated early. A user's interaction with a product might trigger a 'sustain' input, prolonging the time to shutoff. A safety sensor, such as a tip-over switch on a space heater, can feed the 'cancel' function to terminate early.

**[0140]** The QT102 embodiment of the invention features automatic self-calibration, drift compensation, and spread-spectrum burst modulation. The device can in some cases bring inexpensive, easy-to-implement capacitive touch sensing to all kinds of appliances and equipment, from toys to coffee makers. The small, low cost SOT-23 package lets this unique combination of features reside in almost any product.

**[0141]** The QT102 chip embodying an example of the invention may be summarised as having the following operational features / application parameters:

Number of keys: One touch on/touch off (toggle mode), plus hardware programmable auto switch-off / switch-off delay and external cancel

Technology: Spread-spectrum charge-transfer (direct mode)

Example key outline sizes: 6mm x 6mm or larger (generally panel thickness dependent); widely different sizes and shapes possible

Example electrode design: Solid or ring electrode shapes

PCB Layers required: One

Example electrode materials: Etched copper, silver, carbon, Indium Tin Oxide (ITO), Orgacon (RTM)

Example electrode substrates: PCB, FPCB, plastic films, glass

Example panel materials: Plastic, glass, composites, painted surfaces (including relatively low particle density metallic paints)

Example panel thickness: Up to 50mm glass, 20mm plastic (generally electrode size dependent)

Key sensitivity: Settable via external capacitor

Interface: Digital output, active high or active low (hardware configurable)

Moisture tolerance: Good

Power: 2V ~ 5.5V; drawing , for example, 23 $\mu$ A at 2V

Example package: SOT23-6 (3x3 mm) RoHS compliant

Signal processing: Self-calibration, auto drift compensation, noise filtering

Example Applications: Power switch replacement in countertop appliances, irons, battery powered toys, heaters, lighting controls, automotive interior lighting, commercial and industrial equipment such as soldering stations and cooking equipment

**[0142]** The above-described sensors may be used in apparatus or devices with one touch key or the sensing element of the sensor of an embodiment of the invention may comprise more than one key, for example two, three, or more keys.

## CLAIMS

1. A sensor for determining the presence of an object comprising:
  - a sensing element;
  - a capacitance measurement circuit operable to measure the capacitance of the sensing element; and
  - a control circuit operable to determine whether an object is in proximity with the sensor based on a measurement of the capacitance of the sensing element, the control circuit further being operable to provide an output signal to control a function of an apparatus when it is determined that an object has not been in proximity with the sensor for a predetermined time duration.
2. The sensor of claim 1, wherein the control circuit is configured so that the predetermined time duration is selectable from a number of different predefined time durations.
3. The sensor of claim 2, wherein the control circuit includes a time input terminal and the predetermined time duration is selectable from the number of different predefined time durations according to a voltage applied to the time input terminal.
4. The sensor of claim 2, wherein the control circuit includes a delay multiplier terminal and is configured so that a selected one of the number of

different predefined time durations is multiplied by a multiplication factor according to a voltage applied to the delay multiplier terminal to provide the predetermined time duration.

5. The sensor of claim 1, wherein the control circuit is configured so that the predetermined time duration is programmable by a user to provide a user-selected time duration.

6. The sensor of claim 5, further comprising a resistor-capacitor (RC) network coupled to the control circuit and wherein the predetermined time duration depends on a time constant of the RC network.

7. The sensor of claim 5, wherein the control circuit includes a delay multiplier terminal and is configured so that the user-selected time duration is multiplied by a multiplication factor according to a voltage applied to the delay multiplier terminal to provide the predetermined time duration.

8. The sensor of claim 1, wherein the control circuit is configured such that the provision of the output signal to control a function of an apparatus after the predetermined time duration may be overridden so the output signal is not provided when it is determined that an object has not been in proximity with the sensor for a predetermined time duration.

9. The sensor of claim 8, wherein the control circuit is operable to receive an override pulse and on receipt of the override pulse to retrigger the predetermined time duration to so as to extend the time before the output signal to control a function of an apparatus is provided.

10. The sensor of claim 1, wherein the control circuit is configured such that the provision of the output signal to control a function of an apparatus after the predetermined time duration may be overridden so the output signal is provided before it is determined that an object has not been in proximity with the sensor for a predetermined time duration.

11. The sensor of claim 10, wherein the control circuit is operable to receive an override pulse and on receipt of the override pulse to provide the output signal to control a function of an apparatus.

12. The sensor of claim 1, wherein the sensor is configured to perform a recalibration when the sensor is powered up, when an object is determined to be in proximity with the sensor for more than a timer setting, and / or when an override is released.

13. The sensor of claim 1, wherein the control circuit is configured such that the output signal is toggled between a high state and a low state when an object is determined to be in proximity with the sensor.

14. The sensor of claim 1, wherein the function of an apparatus controlled by the output signal is a switch-off function.

15. The sensor of claim 1, wherein the capacitance measurement circuit employs bursts of charge-transfer cycles to acquire measurements.

16. The sensor of claim 1, wherein the capacitance measurement circuit is configured to operate in one of more than one acquisition modes depending on the output signal.

17. The sensor of claim 16, wherein a one of the more than one acquisition modes is a low-power mode.

18. The sensor of claim 16, wherein a one of the more than one acquisition modes is a fast mode.

19. The sensor of claim 1, wherein the capacitance measurement circuit and the control circuit are comprised in a general purpose microcontroller under firmware control.

20. The sensor of claim 1, wherein the capacitance measurement circuit and the control circuit are comprised within a six-pin integrated circuit chip package.

21. An apparatus comprising a sensor according to claim 1.

22. A method for controlling a function of an apparatus comprising: determining whether an object is in proximity with a sensor based on a measurement of the capacitance of a sensing element and providing an output signal to control the function of the apparatus when it is determined that an object has not been in proximity with the sensor for a predetermined time duration.

23. The method of claim 22, wherein the function of the apparatus controlled by the output signal is a switch-off function.



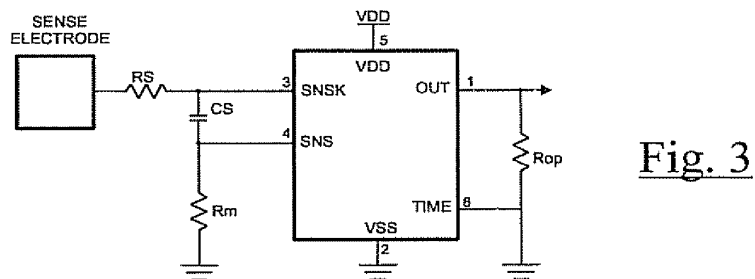
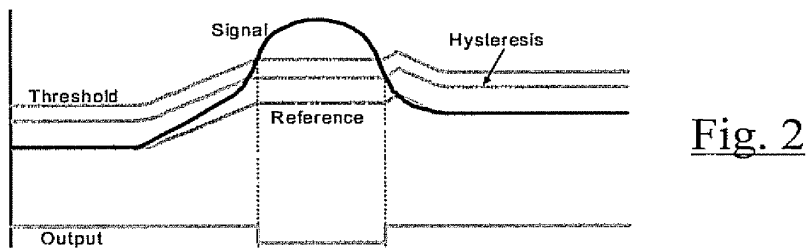
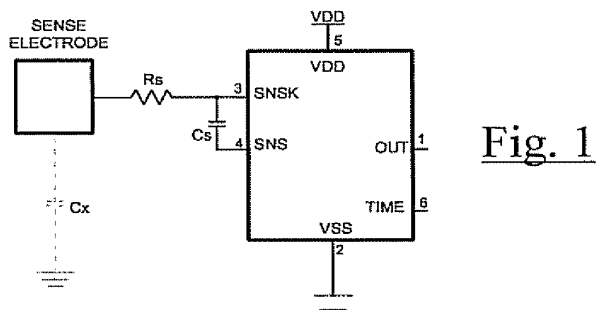

(Output in On condition)

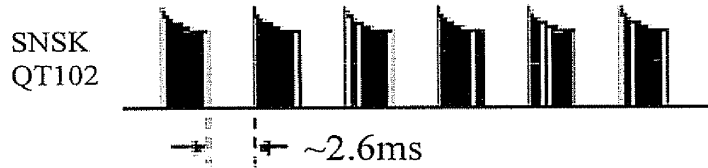

Fig. 4

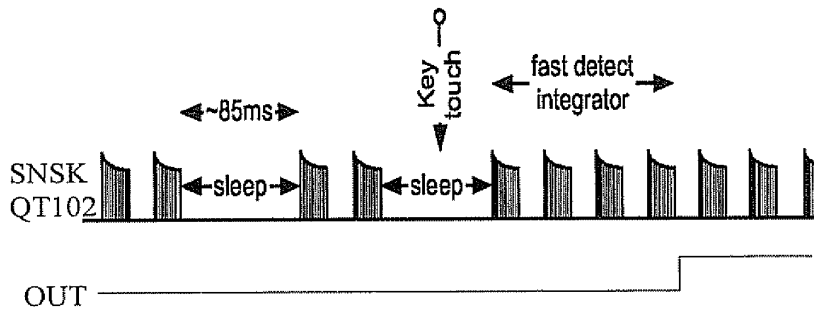

Fig. 5

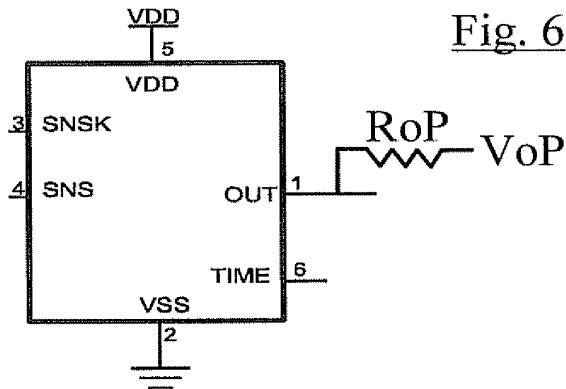

Fig. 6

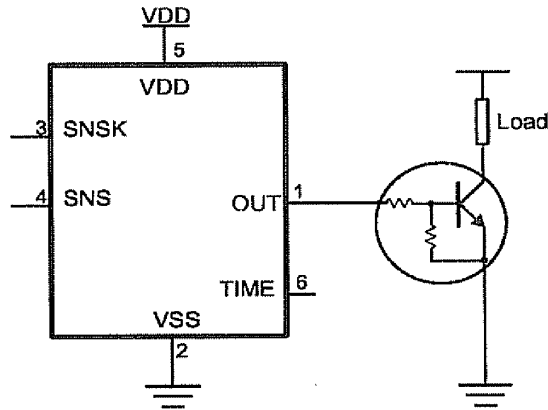

Fig. 7

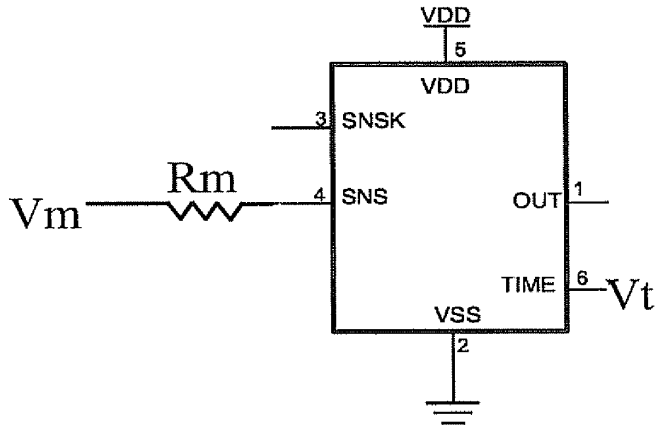

Fig. 8

4/10

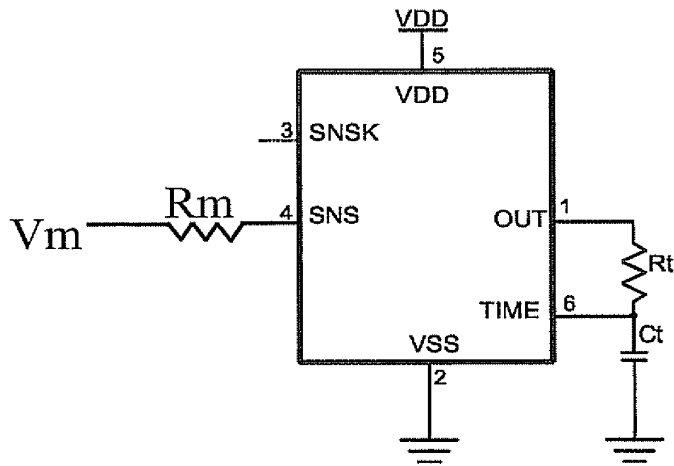

Fig. 9

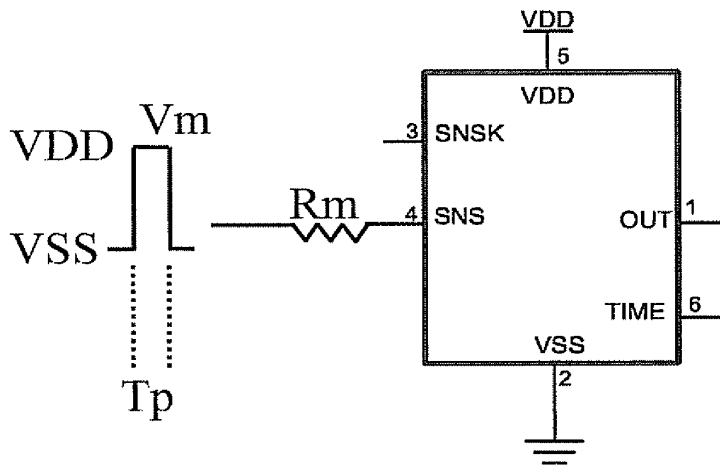

Fig. 10

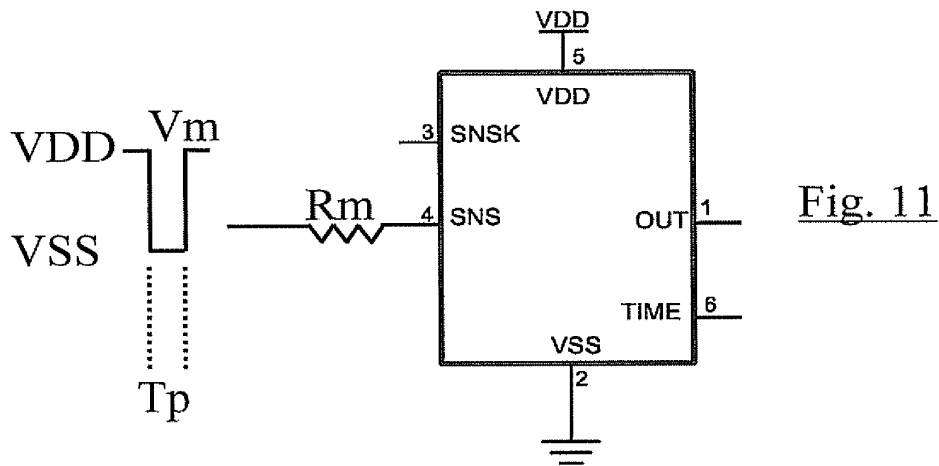

Fig. 11

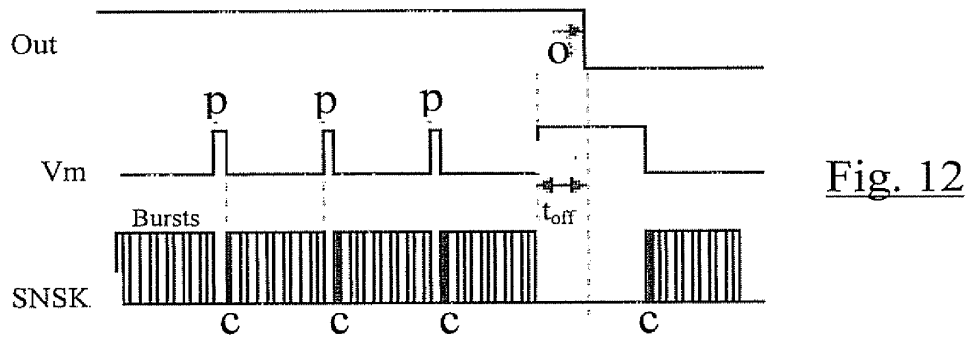

Fig. 12

- P - override (reload auto off delay)
- O - switch output off ( $t_{off}$  burst time + 50ms)
- C - sensor recalibration

### QT102 Active High Output

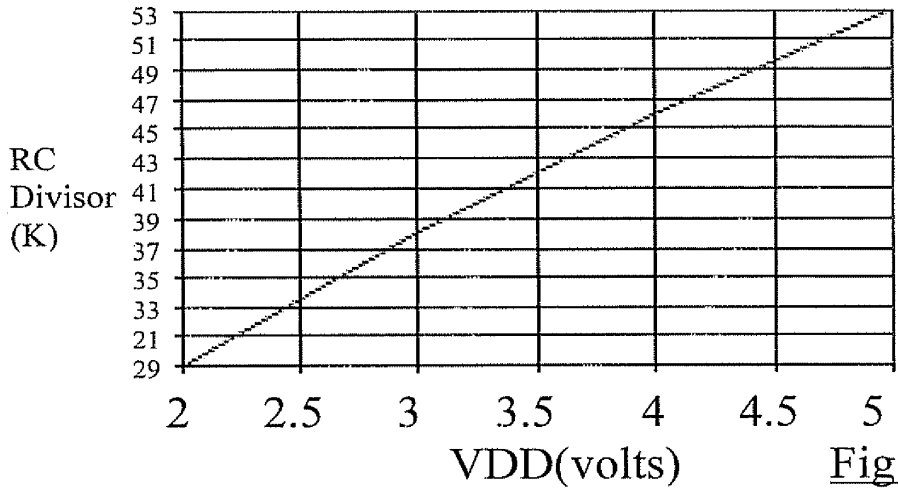

Fig. 13

### QT102 Active Low Output

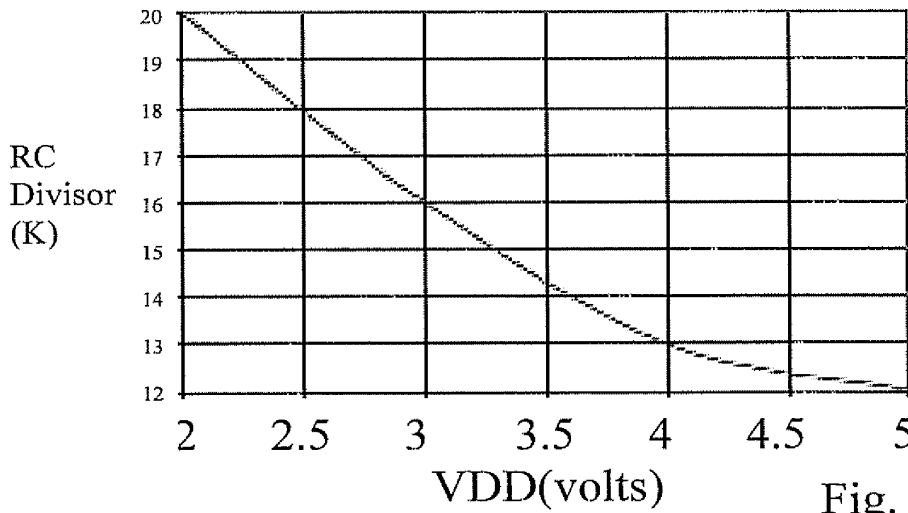

Fig. 14

$V_m = V_{ss}$  (delay multiplier = x1)

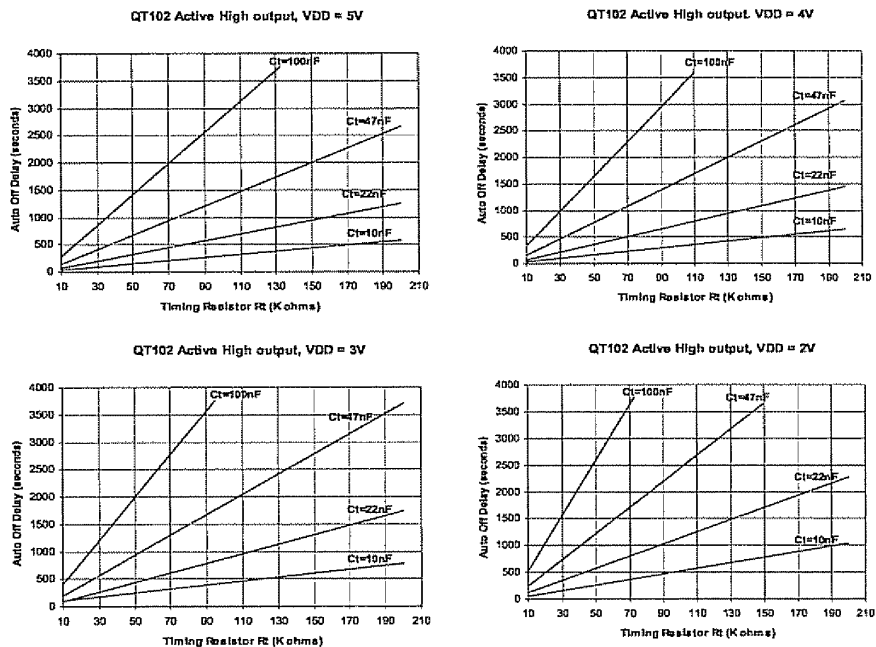

Fig. 15

$V_m = V_{ss}$  (delay multiplier = x1)

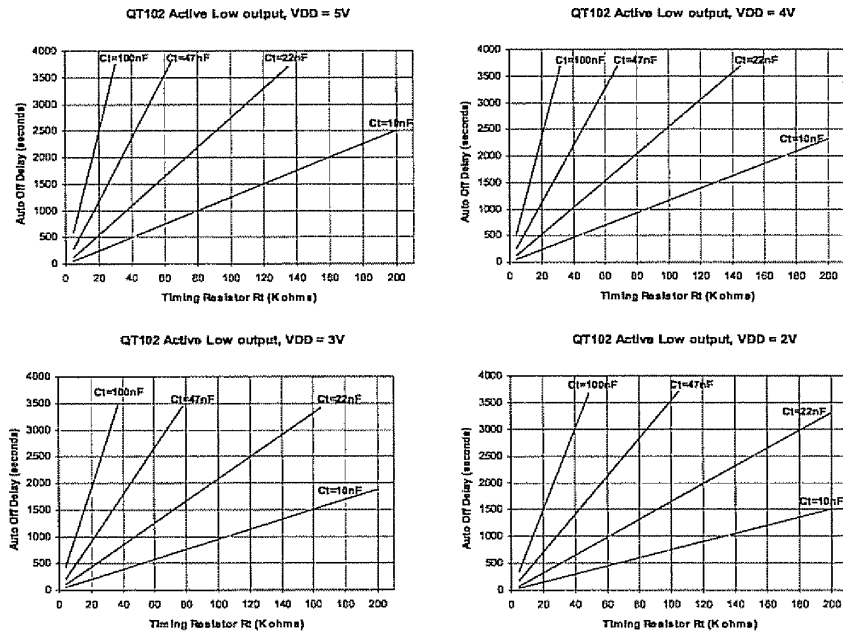

Fig. 16



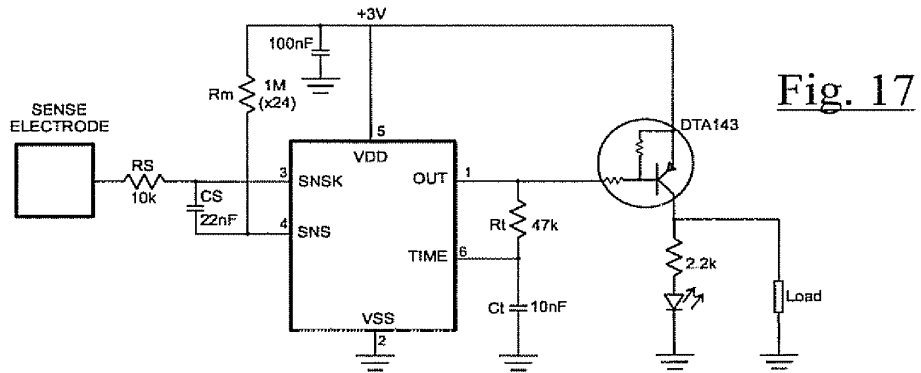

Fig. 17

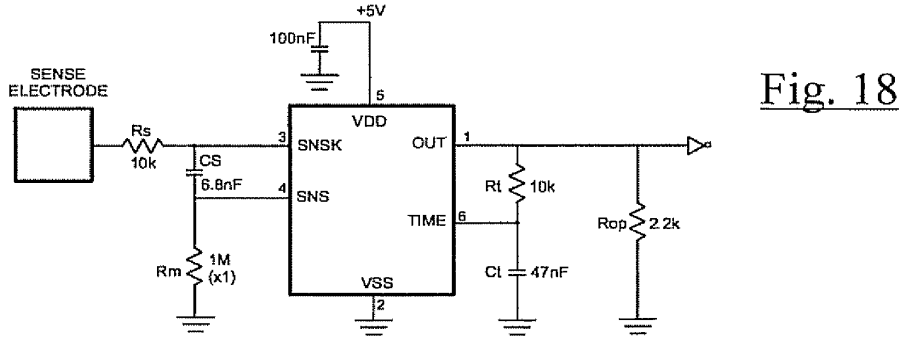
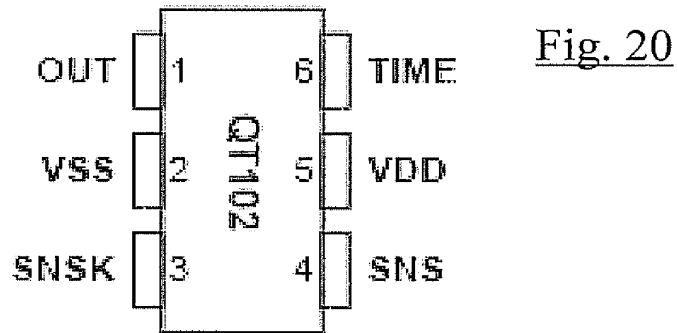
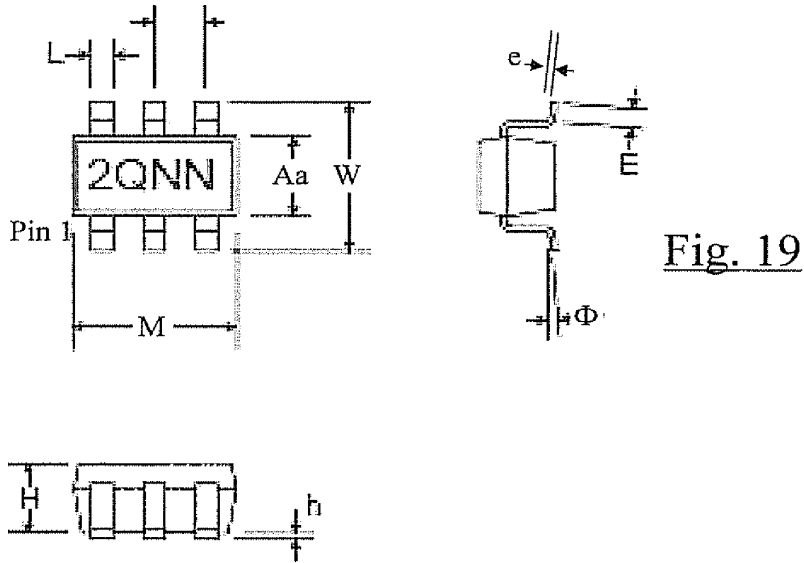

Fig. 18



## Electronic Patent Application Fee Transmittal

<b>Application Number:</b>				
<b>Filing Date:</b>				
<b>Title of Invention:</b>	Proximity Sensor			
First Named Inventor/Applicant Name:	Harald Philipp			
<b>Filer:</b>	David A. Kiewit			
<b>Attorney Docket Number:</b>	QAP			
Filed as Large Entity				
<b>Utility Filing Fees</b>				
<b>Description</b>	<b>Fee Code</b>	<b>Quantity</b>	<b>Amount</b>	<b>Sub-Total in USD(\$)</b>
<b>Basic Filing:</b>				
Utility application filing	1011	1	310	310
Utility Search Fee	1111	1	510	510
Utility Examination Fee	1311	1	210	210
<b>Pages:</b>				
<b>Claims:</b>				
Claims in excess of 20	1202	3	50	150
<b>Miscellaneous-Filing:</b>				
Late filing fee for oath or declaration	1051	1	130	130

Description	Fee Code	Quantity	Amount	Sub-Total in USD(\$)
<b>Petition:</b>				
<b>Patent-Appeals-and-Interference:</b>				
Post-Allowance-and-Post-Issuance:				
<b>Extension-of-Time:</b>				
<b>Miscellaneous:</b>				
<b>Total in USD (\$)</b>				<b>1310</b>

## Electronic Acknowledgement Receipt

<b>EFS ID:</b>	3677497
<b>Application Number:</b>	12179769
<b>International Application Number:</b>	
<b>Confirmation Number:</b>	8745
<b>Title of Invention:</b>	Proximity Sensor
<b>First Named Inventor/Applicant Name:</b>	Harald Philipp
<b>Customer Number:</b>	20191
<b>Filer:</b>	David A. Kiewit
<b>Filer Authorized By:</b>	
<b>Attorney Docket Number:</b>	QAP
<b>Receipt Date:</b>	25-JUL-2008
<b>Filing Date:</b>	
<b>Time Stamp:</b>	13:29:58
<b>Application Type:</b>	Utility under 35 USC 111(a)

### Payment information:

Submitted with Payment	yes
Payment Type	Credit Card
Payment was successfully received in RAM	\$ 1310
RAM confirmation Number	6820
Deposit Account	501012
Authorized User	KIEWIT,DAVID

The Director of the USPTO is hereby authorized to charge indicated fees and credit any overpayment as follows:

Charge any Additional Fees required under 37 C.F.R. Section 1.16 (National application filing, search, and examination fees)

<b>File Listing:</b>					
<b>Document Number</b>	<b>Document Description</b>	<b>File Name</b>	<b>File Size(Bytes) /Message Digest</b>	<b>Multi Part /.zip</b>	<b>Pages (if appl.)</b>
1	Application Data Sheet	qapADS14_fill.pdf	1022879 122fd1344ee59170feca574e9a3303c21d506b1d	no	4
<b>Warnings:</b>					
<b>Information:</b>					
2	Abstract	qapABST.pdf	18966 d223cc815d55eba063d260c9f37fd2914409421	no	1
<b>Warnings:</b>					
<b>Information:</b>					
3	Specification	qapSPEC.pdf	172772 6be59a4d600d29830fd86c7d1ea6971343ee524	no	38
<b>Warnings:</b>					
<b>Information:</b>					
4	Claims	qapCLAIM.pdf	32996 019e1b162918bbc130637ec451c5b41098731ee2	no	5
<b>Warnings:</b>					
<b>Information:</b>					
5	Drawings-only black and white line drawings	qapDWG.PDF	164916 44372d347c22e9a6632bce3c4d736ce3b19584b1	no	10
<b>Warnings:</b>					
<b>Information:</b>					
6	Fee Worksheet (PTO-06)	fee-info.pdf	8516 64b386215a2949941c139c0bd3d7a1b69fa6b31e	no	2
<b>Warnings:</b>					
<b>Information:</b>					
<b>Total Files Size (in bytes):</b>			1421045		

This Acknowledgement Receipt evidences receipt on the noted date by the USPTO of the indicated documents, characterized by the applicant, and including page counts, where applicable. It serves as evidence of receipt similar to a Post Card, as described in MPEP 503.

**New Applications Under 35 U.S.C. 111**

If a new application is being filed and the application includes the necessary components for a filing date (see 37 CFR 1.53(b)-(d) and MPEP 506), a Filing Receipt (37 CFR 1.54) will be issued in due course and the date shown on this Acknowledgement Receipt will establish the filing date of the application.

**National Stage of an International Application under 35 U.S.C. 371**

If a timely submission to enter the national stage of an international application is compliant with the conditions of 35 U.S.C. 371 and other applicable requirements a Form PCT/DO/EO/903 indicating acceptance of the application as a national stage submission under 35 U.S.C. 371 will be issued in addition to the Filing Receipt, in due course.

**New International Application Filed with the USPTO as a Receiving Office**

If a new international application is being filed and the international application includes the necessary components for an international filing date (see PCT Article 11 and MPEP 1810), a Notification of the International Application Number and of the International Filing Date (Form PCT/RO/105) will be issued in due course, subject to prescriptions concerning national security, and the date shown on this Acknowledgement Receipt will establish the international filing date of the application.

<b>INFORMATION DISCLOSURE STATEMENT BY APPLICANT</b> ( Not for submission under 37 CFR 1.99)	Application Number	12179769
	Filing Date	2008-07-25
	First Named Inventor	Philipp
	Art Unit	
	Examiner Name	
	Attorney Docket Number	QAP

U.S.PATENTS							Remove
Examiner Initial*	Cite No	Patent Number	Kind Code <sup>1</sup>	Issue Date	Name of Patentee or Applicant of cited Document	Pages,Columns,Lines where Relevant Passages or Relevant Figures Appear	
	1	5730165	A	1998-03-24	Philipp		
	2	6466036	B1	2002-10-15	Philipp		
	3	6452514	B1	2002-09-17	Philipp		

If you wish to add additional U.S. Patent citation information please click the Add button.

Add

U.S.PATENT APPLICATION PUBLICATIONS							Remove
Examiner Initial*	Cite No	Publication Number	Kind Code <sup>1</sup>	Publication Date	Name of Patentee or Applicant of cited Document	Pages,Columns,Lines where Relevant Passages or Relevant Figures Appear	
	1						

If you wish to add additional U.S. Published Application citation information please click the Add button.

Add

FOREIGN PATENT DOCUMENTS								Remove
Examiner Initial*	Cite No	Foreign Document Number <sup>3</sup>	Country Code <sup>2</sup> j	Kind Code <sup>4</sup>	Publication Date	Name of Patentee or Applicant of cited Document	Pages,Columns,Lines where Relevant Passages or Relevant Figures Appear	T <sup>5</sup>
	1							<input type="checkbox"/>



<b>INFORMATION DISCLOSURE STATEMENT BY APPLICANT</b> ( Not for submission under 37 CFR 1.99)	Application Number	12179769
	Filing Date	2008-07-25
	First Named Inventor	Philipp
	Art Unit	
	Examiner Name	
	Attorney Docket Number	QAP

If you wish to add additional Foreign Patent Document citation information please click the Add button			<input type="button" value="Add"/>
<b>NON-PATENT LITERATURE DOCUMENTS</b>			<input type="button" value="Remove"/>
Examiner Initials*	Cite No	Include name of the author (in CAPITAL LETTERS), title of the article (when appropriate), title of the item (book, magazine, journal, serial, symposium, catalog, etc), date, pages(s), volume-issue number(s), publisher, city and/or country where published.	T <sup>5</sup>
	1		<input type="checkbox"/>
If you wish to add additional non-patent literature document citation information please click the Add button			<input type="button" value="Add"/>
<b>EXAMINER SIGNATURE</b>			
Examiner Signature		Date Considered	
*EXAMINER: Initial if reference considered, whether or not citation is in conformance with MPEP 609. Draw line through a citation if not in conformance and not considered. Include copy of this form with next communication to applicant.			
<sup>1</sup> See Kind Codes of USPTO Patent Documents at <a href="http://www.USPTO.GOV">www.USPTO.GOV</a> or MPEP 901.04. <sup>2</sup> Enter office that issued the document, by the two-letter code (WIPO Standard ST.3). <sup>3</sup> For Japanese patent documents, the indication of the year of the reign of the Emperor must precede the serial number of the patent document. <sup>4</sup> Kind of document by the appropriate symbols as indicated on the document under WIPO Standard ST.16 if possible. <sup>5</sup> Applicant is to place a check mark here if English language translation is attached.			

<b>INFORMATION DISCLOSURE STATEMENT BY APPLICANT</b> ( Not for submission under 37 CFR 1.99)	Application Number	12179769
	Filing Date	2008-07-25
	First Named Inventor	Philipp
	Art Unit	
	Examiner Name	
	Attorney Docket Number	QAP

**CERTIFICATION STATEMENT**

Please see 37 CFR 1.97 and 1.98 to make the appropriate selection(s):

That each item of information contained in the information disclosure statement was first cited in any communication from a foreign patent office in a counterpart foreign application not more than three months prior to the filing of the information disclosure statement. See 37 CFR 1.97(e)(1).

**OR**

That no item of information contained in the information disclosure statement was cited in a communication from a foreign patent office in a counterpart foreign application, and, to the knowledge of the person signing the certification after making reasonable inquiry, no item of information contained in the information disclosure statement was known to any individual designated in 37 CFR 1.56(c) more than three months prior to the filing of the information disclosure statement. See 37 CFR 1.97(e)(2).

See attached certification statement.

Fee set forth in 37 CFR 1.17 (p) has been submitted herewith.

None

**SIGNATURE**

A signature of the applicant or representative is required in accordance with CFR 1.33, 10.18. Please see CFR 1.4(d) for the form of the signature.

Signature	/David A Kiewit/	Date (YYYY-MM-DD)	2008-07-25
Name/Print	David Kiewit	Registration Number	34640

This collection of information is required by 37 CFR 1.97 and 1.98. The information is required to obtain or retain a benefit by the public which is to file (and by the USPTO to process) an application. Confidentiality is governed by 35 U.S.C. 122 and 37 CFR 1.14. This collection is estimated to take 1 hour to complete, including gathering, preparing and submitting the completed application form to the USPTO. Time will vary depending upon the individual case. Any comments on the amount of time you require to complete this form and/or suggestions for reducing this burden, should be sent to the Chief Information Officer, U.S. Patent and Trademark Office, U.S. Department of Commerce, P.O. Box 1450, Alexandria, VA 22313-1450. **DO NOT SEND FEES OR COMPLETED FORMS TO THIS ADDRESS. SEND TO: Commissioner for Patents, P.O. Box 1450, Alexandria, VA 22313-1450.**

## Privacy Act Statement

The Privacy Act of 1974 (P.L. 93-579) requires that you be given certain information in connection with your submission of the attached form related to a patent application or patent. Accordingly, pursuant to the requirements of the Act, please be advised that: (1) the general authority for the collection of this information is 35 U.S.C. 2(b)(2); (2) furnishing of the information solicited is voluntary; and (3) the principal purpose for which the information is used by the U.S. Patent and Trademark Office is to process and/or examine your submission related to a patent application or patent. If you do not furnish the requested information, the U.S. Patent and Trademark Office may not be able to process and/or examine your submission, which may result in termination of proceedings or abandonment of the application or expiration of the patent.

The information provided by you in this form will be subject to the following routine uses:

1. The information on this form will be treated confidentially to the extent allowed under the Freedom of Information Act (5 U.S.C. 552) and the Privacy Act (5 U.S.C. 552a). Records from this system of records may be disclosed to the Department of Justice to determine whether the Freedom of Information Act requires disclosure of these records.
2. A record from this system of records may be disclosed, as a routine use, in the course of presenting evidence to a court, magistrate, or administrative tribunal, including disclosures to opposing counsel in the course of settlement negotiations.
3. A record in this system of records may be disclosed, as a routine use, to a Member of Congress submitting a request involving an individual, to whom the record pertains, when the individual has requested assistance from the Member with respect to the subject matter of the record.
4. A record in this system of records may be disclosed, as a routine use, to a contractor of the Agency having need for the information in order to perform a contract. Recipients of information shall be required to comply with the requirements of the Privacy Act of 1974, as amended, pursuant to 5 U.S.C. 552a(m).
5. A record related to an International Application filed under the Patent Cooperation Treaty in this system of records may be disclosed, as a routine use, to the International Bureau of the World Intellectual Property Organization, pursuant to the Patent Cooperation Treaty.
6. A record in this system of records may be disclosed, as a routine use, to another federal agency for purposes of National Security review (35 U.S.C. 181) and for review pursuant to the Atomic Energy Act (42 U.S.C. 218(c)).
7. A record from this system of records may be disclosed, as a routine use, to the Administrator, General Services, or his/her designee, during an inspection of records conducted by GSA as part of that agency's responsibility to recommend improvements in records management practices and programs, under authority of 44 U.S.C. 2904 and 2906. Such disclosure shall be made in accordance with the GSA regulations governing inspection of records for this purpose, and any other relevant (i.e., GSA or Commerce) directive. Such disclosure shall not be used to make determinations about individuals.
8. A record from this system of records may be disclosed, as a routine use, to the public after either publication of the application pursuant to 35 U.S.C. 122(b) or issuance of a patent pursuant to 35 U.S.C. 151. Further, a record may be disclosed, subject to the limitations of 37 CFR 1.14, as a routine use, to the public if the record was filed in an application which became abandoned or in which the proceedings were terminated and which application is referenced by either a published application, an application open to public inspections or an issued patent.
9. A record from this system of records may be disclosed, as a routine use, to a Federal, State, or local law enforcement agency, if the USPTO becomes aware of a violation or potential violation of law or regulation.

## Electronic Acknowledgement Receipt

<b>EFS ID:</b>	3678129
<b>Application Number:</b>	12179769
<b>International Application Number:</b>	
<b>Confirmation Number:</b>	8745
<b>Title of Invention:</b>	Proximity Sensor
<b>First Named Inventor/Applicant Name:</b>	Harald Philipp
<b>Customer Number:</b>	20191
<b>Filer:</b>	David A. Kiewit
<b>Filer Authorized By:</b>	
<b>Attorney Docket Number:</b>	QAP
<b>Receipt Date:</b>	25-JUL-2008
<b>Filing Date:</b>	
<b>Time Stamp:</b>	14:20:32
<b>Application Type:</b>	Utility under 35 USC 111(a)

### Payment information:

Submitted with Payment	no
------------------------	----

### File Listing:

Document Number	Document Description	File Name	File Size(Bytes) /Message Digest	Multi Part /.zip	Pages (if appl.)
1	Information Disclosure Statement (IDS) Filed	qapIDSForm__SB_08a.pdf	572519 <small>19aa6824d9a80c8310cb8e27000ae848 2a011a71</small>	no	4

### Warnings:

### Information:

This Acknowledgement Receipt evidences receipt on the noted date by the USPTO of the indicated documents, characterized by the applicant, and including page counts, where applicable. It serves as evidence of receipt similar to a Post Card, as described in MPEP 503.

**New Applications Under 35 U.S.C. 111**

If a new application is being filed and the application includes the necessary components for a filing date (see 37 CFR 1.53(b)-(d) and MPEP 506), a Filing Receipt (37 CFR 1.54) will be issued in due course and the date shown on this Acknowledgement Receipt will establish the filing date of the application.

**National Stage of an International Application under 35 U.S.C. 371**

If a timely submission to enter the national stage of an international application is compliant with the conditions of 35 U.S.C. 371 and other applicable requirements a Form PCT/DO/EO/903 indicating acceptance of the application as a national stage submission under 35 U.S.C. 371 will be issued in addition to the Filing Receipt, in due course.

**New International Application Filed with the USPTO as a Receiving Office**

If a new international application is being filed and the international application includes the necessary components for an international filing date (see PCT Article 11 and MPEP 1810), a Notification of the International Application Number and of the International Filing Date (Form PCT/RO/105) will be issued in due course, subject to prescriptions concerning national security, and the date shown on this Acknowledgement Receipt will establish the international filing date of the application.

Filing Date: 07/25/08

Approved for use through 7/31/2006. OMB 0651-0032  
U.S. Patent and Trademark Office; U.S. DEPARTMENT OF COMMERCE

Under the Paperwork Reduction Act of 1995, no persons are required to respond to a collection of information unless it displays a valid OMB control number.

PATENT APPLICATION FEE DETERMINATION RECORD					Application or Docket Number		
Substitute for Form PTO-875					12/179,769		
<b>APPLICATION AS FILED – PART I</b>							
(Column 1)			(Column 2)		SMALL ENTITY		
OR			OTHER THAN SMALL ENTITY				
FOR	NUMBER FILED	NUMBER EXTRA	RATE (\$)	FEE (\$)	RATE (\$)	FEE (\$)	
BASIC FEE (37 CFR 1.16(a), (b), or (c))	N/A	N/A			N/A	310	
SEARCH FEE (37 CFR 1.16(k), (l), or (m))	N/A	N/A	N/A		N/A	510	
EXAMINATION FEE (37 CFR 1.16(o), (p), or (q))	N/A	N/A	N/A		N/A	210	
TOTAL CLAIMS (37 CFR 1.16(i))	23	minus 20 = 3	X\$ 25		X\$50	150	
INDEPENDENT CLAIMS (37 CFR 1.16(h))	2	minus 3 = 0	X\$100		X\$210	0	
APPLICATION SIZE FEE (37 CFR 1.16(s))	If the specification and drawings exceed 100 sheets of paper, the application size fee due is \$250 (\$125 for small entity) for each additional 50 sheets or fraction thereof. See 35 U.S.C. 41(a)(1)(G) and 37 CFR 1.16(s).						
MULTIPLE DEPENDENT CLAIM PRESENT (37 CFR 1.16(j))			185		370		
			TOTAL	0	TOTAL	1180	
* If the difference in column 1 is less than zero, enter "0" in column 2.							
<b>APPLICATION AS AMENDED – PART II</b>							
(Column 1)		(Column 2)		(Column 3)		SMALL ENTITY	
OR		OTHER THAN SMALL ENTITY					
AMENDMENT A	CLAIMS REMAINING AFTER AMENDMENT	HIGHEST NUMBER PREVIOUSLY PAID FOR	PRESENT EXTRA	RATE (\$)	ADDITIONAL FEE (\$)	RATE (\$)	ADDITIONAL FEE (\$)
	Total (37 CFR 1.16(i))	Minus **	=	X =		X =	
	Independent (37 CFR 1.16(h))	Minus ***	=	X =		X =	
	Application Size Fee (37 CFR 1.16(s))			N/A		N/A	
	FIRST PRESENTATION OF MULTIPLE DEPENDENT CLAIM (37 CFR 1.16(j))						
			TOTAL		TOTAL		
			ADD'T FEE		ADD'T FEE		
(Column 1)		(Column 2)		(Column 3)		SMALL ENTITY	
OR		OTHER THAN SMALL ENTITY					
AMENDMENT B	CLAIMS REMAINING AFTER AMENDMENT	HIGHEST NUMBER PREVIOUSLY PAID FOR	PRESENT EXTRA	RATE (\$)	ADDITIONAL FEE (\$)	RATE (\$)	ADDITIONAL FEE (\$)
	Total (37 CFR 1.16(i))	Minus **	=	X =		X =	
	Independent (37 CFR 1.16(h))	Minus ***	=	X =		X =	
	Application Size Fee (37 CFR 1.16(s))			N/A		N/A	
	FIRST PRESENTATION OF MULTIPLE DEPENDENT CLAIM (37 CFR 1.16(j))						
			TOTAL		TOTAL		
			ADD'T FEE		ADD'T FEE		
* If the entry in column 1 is less than the entry in column 2, write "0" in column 3.							
** If the "Highest Number Previously Paid For" IN THIS SPACE is less than 20, enter "20".							
*** If the "Highest Number Previously Paid For" IN THIS SPACE is less than 3, enter "3".							
The "Highest Number Previously Paid For" (Total or Independent) is the highest number found in the appropriate box in column 1.							

This collection of information is required by 37 CFR 1.16. The information is required to obtain or retain a benefit by the public which is to file (and by the USPTO to process) an application. Confidentiality is governed by 35 U.S.C. 122 and 37 CFR 1.14. This collection is estimated to take 12 minutes to complete, including gathering, preparing, and submitting the completed application form to the USPTO. Time will vary depending upon the individual case. Any comments on the amount of time you require to complete this form and/or suggestions for reducing this burden, should be sent to the Chief Information Officer, U.S. Patent and Trademark Office, U.S. Department of Commerce, P.O. Box 1450, Alexandria, VA 22313-1450. DO NOT SEND FEES OR COMPLETED FORMS TO THIS ADDRESS. SEND TO: Commissioner for Patents, P.O. Box 1450, Alexandria, VA 22313-1450.

If you need assistance in completing the form, call 1-800-PTO-9199 and select option 2.



UNITED STATES PATENT AND TRADEMARK OFFICE

UNITED STATES DEPARTMENT OF COMMERCE
United States Patent and Trademark Office
Address: COMMISSIONER FOR PATENTS
P.O. Box 1450
Alexandria, Virginia 22313-1450
www.uspto.gov

Table with 4 columns: APPLICATION NUMBER (12/179,769), FILING OR 371(C) DATE (07/25/2008), FIRST NAMED APPLICANT (Harald Philipp), ATTY. DOCKET NO./TITLE (QAP)

CONFIRMATION NO. 8745

FORMALITIES LETTER



20191
DAVID KIEWIT
5901 THIRD ST SOUTH
ST PETERSBURG, FL 33705

Date Mailed: 08/05/2008

NOTICE TO FILE MISSING PARTS OF NONPROVISIONAL APPLICATION

FILED UNDER 37 CFR 1.53(b)

Filing Date Granted

Items Required To Avoid Abandonment:

An application number and filing date have been accorded to this application. The item(s) indicated below, however, are missing. Applicant is given TWO MONTHS from the date of this Notice within which to file all required items and pay any fees required below to avoid abandonment. Extensions of time may be obtained by filing a petition accompanied by the extension fee under the provisions of 37 CFR 1.136(a).

- The oath or declaration is missing.
A properly signed oath or declaration in compliance with 37 CFR 1.63, identifying the application by the above Application Number and Filing Date, is required.
Note: If a petition under 37 CFR 1.47 is being filed, an oath or declaration in compliance with 37 CFR 1.63 signed by all available joint inventors, or if no inventor is available by a party with sufficient proprietary interest, is required.

The application is informal since it does not comply with the regulations for the reason(s) indicated below.

The required item(s) identified below must be timely submitted to avoid abandonment:

- Replacement drawings in compliance with 37 CFR 1.84 and 37 CFR 1.121(d) are required. The drawings submitted are not acceptable because:
The drawings submitted to the Office are not electronically reproducible because portions of figures 15 & 16 are missing and/or blurry.

Applicant is cautioned that correction of the above items may cause the specification and drawings page count to exceed 100 pages. If the specification and drawings exceed 100 pages, applicant will need to submit the required application size fee.

Replies should be mailed to:

Mail Stop Missing Parts  
Commissioner for Patents  
P.O. Box 1450  
Alexandria VA 22313-1450

Registered users of EFS-Web may alternatively submit their reply to this notice via EFS-Web.  
<https://sportal.uspto.gov/authenticate/AuthenticateUserLocalEPF.html>

For more information about EFS-Web please call the USPTO Electronic Business Center at **1-866-217-9197** or visit our website at <http://www.uspto.gov/ebc>.

If you are not using EFS-Web to submit your reply, you must include a copy of this notice.

/tvo/

---

Office of Data Management, Application Assistance Unit (571) 272-4000, or (571) 272-4200, or 1-888-786-0101





UNITED STATES PATENT AND TRADEMARK OFFICE

UNITED STATES DEPARTMENT OF COMMERCE
United States Patent and Trademark Office
Address: COMMISSIONER FOR PATENTS
PO Box 1450
Alexandria, Virginia 22313-1450
www.uspto.gov

Table with 7 columns: APPLICATION NUMBER, FILING or 371(c) DATE, GRP ART UNIT, FIL FEE REC'D, ATTY.DOCKET.NO, TOT CLAIMS, IND CLAIMS. Row 1: 12/179,769, 07/25/2008, 2878, 1310, QAP, 23, 2

CONFIRMATION NO. 8745

FILING RECEIPT

20191
DAVID KIEWIT
5901 THIRD ST SOUTH
ST PETERSBURG, FL 33705



Date Mailed: 08/05/2008

Receipt is acknowledged of this non-provisional patent application. The application will be taken up for examination in due course. Applicant will be notified as to the results of the examination. Any correspondence concerning the application must include the following identification information: the U.S. APPLICATION NUMBER, FILING DATE, NAME OF APPLICANT, and TITLE OF INVENTION. Fees transmitted by check or draft are subject to collection. Please verify the accuracy of the data presented on this receipt. If an error is noted on this Filing Receipt, please submit a written request for a Filing Receipt Correction. Please provide a copy of this Filing Receipt with the changes noted thereon. If you received a "Notice to File Missing Parts" for this application, please submit any corrections to this Filing Receipt with your reply to the Notice. When the USPTO processes the reply to the Notice, the USPTO will generate another Filing Receipt incorporating the requested corrections

Applicant(s)

Harald Philipp, Southampton, UNITED KINGDOM;
Kevin Snoad, Chicester, UNITED KINGDOM;

Assignment For Published Patent Application

QRG LIMITED, Eastleigh, UNITED KINGDOM

Power of Attorney: None

Domestic Priority data as claimed by applicant

This appln claims benefit of 60/952,053 07/26/2007

Foreign Applications

If Required, Foreign Filing License Granted: 08/01/2008

The country code and number of your priority application, to be used for filing abroad under the Paris Convention, is US 12/179,769

Projected Publication Date: To Be Determined - pending completion of Missing Parts

Non-Publication Request: No

Early Publication Request: No

**Title**

Proximity Sensor

**Preliminary Class**

250

**PROTECTING YOUR INVENTION OUTSIDE THE UNITED STATES**

Since the rights granted by a U.S. patent extend only throughout the territory of the United States and have no effect in a foreign country, an inventor who wishes patent protection in another country must apply for a patent in a specific country or in regional patent offices. Applicants may wish to consider the filing of an international application under the Patent Cooperation Treaty (PCT). An international (PCT) application generally has the same effect as a regular national patent application in each PCT-member country. The PCT process **simplifies** the filing of patent applications on the same invention in member countries, but **does not result** in a grant of "an international patent" and does not eliminate the need of applicants to file additional documents and fees in countries where patent protection is desired.

Almost every country has its own patent law, and a person desiring a patent in a particular country must make an application for patent in that country in accordance with its particular laws. Since the laws of many countries differ in various respects from the patent law of the United States, applicants are advised to seek guidance from specific foreign countries to ensure that patent rights are not lost prematurely.

Applicants also are advised that in the case of inventions made in the United States, the Director of the USPTO must issue a license before applicants can apply for a patent in a foreign country. The filing of a U.S. patent application serves as a request for a foreign filing license. The application's filing receipt contains further information and guidance as to the status of applicant's license for foreign filing.

Applicants may wish to consult the USPTO booklet, "General Information Concerning Patents" (specifically, the section entitled "Treaties and Foreign Patents") for more information on timeframes and deadlines for filing foreign patent applications. The guide is available either by contacting the USPTO Contact Center at 800-786-9199, or it can be viewed on the USPTO website at <http://www.uspto.gov/web/offices/pac/doc/general/index.html>.

For information on preventing theft of your intellectual property (patents, trademarks and copyrights), you may wish to consult the U.S. Government website, <http://www.stopfakes.gov>. Part of a Department of Commerce initiative, this website includes self-help "toolkits" giving innovators guidance on how to protect intellectual property in specific countries such as China, Korea and Mexico. For questions regarding patent enforcement issues, applicants may call the U.S. Government hotline at 1-866-999-HALT (1-866-999-4158).

**LICENSE FOR FOREIGN FILING UNDER****Title 35, United States Code, Section 184****Title 37, Code of Federal Regulations, 5.11 & 5.15****GRANTED**

The applicant has been granted a license under 35 U.S.C. 184, if the phrase "IF REQUIRED, FOREIGN FILING LICENSE GRANTED" followed by a date appears on this form. Such licenses are issued in all applications where the conditions for issuance of a license have been met, regardless of whether or not a license may be required as

page 2 of 3

set forth in 37 CFR 5.15. The scope and limitations of this license are set forth in 37 CFR 5.15(a) unless an earlier license has been issued under 37 CFR 5.15(b). The license is subject to revocation upon written notification. The date indicated is the effective date of the license, unless an earlier license of similar scope has been granted under 37 CFR 5.13 or 5.14.

This license is to be retained by the licensee and may be used at any time on or after the effective date thereof unless it is revoked. This license is automatically transferred to any related applications(s) filed under 37 CFR 1.53(d). This license is not retroactive.

The grant of a license does not in any way lessen the responsibility of a licensee for the security of the subject matter as imposed by any Government contract or the provisions of existing laws relating to espionage and the national security or the export of technical data. Licensees should apprise themselves of current regulations especially with respect to certain countries, of other agencies, particularly the Office of Defense Trade Controls, Department of State (with respect to Arms, Munitions and Implements of War (22 CFR 121-128)); the Bureau of Industry and Security, Department of Commerce (15 CFR parts 730-774); the Office of Foreign AssetsControl, Department of Treasury (31 CFR Parts 500+) and the Department of Energy.

**NOT GRANTED**

No license under 35 U.S.C. 184 has been granted at this time, if the phrase "IF REQUIRED, FOREIGN FILING LICENSE GRANTED" DOES NOT appear on this form. Applicant may still petition for a license under 37 CFR 5.12, if a license is desired before the expiration of 6 months from the filing date of the application. If 6 months has lapsed from the filing date of this application and the licensee has not received any indication of a secrecy order under 35 U.S.C. 181, the licensee may foreign file the application pursuant to 37 CFR 5.15(b).

<b>Electronic Acknowledgement Receipt</b>	
<b>EFS ID:</b>	3869076
<b>Application Number:</b>	12179769
<b>International Application Number:</b>	
<b>Confirmation Number:</b>	8745
<b>Title of Invention:</b>	Proximity Sensor
<b>First Named Inventor/Applicant Name:</b>	Harald Philipp
<b>Customer Number:</b>	20191
<b>Filer:</b>	David A. Kiewit
<b>Filer Authorized By:</b>	
<b>Attorney Docket Number:</b>	QAP
<b>Receipt Date:</b>	31-AUG-2008
<b>Filing Date:</b>	25-JUL-2008
<b>Time Stamp:</b>	20:34:15
<b>Application Type:</b>	Utility under 35 USC 111(a)

**Payment information:**

Submitted with Payment	no
------------------------	----

**File Listing:**

Document Number	Document Description	File Name	File Size(Bytes)/ Message Digest	Multi Part /.zip	Pages (if appl.)
1	Drawings-only black and white line drawings	qapFMLdwdg.pdf	409619 f4881af8243753d1497f6031825c91121c2c02cd	no	10

**Warnings:**

**Information:**

This Acknowledgement Receipt evidences receipt on the noted date by the USPTO of the indicated documents, characterized by the applicant, and including page counts, where applicable. It serves as evidence of receipt similar to a Post Card, as described in MPEP 503.

**New Applications Under 35 U.S.C. 111**

If a new application is being filed and the application includes the necessary components for a filing date (see 37 CFR 1.53(b)-(d) and MPEP 506), a Filing Receipt (37 CFR 1.54) will be issued in due course and the date shown on this Acknowledgement Receipt will establish the filing date of the application.

**National Stage of an International Application under 35 U.S.C. 371**

If a timely submission to enter the national stage of an international application is compliant with the conditions of 35 U.S.C. 371 and other applicable requirements a Form PCT/DO/EO/903 indicating acceptance of the application as a national stage submission under 35 U.S.C. 371 will be issued in addition to the Filing Receipt, in due course.

**New International Application Filed with the USPTO as a Receiving Office**

If a new international application is being filed and the international application includes the necessary components for an international filing date (see PCT Article 11 and MPEP 1810), a Notification of the International Application Number and of the International Filing Date (Form PCT/RO/105) will be issued in due course, subject to prescriptions concerning national security, and the date shown on this Acknowledgement Receipt will establish the international filing date of the application.

# REPLACEMENT SHEET 1/10

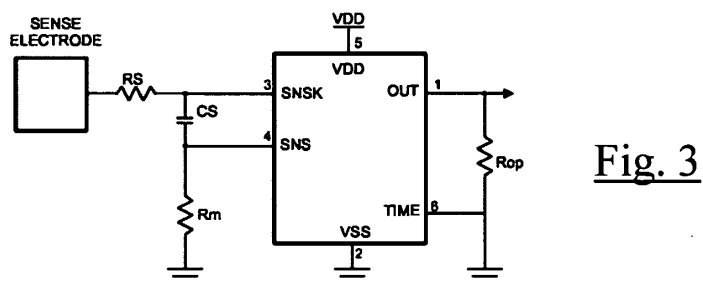
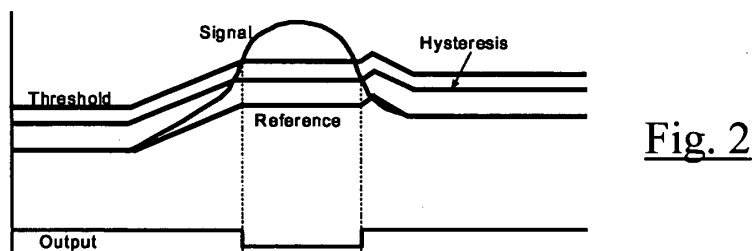
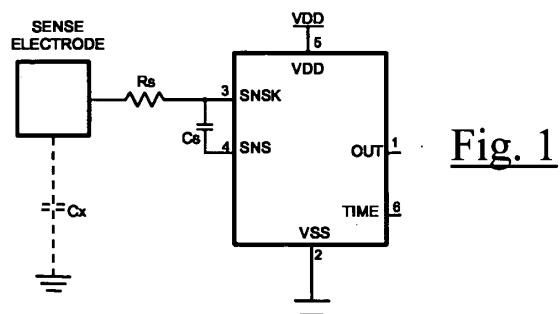

# REPLACEMENT SHEET 2/10

(Output in On condition)

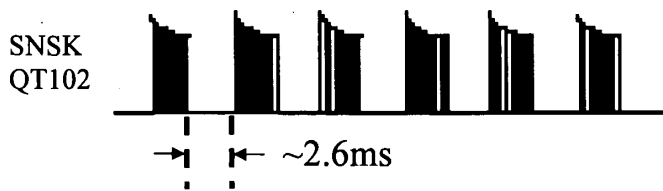

Fig. 4

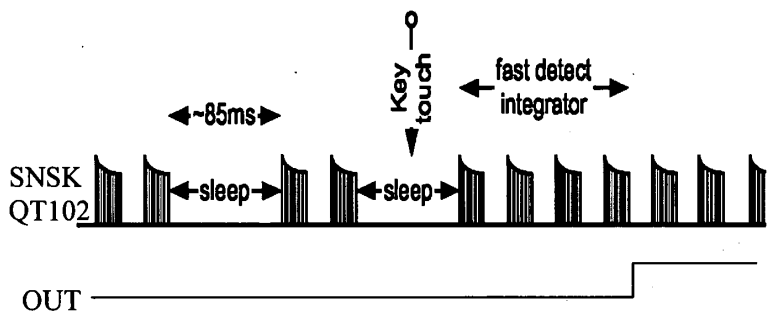

Fig. 5

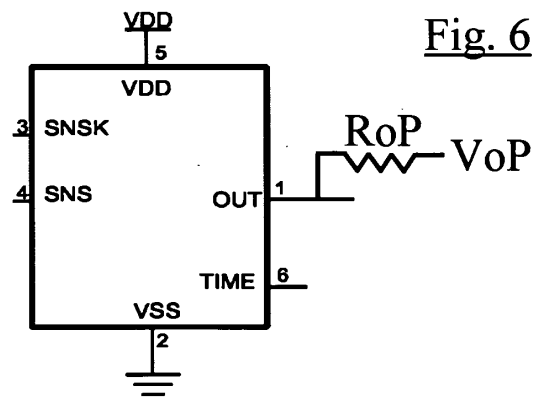
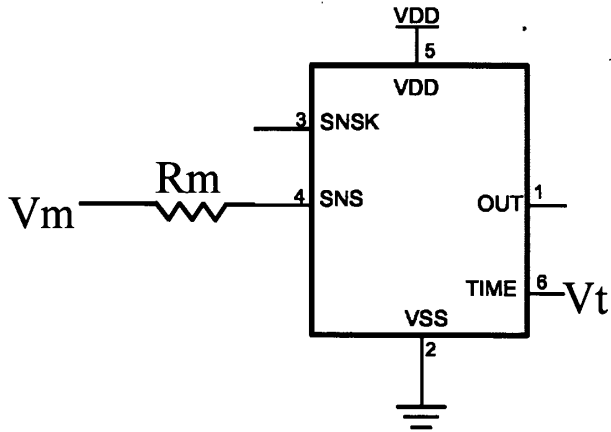
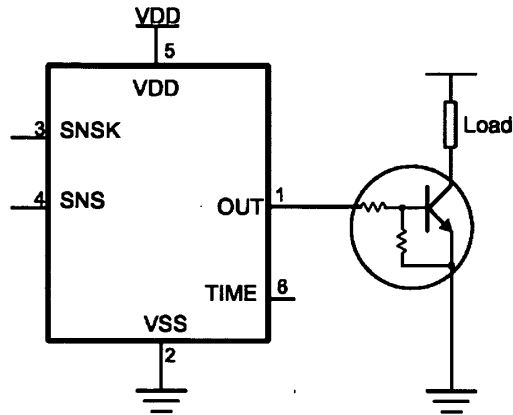

Fig. 6

REPLACEMENT SHEET 3/10





REPLACEMENT SHEET 4/10

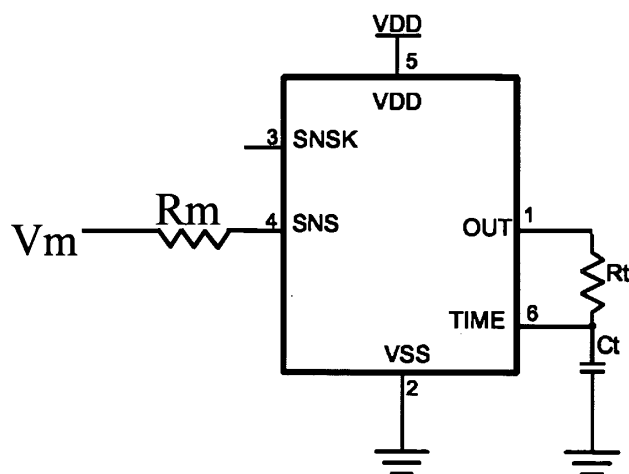

Fig. 9

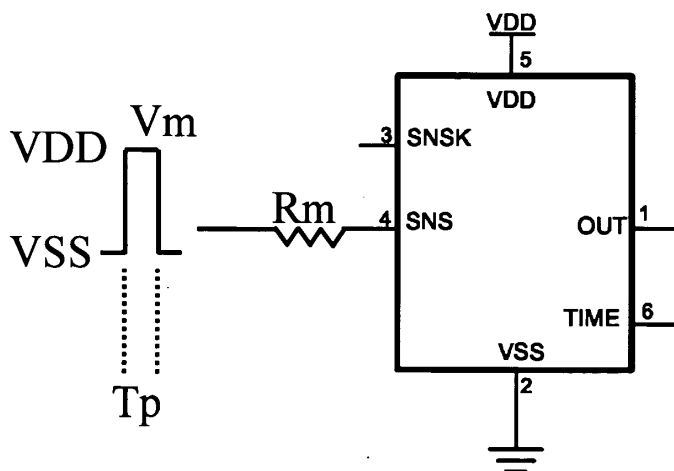
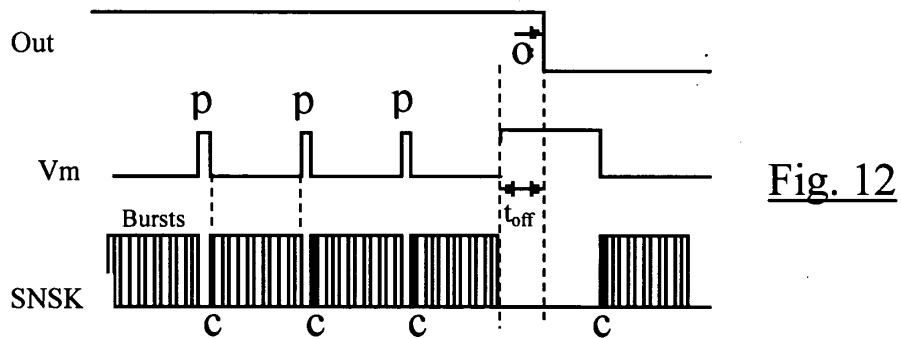
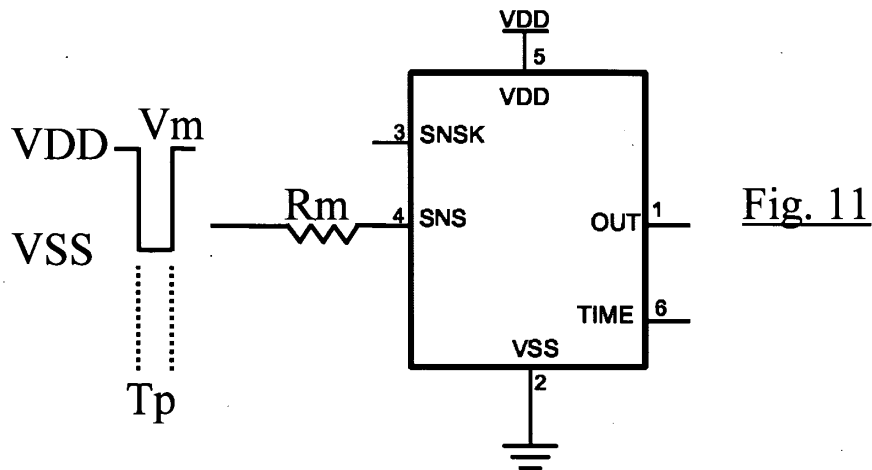

Fig. 10

# REPLACEMENT SHEET 5/10



- P - override (reload auto off delay)
- O - switch output off ( $t_{off}$  burst time + 50ms)
- C - sensor recalibration

# REPLACEMENT SHEET 6/10

## QT102 Active High Output

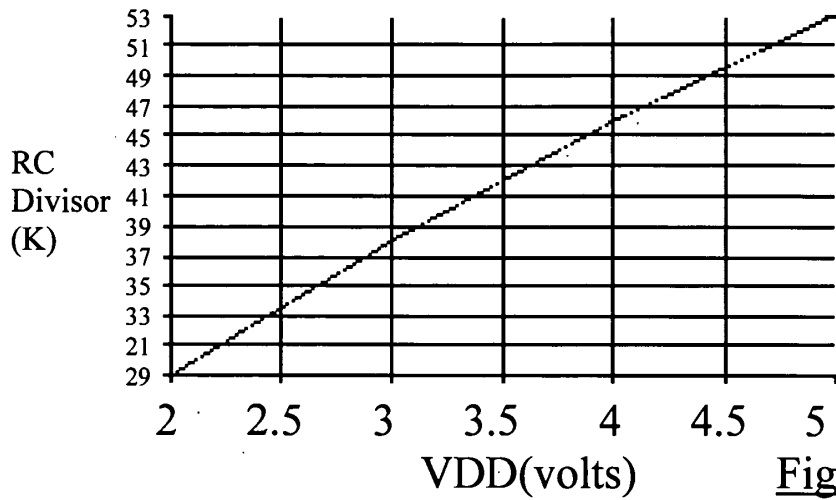

Fig. 13

## QT102 Active Low Output

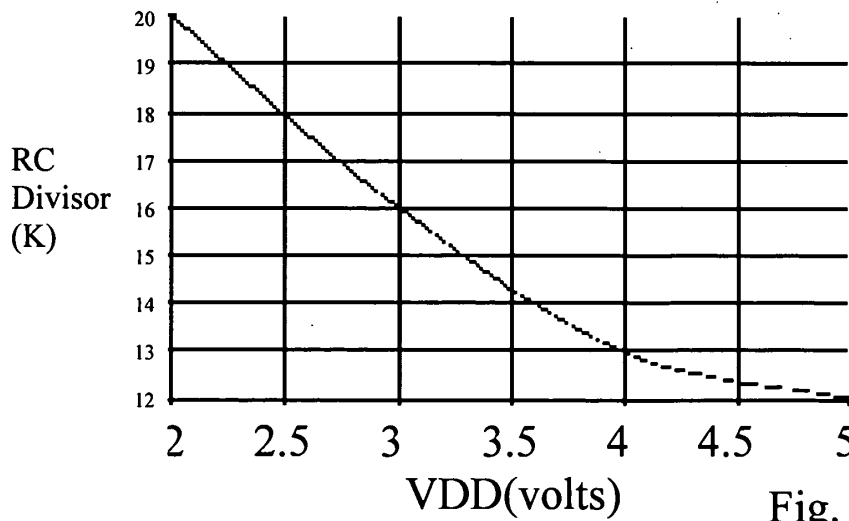

Fig. 14

# REPLACEMENT SHEET 7/10

$V_m = V_{ss}$  (delay multiplier = x1)

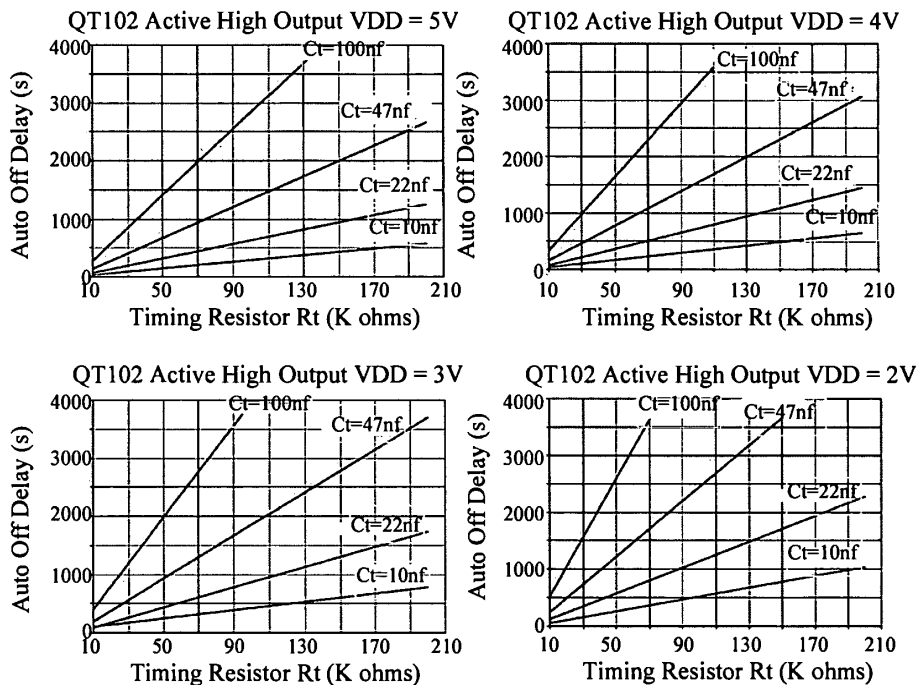

Fig. 15

# REPLACEMENT SHEET 8/10

$V_m = V_{ss}$  (delay multiplier = x1)

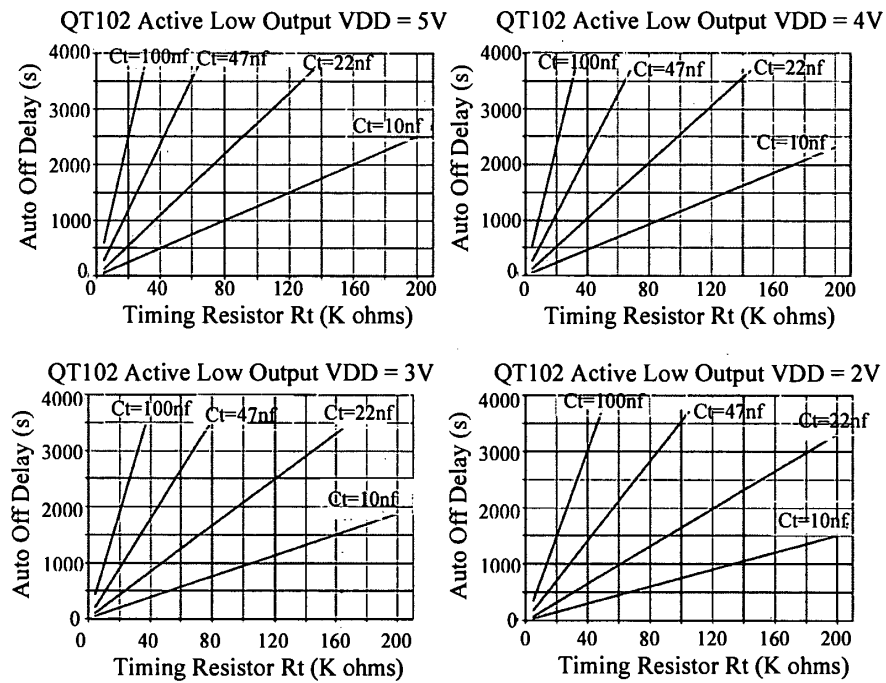

Fig. 16

# REPLACEMENT SHEET 9/10

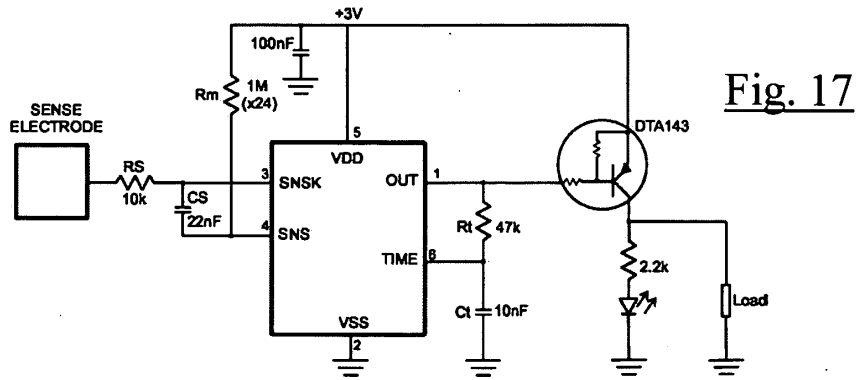

Fig. 17

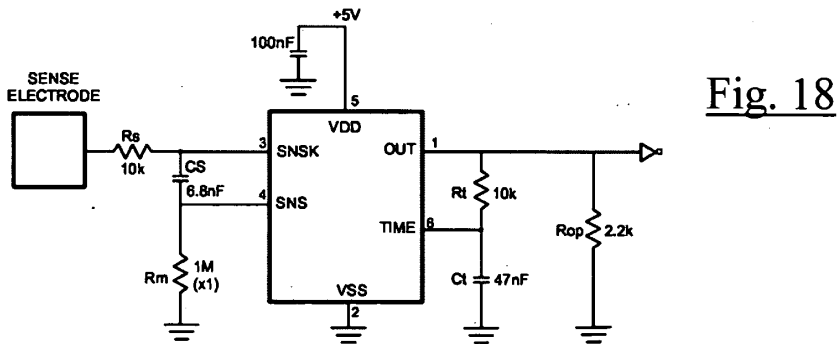
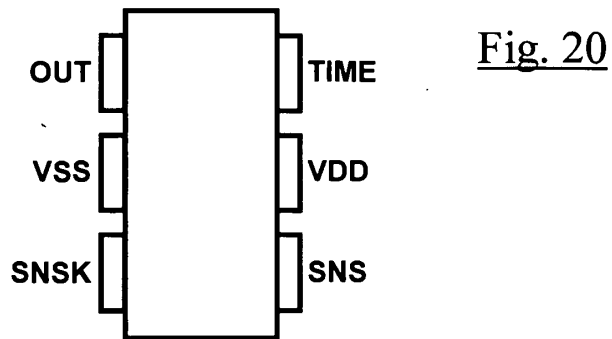
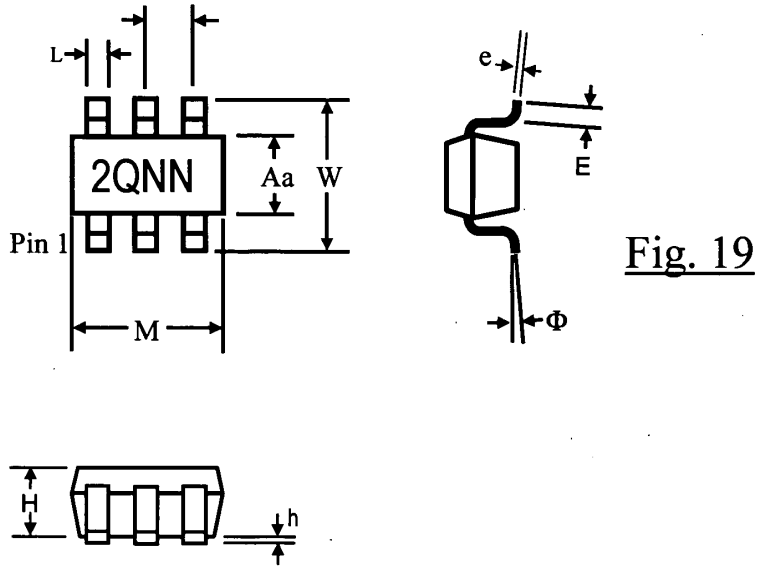

Fig. 18

REPLACEMENT SHEET 10/10





UNITED STATES PATENT AND TRADEMARK OFFICE

UNITED STATES DEPARTMENT OF COMMERCE
United States Patent and Trademark Office
Address: COMMISSIONER FOR PATENTS
P.O. Box 1450
Alexandria, Virginia 22313-1450
www.uspto.gov

Table with 4 columns: APPLICATION NUMBER (12/179,769), FILING OR 371(C) DATE (07/25/2008), FIRST NAMED APPLICANT (Harald Philipp), ATTY. DOCKET NO./TITLE (QAP)

CONFIRMATION NO. 8745

FORMALITIES LETTER

20191
DAVID KIEWIT
5901 THIRD ST SOUTH
ST PETERSBURG, FL 33705



Date Mailed: 09/10/2008

NOTICE OF INCOMPLETE REPLY (NONPROVISIONAL)

Filing Date Granted

The U.S. Patent and Trademark Office has received your reply on 08/31/2008 to the Notice to File Missing Parts (Notice) mailed 08/05/2008 and it has been entered into the nonprovisional application. The reply, however, does not include the following items required in the Notice.

The period of reply remains as set forth in the Notice. You may, however, obtain EXTENSIONS OF TIME under the provisions of 37 CFR 1.136(a) accompanied by the appropriate fee (37 CFR 1.17(a)).

A complete reply must be timely filed to prevent ABANDONMENT of the above-identified application. Replies should be mailed to: Mail Stop Missing Parts, Commissioner for Patents, P.O. Box 1450, Alexandria VA 22313-1450.

- The oath or declaration is missing.
A properly signed oath or declaration in compliance with 37 CFR 1.63, identifying the application by the above Application Number and Filing Date, is required.
Note: If a petition under 37 CFR 1.47 is being filed, an oath or declaration in compliance with 37 CFR 1.63 signed by all available joint inventors, or if no inventor is available by a party with sufficient proprietary interest, is required.



Replies should be mailed to:

Mail Stop Missing Parts  
Commissioner for Patents  
P.O. Box 1450  
Alexandria VA 22313-1450

Registered users of EFS-Web may alternatively submit their reply to this notice via EFS-Web.  
<https://sportal.uspto.gov/authenticate/AuthenticateUserLocalEPF.html>

For more information about EFS-Web please call the USPTO Electronic Business Center at **1-866-217-9197** or visit our website at <http://www.uspto.gov/ebc>.

If you are not using EFS-Web to submit your reply, you must include a copy of this notice.

/malemahu/

---

Office of Data Management, Application Assistance Unit (571) 272-4000, or (571) 272-4200, or 1-888-786-0101

**DECLARATION (37 CFR 1.63) FOR UTILITY OR DESIGN APPLICATION USING AN APPLICATION DATA SHEET (37 CFR 1.76)**

<b>Title of Invention</b>	Proximity Sensor
---------------------------	------------------

As the below named inventor(s), I/we declare that:

This declaration is directed to:

- The attached application, or  
 Application No. 12/179,769 filed on July 25, 2008  
 As amended on \_\_\_\_\_ (if applicable);

I/we believe that I/we am/are the original and first inventor(s) of the subject matter which is claimed and for which a patent is sought;

I/we have reviewed and understand the contents of the above-identified application, including the claims, as amended by any amendment specifically referred to above;

I/we acknowledge the duty to disclose to the United States Patent and Trademark Office all information known to me/us to be material to patentability as defined in 37 CFR 1.56, including for continuation-in-part applications, material information which became available between the filing date of the prior application and the national or PCT International filing date of the continuation-in-part application.

**WARNING:**

Petitioner/applicant is cautioned to avoid submitting personal information in documents filed in a patent application that may contribute to identity theft. Personal information such as social security numbers, bank account numbers, or credit card numbers (other than a check or credit card authorization form PTO-2038 submitted for payment purposes) is never required by the USPTO to support a petition or an application. If this type of personal information is included in documents submitted to the USPTO, petitioners/applicants should consider redacting such personal information from the documents before submitting them to the USPTO. Petitioner/applicant is advised that the record of a patent application is available to the public after publication of the application (unless a non-publication request in compliance with 37 CFR 1.213(a) is made in the application) or issuance of a patent. Furthermore, the record from an abandoned application may also be available to the public if the application is referenced in a published application or an issued patent (see 37 CFR 1.14). Checks and credit card authorization forms PTO-2038 submitted for payment purposes are not retained in the application file and therefore are not publicly available.

All statements made herein of my/our own knowledge are true, all statements made herein on information and belief are believed to be true, and further that these statements were made with the knowledge that willful false statements and the like are punishable by fine or imprisonment, or both, under 18 U.S.C. 1001, and may jeopardize the validity of the application or any patent issuing thereon.

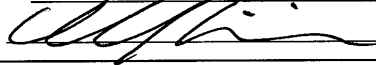
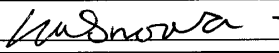
<b>FULL NAME OF INVENTOR(S)</b>	
Inventor one: <u>Harald Philipp</u>	Date: <u>17 September 2008</u>
Signature: 	Citizen of: <u>US</u>
Inventor two: <u>Kevin Snoad</u>	Date: <u>3 August 2008</u>
Signature: 	Citizen of: <u>GB</u>
<input type="checkbox"/> Additional inventors or a legal representative are being named on _____ additional form(s) attached hereto.	

This collection of information is required by 35 U.S.C. 115 and 37 CFR 1.63. The information is required to obtain or retain a benefit by the public which is to file (and by the USPTO to process) an application. Confidentiality is governed by 35 U.S.C. 122 and 37 CFR 1.11 and 1.14. This collection is estimated to take 1 minute to complete, including gathering, preparing, and submitting the completed application form to the USPTO. Time will vary depending upon the individual case. Any comments on the amount of time you require to complete this form and/or suggestions for reducing this burden, should be sent to the Chief Information Officer, U.S. Patent and Trademark Office, U.S. Department of Commerce, P.O. Box 1450, Alexandria, VA 22313-1450. DO NOT SEND FEES OR COMPLETED FORMS TO THIS ADDRESS. SEND TO: Commissioner for Patents, P.O. Box 1450, Alexandria, VA 22313-1450.  
 If you need assistance in completing the form, call 1-800-PTO-9199 and select option 2.

Electronic Patent Application Fee Transmittal				
<b>Application Number:</b>	12179769			
<b>Filing Date:</b>	25-Jul-2008			
<b>Title of Invention:</b>	Proximity Sensor			
<b>First Named Inventor/Applicant Name:</b>	Harald Philipp			
<b>Filer:</b>	David A. Kiewit			
<b>Attorney Docket Number:</b>	QAP			
Filed as Large Entity				
<b>Utility under 35 USC 111(a) Filing Fees</b>				
Description	Fee Code	Quantity	Amount	Sub-Total in USD(\$)
<b>Basic Filing:</b>				
<b>Pages:</b>				
<b>Claims:</b>				
<b>Miscellaneous-Filing:</b>				
Late filing fee for oath or declaration	1051	1	130	130
<b>Petition:</b>				
<b>Patent-Appeals-and-Interference:</b>				
<b>Post-Allowance-and-Post-Issuance:</b>				
<b>Extension-of-Time:</b>				

Description	Fee Code	Quantity	Amount	Sub-Total in USD(\$)
<b>Miscellaneous:</b>				
<b>Total in USD (\$)</b>				<b>130</b>

## Electronic Acknowledgement Receipt

<b>EFS ID:</b>	3962288
<b>Application Number:</b>	12179769
<b>International Application Number:</b>	
<b>Confirmation Number:</b>	8745
<b>Title of Invention:</b>	Proximity Sensor
<b>First Named Inventor/Applicant Name:</b>	Harald Philipp
<b>Customer Number:</b>	20191
<b>Filer:</b>	David A. Kiewit
<b>Filer Authorized By:</b>	
<b>Attorney Docket Number:</b>	QAP
<b>Receipt Date:</b>	18-SEP-2008
<b>Filing Date:</b>	25-JUL-2008
<b>Time Stamp:</b>	09:46:17
<b>Application Type:</b>	Utility under 35 USC 111(a)

### Payment information:

Submitted with Payment	yes
Payment Type	Credit Card
Payment was successfully received in RAM	\$ 130
RAM confirmation Number	7417
Deposit Account	
Authorized User	

### File Listing:

Document Number	Document Description	File Name	File Size(Bytes)/ Message Digest	Multi Part /.zip	Pages (if appl.)
-----------------	----------------------	-----------	-------------------------------------	------------------	------------------

1	Oath or Declaration filed	gapdecls.pdf	74033 ee2cf4a050ce77edf6ef1b8b8d11c492486d aa1e	no	1
<b>Warnings:</b>					
<b>Information:</b>					
2	Fee Worksheet (PTO-06)	fee-info.pdf	29794 eb485bb0d025c92af0d6eca14eeefaf79072 2c99	no	2
<b>Warnings:</b>					
<b>Information:</b>					
<b>Total Files Size (in bytes):</b>				103827	
<p>This Acknowledgement Receipt evidences receipt on the noted date by the USPTO of the indicated documents, characterized by the applicant, and including page counts, where applicable. It serves as evidence of receipt similar to a Post Card, as described in MPEP 503.</p> <p><b><u>New Applications Under 35 U.S.C. 111</u></b>  If a new application is being filed and the application includes the necessary components for a filing date (see 37 CFR 1.53(b)-(d) and MPEP 506), a Filing Receipt (37 CFR 1.54) will be issued in due course and the date shown on this Acknowledgement Receipt will establish the filing date of the application.</p> <p><b><u>National Stage of an International Application under 35 U.S.C. 371</u></b>  If a timely submission to enter the national stage of an international application is compliant with the conditions of 35 U.S.C. 371 and other applicable requirements a Form PCT/DO/EO/903 indicating acceptance of the application as a national stage submission under 35 U.S.C. 371 will be issued in addition to the Filing Receipt, in due course.</p> <p><b><u>New International Application Filed with the USPTO as a Receiving Office</u></b>  If a new international application is being filed and the international application includes the necessary components for an international filing date (see PCT Article 11 and MPEP 1810), a Notification of the International Application Number and of the International Filing Date (Form PCT/RO/105) will be issued in due course, subject to prescriptions concerning national security, and the date shown on this Acknowledgement Receipt will establish the international filing date of the application.</p>					

9-18-08

Electronic Patent Application Fee Transmittal				
<b>Application Number:</b>		12179769		
<b>Filing Date:</b>		25-Jul-2008		
Adjustment date: 09/23/2008 AGDITOM 09/18/2008 INTEFSW 00007417 12179769 01 FC:1051 -130.00 OP				
<b>Title of Invention:</b>		Proximity Sensor		
Refund Ref: 0030061478 09/23/2008				
Credit Card Refund Total: \$130.00				
VISA... : XXXXXXXXXXXXX2908 <b>First Named Inventor/Applicant Name:</b>		Harald Philipp		
<b>Filer:</b>		David A. Kiewit		
<b>Attorney Docket Number:</b>		QAP		
Filed as Large Entity				
<b>Utility under 35 USC 111(a) Filing Fees</b>				
Description	Fee Code	Quantity	Amount	Sub-Total in USD(\$)
<b>Basic Filing:</b>				
<b>Pages:</b>				
<b>Claims:</b>				
<b>Miscellaneous-Filing:</b>				
Late filing fee for oath or declaration	1051	1	130	130
<b>Petition:</b>				
<b>Patent-Appeals-and-Interference:</b>				
<b>Post-Allowance-and-Post-Issuance:</b>				
<b>Extension-of-Time:</b>				



UNITED STATES PATENT AND TRADEMARK OFFICE

UNITED STATES DEPARTMENT OF COMMERCE
United States Patent and Trademark Office
Address: COMMISSIONER FOR PATENTS
P.O. Box 1450
Alexandria, Virginia 22313-1450
www.uspto.gov

Table with 7 columns: APPLICATION NUMBER, FILING or 371(c) DATE, GRP ART UNIT, FIL FEE REC'D, ATTY.DOCKET.NO, TOT CLAIMS, IND CLAIMS. Row 1: 12/179,769, 07/25/2008, 2878, 1310, QAP, 23, 2

CONFIRMATION NO. 8745

UPDATED FILING RECEIPT

20191
DAVID KIEWIT
5901 THIRD ST SOUTH
ST PETERSBURG, FL 33705



Date Mailed: 09/26/2008

Receipt is acknowledged of this non-provisional patent application. The application will be taken up for examination in due course. Applicant will be notified as to the results of the examination. Any correspondence concerning the application must include the following identification information: the U.S. APPLICATION NUMBER, FILING DATE, NAME OF APPLICANT, and TITLE OF INVENTION. Fees transmitted by check or draft are subject to collection. Please verify the accuracy of the data presented on this receipt. If an error is noted on this Filing Receipt, please submit a written request for a Filing Receipt Correction. Please provide a copy of this Filing Receipt with the changes noted thereon. If you received a "Notice to File Missing Parts" for this application, please submit any corrections to this Filing Receipt with your reply to the Notice. When the USPTO processes the reply to the Notice, the USPTO will generate another Filing Receipt incorporating the requested corrections

Applicant(s)

Harald Philipp, Southampton, UNITED KINGDOM;
Kevin Snoad, Chicester, UNITED KINGDOM;

Assignment For Published Patent Application

QRG LIMITED, Eastleigh, UNITED KINGDOM

Power of Attorney: None

Domestic Priority data as claimed by applicant

This appln claims benefit of 60/952,053 07/26/2007

Foreign Applications

If Required, Foreign Filing License Granted: 08/01/2008

The country code and number of your priority application, to be used for filing abroad under the Paris Convention, is US 12/179,769

Projected Publication Date: 01/29/2009

Non-Publication Request: No

Early Publication Request: No



**Title**

Proximity Sensor

**Preliminary Class**

250

**PROTECTING YOUR INVENTION OUTSIDE THE UNITED STATES**

Since the rights granted by a U.S. patent extend only throughout the territory of the United States and have no effect in a foreign country, an inventor who wishes patent protection in another country must apply for a patent in a specific country or in regional patent offices. Applicants may wish to consider the filing of an international application under the Patent Cooperation Treaty (PCT). An international (PCT) application generally has the same effect as a regular national patent application in each PCT-member country. The PCT process **simplifies** the filing of patent applications on the same invention in member countries, but **does not result** in a grant of "an international patent" and does not eliminate the need of applicants to file additional documents and fees in countries where patent protection is desired.

Almost every country has its own patent law, and a person desiring a patent in a particular country must make an application for patent in that country in accordance with its particular laws. Since the laws of many countries differ in various respects from the patent law of the United States, applicants are advised to seek guidance from specific foreign countries to ensure that patent rights are not lost prematurely.

Applicants also are advised that in the case of inventions made in the United States, the Director of the USPTO must issue a license before applicants can apply for a patent in a foreign country. The filing of a U.S. patent application serves as a request for a foreign filing license. The application's filing receipt contains further information and guidance as to the status of applicant's license for foreign filing.

Applicants may wish to consult the USPTO booklet, "General Information Concerning Patents" (specifically, the section entitled "Treaties and Foreign Patents") for more information on timeframes and deadlines for filing foreign patent applications. The guide is available either by contacting the USPTO Contact Center at 800-786-9199, or it can be viewed on the USPTO website at <http://www.uspto.gov/web/offices/pac/doc/general/index.html>.

For information on preventing theft of your intellectual property (patents, trademarks and copyrights), you may wish to consult the U.S. Government website, <http://www.stopfakes.gov>. Part of a Department of Commerce initiative, this website includes self-help "toolkits" giving innovators guidance on how to protect intellectual property in specific countries such as China, Korea and Mexico. For questions regarding patent enforcement issues, applicants may call the U.S. Government hotline at 1-866-999-HALT (1-866-999-4158).

**LICENSE FOR FOREIGN FILING UNDER****Title 35, United States Code, Section 184****Title 37, Code of Federal Regulations, 5.11 & 5.15****GRANTED**

The applicant has been granted a license under 35 U.S.C. 184, if the phrase "IF REQUIRED, FOREIGN FILING LICENSE GRANTED" followed by a date appears on this form. Such licenses are issued in all applications where the conditions for issuance of a license have been met, regardless of whether or not a license may be required as

page 2 of 3

set forth in 37 CFR 5.15. The scope and limitations of this license are set forth in 37 CFR 5.15(a) unless an earlier license has been issued under 37 CFR 5.15(b). The license is subject to revocation upon written notification. The date indicated is the effective date of the license, unless an earlier license of similar scope has been granted under 37 CFR 5.13 or 5.14.

This license is to be retained by the licensee and may be used at any time on or after the effective date thereof unless it is revoked. This license is automatically transferred to any related applications(s) filed under 37 CFR 1.53(d). This license is not retroactive.

The grant of a license does not in any way lessen the responsibility of a licensee for the security of the subject matter as imposed by any Government contract or the provisions of existing laws relating to espionage and the national security or the export of technical data. Licensees should apprise themselves of current regulations especially with respect to certain countries, of other agencies, particularly the Office of Defense Trade Controls, Department of State (with respect to Arms, Munitions and Implements of War (22 CFR 121-128)); the Bureau of Industry and Security, Department of Commerce (15 CFR parts 730-774); the Office of Foreign AssetsControl, Department of Treasury (31 CFR Parts 500+) and the Department of Energy.

**NOT GRANTED**

No license under 35 U.S.C. 184 has been granted at this time, if the phrase "IF REQUIRED, FOREIGN FILING LICENSE GRANTED" DOES NOT appear on this form. Applicant may still petition for a license under 37 CFR 5.12, if a license is desired before the expiration of 6 months from the filing date of the application. If 6 months has lapsed from the filing date of this application and the licensee has not received any indication of a secrecy order under 35 U.S.C. 181, the licensee may foreign file the application pursuant to 37 CFR 5.15(b).





(21) Application No: 0618960.9  
 (22) Date of Filing: 26.09.2006  
 (30) Priority Data:  
 (31) 60722476 (32) 30.09.2005 (33) US  
 (31) 11333489 (32) 17.01.2006

(51) INT CL:  
 H03K 17/955 (2006.01) H04M 1/73 (2006.01)  
 H04R 1/10 (2006.01) H04R 5/033 (2006.01)

(52) UK CL (Edition X):  
 G1N NDPX N19B2B

(56) Documents Cited:  
 GB 2357400 A EP 1260082 A1  
 EP 0564164 A1 WO 2005/099105 A1  
 WO 2003/103175 A1 US 6466036 B1  
 US 20020068537 A1

(71) Applicant(s):  
 Harald Philipp  
 7 Cirrus Gardens, Hamble,  
 SOUTHAMPTON, Hampshire, SO31 4RH,  
 United Kingdom

(72) Inventor(s):  
 Harald Philipp

(74) Agent and/or Address for Service:  
 D Young & Co  
 120 Holborn, LONDON, EC1N 2DY,  
 United Kingdom

(58) Field of Search:  
 UK CL (Edition X) G1N  
 INT CL H03K, H04R  
 Other:

(54) Abstract Title: **Headset and headset power management**

(57) A headset (100) includes a capacitive sensor (160) to detect the presence of a user. Capacitive sensing is advantageous since it provides a reliable sensor that can accurately detect the presence or absence of a user either by detecting user proximity or user contact. The sensitivity of a capacitive sensor may be adjusted to account for user movement or changes in environmental conditions such as the presence of water or sweat on the headset to further improve sensing reliability. A control circuit is operable to control a function of the headset depending on whether a user wears the headset or not. Such a circuit may be a power management circuit to reduce power to the headset when a user is not sensed. User presence signals based on capacitive sensing in a headset could also control other functions of the headset or control external devices, such as a phone, to which the headset is connected, either wirelessly or by wires.

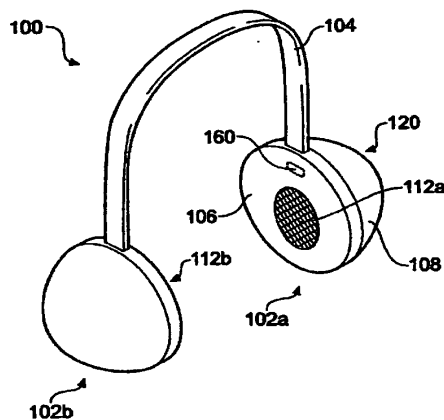

Fig. 1

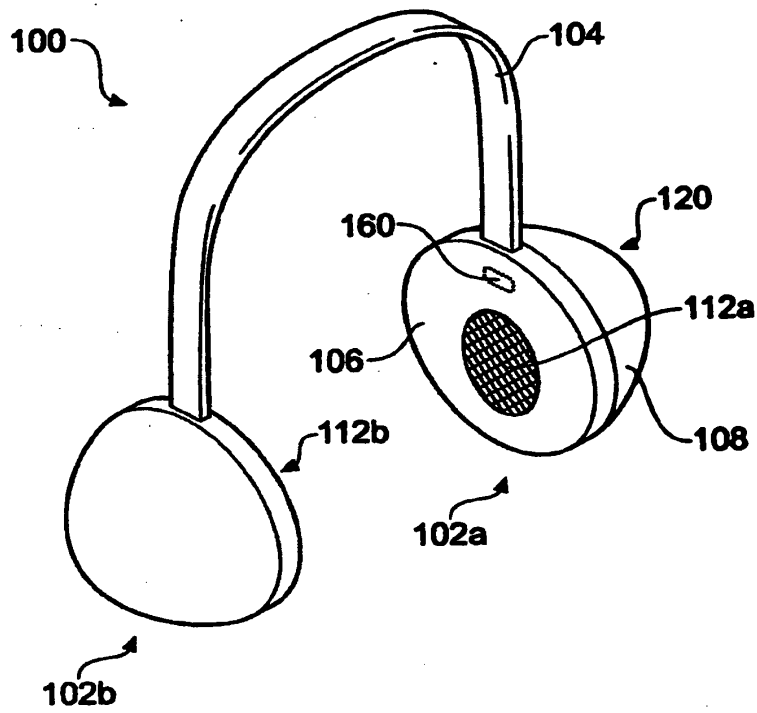

Fig. 1

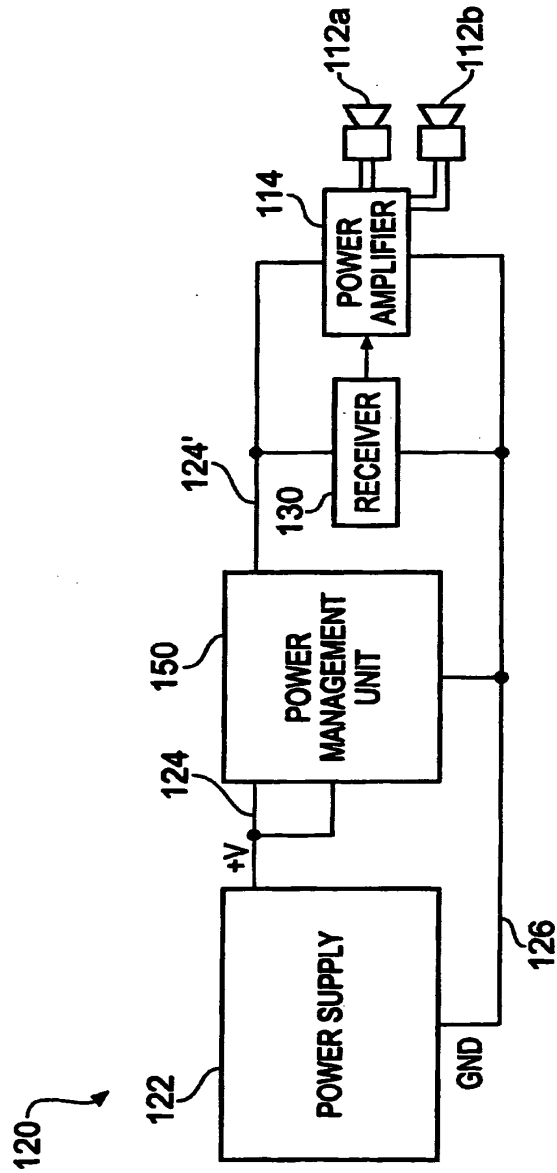

Fig. 2

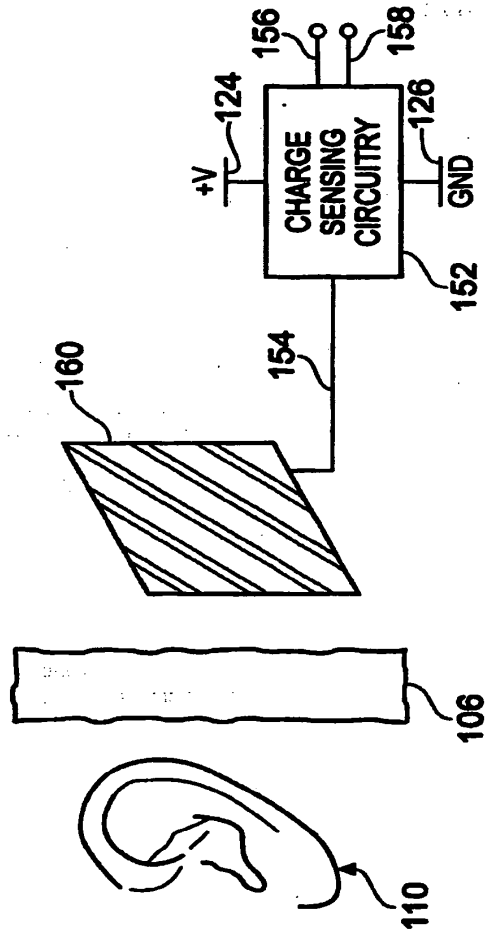

Fig. 3



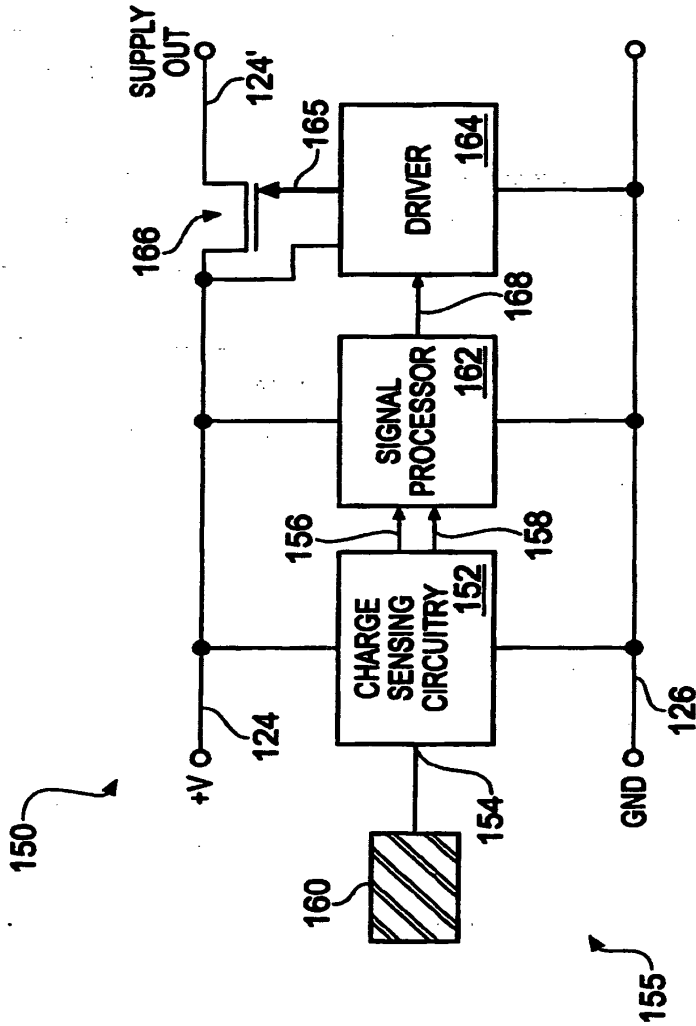

Fig. 4

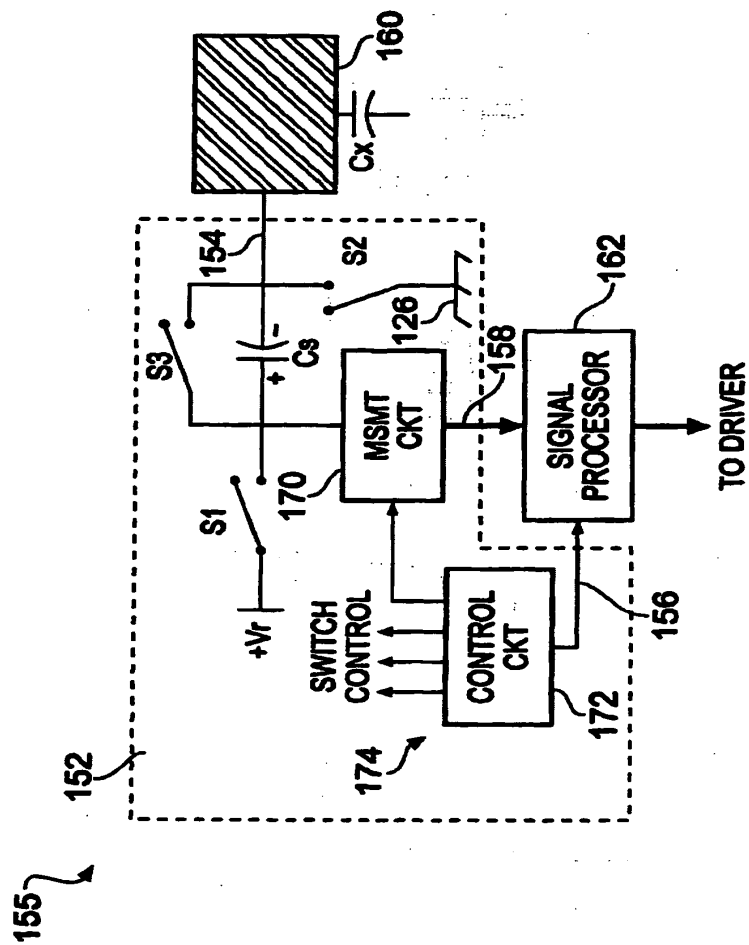

Fig. 5

STEP	S1	S2	S3	FUNCTION
A	-	X	X	RESET ALL
B	-	-	-	DEADTIME
C	X	-	-	CHARGE-TRANSFER
D	-	-	-	DEADTIME
E	-	X	-	HOLD
F	-	X	-	MEASURE

LOOP

Fig. 6

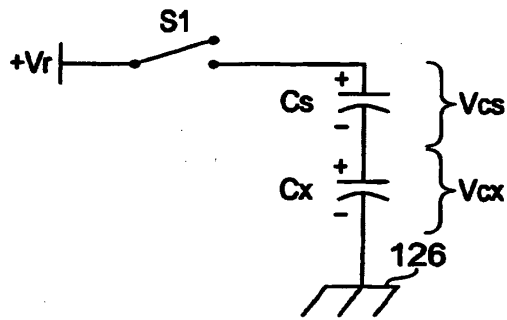

Fig. 7

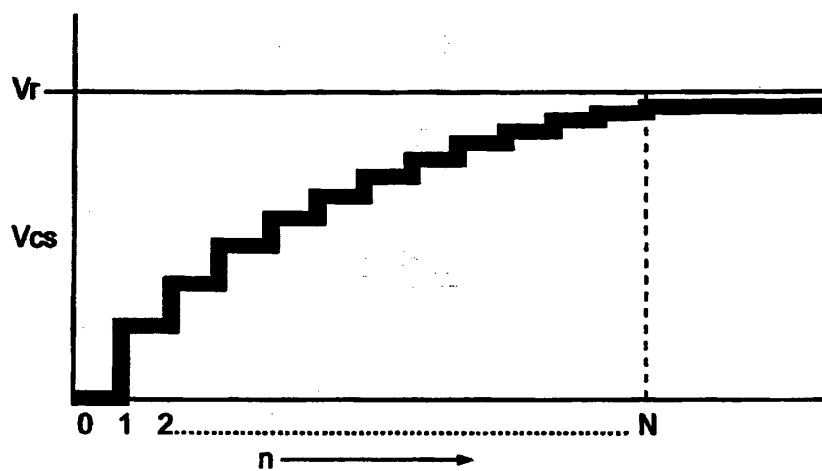
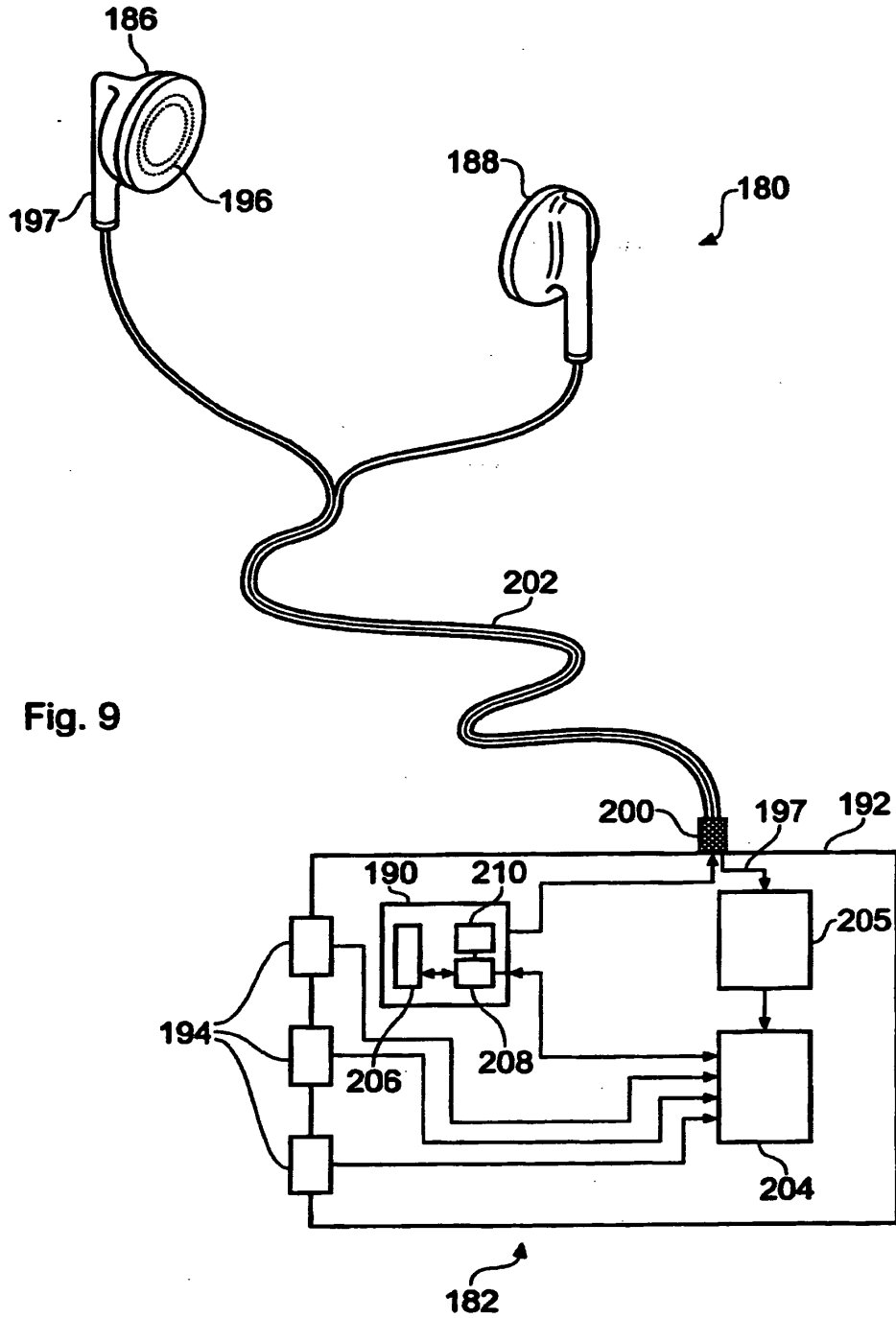

Fig. 8

8/9



9/9

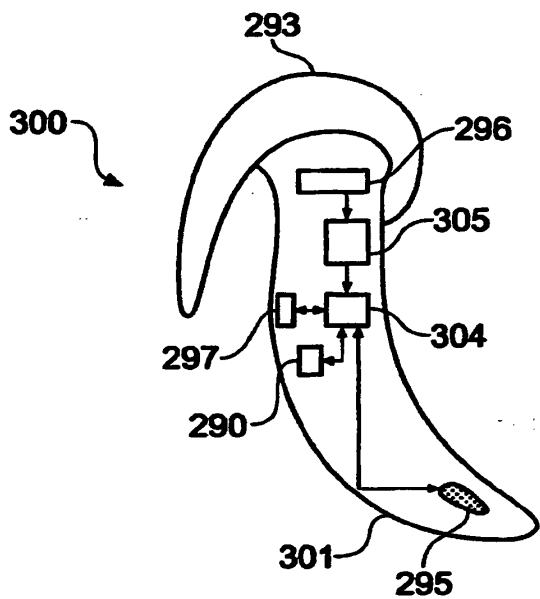

Fig. 10A

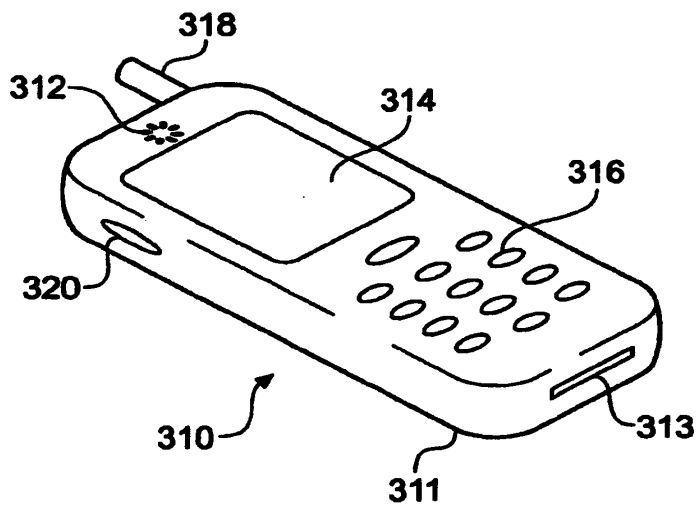

Fig. 10B

**Headsets and headset power management****Field**

5 The invention relates to apparatus comprising headsets and more especially but not exclusively to power management and/or function control of such apparatus. In particular, the invention relates to power management in a headset that comprises one or more circuit elements that consume electrical power such as, for example, a Bluetooth™ or other wireless receiver.

**Background**

10 Many different types of headset have been designed by numerous manufacturers with various types of end user application in mind. For example, stereo headphones for listening to music have been around for many years, as have ear pieces for use with hearing aids, portable radios and the like [1-3].

15 Recently, many new types of headset that can be worn by a user have been developed with a view to using them with mobile cellular telephones or other portable electronic devices. Numerous headset designs have been created to enable a user to use such a portable electronic device without the need to hold the electronic device: the so-called "hands-free" mode of operation.

20 Many of the recently developed headsets are cordless devices that incorporate a Bluetooth™ receiver or a Bluetooth™ receiver/transmitter. Bluetooth™ is a radio-frequency communications standard developed by a group of electronics manufacturers that allows various types of electronic equipment to interconnect, without the need for wires, cables or detailed user intervention. The Bluetooth™ standard enables various electronic devices to inter-operate, since all electronic  
25 products that use Bluetooth™ have to use an agreed standard that dictates when data bits are sent, how many data bits are sent at any one time, how data transmission errors are handled, etc.

Whilst improved design has lead to improvements in the size and weight of headsets, the functionality of headsets has increased dramatically. This has increased pressure on engineers to consider how most efficiently to use the electrical power available, particularly for cordless battery-operated headsets where battery life and available power are limited.

With a view to improving power usage, various manufacturers have developed headsets that incorporate power management features.

One prior art design is that of the Sony™ MDR-DS8000 headset available from Sony™ Corporation. In this headset, an electromechanical switch is provided that changes state when the ear pieces are pulled apart when the headset is being put on by a user. This is done by the headband expanding and pulling on a switch mechanism.

In another prior art design [4], an inductive noise signal is provided by a metallic ring built into an ear piece when the ear piece contacts a user. This signal is used to detect the presence or absence of a user to determine whether or not to power-down a signal amplifier.

While these known power-saving headsets fulfil the desired function, they are not without various drawbacks. For example, mechanical switches are relatively bulky and expensive, and they can also suffer from long-term reliability problems. Moreover, the mechanical headband switch approach is not transferable to non-headband based headsets such as single-ear devices, for example ones that operate wirelessly by Bluetooth™ or otherwise. Sensing user presence based upon detecting inductive noise is also less than ideal, particularly given the random nature of such noise and its amplitude variability according to differing physical conditions, such as the degree of electrode contact with the user (e.g. if a user is jogging), prevailing environmental conditions (e.g. if a user is sweating or is exposed to rain), etc.



**Summary of the invention**

According to a first aspect of the invention, there is provided an apparatus comprising:  
a headset including a sensing element; a capacitance measurement circuit operable to  
measure the capacitance of the sensing element; and a control circuit operable to  
5 determine whether a user is wearing the headset based on a measurement of the  
capacitance of the sensing element, and to control a function of the apparatus  
according to whether the headset is being worn.

Thus a simple and reliable way of controlling functions of an apparatus in dependence  
on whether or not a headset is being worn is provided. Various functions can be  
10 controlled. For example, the controlled function may be a power saving function.  
Alternatively, the function may relate to activation of an audio amplifier, activation of  
a wireless communications transceiver, outputting of an audio signal by an audio  
generator, and/or the inhibition of user input signals, for example.

Any form of capacitance measurement circuitry may be employed, for example  
15 circuitry based on RC circuits, relaxation oscillators, phase shift measurements, phase  
locked loop circuitry, capacitive divider circuitry may be used. Capacitance  
measurement based on charge transfer techniques in particular are well suited to this  
application. Thus the capacitance measurement circuit may include a sample capacitor  
and be operable to transfer charge from the sensing element to the sample capacitor to  
20 generate an electric potential at the sample capacitor for measuring. Furthermore, the  
capacitance measurement circuit may comprise a switch operable to transfer a burst of  
charge packets sequentially from the sensing element to the sample capacitor prior to a  
measurement of the electric potential being made.

The control circuit may be operable to determine whether a user is wearing the headset  
25 by comparing a measured capacitance of the sensing element to one or more  
predetermined threshold values. The measured capacitance may be an absolute value  
of capacitance or a differential measurement of capacitance, e.g. a difference from an  
earlier measured value.

The capacitance measurement circuit may be external to the headset, e.g. in a base unit, or may be internal to the headset. Furthermore, the control circuit and/or a circuit element providing the function to be controlled may be external to the headset, e.g. in a base unit, or may be internal to the headset.

- 5 According to a second aspect of the invention, there is provided a method of operating an apparatus comprising a headset, the method comprising: measuring the capacitance of a sensing element in the headset; determining from the measured capacitance whether a user is wearing the headset; and controlling a function of the apparatus in response to determining whether the headset is being worn.
- 10 The measuring the capacitance of the sensing element may include: transferring charge from the sensing element to a sample capacitor; measuring the electric potential at the sample capacitor; and determining the capacitance of the sensing element from the measured electric potential of the sample capacitor. Furthermore, the transferring charge from the sensing element to a sample capacitor may comprise transferring a
- 15 burst of charge packets in sequence from the sensing element to a sample capacitor.

The determining whether a user is wearing the headset or not may comprise comparing the measured capacitance of the sensing element to one or more predetermined threshold values in order to determine whether the capacitance of the sensing element has been changed due to the proximity of a user. Furthermore, the method may include

20 adjusting one or more of the threshold values in response to changes in operating conditions.

According to a third aspect of the invention, there is provided an energy saving headset comprising a power management unit operable to reduce the power consumption of the headset when it is not being worn by a user. The power management unit includes

25 a sensing circuit coupled to a capacitive sensor. The sensing circuit is operable to measure the capacitance of the capacitive sensor and to generate a user presence signal in dependence upon the measured capacitance. The user presence signal is indicative of whether a user is present or not. The power management unit is operable in

accordance with the user presence signal to control one or more circuit elements that are provided in the headset, typically a power control.

Power control will normally be by switching the circuit element on or off. However, the power control need not be a simple binary function, but may include reducing the power to a stand by level for example, or reducing the power supplied to a power amplifier so that it is still operable but at reduced gain, e.g. to suppress feedback that may otherwise occur. However, it will be understood that the user presence signal can be used, by the power management unit or otherwise, to control other functions not directly related to power. For example, the user presence signal can be used to control other functions of the headset, or to output an external output signal that can be received by other devices to which the headset is connected, either wirelessly or wired. For example, removal of the headset may be used to pause playing activity of a sound or video track, whereafter putting the headset back on will cause resumption of playing responsive once more to the user presence signal. Another example would be when placing the headset on by the user causes playback to be switched from an external loudspeaker to the headset speaker. Headsets with ambient noise canceling are also well known. For example, such headsets are successful in reducing flight noise and for increasing the fidelity of classical music playback. It is also well known that the noise canceling circuitry consumes significant power, so selective activation and deactivation of the noise canceling circuitry is one useful application of the invention.

Accordingly the invention further relates to a headset with reduced power consumption, comprising: at least one circuit element requiring power; a capacitive sensor operable to provide a capacitance measurement signal; and a power management unit including a sensing circuit operable to generate a user presence signal responsive to the capacitance measurement signal indicating whether the headset is being worn and operable to control the at least one circuit element dependent on said user presence signal, or to output an external output signal that is dependent on said user presence signal for receipt by another device to which the headset is connected. The at least one circuit element may control a function of the headset, such as its power delivery. Alternatively, the at least one circuit element may

be used indirectly to control the function of an external device by transmitting the user presence signal externally.

5 According to a fourth aspect of the invention, there is provided a method of operating a headset in order to reduce power consumption. The method comprises measuring the capacitance of a capacitive sensor, determining from the measured capacitance whether a user is present or not, and powering-down one or more circuit elements in the headset in response to determining that no user is present in order to reduce the power consumption of the headset.

10 As mentioned above, the user preference detection may be used to control functions other than power consumption. Consequently, the invention also relates to a method of operating a headset, the method comprising: measuring the capacitance of a capacitive sensor; determining from the measured capacitance whether a user is present or not; and controlling a function of the headset, or outputting an external output signal that  
15 can be received by another device to which the headset is connected, in response to determining whether the user is present or not. The external device to which the headset is connected may be connected wirelessly or by wires.

The claimed capacitive sensing solution provides a simple, inexpensive and reliable sensor which is superior to the prior art mechanical solution described above.

20 The capacitive sensor can operate either on proximity or direct contact depending on how its sensitivity is calibrated. The sensitivity of the capacitive sensor may also be dynamically adjusted to account for changes in environmental conditions, such as, for example, humidity.

25 According to a further aspect of the invention there is provided a headset with reduced power consumption, comprising: at least one circuit element requiring power; a capacitive sensor operable to provide a capacitance measurement signal; and a power management unit including a sensing circuit operable to generate a user presence signal responsive to the capacitance measurement signal indicating whether the

headset is being worn and operable to control the at least one circuit element dependent on said user presence signal.

5 The sensing circuit may include a sample capacitor and be further operable to transfer charge from the capacitive sensor to the sample capacitor to generate an electric potential at the sample capacitor for measuring.

The headset may further comprise at least one switch operable to transfer a burst of charge packets sequentially from the capacitive sensor to the sample capacitor prior to any measurement of the electric potential being made.

10

The sensing circuit may comprise a consensus filter for generating the user presence signal.

15 The sensing circuit may further be operable automatically to perform a self-calibration operation.

The capacitive sensor may comprise an electrode that is electrically isolated from the user when the headset is being worn.

20 For example, the sense electrode of the capacitive sensor may be located under the casing of a traditional hi-fi format twin ear headset or within the housing of an ear-piece that forms part of a single ear or twin ear modern-style ear-piece headset of a portable music player, Bluetooth™ accessory headset, hearing aid, etc. The sense electrode of the capacitive sensor could alternatively be provided on the headband of a  
25 traditional hi-fi format twin ear headset. It could also be provided in the form of a conductive strip within the speaker area of a headset. In general it is desirable that the sense electrode of the capacitive sensor is provided relatively near to the user's skin, since signal strength correlates with proximity.

30 At least one of the circuit elements may comprise a Bluetooth™ receiver.

According to a still further aspect of the invention there is provided a method of operating a headset in order to reduce power consumption, the method comprising: measuring the capacitance of a capacitive sensor; determining from the measured capacitance whether a user is present or not; and powering down one or more circuit  
5 elements in the headset in response to determining that no user is present in order to reduce the power consumption of the headset.

The measuring the capacitance of the capacitive sensor may include: transferring charge from the capacitive sensor to a sample capacitor; measuring the electric  
10 potential at the sample capacitor; and determining the capacitance of the capacitive sensor from the measured electric potential of the sample capacitor.

The transferring charge from the capacitive sensor to a sample capacitor may comprise transferring a burst of charge packets in sequence from the capacitive sensor to a  
15 sample capacitor.

The determining whether a user is present or not may comprise comparing the measured capacitance of the capacitive sensor to one or more predetermined threshold values in order to determine whether the capacitance of the capacitive sensor has been  
20 changed by the proximity of the user.

The method may comprise adjusting one or more of the threshold values in response to changes in operating conditions.

**Brief description of the drawings**

For a better understanding of the invention and to show how the same may be carried into effect, reference is now made to the accompanying drawings in which:

5 Figure 1 shows a schematic diagram of an energy saving headset according to an embodiment of the present invention;

Figure 2 shows a schematic diagram of headset electronics for use in various headsets made in accordance with the present invention;

Figure 3 shows a schematic diagram illustrating the physical configuration of various components for use in various headsets made in accordance with the present invention;

10 Figure 4 shows a power management unit for use in various embodiments of the present invention;

Figure 5 shows a charge transfer capacitance measurement circuit for use in various embodiments of the present invention;

15 Figure 6 shows a switching table indicating the switching sequence of the switches used in the charge transfer capacitance measurement circuit of Figure 5;

Figure 7 shows a schematic circuit diagram depicting an electrically equivalent rearrangement of a part of the charge transfer capacitance measurement circuit of Figure 5;

20 Figure 8 shows a plot of voltage across capacitor  $C_s$  of the charge transfer capacitance measurement circuit of Figure 5 as a function of cycle number during a burst-mode operation;

Figure 9 shows a schematic diagram of an apparatus according to another embodiment of the invention; and

25 Figures 10A and 10B show schematic diagrams of an apparatus according to a further embodiment of the invention.

**Detailed description**

Figure 1 shows a schematic diagram of an energy saving headset 100. The headset 100 comprises first and second casings 102a and 102b housing respective loudspeakers 112a and 112b for reproducing stereo sound. The casings 102a and 102b are physically  
5 connected together by a headband 104 that comprises a recess for housing electrical cabling (not shown) which connects the loudspeaker 112b in the second casing 102b to headset electronics 120 housed in the first casing 102a.

The casings 102a and 102b are formed of an outer casing cover 108 and an inner cover 106 that contacts a user's ear when the headset 100 is being worn. The casing cover  
10 108 may be used to mount various user operable controls (not shown), such as, for example, volume controls, channel controls etc. The cover 106 can be provided over padding for user comfort and be made from various materials, including, for example, a flexible water-resistant polymeric sheet material. An opening in the cover 106 exposes the loudspeaker 112 to the user's respective ear when the headset 100 is being  
15 worn.

The headset electronics 120 provides a power management function in order to lessen power consumption when no user is wearing the headset 100. The headset electronics 120 uses capacitive sensing in order to detect whether or not a user is wearing the headset 100. In addition to power management, the headset electronics 120 may also  
20 provide various other functions, such as those described below.

Capacitive sensing is achieved by the headset electronics 120 measuring the capacitance of a sense plate 160, for example, by using a charge transfer technique such as that described in more detail below. The sense plate 160 is provided in the headset 100 underneath the cover 106. Hence, in this embodiment, the sense plate 160  
25 does not contact the user when the headset is being worn, and is used to detect user presence by sensing proximity of the user rather than any physical contact of the user with the sense plate 160. This makes the headset 100 as comfortable as a conventional headset that does not incorporate a power management function, and also enables a



conventional headset design to be used since the cover 106 does not need to be cut or otherwise further modified to accommodate a touch sensor.

Figure 2 shows a schematic diagram of headset electronics 120 for use in various embodiments of headsets made in accordance with the present invention. The headset electronics 120 includes a power supply 122 for powering a radio frequency (RF) receiver 130 that receives and decodes signals that are transmitted to the headset 100. The headset electronics 120 also includes a power amplifier 114 which amplifies audio signals that are decoded by the receiver 130 and feeds the amplified audio signals to respective loudspeakers 112a and 112b for stereo sound reproduction. The receiver 130 may be a conventional Bluetooth™ receiver, or other wireless receiver such as Zigbee™. Reference to wireless includes the possible use of an infrared link or radio link.

The power supply 122 can include a rechargeable battery plus associated charging and a power conditioning circuit. In alternative embodiments, the headset 100 can be powered by conventional batteries or from an external power source. However, in the embodiment of Figure 2, use of a rechargeable battery conveniently allows for cordless operation of the headset 100.

A positive output of the power supply 122 is electrically coupled to a positive supply rail 124. The negative or ground output of the power supply 122 is electrically coupled to a negative supply rail 126. The electronic components that form the headset electronics 120 are electrically coupled to the negative supply rail 126. In addition, a power management unit 150 is provided that is operable to electrically connect the positive supply rail 124 to a disconnectable portion of the positive supply rail 124'. Operation of the power management unit 150 to disconnect the portion of the positive supply rail 124' from the positive supply rail 124 cuts off the power supply to any electronic components that are powered from the portion of the positive supply rail 124', thereby reducing the total power that is consumed by the headset electronics 120 when the power management unit 150 is in a disconnect state.

When the power management unit 150 is in the disconnect state, only the power management unit 150 itself need draw any power from the power supply 122. In variants of this embodiment, any electronic components that need to be permanently in an active state are electrically connected between the positive supply rail 124 and the negative supply rail 126, while any electronic components that can be switched off when the headset 100 is not being worn are electrically connected between the portion of the positive supply rail 124' and the negative supply rail 126.

Figure 3 shows a schematic diagram illustrating the physical configuration of various components that form part of the headset 100 shown in Figure 1.

10 A portion of the cover 106 is shown in proximity to the ear of a user 110. The cover 106 separates the user 110 from the sense plate 160 that is provided in the headset 100.

Also shown, electrically coupled to the sense plate 160 by sense plate connector 154, is a charge sensing circuit 152 that forms a part of the power management unit 150. The charge sensing circuit 152 is electrically connected between the positive supply rail 124 and the negative supply rail 126 in order to draw power from the power supply 122. Two outputs, a control output 156 and a measurement output 158, are provided by the charge sensing circuit 152, these are further described below in connection with various components of the power management unit 150.

20 Figure 4 schematically shows a power management unit 150 for use in various embodiments of the present invention. The power management unit 150 comprises a charge sensing circuit 152 that is electrically coupled to a sense plate 160 by way of a sense plate connector 154.

The charge sensing circuit 152 is electrically connected between the positive supply rail 124 and the negative supply rail 126, and is operable to measure the capacitance of the sense plate 160. The charge sensing circuit 152 has two outputs 156 and 158. One of these outputs is a measurement output 158, the voltage level of which indicates the measured capacitance of the sense plate 160. The other output is a control output 156 that is used to indicate to a signal processor 162 when the voltage level of the measurement output 158 is available to be read.

The signal processor 162 is electrically connected between the positive supply rail 124 and the negative supply rail 126. It is operable to process measured capacitance values and to determine whether those measured capacitance values for the sense plate 160 indicate the presence of the user 110, a process that is described in greater detail  
5 below. The signal processor 162 provides a control output 168 whose output level indicates the presence of a user (output level = logic one) or the absence of a user (output level = logic zero).

An optional driver circuit 164 is also provided in the power management unit 150 for embodiments where the output current that can be provided by the control output 168  
10 is not sufficient to drive field-effect transistor (FET) switch 166 directly. The FET switch 166 is operable to electrically couple the positive supply rail 124 to the portion of the positive supply rail 124' in order to activate electrical components connected to the latter supply rail 124'. Where such a driver circuit 164 is provided, it is itself  
15 powered by drawing power from between the positive supply rail 124 and the negative supply rail 126.

Optionally, the charge sense circuit 152 and the signal processor 162 may be provided together by using an integrated circuit (IC) device, such as, for example, the QT110 sensor IC available from Quantum Research Group of Hamble, Great Britain.

Figure 5 shows a charge transfer capacitance measurement circuit 155. A similar  
20 charge transfer capacitance measurement circuit is described in US patent number US-B1-6,466,036 [5], and the content of this document is hereby incorporated herein by reference in its entirety.

Although any suitable capacitance measurement technique may be used, the circuit of the charge transfer capacitance measurement circuit 155 is well suited for  
25 implementing on an IC. Additionally, the measuring of capacitance using a charge transfer technique can be advantageous because it provides superior performance at a lower manufacturing cost when compared to various other user presence detection techniques.

A first switching element, S1, is used to drive electric charge through both a sampling capacitor, Cs, and a capacitance to be measured, Cx, during Step C (as summarised in the table of Figure 6). This leaves residual charges on both Cs and Cx after S1 opens in step D of Figure 6. Kirchoff's current law and the principle of charge conservation dictate that these charges, Qx and Qs, are equal. However, because  $C_s \gg C_x$ , a greater residual voltage is found on Cx, and conversely, a lesser voltage is found on Cs. Figure 7 reveals that the arrangement of Figure 5 may be viewed as a capacitive voltage divider when considering the closure of S1 in step C of Figure 6.

In Figure 5, a sense plate 160 is explicitly depicted to indicate that in uses of the invention the presence or motion of an object that is not part of the apparatus of the invention is to be sensed by a capacitive measurement. Although the Figures sometimes show both a sense plate 160 and an unknown capacitance, Cx, it will be understood to those skilled in the art that in these depictions Cx is the capacitance of the sense plate 160 to free space or to an electrical ground. The value of Cx is modified by the presence or proximity of a user.

Again referring to the depiction of Figure 5, a second switching element, S2, is used to clear the voltage and charge on Cx, and also to allow the measurement of Vcs, the voltage across Cs. It may be noted that the use of S2 allows S1 to be cycled repeatedly in order to build up the charge on Cs. This provides a larger measurable voltage value and greater accuracy, increasing sense gain or sensitivity without the use of active amplifiers. A third switching element, S3, acts as a reset switch and is used to reset the charge on Cs prior to beginning a charge transfer burst as explained below.

A preferred control circuit 172 controls the switching sequence and also the operation of the measurement circuit 170. The control circuit 172 is operable to switch the switches S1, S2 and S3 using the schematically-illustrated control lines 174. A signal processor, indicated as block 162, may be required to translate an output of the measurement circuit into a usable form. For example, this may involve converting cycle counts to a binary representation of signal strength. The signal processor 162 may also contain linear signal processing elements such as filters and/or non-linear

functions such as threshold comparisons, so as to provide an output suitable for an intended application.

Although the control circuit 172 and signal processor 162 are depicted only schematically in Figure 5, it will be clear to those skilled in the art that such circuit  
 5 elements may also be used with circuit elements depicted elsewhere (e.g. as indicated by the bold output arrow from the measurement circuit 170), and that various circuit elements and connections have been omitted only in the interest of clarity of presentation.

The table of Figure 6 shows the switching sequence used in one implementation using  
 10 the circuit of Figure 5. First, in step A, switching elements S2 and S3 are closed to clear charge on Cs and Cx. After a suitable pause in step B during which all switches are held open, S1 is closed to drive charge through Cs and Cx (Step C). The resulting first voltage increment across Cs is defined by the capacitive divider equation:

$$\Delta V_{Cs(1)} = V_r C_x / (C_s + C_x) \quad (1)$$

15 where  $V_r$  is the reference voltage connected to S1.

In step D, all switches are held open.

In Step E, S2 is closed, and  $\Delta V_{Cs}$  appears as a ground-referenced signal on the positive, distal, terminal of Cs. Dead-time steps B and D are employed to prevent  
 20 switch cross-conduction, which would degrade the charge build-up on Cs. The dead-time can be quite short, measuring a few nanoseconds, or longer if desired. Steps B through E may be repeated in a looping manner, to provide a "burst" of charge transfer cycles. After a suitable charge transfer burst length, the charge transfer cycle is terminated and  $V_{Cs}$  is measured in the aforementioned manner, e.g. by using an  
 25 analogue-to-digital converter (ADC), in Step F, with S2 closed and the other switches open. Following the measurement of  $V_{Cs}$ , S3 may also be closed to reset Cs in preparation for the next charge transfer burst, during which a further plurality of packets of charge will be transferred from Cx to Cs.

In an alternative variant, steps E and F may be combined so that a measurement is made at each charge transfer cycle. By combining steps E and F, which are functionally identical, the measurement circuit 170 can be made to consist of a simple voltage comparator with a fixed reference. In such cases, the looping action of the charge transfer cycles is terminated when the voltage comparison indicates that  $V_{cs}$  has risen above a selected threshold value. The number of cycles taken to reach this point becomes the signal reading which is indicative of the value of the capacitance  $C_x$ . This technique is explained further below.

During the repeating loop of steps B through E, voltage builds up on  $C_s$  but not on  $C_x$ .  $C_x$  is continuously being discharged in step E, and hence  $C_x$  cannot build up an increasing amount of charge. However,  $C_s$  freely accumulates charge, so that the resulting incremental voltage is dependent on the difference in the voltages  $V_r$  and  $V_{cs}$  as follows:

$$\Delta V_{cs}(n) = K(V_r - V_{cs}(n-1)) \quad (2)$$

where  $V_r$  is a supply voltage that may be a fixed reference voltage;  $n$  is the charge transfer cycle number; and  $K = C_x / (C_s + C_x)$ .

The final voltage across  $V_{cs}$  is equal to the sum of the initial value of  $V_{cs}$  plus  $V_{cs}(N)$  which is equal to the sum of all of the subsequent values of  $\Delta V_{cs}$ . That is:

$$V_{cs}(N) = \Delta V_{cs}(1) + \Delta V_{cs}(2) + \Delta V_{cs}(3) + \dots + \Delta V_{cs}(N) \quad (3)$$

or,

$$V_{cs}(N) = \sum \Delta V_{cs}(n) = K \sum (V_r - V_{cs}(n-1)) \quad (4)$$

where the summation runs over the range from  $n=1$  to  $n=N$ .

During each charge transfer cycle, the additional incremental voltage on  $V_{cs}$  is less than the increment from the prior cycle and the voltage build-up can be described as a limiting exponential function:

$$V(N) = V_r - V_r e^{-dn} \quad (5)$$

where  $d$  is a time scaling factor. This produces the profile that is shown in Figure 8.

In practice, a burst is terminated well before  $V_{cs}$  rises to be approximately the same as  $V_r$ . In fact, if the rise in  $V_{cs}$  is limited to  $<10\%$  of  $V_r$ , the linearity can be made acceptable for most applications. For simple limit sensing applications,  $V_{cs}$  can be  
5 permitted to rise higher, at the expense of increasingly degraded signal-to-noise ratios in the threshold comparison function.

The charge transfer burst can be terminated after a fixed or after a variable number of cycles. If a fixed number is used, the measurement circuit 170 should be capable of representing continuous signals much as in the fashion of an ADC or an analogue  
10 amplifier. If a variable burst length is used, a simple comparator with a fixed reference can be employed for the measurement circuit 170, and the length of the burst required is that at which  $V_{cs}$  has built up to a level where it equals the comparison voltage. The burst can continue beyond the required number, but the extra charge transfer cycles are superfluous. A count of the charge transfer cycles required to achieve the comparison  
15 voltage is the output result, and for all practical purposes is indistinguishable from an ADC result. Such a result may be obtained by repeating the switching sequence of Figure 6, including a number of loop cycles, in order to periodically check for the presence of a user (e.g. once per second).

Note that in Figure 5 the measurement circuit 170 is connected to the (+), distal, side  
20 of  $C_s$ , and the reading is taken when  $S_2$  is closed. Although the (+) side of  $C_s$  is the most convenient measurement point for a ground-referenced signal, it is also possible to measure  $V_{cs}$  on the (-), proximal, side of  $C_s$  by holding  $S_1$  closed instead of  $S_2$ . The reading is then  $V_r$ -referenced instead of ground referenced, which those skilled in the art will recognise as being generally inferior but still possible. In either case, the  
25 measurement being made is the *de facto* value of  $V_{cs}$ . Whether the reading is made with respect to ground or  $V_r$  is irrelevant to the invention, what is important is the differential voltage across  $C_s$ .

Although Figure 5 describes the use of a measurement circuit 170, those skilled in the art will realise that this is only one way of putting the invention into effect and that use

of such a measurement circuit is not essential in order to implement alternative embodiments of the invention.

Various optional improvements can be made to the charge transfer capacitance measurement circuit 155 by incorporating additional post-acquisition algorithms into the processing capability of the signal processor 162. Examples are:

1. A drift compensation mode, in which the circuit 155 can continuously adjust its threshold in accordance with slow changes that affect signal strength. These changes may include temperature fluctuations, moisture build-up, or mechanical creep, etc. This can be accomplished by altering one or more reference level slowly at a slew-rate limited rate when no detection is being sensed.
2. Incorporation of hysteresis, in which in order to prevent 'contact bounce' the circuit 155 can incorporate detection threshold hysteresis so that the initiation detection level is different, i.e. higher, than the non-detection level, thus requiring the signal to transit through a lower signal level than the threshold level before a 'no detect' state is entered.
3. Incorporation of a consensus filtering function into the charge transfer capacitance measurement circuit 155. This feature can be provided by one or more comparators acting to compare the measured capacitance value to a predetermined threshold value. It can also be provided by the signal processor 162 sequentially comparing the measured capacitance value to a threshold value multiple times. A poll of the results is obtained and the consensus as to whether the measured capacitance value is above or below the threshold value is accepted as the final result. This feature reduces the amount of false triggering of the charge transfer capacitance measurement circuit 155 when detecting the presence or absence of a user, and consequently improves the reliability of the power management unit 150.

The above numbered optional features may be provided by various algorithms encoded in the signal processor, for example. They are also useful in various combinations and degrees in conjunction with various of the circuits described herein, to provide a more



robust sensing solution that can adapt to a variety of real-world sensing challenges, such as dirt accumulation, the presence of moisture, thermal drift, etc.

Figure 9 schematically shows an apparatus according to another embodiment of the invention. The apparatus is a portable music player and comprises a headset 180 which  
5 includes a flexible lead 202 which allows it to be connected to a base unit 182. The apparatus is configured so that playback of an audio signal is automatically paused when a user removes the headset and automatically restarted when a user re-dons the headset.

The headset in this example is a stereo headset and comprises two audio speakers (not  
10 shown) located within respective first 186 and second 188 ear-piece housings. The ear-piece housings 186, 188 are designed to be worn in a user's ear so that the user can hear audio from the speakers. Within the first ear-piece housing 186 is a sensing element in the form of an electrically conducting sense plate 196. The sense plate in this example is a metal ring located adjacent an internal surface of the ear-piece  
15 housing 186. The audio speakers in the ear-piece housings are connected to the base unit 182 via wiring within flexible lead 202 and removable jack plug 200 using generally conventional techniques. However, the flexible lead 202 and jack plug 200 are also configured to establish an electrical connection between the sense plate 196 and the base unit 182 via sense plate connector wire 197.

20 The base unit 182 comprises a housing 192, user accessible control buttons 194 for allowing a user to provide inputs to govern aspects of the operation of the apparatus, control circuitry (also referred to as controller) 204, capacitance measurement circuitry 205 and an audio signal generator 190. In this case the base unit 182 is a hard-disk based audio player and the audio generator 190 comprises a hard-disk 206 for storing  
25 audio files and associated drive and read circuitry 208 and amplifier circuitry 210. The amplifier circuitry supplies signals to the speakers in the ear-piece housings via the wiring in the jack plug 200 and flexible lead 202 to allow the audio files to be played to a user.

In use, a user inserts the ear-pieces 186, 188 of the headset 180 into his respective ears and, using the control buttons 194, instructs the base unit 182 to play a desired audio track to be supplied to the speakers in the ear-pieces. This is achieved in a substantially conventional manner. I.e., the control circuitry 204 responds to inputs from the control  
5 buttons to configure the hard-disk drive 206 and read circuitry 208 appropriately to play back the desired audio track through the amplifier circuitry 210, to the speakers via jack plug 200 and flexible lead 202.

The sense plate 196 is connected to the capacitance measurement circuit via sense plate connector wire 197. During operation, the capacitance measurement circuitry  
10 monitors the capacitance of the sense plate 196, e.g. to a system ground or other reference potential. This can be done using any known capacitance measurement technique. For example, the capacitance measurement circuitry 205 could be based on charge transfer (as described above), measuring the time constant of an RC circuit including the sense plate, or other techniques, such as those based on relaxation  
15 oscillators, phase shift measurements, phase locked loop circuitry, capacitive divider circuitry, and so on, as are known in the art. The capacitance measurement circuitry may be configured to continually monitor the capacitance of the sense plate 196, or to take readings less often, for example once every five seconds or so.

The capacitance measurement circuitry 205 is configured to supply a capacitance  
20 measurement signal representing the measured capacitance to the control circuitry 204. On receipt of the capacitance measurement signal, the control circuitry compares it with a stored threshold level  $C_{th}$  which relates to the capacitance of the sense plate as measured when the headset is not being worn. If the measured capacitance is less than the threshold level it is assumed that the headset is not being worn. If, on the other  
25 hand, the measured capacitance is greater than the threshold level, it is assumed that the head set is being worn on the basis that, as described above, the presence of the user has increased the measured capacitance of the sense plate. Thus the threshold corresponds to the capacitance of the sense plate as measured when the headset is not being worn plus a margin to account for noise and variations in measured capacitance  
30 not associated with the presence of a user. If an average measured capacitance of  $C_{no}$  is expected when the headset is not being worn, and an average measured capacitance of

$C_{yes}$  is expected when the headset is being worn, the threshold may, for example, be set midway between  $C_{no}$  and  $C_{yes}$ .

Thus depending on whether the measured capacitance exceeds the threshold level, the controller can determine whether or not the headset is being worn and activate or disable functions of the apparatus as appropriate (i.e. in accordance with how it has been programmed to operate). In this case, if the measured capacitance is less than the threshold level  $C_{th}$  so that it is determined the headset is not being worn, the controller instructs the drive and read circuitry in the audio generator to pause playback.

The operation of the apparatus may be controlled in stages depending on the duration over which the capacitance is measured to be less than the threshold. For example, during the initial pause in playback, the apparatus may continue to be fully powered, with the hard disk continuing to spin, and so on. However, if after a given period of time, for example, 30 seconds, the measured capacitance is still less than the threshold level  $C_{th}$ , the control circuitry may instruct the read and drive circuitry to stop the hard-disk from spinning, e.g., to reduce wear. If after another period of time, for example, another 30 seconds, the measured capacitance remains less than the threshold level  $C_{th}$ , the control circuitry may then instruct the read and drive circuitry and the power amplifier to enter a power saving mode. After yet a further period of time, for example a further minute or two, if the measured capacitance still remains less than the threshold level  $C_{th}$ , the controller may be configured to fully power down the apparatus on the assumption that the user has permanently stopped listening to it.

If at any stage the measured capacitance rises above the threshold level  $C_{th}$ , the controller determines that a user has re-donned the headset, and playback continues from the point at which it was initially paused. Thus the user is provided with continued playback of an audio track without requiring him to control the apparatus himself.

For ease of explanation, the control circuitry 204, the capacitance measurement circuitry 205 and the drive and read and amplifier circuitry in the audio generator 190 are shown as discrete elements in Figure 9. However, it will be understood that the

functionality of some or all of these circuit elements could be provided by a single integrated circuit. For example, an application specific integrated circuit (ASIC), or a suitably programmed micro-processor could be used. Thus, the division of the above described circuitry functions among integrated circuit components is not significant.

5 For example, the comparison between an analogue representation of the measured capacitance and a threshold level may occur within the capacitance measurement circuitry, with the capacitance measurement circuitry then supplying a binary signal to the control circuitry to indicate whether or not the capacitance exceeds a threshold.

10 Furthermore, it will be appreciated that rather than rely on a threshold level based on an absolute measure of capacitance, the control circuitry may be configured to determine when a user puts on or removes the headset based on changes in measured capacitance. This has the advantage of accommodating drifts in the measurement, e.g. associated with changes in environmental conditions. For example a significant increase in measured capacitance from one measurement to the next (or occurring over  
15 a given time period such as a few seconds, depending on the rate at which measurements are made) would be associated with a user putting on the headset. Conversely, a significant decrease in measured capacitance from one measurement to the next (or over a given time period) would be associated with a user removing the headset. A significant increase/decrease might be deemed to be a change of 50% or  
20 more of the expected difference in measured capacitance between the headset being worn and not worn, for example.

It will also be appreciated that the same techniques can be applied to many other apparatuses. For example, rather than the base unit being a hard-disk based audio player, the apparatus might be a CD player, an audio cassette player, a radio, a DVD  
25 player, a mobile telephone, a solid state based audio player, or any other apparatus that may be associated with providing an audio signal to a headset.

30 Furthermore, in some embodiments the headset itself may include all of the necessary circuitry such that no separate base unit is required. This is likely to be impractical for some apparatuses, for example CD players, but may be useful for other devices, such as solid state music players, mobile phone headsets and so on. In some cases, a base

unit may be used, but aspects of the above described circuitry nonetheless be located in the headset. For example, the capacitance measurement circuitry may be located in the headset if there is a concern that the lead to the sense plate would cause too much pick-up for reliable capacitance measurement.

5 What is more, in addition to (or instead of) pausing the playback, the invention can be used to control many other functions of an apparatus. For example, the control circuitry may be configured to automatically route audio signals to an external amplifier driving conventional (i.e. not headset) box speakers when the headset is removed. In another example, the control circuitry may be configured to inhibit  
10 response to user inputs depending on whether the headset is being worn. For example, if the headset is not being worn, a button for switching on the apparatus may be inhibited to prevent accidental activation when in a user's pocket or bag. Alternatively, some control buttons, e.g. an increase volume button, may be inhibited when the headset is being worn to prevent accidentally increasing volume to an uncomfortable  
15 level.

The headset need not be stereo, but could be monaural. Where it is stereo, sense plates could be incorporated in the headset in association with both of a user's ears, if desired. This could allow an apparatus to respond to one or other (or both) ear-piece housings from being removed from a user's head. For example, the apparatus might  
20 pause if any one ear-piece is removed, or only if both are removed. Furthermore, the function to be controlled could depend on which ear-piece (speaker housing) is removed. For example, if a left-ear ear-piece is removed, the audio signal to the speaker in that ear-piece could be stopped while the other was maintained.

It will be understood that the communication (both of audio signals and capacitance  
25 measurement related signals) between the headset and the base unit (in embodiments where there is one) could be established wirelessly rather than through a flexible lead and jack plug as shown in Figure 9. For example, any of the communications protocols described above could be used.

Figures 10A and 10B are schematic diagrams of an apparatus used to describe a further embodiment of the invention.

Figure 10A shows a wireless ear-mounted single-ear headset 300 of the kind offered currently as Bluetooth™ transceivers. These are widely used with mobile telephones, home-use cordless telephones connected to landlines or internet telephony connections as well as with other equipment, for example software applications running on a personal computer. The headset 300 has a housing 301 which includes: an earclip 293 for fitting the device over a user's ear; a loudspeaker 290 for aural communication with a user's ear; and a microphone 295 for receiving speech signals from the user.

Within the housing 301 proximate the ear clip 293 there is a sensing element in the form of an electrically conducting sense plate 296. The sense plate in this example is a metal ring located adjacent an internal surface of the ear-piece housing so as to be close to the user's skin. The sense plate 296 supplies a capacitive signal to capacitance measurement circuitry 305 which in turn supplies a user presence signal to control circuitry 304 which is connected to the device's wireless transceiver 297 as well as to the audio transmitter and receiver elements of the device, namely the audio signal generator 290 and microphone 295.

During operation, the capacitance measurement circuitry 305 monitors the capacitance of the sense plate 296, e.g. to a system ground or other reference potential. This can be done using any known capacitance measurement technique, as mentioned above with reference to the example of Figure 9. The example of Figure 9 is also referred to in respect of further details of the configuration of the device including the use of thresholds.

A concrete example of the use of the wireless headset device of Figure 10A is described in conjunction with Figure 10B.

Figure 10B shows schematically a mobile phone or cell phone 310. (This could equally well be a cordless landline phone or internet telephony phone.) The phone 310 has a housing 311. On one side a display 314 and keypad 316 are evident. The display or keypad, or both, may have an integral two-dimensional capacitive touch sensor, for

example for text messaging input of Chinese, Japanese, Korean or other language characters. The phone 310 further includes a wireless transceiver 320 for communicating with peripheral devices, such as Bluetooth™ devices. An antenna 318 for transmitting and receiving signals to and from a mobile phone base station is also  
5 illustrated. The phone 310 also includes a loudspeaker 312 for transmitting speech signal to a user's ear and a microphone 313 for receiving speech signals from a user.

Use of the headset of Figure 10A in conjunction with the phone of Figure 10B is now described.

10 If a communication channel is established between the headset and the phone, then the audio transmission and reception (loudspeaker and microphone) is switched between the headset and the phone dependent on the user presence signal in the headset. If the user presence signal indicates the headset is being worn, then the audio circuits of the headset are activated and those of the phone deactivated. Conversely, if the user presence signal indicates the headset is not being worn, then the audio circuits of the  
15 headset are deactivated and those of the phone activated. This can provide savings in power consumption. It can also suppress feedback interference that might otherwise occur. Moreover, it can divert the phone's ring tone to the headset if the headset is being worn, and suppress the ring tone from the phone. This mode of operation may be useful in an environment where it is not permitted, or impolite, to allow mobile phone  
20 ring tones, such as an auditorium, restaurant or train. If the user presence signal indicates the headset is being worn, further power consuming circuits of the phone may be deactivated also, either by switching them to a lower power standby mode or more fully powering down. For example, the display backlight could be switched off, or sensing circuitry of a two-dimensional capacitive touch sensor array associated with  
25 the display or keypad could be powered down.

It will be appreciated the headset may operate similarly with a plethora of other devices in addition to the phone example just described.

While the invention is susceptible to various modifications and alternative forms, specific embodiments are shown by way of example in the drawings and are herein described in detail. Accordingly, the skilled man will be aware that many different embodiments of the invention are possible. It should thus be understood that the drawings and corresponding detailed description are not intended to limit the invention to the particular form disclosed, but on the contrary, the invention is to cover all modifications, equivalents and alternatives falling within the spirit and scope of the present invention as defined by the appended claims.

For example, the skilled man would be aware that capacitive sensing may entail use of a sensor circuit for measuring the absolute or relative capacitance of a two-leaded capacitor or of a free-space sense plate, and for providing as an output, a measurement of the capacitance in any usable form. For example, a device only capable of generating a single-bit thresholded "detect" output would still be considered a sensor circuit for the purposes of this disclosure.

The skilled man would also be aware that a capacitive sensor may be located remotely from a headset. For example, a capacitive sensor may be provided on an electronic device, such as a mobile telephone, to which the headset is operably coupled.

In addition, the skilled man would be aware that various of the switches described herein may be implemented using an electronically controlled switch, such as, for example, by way of a bipolar or field effect transistor, a relay, an opto-electronic device, or any functionally similar circuit. He would also be aware that a controller or control circuit may comprise a circuit or system capable of generating digital control signals. Such a controller or control circuit may control a capacitance measurement circuit sensor (including control of switching elements therein) and the measurement circuit, and may generate a decision output if required. Such controllers or control circuits may comprise digital logic means such as a programmable logic array or a microprocessor, for example.

Those skilled in the art will also be aware that headsets according to the present invention need not necessarily be cordless devices that incorporate receivers and



transmitters, or merely receivers, whether they be Bluetooth™ enabled or otherwise. Moreover, they will also be aware that various embodiments of the invention may be wearable by a user in proximity to only a single ear, and not require the use of stereo loudspeakers.

**References**

1. GB-A-1,483,829
2. US-5,678,202
3. US-B1-6,356,644
- 5 4. JP2000278785 A
5. US-B1-6,466,036

**CLAIMS:**

1. An apparatus comprising:  
a headset including a sensing element;  
5 a capacitance measurement circuit operable to measure the capacitance of the sensing element; and  
a control circuit operable to determine whether a user is wearing the headset based on a measurement of the capacitance of the sensing element, and to control a function of the apparatus according to whether the headset is being worn.  
10
2. The apparatus of claim 1, wherein the capacitance measurement circuit includes a sample capacitor and is further operable to transfer charge from the sensing element to the sample capacitor to generate an electric potential at the sample capacitor for measuring.  
15
3. The apparatus of claim 2, comprising at least one switch operable to transfer a burst of charge packets sequentially from the sensing element to the sample capacitor prior to a measurement of the electric potential being made.
- 20 4. The apparatus of claim 1, 2 or 3, wherein the control circuit is operable to determine whether a user is wearing the headset by comparing a measured capacitance of the sensing element to at least one predetermined threshold value.
- 25 5. The apparatus of any of claims 1 to 4, wherein the sensing element comprises an electrode that is electrically isolated from the user when the headset is being worn.
6. The apparatus of any of claims 1 to 5, wherein the capacitance measurement circuit is internal to the headset.
- 30 7. The apparatus of claim 6, wherein the control circuit is internal to the headset.

8. The apparatus of claim 7, wherein the function to be controlled is provided by a circuit element which is internal to the headset.
9. The apparatus of any of claims 1 to 8, wherein the function to be controlled is provided by a circuit element which is external to the headset.
10. The apparatus of claim 9, wherein the control circuit is external to the headset.
11. The apparatus of claim 10, wherein the capacitance measurement circuit is external to the headset.
12. The apparatus of any of claims 1 to 11, wherein the function to be controlled is a power saving function.
13. The apparatus of any of claims 1 to 11, further comprising an audio amplifier for supplying audio signals to speakers in the headset, and wherein the function to be controlled is the activation of the audio amplifier.
14. The apparatus of any of claims 1 to 11, further comprising a wireless communications transceiver, and wherein the function to be controlled is the activation of the wireless communications transceiver.
15. The apparatus of any of claims 1 to 11, further comprising an audio generator for outputting an audio signal, and wherein the function to be controlled is the outputting of an audio signal by the audio generator.
16. The apparatus of any of claims 1 to 11, further comprising input buttons for supplying operating signals to the control circuit to allow a user to govern the operation of the apparatus, and the function to be controlled is the inhibition of signals from the input buttons.

17. A method of operating an apparatus comprising a headset, the method comprising:

measuring the capacitance of a sensing element in the headset;

determining from the measured capacitance whether a user is wearing the headset; and

controlling a function of the apparatus in response to determining whether the headset is being worn.

18. The method of claim 17, wherein measuring the capacitance of the sensing element includes:

transferring charge from the sensing element to a sample capacitor;

measuring the electric potential at the sample capacitor; and

determining the capacitance of the sensing element from the measured electric potential of the sample capacitor.

15

19. The method of claim 18, wherein transferring charge from the sensing element to a sample capacitor comprises transferring a burst of charge packets in sequence from the sensing element to a sample capacitor.

20. The method of claim 17, 18 or 19, wherein determining whether a user is wearing the headset or not comprises comparing the measured capacitance of the sensing element to at least one predetermined threshold value in order to determine whether the capacitance of the sensing element has been changed due to the proximity of a user.

25

21. The method of claim 20, comprising adjusting one or more of the threshold values in response to changes in operating conditions.

22. The method of any of claims 17 to 21, wherein the controlling a function of the apparatus comprises controlling whether or not the apparatus is in a power saving mode.

30

23. The method of any of claims 17 to 21, wherein the controlling a function of the apparatus comprises controlling whether or not wireless communications transceiver is activated.
- 5 24. The method of any of claims 17 to 21, wherein the controlling a function of the apparatus comprises controlling whether or not an audio signal generator is activated.
25. The method of any of claims 17 to 21, wherein the controlling a function of the apparatus comprises controlling whether or not user inputs for governing the operation  
10 of the apparatus are inhibited.
26. A headset comprising:  
at least one circuit element;  
a capacitive sensor operable to provide a capacitance measurement signal; and  
15 a sensing circuit operable to generate a user presence signal responsive to the capacitance measurement signal indicating whether the headset is being worn and operable to control the at least one circuit element dependent on said user presence signal, or to output an external output signal that is dependent on said user presence signal for receipt by another device to which the headset is connected.
- 20 27. The headset of claim 26, wherein the sensing circuit includes a sample capacitor and is further operable to transfer charge from the capacitive sensor to the sample capacitor to generate an electric potential at the sample capacitor for measuring.
- 25 28. The headset of claim 27, comprising at least one switch operable to transfer a burst of charge packets sequentially from the capacitive sensor to the sample capacitor prior to any measurement of the electric potential being made.
- 30 29. The headset of claim 26, 27 or 28, wherein the sensing circuit comprises a consensus filter for generating the user presence signal.

30. The headset of any of claims 26 to 29, wherein the sensing circuit is further operable automatically to perform a self-calibration operation.
31. The headset of any of claims 26 to 30, wherein the capacitive sensor comprises  
5 an electrode that is electrically isolated from the user when the headset is being worn.
32. The headset of any of claims 26 to 31, wherein at least one of the circuit elements comprises a wireless communications transceiver.
- 10 33. The headset of any of claims 26 to 32, further comprising a power management unit, of which the sensing circuit is a part, and wherein the power management unit is operable to reduce power consumption of the at least one circuit element dependent on said user presence signal, thereby to reduce power consumption of the headset.
- 15 34. A method of operating a headset in order to reduce power consumption, the method comprising:  
measuring the capacitance of a capacitive sensor;  
determining from the measured capacitance whether a user is present or not;  
and  
20 powering down one or more circuit elements in the headset in response to determining that no user is present in order to reduce the power consumption of the headset.
- 25 35. The method of claim 34, wherein measuring the capacitance of the capacitive sensor includes:  
transferring charge from the capacitive sensor to a sample capacitor;  
measuring the electric potential at the sample capacitor; and  
determining the capacitance of the capacitive sensor from the measured electric  
30 potential of the sample capacitor.

36. The method of claim 35, wherein transferring charge from the capacitive sensor to a sample capacitor comprises transferring a burst of charge packets in sequence from the capacitive sensor to a sample capacitor.
- 5 37. The method of claim 34, 35 or 36, wherein determining whether a user is present or not comprises comparing the measured capacitance of the capacitive sensor to one or more predetermined threshold values in order to determine whether the capacitance of the capacitive sensor has been changed by the proximity of the user.
- 10 38. The method of claim 37, comprising adjusting one or more of the threshold values in response to changes in operating conditions.
39. A method of operating a headset, the method comprising:  
measuring the capacitance of a capacitive sensor;  
15 determining from the measured capacitance whether a user is present or not;  
and  
controlling a function of the headset, or outputting an external output signal that can be received by another device to which the headset is connected, in response to determining whether the user is present or not.
- 20 40. The method of claim 39, wherein measuring the capacitance of the capacitive sensor includes:  
transferring charge from the capacitive sensor to a sample capacitor;  
measuring the electric potential at the sample capacitor; and  
25 determining the capacitance of the capacitive sensor from the measured electric potential of the sample capacitor.
41. The method of claim 40, wherein transferring charge from the capacitive sensor to a sample capacitor comprises transferring a burst of charge packets in  
30 sequence from the capacitive sensor to a sample capacitor.



42. The method of claim 39, 40 or 41, wherein determining whether a user is present or not comprises comparing the measured capacitance of the capacitive sensor to one or more predetermined threshold values in order to determine whether the capacitance of the capacitive sensor has been changed by the proximity of the user.

5

43. The method of claim 42, comprising adjusting one or more of the threshold values in response to changes in operating conditions.

44. The method of any of claims 39 to 43, wherein said device to which the headset is connected is connected thereto wirelessly.

10

45. The method of any of claims 39 to 43, wherein said device to which the headset is connected is wired thereto.

46. A headset substantially as hereinbefore described with reference to the accompanying drawings.

15

47. A method of operating an apparatus comprising a headset substantially as hereinbefore described with reference to the accompanying drawings.



For Innovation

30

Application No: GB0618960.9

Examiner: Simon Colcombe

Claims searched: 1-47

Date of search: 22 February 2007

**Patents Act 1977: Search Report under Section 17**

**Documents considered to be relevant:**

Category	Relevant to claims	Identity of document and passage or figure of particular relevance
X,P	1, 17, 26, 34, 39 at least	WO2005/099105 A1 (SONY ERICSSON) Whole document
X,Y	X:1, 17, 26, 39; Y:34, at least	WO03/103175 A1 (MOTOROLA) Whole document
X,Y	X:1, 17, 26, 39; Y:34, at least	US2002/0068537 A1 (MOBIGENCE) Whole document
X,Y	X:1, 17, 26, 39; Y:34, at least	GB2357400 A (NOKIA) Whole document
X,Y	X:1, 17, 26, 39; Y:34, at least	EP0564164 A1 (AT&T) Whole document
Y	34 at least	EP1260082 A1 (ERICSSON) Whole document
A	-	US6466036 B1 (PHILIPP)

**Categories:**

X	Document indicating lack of novelty or inventive step	A	Document indicating technological background and/or state of the art.
Y	Document indicating lack of inventive step if combined with one or more other documents of same category.	P	Document published on or after the declared priority date but before the filing date of this invention.
&	Member of the same patent family	E	Patent document published on or after, but with priority date earlier than, the filing date of this application.

**Field of Search:**





For Innovation

37

Search of GB, EP, WO & US patent documents classified in the following areas of the UKC<sup>x</sup> :

G1N

Worldwide search of patent documents classified in the following areas of the IPC

H03K; H04R

The following online and other databases have been used in the preparation of this search report

WPI, EPODOC

**dbi** ADI SERVICE

(19)



(11)

EP 1 536 314 A3

(12)

EUROPEAN PATENT APPLICATION

(88) Date of publication A3: 10.09.2008 Bulletin 2008/37

(51) Int Cl.: G06F 1/32 (2006.01)

(43) Date of publication A2: 01.06.2005 Bulletin 2005/22

(21) Application number: 04026594.4

(22) Date of filing: 09.11.2004

(84) Designated Contracting States:  
**AT BE BG CH CY CZ DE DK EE ES FI FR GB GR HU IE IS IT LI LU MC NL PL PT RO SE SI SK TR**  
 Designated Extension States:  
**AL HR LT LV MK YU**

(72) Inventor: **Albulet, Mihai Redmond**  
 Washington 98052 (US)

(30) Priority: 25.11.2003 US 720116

(74) Representative: **Grünecker, Kinkeldey, Stockmalr & Schwanhäusser**  
 Anwaltssozietät  
 Leopoldstrasse 4  
 80802 München (DE)

(71) Applicant: **MICROSOFT CORPORATION**  
 Redmond, WA 98052 (US)

(54) **Modifying a power management algorithm based on wireless communication parameters**

(57) A wireless device determines characteristics of a connection established (or being established) with a remote device and implements a power management algorithm based on those characteristics. The wireless device includes a battery power source, a radio transceiver powered by the battery, a memory and a controller. The controller is configured to create, via the transceiver,

wireless connections with remote devices in any of a plurality of connection configurations. The controller detects the presence, in a wireless transmission from a remote device, of one or more parameters identifying one of the plurality of configurations. Based on the configuration identified, the controller implements one of a plurality of power management algorithms.

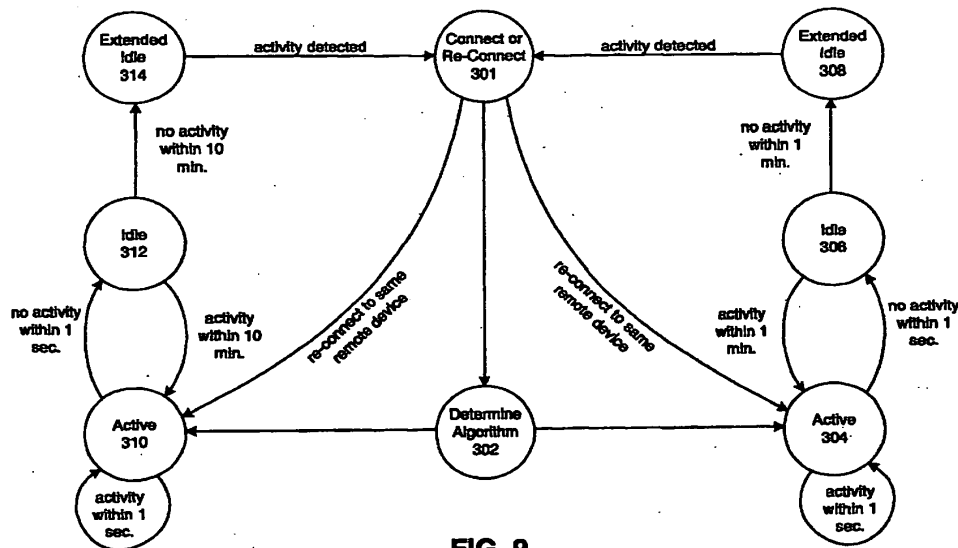

FIG. 9

EP 1 536 314 A3

Printed by Jouve, 75001 PARIS (FR)



European Patent Office

EUROPEAN SEARCH REPORT

Application Number  
EP 04 02 6594

DOCUMENTS CONSIDERED TO BE RELEVANT			
Category	Citation of document with indication, where appropriate, of relevant passages	Relevant to claim	CLASSIFICATION OF THE APPLICATION (IPC)
X	US 2003/197488 A1 (HULVEY ROBERT W [US]) 23 October 2003 (2003-10-23)  * paragraphs [0003], [0010], [0012], [0014], [0035], [0040] - [0042], [0047], [0051] - [0056], [0058], [0066], [0076], [0086] - [0088]; figures 3,6,8,9 *	1,2, 5-11, 14-17, 20,21	INV. G06F1/32
Y	-----	3,4,12, 13,18,19	
D, Y	CRAIG RANTA, STEVE MCGOWAN (BLUETOOTH SIG): "Human Interface Device (HID) Profile v.1.0" BLUETOOTH SPECIFICATION, [Online] 22 May 2003 (2003-05-22), XP002486381 Retrieved from the Internet: URL: <a href="http://www.bluetooth.com/NR/rdonlyres/0BE438ED-DC1B-41D1-AAC0-1AAA956097A2/980/HID_SPEC_V10.pdf">http://www.bluetooth.com/NR/rdonlyres/0BE438ED-DC1B-41D1-AAC0-1AAA956097A2/980/HID_SPEC_V10.pdf</a> [retrieved on 2008-06-30] * pages 39-40, paragraph 6.5.1.3-6.5.1.6 *	3,4,12, 13,18,19	
A	-----	1,2, 5-11, 14-17, 20,21	TECHNICAL FIELDS SEARCHED (IPC) G06F
The present search report has been drawn up for all claims			
Place of search The Hague		Date of completion of the search 11 July 2008	Examiner Trönberg, Carlo
CATEGORY OF CITED DOCUMENTS X: particularly relevant if taken alone Y: particularly relevant if combined with another document of the same category A: technological background O: non-written disclosure P: intermediate document		T: theory or principle underlying the invention E: earlier patent document, but published on, or after the filing date D: document cited in the application L: document cited for other reasons &: member of the same patent family, corresponding document	

13  
EPO FORM 1503 (03.02.04) (P/AC/01)

**ANNEX TO THE EUROPEAN SEARCH REPORT  
ON EUROPEAN PATENT APPLICATION NO.**

EP 04 02 6594

This annex lists the patent family members relating to the patent documents cited in the above-mentioned European search report. The members are as contained in the European Patent Office EDP file on  
The European Patent Office is in no way liable for these particulars which are merely given for the purpose of information.

11-07-2008

Patent document cited in search report	Publication date	Patent family member(s)	Publication date
US 2003197488 A1	23-10-2003	US 2007287381 A1	13-12-2007

EPO FORM P0469

For more details about this annex : see Official Journal of the European Patent Office, No. 12/82



(12) **EUROPEAN PATENT APPLICATION**

(43) Date of publication:  
**01.06.2005 Bulletin 2005/22**

(51) Int Cl.7: **G06F 1/32**

(21) Application number: **04026594.4**

(22) Date of filing: **09.11.2004**

(84) Designated Contracting States:  
**AT BE BG CH CY CZ DE DK EE ES FI FR GB GR**  
**HU IE IS IT LI LU MC NL PL PT RO SE SI SK TR**  
 Designated Extension States:  
**AL HR LT LV MK YU**

(72) Inventor: **Albulet, Mihai**  
**Redmond Washington 98052 (US)**

(74) Representative: **Grünecker, Kinkeldey,**  
**Stockmalr & Schwanhäusser Anwaltssozietät**  
**Maximilianstrasse 58**  
**80538 München (DE)**

(30) Priority: **25.11.2003 US 720116**

(71) Applicant: **MICROSOFT CORPORATION**  
**Redmond, WA 98052 (US)**

(54) **Modifying a power management algorithm based on wireless communication parameters**

(57) A wireless device determines characteristics of a connection established (or being established) with a remote device and implements a power management algorithm based on those characteristics. The wireless device includes a battery power source, a radio transceiver powered by the battery, a memory and a controller. The controller is configured to create, via the trans-

ceiver, wireless connections with remote devices in any of a plurality of connection configurations. The controller detects the presence, in a wireless transmission from a remote device, of one or more parameters identifying one of the plurality of configurations. Based on the configuration identified, the controller implements one of a plurality of power management algorithms.

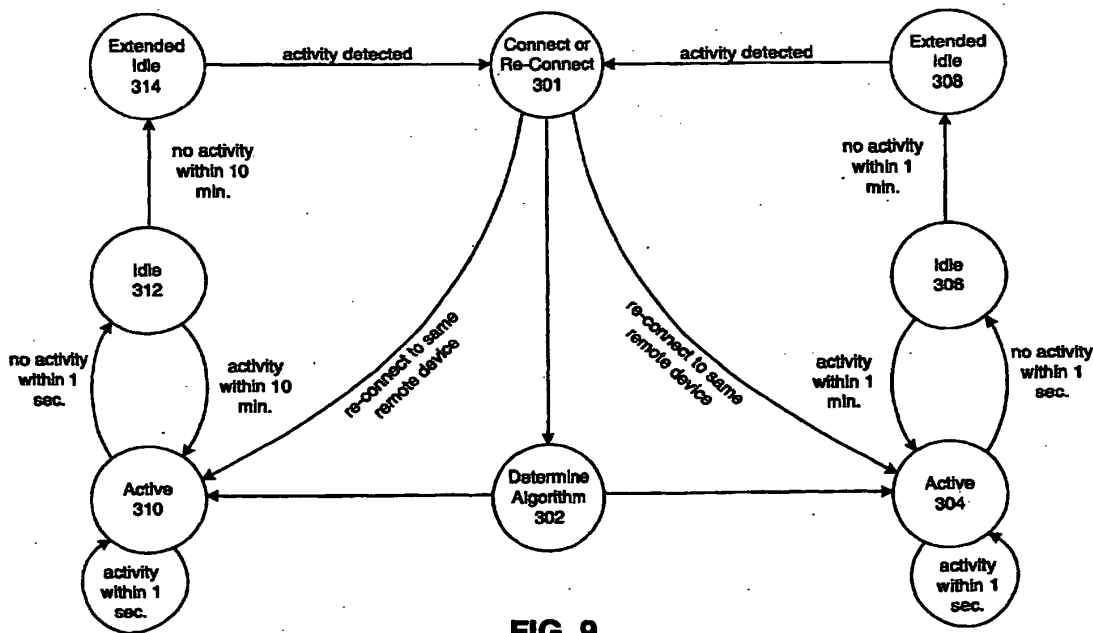

**FIG. 9**

EP 1 536 314 A2

## Description

### FIELD OF THE INVENTION

**[0001]** This invention relates to power management in electronic devices that communicate via a wireless link.

### BACKGROUND OF THE INVENTION

**[0002]** Wireless communication between electronic devices over relatively short distances is a common and increasingly important feature of modern life. In some cases, for example, an electronic device or other appliance is controlled by another electronic device which must communicate instructions to the controlled device (and perhaps receive information from the controlled device). Examples include computer input devices (e.g., mice, trackballs, joysticks, game controllers) and remote control units (for, e.g., televisions or other appliances). In other cases, it is necessary for one electronic device to transmit more complex data to and/or receive such data from another device. Examples include computer keyboards, digital cameras and other devices able to transmit data to a computer or other device. Among other advantages, wirelessly transmitting data and/or control signals can dramatically increase user convenience and reduce clutter from multiple connecting cables.

**[0003]** Although there are several standards for wireless communication, BLUETOOTH is becoming the de facto standard for many applications. Developed by Bluetooth SIG, Inc., the BLUETOOTH wireless specification establishes protocols and standards for two-way wireless communication between electronic devices using relatively low power radio communication. BLUETOOTH is described by, e.g., "Specification of the Bluetooth System" (versions 1.1 and 1.2), "Human Interface Device (HID) Profile version 1.0" and various other documents available from Bluetooth SIG, Inc. at <<http://www.bluetooth.com>>. Among other things, BLUETOOTH provides for two-way radio links between multiple devices in a short-range radio network called a "piconet."

**[0004]** As one example of a BLUETOOTH piconet, a personal computer may be configured to receive input from one or more wireless input devices such as a wireless mouse and/or a wireless keyboard. In some cases, a user connects a device to the piconet by simply bringing the device within range of the computer's Bluetooth controller. In other cases, more steps may be required so that the device becomes bonded with the computer BLUETOOTH host so as to authenticate the device and establish secure communication between the devices. In either case, a series of inquiry, paging and other messages are exchanged between the input device and the computer to set up a connection over which user data (e.g., mouse movement or button press, keyboard key

down, etc.) is transmitted to the computer. In some cases, data from applications or other software executing on the computer is also transmitted over that connection to the input device. Details of the messages exchanged between devices to establish a connection are set forth in the above-referenced BLUETOOTH documents and are known in the art.

**[0005]** To maintain a connection, even when the input device has no user data to transmit, requires a periodic exchange between the input device and the computer. In effect, the input device periodically transmits a message saying "I am still here." The computer responds "OK, you are still on my list," and maintains the connection. Although the interval between user data and/or "I'm here" messages from the input device can be varied, it is generally on the order of tens of milliseconds. If the computer does not receive a message from the input device before expiration of a timeout period, the computer assumes the input device is turned off or absent, and breaks (or "de-lists") the connection with the device. In order for the input device to again communicate with the computer, another series of messages must be exchanged to re-establish the connection.

**[0006]** This can create a conflict with regard to design requirements for a wireless input device such as a computer mouse or keyboard. Because wireless devices are battery powered, it is desirable to reduce the device's power consumption as much as possible so as to prolong battery life. A significant amount of the device power is consumed by the radio transceiver that communicates with the controller. If other considerations are ignored, the period between transmissions should be reduced as much as possible during times when the device is idle, i.e., not actually communicating user data to the computer. If the interval between transmissions is too large, however, the connection to the computer is lost. Although the connection can be re-established, doing so is relatively time-consuming and increases the amount of time needed for user input (e.g., moving a mouse) to cause the appropriate response by the computer (e.g., moving a cursor).

**[0007]** This input-to-response delay, or latency, can be noticeable to a human if it is approximately 100 milliseconds or more. The acceptable amount of perceived latency varies under different conditions and with different users and usage styles. For computers and input devices operating under the earlier version (1.1) of the BLUETOOTH specification, the time to re-establish the connection can be approximately 1 second or more. Under version 1.2 of the BLUETOOTH specification, the reconnect time is reduced, and in some cases may be as little as approximately 250 milliseconds. This is a significant improvement, and may result in acceptable latency in some circumstances. Under other conditions, this may still result in excessive latency. However, the BLUETOOTH specification allows manufacturers to incorporate additional features into a BLUETOOTH-compliant device (whether a computer, an input device or



otherwise), so long as those additional features do not prevent that device from providing certain other features that are mandatory for BLUETOOTH compliance. Accordingly, manufacturers are able to develop BLUETOOTH-compliant chipsets providing a re-connect procedure that is faster than the "default" connection procedure of the BLUETOOTH specification.

**[0008]** Unfortunately, advantages of faster BLUETOOTH version 1.2 and proprietary re-connection procedures may not be achievable in many cases. For example, a computer mouse could be equipped with the hardware and firmware necessary to implement a proprietary fast re-connect procedure, but the mouse might be used with a computer that does not support the fast re-connect procedure. If used with a computer supporting the fast re-connect procedure, the mouse could implement a power-management algorithm that suspends radio communication with the computer for time periods that may cause the mouse-computer radio connection to be broken. Upon need for transmission of data to the computer (e.g., the user moves the mouse after a period of no mouse use), the connection can be re-established sufficiently fast to avoid (or minimize) any perceived latency. If, however, the mouse is used with a computer not supporting a fast re-connect procedure, that power management algorithm would likely result in unacceptable latency.

**[0009]** Various systems and methods are known for automatic detection of a protocol by which a device communicates with a computer. U.S. Patents 6,442,734 and 5,754,890, assigned to the assignee of the present invention, are two examples. However, neither these patents nor other known prior art describes optimizing (or otherwise modifying) a power management algorithm based on parameters of a communication link between devices, and in particular, based on parameters of a wireless communication connection.

#### SUMMARY OF THE INVENTION

**[0010]** Embodiments of the invention allow a wireless device to determine characteristics of a connection established (or being established) with a remote device, and to then implement a power management algorithm based on those characteristics. In one embodiment, a wireless device includes a battery power source, a radio transceiver powered by the battery, a memory and a controller. The controller is configured to create, via the transceiver, wireless connections with remote devices in any of a plurality of connection configurations. The controller detects the presence, in a wireless transmission from a remote device, of one or more parameters identifying one of the plurality of configurations. Based on the configuration identified, the controller implements one of a plurality of power management algorithms.

**[0011]** These and other features and advantages of the present invention will be readily apparent and fully understood from the following detailed description of

preferred embodiments, taken in connection with the appended drawings.

#### BRIEF DESCRIPTION OF THE DRAWINGS

##### **[0012]**

FIG. 1 is a view of a computing system environment implementing at least one embodiment of the invention.

FIG. 2 is a cutaway side view of the wireless mouse of FIG. 1.

FIG. 3 is a block diagram for circuitry of the mouse of FIGS. 1 and 2.

FIG. 4 is a state diagram showing an example power management algorithm.

FIG. 5 is a state diagram showing another example power management algorithm.

FIG. 6 illustrates transmission of a protocol data unit to a wireless mouse.

FIG. 7 illustrates transmission of a protocol data unit to a wireless keyboard.

FIG. 8 is a block diagram for circuitry of a wireless keyboard according to at least one embodiment of the invention.

FIG. 9 is a state diagram for a wireless computer input device according to at least one embodiment of the invention.

FIG. 10 is a state diagram for a wireless computer input device according to another embodiment of the invention.

#### DETAILED DESCRIPTION OF THE PREFERRED EMBODIMENTS

**[0013]** The present invention provides systems and methods by which a wireless device may detect information about a communication link with another device, and then adopt or modify a power management scheme. The invention is described by example of a desktop computer and wireless computer input device communicating under the BLUETOOTH standard. However, the invention is not limited to these specific types of devices or to the BLUETOOTH standard. The invention may also be implemented with numerous other general purpose or special purpose computing system environments or configurations, with other types of devices, and in devices communicating via other wireless communication standards and/or protocols.

**[0014]** FIG. 1 illustrates one example of a suitable computing system environment 1 in which the invention may be implemented. Shown in FIG. 1, in side view, are a desktop computer 2 having a monitor 4 and keyboard 6. Also shown is wireless mouse 100, which communicates with computer 2 via an RF transceiver within dongle 8. Dongle 8 is connected to a USB or other port of computer 2, and is located externally to computer 2 (as shown). In at least one embodiment, dongle 8 houses the required electronic components and firmware for receiving BLUETOOTH communications from and transmitting BLUETOOTH communications to remote devices (such as a mouse or keyboard). In at least one embodiment, components within dongle 8 convert received BLUETOOTH data to a format which may be passed to computer 2 via a USB port, and similarly convert USB data to a format which may be transmitted by BLUETOOTH link. In particular, dongle 8 contains components and firmware needed to implement the radio, baseband, link manager and L2CAP BLUETOOTH layers for computer 2. In other embodiments, electronic components and firmware for implementing BLUETOOTH communications may be internal to computer 2 and directly connected to a system or other bus without an intermediate USB connection.

**[0015]** FIG. 2 is a side, cutaway view of mouse 100. Mouse 100 may have one or more buttons 102 which can be pressed by a user, a scroll wheel 104, or other types of input controls which can be actuated by a user. The number, arrangement and types of input controls shown are merely exemplary, and other combinations and arrangements are within the scope of the invention. The operation of switches, scroll wheels and other types of input controls is known in the art and thus not further described herein. Mouse 100 may also have one or more internal circuit boards 106 or other substrates upon which various electronic components are connected and physically supported.

**[0016]** These components may include an imaging array 108, a LED or laser source 110, a RF antenna 112, a controller 114 and a battery/power source 126. Other components, not shown in FIG. 2, may include memory and other electrical components. LED or laser source 110 emits light which illuminates an area of a desktop or other surface, and which is imaged by imaging array 108. Images from array 108 are then compared to detect movement of mouse 100 across the desktop or other surface.

**[0017]** FIG. 3 is a block diagram of the internal circuitry of mouse 100 according to one preferred embodiment of the invention. Operation of mouse 100 is controlled by a microprocessor ( $\mu$ P) controller 114. Although controller 114 is shown as a microprocessor, controller 114 could alternatively include state machine circuitry or other suitable components capable of controlling operation of mouse 100 as described herein. Controller 114 communicates with memory 116. Memory 116, which may include volatile and non-volatile memory, is a machine-

readable medium used for storage of software (or firmware) instructions, imaging data and configuration settings (such as power management algorithms discussed in more detail below). Memory 116 may include a rewritable non-volatile component, such as battery-backed SRAM or EEPROM, and/or a non-rewritable component such as ROM. Controller 114 also controls LED or laser source 110 (FIG. 2) and imaging array 108 (FIG. 2), as well as other imaging elements, all of which are represented collectively by block 118. Controller 114 further controls RF communication circuitry 120, and passes data to RF communication circuitry 120 for communication to computer 2 over antenna 112 (FIG. 2). Similarly, data communicated to mouse 100 is received via antenna 112 (FIG. 2) and RF circuitry 120, and transmitted to controller 114. Controller 114 communicates with imaging elements 118, RF circuitry 120 and memory 116 over one or more buses 122, shown collectively as bold bi-directional arrows. Controller 114 also receives electrical signals that correspond to a user's actuation of a mouse button 102 (FIG. 2), scroll wheel 104 (FIG. 2) or other input control. These electrical signals are represented collectively by User Input 124. The various electrical components of mouse 100 are powered by a power source 126, which could include one or more batteries.

**[0018]** Although FIG. 3 shows controller 114, imaging circuitry 118, RF circuitry 120 and memory 116 as discrete components, this need not be the case. For example, one or more of these components might be contained in a single Integrated Circuit (IC) or other component. As another example, controller 114 may include internal program memory such as ROM. Similarly, the herein described functions of these components could be distributed across additional components (e.g., multiple controllers or other components).

**[0019]** The present invention permits mouse 100 to automatically implement a power management algorithm based on parameters of a wireless BLUETOOTH connection with computer 2. For purposes of explanation, two simplified power management algorithms are presented. It is understood, however, that devices according to other embodiments of the invention may have additional and/or more complex power management algorithms.

**[0020]** First power management algorithm 200 is shown in the state diagram of FIG. 4. In Active state 202, mouse 100 is configured for immediate use. In other words, Active state 202 assumes that the user is currently moving the mouse, pressing mouse buttons or otherwise providing input to computer 2 with mouse 100. Controller 114 causes LED 110 (FIG. 2) and imaging array 108 (FIG. 2) to create images at a rapid rate. Controller 114 also causes RF circuitry 120 to transmit periodic messages to computer 2 (via dongle 8) containing data or to maintain the connection with computer 2.

**[0021]** After 1 second of no user activity, mouse 100 transitions to Idle state 204. As used herein, "no activity"

includes circumstances when a user is not using the mouse to provide user data to computer 2. In other words, a user is not moving the mouse, pressing a mouse button or rotating a scroll wheel. In some embodiments, mouse 100 is equipped with a proximity sensor (not shown) able to detect the presence of a user hand on or near mouse 100. In such an embodiment, mouse 100 could be configured to treat non-proximity of a user hand as a "no activity" condition. In Idle state 204, Controller 114 causes LED 110 (FIG. 2) and imaging array 108 (FIG. 2) to create images at a reduced rate. Controller 114 also reduces the rate at which RF circuitry 120 transmits messages to computer 2. In particular, messages are only transmitted at an interval sufficiently short to ensure that latency is not noticeable if the user moves mouse 100, pushes a mouse button or otherwise resumes use of mouse 100. Because mouse 100 is in Idle state 204, there is no user data to transmit to computer 2. If there is mouse motion or other user activity while in Idle state 204, the corresponding user data is sent in the next scheduled Idle state transmission, after which mouse 100 returns to Active state 202. In one embodiment, RF messages are transmitted to computer 2 at the rate of one message every 70 milliseconds in Idle state 204. If mouse 100 senses activity (e.g., movement, button press, hand proximity) within 10 minutes after entering Idle state 204, mouse 100 returns to Active state 202. After 10 minutes of no activity, mouse 100 enters Extended Idle state 206. Upon entering Extended Idle state 206, controller 114 sends a message to dongle 8 terminating the connection; in other embodiments, dongle 8 terminates the connection with mouse 100 after mouse 100 has been in Extended Idle state 206 (and therefore not transmitted) longer than the timeout period of dongle 8. In Extended Idle state 206, controller 114 deactivates RF circuitry 120 and no longer transmits to (or listens for transmissions from) computer 2. The imaging rate is also further reduced. Upon sensing movement, a button push, hand proximity or other indication that mouse 100 is needed by a user, mouse 100 returns to Active state 202. If the connection with computer 2 has been terminated, it must be recreated prior to (or as part of) a return to Active state 202.

**[0022]** FIG. 5 shows a second power management algorithm 220. Active state 222 is similar to Active state 202 of algorithm 200 (FIG. 4). The imaging components (LED 110 and imaging array 108) and RF circuitry 120 are activated at rapid rates. After 1 second of no activity, mouse 100 transitions to Idle state 224. Similar to Idle state 204 of algorithm 200, imaging and RF transmission rates are reduced. Unlike algorithm 200, however, mouse 100 remains in Idle state 224 for less time before transitioning to Extended Idle state 226. In one embodiment, mouse 100 transitions back to Active state 222 if activity is detected within 1 minute in Idle state 224. If no activity is detected after 1 minute, mouse 100 transitions to Extended Idle state 226. Similar to Extended Idle state 206 of algorithm 200, controller 114 deacti-

vates RF circuitry 120 and no longer transmits to (or listens for transmissions from) computer 2 while in Extended Idle state 226. Upon detection of user activity, mouse 100 returns to Active state 222. Upon entering Extended Idle state 226, mouse 100 will have terminated the connection with dongle 8, and the connection must be re-established prior to (or as a part of) return to Active state 222.

**[0023]** As can be appreciated from the preceding description, algorithm 220 allows mouse 100 to more quickly deactivate RF circuitry 120, thereby saving power. However, this comes at a cost of more frequently re-establishing the connection with computer 2. If the time to reestablish this connection is too long, the user will perceive a delay between the time he or she attempts to resume input with mouse 100 and the time that the input is acknowledged by computer 2. In some cases this may only be an annoyance, while in other cases it may actually result in data loss (e.g., a mouse click might not be detected by computer 2, and the user might not realize this nondetection).

**[0024]** Accordingly, and as further illustrated with FIG. 6, mouse 100 chooses between power management algorithms 200 and 220 based on one or more parameters of a connection created between mouse 100 and computer 2. When a connection between mouse 100 and computer 2 is initially established, a series of messages are transmitted between mouse 100 and dongle 8. The content, format, sequence and other details of these messages are described in the previously-referenced BLUETOOTH documents, and thus not further described herein. As part of these messages, various Link Manager (LM) protocol data units (PDU) 300 are transmitted from dongle 8 to mouse 100. Contained within one or more PDUs 300 are data identifying features supported by dongle 8 and/or computer 2. Many such features are specific to version 1.1 or to version 1.2 of the BLUETOOTH standard, or to a proprietary feature that may be supported by dongle 8 and/or computer 2. For example, Adaptive Frequency Hopping (AFH) is one feature supported by BLUETOOTH version 1.2 but not by version 1.1. If dongle 8 is a BLUETOOTH version 1.2 device, it will enable AFH by issuing (within a PDU 300) a LMP\_set\_AFH command. If mouse 100 receives such a command, controller 114 thereby determines that computer 2 is communicating via the BLUETOOTH version 1.2 standard.

**[0025]** In at least one embodiment, the default reconnection times for BLUETOOTH version 1.2 is within acceptable limits of latency of mouse 100. For example, mouse 100 may be designed for (or configured for) use by an individual more willing to accept some degree of latency in return for longer battery life. In this embodiment, controller 114 is programmed to implement power management algorithm 220 upon detection of a parameter indicative of a BLUETOOTH v1.2 connection with a computer, and to otherwise implement power management algorithm 200. In another embodiment, mouse

100 is designed (or configured) for a user who is unwilling to accept a degree of latency associated with the default reconnection time of BLUETOOTH v1.2. In this embodiment, however, mouse 100 is further equipped with hardware and/or firmware that permit mouse 100 to reconnect more quickly than the default BLUETOOTH v1.2 connection time, so long as the connection is established with another device that is also equipped with the required hardware and/or firmware. If a mouse 100 in this embodiment receives a PDU 300 from dongle 8 indicating that dongle 8 has the required hardware and/or firmware, controller 114 implements power management algorithm 220. Otherwise, mouse 100 implements power management algorithm 200.

[0026] As previously indicated, the invention is not limited to computer mice. FIG. 7 shows a computer keyboard 6' according to another embodiment of the invention. FIG. 8 is a block diagram for internal circuitry for keyboard 6' according to one embodiment of the invention. Operation of keyboard 6' is controlled by microprocessor 152. Microprocessor 152 scans for one or more presses (or releases) of a key by scanning key conductor matrix 154, and upon detecting a key press (or release), causes the appropriate make or break code (s) to be transmitted by RF circuitry 156. Microprocessor 152 also communicates with memory 160, upon which power management algorithms 200 and 220 are stored. Microprocessor 152 and other components of keyboard 6' are powered by battery 158. In one embodiment, microprocessor 152, upon receiving a PDU 300' (FIG. 7) indicating computer 2 communicates via BLUETOOTH v1.2, implements power management algorithm 220. Otherwise, microprocessor implements power management algorithm 200. In another embodiment, keyboard 6' is further equipped with hardware and/or firmware that permit keyboard 6' to reconnect more quickly than the default BLUETOOTH v1.2 connection time, so long as the connection is established with another device that is also equipped with the required hardware and/or firmware. If a keyboard 6' of this embodiment receives a PDU 300' from dongle 8 indicating that dongle 8 has the required hardware and/or firmware, microprocessor 152 implements power management algorithm 220. Otherwise, keyboard 6' implements power management algorithm 200.

[0027] FIG. 9 is a state diagram for a controller (such as controller 114 of FIG. 3 or microprocessor 152 of FIG. 8) of an input device configured to operate in accordance with at least one embodiment of the invention. FIG. 9 combines FIGS. 4 and 5 in certain respects. In state 301, the controller is establishing (or re-establishing) a connection with another BLUETOOTH device. When initially establishing the connection, the controller receives one or more PDUs providing parameters for the connection. In state 302, the controller determines, based on parameters identified in state 301, which power management algorithm to implement. If the parameters of the connection correspond to a connection type

that supports sufficiently fast re-establishment of a connection, a first (more power-conserving) algorithm is implemented. In particular, the controller places the input device in Active state 304, which is similar to active state 222 (FIG. 5). After 1 second of no activity, the controller transitions the input device to Idle state 306, which is similar to Idle state 224 of FIG. 5. The input device transitions back to Active state 304 if activity is detected within 1 minute in Idle state 306. If no activity is detected after 1 minute, the input device transitions to Extended Idle state 308. Similar to Extended Idle state 226 of algorithm 220, the controller deactivates RF circuitry and no longer transmits to (or listens for transmissions from) a remote device while in Extended Idle state 308. Upon detection of user activity, the controller transitions the input device to state 301 and establishes or re-establishes a connection. If the connection is a re-established connection with the same remote device, this is determined in state 301, the various connection parameters (previously received when initially establishing the connection) are not retransmitted, and the input device transitions directly from state 301 to state 304. If the connection is with another remote device, the connection parameters for the new remote device are received, and a determination is made at state 302 as to whether the newly connected remote device supports a sufficiently fast re-establishment of a connection. If so, the input device again transitions to state 304.

[0028] If it is determined in state 302 after initially establishing a connection with a remote device that the parameters of the just-established connection do not correspond to a connection type supporting sufficiently fast re-establishment of a connection, a second (less power-conserving) algorithm is implemented. In particular, the controller places the input device in Active state 310, which is similar to active state 202 (FIG. 4). After 1 minute of no activity, the controller transitions the input device to Idle state 312, which is similar to Idle state 204 of FIG. 4. The input device transitions back to Active state 310 if activity is detected within 10 minutes in Idle state 312. If no activity is detected after 10 minutes, the input device transitions to Extended Idle state 314. Similar to Extended Idle state 206 of algorithm 200, the controller deactivates RF circuitry and no longer transmits to (or listens for transmissions from) a remote device while in Extended Idle state 314. Upon detection of user activity, the controller transitions the input device to state 301 and establishes or re-establishes a connection. If the connection is a re-established connection with the same remote device, the input device returns to Active state 310 directly from state 301.

[0029] FIG. 10 is a state diagram for a computer input device according to another embodiment of the invention. Similar to state 301 of FIG. 9, a controller of a device according to FIG. 10 establishes (or re-establishes) a connection with another BLUETOOTH device in state 401. As part of establishing the connection, the controller receives one or more PDUs providing parameters for

the connection. In state 402, and similar to state 302 of FIG. 9, the controller determines, based on parameters identified in state 401, which power management algorithm to implement. In the embodiment of FIG. 10, however, the controller selects from three or more power management algorithms 404, 406, 408, etc.

**[0030]** Although specific examples of carrying out the invention have been described, those skilled in the art will appreciate that there are numerous variations and permutations of the above described systems and techniques that fall within the spirit and scope of the invention as set forth in the appended claims. These and other modifications are within the scope of the invention as defined by the attached claims.

### Claims

1. A device comprising:

a battery power source;  
 a radio transceiver powered by the battery and having components for transmission and receipt of data;  
 a memory having instructions stored thereon;  
 and  
 a controller coupled to the transceiver and to the memory and configured execute the instructions so as to:

create, via the transceiver, wireless connections with remote devices in any of a plurality of connection configurations,  
 detect the presence, in a wireless transmission from a remote device, of one or more parameters identifying one of the plurality of configurations, and  
 implement, based on the configuration identified, one of a plurality of power management algorithms.

2. The device of claim 1, wherein the controller is configured to detect the presence of one or more parameters by determining if a wireless connection with the remote device has at least one parameter corresponding to an acceptably fast re-connection procedure.

3. The device of claim 2, wherein the controller is configured to:

implement, upon determining the presence of the at least one parameter, a power management algorithm in which the transceiver is deactivated after a first period of device inactivity, and  
 implement, upon determining the absence of the at least one parameter, a power manage-

ment algorithm in which the transceiver is deactivated after a second period of device inactivity, the second period being longer than the first period.

4. The device of claim 3, wherein the controller is configured such that the device is inactive if the device is not being used to generate or transmit data based on input from a human user of the device.

5. The device of claim 1, wherein the controller is further configured detect the presence of one or more parameters at the time of establishing a wireless connection with a remote device.

6. The device of claim 1, wherein the plurality of power management algorithms comprises three or more power management algorithms.

7. The device of claim 1, wherein the device is a computer input device.

8. The device of claim 7, wherein the device is a computer mouse.

9. The device of claim 7, wherein the device is a computer keyboard.

10. A method for automatically selecting a power management algorithm in a battery-powered wireless device capable of creating wireless connections with a remote device in any of a plurality of connection configurations, comprising:

establishing a wireless connection with a remote device;  
 determining wireless communication features supported by the remote device;  
 implementing a first power management algorithm if the remote device supports a first communication feature; and  
 implementing a second power management algorithm if the remote device does not support the first feature.

11. The method of claim 10, wherein the first communication feature comprises support for an acceptably fast re-connection procedure.

12. The method of claim 11, wherein:

the first power management algorithm comprises deactivating a transceiver after a first period of wireless device inactivity, and  
 the second power management algorithm comprises deactivating the transceiver after a second period of wireless device inactivity, the second period being longer than the first period.

13. The method of claim 12, wherein the wireless device is inactive if the wireless device is not being used to generate or transmit data based on input from a human user. 5
14. The method of claim 10, further comprising:  
 implementing a third power management algorithm if the remote device does not support the first feature but supports a second feature. 10
15. The method of claim 10, wherein said determining wireless communication features comprises determining wireless communication features at the time of establishing a wireless connection with a remote device. 15
16. A machine-readable medium having stored thereon data representing sequences of instructions which, when executed by a processor, cause the processor to perform steps comprising: 20  
 establishing, from a battery-powered wireless device capable of creating wireless connections with a remote device in any of a plurality of connection configurations, a wireless connection with a remote device; 25  
 determining wireless communication features supported by the remote device; 30  
 implementing a first power management algorithm if the remote device supports a first communication feature; and  
 implementing a second power management algorithm if the remote device does not support the first feature. 35
17. The machine-readable medium of claim 16, wherein the first communication feature comprises support for an acceptably fast re-connection procedure. 40
18. The machine-readable medium of claim 17, wherein:  
 the first power management algorithm comprises deactivating a transceiver after a first period of wireless device inactivity, and 45  
 the second power management algorithm comprises deactivating the transceiver after a second period of wireless device inactivity, the second period being longer than the first period. 50
19. The machine-readable medium of claim 18, wherein the wireless device is inactive if the wireless device is not being used to generate or transmit data based on input from a human user. 55
20. The machine-readable medium of claim 16, comprising further sequences of instructions which  
 cause the processor to perform steps comprising:  
 implementing a third power management algorithm if the remote device does not support the first feature but supports a second feature. 5
21. The machine-readable medium of claim 16, wherein said determining wireless communication features comprises determining wireless communication features at the time of establishing a wireless connection with a remote device.

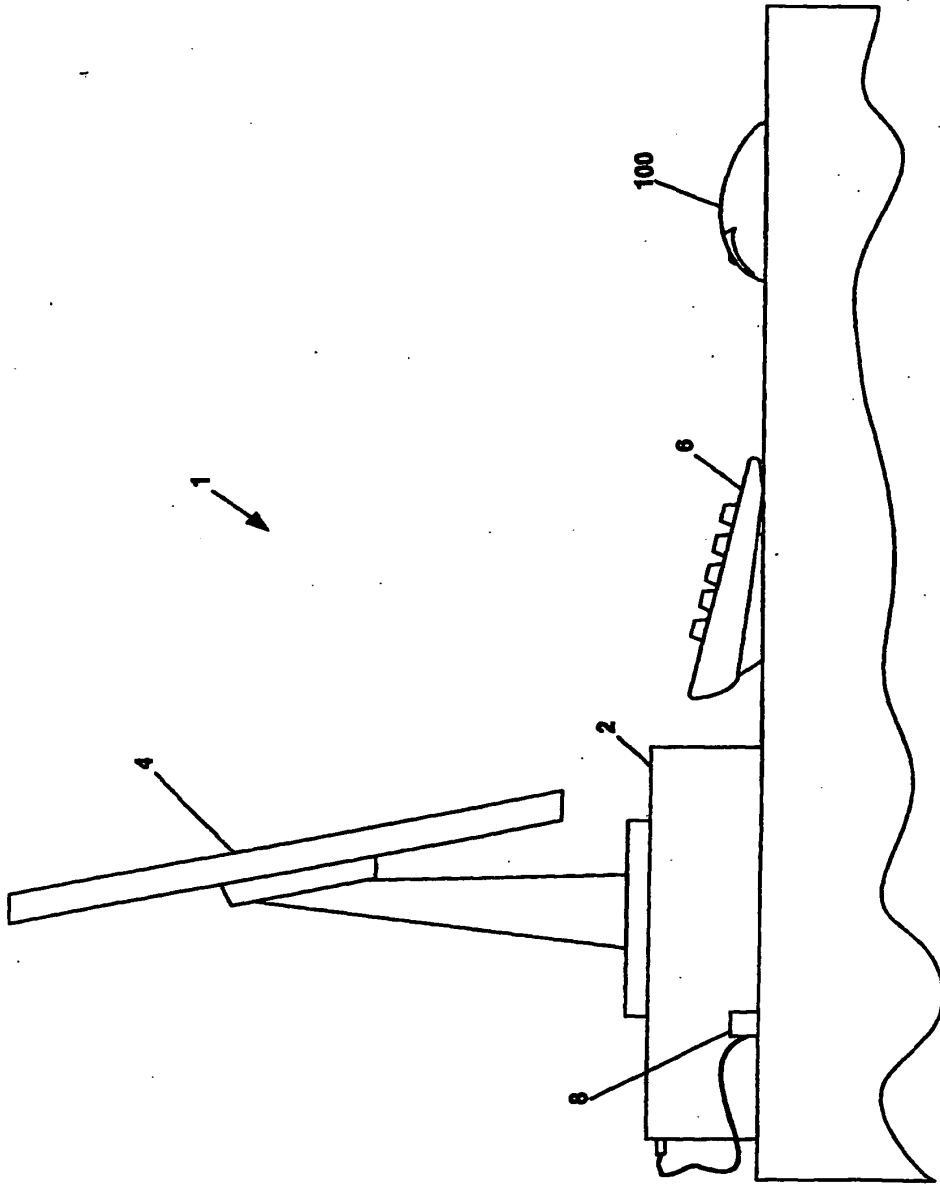
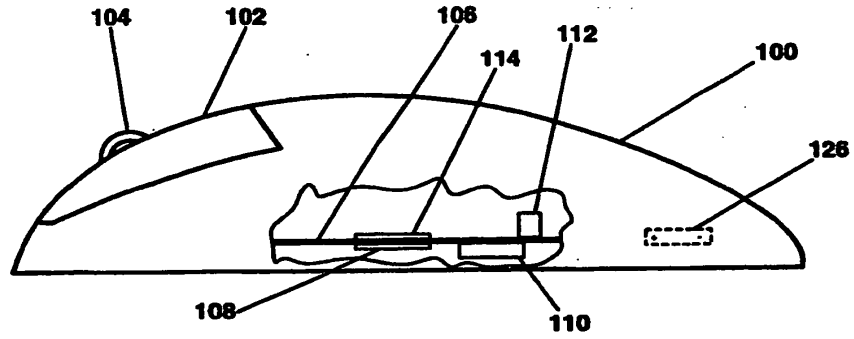
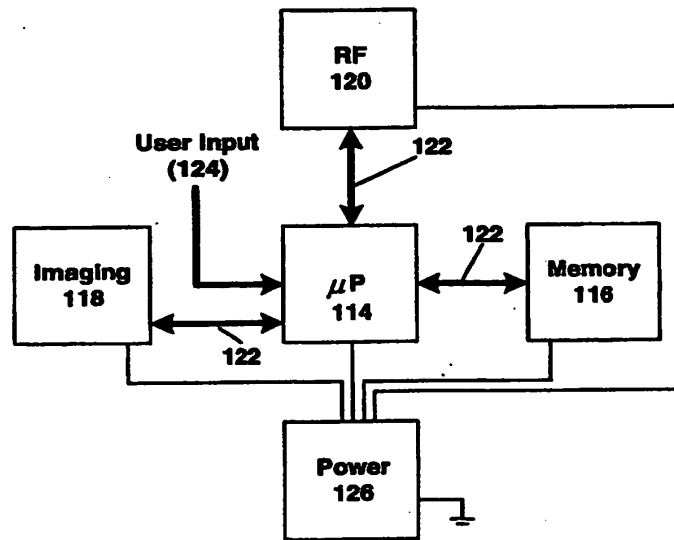

FIG. 1



**FIG. 2**



**FIG. 3**



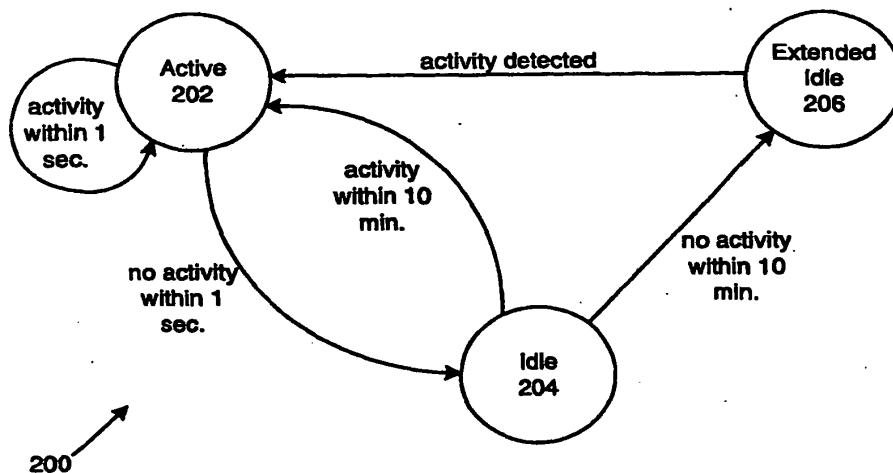

FIG. 4

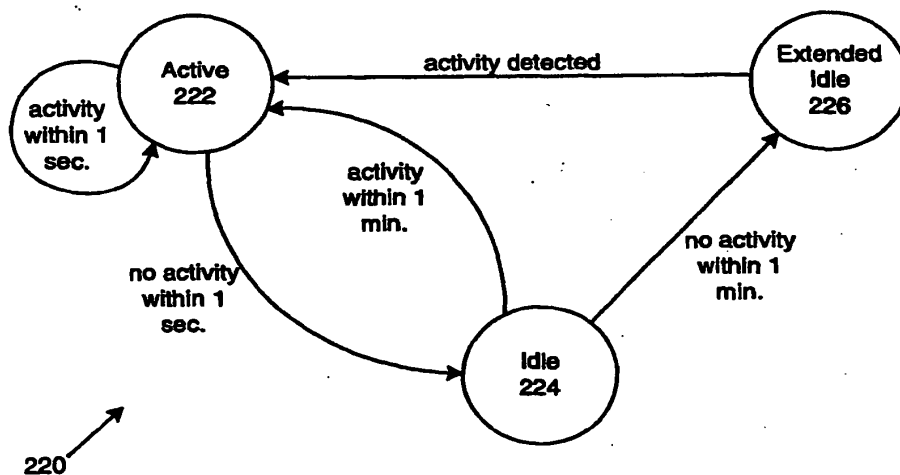

FIG. 5

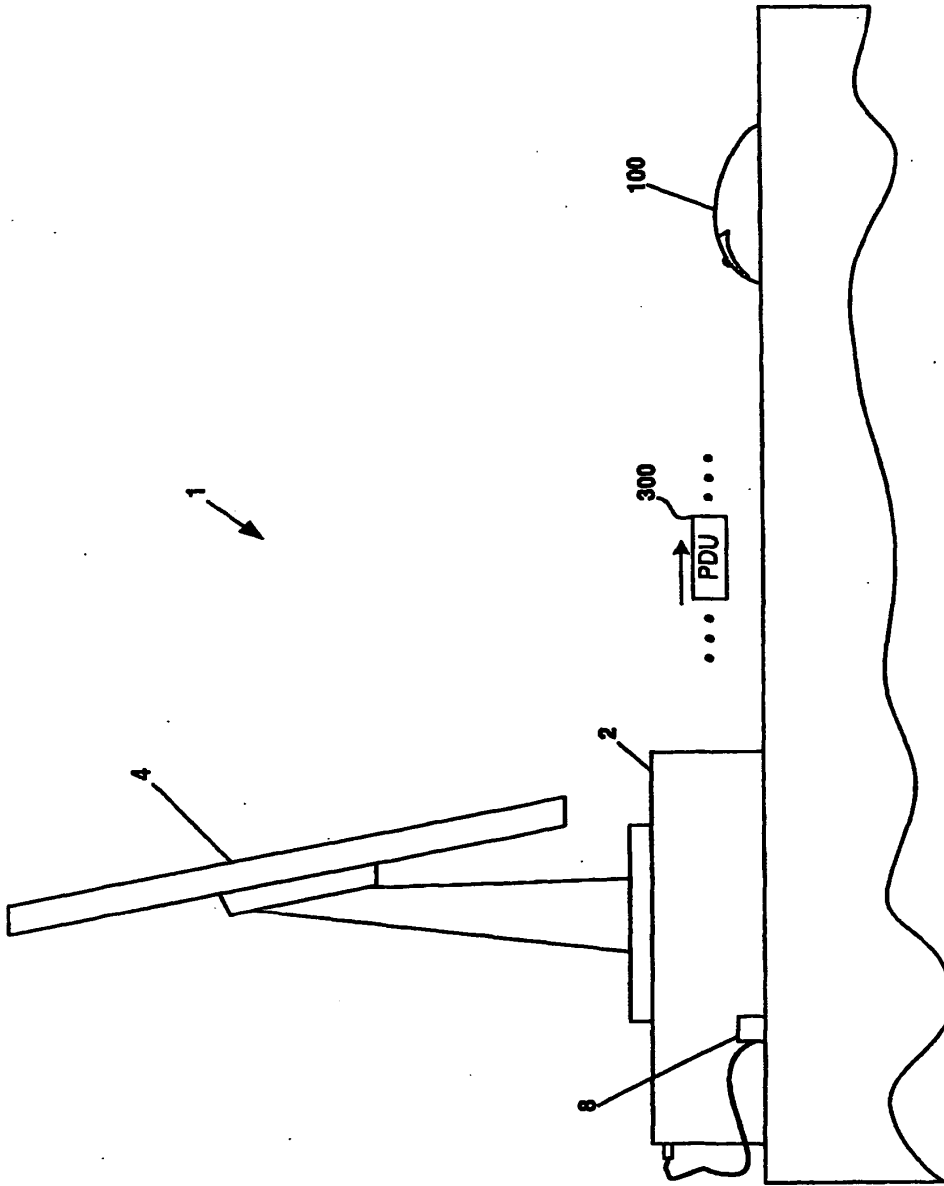

FIG. 6

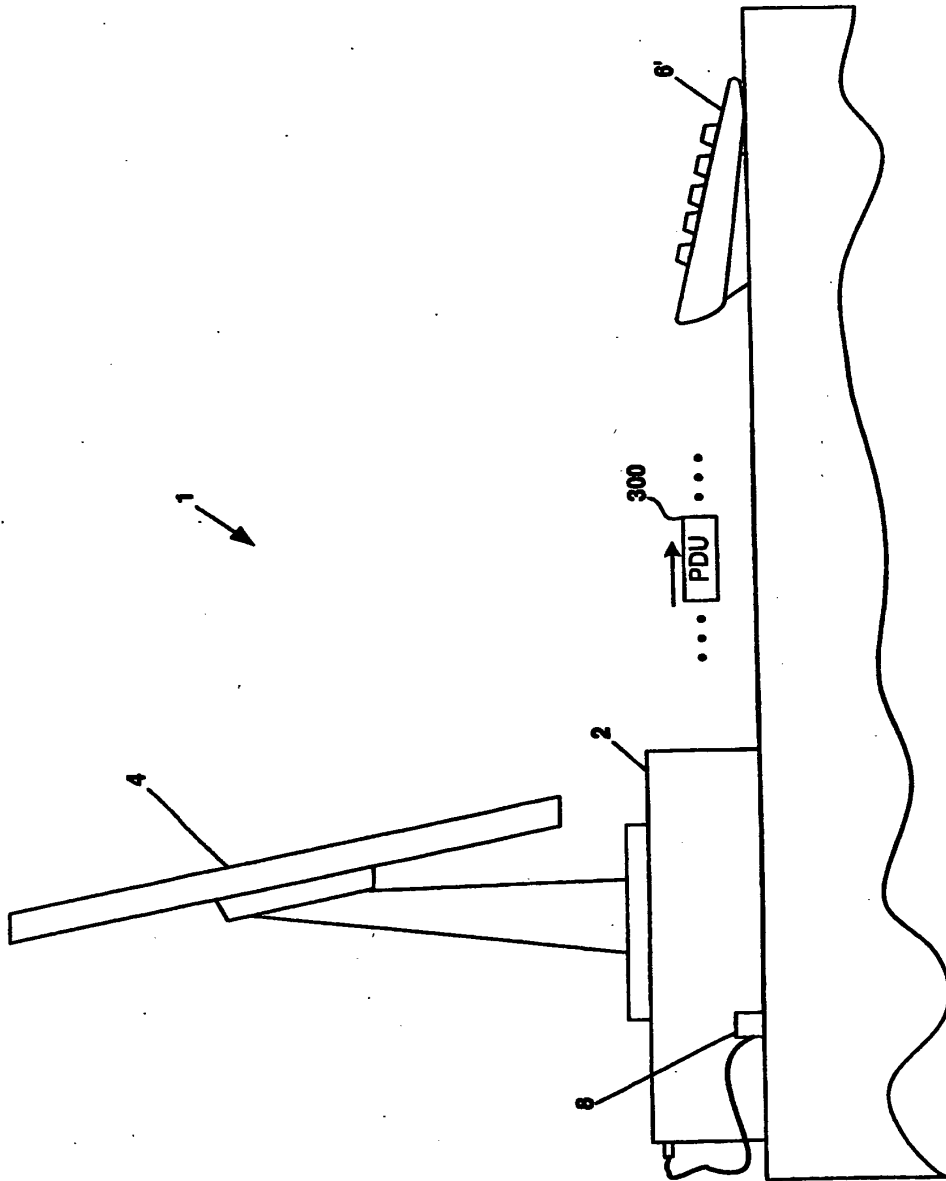
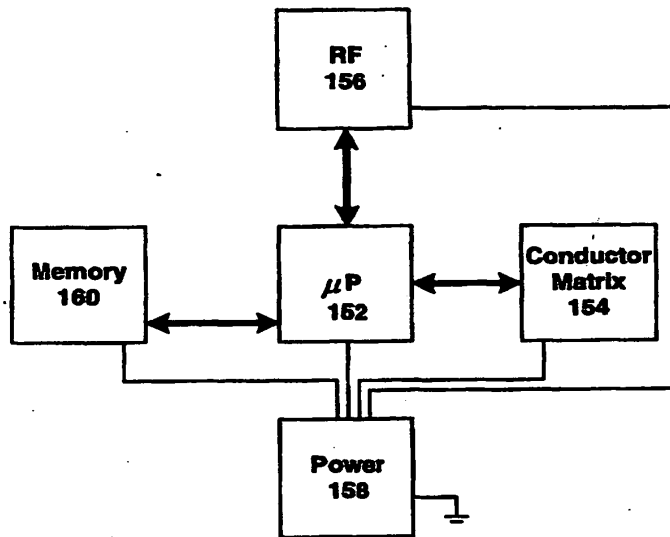

FIG. 7



**FIG. 8**

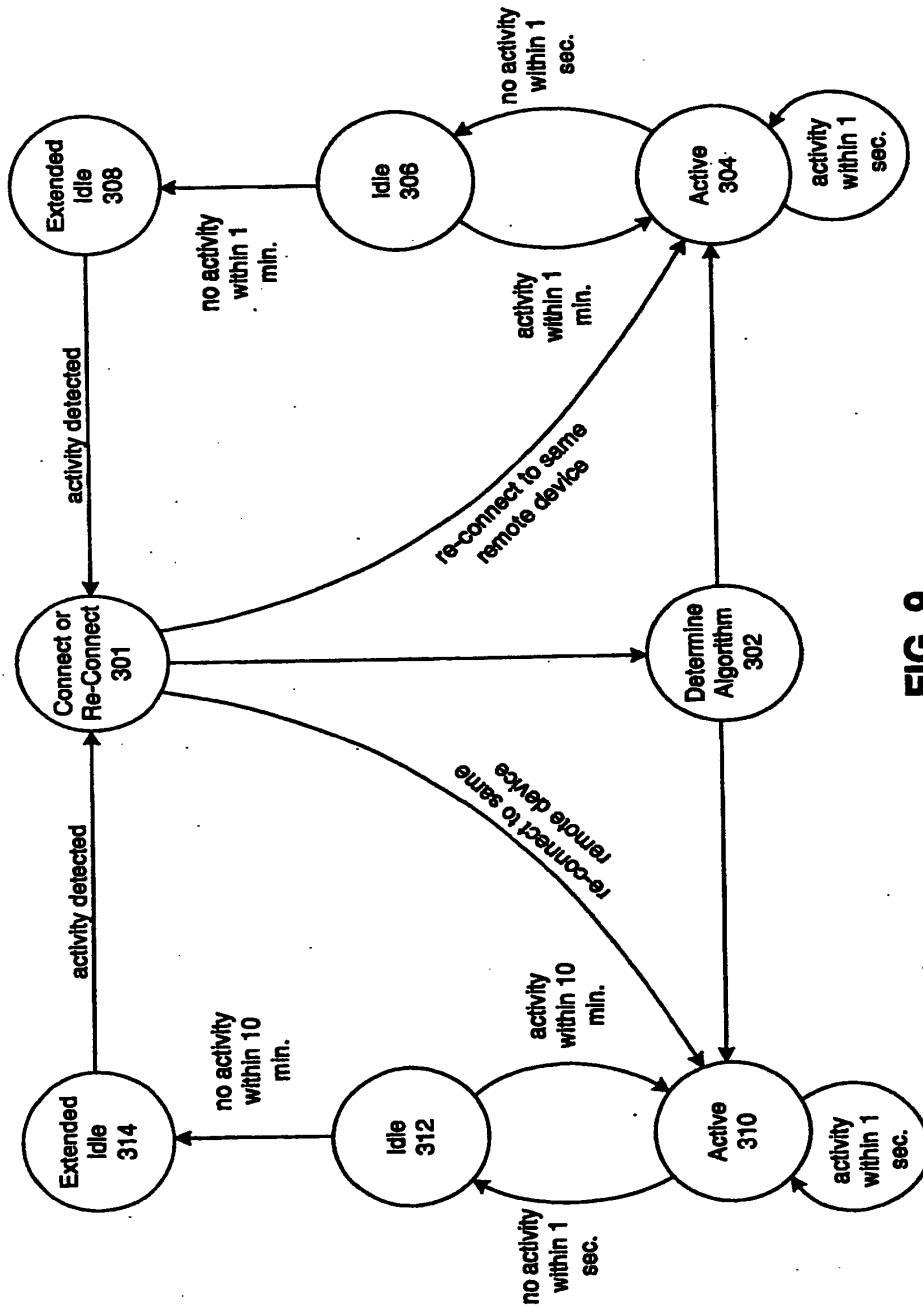

FIG. 9

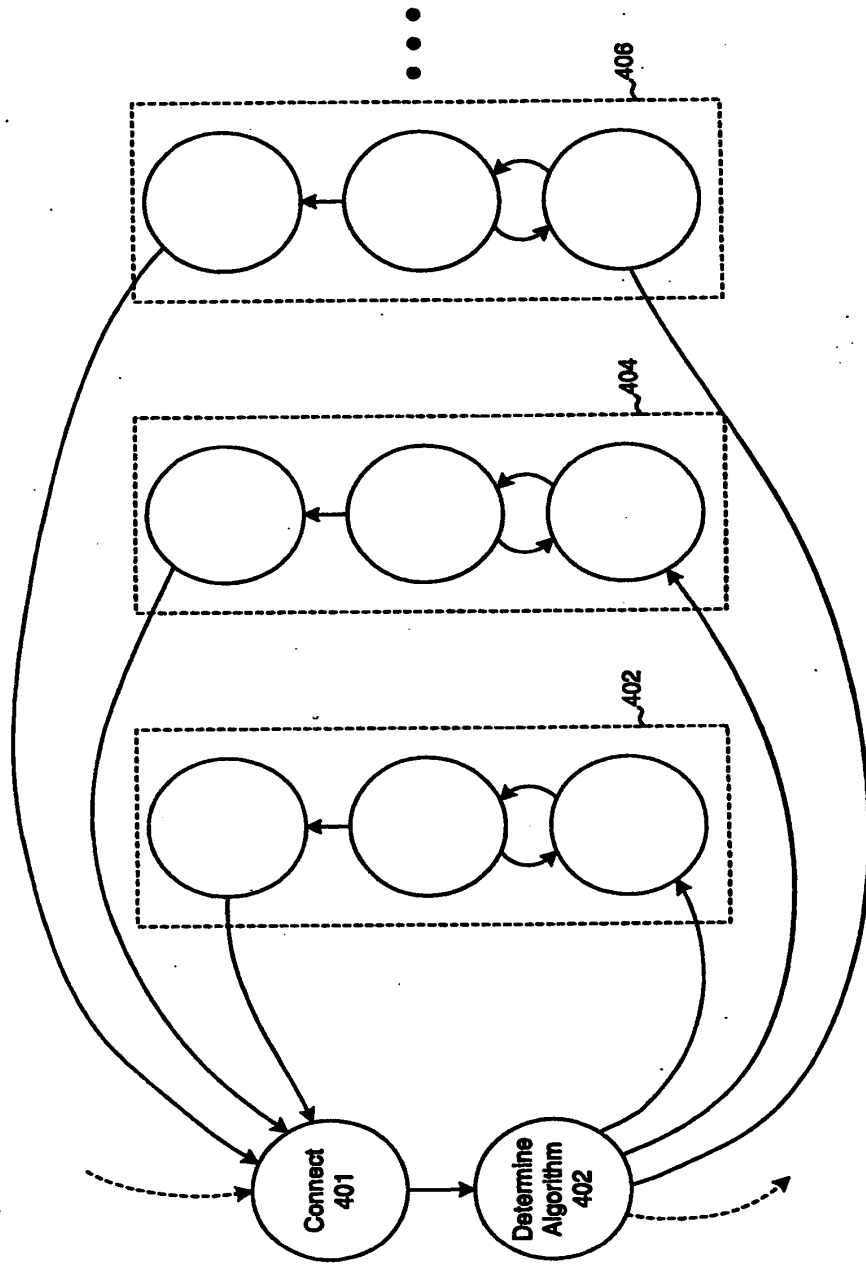

FIG. 10



*DAK*

**DAVID A. KIEWIT**  
Registered Patent Agent

5901 3<sup>rd</sup> St., South.  
St. Petersburg FL 33705-5305

(727) 866-0669 voice/fax  
e-mail: dak@patent-faq.com

---

November 20, 2008

Commissioner for Patents  
P. O. Box 1450  
Alexandria VA 22313

Re: Application 12/179769  
My ref.: QAP

Sir,

The enclosed Information Disclosure Statement is timely filed with references cited in examination of an equivalent UK application mailed within the past month.

This Information Disclosure was mailed to Mail Stop Amendment, Commissioner for Patents, P. O. Box 1450, Alexandria VA 22313-1450 by first class mail, with sufficient postage, on November 21, 2008.

Respectfully submitted

David A. Kiewit

*Reg 34640*



UNITED STATES PATENT AND TRADEMARK OFFICE

UNITED STATES DEPARTMENT OF COMMERCE
United States Patent and Trademark Office
Address: COMMISSIONER FOR PATENTS
P.O. Box 1450
Alexandria, Virginia 22313-1450
www.uspto.gov

Table with 4 columns: APPLICATION NUMBER (12/179,769), FILING OR 371(C) DATE (07/25/2008), FIRST NAMED APPLICANT (Harald Philipp), ATTY. DOCKET NO./TITLE (QAP)

CONFIRMATION NO. 8745

PUBLICATION NOTICE

20191
DAVID KIEWIT
5901 THIRD ST SOUTH
ST PETERSBURG, FL 33705



Title: Proximity Sensor

Publication No. US-2009-0027068-A1

Publication Date: 01/29/2009

NOTICE OF PUBLICATION OF APPLICATION

The above-identified application will be electronically published as a patent application publication pursuant to 37 CFR 1.211, et seq. The patent application publication number and publication date are set forth above.

The publication may be accessed through the USPTO's publicly available Searchable Databases via the Internet at www.uspto.gov. The direct link to access the publication is currently http://www.uspto.gov/patft/.

The publication process established by the Office does not provide for mailing a copy of the publication to applicant. A copy of the publication may be obtained from the Office upon payment of the appropriate fee set forth in 37 CFR 1.19(a)(1). Orders for copies of patent application publications are handled by the USPTO's Office of Public Records. The Office of Public Records can be reached by telephone at (703) 308-9726 or (800) 972-6382, by facsimile at (703) 305-8759, by mail addressed to the United States Patent and Trademark Office, Office of Public Records, Alexandria, VA 22313-1450 or via the Internet.

In addition, information on the status of the application, including the mailing date of Office actions and the dates of receipt of correspondence filed in the Office, may also be accessed via the Internet through the Patent Electronic Business Center at www.uspto.gov using the public side of the Patent Application Information and Retrieval (PAIR) system. The direct link to access this status information is currently http://pair.uspto.gov/. Prior to publication, such status information is confidential and may only be obtained by applicant using the private side of PAIR.

Further assistance in electronically accessing the publication, or about PAIR, is available by calling the Patent Electronic Business Center at 1-866-217-9197.

Office of Data Management, Application Assistance Unit (571) 272-4000, or (571) 272-4200, or 1-888-786-0101



RECEIVED  
CENTRAL FAX CENTER  
APR 30 2009

IN THE UNITED STATES PATENT AND TRADEMARK OFFICE

REVOCATION AND POWER OF ATTORNEY  
CERTIFICATE UNDER 37 CFR § 3.73(b)  
&  
CHANGE OF CORRESPONDENCE ADDRESS

Commissioner for Patents  
P.O. Box 1450  
Alexandria, VA 22313-1450

In accordance with 37 C.F.R. Section 1.36, M.P.E.P. Section 402.05 and 402.07, please revoke any existing Powers of Attorney, if any, for the below listed applications, and appoint the following attorneys and/or patent agents to prosecute these applications and to transact all business in the Patent and Trademark Office in connection therewith:

Customer Number: 76287

<u>Appl. Serial</u> <u>No.:</u> <u>&amp;</u> <u>Docket No.</u>	<u>Filing Date</u>	<u>Applicant</u>	<u>Reel/Frames</u>	<u>Recordation</u> <u>Date</u>
10/916,744 3050.004US1	Aug 12, 2004	Philipp	021791/0040	11/05/2008
10/916,759 3050.005US1	Aug 12, 2004	Philipp	021791/0040	11/05/2008
11/422,799 3050.008US1	June 7, 2005	Philipp	021791/0040	11/05/2008
11/333,489 3050.009US1	Jan 17, 2006	Philipp	021791/0040	11/05/2008
11/536,583 3050.012US1	Sep 28, 2006	Philipp	021791/0040	11/05/2008
11/163,944 3050.014US1	Nov 4, 2005	Philipp	021791/0040	11/05/2008
11/532,560 3050.016US1	Sept. 18, 2006	Philipp et al	021787/0321	11/05/2008
12/061,483 3050.017US1	Apr 2, 2008	Philipp et al	021834/0001	11/14/2008

- 1 -

<u>Appl. Serial No.:</u> <u>&amp;</u> <u>Docket No.</u>	<u>Filing Date</u>	<u>Applicant</u>	<u>Reel/Frames</u>	<u>Recordation Date</u>
11/734,813 3050.020US1	Apr 13, 2007	Philipp	021791/0040	11/05/2008
11/279,402 3050.022US1	Apr 12, 2006	Philipp	021791/0040	11/05/2008
11/750,430 3050.023US1	May 18, 2007	Philipp	021791/0040	11/05/2008
11/765,393 3050.024US1	Jun 19, 2007	Philipp	021791/0040	11/05/2008
11/743,349 3050.026US1	May 2, 2007	Philipp	021791/0040	11/05/2008
11/868,563 3050.028US1	Oct 8, 2007	Philipp	021791/0040	11/05/2008
11/868,566 3050.029US1	Oct 8, 2007	Philipp	021791/0040	11/05/2008
* 12/179,769 3050.030US1	Jul 25, 2008	Philipp et al	021758/0843	10/29/2008
11/750,588 3050.031US1	May 18, 2007	Hristov	021834/0870	11/14/2008

**CERTIFICATE UNDER 37 CFR § 3.73(b)**

Atmel Corporation hereby certifies that it is the assignee of the entire right, title and interest in the patent applications identified above by virtue of:

assignments from the inventor(s) of the patent applications identified above: and  
assignment from ORG Limited to Atmel Corporation filed on even-date herewith  
(attached). To the best of my knowledge and belief, titles are in Atmel Corporation, the assignee.

- 2 -

Pursuant to 37 C.F.R. § 3.73(b) I hereby declare that I am empowered to sign this certificate on behalf of Atmel Corporation, the assignee.

I hereby declare that all statements made herein of my own knowledge are true, and that all statements made on information and belief are believed to be true.

Please direct all correspondence in this case to:

Schwegman, Lundberg & Woessner, P.A.  
Customer No. 76287

Date 4/29/09

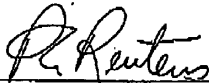
By   
Name: Patrick Reutens  
Title: Chief Legal Officer

RECEIVED  
CENTRAL FAX CENTER  
APR 30 2009

SCHWEGMAN ■ LUNDBERG ■ WOESSNER  
PATENT, TRADEMARK & COPYRIGHT ATTORNEYS  
P.O. Box 2938  
Minneapolis, MN 55402  
Telephone (612) 373-6900 Facsimile (612) 339-3061

April 30, 2009

TO: Commissioner for Patents  
Attn: Diego Gutierrez  
Patent Examining Corps  
Facsimile Center  
P.O. Box 1450  
Alexandria, VA 22313-1450

FROM: Bradley A. Forrest

OUR REF: 3050.030US1

**FAX NUMBER (571) 273-8300**

\* Please deliver to Art Unit 2831. \*

Document(s) Transmitted: Revocation and Power of Attorney & Change of Correspondence  
Address with as-filed Assignment Recordation Sheet with appendix ( 8 pgs.).

Total pages of this transmission, including cover letter: 9 pgs.

If you do NOT receive all of the pages described above, please telephone us at 612-373-6900 or fax us at 612-339-3061.

In re. Patent Application of: Harald Philipp et al.

Examiner: Diego Gutierrez

Serial No.: 12/179,769

Group Art Unit: 2831

Filed: July 25, 2008

Docket No.: 3050.030US1

Title: Proximity Sensor

By: Bradley A. Forrest  
Name: Bradley A. Forrest  
Reg. No.: 30,837

I hereby certify that this paper is being transmitted by facsimile to the U.S. Patent and Trademark Office on the date shown below.

Michele Quaranto  
Michele Quaranto

4-30-09  
Date of Transmission



UNITED STATES PATENT AND TRADEMARK OFFICE

UNITED STATES DEPARTMENT OF COMMERCE  
United States Patent and Trademark Office  
Address: COMMISSIONER FOR PATENTS  
P.O. Box 1450  
Alexandria, Virginia 22313-1450  
www.uspto.gov

APPLICATION NUMBER	FILING OR 371(C) DATE	FIRST NAMED APPLICANT	ATTY. DOCKET NO./TITLE
12/179,769	07/25/2008	Harald Philipp	3050.030US1

**CONFIRMATION NO. 8745**

**POA ACCEPTANCE LETTER**

76287  
SCHWEGMAN, LUNDBERG & WOESSNER / ATMEL  
P.O. BOX 2938  
MINNEAPOLIS, MN 55402



Date Mailed: 05/14/2009

**NOTICE OF ACCEPTANCE OF POWER OF ATTORNEY**

This is in response to the Power of Attorney filed 04/30/2009.

The Power of Attorney in this application is accepted. Correspondence in this application will be mailed to the above address as provided by 37 CFR 1.33.

/mtekle michael/

Office of Data Management, Application Assistance Unit (571) 272-4000, or (571) 272-4200, or 1-888-786-0101

Under the Paperwork Reduction Act of 1995, no persons are required to respond to a collection of information unless it contains a valid OMB control number.

Substitute for form 1449A/PTO <b>INFORMATION DISCLOSURE                  STATEMENT BY APPLICANT</b> (Use as many sheets as necessary)	<i>Complete if Known</i>	
	<b>Application Number</b>	12/179,769
	<b>Filing Date</b>	July 25, 2008
	<b>First Named Inventor</b>	Harald Philipp
	<b>Group Art Unit</b>	Unknown
	<b>Examiner Name</b>	Diego Gutierrez
Sheet 1 of 1	Attorney Docket No: 3050.030US1	

US PATENT DOCUMENTS				
Examiner Initial *	USP Document Number	Publication Date	Name of Patentee or Applicant of cited Document	Filing Date If Appropriate
	US-20090027068A1	01/29/2009	Philipp, et al.	07/25/2008

FOREIGN PATENT DOCUMENTS				
Examiner Initials*	Foreign Document No	Publication Date	Name of Patentee or Applicant of cited Document	T <sup>1</sup>
	EP-1536314A2	06/01/2005	Albulet, M.	
	GB-2431725A1	05/02/2007	Harald, P.	

OTHER DOCUMENTS – NON PATENT LITERATURE DOCUMENTS		
Examiner Initials*	Include name of the author (in CAPITAL LETTERS), title of the article (when appropriate), title of the item (book, magazine, journal, serial, symposium, catalog, etc.), date, page(s), volume-issue number(s), publisher, city and/or country where published.	T <sup>1</sup>

EXAMINER

DATE CONSIDERED

\* EXAMINER: Initial if reference considered, whether or not citation is in conformance with MPEP 609. Draw line through citation if not in conformance and not considered. Include copy of this form with next communication to applicant. 1 Applicant is to place a check mark here if English language Translation is attached



(12) **EUROPEAN PATENT APPLICATION**

(43) Date of publication:  
**01.06.2005 Bulletin 2005/22**

(51) Int Cl.7: **G06F 1/32**

(21) Application number: **04026594.4**

(22) Date of filing: **09.11.2004**

(84) Designated Contracting States:  
**AT BE BG CH CY CZ DE DK EE ES FI FR GB GR HU IE IS IT LI LU MC NL PL PT RO SE SI SK TR**  
 Designated Extension States:  
**AL HR LT LV MK YU**

(72) Inventor: **Albulet, Mihai**  
**Redmond Washington 98052 (US)**

(74) Representative: **Grünecker, Kinkeldey, Stockmair & Schwanhäusser Anwaltssozietät Maximilianstrasse 58 80538 München (DE)**

(30) Priority: **25.11.2003 US 720116**

(71) Applicant: **MICROSOFT CORPORATION**  
**Redmond, WA 98052 (US)**

(54) **Modifying a power management algorithm based on wireless communication parameters**

(57) A wireless device determines characteristics of a connection established (or being established) with a remote device and implements a power management algorithm based on those characteristics. The wireless device includes a battery power source, a radio transceiver powered by the battery, a memory and a controller. The controller is configured to create, via the trans-

ceiver, wireless connections with remote devices in any of a plurality of connection configurations. The controller detects the presence, in a wireless transmission from a remote device, of one or more parameters identifying one of the plurality of configurations. Based on the configuration identified, the controller implements one of a plurality of power management algorithms.

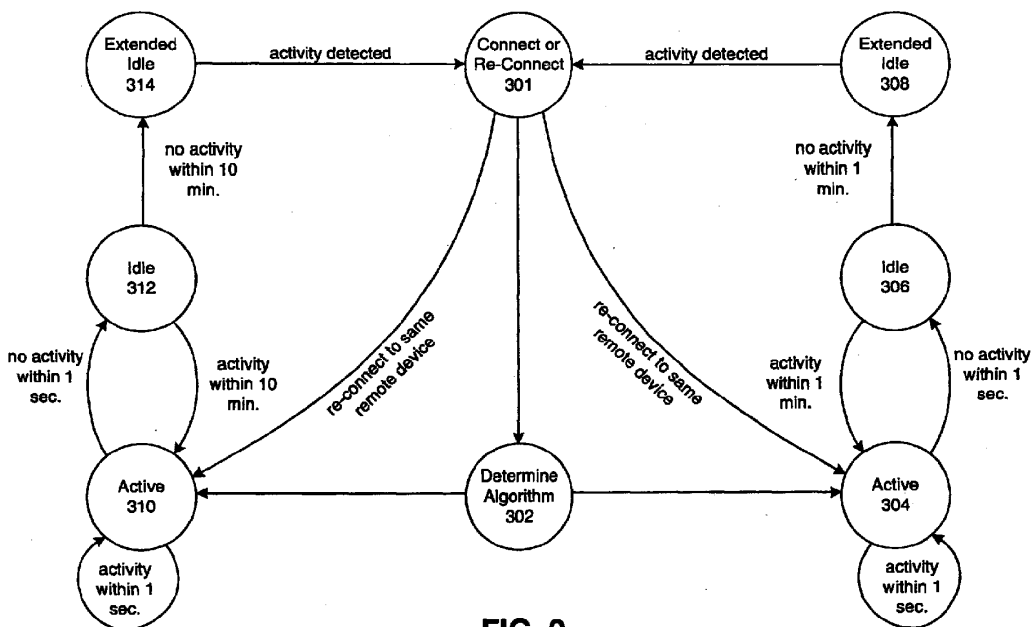

**FIG. 9**

EP 1 536 314 A2

**Description**

## FIELD OF THE INVENTION

**[0001]** This invention relates to power management in electronic devices that communicate via a wireless link.

## BACKGROUND OF THE INVENTION

**[0002]** Wireless communication between electronic devices over relatively short distances is a common and increasingly important feature of modern life. In some cases, for example, an electronic device or other appliance is controlled by another electronic device which must communicate instructions to the controlled device (and perhaps receive information from the controlled device). Examples include computer input devices (e.g., mice, trackballs, joysticks, game controllers) and remote control units (for, e.g., televisions or other appliances). In other cases, it is necessary for one electronic device to transmit more complex data to and/or receive such data from another device. Examples include computer keyboards, digital cameras and other devices able to transmit data to a computer or other device. Among other advantages, wirelessly transmitting data and/or control signals can dramatically increase user convenience and reduce clutter from multiple connecting cables.

**[0003]** Although there are several standards for wireless communication, BLUETOOTH is becoming the de facto standard for many applications. Developed by Bluetooth SIG, Inc., the BLUETOOTH wireless specification establishes protocols and standards for two-way wireless communication between electronic devices using relatively low power radio communication. BLUETOOTH is described by, e.g., "Specification of the Bluetooth System" (versions 1.1 and 1.2), "Human Interface Device (HID) Profile version 1.0" and various other documents available from Bluetooth SIG, Inc. at <http://www.bluetooth.com>. Among other things, BLUETOOTH provides for two-way radio links between multiple devices in a short-range radio network called a "piconet."

**[0004]** As one example of a BLUETOOTH piconet, a personal computer may be configured to receive input from one or more wireless input devices such as a wireless mouse and/or a wireless keyboard. In some cases, a user connects a device to the piconet by simply bringing the device within range of the computer's Bluetooth controller. In other cases, more steps may be required so that the device becomes bonded with the computer BLUETOOTH host so as to authenticate the device and establish secure communication between the devices. In either case, a series of inquiry, paging and other messages are exchanged between the input device and the computer to set up a connection over which user data (e.g., mouse movement or button press, keyboard key

down, etc.) is transmitted to the computer. In some cases, data from applications or other software executing on the computer is also transmitted over that connection to the input device. Details of the messages exchanged between devices to establish a connection are set forth in the above-referenced BLUETOOTH documents and are known in the art.

**[0005]** To maintain a connection, even when the input device has no user data to transmit, requires a periodic exchange between the input device and the computer. In effect, the input device periodically transmits a message saying "I am still here." The computer responds "OK, you are still on my list," and maintains the connection. Although the interval between user data and/or "I'm here" messages from the input device can be varied, it is generally on the order of tens of milliseconds. If the computer does not receive a message from the input device before expiration of a timeout period, the computer assumes the input device is turned off or absent, and breaks (or "de-lists") the connection with the device. In order for the input device to again communicate with the computer, another series of messages must be exchanged to re-establish the connection.

**[0006]** This can create a conflict with regard to design requirements for a wireless input device such as a computer mouse or keyboard. Because wireless devices are battery powered, it is desirable to reduce the device's power consumption as much as possible so as to prolong battery life. A significant amount of the device power is consumed by the radio transceiver that communicates with the controller. If other considerations are ignored, the period between transmissions should be reduced as much as possible during times when the device is idle, i.e., not actually communicating user data to the computer. If the interval between transmissions is too large, however, the connection to the computer is lost. Although the connection can be re-established, doing so is relatively time-consuming and increases the amount of time needed for user input (e.g., moving a mouse) to cause the appropriate response by the computer (e.g., moving a cursor).

**[0007]** This input-to-response delay, or latency, can be noticeable to a human if it is approximately 100 milliseconds or more. The acceptable amount of perceived latency varies under different conditions and with different users and usage styles. For computers and input devices operating under the earlier version (1.1) of the BLUETOOTH specification, the time to re-establish the connection can be approximately 1 second or more. Under version 1.2 of the BLUETOOTH specification, the reconnect time is reduced, and in some cases may be as little as approximately 250 milliseconds. This is a significant improvement, and may result in acceptable latency in some circumstances. Under other conditions, this may still result in excessive latency. However, the BLUETOOTH specification allows manufacturers to incorporate additional features into a BLUETOOTH-compliant device (whether a computer, an input device or



otherwise), so long as those additional features do not prevent that device from providing certain other features that are mandatory for BLUETOOTH compliance. Accordingly, manufacturers are able to develop BLUETOOTH-compliant chipsets providing a re-connect procedure that is faster than the "default" connection procedure of the BLUETOOTH specification.

**[0008]** Unfortunately, advantages of faster BLUETOOTH version 1.2 and proprietary re-connection procedures may not be achievable in many cases. For example, a computer mouse could be equipped with the hardware and firmware necessary to implement a proprietary fast re-connect procedure, but the mouse might be used with a computer that does not support the fast re-connect procedure. If used with a computer supporting the fast re-connect procedure, the mouse could implement a power-management algorithm that suspends radio communication with the computer for time periods that may cause the mouse-computer radio connection to be broken. Upon need for transmission of data to the computer (e.g., the user moves the mouse after a period of no mouse use), the connection can be re-established sufficiently fast to avoid (or minimize) any perceived latency. If, however, the mouse is used with a computer not supporting a fast re-connect procedure, that power management algorithm would likely result in unacceptable latency.

**[0009]** Various systems and methods are known for automatic detection of a protocol by which a device communicates with a computer. U.S. Patents 6,442,734 and 5,754,890, assigned to the assignee of the present invention, are two examples. However, neither these patents nor other known prior art describes optimizing (or otherwise modifying) a power management algorithm based on parameters of a communication link between devices, and in particular, based on parameters of a wireless communication connection.

#### SUMMARY OF THE INVENTION

**[0010]** Embodiments of the invention allow a wireless device to determine characteristics of a connection established (or being established) with a remote device, and to then implement a power management algorithm based on those characteristics. In one embodiment, a wireless device includes a battery power source, a radio transceiver powered by the battery, a memory and a controller. The controller is configured to create, via the transceiver, wireless connections with remote devices in any of a plurality of connection configurations. The controller detects the presence, in a wireless transmission from a remote device, of one or more parameters identifying one of the plurality of configurations. Based on the configuration identified, the controller implements one of a plurality of power management algorithms.

**[0011]** These and other features and advantages of the present invention will be readily apparent and fully understood from the following detailed description of

preferred embodiments, taken in connection with the appended drawings.

#### BRIEF DESCRIPTION OF THE DRAWINGS

##### **[0012]**

FIG. 1 is a view of a computing system environment implementing at least one embodiment of the invention.

FIG. 2 is a cutaway side view of the wireless mouse of FIG. 1.

FIG. 3 is a block diagram for circuitry of the mouse of FIGS. 1 and 2.

FIG. 4 is a state diagram showing an example power management algorithm.

FIG. 5 is a state diagram showing another example power management algorithm.

FIG. 6 illustrates transmission of a protocol data unit to a wireless mouse.

FIG. 7 illustrates transmission of a protocol data unit to a wireless keyboard.

FIG. 8 is a block diagram for circuitry of a wireless keyboard according to at least one embodiment of the invention.

FIG. 9 is a state diagram for a wireless computer input device according to at least one embodiment of the invention.

FIG. 10 is a state diagram for a wireless computer input device according to another embodiment of the invention.

#### DETAILED DESCRIPTION OF THE PREFERRED EMBODIMENTS

**[0013]** The present invention provides systems and methods by which a wireless device may detect information about a communication link with another device, and then adopt or modify a power management scheme. The invention is described by example of a desktop computer and wireless computer input device communicating under the BLUETOOTH standard. However, the invention is not limited to these specific types of devices or to the BLUETOOTH standard. The invention may also be implemented with numerous other general purpose or special purpose computing system environments or configurations, with other types of devices, and in devices communicating via other wireless communication standards and/or protocols.

**[0014]** FIG. 1 illustrates one example of a suitable computing system environment 1 in which the invention may be implemented. Shown in FIG. 1, in side view, are a desktop computer 2 having a monitor 4 and keyboard 6. Also shown is wireless mouse 100, which communicates with computer 2 via an RF transceiver within dongle 8. Dongle 8 is connected to a USB or other port of computer 2, and is located externally to computer 2 (as shown). In at least one embodiment, dongle 8 houses the required electronic components and firmware for receiving BLUETOOTH communications from and transmitting BLUETOOTH communications to remote devices (such as a mouse or keyboard). In at least one embodiment, components within dongle 8 convert received BLUETOOTH data to a format which may be passed to computer 2 via a USB port, and similarly convert USB data to a format which may be transmitted by BLUETOOTH link. In particular, dongle 8 contains components and firmware needed to implement the radio, baseband, link manager and L2CAP BLUETOOTH layers for computer 2. In other embodiments, electronic components and firmware for implementing BLUETOOTH communications may be internal to computer 2 and directly connected to a system or other bus without an intermediate USB connection.

**[0015]** FIG. 2 is a side, cutaway view of mouse 100. Mouse 100 may have one or more buttons 102 which can be pressed by a user, a scroll wheel 104, or other types of input controls which can be actuated by a user. The number, arrangement and types of input controls shown are merely exemplary, and other combinations and arrangements are within the scope of the invention. The operation of switches, scroll wheels and other types of input controls is known in the art and thus not further described herein. Mouse 100 may also have one or more internal circuit boards 106 or other substrates upon which various electronic components are connected and physically supported.

**[0016]** These components may include an imaging array 108, a LED or laser source 110, a RF antenna 112, a controller 114 and a battery/power source 126. Other components, not shown in FIG. 2, may include memory and other electrical components. LED or laser source 110 emits light which illuminates an area of a desktop or other surface, and which is imaged by imaging array 108. Images from array 108 are then compared to detect movement of mouse 100 across the desktop or other surface.

**[0017]** FIG. 3 is a block diagram of the internal circuitry of mouse 100 according to one preferred embodiment of the invention. Operation of mouse 100 is controlled by a microprocessor ( $\mu$ P) controller 114. Although controller 114 is shown as a microprocessor, controller 114 could alternatively include state machine circuitry or other suitable components capable of controlling operation of mouse 100 as described herein. Controller 114 communicates with memory 116. Memory 116, which may include volatile and non-volatile memory, is a machine-

readable medium used for storage of software (or firmware) instructions, imaging data and configuration settings (such as power management algorithms discussed in more detail below). Memory 116 may include a rewritable non-volatile component, such as battery-backed SRAM or EEPROM, and/or a non-rewritable component such as ROM. Controller 114 also controls LED or laser source 110 (FIG. 2) and imaging array 108 (FIG. 2), as well as other imaging elements, all of which are represented collectively by block 118. Controller 114 further controls RF communication circuitry 120, and passes data to RF communication circuitry 120 for communication to computer 2 over antenna 112 (FIG. 2). Similarly, data communicated to mouse 100 is received via antenna 112 (FIG. 2) and RF circuitry 120, and transmitted to controller 114. Controller 114 communicates with imaging elements 118, RF circuitry 120 and memory 116 over one or more buses 122, shown collectively as bold bi-directional arrows. Controller 114 also receives electrical signals that correspond to a user's actuation of a mouse button 102 (FIG. 2), scroll wheel 104 (FIG. 2) or other input control. These electrical signals are represented collectively by User Input 124. The various electrical components of mouse 100 are powered by a power source 126, which could include one or more batteries.

**[0018]** Although FIG. 3 shows controller 114, imaging circuitry 118, RF circuitry 120 and memory 116 as discrete components, this need not be the case. For example, one or more of these components might be contained in a single Integrated Circuit (IC) or other component. As another example, controller 114 may include internal program memory such as ROM. Similarly, the herein described functions of these components could be distributed across additional components (e.g., multiple controllers or other components).

**[0019]** The present invention permits mouse 100 to automatically implement a power management algorithm based on parameters of a wireless BLUETOOTH connection with computer 2. For purposes of explanation, two simplified power management algorithms are presented. It is understood, however, that devices according to other embodiments of the invention may have additional and/or more complex power management algorithms.

**[0020]** First power management algorithm 200 is shown in the state diagram of FIG.4. In Active state 202, mouse 100 is configured for immediate use. In other words, Active state 202 assumes that the user is currently moving the mouse, pressing mouse buttons or otherwise providing input to computer 2 with mouse 100. Controller 114 causes LED 110 (FIG. 2) and imaging array 108 (FIG. 2) to create images at a rapid rate. Controller 114 also causes RF circuitry 120 to transmit periodic messages to computer 2 (via dongle 8) containing data or to maintain the connection with computer 2.

**[0021]** After 1 second of no user activity, mouse 100 transitions to Idle state 204. As used herein, "no activity"

includes circumstances when a user is not using the mouse to provide user data to computer 2. In other words, a user is not moving the mouse, pressing a mouse button or rotating a scroll wheel. In some embodiments, mouse 100 is equipped with a proximity sensor (not shown) able to detect the presence of a user hand on or near mouse 100. In such an embodiment, mouse 100 could be configured to treat non-proximity of a user hand as a "no activity" condition. In Idle state 204, Controller 114 causes LED 110 (FIG. 2) and imaging array 108 (FIG. 2) to create images at a reduced rate. Controller 114 also reduces the rate at which RF circuitry 120 transmits messages to computer 2. In particular, messages are only transmitted at an interval sufficiently short to ensure that latency is not noticeable if the user moves mouse 100, pushes a mouse button or otherwise resumes use of mouse 100. Because mouse 100 is in Idle state 204, there is no user data to transmit to computer 2. If there is mouse motion or other user activity while in Idle state 204, the corresponding user data is sent in the next scheduled Idle state transmission, after which mouse 100 returns to Active state 202. In one embodiment, RF messages are transmitted to computer 2 at the rate of one message every 70 milliseconds in Idle state 204. If mouse 100 senses activity (e.g., movement, button press, hand proximity) within 10 minutes after entering Idle state 204, mouse 100 returns to Active state 202. After 10 minutes of no activity, mouse 100 enters Extend Idle state 206. Upon entering Extended Idle state 206, controller 114 sends a message to dongle 8 terminating the connection; in other embodiments, dongle 8 terminates the connection with mouse 100 after mouse 100 has been in Extended Idle state 206 (and therefore not transmitted) longer than the timeout period of dongle 8. In Extended Idle state 206, controller 114 deactivates RF circuitry 120 and no longer transmits to (or listens for transmissions from) computer 2. The imaging rate is also further reduced. Upon sensing movement, a button push, hand proximity or other indication that mouse 100 is needed by a user, mouse 100 returns to Active state 202. If the connection with computer 2 has been terminated, it must be recreated prior to (or as part of) a return to Active state 202.

**[0022]** FIG. 5 shows a second power management algorithm 220. Active state 222 is similar to Active state 202 of algorithm 200 (FIG. 4). The imaging components (LED 110 and imaging array 108) and RF circuitry 120 are activated at rapid rates. After 1 second of no activity, mouse 100 transitions to Idle state 224. Similar to Idle state 204 of algorithm 200, imaging and RF transmission rates are reduced. Unlike algorithm 200, however, mouse 100 remains in Idle state 224 for less time before transitioning to Extended Idle state 226. In one embodiment, mouse 100 transitions back to Active state 222 if activity is detected within 1 minute in Idle state 224. If no activity is detected after 1 minute, mouse 100 transitions to Extended Idle state 226. Similar to Extended Idle state 206 of algorithm 200, controller 114 deacti-

vates RF circuitry 120 and no longer transmits to (or listens for transmissions from) computer 2 while in Extended Idle state 226. Upon detection of user activity, mouse 100 returns to Active state 222. Upon entering Extended Idle state 226, mouse 100 will have terminated the connection with dongle 8, and the connection must be re-established prior to (or as a part of) return to Active state 222.

**[0023]** As can be appreciated from the preceding description, algorithm 220 allows mouse 100 to more quickly deactivate RF circuitry 120, thereby saving power. However, this comes at a cost of more frequently re-establishing the connection with computer 2. If the time to reestablish this connection is too long, the user will perceive a delay between the time he or she attempts to resume input with mouse 100 and the time that the input is acknowledged by computer 2. In some cases this may only be an annoyance, while in other cases it may actually result in data loss (e.g., a mouse click might not be detected by computer 2, and the user might not realize this nondetection).

**[0024]** Accordingly, and as further illustrated with FIG. 6, mouse 100 chooses between power management algorithms 200 and 220 based on one or more parameters of a connection created between mouse 100 and computer 2. When a connection between mouse 100 and computer 2 is initially established, a series of messages are transmitted between mouse 100 and dongle 8. The content, format, sequence and other details of these messages are described in the previously-referenced BLUETOOTH documents, and thus not further described herein. As part of these messages, various Link Manager (LM) protocol data units (PDU) 300 are transmitted from dongle 8 to mouse 100. Contained within one or more PDUs 300 are data identifying features supported by dongle 8 and/or computer 2. Many such features are specific to version 1.1 or to version 1.2 of the BLUETOOTH standard, or to a proprietary feature that may be supported by dongle 8 and/or computer 2. For example, Adaptive Frequency Hopping (AFH) is one feature supported by BLUETOOTH version 1.2 but not by version 1.1. If dongle 8 is a BLUETOOTH version 1.2 device, it will enable AFH by issuing (within a PDU 300) a LMP\_set\_AFH command. If mouse 100 receives such a command, controller 114 thereby determines that computer 2 is communicating via the BLUETOOTH version 1.2 standard.

**[0025]** In at least one embodiment, the default reconnection times for BLUETOOTH version 1.2 is within acceptable limits of latency of mouse 100. For example, mouse 100 may be designed for (or configured for) use by an individual more willing to accept some degree of latency in return for longer battery life. In this embodiment, controller 114 is programmed to implement power management algorithm 220 upon detection of a parameter indicative of a BLUETOOTH v1.2 connection with a computer, and to otherwise implement power management algorithm 200. In another embodiment, mouse

100 is designed (or configured) for a user who is unwilling to accept a degree of latency associated with the default reconnection time of BLUETOOTH v1.2. In this embodiment, however, mouse 100 is further equipped with hardware and/or firmware that permit mouse 100 to reconnect more quickly than the default BLUETOOTH v1.2 connection time, so long as the connection is established with another device that is also equipped with the required hardware and/or firmware. If a mouse 100 in this embodiment receives a PDU 300 from dongle 8 indicating that dongle 8 has the required hardware and/or firmware, controller 114 implements power management algorithm 220. Otherwise, mouse 100 implements power management algorithm 200.

**[0026]** As previously indicated, the invention is not limited to computer mice. FIG. 7 shows a computer keyboard 6' according to another embodiment of the invention. FIG. 8 is a block diagram for internal circuitry for keyboard 6' according to one embodiment of the invention. Operation of keyboard 6' is controlled by microprocessor 152. Microprocessor 152 scans for one or more presses (or releases) of a key by scanning key conductor matrix 154, and upon detecting a key press (or release), causes the appropriate make or break code (s) to be transmitted by RF circuitry 156. Microprocessor 152 also communicates with memory 160, upon which power management algorithms 200 and 220 are stored. Microprocessor 152 and other components of keyboard 6' are powered by battery 158. In one embodiment, microprocessor 152, upon receiving a PDU 300' (FIG. 7) indicating computer 2 communicates via BLUETOOTH v1.2, implements power management algorithm 220. Otherwise, microprocessor implements power management algorithm 200. In another embodiment, keyboard 6' is further equipped with hardware and/or firmware that permit keyboard 6' to reconnect more quickly than the default BLUETOOTH v1.2 connection time, so long as the connection is established with another device that is also equipped with the required hardware and/or firmware. If a keyboard 6' of this embodiment receives a PDU 300' from dongle 8 indicating that dongle 8 has the required hardware and/or firmware, microprocessor 152 implements power management algorithm 220. Otherwise, keyboard 6' implements power management algorithm 200.

**[0027]** FIG. 9 is a state diagram for a controller (such as controller 114 of FIG. 3 or microprocessor 152 of FIG. 8) of an input device configured to operate in accordance with at least one embodiment of the invention. FIG. 9 combines FIGS. 4 and 5 in certain respects. In state 301, the controller is establishing (or re-establishing) a connection with another BLUETOOTH device. When initially establishing the connection, the controller receives one or more PDUs providing parameters for the connection. In state 302, the controller determines, based on parameters identified in state 301, which power management algorithm to implement. If the parameters of the connection correspond to a connection type

that supports sufficiently fast re-establishment of a connection, a first (more power-conserving) algorithm is implemented. In particular, the controller places the input device in Active state 304, which is similar to active state 222 (FIG. 5). After 1 second of no activity, the controller transitions the input device to Idle state 306, which is similar to Idle state 224 of FIG. 5. The input device transitions back to Active state 304 if activity is detected within 1 minute in Idle state 306. If no activity is detected after 1 minute, the input device transitions to Extended Idle state 308. Similar to Extended Idle state 226 of algorithm 220, the controller deactivates RF circuitry and no longer transmits to (or listens for transmissions from) a remote device while in Extended Idle state 308. Upon detection of user activity, the controller transitions the input device to state 301 and establishes or re-establishes a connection. If the connection is a re-established connection with the same remote device, this is determined in state 301, the various connection parameters (previously received when initially establishing the connection) are not retransmitted, and the input device transitions directly from state 301 to state 304. If the connection is with another remote device, the connection parameters for the new remote device are received, and a determination is made at state 302 as to whether the newly connected remote device supports a sufficiently fast re-establishment of a connection. If so, the input device again transitions to state 304.

**[0028]** If it is determined in state 302 after initially establishing a connection with a remote device that the parameters of the just-established connection do not correspond to a connection type supporting sufficiently fast re-establishment of a connection, a second (less power-conserving) algorithm is implemented. In particular, the controller places the input device in Active state 310, which is similar to active state 202 (FIG. 4). After 1 minute of no activity, the controller transitions the input device to Idle state 312, which is similar to Idle state 204 of FIG. 4. The input device transitions back to Active state 310 if activity is detected within 10 minutes in Idle state 312. If no activity is detected after 10 minutes, the input device transitions to Extended Idle state 314. Similar to Extended Idle state 206 of algorithm 200, the controller deactivates RF circuitry and no longer transmits to (or listens for transmissions from) a remote device while in Extended Idle state 314. Upon detection of user activity, the controller transitions the input device to state 301 and establishes or re-establishes a connection. If the connection is a re-established connection with the same remote device, the input device returns to Active state 310 directly from state 301.

**[0029]** FIG. 10 is a state diagram for a computer input device according to another embodiment of the invention. Similar to state 301 of FIG. 9, a controller of a device according to FIG. 10 establishes (or re-establishes) a connection with another BLUETOOTH device in state 401. As part of establishing the connection, the controller receives one or more PDUs providing parameters for

the connection. In state 402, and similar to state 302 of FIG. 9, the controller determines, based on parameters identified in state 401, which power management algorithm to implement. In the embodiment of FIG. 10, however, the controller selects from three or more power management algorithms 404, 406, 408, etc.

**[0030]** Although specific examples of carrying out the invention have been described, those skilled in the art will appreciate that there are numerous variations and permutations of the above described systems and techniques that fall within the spirit and scope of the invention as set forth in the appended claims. These and other modifications are within the scope of the invention as defined by the attached claims.

### Claims

1. A device comprising:

a battery power source;  
a radio transceiver powered by the battery and having components for transmission and receipt of data;  
a memory having instructions stored thereon;  
and  
a controller coupled to the transceiver and to the memory and configured execute the instructions so as to:

create, via the transceiver, wireless connections with remote devices in any of a plurality of connection configurations,  
detect the presence, in a wireless transmission from a remote device, of one or more parameters identifying one of the plurality of configurations, and  
implement, based on the configuration identified, one of a plurality of power management algorithms.

2. The device of claim 1, wherein the controller is configured to detect the presence of one or more parameters by determining if a wireless connection with the remote device has at least one parameter corresponding to an acceptably fast re-connection procedure.

3. The device of claim 2, wherein the controller is configured to:

implement, upon determining the presence of the at least one parameter, a power management algorithm in which the transceiver is deactivated after a first period of device inactivity, and  
implement, upon determining the absence of the at least one parameter, a power manage-

ment algorithm in which the transceiver is deactivated after a second period of device inactivity, the second period being longer than the first period.

4. The device of claim 3, wherein the controller is configured such that the device is inactive if the device is not being used to generate or transmit data based on input from a human user of the device.

5. The device of claim 1, wherein the controller is further configured detect the presence of one or more parameters at the time of establishing a wireless connection with a remote device.

6. The device of claim 1, wherein the plurality of power management algorithms comprises three or more power management algorithms.

7. The device of claim 1, wherein the device is a computer input device.

8. The device of claim 7, wherein the device is a computer mouse.

9. The device of claim 7, wherein the device is a computer keyboard.

10. A method for automatically selecting a power management algorithm in a battery-powered wireless device capable of creating wireless connections with a remote device in any of a plurality of connection configurations, comprising:

establishing a wireless connection with a remote device;  
determining wireless communication features supported by the remote device;  
implementing a first power management algorithm if the remote device supports a first communication feature; and  
implementing a second power management algorithm if the remote device does not support the first feature.

11. The method of claim 10, wherein the first communication feature comprises support for an acceptably fast re-connection procedure.

12. The method of claim 11, wherein:

the first power management algorithm comprises deactivating a transceiver after a first period of wireless device inactivity, and  
the second power management algorithm comprises deactivating the transceiver after a second period of wireless device inactivity, the second period being longer than the first period.

13. The method of claim 12, wherein the wireless device is inactive if the wireless device is not being used to generate or transmit data based on input from a human user.
14. The method of claim 10, further comprising:  
 implementing a third power management algorithm if the remote device does not support the first feature but supports a second feature.
15. The method of claim 10, wherein said determining wireless communication features comprises determining wireless communication features at the time of establishing a wireless connection with a remote device.
16. A machine-readable medium having stored thereon data representing sequences of instructions which, when executed by a processor, cause the processor to perform steps comprising:  
 establishing, from a battery-powered wireless device capable of creating wireless connections with a remote device in any of a plurality of connection configurations, a wireless connection with a remote device;  
 determining wireless communication features supported by the remote device;  
 implementing a first power management algorithm if the remote device supports a first communication feature; and  
 implementing a second power management algorithm if the remote device does not support the first feature.
17. The machine-readable medium of claim 16, wherein the first communication feature comprises support for an acceptably fast re-connection procedure.
18. The machine-readable medium of claim 17, wherein:  
 the first power management algorithm comprises deactivating a transceiver after a first period of wireless device inactivity, and  
 the second power management algorithm comprises deactivating the transceiver after a second period of wireless device inactivity, the second period being longer than the first period.
19. The machine-readable medium of claim 18, wherein the wireless device is inactive if the wireless device is not being used to generate or transmit data based on input from a human user.
20. The machine-readable medium of claim 16, comprising further sequences of instructions which
- cause the processor to perform steps comprising:  
 implementing a third power management algorithm if the remote device does not support the first feature but supports a second feature.
21. The machine-readable medium of claim 16, wherein said determining wireless communication features comprises determining wireless communication features at the time of establishing a wireless connection with a remote device.

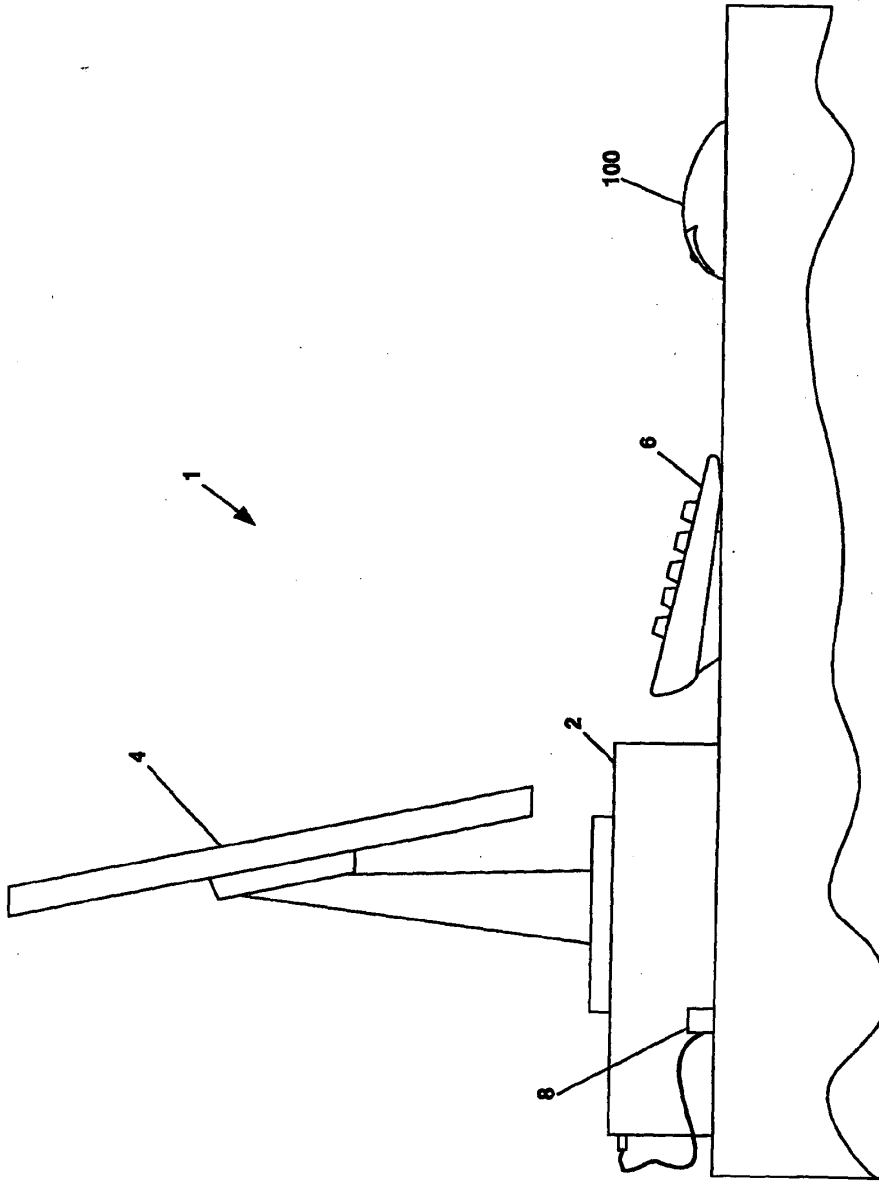

FIG. 1

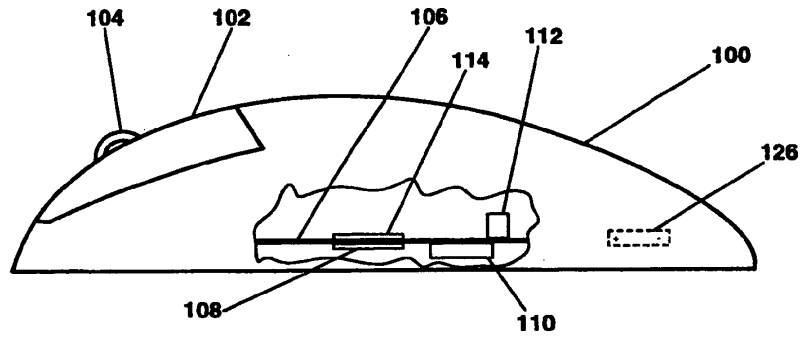

FIG. 2

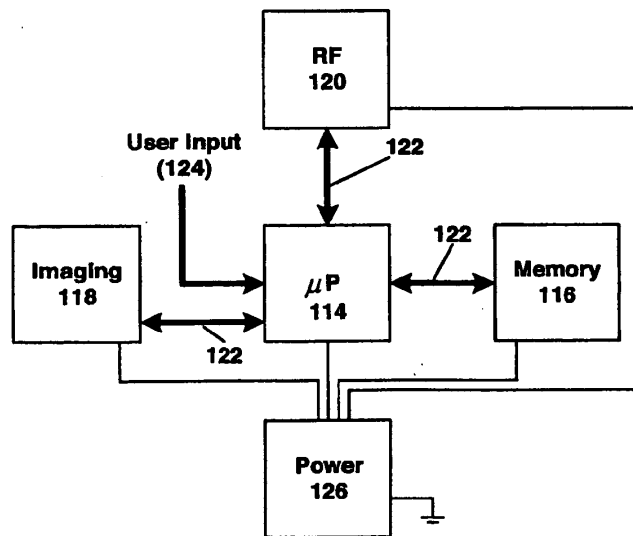

FIG. 3



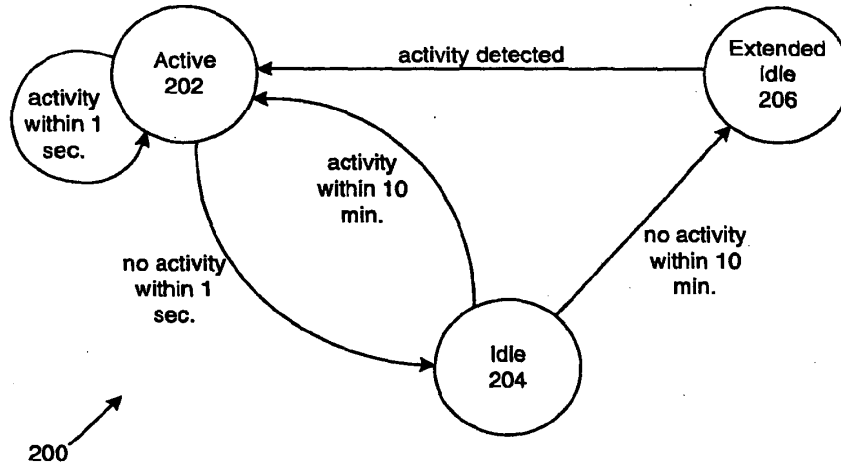

FIG. 4

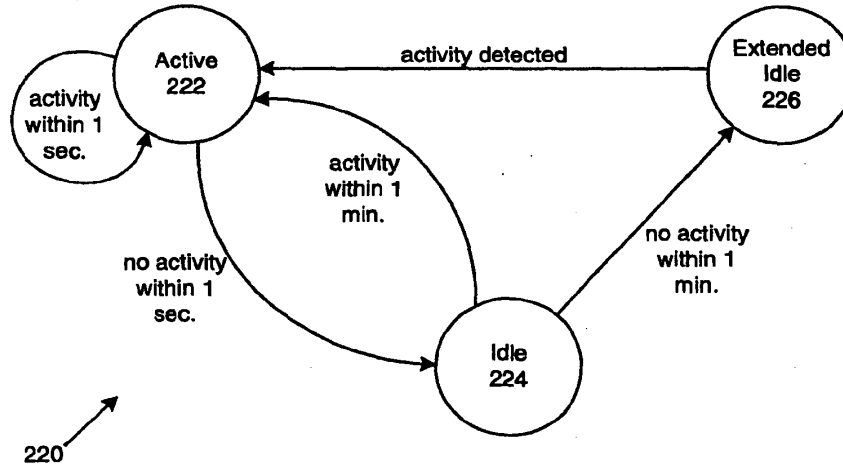

FIG. 5

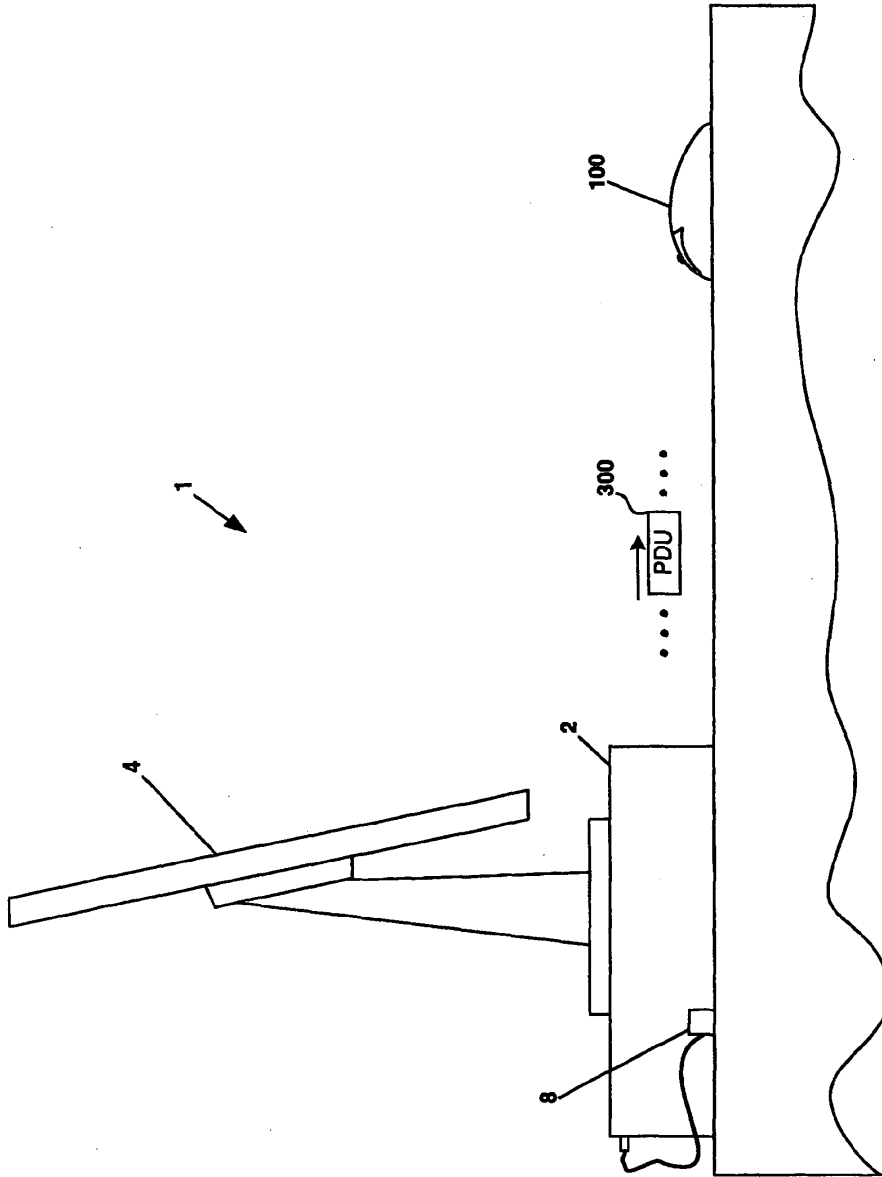

FIG. 6

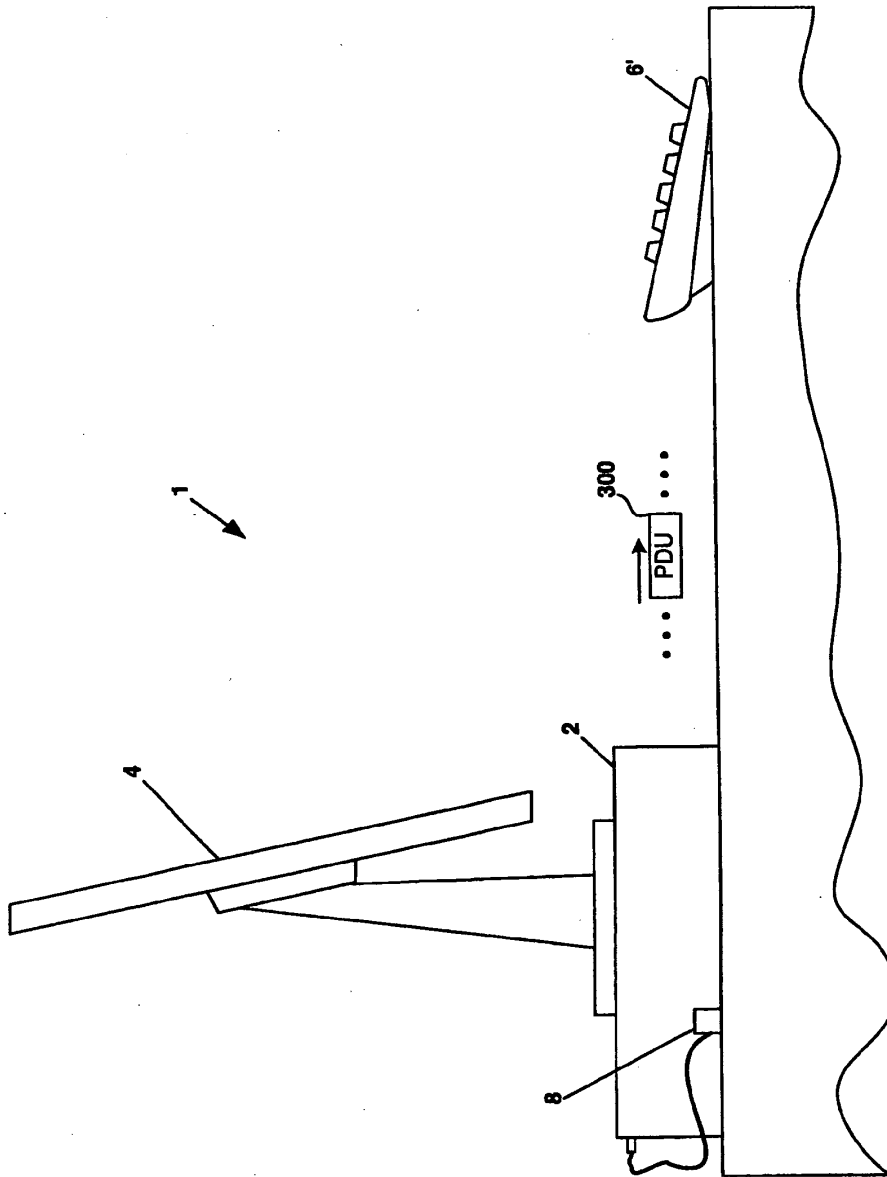
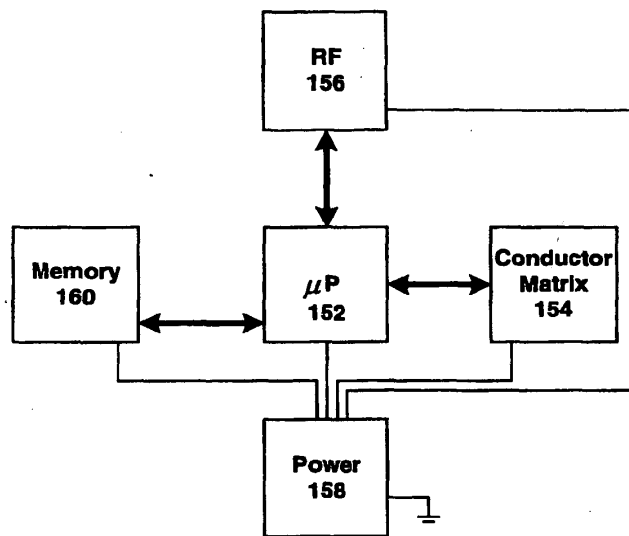
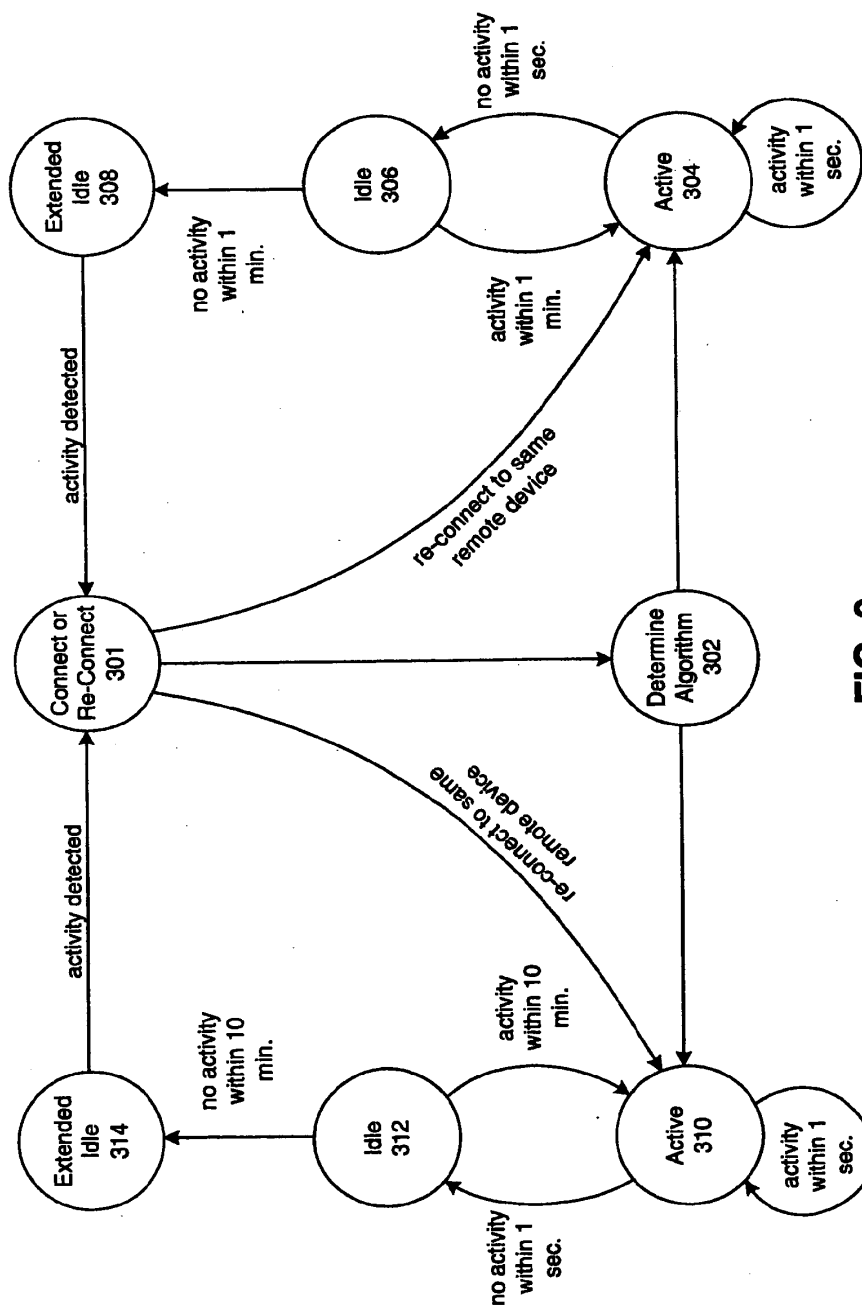

FIG. 7



**FIG. 8**



**FIG. 9**

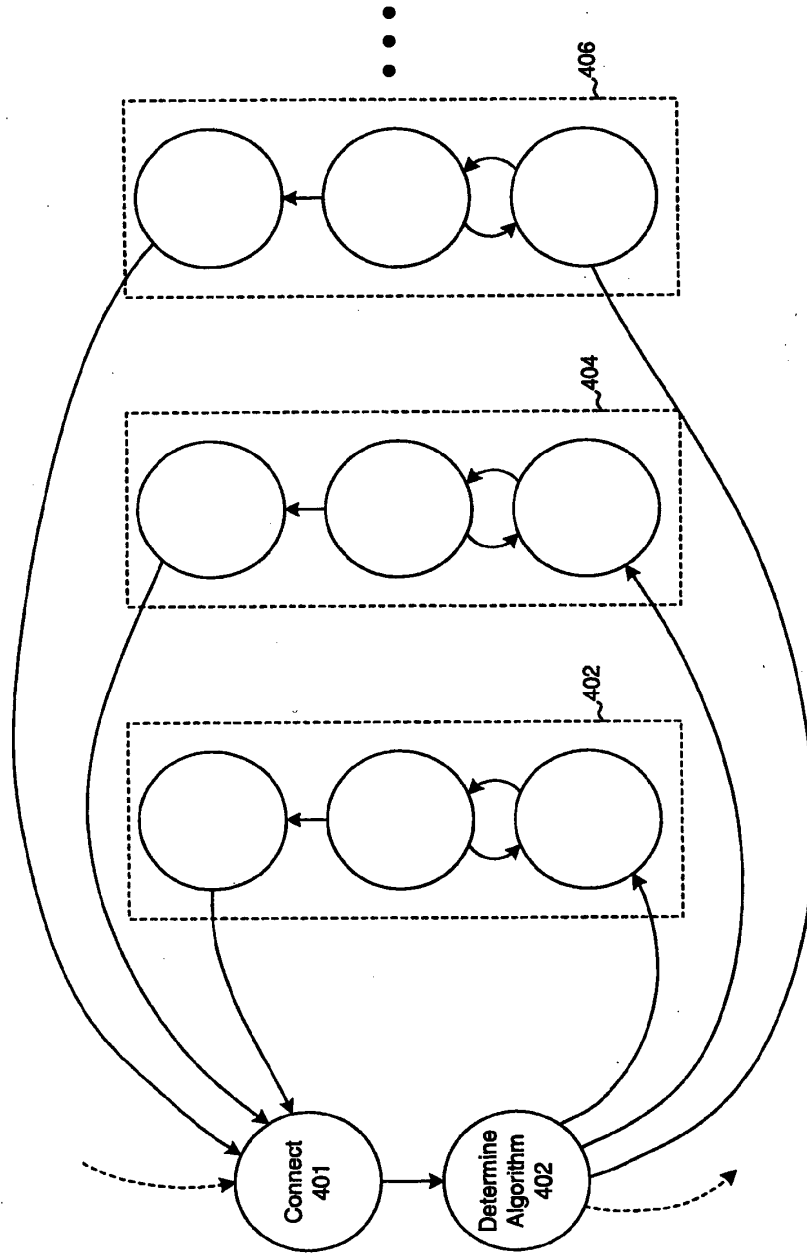

FIG. 10

(12) **UK Patent Application** (19) **GB** (11) **2 431 725** (13) **A**

(43) Date of A Publication **02.05.2007**

(21) Application No: **0618960.9**  
(22) Date of Filing: **26.09.2006**  
(30) Priority Data:  
(31) **60722476** (32) **30.09.2005** (33) **US**  
(31) **11333489** (32) **17.01.2006**

(71) Applicant(s):  
**Harald Philipp**  
**7 Cirrus Gardens, Hamble,**  
**SOUTHAMPTON, Hampshire, SO31 4RH,**  
**United Kingdom**

(72) Inventor(s):  
**Harald Philipp**

(74) Agent and/or Address for Service:  
**D Young & Co**  
**120 Holborn, LONDON, EC1N 2DY,**  
**United Kingdom**

(51) INT CL:  
**H03K 17/955** (2006.01) **H04M 1/73** (2006.01)  
**H04R 1/10** (2006.01) **H04R 5/033** (2006.01)

(52) UK CL (Edition X):  
**G1N NDPX N19B2B**

(56) Documents Cited:  
**GB 2357400 A** **EP 1260082 A1**  
**EP 0564164 A1** **WO 2005/099105 A1**  
**WO 2003/103175 A1** **US 6466036 B1**  
**US 20020068537 A1**

(58) Field of Search:  
UK CL (Edition X) **G1N**  
INT CL **H03K, H04R**  
Other:

(54) Abstract Title: **Headset and headset power management**

(57) A headset (100) includes a capacitive sensor (160) to detect the presence of a user. Capacitive sensing is advantageous since it provides a reliable sensor that can accurately detect the presence or absence of a user either by detecting user proximity or user contact. The sensitivity of a capacitive sensor may be adjusted to account for user movement or changes in environmental conditions such as the presence of water or sweat on the headset to further improve sensing reliability. A control circuit is operable to control a function of the headset depending on whether a user wears the headset or not. Such a circuit may be a power management circuit to reduce power to the headset when a user is not sensed. User presence signals based on capacitive sensing in a headset could also control other functions of the headset or control external devices, such as a phone, to which the headset is connected, either wirelessly or by wires.

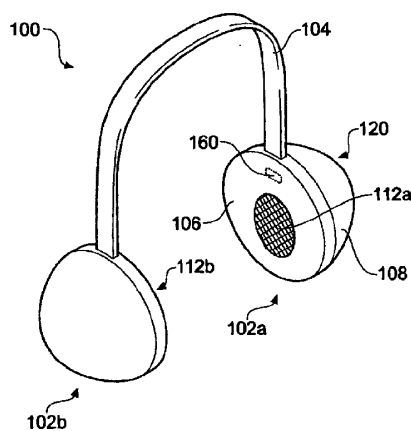

Fig. 1

**GB 2 431 725 A**

Original Printed on Recycled Paper

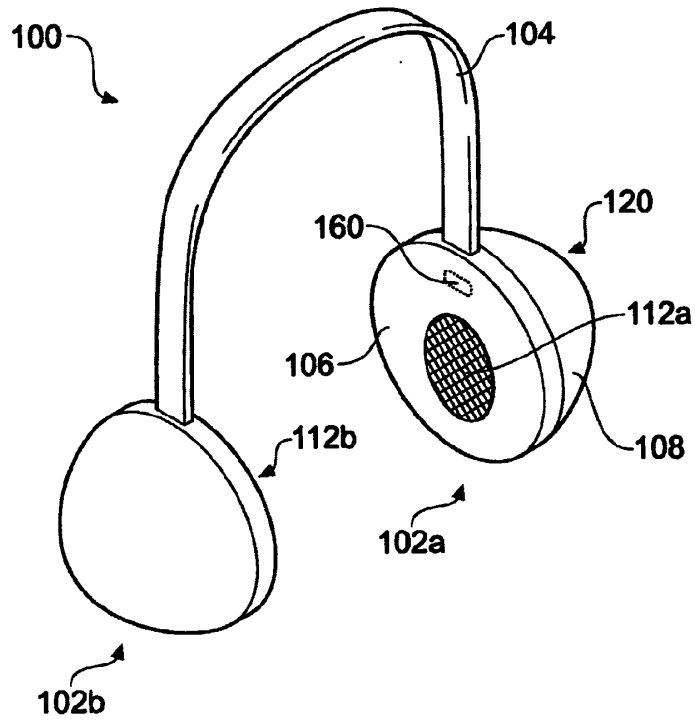

Fig. 1



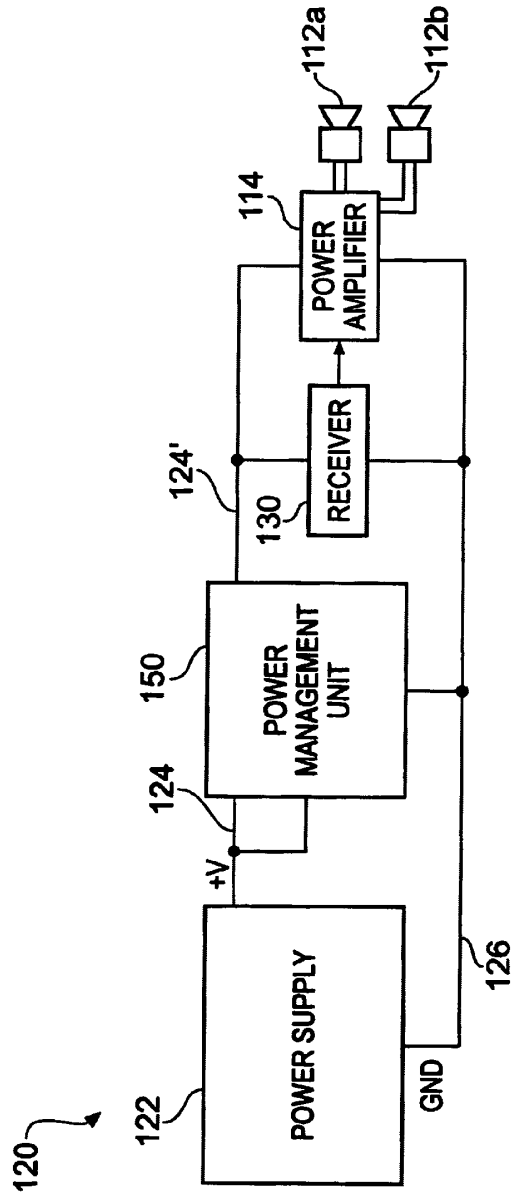

Fig. 2

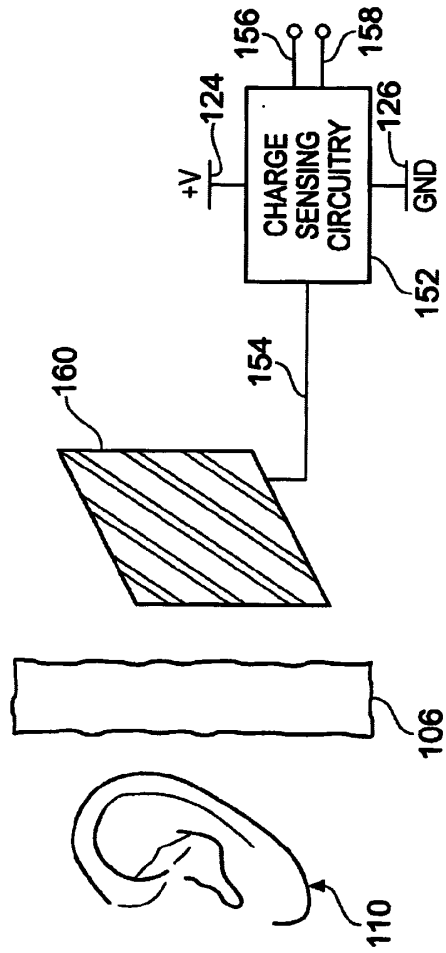

Fig. 3

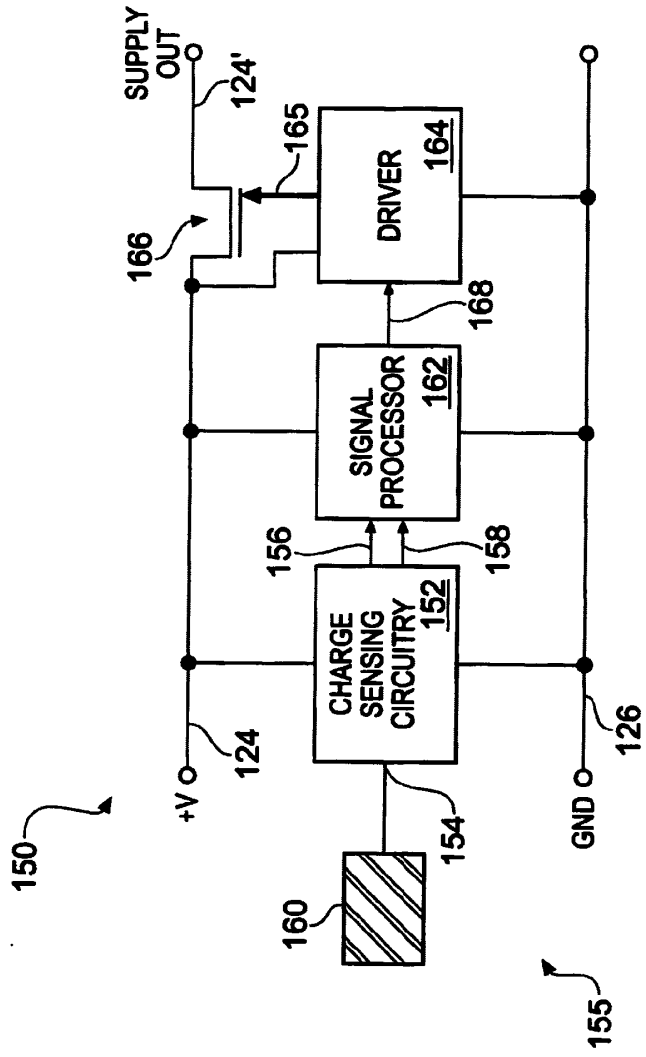

Fig. 4

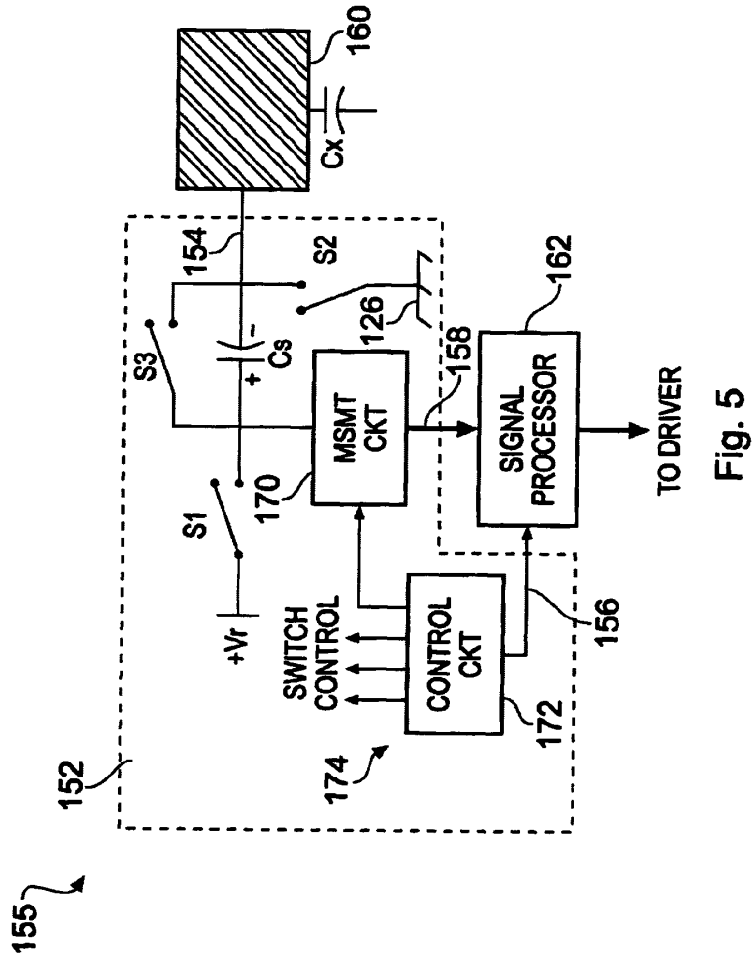

Fig. 5

STEP	S1	S2	S3	FUNCTION
A	-	X	X	RESET ALL
B	-	-	-	DEADTIME
C	X	-	-	CHARGE-TRANSFER
D	-	-	-	DEADTIME
E	-	X	-	HOLD
F	-	X	-	MEASURE

LOOP

Fig. 6

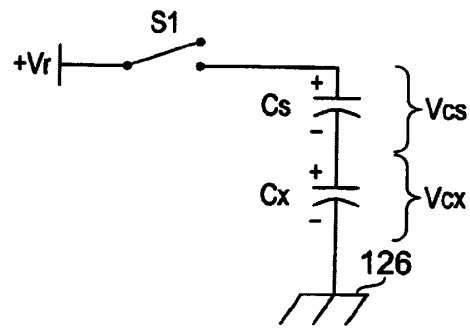

Fig. 7

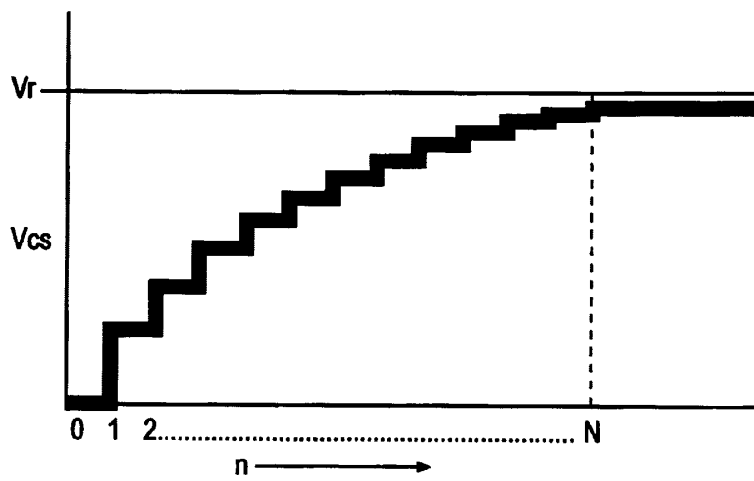

Fig. 8

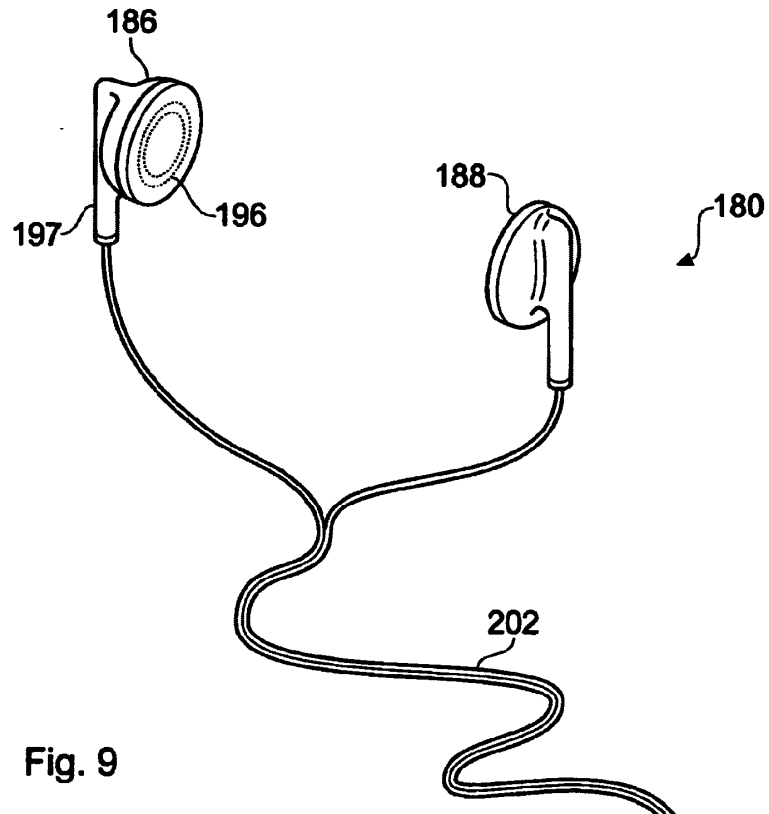
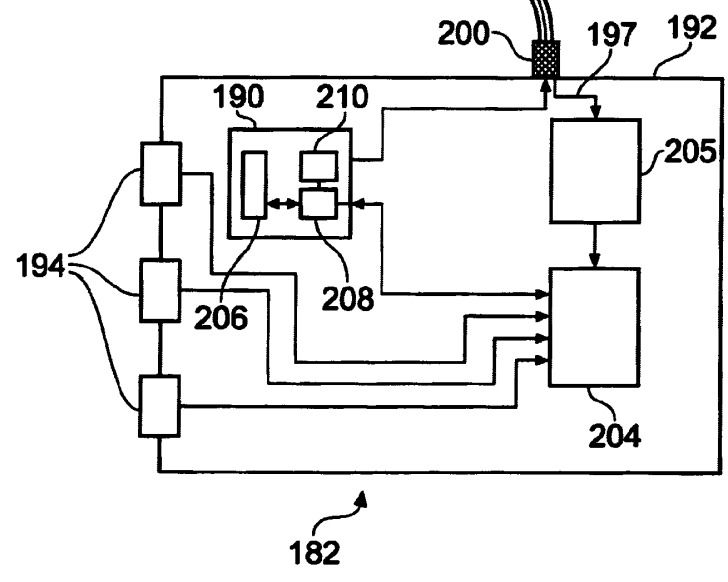

Fig. 9



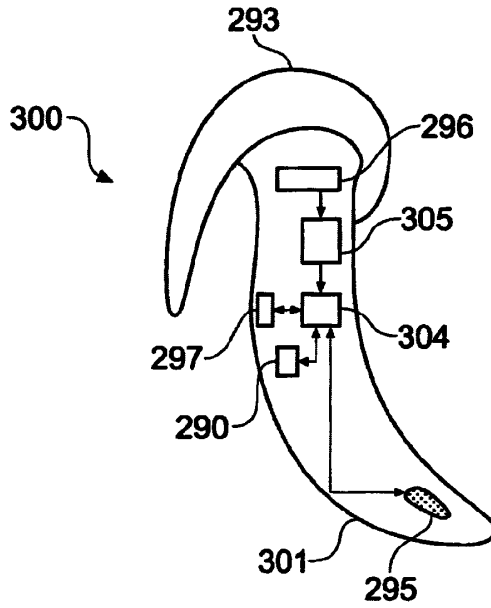

Fig. 10A

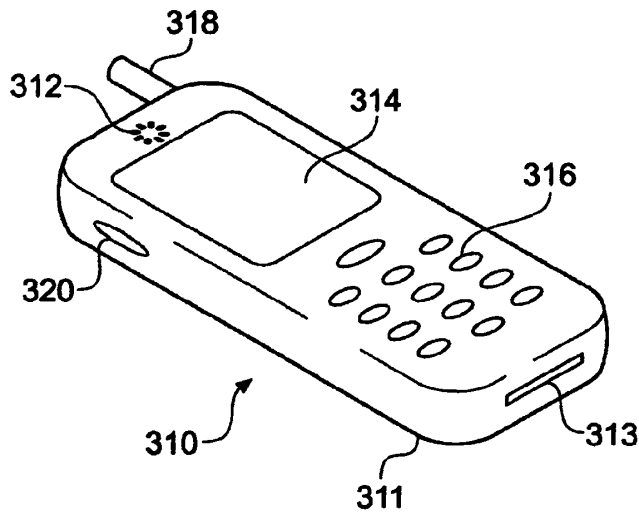

Fig. 10B



**Headsets and headset power management****Field**

The invention relates to apparatus comprising headsets and more especially but not  
5 exclusively to power management and/or function control of such apparatus. In  
particular, the invention relates to power management in a headset that comprises one  
or more circuit elements that consume electrical power such as, for example, a  
Bluetooth™ or other wireless receiver.

**Background**

10 Many different types of headset have been designed by numerous manufacturers with  
various types of end user application in mind. For example, stereo headphones for  
listening to music have been around for many years, as have ear pieces for use with  
hearing aids, portable radios and the like [1-3].

15 Recently, many new types of headset that can be worn by a user have been developed  
with a view to using them with mobile cellular telephones or other portable electronic  
devices. Numerous headset designs have been created to enable a user to use such a  
portable electronic device without the need to hold the electronic device: the so-called  
“hands-free” mode of operation.

20 Many of the recently developed headsets are cordless devices that incorporate a  
Bluetooth™ receiver or a Bluetooth™ receiver/transmitter. Bluetooth™ is a radio-  
frequency communications standard developed by a group of electronics  
manufacturers that allows various types of electronic equipment to interconnect,  
without the need for wires, cables or detailed user intervention. The Bluetooth™  
standard enables various electronic devices to inter-operate, since all electronic  
25 products that use Bluetooth™ have to use an agreed standard that dictates when data  
bits are sent, how many data bits are sent at any one time, how data transmission errors  
are handled, etc.

Whilst improved design has led to improvements in the size and weight of headsets, the functionality of headsets has increased dramatically. This has increased pressure on engineers to consider how most efficiently to use the electrical power available, particularly for cordless battery-operated headsets where battery life and available  
5 power are limited.

With a view to improving power usage, various manufacturers have developed headsets that incorporate power management features.

One prior art design is that of the Sony™ MDR-DS8000 headset available from Sony™ Corporation. In this headset, an electromechanical switch is provided that  
10 changes state when the ear pieces are pulled apart when the headset is being put on by a user. This is done by the headband expanding and pulling on a switch mechanism.

In another prior art design [4], an inductive noise signal is provided by a metallic ring built into an ear piece when the ear piece contacts a user. This signal is used to detect the presence or absence of a user to determine whether or not to power-down a signal  
15 amplifier.

While these known power-saving headsets fulfil the desired function, they are not without various drawbacks. For example, mechanical switches are relatively bulky and expensive, and they can also suffer from long-term reliability problems. Moreover, the mechanical headband switch approach is not transferable to non-headband based  
20 headsets such as single-ear devices, for example ones that operate wirelessly by Bluetooth™ or otherwise. Sensing user presence based upon detecting inductive noise is also less than ideal, particularly given the random nature of such noise and its amplitude variability according to differing physical conditions, such as the degree of electrode contact with the user (e.g. if a user is jogging), prevailing environmental  
25 conditions (e.g. if a user is sweating or is exposed to rain), etc.

Summary of the invention

According to a first aspect of the invention, there is provided an apparatus comprising: a headset including a sensing element; a capacitance measurement circuit operable to measure the capacitance of the sensing element; and a control circuit operable to  
5 determine whether a user is wearing the headset based on a measurement of the capacitance of the sensing element, and to control a function of the apparatus according to whether the headset is being worn.

Thus a simple and reliable way of controlling functions of an apparatus in dependence on whether or not a headset is being worn is provided. Various functions can be  
10 controlled. For example, the controlled function may be a power saving function. Alternatively, the function may relate to activation of an audio amplifier, activation of a wireless communications transceiver, outputting of an audio signal by an audio generator, and/or the inhibition of user input signals, for example.

Any form of capacitance measurement circuitry may be employed, for example  
15 circuitry based on RC circuits, relaxation oscillators, phase shift measurements, phase locked loop circuitry, capacitive divider circuitry may be used. Capacitance measurement based on charge transfer techniques in particular are well suited to this application. Thus the capacitance measurement circuit may include a sample capacitor and be operable to transfer charge from the sensing element to the sample capacitor to  
20 generate an electric potential at the sample capacitor for measuring. Furthermore, the capacitance measurement circuit may comprise a switch operable to transfer a burst of charge packets sequentially from the sensing element to the sample capacitor prior to a measurement of the electric potential being made.

The control circuit may be operable to determine whether a user is wearing the headset  
25 by comparing a measured capacitance of the sensing element to one or more predetermined threshold values. The measured capacitance may be an absolute value of capacitance or a differential measurement of capacitance, e.g. a difference from an earlier measured value.

The capacitance measurement circuit may be external to the headset, e.g. in a base unit, or may be internal to the headset. Furthermore, the control circuit and/or a circuit element providing the function to be controlled may be external to the headset, e.g. in a base unit, or may be internal to the headset.

- 5 According to a second aspect of the invention, there is provided a method of operating an apparatus comprising a headset, the method comprising: measuring the capacitance of a sensing element in the headset; determining from the measured capacitance whether a user is wearing the headset; and controlling a function of the apparatus in response to determining whether the headset is being worn.
- 10 The measuring the capacitance of the sensing element may include: transferring charge from the sensing element to a sample capacitor; measuring the electric potential at the sample capacitor; and determining the capacitance of the sensing element from the measured electric potential of the sample capacitor. Furthermore, the transferring charge from the sensing element to a sample capacitor may comprise transferring a
- 15 burst of charge packets in sequence from the sensing element to a sample capacitor.

The determining whether a user is wearing the headset or not may comprise comparing the measured capacitance of the sensing element to one or more predetermined threshold values in order to determine whether the capacitance of the sensing element has been changed due to the proximity of a user. Furthermore, the method may include

20 adjusting one or more of the threshold values in response to changes in operating conditions.

According to a third aspect of the invention, there is provided an energy saving headset comprising a power management unit operable to reduce the power consumption of the headset when it is not being worn by a user. The power management unit includes

25 a sensing circuit coupled to a capacitive sensor. The sensing circuit is operable to measure the capacitance of the capacitive sensor and to generate a user presence signal in dependence upon the measured capacitance. The user presence signal is indicative of whether a user is present or not. The power management unit is operable in

accordance with the user presence signal to control one or more circuit elements that are provided in the headset, typically a power control.

Power control will normally be by switching the circuit element on or off. However, the power control need not be a simple binary function, but may include reducing the power to a stand by level for example, or reducing the power supplied to a power amplifier so that it is still operable but at reduced gain, e.g. to suppress feedback that may otherwise occur. However, it will be understood that the user presence signal can be used, by the power management unit or otherwise, to control other functions not directly related to power. For example, the user presence signal can be used to control other functions of the headset, or to output an external output signal that can be received by other devices to which the headset is connected, either wirelessly or wired. For example, removal of the headset may be used to pause playing activity of a sound or video track, whereafter putting the headset back on will cause resumption of playing responsive once more to the user presence signal. Another example would be when placing the headset on by the user causes playback to be switched from an external loudspeaker to the headset speaker. Headsets with ambient noise canceling are also well known. For example, such headsets are successful in reducing flight noise and for increasing the fidelity of classical music playback. It is also well known that the noise canceling circuitry consumes significant power, so selective activation and deactivation of the noise canceling circuitry is one useful application of the invention.

Accordingly the invention further relates to a headset with reduced power consumption, comprising: at least one circuit element requiring power; a capacitive sensor operable to provide a capacitance measurement signal; and a power management unit including a sensing circuit operable to generate a user presence signal responsive to the capacitance measurement signal indicating whether the headset is being worn and operable to control the at least one circuit element dependent on said user presence signal, or to output an external output signal that is dependent on said user presence signal for receipt by another device to which the headset is connected. The at least one circuit element may control a function of the headset, such as its power delivery. Alternatively, the at least one circuit element may

be used indirectly to control the function of an external device by transmitting the user presence signal externally.

5 According to a fourth aspect of the invention, there is provided a method of operating a headset in order to reduce power consumption. The method comprises measuring the capacitance of a capacitive sensor, determining from the measured capacitance whether a user is present or not, and powering-down one or more circuit elements in the headset in response to determining that no user is present in order to reduce the power consumption of the headset.

10 As mentioned above, the user preference detection may be used to control functions other than power consumption. Consequently, the invention also relates to a method of operating a headset, the method comprising: measuring the capacitance of a capacitive sensor; determining from the measured capacitance whether a user is present or not; and controlling a function of the headset, or outputting an external output signal that  
15 can be received by another device to which the headset is connected, in response to determining whether the user is present or not. The external device to which the headset is connected may be connected wirelessly or by wires.

The claimed capacitive sensing solution provides a simple, inexpensive and reliable sensor which is superior to the prior art mechanical solution described above.

20 The capacitive sensor can operate either on proximity or direct contact depending on how its sensitivity is calibrated. The sensitivity of the capacitive sensor may also be dynamically adjusted to account for changes in environmental conditions, such as, for example, humidity.

25 According to a further aspect of the invention there is provided a headset with reduced power consumption, comprising: at least one circuit element requiring power; a capacitive sensor operable to provide a capacitance measurement signal; and a power management unit including a sensing circuit operable to generate a user presence signal responsive to the capacitance measurement signal indicating whether the

headset is being worn and operable to control the at least one circuit element dependent on said user presence signal.

5 The sensing circuit may include a sample capacitor and be further operable to transfer charge from the capacitive sensor to the sample capacitor to generate an electric potential at the sample capacitor for measuring.

The headset may further comprise at least one switch operable to transfer a burst of charge packets sequentially from the capacitive sensor to the sample capacitor prior to any measurement of the electric potential being made.

10

The sensing circuit may comprise a consensus filter for generating the user presence signal.

15 The sensing circuit may further be operable automatically to perform a self-calibration operation.

The capacitive sensor may comprise an electrode that is electrically isolated from the user when the headset is being worn.

20 For example, the sense electrode of the capacitive sensor may be located under the casing of a traditional hi-fi format twin ear headset or within the housing of an ear-piece that forms part of a single ear or twin ear modern-style ear-piece headset of a portable music player, Bluetooth™ accessory headset, hearing aid, etc. The sense electrode of the capacitive sensor could alternatively be provided on the headband of a  
25 traditional hi-fi format twin ear headset. It could also be provided in the form of a conductive strip within the speaker area of a headset. In general it is desirable that the sense electrode of the capacitive sensor is provided relatively near to the user's skin, since signal strength correlates with proximity.

30 At least one of the circuit elements may comprise a Bluetooth™ receiver.

According to a still further aspect of the invention there is provided a method of operating a headset in order to reduce power consumption, the method comprising: measuring the capacitance of a capacitive sensor; determining from the measured capacitance whether a user is present or not; and powering down one or more circuit  
5 elements in the headset in response to determining that no user is present in order to reduce the power consumption of the headset.

The measuring the capacitance of the capacitive sensor may include: transferring charge from the capacitive sensor to a sample capacitor; measuring the electric  
10 potential at the sample capacitor; and determining the capacitance of the capacitive sensor from the measured electric potential of the sample capacitor.

The transferring charge from the capacitive sensor to a sample capacitor may comprise transferring a burst of charge packets in sequence from the capacitive sensor to a  
15 sample capacitor.

The determining whether a user is present or not may comprise comparing the measured capacitance of the capacitive sensor to one or more predetermined threshold values in order to determine whether the capacitance of the capacitive sensor has been  
20 changed by the proximity of the user.

The method may comprise adjusting one or more of the threshold values in response to changes in operating conditions.



**Brief description of the drawings**

For a better understanding of the invention and to show how the same may be carried into effect, reference is now made to the accompanying drawings in which:

5 Figure 1 shows a schematic diagram of an energy saving headset according to an embodiment of the present invention;

Figure 2 shows a schematic diagram of headset electronics for use in various headsets made in accordance with the present invention;

Figure 3 shows a schematic diagram illustrating the physical configuration of various components for use in various headsets made in accordance with the present invention;

10 Figure 4 shows a power management unit for use in various embodiments of the present invention;

Figure 5 shows a charge transfer capacitance measurement circuit for use in various embodiments of the present invention;

15 Figure 6 shows a switching table indicating the switching sequence of the switches used in the charge transfer capacitance measurement circuit of Figure 5;

Figure 7 shows a schematic circuit diagram depicting an electrically equivalent rearrangement of a part of the charge transfer capacitance measurement circuit of Figure 5;

20 Figure 8 shows a plot of voltage across capacitor  $C_s$  of the charge transfer capacitance measurement circuit of Figure 5 as a function of cycle number during a burst-mode operation;

Figure 9 shows a schematic diagram of an apparatus according to another embodiment of the invention; and

25 Figures 10A and 10B show schematic diagrams of an apparatus according to a further embodiment of the invention.

Detailed description

Figure 1 shows a schematic diagram of an energy saving headset 100. The headset 100 comprises first and second casings 102a and 102b housing respective loudspeakers 112a and 112b for reproducing stereo sound. The casings 102a and 102b are physically  
5 connected together by a headband 104 that comprises a recess for housing electrical cabling (not shown) which connects the loudspeaker 112b in the second casing 102b to headset electronics 120 housed in the first casing 102a.

The casings 102a and 102b are formed of an outer casing cover 108 and an inner cover 106 that contacts a user's ear when the headset 100 is being worn. The casing cover  
10 108 may be used to mount various user operable controls (not shown), such as, for example, volume controls, channel controls etc. The cover 106 can be provided over padding for user comfort and be made from various materials, including, for example, a flexible water-resistant polymeric sheet material. An opening in the cover 106 exposes the loudspeaker 112 to the user's respective ear when the headset 100 is being  
15 worn.

The headset electronics 120 provides a power management function in order to lessen power consumption when no user is wearing the headset 100. The headset electronics 120 uses capacitive sensing in order to detect whether or not a user is wearing the headset 100. In addition to power management, the headset electronics 120 may also  
20 provide various other functions, such as those described below.

Capacitive sensing is achieved by the headset electronics 120 measuring the capacitance of a sense plate 160, for example, by using a charge transfer technique such as that described in more detail below. The sense plate 160 is provided in the headset 100 underneath the cover 106. Hence, in this embodiment, the sense plate 160  
25 does not contact the user when the headset is being worn, and is used to detect user presence by sensing proximity of the user rather than any physical contact of the user with the sense plate 160. This makes the headset 100 as comfortable as a conventional headset that does not incorporate a power management function, and also enables a

conventional headset design to be used since the cover 106 does not need to be cut or otherwise further modified to accommodate a touch sensor.

Figure 2 shows a schematic diagram of headset electronics 120 for use in various embodiments of headsets made in accordance with the present invention. The headset  
5 electronics 120 includes a power supply 122 for powering a radio frequency (RF) receiver 130 that receives and decodes signals that are transmitted to the headset 100. The headset electronics 120 also includes a power amplifier 114 which amplifies audio signals that are decoded by the receiver 130 and feeds the amplified audio signals to respective loudspeakers 112a and 112b for stereo sound reproduction. The receiver  
10 130 may be a conventional Bluetooth™ receiver, or other wireless receiver such as Zigbee™. Reference to wireless includes the possible use of an infrared link or radio link.

The power supply 122 can include a rechargeable battery plus associated charging and a power conditioning circuit. In alternative embodiments, the headset 100 can be  
15 powered by conventional batteries or from an external power source. However, in the embodiment of Figure 2, use of a rechargeable battery conveniently allows for cordless operation of the headset 100.

A positive output of the power supply 122 is electrically coupled to a positive supply rail 124. The negative or ground output of the power supply 122 is electrically coupled  
20 to a negative supply rail 126. The electronic components that form the headset electronics 120 are electrically coupled to the negative supply rail 126. In addition, a power management unit 150 is provided that is operable to electrically connect the positive supply rail 124 to a disconnectable portion of the positive supply rail 124'. Operation of the power management unit 150 to disconnect the portion of the positive  
25 supply rail 124' from the positive supply rail 124 cuts off the power supply to any electronic components that are powered from the portion of the positive supply rail 124', thereby reducing the total power that is consumed by the headset electronics 120 when the power management unit 150 is in a disconnect state.

When the power management unit 150 is in the disconnect state, only the power management unit 150 itself need draw any power from the power supply 122. In variants of this embodiment, any electronic components that need to be permanently in an active state are electrically connected between the positive supply rail 124 and the negative supply rail 126, while any electronic components that can be switched off when the headset 100 is not being worn are electrically connected between the portion of the positive supply rail 124' and the negative supply rail 126.

Figure 3 shows a schematic diagram illustrating the physical configuration of various components that form part of the headset 100 shown in Figure 1.

10 A portion of the cover 106 is shown in proximity to the ear of a user 110. The cover 106 separates the user 110 from the sense plate 160 that is provided in the headset 100.

Also shown, electrically coupled to the sense plate 160 by sense plate connector 154, is a charge sensing circuit 152 that forms a part of the power management unit 150. The charge sensing circuit 152 is electrically connected between the positive supply rail 124 and the negative supply rail 126 in order to draw power from the power supply 122. Two outputs, a control output 156 and a measurement output 158, are provided by the charge sensing circuit 152, these are further described below in connection with various components of the power management unit 150.

Figure 4 schematically shows a power management unit 150 for use in various embodiments of the present invention. The power management unit 150 comprises a charge sensing circuit 152 that is electrically coupled to a sense plate 160 by way of a sense plate connector 154.

The charge sensing circuit 152 is electrically connected between the positive supply rail 124 and the negative supply rail 126, and is operable to measure the capacitance of the sense plate 160. The charge sensing circuit 152 has two outputs 156 and 158. One of these outputs is a measurement output 158, the voltage level of which indicates the measured capacitance of the sense plate 160. The other output is a control output 156 that is used to indicate to a signal processor 162 when the voltage level of the measurement output 158 is available to be read.

The signal processor 162 is electrically connected between the positive supply rail 124 and the negative supply rail 126. It is operable to process measured capacitance values and to determine whether those measured capacitance values for the sense plate 160 indicate the presence of the user 110, a process that is described in greater detail  
5 below. The signal processor 162 provides a control output 168 whose output level indicates the presence of a user (output level = logic one) or the absence of a user (output level = logic zero).

An optional driver circuit 164 is also provided in the power management unit 150 for embodiments where the output current that can be provided by the control output 168  
10 is not sufficient to drive field-effect transistor (FET) switch 166 directly. The FET switch 166 is operable to electrically couple the positive supply rail 124 to the portion of the positive supply rail 124' in order to activate electrical components connected to the latter supply rail 124'. Where such a driver circuit 164 is provided, it is itself powered by drawing power from between the positive supply rail 124 and the negative  
15 supply rail 126.

Optionally, the charge sense circuit 152 and the signal processor 162 may be provided together by using an integrated circuit (IC) device, such as, for example, the QT110 sensor IC available from Quantum Research Group of Hamble, Great Britain.

Figure 5 shows a charge transfer capacitance measurement circuit 155. A similar  
20 charge transfer capacitance measurement circuit is described in US patent number US-B1-6,466,036 [5], and the content of this document is hereby incorporated herein by reference in its entirety.

Although any suitable capacitance measurement technique may be used, the circuit of the charge transfer capacitance measurement circuit 155 is well suited for  
25 implementing on an IC. Additionally, the measuring of capacitance using a charge transfer technique can be advantageous because it provides superior performance at a lower manufacturing cost when compared to various other user presence detection techniques.

A first switching element, S1, is used to drive electric charge through both a sampling capacitor, Cs, and a capacitance to be measured, Cx, during Step C (as summarised in the table of Figure 6). This leaves residual charges on both Cs and Cx after S1 opens in step D of Figure 6. Kirchoff's current law and the principle of charge conservation dictate that these charges, Qx and Qs, are equal. However, because  $C_s \gg C_x$ , a greater residual voltage is found on Cx, and conversely, a lesser voltage is found on Cs. Figure 7 reveals that the arrangement of Figure 5 may be viewed as a capacitive voltage divider when considering the closure of S1 in step C of Figure 6.

In Figure 5, a sense plate 160 is explicitly depicted to indicate that in uses of the invention the presence or motion of an object that is not part of the apparatus of the invention is to be sensed by a capacitive measurement. Although the Figures sometimes show both a sense plate 160 and an unknown capacitance, Cx, it will be understood to those skilled in the art that in these depictions Cx is the capacitance of the sense plate 160 to free space or to an electrical ground. The value of Cx is modified by the presence or proximity of a user.

Again referring to the depiction of Figure 5, a second switching element, S2, is used to clear the voltage and charge on Cx, and also to allow the measurement of Vcs, the voltage across Cs. It may be noted that the use of S2 allows S1 to be cycled repeatedly in order to build up the charge on Cs. This provides a larger measurable voltage value and greater accuracy, increasing sense gain or sensitivity without the use of active amplifiers. A third switching element, S3, acts as a reset switch and is used to reset the charge on Cs prior to beginning a charge transfer burst as explained below.

A preferred control circuit 172 controls the switching sequence and also the operation of the measurement circuit 170. The control circuit 172 is operable to switch the switches S1, S2 and S3 using the schematically-illustrated control lines 174. A signal processor, indicated as block 162, may be required to translate an output of the measurement circuit into a usable form. For example, this may involve converting cycle counts to a binary representation of signal strength. The signal processor 162 may also contain linear signal processing elements such as filters and/or non-linear

functions such as threshold comparisons, so as to provide an output suitable for an intended application.

Although the control circuit 172 and signal processor 162 are depicted only schematically in Figure 5, it will be clear to those skilled in the art that such circuit  
 5 elements may also be used with circuit elements depicted elsewhere (e.g. as indicated by the bold output arrow from the measurement circuit 170), and that various circuit elements and connections have been omitted only in the interest of clarity of presentation.

The table of Figure 6 shows the switching sequence used in one implementation using  
 10 the circuit of Figure 5. First, in step A, switching elements S2 and S3 are closed to clear charge on Cs and Cx. After a suitable pause in step B during which all switches are held open, S1 is closed to drive charge through Cs and Cx (Step C). The resulting first voltage increment across Cs is defined by the capacitive divider equation:

$$\Delta V_{cs(1)} = V_r C_x / (C_s + C_x) \quad (1)$$

15 where  $V_r$  is the reference voltage connected to S1.

In step D, all switches are held open.

In Step E, S2 is closed, and  $\Delta V_{cs}$  appears as a ground-referenced signal on the positive, distal, terminal of Cs. Dead-time steps B and D are employed to prevent  
 20 switch cross-conduction, which would degrade the charge build-up on Cs. The dead-time can be quite short, measuring a few nanoseconds, or longer if desired. Steps B through E may be repeated in a looping manner, to provide a "burst" of charge transfer cycles. After a suitable charge transfer burst length, the charge transfer cycle is terminated and  $V_{cs}$  is measured in the aforementioned manner, e.g. by using an  
 25 analogue-to-digital converter (ADC), in Step F, with S2 closed and the other switches open. Following the measurement of  $V_{cs}$ , S3 may also be closed to reset Cs in preparation for the next charge transfer burst, during which a further plurality of packets of charge will be transferred from Cx to Cs.

In an alternative variant, steps E and F may be combined so that a measurement is made at each charge transfer cycle. By combining steps E and F, which are functionally identical, the measurement circuit 170 can be made to consist of a simple voltage comparator with a fixed reference. In such cases, the looping action of the charge transfer cycles is terminated when the voltage comparison indicates that Vcs has risen above a selected threshold value. The number of cycles taken to reach this point becomes the signal reading which is indicative of the value of the capacitance Cx. This technique is explained further below.

During the repeating loop of steps B through E, voltage builds up on Cs but not on Cx. Cx is continuously being discharged in step E, and hence Cx cannot build up an increasing amount of charge. However, Cs freely accumulates charge, so that the resulting incremental voltage is dependent on the difference in the voltages Vr and Vcs as follows:

$$\Delta V_{cs}(n) = K(V_r - V_{cs}(n-1)) \quad (2)$$

where Vr is a supply voltage that may be a fixed reference voltage; n is the charge transfer cycle number; and  $K = C_x / (C_s + C_x)$ .

The final voltage across Vcs is equal to the sum of the initial value of Vcs plus Vcs(N) which is equal to the sum of all of the subsequent values of ΔVcs. That is:

$$V_{cs}(N) = \Delta V_{cs}(1) + \Delta V_{cs}(2) + \Delta V_{cs}(3) + \dots + \Delta V_{cs}(N) \quad (3)$$

or,

$$V_{cs}(N) = \sum \Delta V_{cs}(n) = K \sum (\Delta V_r - V_{cs}(n-1)) \quad (4)$$

where the summation runs over the range from n=1 to n=N.

During each charge transfer cycle, the additional incremental voltage on Vcs is less than the increment from the prior cycle and the voltage build-up can be described as a limiting exponential function:

$$V(N) = V_r - V_r e^{-dn} \quad (5)$$



where  $d$  is a time scaling factor. This produces the profile that is shown in Figure 8.

In practice, a burst is terminated well before  $V_{cs}$  rises to be approximately the same as  $V_r$ . In fact, if the rise in  $V_{cs}$  is limited to <10% of  $V_r$ , the linearity can be made acceptable for most applications. For simple limit sensing applications,  $V_{cs}$  can be permitted to rise higher, at the expense of increasingly degraded signal-to-noise ratios in the threshold comparison function.

The charge transfer burst can be terminated after a fixed or after a variable number of cycles. If a fixed number is used, the measurement circuit 170 should be capable of representing continuous signals much as in the fashion of an ADC or an analogue amplifier. If a variable burst length is used, a simple comparator with a fixed reference can be employed for the measurement circuit 170, and the length of the burst required is that at which  $V_{cs}$  has built up to a level where it equals the comparison voltage. The burst can continue beyond the required number, but the extra charge transfer cycles are superfluous. A count of the charge transfer cycles required to achieve the comparison voltage is the output result, and for all practical purposes is indistinguishable from an ADC result. Such a result may be obtained by repeating the switching sequence of Figure 6, including a number of loop cycles, in order to periodically check for the presence of a user (e.g. once per second).

Note that in Figure 5 the measurement circuit 170 is connected to the (+), distal, side of  $C_s$ , and the reading is taken when  $S_2$  is closed. Although the (+) side of  $C_s$  is the most convenient measurement point for a ground-referenced signal, it is also possible to measure  $V_{cs}$  on the (-), proximal, side of  $C_s$  by holding  $S_1$  closed instead of  $S_2$ . The reading is then  $V_r$ -referenced instead of ground referenced, which those skilled in the art will recognise as being generally inferior but still possible. In either case, the measurement being made is the *de facto* value of  $V_{cs}$ . Whether the reading is made with respect to ground or  $V_r$  is irrelevant to the invention, what is important is the differential voltage across  $C_s$ .

Although Figure 5 describes the use of a measurement circuit 170, those skilled in the art will realise that this is only one way of putting the invention into effect and that use

of such a measurement circuit is not essential in order to implement alternative embodiments of the invention.

Various optional improvements can be made to the charge transfer capacitance measurement circuit 155 by incorporating additional post-acquisition algorithms into  
5 the processing capability of the signal processor 162. Examples are:

1. A drift compensation mode, in which the circuit 155 can continuously adjust its threshold in accordance with slow changes that affect signal strength. These changes may include temperature fluctuations, moisture build-up, or mechanical creep, etc. This can be accomplished by altering one or more reference level slowly at a slew-rate  
10 limited rate when no detection is being sensed.

2. Incorporation of hysteresis, in which in order to prevent 'contact bounce' the circuit 155 can incorporate detection threshold hysteresis so that the initiation detection level is different, i.e. higher, than the non-detection level, thus requiring the signal to transit through a lower signal level than the threshold level before a 'no detect'  
15 state is entered.

3. Incorporation of a consensus filtering function into the charge transfer capacitance measurement circuit 155. This feature can be provided by one or more comparators acting to compare the measured capacitance value to a predetermined threshold value. It can also be provided by the signal processor 162 sequentially  
20 comparing the measured capacitance value to a threshold value multiple times. A poll of the results is obtained and the consensus as to whether the measured capacitance value is above or below the threshold value is accepted as the final result. This feature reduces the amount of false triggering of the charge transfer capacitance measurement circuit 155 when detecting the presence or absence of a user, and consequently  
25 improves the reliability of the power management unit 150.

The above numbered optional features may be provided by various algorithms encoded in the signal processor, for example. They are also useful in various combinations and degrees in conjunction with various of the circuits described herein, to provide a more

robust sensing solution that can adapt to a variety of real-world sensing challenges, such as dirt accumulation, the presence of moisture, thermal drift, etc.

Figure 9 schematically shows an apparatus according to another embodiment of the invention. The apparatus is a portable music player and comprises a headset 180 which  
5 includes a flexible lead 202 which allows it to be connected to a base unit 182. The apparatus is configured so that playback of an audio signal is automatically paused when a user removes the headset and automatically restarted when a user re-dons the headset.

The headset in this example is a stereo headset and comprises two audio speakers (not  
10 shown) located within respective first 186 and second 188 ear-piece housings. The ear-piece housings 186, 188 are designed to be worn in a user's ear so that the user can hear audio from the speakers. Within the first ear-piece housing 186 is a sensing element in the form of an electrically conducting sense plate 196. The sense plate in this example is a metal ring located adjacent an internal surface of the ear-piece  
15 housing 186. The audio speakers in the ear-piece housings are connected to the base unit 182 via wiring within flexible lead 202 and removable jack plug 200 using generally conventional techniques. However, the flexible lead 202 and jack plug 200 are also configured to establish an electrical connection between the sense plate 196 and the base unit 182 via sense plate connector wire 197.

20 The base unit 182 comprises a housing 192, user accessible control buttons 194 for allowing a user to provide inputs to govern aspects of the operation of the apparatus, control circuitry (also referred to as controller) 204, capacitance measurement circuitry 205 and an audio signal generator 190. In this case the base unit 182 is a hard-disk based audio player and the audio generator 190 comprises a hard-disk 206 for storing  
25 audio files and associated drive and read circuitry 208 and amplifier circuitry 210. The amplifier circuitry supplies signals to the speakers in the ear-piece housings via the wiring in the jack plug 200 and flexible lead 202 to allow the audio files to be played to a user.

In use, a user inserts the ear-pieces 186, 188 of the headset 180 into his respective ears and, using the control buttons 194, instructs the base unit 182 to play a desired audio track to be supplied to the speakers in the ear-pieces. This is achieved in a substantially conventional manner. I.e., the control circuitry 204 responds to inputs from the control  
5 buttons to configure the hard-disk drive 206 and read circuitry 208 appropriately to play back the desired audio track through the amplifier circuitry 210, to the speakers via jack plug 200 and flexible lead 202.

The sense plate 196 is connected to the capacitance measurement circuit via sense plate connector wire 197. During operation, the capacitance measurement circuitry  
10 monitors the capacitance of the sense plate 196, e.g. to a system ground or other reference potential. This can be done using any known capacitance measurement technique. For example, the capacitance measurement circuitry 205 could be based on charge transfer (as described above), measuring the time constant of an RC circuit including the sense plate, or other techniques, such as those based on relaxation  
15 oscillators, phase shift measurements, phase locked loop circuitry, capacitive divider circuitry, and so on, as are known in the art. The capacitance measurement circuitry may be configured to continually monitor the capacitance of the sense plate 196, or to take readings less often, for example once every five seconds or so.

The capacitance measurement circuitry 205 is configured to supply a capacitance  
20 measurement signal representing the measured capacitance to the control circuitry 204. On receipt of the capacitance measurement signal, the control circuitry compares it with a stored threshold level  $C_{th}$  which relates to the capacitance of the sense plate as measured when the headset is not being worn. If the measured capacitance is less than the threshold level it is assumed that the headset is not being worn. If, on the other  
25 hand, the measured capacitance is greater than the threshold level, it is assumed that the head set is being worn on the basis that, as described above, the presence of the user has increased the measured capacitance of the sense plate. Thus the threshold corresponds to the capacitance of the sense plate as measured when the headset is not  
30 being worn plus a margin to account for noise and variations in measured capacitance not associated with the presence of a user. If an average measured capacitance of  $C_{no}$  is expected when the headset is not being worn, and an average measured capacitance of

$C_{yes}$  is expected when the headset is being worn, the threshold may, for example, be set midway between  $C_{no}$  and  $C_{yes}$ .

Thus depending on whether the measured capacitance exceeds the threshold level, the controller can determine whether or not the headset is being worn and activate or disable functions of the apparatus as appropriate (i.e. in accordance with how it has been programmed to operate). In this case, if the measured capacitance is less than the threshold level  $C_{th}$  so that it is determined the headset is not being worn, the controller instructs the drive and read circuitry in the audio generator to pause playback.

The operation of the apparatus may be controlled in stages depending on the duration over which the capacitance is measured to be less than the threshold. For example, during the initial pause in playback, the apparatus may continue to be fully powered, with the hard disk continuing to spin, and so on. However, if after a given period of time, for example, 30 seconds, the measured capacitance is still less than the threshold level  $C_{th}$ , the control circuitry may instruct the read and drive circuitry to stop the hard-disk from spinning, e.g., to reduce wear. If after another period of time, for example, another 30 seconds, the measured capacitance remains less than the threshold level  $C_{th}$ , the control circuitry may then instruct the read and drive circuitry and the power amplifier to enter a power saving mode. After yet a further period of time, for example a further minute or two, if the measured capacitance still remains less than the threshold level  $C_{th}$ , the controller may be configured to fully power down the apparatus on the assumption that the user has permanently stopped listening to it.

If at any stage the measured capacitance rises above the threshold level  $C_{th}$ , the controller determines that a user has re-donned the headset, and playback continues from the point at which it was initially paused. Thus the user is provided with continued playback of an audio track without requiring him to control the apparatus himself.

For ease of explanation, the control circuitry 204, the capacitance measurement circuitry 205 and the drive and read and amplifier circuitry in the audio generator 190 are shown as discrete elements in Figure 9. However, it will be understood that the

functionality of some or all of these circuit elements could be provided by a single integrated circuit. For example, an application specific integrated circuit (ASIC), or a suitably programmed micro-processor could be used. Thus, the division of the above described circuitry functions among integrated circuit components is not significant.

5 For example, the comparison between an analogue representation of the measured capacitance and a threshold level may occur within the capacitance measurement circuitry, with the capacitance measurement circuitry then supplying a binary signal to the control circuitry to indicate whether or not the capacitance exceeds a threshold.

10 Furthermore, it will be appreciated that rather than rely on a threshold level based on an absolute measure of capacitance, the control circuitry may be configured to determine when a user puts on or removes the headset based on changes in measured capacitance. This has the advantage of accommodating drifts in the measurement, e.g. associated with changes in environmental conditions. For example a significant increase in measured capacitance from one measurement to the next (or occurring over  
15 a given time period such as a few seconds, depending on the rate at which measurements are made) would be associated with a user putting on the headset. Conversely, a significant decrease in measured capacitance from one measurement to the next (or over a given time period) would be associated with a user removing the headset. A significant increase/decrease might be deemed to be a change of 50% or  
20 more of the expected difference in measured capacitance between the headset being worn and not worn, for example.

It will also be appreciated that the same techniques can be applied to many other apparatuses. For example, rather than the base unit being a hard-disk based audio player, the apparatus might be a CD player, an audio cassette player, a radio, a DVD  
25 player, a mobile telephone, a solid state based audio player, or any other apparatus that may be associated with providing an audio signal to a headset.

Furthermore, in some embodiments the headset itself may include all of the necessary circuitry such that no separate base unit is required. This is likely to be impractical for some apparatuses, for example CD players, but may be useful for other devices, such  
30 as solid state music players, mobile phone headsets and so on. In some cases, a base

unit may be used, but aspects of the above described circuitry nonetheless be located in the headset. For example, the capacitance measurement circuitry may be located in the headset if there is a concern that the lead to the sense plate would cause too much pick-up for reliable capacitance measurement.

- 5 What is more, in addition to (or instead of) pausing the playback, the invention can be used to control many other functions of an apparatus. For example, the control circuitry may be configured to automatically route audio signals to an external amplifier driving conventional (i.e. not headset) box speakers when the headset is removed. In another example, the control circuitry may be configured to inhibit  
10 response to user inputs depending on whether the headset is being worn. For example, if the headset is not being worn, a button for switching on the apparatus may be inhibited to prevent accidental activation when in a user's pocket or bag. Alternatively, some control buttons, e.g. an increase volume button, may be inhibited when the headset is being worn to prevent accidentally increasing volume to an uncomfortable  
15 level.

- The headset need not be stereo, but could be monaural. Where it is stereo, sense plates could be incorporated in the headset in association with both of a user's ears, if desired. This could allow an apparatus to respond to one or other (or both) ear-piece housings from being removed from a user's head. For example, the apparatus might  
20 pause if any one ear-piece is removed, or only if both are removed. Furthermore, the function to be controlled could depend on which ear-piece (speaker housing) is removed. For example, if a left-ear ear-piece is removed, the audio signal to the speaker in that ear-piece could be stopped while the other was maintained.

- It will be understood that the communication (both of audio signals and capacitance  
25 measurement related signals) between the headset and the base unit (in embodiments where there is one) could be established wirelessly rather than through a flexible lead and jack plug as shown in Figure 9. For example, any of the communications protocols described above could be used.

Figures 10A and 10B are schematic diagrams of an apparatus used to describe a further embodiment of the invention.

Figure 10A shows a wireless ear-mounted single-ear headset 300 of the kind offered currently as Bluetooth™ transceivers. These are widely used with mobile telephones,  
5 home-use cordless telephones connected to landlines or internet telephony connections as well as with other equipment, for example software applications running on a personal computer. The headset 300 has a housing 301 which includes: an earclip 293 for fitting the device over a user's ear; a loudspeaker 290 for aural communication with a user's ear; and a microphone 295 for receiving speech signals from the user.

10 Within the housing 301 proximate the ear clip 293 there is a sensing element in the form of an electrically conducting sense plate 296. The sense plate in this example is a metal ring located adjacent an internal surface of the ear-piece housing so as to be close to the user's skin. The sense plate 296 supplies a capacitive signal to capacitance measurement circuitry 305 which in turn supplies a user presence signal to control  
15 circuitry 304 which is connected to the device's wireless transceiver 297 as well as to the audio transmitter and receiver elements of the device, namely the audio signal generator 290 and microphone 295.

During operation, the capacitance measurement circuitry 305 monitors the capacitance of the sense plate 296, e.g. to a system ground or other reference potential. This can be  
20 done using any known capacitance measurement technique, as mentioned above with reference to the example of Figure 9. The example of Figure 9 is also referred to in respect of further details of the configuration of the device including the use of thresholds.

A concrete example of the use of the wireless headset device of Figure 10A is  
25 described in conjunction with Figure 10B.

Figure 10B shows schematically a mobile phone or cell phone 310. (This could equally well be a cordless landline phone or internet telephony phone.) The phone 310 has a housing 311. On one side a display 314 and keypad 316 are evident. The display or keypad, or both, may have an integral two-dimensional capacitive touch sensor, for



example for text messaging input of Chinese, Japanese, Korean or other language characters. The phone 310 further includes a wireless transceiver 320 for communicating with peripheral devices, such as Bluetooth™ devices. An antenna 318 for transmitting and receiving signals to and from a mobile phone base station is also  
5 illustrated. The phone 310 also includes a loudspeaker 312 for transmitting speech signal to a user's ear and a microphone 313 for receiving speech signals from a user.

Use of the headset of Figure 10A in conjunction with the phone of Figure 10B is now described.

If a communication channel is established between the headset and the phone, then the  
10 audio transmission and reception (loudspeaker and microphone) is switched between the headset and the phone dependent on the user presence signal in the headset. If the user presence signal indicates the headset is being worn, then the audio circuits of the headset are activated and those of the phone deactivated. Conversely, if the user presence signal indicates the headset is not being worn, then the audio circuits of the  
15 headset are deactivated and those of the phone activated. This can provide savings in power consumption. It can also suppress feedback interference that might otherwise occur. Moreover, it can divert the phone's ring tone to the headset if the headset is being worn, and suppress the ring tone from the phone. This mode of operation may be useful in an environment where it is not permitted, or impolite, to allow mobile phone  
20 ring tones, such as an auditorium, restaurant or train. If the user presence signal indicates the headset is being worn, further power consuming circuits of the phone may be deactivated also, either by switching them to a lower power standby mode or more fully powering down. For example, the display backlight could be switched off, or sensing circuitry of a two-dimensional capacitive touch sensor array associated with  
25 the display or keypad could be powered down.

It will be appreciated the headset may operate similarly with a plethora of other devices in addition to the phone example just described.

While the invention is susceptible to various modifications and alternative forms, specific embodiments are shown by way of example in the drawings and are herein described in detail. Accordingly, the skilled man will be aware that many different embodiments of the invention are possible. It should thus be understood that the drawings and corresponding detailed description are not intended to limit the invention to the particular form disclosed, but on the contrary, the invention is to cover all modifications, equivalents and alternatives falling within the spirit and scope of the present invention as defined by the appended claims.

For example, the skilled man would be aware that capacitive sensing may entail use of a sensor circuit for measuring the absolute or relative capacitance of a two-leaded capacitor or of a free-space sense plate, and for providing as an output, a measurement of the capacitance in any usable form. For example, a device only capable of generating a single-bit thresholded "detect" output would still be considered a sensor circuit for the purposes of this disclosure.

The skilled man would also be aware that a capacitive sensor may be located remotely from a headset. For example, a capacitive sensor may be provided on an electronic device, such as a mobile telephone, to which the headset is operably coupled.

In addition, the skilled man would be aware that various of the switches described herein may be implemented using an electronically controlled switch, such as, for example, by way of a bipolar or field effect transistor, a relay, an opto-electronic device, or any functionally similar circuit. He would also be aware that a controller or control circuit may comprise a circuit or system capable of generating digital control signals. Such a controller or control circuit may control a capacitance measurement circuit sensor (including control of switching elements therein) and the measurement circuit, and may generate a decision output if required. Such controllers or control circuits may comprise digital logic means such as a programmable logic array or a microprocessor, for example.

Those skilled in the art will also be aware that headsets according to the present invention need not necessarily be cordless devices that incorporate receivers and

transmitters, or merely receivers, whether they be Bluetooth™ enabled or otherwise. Moreover, they will also be aware that various embodiments of the invention may be wearable by a user in proximity to only a single ear, and not require the use of stereo loudspeakers.

References

1. GB-A-1,483,829
2. US-5,678,202
3. US-B1-6,356,644
- 5 4. JP2000278785 A
5. US-B1-6,466,036

**CLAIMS:**

1. An apparatus comprising:  
a headset including a sensing element;  
5 a capacitance measurement circuit operable to measure the capacitance of the sensing element; and  
a control circuit operable to determine whether a user is wearing the headset based on a measurement of the capacitance of the sensing element, and to control a function of the apparatus according to whether the headset is being worn.  
10
2. The apparatus of claim 1, wherein the capacitance measurement circuit includes a sample capacitor and is further operable to transfer charge from the sensing element to the sample capacitor to generate an electric potential at the sample capacitor for measuring.  
15
3. The apparatus of claim 2, comprising at least one switch operable to transfer a burst of charge packets sequentially from the sensing element to the sample capacitor prior to a measurement of the electric potential being made.
- 20 4. The apparatus of claim 1, 2 or 3, wherein the control circuit is operable to determine whether a user is wearing the headset by comparing a measured capacitance of the sensing element to at least one predetermined threshold value.
5. The apparatus of any of claims 1 to 4, wherein the sensing element comprises  
25 an electrode that is electrically isolated from the user when the headset is being worn.
6. The apparatus of any of claims 1 to 5, wherein the capacitance measurement circuit is internal to the headset.
- 30 7. The apparatus of claim 6, wherein the control circuit is internal to the headset.

8. The apparatus of claim 7, wherein the function to be controlled is provided by a circuit element which is internal to the headset.
9. The apparatus of any of claims 1 to 8, wherein the function to be controlled is provided by a circuit element which is external to the headset.
10. The apparatus of claim 9, wherein the control circuit is external to the headset.
11. The apparatus of claim 10, wherein the capacitance measurement circuit is external to the headset.
12. The apparatus of any of claims 1 to 11, wherein the function to be controlled is a power saving function.
13. The apparatus of any of claims 1 to 11, further comprising an audio amplifier for supplying audio signals to speakers in the headset, and wherein the function to be controlled is the activation of the audio amplifier.
14. The apparatus of any of claims 1 to 11, further comprising a wireless communications transceiver, and wherein the function to be controlled is the activation of the wireless communications transceiver.
15. The apparatus of any of claims 1 to 11, further comprising an audio generator for outputting an audio signal, and wherein the function to be controlled is the outputting of an audio signal by the audio generator.
16. The apparatus of any of claims 1 to 11, further comprising input buttons for supplying operating signals to the control circuit to allow a user to govern the operation of the apparatus, and the function to be controlled is the inhibition of signals from the input buttons.

17. A method of operating an apparatus comprising a headset, the method comprising:  
measuring the capacitance of a sensing element in the headset;  
determining from the measured capacitance whether a user is wearing the  
5 headset; and  
controlling a function of the apparatus in response to determining whether the headset is being worn.
18. The method of claim 17, wherein measuring the capacitance of the sensing  
10 element includes:  
transferring charge from the sensing element to a sample capacitor;  
measuring the electric potential at the sample capacitor; and  
determining the capacitance of the sensing element from the measured electric  
potential of the sample capacitor.  
15
19. The method of claim 18, wherein transferring charge from the sensing element to a sample capacitor comprises transferring a burst of charge packets in sequence from the sensing element to a sample capacitor.
20. The method of claim 17, 18 or 19, wherein determining whether a user is wearing the headset or not comprises comparing the measured capacitance of the sensing element to at least one predetermined threshold value in order to determine whether the capacitance of the sensing element has been changed due to the proximity of a user.  
25
21. The method of claim 20, comprising adjusting one or more of the threshold values in response to changes in operating conditions.
22. The method of any of claims 17 to 21, wherein the controlling a function of the  
30 apparatus comprises controlling whether or not the apparatus is in a power saving mode.

23. The method of any of claims 17 to 21, wherein the controlling a function of the apparatus comprises controlling whether or not wireless communications transceiver is activated.
- 5 24. The method of any of claims 17 to 21, wherein the controlling a function of the apparatus comprises controlling whether or not an audio signal generator is activated.
25. The method of any of claims 17 to 21, wherein the controlling a function of the apparatus comprises controlling whether or not user inputs for governing the operation  
10 of the apparatus are inhibited.
26. A headset comprising:  
at least one circuit element;  
a capacitive sensor operable to provide a capacitance measurement signal; and  
15 a sensing circuit operable to generate a user presence signal responsive to the capacitance measurement signal indicating whether the headset is being worn and operable to control the at least one circuit element dependent on said user presence signal, or to output an external output signal that is dependent on said user presence signal for receipt by another device to which the headset is connected.  
20
27. The headset of claim 26, wherein the sensing circuit includes a sample capacitor and is further operable to transfer charge from the capacitive sensor to the sample capacitor to generate an electric potential at the sample capacitor for measuring.  
25
28. The headset of claim 27, comprising at least one switch operable to transfer a burst of charge packets sequentially from the capacitive sensor to the sample capacitor prior to any measurement of the electric potential being made.
- 30 29. The headset of claim 26, 27 or 28, wherein the sensing circuit comprises a consensus filter for generating the user presence signal.



30. The headset of any of claims 26 to 29, wherein the sensing circuit is further operable automatically to perform a self-calibration operation.
31. The headset of any of claims 26 to 30, wherein the capacitive sensor comprises  
5 an electrode that is electrically isolated from the user when the headset is being worn.
32. The headset of any of claims 26 to 31, wherein at least one of the circuit elements comprises a wireless communications transceiver.
- 10 33. The headset of any of claims 26 to 32, further comprising a power management unit, of which the sensing circuit is a part, and wherein the power management unit is operable to reduce power consumption of the at least one circuit element dependent on said user presence signal, thereby to reduce power consumption of the headset.
- 15 34. A method of operating a headset in order to reduce power consumption, the method comprising:  
measuring the capacitance of a capacitive sensor;  
determining from the measured capacitance whether a user is present or not;  
and  
20 powering down one or more circuit elements in the headset in response to determining that no user is present in order to reduce the power consumption of the headset.
- 25 35. The method of claim 34, wherein measuring the capacitance of the capacitive sensor includes:  
transferring charge from the capacitive sensor to a sample capacitor;  
measuring the electric potential at the sample capacitor; and  
determining the capacitance of the capacitive sensor from the measured electric  
30 potential of the sample capacitor.

30

36. The method of claim 35, wherein transferring charge from the capacitive sensor to a sample capacitor comprises transferring a burst of charge packets in sequence from the capacitive sensor to a sample capacitor.
- 5 37. The method of claim 34, 35 or 36, wherein determining whether a user is present or not comprises comparing the measured capacitance of the capacitive sensor to one or more predetermined threshold values in order to determine whether the capacitance of the capacitive sensor has been changed by the proximity of the user.
- 10 38. The method of claim 37, comprising adjusting one or more of the threshold values in response to changes in operating conditions.
39. A method of operating a headset, the method comprising:  
measuring the capacitance of a capacitive sensor;  
15 determining from the measured capacitance whether a user is present or not;  
and  
controlling a function of the headset, or outputting an external output signal that can be received by another device to which the headset is connected, in response to determining whether the user is present or not.
- 20 40. The method of claim 39, wherein measuring the capacitance of the capacitive sensor includes:  
transferring charge from the capacitive sensor to a sample capacitor;  
measuring the electric potential at the sample capacitor; and  
25 determining the capacitance of the capacitive sensor from the measured electric potential of the sample capacitor.
41. The method of claim 40, wherein transferring charge from the capacitive sensor to a sample capacitor comprises transferring a burst of charge packets in  
30 sequence from the capacitive sensor to a sample capacitor.

42. The method of claim 39, 40 or 41, wherein determining whether a user is present or not comprises comparing the measured capacitance of the capacitive sensor to one or more predetermined threshold values in order to determine whether the capacitance of the capacitive sensor has been changed by the proximity of the user.
- 5
43. The method of claim 42, comprising adjusting one or more of the threshold values in response to changes in operating conditions.
44. The method of any of claims 39 to 43, wherein said device to which the  
10 headset is connected is connected thereto wirelessly.
45. The method of any of claims 39 to 43, wherein said device to which the headset is connected is wired thereto.
- 15
46. A headset substantially as hereinbefore described with reference to the accompanying drawings.
47. A method of operating an apparatus comprising a headset substantially as hereinbefore described with reference to the accompanying drawings.



For innovation

30

**Application No:** GB0618960.9

**Examiner:** Simon Colcombe

**Claims searched:** 1-47

**Date of search:** 22 February 2007

**Patents Act 1977: Search Report under Section 17**

**Documents considered to be relevant:**

Category	Relevant to claims	Identity of document and passage or figure of particular relevance
X,P	1, 17, 26, 34, 39 at least	WO2005/099105 A1 (SONY ERICSSON) Whole document
X,Y	X:1, 17, 26, 39; Y:34, at least	WO03/103175 A1 (MOTOROLA) Whole document
X,Y	X:1, 17, 26, 39; Y:34, at least	US2002/0068537 A1 (MOBIGENCE) Whole document
X,Y	X:1, 17, 26, 39; Y:34, at least	GB2357400 A (NOKIA) Whole document
X,Y	X:1, 17, 26, 39; Y:34, at least	EP0564164 A1 (AT&T) Whole document
Y	34 at least	EP1260082 A1 (ERICSSON) Whole document
A	-	US6466036 B1 (PHILIPP)

**Categories:**

X	Document indicating lack of novelty or inventive step	A	Document indicating technological background and/or state of the art.
Y	Document indicating lack of inventive step if combined with one or more other documents of same category.	P	Document published on or after the declared priority date but before the filing date of this invention.
&	Member of the same patent family	E	Patent document published on or after, but with priority date earlier than, the filing date of this application.

**Field of Search:**

**dti** ADTI SERVICE



For Innovation

37

Search of GB, EP, WO & US patent documents classified in the following areas of the UKC<sup>X</sup> :

G1N

Worldwide search of patent documents classified in the following areas of the IPC

H03K; H04R

The following online and other databases have been used in the preparation of this search report

WPI, EPODOC

**dti** ADTI SERVICE

## Electronic Acknowledgement Receipt

<b>EFS ID:</b>	6807847
<b>Application Number:</b>	12179769
<b>International Application Number:</b>	
<b>Confirmation Number:</b>	8745
<b>Title of Invention:</b>	Proximity Sensor
<b>First Named Inventor/Applicant Name:</b>	Harald Philipp
<b>Customer Number:</b>	76287
<b>Filer:</b>	David Ross Cochran/Judy Dent
<b>Filer Authorized By:</b>	David Ross Cochran
<b>Attorney Docket Number:</b>	3050.030US1
<b>Receipt Date:</b>	14-JAN-2010
<b>Filing Date:</b>	25-JUL-2008
<b>Time Stamp:</b>	10:06:01
<b>Application Type:</b>	Utility under 35 USC 111(a)

### Payment information:

Submitted with Payment	no
------------------------	----

### File Listing:

Document Number	Document Description	File Name	File Size(Bytes)/ Message Digest	Multi Part /.zip	Pages (if appl.)
1		signed_1-14-10_3050_030US1.pdf	144982 57ec1cecdce8b91a2d972764c60e808f27c82d4c	yes	4

Multipart Description/PDF files in .zip description			
Document Description	Start	End	
Miscellaneous Incoming Letter	1	1	
Transmittal Letter	2	3	
Information Disclosure Statement (IDS) Filed (SB/08)	4	4	

**Warnings:**

**Information:**

2	Foreign Reference	001_ep1536314.pdf	714908	no	16
			b85549df45cc644b6a79e99c4a102f3abf74824		

**Warnings:**

**Information:**

3	Foreign Reference	002_gb02431725a1.pdf	1588491	no	47
			fccc03ae67248286fdbc9648c68fb14dd6ef8ec3		

**Warnings:**

**Information:**

<b>Total Files Size (in bytes):</b>			2448381		
-------------------------------------	--	--	---------	--	--

This Acknowledgement Receipt evidences receipt on the noted date by the USPTO of the indicated documents, characterized by the applicant, and including page counts, where applicable. It serves as evidence of receipt similar to a Post Card, as described in MPEP 503.

**New Applications Under 35 U.S.C. 111**

If a new application is being filed and the application includes the necessary components for a filing date (see 37 CFR 1.53(b)-(d) and MPEP 506), a Filing Receipt (37 CFR 1.54) will be issued in due course and the date shown on this Acknowledgement Receipt will establish the filing date of the application.

**National Stage of an International Application under 35 U.S.C. 371**

If a timely submission to enter the national stage of an international application is compliant with the conditions of 35 U.S.C. 371 and other applicable requirements a Form PCT/DO/EO/903 indicating acceptance of the application as a national stage submission under 35 U.S.C. 371 will be issued in addition to the Filing Receipt, in due course.

**New International Application Filed with the USPTO as a Receiving Office**

If a new international application is being filed and the international application includes the necessary components for an international filing date (see PCT Article 11 and MPEP 1810), a Notification of the International Application Number and of the International Filing Date (Form PCT/RO/105) will be issued in due course, subject to prescriptions concerning national security, and the date shown on this Acknowledgement Receipt will establish the international filing date of the application.

IN THE UNITED STATES PATENT AND TRADEMARK OFFICE

Applicant: Harald Philipp et al.

Title: Proximity Sensor

Docket No.: 3050.030US1  
Filed: July 25, 2008  
Examiner: Diego Gutierrez  
Customer No.: 76287

Serial No.: 12/179,769  
Due Date: N/A  
Group Art Unit: Unknown  
Confirmation No.: 8745

Mail Stop Amendment  
Commissioner for Patents  
P.O. Box 1450  
Alexandria, VA 22313-1450

We are transmitting herewith the following attached items (as indicated with an "X"):

Supplemental Information Disclosure Statement (2 pgs.), Form 1449 (1 pg.) Copies of Cited References (2).

**If not provided for in a separate paper filed herewith, please consider this a PETITION FOR EXTENSION OF TIME for sufficient number of months to enter these papers and please charge any additional fees or credit overpayment to Deposit Account No. 19-0743.**

SCHWEGMAN, LUNDBERG & WOESSNER, P.A.  
Customer No.: 76287

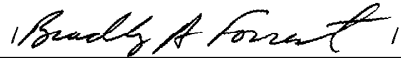
By:   
Bradley A. Forrest  
Reg. No. 30,837

CERTIFICATE UNDER 37 CFR 1.8: The undersigned hereby certifies that this correspondence is being filed using the USPTO's electronic filing system EFS-Web, and is addressed to: Mail Stop Amendment Commissioner for Patents, P.O. Box 1450, Alexandria, VA 22313-1450 on this 14th day of January, 2010.

Judy Dent  
Name

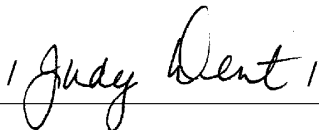
  
Signature



**S/N 12/179,769**

**PATENT**

**IN THE UNITED STATES PATENT AND TRADEMARK OFFICE**

Applicants:	Harald Philipp et al.	Examiner:	Diego Gutierrez
Serial No.:	12/179,769	Group Art Unit:	Unknown
Filed:	July 25, 2008	Docket:	3050.030US1
Customer No.:	76287	Confirmation No.:	8745
Title:	Proximity Sensor		

---

**SUPPLEMENTAL INFORMATION DISCLOSURE STATEMENT**

MS Amendment  
Commissioner for Patents  
P.O. Box 1450  
Alexandria, VA 22313-1450

In compliance with the duty imposed by 37 C.F.R. § 1.56, and in accordance with 37 C.F.R. §§ 1.97 *et. seq.*, the enclosed materials are brought to the attention of the Examiner for consideration in connection with the above-identified patent application. Applicants respectfully request that this Information Disclosure Statement be entered and the documents listed on the attached PTO 1449 Form be considered by the Examiner and made of record. Pursuant to the provisions of MPEP 609, Applicants request that a copy of the PTO 1449 Form, initialed as being considered by the Examiner, be returned to the Applicants with the next official communication.

Pursuant to 37 C.F.R. § 1.97(b), it is believed that no fee or statement is required with the Information Disclosure Statement. However, if an Office Action on the merits has been mailed, the Commissioner is hereby authorized to charge the required fees to Deposit Account No. 19-0743 in order to have this Information Disclosure Statement considered.

Pursuant to 37 C.F.R. § 1.98(a)(2), copies of cited U.S. Patents and Published Applications, and Non-Published Applications identifiable by USPTO Serial Number, are no longer required to be provided to the Office. Applicants acknowledge the requirement to submit copies of foreign patent documents and non-patent literature in accordance with 37 C.F.R § 1.98(a)(2).

The Examiner is invited to contact the Applicants' Representative at the telephone number indicated if there are any questions regarding this communication.

Respectfully submitted,

SCHWEGMAN, LUNDBERG & WOESSNER, P.A.  
P.O. Box 2938  
Minneapolis, MN 55402  
(612) 373-6972

Date 13 January 2010 By *Bradley A. Forrest*  
Bradley A. Forrest  
Reg. No. 30,837

BAF:jld

CERTIFICATE UNDER 37 CFR 1.8: The undersigned hereby certifies that this correspondence is being filed using the USPTO's electronic filing system EFS-Web, and is addressed to: MS Amendment, Commissioner for Patents, P.O. Box 1450, Alexandria, VA 22313-1450 on this 14th day of January, 2010.

Judy Dent  
Name

*Judy Dent*  
Signature



UNITED STATES PATENT AND TRADEMARK OFFICE

UNITED STATES DEPARTMENT OF COMMERCE
United States Patent and Trademark Office
Address: COMMISSIONER FOR PATENTS
P.O. Box 1450
Alexandria, Virginia 22313-1450
www.uspto.gov

Table with 5 columns: APPLICATION NO., FILING DATE, FIRST NAMED INVENTOR, ATTORNEY DOCKET NO., CONFIRMATION NO.
Row 1: 12/179,769, 07/25/2008, Harald Philipp, 3050.030US1, 8745
Row 2: 76287, 7590, 10/04/2010, SCHWEGMAN, LUNDBERG & WOESSNER / ATMEL, P.O. BOX 2938, MINNEAPOLIS, MN 55402
Row 3: EXAMINER NGUYEN, HOAI AN D
Row 4: ART UNIT 2831, PAPER NUMBER
Row 5: NOTIFICATION DATE 10/04/2010, DELIVERY MODE ELECTRONIC

Please find below and/or attached an Office communication concerning this application or proceeding.

The time period for reply, if any, is set in the attached communication.

Notice of the Office communication was sent electronically on above-indicated "Notification Date" to the following e-mail address(es):

uspto@slwip.com
request@slwip.com

<b>Office Action Summary</b>	<b>Application No.</b> 12/179,769	<b>Applicant(s)</b> PHILIPP ET AL.	
	<b>Examiner</b> HOAI-AN D. NGUYEN	<b>Art Unit</b> 2831	

**-- The MAILING DATE of this communication appears on the cover sheet with the correspondence address --**

**Period for Reply**

A SHORTENED STATUTORY PERIOD FOR REPLY IS SET TO EXPIRE 3 MONTH(S) OR THIRTY (30) DAYS, WHICHEVER IS LONGER, FROM THE MAILING DATE OF THIS COMMUNICATION.

- Extensions of time may be available under the provisions of 37 CFR 1.136(a). In no event, however, may a reply be timely filed after SIX (6) MONTHS from the mailing date of this communication.
- If NO period for reply is specified above, the maximum statutory period will apply and will expire SIX (6) MONTHS from the mailing date of this communication.
- Failure to reply within the set or extended period for reply will, by statute, cause the application to become ABANDONED (35 U.S.C. § 133). Any reply received by the Office later than three months after the mailing date of this communication, even if timely filed, may reduce any earned patent term adjustment. See 37 CFR 1.704(b).

**Status**

- 1)  Responsive to communication(s) filed on \_\_\_\_.
- 2a)  This action is **FINAL**.                      2b)  This action is non-final.
- 3)  Since this application is in condition for allowance except for formal matters, prosecution as to the merits is closed in accordance with the practice under *Ex parte Quayle*, 1935 C.D. 11, 453 O.G. 213.

**Disposition of Claims**

- 4)  Claim(s) 1-23 is/are pending in the application.  
4a) Of the above claim(s) \_\_\_\_ is/are withdrawn from consideration.
- 5)  Claim(s) \_\_\_\_ is/are allowed.
- 6)  Claim(s) 1-3, 5, 6 and 8-23 is/are rejected.
- 7)  Claim(s) 4 and 7 is/are objected to.
- 8)  Claim(s) \_\_\_\_ are subject to restriction and/or election requirement.

**Application Papers**

- 9)  The specification is objected to by the Examiner.
- 10)  The drawing(s) filed on 31 August 2008 is/are: a)  accepted or b)  objected to by the Examiner.  
Applicant may not request that any objection to the drawing(s) be held in abeyance. See 37 CFR 1.85(a).  
Replacement drawing sheet(s) including the correction is required if the drawing(s) is objected to. See 37 CFR 1.121(d).
- 11)  The oath or declaration is objected to by the Examiner. Note the attached Office Action or form PTO-152.

**Priority under 35 U.S.C. § 119**

- 12)  Acknowledgment is made of a claim for foreign priority under 35 U.S.C. § 119(a)-(d) or (f).  
a)  All    b)  Some \*    c)  None of:  
1.  Certified copies of the priority documents have been received.  
2.  Certified copies of the priority documents have been received in Application No. \_\_\_\_.  
3.  Copies of the certified copies of the priority documents have been received in this National Stage application from the International Bureau (PCT Rule 17.2(a)).
- \* See the attached detailed Office action for a list of the certified copies not received.

**Attachment(s)**

- |  |   |
|--|---|
| 1) <input checked="" type="checkbox"/> Notice of References Cited (PTO-892)  | 4) <input type="checkbox"/> Interview Summary (PTO-413)<br>Paper No(s)/Mail Date. ____. |
| 2) <input type="checkbox"/> Notice of Draftsperson's Patent Drawing Review (PTO-948)   | 5) <input type="checkbox"/> Notice of Informal Patent Application                       |
| 3) <input checked="" type="checkbox"/> Information Disclosure Statement(s) (PTO/SB/08)<br>Paper No(s)/Mail Date <u>7/25/08;11/28/08;1/14/10.</u> | 6) <input type="checkbox"/> Other: ____.  |

## DETAILED ACTION

### *Specification*

1. Applicant is reminded of the proper language and format for an abstract of the disclosure.

The abstract should be in narrative form and generally limited to a single paragraph on a separate sheet within the range of 50 to 150 words. It is important that the abstract not exceed 150 words in length since the space provided for the abstract on the computer tape used by the printer is limited. The form and legal phraseology often used in patent claims, such as "means" and "said," should be avoided. The abstract should describe the disclosure sufficiently to assist readers in deciding whether there is a need for consulting the full patent text for details.

The language should be clear and concise and should not repeat information given in the title. It should avoid using phrases which can be implied, such as, "The disclosure concerns," "The disclosure defined by this invention," "The disclosure describes," etc.

2. The abstract of the disclosure is objected to because it contains a legal phraseology, such as "comprises" in line 3. Correction is required. See MPEP § 608.01(b).

### *Claim Objections*

3. Claims 1, 14 and 22 are objected to because of the following informalities:

With regard to claim 1, all appearances of "an object" in lines 5 and 8 should be replaced with -- the object--.

With regard to claim 14, "an" in line 1 should be replaced with -- the --.

With regard to claim 22, "an" in line 4 should be replaced with -- the --.

Appropriate correction is required.

***Claim Rejections - 35 USC § 102***

4. The following is a quotation of the appropriate paragraphs of 35 U.S.C. 102 that form the basis for the rejections under this section made in this Office action:

A person shall be entitled to a patent unless –

(b) the invention was patented or described in a printed publication in this or a foreign country or in public use or on sale in this country, more than one year prior to the date of application for patent in the United States.

5. Claims 1-3, 5, 6, 8-18 and 21-23 are rejected under 35 U.S.C. 102(b) as being anticipated by Philipp (US 2007/0076897 A1).

Philipp teaches a headsets and headset power management comprising:

With regard to claims 1, 21 and 22, a sensor (FIG. 4, power management unit 150) for determining the presence of an object (user) comprising a sensing element (FIG. 4, sense plate 160); a capacitance measurement circuit (FIG. 4, charge sensing circuit 152) operable to measure the capacitance of the sensing element; and a control circuit (FIG. 4, signal processor 162) operable to determine whether an object (FIG. 4, sensor-device 10) is in proximity with the sensor based on a measurement of the capacitance of the sensing element, the control circuit further being operable to provide an output signal (FIG. 4, sensor-device 10) to control a function of an apparatus when it is determined that an object has not been in proximity with the sensor for a predetermined time duration (Paragraphs, [0010]-[0037], [0060]-[0062], [0095] and [0096]).

With regard to claim 2, the control circuit (FIG. 9 in view of FIG. 4, capacitance measurement circuitry 205 and control circuitry 204) is configured so that the predetermined

Art Unit: 2831

time duration is selectable from a number of different predefined time durations (to continually monitor the capacitance of the sense plate 196, or to take readings less often, for example once every five seconds or so) (Paragraphs, [0092]-[0093]).

With regard to claim 5, the control circuit (FIG. 9 in view of FIG. 4, capacitance measurement circuitry 205 and control circuitry 204) includes a time input terminal and the predetermined time duration is selectable from the number of different predefined time durations according to a voltage applied to the time input terminal (Paragraphs, [0090] and [0095]).

With regard to claim 5, the control circuit (FIG. 9 in view of FIG. 4, capacitance measurement circuitry 205 and control circuitry 204) is configured so that the predetermined time duration is programmable by a user to provide a user- selected time duration (Paragraphs, [0092]-[0095]).

With regard to claim 6, a resistor-capacitor (RC) network coupled to the control circuit and wherein the predetermined time duration depends on a time constant of the RC network (Paragraph, [0092]).

With regard to claims 14 and 23, the function of the apparatus controlled by the output signal is a switch-off function (Paragraph, [0095]).

With regard to claim 15, the capacitance measurement circuit (FIG. 4, charge sensing circuit 152) employs bursts of charge-transfer cycles to acquire measurements (Paragraph, [0012]).

With regard to claims 8-13 and 16-18, these claims are directed to an apparatus whose features are recited functionally. However, claims directed to an apparatus must be distinguished from the prior art in terms of structure rather than function alone (See MPEP 2114). The

Art Unit: 2831

controller (signal processor 162 in FIG. 4 or control circuitry 204 in FIG. 9) in combination with the capacitance measurement circuit (charge sensing circuit 152 in FIG. 4 or capacitance measurement circuitry 205 in FIG. 9) is fully capable of performing functions as recited in claims 8-13 and 16-18, respectively (Paragraphs, [0010]-[0037], [0060]-[0062], [0095] and [0096]).

***Claim Rejections - 35 USC § 103***

6. The following is a quotation of 35 U.S.C. 103(a) which forms the basis for all obviousness rejections set forth in this Office action:

(a) A patent may not be obtained though the invention is not identically disclosed or described as set forth in section 102 of this title, if the differences between the subject matter sought to be patented and the prior art are such that the subject matter as a whole would have been obvious at the time the invention was made to a person having ordinary skill in the art to which said subject matter pertains. Patentability shall not be negated by the manner in which the invention was made.

7. Claim 19 is rejected under 35 U.S.C. 103(a) as being unpatentable over Philipp in view of Philipp et al. (US 2007/0062739 A1).

Philipp teaches all that is claimed as discussed in the above rejection of claims 1-3, 5, 6, 8-18 and 21-23, but it does not specifically teach the following feature:

- The capacitance measurement circuit and the control circuit are comprised in a general purpose microcontroller under firmware control.

Philipp et al. teaches a touch sensitive screen comprising:

With regard to claim 19, a capacitance measurement circuit (FIG. 1B, sense unit 8) and a control circuit (FIG. 1B, sensor controller 10) are comprised in a general purpose microcontroller under firmware control (Paragraph [0039]).



Therefore, it would have been obvious to one having ordinary skill in the art at the time the invention was made to modify the headsets and headset power management of Philipp to incorporate the teaching of the capacitance measurement circuit and the control circuit built-in a general purpose microcontroller under firmware control taught by Philipp et al. since such an arrangement is beneficial to provide desirable, exemplary and common choices for a specific configuration of a single integrated circuit chip for a sensor for detecting the presence of an object within a sensing area.

8. Claim 20 is rejected under 35 U.S.C. 103(a) as being unpatentable over Philipp in view of Lee (US 7,091,727 B2).

Philipp teaches all that is claimed as discussed in the above rejection of claims 1-3, 5, 6, 8-18 and 21-23, but it does not specifically teach the following feature:

- The capacitance measurement circuit and the control circuit are comprised within a six-pin integrated circuit chip package.

Lee teaches a method and IC for detecting capacitance variation comprising:

With regard to claim 20, a capacitance measurement circuit and a control circuit are comprised within a six-pin integrated circuit chip package (FIGS. 2 or 10; column 4, lines 43-55).

Therefore, it would have been obvious to one having ordinary skill in the art at the time the invention was made to modify the headsets and headset power management of Philipp to incorporate the teaching of the capacitance measurement circuit and the control circuit built-in a six-pin integrated circuit chip package taught by Lee since such an arrangement is beneficial to provide desirable, exemplary and common choices for a specific configuration of a single

Art Unit: 2831

integrated circuit chip for a sensor for detecting capacitance variation, which can be used for detecting the presence of an object within a sensing area.

*Allowable Subject Matter*

9. Claims 4 and 7 are objected to as being dependent upon a rejected base claim, but would be allowable if rewritten in independent form including all of the limitations of the base claim and any intervening claims.

The following is a statement of reasons for the indication of allowable subject matter:

- The primary reason for the indication of the allowability of claim 4 is the inclusion therein, in combination as currently claimed, of the limitation of the control circuit includes a delay multiplier terminal and is configured so that a selected one of the number of different predefined time durations is multiplied by a multiplication factor according to a voltage applied to the delay multiplier terminal to provide the predetermined time duration. This limitation is found in claim 4 is neither disclosed nor taught by the prior art of record, alone or in combination.
- The primary reason for the indication of the allowability of claim 7 is the inclusion therein, in combination as currently claimed, of the limitation of the control circuit includes a delay multiplier terminal and is configured so that the user-selected time duration is multiplied by a multiplication factor according to a voltage applied to the delay multiplier terminal to provide the predetermined time

Art Unit: 2831

duration. This limitation is found in claim 7 is neither disclosed nor taught by the prior art of record, alone or in combination.

### ***Conclusion***

10. The prior art made of record and not relied upon is considered pertinent to applicant's disclosure. Applicant's attention is invited to the followings whose inventions disclose similar devices.

- Yoshida et al. (US 7,567,088 B2) teaches a foreign object detection apparatus.
- Fujiwara et al. (US 7,714,595 B2) teaches a foreign object detection sensor.
- Tasher et al. (US 7,797,115 B2) teaches a time interval measurement for capacitive detection.
- Ellenz (US 2003/0132763 A1) teaches a capacitance-based sensing device for detecting presence of body part.
- Abe (US 2006/0250142 A1) teaches an electrostatic capacity detection type proximity sensor.

### **CONTACT INFORMATION**

Any inquiry concerning this communication or earlier communications from the examiner should be directed to HOAI-AN D. NGUYEN whose telephone number is (571)272-2170. The examiner can normally be reached on MON-THURS. (7:15 - 5:45).

If attempts to reach the examiner by telephone are unsuccessful, the examiner's supervisor, Melissa J. Koval can be reached on (571)-272-2121. The fax phone number for the organization where this application or proceeding is assigned is 571-273-8300.

Information regarding the status of an application may be obtained from the Patent Application Information Retrieval (PAIR) system. Status information for published applications may be obtained from either Private PAIR or Public PAIR. Status information for unpublished applications is available through Private PAIR only. For more information about the PAIR system, see <http://pair-direct.uspto.gov>. Should you have questions on access to the Private PAIR system, contact the Electronic Business Center (EBC) at 866-217-9197 (toll-free). If you would like assistance from a USPTO Customer Service Representative or access to the automated information system, call 800-786-9199 (IN USA OR CANADA) or 571-272-1000.

Hoai-An D. Nguyen  
Primary Examiner  
Art Unit 2831

/Hoai-An D. Nguyen/  
Primary Examiner, Art Unit 2831

<b>Notice of References Cited</b>	Application/Control No. 12/179,769	Applicant(s)/Patent Under Reexamination PHILIPP ET AL.	
	Examiner HOAI-AN D. NGUYEN	Art Unit 2831	Page 1 of 1

**U.S. PATENT DOCUMENTS**

*	Document Number Country Code-Number-Kind Code	Date MM-YYYY	Name	Classification
*	A US-2003/0132763 A1	07-2003	Ellenz, John David	324/663
*	B US-7,091,727 B2	08-2006	Lee, Sang-Chuel	324/681
*	C US-2006/0250142 A1	11-2006	Abe, Hiroshi	324/663
*	D US-2007/0062739 A1	03-2007	Philipp et al.	178/018.06
*	E US-2007/0076897 A1	04-2007	Philipp, Harald	381/074
*	F US-7,567,088 B2	07-2009	Yoshida et al.	324/663
*	G US-7,714,595 B2	05-2010	Fujiwara et al.	324/663
*	H US-7,797,115 B2	09-2010	Tasher et al.	702/57
*	I US-			
*	J US-			
*	K US-			
*	L US-			
*	M US-			

**FOREIGN PATENT DOCUMENTS**

*	Document Number Country Code-Number-Kind Code	Date MM-YYYY	Country	Name	Classification
*	N				
*	O				
*	P				
*	Q				
*	R				
*	S				
*	T				

**NON-PATENT DOCUMENTS**

*	Include as applicable: Author, Title Date, Publisher, Edition or Volume, Pertinent Pages)
*	U
*	V
*	W
*	X

\*A copy of this reference is not being furnished with this Office action. (See MPEP § 707.05(a).)  
Dates in MM-YYYY format are publication dates. Classifications may be US or foreign.

<b><i>Index of Claims</i></b>  	<b>Application/Control No.</b> 12179769	<b>Applicant(s)/Patent Under Reexamination</b> PHILIPP ET AL.
	<b>Examiner</b> HOAI-AN D NGUYEN	<b>Art Unit</b> 2831

✓	<b>Rejected</b>	-	<b>Cancelled</b>	N	<b>Non-Elected</b>	A	<b>Appeal</b>
=	<b>Allowed</b>	÷	<b>Restricted</b>	I	<b>Interference</b>	O	<b>Objected</b>

Claims renumbered in the same order as presented by applicant
  CPA
  T.D.
  R.1.47

CLAIM		DATE							
Final	Original	09/28/2010							
	1	✓							
	2	✓							
	3	✓							
	4	O							
	5	✓							
	6	✓							
	7	O							
	8	✓							
	9	✓							
	10	✓							
	11	✓							
	12	✓							
	13	✓							
	14	✓							
	15	✓							
	16	✓							
	17	✓							
	18	✓							
	19	✓							
	20	✓							
	21	✓							
	22	✓							
	23	✓							

<b>Search Notes</b> 	<b>Application/Control No.</b>	<b>Applicant(s)/Patent under Reexamination</b>	
	12/179,769	PHILIPP ET AL.	
	<b>Examiner</b>	<b>Art Unit</b>	
	HOAI-AN D. NGUYEN	2831	

SEARCHED			
Class	Subclass	Date	Examiner
324	663	9/27/2010	HADN
324	658	9/27/2010	HADN
324	649	9/27/2010	HADN
324	600	9/27/2010	HADN
702	57	9/28/2010	HADN

INTERFERENCE SEARCHED			
Class	Subclass	Date	Examiner

SEARCH NOTES (INCLUDING SEARCH STRATEGY)		
	DATE	EXMR
Considered IDS(s).	9/27/2010	HADN
Text serach in EAST.	9/27/2010	HADN
Text serach in EAST.	9/28/2010	HADN

## EAST Search History

## EAST Search History (Prior Art)

Ref #	Hits	Search Query	DBs	Default Operator	Plurals	Time Stamp
S1	2	("20090027068").PN.	US-PGPUB; USPAT; USOCR; FPRS; EPO; JPO; DERWENT; IBM_TDB	OR	OFF	2010/09/27 13:52
S2	10	("20090027068"   "5730165"   "6452494"   "6452514"   "6466036"). PN.	US-PGPUB; USPAT; USOCR; FPRS; EPO; JPO; DERWENT; IBM_TDB	OR	ON	2010/09/27 13:53
S3	638	(324/663.ccls.) and @ad<"20080722"	US-PGPUB; USPAT; USOCR; FPRS; EPO; JPO; DERWENT; IBM_TDB	OR	ON	2010/09/27 13:57
S4	700	(324/658.ccls.) and @ad<"20080722"	US-PGPUB; USPAT; USOCR; FPRS; EPO; JPO; DERWENT; IBM_TDB	OR	ON	2010/09/27 13:58
S5	183	(324/649.ccls.) and @ad<"20080722"	US-PGPUB; USPAT; USOCR; FPRS; EPO; JPO; DERWENT; IBM_TDB	OR	ON	2010/09/27 13:58
S6	210	(324/600.ccls.) and @ad<"20080722"	US-PGPUB; USPAT; USOCR; FPRS; EPO; JPO; DERWENT; IBM_TDB	OR	ON	2010/09/27 13:58
S7	1	gb-2431725-\$.did.	US-PGPUB; USPAT; USOCR; FPRS; EPO; JPO; DERWENT; IBM_TDB	OR	ON	2010/09/27 13:59
S8	2	ep-1536314-\$.did.	US-PGPUB; USPAT; USOCR; FPRS; EPO; JPO; DERWENT; IBM_TDB	OR	ON	2010/09/27 14:01



S9	5	((("20070076897") or ("20050114714") or ("7380145")).PN.	US-PGPUB; USPAT; USOCR; FPRS; EPO; JPO; DERWENT; IBM_TDB	OR	OFF	2010/09/27 14:03
S10	5	S2 and ((check\$3 detect\$3 sens\$3 examin\$3 determin\$3 recogniz\$3 inspect\$3 analy\$4 anali\$4 monitor\$3 diagnos\$3 identif\$4 record\$3 judg\$3 find\$3 indicat\$3 verif\$4 captur\$3) near2 (presen\$3 absen\$3 exist\$5 proximity appearance) near2 (object person body target finger subject member element structure cable wire component conductor human occupancy human driver operator occupancy occup\$5))	US-PGPUB; USPAT; USOCR; FPRS; EPO; JPO; DERWENT; IBM_TDB	OR	ON	2010/09/27 14:11
S11	68	S3 and ((check\$3 detect\$3 sens\$3 examin\$3 determin\$3 recogniz\$3 inspect\$3 analy\$4 anali\$4 monitor\$3 diagnos\$3 identif\$4 record\$3 judg\$3 find\$3 indicat\$3 verif\$4 captur\$3) near2 (presen\$3 absen\$3 exist\$5 proximity appearance) near2 (object person body target finger subject member element structure cable wire component conductor human occupancy human driver operator occupancy occup\$5))	US-PGPUB; USPAT; USOCR; FPRS; EPO; JPO; DERWENT; IBM_TDB	OR	ON	2010/09/27 14:12
S12	65	S4 and ((check\$3 detect\$3 sens\$3 examin\$3 determin\$3 recogniz\$3 inspect\$3 analy\$4 anali\$4 monitor\$3 diagnos\$3 identif\$4 record\$3 judg\$3 find\$3 indicat\$3 verif\$4 captur\$3) near2 (presen\$3 absen\$3 exist\$5 proximity appearance) near2 (object person body target finger subject member element structure cable wire component	US-PGPUB; USPAT; USOCR; FPRS; EPO; JPO; DERWENT; IBM_TDB	OR	ON	2010/09/27 14:13

		conductor human occupancy human driver operator occupancy occup \$5))				
S13	3	S5 and ((check\$3 detect\$3 sens\$3 examin\$3 determin \$3 recogniz\$3 inspect\$3 analy\$4 anali\$4 monitor\$3 diagnos\$3 identif\$4 record \$3 judg\$3 find\$3 indicat\$3 verif\$4 captur\$3) near2 (presen\$3 absen\$3 exist\$5 proximity appearance) near2 (object person body target finger subject member element structure cable wire component conductor human occupancy human driver operator occupancy occup \$5))	US-PGPUB; USPAT; USOCR; FPRS; EPO; JPO; DERWENT; IBM_TDB	OR	ON	2010/09/27 14:15
S14	4	S6 and ((check\$3 detect\$3 sens\$3 examin\$3 determin \$3 recogniz\$3 inspect\$3 analy\$4 anali\$4 monitor\$3 diagnos\$3 identif\$4 record \$3 judg\$3 find\$3 indicat\$3 verif\$4 captur\$3) near2 (presen\$3 absen\$3 exist\$5 proximity appearance) near2 (object person body target finger subject member element structure cable wire component conductor human occupancy human driver operator occupancy occup \$5))	US-PGPUB; USPAT; USOCR; FPRS; EPO; JPO; DERWENT; IBM_TDB	OR	ON	2010/09/27 14:16
S15	5	S10 and (check\$3 detect\$3 sens\$3 measur\$3 comput \$3 calculat\$3 \$2valuat\$3 examin\$3 test\$3 determin \$3 recogniz\$3 inspect\$3 analy\$4 anali\$4 monitor\$3 diagnos\$3 identif\$4 record \$3 meter\$3 gaug\$3 judg\$3 find\$3 indicat\$3 verif\$4 captur\$3) near2 capacitance	US-PGPUB; USPAT; USOCR; FPRS; EPO; JPO; DERWENT; IBM_TDB	OR	ON	2010/09/27 14:19

S16	51	S11 and (check\$3 detect\$3 sens\$3 measur\$3 comput\$3 calculat\$3 \$2valuat\$3 examin\$3 test\$3 determin\$3 recogniz\$3 inspect\$3 analy\$4 anali\$4 monitor\$3 diagnos\$3 identif\$4 record\$3 meter\$3 gaug\$3 judg\$3 find\$3 indicat\$3 verif\$4 captur\$3) near2 capacitance	US-PGPUB; USPAT; USOCR; FPRS; EPO; JPO; DERWENT; IBM_TDB	OR	ON	2010/09/27 14:21
S17	52	S12 and (check\$3 detect\$3 sens\$3 measur\$3 comput\$3 calculat\$3 \$2valuat\$3 examin\$3 test\$3 determin\$3 recogniz\$3 inspect\$3 analy\$4 anali\$4 monitor\$3 diagnos\$3 identif\$4 record\$3 meter\$3 gaug\$3 judg\$3 find\$3 indicat\$3 verif\$4 captur\$3) near2 capacitance	US-PGPUB; USPAT; USOCR; FPRS; EPO; JPO; DERWENT; IBM_TDB	OR	ON	2010/09/27 14:21
S18	1	S13 and (check\$3 detect\$3 sens\$3 measur\$3 comput\$3 calculat\$3 \$2valuat\$3 examin\$3 test\$3 determin\$3 recogniz\$3 inspect\$3 analy\$4 anali\$4 monitor\$3 diagnos\$3 identif\$4 record\$3 meter\$3 gaug\$3 judg\$3 find\$3 indicat\$3 verif\$4 captur\$3) near2 capacitance	US-PGPUB; USPAT; USOCR; FPRS; EPO; JPO; DERWENT; IBM_TDB	OR	ON	2010/09/27 14:23
S19	1	S14 and (check\$3 detect\$3 sens\$3 measur\$3 comput\$3 calculat\$3 \$2valuat\$3 examin\$3 test\$3 determin\$3 recogniz\$3 inspect\$3 analy\$4 anali\$4 monitor\$3 diagnos\$3 identif\$4 record\$3 meter\$3 gaug\$3 judg\$3 find\$3 indicat\$3 verif\$4 captur\$3) near2 capacitance	US-PGPUB; USPAT; USOCR; FPRS; EPO; JPO; DERWENT; IBM_TDB	OR	ON	2010/09/27 14:23

S20	4	S15 and ((check\$3 detect\$3 sens\$3 examin\$3 determin\$3 recogniz\$3 inspect\$3 analy\$4 anali\$4 monitor\$3 diagnos\$3 identif\$4 record\$3 judg\$3 find\$3 indicat\$3 verif\$4 captur\$3) near2 (presen\$3 absen\$3 exist\$5 proximity appearance) near2 (object person body target finger subject member element structure cable wire component conductor human occupancy human driver operator occupancy occup\$5)) with capacitance	US-PGPUB; USPAT; USOCR; FPRS; EPO; JPO; DERWENT; IBM_TDB	OR	ON	2010/09/27 14:25
S21	18	S16 and ((check\$3 detect\$3 sens\$3 examin\$3 determin\$3 recogniz\$3 inspect\$3 analy\$4 anali\$4 monitor\$3 diagnos\$3 identif\$4 record\$3 judg\$3 find\$3 indicat\$3 verif\$4 captur\$3) near2 (presen\$3 absen\$3 exist\$5 proximity appearance) near2 (object person body target finger subject member element structure cable wire component conductor human occupancy human driver operator occupancy occup\$5)) with capacitance	US-PGPUB; USPAT; USOCR; FPRS; EPO; JPO; DERWENT; IBM_TDB	OR	ON	2010/09/27 14:25
S22	32	S17 and ((check\$3 detect\$3 sens\$3 examin\$3 determin\$3 recogniz\$3 inspect\$3 analy\$4 anali\$4 monitor\$3 diagnos\$3 identif\$4 record\$3 judg\$3 find\$3 indicat\$3 verif\$4 captur\$3) near2 (presen\$3 absen\$3 exist\$5 proximity appearance) near2 (object person body target finger subject member element structure cable wire component conductor human occupancy human driver operator occupancy occup\$5)) with	US-PGPUB; USPAT; USOCR; FPRS; EPO; JPO; DERWENT; IBM_TDB	OR	ON	2010/09/27 14:26

S23	1	capacitance S18 and ((check\$3 detect \$3 sens\$3 examin\$3 determin\$3 recogniz\$3 inspect\$3 analy\$4 anali\$4 monitor\$3 diagnos\$3 identif\$4 record\$3 judg\$3 find\$3 indicat\$3 verif\$4 captur\$3) near2 (presen\$3 absen\$3 exist\$5 proximity appearance) near2 (object person body target finger subject member element structure cable wire component conductor human occupancy human driver operator occupancy occup\$5)) with capacitance	US-PGPUB; USPAT; USOCR; FPRS; EPO; JPO; DERWENT; IBM_TDB	OR	ON	2010/09/27 14:27
S24	0	S19 and ((check\$3 detect \$3 sens\$3 examin\$3 determin\$3 recogniz\$3 inspect\$3 analy\$4 anali\$4 monitor\$3 diagnos\$3 identif\$4 record\$3 judg\$3 find\$3 indicat\$3 verif\$4 captur\$3) near2 (presen\$3 absen\$3 exist\$5 proximity appearance) near2 (object person body target finger subject member element structure cable wire component conductor human occupancy human driver operator occupancy occup\$5)) with capacitance	US-PGPUB; USPAT; USOCR; FPRS; EPO; JPO; DERWENT; IBM_TDB	OR	ON	2010/09/27 14:28
S25	6	((("5,159,276") or ("5,730,165") or ("5,565,658")).PN.	US-PGPUB; USPAT; USOCR; FPRS; EPO; JPO; DERWENT; IBM_TDB	OR	OFF	2010/09/27 17:25

S26	2	S20 and ((presen\$3 absen\$3 exist\$5 proximity appearance) near2 (object person body target finger subject member element structure cable wire component conductor human occupancy human driver operator occupancy occup\$5)) with ((pre\$1select\$3 pre\$1determin\$3 pre\$1defin\$3 specif\$5 pre\$1set\$4 maximum minimum limit threshold reference desir\$5 expected wanted standard known model second spare bench\$1mark stored) near2 time near2 (period interval cycle duration shift relay range band block))	US-PGPUB; USPAT; USOCR; FPRS; EPO; JPO; DERWENT; IBM_TDB	OR	ON	2010/09/27 17:49
S27	0	S21 and ((presen\$3 absen\$3 exist\$5 proximity appearance) near2 (object person body target finger subject member element structure cable wire component conductor human occupancy human driver operator occupancy occup\$5)) with ((pre\$1select\$3 pre\$1determin\$3 pre\$1defin\$3 specif\$5 pre\$1set\$4 maximum minimum limit threshold reference desir\$5 expected wanted standard known model second spare bench\$1mark stored) near2 time near2 (period interval cycle duration shift relay range band block))	US-PGPUB; USPAT; USOCR; FPRS; EPO; JPO; DERWENT; IBM_TDB	OR	ON	2010/09/27 17:50

S28	1	\$22 and ((presen\$3 absen\$3 exist\$5 proximity appearance) near2 (object person body target finger subject member element structure cable wire component conductor human occupancy human driver operator occupancy occup\$5)) with ((pre\$1select\$3 pre\$1determin\$3 pre\$1defin\$3 specif\$5 pre\$1set\$4 maximum minimum limit threshold reference desir\$5 expected wanted standard known model second spare bench\$1mark stored) near2 time near2 (period interval cycle duration shift relay range band block))	US-PGPUB; USPAT; USOCR; FPRS; EPO; JPO; DERWENT; IBM_TDB	OR	ON	2010/09/27 17:51
S29	0	\$23 and ((presen\$3 absen\$3 exist\$5 proximity appearance) near2 (object person body target finger subject member element structure cable wire component conductor human occupancy human driver operator occupancy occup\$5)) with ((pre\$1select\$3 pre\$1determin\$3 pre\$1defin\$3 specif\$5 pre\$1set\$4 maximum minimum limit threshold reference desir\$5 expected wanted standard known model second spare bench\$1mark stored) near2 time near2 (period interval cycle duration shift relay range band block))	US-PGPUB; USPAT; USOCR; FPRS; EPO; JPO; DERWENT; IBM_TDB	OR	ON	2010/09/27 17:51
S30	5	(("20070076897") or ("20050114714") or ("7380145")).PN.	US-PGPUB; USPAT; USOCR; FPRS; EPO; JPO; DERWENT; IBM_TDB	OR	OFF	2010/09/28 11:12

S31	4	\$30 and ((check\$3 detect\$3 sens\$3 examin\$3 determin\$3 recogniz\$3 inspect\$3 analy\$4 anali\$4 monitor\$3 diagnos\$3 identif\$4 record\$3 judg\$3 find\$3 indicat\$3 verif\$4 captur\$3) near2 (presen\$3 absen\$3 exist\$5 proximity appearance) near2 (user object person body target finger subject member element structure cable wire component conductor human occupancy human driver operator occupancy occup\$5))	US-PGPUB; USPAT; USOCR; FPRS; EPO; JPO; DERWENT; IBM_TDB	OR	ON	2010/09/28 11:12
S33	2	\$31 and (check\$3 detect\$3 sens\$3 measur\$3 comput\$3 calculat\$3 \$2valuat\$3 examin\$3 test\$3 determin\$3 recogniz\$3 inspect\$3 analy\$4 anali\$4 monitor\$3 diagnos\$3 identif\$4 record\$3 meter\$3 gaug\$3 judg\$3 find\$3 indicat\$3 verif\$4 captur\$3) near2 capacitance	US-PGPUB; USPAT; USOCR; FPRS; EPO; JPO; DERWENT; IBM_TDB	OR	ON	2010/09/28 11:13
S39	5547	((((check\$3 detect\$3 sens\$3 examin\$3 determin\$3 recogniz\$3 inspect\$3 analy\$4 anali\$4 monitor\$3 diagnos\$3 identif\$4 record\$3 judg\$3 find\$3 indicat\$3 verif\$4 captur\$3) near2 (presen\$3 absen\$3 exist\$5 proximity appearance) near2 (user object person body target finger subject member element structure cable wire component conductor human occupancy human driver operator occupancy occup\$5)).ti.) and @ad<"20080722"	US-PGPUB; USPAT; USOCR; FPRS; EPO; JPO; DERWENT; IBM_TDB	OR	ON	2010/09/28 16:46



S40	28437	((check\$3 detect\$3 sens\$3 examin\$3 determin\$3 recogniz\$3 inspect\$3 analy\$4 anali\$4 monitor\$3 diagnos\$3 identif\$4 record\$3 judg\$3 find\$3 indicat\$3 verif\$4 captur\$3) near2 (presen\$3 absen\$3 exist\$5 proximity appearance) near2 (user object person body target finger subject member element structure cable wire component conductor human occupancy human driver operator occupancy occup\$5)).ab.) and @ad<"20080722"	US-PGPUB; USPAT; USOCR; FPRS; EPO; JPO; DERWENT; IBM_TDB	OR	ON	2010/09/28 16:47
S41	120275	((check\$3 detect\$3 sens\$3 examin\$3 determin\$3 recogniz\$3 inspect\$3 analy\$4 anali\$4 monitor\$3 diagnos\$3 identif\$4 record\$3 judg\$3 find\$3 indicat\$3 verif\$4 captur\$3) near2 (presen\$3 absen\$3 exist\$5 proximity appearance) near2 (user object person body target finger subject member element structure cable wire component conductor human occupancy human driver operator occupancy occup\$5)) and @ad<"20080722"	US-PGPUB; USPAT; USOCR; FPRS; EPO; JPO; DERWENT; IBM_TDB	OR	ON	2010/09/28 16:48
S42	186	\$39 and (check\$3 detect\$3 sens\$3 measur\$3 comput\$3 calculat\$3 \$2valuat\$3 examin\$3 test\$3 determin\$3 recogniz\$3 inspect\$3 analy\$4 anali\$4 monitor\$3 diagnos\$3 identif\$4 record\$3 meter\$3 gaug\$3 judg\$3 find\$3 indicat\$3 verif\$4 captur\$3) near2 capacitance	US-PGPUB; USPAT; USOCR; FPRS; EPO; JPO; DERWENT; IBM_TDB	OR	ON	2010/09/28 16:49

S43	694	S40 and (check\$3 detect\$3 sens\$3 measur\$3 comput\$3 calculat\$3 \$2valuat\$3 examin\$3 test\$3 determin\$3 recogniz\$3 inspect\$3 analy\$4 anali\$4 monitor\$3 diagnos\$3 identif\$4 record\$3 meter\$3 gaug\$3 judg\$3 find\$3 indicat\$3 verif\$4 captur\$3) near2 capacitance	US-PGPUB; USPAT; USOCR; FPRS; EPO; JPO; DERWENT; IBM_TDB	OR	ON	2010/09/28 16:49
S44	3787	S41 and (check\$3 detect\$3 sens\$3 measur\$3 comput\$3 calculat\$3 \$2valuat\$3 examin\$3 test\$3 determin\$3 recogniz\$3 inspect\$3 analy\$4 anali\$4 monitor\$3 diagnos\$3 identif\$4 record\$3 meter\$3 gaug\$3 judg\$3 find\$3 indicat\$3 verif\$4 captur\$3) near2 capacitance	US-PGPUB; USPAT; USOCR; FPRS; EPO; JPO; DERWENT; IBM_TDB	OR	ON	2010/09/28 16:50
S45	113	S42 and ((check\$3 detect\$3 sens\$3 examin\$3 determin\$3 recogniz\$3 inspect\$3 analy\$4 anali\$4 monitor\$3 diagnos\$3 identif\$4 record\$3 judg\$3 find\$3 indicat\$3 verif\$4 captur\$3) near2 (presen\$3 absen\$3 exist\$5 proximity appearance) near2 (user object person body target finger subject member element structure cable wire component conductor human occupancy human driver operator occupancy occup\$5)) with capacitance	US-PGPUB; USPAT; USOCR; FPRS; EPO; JPO; DERWENT; IBM_TDB	OR	ON	2010/09/28 16:51

S46	305	S43 and ((check\$3 detect\$3 sens\$3 examin\$3 determin\$3 recogniz\$3 inspect\$3 analy\$4 anali\$4 monitor\$3 diagnos\$3 identif\$4 record\$3 judg\$3 find\$3 indicat\$3 verif\$4 captur\$3) near2 (presen\$3 absen\$3 exist\$5 proximity appearance) near2 (user object person body target finger subject member element structure cable wire component conductor human occupancy human driver operator occupancy occup\$5)) with capacitance	US-PGPUB; USPAT; USOCR; FPRS; EPO; JPO; DERWENT; IBM_TDB	OR	ON	2010/09/28 16:52
S47	920	S44 and ((check\$3 detect\$3 sens\$3 examin\$3 determin\$3 recogniz\$3 inspect\$3 analy\$4 anali\$4 monitor\$3 diagnos\$3 identif\$4 record\$3 judg\$3 find\$3 indicat\$3 verif\$4 captur\$3) near2 (presen\$3 absen\$3 exist\$5 proximity appearance) near2 (user object person body target finger subject member element structure cable wire component conductor human occupancy human driver operator occupancy occup\$5)) with capacitance	US-PGPUB; USPAT; USOCR; FPRS; EPO; JPO; DERWENT; IBM_TDB	OR	ON	2010/09/28 16:53
S48	1	S45 and ((presen\$3 absen\$3 exist\$5 proximity appearance) near2 (user object person body target finger subject member element structure cable wire component conductor human occupancy human driver operator occupancy occup\$5)) with ((pre\$1select\$3 pre\$1determin\$3 pre\$1defin\$3 specif\$5 pre\$1set\$4 maximum minimum limit threshold reference desir\$5 expected wanted standard known model second spare bench	US-PGPUB; USPAT; USOCR; FPRS; EPO; JPO; DERWENT; IBM_TDB	OR	ON	2010/09/28 16:54

		\$1mark stored) near2 time near2 (period interval cycle duration shift relay range band block))				
S49	7	\$46 and ((presen\$3 absen \$3 exist\$5 proximity appearance) near2 (user object person body target finger subject member element structure cable wire component conductor human occupancy human driver operator occupancy occup\$5)) with ((pre \$1select\$3 pre\$1determin \$3 pre\$1defin\$3 specif\$5 pre\$1set\$4 maximum minimum limit threshold reference desir\$5 expected wanted standard known model second spare bench \$1mark stored) near2 time near2 (period interval cycle duration shift relay range band block))	US-PGPUB; USPAT; USOCR; FPRS; EPO; JPO; DERWENT; IBM_TDB	OR	ON	2010/09/28 16:55
S50	17	\$47 and ((presen\$3 absen \$3 exist\$5 proximity appearance) near2 (user object person body target finger subject member element structure cable wire component conductor human occupancy human driver operator occupancy occup\$5)) with ((pre \$1select\$3 pre\$1determin \$3 pre\$1defin\$3 specif\$5 pre\$1set\$4 maximum minimum limit threshold reference desir\$5 expected wanted standard known model second spare bench \$1mark stored) near2 time near2 (period interval cycle duration shift relay range band block))	US-PGPUB; USPAT; USOCR; FPRS; EPO; JPO; DERWENT; IBM_TDB	OR	ON	2010/09/28 16:56
S51	1118	(702/57.ccls.) and @ad<"20080722"	US-PGPUB; USPAT; USOCR; FPRS; EPO; JPO; DERWENT; IBM_TDB	OR	ON	2010/09/28 16:57

S52	43	\$S1 and ((check\$3 detect\$3 sens\$3 examin\$3 determin\$3 recogniz\$3 inspect\$3 analy\$4 anali\$4 monitor\$3 diagnos\$3 identif\$4 record\$3 judg\$3 find\$3 indicat\$3 verif\$4 captur\$3) near2 (presen\$3 absen\$3 exist\$5 proximity appearance) near2 (user object person body target finger subject member element structure cable wire component conductor human occupancy human driver operator occupancy occup\$5))	US-PGPUB; USPAT; USOCR; FPRS; EPO; JPO; DERWENT; IBM_TDB	OR	ON	2010/09/28 16:58
S53	8	\$S2 and (check\$3 detect\$3 sens\$3 measur\$3 comput\$3 calculat\$3 \$2valuat\$3 examin\$3 test\$3 determin\$3 recogniz\$3 inspect\$3 analy\$4 anali\$4 monitor\$3 diagnos\$3 identif\$4 record\$3 meter\$3 gaug\$3 judg\$3 find\$3 indicat\$3 verif\$4 captur\$3) near2 capacitance	US-PGPUB; USPAT; USOCR; FPRS; EPO; JPO; DERWENT; IBM_TDB	OR	ON	2010/09/28 16:59
S54	3	\$S3 and ((check\$3 detect\$3 sens\$3 examin\$3 determin\$3 recogniz\$3 inspect\$3 analy\$4 anali\$4 monitor\$3 diagnos\$3 identif\$4 record\$3 judg\$3 find\$3 indicat\$3 verif\$4 captur\$3) near2 (presen\$3 absen\$3 exist\$5 proximity appearance) near2 (user object person body target finger subject member element structure cable wire component conductor human occupancy human driver operator occupancy occup\$5)) with capacitance	US-PGPUB; USPAT; USOCR; FPRS; EPO; JPO; DERWENT; IBM_TDB	OR	ON	2010/09/28 17:00
S55	0	\$A2 and general adj2 purpose adj2 (micro \$Iprocess\$3 micro \$Icontrol\$5 CPU)	US-PGPUB; USPAT; USOCR; FPRS; EPO; JPO; DERWENT; IBM_TDB	OR	ON	2010/09/28 17:04

S56	3	S43 and general adj2 purpose adj2 (micro \$1process\$3 micro \$1control\$5 CPU)	US-PGPUB; USPAT; USOCR; FPRS; EPO; JPO; DERWENT; IBM_TDB	OR	ON	2010/09/28 17:04
S57	28	S44 and general adj2 purpose adj2 (micro \$1process\$3 micro \$1control\$5 CPU)	US-PGPUB; USPAT; USOCR; FPRS; EPO; JPO; DERWENT; IBM_TDB	OR	ON	2010/09/28 17:04
S58	0	S42 and (IC (integrated adj circuit) \$6chip ASIC semi \$1conduct\$3 transistor) near2 ((six adj (pin terminal)) "six-pin" "six-terminal")	US-PGPUB; USPAT; USOCR; FPRS; EPO; JPO; DERWENT; IBM_TDB	OR	ON	2010/09/28 17:10
S59	0	S43 and (IC (integrated adj circuit) \$6chip ASIC semi \$1conduct\$3 transistor) near2 ((six adj (pin terminal)) "six-pin" "six-terminal")	US-PGPUB; USPAT; USOCR; FPRS; EPO; JPO; DERWENT; IBM_TDB	OR	ON	2010/09/28 17:11
S60	0	S44 and (IC (integrated adj circuit) \$6chip ASIC semi \$1conduct\$3 transistor) near2 ((six adj (pin terminal)) "six-pin" "six-terminal")	US-PGPUB; USPAT; USOCR; FPRS; EPO; JPO; DERWENT; IBM_TDB	OR	ON	2010/09/28 17:11
S61	0	S42 and (IC (integrated adj circuit) \$6chip ASIC semi \$1conduct\$3 transistor) with ((six adj (pin terminal)) "six-pin" "six-terminal")	US-PGPUB; USPAT; USOCR; FPRS; EPO; JPO; DERWENT; IBM_TDB	OR	ON	2010/09/28 17:12
S62	0	S43 and (IC (integrated adj circuit) \$6chip ASIC semi \$1conduct\$3 transistor) with ((six adj (pin terminal)) "six-pin" "six-terminal")	US-PGPUB; USPAT; USOCR; FPRS; EPO; JPO; DERWENT; IBM_TDB	OR	ON	2010/09/28 17:12
S63	0	S44 and (IC (integrated adj circuit) \$6chip ASIC semi \$1conduct\$3 transistor) with ((six adj (pin terminal)) "six-pin" "six-terminal")	US-PGPUB; USPAT; USOCR; FPRS; EPO; JPO; DERWENT; IBM_TDB	OR	ON	2010/09/28 17:12

S64	108	((IC (integrated adj circuit) \$6chip ASIC semi \$1conduct\$3 transistor) near2 ((six adj (pin terminal)) "six-pin" "six-terminal")) and @ad<"20080722"	US-PGPUB; USPAT; USOCR; FPRS; EPO; JPO; DERWENT; IBM_TDB	OR	ON	2010/09/28 17:13
S65	0	S64 and ((check\$3 detect \$3 sens\$3 examin\$3 determin\$3 recogniz\$3 inspect\$3 analy\$4 anali\$4 monitor\$3 diagnos\$3 identif\$4 record\$3 judg\$3 find\$3 indicat\$3 verif\$4 captur\$3) near2 (presen\$3 absen\$3 exist\$5 proximity appearance) near2 (user object person body target finger subject member element structure cable wire component conductor human occupancy human driver operator occupancy occup\$5))	US-PGPUB; USPAT; USOCR; FPRS; EPO; JPO; DERWENT; IBM_TDB	OR	ON	2010/09/28 17:13
S66	0	S64 and ((check\$3 detect \$3 sens\$3 examin\$3 determin\$3 recogniz\$3 inspect\$3 analy\$4 anali\$4 monitor\$3 diagnos\$3 identif\$4 record\$3 judg\$3 find\$3 indicat\$3 verif\$4 captur\$3) near2 (presen\$3 absen\$3 exist\$5 proximity appearance) near2 (user object person body target finger subject member element structure cable wire component conductor human occupancy human driver operator occupancy occup\$5)) with capacitance	US-PGPUB; USPAT; USOCR; FPRS; EPO; JPO; DERWENT; IBM_TDB	OR	ON	2010/09/28 17:14

S67	2	S64 and (check\$3 detect\$3 sens\$3 measur\$3 comput \$3 calculat\$3 \$2valuat\$3 examin\$3 test\$3 determin \$3 recogniz\$3 inspect\$3 analy\$4 anali\$4 monitor\$3 diagnos\$3 identif\$4 record \$3 meter\$3 gaug\$3 judg\$3 find\$3 indicat\$3 verif\$4 captur\$3) near2 capacitance	US-PGPUB; USPAT; USOCR; FPRS; EPO; JPO; DERWENT; IBM_TDB	OR	ON	2010/09/28 17:15
-----	---	---	--	----	----	---------------------

**EAST Search History (Interference)**

<This search history is empty>

**9/29/10 11:40:46 AM**

**C:\Documents and Settings\hnguyen26\My Documents\EAST\Workspaces\12179769.wsp**



Receipt date: 01/14/2010

12179769 - GAU: 2831

PTO/SB/08A(04-07)  
 Modified form approved for use through 09/30/2007. OMB 651-0031  
 US Patent & Trademark Office: U.S. DEPARTMENT OF COMMERCE

Under the Paperwork Reduction Act of 1995, no persons are required to respond to a collection of information unless it contains a valid OMB control number.

Substitute for form 1449A/PTO <b>INFORMATION DISCLOSURE STATEMENT BY APPLICANT</b> (Use as many sheets as necessary)	<i>Complete if Known</i>	
	<b>Application Number</b>	12/179,769
	<b>Filing Date</b>	July 25, 2008
	<b>First Named Inventor</b>	Harald Philipp
	<b>Group Art Unit</b>	<del>Unknown</del>
	<b>Examiner Name</b>	<del>Diego Gutierrez</del> /Hoai-An Nguyen/
Sheet 1 of 1	Attorney Docket No: 3050.030US1	

US PATENT DOCUMENTS				
Examiner Initial *	USP Document Number	Publication Date	Name of Patentee or Applicant of cited Document	Filing Date If Appropriate
/HADN/	US-20090027068A1	01/29/2009	Philipp, et al.	07/25/2008

FOREIGN PATENT DOCUMENTS				
Examiner Initials*	Foreign Document No	Publication Date	Name of Patentee or Applicant of cited Document	T <sup>1</sup>
/HADN/	EP-1536314A2	06/01/2005	Albulet, M.	
/HADN/	GB-2431725A1	05/02/2007	Harald, P.	

OTHER DOCUMENTS – NON PATENT LITERATURE DOCUMENTS		
Examiner Initials*	Include name of the author (in CAPITAL LETTERS), title of the article (when appropriate), title of the item (book, magazine, journal, serial, symposium, catalog, etc.), date, page(s), volume-issue number(s), publisher, city and/or country where published.	T <sup>1</sup>

EXAMINER /Hoai-An Nguyen/

DATE CONSIDERED 09/27/2010

\* EXAMINER: Initial if reference considered, whether or not citation is in conformance with MPEP 609. Draw line through citation if not in conformance and not considered. Include copy of this form with next communication to applicant. 1 Applicant is to place a check mark here if English language Translation is attached

Receipt date: 07/25/2008

Doc code :IDS

Doc description: Information Disclosure Statement (IDS) Filed

PTO/SB/08a (03-08)

Approved for use through 07/31/2008. OMB 0651-0031

U.S. Patent and Trademark Office; U.S. DEPARTMENT OF COMMERCE

Under the Paperwork Reduction Act of 1995, no persons are required to respond to a collection of information unless it contains a valid OMB control number.

<b>INFORMATION DISCLOSURE STATEMENT BY APPLICANT</b> ( Not for submission under 37 CFR 1.99)	Application Number	12179769
	Filing Date	2008-07-25
	First Named Inventor	Philipp
	Art Unit	12179769 - GAU: 2831
	Examiner Name	/Hoai-An Nguyen/
	Attorney Docket Number	QAP

U.S. PATENTS							Remove
Examiner Initial*	Cite No	Patent Number	Kind Code <sup>1</sup>	Issue Date	Name of Patentee or Applicant of cited Document	Pages, Columns, Lines where Relevant Passages or Relevant Figures Appear	
/HADN/	1	5730165	A	1998-03-24	Philipp	/	
/HADN/	2	6466036	B1	2002-10-15	Philipp		
/HADN/	3	6452514	B1	2002-09-17	Philipp		

If you wish to add additional U.S. Patent citation information please click the Add button.

Add

U.S. PATENT APPLICATION PUBLICATIONS							Remove
Examiner Initial*	Cite No	Publication Number	Kind Code <sup>1</sup>	Publication Date	Name of Patentee or Applicant of cited Document	Pages, Columns, Lines where Relevant Passages or Relevant Figures Appear	
	1					/	

If you wish to add additional U.S. Published Application citation information please click the Add button.

Add

FOREIGN PATENT DOCUMENTS								Remove
Examiner Initial*	Cite No	Foreign Document Number <sup>3</sup>	Country Code <sup>2</sup> j	Kind Code <sup>4</sup>	Publication Date	Name of Patentee or Applicant of cited Document	Pages, Columns, Lines where Relevant Passages or Relevant Figures Appear	T <sup>5</sup>
	1							<input type="checkbox"/>

<b>INFORMATION DISCLOSURE STATEMENT BY APPLICANT</b> ( Not for submission under 37 CFR 1.99)	Application Number		12179769
	Filing Date		2008-07-25
	First Named Inventor	Philipp	
	Art Unit		12179769 - GAU: 2831
	Examiner Name		/Hoai-An Nguyen/
	Attorney Docket Number		QAP

If you wish to add additional Foreign Patent Document citation information please click the Add button				<input type="button" value="Add"/>
<b>NON-PATENT LITERATURE DOCUMENTS</b>				<input type="button" value="Remove"/>
Examiner Initials*	Cite No	Include name of the author (in CAPITAL LETTERS), title of the article (when appropriate), title of the item (book, magazine, journal, serial, symposium, catalog, etc), date, pages(s), volume-issue number(s), publisher, city and/or country where published.	T <sup>5</sup>	
	1		<input type="checkbox"/>	
If you wish to add additional non-patent literature document citation information please click the Add button				<input type="button" value="Add"/>
<b>EXAMINER SIGNATURE</b>				
Examiner Signature		/Hoai-An Nguyen/	Date Considered	09/27/2010
*EXAMINER: Initial if reference considered, whether or not citation is in conformance with MPEP 609. Draw line through a citation if not in conformance and not considered. Include copy of this form with next communication to applicant.				
<sup>1</sup> See Kind Codes of USPTO Patent Documents at <a href="http://www.USPTO.GOV">www.USPTO.GOV</a> or MPEP 901.04. <sup>2</sup> Enter office that issued the document, by the two-letter code (WIPO Standard ST.3). <sup>3</sup> For Japanese patent documents, the indication of the year of the reign of the Emperor must precede the serial number of the patent document. <sup>4</sup> Kind of document by the appropriate symbols as indicated on the document under WIPO Standard ST.16 if possible. <sup>5</sup> Applicant is to place a check mark here if English language translation is attached.				



Under the Paperwork Reduction Act of 1995, no persons are required to respond to a collection of information unless it contains a valid OMB control number.

Substitute for form 1449/PTO  <b>INFORMATION DISCLOSURE STATEMENT BY APPLICANT</b>  (Use as many sheets as necessary)				<b>Complete if Known</b>		
				Application Number	12/179769	
				Filing Date	07/25/2008	
				First Named Inventor	Phillip	
				Art Unit	— 12179769 - GAU: 2831	
				Examiner Name	— /Hoai-An Nguyen/	
Sheet	2	of	2	Attorney Docket Number	QAP	

NON PATENT LITERATURE DOCUMENTS			
Examiner Initials*	Cite No. <sup>1</sup>	Include name of the author (in CAPITAL LETTERS), title of the article (when appropriate), title of the item (book, magazine, journal, serial, symposium, catalog, etc.), date, page(s), volume-issue number(s), publisher, city and/or country where published.	T <sup>2</sup>
/HADN/		UK INTELLECTUAL PROPERTY OFFICE, Search Report in GB 0813682.2, mailed November 4, 2008	
/HADN/		Data sheet "QT100 - Charge Transfer IC" Quantum Research Gp. Published 2006	
/HADN/		Data sheet "QT110 Touch Sensor IC" Quantum Research Group, published 2004	
/			

Examiner Signature	/Hoai-An Nguyen/	Date Considered	09/27/2010
--------------------	------------------	-----------------	------------

\*EXAMINER: Initial if reference considered, whether or not citation is in conformance with MPEP 609. Draw line through citation if not in conformance and not considered. Include copy of this form with next communication to applicant.  
 1 Applicant's unique citation designation number (optional). 2 Applicant is to place a check mark here if English language Translation is attached.  
 This collection of information is required by 37 CFR 1.98. The information is required to obtain or retain a benefit by the public which is to file (and by the USPTO to process) an application. Confidentiality is governed by 35 U.S.C. 122 and 37 CFR 1.14. This collection is estimated to take 2 hours to complete, including gathering, preparing, and submitting the completed application form to the USPTO. Time will vary depending upon the individual case. Any comments on the amount of time you require to complete this form and/or suggestions for reducing this burden, should be sent to the Chief Information Officer, U.S. Patent and Trademark Office, P.O. Box 1450, Alexandria, VA 22313-1450. DO NOT SEND FEES OR COMPLETED FORMS TO THIS ADDRESS. SEND TO: Commissioner for Patents, P.O. Box 1450, Alexandria, VA 22313-1450.

If you need assistance in completing the form, call 1-800-PTO-9199 (1-800-786-9199) and select option 2.

S/N 12/179,769

PATENT

IN THE UNITED STATES PATENT AND TRADEMARK OFFICE

Applicant: Harald Philipp et al.

Examiner: Hoai-An Nguyen

Serial No.: 12/179,769

Group Art Unit: 2831

Filed: July 25, 2008

Docket No.: 3050.030US1

Customer No.: 76287

Confirmation No.: 8745

Title: Proximity Sensor

---

AMENDMENT & RESPONSE UNDER 37 C.F.R. § 1.111

Mail Stop Amendment  
Commissioner for Patents  
P.O. Box 1450  
Alexandria, VA 22313-1450

In response to the Office Action dated October 4, 2010, please amend the application as follows:

**IN THE ABSTRACT OF THE DISCLOSURE**

Please amend the Abstract as follows:

A capacitive touch sensor providing an automatic switch-off function for an apparatus in which the sensor is incorporated is provided. The sensor ~~includes~~comprises a sensing element coupled to a capacitance measurement circuit for measuring the capacitance of the sensing element. A control circuit is operable to determine from the capacitance measurement whether an object is in proximity with the sensor. The determined presence of an object may be used to toggle a function of the apparatus. Furthermore, when it is determined that an object has not been in proximity with the sensor for a predetermined time duration, an output signal for switching off the apparatus is provided. The predetermined time duration may be selected from a number of predefined time durations, or may be programmed using a ~~a~~an resistor-capacitor network. Pulses may be applied to the control circuit to override features of the automatic switch-off functionality.

IN THE CLAIMS

Please amend the claims as follows:

1. (Currently Amended) A sensor for determining the presence of an object comprising:  
a sensing element;  
a capacitance measurement circuit operable to measure the capacitance of the sensing element; and  
a control circuit operable to determine whether ~~the~~an object is in proximity with the sensor based on a measurement of the capacitance of the sensing element, the control circuit further being operable to provide an output signal to control a function of an apparatus when it is determined that ~~the~~an object has not been in proximity with the sensor for a predetermined time duration, wherein the control circuit includes a time input terminal and the predetermined time duration is selectable from the number of different predefined time durations according to a voltage applied to the time input terminal, and wherein the control circuit includes a delay multiplier terminal and is configured so that a selected one of the number of different predefined time durations is multiplied by a multiplication factor according to a voltage applied to the delay multiplier terminal to provide the predetermined time duration.

2-4. (Cancelled)

5. (Currently Amended) ~~The sensor of claim 1.~~A sensor for determining the presence of an object comprising:  
a sensing element;  
a capacitance measurement circuit operable to measure the capacitance of the sensing element; and  
a control circuit operable to determine whether an object is in proximity with the sensor based on a measurement of the capacitance of the sensing element, the control circuit further being operable to provide an output signal to control a function of an apparatus when it is determined that an object has not been in proximity with the sensor for a predetermined time duration, wherein the control circuit is configured so that the predetermined time duration is



---

programmable by a user to provide a user-selected time duration, and wherein the control circuit includes a delay multiplier terminal and is configured so that the user-selected time duration is multiplied by a multiplication factor according to a voltage applied to the delay multiplier terminal to provide the predetermined time duration.

6. (Original) The sensor of claim 5, further comprising a resistor-capacitor (RC) network coupled to the control circuit and wherein the predetermined time duration depends on a time constant of the RC network.

7. (Cancelled)

8. (Original) The sensor of claim 1, wherein the control circuit is configured such that the provision of the output signal to control a function of an apparatus after the predetermined time duration may be overridden so the output signal is not provided when it is determined that an object has not been in proximity with the sensor for a predetermined time duration.

9. (Original) The sensor of claim 8, wherein the control circuit is operable to receive an override pulse and on receipt of the override pulse to retrigger the predetermined time duration to so as to extend the time before the output signal to control a function of an apparatus is provided.

10. (Original) The sensor of claim 1, wherein the control circuit is configured such that the provision of the output signal to control a function of an apparatus after the predetermined time duration may be overridden so the output signal is provided before it is determined that an object has not been in proximity with the sensor for a predetermined time duration.

11. (Original) The sensor of claim 10, wherein the control circuit is operable to receive an override pulse and on receipt of the override pulse to provide the output signal to control a function of an apparatus.

---

12. (Original) The sensor of claim 1, wherein the sensor is configured to perform a recalibration when the sensor is powered up, when an object is determined to be in proximity with the sensor for more than a timer setting, and / or when an override is released.

13. (Original) The sensor of claim 1, wherein the control circuit is configured such that the output signal is toggled between a high state and a low state when an object is determined to be in proximity with the sensor.

14. (Currently Amended) The sensor of claim 1, wherein the function of ~~the~~ apparatus controlled by the output signal is a switch-off function.

15. (Original) The sensor of claim 1, wherein the capacitance measurement circuit employs bursts of charge-transfer cycles to acquire measurements.

16. (Original) The sensor of claim 1, wherein the capacitance measurement circuit is configured to operate in one of more than one acquisition modes depending on the output signal.

17. (Original) The sensor of claim 16, wherein a one of the more than one acquisition modes is a low-power mode.

18. (Original) The sensor of claim 16, wherein a one of the more than one acquisition modes is a fast mode.

19. (Original) The sensor of claim 1, wherein the capacitance measurement circuit and the control circuit are comprised in a general purpose microcontroller under firmware control.

20. (Original) The sensor of claim 1, wherein the capacitance measurement circuit and the control circuit are comprised within a six-pin integrated circuit chip package.

21. (Original) An apparatus comprising a sensor according to claim 1.

22-23. (Cancelled)

### REMARKS

This responds to the Office Action dated October 4, 2010.

Claims 1, 5, and 14 are amended. Claims 2-4, 7, and 22-23 are canceled. Claims 1, 5-6, and 8-21 are now pending in this application.

#### Specification Objections

The abstract was objected to. The abstract has been amended to address the objection by replacing “comprises” with “includes”. A minor typographical correction has also been made.

#### Claim Objections

Claims 1, 14 and 22 are objected to due to informalities. Claims 1 and 14 have been amended to correct the informalities. Claim 22 has been cancelled.

#### The Rejection of Claims Under § 102

Claims 1-3, 5, 6, 8-18 and 21-23 are rejected under 35 U.S.C. § 102(b) as being anticipated by Philipp (U.S. Publication No. 2007/0076897A1). Independent claim 1 has been amended to incorporate the elements of allowable claim 4, including the limitations of all intervening claims of claim 4. Claim 5 has been amended to independent form, incorporating all the elements of allowable claim 7 along with the limitations of all intervening claims, including original claim 1. Thus, claims 1 and 5 have been placed in allowable condition, along with the remaining dependent claims to place all the claims in condition for allowance.

#### The Rejection of Claims Under § 103

Claim 19 is rejected under 35 U.S.C. § 103(a) as being unpatentable over Philipp (U.S. Publication No. 2007/0076897A1) in view of Philipp et al. (U.S. Publication No. 2007/0062739A1). This rejection is believed moot in view of the amendments placing all the claims in condition for allowance.

Claim 20 is rejected under 35 U.S.C. § 103(a) as being unpatentable over Philipp (U.S. Publication No. 2007/0076897A1) in view of Lee (U.S. Patent No. 7,091,727B2). This rejection is believed moot in view of the amendments placing all the claims in condition for allowance.

Allowable Subject Matter

Claims 4 and 7 are objected to as being dependent upon a rejected base claim, but would be allowable if rewritten in independent form including all of the limitations of the base claim and any intervening claims. Claim 1 has been amended to include all the limitations of allowable claim 4 along with the elements of all intervening claims. Claim 5 has been amended to include all the limitations of allowable claim 7 along with the elements of all intervening claims including original claim 1.

CONCLUSION

Applicant respectfully submits that the claims are in condition for allowance, and notification to that effect is earnestly requested. The Examiner is invited to telephone the undersigned at (612) 373-6972 to facilitate prosecution of this application.

If necessary, please charge any additional fees or deficiencies, or credit any overpayments to Deposit Account No. 19-0743.

Respectfully submitted,

SCHWEGMAN, LUNDBERG & WOESSNER, P.A.  
P.O. Box 2938  
Minneapolis, MN 55402--0938  
(612) 373-6972

Date 4 January 2011

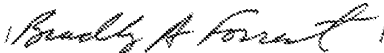
By   
Bradley A. Forrest  
Reg. No. 30,837

CERTIFICATE UNDER 37 CFR 1.8: The undersigned hereby certifies that this correspondence is being filed using the USPTO's electronic filing system EFS-Web, and is addressed to: Mail Stop Amendment, Commissioner for Patents, P.O. Box 1450, Alexandria, VA 22313-1450 on this 4th day of January, 2011.

Nicole Jack  
Name \_\_\_\_\_

  
Signature

## Electronic Acknowledgement Receipt

<b>EFS ID:</b>	9162156
<b>Application Number:</b>	12179769
<b>International Application Number:</b>	
<b>Confirmation Number:</b>	8745
<b>Title of Invention:</b>	Proximity Sensor
<b>First Named Inventor/Applicant Name:</b>	Harald Philipp
<b>Customer Number:</b>	76287
<b>Filer:</b>	David W. Black/Nicole Jack
<b>Filer Authorized By:</b>	David W. Black
<b>Attorney Docket Number:</b>	3050.030US1
<b>Receipt Date:</b>	04-JAN-2011
<b>Filing Date:</b>	25-JUL-2008
<b>Time Stamp:</b>	16:44:05
<b>Application Type:</b>	Utility under 35 USC 111(a)

### Payment information:

Submitted with Payment	no
------------------------	----

### File Listing:

Document Number	Document Description	File Name	File Size(Bytes)/ Message Digest	Multi Part /.zip	Pages (if appl.)
1		3050030US1RESPONSE.pdf	75756 94e0442931c270ec67263a88aa9425951145be8e	yes	10

<b>Multipart Description/PDF files in .zip description</b>		
<b>Document Description</b>	<b>Start</b>	<b>End</b>
Miscellaneous Incoming Letter	1	1
Amendment/Req. Reconsideration-After Non-Final Reject	2	2
Abstract	3	3
Claims	4	7
Applicant Arguments/Remarks Made in an Amendment	8	10
<b>Warnings:</b>		
<b>Information:</b>		
<b>Total Files Size (in bytes):</b>		75756
<p>This Acknowledgement Receipt evidences receipt on the noted date by the USPTO of the indicated documents, characterized by the applicant, and including page counts, where applicable. It serves as evidence of receipt similar to a Post Card, as described in MPEP 503.</p> <p><b><u>New Applications Under 35 U.S.C. 111</u></b>  If a new application is being filed and the application includes the necessary components for a filing date (see 37 CFR 1.53(b)-(d) and MPEP 506), a Filing Receipt (37 CFR 1.54) will be issued in due course and the date shown on this Acknowledgement Receipt will establish the filing date of the application.</p> <p><b><u>National Stage of an International Application under 35 U.S.C. 371</u></b>  If a timely submission to enter the national stage of an international application is compliant with the conditions of 35 U.S.C. 371 and other applicable requirements a Form PCT/DO/EO/903 indicating acceptance of the application as a national stage submission under 35 U.S.C. 371 will be issued in addition to the Filing Receipt, in due course.</p> <p><b><u>New International Application Filed with the USPTO as a Receiving Office</u></b>  If a new international application is being filed and the international application includes the necessary components for an international filing date (see PCT Article 11 and MPEP 1810), a Notification of the International Application Number and of the International Filing Date (Form PCT/RO/105) will be issued in due course, subject to prescriptions concerning national security, and the date shown on this Acknowledgement Receipt will establish the international filing date of the application.</p>		



IN THE UNITED STATES PATENT AND TRADEMARK OFFICE

Applicant: Harald Philipp et al.

Title: Proximity Sensor

Docket No.: 3050.030US1  
Filed: July 25, 2008  
Examiner: Hoai-An Nguyen  
Customer No.: 76287

Serial No.: 12/179,769  
Due Date: January 4, 2011  
Group Art Unit: 2831  
Confirmation No.: 8745

Mail Stop Amendment  
Commissioner for Patents  
P.O. Box 1450  
Alexandria, VA 22313-1450

We are transmitting herewith the following attached items (as indicated with an "X"):

Amendment and Response under 37 C.F.R. § 1.111 (9 pgs.)

Please charge any additional fees or credit overpayment to Deposit Account No. 19-0743.

SCHWEGMAN, LUNDBERG & WOESSNER, P.A.  
Customer No.: 76287

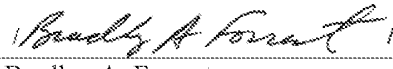
By:   
Bradley A. Forrest  
Reg. No. 30,837

CERTIFICATE UNDER 37 CFR 1.8: The undersigned hereby certifies that this correspondence is being filed using the USPTO's electronic filing system EFS-Web, and is addressed to: Mail Stop Amendment, Commissioner for Patents, P.O. Box 1450, Alexandria, VA 22313-1450 on this 4<sup>th</sup> day of January, 2011.

Nicole Jack

\_\_\_\_\_  
Name

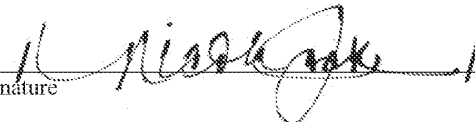
  
Signature

Under the Paperwork Reduction Act of 1995, no persons are required to respond to a collection of information unless it displays a valid OMB control number.

<b>PATENT APPLICATION FEE DETERMINATION RECORD</b> Substitute for Form PTO-875					Application or Docket Number <b>12/179,769</b>	Filing Date <b>07/25/2008</b>	<input type="checkbox"/> To be Mailed				
<b>APPLICATION AS FILED – PART I</b>					OTHER THAN						
(Column 1)		(Column 2)		SMALL ENTITY <input type="checkbox"/>		OR		SMALL ENTITY			
FOR	NUMBER FILED	NUMBER EXTRA	RATE (\$)	FEE (\$)	OR	RATE (\$)	FEE (\$)				
<input type="checkbox"/> BASIC FEE <small>(37 CFR 1.16(a), (b), or (c))</small>	N/A	N/A	N/A			N/A					
<input type="checkbox"/> SEARCH FEE <small>(37 CFR 1.16(k), (l), or (m))</small>	N/A	N/A	N/A			N/A					
<input type="checkbox"/> EXAMINATION FEE <small>(37 CFR 1.16(o), (p), or (q))</small>	N/A	N/A	N/A			N/A					
TOTAL CLAIMS <small>(37 CFR 1.16(j))</small>	minus 20 = *		X \$ =			X \$ =					
INDEPENDENT CLAIMS <small>(37 CFR 1.16(h))</small>	minus 3 = *		X \$ =			X \$ =					
<input type="checkbox"/> APPLICATION SIZE FEE <small>(37 CFR 1.16(s))</small>	If the specification and drawings exceed 100 sheets of paper, the application size fee due is \$250 (\$125 for small entity) for each additional 50 sheets or fraction thereof. See 35 U.S.C. 41(a)(1)(G) and 37 CFR 1.16(s).										
<input type="checkbox"/> MULTIPLE DEPENDENT CLAIM PRESENT <small>(37 CFR 1.16(j))</small>											
* If the difference in column 1 is less than zero, enter "0" in column 2.					TOTAL		TOTAL				
<b>APPLICATION AS AMENDED – PART II</b>					OTHER THAN						
(Column 1)		(Column 2)		(Column 3)		SMALL ENTITY		OR		SMALL ENTITY	
<b>AMENDMENT</b>	<b>01/04/2011</b>	CLAIMS REMAINING AFTER AMENDMENT		HIGHEST NUMBER PREVIOUSLY PAID FOR	PRESENT EXTRA	RATE (\$)	ADDITIONAL FEE (\$)	OR	RATE (\$)	ADDITIONAL FEE (\$)	
	Total <small>(37 CFR 1.16(j))</small>	* 17	Minus	** 20	= 0	X \$ =			X \$2=	0	
	Independent <small>(37 CFR 1.16(h))</small>	* 2	Minus	***3	= 0	X \$ =			X \$220=	0	
	<input type="checkbox"/> Application Size Fee <small>(37 CFR 1.16(s))</small>										
	<input type="checkbox"/> FIRST PRESENTATION OF MULTIPLE DEPENDENT CLAIM <small>(37 CFR 1.16(j))</small>										
					TOTAL ADD'L FEE		TOTAL ADD'L FEE	<b>0</b>			
(Column 1)		(Column 2)		(Column 3)		SMALL ENTITY		OR		SMALL ENTITY	
<b>AMENDMENT</b>		CLAIMS REMAINING AFTER AMENDMENT		HIGHEST NUMBER PREVIOUSLY PAID FOR	PRESENT EXTRA	RATE (\$)	ADDITIONAL FEE (\$)	OR	RATE (\$)	ADDITIONAL FEE (\$)	
	Total <small>(37 CFR 1.16(j))</small>	*	Minus	**	=	X \$ =			X \$ =		
	Independent <small>(37 CFR 1.16(h))</small>	*	Minus	***	=	X \$ =			X \$ =		
	<input type="checkbox"/> Application Size Fee <small>(37 CFR 1.16(s))</small>										
	<input type="checkbox"/> FIRST PRESENTATION OF MULTIPLE DEPENDENT CLAIM <small>(37 CFR 1.16(j))</small>										
					TOTAL ADD'L FEE		TOTAL ADD'L FEE				
* If the entry in column 1 is less than the entry in column 2, write "0" in column 3.					Legal Instrument Examiner: /RUTH M. LLOYD/						
** If the "Highest Number Previously Paid For" IN THIS SPACE is less than 20, enter "20".											
*** If the "Highest Number Previously Paid For" IN THIS SPACE is less than 3, enter "3".											
The "Highest Number Previously Paid For" (Total or Independent) is the highest number found in the appropriate box in column 1.											

This collection of information is required by 37 CFR 1.16. The information is required to obtain or retain a benefit by the public which is to file (and by the USPTO to process) an application. Confidentiality is governed by 35 U.S.C. 122 and 37 CFR 1.14. This collection is estimated to take 12 minutes to complete, including gathering, preparing, and submitting the completed application form to the USPTO. Time will vary depending upon the individual case. Any comments on the amount of time you require to complete this form and/or suggestions for reducing this burden, should be sent to the Chief Information Officer, U.S. Patent and Trademark Office, U.S. Department of Commerce, P.O. Box 1450, Alexandria, VA 22313-1450. DO NOT SEND FEES OR COMPLETED FORMS TO THIS ADDRESS. **SEND TO: Commissioner for Patents, P.O. Box 1450, Alexandria, VA 22313-1450.**

*If you need assistance in completing the form, call 1-800-PTO-9199 and select option 2.*



UNITED STATES PATENT AND TRADEMARK OFFICE

UNITED STATES DEPARTMENT OF COMMERCE
United States Patent and Trademark Office
Address: COMMISSIONER FOR PATENTS
P.O. Box 1450
Alexandria, Virginia 22313-1450
www.uspto.gov

NOTICE OF ALLOWANCE AND FEE(S) DUE

76287 7590 01/25/2011
SCHWEGMAN, LUNDBERG & WOESSNER / ATMEL
P.O. BOX 2938
MINNEAPOLIS, MN 55402

EXAMINER: NGUYEN, HOAI AN D
ART UNIT: 2858 PAPER NUMBER:
DATE MAILED: 01/25/2011

Table with 5 columns: APPLICATION NO., FILING DATE, FIRST NAMED INVENTOR, ATTORNEY DOCKET NO., CONFIRMATION NO.
Values: 12/179,769, 07/25/2008, Harald Philipp, 3050.030US1, 8745

TITLE OF INVENTION: PROXIMITY SENSOR

Table with 7 columns: APPLN. TYPE, SMALL ENTITY, ISSUE FEE DUE, PUBLICATION FEE DUE, PREV. PAID ISSUE FEE, TOTAL FEE(S) DUE, DATE DUE
Values: nonprovisional, NO, \$1510, \$300, \$0, \$1810, 04/25/2011

THE APPLICATION IDENTIFIED ABOVE HAS BEEN EXAMINED AND IS ALLOWED FOR ISSUANCE AS A PATENT. PROSECUTION ON THE MERITS IS CLOSED. THIS NOTICE OF ALLOWANCE IS NOT A GRANT OF PATENT RIGHTS. THIS APPLICATION IS SUBJECT TO WITHDRAWAL FROM ISSUE AT THE INITIATIVE OF THE OFFICE OR UPON PETITION BY THE APPLICANT. SEE 37 CFR 1.313 AND MPEP 1308.

THE ISSUE FEE AND PUBLICATION FEE (IF REQUIRED) MUST BE PAID WITHIN THREE MONTHS FROM THE MAILING DATE OF THIS NOTICE OR THIS APPLICATION SHALL BE REGARDED AS ABANDONED. THIS STATUTORY PERIOD CANNOT BE EXTENDED. SEE 35 U.S.C. 151. THE ISSUE FEE DUE INDICATED ABOVE DOES NOT REFLECT A CREDIT FOR ANY PREVIOUSLY PAID ISSUE FEE IN THIS APPLICATION. IF AN ISSUE FEE HAS PREVIOUSLY BEEN PAID IN THIS APPLICATION (AS SHOWN ABOVE), THE RETURN OF PART B OF THIS FORM WILL BE CONSIDERED A REQUEST TO REAPPLY THE PREVIOUSLY PAID ISSUE FEE TOWARD THE ISSUE FEE NOW DUE.

HOW TO REPLY TO THIS NOTICE:

I. Review the SMALL ENTITY status shown above.

If the SMALL ENTITY is shown as YES, verify your current SMALL ENTITY status:

- A. If the status is the same, pay the TOTAL FEE(S) DUE shown above.
B. If the status above is to be removed, check box 5b on Part B - Fee(s) Transmittal and pay the PUBLICATION FEE (if required) and twice the amount of the ISSUE FEE shown above, or

If the SMALL ENTITY is shown as NO:

- A. Pay TOTAL FEE(S) DUE shown above, or
B. If applicant claimed SMALL ENTITY status before, or is now claiming SMALL ENTITY status, check box 5a on Part B - Fee(s) Transmittal and pay the PUBLICATION FEE (if required) and 1/2 the ISSUE FEE shown above.

II. PART B - FEE(S) TRANSMITTAL, or its equivalent, must be completed and returned to the United States Patent and Trademark Office (USPTO) with your ISSUE FEE and PUBLICATION FEE (if required). If you are charging the fee(s) to your deposit account, section "4b" of Part B - Fee(s) Transmittal should be completed and an extra copy of the form should be submitted. If an equivalent of Part B is filed, a request to reapply a previously paid issue fee must be clearly made, and delays in processing may occur due to the difficulty in recognizing the paper as an equivalent of Part B.

III. All communications regarding this application must give the application number. Please direct all communications prior to issuance to Mail Stop ISSUE FEE unless advised to the contrary.

IMPORTANT REMINDER: Utility patents issuing on applications filed on or after Dec. 12, 1980 may require payment of maintenance fees. It is patentee's responsibility to ensure timely payment of maintenance fees when due.

**PART B - FEE(S) TRANSMITTAL**

**Complete and send this form, together with applicable fee(s), to: Mail Mail Stop ISSUE FEE  
 Commissioner for Patents  
 P.O. Box 1450  
 Alexandria, Virginia 22313-1450  
 or Fax (571)-273-2885**

INSTRUCTIONS: This form should be used for transmitting the ISSUE FEE and PUBLICATION FEE (if required). Blocks 1 through 5 should be completed where appropriate. All further correspondence including the Patent, advance orders and notification of maintenance fees will be mailed to the current correspondence address as indicated unless corrected below or directed otherwise in Block 1, by (a) specifying a new correspondence address; and/or (b) indicating a separate "FEE ADDRESS" for maintenance fee notifications.

CURRENT CORRESPONDENCE ADDRESS (Note: Use Block 1 for any change of address)

76287 7590 01/25/2011

SCHWEGMAN, LUNDBERG & WOESSNER / ATMEL  
 P.O. BOX 2938  
 MINNEAPOLIS, MN 55402

Note: A certificate of mailing can only be used for domestic mailings of the Fee(s) Transmittal. This certificate cannot be used for any other accompanying papers. Each additional paper, such as an assignment or formal drawing, must have its own certificate of mailing or transmission.

**Certificate of Mailing or Transmission**

I hereby certify that this Fee(s) Transmittal is being deposited with the United States Postal Service with sufficient postage for first class mail in an envelope addressed to the Mail Stop ISSUE FEE address above, or being facsimile transmitted to the USPTO (571) 273-2885, on the date indicated below.

_____ (Depositor's name)
_____ (Signature)
_____ (Date)

APPLICATION NO.	FILING DATE	FIRST NAMED INVENTOR	ATTORNEY DOCKET NO.	CONFIRMATION NO.
12/179,769	07/25/2008	Harald Philipp	3050.030U1	8745

TITLE OF INVENTION: PROXIMITY SENSOR

APPLN. TYPE	SMALL ENTITY	ISSUE FEE DUE	PUBLICATION FEE DUE	PREV. PAID ISSUE FEE	TOTAL FEE(S) DUE	DATE DUE
nonprovisional	NO	\$1510	\$300	\$0	\$1810	04/25/2011

EXAMINER	ART UNIT	CLASS-SUBCLASS
NGUYEN, HOAI AN D	2858	324-663000

<p>1. Change of correspondence address or indication of "Fee Address" (37 CFR 1.363).</p> <p><input type="checkbox"/> Change of correspondence address (or Change of Correspondence Address form PTO/SB/122) attached.</p> <p><input type="checkbox"/> "Fee Address" indication (or "Fee Address" Indication form PTO/SB/47; Rev 03-02 or more recent) attached. <b>Use of a Customer Number is required.</b></p>	<p>2. For printing on the patent front page, list</p> <p>(1) the names of up to 3 registered patent attorneys or agents OR, alternatively, _____ 1 _____</p> <p>(2) the name of a single firm (having as a member a registered attorney or agent) and the names of up to 2 registered patent attorneys or agents. If no name is listed, no name will be printed. _____ 2 _____</p> <p>_____ 3 _____</p>
---	---

3. ASSIGNEE NAME AND RESIDENCE DATA TO BE PRINTED ON THE PATENT (print or type)

PLEASE NOTE: Unless an assignee is identified below, no assignee data will appear on the patent. If an assignee is identified below, the document has been filed for recordation as set forth in 37 CFR 3.11. Completion of this form is NOT a substitute for filing an assignment.

(A) NAME OF ASSIGNEE \_\_\_\_\_ (B) RESIDENCE: (CITY and STATE OR COUNTRY) \_\_\_\_\_

Please check the appropriate assignee category or categories (will not be printed on the patent):  Individual  Corporation or other private group entity  Government

<p>4a. The following fee(s) are submitted:</p> <p><input type="checkbox"/> Issue Fee</p> <p><input type="checkbox"/> Publication Fee (No small entity discount permitted)</p> <p><input type="checkbox"/> Advance Order - # of Copies _____</p>	<p>4b. Payment of Fee(s): (Please first reapply any previously paid issue fee shown above)</p> <p><input type="checkbox"/> A check is enclosed.</p> <p><input type="checkbox"/> Payment by credit card. Form PTO-2038 is attached.</p> <p><input type="checkbox"/> The Director is hereby authorized to charge the required fee(s), any deficiency, or credit any overpayment, to Deposit Account Number _____ (enclose an extra copy of this form).</p>
---	--

5. Change in Entity Status (from status indicated above)

a. Applicant claims SMALL ENTITY status. See 37 CFR 1.27.  b. Applicant is no longer claiming SMALL ENTITY status. See 37 CFR 1.27(g)(2).

NOTE: The Issue Fee and Publication Fee (if required) will not be accepted from anyone other than the applicant; a registered attorney or agent; or the assignee or other party in interest as shown by the records of the United States Patent and Trademark Office.

Authorized Signature \_\_\_\_\_ Date \_\_\_\_\_

Typed or printed name \_\_\_\_\_ Registration No. \_\_\_\_\_

This collection of information is required by 37 CFR 1.311. The information is required to obtain or retain a benefit by the public which is to file (and by the USPTO to process) an application. Confidentiality is governed by 35 U.S.C. 122 and 37 CFR 1.14. This collection is estimated to take 12 minutes to complete, including gathering, preparing, and submitting the completed application form to the USPTO. Time will vary depending upon the individual case. Any comments on the amount of time you require to complete this form and/or suggestions for reducing this burden, should be sent to the Chief Information Officer, U.S. Patent and Trademark Office, U.S. Department of Commerce, P.O. Box 1450, Alexandria, Virginia 22313-1450. DO NOT SEND FEES OR COMPLETED FORMS TO THIS ADDRESS. SEND TO: Commissioner for Patents, P.O. Box 1450, Alexandria, Virginia 22313-1450.

Under the Paperwork Reduction Act of 1995, no persons are required to respond to a collection of information unless it displays a valid OMB control number.



UNITED STATES PATENT AND TRADEMARK OFFICE

UNITED STATES DEPARTMENT OF COMMERCE
United States Patent and Trademark Office
Address: COMMISSIONER FOR PATENTS
P.O. Box 1450
Alexandria, Virginia 22313-1450
www.uspto.gov

Table with columns: APPLICATION NO., FILING DATE, FIRST NAMED INVENTOR, ATTORNEY DOCKET NO., CONFIRMATION NO.
12/179,769 07/25/2008 Harald Philipp 3050.030US1 8745
76287 7590 01/25/2011
SCHWEGMAN, LUNDBERG & WOESSNER / ATMEL
P.O. BOX 2938
MINNEAPOLIS, MN 55402
EXAMINER NGUYEN, HOAI AN D
ART UNIT 2858 PAPER NUMBER
DATE MAILED: 01/25/2011

Determination of Patent Term Adjustment under 35 U.S.C. 154 (b)
(application filed on or after May 29, 2000)

The Patent Term Adjustment to date is 374 day(s). If the issue fee is paid on the date that is three months after the mailing date of this notice and the patent issues on the Tuesday before the date that is 28 weeks (six and a half months) after the mailing date of this notice, the Patent Term Adjustment will be 374 day(s).

If a Continued Prosecution Application (CPA) was filed in the above-identified application, the filing date that determines Patent Term Adjustment is the filing date of the most recent CPA.

Applicant will be able to obtain more detailed information by accessing the Patent Application Information Retrieval (PAIR) WEB site (http://pair.uspto.gov).

Any questions regarding the Patent Term Extension or Adjustment determination should be directed to the Office of Patent Legal Administration at (571)-272-7702. Questions relating to issue and publication fee payments should be directed to the Customer Service Center of the Office of Patent Publication at 1-(888)-786-0101 or (571)-272-4200.

<b>Notice of Allowability</b>	<b>Application No.</b> 12/179,769	<b>Applicant(s)</b> PHILIPP ET AL.	
	<b>Examiner</b> HOAI-AN D. NGUYEN	<b>Art Unit</b> 2858	

**-- The MAILING DATE of this communication appears on the cover sheet with the correspondence address--**

All claims being allowable, PROSECUTION ON THE MERITS IS (OR REMAINS) CLOSED in this application. If not included herewith (or previously mailed), a Notice of Allowance (PTOL-85) or other appropriate communication will be mailed in due course. **THIS NOTICE OF ALLOWABILITY IS NOT A GRANT OF PATENT RIGHTS.** This application is subject to withdrawal from issue at the initiative of the Office or upon petition by the applicant. See 37 CFR 1.313 and MPEP 1308.

1.  This communication is responsive to the Amendment filed on January 4, 2011.
2.  The allowed claim(s) is/are 1, 5, 6 and 8-21.
3.  Acknowledgment is made of a claim for foreign priority under 35 U.S.C. § 119(a)-(d) or (f).
  - a)  All    b)  Some\*    c)  None    of the:
    1.  Certified copies of the priority documents have been received.
    2.  Certified copies of the priority documents have been received in Application No. \_\_\_\_\_.
    3.  Copies of the certified copies of the priority documents have been received in this national stage application from the International Bureau (PCT Rule 17.2(a)).

\* Certified copies not received: \_\_\_\_\_.

Applicant has THREE MONTHS FROM THE "MAILING DATE" of this communication to file a reply complying with the requirements noted below. Failure to timely comply will result in ABANDONMENT of this application.  
**THIS THREE-MONTH PERIOD IS NOT EXTENDABLE.**

4.  A SUBSTITUTE OATH OR DECLARATION must be submitted. Note the attached EXAMINER'S AMENDMENT or NOTICE OF INFORMAL PATENT APPLICATION (PTO-152) which gives reason(s) why the oath or declaration is deficient.
5.  CORRECTED DRAWINGS ( as "replacement sheets") must be submitted.
  - (a)  including changes required by the Notice of Draftsperson's Patent Drawing Review ( PTO-948) attached
    - 1)  hereto or 2)  to Paper No./Mail Date \_\_\_\_\_.
  - (b)  including changes required by the attached Examiner's Amendment / Comment or in the Office action of Paper No./Mail Date \_\_\_\_\_.

**Identifying indicia such as the application number (see 37 CFR 1.84(c)) should be written on the drawings in the front (not the back) of each sheet. Replacement sheet(s) should be labeled as such in the header according to 37 CFR 1.121(d).**
6.  DEPOSIT OF and/or INFORMATION about the deposit of BIOLOGICAL MATERIAL must be submitted. Note the attached Examiner's comment regarding REQUIREMENT FOR THE DEPOSIT OF BIOLOGICAL MATERIAL.

**Attachment(s)**

- |  |  |
|--|--|
| 1. <input type="checkbox"/> Notice of References Cited (PTO-892)   | 5. <input type="checkbox"/> Notice of Informal Patent Application                      |
| 2. <input type="checkbox"/> Notice of Draftsperson's Patent Drawing Review (PTO-948)                       | 6. <input type="checkbox"/> Interview Summary (PTO-413),<br>Paper No./Mail Date _____. |
| 3. <input type="checkbox"/> Information Disclosure Statements (PTO/SB/08),<br>Paper No./Mail Date _____    | 7. <input type="checkbox"/> Examiner's Amendment/Comment                               |
| 4. <input type="checkbox"/> Examiner's Comment Regarding Requirement for Deposit<br>of Biological Material | 8. <input checked="" type="checkbox"/> Examiner's Statement of Reasons for Allowance   |
|  | 9. <input type="checkbox"/> Other _____.   |

--	--

**DETAILED ACTION**

1. Receipt is acknowledged of the Amendment filed on January 4, 2011. Claims 2-4, 7, 22 and 23 are cancelled; and claims 1, 5, 6 and 8-21 are pending in the application.

**Allowable Subject Matter**

2. Claims 1, 5, 6 and 8-21 are allowed.

3. The following is an examiner's statement of reasons for allowance:

With regard to claim 1, applicants' arguments in the fifth paragraph at page 7 of the Remarks and amendments have been considered and found persuasive. The prior art does not teach, suggest or render obvious the claimed sensor for determining the presence of an object in combination as claimed including:

- The control circuit includes a time input terminal and the predetermined time duration is selectable from the number of different predefined time durations according to a voltage applied to the time input terminal; and
- The control circuit includes a delay multiplier terminal and is configured so that a selected one of the number of different predefined time durations is multiplied by a multiplication factor according to a voltage applied to the delay multiplier terminal to provide the predetermined time duration.

With regard to claims 8-21, these claims are allowed at least by virtue of their dependencies directly or indirectly from the base claim.

With regard to claim 5, applicants' arguments in the fifth paragraph at page 7 of the Remarks and amendments have been considered and found persuasive. The prior art does not teach, suggest or render obvious the claimed sensor for determining the presence of an object in combination as claimed including:

- The control circuit is configured so that the predetermined time duration is programmable by a user to provide a user-selected time duration; and
- The control circuit includes a delay multiplier terminal and is configured so that the user-selected time duration is multiplied by a multiplication factor according to a voltage applied to the delay multiplier terminal to provide the predetermined time duration.

With regard to claim 6, this claim is allowed at least by virtue of its dependency from the base claim.

Any comments considered necessary by applicant must be submitted no later than the payment of the issue fee and, to avoid processing delays, should preferably accompany the issue fee. Such submissions should be clearly labeled "Comments on Statement of Reasons for Allowance."

#### **CONTACT INFORMATION**

Any inquiry concerning this communication or earlier communications from the examiner should be directed to HOAI-AN D. NGUYEN whose telephone number is (571)-272-2170. The examiner can normally be reached on MON-THURS. (7:15 - 5:45).



Application/Control Number: 12/179,769  
Art Unit: 2858

Page 4

If attempts to reach the examiner by telephone are unsuccessful, the examiner's supervisor, Melissa J. Koval can be reached on (571)-272-2121. The fax phone number for the organization where this application or proceeding is assigned is 571-273-8300.

Information regarding the status of an application may be obtained from the Patent Application Information Retrieval (PAIR) system. Status information for published applications may be obtained from either Private PAIR or Public PAIR. Status information for unpublished applications is available through Private PAIR only. For more information about the PAIR system, see <http://pair-direct.uspto.gov>. Should you have questions on access to the Private PAIR system, contact the Electronic Business Center (EBC) at 866-217-9197 (toll-free). If you would like assistance from a USPTO Customer Service Representative or access to the automated information system, call 800-786-9199 (IN USA OR CANADA) or 571-272-1000.

Hoai-An D. Nguyen  
Primary Examiner  
Art Unit 2858

/Hoai-An D. Nguyen/  
Primary Examiner, Art Unit 2858

<b>Index of Claims</b> 	<b>Application/Control No.</b> 12179769	<b>Applicant(s)/Patent Under Reexamination</b> PHILIPP ET AL.
	<b>Examiner</b> HOAI-AN D NGUYEN	<b>Art Unit</b> 2831

✓	<b>Rejected</b>	-	<b>Cancelled</b>	N	<b>Non-Elected</b>	A	<b>Appeal</b>
=	<b>Allowed</b>	÷	<b>Restricted</b>	I	<b>Interference</b>	O	<b>Objected</b>

Claims renumbered in the same order as presented by applicant
  CPA
  T.D.
  R.1.47

CLAIM		DATE							
Final	Original	01/16/2011							
1	1	=							
	2	-							
	3	-							
	4	-							
16	5	=							
17	6	=							
	7	-							
8	8	=							
9	9	=							
10	10	=							
11	11	=							
12	12	=							
13	13	=							
14	14	=							
15	15	=							
2	16	=							
3	17	=							
4	18	=							
5	19	=							
6	20	=							
7	21	=							
	22	-							
	23	-							

<b>Issue Classification</b> 	<b>Application/Control No.</b> 12179769	<b>Applicant(s)/Patent Under Reexamination</b> PHILIPP ET AL.
	<b>Examiner</b> HOAI-AN D NGUYEN	<b>Art Unit</b> 2858

ORIGINAL						INTERNATIONAL CLASSIFICATION														
CLASS			SUBCLASS			CLAIMED					NON-CLAIMED									
324			663			G	0	1	R	27 / 26 (2006.01.01)										
CROSS REFERENCE(S)						G	0	8	B	13 / 08 (2006.01.01)										
CLASS	SUBCLASS (ONE SUBCLASS PER BLOCK)																			
340	545.4																			

Claims renumbered in the same order as presented by applicant
  CPA
  T.D.
  R.1.47

Final	Original	Final	Original	Final	Original	Final	Original	Final	Original	Final	Original	Final	Original	Final	Original
1	1	3	17												
-	2	4	18												
-	3	5	19												
-	4	6	20												
16	5	7	21												
17	6	-	22												
-	7	-	23												
8	8														
9	9														
10	10														
11	11														
12	12														
13	13														
14	14														
15	15														
2	16														

NONE	<b>Total Claims Allowed:</b>	
(Assistant Examiner)	(Date)	17
/HOAI-AN D NGUYEN/ Primary Examiner.Art Unit 2858	01/16/2011	O.G. Print Claim(s)    O.G. Print Figure
(Primary Examiner)	(Date)	1                                    1

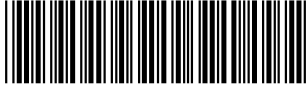
<b>Search Notes</b> 	<b>Application/Control No.</b> 12/179,769	<b>Applicant(s)/Patent under Reexamination</b> PHILIPP ET AL.	
	<b>Examiner</b> HOAI-AN D. NGUYEN	<b>Art Unit</b> 2858	

SEARCHED			
Class	Subclass	Date	Examiner
Updated	previously searched areas.	1/14/2011	HADN
324	663	1/14/2011	HADN
324	658	1/14/2011	HADN
324	649	1/14/2011	HADN
324	600	1/14/2011	HADN
702	57	1/14/2011	HADN
340	545.4	1/16/2011	HADN

INTERFERENCE SEARCHED			
Class	Subclass	Date	Examiner
Interference Search History Printout.		1/16/2011	HADN

SEARCH NOTES (INCLUDING SEARCH STRATEGY)		
	DATE	EXMR
Reviewed all previously searched prior art references.	1/14/2011	HADN
Text search in 340/545.1, 541 and 540.	1/16/2011	HADN
Text search in EAST.	1/16/2011	HADN
Inventors' names searched.	1/16/2011	HADN

**UNITED STATES PATENT AND TRADEMARK OFFICE**

UNITED STATES DEPARTMENT OF COMMERCE  
 United States Patent and Trademark Office  
 Address: COMMISSIONER FOR PATENTS  
 P.O. Box 1450  
 Alexandria, Virginia 22313-1450  
 www.uspto.gov

**BIB DATA SHEET**
**CONFIRMATION NO. 8745**

SERIAL NUMBER	FILING or 371(c) DATE	CLASS	GROUP ART UNIT	ATTORNEY DOCKET NO.	
12/179,769	07/25/2008	324	2858	3050.030US1	
<b>APPLICANTS</b> Harald Philipp, Southampton, UNITED KINGDOM; Kevin Snoad, Chicester, UNITED KINGDOM; <b>** CONTINUING DATA *****</b> This appln claims benefit of 60/952,053 07/26/2007 <b>** FOREIGN APPLICATIONS *****</b> <b>** IF REQUIRED, FOREIGN FILING LICENSE GRANTED **</b> 08/01/2008					
Foreign Priority claimed <input type="checkbox"/> Yes <input checked="" type="checkbox"/> No 35 USC 119(a-d) conditions met <input type="checkbox"/> Yes <input checked="" type="checkbox"/> No Verified and /HOAI-AN D Acknowledged NGUYEN/ Examiner's Signature	<input type="checkbox"/> Met after Allowance Initials	<b>STATE OR COUNTRY</b> UNITED KINGDOM	<b>SHEETS DRAWINGS</b> 10	<b>TOTAL CLAIMS</b> <del>23</del> 17	<b>INDEPENDENT CLAIMS</b> 2
<b>ADDRESS</b> SCHWEGMAN, LUNDBERG & WOESSNER / ATMEL P.O. BOX 2938 MINNEAPOLIS, MN 55402 UNITED STATES					
<b>TITLE</b> Proximity Sensor					
<b>FILING FEE RECEIVED</b> 1310	FEES: Authority has been given in Paper No. _____ to charge/credit DEPOSIT ACCOUNT No. _____ for following:		<input type="checkbox"/> All Fees <input type="checkbox"/> 1.16 Fees (Filing) <input type="checkbox"/> 1.17 Fees (Processing Ext. of time) <input type="checkbox"/> 1.18 Fees (Issue) <input type="checkbox"/> Other _____ <input type="checkbox"/> Credit		

## EAST Search History

## EAST Search History (Prior Art)

Ref #	Hits	Search Query	DBs	Default Operator	Plurals	Time Stamp
L3	51	(340/545.4.ccls.) and @ad<"20080722"	US-PGPUB; USPAT; USOCR; FPRS; EPO; JPO; DERWENT; IBM_TDB	OR	ON	2011/01/16 10:00
L4	134	(340/545.2.ccls.) and @ad<"20080722"	US-PGPUB; USPAT; USOCR; FPRS; EPO; JPO; DERWENT; IBM_TDB	OR	ON	2011/01/16 10:03
L5	522	(340/545.1.ccls.) and @ad<"20080722"	US-PGPUB; USPAT; USOCR; FPRS; EPO; JPO; DERWENT; IBM_TDB	OR	ON	2011/01/16 10:03
L6	1833	(340/541.ccls.) and @ad<"20080722"	US-PGPUB; USPAT; USOCR; FPRS; EPO; JPO; DERWENT; IBM_TDB	OR	ON	2011/01/16 10:03
L7	2020	(340/540.ccls.) and @ad<"20080722"	US-PGPUB; USPAT; USOCR; FPRS; EPO; JPO; DERWENT; IBM_TDB	OR	ON	2011/01/16 10:03
L8	8	l3 and ((check\$3 detect\$3 sens\$3 examin\$3 determin\$3 recogniz\$3 inspect\$3 analy\$4 anali\$4 monitor\$3 diagnos\$3 identif\$4 record\$3 judg\$3 find\$3 indicat\$3 verif\$4 captur\$3) near2 (presen\$3 absen\$3 exist\$5 proximity appearance) near2 (user object person body target finger subject member element structure cable wire component conductor human occupancy human driver operator occupancy occup\$5))	US-PGPUB; USPAT; USOCR; FPRS; EPO; JPO; DERWENT; IBM_TDB	OR	ON	2011/01/16 10:04

L9	21	l4 and ((check\$3 detect\$3 sens\$3 examin\$3 determin\$3 recogniz\$3 inspect\$3 analy\$4 anali\$4 monitor\$3 diagnos\$3 identif\$4 record\$3 judg\$3 find\$3 indicat\$3 verif\$4 captur\$3) near2 (presen\$3 absen\$3 exist\$5 proximity appearance) near2 (user object person body target finger subject member element structure cable wire component conductor human occupancy human driver operator occupancy occup\$5))	US-PGPUB; USPAT; USOCR; FPRS; EPO; JPO; DERWENT; IBM_TDB	OR	ON	2011/01/16 10:05
L10	83	l5 and ((check\$3 detect\$3 sens\$3 examin\$3 determin\$3 recogniz\$3 inspect\$3 analy\$4 anali\$4 monitor\$3 diagnos\$3 identif\$4 record\$3 judg\$3 find\$3 indicat\$3 verif\$4 captur\$3) near2 (presen\$3 absen\$3 exist\$5 proximity appearance) near2 (user object person body target finger subject member element structure cable wire component conductor human occupancy human driver operator occupancy occup\$5))	US-PGPUB; USPAT; USOCR; FPRS; EPO; JPO; DERWENT; IBM_TDB	OR	ON	2011/01/16 10:09
L11	377	l6 and ((check\$3 detect\$3 sens\$3 examin\$3 determin\$3 recogniz\$3 inspect\$3 analy\$4 anali\$4 monitor\$3 diagnos\$3 identif\$4 record\$3 judg\$3 find\$3 indicat\$3 verif\$4 captur\$3) near2 (presen\$3 absen\$3 exist\$5 proximity appearance) near2 (user object person body target finger subject member element structure cable wire component conductor human occupancy human driver operator occupancy occup\$5))	US-PGPUB; USPAT; USOCR; FPRS; EPO; JPO; DERWENT; IBM_TDB	OR	ON	2011/01/16 10:09

L12	6	l8 and (check\$3 detect\$3 sens\$3 measur\$3 comput\$3 calculat\$3 \$2valuat\$3 examin\$3 test\$3 determin\$3 recogniz\$3 inspect\$3 analy\$4 anali\$4 monitor\$3 diagnos\$3 identif\$4 record\$3 meter\$3 gaug\$3 judg\$3 find\$3 indicat\$3 verif\$4 captur\$3) near2 capacitance	US-PGPUB; USPAT; USOCR; FPRS; EPO; JPO; DERWENT; IBM_TDB	OR	ON	2011/01/16 10:10
L13	4	l9 and (check\$3 detect\$3 sens\$3 measur\$3 comput\$3 calculat\$3 \$2valuat\$3 examin\$3 test\$3 determin\$3 recogniz\$3 inspect\$3 analy\$4 anali\$4 monitor\$3 diagnos\$3 identif\$4 record\$3 meter\$3 gaug\$3 judg\$3 find\$3 indicat\$3 verif\$4 captur\$3) near2 capacitance	US-PGPUB; USPAT; USOCR; FPRS; EPO; JPO; DERWENT; IBM_TDB	OR	ON	2011/01/16 10:10
L14	8	l10 and (check\$3 detect\$3 sens\$3 measur\$3 comput\$3 calculat\$3 \$2valuat\$3 examin\$3 test\$3 determin\$3 recogniz\$3 inspect\$3 analy\$4 anali\$4 monitor\$3 diagnos\$3 identif\$4 record\$3 meter\$3 gaug\$3 judg\$3 find\$3 indicat\$3 verif\$4 captur\$3) near2 capacitance	US-PGPUB; USPAT; USOCR; FPRS; EPO; JPO; DERWENT; IBM_TDB	OR	ON	2011/01/16 10:11
L15	17	l11 and (check\$3 detect\$3 sens\$3 measur\$3 comput\$3 calculat\$3 \$2valuat\$3 examin\$3 test\$3 determin\$3 recogniz\$3 inspect\$3 analy\$4 anali\$4 monitor\$3 diagnos\$3 identif\$4 record\$3 meter\$3 gaug\$3 judg\$3 find\$3 indicat\$3 verif\$4 captur\$3) near2 capacitance	US-PGPUB; USPAT; USOCR; FPRS; EPO; JPO; DERWENT; IBM_TDB	OR	ON	2011/01/16 10:11



L16	4	l12 and ((check\$3 detect\$3 sens\$3 examin\$3 determin\$3 recogniz\$3 inspect\$3 analy\$4 anali\$4 monitor\$3 diagnos\$3 identif\$4 record\$3 judg\$3 find\$3 indicat\$3 verif\$4 captur\$3) near2 (presen\$3 absen\$3 exist\$5 proximity appearance) near2 (user object person body target finger subject member element structure cable wire component conductor human occupancy human driver operator occupancy occup\$5)) with capacitance	US-PGPUB; USPAT; USOCR; FPRS; EPO; JPO; DERWENT; IBM_TDB	OR	ON	2011/01/16 10:12
L17	1	l13 and ((check\$3 detect\$3 sens\$3 examin\$3 determin\$3 recogniz\$3 inspect\$3 analy\$4 anali\$4 monitor\$3 diagnos\$3 identif\$4 record\$3 judg\$3 find\$3 indicat\$3 verif\$4 captur\$3) near2 (presen\$3 absen\$3 exist\$5 proximity appearance) near2 (user object person body target finger subject member element structure cable wire component conductor human occupancy human driver operator occupancy occup\$5)) with capacitance	US-PGPUB; USPAT; USOCR; FPRS; EPO; JPO; DERWENT; IBM_TDB	OR	ON	2011/01/16 10:13
L18	0	l14 and ((check\$3 detect\$3 sens\$3 examin\$3 determin\$3 recogniz\$3 inspect\$3 analy\$4 anali\$4 monitor\$3 diagnos\$3 identif\$4 record\$3 judg\$3 find\$3 indicat\$3 verif\$4 captur\$3) near2 (presen\$3 absen\$3 exist\$5 proximity appearance) near2 (user object person body target finger subject member element structure cable wire component conductor human occupancy human driver operator occupancy occup\$5)) with capacitance	US-PGPUB; USPAT; USOCR; FPRS; EPO; JPO; DERWENT; IBM_TDB	OR	ON	2011/01/16 10:23

L19	3	l15 and ((check\$3 detect\$3 sens\$3 examin\$3 determin\$3 recogniz\$3 inspect\$3 analy\$4 anali\$4 monitor\$3 diagnos\$3 identif\$4 record\$3 judg\$3 find\$3 indicat\$3 verif\$4 captur\$3) near2 (presen\$3 absen\$3 exist\$5 proximity appearance) near2 (user object person body target finger subject member element structure cable wire component conductor human occupancy human driver operator occupancy occup\$5)) with capacitance	US-PGPUB; USPAT; USOCR; FPRS; EPO; JPO; DERWENT; IBM_TDB	OR	ON	2011/01/16 10:24
L20	521	(381/74.ccls.) and @ad<"20080722"	US-PGPUB; USPAT; USOCR; FPRS; EPO; JPO; DERWENT; IBM_TDB	OR	ON	2011/01/16 10:25
L21	12	l20 and ((check\$3 detect\$3 sens\$3 examin\$3 determin\$3 recogniz\$3 inspect\$3 analy\$4 anali\$4 monitor\$3 diagnos\$3 identif\$4 record\$3 judg\$3 find\$3 indicat\$3 verif\$4 captur\$3) near2 (presen\$3 absen\$3 exist\$5 proximity appearance) near2 (user object person body target finger subject member element structure cable wire component conductor human occupancy human driver operator occupancy occup\$5))	US-PGPUB; USPAT; USOCR; FPRS; EPO; JPO; DERWENT; IBM_TDB	OR	ON	2011/01/16 10:29
L22	3	l21 and (check\$3 detect\$3 sens\$3 measur\$3 comput\$3 calculat\$3 \$2valuat\$3 examin\$3 test\$3 determin\$3 recogniz\$3 inspect\$3 analy\$4 anali\$4 monitor\$3 diagnos\$3 identif\$4 record\$3 meter\$3 gaug\$3 judg\$3 find\$3 indicat\$3 verif\$4 captur\$3) near2 capacitance	US-PGPUB; USPAT; USOCR; FPRS; EPO; JPO; DERWENT; IBM_TDB	OR	ON	2011/01/16 10:30

L23	148	((Philipp near2 Harald) (Snoad near2 Kevin)).inv.	US-PGPUB; USPAT; USOCR; FPRS; EPO; JPO; DERWENT; IBM_TDB	OR	ON	2011/01/16 10:42
L24	50	l23 and ((check\$3 detect\$3 sens\$3 examin\$3 determin \$3 recogniz\$3 inspect\$3 analy\$4 anali\$4 monitor\$3 diagnos\$3 identif\$4 record \$3 judg\$3 find\$3 indicat\$3 verif\$4 captur\$3) near2 (presen\$3 absen\$3 exist\$5 proximity appearance) near2 (user object person body target finger subject member element structure cable wire component conductor human occupancy human driver operator occupancy occup \$5))	US-PGPUB; USPAT; USOCR; FPRS; EPO; JPO; DERWENT; IBM_TDB	OR	ON	2011/01/16 10:42
L25	44	l24 and (check\$3 detect\$3 sens\$3 measur\$3 comput \$3 calculat\$3 \$2valuat\$3 examin\$3 test\$3 determin \$3 recogniz\$3 inspect\$3 analy\$4 anali\$4 monitor\$3 diagnos\$3 identif\$4 record \$3 meter\$3 gaug\$3 judg\$3 find\$3 indicat\$3 verif\$4 captur\$3) near2 capacitance	US-PGPUB; USPAT; USOCR; FPRS; EPO; JPO; DERWENT; IBM_TDB	OR	ON	2011/01/16 10:43
L26	30	l25 and ((check\$3 detect\$3 sens\$3 examin\$3 determin \$3 recogniz\$3 inspect\$3 analy\$4 anali\$4 monitor\$3 diagnos\$3 identif\$4 record \$3 judg\$3 find\$3 indicat\$3 verif\$4 captur\$3) near2 (presen\$3 absen\$3 exist\$5 proximity appearance) near2 (user object person body target finger subject member element structure cable wire component conductor human occupancy human driver operator occupancy occup \$5)) with capacitance	US-PGPUB; USPAT; USOCR; FPRS; EPO; JPO; DERWENT; IBM_TDB	OR	ON	2011/01/16 10:44

L35	7	<p>(((check\$3 detect\$3 sens\$3 examin\$3 determin\$3 recogniz\$3 inspect\$3 analy\$4 anali\$4 monitor\$3 diagnos\$3 identif\$4 record\$3 judg\$3 find\$3 indicat\$3 verif\$4 captur\$3) near2 (presen\$3 absen\$3 exist\$5 proximity appearance) near2 (user object person body target finger subject member element structure cable wire component conductor human occupancy human driver operator occupancy occup\$5)) with capacitance) and ((check\$3 detect\$3 sens\$3 measur\$3 comput\$3 calculat\$3 \$2valuat\$3 examin\$3 test\$3 determin\$3 recogniz\$3 inspect\$3 analy\$4 anali\$4 monitor\$3 diagnos\$3 identif\$4 record\$3 meter\$3 gaug\$3 judg\$3 find\$3 indicat\$3 verif\$4 captur\$3) near2 capacitance) and ((presen\$3 absen\$3 exist\$5 proximity appearance) near2 (object person body target finger subject member element structure cable wire component conductor human occupancy human driver operator occupancy occup\$5)) with ((pre\$1select\$3 pre\$1determin\$3 pre\$1defin\$3 specif\$5 pre\$1set\$4 maximum minimum limit threshold reference desir\$5 expected wanted standard known model second spare bench\$1mark stored) near2 time near2 (period interval cycle duration shift relay range band block))) and @ad&lt;"20080722"</p>	<p>US-PGPUB; USPAT; USOCR; FPRS; EPO; JPO; DERWENT; IBM_TDB</p>	OR	ON	<p>2011/01/16 13:49</p>
-----	---	--	---	----	----	-----------------------------

L36	27	<p>(((check\$3 detect\$3 sens\$3 examin\$3 determin\$3 recogniz\$3 inspect\$3 analy\$4 anali\$4 monitor\$3 diagnos\$3 identif\$4 record\$3 judg\$3 find\$3 indicat\$3 verif\$4 captur\$3) near2 (presen\$3 absen\$3 exist\$5 proximity appearance) near2 (user object person body target finger subject member element structure cable wire component conductor human occupancy human driver operator occupancy occup\$5)) and ((check\$3 detect\$3 sens\$3 measur\$3 comput\$3 calculat\$3 \$2valuat\$3 examin\$3 test\$3 determin\$3 recogniz\$3 inspect\$3 analy\$4 anali\$4 monitor\$3 diagnos\$3 identif\$4 record\$3 meter\$3 gaug\$3 judg\$3 find\$3 indicat\$3 verif\$4 captur\$3) near2 capacitance) and ((presen\$3 absen\$3 exist\$5 proximity appearance) near2 (object person body target finger subject member element structure cable wire component conductor human occupancy human driver operator occupancy occup\$5)) with ((pre\$1select\$3 pre\$1determin\$3 pre\$1defin\$3 specif\$5 pre\$1set\$4 maximum minimum limit threshold reference desir\$5 expected wanted standard known model second spare bench\$1mark stored) near2 time near2 (period interval cycle duration shift relay range band block))) and @ad&lt;"20080722"</p>	<p>US-PGPUB; USPAT; USOCR; FPRS; EPO; JPO; DERWENT; IBM_TDB</p>	OR	ON	<p>2011/01/16 13:53</p>
-----	----	--	---	----	----	-----------------------------

S69	7	(324/663.ccls.) and @ad<"20080722" and @pd>"20100927"	US-PGPUB; USPAT; USOCR; FPRS; EPO; JPO; DERWENT; IBM_TDB	OR	ON	2011/01/14 15:19
S70	13	(324/658.ccls.) and @ad<"20080722" and @pd>"20100927"	US-PGPUB; USPAT; USOCR; FPRS; EPO; JPO; DERWENT; IBM_TDB	OR	ON	2011/01/14 15:19
S71	2	(324/649.ccls.) and @ad<"20080722" and @pd>"20100927"	US-PGPUB; USPAT; USOCR; FPRS; EPO; JPO; DERWENT; IBM_TDB	OR	ON	2011/01/14 15:20
S72	6	(324/600.ccls.) and @ad<"20080722" and @pd>"20100927"	US-PGPUB; USPAT; USOCR; FPRS; EPO; JPO; DERWENT; IBM_TDB	OR	ON	2011/01/14 15:20
S73	17	(702/57.ccls.) and @ad<"20080722" and @pd>"20100927"	US-PGPUB; USPAT; USOCR; FPRS; EPO; JPO; DERWENT; IBM_TDB	OR	ON	2011/01/14 15:20

**EAST Search History (Interference)**

Ref #	Hits	Search Query	DBs	Default Operator	Plurals	Time Stamp
L27	2	(((check\$3 detect\$3 sens\$3 examin\$3 determin\$3 recogniz\$3 inspect\$3 analy\$4 anali\$4 monitor\$3 diagnos\$3 identif\$4 record\$3 judg\$3 find\$3 indicat\$3 verif\$4 captur\$3) near2 (presen\$3 absen\$3 exist\$5 proximity appearance) near2 (user object person body target finger subject member element structure cable wire component conductor human occupancy human driver operator occupancy occup\$5)) with capacitance) and	US-PGPUB; USPAT; UPAD	OR	ON	2011/01/16 11:18

		((check\$3 detect\$3 sens\$3 measur\$3 comput\$3 calculat\$3 \$2valuat\$3 examin\$3 test\$3 determin\$3 recogniz\$3 inspect\$3 analy\$4 anali\$4 monitor\$3 diagnos\$3 identif\$4 record\$3 meter\$3 gaug\$3 judg\$3 find\$3 indicat\$3 verif\$4 captur\$3) near2 capacitance) and ((presen\$3 absen\$3 exist\$5 proximity appearance) near2 (object person body target finger subject member element structure cable wire component conductor human occupancy human driver operator occupancy occup\$5)) with ((pre\$1select\$3 pre\$1determin\$3 pre\$1defin\$3 specif\$5 pre\$1set\$4 maximum minimum limit threshold reference desir\$5 expected wanted standard known model second spare bench \$1mark stored) near2 time near2 (period interval cycle duration shift relay range band block))).clm.				
L28	4	((check\$3 detect\$3 sens\$3 examin\$3 determin\$3 recogniz\$3 inspect\$3 analy\$4 anali\$4 monitor\$3 diagnos\$3 identif\$4 record\$3 judg\$3 find\$3 indicat\$3 verif\$4 captur\$3) near2 (presen\$3 absen\$3 exist\$5 proximity appearance) near2 (user object person body target finger subject member element structure cable wire	US-PGPUB; USPAT; UPAD	OR	ON	2011/01/16 11:21

component conductor  
human occupancy  
human driver operator  
occupancy occup\$5))  
and ((check\$3 detect\$3  
sens\$3 measur\$3  
comput\$3 calculat\$3  
\$2valuat\$3 examin\$3  
test\$3 determin\$3  
recogniz\$3 inspect\$3  
analy\$4 anali\$4 monitor  
\$3 diagnos\$3 identif\$4  
record\$3 meter\$3 gaug  
\$3 judg\$3 find\$3 indicat  
\$3 verif\$4 captur\$3)  
near2 capacitance) and  
((presen\$3 absen\$3 exist  
\$5 proximity  
appearance) near2  
(object person body  
target finger subject  
member element  
structure cable wire  
component conductor  
human occupancy  
human driver operator  
occupancy occup\$5))  
with ((pre\$1select\$3 pre  
\$1determin\$3 pre  
\$1defin\$3 specif\$5 pre  
\$1set\$4 maximum  
minimum limit  
threshold reference desir  
\$5 expected wanted  
standard known model  
second spare bench  
\$1mark stored) near2  
time near2 (period  
interval cycle duration  
shift relay range band  
block)))clm.



L29	15	<p>(((check\$3 detect\$3 sens\$3 examin\$3 determin\$3 recogniz\$3 inspect\$3 analy\$4 anali\$4 monitor\$3 diagnos\$3 identif\$4 record\$3 judg\$3 find\$3 indicat\$3 verif\$4 captur\$3) near2 (presen\$3 absen\$3 exist\$5 proximity appearance) near2 (user object person body target finger subject member element structure cable wire component conductor human occupancy human driver operator occupancy occup\$5)) with capacitance) and ((check\$3 detect\$3 sens\$3 measur\$3 comput\$3 calculat\$3 \$2valuat\$3 examin\$3 test\$3 determin\$3 recogniz\$3 inspect\$3 analy\$4 anali\$4 monitor\$3 diagnos\$3 identif\$4 record\$3 meter\$3 gaug\$3 judg\$3 find\$3 indicat\$3 verif\$4 captur\$3) near2 capacitance) and ((presen\$3 absen\$3 exist\$5 proximity appearance) near2 (object person body target finger subject member element structure cable wire component conductor human occupancy human driver operator occupancy occup\$5)) and((pre\$1select\$3 pre\$1determin\$3 pre\$1defin\$3 specif\$5 pre\$1set\$4 maximum minimum limit threshold reference desir\$5 expected wanted standard known model second spare bench</p>	US-PGPUB; USPAT; UPAD	OR	ON	2011/01/16 11:27
-----	----	--	-----------------------	----	----	------------------

		\$1 mark stored) near2 time near2 (period interval cycle duration shift relay range band block))).clm.				
L30	36	((check\$3 detect\$3 sens \$3 examin\$3 determin \$3 recogniz\$3 inspect \$3 analy\$4 anali\$4 monitor\$3 diagnos\$3 identif\$4 record\$3 judg \$3 find\$3 indicat\$3 verif\$4 captur\$3) near2 (presen\$3 absen\$3 exist \$5 proximity appearance) near2 (user object person body target finger subject member element structure cable wire component conductor human occupancy human driver operator occupancy occup\$5)) and ((check\$3 detect\$3 sens\$3 measur\$3 comput\$3 calculat\$3 \$2valuat\$3 examin\$3 test\$3 determin\$3 recogniz\$3 inspect\$3 analy\$4 anali\$4 monitor \$3 diagnos\$3 identif\$4 record\$3 meter\$3 gaug \$3 judg\$3 find\$3 indicat \$3 verif\$4 captur\$3) near2 capacitance) and ((presen\$3 absen\$3 exist \$5 proximity appearance) near2 (object person body target finger subject member element structure cable wire component conductor human occupancy human driver operator occupancy occup\$5)) and ((pre\$1select\$3 pre \$1determin\$3 pre \$1defin\$3 specif\$5 pre \$1set\$4 maximum minimum limit	US-PGPUB; USPAT; UPAD	OR	ON	2011/01/16 11:27

threshold reference desir				
\$5 expected wanted				
standard known model				
second spare bench				
\$1mark stored) near2				
time near2 (period				
interval cycle duration				
shift relay range band				
block)))clm.				

1/16/11 2:06:36 PM

C:\Documents and Settings\hnguyen26\My Documents\EAST\Workspaces\12179769.wsp

Under the Paperwork Reduction Act of 1995, no persons are required to respond to a collection of information unless it displays a valid OMB control number.

**POWER OF ATTORNEY TO PROSECUTE APPLICATIONS BEFORE THE USPTO**

I hereby revoke all previous powers of attorney given in the application identified in the attached statement under 37 CFR 3.73(b).

I hereby appoint:

Practitioners associated with the Customer Number: 12323

OR

Practitioner(s) named below (if more than ten patent practitioners are to be named, then a customer number must be used):

Name	Registration Number	Name	Registration Number

as attorney(s) or agent(s) to represent the undersigned before the United States Patent and Trademark Office (USPTO) in connection with any and all patent applications assigned only to the undersigned according to the USPTO assignment records or assignment documents attached to this form in accordance with 37 CFR 3.73(b).

Please change the correspondence address for the application identified in the attached statement under 37 CFR 3.73(b) to:

The address associated with Customer Number: 12323

OR

<input type="checkbox"/> Firm or Individual Name			
Address			
City	State	Zip	
Country			
Telephone	Email		

Assignee Name and Address:  
 Atmel Corporation  
 2325 Orchard Parkway  
 San Jose, CA 95131

A copy of this form, together with a statement under 37 CFR 3.73(b) (Form PTO/SB/96 or equivalent) is required to be filed in each application in which this form is used. The statement under 37 CFR 3.73(b) may be completed by one of the practitioners appointed in this form if the appointed practitioner is authorized to act on behalf of the assignee, and must identify the application in which this Power of Attorney is to be filed.

**SIGNATURE of Assignee of Record**  
 The individual whose signature and title is supplied below is authorized to act on behalf of the assignee

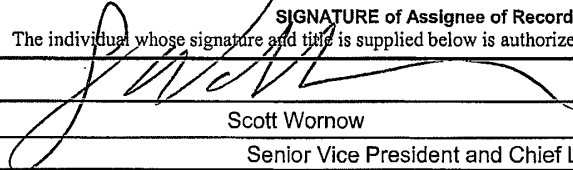
Signature		Date	1/15/12
Name	Scott Wornow	Telephone	408-436-4229
Title	Senior Vice President and Chief Legal Officer		

This collection of information is required by 37 CFR 1.31, 1.32 and 1.33. The information is required to obtain or retain a benefit by the public which is to file (and by the USPTO to process) an application. Confidentiality is governed by 35 U.S.C. 122 and 37 CFR 1.11 and 1.14. This collection is estimated to take 3 minutes to complete, including gathering, preparing, and submitting the completed application form to the USPTO. Time will vary depending upon the individual case. Any comments on the amount of time you require to complete this form and/or suggestions for reducing this burden, should be sent to the Chief Information Officer, U.S. Patent and Trademark Office, U.S. Department of Commerce, P.O. Box 1450, Alexandria, VA 22313-1450. DO NOT SEND FEES OR COMPLETED FORMS TO THIS ADDRESS. SEND TO: Commissioner for Patents, P.O. Box 1450, Alexandria, VA 22313-1450.

*If you need assistance in completing the form, call 1-800-PTO-9199 and select option 2.*

Under the Paperwork Reduction Act of 1995, no persons are required to respond to a collection of information unless it displays a valid OMB control number.

**STATEMENT UNDER 37 CFR 3.73(b)**Applicant/Patent Owner: Harald Philipp et al. 080900.0188Application No./Patent No.: 11/750,430 Filed/Issue Date: July 25, 2008Titled: Proximity SensorAtmel Corporation, a Delaware corporation  
(Name of Assignee) (Type of Assignee, e.g., corporation, partnership, university, government agency, etc.)

states that it is:

1.  the assignee of the entire right, title, and interest in;
2.  an assignee of less than the entire right, title, and interest in  
(The extent (by percentage) of its ownership interest is \_\_\_\_\_ %); or
3.  the assignee of an undivided interest in the entirety of (a complete assignment from one of the joint inventors was made)

the patent application/patent identified above, by virtue of either:

- A.  An assignment from the inventor(s) of the patent application/patent identified above. The assignment was recorded in the United States Patent and Trademark Office at Reel \_\_\_\_\_, Frame \_\_\_\_\_, or for which a copy therefore is attached.

**OR**

- B.  A chain of title from the inventor(s), of the patent application/patent identified above, to the current assignee as follows:

1. From: Harald Philipp and Kevin Snoad To: QRG Limited

The document was recorded in the United States Patent and Trademark Office at  
Reel 021758, Frame 0483, or for which a copy thereof is attached.

2. From: QRG Limited To: Atmel Corporation

The document was recorded in the United States Patent and Trademark Office at  
Reel 022608, Frame 0130, or for which a copy thereof is attached.

3. From: \_\_\_\_\_ To: \_\_\_\_\_

The document was recorded in the United States Patent and Trademark Office at  
Reel \_\_\_\_\_, Frame \_\_\_\_\_, or for which a copy thereof is attached.

Additional documents in the chain of title are listed on a supplemental sheet(s).

As required by 37 CFR 3.73(b)(1)(i), the documentary evidence of the chain of title from the original owner to the assignee was, or concurrently is being, submitted for recordation pursuant to 37 CFR 3.11.

[NOTE: A separate copy (i.e., a true copy of the original assignment document(s)) must be submitted to Assignment Division in accordance with 37 CFR Part 3, to record the assignment in the records of the USPTO. See MPEP 302.08]

The undersigned (whose title is supplied below) is authorized to act on behalf of the assignee.

/travis w. thomas/ REG. NO. 48667

Signature

Travis W. Thomas

Printed or Typed Name

February 9, 2011

Date

Attorney of Record

Title

This collection of information is required by 37 CFR 3.73(b). The information is required to obtain or retain a benefit by the public which is to file (and by the USPTO to process) an application. Confidentiality is governed by 35 U.S.C. 122 and 37 CFR 1.11 and 1.14. This collection is estimated to take 12 minutes to complete, including gathering, preparing, and submitting the completed application form to the USPTO. Time will vary depending upon the individual case. Any comments on the amount of time you require to complete this form and/or suggestions for reducing this burden, should be sent to the Chief Information Officer, U.S. Patent and Trademark Office, U.S. Department of Commerce, P.O. Box 1450, Alexandria, VA 22313-1450. DO NOT SEND FEES OR COMPLETED FORMS TO THIS ADDRESS. SEND TO: Commissioner for Patents, P.O. Box 1450, Alexandria, VA 22313-1450.

If you need assistance in completing the form, call 1-800-PTO-9199 and select option 2.

Petitioner STMICROELECTRONICS, INC.,

Ex. 1022, IPR2021-01160

Page 317 of 342

## Electronic Acknowledgement Receipt

<b>EFS ID:</b>	9408534
<b>Application Number:</b>	12179769
<b>International Application Number:</b>	
<b>Confirmation Number:</b>	8745
<b>Title of Invention:</b>	PROXIMITY SENSOR
<b>First Named Inventor/Applicant Name:</b>	Harald Philipp
<b>Customer Number:</b>	76287
<b>Filer:</b>	David Osborn Taylor/Glenda Orrantia
<b>Filer Authorized By:</b>	David Osborn Taylor
<b>Attorney Docket Number:</b>	3050.030US1
<b>Receipt Date:</b>	09-FEB-2011
<b>Filing Date:</b>	25-JUL-2008
<b>Time Stamp:</b>	14:52:11
<b>Application Type:</b>	Utility under 35 USC 111(a)

### Payment information:

Submitted with Payment	no
------------------------	----

### File Listing:

Document Number	Document Description	File Name	File Size(Bytes)/ Message Digest	Multi Part /.zip	Pages (if appl.)
1	Power of Attorney	0809000188POA.PDF	143746 9b33b1b0ca2b3e02c9cb84041bct284e5d7c35af	no	2

### Warnings:

### Information:

This Acknowledgement Receipt evidences receipt on the noted date by the USPTO of the indicated documents, characterized by the applicant, and including page counts, where applicable. It serves as evidence of receipt similar to a Post Card, as described in MPEP 503.

**New Applications Under 35 U.S.C. 111**

If a new application is being filed and the application includes the necessary components for a filing date (see 37 CFR 1.53(b)-(d) and MPEP 506), a Filing Receipt (37 CFR 1.54) will be issued in due course and the date shown on this Acknowledgement Receipt will establish the filing date of the application.

**National Stage of an International Application under 35 U.S.C. 371**

If a timely submission to enter the national stage of an international application is compliant with the conditions of 35 U.S.C. 371 and other applicable requirements a Form PCT/DO/EO/903 indicating acceptance of the application as a national stage submission under 35 U.S.C. 371 will be issued in addition to the Filing Receipt, in due course.

**New International Application Filed with the USPTO as a Receiving Office**

If a new international application is being filed and the international application includes the necessary components for an international filing date (see PCT Article 11 and MPEP 1810), a Notification of the International Application Number and of the International Filing Date (Form PCT/RO/105) will be issued in due course, subject to prescriptions concerning national security, and the date shown on this Acknowledgement Receipt will establish the international filing date of the application.



UNITED STATES PATENT AND TRADEMARK OFFICE

UNITED STATES DEPARTMENT OF COMMERCE  
United States Patent and Trademark Office  
Address: COMMISSIONER FOR PATENTS  
P.O. Box 1450  
Alexandria, Virginia 22313-1450  
www.uspto.gov

APPLICATION NUMBER	FILING OR 371(C) DATE	FIRST NAMED APPLICANT	ATTY. DOCKET NO./TITLE
12/179,769	07/25/2008	Harald Philipp	3050.030US1

**CONFIRMATION NO. 8745**

**POA ACCEPTANCE LETTER**

12323  
Baker Botts L.L.P.  
2001 Ross Avenue, 6th Floor  
Dallas, TX 75201



Date Mailed: 02/14/2011

**NOTICE OF ACCEPTANCE OF POWER OF ATTORNEY**

This is in response to the Power of Attorney filed 02/09/2011.

The Power of Attorney in this application is accepted. Correspondence in this application will be mailed to the above address as provided by 37 CFR 1.33.

/tcaldwell/

Office of Data Management, Application Assistance Unit (571) 272-4000, or (571) 272-4200, or 1-888-786-0101





UNITED STATES PATENT AND TRADEMARK OFFICE

UNITED STATES DEPARTMENT OF COMMERCE  
United States Patent and Trademark Office  
Address: COMMISSIONER FOR PATENTS  
P.O. Box 1450  
Alexandria, Virginia 22313-1450  
www.uspto.gov

APPLICATION NUMBER	FILING OR 371(C) DATE	FIRST NAMED APPLICANT	ATTY. DOCKET NO./TITLE
12/179,769	07/25/2008	Harald Philipp	3050.030US1

**CONFIRMATION NO. 8745**

**POWER OF ATTORNEY NOTICE**

76287  
SCHWEGMAN, LUNDBERG & WOESSNER / ATMEL  
P.O. BOX 2938  
MINNEAPOLIS, MN 55402



Date Mailed: 02/14/2011

**NOTICE REGARDING CHANGE OF POWER OF ATTORNEY**

This is in response to the Power of Attorney filed 02/09/2011.

- The Power of Attorney to you in this application has been revoked by the assignee who has intervened as provided by 37 CFR 3.71. Future correspondence will be mailed to the new address of record(37 CFR 1.33).

/tcaldwell/

Office of Data Management, Application Assistance Unit (571) 272-4000, or (571) 272-4200, or 1-888-786-0101



UNITED STATES PATENT AND TRADEMARK OFFICE

UNITED STATES DEPARTMENT OF COMMERCE  
 United States Patent and Trademark Office  
 Address: COMMISSIONER FOR PATENTS  
 P.O. Box 1450  
 Alexandria, Virginia 22313-1450  
 www.uspto.gov



Bib Data Sheet

CONFIRMATION NO. 8745

<b>SERIAL NUMBER</b> 12/179,769	<b>FILING OR 371(c) DATE</b> 07/25/2008	<b>CLASS</b> 324	<b>GROUP ART UNIT</b> 2858	<b>ATTORNEY DOCKET NO.</b> 3050.030US1	
<b>APPLICANTS</b> Harald Philipp, Southampton, UNITED KINGDOM; Kevin Snoad, Chicester, UNITED KINGDOM;					
** CONTINUING DATA ***** This appln claims benefit of 60/952,053 07/26/2007					
** FOREIGN APPLICATIONS *****					
IF REQUIRED, FOREIGN FILING LICENSE GRANTED ** 08/01/2008					
Foreign Priority claimed <input type="checkbox"/> yes <input type="checkbox"/> no		STATE OR COUNTRY UNITED KINGDOM	SHEETS DRAWING 10	TOTAL CLAIMS 23	INDEPENDENT CLAIMS 2
35 USC 119 (a-d) conditions met <input type="checkbox"/> yes <input type="checkbox"/> no <input type="checkbox"/> Met after Allowance					
Verified and Acknowledged		Examiner's Signature	Initials		
<b>ADDRESS</b> 12323					
<b>TITLE</b> PROXIMITY SENSOR					
<b>FILING FEE RECEIVED</b> 1310	FEES: Authority has been given in Paper No. _____ to charge/credit DEPOSIT ACCOUNT No. _____ for following:		<input type="checkbox"/> All Fees <input type="checkbox"/> 1.16 Fees ( Filing ) <input type="checkbox"/> 1.17 Fees ( Processing Ext. of time ) <input type="checkbox"/> 1.18 Fees ( Issue ) <input type="checkbox"/> Other _____ <input type="checkbox"/> Credit		

**PART B - FEE(S) TRANSMITTAL**

Complete and send this form, together with applicable fee(s), to: **Mail** **Mail Stop ISSUE FEE**  
**Commissioner for Patents**  
**P.O. Box 1450**  
**Alexandria, Virginia 22313-1450**  
**or Fax (571)-273-2885**

INSTRUCTIONS: This form should be used for transmitting the ISSUE FEE and PUBLICATION FEE (if required). Blocks 1 through 5 should be completed where appropriate. All further correspondence including the Patent, advance orders and notification of maintenance fees will be mailed to the current correspondence address as indicated unless corrected below or directed otherwise in Block 1, by (a) specifying a new correspondence address; and/or (b) indicating a separate "FEE ADDRESS" for maintenance fee notifications.

CURRENT CORRESPONDENCE ADDRESS (Note: Use Block 1 for any change of address)

76287 7590 01/25/2011

SCHWEGMAN, LUNDBERG & WOESSNER / ATMEL  
P.O. BOX 2938  
MINNEAPOLIS, MN 55402

Note: A certificate of mailing can only be used for domestic mailings of the Fee(s) Transmittal. This certificate cannot be used for any other accompanying papers. Each additional paper, such as an assignment or formal drawing, must have its own certificate of mailing or transmission.

**Certificate of Mailing or Transmission**

I hereby certify that this Fee(s) Transmittal is being deposited with the United States Postal Service with sufficient postage for first class mail in an envelope addressed to the Mail Stop ISSUE FEE address above, or being facsimile transmitted to the USPTO (571) 273-2885, on the date indicated below.

(Depositor's name)
(Signature)
(Date)

APPLICATION NO.	FILING DATE	FIRST NAMED INVENTOR	ATTORNEY DOCKET NO.	CONFIRMATION NO.
-----------------	-------------	----------------------	---------------------	------------------

12/179,769 07/25/2008 Harald Philipp 3050.030US1 8745

TITLE OF INVENTION: PROXIMITY SENSOR

APPLN. TYPE	SMALL ENTITY	ISSUE FEE DUE	PUBLICATION FEE DUE	PREV. PAID ISSUE FEE	TOTAL FEE(S) DUE	DATE DUE
-------------	--------------	---------------	---------------------	----------------------	------------------	----------

nonprovisional NO \$1510 \$300 \$0 \$1810 04/25/2011

EXAMINER	ART UNIT	CLASS-SUBCLASS
----------	----------	----------------

NGUYEN, HOAI AN D 2858 324-663000

1. Change of correspondence address or indication of "Fee Address" (37 CFR 1.363).

- Change of correspondence address (or Change of Correspondence Address Form PTO/SB/122) attached.
- "Fee Address" indication (or "Fee Address" Indication form PTO/SB/47; Rev 03-02 or more recent) attached. **Use of a Customer Number is required.**

2. For printing on the patent front page, list

- (1) the names of up to 3 registered patent attorneys or agents OR, alternatively, 1. Baker Botts L.L.P.
- (2) the name of a single firm (having as a member a registered attorney or agent) and the names of up to 2 registered patent attorneys or agents. If no name is listed, no name will be printed. 2. \_\_\_\_\_
- 3. \_\_\_\_\_

3. ASSIGNEE NAME AND RESIDENCE DATA TO BE PRINTED ON THE PATENT (print or type)

PLEASE NOTE: Unless an assignee is identified below, no assignee data will appear on the patent. If an assignee is identified below, the document has been filed for recordation as set forth in 37 CFR 3.11. Completion of this form is NOT a substitute for filing an assignment.

(A) NAME OF ASSIGNEE (B) RESIDENCE: (CITY and STATE OR COUNTRY)

Atmel Corporation San Jose, CA

Please check the appropriate assignee category or categories (will not be printed on the patent):  Individual  Corporation or other private group entity  Government

4a. The following fee(s) are submitted:

- Issue Fee
- Publication Fee (No small entity discount permitted)
- Advance Order - # of Copies \_\_\_\_\_

4b. Payment of Fee(s): (Please first reapply any previously paid issue fee shown above)

- A check is enclosed.
- Payment by credit card. Form PTO-2038 is attached.
- The Director is hereby authorized to charge the required fee(s), any deficiency, or credit any overpayment, to Deposit Account Number 02-0384 (enclose an extra copy of this form).

5. Change in Entity Status (from status indicated above)

- a. Applicant claims SMALL ENTITY status. See 37 CFR 1.27.
- b. Applicant is no longer claiming SMALL ENTITY status. See 37 CFR 1.27(g)(2).

NOTE: The Issue Fee and Publication Fee (if required) will not be accepted from anyone other than the applicant; a registered attorney or agent; or the assignee or other party in interest as shown by the records of the United States Patent and Trademark Office.

Authorized Signature /travis w. THOMAS/

Date April 25, 2011

Typed or printed name Travis W. Thomas

Registration No. 48667

This collection of information is required by 37 CFR 1.311. The information is required to obtain or retain a benefit by the public which is to file (and by the USPTO to process) an application. Confidentiality is governed by 35 U.S.C. 122 and 37 CFR 1.14. This collection is estimated to take 12 minutes to complete, including gathering, preparing, and submitting the completed application form to the USPTO. Time will vary depending upon the individual case. Any comments on the amount of time you require to complete this form and/or suggestions for reducing this burden, should be sent to the Chief Information Officer, U.S. Patent and Trademark Office, U.S. Department of Commerce, P.O. Box 1450, Alexandria, Virginia 22313-1450. DO NOT SEND FEES OR COMPLETED FORMS TO THIS ADDRESS. SEND TO: Commissioner for Patents, P.O. Box 1450, Alexandria, Virginia 22313-1450.

Under the Paperwork Reduction Act of 1995, no persons are required to respond to a collection of information unless it displays a valid OMB control number.

ATTORNEY DOCKET  
080900.0188  
P031213-QRG

PATENT APPLICATION  
12/179769

IN THE UNITED STATES PATENT AND TRADEMARK OFFICE

First Named Inventor: Harald Philipp  
Application No.: 12/179769  
Title: *Proximity Sensor*  
Filed: 25 July 2008  
Art Unit: 2858  
Examiner: Hoai An D. Nguyen  
Notice of Allowance Mailed: 25 January 2011  
Confirmation No.: 8745

**Response to Examiner's Statement of Reasons for Allowance**

Under 37 C.F.R. § 1.104(e), Applicant files this statement commenting on the Examiner's reasons for allowance. Applicant respectfully disagrees with the Examiner's reasons for allowance to the extent that they are inconsistent with applicable case law, statutes, and regulations. Applicant does not admit to any characterization or limitation of the claims or to any characterization of any prior art by the Examiner, particularly any that are inconsistent with the language of the claims considered in their entirety and including all their constituent limitations.

Respectfully submitted,  
BAKER BOTTS L.L.P.  
Attorneys for Applicant



Travis W. Thomas  
Registration No. 48,667

Date: 25 April 2011

DAL01:1164018

**Electronic Patent Application Fee Transmittal**

<b>Application Number:</b>	12179769			
<b>Filing Date:</b>	25-Jul-2008			
<b>Title of Invention:</b>	PROXIMITY SENSOR			
<b>First Named Inventor/Applicant Name:</b>	Harald Philipp			
<b>Filer:</b>	David Osborn Taylor/Glenda Orrantia			
<b>Attorney Docket Number:</b>	080900.0188			
Filed as Large Entity				
<b>Utility under 35 USC 111(a) Filing Fees</b>				
<b>Description</b>	<b>Fee Code</b>	<b>Quantity</b>	<b>Amount</b>	<b>Sub-Total in USD(\$)</b>
<b>Basic Filing:</b>				
<b>Pages:</b>				
<b>Claims:</b>				
<b>Miscellaneous-Filing:</b>				
<b>Petition:</b>				
<b>Patent-Appeals-and-Interference:</b>				
<b>Post-Allowance-and-Post-Issuance:</b>				
Utility Appl issue fee	1501	1	1510	1510
Publ. Fee- early, voluntary, or normal	1504	1	300	300

Description	Fee Code	Quantity	Amount	Sub-Total in USD(\$)
<b>Extension-of-Time:</b>				
<b>Miscellaneous:</b>				
<b>Total in USD (\$)</b>				<b>1810</b>

## Electronic Acknowledgement Receipt

<b>EFS ID:</b>	9944349
<b>Application Number:</b>	12179769
<b>International Application Number:</b>	
<b>Confirmation Number:</b>	8745
<b>Title of Invention:</b>	PROXIMITY SENSOR
<b>First Named Inventor/Applicant Name:</b>	Harald Philipp
<b>Customer Number:</b>	12323
<b>Filer:</b>	David Osborn Taylor/Glenda Orrantia
<b>Filer Authorized By:</b>	David Osborn Taylor
<b>Attorney Docket Number:</b>	080900.0188
<b>Receipt Date:</b>	25-APR-2011
<b>Filing Date:</b>	25-JUL-2008
<b>Time Stamp:</b>	10:55:43
<b>Application Type:</b>	Utility under 35 USC 111(a)

### Payment information:

Submitted with Payment	yes
Payment Type	Deposit Account
Payment was successfully received in RAM	\$ 1810
RAM confirmation Number	6388
Deposit Account	020384
Authorized User	

### File Listing:

Document Number	Document Description	File Name	File Size(Bytes)/ Message Digest	Multi Part /.zip	Pages (if appl.)
-----------------	----------------------	-----------	-------------------------------------	------------------	------------------

1	Issue Fee Payment (PTO-85B)	0809000188IF.PDF	101907 225767e55412c08491aca5d251224f73bddf5b19	no	1
<b>Warnings:</b>					
<b>Information:</b>					
2	Post Allowance Communication - Incoming	0809000188Reasons.pdf	67312 9d6cbd2c85a26237b7d80992c1709f589b9409b5	no	1
<b>Warnings:</b>					
<b>Information:</b>					
3	Fee Worksheet (PTO-875)	fee-info.pdf	31941 f03b2ce66797c7a556ce98688a6abeb28ec2fe7ab	no	2
<b>Warnings:</b>					
<b>Information:</b>					
<b>Total Files Size (in bytes):</b>				201160	
<p>This Acknowledgement Receipt evidences receipt on the noted date by the USPTO of the indicated documents, characterized by the applicant, and including page counts, where applicable. It serves as evidence of receipt similar to a Post Card, as described in MPEP 503.</p> <p><b><u>New Applications Under 35 U.S.C. 111</u></b>  If a new application is being filed and the application includes the necessary components for a filing date (see 37 CFR 1.53(b)-(d) and MPEP 506), a Filing Receipt (37 CFR 1.54) will be issued in due course and the date shown on this Acknowledgement Receipt will establish the filing date of the application.</p> <p><b><u>National Stage of an International Application under 35 U.S.C. 371</u></b>  If a timely submission to enter the national stage of an international application is compliant with the conditions of 35 U.S.C. 371 and other applicable requirements a Form PCT/DO/EO/903 indicating acceptance of the application as a national stage submission under 35 U.S.C. 371 will be issued in addition to the Filing Receipt, in due course.</p> <p><b><u>New International Application Filed with the USPTO as a Receiving Office</u></b>  If a new international application is being filed and the international application includes the necessary components for an international filing date (see PCT Article 11 and MPEP 1810), a Notification of the International Application Number and of the International Filing Date (Form PCT/RO/105) will be issued in due course, subject to prescriptions concerning national security, and the date shown on this Acknowledgement Receipt will establish the international filing date of the application.</p>					





UNITED STATES PATENT AND TRADEMARK OFFICE

UNITED STATES DEPARTMENT OF COMMERCE  
United States Patent and Trademark Office  
Address: COMMISSIONER FOR PATENTS  
P. O. Box 1450  
Alexandria, Virginia 22313-1450  
www.uspto.gov

APPLICATION NO.	ISSUE DATE	PATENT NO.	ATTORNEY DOCKET NO.	CONFIRMATION NO.
12/179,769	05/31/2011	7952366	080900.0188	8745

12323 7590 05/11/2011  
Baker Botts L.L.P.  
2001 Ross Avenue, 6th Floor  
Dallas, TX 75201

**ISSUE NOTIFICATION**

The projected patent number and issue date are specified above.

**Determination of Patent Term Adjustment under 35 U.S.C. 154 (b)**  
(application filed on or after May 29, 2000)

The Patent Term Adjustment is 374 day(s). Any patent to issue from the above-identified application will include an indication of the adjustment on the front page.

If a Continued Prosecution Application (CPA) was filed in the above-identified application, the filing date that determines Patent Term Adjustment is the filing date of the most recent CPA.

Applicant will be able to obtain more detailed information by accessing the Patent Application Information Retrieval (PAIR) WEB site (<http://pair.uspto.gov>).

Any questions regarding the Patent Term Extension or Adjustment determination should be directed to the Office of Patent Legal Administration at (571)-272-7702. Questions relating to issue and publication fee payments should be directed to the Application Assistance Unit (AAU) of the Office of Data Management (ODM) at (571)-272-4200.

APPLICANT(s) (Please see PAIR WEB site <http://pair.uspto.gov> for additional applicants):

Harald Philipp, Southampton, UNITED KINGDOM;  
Kevin Snoad, Chicester, UNITED KINGDOM;

IN THE UNITED STATES PATENT AND TRADEMARK OFFICE

Patentee: Atmel Corporation  
U.S. Patent No.: US 7,952,366 B2  
Issue Date: May 31, 2011  
Serial No.: 12/179,769  
Filing Date: July 25, 2008  
Confirmation No.: 8745  
Title: Proximity Sensor

Commissioner for Patents  
P.O. Box 1450  
Alexandria, VA 22313-1450

Dear Sir:

**REQUEST FOR CERTIFICATE OF CORRECTION**  
**UNDER 37 CFR § 1.322**

It is respectfully requested that a Certificate of Correction be issued in accordance with the enclosed Form PTO-1050. The error involved is believed to be a Patent Office error, and it is believed that no fee is due in association with this request for a Certificate of Correction. However, the Commissioner is hereby authorized to charge any fees or credit any overpayments to Deposit Account No. 02-0384 of Baker Botts L.L.P.

It is respectfully submitted that a significant error is present in the printed patent, that correction thereof in accordance with the enclosed Form PTO-1050 is required in order that no misunderstanding will occur.

Respectfully submitted,  
BAKER BOTTS L.L.P.  
Attorneys for Applicant/Atmel Corporation

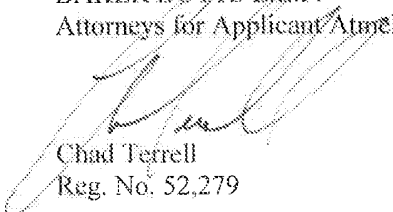
  
Chad Terrell  
Reg. No. 52,279

Date: 10/3/13  
Customer No. 12323  
Phone: (214) 953-6813

DAL01:1194908.1

UNITED STATES PATENT AND TRADEMARK OFFICE  
CERTIFICATE OF CORRECTION

Patent No.: 7,952,366  
Dated: May 31, 2011  
Inventor(s): Harald Philip, Kevin Snoad

It is certified that errors appear in the above-identified patent and that said Letters Patent is hereby corrected as shown below:

Column 13, Line 30 delete "nF/130 kg" and insert -- nF/130 kΩ --.

**Mailing Address of Sender:**

Baker Botts L.L.P.  
2001 Ross Avenue  
Dallas, TX 75201-2980

**Patent No.** 7,952,366

Form PTO-1050

## Electronic Acknowledgement Receipt

<b>EFS ID:</b>	17040968
<b>Application Number:</b>	12179769
<b>International Application Number:</b>	
<b>Confirmation Number:</b>	8745
<b>Title of Invention:</b>	PROXIMITY SENSOR
<b>First Named Inventor/Applicant Name:</b>	Harald Philipp
<b>Customer Number:</b>	12323
<b>Filer:</b>	Luke K Pedersen/Hannah Corning
<b>Filer Authorized By:</b>	Luke K Pedersen
<b>Attorney Docket Number:</b>	080900.0188
<b>Receipt Date:</b>	04-OCT-2013
<b>Filing Date:</b>	25-JUL-2008
<b>Time Stamp:</b>	12:44:24
<b>Application Type:</b>	Utility under 35 USC 111(a)

### Payment information:

Submitted with Payment	no
------------------------	----

### File Listing:

Document Number	Document Description	File Name	File Size(Bytes)/ Message Digest	Multi Part /.zip	Pages (if appl.)
1	Request for Certificate of Correction	0188.pdf	79803 <small>b35079898f8a57e3ce9464b7d027a675a5c e8019</small>	no	2

### Warnings:

### Information:

This Acknowledgement Receipt evidences receipt on the noted date by the USPTO of the indicated documents, characterized by the applicant, and including page counts, where applicable. It serves as evidence of receipt similar to a Post Card, as described in MPEP 503.

**New Applications Under 35 U.S.C. 111**

If a new application is being filed and the application includes the necessary components for a filing date (see 37 CFR 1.53(b)-(d) and MPEP 506), a Filing Receipt (37 CFR 1.54) will be issued in due course and the date shown on this Acknowledgement Receipt will establish the filing date of the application.

**National Stage of an International Application under 35 U.S.C. 371**

If a timely submission to enter the national stage of an international application is compliant with the conditions of 35 U.S.C. 371 and other applicable requirements a Form PCT/DO/EO/903 indicating acceptance of the application as a national stage submission under 35 U.S.C. 371 will be issued in addition to the Filing Receipt, in due course.

**New International Application Filed with the USPTO as a Receiving Office**

If a new international application is being filed and the international application includes the necessary components for an international filing date (see PCT Article 11 and MPEP 1810), a Notification of the International Application Number and of the International Filing Date (Form PCT/RO/105) will be issued in due course, subject to prescriptions concerning national security, and the date shown on this Acknowledgement Receipt will establish the international filing date of the application.

UNITED STATES PATENT AND TRADEMARK OFFICE  
**CERTIFICATE OF CORRECTION**

PATENT NO. : 7,952,366 B2  
APPLICATION NO. : 12/179769  
DATED : May 31, 2011  
INVENTOR(S) : Philip et al.

Page 1 of 1

It is certified that error appears in the above-identified patent and that said Letters Patent is hereby corrected as shown below:

In the Specification

Column 13, Line 30 delete "nF/130 kg" and insert -- nF/130 k $\Omega$  --.

Signed and Sealed this  
Twelfth Day of November, 2013



Teresa Stanek Rea  
*Deputy Director of the United States Patent and Trademark Office*

Under the Paperwork Reduction Act of 1995, no persons are required to respond to a collection of information unless it displays a valid OMB control number.

**POWER OF ATTORNEY TO PROSECUTE APPLICATIONS BEFORE THE USPTO**

I hereby revoke all previous powers of attorney given in the application identified in the attached statement under 37 CFR 3.73(b).

I hereby appoint:



Practitioners associated with the Customer Number:

151145

OR



Practitioner(s) named below (if more than ten patent practitioners are to be named, then a customer number must be used):

Name	Registration Number	Name	Registration Number

as attorney(s) or agent(s) to represent the undersigned before the United States Patent and Trademark Office (USPTO) in connection with any and all patent applications assigned only to the undersigned according to the USPTO assignment records or assignment documents attached to this form in accordance with 37 CFR 3.73(b).

Please change the correspondence address for the application identified in the attached statement under 37 CFR 3.73(b) to:



The address associated with Customer Number:

151145

OR

<input type="checkbox"/> Firm or Individual Name			
Address			
City	State	Zip	
Country			
Telephone	Email		

Assignee Name and Address:

Solas OLED Limited  
4-5 Burton Hall Road  
Sandyford, Dublin 18 Ireland**A copy of this form, together with a statement under 37 CFR 3.73(b) (Form PTO/SB/96 or equivalent) is required to be filed in each application in which this form is used. The statement under 37 CFR 3.73(b) may be completed by one of the practitioners appointed in this form if the appointed practitioner is authorized to act on behalf of the assignee, and must identify the application in which this Power of Attorney is to be filed.****SIGNATURE of Assignee of Record**

The individual whose signature and title is supplied below is authorized to act on behalf of the assignee

Signature		Date	Jan 25, 2019
Name	Ciaran O'Gara		Telephone
Title	Managing Director, Solas OLED Limited		

This collection of information is required by 37 CFR 1.31, 1.32 and 1.33. The information is required to obtain or retain a benefit by the public which is to file (and by the USPTO to process) an application. Confidentiality is governed by 35 U.S.C. 122 and 37 CFR 1.11 and 1.14. This collection is estimated to take 3 minutes to complete, including gathering, preparing, and submitting the completed application form to the USPTO. Time will vary depending upon the individual case. Any comments on the amount of time you require to complete this form and/or suggestions for reducing this burden, should be sent to the Chief Information Officer, U.S. Patent and Trademark Office, U.S. Department of Commerce, P.O. Box 1450, Alexandria, VA 22313-1450. DO NOT SEND FEES OR COMPLETED FORMS TO THIS ADDRESS. **SEND TO: Commissioner for Patents, P.O. Box 1450, Alexandria, VA 22313-1450.**

If you need assistance in completing the form, call 1-800-PTO-9199 and select option 2.

Petitioner STMICROELECTRONICS, INC.,

Ex. 1022, IPR2021-01160

Page 335 of 342

## Privacy Act Statement

The **Privacy Act of 1974 (P.L. 93-579)** requires that you be given certain information in connection with your submission of the attached form related to a patent application or patent. Accordingly, pursuant to the requirements of the Act, please be advised that: (1) the general authority for the collection of this information is 35 U.S.C. 2(b)(2); (2) furnishing of the information solicited is voluntary; and (3) the principal purpose for which the information is used by the U.S. Patent and Trademark Office is to process and/or examine your submission related to a patent application or patent. If you do not furnish the requested information, the U.S. Patent and Trademark Office may not be able to process and/or examine your submission, which may result in termination of proceedings or abandonment of the application or expiration of the patent.

The information provided by you in this form will be subject to the following routine uses:

1. The information on this form will be treated confidentially to the extent allowed under the Freedom of Information Act (5 U.S.C. 552) and the Privacy Act (5 U.S.C. 552a). Records from this system of records may be disclosed to the Department of Justice to determine whether disclosure of these records is required by the Freedom of Information Act.
2. A record from this system of records may be disclosed, as a routine use, in the course of presenting evidence to a court, magistrate, or administrative tribunal, including disclosures to opposing counsel in the course of settlement negotiations.
3. A record in this system of records may be disclosed, as a routine use, to a Member of Congress submitting a request involving an individual, to whom the record pertains, when the individual has requested assistance from the Member with respect to the subject matter of the record.
4. A record in this system of records may be disclosed, as a routine use, to a contractor of the Agency having need for the information in order to perform a contract. Recipients of information shall be required to comply with the requirements of the Privacy Act of 1974, as amended, pursuant to 5 U.S.C. 552a(m).
5. A record related to an International Application filed under the Patent Cooperation Treaty in this system of records may be disclosed, as a routine use, to the International Bureau of the World Intellectual Property Organization, pursuant to the Patent Cooperation Treaty.
6. A record in this system of records may be disclosed, as a routine use, to another federal agency for purposes of National Security review (35 U.S.C. 181) and for review pursuant to the Atomic Energy Act (42 U.S.C. 218(c)).
7. A record from this system of records may be disclosed, as a routine use, to the Administrator, General Services, or his/her designee, during an inspection of records conducted by GSA as part of that agency's responsibility to recommend improvements in records management practices and programs, under authority of 44 U.S.C. 2904 and 2906. Such disclosure shall be made in accordance with the GSA regulations governing inspection of records for this purpose, and any other relevant (*i.e.*, GSA or Commerce) directive. Such disclosure shall not be used to make determinations about individuals.
8. A record from this system of records may be disclosed, as a routine use, to the public after either publication of the application pursuant to 35 U.S.C. 122(b) or issuance of a patent pursuant to 35 U.S.C. 151. Further, a record may be disclosed, subject to the limitations of 37 CFR 1.14, as a routine use, to the public if the record was filed in an application which became abandoned or in which the proceedings were terminated and which application is referenced by either a published application, an application open to public inspection or an issued patent.
9. A record from this system of records may be disclosed, as a routine use, to a Federal, State, or local law enforcement agency, if the USPTO becomes aware of a violation or potential violation of law or regulation.



**STATEMENT UNDER 37 CFR 3.73(b)**

Applicant/Patent Owner: HARALD PHILIPP, KEVIN SNOAD

Application No./Patent No.: 7,952,366 Filed/Issue Date: 01-29-2009

Titled: PROXIMITY SENSOR

Solas OLED Limited, a Corporation  
(Name of Assignee) (Type of Assignee, e.g., corporation, partnership, university, government agency, etc.)

states that it is:

1.  the assignee of the entire right, title, and interest in;
2.  an assignee of less than the entire right, title, and interest in  
 (The extent (by percentage) of its ownership interest is \_\_\_\_\_ %); or
3.  the assignee of an undivided interest in the entirety of (a complete assignment from one of the joint inventors was made)

the patent application/patent identified above, by virtue of either:

A.  An assignment from the inventor(s) of the patent application/patent identified above. The assignment was recorded in the United States Patent and Trademark Office at Reel \_\_\_\_\_, Frame \_\_\_\_\_, or for which a copy therefore is attached.

**OR**

B.  A chain of title from the inventor(s), of the patent application/patent identified above, to the current assignee as follows:

1. From: PHILIPP, HARALD, SNOAD, KEVIN To: QRG LIMITED

The document was recorded in the United States Patent and Trademark Office at  
 Reel 021758, Frame 0843, or for which a copy thereof is attached.

2. From: QRG LIMITED To: ATMEL CORPORATION

The document was recorded in the United States Patent and Trademark Office at  
 Reel 022608, Frame 0130, or for which a copy thereof is attached.

3. From: MICROCHIP TECHNOLOGY INCORPORATE To: SOLAS OLED LIMITED

The document was recorded in the United States Patent and Trademark Office at  
 Reel 048201, Frame 0225, or for which a copy thereof is attached.

Additional documents in the chain of title are listed on a supplemental sheet(s).

As required by 37 CFR 3.73(b)(1)(i), the documentary evidence of the chain of title from the original owner to the assignee was, or concurrently is being, submitted for recordation pursuant to 37 CFR 3.11.

[NOTE: A separate copy (i.e., a true copy of the original assignment document(s)) must be submitted to Assignment Division in accordance with 37 CFR Part 3, to record the assignment in the records of the USPTO. See MPEP 302.08]

The undersigned (whose title is supplied below) is authorized to act on behalf of the assignee.

/Michael Messinger/  
 Signature

February 28, 2019  
 Date

Michael Messinger, 37,575  
 Printed or Typed Name

Attorney for Assignee  
 Title

This collection of information is required by 37 CFR 3.73(b). The information is required to obtain or retain a benefit by the public which is to file (and by the USPTO to process) an application. Confidentiality is governed by 35 U.S.C. 122 and 37 CFR 1.11 and 1.14. This collection is estimated to take 12 minutes to complete, including gathering, preparing, and submitting the completed application form to the USPTO. Time will vary depending upon the individual case. Any comments on the amount of time you require to complete this form and/or suggestions for reducing this burden, should be sent to the Chief Information Officer, U.S. Patent and Trademark Office, U.S. Department of Commerce, P.O. Box 1450, Alexandria, VA 22313-1450. DO NOT SEND FEES OR COMPLETED FORMS TO THIS ADDRESS. SEND TO: Commissioner for Patents, P.O. Box 1450, Alexandria, VA 22313-1450.

If you need assistance in completing the form, call 1-800-PTO-9199 and select option 2.

## Privacy Act Statement

The **Privacy Act of 1974 (P.L. 93-579)** requires that you be given certain information in connection with your submission of the attached form related to a patent application or patent. Accordingly, pursuant to the requirements of the Act, please be advised that: (1) the general authority for the collection of this information is 35 U.S.C. 2(b)(2); (2) furnishing of the information solicited is voluntary; and (3) the principal purpose for which the information is used by the U.S. Patent and Trademark Office is to process and/or examine your submission related to a patent application or patent. If you do not furnish the requested information, the U.S. Patent and Trademark Office may not be able to process and/or examine your submission, which may result in termination of proceedings or abandonment of the application or expiration of the patent.

The information provided by you in this form will be subject to the following routine uses:

1. The information on this form will be treated confidentially to the extent allowed under the Freedom of Information Act (5 U.S.C. 552) and the Privacy Act (5 U.S.C. 552a). Records from this system of records may be disclosed to the Department of Justice to determine whether disclosure of these records is required by the Freedom of Information Act.
2. A record from this system of records may be disclosed, as a routine use, in the course of presenting evidence to a court, magistrate, or administrative tribunal, including disclosures to opposing counsel in the course of settlement negotiations.
3. A record in this system of records may be disclosed, as a routine use, to a Member of Congress submitting a request involving an individual, to whom the record pertains, when the individual has requested assistance from the Member with respect to the subject matter of the record.
4. A record in this system of records may be disclosed, as a routine use, to a contractor of the Agency having need for the information in order to perform a contract. Recipients of information shall be required to comply with the requirements of the Privacy Act of 1974, as amended, pursuant to 5 U.S.C. 552a(m).
5. A record related to an International Application filed under the Patent Cooperation Treaty in this system of records may be disclosed, as a routine use, to the International Bureau of the World Intellectual Property Organization, pursuant to the Patent Cooperation Treaty.
6. A record in this system of records may be disclosed, as a routine use, to another federal agency for purposes of National Security review (35 U.S.C. 181) and for review pursuant to the Atomic Energy Act (42 U.S.C. 218(c)).
7. A record from this system of records may be disclosed, as a routine use, to the Administrator, General Services, or his/her designee, during an inspection of records conducted by GSA as part of that agency's responsibility to recommend improvements in records management practices and programs, under authority of 44 U.S.C. 2904 and 2906. Such disclosure shall be made in accordance with the GSA regulations governing inspection of records for this purpose, and any other relevant (*i.e.*, GSA or Commerce) directive. Such disclosure shall not be used to make determinations about individuals.
8. A record from this system of records may be disclosed, as a routine use, to the public after either publication of the application pursuant to 35 U.S.C. 122(b) or issuance of a patent pursuant to 35 U.S.C. 151. Further, a record may be disclosed, subject to the limitations of 37 CFR 1.14, as a routine use, to the public if the record was filed in an application which became abandoned or in which the proceedings were terminated and which application is referenced by either a published application, an application open to public inspection or an issued patent.
9. A record from this system of records may be disclosed, as a routine use, to a Federal, State, or local law enforcement agency, if the USPTO becomes aware of a violation or potential violation of law or regulation.

## Electronic Acknowledgement Receipt

<b>EFS ID:</b>	35282382
<b>Application Number:</b>	12179769
<b>International Application Number:</b>	
<b>Confirmation Number:</b>	8745
<b>Title of Invention:</b>	PROXIMITY SENSOR
<b>First Named Inventor/Applicant Name:</b>	Harald Philipp
<b>Customer Number:</b>	12323
<b>Filer:</b>	Michael V. Messinger
<b>Filer Authorized By:</b>	
<b>Attorney Docket Number:</b>	080900.0188
<b>Receipt Date:</b>	01-MAR-2019
<b>Filing Date:</b>	25-JUL-2008
<b>Time Stamp:</b>	16:41:07
<b>Application Type:</b>	Utility under 35 USC 111(a)

### Payment information:

Submitted with Payment	no
------------------------	----

### File Listing:

Document Number	Document Description	File Name	File Size(Bytes)/ Message Digest	Multi Part /.zip	Pages (if appl.)
1	Power of Attorney	0056000000_POAPreAIASigned.pdf	202143  7fed39f986959b0f066bd7af07da1d4ea77d313d	no	2

### Warnings:

Information:					
2	Assignee showing of ownership per 37 CFR 3.73	0056007US01_POA_TransPreAl A_PTOSB96.pdf	430305	no	2
			52a2e9ca23568963afb814f688326b271dc66f4b		
Warnings:					
Information:					
			<b>Total Files Size (in bytes):</b>	632448	
<p><b>This Acknowledgement Receipt evidences receipt on the noted date by the USPTO of the indicated documents, characterized by the applicant, and including page counts, where applicable. It serves as evidence of receipt similar to a Post Card, as described in MPEP 503.</b></p> <p><b><u>New Applications Under 35 U.S.C. 111</u></b>  <b>If a new application is being filed and the application includes the necessary components for a filing date (see 37 CFR 1.53(b)-(d) and MPEP 506), a Filing Receipt (37 CFR 1.54) will be issued in due course and the date shown on this Acknowledgement Receipt will establish the filing date of the application.</b></p> <p><b><u>National Stage of an International Application under 35 U.S.C. 371</u></b>  <b>If a timely submission to enter the national stage of an international application is compliant with the conditions of 35 U.S.C. 371 and other applicable requirements a Form PCT/DO/EO/903 indicating acceptance of the application as a national stage submission under 35 U.S.C. 371 will be issued in addition to the Filing Receipt, in due course.</b></p> <p><b><u>New International Application Filed with the USPTO as a Receiving Office</u></b>  <b>If a new international application is being filed and the international application includes the necessary components for an international filing date (see PCT Article 11 and MPEP 1810), a Notification of the International Application Number and of the International Filing Date (Form PCT/RO/105) will be issued in due course, subject to prescriptions concerning national security, and the date shown on this Acknowledgement Receipt will establish the international filing date of the application.</b></p>					



UNITED STATES PATENT AND TRADEMARK OFFICE

UNITED STATES DEPARTMENT OF COMMERCE
United States Patent and Trademark Office
Address: COMMISSIONER FOR PATENTS
P.O. Box 1450
Alexandria, Virginia 22313-1450
www.uspto.gov

Table with 4 columns: APPLICATION NUMBER (12/179,769), FILING OR 371(C) DATE (07/25/2008), FIRST NAMED APPLICANT (Harald Philipp), ATTY. DOCKET NO./TITLE (080900.0188)

CONFIRMATION NO. 8745

POWER OF ATTORNEY NOTICE



12323
Baker Botts L.L.P./Atmel Corporation
2001 Ross Avenue
SUITE 700
Dallas, TX 75201

Date Mailed: 03/08/2019

NOTICE REGARDING CHANGE OF POWER OF ATTORNEY

This is in response to the Power of Attorney filed 03/01/2019.

- The Power of Attorney to you in this application has been revoked by the assignee who has intervened as provided by 37 CFR 3.71. Future correspondence will be mailed to the new address of record(37 CFR 1.33).

Questions about the contents of this notice and the requirements it sets forth should be directed to the Office of Data Management, Application Assistance Unit, at (571) 272-4000 or (571) 272-4200 or 1-888-786-0101.

/dtinh/



UNITED STATES PATENT AND TRADEMARK OFFICE

UNITED STATES DEPARTMENT OF COMMERCE  
United States Patent and Trademark Office  
Address: COMMISSIONER FOR PATENTS  
P.O. Box 1450  
Alexandria, Virginia 22313-1450  
www.uspto.gov

APPLICATION NUMBER	FILING OR 371(C) DATE	FIRST NAMED APPLICANT	ATTY. DOCKET NO./TITLE
12/179,769	07/25/2008	Harald Philipp	080900.0188

**CONFIRMATION NO. 8745**

**POA ACCEPTANCE LETTER**



151145  
Shami Messinger PLLC  
1000 Wisconsin Ave. NW  
Suite 200  
Washington, DC 20007

Date Mailed: 03/08/2019

**NOTICE OF ACCEPTANCE OF POWER OF ATTORNEY**

This is in response to the Power of Attorney filed 03/01/2019.

The Power of Attorney in this application is accepted. Correspondence in this application will be mailed to the above address as provided by 37 CFR 1.33.

Questions about the contents of this notice and the requirements it sets forth should be directed to the Office of Data Management, Application Assistance Unit, at (571) 272-4000 or (571) 272-4200 or 1-888-786-0101.

/dtdinh/