



US009317133B2

(12) **United States Patent**  
**Korah et al.**

(10) **Patent No.:** **US 9,317,133 B2**  
(45) **Date of Patent:** **Apr. 19, 2016**

(54) **METHOD AND APPARATUS FOR GENERATING AUGMENTED REALITY CONTENT**

(75) Inventors: **Thommen Korah**, Marina Del Rey, CA (US); **Ronald Azuma**, Santa Monica, CA (US)

(73) Assignee: **Nokia Technologies Oy**, Espoo (FI)

(\*) Notice: Subject to any disclaimer, the term of this patent is extended or adjusted under 35 U.S.C. 154(b) by 477 days.

(21) Appl. No.: **12/900,990**

(22) Filed: **Oct. 8, 2010**

(65) **Prior Publication Data**

US 2012/0086727 A1 Apr. 12, 2012

(51) **Int. Cl.**

**G09G 5/00** (2006.01)  
**G06F 3/03** (2006.01)  
**G06T 19/00** (2011.01)

(52) **U.S. Cl.**

CPC ..... **G06F 3/03** (2013.01); **G06T 19/006** (2013.01)

(58) **Field of Classification Search**

USPC ..... 345/633, 632, 629  
See application file for complete search history.

(56) **References Cited**

U.S. PATENT DOCUMENTS

6,711,293 B1 3/2004 Lowe  
6,912,293 B1\* 6/2005 Korobkin ..... 382/100  
8,108,144 B2\* 1/2012 Forstall et al. .... 701/426  
8,207,964 B1\* 6/2012 Meadow et al. .... 345/419  
2002/0130906 A1 9/2002 Miyaki  
2003/0169903 A1 9/2003 Yoshikawa et al.  
2004/0194129 A1 9/2004 Carlbom et al.

2005/0051623 A1 3/2005 Okuda et al.  
2005/0085999 A1 4/2005 Onishi  
2006/0002590 A1 1/2006 Borak  
2007/0053551 A1 3/2007 Kubo et al.  
2007/0162942 A1 7/2007 Hamynen et al.  
2007/0192020 A1 8/2007 Brulle-Drews et al.  
2007/0242086 A1\* 10/2007 Tsujimoto et al. .... 345/632  
2008/0181507 A1\* 7/2008 Gope et al. .... 382/190  
2008/0211809 A1 9/2008 Kim et al.  
2008/0240573 A1 10/2008 Nakamura et al.  
2008/0310757 A1 12/2008 Wolberg et al.  
2009/0109216 A1 4/2009 Uetabira

(Continued)

FOREIGN PATENT DOCUMENTS

AU 2007362729 A1 7/2009  
CA 2 709 740 A1 7/2009

(Continued)

OTHER PUBLICATIONS

Heinrich et al., ARWeather—An Augmented Reality Weather System, 2008, IEEE International Symposium on Mixed and Augmented Reality, 187-188.\*

(Continued)

Primary Examiner — M Good Johnson

(74) Attorney, Agent, or Firm — Ditthavong & Steiner, P.C.

(57)

**ABSTRACT**

An approach is provided for providing augmented reality based on tracking. Information, including location information, orientation information, or a combination thereof of a device is determined. A representation of a location indicated based, at least in part, on the information is determined. One or more items are selected to associate with one or more points within the representation. Display information is determined to be generated, the display information including the one or more items overlaid on the representation based, at least in part, on the one or more points.

**16 Claims, 9 Drawing Sheets**

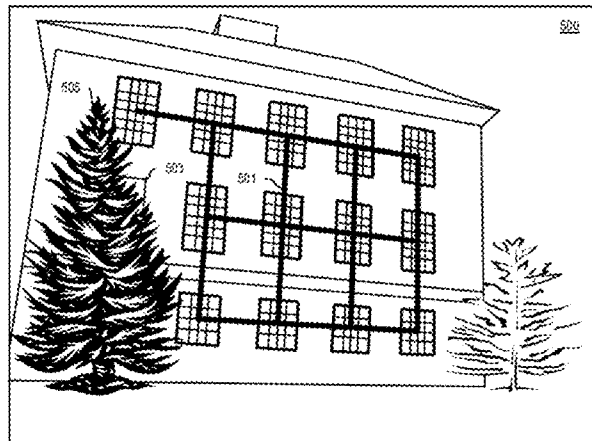

(56)

References Cited

U.S. PATENT DOCUMENTS

2009/0289955	A1*	11/2009	Douris et al. ....	345/630
2010/0161658	A1	6/2010	Hamynen et al.	
2010/0214291	A1	8/2010	Muller et al.	
2011/0063295	A1	3/2011	Kuo et al.	
2011/0103651	A1*	5/2011	Nowak et al. ....	382/106
2011/0164163	A1*	7/2011	Bilbrey et al. ....	348/333.01
2011/0279445	A1*	11/2011	Murphy et al. ....	345/419
2011/0302527	A1*	12/2011	Chen et al. ....	715/800

FOREIGN PATENT DOCUMENTS

CN	12928494	A	3/2007
CN	101275841	A	10/2008
CN	101379369	A	3/2009
CN	101903745	A	12/2010
DE	20 2007 018 604	U1	4/2009
DE	20 2007 018 605	U1	4/2009
EP	1 594 322	A2	11/2005
EP	1 612 707	A2	1/2006
EP	1 681 537	A1	7/2006
EP	1 796 048	A2	6/2007
EP	1 971 825	A1	9/2008
EP	1 975 565	A2	10/2008
EP	2 183 724	A1	5/2010
EP	2 223 041	A1	9/2010
GB	2 413 021	A	10/2005
JP	2002-340588	A	11/2002
JP	2003-263104	A	9/2003
JP	2005-083941	A	3/2005
JP	2005-121650	A	5/2005
JP	2006-030208	A	2/2006
JP	2007-074326	A	3/2007
JP	2008-0250687	A	10/2008
JP	2010-238098	A	10/2010
JP	2011-506983	A	3/2011
KR	20080076611	A	8/2008
KR	20080084859	A	9/2008
NL	20020099	C2	6/2009
NL	2002105	A1	6/2009
NL	2002105	C	4/2011
RU	2008 132 293	A	2/2010
WO	WO 96/31047	A2	10/1996
WO	WO 2005/098362	A1	10/2005
WO	WO 2007/080473	A1	7/2007
WO	WO 2007/128452	A2	11/2007
WO	WO 2008/143523	A1	11/2008
WO	WO 2009/015501	A1	2/2009
WO	WO 2009/080070	A1	7/2009

OTHER PUBLICATIONS

Madsen, Claus B., Tommy Jensen, and Mikkel S. Andersen. "Real-time image-based lighting for outdoor augmented reality under dynamically changing illumination conditions." International conference on Graphics Theory and Applications, GRAPP 2006, pp. 364-371.\*

International Search Report for related International Patent Application No. PCT/FI2011/050853 dated Feb. 13, 2012, pp. 1-7.

International Search Report for related International Patent Application No. PCT/FI2011/050864 dated Feb. 20, 2012, pp. 1-7.

International Written Opinion for related International Patent Application No. PCT/FI2011/050853 dated Feb. 13, 2012, pp. 1-9.

International Written Opinion for related International Patent Application No. PCT/FI2011/050864 dated Feb. 20, 2012, pp. 1-9.

U.S. Appl. No. 12/790,288, filed May 28, 2010, Wither, Jason et al. 3D SSD tracking with estimated 3D planes, Cobzas et al., Image and Vision Computing 27 (2009) 69-79.

Augmented Reality Scouting for Interactive 3D Reconstruction, Reitinger et al., abstract only, in Virtual Reality Conference, IEEE, 2007, 1 page.

Augmented Reality Scouting for Interactive 3D Reconstruction, Reitinger et al., accessed on: Nov. 30, 2010, [http://www.icg.tu-graz.ac.at/publications/pdf/reitingerarscouting07/at\\_download/file](http://www.icg.tu-graz.ac.at/publications/pdf/reitingerarscouting07/at_download/file), pp. 1-4.

Estimating Natural Illumination from a Single Outdoor Image, Lalonde et al., accessed on: Dec. 3, 2010, [http://graphics.cs.cmu.edu/projects/outdoorillumination/lalonde\\_iccv\\_09.pdf](http://graphics.cs.cmu.edu/projects/outdoorillumination/lalonde_iccv_09.pdf), pp. 1-8.

Fusing Online and Offline Information for Stable 3D Tracking in Real-Time, Vacchetti et al., accessed on Nov. 30, 2010, <http://cvlab.epfl.ch/publications/publications/2003/VacchettiLF03.pdf>, pp. 1-8.

Image Fusion for Context Enhancement and Video Surrealism, Raskar et al., TR2004-039, Jun. 2004, International Symposium on Non-Photorealistic Animation and Rendering, pp. 1-12.

Location-Based Games, accessed on: Dec. 3, 2010, [http://en.wikipedia.org/wiki/Location-based\\_game](http://en.wikipedia.org/wiki/Location-based_game), pp. 1-4.

Markerless Tracking using Planar Structures in the Scene, Simon et al., accessed on Nov. 30, 2010, <http://www.robots.ox.ac.uk/~vgg/publications/papers/simon00.pdf>, pp. 1-9.

Parallel Tracking and Mapping for Small AR Workspaces, Klein et al., accessed on: Dec. 3, 2010, <http://www.robots.ox.ac.uk/~gk/publications/KleinMurray2007ISMAR.pdf>, pp. 1-10.

Parallel Tracking and Mapping on a Camera Phone, Klein et al., accessed on: Dec. 3, 2010, <http://www.robots.ox.ac.uk/~gk/publications/KleinMurray2009ISMAR.pdf>, pp. 1-4.

Pose Tracking from Natural Features on Mobile Phones, Wagner et al., accessed on: Dec. 3, 2010, [http://www.icg.tugraz.at/publications/pdf/WAGNER\\_ISMAR08\\_NFT.pdf](http://www.icg.tugraz.at/publications/pdf/WAGNER_ISMAR08_NFT.pdf), pp. 1-10.

Robust Spatiotemporal Analysis of Architectural Imagery, Korah, Thommen, University of Delaware, 2007, pp. 1-190.

Seeing the World Behind the Image: Spatial Layout for 3D Scene Understanding, Hoiem, Derek, Aug. 2007, Robotics Institute, Carnegie Mellon University, pp. 1-153.

SURFTrac: Efficient Tracking and Continuous Object Recognition using Local Feature Descriptors, Ta et al., accessed on: Dec. 3, 2010, [http://people.csail.mit.edu/kapu/papers/nguyen\\_cvpr09.pdf](http://people.csail.mit.edu/kapu/papers/nguyen_cvpr09.pdf), pp. 1-8.

The Westwood Experience: Connecting Story to Locations Via Mixed Reality, Wither et al., IEEE International Symposium on Mixed and Augmented Reality 2010, Arts, Media and Humanities Proceedings, Oct. 13-16, Seoul, Korea, pp. 39-46.

Tracking with Reference Images: A Real-Time and Markerless Tracking Solution for Out-Door Augmented Reality Applications, Stricker, Didier, abstract only, in Proceedings of the 2001 conference on Virtual reality, archeology, and cultural heritage, 2001, pp. 1-2.

Tracking with Reference Images: A Real-Time and Markerless Tracking Solution for Out-Door Augmented Reality Applications, Stricker, Didier, accessed on: Nov. 30, 2010, <http://archeoguide.intranet.gr/papers/publications/ARCHEOGUIDE-VAST01-2.pdf>, pp. 1-5.

Office Action for related U.S. Appl. No. 12/939,558 dated Sep. 18, 2012, pp. 1-49.

\* cited by examiner

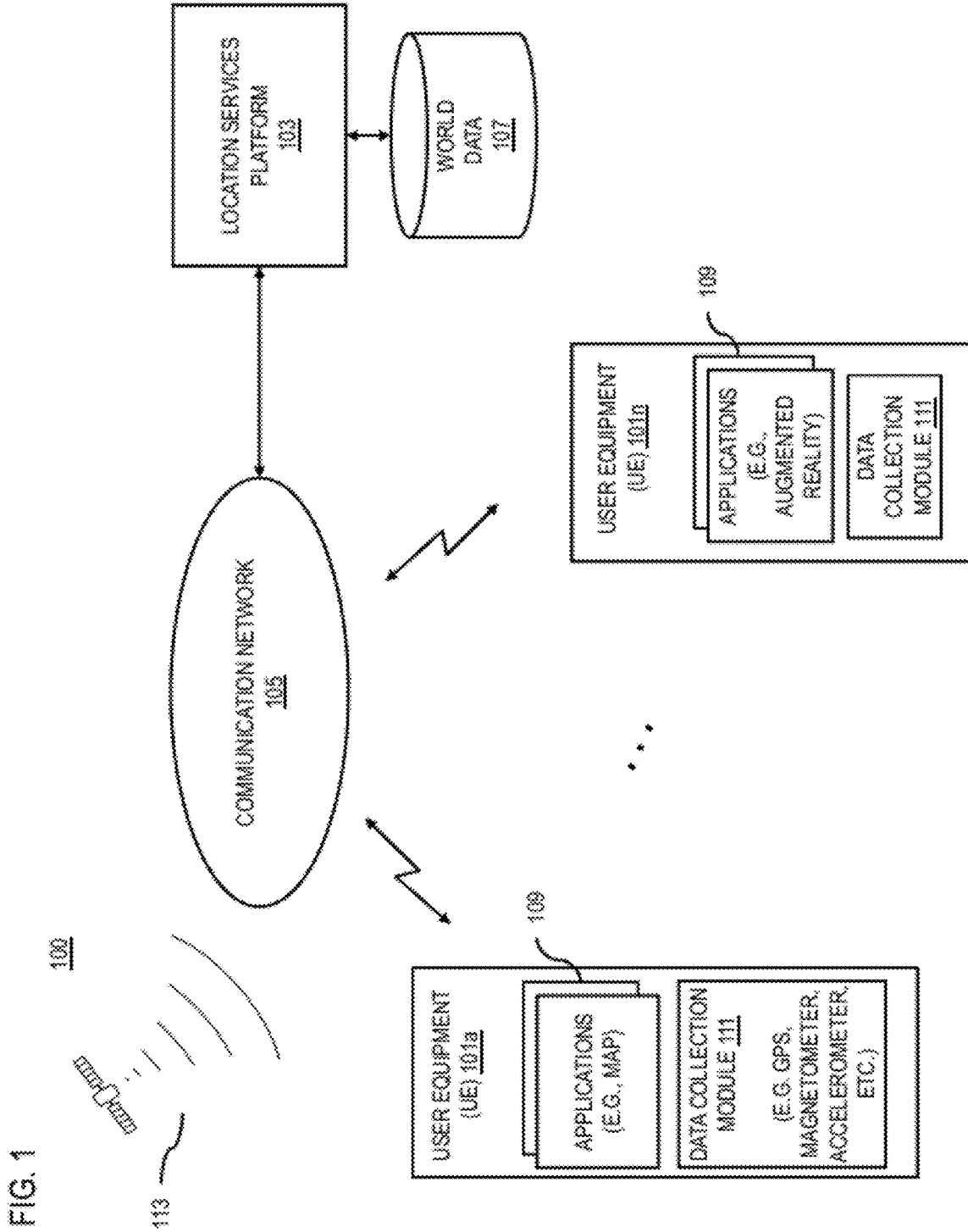

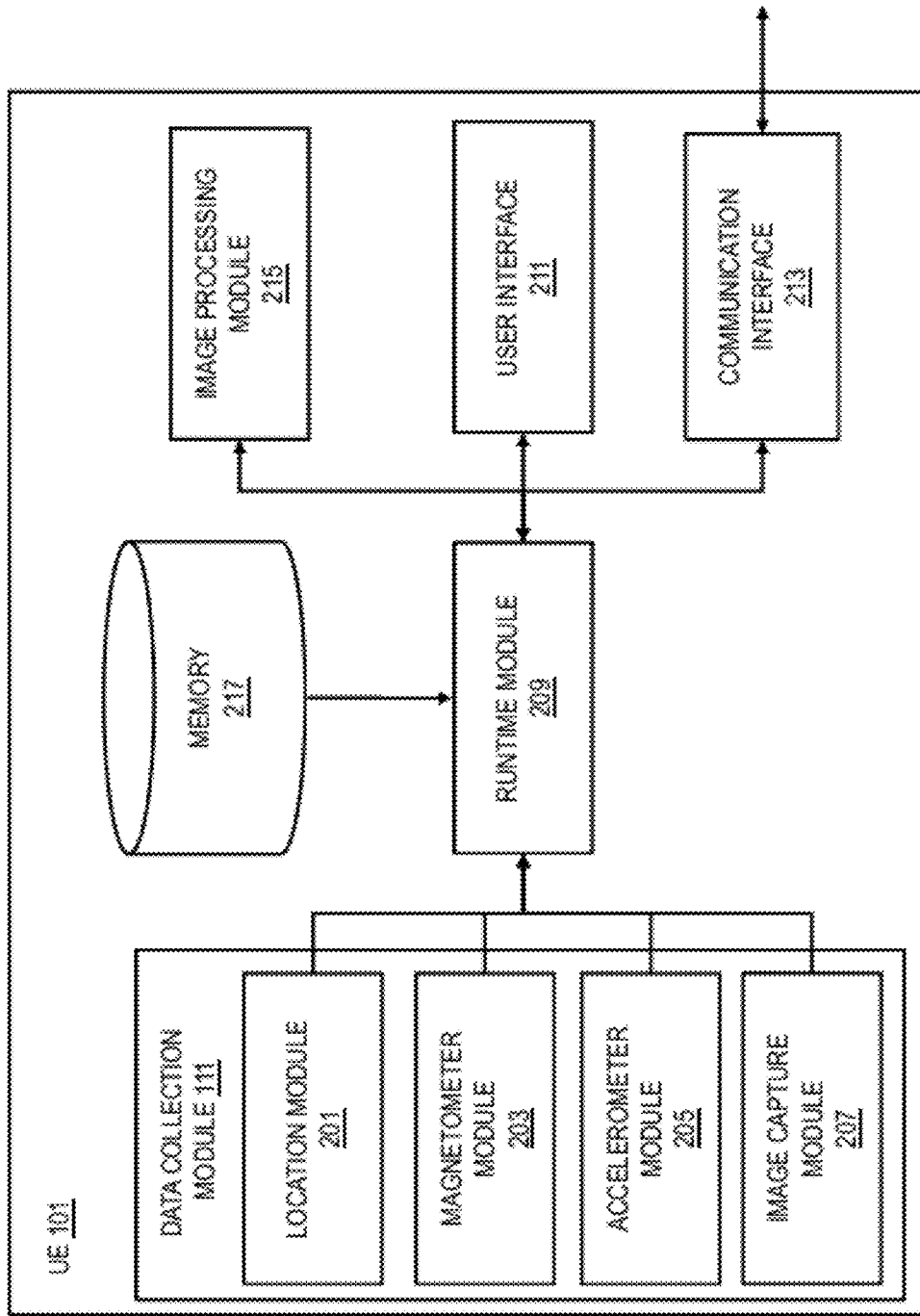
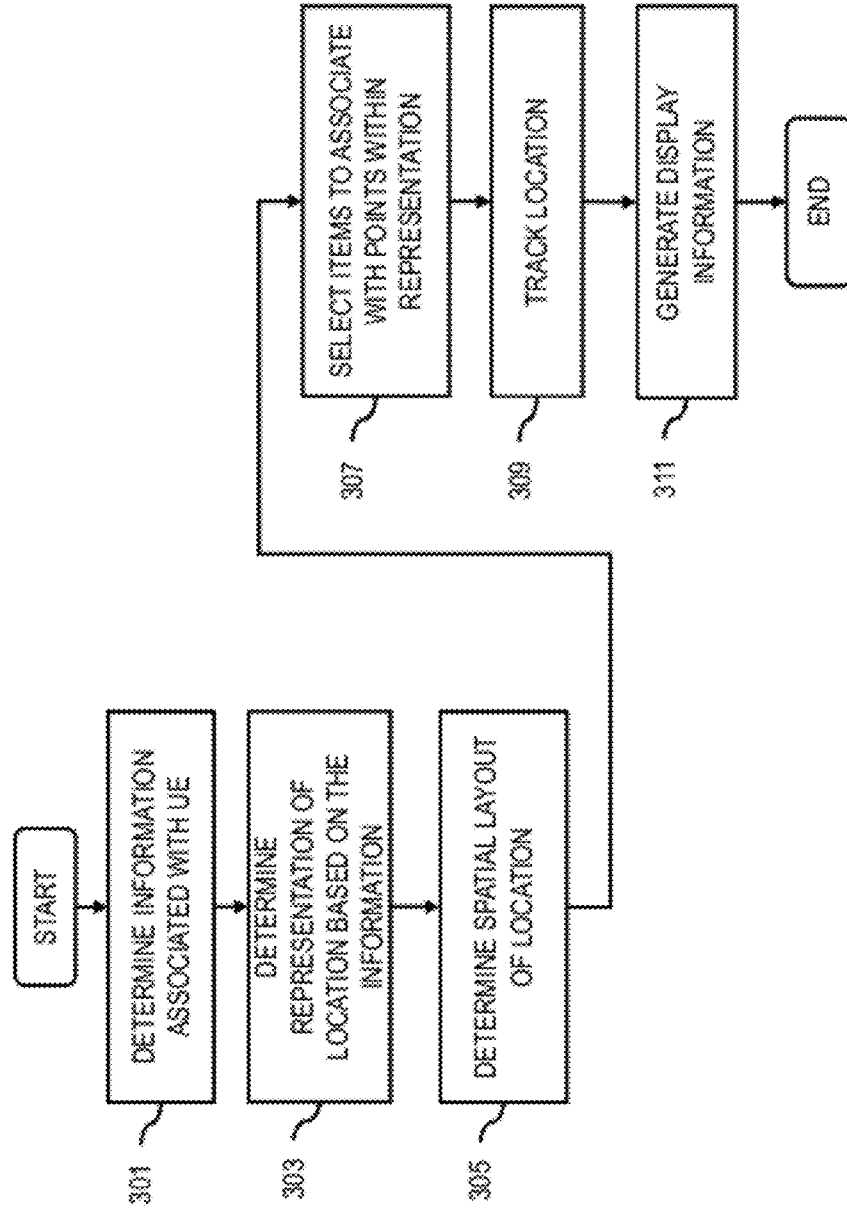

FIG. 2

FIG. 3

300



# Explore Litigation Insights

Docket Alarm provides insights to develop a more informed litigation strategy and the peace of mind of knowing you're on top of things.

## Real-Time Litigation Alerts



Keep your litigation team up-to-date with **real-time alerts** and advanced team management tools built for the enterprise, all while greatly reducing PACER spend.

Our comprehensive service means we can handle Federal, State, and Administrative courts across the country.

## Advanced Docket Research



With over 230 million records, Docket Alarm's cloud-native docket research platform finds what other services can't. Coverage includes Federal, State, plus PTAB, TTAB, ITC and NLRB decisions, all in one place.

Identify arguments that have been successful in the past with full text, pinpoint searching. Link to case law cited within any court document via Fastcase.

## Analytics At Your Fingertips



Learn what happened the last time a particular judge, opposing counsel or company faced cases similar to yours.

Advanced out-of-the-box PTAB and TTAB analytics are always at your fingertips.

## API

Docket Alarm offers a powerful API (application programming interface) to developers that want to integrate case filings into their apps.

## LAW FIRMS

Build custom dashboards for your attorneys and clients with live data direct from the court.

Automate many repetitive legal tasks like conflict checks, document management, and marketing.

## FINANCIAL INSTITUTIONS

Litigation and bankruptcy checks for companies and debtors.

## E-DISCOVERY AND LEGAL VENDORS

Sync your system to PACER to automate legal marketing.