

- [54] **ELECTRODELESS FLUORESCENT LIGHT SOURCE HAVING REDUCED FAR FIELD ELECTROMAGNETIC RADIATION LEVELS**
- [75] Inventor: **Carl F. Buhrer, Framingham, Mass.**
- [73] Assignee: **GTE Laboratories Incorporated, Waltham, Mass.**
- [21] Appl. No.: **49,773**
- [22] Filed: **Jun. 18, 1979**
- [51] Int. Cl.³ **H05B 41/16; H05B 41/24**
- [52] U.S. Cl. **315/248; 315/57; 315/70; 315/85; 336/226; 336/232**
- [58] Field of Search **315/248, 344, 39, 57, 315/85, 70; 336/226, 232**

| | | | |
|-----------|---------|---------------|---------|
| 4,017,764 | 4/1977 | Anderson | 315/248 |
| 4,053,856 | 10/1977 | Fisher et al. | 336/226 |
| 4,117,378 | 9/1978 | Glascock, Jr. | 315/248 |
| 4,119,889 | 10/1978 | Hollister | 315/248 |
| 4,171,503 | 10/1979 | Kwon | 315/344 |
| 4,187,445 | 2/1980 | Houston | 315/248 |
| 4,187,447 | 2/1980 | Stout et al. | 315/85 |

Primary Examiner—Saxfield Chatmon, Jr.
 Attorney, Agent, or Firm—William R. McClellan

[57] **ABSTRACT**

An electrodeless fluorescent light source includes an electrodeless fluorescent lamp and an induction coil wherein the magnitude of the far field electromagnetic radiation, produced directly by the induction coil, is minimized. The induction coil includes current loops which are configured so that the magnetic dipole moment of each current loop is offset by the magnetic dipole moment of other current loops in order to minimize the net magnetic dipole moment of the induction coil. One embodiment of the induction coil includes a conductor wound in the shape of a square prism. The current on adjacent side edges of the prism is in opposite directions, thus resulting in two pairs of mutually opposing magnetic dipole moments.

[56] **References Cited**
U.S. PATENT DOCUMENTS

| | | | |
|-----------|---------|-----------------|-----------|
| 1,807,927 | 6/1931 | Morrison | 315/248 X |
| 1,813,580 | 7/1931 | Morrison | 315/248 X |
| 2,471,777 | 5/1949 | Reinartz | 336/226 X |
| 2,939,049 | 5/1960 | Blackman | 315/248 X |
| 3,942,058 | 3/1976 | Haugsjaa et al. | 315/248 |
| 3,942,068 | 3/1976 | Haugsjaa et al. | 315/248 |
| 3,943,404 | 3/1976 | McNeill et al. | 315/248 |
| 3,987,334 | 10/1976 | Anderson | 315/248 |
| 3,987,335 | 10/1976 | Anderson | 315/248 |

14 Claims, 6 Drawing Figures

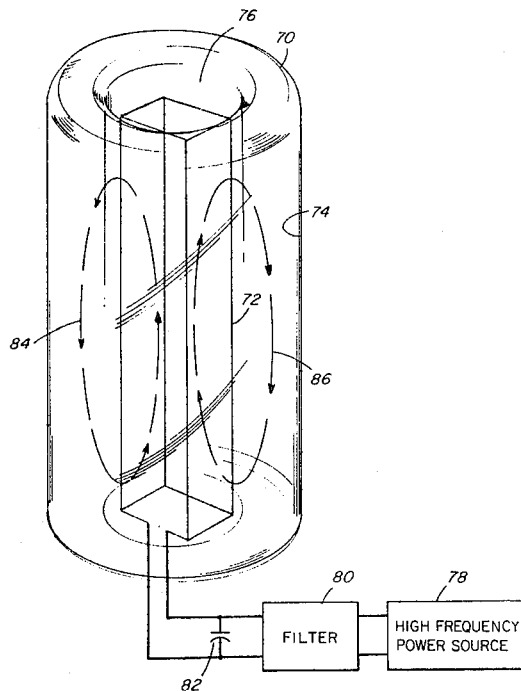

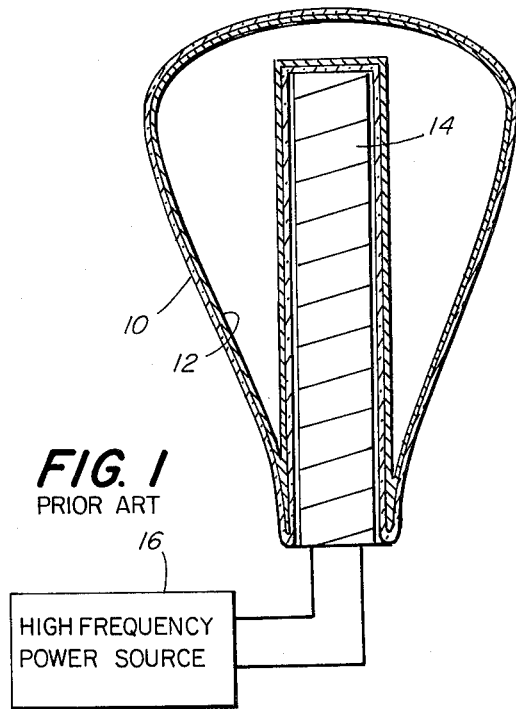

FIG. 1
PRIOR ART

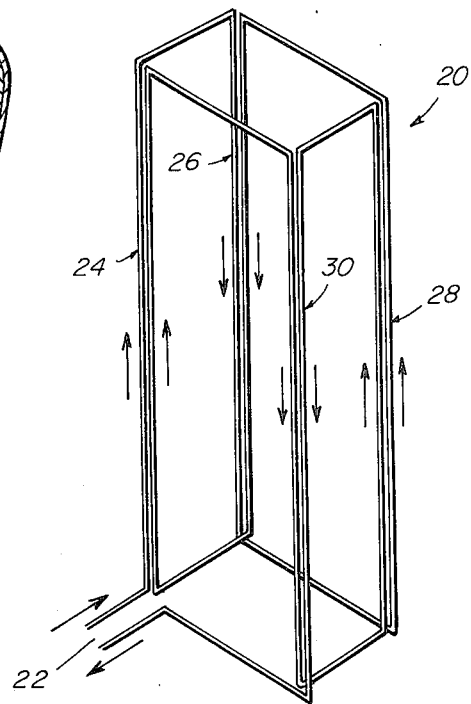

FIG. 2

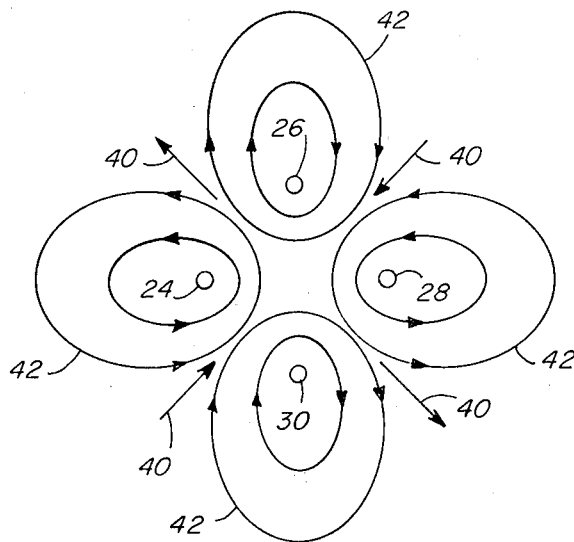

FIG. 3

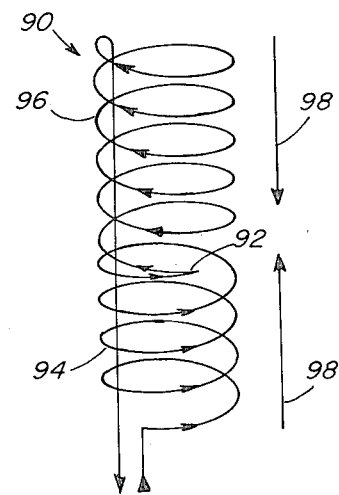
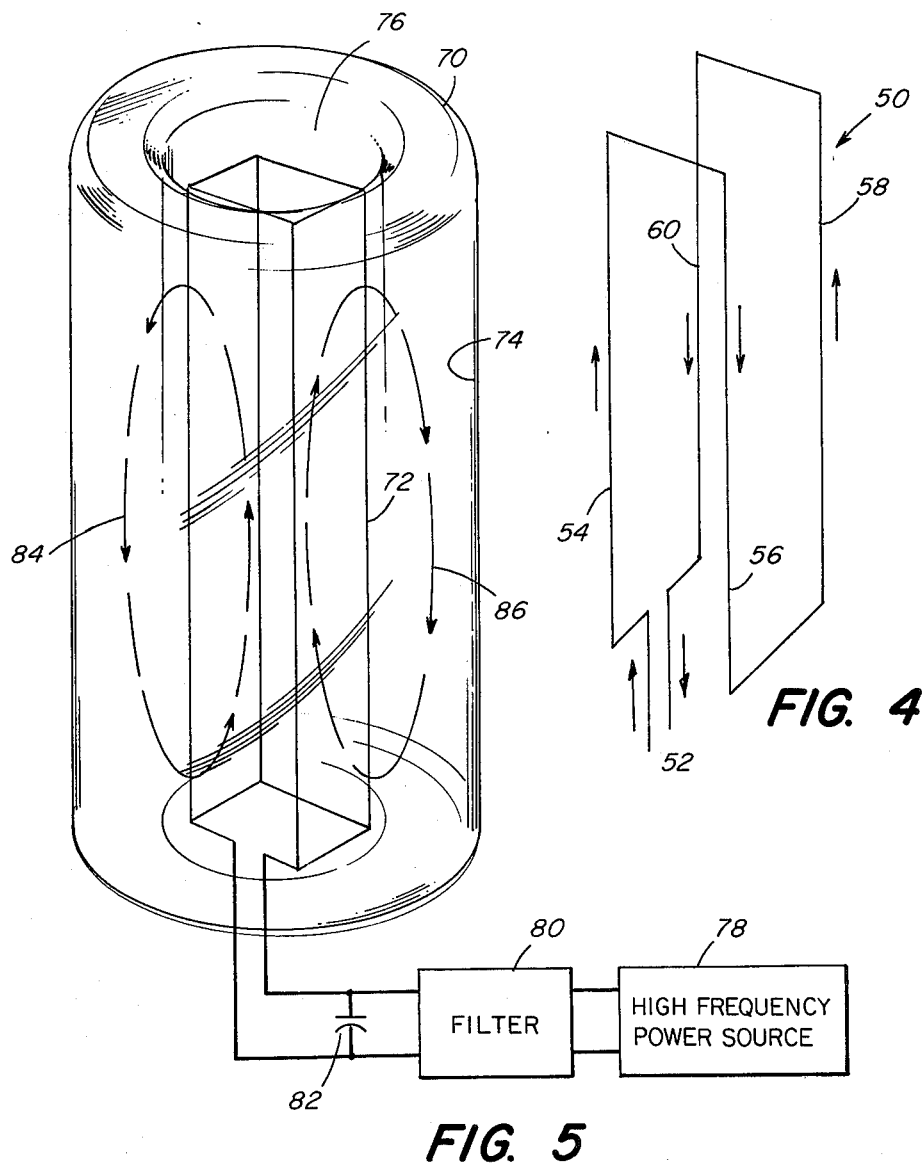

FIG. 6



ELECTRODELESS FLUORESCENT LIGHT SOURCE HAVING REDUCED FAR FIELD ELECTROMAGNETIC RADIATION LEVELS

CROSS-REFERENCE TO RELATED APPLICATION

C. F. Buhner, "Planar Electrodeless Fluorescent Light Source", assignee's docket no. 21,593, filed concurrently with the present application and assigned to the same assignee as the present application, discloses electrodeless fluorescent light sources having a planar structure and having for excitation an induction coil which produces minimal far field electromagnetic radiation levels.

BACKGROUND OF THE INVENTION

This invention relates to electrodeless fluorescent light sources excited by high frequency power. More particularly, this invention relates to electrodeless fluorescent light sources having reduced far field radiation levels.

Conventional high brightness fluorescent lamps provide long life and efficient operation but require large, heavy and expensive ballasting circuits for operation at line frequencies. The low pressure glow discharge in mercury vapor that provides the phosphor excitation in fluorescent lamps is usually powered by a current at the power line frequency between two internal emissive electrodes. Current control is required because of the negative impedance characteristic of the discharge, and this is obtained by means of the series inductive impedance of an iron core ballast. In addition, as one attempts to make small fluorescent lamps, power losses connected with the electrodes become an increasingly large fraction of the applied power. Electrodeless excitation of the glow discharge by radio frequency fields has the potential advantage of providing a light weight system by eliminating the usual ballast. Also, without the usual filaments, lamp life would be increased.

Several approaches to electrodeless fluorescent lamps have been taken in the past. In one approach, frequencies in the range of 10 to 500 KHz were used with ferrite structures designed to link the high frequency magnetic field through a closed loop of plasma discharge. In U.S. Pat. No. 3,500,118 issued Mar. 10, 1970 to Anderson and U.S. Pat. No. 3,521,120 issued July 21, 1970 to Anderson, there are disclosed electrodeless fluorescent light sources which utilize a magnetically induced radio frequency electric field to ionize a gaseous radiating medium. Ferrite cores are utilized to couple energy to the discharge. A great variety of geometries is possible. For example, the use of closed loop ferrite core circuits to minimize stray fields that can radiate was disclosed in U.S. Pat. No. 4,005,330 issued Jan. 25, 1977 to Glascock, Jr. et al.

In a second approach, the frequencies are in the 3 to 300 MHz range, and no ferrites are needed. In U.S. Pat. No. 4,010,400 issued Mar. 1, 1977 to Hollister, radio frequency power is coupled to a discharge medium contained in a phosphor coated envelope by an induction coil with a nonmagnetic core connected to a radio frequency source. Radiation by the magnetic dipole field of the excitation coil is a problem.

A third approach to electrodeless fluorescent light sources, utilizing even higher frequencies in the 100 MHz to 300 GHz range, was disclosed by Haugsjaa et al. in pending U.S. application Ser. No. 959,823 filed

Nov. 13, 1978 and assigned to the assignee of the present invention. High frequency power, typically at 915 MHz, is coupled to an ultravioletproducing low pressure discharge in a phosphor-coated electrodeless lamp which acts as a termination load within a termination fixture. Electromagnetic radiation is less of a problem at the higher frequencies of operation because shielding can be accomplished with a fine conductive mesh which blocks only a small percentage of the light output. At lower frequencies of operation, such as those disclosed in the Hollister patent, a heavier conductive mesh is required to accomplish effective shielding because of the reduced skin effect at lower frequencies. The heavier mesh is impractical because more of the light output is blocked.

Regardless of the frequency range utilized for exciting the glow discharge of a fluorescent lamp the control of electromagnetic radiation at the operating frequency and its harmonics is of high priority. In the low frequency range, a lamp system utilizing a free running class C oscillator coupled through a coil or ferrite structure to a discharge radiates harmonics randomly dispersed through the 500-1600 KHz broadcast band and gives severe radio interference. In the higher frequency range, the effect is similar, but the interference is to other classes of radio and television services. In general, therefore, the operating frequency should be fixed and chosen for electromagnetic compatibility, the power source should be well shielded with its output filtered to remove harmonics, and the coupling system and glow discharge geometry should be chosen to minimize radiation. The power source aspect of this problem was recognized in U.S. Pat. No. 4,048,541 issued Sept. 13, 1977 to Adams et al wherein a power source for an electrodeless fluorescent lamp was designed to eliminate second harmonics.

SUMMARY OF THE INVENTION

It is an object of the present invention to provide improved electrodeless fluorescent light sources wherein high frequency power is inductively coupled to the discharge and wherein the far field electromagnetic radiation produced directly by the induction coil is minimized.

According to the present invention, this and other objects and advantages are achieved in an electromagnetic discharge apparatus including an electrodeless lamp and means for excitation of the discharge in the electrodeless lamp by high frequency power. The electrodeless lamp has an envelope made of a light transmitting substance. The lamp envelope has on its inner surface a phosphor coating which emits visible light upon absorption of ultraviolet radiation and encloses a fill material which emits ultraviolet radiation during electromagnetic discharge. The excitation means includes induction coil means located in sufficiently close proximity to the electrodeless lamp to cause discharge. The induction coil means includes a plurality of current loops, each having an individual magnetic dipole moment, which emits electromagnetic radiation, and has a net magnetic dipole moment which is the vector sum of said individual magnetic dipole moments. The current loops are configured so that each individual magnetic dipole moment is offset by other individual magnetic dipole moments in order to minimize said net magnetic dipole moment. In this way, the magnitude of the far

field electromagnetic radiation, produced directly by said induction coil means, is minimized.

BRIEF DESCRIPTION OF THE DRAWINGS

In the Drawings:

FIG. 1 is a simplified sectional view of an electrodeless fluorescent light source according to the prior art.

FIG. 2 is a perspective view of an induction coil according to one embodiment of the present invention.

FIG. 3 is a top view of the induction coils shown in FIG. 2 illustrating pictorially the magnetic fields and magnetic dipole moments.

FIG. 4 is a perspective view of an induction coil according to another embodiment of the present invention.

FIG. 5 is a perspective view of a light source in accordance with the present invention.

FIG. 6 is a side view of an induction coil according to another embodiment of the present invention.

DESCRIPTION OF THE PREFERRED EMBODIMENTS

For a better understanding of the present invention, together with other and further objects, advantages and capabilities thereof, reference is made to the following disclosure and appended claims in connection with the above-described drawings.

A typical prior art electrodeless fluorescent light source is shown in FIG. 1. It includes an electrodeless lamp 10 with a phosphor coating 12, an induction coil 14, and a high frequency power source 16. The electrodeless lamp 10 has an envelope made of a light transmitting substance such as glass and encloses a fill material such as mixtures of mercury and an inert gas which emit ultraviolet light during discharge. High frequency power is coupled to the discharge by induction coil 14. The phosphor coating 12 on the inner surface of lamp 10 emits visible light upon absorption of ultraviolet light from the discharge. Such a light source is shown in U.S. Pat. No. 4,010,400. The induction coil 14 is wound in a helical configuration and radiates an appreciable amount of energy at the frequency of operation.

According to the present invention, unique configurations of the induction coil are utilized to reduce the radiated high frequency energy. Referring now to FIG. 2, there is shown an induction coil 20 having the general shape of a square prism. As used in this disclosure, the term "induction coil" is intended to include any configuration of an elongated conductor which has the purpose of coupling magnetic fields to an electrodeless lamp and is not limited to a series of spirals or rings. The induction coil 20 is formed from insulated wire and can be supported by an insulating form of dielectric material. Alternatively, the induction coil 20 can be formed from wire which has sufficient stiffness to be self-supporting. Regardless of how the induction coil 20 is supported, it can be visualized as outlining an imaginary square prism which has four rectangular side faces and two square end faces. The prism thus has four side edges formed by the intersections of the four side faces. As shown in FIG. 2, the conductor forming induction coil 20 starts at input 22 and runs up edge 24, across the top of the prism and down edge 26. The conductor then runs across the bottom of the prism, up edge 28, across the top of the prism, and down edge 26. From here, the conductor runs across the bottom of the prism, up edge 24, across the top of the prism, and down edge 30. Finally, the conductor runs across the bottom of the

prism, up edge 28, across the top of the prism, down edge 30, and across the bottom of the prism to input 22. This configuration results in two conductors along each side edge of the square prism. While other winding sequences can be used, the important requirement is that current at any instant of time must flow in opposite directions on adjacent side edges and in the same direction on diagonally opposite side edges of the prism. The direction of current flow at one instant of time on side edges 24, 26, 28 and 30 is shown in FIG. 2 by the arrows parallel to the conductors. The current in edges 24 and 28 is up whereas the current in edges 26 and 30 is down. The indicated directions of current flow, of course, reverse with time because of the alternating input current.

The induction coil 20 results in a much lower level of far field radiation than the helical coil used in the prior art. Considering individually each side face of the prism, current circulates around that face and produces a dipole radiation pattern. FIG. 3 is a top view of induction coil 20 and illustrates the magnetic dipole moment 40 produced by the current loop on each face of the prism. Also shown in FIG. 3 are the magnetic field lines 42 generated by induction coil 20. The fields produced by adjacent conductors are of opposite polarity. These are the fields which interact with the electrodeless lamp fill material as will be discussed hereinafter. The dipole moments from opposite sides of the prism also are of opposite polarity. Thus, when viewed from the far field, or distances much greater than the dimensions of induction coil 20, the dipole contribution from each face of the prism is offset by the contribution from the opposite face to give a net dipole moment of approximately zero. The resulting dipole radiation field in a practical induction coil 20 is not exactly zero because of imperfections in the coil construction and because of second order effects. One requirement for the above discussion to hold true is that the length of the conductor used to form induction coil 20 be small in comparison with the wavelength at the frequency of operation. This is necessary to insure that there is no phase retardation between radiation from dipole moments on opposite faces of the prism. It is also required that the separation between opposite faces of the prism be small in comparison with the wavelength of the excitation signal. Therefore, when an electrodeless fluorescent light source is operated at 40.68 MHz, which has a wavelength of about 7.4 meters, the maximum dimensions of induction coil 20 should be a few centimeters to avoid problems of phase retardation.

The induction coil 20 shown in FIG. 2 is one example of induction coil geometries which meet the requirements of the present invention. The essential requirement is that each dipole moment be offset by one or more dipole moments of opposite polarity to minimize the net magnetic dipole moment so that the far field electromagnetic radiation level produced directly by the induction coil is minimized. The net magnetic dipole moments of the induction coil is the vector sum of the individual magnetic dipole moments produced by each current loop of the induction coil. Thus, the prism-shaped induction coil can have a rectangular base as well as a square base. Also, the side faces of the prism can be parallelograms as well as rectangles. The dipole moments produced by opposite faces of such induction coils offset each other. In general, the base of the prism-shaped induction coil can be regular polygonal where the polygon has an even number of sides, for example,

Explore Litigation Insights

Docket Alarm provides insights to develop a more informed litigation strategy and the peace of mind of knowing you're on top of things.

Real-Time Litigation Alerts



Keep your litigation team up-to-date with **real-time alerts** and advanced team management tools built for the enterprise, all while greatly reducing PACER spend.

Our comprehensive service means we can handle Federal, State, and Administrative courts across the country.

Advanced Docket Research



With over 230 million records, Docket Alarm's cloud-native docket research platform finds what other services can't. Coverage includes Federal, State, plus PTAB, TTAB, ITC and NLRB decisions, all in one place.

Identify arguments that have been successful in the past with full text, pinpoint searching. Link to case law cited within any court document via Fastcase.

Analytics At Your Fingertips



Learn what happened the last time a particular judge, opposing counsel or company faced cases similar to yours.

Advanced out-of-the-box PTAB and TTAB analytics are always at your fingertips.

API

Docket Alarm offers a powerful API (application programming interface) to developers that want to integrate case filings into their apps.

LAW FIRMS

Build custom dashboards for your attorneys and clients with live data direct from the court.

Automate many repetitive legal tasks like conflict checks, document management, and marketing.

FINANCIAL INSTITUTIONS

Litigation and bankruptcy checks for companies and debtors.

E-DISCOVERY AND LEGAL VENDORS

Sync your system to PACER to automate legal marketing.