

UNITED STATES PATENT AND TRADEMARK OFFICE

---

BEFORE THE PATENT TRIAL AND APPEAL BOARD

---

SAMSUNG ELECTRONICS CO., LTD.  
Petitioner,

v.

DEMARAY LLC,  
Patent Owner.

---

IPR2021-01091  
Patent 7,381,657 B2

---

Before CHRISTOPHER L. CRUMBLY, KRISTINA M. KALAN, and  
KIMBERLY McGRAW, *Administrative Patent Judges*.

McGRAW, *Administrative Patent Judge*.

DECISION

Granting Institution of *Inter Partes* Review  
*35 U.S.C. § 314*

Granting Motion for Joinder  
*35 U.S.C. § 315(c); 37 C.F.R. § 42.122*

## I. INTRODUCTION

On June 11, 2021, Samsung Electronics Co., Ltd., (“Samsung” or “Petitioner”) filed a Petition requesting an *inter partes* review of claims 1–21 (“the Challenged Claims”) of U.S. Patent No. 7,381,657 B2 (Ex. 1001, “the ’657 patent”). See Paper 1 (“Pet.”); Paper 4 (Notice of Filing Date). Concurrently, Petitioner filed a Motion for Joinder seeking to join *Applied Materials, Inc. v. Demaray LLC*, IPR2021-00104 (the “Applied Materials IPR”) as a party. Paper 3 (the “Motion” or “Mot.”). *Inter partes* review was instituted in the Applied Materials IPR on May 11, 2021. See Applied Materials IPR, Paper 13 (PTAB May 11, 2021) (the “Applied Materials IPR Institution Decision”). The Petition here is substantively identical to the petition on which *inter partes* review was instituted in the Applied Materials IPR. See Mot. 3 (stating that the petition filed in this proceeding is substantively identical to the petition filed in the Applied Materials IPR and contains identical grounds, analysis, exhibits, and relies upon the same expert declarants and declarations). Demaray LLC (“Demaray” or “Patent Owner”) did not file a preliminary response to the Petition or an opposition to the Motion.

We have authority to determine whether to institute an *inter partes* review. 35 U.S.C. § 314(b) (2018); 37 C.F.R. § 42.4(a) (2020). An *inter partes* review may not be instituted “unless . . . the information presented in the petition . . . shows that there is a reasonable likelihood that the petitioner would prevail with respect to at least 1 of the claims challenged in the petition.” 35 U.S.C. § 314(a). And if we determine that a party has filed a petition that warrants institution of an *inter partes* review, we may join that party to another instituted *inter partes* review. 35 U.S.C. § 315(c).

Upon consideration of the Petition and the evidence of record, we conclude that the information presented shows a reasonable likelihood that Petitioner would prevail in showing the unpatentability of at least one of the Challenged Claims. Accordingly, we authorize an *inter partes* review to be instituted as to the Challenged Claims of the '657 patent on the grounds raised in the Petition. This is not a final decision as to patentability of claims for which *inter partes* review is instituted. Any final decision will be based on the record, as fully developed during trial. We also grant the unopposed Motion and join Petitioner to the Applied Materials IPR (IPR2021-00104).

## II. BACKGROUND

### A. The '657 Patent

The '657 patent, titled "Biased Pulse DC Reactive Sputtering of Oxide Films," issued June 3, 2008, from Application No. 10/954,182, filed October 1, 2004. Ex. 1001, codes (10), (12), (21), (22), (45), (54). The '657 patent "relates to deposition of oxide and oxynitride films and, in particular, to deposition of oxide and oxynitride films by pulsed DC reactive sputtering." *Id.* at 1:11–13. The '657 patent discloses that RF sputtering has been typically used to deposit oxide dielectric films but arcing can occur between sputtering target tiles used to make such films, which causes contamination in the deposited films. *Id.* at 2:25–30. The '657 patent further states that reactors for RF sputtering, particularly their power systems, are complicated. *Id.* at 2:30–38. The '657 patent discloses that reactive DC magnetron sputtering of nonconductive oxides is done rarely because insulating surfaces accumulate charge during deposition that results in arcing, damage to the sputtering power supply, and the production of particles that degrade the properties of deposited oxide films. *Id.* at 4:48–57.

Figure 1A of the '657 patent is reproduced below.

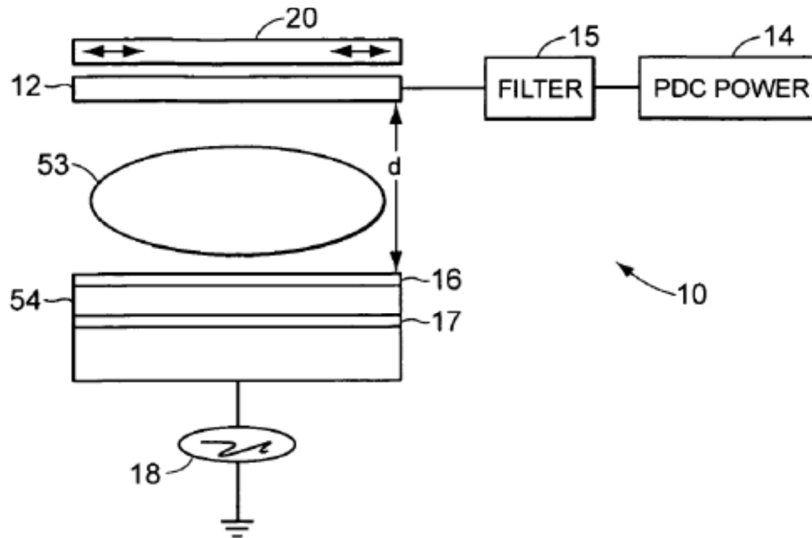

FIG. 1A

Figure 1A depicts a pulsed DC sputtering reactor.

The '657 patent describes reactor apparatus 10 for sputtering material from target 12. *Id.* at 5:13–15. Magnet 20 is used to scan across the top of target 12, which reduces local erosion of target 12 during sputtering. *Id.* at 5:35, 8:57–66. Substrate 16 is opposite and parallel to target 12. *Id.* at 5:29–30. Substrate 16 is capacitively coupled to electrode 17 via insulator 54. *Id.* at 5:32–36. Electrode 17 can be coupled to RF power supply 18. *Id.* at 5:34–35. The '657 patent explains that RF power supply 18 is used to avoid columnar structures in a deposited film, which can be detrimental for optical wave guide applications. *Id.* at 5:66–6:6. The '657 patent discloses that target 12 functions as a cathode when power is applied to target 12, which creates plasma 53. *Id.* at 5:30–32.

Target 12 is electrically coupled through filter 15 to pulsed DC power supply 14. *Id.* at 5:25–26. The '657 patent discloses that the polarity of the power supplied to target 12 by pulsed DC power supply 14 oscillates between negative and positive potentials. *Id.* at 5:36–39. According to the

'657 patent, the insulating layer on the surface of target 12 discharges during the positive period, which prevents arcing. *Id.* at 5:39–41. The '657 patent discloses that the pulsing frequency must exceed a critical frequency, which depends on a target material, cathode current, and reverse time. *Id.* at 5:41–43.

Reactor apparatus 10 further includes filter 15, which prevents the RF power supply from coupling to pulsed DC power supply 14. *Id.* at 5:56–57. According to the '657 patent, filter 15 can be a rejection filter, such as a 2 MHz band rejection filter when a 2 MHz power supply is used for RF power supply 18. *Id.* at 5:57–61. The '657 patent discloses that the band width of filter 15 can be approximately 100 kHz. *Id.* at 5:61–63.

#### *B. Illustrative Claims*

Of the Challenged Claims, claims 1 and 2 are independent and are reproduced below with bracketed material and formatting added.

1[a]. A method of depositing a film on an insulating substrate, comprising:

[b] providing a process gas between a conductive target and the substrate;

[c] providing pulsed DC power to the target through a narrow band rejection filter such that the target alternates between positive and negative voltages;

[d] providing an RF bias at a frequency that corresponds to the narrow band rejection filter to the substrate;

[e] providing a magnetic field to the target; and

[f] reconditioning the target;

[g] wherein reconditioning the target includes reactive sputtering in the metallic mode and then reactive sputtering in the poison mode.

Ex. 1001, 23:2–14.

# Explore Litigation Insights

Docket Alarm provides insights to develop a more informed litigation strategy and the peace of mind of knowing you're on top of things.

## Real-Time Litigation Alerts



Keep your litigation team up-to-date with **real-time alerts** and advanced team management tools built for the enterprise, all while greatly reducing PACER spend.

Our comprehensive service means we can handle Federal, State, and Administrative courts across the country.

## Advanced Docket Research



With over 230 million records, Docket Alarm's cloud-native docket research platform finds what other services can't. Coverage includes Federal, State, plus PTAB, TTAB, ITC and NLRB decisions, all in one place.

Identify arguments that have been successful in the past with full text, pinpoint searching. Link to case law cited within any court document via Fastcase.

## Analytics At Your Fingertips



Learn what happened the last time a particular judge, opposing counsel or company faced cases similar to yours.

Advanced out-of-the-box PTAB and TTAB analytics are always at your fingertips.

## API

Docket Alarm offers a powerful API (application programming interface) to developers that want to integrate case filings into their apps.

## LAW FIRMS

Build custom dashboards for your attorneys and clients with live data direct from the court.

Automate many repetitive legal tasks like conflict checks, document management, and marketing.

## FINANCIAL INSTITUTIONS

Litigation and bankruptcy checks for companies and debtors.

## E-DISCOVERY AND LEGAL VENDORS

Sync your system to PACER to automate legal marketing.