

03/16/02  
J0658 U.S. PTO

25 Metro Drive  
Suite 700

San Jose  
California 95110

T: 408-453-9200  
F: 408-453-7979

Austin, TX  
Newport Beach, CA  
San Francisco, CA

skjerven morrill  
macpherson LLP

Docket No.: M-12245 US

J1017 U.S. PTO  
10/101863  
03/16/02

March 16, 2002

Box Patent Application  
Commissioner For Patents  
Washington, D. C. 20231

Enclosed herewith for filing is a patent application, as follows:

Inventor(s): Zhang, Hongmei; Narasimhan, Mukundan; Mullapudi, Ravi; and Demaray, Richard E.

Title: **Biased Pulse DC Reactive Sputtering of Oxide Films**

- X   Return Receipt Postcard
- X   This Transmittal Letter (in duplicate)
- 2   page(s) Declaration For Patent Application and Power of Attorney (unsigned)
- 34  page(s) Specification (not including claims)
- 4  page(s) Claims
- 1  page Abstract
- 27  Sheet(s) of Drawings

Applicant(s) assert(s) entitlement to small entity status for the attached patent application

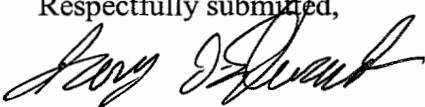
**CLAIMS AS FILED (fees computed under 37 CFR §1.9(f))**

For	Number Filed		Number Extra		Rate		Basic Fee	
Total Claims	39	-20 =	9	x	\$ 9.00 =	\$	370.00 81.00	
Independent Claims	5	-3 =	2	x	\$42.00 =	\$	84.00	
<input type="checkbox"/>	Fee of _____ for the first filing of one or more multiple dependent claims per application						\$	
<input type="checkbox"/>	Fee for Request for Extension of Time						\$	

Please make the following charges to Deposit Account 19-2386:

- Total fee for filing the patent application in the amount of \$ 525.00
- The Commissioner is hereby authorized to charge any additional fees which may be required, or credit any overpayment to Deposit Account 19-2386.

EXPRESS MAIL LABEL NO:  
EL 941 069 152 US

Respectfully submitted,  
  
Gary J. Edwards  
Attorney for Applicant(s)  
Reg. No. 41,008

## Biased Pulse DC Reactive Sputtering of Oxide Films

Hongmei Zhang  
Mukundan Narasimhan  
Ravi Mullapudi  
Richard E. Demaray

### Background

#### 1. Field of the Invention

[0001] The present invention relates to deposition of oxide and oxynitride films and, in particular, to deposition of oxide and oxynitride films by pulsed DC reactive sputtering.

#### 2. Discussion of Related Art

[0002] Deposition of insulating materials and especially optical materials is technologically important in several areas including production of optical devices and production of semiconductor devices. In semiconductor devices, doped alumina silicates can be utilized as high dielectric insulators.

[0003] The increasing prevalence of fiber optic communications systems has created an unprecedented demand for devices for processing optical signals. Planar devices such as optical waveguides, couplers, splitters, and amplifiers, fabricated on planar substrates, like those commonly used for integrated circuits, and configured to receive and process signals from optical fibers are highly desirable. Such devices hold promise for integrated optical and electronic signal processing on a single semiconductor-like substance.

[0004] The basic design of planar optical waveguides and amplifiers is well known, as described, for example, in U. S. Patent Nos. 5,119,460 and 5,563,979 to Bruce et al., 5,613,995 to Bhandarkar et al., 5,900,057 to Buchal et al., and 5,107,538 to Benton et al., to cite only a few. These devices, very generally, include a core region, typically bar shaped, of a certain refractive index surrounded by a cladding region of a lower refractive index. In the case of an optical amplifier, the core region includes a certain concentration of a dopant, typically a rare earth ion

such as an erbium or praseodymium ion which, when pumped by a laser, fluoresces, for example, in the 1550 nm and 1300 nm wavelength ranges used for optical communication, to amplify the optical signal passing through the core.

[0005] As described, for example in the patents by Bruce et al., Bhandarkar et al., and Buchal et al., planar optical devices may be fabricated by process sequences including forming a layer of cladding material on a substrate; forming a layer of core material on the layer of cladding mater; patterning the core layer using a photolithographic mask and an etching process to form a core ridge; and covering the core ridge with an upper cladding layer.

[0006] The performance of these planar optical devices depends sensitively on the value and uniformity of the refractive index of the core region and of the cladding region, and particularly on the difference in refractive index,  $\Delta n$ , between the regions. Particularly for passive devices such as waveguides, couplers, and splitters,  $\Delta n$  should be carefully controlled, for example to values within about 1 %, and the refractive index of both core and cladding need to be highly uniform, for some applications at the fewer than parts per thousand level. In the case of doped materials forming the core region of planar optical amplifiers, it is important that the dopant be uniformly distributed so as to avoid non-radiative quenching or radiative quenching, for example by upconversion. The refractive index and other desirable properties of the core and cladding regions, such as physical and chemical uniformity, low stress, and high density, depend, of course, on the choice of materials for the devices and on the processes by which they are fabricated.

[0007] Because of their optical properties, silica and refractory oxides such as  $Al_2O_3$ , are good candidate materials for planar optical devices. Further, these oxides serve as suitable hosts for rare earth dopants used in optical amplifiers. A common material choice is so-called low temperature glasses, doped with alkali metals, boron, or phosphorous, which have the advantage of requiring lower processing temperatures. In addition, dopants are used to modify the refractive index. Methods such as flame hydrolysis, ion exchange for introducing alkali ions in glasses, sputtering, and various chemical vapor deposition processes (CVD) have been used to form films of doped glasses. However, dopants such as phosphorous and boron are hygroscopic, and alkalis are undesirable for integration with electronic devices. Control of uniformity of doping in CVD processes can be difficult and CVD deposited films can have structural defects

leading to scattering losses when used to guide light. In addition, doped low temperature glasses may require further processing after deposition. A method for eliminating bubbles in thin films of sodium-boro-silicate glass by high temperature sintering is described, for example, in the '995 patent to Bhandarkar et al.

[0008] Typically, RF sputtering has been utilized for deposition of oxide dielectric films. However, RF sputtering utilizes ceramic targets which are typically formed of multiple smaller tiles. Since the tiles can not be made very large, there may be a large problem of arcing between tiles and therefore contamination of the deposited film due to this arcing. Further, the reactors required for RF sputtering tend to be rather complicated. In particular, the engineering of low capacitance efficient RF power distribution to the cathode is difficult in RF systems. Routing of low capacitance forward and return power into a vacuum vessel of the reaction chamber often exposes the power path in such a way that diffuse plasma discharge is allowed under some conditions of impedance tuning of the matching networks.

[0009] Therefore, there is a need for new methods of depositing oxide and oxynitride films and for forming planar optical devices.

### Summary

[0010] In accordance with the present invention, a sputtering reactor apparatus for depositing oxide and oxynitride films is presented. Further, methods for depositing oxide and oxynitride films for optical waveguide devices are also presented. A sputtering reactor according to the present invention includes a pulsed DC power supply coupled through a filter to a target and a substrate electrode coupled to an RF power supply. A substrate mounted on the substrate electrode is therefore supplied with a bias from the RF power supply.

[0011] The target can be a metallic target made of a material to be deposited on the substrate. In some embodiments, the metallic target is formed from Al, Si and various rare-earth ions. A target with an erbium concentration, for example, can be utilized to deposit a film that can be formed into a waveguide optical amplifier.

[0012] A substrate can be any material and, in some embodiments, is a silicon wafer. In some

embodiments, RF power can be supplied to the wafer. In some embodiments, the wafer and the electrode can be separated by an insulating glass.

[0013] In some embodiments, up to about 10 kW of pulsed DC power at a frequency of between about 40 kHz and 350 kHz and a reverse pulse time of up to about 5  $\mu$ s is supplied to the target. The wafer can be biased with up to about several hundred watts of RF power. The temperature of the substrate can be controlled to within about 10° C and can vary from about -50° C to several hundred degrees C. Process gasses can be fed into the reaction chamber of the reactor apparatus. In some embodiments, the process gasses can include combinations of Ar, N<sub>2</sub>, O<sub>2</sub>, C<sub>2</sub>F<sub>6</sub>, CO<sub>2</sub>, CO and other process gasses.

[0014] Several material properties of the deposited layer can be modified by adjusting the composition of the target, the composition and flow rate of the process gasses, the power supplied to the target and the substrate, and the temperature of the substrate. For example, the index of refraction of the deposited layer depends on deposition parameters. Further, in some embodiments stress can be relieved on the substrate by depositing a thin film of material on a back side of the wafer. Films deposited according to the present invention can be utilized to form optical waveguide devices such as multiplexers and rare-earth doped amplifiers.

[0015] These and other embodiments, along with examples of material layers deposited according to the present invention, are further described below with respect to the following figures.

#### **Brief Description of the Figures**

[0016] Figures 1A and 1B show a pulsed DC sputtering reactor according to the present invention.

[0017] Figure 2 shows a planar view of target utilized in a reactor as shown in Figures 1A and 1B.

[0018] Figure 3 shows a cross-section view of an example target utilized in a reactor as shown in Figures 1A and 1B.

[0019] Figure 4 shows a flow chart of an embodiment of a process for depositing a film on a substrate according to the present invention.

[0020] Figure 5 shows a hysteresis curve of target voltage versus oxygen flow rates for an example target in an embodiment of a reactor according to the present invention.

[0021] Figure 6 shows a photo-luminescence and lifetimes of a film deposited in a process according to the present invention as a function of after deposition anneal temperature.

[0022] Figure 7 shows the relationship between the index of refraction of a film as a function of deposited oxide layers according to the present invention and due to oxide build-up on the target.

[0023] Figure 8 shows a graph of the index of refraction of a film deposited according to the present invention as a function of the aluminum content in a composite Al/Si target.

[0024] Figure 9 shows a graph of typical indices of refraction of material layers deposited according to the present invention.

[0025] Figure 10 shows a table of indices of refraction for a silica layer deposited according to the present invention as a function of different process parameters.

[0026] Figure 11 shows the refractive indices as a function of O<sub>2</sub>/Ar ratio utilized in an Alumina process according to the present invention.

[0027] Figure 12 shows the refractive indices as a function of DC pulsed power frequency for an Alumina layer deposited according to the present invention.

[0028] Figure 13 shows variation in the refractive index over time during repeated depositions from a single target.

[0029] Figure 14 shows variation in refractive index over time for repeated depositions from a target of another material layer according to the present invention.

[0030] Figure 15 shows the variation refractive index over time for repeated depositions from a target of another material layer according to the present invention.

[0031] Figure 16A through 16D shows a TEM film deposited according to the present invention.

[0032] Figure 17 shows the transparency of a film deposited according to the present invention.

[0033] Figure 18 shows an uppercladding layer deposited according to the present invention over a multiple-waveguide structure such that the deposited layer is substantially planarized.

[0034] Figure 19 illustrates the deposition of a film over a waveguide structure.

[0035] Figures 20 and 21 illustrate different etch and deposition rates for deposition of films as a function of the surface angle of the film.

[0036] Figure 22 illustrates calculation of the planarization time for a particular deposition process.

[0037] Figures 23 through 25 through illustrate adjustment of process parameters in order to achieve planarization of a film deposited over a waveguide structure according to the present invention.

[0038] Figure 26 shows the gain characteristics of an erbium doped waveguide amplifier formed of films depositions according to the present invention.

[0039] Figures 27 shows gain, insertion loss of a waveguide with an active core deposited according to the present invention.

[0040] Figure 28 shows up-conversion constants, and lifetimes of the active core layer of Figure 27 deposited according to the present invention.

[0041] Figure 29 shows drift in the index of refraction with subsequent depositions for films deposited from a target according to the present invention.

[0042] Figure 30 shows drift in the photoluminescence with subsequent depositions according to the present invention.

[0043] Figure 31 shows drift in the excited state lifetime with subsequent depositions according to the present invention.

[0044] Figure 32 shows stabilization of the index of refraction in subsequent depositions.

[0045] Figure 33 shows the index of refraction of a film formed from a pure silicon target as a

function of the ratio of  $O_2/N_2$  in the process gas.

[0046] In the figures, elements having the same designation have the same or similar function.

### Detailed Description

[0047] Reactive DC magnetron sputtering of nitrides and carbides is a widely practiced technique, but the reactive dc magnetron sputtering of nonconducting oxides is done rarely. Films such as aluminum oxide are almost impossible to deposit by conventional reactive DC magnetron sputtering due to rapid formation of insulating oxide layers on the target surface. The insulating surfaces charges up and result in arcing during process. This arcing can damage the power supply, produce particles and degrade the properties of deposited oxide films.

[0048] RF sputtering of oxide films is discussed in Application Serial No. 09/903,050 (the '050 application) by Demaray et al., entitled "Planar Optical Devices and Methods for Their Manufacture," assigned to the same assignee as is the present invention, herein incorporated by reference in its entirety. Further, targets that can be utilized in a reactor according to the present invention are discussed in U.S. Application serial no. {Attorney Docket No. M-12247 US} (the '247 application), filed concurrently with the present disclosure, assigned to the same assignee as is the present invention, herein incorporated by reference in its entirety. A gain-flattened amplifier formed of films deposited according to the present invention are described in U.S. Application serial no. {Attorney Docket No. M-12652 US} (the '652 application), filed concurrently with the present disclosure, assigned to the same assignee as is the present invention, herein incorporated by reference in its entirety. Further, a mode size converter formed with films deposited according to the present invention is described in U.S. Application serial no. {Attorney Docket No. M-12138 US} (the '138 application), filed concurrently with the present disclosure, assigned to the same assignee as is the present invention, herein incorporated by reference in its entirety.

[0049] Figure 1A shows a schematic of a reactor apparatus 10 for sputtering of material from a target 12 according to the present invention. In some embodiments, apparatus 10 may, for



example, be adapted from an AKT-1600 PVD (400 X 500 mm substrate size) system from Applied Komatsu or an AKT-4300 (600 X 720 mm substrate size) system from Applied Komatsu, Santa Clara, CA. The AKT-1600 reactor, for example, has three deposition chambers connected by a vacuum transport chamber. These Komatsu reactors can be modified such that pulsed DC power is supplied to the target and RF power is supplied to the substrate during deposition of a material film.

[0050] Apparatus 10 includes a target 12 which is electrically coupled through a filter 15 to a pulsed DC power supply 14. In some embodiments, target 12 is a wide area sputter source target, which provides material to be deposited on substrate 16. Substrate 16 is positioned parallel to and opposite target 12. Target 12 functions as a cathode when power is applied to it and is equivalently termed a cathode. Application of power to target 12 creates a plasma 53. Substrate 16 is capacitively coupled to an electrode 17 through an insulator 54. Electrode 17 can be coupled to an RF power supply 18. Magnet 20 is scanned across the top of target 12.

[0051] For pulsed reactive dc magnetron sputtering, as performed by apparatus 10, the polarity of the power supplied to target 12 by power supply 14 oscillates between negative and positive potentials. During the positive period, the insulating layer on the surface of target 12 is discharged and arcing is prevented. To obtain arc free deposition, the pulsing frequency exceeds a critical frequency that depend on target material, cathode current and reverse time. High quality oxide films can be made using reactive pulse DC magnetron sputtering in apparatus 10.

[0052] Pulsed DC power supply 14 can be any pulsed DC power supply, for example an AE Pinnacle plus 10K by Advanced Energy, Inc. With this example supply, up to 10 kW of pulsed DC power can be supplied at a frequency of between 0 and 350 KHz. The reverse voltage is 10% of the negative target voltage. Utilization of other power supplies will lead to different power characteristics, frequency characteristics and reverse voltage percentages. The reverse time on this embodiment of power supply 14 can be adjusted between 0 and 5  $\mu$ s.

[0053] Filter 15 prevents the bias power from power supply 18 from coupling into pulsed DC power supply 14. In some embodiments, power supply 18 is a 2 MHz RF power supply, for example can be a Nova-25 power supply made by ENI, Colorado Springs, Co.

[0054] Therefore, filter 15 is a 2 MHz band rejection filter. In some embodiments, the band

width of the filter can be approximately 100 kHz. Filter 15, therefore, prevents the 2 MHz power from the bias to substrate 16 from damaging power supply 18.

[0055] However, both RF and pulsed DC deposited films are not fully dense and most likely have columnar structures. These columnar structures are detrimental for optical wave guide applications due to the scattering loss caused by the structure. By applying a RF bias on wafer 16 during deposition, the deposited film can be dandified by energetic ion bombardment and the columnar structure can be substantially eliminated.

[0056] In the AKT-1600 based system, for example, target 12 can have an active size of about 675.70 X 582.48 by 4 mm in order to deposit films on substrate 16 that have dimension about 400 X 500 mm. The temperature of substrate 16 can be held at between -50C and 500C. The distance between target 12 and substrate 16 can be between about 3 and about 9 cm. Process gas can be inserted into the chamber of apparatus 10 at a rate up to about 200 sccm while the pressure in the chamber of apparatus 10 can be held at between about .7 and 6 millitorr. Magnet 20 provides a magnetic field of strength between about 400 and about 600 Gauss directed in the plane of target 12 and is moved across target 12 at a rate of less than about 20-30 sec/scan. In some embodiments utilizing the AKT 1600 reactor, magnet 20 can be a race-track shaped magnet with dimension about 150 mm by 600 mm.

[0057] A top down view of magnet 20 and wide area target 12 is shown in Figure 2. A film deposited on a substrate positioned on carrier sheet 17 directly opposed to region 52 of target 12 has good thickness uniformity. Region 52 is the region shown in Figure 1B that is exposed to a uniform plasma condition. In some implementations, carrier 17 can be coextensive with region 52. Region 24 shown in Figure 2 indicates the area below which both physically and chemically uniform deposition can be achieved, where physical and chemical uniformity provide refractive index uniformity, for example. Figure 2 indicates that region 52 of target 12 that provides thickness uniformity is, in general, larger than region 24 of target 12 providing thickness and chemical uniformity. In optimized processes, however, regions 52 and 24 may be coextensive.

[0058] In some embodiments, magnet 20 extends beyond area 52 in one direction, the Y direction in Figure 2, so that scanning is necessary in only one direction, the X direction, to provide a time averaged uniform magnetic field. As shown in Figures 1A and 1B, magnet 20 can be scanned over the entire extent of target 12, which is larger than region 52 of uniform

sputter erosion. Magnet 20 is moved in a plane parallel to the plane of target 12.

[0059] The combination of a uniform target 12 with a target area 52 larger than the area of substrate 16 can provide films of highly uniform thickness. Further, the material properties of the film deposited can be highly uniform. The conditions of sputtering at the target surface, such as the uniformity of erosion, the average temperature of the plasma at the target surface and the equilibration of the target surface with the gas phase ambient of the process are uniform over a region which is greater than or equal to the region to be coated with a uniform film thickness. In addition, the region of uniform film thickness is greater than or equal to the region of the film which is to have highly uniform optical properties such as index of refraction, density, transmission or absorptivity.

[0060] Target 12 can be formed of any materials, but is typically metallic materials such as, for example, combinations of Al and Si. Therefore, in some embodiments, target 12 includes a metallic target material formed from intermetallic compounds of optical elements such as Si, Al, Er and Yb. Additionally, target 12 can be formed, for example, from materials such as La, Yt, Ag, Au, and Eu. To form optically active films on substrate 16, target 12 can include rare-earth ions. In some embodiments of target 12 with rare earth ions, the rare earth ions can be pre-alloyed with the metallic host components to form intermetallics. See the '247 application.

[0061] In several embodiments of the invention, material tiles are formed. These tiles can be mounted on a backing plate to form a target for apparatus 10. Figure 3A shows an embodiment of target 12 formed with individual tiles 30 mounted on a cooled backplate 25. In order to form a wide area target of an alloy target material, the consolidated material of individual tiles 30 should first be uniform to the grain size of the powder from which it is formed. It also should be formed into a structural material capable of forming and finishing to a tile shape having a surface roughness on the order of the powder size from which it is consolidated. A wide area sputter cathode target can be formed from a close packed array of smaller tiles. Target 12, therefore, may include any number of tiles 30, for example between 2 to 20 individual tiles 30. Tiles 30 are finished to a size so as to provide a margin of non-contact, tile to tile, 29 in Figure 3A, less than about 0.010" to about 0.020" or less than half a millimeter so as to eliminate plasma processes between adjacent ones of tiles 30. The distance between tiles 30 of target 12 and the dark space anode or ground shield 19, in Figure 1B can be somewhat larger so as to provide non contact assembly or provide for thermal expansion tolerance during process chamber conditioning or

operation.

[0062] Several useful examples of target 12 that can be utilized in apparatus 10 according to the present invention include the following targets compositions: (Si/Al/Er/Yb) being about (57.0/41.4/0.8/0.8), (48.9/49/1.6/0.5), (92/8/0/0), (60/40/0/0), (50/50/0/0), (65/35/0/0), (70/30/0,0), and (50,48.5/1.5/0) cat. %, to list only a few. These targets can be referred to as the 0.8/0.8 target, the 1.6/.5 target, the 92-8 target, the 60-40 target, the 50-50 target, the 65-35 target, the 70-30 target, and the 1.5/0 target, respectively. The 0.8/0.8, 1.6/0.5, and 1.5/0 targets can be made by pre-alloyed targets formed from an atomization and hot-isostatic pressing (HIPing) process as described in the '247 application. The remaining targets can be formed, for example, by HIPing. Targets formed from Si, Al, Er and Yb can have any composition. In some embodiments, the rare earth content can be up to 10 cat. % of the total ion content in the target. Rare earth ions are added to form active layers for amplification. Targets utilized in apparatus 10 can have any composition and can include ions other than Si, Al, Er and Yb, including: Zn, Ga, Ge, P, As, Sn, Sb, Pb, Ag, Au, and rare earths: Ce, Pr, Nd, Pm, Sm, Eu, Gd, Tb, Dy Ho, Er, Tm Yb and Lu.

[0063] Optically useful materials to be deposited onto substrate 16 include oxides, fluorides, sulfides, nitrides, phosphates, sulfates, and carbonates, as well as other wide band gap semiconductor materials. To achieve uniform deposition, target 12, itself can be chemically uniform and of uniform thickness over an extended area.

[0064] Target 12 can be a composite target fabricated from individual tiles, precisely bonded together on a backing plate with minimal separation, as is discussed further with respect to Figure 3. In some embodiments, the mixed intermetallics can be plasma sprayed directly onto a backing plate to form target 12. The complete target assembly can also includes structures for cooling the target, embodiments of which have been described in U. S. Patent No. 5,565,071 to Demaray et al, and incorporated herein by reference.

[0065] Substrate 16 can be a solid, smooth surface. Typically, substrate 16 can be a silicon wafer or a silicon wafer coated with a layer of silicon oxide formed by a chemical vapor deposition process or by a thermal oxidation process. Alternatively, substrate 16 can be a glass, such as Corning 1737 (Corning Inc., Elmira, NY), a glass-like material, quartz, a metal, a metal oxide, or a plastic material. Substrate 16 can be supported on a holder or carrier sheet that may

be larger than substrate 16. Substrate 16 can be electrically biased by power supply 18.

[0066] In some embodiments, the area of wide area target 12 can be greater than the area on the carrier sheet on which physically and chemically uniform deposition is accomplished. Secondly, in some embodiments a central region on target 12, overlying substrate 16, can be provided with a very uniform condition of sputter erosion of the target material. Uniform target erosion is a consequence of a uniform plasma condition. In the following discussion, all mention of uniform condition of target erosion is taken to be equivalent to uniform plasma condition. Uniform target erosion is evidenced by the persistence of film uniformity throughout an extended target life. A uniformly deposited film can be defined as a film having a nonuniformity in thickness, when measured at representative points on the entire surface of a substrate wafer, of less than about 5 % or 10%. Thickness nonuniformity is defined, by convention, as the difference between the minimum and maximum thickness divided by twice the average thickness. If films deposited from a target from which more than about 20 % of the weight of the target has been removed continue to exhibit thickness uniformity, then the sputtering process is judged to be in a condition of uniform target erosion for all films deposited during the target life.

[0067] As shown in Figure 1B, a uniform plasma condition can be created in the region between target 12 and substrate 16 in a region overlying substrate 16. A plasma 53 can be created in region 51, which extends under the entire target 12. A central region 52 of target 12, can experience a condition of uniform sputter erosion. As discussed further below, a layer deposited on a substrate placed anywhere below central region 52 can then be uniform in thickness and other properties (i.e., dielectric, optical index, or material concentrations).

[0068] In addition, region 52 in which deposition provides uniformity of deposited film can be larger than the area in which the deposition provides a film with uniform physical or optical properties such as chemical composition or index of refraction. In some embodiments, target 12 is substantially planar in order to provide uniformity in the film deposited on substrate 16. In practice, planarity of target 12 can mean that all portions of the target surface in region 52 are within a few millimeters of a planar surface, and can be typically within 0.5 mm of a planar surface.

[0069] Other approaches to providing a uniform condition of sputter erosion rely on creating a large uniform magnetic field or a scanning magnetic field that produces a time-averaged,

uniform magnetic field. For example, rotating magnets or electromagnets can be utilized to provide wide areas of substantially uniform target erosion. For magnetically enhanced sputter deposition, a scanning magnet magnetron source can be used to provide a uniform, wide area condition of target erosion.

[0070] As illustrated in FIG. 1A, apparatus 10 can include a scanning magnet magnetron source 20 positioned above target 12. An embodiment of a scanning magnetron source used for dc sputtering of metallic films is described in U. S. Patent No. 5,855,744 to Halsey, et. al., (hereafter '744), which is incorporated herein by reference in its entirety. The '744 patent demonstrates the improvement in thickness uniformity that is achieved by reducing local target erosion due to magnetic effects in the sputtering of a wide area rectangular target. As described in the '744 patent, by reducing the magnetic field intensity at these positions, the local target erosion was decreased and the resulting film thickness nonuniformity was improved from 8%, to 4%, over a rectangular substrate of 400 x 500 mm.

[0071] The process gas utilized in reactor 10 includes an inert gas, typically argon, used as the background sputtering gas. Additionally, with some embodiments of target 12, reactive components such as, for example, oxygen may be added to the sputtering gas. Other gasses such as N<sub>2</sub>, NH<sub>3</sub>, CO, NO, CO<sub>2</sub>, halide containing gasses other gas-phase reactants can also be utilized. The deposition chamber can be operated at low pressure, often between about .5 millitorr and 8-10 millitorr. Typical process pressure is below about 3-5 millitorr where there are very few collisions in the gas phase, resulting in a condition of uniform "free molecular" flow. This ensures that the gas phase concentration of a gaseous component is uniform throughout the process chamber. For example, background gas flow rates in the range of up to about 200 sccm, used with a pump operated at a fixed pumping speed of about 50 liters/second, result in free molecular flow conditions.

[0072] The distance d, in Figure 1A, between target 12 and substrate 16 can, in some embodiments, be varied between about 4 cm and about 9 cm. A typical target to substrate distance d is about 6 cm. The target to substrate distance can be chosen to optimize the thickness uniformity of the film. At large source to substrate distances the film thickness distribution is dome shaped with the thickest region of the film at the center of the substrate. At close source to substrate distance the film thickness is dish shaped with the thickest film formed at the edge of the substrate. The substrate temperature can be held constant in the range of about -40 °C to

about 550°C and can be maintained at a chosen temperature to within about 10 °C by means of preheating substrate 16 and the substrate holder prior to deposition. During the course of deposition, the heat energy impressed upon the substrate by the process can be conducted away from substrate 16 by cooling the table on which substrate 16 is positioned during the process, as known to those skilled in the art. The process is performed under conditions of uniform gas introduction, uniform pumping speed, and uniform application of power to the periphery of the target as known to skilled practitioners.

[0073] The speed at which a scanning magnet 20 can be swept over the entire target can be determined such that a layer thickness less than about 5 to 10 Å, corresponding roughly to two to four monolayers of material, is deposited on each scan. Magnet 20 can be moved at rates up to about 30 sec/one-way scan and typically is moved at a rate of about 4 sec/one-way scan. The rate at which material is deposited depends on the applied power and on the distance d, in Figure 1A, between the target 12 and the substrate 16. For deposition of optical oxide materials, for example scanning speeds between about 2 sec/one-way scan across the target to 20-30 sec/scan provide a beneficial layer thickness. Limiting the amount of material deposited in each pass promotes chemical and physical uniformity of the deposited layer.

[0074] Substrate bias has been used previously to planarize RF sputtered deposited quartz films. A theoretical model of the mechanism by which substrate bias operates, has been put forward by Ting et al. (*J. Vac. Sci. Technol.* 15, 1105 (1978)). When power is applied to the substrate, a so-called plasma sheath is formed about the substrate and ions are coupled from the plasma. The sheath serves to accelerate ions from the plasma so that they bombard the film as it is deposited, sputtering the film, and forward scattering surface atoms, densifying the film and eliminating columnar structure. The effects of adding substrate bias are akin to, but more dramatic than, the effects of adding the low frequency RF component to the sputter source.

[0075] Biasing substrate 16 results in the deposited film being simultaneously deposited and etched. The net accumulation of film at any point on a surface depends on the relative rates of deposition and etching, which depend respectively, on the power applied to the target and to the substrate, and to the angle that the surface makes with the horizontal. The rate of etching is greatest for intermediate angles, on the order of 45 degrees, that is between about 30 and 60 degrees.

[0076] Powers to target 12 and substrate 16 can be adjusted such that the rates of deposition and etching are approximately the same for a range of intermediate angles. In this case, films deposited with bias sputtering have the following characteristics. At a step where a horizontal surface meets a vertical surface, the deposited film makes an intermediate angle with the horizontal. On a surface at an intermediate angle, there will be no net deposition since the deposition rate and etch rate are approximately equal. There is net deposition on a vertical surface.

[0077] Target 12 can have an active size of about 675.70 X 582.48 by 4 mm, for example, in a AKT-1600 based system in order to deposit films on a substrate 16 that is about 400 X 500 mm. The temperature of substrate 16 can be held at between -50C and 500C. The distance between target 12 and substrate 16 can be between 3 and 9 cm. Process gas can be inserted into the chamber of apparatus 10 at a rate of between about 30 to about 100 sccm while the pressure in the chamber of apparatus 10 can be held at below about 2 millitorr. Magnet 20 provides a magnetic field of strength between about 400 and about 600 Gauss directed in the plane of target 12 and is moved across target 12 at a rate of less than about 20-30 sec/scan.

[0078] Therefore, any given process utilizing apparatus 10 can be characterized by providing the power supplied to target 12, the power supplied to substrate 16, the temperature of substrate 16, the characteristics and constituents of the reactive gasses, the speed of the magnet, and the spacing between substrate 16 and target 12.

[0079] Sputtered oxide films according to some embodiments of the present invention can be deposited onto a Si wafer or thermal oxide wafers at pressure of between about 3 and about 6 mTorr. The ratio of O<sub>2</sub>/Ar gas flow can be set at a value to ensure that target 12 is operating within a poison mode. The poison mode is defined as the ratio where the oxide is etched from the surface of target 12 as fast as the oxide layer is formed. Operating in the poison mode results in the stoichiometric film. Sub-stoichiometric oxides may not be optically transparent. The pulsing frequency range for power supply 14 can be from about up to about 250 KHz. The frequency 40 KHz is approximately the lowest frequency at which no arcing will occur during deposition in, for example, the AKT 1600 based system. The reverse pulsing time is determined by the amount of arcing generated during the process. Longer reverse time means longer discharge time and thus less arcs. However, if the reverse time is too long, the deposition rate will decrease. Power supply 18 is a 2 MHz RF power supply operated at powers up to several



hundred Watts.

[0080] Figure 4 shows an embodiment of a process procedure 400 performed on apparatus 10. In step 401, the target is prepared for the deposition. In some embodiments, target 12 can be cleaned by pure Ar sputtering. In other words, apparatus 10 is operated with pure Ar gas only (referred to as the metal mode) in order to sputter away a surface layer of target 12.

[0081] Figure 7 shows the typical drift in the index of refraction with deposition of oxide layers for several different targets over different runs for each target. In Figure 7, the compositions of the target materials utilized in target 12 for the depositions shown are as follows: Si: 60 cat. % and Al: 40 cat. %; Si: 50 cat. % and Al: 50 cat. %; Si: 85 cat. % and Al: 15 cat. %; Si: 35 cat. % and Al: 65 cat. %; and Si: 92 cat. % and 8 cat. %. Each deposition was operated under the same process parameters: 4.5 kW of pulsed DC power at 200 kHz with a reverse time of 2.3  $\mu$ s applied to target 12, O<sub>2</sub> flow at 44 sccm, Ar flow at 30 sccm introduced to apparatus 10, 100 W of bias power at 2 MHz applied to substrate 16, the temperature of substrate 16 held at 200° C, and the distance between substrate 16 and target 12 being set at 6 cm. For each target measured, the index drifted up during repeated utilization.

[0082] Figure 8 shows the relationship between the index of refraction of a film deposited according to the present invention and the amount of aluminum in the composite target. As can be seen from Figure 8, the index of refraction of the deposited film depends strongly on the aluminum content. Therefore, as the aluminum in a metal target is depleted, the index of refraction drifts. In some embodiments, the ratio of Ar and O<sub>2</sub> utilized in the process can be maintained to provide films of uniform index over a large number of depositions on the target.

[0083] Reactive sputtering from a metal or metallic alloy target 12 can be characterized by two modes of operation. In the first mode, which is sometimes referred to as the 'metallic mode' the surface of target 12 is substantially metallic. This mode is characterized by a small addition of reactive gas to the inert gas flow of apparatus 10 as well as a higher impedance magnetron discharge. It is also characterized by incomplete oxidation of film deposited on substrate 16 and therefore higher index films. As the proportion of reactive to inert gas is increased, the sputter voltage at target 12 begins to fall at constant power.

[0084] Figure 5 shows the voltage on target 12 of an embodiment of apparatus 10 according to

the present invention as a function of process gas constitution. In the example illustrated in Figure 5, for example, a metallic target with composition .8 cat. % Er, .8 cat. % Yb, 57.4 cat. % Si and 41 cat. % Si, which can be formed as described in the '247 application, was sputtered in an embodiment of apparatus 10 based on the AKT-1600 PVD system with 6 kW of pulsed DC power at a frequency of 120 kHz and a reverse time of 2.3 micro seconds. The Argon gas flow was set at 60 sccm and the Oxygen gas flow was varied from zero up to 40 sccm. For more details regarding this deposition, see Example 1 below.

[0085] As shown in Figure 5, the voltage on target 12 during deposition (the "target voltage") was constant at about 420 Volts for oxygen flow rates up to about 20 sccm. This is clearly the metallic mode of operation for this embodiment of target 12. Films deposited in this range of oxygen flow are characterized as metallic with an oxygen content that increases with oxygen flow rate during deposition. As the oxygen flow is increased up to about 26 sccm, the voltage on target 12 begins to decrease, indicating that the surface of target 12 is beginning to form an oxide layer. The oxide layer on the surface of target 12 has a higher secondary electron yield under the influence of the Argon ion flux. The additional electron flux to the magnetron electron trap increases the ion production in the plasma, which, in turn, decreases the impedance of the plasma discharge in apparatus 10.

[0086] At slightly higher oxygen flow during deposition, the oxide layer on target 12 forms a continuous layer and the voltage of target 12 during deposition falls rapidly to the range of about 190 to about 270 Volts, indicating complete coverage of the surface of target 12 with an oxide that is at least as thick as the material removed during one scan of the magnetron. Under this condition, the rate of oxide formation on the surface of target 12 equals or exceeds the rate of sputter removal of the surface of target 12 by the moving magnetron 20. This condition is sometimes referred to as the 'poisoned mode'.

[0087] Under steady state DC voltage conditions, the oxide layer on target 12 soon charges up, leading to reduced rate of sputtering and increased micro-arc discharging in apparatus 10. This discharging leads to particulation of the oxide layer on target 12, which degrades the quality of a film deposited on substrate 16. In the example shown with Figure 5, the negative going DC Voltage is reduced at a frequency of 120 kHz to a positive value for a period of about 2.3 micro seconds per cycle, allowing charge neutralization of the surface of target 12, increasing the steady state sputter and deposition rates as well as decreasing the rate of micro-arcing.

[0088] In the case of a magnetron configuration of magnet 20 having a significant deep local target erosion (rather than a configuration of magnet 20 described above which yields uniform target erosion), the change in the target voltage of target 12 is more gradual with increasing oxygen flow since it is more difficult to establish an oxide condition at the center of an intense region of local erosion. The resulting deposited film, however, will be rich in metallic sputtered flux to the substrate in the region of higher sputter erosion, leading to non uniform stoichiometry and non-uniform indices of refraction in a film deposited on substrate 16. In the case of a scanning magnetron 20 with uniform target erosion, the change in the surface condition from metallic to poisoned is more abrupt, as the formation rate of the oxide increases to equal the sputter removal of the oxide over a wide area of the target. In this case, there is uniform distribution of sputtered oxide from the target. Uniform stoichiometry and uniform indices of refraction result for the film deposited on substrate 16.

[0089] Figure 8 shows the range of indices of refraction of films deposited for targets of differing silica and alumina compositions, as deposited and after a subsequent anneal step. In the case of a pure silicon target, the as-deposited index of refraction can be as high as 3.4 for pure amorphous silicon. In Figure 8, pure silica films (zero Al%) can be deposited with a reactive pulsed DC and substrate bias deposition according to the present invention with substantially complete oxygen stoichiometry, so as to approximate monolithic amorphous silica. The index of refraction of such films decreases with a subsequent heat treatment of between about 700-900° C, indicating somewhat more complete oxidation reaction of the material of the film together with some degree of stress relaxation of the film deposited on substrate 16.

[0090] At the opposite extreme, a pure aluminum embodiment of target 12 (100% Al) can be utilized to deposit films on substrate 16 under similar process conditions as is utilized to deposit pure silica films on substrate 16. In the case of the pure aluminum reactive deposition, the dependence of the index of refraction of the film deposited on substrate 16 on oxygen flow as well as on the frequency of the pulsed DC process can be examined. As a result, a larger range of effective index of refraction is achieved together with a reduced or zero dependence of the index on the subsequent anneal process. Six targets having differing aluminum composition were utilized to evaluate the index of refraction of sputtered films on substrate 16 of related composition. The largest change of index with the sputtering conditions is achieved for composition near the middle of the Al/Si composition range (about 50% Al and 50% Si).

[0091] Figure 7 shows the change in film index for oxide films for several embodiments of target 12 and processes with an initial 30 minutes of Argon only sputtering, followed by continuous deposition with an oxygen flow rate sufficient for operation in the poisonous mode. Note that the rate of increase in the index of refraction of a resulting film deposited on substrate 16 with continuous poisoned mode deposition is proportional to the concentration of aluminum in the composition of target 12. This result is due to the depletion of the aluminum from the target surface during the metallic sputtering or pre-condition process. The aluminum in target 12 is preferentially sputtered over the silicon in target 12, leaving the surface of target 12 rich in silicon. At the onset of poisoned mode sputtering, the film deposited on substrate 16 is rich in silica and demonstrates a systematic and reproducible decrease in index of refraction. During continuous poisoned mode deposition, the silicon rich surface of target 12 can be sputtered away and the aluminum portion substantially returned to the bulk composition of target 12. Consequently, a metallic pre-condition step can be utilized to achieve a subsequent process for the deposition of a film having an increasing index of refraction under conditions of oxide/metal stoichiometry.

[0092] In step 402 of Figure 4, substrate 16 is prepared. Substrate 16 can be mounted on carrier sheet 17 and placed in apparatus 10. In step 403, gas flow parameters are adjusted for the particular deposition to be performed. The constituency and flow rates of the process gas are fixed. In some embodiments, the ratio of Ar and O<sub>2</sub>, for example, can be set and the flow rate of each gas set. Further, the combination of flow rate and vacuum system of apparatus 10 determines the pressure during deposition in apparatus 10.

[0093] In step 404, the substrate temperature is set. Substrate 16 may be brought to temperature over a period of time. In step 405, the scan characteristics of magnet 20 are fixed. In step 406, the power setting for power supply 18 is set. Finally, in step 407, the parameters of pulsed DC power supply 14 is set, including the power, frequency, and reverse pulsing time. In step 408, then, a film that depends on the parameters of reactor apparatus 10 is deposited on substrate 16. In some embodiments, films deposited by procedure 400 are thermally annealed after deposition.

[0094] Figure 4 illustrates an example deposition process only. Embodiments of deposition processes according to the present invention can be performed in various different orders.

[0095] Figure 9 shows a chart of various deposition parameters according to the present invention for various embodiments of target 12 and the indices of refraction, both before and after an anneal step, for the resulting deposited film on substrate 16. Each deposition was accomplished with an embodiment of apparatus 10 based on the AKT 1600 PVD reactor. Anneals were accomplished at 725° C for 30 min. Specific examples of particular depositions and characteristics of the resulting films deposited on substrate 16 are further discussed below.

[0096] Figure 10 shows the dependence of the index of refraction of silica layers deposited according to the present invention with process conditions. Figure 11 shows the dependence of index of refraction on the O<sub>2</sub>/Ar flow ratio for the deposition of pure alumina according to the present invention. Figure 12 shows the dependence of index for pure alumina films on the frequency of the pulsed DC power applied to target 12. Both parameters can be utilized to reliably control the index of refraction of films deposited on substrate 16 over a range of index values without the use of an additional cationic species, a so called 'dopant'. A third process parameter that can be utilized to adjust the index of refraction of a film deposited on substrate 16 is the bias power applied to substrate 16. Increasing the oxygen flow ratio, the frequency of the pulsed DC power applied to target 12 or the bias power applied to substrate 16 will systematically increase the index of refraction of the alumina film deposited on substrate 16. In the case of pure alumina films, minor to no change in the index occurs due to a subsequent anneal process.

[0097] Figure 13 shows the index of refraction of a film deposited on substrate 16 from an embodiment of target 12 with about 92 cat. % of Si and about 8 cat. % of Al for a series of sequential depositions in an embodiment of apparatus 10 based on the AKT 4300 PVD reactor, each following a metallic process condition. For constant high oxygen flow conditions, a small upward trend in the index of refraction is observed. As is generally true, the index of films deposited with higher substrate bias power is systematically lower than films deposited without substrate bias.

[0098] Figure 14 shows the upward trend of the index of refraction after metallic mode preconditioning of an embodiment of target 12 having composition of about 83 cat. % Si and about 17 cat. % Al for a series of depositions in an embodiment of apparatus 10 based on the AKT 1600 PVD reaction. As is shown in Figure 14, longer metallic preconditioning of target 12 results in the index of refraction of the films deposited on substrate 16 having a higher rate of

increase than for cases with less prolonged metallic preconditioning of target 12. The vertical lines on Figure 14 indicate places where target 12 was preconditioned with only Ar for the indicated periods of time. Figure 15 shows a decrease in the change in index for sequential films with this embodiment of target 12 deposited with reduced oxygen flow rates at a constant total pressure. A flow rate for oxygen was determined so that the run to run variation for the index of refraction of the film deposited on substrate 16 from this target was about .0001 (see the circled data points on the graph of Figure 15) which is similar to the variance of the index over the entire wafer of substrate 16, which is about 70 parts per million.

[0099] In some embodiments, films deposited by a pulsed DC biased method according to the present invention are uniformly amorphous throughout their thickness. As has been discussed above, biasing of substrate 16 leads to densification and uniformity in the deposited film. Figures 16A through 16D show a TEM photograph of a film 1601 deposited according to the present invention. Further, diffraction patterns shown in Figures 16B, 16C and 16D at points a, b and c, respectively, in deposited film 1601 show that the film is amorphous through the thickness of the film. The diffraction patterns of Figures 16B, 16C and 16D show no effects of crystallization. Further, the smoothness of the surface of film 1601 indicates a defect free film. The film deposited in Figure 16A is deposited with an 0.8/0.8 target (i.e., a target having the composition 52.0 cat. % of Si, 41.0 cat. % of Al, 0.8 cat. % of Er and 0.8 cat. % of Yb). The film is deposited at 6 kW of 120 kHz pulsed DC power with a reverse time of 2.3  $\mu$ s. The Argon and Oxygen flow rates are 60 sccm and 28 sccm, respectively. Substrate 16 is biased with 100 W of power.

[0100] Figure 17 shows the optical loss per centimeter, measured at 1310 nm, using a three prism coupling to the so called slab mode of the film on a 10 micron oxide, silicon wafer. As deposited the biased, pulsed DC film from a 60 cat. % Si and 40 cat. % Al film demonstrated about .1dB/cm loss. After an 800° C anneal in air, the loss was less than the measurement sensitivity of the prism coupling method. This data clearly demonstrates that films deposited according to embodiments of the present invention can be used for the purpose of constructing low loss planar light wave circuits.

[0101] Deposition of films according to the present invention can be utilized to deposit cladding layers, active core layers, and passive core layers of an optical amplifier structure or optical

waveguide structure. In some applications, for example multiplexer structures, the separation between adjacent waveguides can be small, for example about 8  $\mu\text{m}$ . In some embodiments, the deposition parameters of the upper cladding layer can be adjusted to not only adjust the index of refraction of the layer, but also to insure that the spacing between adjacent waveguides is small.

[0102] Figure 18 shows an example planarization deposition over a multiplexer structure. In the particular example of upper cladding layer 1803 shown in Figure 18, the deposition parameters from a 92 cat. % Si and 8 cat. % Al is: 5.5 Kw of Pulsed DC power applied at 200 KHz with 2.2  $\mu\text{s}$  of reverse time, gas flow of 75 sccm Ar and 100 sccm O<sub>2</sub>, a substrate bias of 650 W (at 2 MHz), and a substrate temperature of 200 °C. Layer 1803 was deposited with an AKT 4300 based embodiment of apparatus 10. As shown in Figure 18, the layer thickness in areas other than over waveguide structures 1801 and 1802 is 11.4  $\mu\text{m}$ . Waveguide structures 1801 and 1802 are 8.20  $\mu\text{m}$  high waveguides and separated by 6.09  $\mu\text{m}$  at the base and by 8.40  $\mu\text{m}$  at their top. In Figure 18, the undercladding layer 1804 is about 1.98  $\mu\text{m}$  thick.

[0103] Figure 19 illustrates deposition of material over a structure. Upper cladding layer 1803, in region 1901, will be angled from the horizontal by an angle  $\theta$ . The deposition and etching rates of a deposited layer depends on the angle  $\theta$ . Figures 20 and 21 illustrate different cases of deposition and etch rates as a function of the angle  $\theta$ . The relationship between the rate of deposition and the etch rates can be adjusted by adjusting the deposition parameters. For example, the bias power to substrate 16 can be adjusted to control the relationship between the etch rates and deposition rates of material.

[0104] Figure 22 illustrates deposition rates over a structure 2201 as a function of time. In Figure 2201, h is the thickness deposited over structure 2201. The planarization when layer 1803 becomes flat.

[0105] The time for planarization can be estimated as

$$t_p = \frac{\frac{W}{2} \tan \alpha + H}{a_{flat} - \frac{a_{min}}{\cos \alpha}},$$

where W is the width of structure 2201, H is the height of structure 2201,  $a_{flat}$  refers to the

accumulation rate on the flat surface,  $a_{\min}$  refers to the accumulation rate on the minimum accumulation slope, and  $\alpha$  is the surface angle from the horizontal plane of the minimum accumulation slope.

[0106] Figure 23 shows a deposited film 1803 as shown in Figure 18, except that the bias power to substrate 16 is set to 400 W instead of 650 W. As can be seen in Figure 23, a keyhole 2301 is formed with an incomplete filling of uppercladding layer 1803 between structures 1801 and 1802. Deposition of uppercladding layer 1803 substantially follows the trends illustrated in Figures 19 through 22.

[0107] Figure 24 shows deposition as shown in Figure 18, except that the bias power to substrate 16 is set to 600 W instead of 650 W. As can be seen in Figure 24, keyhole 2301 has closed leaving a small line defect 2401 in the fill.

[0108] Figure 28 shows deposition as shown in Figure 18, except that the bias power to substrate 16 is set to 900 W instead of 650 W. As can be seen in Figure 28, the etch rate has been increased to such an extent that the corners of structures 1801 and 1802 have been etched to form slopes 2501 and 2502, respectively.

[0109] Therefore, as illustrated in figures 18 through 25, an uppercladding layer can be deposited in accordance with the present invention such that it fills the space between adjacently placed waveguides. In general, the parameters can be optimized for index control and the bias power to substrate 16 can be adjusted for fill. In some embodiments, other parameters (e.g., the constituency of process gas, frequency and power of pulsed DC power source 14, and other parameters) in order to adjust the deposition and etch rates and thereby effectively planarize the structure as described.

[0110] Therefore, depositions of various films in embodiments of apparatus 10 according to the present invention with several embodiments of target 12 and the effects on index of refraction, uniformity of films, and fill characteristics of varying several of the process parameters has been discussed above. In some embodiments, stress effects due to wafer bowing of substrate 16 can also be reduced. Wafer bowing of substrate 16 can be reduced, reducing the stress in a film deposited on substrate 16, by, for example, depositing a film on the backside of substrate 16 before deposition of a film on substrate 16. In some embodiments, a film having a similar



thickness of a similar layer of material can be deposited on backside of substrate 16 prior to deposition of the film on substrate 16 according to the present invention. The wafer bowing resulting from differing thermal expansions of the film and substrate 16 is therefore countered by a similar stress from another film deposited on the backside of substrate 16.

[0111] Several specific examples film depositions utilizing apparatus 10 are discussed below. Further, examples of optical amplifiers produced utilizing the ceramic tiles according to the present invention are presented. These examples are provided for illustrative purposes only and are not intended to be limiting. Unless otherwise specified, apparatus 10 utilized in the following examples was based on the AKT 1600 reactor. Further, unless otherwise specified, the temperature of substrate 16 was held at about 200° C and the distance between substrate 16 and target 12 was 4 s/scan. The separation between substrate 16 and target 12 is about 6 cm.

#### EXAMPLE 1

[0112] An AKT 1600 based reactor can be utilized to deposit a film. In this example, a wide area metallic target of dimension 550X 650 mm with composition (Si/Al/Er/Yb) being about 57.0 cat. % Si, 41.4 cat. % Al, 0.8 cat. % Er, and 0.8 cat. % Yb (a “.8/.8” target) was fabricated as described in the ‘247 patent.

[0113] In step 402, a 150 mm P-type silicon wafer substrate was placed in the center of a 400x500 mm glass carrier sheet 17. Power supply 14 was set to supply 6000 watts of pulse DC power at a frequency of 120KHz with a reverse pulsing time of about 2.3us. Magnet 20, which is a race-track shaped magnet of approximate dimension 150mmx600mm, was swept over the backside of the target at a rate of about 4 seconds per one-way scan. The temperature of substrate 16 was held at 200C and 100W of 2 MHz RF power was applied to substrate 16. The target 12 to substrate 16 distance was about 6.5 cm. The sputtering gas was a mixture of Argon and Oxygen. Substrate 16 and carrier 17 was preheated to 350° C for at least 30min prior to deposition. The active film was deposited in the poison mode. Deposition efficiency was approximately 1um/hr.

[0114] Figure 5 shows the hysteresis curve of this particular embodiment of target 12. When target 12 under goes the transition from metallic to poison mode, the target voltage drops from

an average of about 420V to an average of about 260V. Before each film deposition, in step 401, target 12 is cleaned by pure Argon sputtering in the metallic mode. Then target is then conditioned in poison mode with the oxygen flow much higher than the flow required at the transition region.

[0115] Tables 1A through 1C shows some effects on the deposited films of depositions with the 0.8/0.8 target under different operating conditions. Table 1A includes photoluminescence (pumped at 532 nm) and index of refraction for films deposited on substrate 16 with different Ar/O<sub>2</sub> gas flow ratios with no bias power applied to substrate 16.

Table 1A

Target Power (KW)	Ar/O2	Frequency (KHz)	Reverse Pulsing Time (us)	Bias (W)	PL/um (532nm)	Index
6	30/42	200	2.3	0	1973	1.5142
6	30/36	200	2.3	0	2358	1.5215
6	60/30	200	2.3	0	3157	1.5229
6	60/28	200	2.3	0	3421	1.5229

[0116] Table 1B shows the variation in photoluminescence (pumped at 532 nm) and index of refraction of the film deposited on substrate 16 with deposition processes having with the same Ar/O<sub>2</sub> ratios but different pulsed DC power frequencies from power supply 14.

Table 1B

Target Power (KW)	Ar/O2	Frequency (KHz)	Reverse Pulsing Time (us)	Bias (W)	PL/um (532nm)	Index
3	60/28	100	2.3	100	1472	1.5146
4	60/28	75	3.5	100	2340	1.5189
6	60/28	120	2.3	100	5178	1.5220

[0117] Table 1C shows the photoluminescence and index as deposited where the bias power to substrate 16 is varied.

Table 1C

Target Power (KW)	Ar/O2	Frequency (KHz)	Reverse Pulsing Time (us)	Bias (W)	PL/um (532nm)	Index
6	60/28	200	2.3	0	3657	1.5230
6	60/28	200	2.3	100	2187	1.5244
6	60/28	200	2.3	200	3952	1.5229
6	60/28	200	2.3	300	5000	1.5280

[0118] The photoluminescence values can be measured with a Phillips PL-100. The deposited film can be pumped with a 532 nm laser and the luminescence at 980 is measured. The index is the index of refraction. Typically, films deposited are annealed in order to activate the erbium. Figure 6 shows the photoluminescence and lifetime versus anneal temperature for a typical film deposited as described in this example.

EXAMPLE 2

[0119] A waveguide amplifier can be deposited according to the present invention. An embodiment of target 12 having composition 57.4 cat. % Si, 41.0 cat. % Al, 0.8 cat. % Er 0.8 cat. % Yb (the “.8/.8 target”) can be formed as disclosed in the ‘245 application. The Er-Yb (0.8/0.8) co-doped Alumino-Silicate film was deposited onto a 6 inch wafer of substrate 16 which includes a 10 μm thick thermal oxide substrate, which can be purchased from companies such as Silicon Quest International, Santa Clara, CA. Target 12 was first cleaned by sputtering with Ar (80 sccm) only in the metallic mode. Target 12 was then conditioned in poison mode by flowing 60 sccm of Argon and 40 sccm of oxygen respectively. The power supplied to target 12 during conditioning was kept at about 6 kW.

[0120] An active core film was then deposited on substrate 16. The thickness of the deposited film is approximately 1.2 μm. The deposition parameters are shown in Table 2.

Table 2.

Target Power (KW)	Ar/O2 (sccm)	Pulsing Frequency (KHz)	Bias (W)	Reverse pulsing time (us)
6	60/28	120	100	2.3

[0121] A straight waveguide pattern can then formed by standard photolithography techniques. The active core was etched using reactive ion etch followed by striping and cleaning. Next, a 10  $\mu\text{m}$  top cladding layer is deposited using a similar deposition process according to the present invention. An embodiment of target 12 with composition 92 cat. % Si and 8 cat. % Al as shown in Figure 9 to form the top cladding layer. The index difference between the top cladding layer and the active layer is about 3.7%. The amplifier is then annealed at 725° C for about 30 min (see Figure 6, for example).

[0122] The erbium excited-state lifetime and the up-conversion coefficient were measured to be 3ms and  $4.5 \times 10^{-18} \text{ cm}^3/\text{s}$ , respectively. A net gain of about 4dB for small signal (about -20 dBm) with fiber to waveguide and to fiber coupling was obtained. Waveguide length was 10cm and the width was about 1.5 to 8  $\mu\text{m}$ . The coupling loss between the fiber and the waveguide is 3-4 dB/facet, and passive excess loss is 0.1-0.2 dB/cm for 3um waveguide. The waveguide was both co- and counter pumped with 150 mW 980nm laser per facet.

### EXAMPLE 3

[0123] This example describes production of a dual core Erbium/Yttrium co-doped amplifier according to the present invention. In one example, substrate 16 is a silicon substrate with an undercladding layer of thermally oxidized  $\text{SiO}_2$  of about 15  $\mu\text{m}$  thick. Substrate 16 with the thermal oxide layer can be purchased from companies such as Silicon Quest International, Santa Clara, CA. A layer of active core material is then deposited on substrate 16 with a Shadow Mask as described in the '138 application. Use of a shadow mask results in a vertical taper on each side of a finished waveguide which greatly enhances the coupling of light into and out of the waveguide.

2025 RELEASE UNDER E.O. 14176

[0124] Active core layer is deposited from a 0.8/0.8 target as described in the '247 application having composition 57.4 cat. % Si, 41.0 cat. % Al, 0.8 cat. % Er, and 0.8 cat. % Yb. The deposition parameters are identical to that of Example 2 described above. The active layer is deposited to a thickness of about 1.2  $\mu\text{m}$ .

[0125] A passive layer of aluminasilicate is then deposited over the active layer. A passive layer of about 4.25  $\mu\text{m}$  thickness can be deposited with an embodiment of target 12 having composition of Si/Al of about 87 cat. % Si and about 13 cat. % Al. The passive layer and active layer are then patterned by standard lithography techniques to form a core that has a width of about 5.0  $\mu\text{m}$  for the active core and tapering to about 3.5  $\mu\text{m}$  at the top of the passive core with an effective length of about 9.3 cm.

[0126] Upper cladding layer is then deposited from a Si/Al target of 92 cat. % Si and 8 cat. % Al. Deposition of the upper cladding layer is shown in Figure 9. In some embodiments, the upper cladding layer can be deposited with a non-biased process. The thickness of the upper cladding layer can be about 10  $\mu\text{m}$ . The amplifier formed by this process is then annealed at 725° C for about 30 min.

[0127] The as-deposited Erbium and Ytterbium concentrations in the active layer of core 303 is  $2.3 \times 10^{20} \text{ cm}^{-3}$  Erbium concentration and  $2.3 \times 10^{20} \text{ cm}^{-3}$  Ytterbium concentration. The index of the core is 1.508 and the index of cladding layers are 1.4458 for undercladding layer 302 and 1.452 for uppercladding layer 304. The parameter  $\Delta n/n$  is therefore about 5.0%.

[0128] A reverse taper mode size converter, *see* the '138 application, is utilized for coupling light into waveguide amplifier 300. The insertion loss at 1310 nm is about 2 dB. Figure 26 shows the amplifier performance of this example. In Figure 26, amplifier 300 is pumped with 150 mW from one side pumping with 984 nm light. Gain flattening is achieved within about 1 dB in the range 1528 nm to 1562 nm for small input signals (-20 dBm). For large input signals (0 dBm), gain flattening is also achieved within about 1 dB.

#### EXAMPLE 4

[0129] Another example of production of a waveguide amplifier is described here. Again, substrate 16 can be a Si wafer with about a 15  $\mu\text{m}$  thick thermal oxide as can be purchased from Silicon Quest International, Santa Clara, CA. The embodiment of target 12 for the deposition of the active core can have a composition of about 50 cat. % Si, 48.5 cat. % Al, 1.5 cat. % Er (the "1.5/0" target), which can be fabricated as discussed in the '138 application. Target 12 was first cleaned by sputtering with Ar (80 sccm) only in the metallic mode. Target 12 was then conditioned in poison mode by flowing 60 sccm of Argon and 40 sccm of oxygen respectively.

[0130] The pulsed DC power supplied to target 12 was about 6 kW. Whenever a brand new target was used or when the target has been expose to atmosphere, a long time of condition (for example more than 30hrs of conditioning) may be necessary to ensure films with the best active core property (longest life time and highest photoluminescence) are deposited. Substrate 16 is then preheat at about 350° C for about 30min before deposition.

[0131] The active core film was deposited onto a 6 inch thermal oxide wafer, which has been previously discussed, from the 1.5/0 target. The thermal oxide thickness was about 10  $\mu\text{m}$  as described in previous examples. The active core is deposited to a thickness of about 1.2  $\mu\text{m}$  with a deposition time of approximately 1 hr. The process condition are as listed in Table 4 below.

Table 3

Target Power (KW)	Ar/O2 (sccm)	Pulsing Frequency (KHz)	Bias (W)	Reverse pulsing time (us)
6	60/28	120	100	2.3

[0132] A straight waveguide pattern can then be formed by a standard photolithography procedure. The active core was etched using reactive ion etch followed by striping and cleaning. Finally, a 10  $\mu\text{m}$  top cladding layer is deposited using a similar process. A target having composition 92 cat. % Si and 8 cat. % Al with deposition parameters as described in Figure 9 was used to deposit the top cladding. The difference between the index of refraction between the core and the cladding is then about 3.7%.

[0133] In this example, annealing of the amplifier structure was performed at various anneal temperatures. The results of the various anneals are shown graphically in Figures 27 and 28. Figure 27 shows both internal gain in the C-band and insertion loss at 1310 nm of a 2.5 $\mu$ m wide, 10.1 cm long waveguide as deposited in this example as a function of annealing temperature. The life time in ms and up-conversion constants in cm<sup>-3</sup>/s measurements for the deposited active core film at different annealing temperature are shown in Figure 28.

#### EXAMPLE 5

[0134] One of the problems encountered during the reactive sputtering from an alloy metallic target is that the film composition drifts from run to run due to the difference in sputtering yields from the elements that forms the target alloy. For example, with Ar as a sputtering gas, the sputtering yield of Aluminum is about 3-4 times that of Silicon, while sputtering yield of Alumina is only about 50% that of Silica. Therefore, during the metal burn in, more Aluminum is sputtered from the target, resulting in a Si rich target surface. When sputtering in the poison mode, more Silica will be removed from target. Thus, as deposition goes on, the composition of the film deposited on substrate 16 will drift from lower Alumina concentration to higher Alumina concentration. This results in the index of refraction of a film drifting up with subsequent depositions from a target 12, as is shown for the deposition described in Example 4 in Figure 29. Figure 30 shows the drift in photoluminescence pumped at 532 nm with subsequent depositions. Figure 31 shows drift in the excited state lifetime with subsequent depositions from a target. The embodiment of target 12 utilized in Figures 29 through 31 is the 1.5/0 target and the deposition parameters are as described above in Example 4.

[0135] The drift can be stabilized by recondition target 12 prior to deposition. The recondition process (or burn in) consists of both sputtering in metallic mode and then sputtering in poison mode to condition target 12. The burn in time in metallic mode needs to be as short as possible and at the same time insure no arcing during the poison mode deposition. Figure 32 shows the

much improved drift in the index of refraction and the photoluminescence when target 12 is reconditioned between subsequent depositions.

EXAMPLE 6

[0136] This example describes the fabrication of another Er-Yb codoped waveguide amplifier according to the present invention. The active core is deposited with an embodiment of target 12 with composition about **49 cat. % Si, 48 cat. % Al, 1.6 cat. % Er and 0.5 cat. % Yb**, which can be fabricated as described in the '247 application. Target 12 was first cleaned by sputtering with Ar (80 sccm) only in the metallic mode. Target 12 was then conditioned in poison mode by flowing 60 sccm of Argon and 40 sccm of oxygen respectively. The pulsed DC power supplied to target 12 was kept at 5 kW. Table 4 shows photoluminescence and index of refraction of as-deposited films from this example at some typical process conditions. The units for photoluminescence are the number of counts per micron. Lifetime and photoluminescence measured after annealing at various different temperatures are shown in Table 5.

Target 4

Target Power (KW)	Ar/O2 (sccm)	Pulsing Frequency (KHz)	Bias (W)	Reverse pulsing time (us)	532 nm PL/um	Index
5	60/34	120	100	2.3	3367	1.5333
5	60/30	120	100	2.3	3719	1.5334

Table 5

Anneal Temperature °C	Life Time (ms)	PL (532nm)/um
725	3	7000
775	3	7000
800	4	7500
825	4.7	8560
850	5.8	10000
900	6.9	17000

[0137] A waveguide amplifier was fabricated using this material in the similar fashion as described in examples 2-4. The active core was first deposited on substrate 16, which includes a



10 $\mu$ m thermal oxide layer, using the following deposition parameters: target power 5KW, pulsing frequency 120KHz, bias 100W, reverse time 2.3 $\mu$ s, Argon and Oxygen flow are 60 sccm and 30sccm respectively. The active core thickness is deposited to a thickness about 1.2 $\mu$ m, which takes approximately 1 hr. All wafers are preheated at about 350° C for 30min before deposition. A straight waveguide pattern is then formed by standard photolithography procedure. The active core was etched using reactive ion etch following by striping and cleaning. Next, a 10 $\mu$ m top cladding layer is deposited using similar process. The "92/8" (92 cat. % Si and 8 cat. % Al) metallic target was used to deposit top clad according to deposition parameters shown in Figure 9, resulting in a 4 % index difference between active core and cladding. The wave guide was then annealed at 800° C for about 30 min.

[0138] This waveguide was tested for gain using the method described in previous examples. However no net gain was observed from this waveguide since the passive loss was too high.

#### EXAMPLE 7

[0139] In addition to active material layers (i.e., layers having rare-earth ion concentrations), passive layers can also be deposited. Figure 9 shows deposition parameters for several target compositions, including some targets for deposition of passive (i.e., alloys of Al and Si with no rare earth ion concentration) layers. In this example, an embodiment of target 12 with a material composition of pure silicon is utilized.

[0140] Apparatus 10 can be based on an AKT 1600 reactor and deposited with about 1 to 3 kW of pulsed DC target power supplied to target 12. Particular depositions have been accomplished at 2.5 kW and 1.5 kW. The frequency of the pulsed DC power is between about 100 and 200 Khz. Some depositions were performed at 200 kHz while others were performed at 100 kHz. The reverse time was varied between about 2  $\mu$ s and about 4  $\mu$ s with particular depositions performed at 2.3  $\mu$ s and 3.5  $\mu$ s. The bias power to substrate 16 was set to zero.

[0141] Index variation of SiO<sub>2</sub> films with bias to substrate 16 and deposition rates as a function of bias power to substrate 16 is shown in Figure 10.

[0142] The process gas included a mixture of Ar, N<sub>2</sub> and O<sub>2</sub>. The Ar flow rates was set at 20 sccm while the O<sub>2</sub> flow rate was varied between about 5 and about 20 sccm and the N<sub>2</sub> flow rate was varied from about 2 to about 35 sccm. Figure 33 shows the variation in the index of refraction of a film deposition on substrate 16 as the O<sub>2</sub>/N<sub>2</sub> ratio is varied.

#### EXAMPLE 8

[0143] Alternatively, films can be deposited on substrate 16 from a pure alumina target. In an example deposition with an embodiment of target 12 of alumina in an embodiment of apparatus 10 based on the AKT 1600 reactor, the pulsed DC target power was set at 3 kW and the frequency was varied between about 60 kHz and 200 kHz. The reverse time was set at 2.5 μs. Again, no bias power was supplied to substrate 16. The O<sub>2</sub> flow rate was varied from about 20 to about 35 sccm, with particular depositions performed at 22 and 35 sccm. The Ar flow rate was set at 26 sccm. A post deposition anneal of substrate 16 at 800° C for 30 min. was performed.

[0144] Figure 12 shows the variation of refractive index of the film deposited on substrate 16 with varying frequency of the pulsed DC power supplied to target 12. Figure 11 shows the variation in refractive index of a film deposited on substrate 16 with varying O<sub>2</sub>/Ar ratio. As can be seen from Figures 33, 34 and 35, the index of refraction of films deposited from alumina can be adjusted by adjusting the process gas constituents or by adjusting the frequency of the pulsed DC power supplied to target 12 during deposition.

#### EXAMPLE 9

[0145] Additionally, passive films can be deposited from targets having a composition of Si and Al. For example, layers have been deposited from embodiments of target 12 with composition 83 % Si and 17 % Al. About 4.5 kW of pulsed DC power at about 200 kHz frequency was supplied to target 12. The reverse time was about 2.2 μs. A bias power of about 150 W was

supplied to substrate 16 during deposition. Figures 14 and 15 show variation of the index of refraction for subsequent runs from this target.

**[0146]** The examples and embodiments discussed above are exemplary only and are not intended to be limiting. One skilled in the art can vary the processes specifically described here in various ways. Further, the theories and discussions of mechanisms presented above are for discussion only. The invention disclosed herein is not intended to be bound by any particular theory set forth by the inventors to explain the results obtained. As such, the invention is limited only by the following claims.

## Claims

We claim:

1. A method of depositing a film on a substrate, comprising:
  - providing pulsed DC power through a filter to a target;
  - providing bias power to a substrate positioned opposite the target;
  - providing process gas between the target and the substrate,wherein the filter protects a pulsed DC power supply from the bias power.
2. The method of Claim 1, further including holding the temperature of the substrate substantially constant.
3. The method of Claim 1, wherein providing pulsed DC power through the filter includes supplying up to about 10 kW of power at a frequency of between about 40 kHz and about 350 kHz and a reverse time pulse between about 1.3 and 5  $\mu$ s.
4. The method of Claim 1, wherein providing bias power to the substrate includes supplying up to 1000 W of RF power to the substrate.
5. The method of Claim 4, wherein the filter is a band reject filter at the frequency of the bias power.
6. The method of claim 4, wherein the bias power is zero.
7. The method of Claim 1, wherein the film is an upper cladding layer of a waveguide structure and the bias power is optimized to provide planarization.
8. The method of Claim 1, wherein the process gas includes a mixture of Oxygen and Argon.
9. The method of Claim 9, wherein the Oxygen flow is adjusted to adjust the index of refraction of the film.
10. The method of Claim 8, wherein the process gas further includes nitrogen.

11. The method of Claim 1, wherein providing pulsed DC power to a target includes providing pulsed DC power to a target which has an area larger than that of the substrate.
12. The method of Claim 1, further including uniformly sweeping the target with a magnetic field.
13. The method of Claim 12, wherein uniformly sweeping the target with a magnetic field includes sweeping a magnet in one direction across the target where the magnet extends beyond the target in the opposite direction.
14. The method of Claim 1, further including depositing a film on the backside of target 12.
15. A reactor according to the present invention, comprising:
  - a target area for receiving a target;
  - a substrate area opposite the target area for receiving a substrate;
  - a pulsed DC power supply; and
  - a bias power supply coupled to the substrate.
16. The reactor of Claim 15, wherein the target has a surface area greater than the surface area of the substrate.
17. The reactor of Claim 15, further including a scanning magnet which provides uniform erosion of the target.
18. The reactor of Claim 17, wherein the scanning magnet scans across the target in a first direction and extends in a second direction perpendicular to the first direction.
19. The reactor of Claim 18, wherein the magnet extends beyond the target in the second direction.
20. A method of depositing a film on a substrate, comprising:
  - conditioning a target;
  - preparing the substrate;

adjusting the bias power to the substrate;

setting the process gas flow; and

applying pulsed DC power to the target to deposit the film.

21. The method of Claim 20, wherein conditioning the target includes sputtering with the target in a metallic mode to remove the surface of the target and sputtering with the target in poisonous mode to prepare the surface.
22. The method of Claim 21, wherein setting the process gas flow includes adjusting constituents in order to adjust the index of refraction of the film.
23. The method of Claim 21, wherein applying pulsed DC power includes setting the frequency in order to adjust the index of refraction of the film.
24. The method of Claim 21, further including adjusting a temperature of the substrate in order to adjust the index of refraction of the film.
25. A method of forming a waveguide amplifier, comprising:
- providing a substrate with an undercladding layer;
  - providing a target having a concentration of rare-earth ions opposite the substrate;
  - supplying process gas between the target and the substrate;
  - applying pulsed DC power through a filter to the target to deposit a film;
  - patterning the film to form a core;
  - depositing an uppercladding layer over the core.
26. The method of Claim 25, wherein providing a substrate includes providing a silicon substrate with a thermal oxide layer.
27. The method of Claim 25, wherein providing a target includes providing a target having a concentration of up to about 5 cat. % of rare earth ions.

28. The method of Claim 27, wherein providing a target includes providing a target of Al and Si.
29. The method of claim 25, wherein providing a target includes providing a target with a concentration of Al.
30. The method of Claim 29, wherein providing a target includes providing a target with a concentration of Si.
31. The method of Claim 29, wherein providing a target includes providing a target with a concentration of rare earth ions.
32. The method of Claim 25, further including providing bias power to the substrate.
33. The method of Claim 25, further including scanning a magnet over the target.
34. The method of Claim 25, wherein scanning the magnet over the target includes moving the magnet in a first direction.
35. The method of Claim 34, wherein the magnet extends beyond the target in a second direction perpendicular to the first direction.
36. The method of Claim 25, wherein the target has a surface area greater than the surface area of the substrate.
37. The method of Claim 32, wherein the filter rejects power at a frequency of the bias power.
38. A sputtering apparatus, comprising:
- means for providing pulsed DC power to a target; and
  - means for providing bias power to a substrate.
39. The apparatus of Claim 38, further including
- means for providing process gas between the target and the substrate.

## Biased Pulse DC Reactive Sputtering of Oxide Films

Hongmei Zhang  
Mukundan Narasimhan  
Ravi Mullapudi  
Richard E. Demaray

### Abstract

A biased pulse DC reactor for sputtering of oxide films is presented. The biased pulse DC reactor couples pulsed DC at a particular frequency to the target through a filter which filters out the effects of a bias power applied to the substrate, protecting the pulsed DC power supply. Films deposited utilizing the reactor have controllable material properties such as the index of refraction. Optical components such as waveguide amplifiers and multiplexers can be fabricated using processes performed on a reactor according to the present invention.



M-12 245 US  
1/27

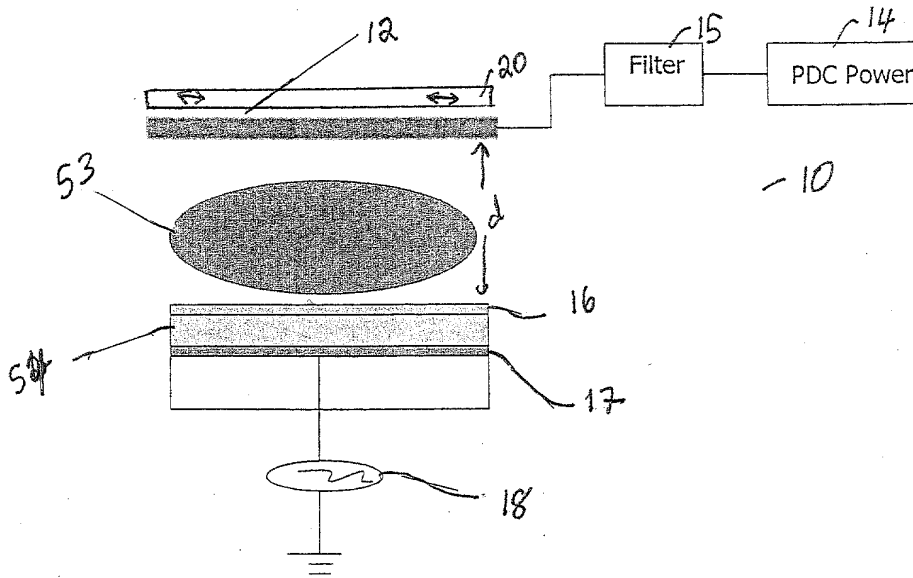


Figure 1A

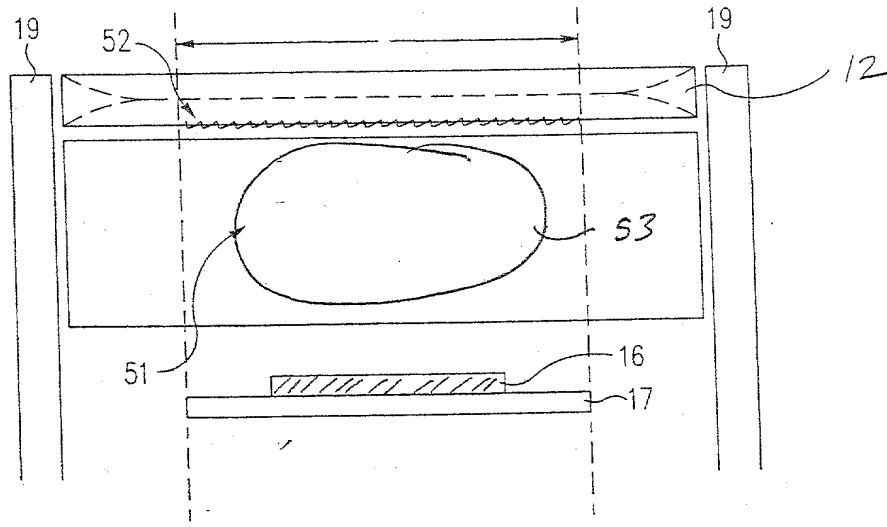


FIG. 1B

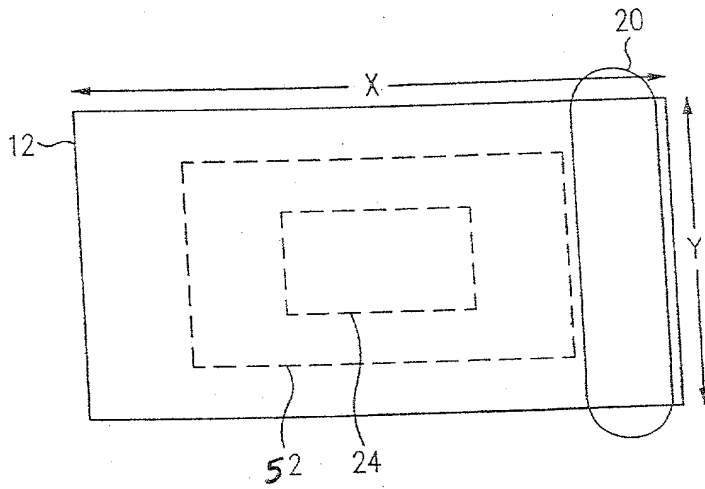


FIG. 2

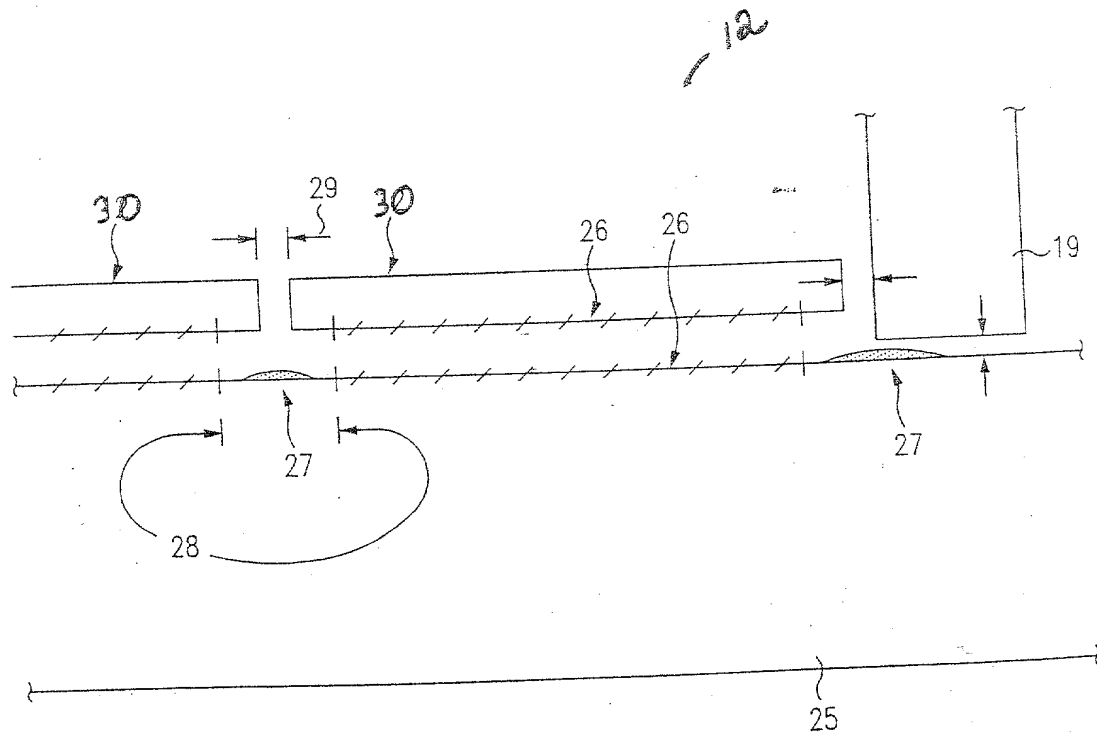


FIG. 3

m- 12245 US  
3/27

400

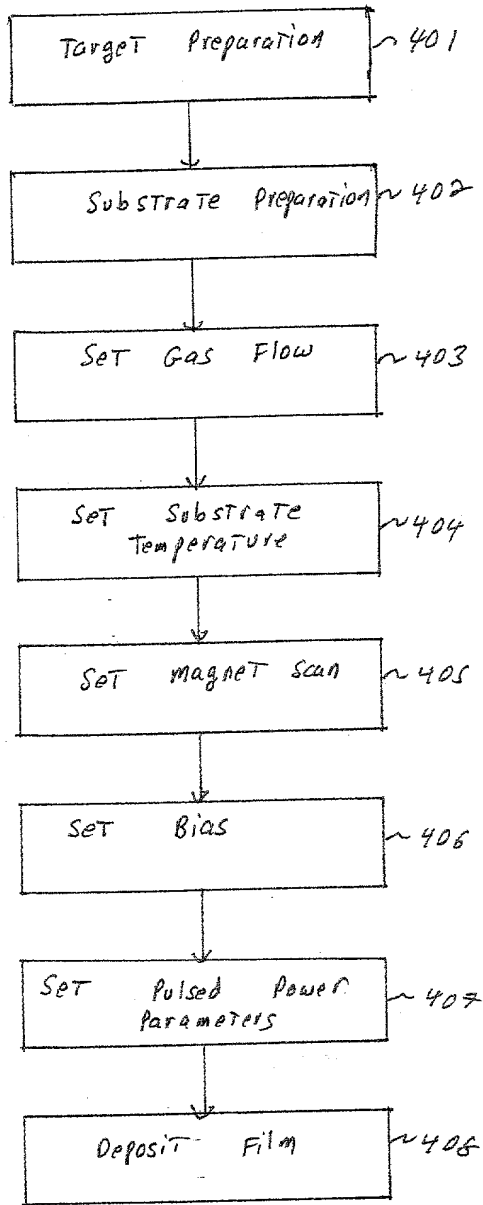


Figure 4

202510-091502

M-12245 US  
4/27

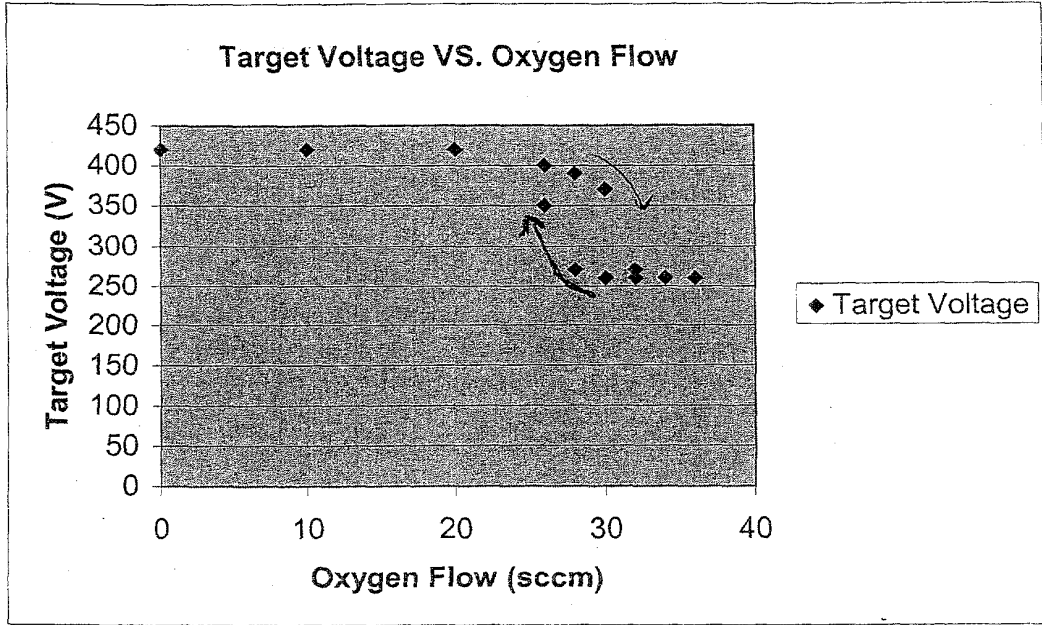


Figure 5

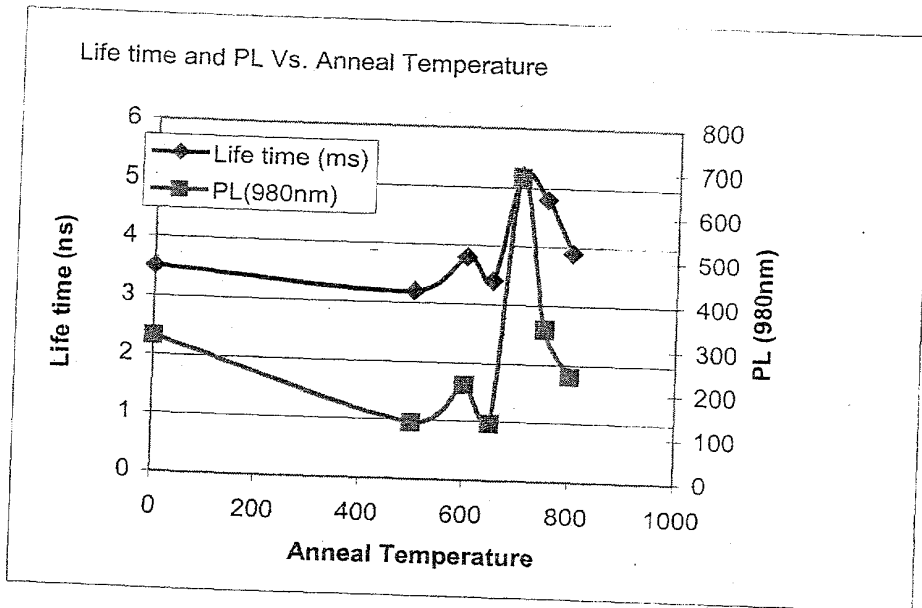
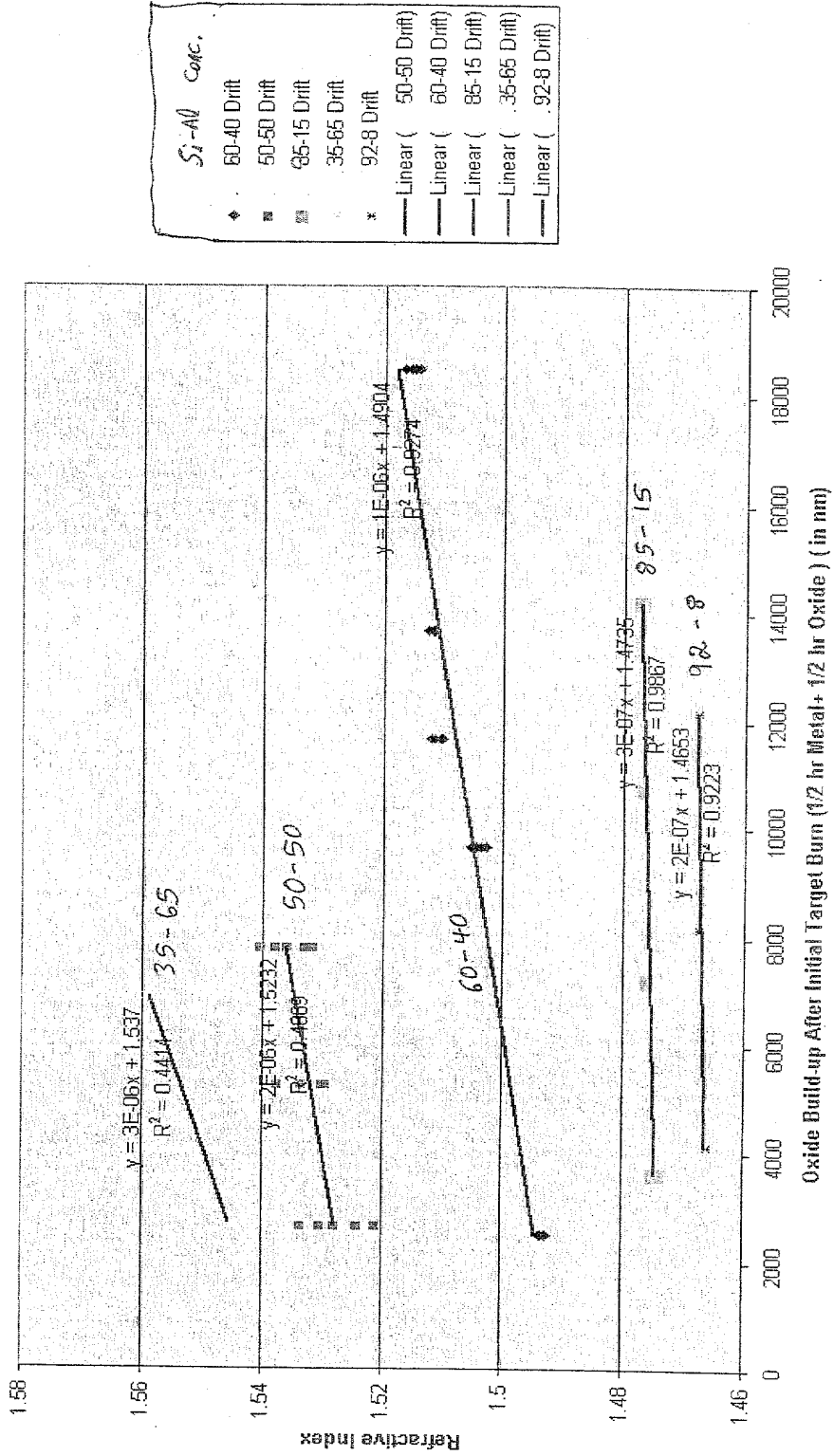


Figure 6

2025 RELEASE UNDER E.O. 14176

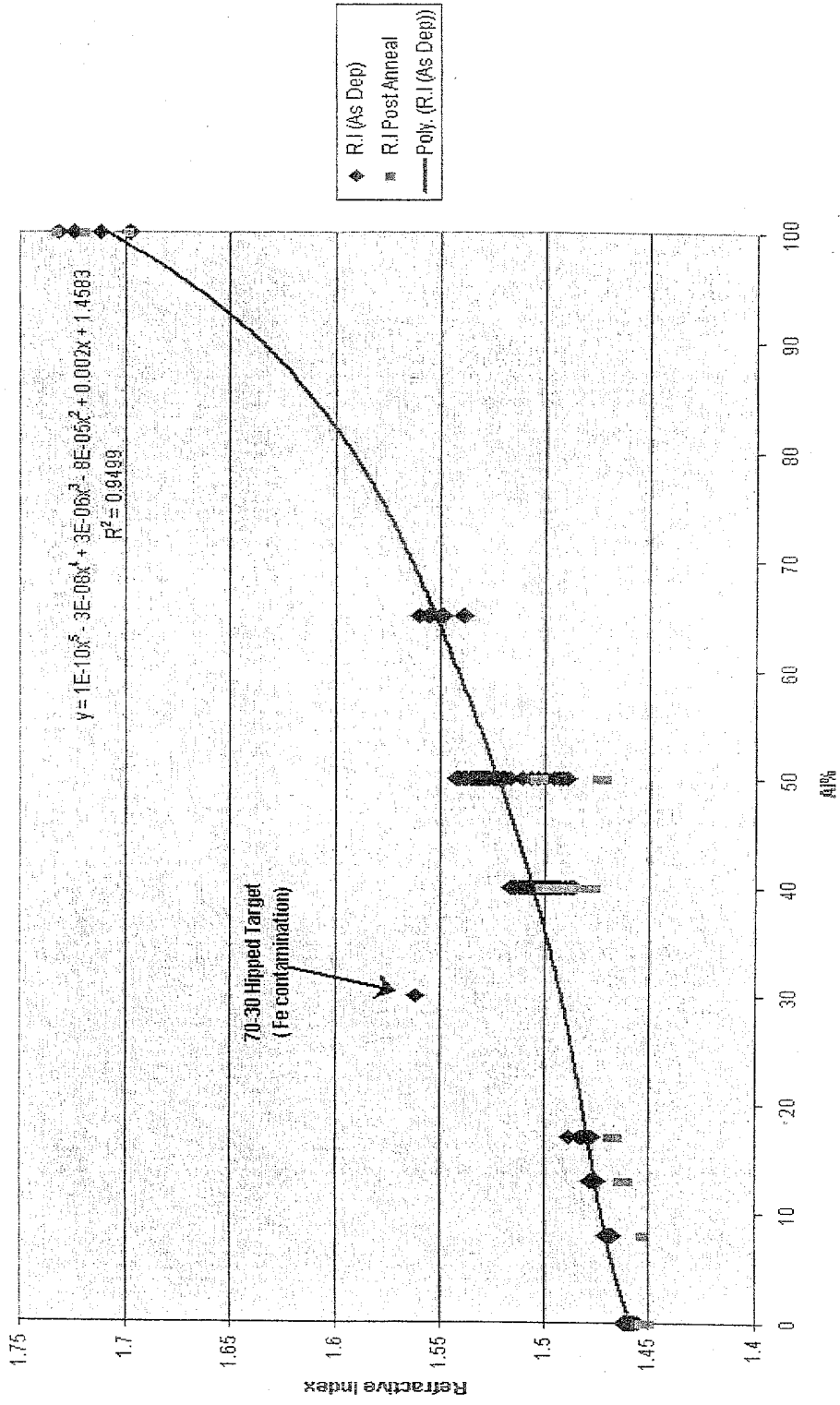
Alumino Silicates Index Drift in Burn-in Cycle (As Deposited from Al/Si Cast Metal Targets)



m-18245 US  
5/87

Figure 7

Refractive Index as a function of Al% in Aluminosilicates



6/97  
SN 1845 US - M

Figure 8

Material (Er/Yb/Al/Si)	Expected index (Post anneal)	Actual index (Post anneal)	Process Conditions (Annealed 725c 30min)
0.8/0.8/41.4/57	1.506	1.510	6KW, Ar-60, O2-28sccm, 120KHz, 2.2us, 60mm T-W Space, 4-5mm T-M Space, 0-400W Bias
1.6/0.5/49/48.9	1.526	1.528	6KW, Ar-60, O2-28sccm, 120KHz, 2.2us, 60mm T-W Space, 4-5mm T-M Space, 0-400W Bias
0/0/8/92	1.452	1.456- 1.459	4.5KW, Ar-30-60, O2-28-44, 120-200KHz, 2.2us, 60-85mm T-W Space, 4-5mm T-M Space, 0-400W Bias
0/0/40/60	1.504	1.486- 1.501	3.0-4.5KW, Ar-30, O2-44, 75-200KHz, 2.2-3.0us, 60-85mm T-W Space, 4-5mm T-M Space, 0-400W Bias
0/0/50/50	1.520	1.491- 1.503	4.0-4.5KW, Ar-30, O2-44, 75-200KHz, 2.2-3.0us, 60-85mm T-W Space, 4-5mm T-M Space, 0-400W Bias
0/0/65/35	1.544	1.545- 1.560	4.5-5.5KW, Ar75-90, O285-100, 200KHz, 2.2us, 85mm T-W Space, 4-5mm T-M Space, 0-400W Bias
0/0/30/70	1.490	1.562 (high Fe content)	5.0KW, Ar75, O2-100, 200KHz, 2.2us, 85mm T-W Space, 4-5mm T-M Space, 0-400W Bias
1.5/0/48.5/50	1.523	1.509- 1.513	6KW, Ar-60, O2-28sccm, 120KHz, 2.2us, 60mm T-W Space, 4-5mm T-M Space, 0-400W Bias

Figure 9

7/27  
m - 12845 us

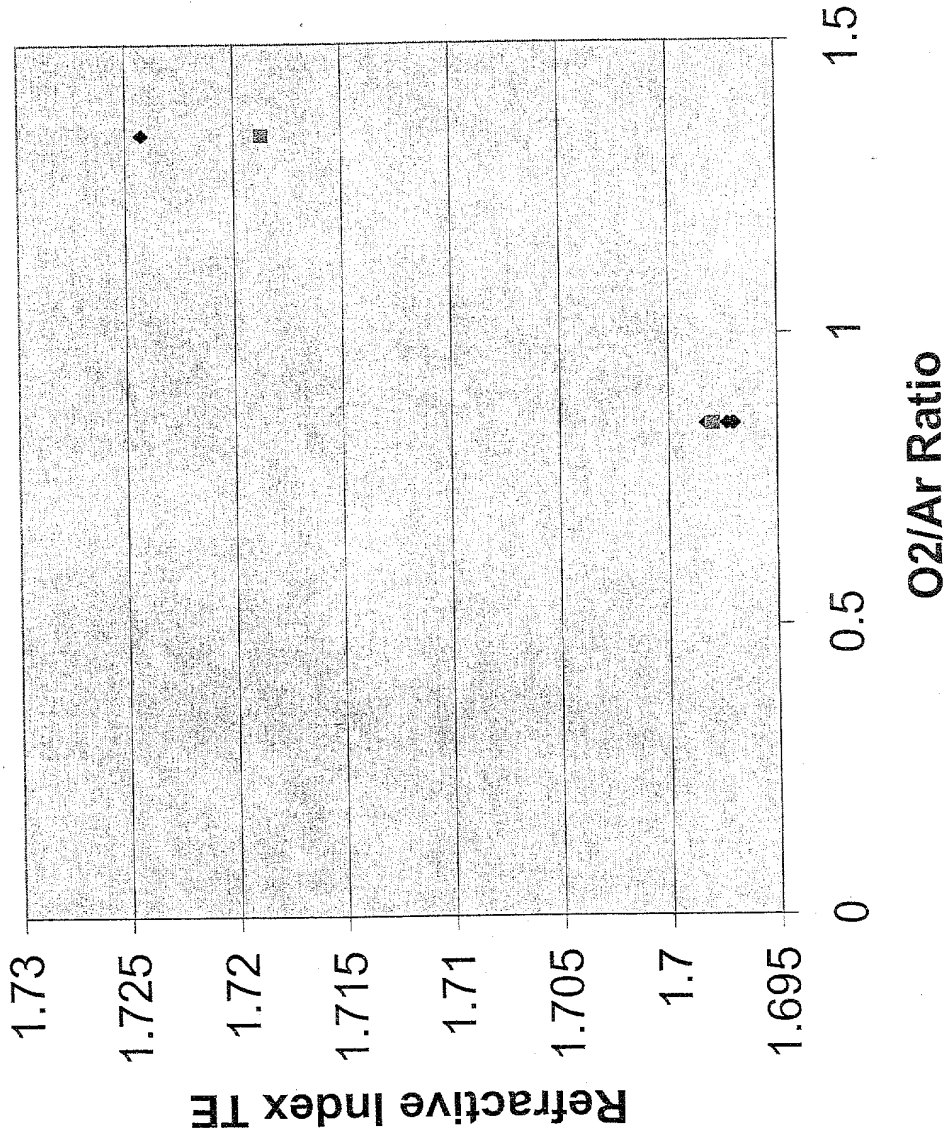
Bias Power (Watts)	DC Power (KW)	Pulsing Freq (KHz)	Reverse Time (μs)	Ar Flow (sccms)	O2 Flow (sccms)	Wafer Position	Target To Wafer Spacing (mm)	Refractive Index Avg (@1550nm)	Refractive Index STD (@1550nm)	Dep Rate (um/Hr)
150	4.5	200	2.2	100	100	1	55	1.461508	0.000535	0.957654
150	4.5	200	2.2	100	100	2	55	1.462329	0.000376	0.962581
400	4.5	200	2.2	100	100	1	55	1.462774	0.000103	0.814007
400	4.5	200	2.2	100	100	2	55	1.463583	0.000095	0.824566

Figure 10

50 500 01 - u  
8/27



### R.I. vs O2/Ar Ratio



m-12845 us 9/27

Figure II

### R.I. vs Pulsing Frequency for Alumina

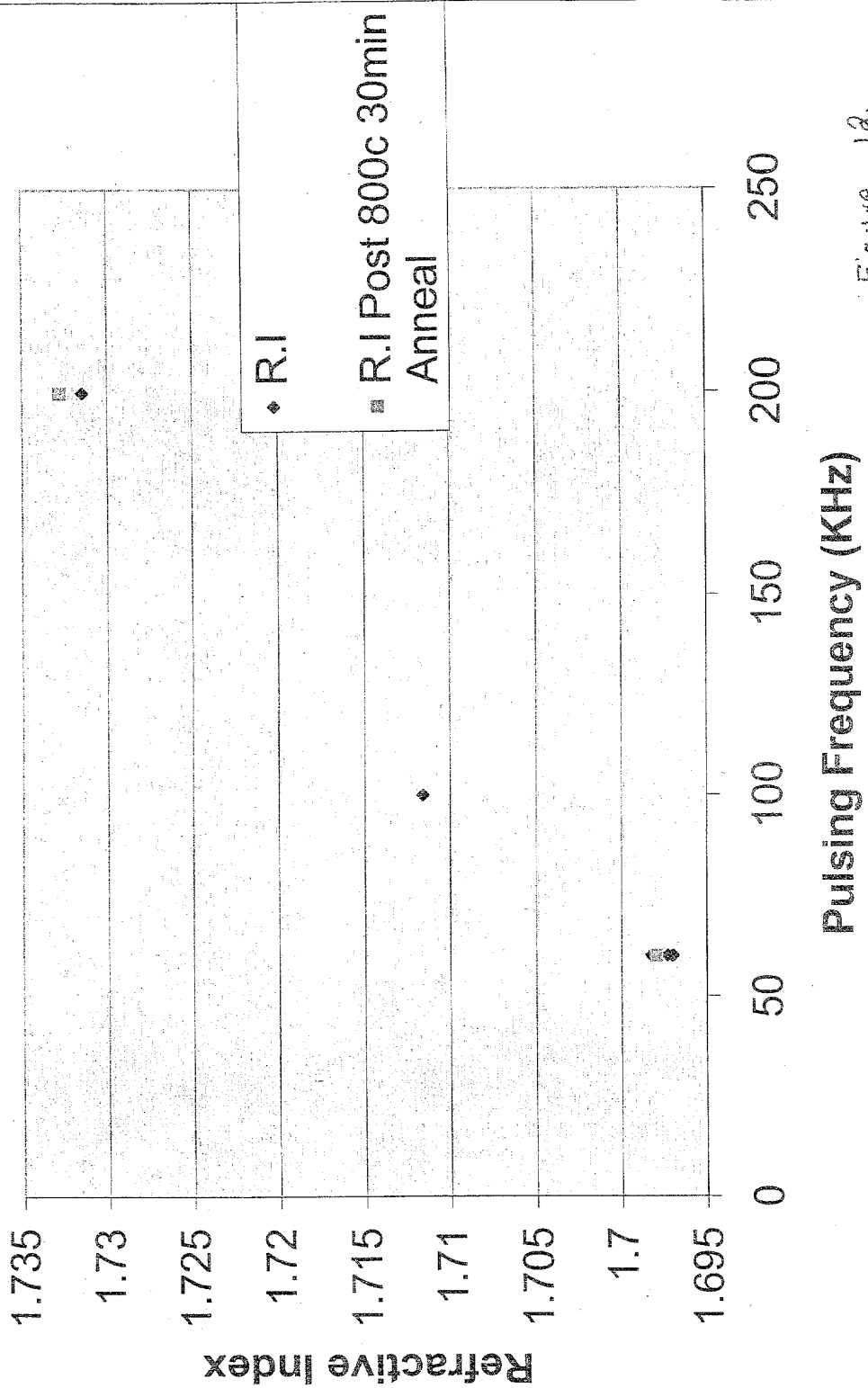


Figure 1a

M-12 245 US  
10/27

Target 9A-8  
AET 4300 Based Reactor

### Index and Dep Rate Drifts Pre & Post Anneal

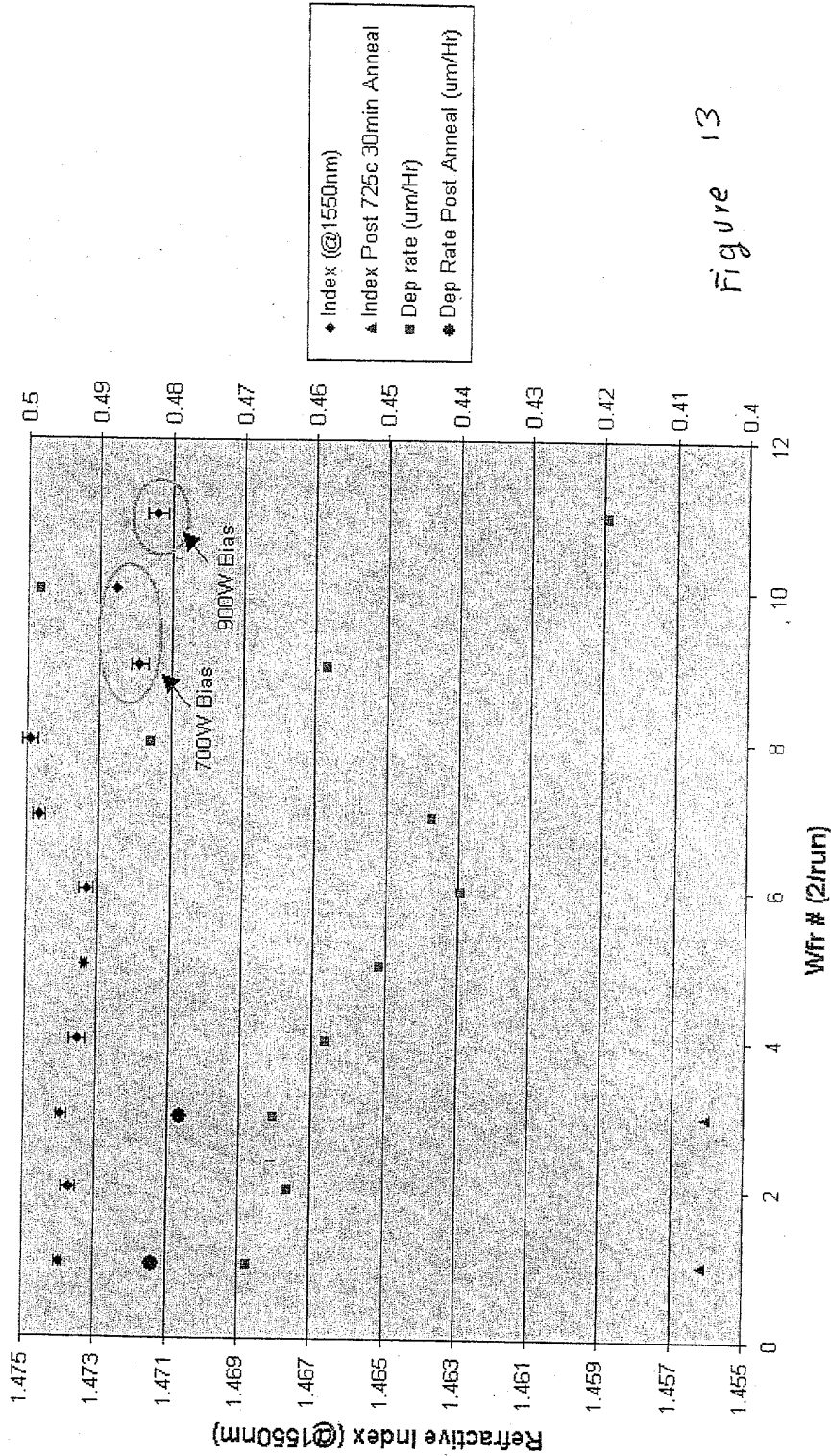


Figure 13

m-18 245 US  
11/27

Index Drift Control Target Comp. 83-17  
(ACT-1600 based reactor)

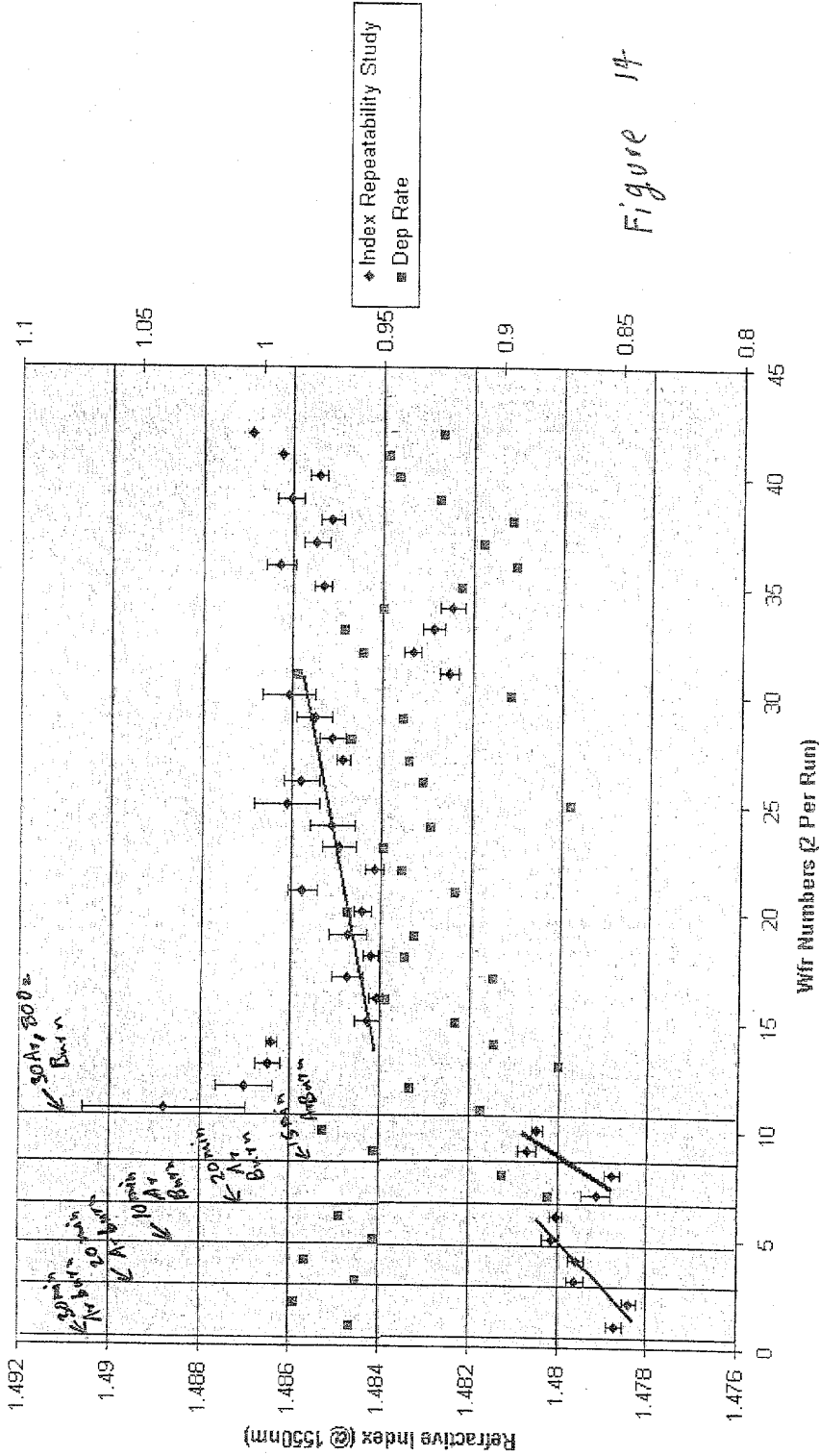


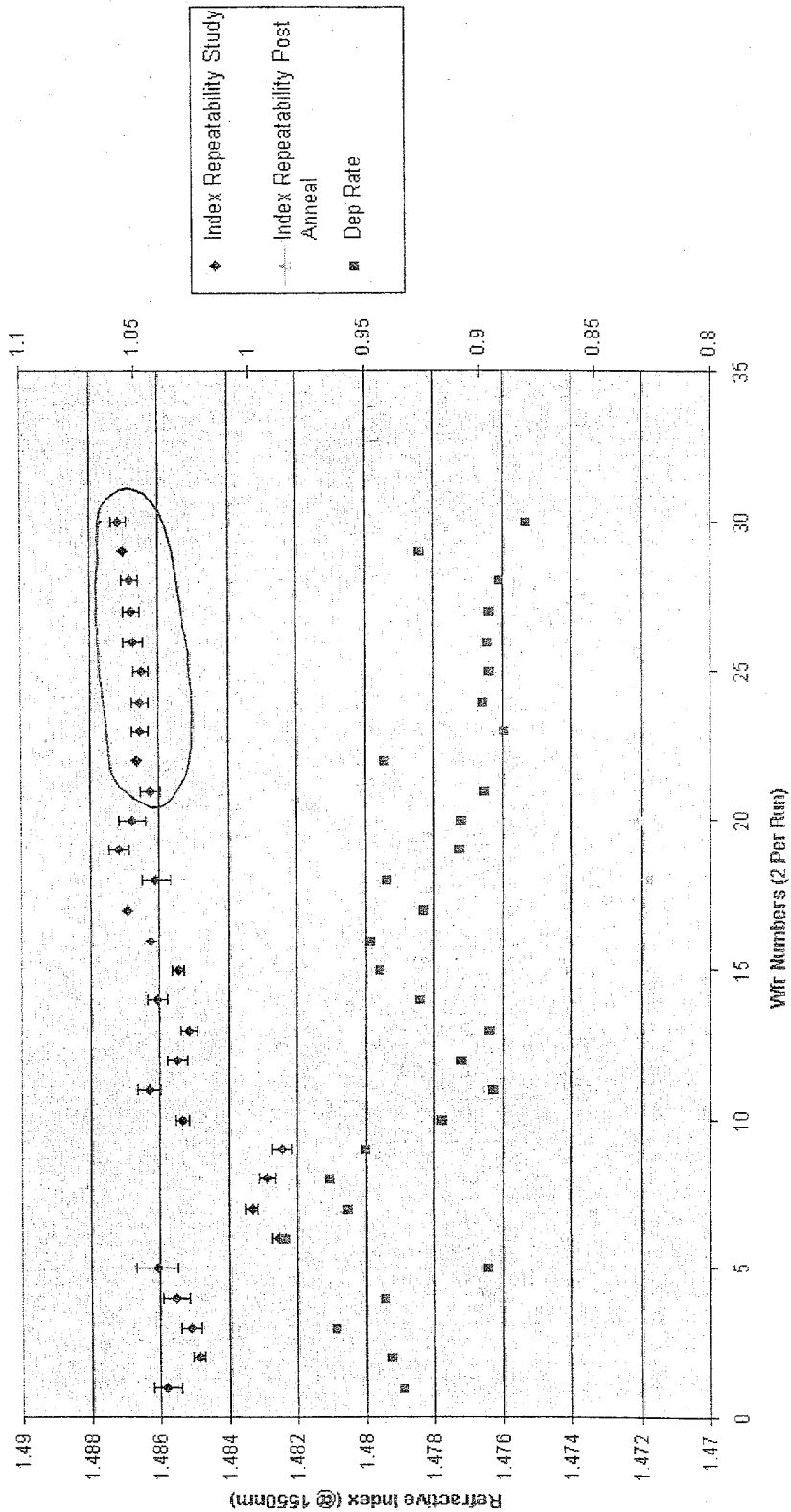
Figure 14

m-12245 US 12/27

209700-0000000000

83-17 Target / AKT 1600 based reactor.

### Index Drift Control



M-12245 US 13/27

Figure 15

M-12245 US  
14/27

10101893 031602

1601

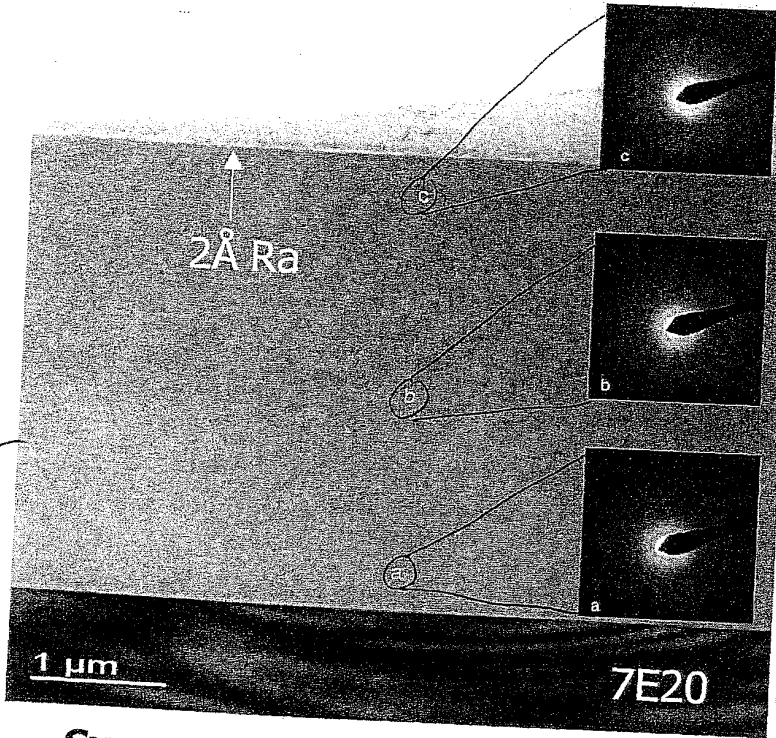


Figure 16 D

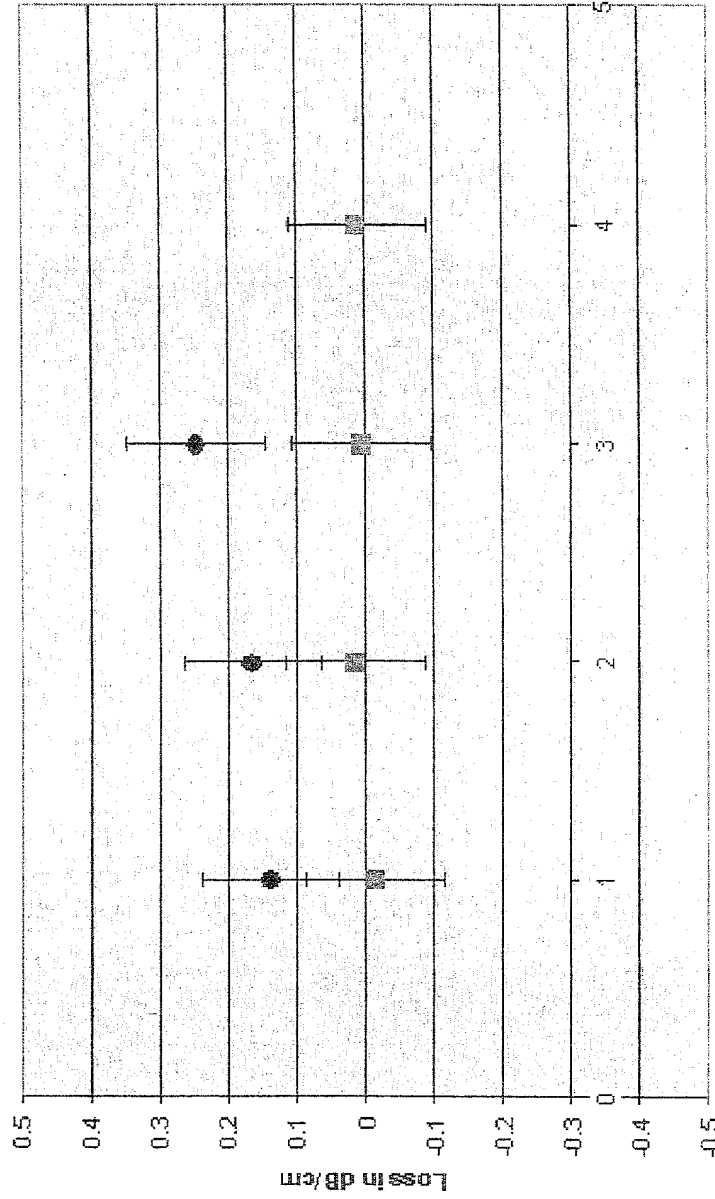
Figure 16 C

Figure 16 B

**Symmorphix PVD aluminosilicate**

Figure 16 A

2097ED E880F0F



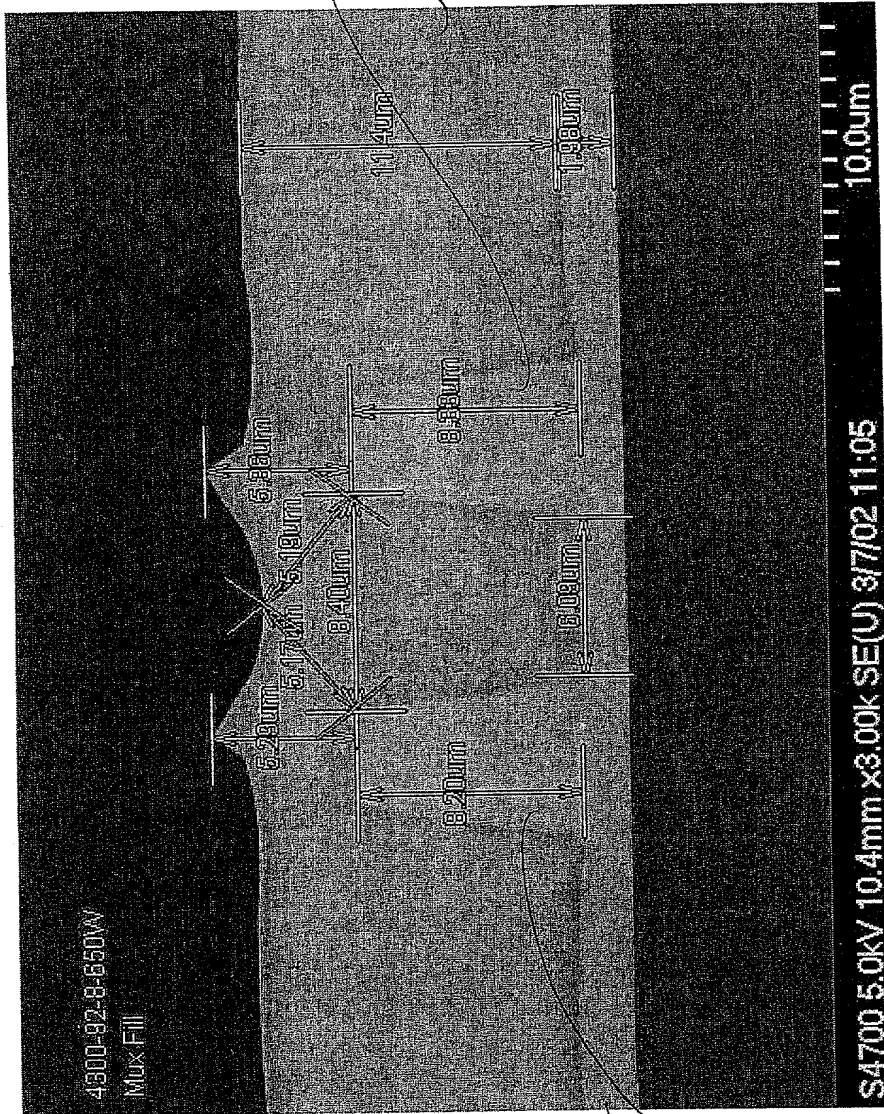
Path (cm)

● #8 - unannealed ■ #7 - annealed

Figure 17

m - 18245 US  
15/27

209160" E98FOFF



11.4um

8.20um

1804

1801

1802

1803

m-1245 US 16/99

Figure 18



m-12245 US  
17/27

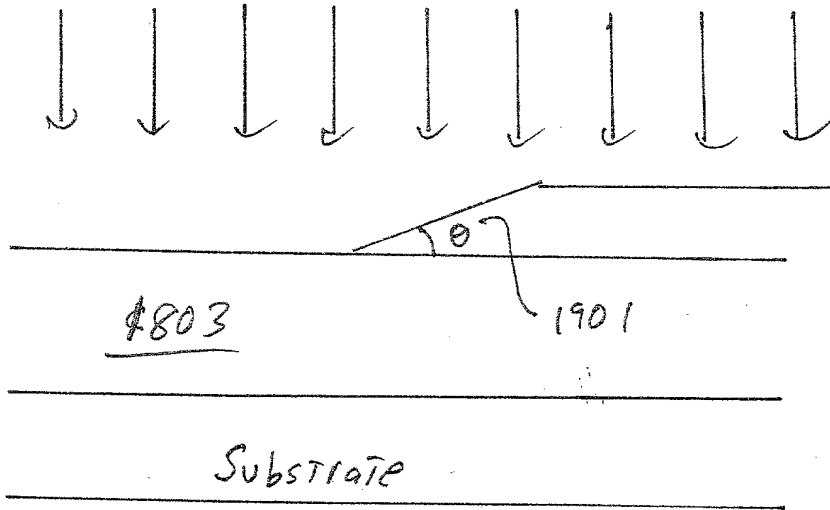


Figure 19

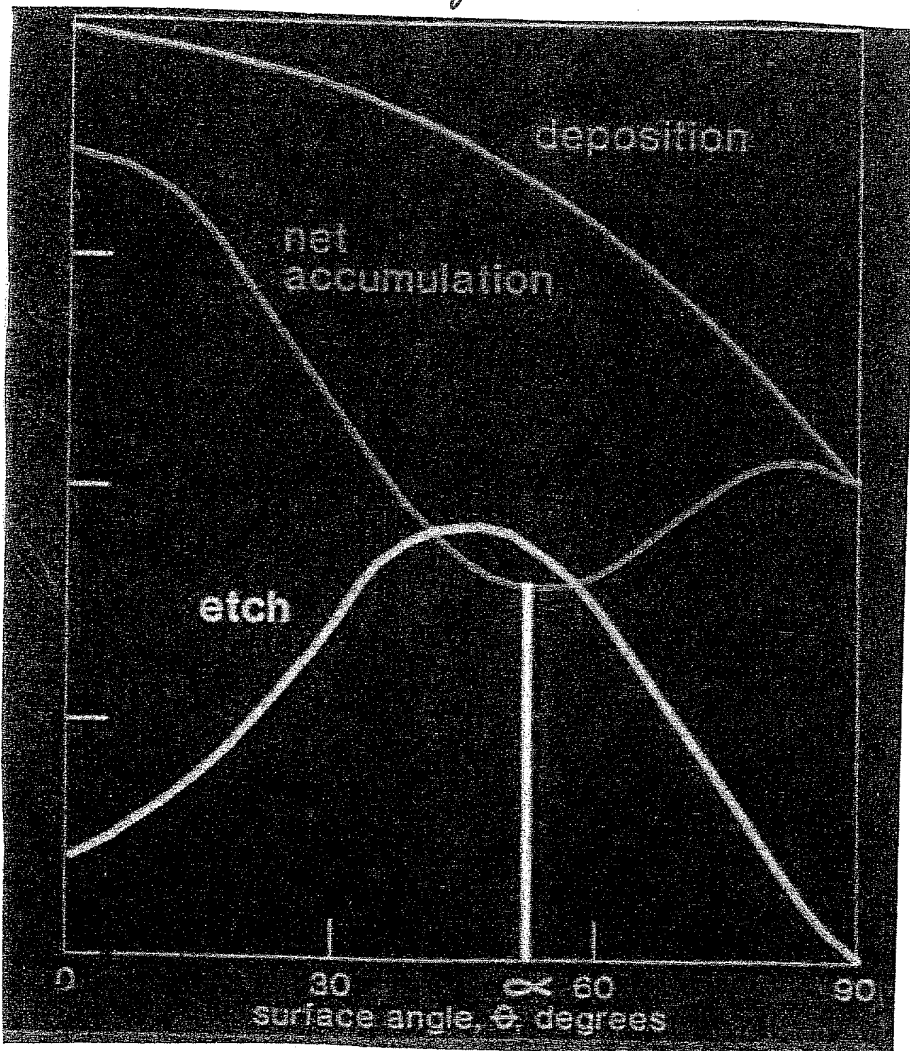


Figure  
20

209500-034600

m-10 245 05  
18/27

209760-034602

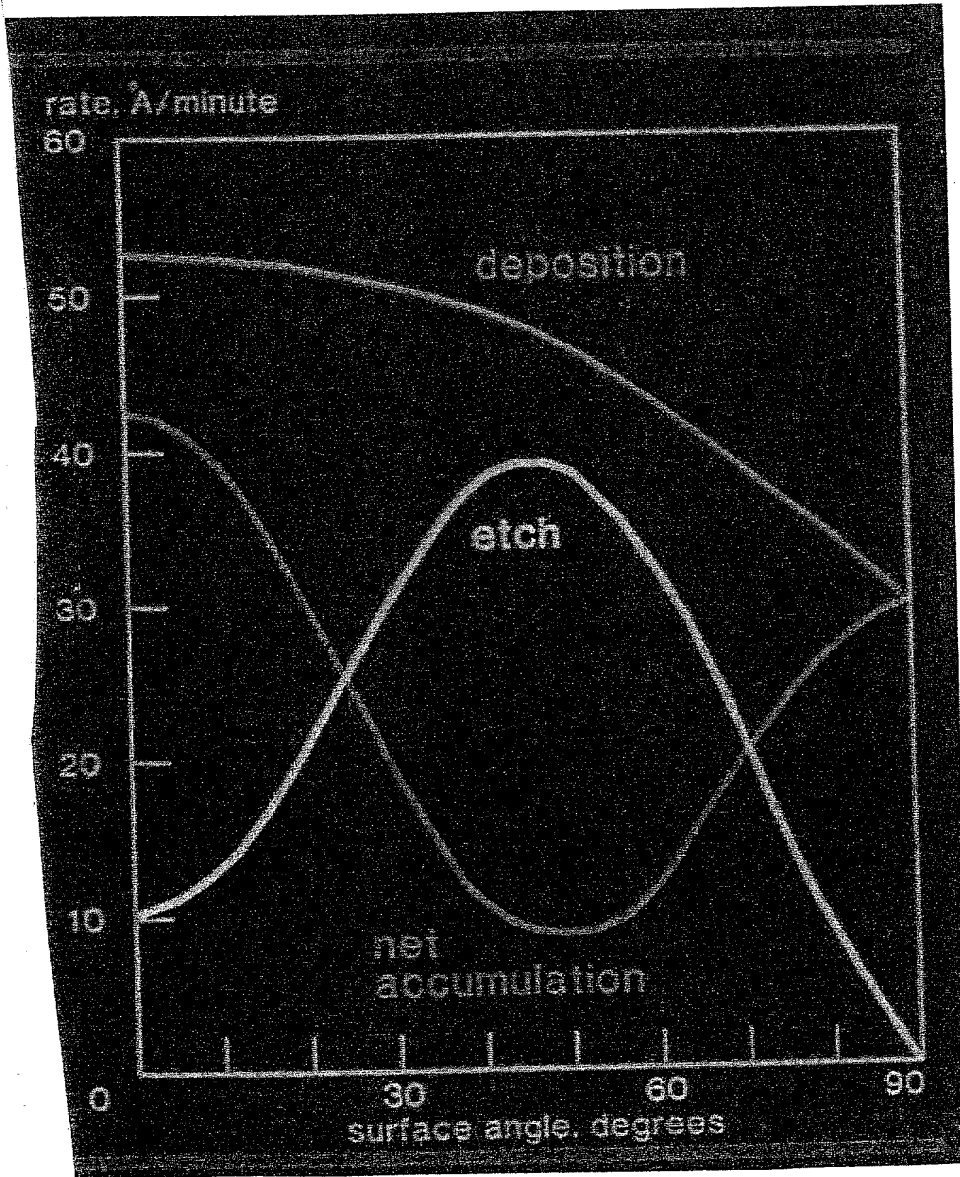


Figure 21

m-12245 US  
19/27

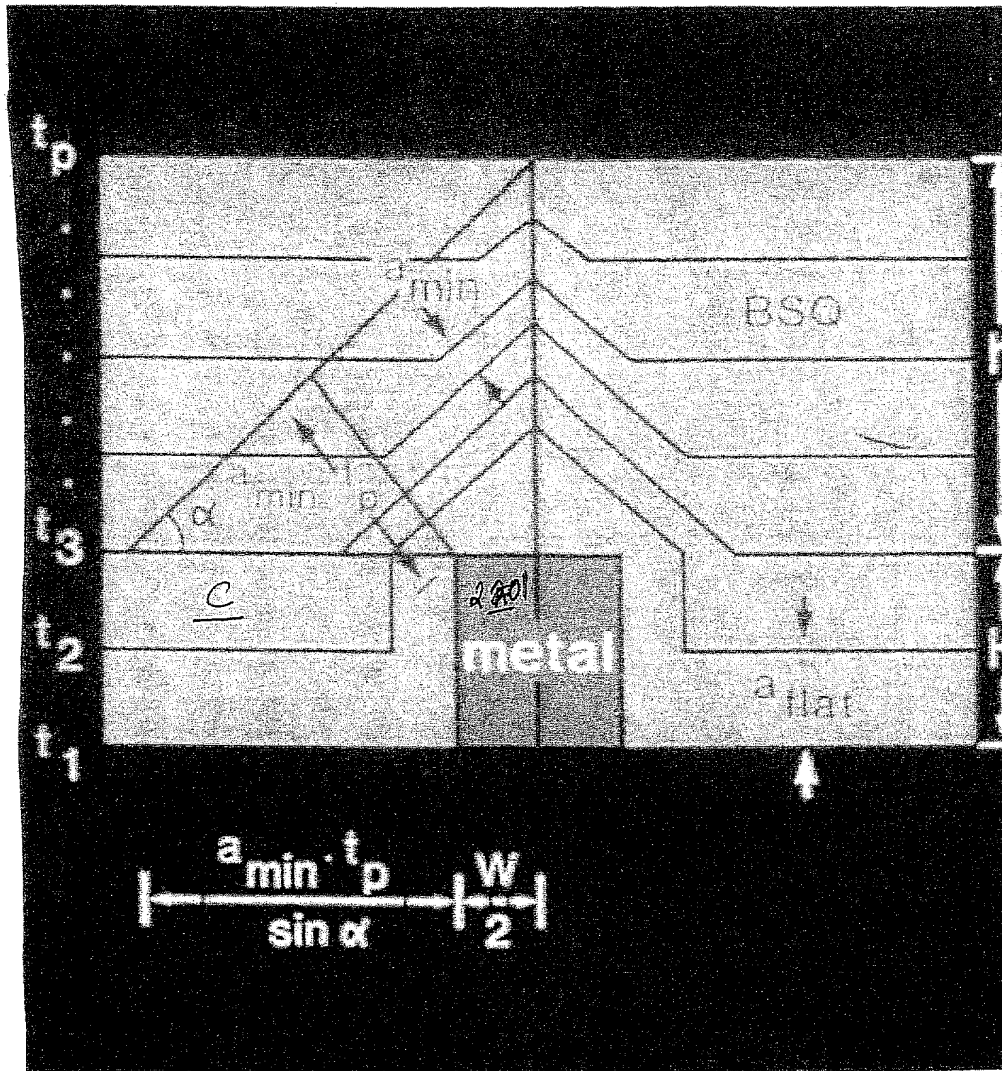


Figure 22

M-12 245 US  
20/27

20250308 14:00:00

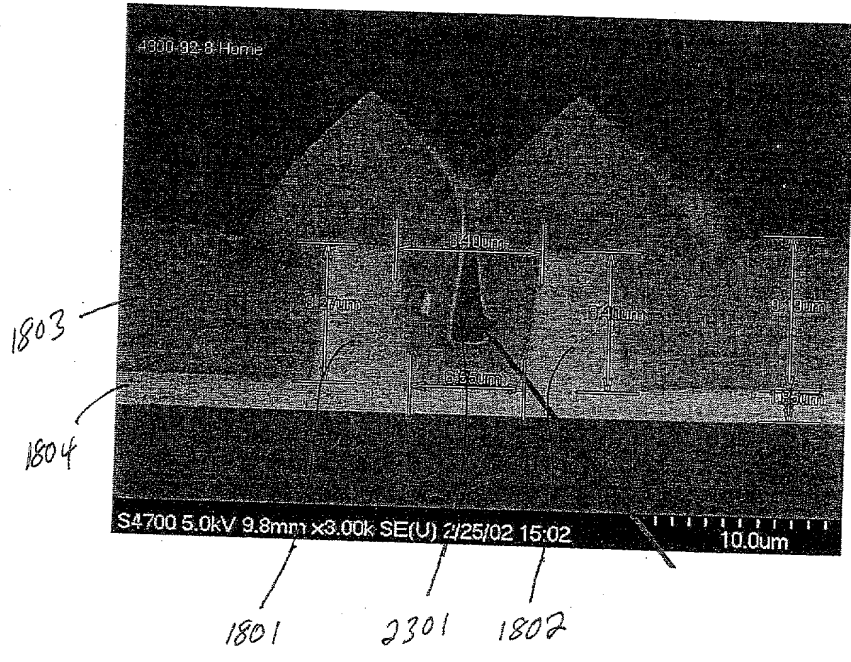
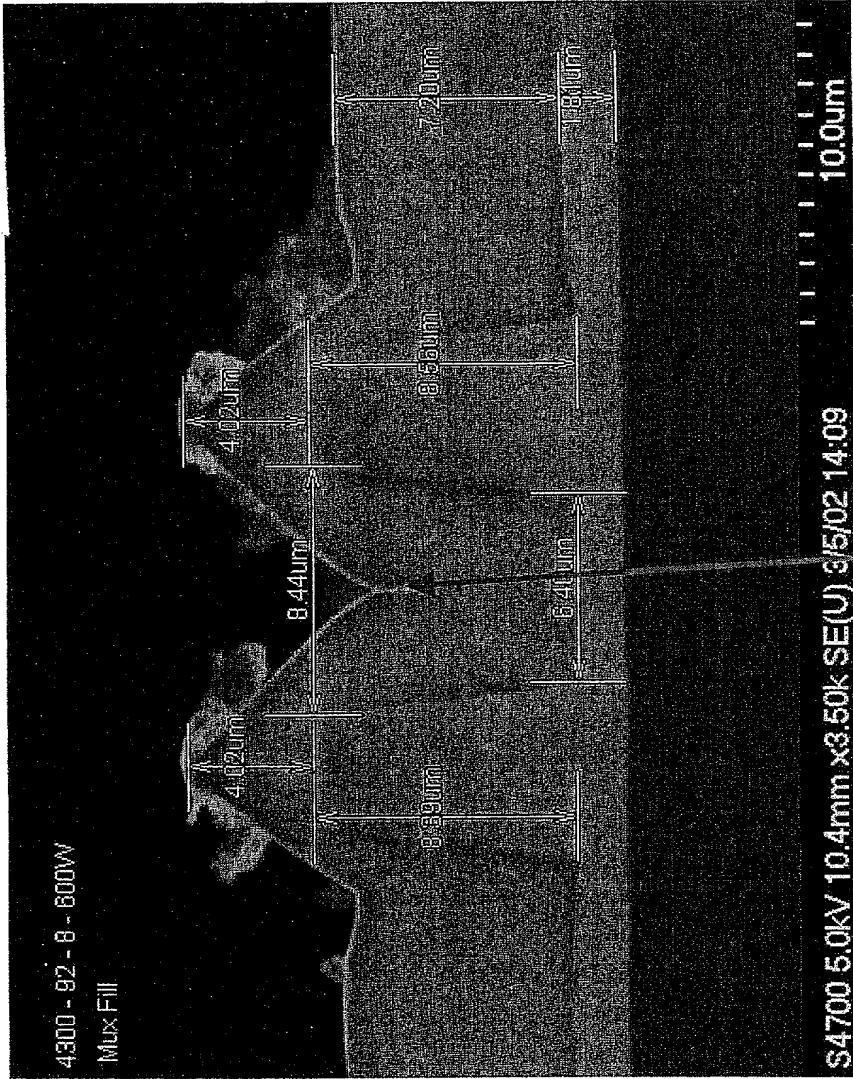


Figure 23

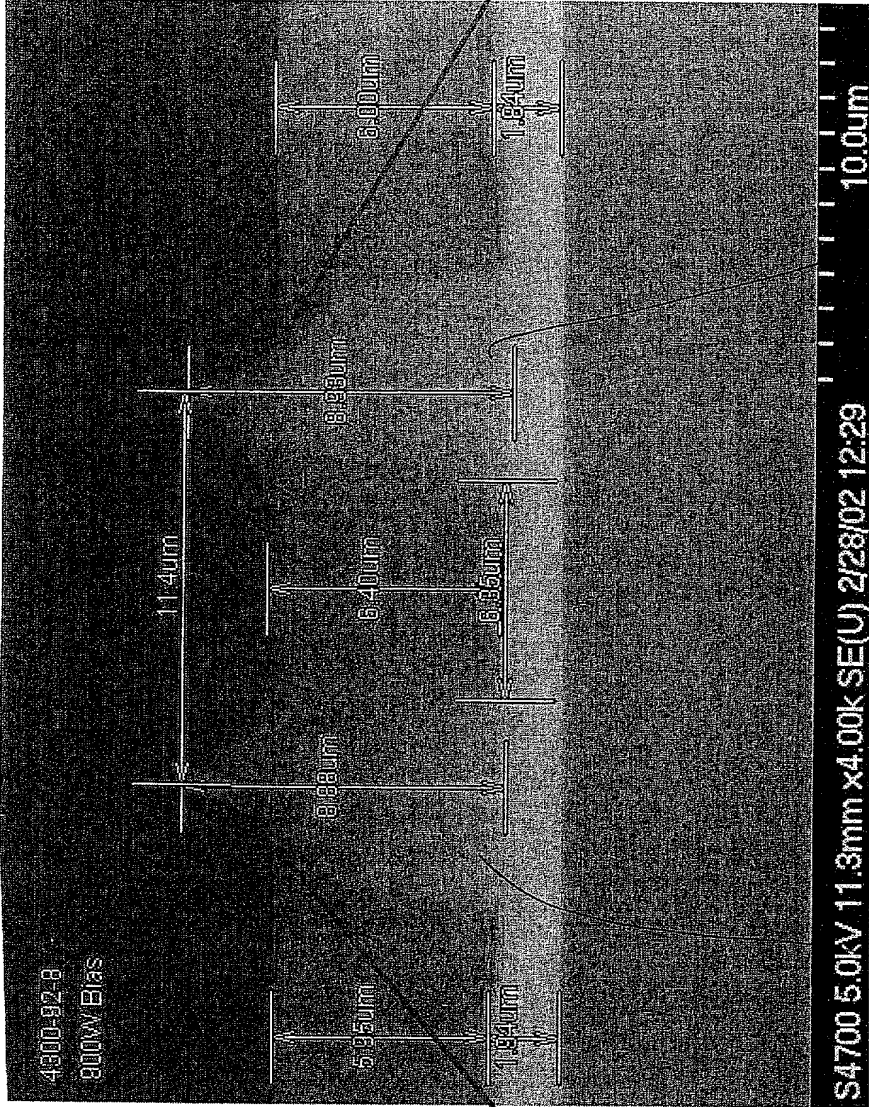
209TE0\*E98T0T0T



50 548 81 - 64  
2/10/02

Figure 24

2057E0 E98F0F0F



2058

2051

1802

1801

Figure 25

m-1245 us te/ee

m- 12245 US  
23/27

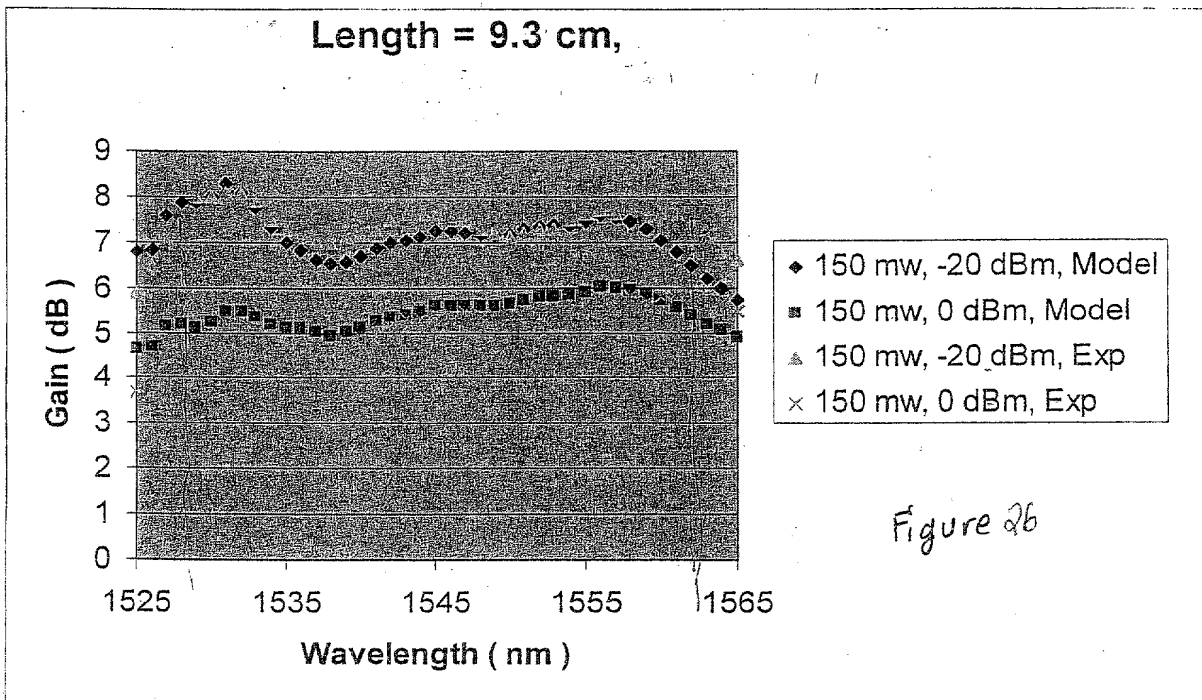


Figure 26

209700-98870101

m-12 24S US  
24/27

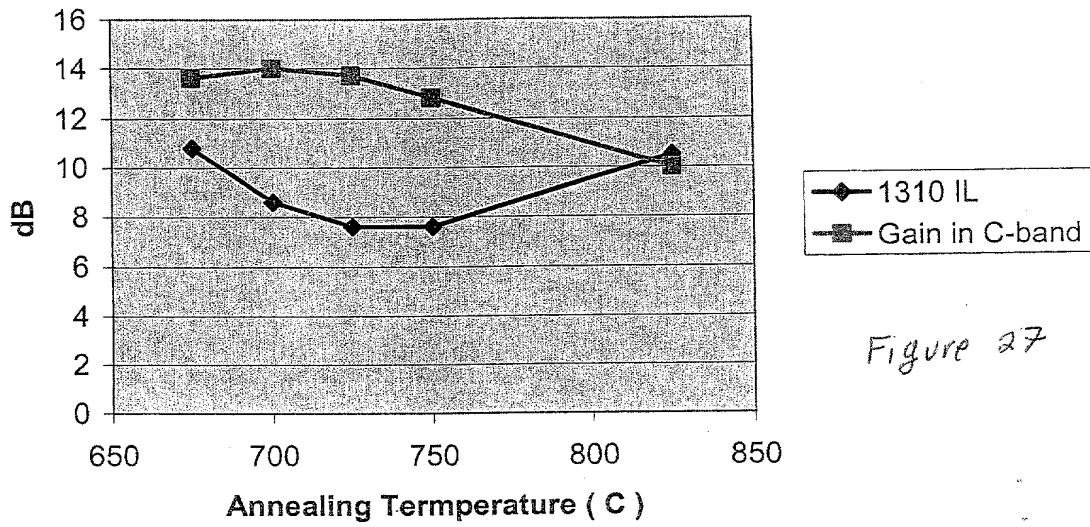
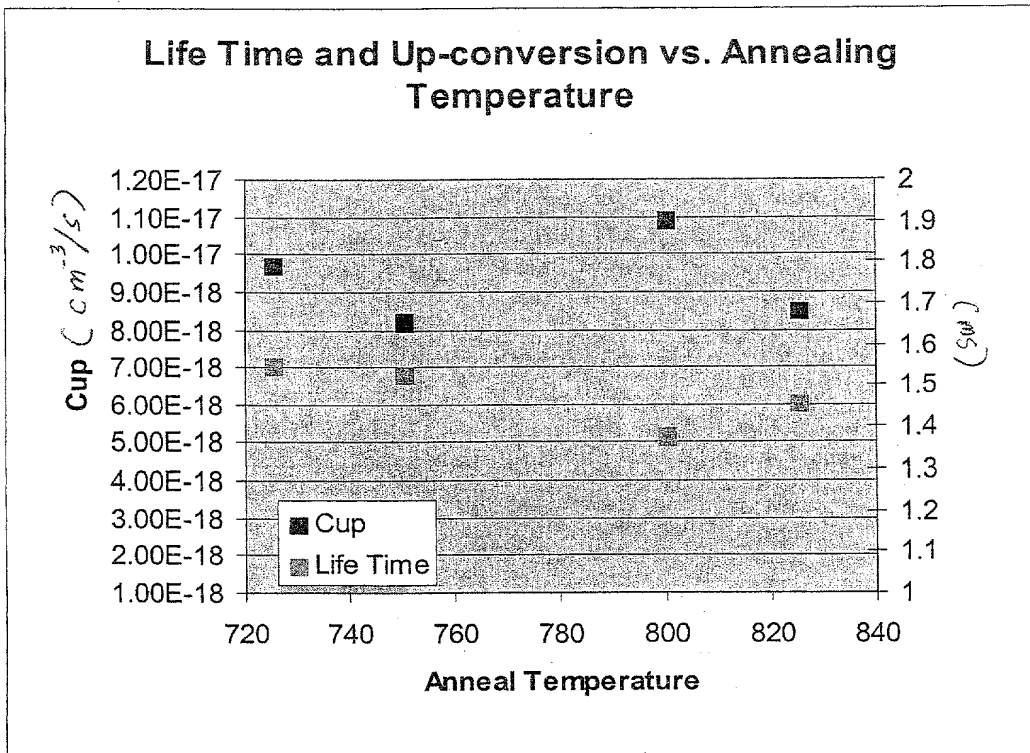


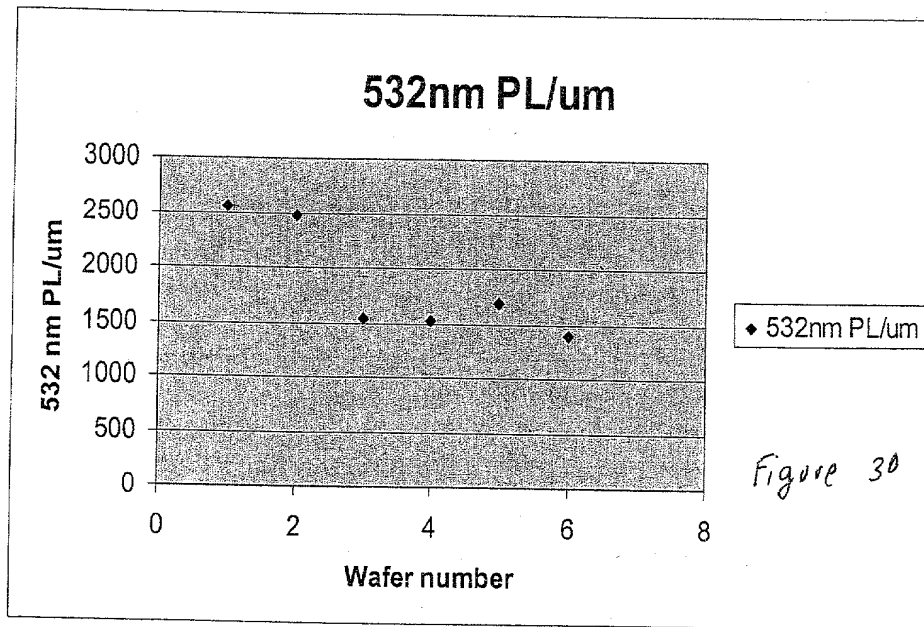
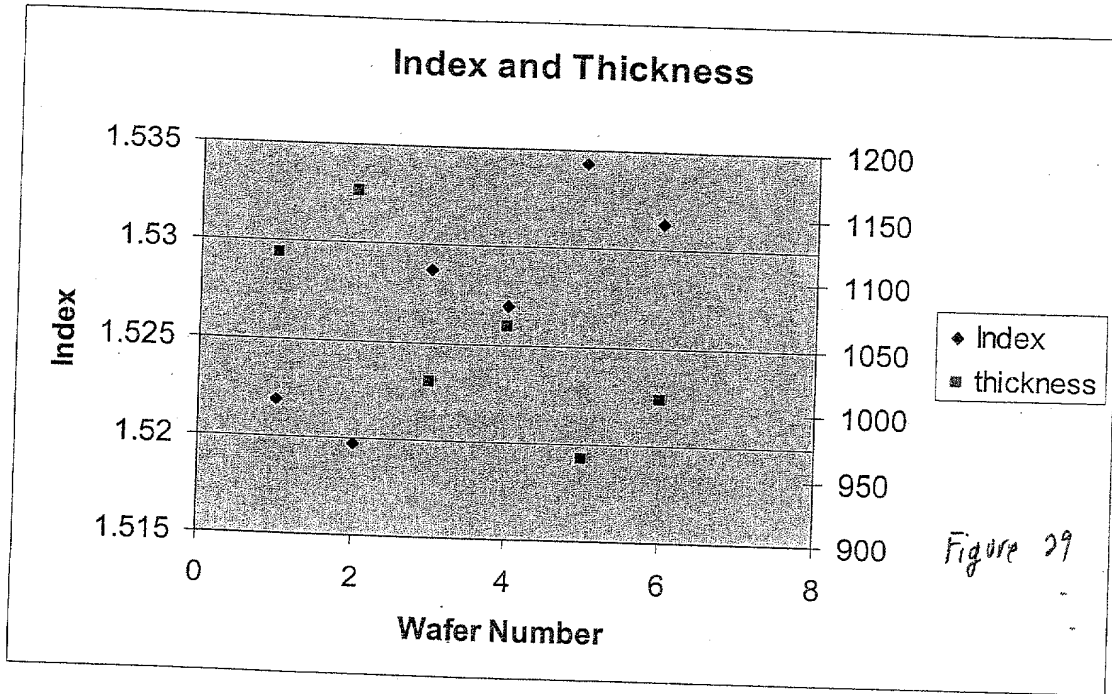
Figure 27

Figure 28



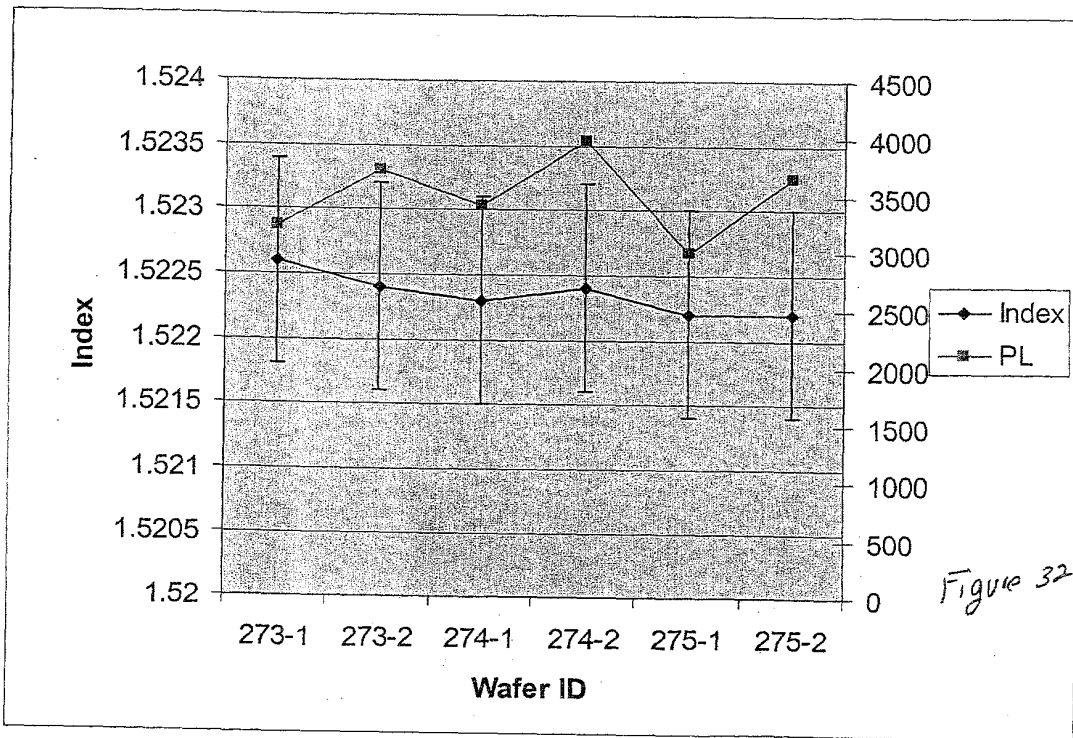
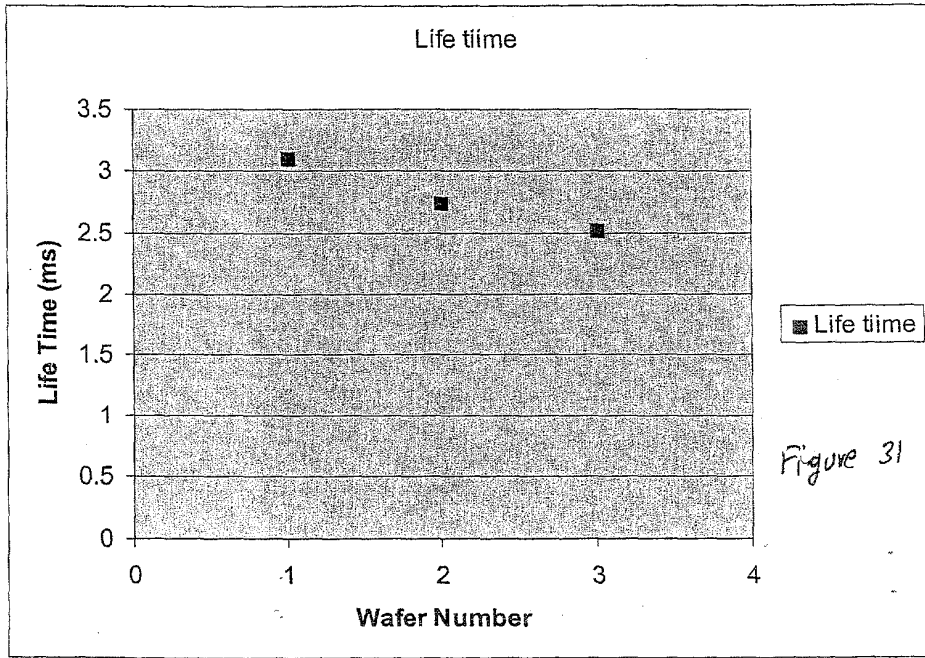


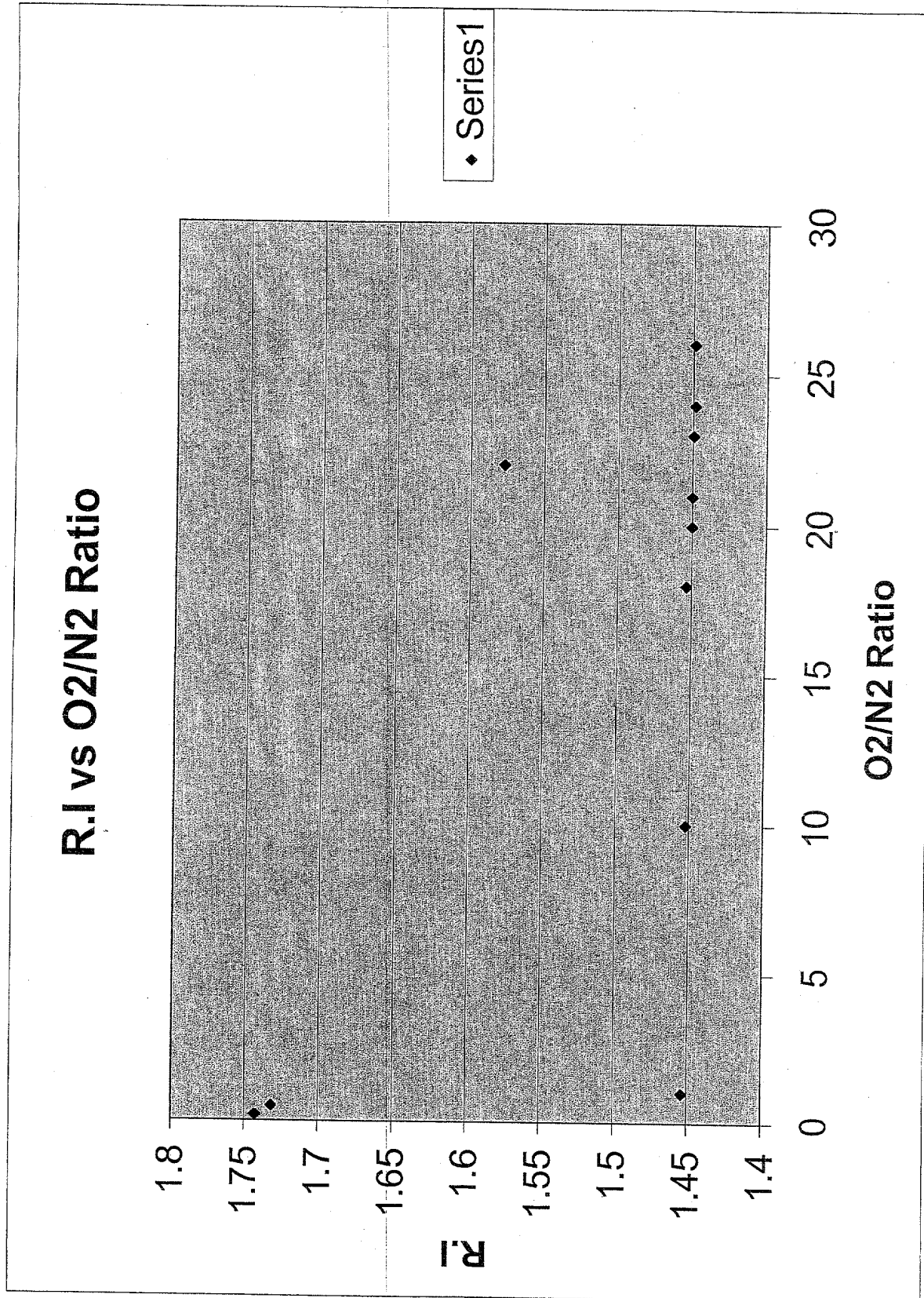
M-12 245 05  
25/27



10104863-034602

m-12245 US  
26/27





EC/EC  
SP sheet - w

Figure 33

**DECLARATION FOR PATENT APPLICATION  
AND POWER OF ATTORNEY**

As a below named inventor, I hereby declare that:

My residence, post office address and citizenship are as stated below adjacent to my name.

I believe I am the original, first and sole inventor (if only one name is listed below) or an original, first and joint inventor (if plural names are listed below) of subject matter (process, machine, manufacture, or composition of matter, or an improvement thereof) which is claimed and for which a patent is sought by way of the application entitled

**Biased Pulse DC Reactive Sputtering of Oxide Films**

- which (check)  is attached hereto.  
 and is amended by the Preliminary Amendment attached hereto.  
 was filed on      as Application Serial No.  
 and was amended on      (if applicable).

I hereby state that I have reviewed and understand the contents of the above identified specification, including the claims, as amended by any amendment referred to above.

I acknowledge the duty to disclose information, which is material to patentability as defined in Title 37, Code of Federal Regulations, § 1.56.

I hereby claim foreign priority benefits under Title 35, United States Code, § 119(a)-(d) of any foreign application(s) for patent or inventor's certificate or any PCT international application(s) designating at least one country other than the United States of America listed below and have also identified below any foreign application(s) for patent or inventor's certificate or any PCT international application(s) designating at least one country other than the United States of America filed by me on the same subject matter having a filing date before that of the application(s) of which priority is claimed:

Prior Foreign Application(s)			Priority Claimed	
Number	Country	Day/Month/Year Filed	Yes	No
N/A			<input type="checkbox"/>	<input type="checkbox"/>

I hereby claim the benefit under Title 35, United States Code, § 119(e) of any United States provisional application(s) listed below:

Provisional Application Number	Filing Date
N/A	

I hereby claim the benefit under Title 35, United States Code, § 120 of any United States application(s) or PCT international application(s) designating the United States of America listed below and, insofar as the subject matter of each of the claims of this application is not disclosed in the prior application(s) in the manner provided by the first paragraph of Title 35, United States Code, § 112, I acknowledge the duty to disclose information, which is material to patentability as defined in Title 37, Code of Federal Regulations, § 1.56, which became available between the filing date of the prior application(s) and the national or PCT international filing date of this application:

Application Serial No.	Filing Date	Status (patented, pending, abandoned)
N/A		

ACCEPTED FOR FILING

I hereby appoint the following practitioners to prosecute this application and to transact all business in the United States Patent and Trademark Office connected therewith:

Customer Number 24251



Please direct all telephone calls to:

Gary J. Edwards

Telephone: 408-453-9200

I declare that all statements made herein of my own knowledge are true, all statements made herein on information and belief are believed to be true, and all statements made herein are made with the knowledge that whoever, in any matter within the jurisdiction of the Patent and Trademark Office, knowingly and willfully falsifies, conceals, or covers up by any trick, scheme, or device a material fact, or makes any false, fictitious or fraudulent statements or representations, or makes or uses any false writing or document knowing the same to contain any false, fictitious or fraudulent statement or entry, shall be subject to the penalties including fine or imprisonment or both as set forth under 18 U.S.C. 1001, and that violations of this paragraph may jeopardize the validity of the application or this document, or the validity or enforceability of any patent, trademark registration, or certificate resulting therefrom.

2009 FEB 20 10 49 AM

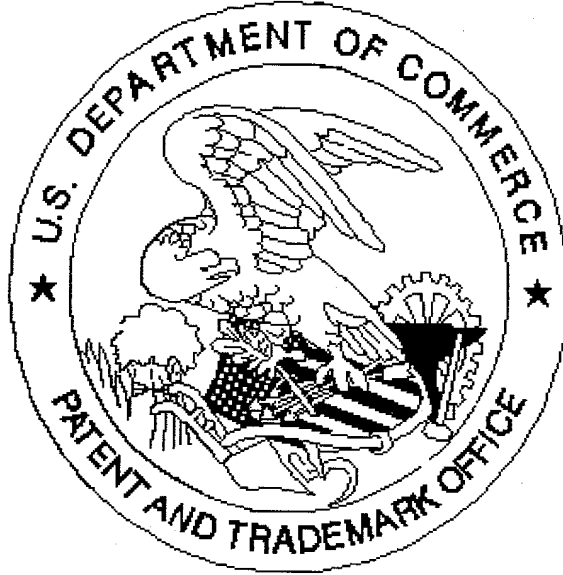
Full name of **first** joint inventor: Hongmei Zhang  
Inventor's Signature: \_\_\_\_\_ Date: \_\_\_\_\_  
Residence: \_\_\_\_\_  
Post Office Address: \_\_\_\_\_ Citizenship: \_\_\_\_\_

Full name of **third** joint inventor: Mukundan Narasimhan  
Inventor's Signature: \_\_\_\_\_ Date: \_\_\_\_\_  
Residence: \_\_\_\_\_  
Post Office Address: \_\_\_\_\_ Citizenship: \_\_\_\_\_

Full name of **second** joint inventor: Ravi B. Mullapudi  
Inventor's Signature: \_\_\_\_\_ Date: \_\_\_\_\_  
Residence: San Jose, California  
Post Office Address: 2117 Shiangzone Court San Jose, California 95121  
Citizenship: India

Full name of **fourth** joint inventor: Richard E. Demaray  
Inventor's Signature: \_\_\_\_\_ Date: \_\_\_\_\_  
Residence: Portola Valley, California  
Post Office Address: 190 Fawn Lane Portola Valley, California 94028  
Citizenship: USA

United States Patent & Trademark Office  
Office of Initial Patent Examination -- Scanning Division



Application deficiencies found during scanning:

Page(s) \_\_\_\_\_ of \_\_\_\_\_ were not present  
for scanning. (Document title)

Page(s) \_\_\_\_\_ of \_\_\_\_\_ were not present  
for scanning. (Document title)

*Scanned copy is best available. Drawing are dark.*

**BEST AVAILABLE COPY**

PATENT NUMBER and  
ISSUE DATE

**U.S. UTILITY Patent Application**

APPL NUM 10101863	FILING DATE 03/16/2002	CLASS 230	SUBCLASS 425	GAU 2847	EXAMINER ESTRADA FAMMY
----------------------	---------------------------	--------------	-----------------	-------------	------------------------------

**\*\*APPLICANTS:** Zhang Hongmei; Narasimhan Mukundan; Mullapudi Ravi; Demaray Richard;

**\*\*CONTINUING DATA VERIFIED:**

**\*\* FOREIGN APPLICATIONS VERIFIED:**

PG-PUB	DO NOT PUBLISH <input type="checkbox"/>	RESCIND <input type="checkbox"/>	ATTORNEY DOCKET NO M-12245 US
Foreign priority claimed	<input type="checkbox"/> yes <input type="checkbox"/> no		
35 USC 119 conditions met	<input type="checkbox"/> yes <input type="checkbox"/> no		
Verified and Acknowledged Examiners's initials			
TITLE : Biased pulse DC reactive sputtering of oxide films			

U.S. DEPT. OF COMM./PAT. & TM-PTO-436L (Rev. 12-94)

<b>NOTICE OF ALLOWANCE MAILED</b>		<b>Assistant Examiner</b>	<b>CLAIMS ALLOWED</b>		
			Total Claims	Print Claim for O.G.	
<b>ISSUE FEE</b>			<b>DRAWING</b>		
Amount Due	Date Paid	<b>Primary Examiner</b>	Sheets Drwg.	Figs. Drwg.	Print Fig.
			<b>Application Examiner</b>		
<input type="checkbox"/> <b>TERMINAL</b>		<b>PREPARED FOR ISSUE</b>			
<b>DISCLAIMER</b>		<p><b>WARNING:</b> The information disclosed herein may be restricted. Unauthorized disclosure may be prohibited by the United States Code Title 35, Sections 122, 181 and 368, Possession outside the U.S. Patent &amp; Trademark Office is restricted to authorized employees and contractors only.</p>			

FILED WITH:  DISK (CRF)  CD-ROM  
(Attached in pocket on right inside flap)

10101863  
 03/16/02  
 230  
 425  
 2847





ISSUE SLIP STAPLE AREA (for additional cross-references)

ISSUING CLASSIFICATION			
ORIGINAL		CLASS	SUBCLASS (ONE SUBCLASS PER BLOCK)
CLASS	SUBCLASS		

^ Continued on Issue Slip Inside File Jacket

**INDEX OF CLAIMS**

✓ ..... Rejected - (Through numeral) ... Canceled N ..... Non-elected A ..... Appeal  
 = ..... Allowed + ..... Restricted I ..... Interference O ..... Objected

Claim	Final	Original	Date
1			
2			
3			
4			
5			
6			
7			
8			
9			
10			
11			
12			
13			
14			
15			
16			
17			
18			
19			
20			
21			
22			
23			
24			
25			
26			
27			
28			
29			
30			
31			
32			
33			
34			
35			
36			
37			
38			
39			
40			
41			
42			
43			
44			
45			
46			
47			
48			
49			
50			

Claim	Final	Original	Date
51			
52			
53			
54			
55			
56			
57			
58			
59			
60			
61			
62			
63			
64			
65			
66			
67			
68			
69			
70			
71			
72			
73			
74			
75			
76			
77			
78			
79			
80			
81			
82			
83			
84			
85			
86			
87			
88			
89			
90			
91			
92			
93			
94			
95			
96			
97			
98			
99			
100			

Claim	Final	Original	Date
101			
102			
103			
104			
105			
106			
107			
108			
109			
110			
111			
112			
113			
114			
115			
116			
117			
118			
119			
120			
121			
122			
123			
124			
125			
126			
127			
128			
129			
130			
131			
132			
133			
134			
135			
136			
137			
138			
139			
140			
141			
142			
143			
144			
145			
146			
147			
148			
149			
150			

BEST AVAILABLE COPY

If more than 150 claims or 9 actions staple additional sheet here

03/16/02  
JC658 U.S. PTO

25 Metro Drive  
Suite 700

San Jose  
California 95110

T: 408-453-9200  
F: 408-453-7979

Austin, TX  
Newport Beach, CA  
San Francisco, CA

skjerven morrill  
macpherson LLP

Docket No.: M-12245 US

March 16, 2002

11017 U.S. PTO  
10/101863  
03/16/02

Box Patent Application  
Commissioner For Patents  
Washington, D. C. 20231

Enclosed herewith for filing is a patent application, as follows:

Inventor(s): Zhang, Hongmei; Narasimhan, Mukundan; Mullanpudi, Ravi; and Demaray, Richard E.

Title: **Biased Pulse DC Reactive Sputtering of Oxide Films**

- Return Receipt Postcard
- This Transmittal Letter (in duplicate)
- 2 page(s) Declaration For Patent Application and Power of Attorney (unsigned)
- 34 page(s) Specification (not including claims)
- 4 page(s) Claims
- 1 page Abstract
- 27 Sheet(s) of Drawings

Applicant(s) assert(s) entitlement to small entity status for the attached patent application

**CLAIMS AS FILED (fees computed under 37 CFR §1.9(f))**

For	Number Filed		Number Extra		Rate		Basic Fee
Total Claims	39	-20 =	9	x	\$ 9.00 =	\$	370.00
Independent Claims	5	-3 =	2	x	\$42.00 =	\$	84.00
<input type="checkbox"/> Fee of _____ for the first filing of one or more multiple dependent claims per application						\$	
<input type="checkbox"/> Fee for Request for Extension of Time						\$	

Please make the following charges to Deposit Account 19-2386:

- Total fee for filing the patent application in the amount of \$ 525.00
- The Commissioner is hereby authorized to charge any additional fees which may be required, or credit any overpayment to Deposit Account 19-2386.

EXPRESS MAIL LABEL NO:  
EL 941 069 152 US

Respectfully submitted,  
*Gary J. Edwards*  
Gary J. Edwards  
Attorney for Applicant(s)  
Reg. No. 41,008

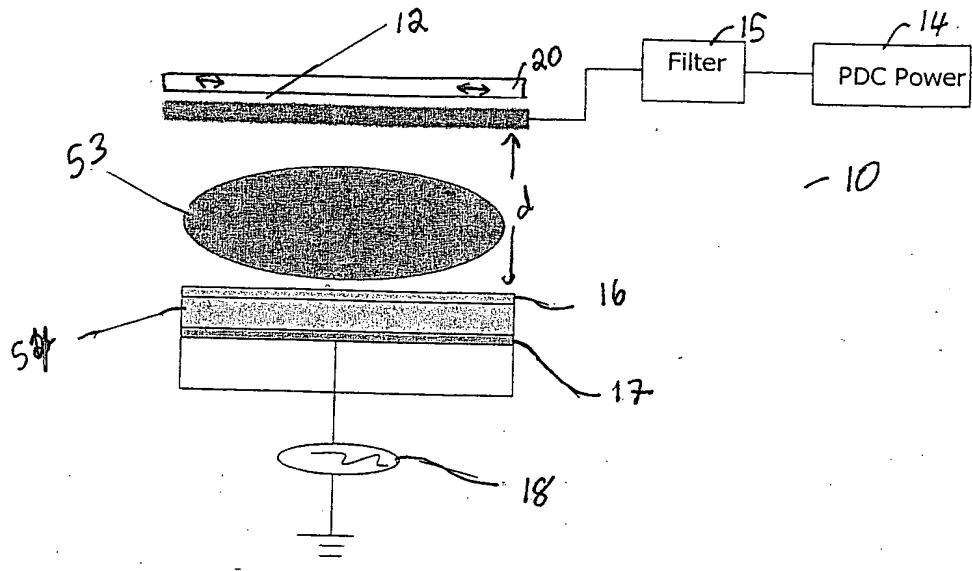


Figure 1A

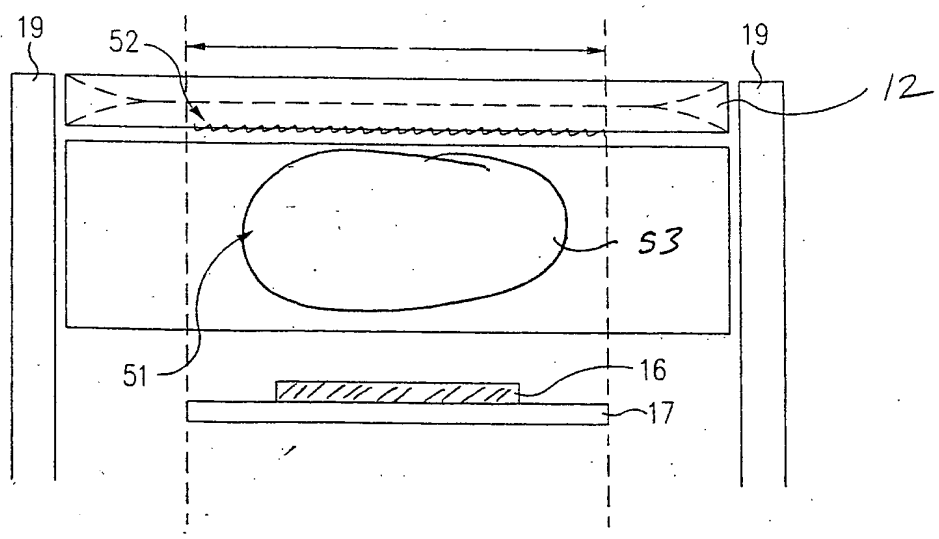


FIG. 1B

PHOTOCOPIED

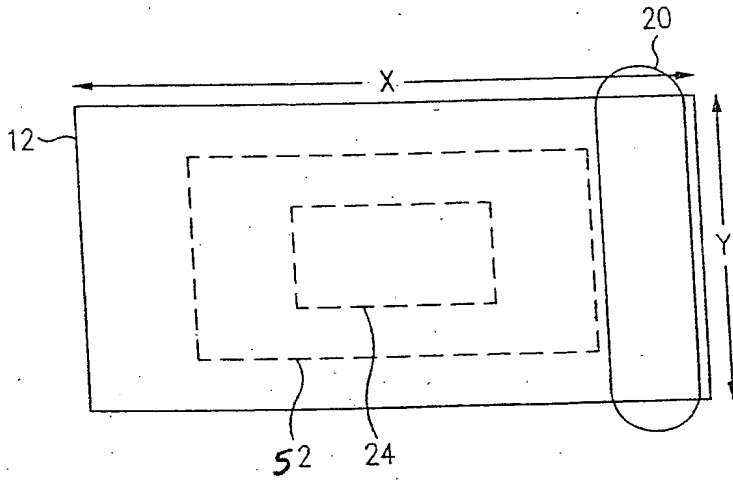


FIG. 2

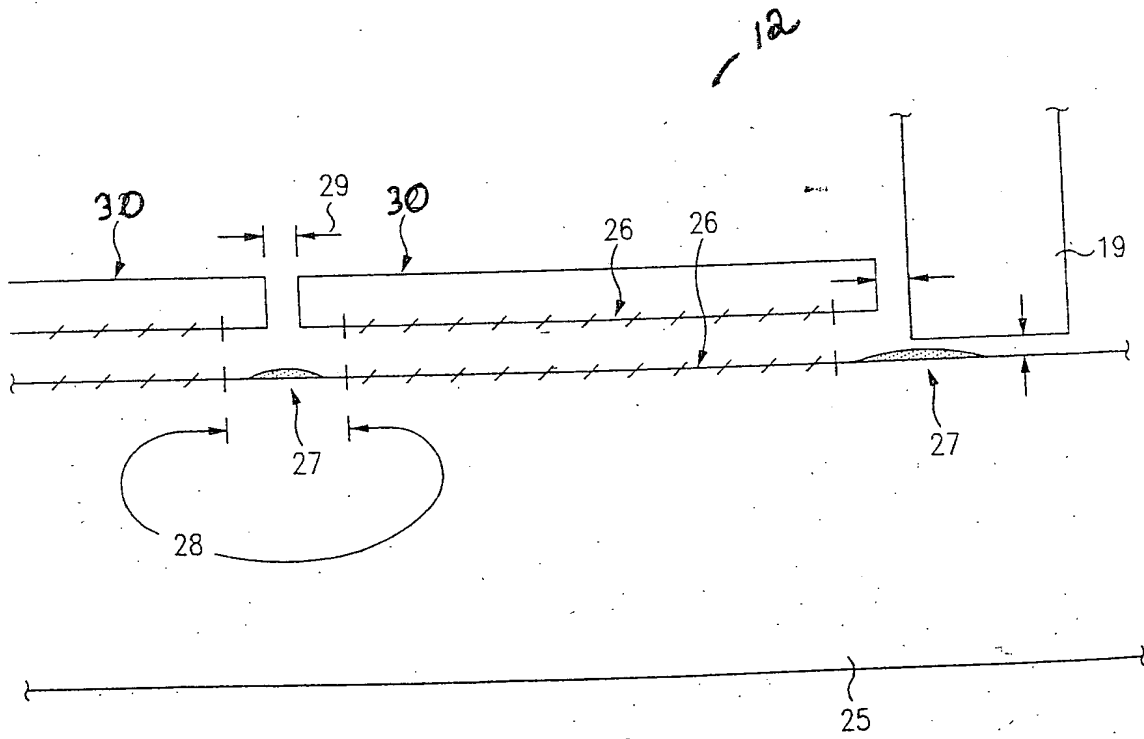


FIG. 3

2025 RELEASE UNDER E.O. 14176

m- 12245 US  
3/27

400

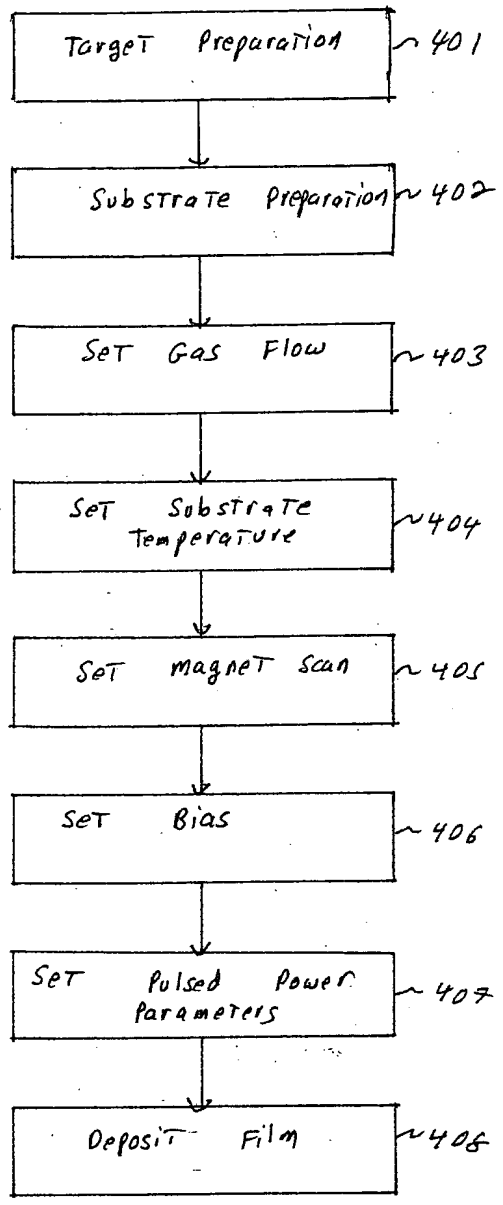


Figure 4

2025 RELEASE UNDER E.O. 14176

M-12245 US  
4/27

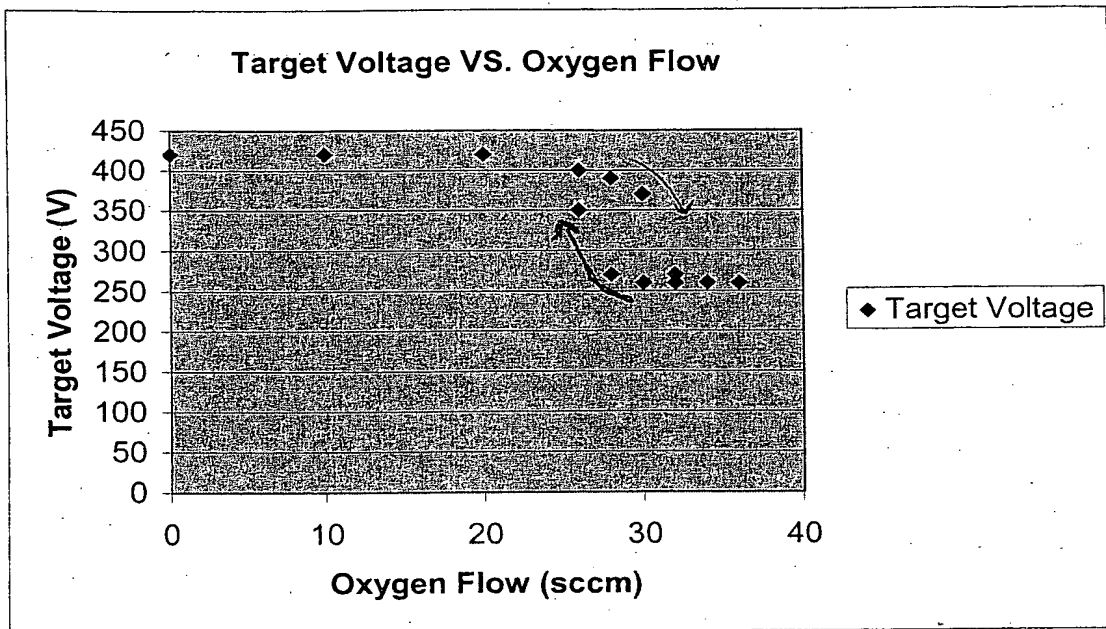


Figure 5

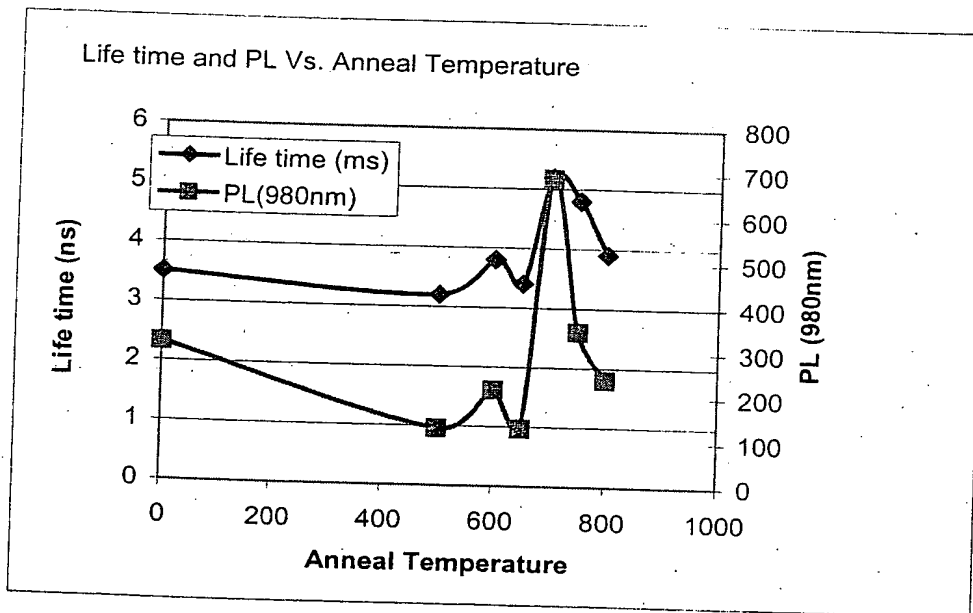
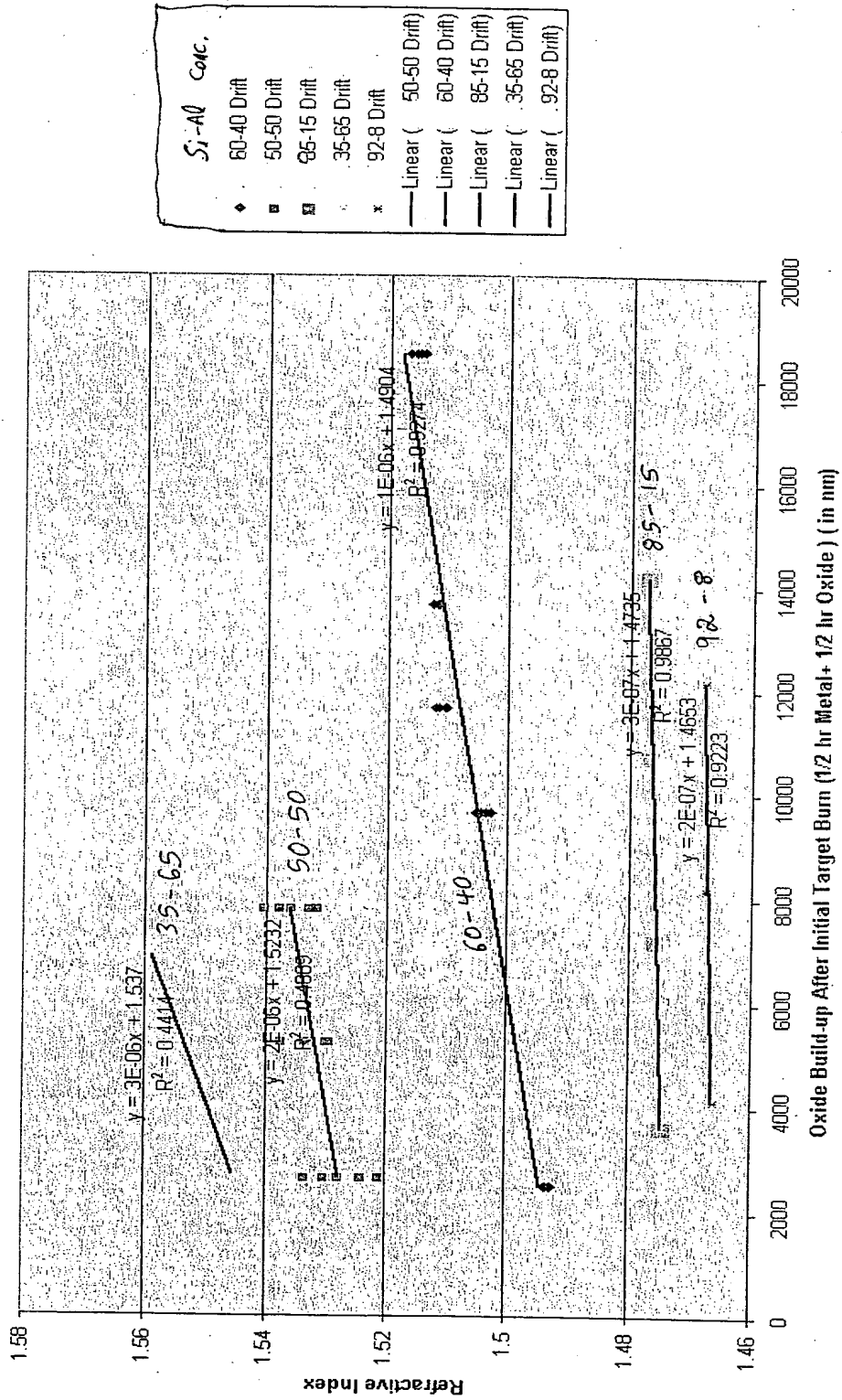


Figure 6

CONFIDENTIAL

2091E0\*E98F0F0F

Alumino Silicates Index Drift in Burn-in Cycle (As Deposited from Al/Si Cast Metal Targets)

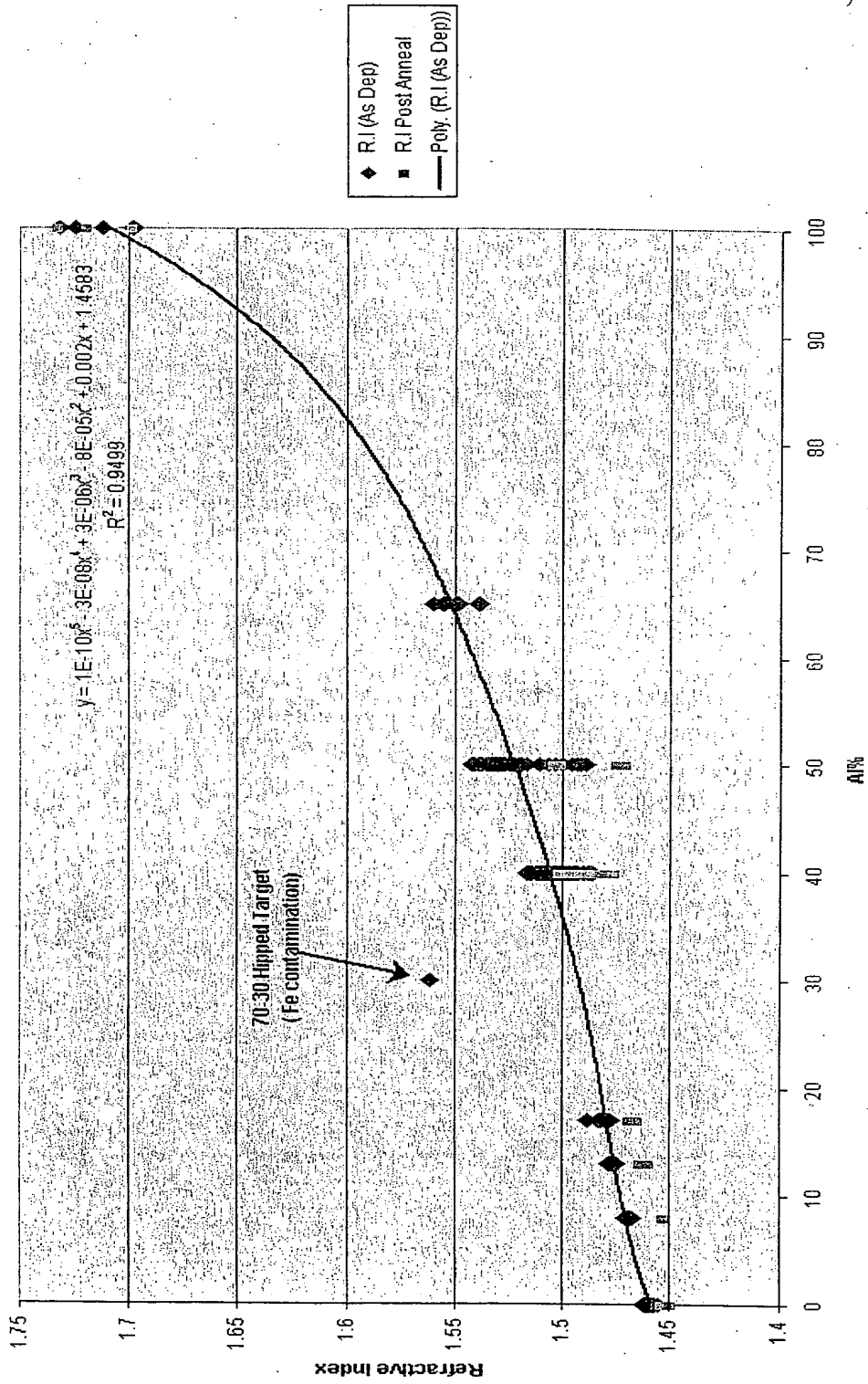


m-18245 US  
5/87

Figure 7

2097E0\*E9870707

Refractive Index as a function of Al% in Aluminosilicates



m-1245 US 6/27

Figure 8



Material (Er/Yb/Al/Si)	Expected index (Post anneal)	Actual index (Post anneal)	Process Conditions (Annealed 725c 30min)
0.8/0.8/41.4/57	1.506	1.510	6KW, Ar-60, O2-28scm, 120KHz, 2.2us, 60mm T-W Space, 4-5mm T-M Space, 0-400W Bias
1.6/0.5/49/48.9	1.526	1.528	6KW, Ar-60, O2-28scm, 120KHz, 2.2us, 60mm T-W Space, 4-5mm T-M Space, 0-400W Bias
0/0/8/92	1.452	1.456- 1.459	4.5KW, Ar-30-60, O2-28-44, 120-200KHz, 2.2us, 60-85mm T-W Space, 4-5mm T-M Space, 0-400W Bias
0/0/40/60	1.504	1.486- 1.501	3.0-4.5KW, Ar-30, O2-44, 75-200KHz, 2.2-3.0us, 60-85mm T-W Space, 4-5mm T-M Space, 0-400W Bias
0/0/50/50	1.520	1.491- 1.503	4.0-4.5KW, Ar-30, O2-44, 75-200KHz, 2.2-3.0us, 60-85mm T-W Space, 4-5mm T-M Space, 0-400W Bias
0/0/65/35	1.544	1.545- 1.560	4.5-5.5KW, Ar-75-90, O285-100, 200KHz, 2.2us, 85mm T-W Space, 4-5mm T-M Space, 0-400W Bias
0/0/30/70	1.490	1.562 (high Fe content)	5.0KW, Ar-75, O2-100, 200KHz, 2.2us, 85mm T-W Space, 4-5mm T-M Space, 0-400W Bias
1.5/0/48.5/50	1.523	1.509- 1.513	6KW, Ar-60, O2-28scm, 120KHz, 2.2us, 60mm T-W Space, 4-5mm T-M Space, 0-400W Bias

Figure 9

50 18245 US - w  
7/27

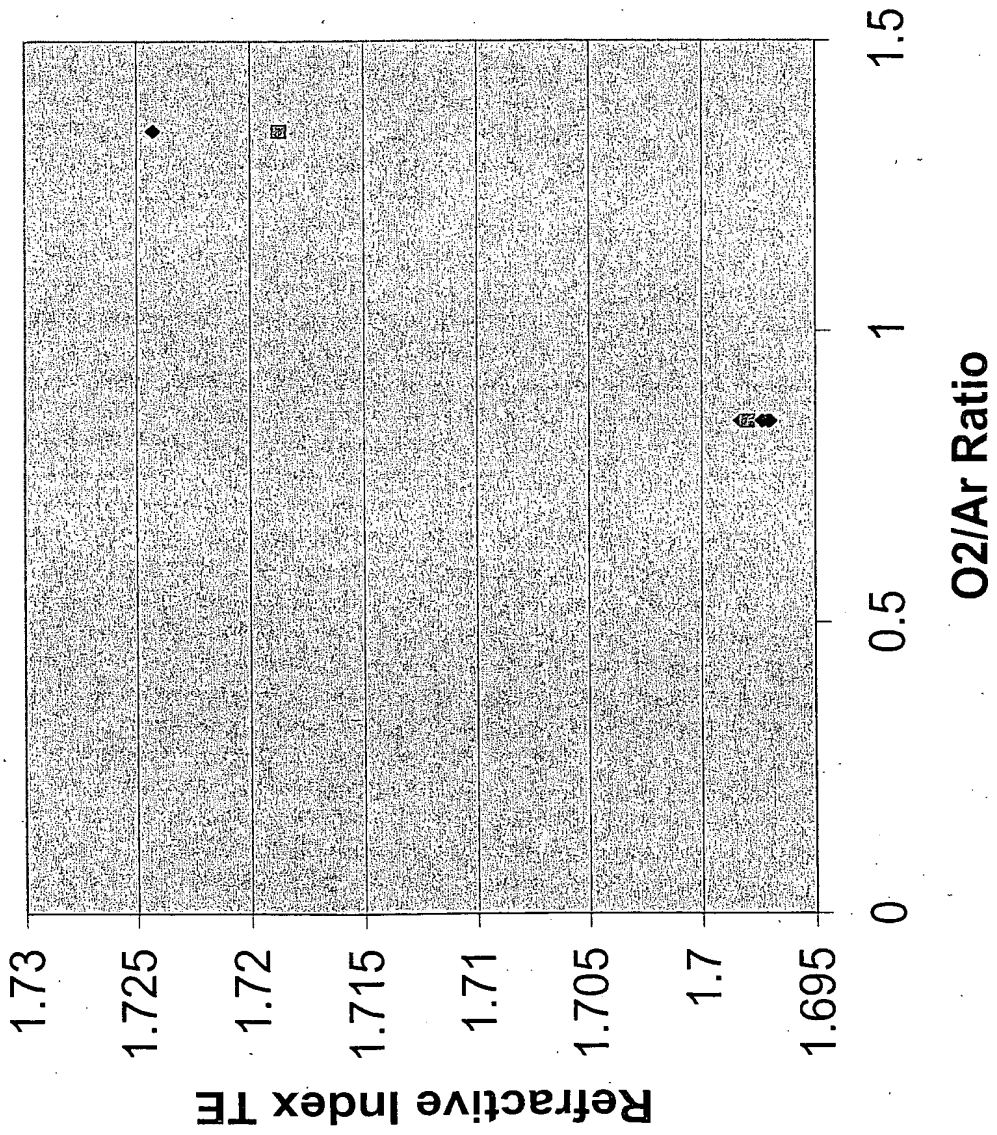
Bias Power (Watts)	DC Power (KW)	Pulsing Freq (KHz)	Reverse Time (μs)	Ar Flow (sccms)	O2 Flow (sccms)	Wafer Position	Target To Wafer Spacing (mm)	Refractive Index Avg (@1550nm)	Refractive Index STD (@1550nm)	Dep Rate (μm/Hr)
150	4.5	200	2.2	100	100	1	55	1.461508	0.000535	0.957654
150	4.5	200	2.2	100	100	2	55	1.462329	0.000376	0.962581
400	4.5	200	2.2	100	100	1	55	1.462774	0.000103	0.814007
400	4.5	200	2.2	100	100	2	55	1.463583	0.000095	0.824566

Figure 10

US-128801-018

2057E0" E98F0F0F

### R.I. vs O2/Ar Ratio



m-12845-05  
9/07

Figure II

### R.I. vs Pulsing Frequency for Alumina

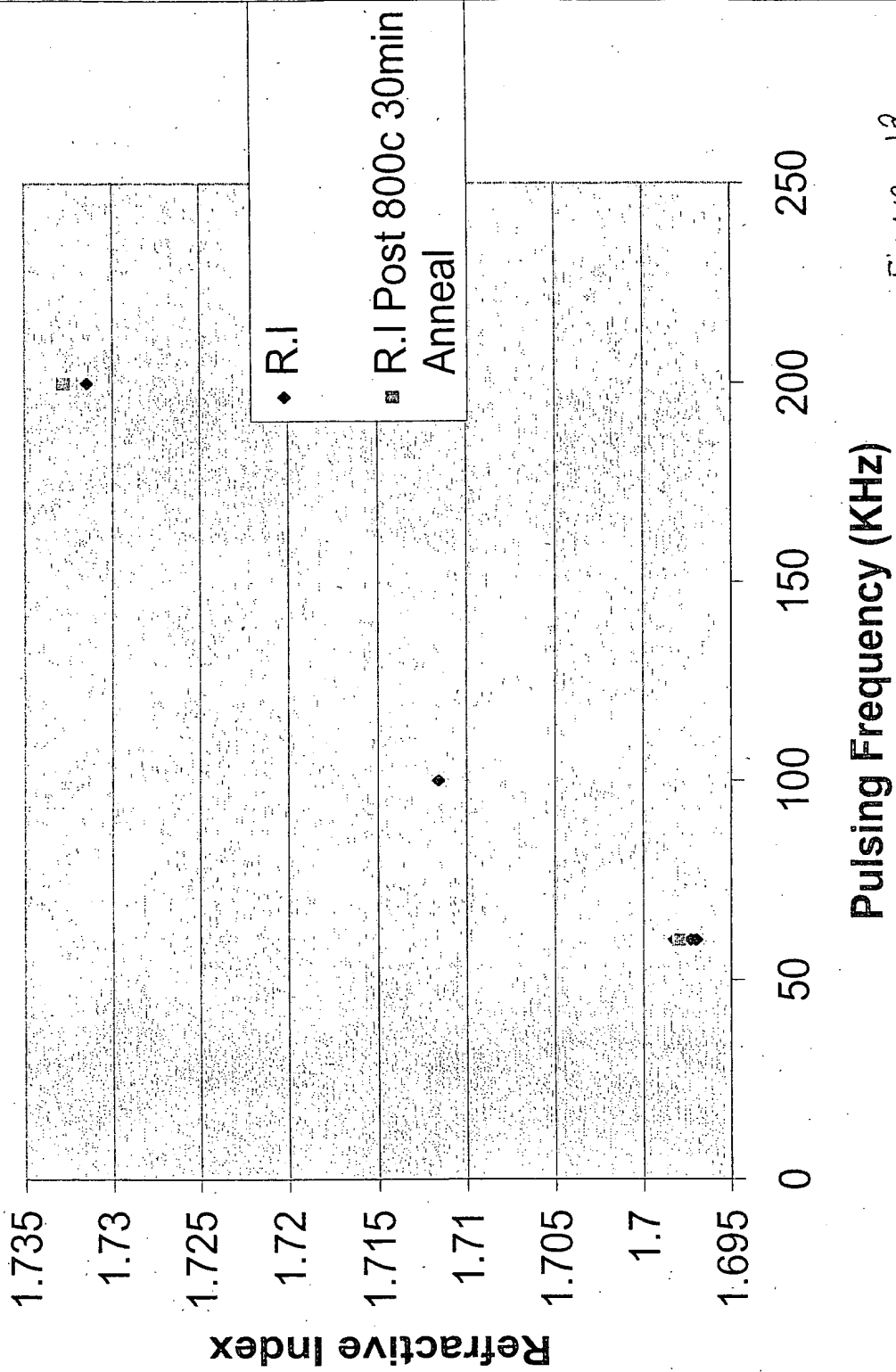


Figure 1a

10/27  
M-1245  
US

209F60-698F0F0F

Target 9A-8  
AET 4300 Base Reactor

### Index and Dep Rate Drifts Pre & Post Anneal

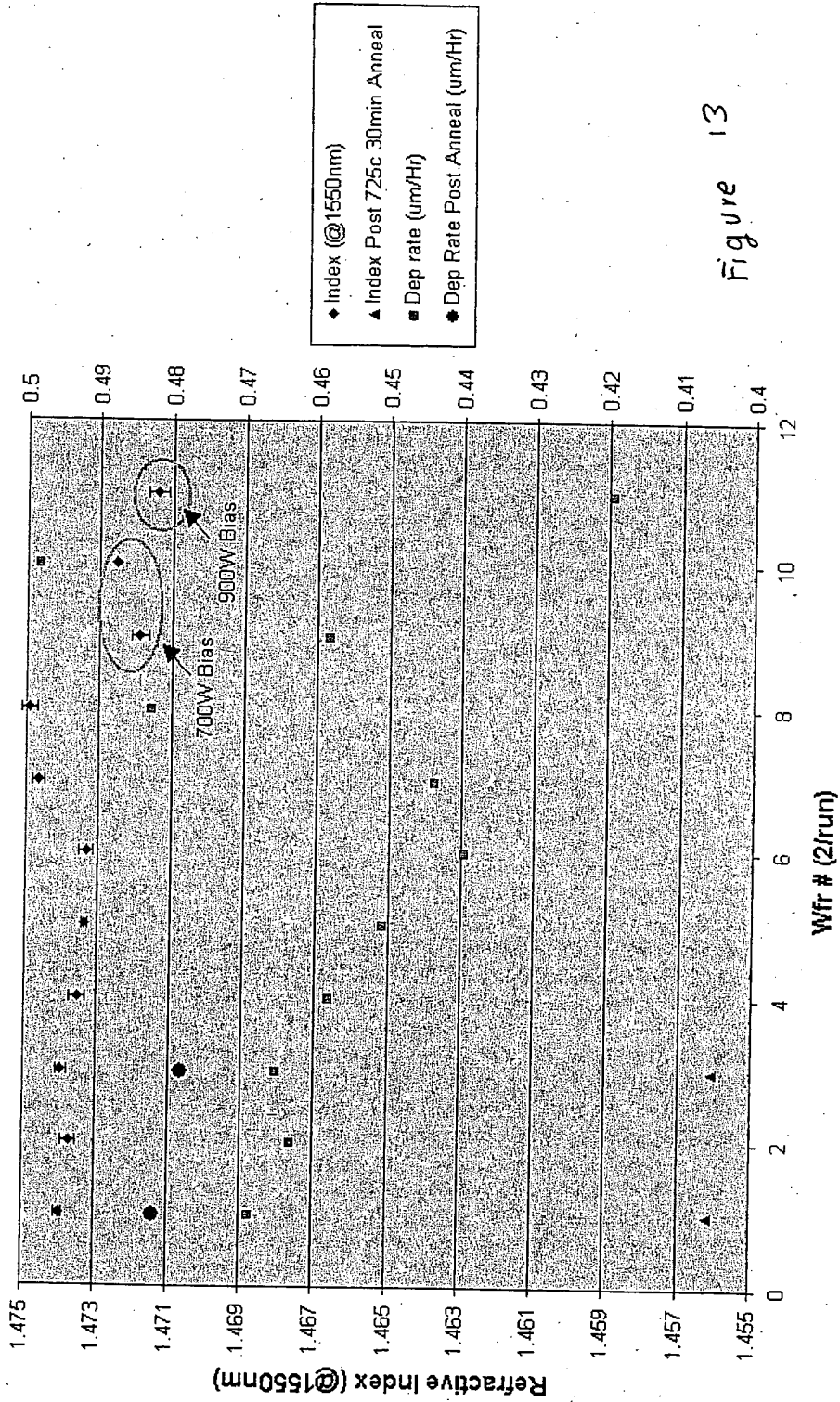


Figure 13

m-1245 us  
11/27

2057E0" ESBFOF01

### Index Drift Control Target 83-17 (AKT-1600 based reactor)

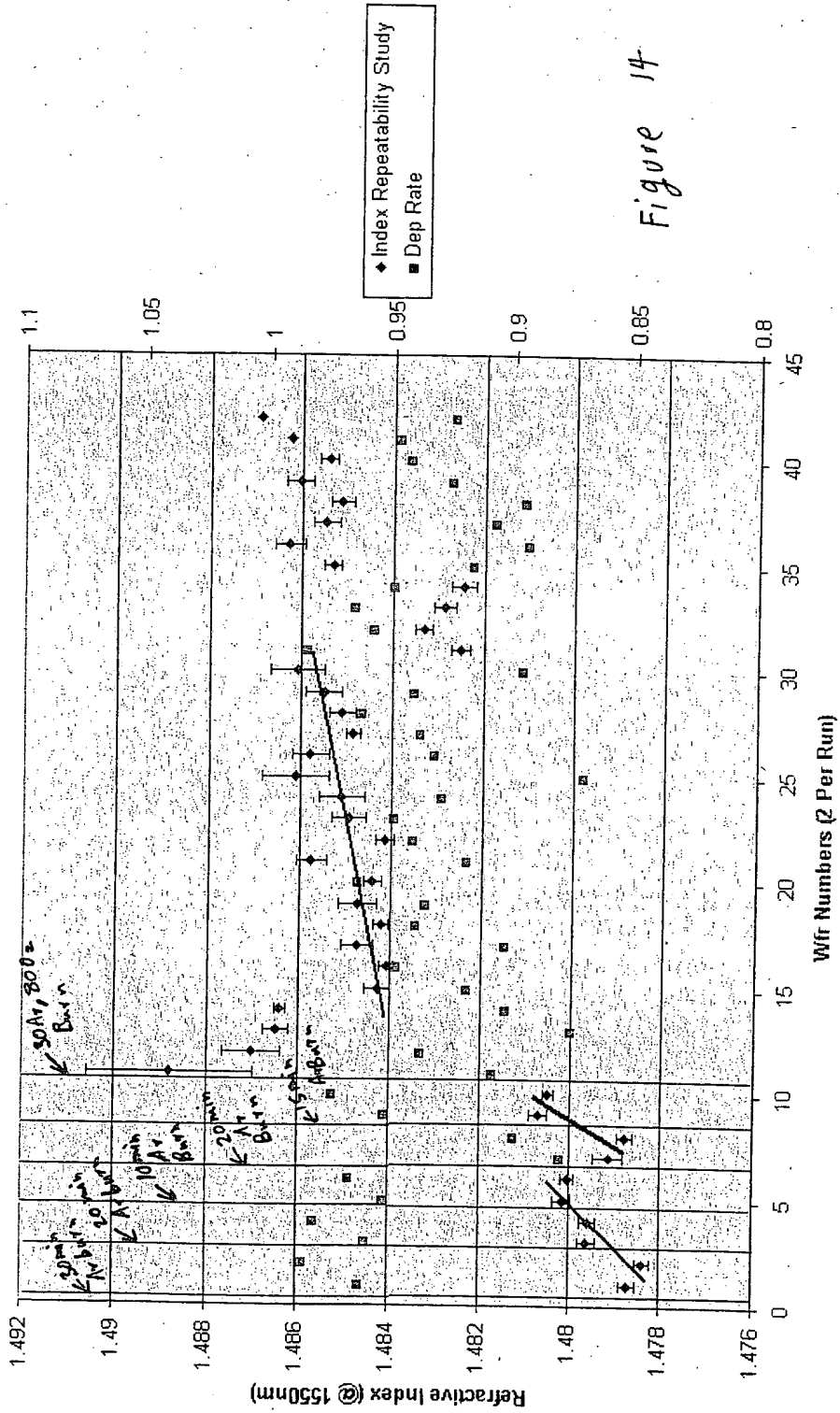


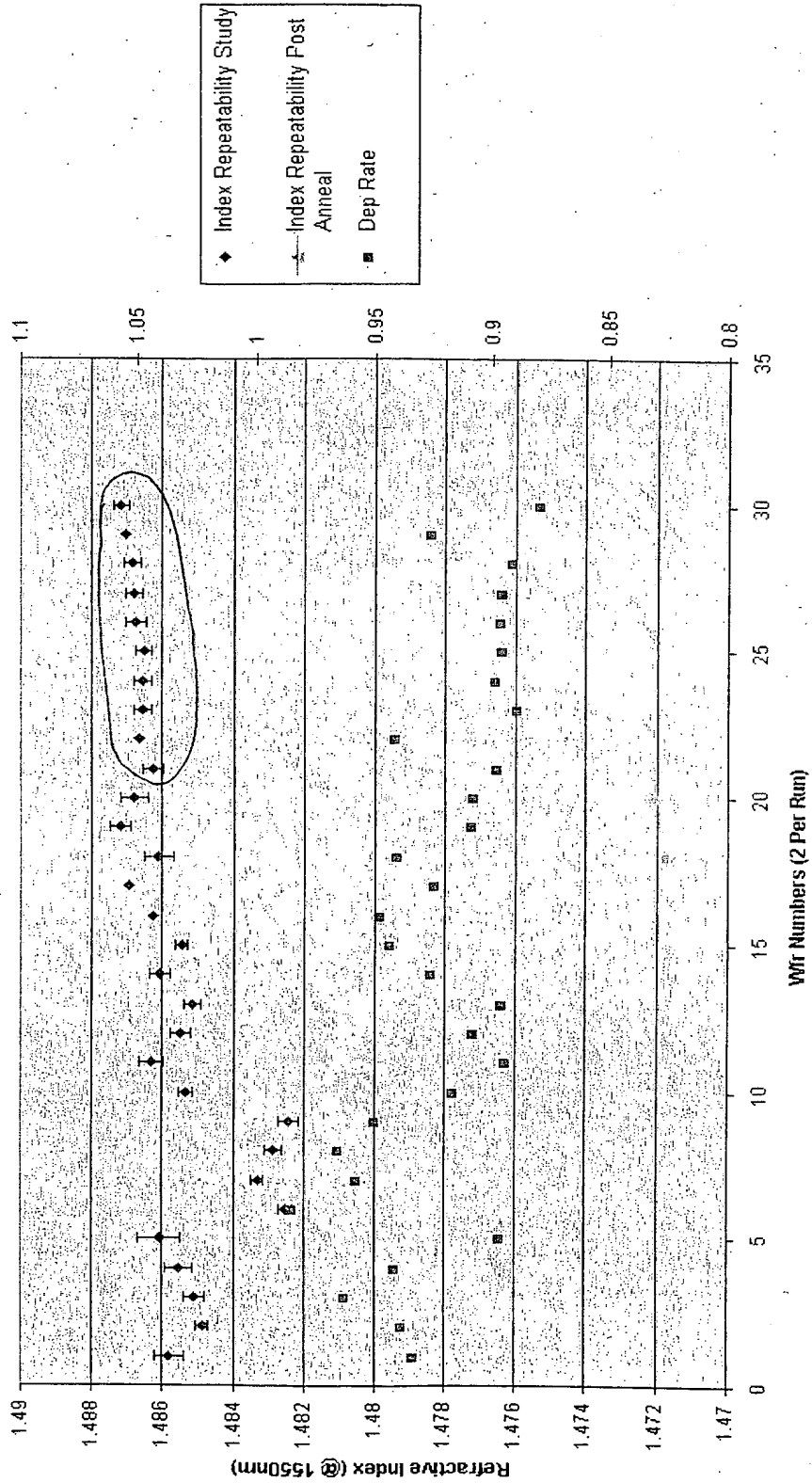
Figure 14

m-12245 US  
12/27

209750" ESRFF01

83-17 Target / AKT 1600 based reactor.

### Index Drift Control



M-18245 US  
13/27

Figure 15

M-12245 US  
14/27

209160 ES8F0F0F

1601

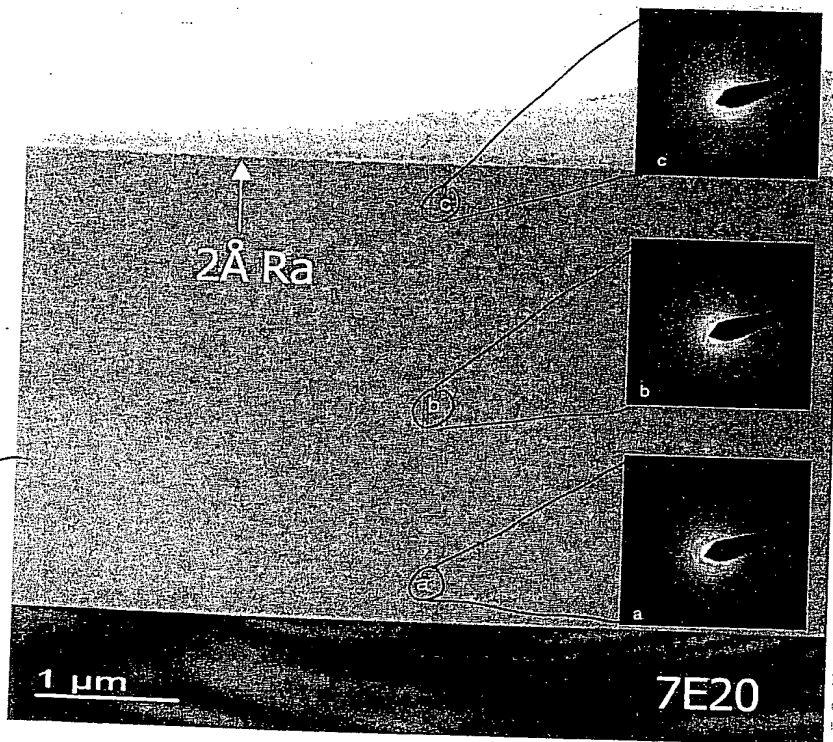


Figure 16 D

Figure 16 C

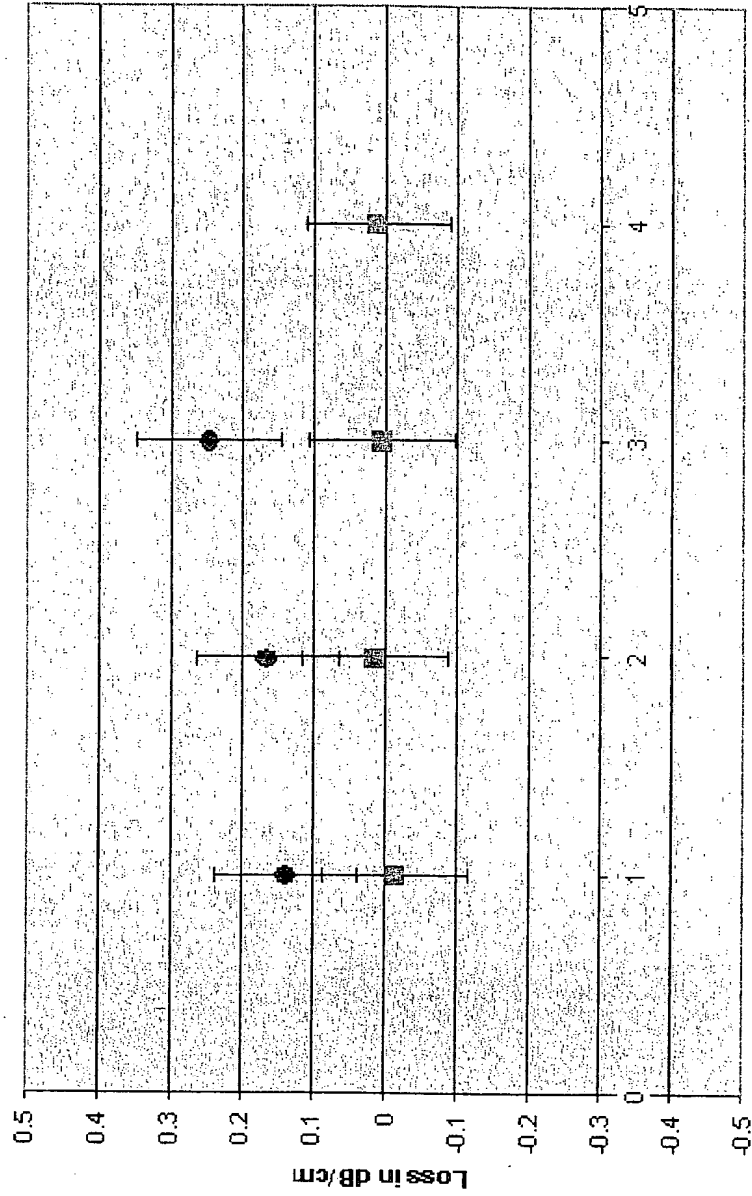
Figure 16 B

**Symmorphix PVD aluminosilicate**

Figure 16 A



2094E0" E3810101



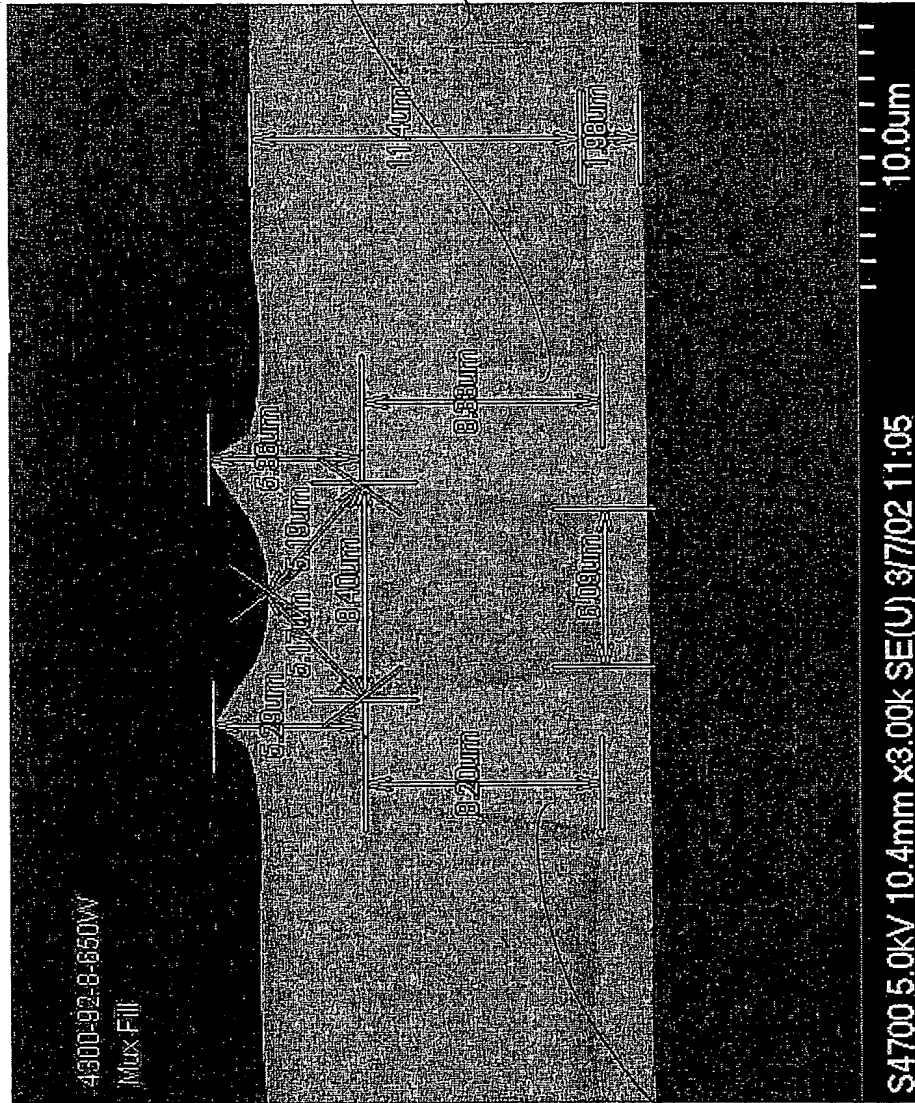
Path (cm)

◆ #8 - unannealed □ #7 - annealed

Figure 17

m - 18245 U5  
15/27

209FEQ-E9810101



m-1245 us  
16/91

Figure 18

M-12245 US  
17/27

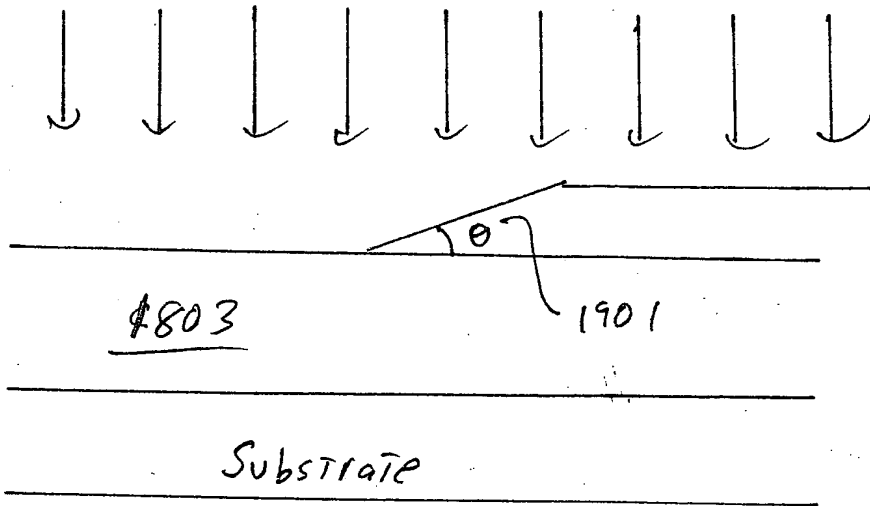


Figure 19

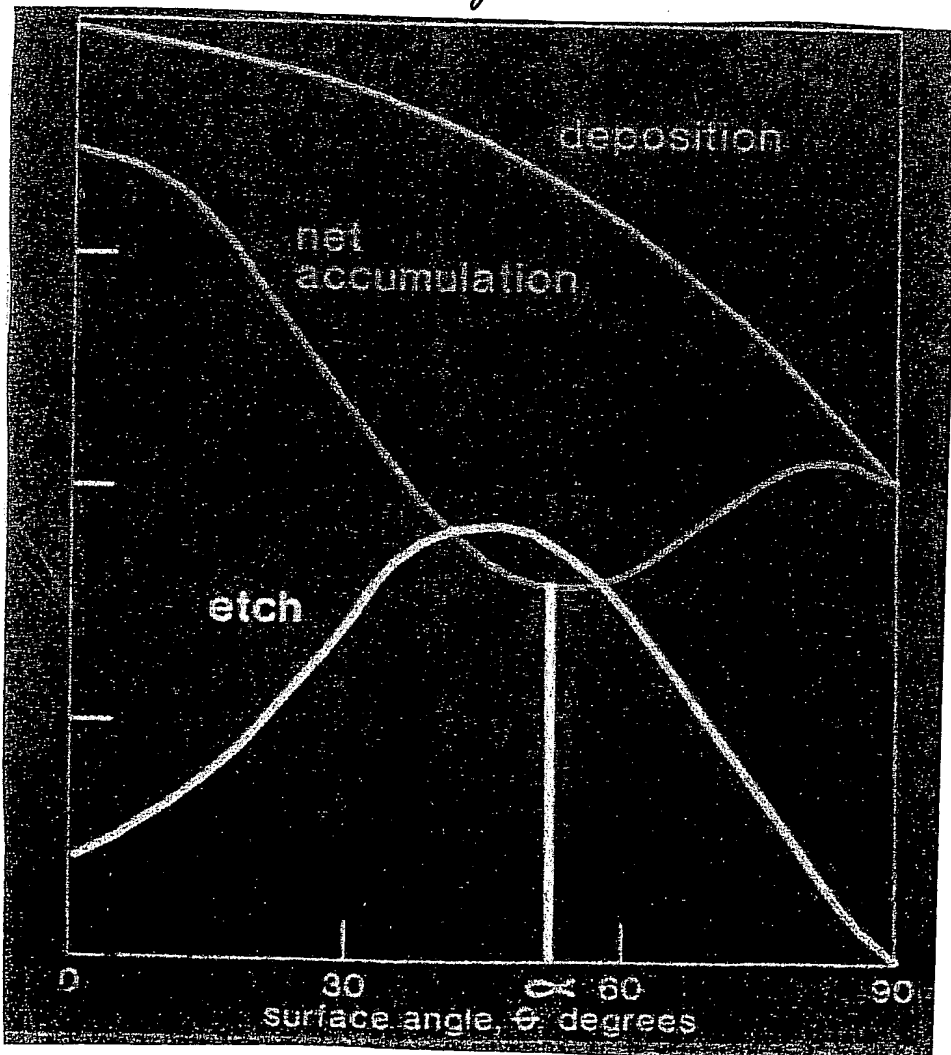


Figure 20

2091E0-ESB.FOF

m-12245 US  
18/27

10101863-031600

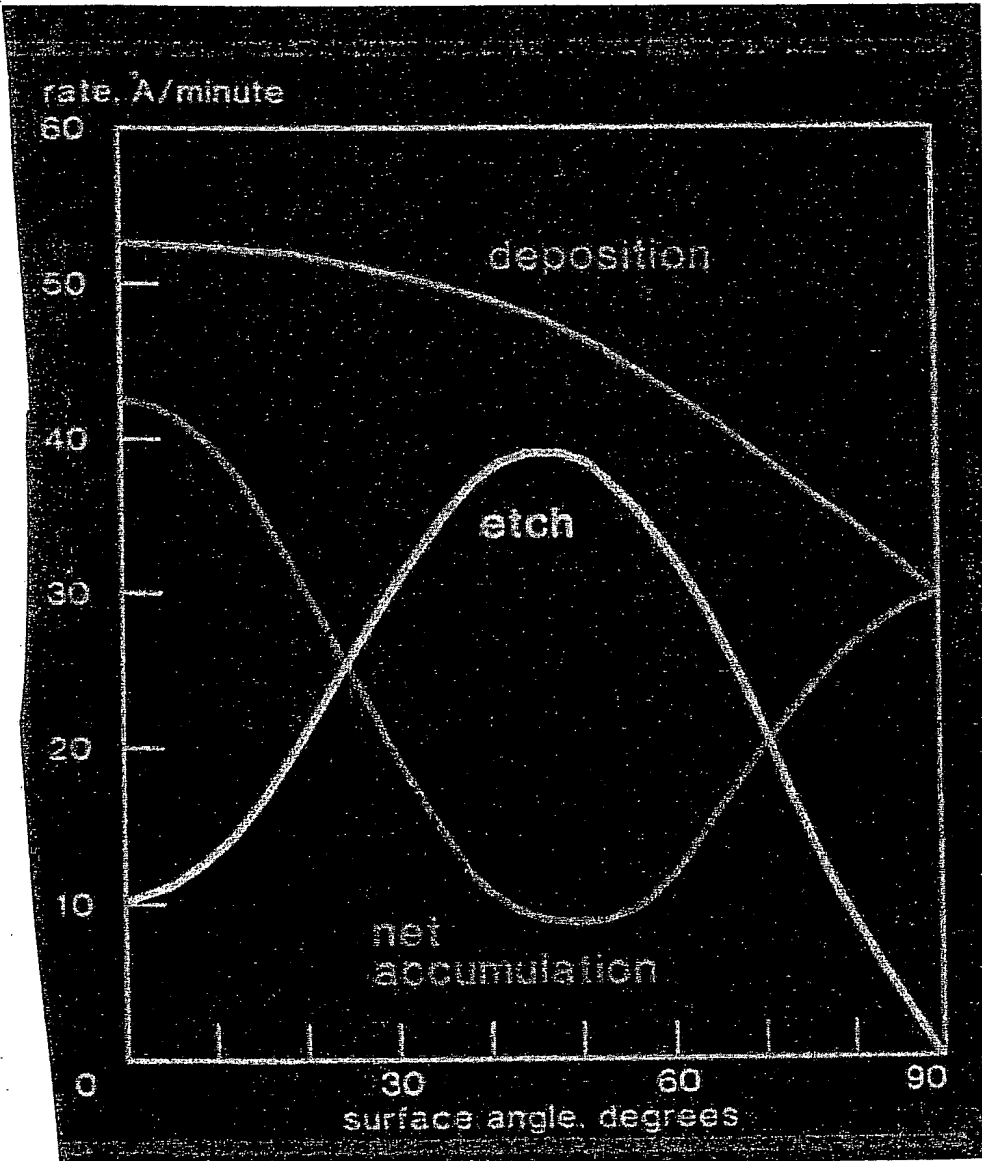


Figure 21

m-12245 US  
19/27

20570° E8810101

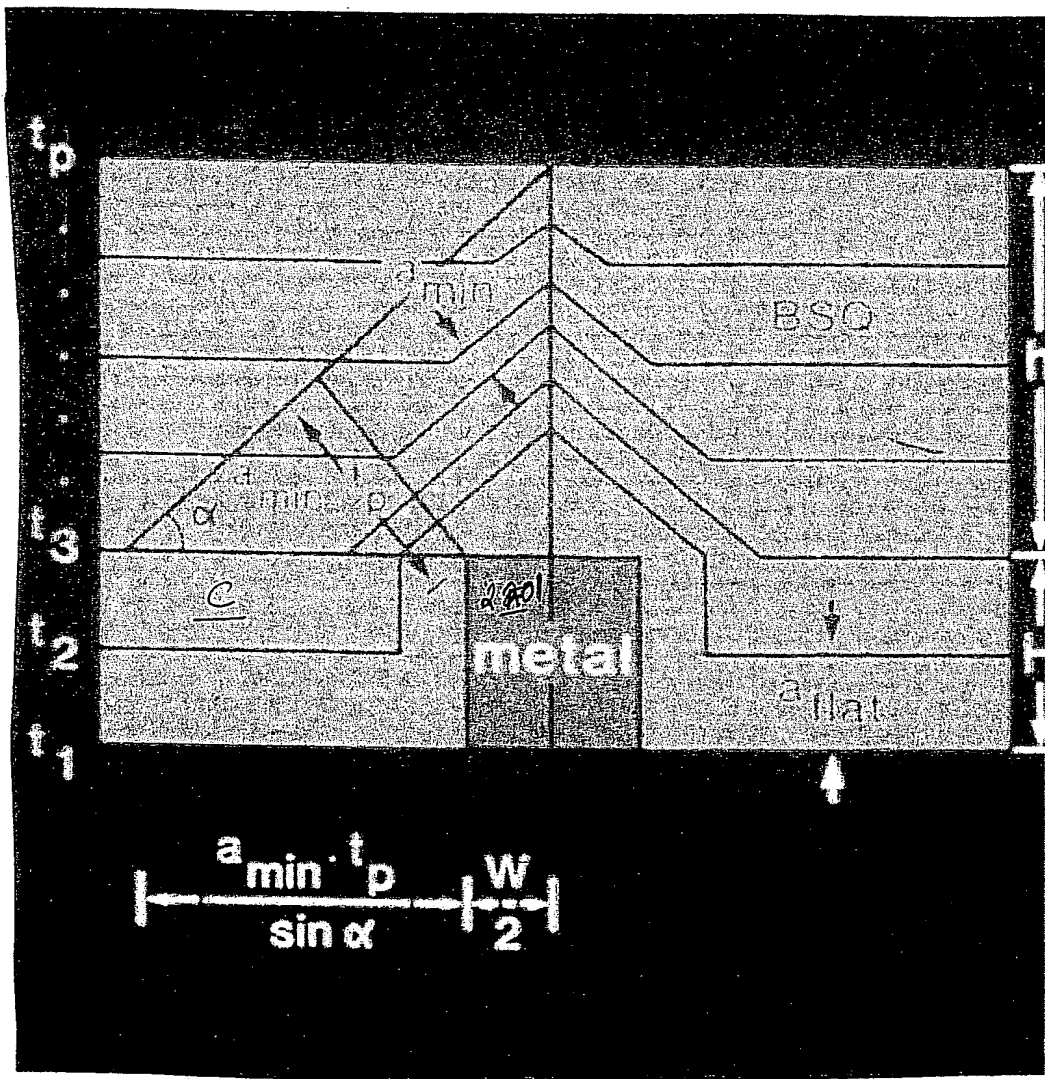


Figure 22

M-12 245 US  
20/27

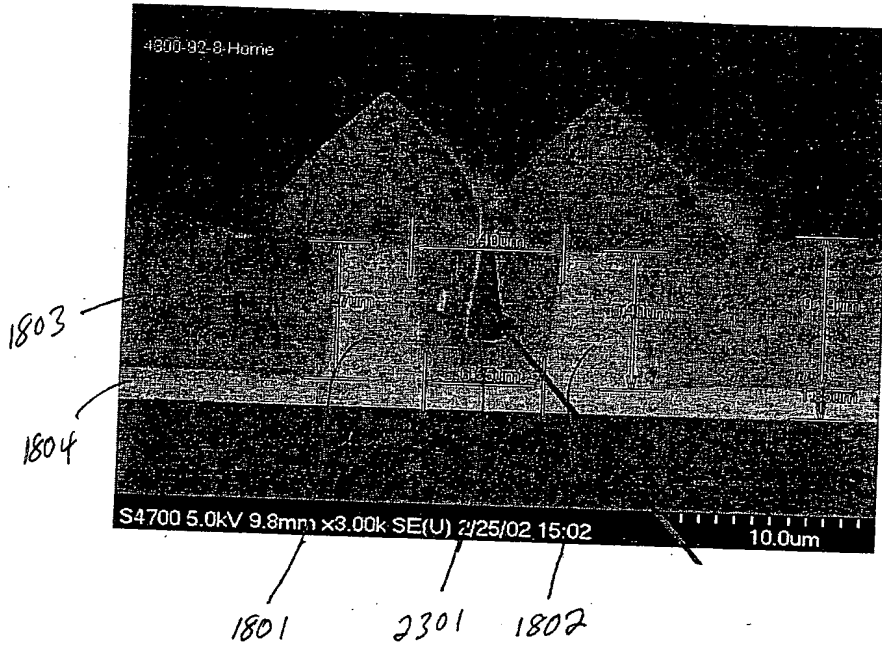
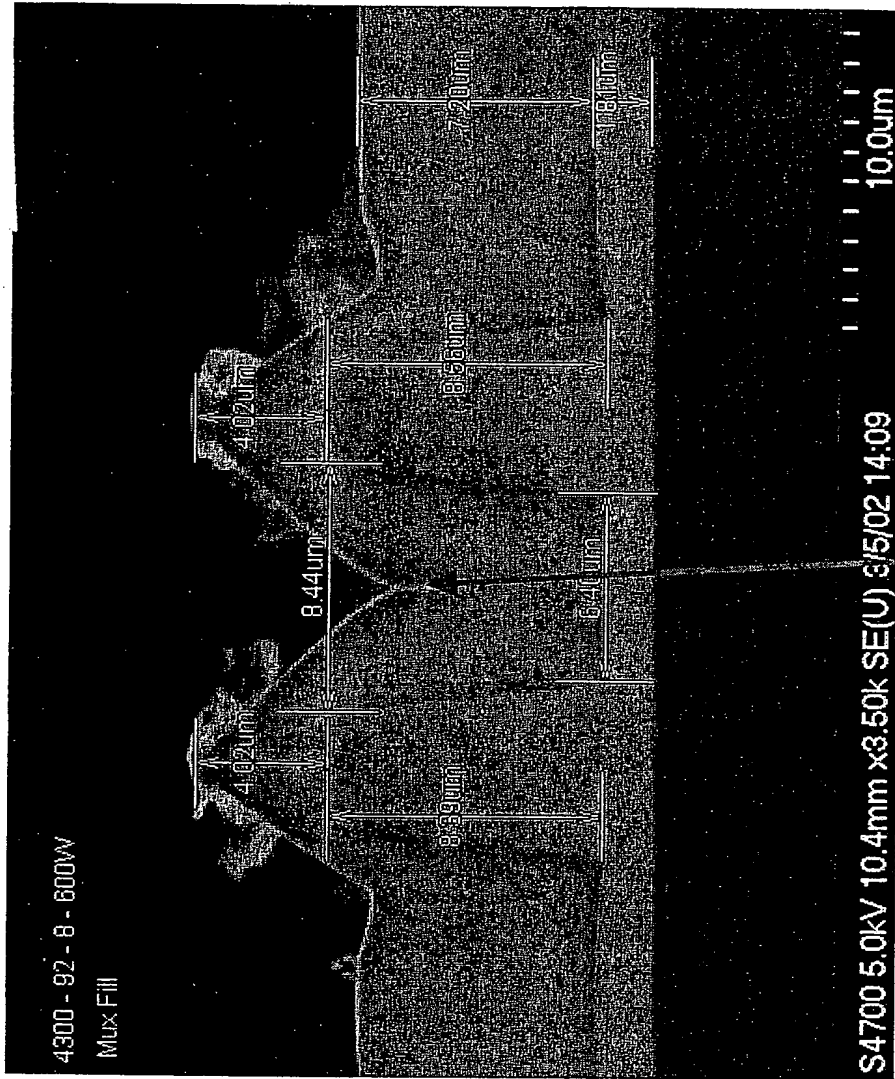


Figure 23

202503040101

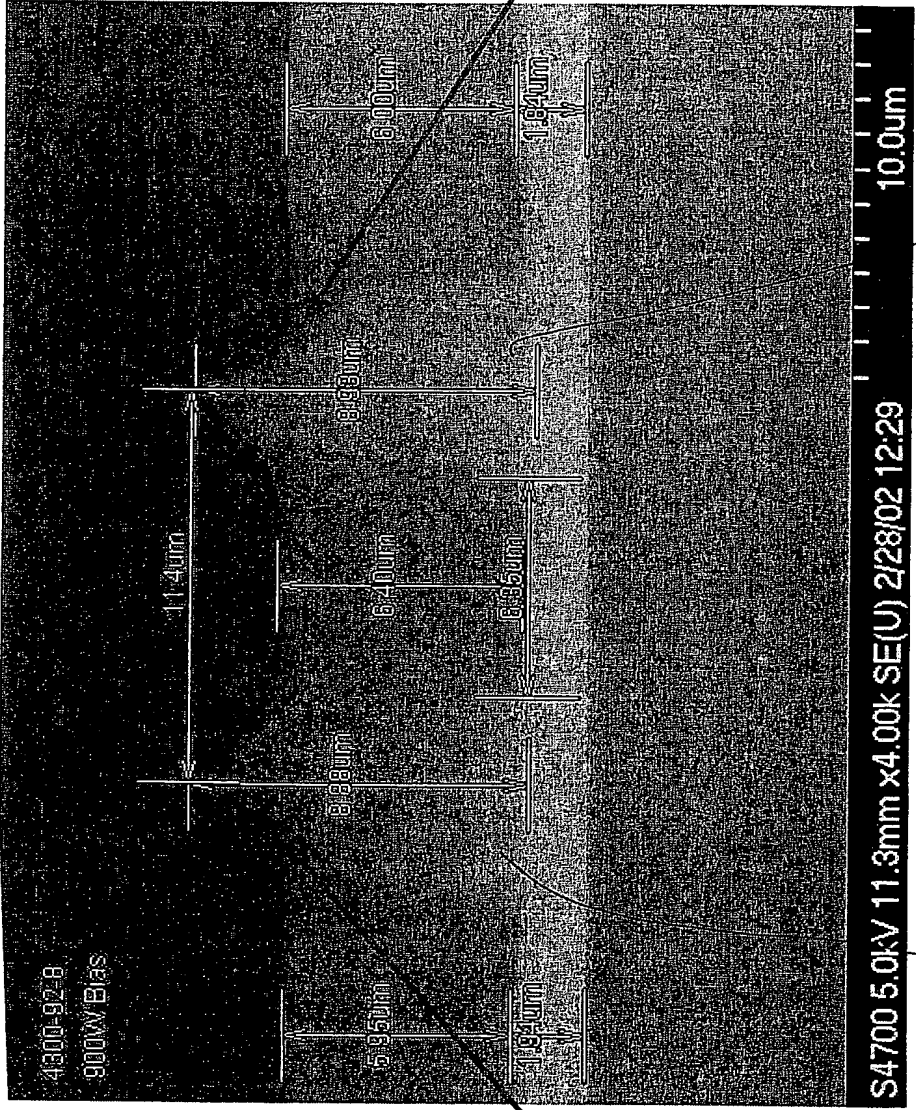
2097ED E88F0F0F



M-12845 US 2/1/02

Figure 24

209FE0-E98F0F0F



2058

1802

Figure 25

1801

2501

50 she el - W  
to/ee



m- 12245 US  
23/27

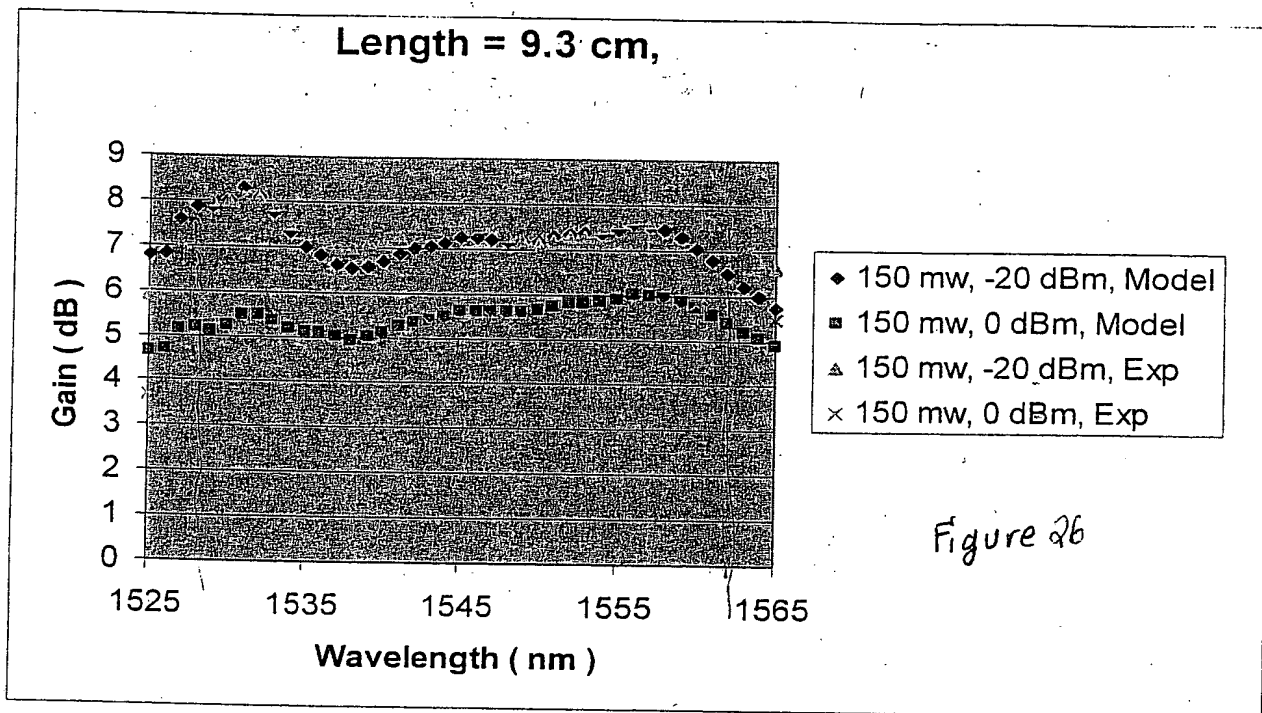


Figure 26

RESTRICTED

m- 12 245 US  
24/27

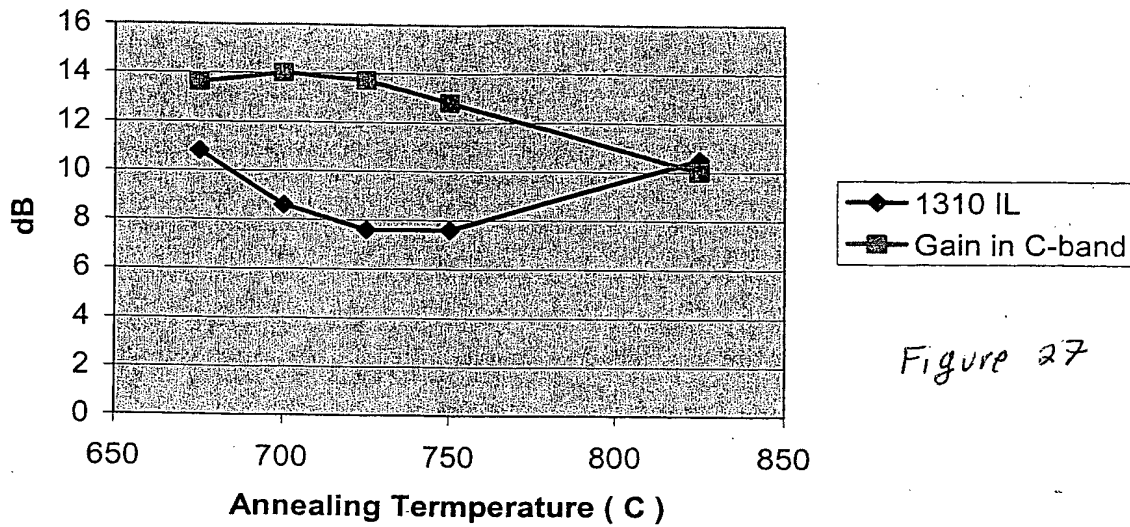
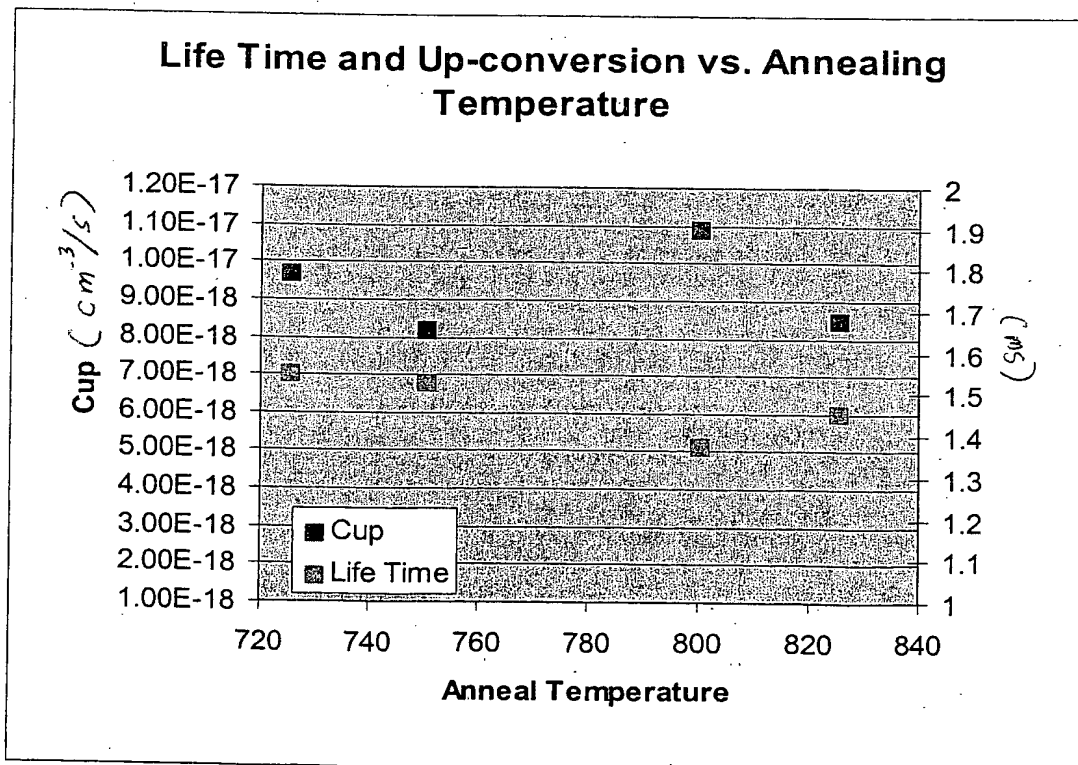


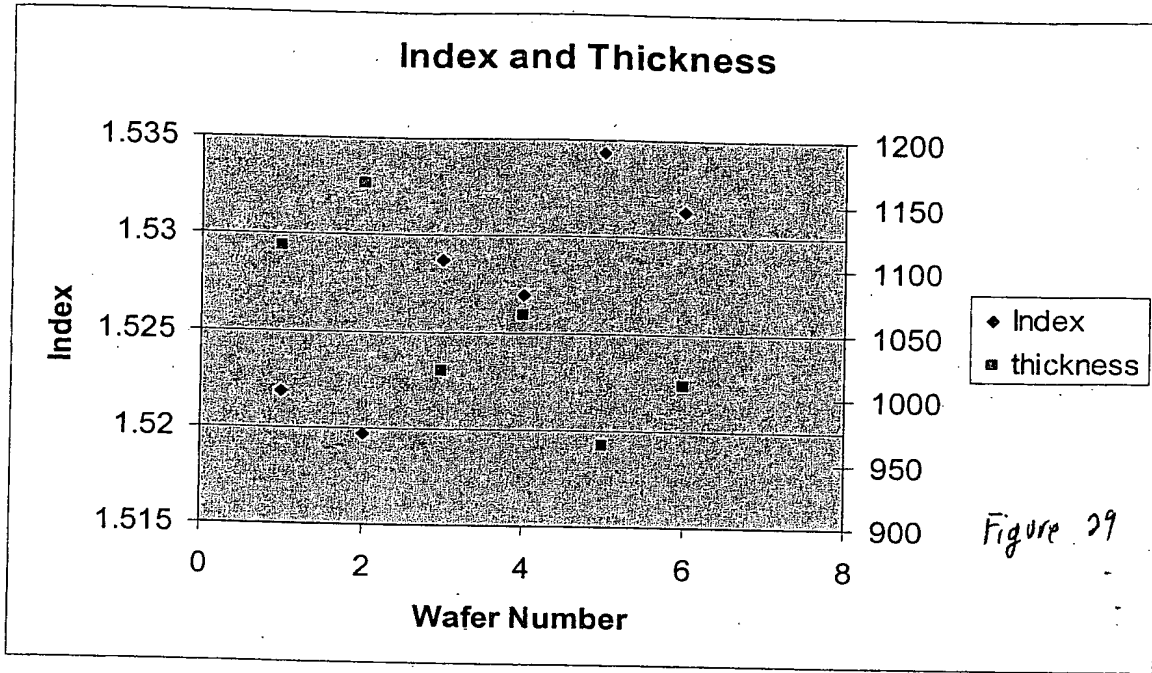
Figure 27

Figure 28

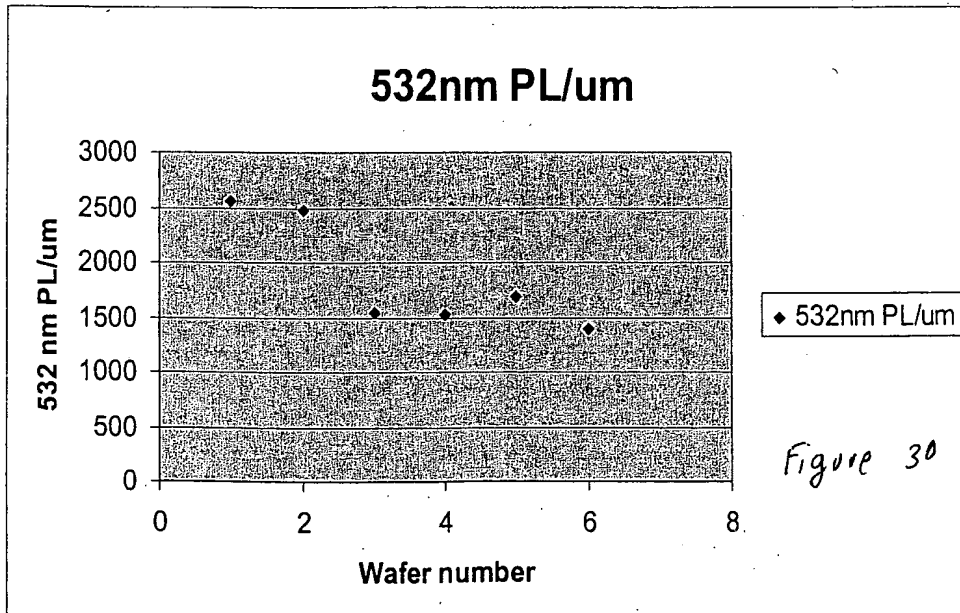


2025F01-98870701

M-12 245 US  
25/27



2097ED 99870707



m-12245 US  
26/27

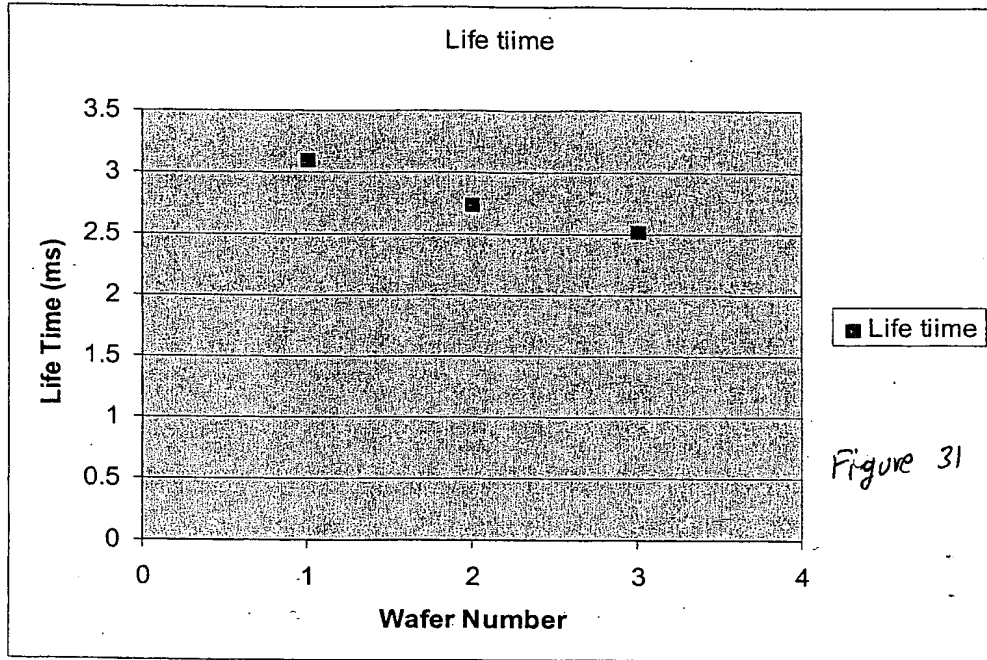


Figure 31

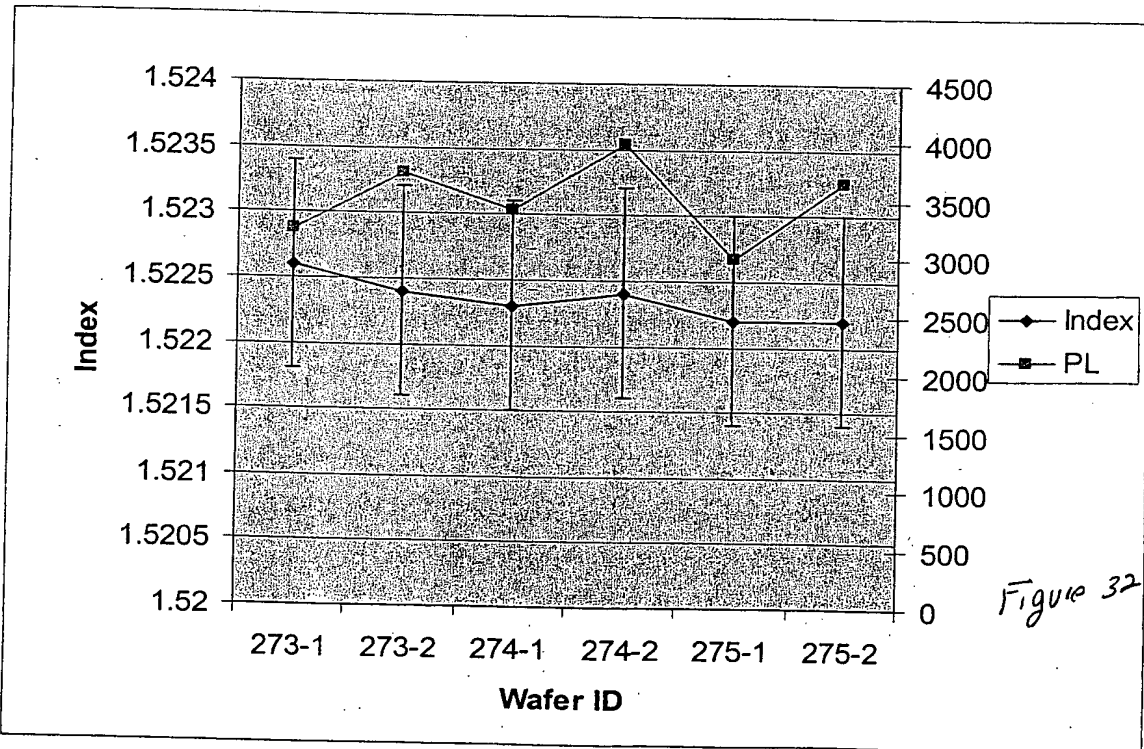
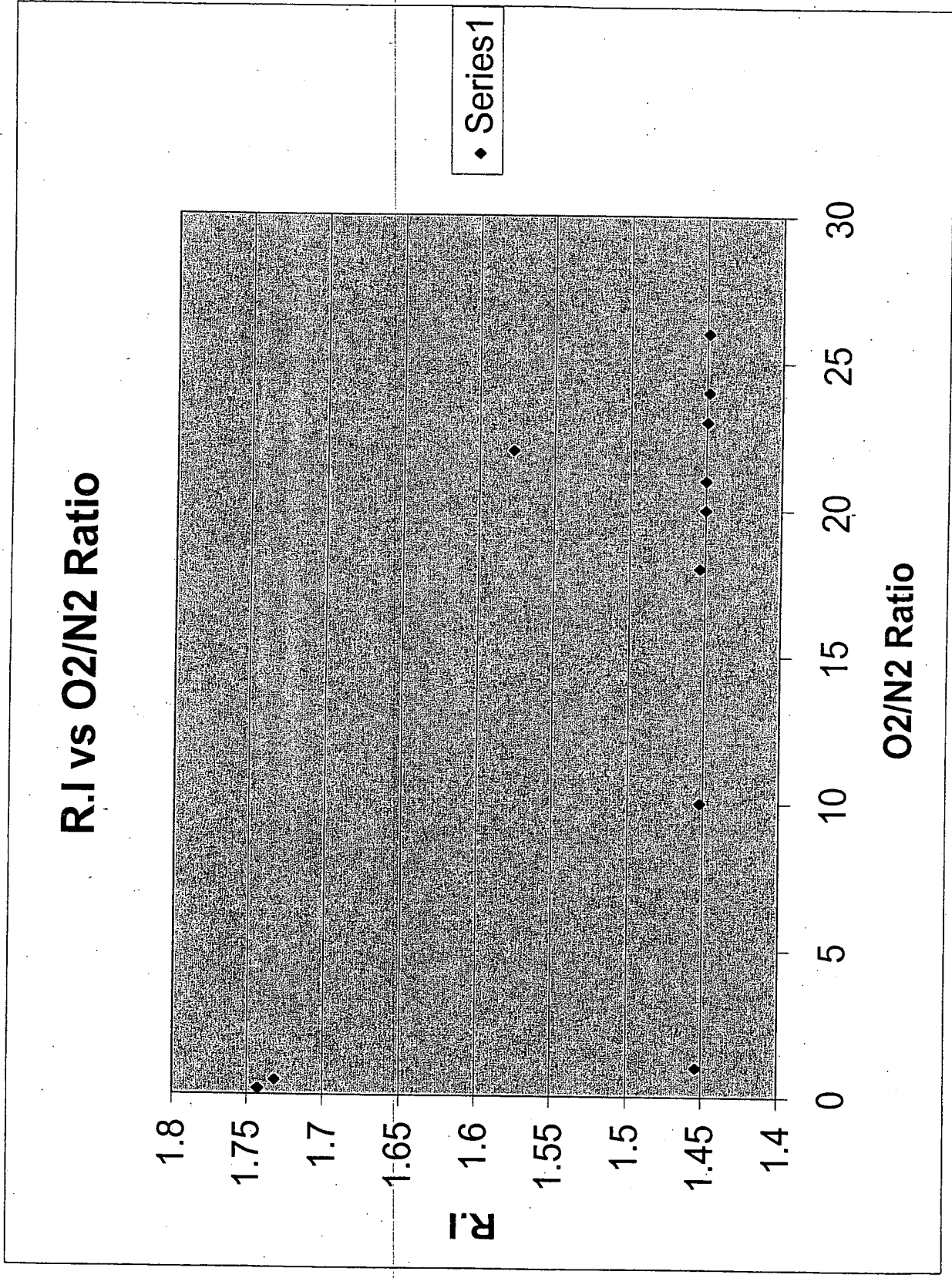


Figure 32

2097E0-ES8F0F0F

2091E0" E9BFOFOF



sp. sheet - w  
- 27/27

Figure 33

## Biased Pulse DC Reactive Sputtering of Oxide Films

Hongmei Zhang  
Mukundan Narasimhan  
Ravi Mullapudi  
Richard E. Demaray

### Background

#### 1. Field of the Invention

[0001] The present invention relates to deposition of oxide and oxynitride films and, in particular, to deposition of oxide and oxynitride films by pulsed DC reactive sputtering.

#### 2. Discussion of Related Art

[0002] Deposition of insulating materials and especially optical materials is technologically important in several areas including production of optical devices and production of semiconductor devices. In semiconductor devices, doped alumina silicates can be utilized as high dielectric insulators.

[0003] The increasing prevalence of fiber optic communications systems has created an unprecedented demand for devices for processing optical signals. Planar devices such as optical waveguides, couplers, splitters, and amplifiers, fabricated on planar substrates, like those commonly used for integrated circuits, and configured to receive and process signals from optical fibers are highly desirable. Such devices hold promise for integrated optical and electronic signal processing on a single semiconductor-like substance.

[0004] The basic design of planar optical waveguides and amplifiers is well known, as described, for example, in U. S. Patent Nos. 5,119,460 and 5,563,979 to Bruce et al., 5,613,995 to Bhandarkar et al., 5,900,057 to Buchal et al., and 5,107,538 to Benton et al., to cite only a few. These devices, very generally, include a core region, typically bar shaped, of a certain refractive index surrounded by a cladding region of a lower refractive index. In the case of an optical amplifier, the core region includes a certain concentration of a dopant, typically a rare earth ion

such as an erbium or praseodymium ion which, when pumped by a laser, fluoresces, for example, in the 1550 nm and 1300 nm wavelength ranges used for optical communication, to amplify the optical signal passing through the core.

[0005] As described, for example in the patents by Bruce et al., Bhandarkar et al, and Buchal et al., planar optical devices may be fabricated by process sequences including forming a layer of cladding material on a substrate; forming a layer of core material on the layer of cladding mater; patterning the core layer using a photolithographic mask and an etching process to form a core ridge; and covering the core ridge with an upper cladding layer.

[0006] The performance of these planar optical devices depends sensitively on the value and uniformity of the refractive index of the core region and of the cladding region, and particularly on the difference in refractive index,  $\Delta n$ , between the regions. Particularly for passive devices such as waveguides, couplers, and splitters,  $\Delta n$  should be carefully controlled, for example to values within about 1 %, and the refractive index of both core and cladding need to be highly uniform, for some applications at the fewer than parts per thousand level. In the case of doped materials forming the core region of planar optical amplifiers, it is important that the dopant be uniformly distributed so as to avoid non-radiative quenching or radiative quenching, for example by upconversion. The refractive index and other desirable properties of the core and cladding regions, such as physical and chemical uniformity, low stress, and high density, depend, of course, on the choice of materials for the devices and on the processes by which they are fabricated.

[0007] Because of their optical properties, silica and refractory oxides such as  $Al_2O_3$ , are good candidate materials for planar optical devices. Further, these oxides serve as suitable hosts for rare earth dopants used in optical amplifiers. A common material choice is so-called low temperature glasses, doped with alkali metals, boron, or phosphorous, which have the advantage of requiring lower processing temperatures. In addition, dopants are used to modify the refractive index. Methods such as flame hydrolysis, ion exchange for introducing alkali ions in glasses, sputtering, and various chemical vapor deposition processes (CVD) have been used to form films of doped glasses. However, dopants such as phosphorous and boron are hygroscopic, and alkalis are undesirable for integration with electronic devices. Control of uniformity of doping in CVD processes can be difficult and CVD deposited films can have structural defects

leading to scattering losses when used to guide light. In addition, doped low temperature glasses may require further processing after deposition. A method for eliminating bubbles in thin films of sodium-boro-silicate glass by high temperature sintering is described, for example, in the '995 patent to Bhandarkar et al.

[0008] Typically, RF sputtering has been utilized for deposition of oxide dielectric films. However, RF sputtering utilizes ceramic targets which are typically formed of multiple smaller tiles. Since the tiles can not be made very large, there may be a large problem of arcing between tiles and therefore contamination of the deposited film due to this arcing. Further, the reactors required for RF sputtering tend to be rather complicated. In particular, the engineering of low capacitance efficient RF power distribution to the cathode is difficult in RF systems. Routing of low capacitance forward and return power into a vacuum vessel of the reaction chamber often exposes the power path in such a way that diffuse plasma discharge is allowed under some conditions of impedance tuning of the matching networks.

[0009] Therefore, there is a need for new methods of depositing oxide and oxynitride films and for forming planar optical devices.

### Summary

[0010] In accordance with the present invention, a sputtering reactor apparatus for depositing oxide and oxynitride films is presented. Further, methods for depositing oxide and oxynitride films for optical waveguide devices are also presented. A sputtering reactor according to the present invention includes a pulsed DC power supply coupled through a filter to a target and a substrate electrode coupled to an RF power supply. A substrate mounted on the substrate electrode is therefore supplied with a bias from the RF power supply.

[0011] The target can be a metallic target made of a material to be deposited on the substrate. In some embodiments, the metallic target is formed from Al, Si and various rare-earth ions. A target with an erbium concentration, for example, can be utilized to deposit a film that can be formed into a waveguide optical amplifier.

[0012] A substrate can be any material and, in some embodiments, is a silicon wafer. In some



embodiments, RF power can be supplied to the wafer. In some embodiments, the wafer and the electrode can be separated by an insulating glass.

[0013] In some embodiments, up to about 10 kW of pulsed DC power at a frequency of between about 40 kHz and 350 kHz and a reverse pulse time of up to about 5  $\mu$ s is supplied to the target. The wafer can be biased with up to about several hundred watts of RF power. The temperature of the substrate can be controlled to within about 10° C and can vary from about -50° C to several hundred degrees C. Process gasses can be fed into the reaction chamber of the reactor apparatus. In some embodiments, the process gasses can include combinations of Ar, N<sub>2</sub>, O<sub>2</sub>, C<sub>2</sub>F<sub>6</sub>, CO<sub>2</sub>, CO and other process gasses.

[0014] Several material properties of the deposited layer can be modified by adjusting the composition of the target, the composition and flow rate of the process gasses, the power supplied to the target and the substrate, and the temperature of the substrate. For example, the index of refraction of the deposited layer depends on deposition parameters. Further, in some embodiments stress can be relieved on the substrate by depositing a thin film of material on a back side of the wafer. Films deposited according to the present invention can be utilized to form optical waveguide devices such as multiplexers and rare-earth doped amplifiers.

[0015] These and other embodiments, along with examples of material layers deposited according to the present invention, are further described below with respect to the following figures.

#### **Brief Description of the Figures**

[0016] Figures 1A and 1B show a pulsed DC sputtering reactor according to the present invention.

[0017] Figure 2 shows a planar view of target utilized in a reactor as shown in Figures 1A and 1B.

[0018] Figure 3 shows a cross-section view of an example target utilized in a reactor as shown in Figures 1A and 1B.

[0019] Figure 4 shows a flow chart of an embodiment of a process for depositing a film on a substrate according to the present invention.

[0020] Figure 5 shows a hysteresis curve of target voltage versus oxygen flow rates for an example target in an embodiment of a reactor according to the present invention.

[0021] Figure 6 shows a photo-luminescence and lifetimes of a film deposited in a process according to the present invention as a function of after deposition anneal temperature.

[0022] Figure 7 shows the relationship between the index of refraction of a film as a function of deposited oxide layers according to the present invention and due to oxide build-up on the target.

[0023] Figure 8 shows a graph of the index of refraction of a film deposited according to the present invention as a function of the aluminum content in a composite Al/Si target.

[0024] Figure 9 shows a graph of typical indices of refraction of material layers deposited according to the present invention.

[0025] Figure 10 shows a table of indices of refraction for a silica layer deposited according to the present invention as a function of different process parameters.

[0026] Figure 11 shows the refractive indices as a function of O<sub>2</sub>/Ar ratio utilized in an Alumina process according to the present invention.

[0027] Figure 12 shows the refractive indices as a function of DC pulsed power frequency for an Alumina layer deposited according to the present invention.

[0028] Figure 13 shows variation in the refractive index over time during repeated depositions from a single target.

[0029] Figure 14 shows variation in refractive index over time for repeated depositions from a target of another material layer according to the present invention.

[0030] Figure 15 shows the variation refractive index over time for repeated depositions from a target of another material layer according to the present invention.

[0031] Figure 16A through 16D shows a TEM film deposited according to the present invention.

[0032] Figure 17 shows the transparency of a film deposited according to the present invention.

[0033] Figure 18 shows an uppercladding layer deposited according to the present invention over a multiple-waveguide structure such that the deposited layer is substantially planarized.

[0034] Figure 19 illustrates the deposition of a film over a waveguide structure.

[0035] Figures 20 and 21 illustrate different etch and deposition rates for deposition of films as a function of the surface angle of the film.

[0036] Figure 22 illustrates calculation of the planarization time for a particular deposition process.

[0037] Figures 23 through 25 through illustrate adjustment of process parameters in order to achieve planarization of a film deposited over a waveguide structure according to the present invention.

[0038] Figure 26 shows the gain characteristics of an erbium doped waveguide amplifier formed of films depositions according to the present invention.

[0039] Figures 27 shows gain, insertion loss of a waveguide with an active core deposited according to the present invention.

[0040] Figure 28 shows up-conversion constants, and lifetimes of the active core layer of Figure 27 deposited according to the present invention.

[0041] Figure 29 shows drift in the index of refraction with subsequent depositions for films deposited from a target according to the present invention.

[0042] Figure 30 shows drift in the photoluminescence with subsequent depositions according to the present invention.

[0043] Figure 31 shows drift in the excited state lifetime with subsequent depositions according to the present invention.

[0044] Figure 32 shows stabilization of the index of refraction in subsequent depositions.

[0045] Figure 33 shows the index of refraction of a film formed from a pure silicon target as a

function of the ratio of  $O_2/N_2$  in the process gas.

[0046] In the figures, elements having the same designation have the same or similar function.

### Detailed Description

[0047] Reactive DC magnetron sputtering of nitrides and carbides is a widely practiced technique, but the reactive dc magnetron sputtering of nonconducting oxides is done rarely. Films such as aluminum oxide are almost impossible to deposit by conventional reactive DC magnetron sputtering due to rapid formation of insulating oxide layers on the target surface. The insulating surfaces charges up and result in arcing during process. This arcing can damage the power supply, produce particles and degrade the properties of deposited oxide films.

[0048] RF sputtering of oxide films is discussed in Application Serial No. 09/903,050 (the '050 application) by Demaray et al., entitled "Planar Optical Devices and Methods for Their Manufacture," assigned to the same assignee as is the present invention, herein incorporated by reference in its entirety. Further, targets that can be utilized in a reactor according to the present invention are discussed in U.S. Application serial no. {Attorney Docket No. M-12247 US} (the '247 application), filed concurrently with the present disclosure, assigned to the same assignee as is the present invention, herein incorporated by reference in its entirety. A gain-flattened amplifier formed of films deposited according to the present invention are described in U.S. Application serial no. {Attorney Docket No. M-12652 US} (the '652 application), filed concurrently with the present disclosure, assigned to the same assignee as is the present invention, herein incorporated by reference in its entirety. Further, a mode size converter formed with films deposited according to the present invention is described in U.S. Application serial no. {Attorney Docket No. M-12138 US} (the '138 application), filed concurrently with the present disclosure, assigned to the same assignee as is the present invention, herein incorporated by reference in its entirety.

[0049] Figure 1A shows a schematic of a reactor apparatus 10 for sputtering of material from a target 12 according to the present invention. In some embodiments, apparatus 10 may, for

example, be adapted from an AKT-1600 PVD (400 X 500 mm substrate size) system from Applied Komatsu or an AKT-4300 (600 X 720 mm substrate size) system from Applied Komatsu, Santa Clara, CA. The AKT-1600 reactor, for example, has three deposition chambers connected by a vacuum transport chamber. These Komatsu reactors can be modified such that pulsed DC power is supplied to the target and RF power is supplied to the substrate during deposition of a material film.

[0050] Apparatus 10 includes a target 12 which is electrically coupled through a filter 15 to a pulsed DC power supply 14. In some embodiments, target 12 is a wide area sputter source target, which provides material to be deposited on substrate 16. Substrate 16 is positioned parallel to and opposite target 12. Target 12 functions as a cathode when power is applied to it and is equivalently termed a cathode. Application of power to target 12 creates a plasma 53. Substrate 16 is capacitively coupled to an electrode 17 through an insulator 54. Electrode 17 can be coupled to an RF power supply 18. Magnet 20 is scanned across the top of target 12.

[0051] For pulsed reactive dc magnetron sputtering, as performed by apparatus 10, the polarity of the power supplied to target 12 by power supply 14 oscillates between negative and positive potentials. During the positive period, the insulating layer on the surface of target 12 is discharged and arcing is prevented. To obtain arc free deposition, the pulsing frequency exceeds a critical frequency that depend on target material, cathode current and reverse time. High quality oxide films can be made using reactive pulse DC magnetron sputtering in apparatus 10.

[0052] Pulsed DC power supply 14 can be any pulsed DC power supply, for example an AE Pinnacle plus 10K by Advanced Energy, Inc. With this example supply, up to 10 kW of pulsed DC power can be supplied at a frequency of between 0 and 350 KHz. The reverse voltage is 10% of the negative target voltage. Utilization of other power supplies will lead to different power characteristics, frequency characteristics and reverse voltage percentages. The reverse time on this embodiment of power supply 14 can be adjusted between 0 and 5  $\mu$ s.

[0053] Filter 15 prevents the bias power from power supply 18 from coupling into pulsed DC power supply 14. In some embodiments, power supply 18 is a 2 MHz RF power supply, for example can be a Nova-25 power supply made by ENI, Colorado Springs, Co.

[0054] Therefore, filter 15 is a 2 MHz band rejection filter. In some embodiments, the band

width of the filter can be approximately 100 kHz. Filter 15, therefore, prevents the 2 MHz power from the bias to substrate 16 from damaging power supply 18.

[0055] However, both RF and pulsed DC deposited films are not fully dense and most likely have columnar structures. These columnar structures are detrimental for optical wave guide applications due to the scattering loss caused by the structure. By applying a RF bias on wafer 16 during deposition, the deposited film can be dandified by energetic ion bombardment and the columnar structure can be substantially eliminated.

[0056] In the AKT-1600 based system, for example, target 12 can have an active size of about 675.70 X 582.48 by 4 mm in order to deposit films on substrate 16 that have dimension about 400 X 500 mm. The temperature of substrate 16 can be held at between -50C and 500C. The distance between target 12 and substrate 16 can be between about 3 and about 9 cm. Process gas can be inserted into the chamber of apparatus 10 at a rate up to about 200 sccm while the pressure in the chamber of apparatus 10 can be held at between about .7 and 6 millitorr. Magnet 20 provides a magnetic field of strength between about 400 and about 600 Gauss directed in the plane of target 12 and is moved across target 12 at a rate of less than about 20-30 sec/scan. In some embodiments utilizing the AKT 1600 reactor, magnet 20 can be a race-track shaped magnet with dimension about 150 mm by 600 mm.

[0057] A top down view of magnet 20 and wide area target 12 is shown in Figure 2. A film deposited on a substrate positioned on carrier sheet 17 directly opposed to region 52 of target 12 has good thickness uniformity. Region 52 is the region shown in Figure 1B that is exposed to a uniform plasma condition. In some implementations, carrier 17 can be coextensive with region 52. Region 24 shown in Figure 2 indicates the area below which both physically and chemically uniform deposition can be achieved, where physical and chemical uniformity provide refractive index uniformity, for example. Figure 2 indicates that region 52 of target 12 that provides thickness uniformity is, in general, larger than region 24 of target 12 providing thickness and chemical uniformity. In optimized processes, however, regions 52 and 24 may be coextensive.

[0058] In some embodiments, magnet 20 extends beyond area 52 in one direction, the Y direction in Figure 2, so that scanning is necessary in only one direction, the X direction, to provide a time averaged uniform magnetic field. As shown in Figures 1A and 1B, magnet 20 can be scanned over the entire extent of target 12, which is larger than region 52 of uniform

sputter erosion. Magnet 20 is moved in a plane parallel to the plane of target 12.

[0059] The combination of a uniform target 12 with a target area 52 larger than the area of substrate 16 can provide films of highly uniform thickness. Further, the material properties of the film deposited can be highly uniform. The conditions of sputtering at the target surface, such as the uniformity of erosion, the average temperature of the plasma at the target surface and the equilibration of the target surface with the gas phase ambient of the process are uniform over a region which is greater than or equal to the region to be coated with a uniform film thickness. In addition, the region of uniform film thickness is greater than or equal to the region of the film which is to have highly uniform optical properties such as index of refraction, density, transmission or absorptivity.

[0060] Target 12 can be formed of any materials, but is typically metallic materials such as, for example, combinations of Al and Si. Therefore, in some embodiments, target 12 includes a metallic target material formed from intermetallic compounds of optical elements such as Si, Al, Er and Yb. Additionally, target 12 can be formed, for example, from materials such as La, Yt, Ag, Au, and Eu. To form optically active films on substrate 16, target 12 can include rare-earth ions. In some embodiments of target 12 with rare earth ions, the rare earth ions can be pre-alloyed with the metallic host components to form intermetallics. See the '247 application.

[0061] In several embodiments of the invention, material tiles are formed. These tiles can be mounted on a backing plate to form a target for apparatus 10. Figure 3A shows an embodiment of target 12 formed with individual tiles 30 mounted on a cooled backplate 25. In order to form a wide area target of an alloy target material, the consolidated material of individual tiles 30 should first be uniform to the grain size of the powder from which it is formed. It also should be formed into a structural material capable of forming and finishing to a tile shape having a surface roughness on the order of the powder size from which it is consolidated. A wide area sputter cathode target can be formed from a close packed array of smaller tiles. Target 12, therefore, may include any number of tiles 30, for example between 2 to 20 individual tiles 30. Tiles 30 are finished to a size so as to provide a margin of non-contact, tile to tile, 29 in Figure 3A, less than about 0.010" to about 0.020" or less than half a millimeter so as to eliminate plasma processes between adjacent ones of tiles 30. The distance between tiles 30 of target 12 and the dark space anode or ground shield 19, in Figure 1B can be somewhat larger so as to provide non contact assembly or provide for thermal expansion tolerance during process chamber conditioning or

operation.

**[0062]** Several useful examples of target 12 that can be utilized in apparatus 10 according to the present invention include the following targets compositions: (Si/Al/Er/Yb) being about (57.0/41.4/0.8/0.8), (48.9/49/1.6/0.5), (92/8/0/0), (60/40/0/0), (50/50/0/0), (65/35/0/0), (70/30/0,0), and (50,48.5/1.5/0) cat. %, to list only a few. These targets can be referred to as the 0.8/0.8 target, the 1.6/.5 target, the 92-8 target, the 60-40 target, the 50-50 target, the 65-35 target, the 70-30 target, and the 1.5/0 target, respectively. The 0.8/0.8, 1.6/0.5, and 1.5/0 targets can be made by pre-alloyed targets formed from an atomization and hot-isostatic pressing (HIPing) process as described in the '247 application. The remaining targets can be formed, for example, by HIPing. Targets formed from Si, Al, Er and Yb can have any composition. In some embodiments, the rare earth content can be up to 10 cat. % of the total ion content in the target. Rare earth ions are added to form active layers for amplification. Targets utilized in apparatus 10 can have any composition and can include ions other than Si, Al, Er and Yb, including: Zn, Ga, Ge, P, As, Sn, Sb, Pb, Ag, Au, and rare earths: Ce, Pr, Nd, Pm, Sm, Eu, Gd, Tb, Dy Ho, Er, Tm Yb and Lu.

**[0063]** Optically useful materials to be deposited onto substrate 16 include oxides, fluorides, sulfides, nitrides, phosphates, sulfates, and carbonates, as well as other wide band gap semiconductor materials. To achieve uniform deposition, target 12, itself can be chemically uniform and of uniform thickness over an extended area.

**[0064]** Target 12 can be a composite target fabricated from individual tiles, precisely bonded together on a backing plate with minimal separation, as is discussed further with respect to Figure 3. In some embodiments, the mixed intermetallics can be plasma sprayed directly onto a backing plate to form target 12. The complete target assembly can also includes structures for cooling the target, embodiments of which have been described in U. S. Patent No. 5,565,071 to Demaray et al, and incorporated herein by reference.

**[0065]** Substrate 16 can be a solid, smooth surface. Typically, substrate 16 can be a silicon wafer or a silicon wafer coated with a layer of silicon oxide formed by a chemical vapor deposition process or by a thermal oxidation process. Alternatively, substrate 16 can be a glass, such as Corning 1737 (Corning Inc., Elmira, NY), a glass-like material, quartz, a metal, a metal oxide, or a plastic material. Substrate 16 can be supported on a holder or carrier sheet that may



be larger than substrate 16. Substrate 16 can be electrically biased by power supply 18.

[0066] In some embodiments, the area of wide area target 12 can be greater than the area on the carrier sheet on which physically and chemically uniform deposition is accomplished. Secondly, in some embodiments a central region on target 12, overlying substrate 16, can be provided with a very uniform condition of sputter erosion of the target material. Uniform target erosion is a consequence of a uniform plasma condition. In the following discussion, all mention of uniform condition of target erosion is taken to be equivalent to uniform plasma condition. Uniform target erosion is evidenced by the persistence of film uniformity throughout an extended target life. A uniformly deposited film can be defined as a film having a nonuniformity in thickness, when measured at representative points on the entire surface of a substrate wafer, of less than about 5 % or 10%. Thickness nonuniformity is defined, by convention, as the difference between the minimum and maximum thickness divided by twice the average thickness. If films deposited from a target from which more than about 20 % of the weight of the target has been removed continue to exhibit thickness uniformity, then the sputtering process is judged to be in a condition of uniform target erosion for all films deposited during the target life.

[0067] As shown in Figure 1B, a uniform plasma condition can be created in the region between target 12 and substrate 16 in a region overlying substrate 16. A plasma 53 can be created in region 51, which extends under the entire target 12. A central region 52 of target 12, can experience a condition of uniform sputter erosion. As discussed further below, a layer deposited on a substrate placed anywhere below central region 52 can then be uniform in thickness and other properties (i.e., dielectric, optical index, or material concentrations).

[0068] In addition, region 52 in which deposition provides uniformity of deposited film can be larger than the area in which the deposition provides a film with uniform physical or optical properties such as chemical composition or index of refraction. In some embodiments, target 12 is substantially planar in order to provide uniformity in the film deposited on substrate 16. In practice, planarity of target 12 can mean that all portions of the target surface in region 52 are within a few millimeters of a planar surface, and can be typically within 0.5 mm of a planar surface.

[0069] Other approaches to providing a uniform condition of sputter erosion rely on creating a large uniform magnetic field or a scanning magnetic field that produces a time-averaged,

uniform magnetic field. For example, rotating magnets or electromagnets can be utilized to provide wide areas of substantially uniform target erosion. For magnetically enhanced sputter deposition, a scanning magnet magnetron source can be used to provide a uniform, wide area condition of target erosion.

[0070] As illustrated in FIG. 1A, apparatus 10 can include a scanning magnet magnetron source 20 positioned above target 12. An embodiment of a scanning magnetron source used for dc sputtering of metallic films is described in U. S. Patent No. 5,855,744 to Halsey, et. al., (hereafter '744), which is incorporated herein by reference in its entirety. The '744 patent demonstrates the improvement in thickness uniformity that is achieved by reducing local target erosion due to magnetic effects in the sputtering of a wide area rectangular target. As described in the '744 patent, by reducing the magnetic field intensity at these positions, the local target erosion was decreased and the resulting film thickness nonuniformity was improved from 8%, to 4%, over a rectangular substrate of 400 x 500 mm.

[0071] The process gas utilized in reactor 10 includes an inert gas, typically argon, used as the background sputtering gas. Additionally, with some embodiments of target 12, reactive components such as, for example, oxygen may be added to the sputtering gas. Other gasses such as N<sub>2</sub>, NH<sub>3</sub>, CO, NO, CO<sub>2</sub>, halide containing gasses other gas-phase reactants can also be utilized. The deposition chamber can be operated at low pressure, often between about .5 millitorr and 8-10 millitorr. Typical process pressure is below about 3-5 millitorr where there are very few collisions in the gas phase, resulting in a condition of uniform "free molecular" flow. This ensures that the gas phase concentration of a gaseous component is uniform throughout the process chamber. For example, background gas flow rates in the range of up to about 200 sccm, used with a pump operated at a fixed pumping speed of about 50 liters/second, result in free molecular flow conditions.

[0072] The distance d, in Figure 1A, between target 12 and substrate 16 can, in some embodiments, be varied between about 4 cm and about 9 cm. A typical target to substrate distance d is about 6 cm. The target to substrate distance can be chosen to optimize the thickness uniformity of the film. At large source to substrate distances the film thickness distribution is dome shaped with the thickest region of the film at the center of the substrate. At close source to substrate distance the film thickness is dish shaped with the thickest film formed at the edge of the substrate. The substrate temperature can be held constant in the range of about -40 °C to

about 550°C and can be maintained at a chosen temperature to within about 10 °C by means of preheating substrate 16 and the substrate holder prior to deposition. During the course of deposition, the heat energy impressed upon the substrate by the process can be conducted away from substrate 16 by cooling the table on which substrate 16 is positioned during the process, as known to those skilled in the art. The process is performed under conditions of uniform gas introduction, uniform pumping speed, and uniform application of power to the periphery of the target as known to skilled practitioners.

[0073] The speed at which a scanning magnet 20 can be swept over the entire target can be determined such that a layer thickness less than about 5 to 10 Å, corresponding roughly to two to four monolayers of material, is deposited on each scan. Magnet 20 can be moved at rates up to about 30 sec/one-way scan and typically is moved at a rate of about 4 sec/one-way scan. The rate at which material is deposited depends on the applied power and on the distance  $d$ , in Figure 1A, between the target 12 and the substrate 16. For deposition of optical oxide materials, for example scanning speeds between about 2 sec/one-way scan across the target to 20-30 sec/scan provide a beneficial layer thickness. Limiting the amount of material deposited in each pass promotes chemical and physical uniformity of the deposited layer.

[0074] Substrate bias has been used previously to planarize RF sputtered deposited quartz films. A theoretical model of the mechanism by which substrate bias operates, has been put forward by Ting et al. (J. Vac. Sci. Technol. 15, 1105 (1978)). When power is applied to the substrate, a so-called plasma sheath is formed about the substrate and ions are coupled from the plasma. The sheath serves to accelerate ions from the plasma so that they bombard the film as it is deposited, sputtering the film, and forward scattering surface atoms, densifying the film and eliminating columnar structure. The effects of adding substrate bias are akin to, but more dramatic than, the effects of adding the low frequency RF component to the sputter source.

[0075] Biasing substrate 16 results in the deposited film being simultaneously deposited and etched. The net accumulation of film at any point on a surface depends on the relative rates of deposition and etching, which depend respectively, on the power applied to the target and to the substrate, and to the angle that the surface makes with the horizontal. The rate of etching is greatest for intermediate angles, on the order of 45 degrees, that is between about 30 and 60 degrees.

[0076] Powers to target 12 and substrate 16 can be adjusted such that the rates of deposition and etching are approximately the same for a range of intermediate angles. In this case, films deposited with bias sputtering have the following characteristics. At a step where a horizontal surface meets a vertical surface, the deposited film makes an intermediate angle with the horizontal. On a surface at an intermediate angle, there will be no net deposition since the deposition rate and etch rate are approximately equal. There is net deposition on a vertical surface.

[0077] Target 12 can have an active size of about 675.70 X 582.48 by 4 mm, for example, in a AKT-1600 based system in order to deposit films on a substrate 16 that is about 400 X 500 mm. The temperature of substrate 16 can be held at between -50C and 500C. The distance between target 12 and substrate 16 can be between 3 and 9 cm. Process gas can be inserted into the chamber of apparatus 10 at a rate of between about 30 to about 100 sccm while the pressure in the chamber of apparatus 10 can be held at below about 2 millitorr. Magnet 20 provides a magnetic field of strength between about 400 and about 600 Gauss directed in the plane of target 12 and is moved across target 12 at a rate of less than about 20-30 sec/scan.

[0078] Therefore, any given process utilizing apparatus 10 can be characterized by providing the power supplied to target 12, the power supplied to substrate 16, the temperature of substrate 16, the characteristics and constituents of the reactive gasses, the speed of the magnet, and the spacing between substrate 16 and target 12.

[0079] Sputtered oxide films according to some embodiments of the present invention can be deposited onto a Si wafer or thermal oxide wafers at pressure of between about 3 and about 6 mTorr. The ratio of O<sub>2</sub>/Ar gas flow can be set at a value to ensure that target 12 is operating within a poison mode. The poison mode is defined as the ratio where the oxide is etched from the surface of target 12 as fast as the oxide layer is formed. Operating in the poison mode results in the stoichiometric film. Sub-stoichiometric oxides may not be optically transparent. The pulsing frequency range for power supply 14 can be from about up to about 250 KHz. The frequency 40 KHz is approximately the lowest frequency at which no arcing will occur during deposition in, for example, the AKT 1600 based system. The reverse pulsing time is determined by the amount of arcing generated during the process. Longer reverse time means longer discharge time and thus less arcs. However, if the reverse time is too long, the deposition rate will decrease. Power supply 18 is a 2 MHz RF power supply operated at powers up to several

hundred Watts.

[0080] Figure 4 shows an embodiment of a process procedure 400 performed on apparatus 10. In step 401, the target is prepared for the deposition. In some embodiments, target 12 can be cleaned by pure Ar sputtering. In other words, apparatus 10 is operated with pure Ar gas only (referred to as the metal mode) in order to sputter away a surface layer of target 12.

[0081] Figure 7 shows the typical drift in the index of refraction with deposition of oxide layers for several different targets over different runs for each target. In Figure 7, the compositions of the target materials utilized in target 12 for the depositions shown are as follows: Si: 60 cat. % and Al: 40 cat. %; Si: 50 cat. % and Al: 50 cat. %; Si: 85 cat. % and Al: 15 cat. %; Si: 35 cat. % and Al: 65 cat. %; and Si: 92 cat. % and 8 cat. %. Each deposition was operated under the same process parameters: 4.5 kW of pulsed DC power at 200 kHz with a reverse time of 2.3  $\mu$ s applied to target 12, O<sub>2</sub> flow at 44 sccm, Ar flow at 30 sccm introduced to apparatus 10, 100 W of bias power at 2 MHz applied to substrate 16, the temperature of substrate 16 held at 200° C, and the distance between substrate 16 and target 12 being set at 6 cm. For each target measured, the index drifted up during repeated utilization.

[0082] Figure 8 shows the relationship between the index of refraction of a film deposited according to the present invention and the amount of aluminum in the composite target. As can be seen from Figure 8, the index of refraction of the deposited film depends strongly on the aluminum content. Therefore, as the aluminum in a metal target is depleted, the index of refraction drifts. In some embodiments, the ratio of Ar and O<sub>2</sub> utilized in the process can be maintained to provide films of uniform index over a large number of depositions on the target.

[0083] Reactive sputtering from a metal or metallic alloy target 12 can be characterized by two modes of operation. In the first mode, which is sometimes referred to as the 'metallic mode' the surface of target 12 is substantially metallic. This mode is characterized by a small addition of reactive gas to the inert gas flow of apparatus 10 as well as a higher impedance magnetron discharge. It is also characterized by incomplete oxidation of film deposited on substrate 16 and therefore higher index films. As the proportion of reactive to inert gas is increased, the sputter voltage at target 12 begins to fall at constant power.

[0084] Figure 5 shows the voltage on target 12 of an embodiment of apparatus 10 according to

the present invention as a function of process gas constitution. In the example illustrated in Figure 5, for example, a metallic target with composition .8 cat. % Er, .8 cat. % Yb, 57.4 cat. % Si and 41 cat. % Si, which can be formed as described in the '247 application, was sputtered in an embodiment of apparatus 10 based on the AKT-1600 PVD system with 6 kW of pulsed DC power at a frequency of 120 kHz and a reverse time of 2.3 micro seconds. The Argon gas flow was set at 60 sccm and the Oxygen gas flow was varied from zero up to 40 sccm. For more details regarding this deposition, see Example 1 below.

[0085] As shown in Figure 5, the voltage on target 12 during deposition (the "target voltage") was constant at about 420 Volts for oxygen flow rates up to about 20 sccm. This is clearly the metallic mode of operation for this embodiment of target 12. Films deposited in this range of oxygen flow are characterized as metallic with an oxygen content that increases with oxygen flow rate during deposition. As the oxygen flow is increased up to about 26 sccm, the voltage on target 12 begins to decrease, indicating that the surface of target 12 is beginning to form an oxide layer. The oxide layer on the surface of target 12 has a higher secondary electron yield under the influence of the Argon ion flux. The additional electron flux to the magnetron electron trap increases the ion production in the plasma, which, in turn, decreases the impedance of the plasma discharge in apparatus 10.

[0086] At slightly higher oxygen flow during deposition, the oxide layer on target 12 forms a continuous layer and the voltage of target 12 during deposition falls rapidly to the range of about 190 to about 270 Volts, indicating complete coverage of the surface of target 12 with an oxide that is at least as thick as the material removed during one scan of the magnetron. Under this condition, the rate of oxide formation on the surface of target 12 equals or exceeds the rate of sputter removal of the surface of target 12 by the moving magnetron 20. This condition is sometimes referred to as the 'poisoned mode'.

[0087] Under steady state DC voltage conditions, the oxide layer on target 12 soon charges up, leading to reduced rate of sputtering and increased micro-arc discharging in apparatus 10. This discharging leads to particulation of the oxide layer on target 12, which degrades the quality of a film deposited on substrate 16. In the example shown with Figure 5, the negative going DC Voltage is reduced at a frequency of 120 kHz to a positive value for a period of about 2.3 micro seconds per cycle, allowing charge neutralization of the surface of target 12, increasing the steady state sputter and deposition rates as well as decreasing the rate of micro-arcing.

[0088] In the case of a magnetron configuration of magnet 20 having a significant deep local target erosion (rather than a configuration of magnet 20 described above which yields uniform target erosion), the change in the target voltage of target 12 is more gradual with increasing oxygen flow since it is more difficult to establish an oxide condition at the center of an intense region of local erosion. The resulting deposited film, however, will be rich in metallic sputtered flux to the substrate in the region of higher sputter erosion, leading to non uniform stoicheometry and non-uniform indices of refraction in a film deposited on substrate 16. In the case of a scanning magnetron 20 with uniform target erosion, the change in the surface condition from metallic to poisoned is more abrupt, as the formation rate of the oxide increases to equal the sputter removal of the oxide over a wide area of the target. In this case, there is uniform distribution of sputtered oxide from the target. Uniform stoicheometry and uniform indices of refraction result for the film deposited on substrate 16.

[0089] Figure 8 shows the range of indices of refraction of films deposited for targets of differing silica and alumina compositions, as deposited and after a subsequent anneal step. In the case of a pure silicon target, the as-deposited index of refraction can be as high as 3.4 for pure amorphous silicon. In Figure 8, pure silica films (zero Al%) can be deposited with a reactive pulsed DC and substrate bias deposition according to the present invention with substantially complete oxygen stoicheometry, so as to approximate monolithic amorphous silica. The index of refraction of such films decreases with a subsequent heat treatment of between about 700-900° C, indicating somewhat more complete oxidation reaction of the material of the film together with some degree of stress relaxation of the film deposited on substrate 16.

[0090] At the opposite extreme, a pure aluminum embodiment of target 12 (100% Al) can be utilized to deposit films on substrate 16 under similar process conditions as is utilized to deposit pure silica films on substrate 16. In the case of the pure aluminum reactive deposition, the dependence of the index of refraction of the film deposited on substrate 16 on oxygen flow as well as on the frequency of the pulsed DC process can be examined. As a result, a larger range of effective index of refraction is achieved together with a reduced or zero dependence of the index on the subsequent anneal process. Six targets having differing aluminum composition were utilized to evaluate the index of refraction of sputtered films on substrate 16 of related composition. The largest change of index with the sputtering conditions is achieved for composition near the middle of the Al/Si composition range (about 50% Al and 50% Si).

**[0091]** Figure 7 shows the change in film index for oxide films for several embodiments of target 12 and processes with an initial 30 minutes of Argon only sputtering, followed by continuous deposition with an oxygen flow rate sufficient for operation in the poisonous mode. Note that the rate of increase in the index of refraction of a resulting film deposited on substrate 16 with continuous poisoned mode deposition is proportional to the concentration of aluminum in the composition of target 12. This result is due to the depletion of the aluminum from the target surface during the metallic sputtering or pre-condition process. The aluminum in target 12 is preferentially sputtered over the silicon in target 12, leaving the surface of target 12 rich in silicon. At the onset of poisoned mode sputtering, the film deposited on substrate 16 is rich in silica and demonstrates a systematic and reproducible decrease in index of refraction. During continuous poisoned mode deposition, the silicon rich surface of target 12 can be sputtered away and the aluminum portion substantially returned to the bulk composition of target 12. Consequently, a metallic pre-condition step can be utilized to achieve a subsequent process for the deposition of a film having an increasing index of refraction under conditions of oxide/metal stoichiometry.

**[0092]** In step 402 of Figure 4, substrate 16 is prepared. Substrate 16 can be mounted on carrier sheet 17 and placed in apparatus 10. In step 403, gas flow parameters are adjusted for the particular deposition to be performed. The constituency and flow rates of the process gas are fixed. In some embodiments, the ratio of Ar and O<sub>2</sub>, for example, can be set and the flow rate of each gas set. Further, the combination of flow rate and vacuum system of apparatus 10 determines the pressure during deposition in apparatus 10.

**[0093]** In step 404, the substrate temperature is set. Substrate 16 may be brought to temperature over a period of time. In step 405, the scan characteristics of magnet 20 are fixed. In step 406, the power setting for power supply 18 is set. Finally, in step 407, the parameters of pulsed DC power supply 14 is set, including the power, frequency, and reverse pulsing time. In step 408, then, a film that depends on the parameters of reactor apparatus 10 is deposited on substrate 16. In some embodiments, films deposited by procedure 400 are thermally annealed after deposition.

**[0094]** Figure 4 illustrates an example deposition process only. Embodiments of deposition processes according to the present invention can be performed in various different orders.



[0095] Figure 9 shows a chart of various deposition parameters according to the present invention for various embodiments of target 12 and the indices of refraction, both before and after an anneal step, for the resulting deposited film on substrate 16. Each deposition was accomplished with an embodiment of apparatus 10 based on the AKT 1600 PVD reactor. Anneals were accomplished at 725° C for 30 min. Specific examples of particular depositions and characteristics of the resulting films deposited on substrate 16 are further discussed below.

[0096] Figure 10 shows the dependence of the index of refraction of silica layers deposited according to the present invention with process conditions. Figure 11 shows the dependence of index of refraction on the O<sub>2</sub>/Ar flow ratio for the deposition of pure alumina according to the present invention. Figure 12 shows the dependence of index for pure alumina films on the frequency of the pulsed DC power applied to target 12. Both parameters can be utilized to reliably control the index of refraction of films deposited on substrate 16 over a range of index values without the use of an additional cationic species, a so called 'dopant'. A third process parameter that can be utilized to adjust the index of refraction of a film deposited on substrate 16 is the bias power applied to substrate 16. Increasing the oxygen flow ratio, the frequency of the pulsed DC power applied to target 12 or the bias power applied to substrate 16 will systematically increase the index of refraction of the alumina film deposited on substrate 16. In the case of pure alumina films, minor to no change in the index occurs due to a subsequent anneal process.

[0097] Figure 13 shows the index of refraction of a film deposited on substrate 16 from an embodiment of target 12 with about 92 cat. % of Si and about 8 cat. % of Al for a series of sequential depositions in an embodiment of apparatus 10 based on the AKT 4300 PVD reactor, each following a metallic process condition. For constant high oxygen flow conditions, a small upward trend in the index of refraction is observed. As is generally true, the index of films deposited with higher substrate bias power is systematically lower than films deposited without substrate bias.

[0098] Figure 14 shows the upward trend of the index of refraction after metallic mode precondition of an embodiment of target 12 having composition of about 83 cat. % Si and about 17 cat. % Al for a series of depositions in an embodiment of apparatus 10 based on the AKT 1600 PVD reaction. As is shown in Figure 14, longer metallic preconditioning of target 12 results in the index of refraction of the films deposited on substrate 16 having a higher rate of

increase than for cases with less prolonged metallic preconditioning of target 12. The vertical lines on Figure 14 indicate places where target 12 was preconditioned with only Ar for the indicated periods of time. Figure 15 shows a decrease in the change in index for sequential films with this embodiment of target 12 deposited with reduced oxygen flow rates at a constant total pressure. A flow rate for oxygen was determined so that the run to run variation for the index of refraction of the film deposited on substrate 16 from this target was about .0001 (see the circled data points on the graph of Figure 15) which is similar to the variance of the index over the entire wafer of substrate 16, which is about 70 parts per million.

[0099] In some embodiments, films deposited by a pulsed DC biased method according to the present invention are uniformly amorphous throughout their thickness. As has been discussed above, biasing of substrate 16 leads to densification and uniformity in the deposited film. Figures 16A through 16D show a TEM photograph of a film 1601 deposited according to the present invention. Further, diffraction patterns shown in Figures 16B, 16C and 16D at points a, b and c, respectively, in deposited film 1601 show that the film is amorphous through the thickness of the film. The diffraction patterns of Figures 16B, 16C and 16D show no effects of crystallization. Further, the smoothness of the surface of film 1601 indicates a defect free film. The film deposited in Figure 16A is deposited with an 0.8/0.8 target (i.e., a target having the composition 52.0 cat. % of Si, 41.0 cat. % of Al, 0.8 cat. % of Er and 0.8 cat. % of Yb). The film is deposited at 6 kW of 120 kHz pulsed DC power with a reverse time of 2.3  $\mu$ s. The Argon and Oxygen flow rates are 60 sccm and 28 sccm, respectively. Substrate 16 is biased with 100 W of power.

[0100] Figure 17 shows the optical loss per centimeter, measured at 1310 nm, using a three prism coupling to the so called slab mode of the film on a 10 micron oxide, silicon wafer. As deposited the biased, pulsed DC film from a 60 cat. % Si and 40 cat. %Al film demonstrated about .1dB/cm loss. After an 800° C anneal in air, the loss was less than the measurement sensitivity of the prism coupling method. This data clearly demonstrates that films deposited according to embodiments of the present invention can be used for the purpose of constructing low loss planar light wave circuits.

[0101] Deposition of films according to the present invention can be utilized to deposit cladding layers, active core layers, and passive core layers of an optical amplifier structure or optical

waveguide structure. In some applications, for example multiplexer structures, the separation between adjacent waveguides can be small, for example about 8  $\mu\text{m}$ . In some embodiments, the deposition parameters of the upper cladding layer can be adjusted to not only adjust the index of refraction of the layer, but also to insure that the spacing between adjacent waveguides is small.

[0102] Figure 18 shows an example planarization deposition over a multiplexer structure. In the particular example of upper cladding layer 1803 shown in Figure 18, the deposition parameters from a 92 cat. % Si and 8 cat. % Al is: 5.5 Kw of Pulsed DC power applied at 200 KHz with 2.2  $\mu\text{s}$  of reverse time, gas flow of 75 sccm Ar and 100 sccm O<sub>2</sub>, a substrate bias of 650 W (at 2 MHz), and a substrate temperature of 200 °C. Layer 1803 was deposited with an AKT 4300 based embodiment of apparatus 10. As shown in Figure 18, the layer thickness in areas other than over waveguide structures 1801 and 1802 is 11.4  $\mu\text{m}$ . Waveguide structures 1801 and 1802 are 8.20  $\mu\text{m}$  high waveguides and separated by 6.09  $\mu\text{m}$  at the base and by 8.40  $\mu\text{m}$  at their top. In Figure 18, the undercladding layer 1804 is about 1.98  $\mu\text{m}$  thick.

[0103] Figure 19 illustrates deposition of material over a structure. Upper cladding layer 1803, in region 1901, will be angled from the horizontal by an angle  $\theta$ . The deposition and etching rates of a deposited layer depends on the angle  $\theta$ . Figures 20 and 21 illustrate different cases of deposition and etch rates as a function of the angle  $\theta$ . The relationship between the rate of deposition and the etch rates can be adjusted by adjusting the deposition parameters. For example, the bias power to substrate 16 can be adjusted to control the relationship between the etch rates and deposition rates of material.

[0104] Figure 22 illustrates deposition rates over a structure 2201 as a function of time. In Figure 2201, h is the thickness deposited over structure 2201. The planarization when layer 1803 becomes flat.

[0105] The time for planarization can be estimated as

$$t_p = \frac{\frac{W}{2} \tan \alpha + H}{a_{\text{flat}} - \frac{a_{\text{min}}}{\cos \alpha}},$$

where W is the width of structure 2201, H is the height of structure 2201,  $a_{\text{flat}}$  refers to the

accumulation rate on the flat surface,  $a_{\min}$  refers to the accumulation rate on the minimum accumulation slope, and  $\alpha$  is the surface angle from the horizontal plane of the minimum accumulation slope.

[0106] Figure 23 shows a deposited film 1803 as shown in Figure 18, except that the bias power to substrate 16 is set to 400 W instead of 650 W. As can be seen in Figure 23, a keyhole 2301 is formed with an incomplete filling of uppercladding layer 1803 between structures 1801 and 1802. Deposition of uppercladding layer 1803 substantially follows the trends illustrated in Figures 19 through 22.

[0107] Figure 24 shows deposition as shown in Figure 18, except that the bias power to substrate 16 is set to 600 W instead of 650 W. As can be seen in Figure 24, keyhole 2301 has closed leaving a small line defect 2401 in the fill.

[0108] Figure 28 shows deposition as shown in Figure 18, except that the bias power to substrate 16 is set to 900 W instead of 650 W. As can be seen in Figure 28, the etch rate has been increased to such an extent that the corners of structures 1801 and 1802 have been etched to form slopes 2501 and 2502, respectively.

[0109] Therefore, as illustrated in figures 18 through 25, an uppercladding layer can be deposited in accordance with the present invention such that it fills the space between adjacently placed waveguides. In general, the parameters can be optimized for index control and the bias power to substrate 16 can be adjusted for fill. In some embodiments, other parameters (e.g., the constituency of process gas, frequency and power of pulsed DC power source 14, and other parameters) in order to adjust the deposition and etch rates and thereby effectively planarize the structure as described.

[0110] Therefore, depositions of various films in embodiments of apparatus 10 according to the present invention with several embodiments of target 12 and the effects on index of refraction, uniformity of films, and fill characteristics of varying several of the process parameters has been discussed above. In some embodiments, stress effects due to wafer bowing of substrate 16 can also be reduced. Wafer bowing of substrate 16 can be reduced, reducing the stress in a film deposited on substrate 16, by, for example, depositing a film on the backside of substrate 16 before deposition of a film on substrate 16. In some embodiments, a film having a similar

thickness of a similar layer of material can be deposited on backside of substrate 16 prior to deposition of the film on substrate 16 according to the present invention. The wafer bowing resulting from differing thermal expansions of the film and substrate 16 is therefore countered by a similar stress from another film deposited on the backside of substrate 16.

[0111] Several specific examples film depositions utilizing apparatus 10 are discussed below. Further, examples of optical amplifiers produced utilizing the ceramic tiles according to the present invention are presented. These examples are provided for illustrative purposes only and are not intended to be limiting. Unless otherwise specified, apparatus 10 utilized in the following examples was based on the AKT 1600 reactor. Further, unless otherwise specified, the temperature of substrate 16 was held at about 200° C and the distance between substrate 16 and target 12 was 4 s/scan. The separation between substrate 16 and target 12 is about 6 cm.

#### EXAMPLE 1

[0112] An AKT 1600 based reactor can be utilized to deposit a film. In this example, a wide area metallic target of dimension 550X 650 mm with composition (Si/Al/Er/Yb) being about 57.0 cat. % Si, 41.4 cat. % Al, 0.8 cat. % Er, and 0.8 cat. % Yb (a “.8/.8” target) was fabricated as described in the ‘247 patent.

[0113] In step 402, a 150 mm P-type silicon wafer substrate was placed in the center of a 400x500 mm glass carrier sheet 17. Power supply 14 was set to supply 6000 watts of pulse DC power at a frequency of 120KHz with a reverse pulsing time of about 2.3us. Magnet 20, which is a race-track shaped magnet of approximate dimension 150mmx600mm, was swept over the backside of the target at a rate of about 4 seconds per one-way scan. The temperature of substrate 16 was held at 200C and 100W of 2 MHz RF power was applied to substrate 16. The target 12 to substrate 16 distance was about 6.5 cm. The sputtering gas was a mixture of Argon and Oxygen. Substrate 16 and carrier 17 was preheated to 350° C for at least 30min prior to deposition. The active film was deposited in the poison mode. Deposition efficiency was approximately 1um/hr.

[0114] Figure 5 shows the hysteresis curve of this particular embodiment of target 12. When target 12 under goes the transition from metallic to poison mode, the target voltage drops from

an average of about 420V to an average of about 260V. Before each film deposition, in step 401, target 12 is cleaned by pure Argon sputtering in the metallic mode. Then target is then conditioned in poison mode with the oxygen flow much higher than the flow required at the transition region.

[0115] Tables 1A through 1C shows some effects on the deposited films of depositions with the 0.8/0.8 target under different operating conditions. Table 1A includes photoluminescence (pumped at 532 nm) and index of refraction for films deposited on substrate 16 with different Ar/O<sub>2</sub> gas flow ratios with no bias power applied to substrate 16.

Table 1A

Target Power (KW)	Ar/O2	Frequency (KHz)	Reverse Pulsing Time (us)	Bias (W)	PL/um (532nm)	Index
6	30/42	200	2.3	0	1973	1.5142
6	30/36	200	2.3	0	2358	1.5215
6	60/30	200	2.3	0	3157	1.5229
6	60/28	200	2.3	0	3421	1.5229

[0116] Table 1B shows the variation in photoluminescence (pumped at 532 nm) and index of refraction of the film deposited on substrate 16 with deposition processes having with the same Ar/O<sub>2</sub> ratios but different pulsed DC power frequencies from power supply 14.

Table 1B

Target Power (KW)	Ar/O2	Frequency (KHz)	Reverse Pulsing Time (us)	Bias (W)	PL/um (532nm)	Index
3	60/28	100	2.3	100	1472	1.5146
4	60/28	75	3.5	100	2340	1.5189
6	60/28	120	2.3	100	5178	1.5220

[0117] Table 1C shows the photoluminescence and index as deposited where the bias power to substrate 16 is varied.

Table 1C

Target Power (KW)	Ar/O2	Frequency (KHz)	Reverse Pulsing Time (us)	Bias (W)	PL/um (532nm)	Index
6	60/28	200	2.3	0	3657	1.5230
6	60/28	200	2.3	100	2187	1.5244
6	60/28	200	2.3	200	3952	1.5229
6	60/28	200	2.3	300	5000	1.5280

[0118] The photoluminescence values can be measured with a Phillips PL-100. The deposited film can be pumped with a 532 nm laser and the luminescence at 980 is measured. The index is the index of refraction. Typically, films deposited are annealed in order to activate the erbium. Figure 6 shows the photoluminescence and lifetime versus anneal temperature for a typical film deposited as described in this example.

### EXAMPLE 2

[0119] A waveguide amplifier can be deposited according to the present invention. An embodiment of target 12 having composition 57.4 cat. % Si, 41.0 cat. % Al, 0.8 cat. % Er 0.8 cat. % Yb (the “.8/.8 target”) can be formed as disclosed in the ‘245 application. The Er-Yb (0.8/0.8) co-doped Alumino-Silicate film was deposited onto a 6 inch wafer of substrate 16 which includes a 10 μm thick thermal oxide substrate, which can be purchased from companies such as Silicon Quest International, Santa Clara, CA. Target 12 was first cleaned by sputtering with Ar (80 sccm) only in the metallic mode. Target 12 was then conditioned in poison mode by flowing 60 sccm of Argon and 40 sccm of oxygen respectively. The power supplied to target 12 during conditioning was kept at about 6 kW.

[0120] An active core film was then deposited on substrate 16. The thickness of the deposited film is approximately 1.2 μm. The deposition parameters are shown in Table 2.

Table 2.

Target Power (KW)	Ar/O2 (sccm)	Pulsing Frequency (KHz)	Bias (W)	Reverse pulsing time (us)
6	60/28	120	100	2.3

[0121] A straight waveguide pattern can then formed by standard photolithography techniques. The active core was etched using reactive ion etch followed by striping and cleaning. Next, a 10 μm top cladding layer is deposited using a similar deposition process according to the present invention. An embodiment of target 12 with composition 92 cat. % Si and 8 cat. % Al as shown in Figure 9 to form the top cladding layer. The index difference between the top cladding layer and the active layer is about 3.7%. The amplifier is then annealed at 725° C for about 30 min (see Figure 6, for example).

[0122] The erbium excited-state lifetime and the up-conversion coefficient were measured to be 3ms and  $4.5 \times 10^{-18} \text{ cm}^3/\text{s}$ , respectively. A net gain of about 4dB for small signal (about -20 dBm) with fiber to waveguide and to fiber coupling was obtained. Waveguide length was 10cm and the width was about 1.5 to 8 μm. The coupling loss between the fiber and the waveguide is 3-4 dB/facet, and passive excess loss is 0.1-0.2 dB/cm for 3um waveguide. The waveguide was both co- and counter pumped with 150 mW 980nm laser per facet.

### EXAMPLE 3

[0123] This example describes production of a dual core Erbium/Yttrium co-doped amplifier according to the present invention. In one example, substrate 16 is a silicon substrate with an undercladding layer of thermally oxidized SiO<sub>2</sub> of about 15 μm thick. Substrate 16 with the thermal oxide layer can be purchased from companies such as Silicon Quest International, Santa Clara, CA. A layer of active core material is then deposited on substrate 16 with a Shadow Mask as described in the '138 application. Use of a shadow mask results in a vertical taper on each side of a finished waveguide which greatly enhances the coupling of light into and out of the waveguide.



[0124] Active core layer is deposited from a 0.8/0.8 target as described in the '247 application having composition 57.4 cat. % Si, 41.0 cat. % Al, 0.8 cat. % Er, and 0.8 cat. % Yb. The deposition parameters are identical to that of Example 2 described above. The active layer is deposited to a thickness of about 1.2  $\mu\text{m}$ .

[0125] A passive layer of aluminasilicate is then deposited over the active layer. A passive layer of about 4.25  $\mu\text{m}$  thickness can be deposited with an embodiment of target 12 having composition of Si/Al of about 87 cat. % Si and about 13 cat. % Al. The passive layer and active layer are then patterned by standard lithography techniques to form a core that has a width of about 5.0  $\mu\text{m}$  for the active core and tapering to about 3.5  $\mu\text{m}$  at the top of the passive core with an effective length of about 9.3 cm.

[0126] Upper cladding layer is then deposited from a Si/Al target of 92 cat. % Si and 8 cat. % Al. Deposition of the upper cladding layer is shown in Figure 9. In some embodiments, the upper cladding layer can be deposited with a non-biased process. The thickness of the upper cladding layer can be about 10  $\mu\text{m}$ . The amplifier formed by this process is then annealed at 725° C for about 30 min.

[0127] The as-deposited Erbium and Ytterbium concentrations in the active layer of core 303 is  $2.3 \times 10^{20} \text{ cm}^{-3}$  Erbium concentration and  $2.3 \times 10^{20} \text{ cm}^{-3}$  Ytterbium concentration. The index of the core is 1.508 and the index of cladding layers are 1.4458 for undercladding layer 302 and 1.452 for uppercladding layer 304. The parameter  $\Delta n/n$  is therefore about 5.0%.

[0128] A reverse taper mode size converter, *see* the '138 application, is utilized for coupling light into waveguide amplifier 300. The insertion loss at 1310 nm is about 2 dB. Figure 26 shows the amplifier performance of this example. In Figure 26, amplifier 300 is pumped with 150 mW from one side pumping with 984 nm light. Gain flattening is achieved within about 1 dB in the range 1528 nm to 1562 nm for small input signals (-20 dBm). For large input signals (0 dBm), gain flattening is also achieved within about 1 dB.

#### EXAMPLE 4

[0129] Another example of production of a waveguide amplifier is described here. Again, substrate 16 can be a Si wafer with about a 15  $\mu\text{m}$  thick thermal oxide as can be purchased from Silicon Quest International, Santa Clara, CA. The embodiment of target 12 for the deposition of the active core can have a composition of about 50 cat. % Si, 48.5 cat. % Al, 1.5 cat. % Er (the "1.5/0" target), which can be fabricated as discussed in the '138 application. Target 12 was first cleaned by sputtering with Ar (80 sccm) only in the metallic mode. Target 12 was then conditioned in poison mode by flowing 60 sccm of Argon and 40 sccm of oxygen respectively.

[0130] The pulsed DC power supplied to target 12 was about 6 kW. Whenever a brand new target was used or when the target has been expose to atmosphere, a long time of condition (for example more than 30hrs of conditioning) may be necessary to ensure films with the best active core property (longest life time and highest photoluminescence) are deposited. Substrate 16 is then preheat at about 350° C for about 30min before deposition.

[0131] The active core film was deposited onto a 6 inch thermal oxide wafer, which has been previously discussed, from the 1.5/0 target. The thermal oxide thickness was about 10  $\mu\text{m}$  as described in previous examples. The active core is deposited to a thickness of about 1.2  $\mu\text{m}$  with a deposition time of approximately 1 hr. The process condition are as listed in Table 4 below.

Table 3

Target Power (KW)	Ar/O2 (sccm)	Pulsing Frequency (KHz)	Bias (W)	Reverse pulsing time (us)
6	60/28	120	100	2.3

[0132] A straight waveguide pattern can then be formed by a standard photolithography procedure. The active core was etched using reactive ion etch followed by stripping and cleaning. Finally, a 10  $\mu\text{m}$  top cladding layer is deposited using a similar process. A target having composition 92 cat. % Si and 8 cat. % Al with deposition parameters as described in Figure 9 was used to deposit the top cladding. The difference between the index of refraction between the core and the cladding is then about 3.7%.

[0133] In this example, annealing of the amplifier structure was performed at various anneal temperatures. The results of the various anneals are shown graphically in Figures 27 and 28. Figure 27 shows both internal gain in the C-band and insertion loss at 1310 nm of a 2.5 $\mu$ m wide, 10.1 cm long waveguide as deposited in this example as a function of annealing temperature. The life time in ms and up-conversion constants in cm<sup>-3</sup>/s measurements for the deposited active core film at different annealing temperature are shown in Figure 28.

#### EXAMPLE 5

[0134] One of the problems encountered during the reactive sputtering from an alloy metallic target is that the film composition drifts from run to run due to the difference in sputtering yields from the elements that forms the target alloy. For example, with Ar as a sputtering gas, the sputtering yield of Aluminum is about 3-4 times that of Silicon, while sputtering yield of Alumina is only about 50% that of Silica. Therefore, during the metal burn in; more Aluminum is sputtered from the target, resulting in a Si rich target surface. When sputtering in the poison mode, more Silica will be removed from target. Thus, as deposition goes on, the composition of the film deposited on substrate 16 will drift from lower Alumina concentration to higher Alumina concentration. This results in the index of refraction of a film drifting up with subsequent depositions from a target 12, as is shown for the deposition described in Example 4 in Figure 29. Figure 30 shows the drift in photoluminescence pumped at 532 nm with subsequent depositions. Figure 31 shows drift in the excited state lifetime with subsequent depositions from a target. The embodiment of target 12 utilized in Figures 29 through 31 is the 1.5/0 target and the deposition parameters are as described above in Example 4.

[0135] The drift can be stabilized by recondition target 12 prior to deposition. The recondition process (or burn in) consists of both sputtering in metallic mode and then sputtering in poison mode to condition target 12. The burn in time in metallic mode needs to be as short as possible and at the same time insure no arcing during the poison mode deposition. Figure 32 shows the

much improved drift in the index of refraction and the photoluminescence when target 12 is reconditioned between subsequent depositions.

EXAMPLE 6

[0136] This example describes the fabrication of another Er-Yb codoped waveguide amplifier according to the present invention. The active core is deposited with an embodiment of target 12 with composition about 49 cat. % Si, 48 cat. % Al, 1.6 cat. % Er and 0.5 cat. % Yb, which can be fabricated as described in the '247 application. Target 12 was first cleaned by sputtering with Ar (80 sccm) only in the metallic mode. Target 12 was then conditioned in poison mode by flowing 60 sccm of Argon and 40 sccm of oxygen respectively. The pulsed DC power supplied to target 12 was kept at 5 kW. Table 4 shows photoluminescence and index of refraction of as-deposited films from this example at some typical process conditions. The units for photoluminescence are the number of counts per micron. Lifetime and photoluminescence measured after annealing at various different temperatures are shown in Table 5.

Target 4

Target Power (KW)	Ar/O2 (sccm)	Pulsing Frequency (KHz)	Bias (W)	Reverse pulsing time (us)	532 nm PL/um	Index
5	60/34	120	100	2.3	3367	1.5333
5	60/30	120	100	2.3	3719	1.5334

Table 5

Anneal Temperature °C	Life Time (ms)	PL (532nm)/um
725	3	7000
775	3	7000
800	4	7500
825	4.7	8560
850	5.8	10000
900	6.9	17000

[0137] A waveguide amplifier was fabricated using this material in the similar fashion as described in examples 2-4. The active core was first deposited on substrate 16, which includes a

10um thermal oxide layer, using the following deposition parameters: target power 5KW, pulsing frequency 120KHz, bias 100W, reverse time 2.3us, Argon and Oxygen flow are 60 sccm and 30sccm respectively. The active core thickness is deposited to a thickness about 1.2um, which takes approximately 1 hr. All wafers are preheated at about 350° C for 30min before deposition. A straight waveguide pattern is then formed by standard photolithography procedure. The active core was etched using reactive ion etch following by striping and cleaning. Next, a 10um top cladding layer is deposited using similar process. The "92/8" (92 cat. % Si and 8 cat. % Al) metallic target was used to deposit top clad according to deposition parameters shown in Figure 9, resulting in a 4 % index difference between active core and cladding. The wave guide was then annealed at 800° C for about 30 min.

[0138] This waveguide was tested for gain using the method described in previous examples. However no net gain was observed from this waveguide since the passive loss was too high.

#### EXAMPLE 7

[0139] In addition to active material layers (i.e., layers having rare-earth ion concentrations), passive layers can also be deposited. Figure 9 shows deposition parameters for several target compositions, including some targets for deposition of passive (i.e., alloys of Al and Si with no rare earth ion concentration) layers. In this example, an embodiment of target 12 with a material composition of pure silicon is utilized.

[0140] Apparatus 10 can be based on an AKT 1600 reactor and deposited with about 1 to 3 kW of pulsed DC target power supplied to target 12. Particular depositions have been accomplished at 2.5 kW and 1.5 kW. The frequency of the pulsed DC power is between about 100 and 200 Khz. Some depositions were performed at 200 kHz while others were performed at 100 kHz. The reverse time was varied between about 2 μs and about 4 μs with particular depositions performed at 2.3 μs and 3.5 μs. The bias power to substrate 16 was set to zero.

[0141] Index variation of SiO<sub>2</sub> films with bias to substrate 16 and deposition rates as a function of bias power to substrate 16 is shown in Figure 10.

[0142] The process gas included a mixture of Ar, N<sub>2</sub> and O<sub>2</sub>. The Ar flow rates was set at 20 sccm while the O<sub>2</sub> flow rate was varied between about 5 and about 20 sccm and the N<sub>2</sub> flow rate was varied from about 2 to about 35 sccm. Figure 33 shows the variation in the index of refraction of a film deposition on substrate 16 as the O<sub>2</sub>/N<sub>2</sub> ratio is varied.

#### EXAMPLE 8

[0143] Alternatively, films can be deposited on substrate 16 from a pure alumina target. In an example deposition with an embodiment of target 12 of alumina in an embodiment of apparatus 10 based on the AKT 1600 reactor, the pulsed DC target power was set at 3 kW and the frequency was varied between about 60 kHz and 200 kHz. The reverse time was set at 2.5 μs. Again, no bias power was supplied to substrate 16. The O<sub>2</sub> flow rate was varied from about 20 to about 35 sccm, with particular depositions performed at 22 and 35 sccm. The Ar flow rate was set at 26 sccm. A post deposition anneal of substrate 16 at 800° C for 30 min. was performed.

[0144] Figure 12 shows the variation of refractive index of the film deposited on substrate 16 with varying frequency of the pulsed DC power supplied to target 12. Figure 11 shows the variation in refractive index of a film deposited on substrate 16 with varying O<sub>2</sub>/Ar ratio. As can be seen from Figures 33, 34 and 35, the index of refraction of films deposited from alumina can be adjusted by adjusting the process gas constituents or by adjusting the frequency of the pulsed DC power supplied to target 12 during deposition.

#### EXAMPLE 9

[0145] Additionally, passive films can be deposited from targets having a composition of Si and Al. For example, layers have been deposited from embodiments of target 12 with composition 83 % Si and 17 % Al. About 4.5 kW of pulsed DC power at about 200 kHz frequency was supplied to target 12. The reverse time was about 2.2 μs. A bias power of about 150 W was

supplied to substrate 16 during deposition. Figures 14 and 15 show variation of the index of refraction for subsequent runs from this target.

[0146] The examples and embodiments discussed above are exemplary only and are not intended to be limiting. One skilled in the art can vary the processes specifically described here in various ways. Further, the theories and discussions of mechanisms presented above are for discussion only. The invention disclosed herein is not intended to be bound by any particular theory set forth by the inventors to explain the results obtained. As such, the invention is limited only by the following claims.

2007-07-20 10:00:00

## Claims

We claim:

1. A method of depositing a film on a substrate, comprising:
  - providing pulsed DC power through a filter to a target;
  - providing bias power to a substrate positioned opposite the target;
  - providing process gas between the target and the substrate,wherein the filter protects a pulsed DC power supply from the bias power.
2. The method of Claim 1, further including holding the temperature of the substrate substantially constant.
3. The method of Claim 1, wherein providing pulsed DC power through the filter includes supplying up to about 10 kW of power at a frequency of between about 40 kHz and about 350 kHz and a reverse time pulse between about 1.3 and 5  $\mu$ s.
4. The method of Claim 1, wherein providing bias power to the substrate includes supplying up to 1000 W of RF power to the substrate.
5. The method of Claim 4, wherein the filter is a band reject filter at the frequency of the bias power.
6. The method of claim 4, wherein the bias power is zero.
7. The method of Claim 1, wherein the film is an upper cladding layer of a waveguide structure and the bias power is optimized to provide planarization.
8. The method of Claim 1, wherein the process gas includes a mixture of Oxygen and Argon.
9. The method of Claim 9, wherein the Oxygen flow is adjusted to adjust the index of refraction of the film.
10. The method of Claim 8, wherein the process gas further includes nitrogen.



11. The method of Claim 1, wherein providing pulsed DC power to a target includes providing pulsed DC power to a target which has an area larger than that of the substrate.
12. The method of Claim 1, further including uniformly sweeping the target with a magnetic field.
13. The method of Claim 12, wherein uniformly sweeping the target with a magnetic field includes sweeping a magnet in one direction across the target where the magnet extends beyond the target in the opposite direction.
14. The method of Claim 1, further including depositing a film on the backside of target 12.
15. A reactor according to the present invention, comprising:
  - a target area for receiving a target;
  - a substrate area opposite the target area for receiving a substrate;
  - a pulsed DC power supply; and
  - a bias power supply coupled to the substrate.
16. The reactor of Claim 15, wherein the target has a surface area greater than the surface area of the substrate.
17. The reactor of Claim 15, further including a scanning magnet which provides uniform erosion of the target.
18. The reactor of Claim 17, wherein the scanning magnet scans across the target in a first direction and extends in a second direction perpendicular to the first direction.
19. The reactor of Claim 18, wherein the magnet extends beyond the target in the second direction.
20. A method of depositing a film on a substrate, comprising:
  - conditioning a target;
  - preparing the substrate;

adjusting the bias power to the substrate;

setting the process gas flow; and

applying pulsed DC power to the target to deposit the film.

21. The method of Claim 20, wherein conditioning the target includes sputtering with the target in a metallic mode to remove the surface of the target and sputtering with the target in poisonous mode to prepare the surface.
22. The method of Claim 21, wherein setting the process gas flow includes adjusting constituents in order to adjust the index of refraction of the film.
23. The method of Claim 21, wherein applying pulsed DC power includes setting the frequency in order to adjust the index of refraction of the film.
24. The method of Claim 21, further including adjusting a temperature of the substrate in order to adjust the index of refraction of the film.
25. A method of forming a waveguide amplifier, comprising:
- providing a substrate with an undercladding layer;
  - providing a target having a concentration of rare-earth ions opposite the substrate;
  - supplying process gas between the target and the substrate;
  - applying pulsed DC power through a filter to the target to deposit a film;
  - patterning the film to form a core;
  - depositing an uppercladding layer over the core.
26. The method of Claim 25, wherein providing a substrate includes providing a silicon substrate with a thermal oxide layer.
27. The method of Claim 25, wherein providing a target includes providing a target having a concentration of up to about 5 cat. % of rare earth ions.

10101863-031602

28. The method of Claim 27, wherein providing a target includes providing a target of Al and Si.
29. The method of claim 25, wherein providing a target includes providing a target with a concentration of Al.
30. The method of Claim 29, wherein providing a target includes providing a target with a concentration of Si.
31. The method of Claim 29, wherein providing a target includes providing a target with a concentration of rare earth ions.
32. The method of Claim 25, further including providing bias power to the substrate.
33. The method of Claim 25, further including scanning a magnet over the target.
34. The method of Claim 25, wherein scanning the magnet over the target includes moving the magnet in a first direction.
35. The method of Claim 34, wherein the magnet extends beyond the target in a second direction perpendicular to the first direction.
36. The method of Claim 25, wherein the target has a surface area greater than the surface area of the substrate.
37. The method of Claim 32, wherein the filter rejects power at a frequency of the bias power.
38. A sputtering apparatus, comprising:
- means for providing pulsed DC power to a target; and
  - means for providing bias power to a substrate.
39. The apparatus of Claim 38, further including
- means for providing process gas between the target and the substrate.

## **Biased Pulse DC Reactive Sputtering of Oxide Films**

Hongmei Zhang  
Mukundan Narasimhan  
Ravi Mullapudi  
Richard E. Demaray

### **Abstract**

A biased pulse DC reactor for sputtering of oxide films is presented. The biased pulse DC reactor couples pulsed DC at a particular frequency to the target through a filter which filters out the effects of a bias power applied to the substrate, protecting the pulsed DC power supply. Films deposited utilizing the reactor have controllable material properties such as the index of refraction. Optical components such as waveguide amplifiers and multiplexers can be fabricated using processes performed on a reactor according to the present invention.

10101863-031602

**DECLARATION FOR PATENT APPLICATION  
AND POWER OF ATTORNEY**

As a below named inventor, I hereby declare that:

My residence, post office address and citizenship are as stated below adjacent to my name.

I believe I am the original, first and sole inventor (if only one name is listed below) or an original, first and joint inventor (if plural names are listed below) of subject matter (process, machine, manufacture, or composition of matter, or an improvement thereof) which is claimed and for which a patent is sought by way of the application entitled

**Biased Pulse DC Reactive Sputtering of Oxide Films**

- which (check)  is attached hereto.  
 and is amended by the Preliminary Amendment attached hereto.  
 was filed on \_\_\_\_\_ as Application Serial No. \_\_\_\_\_  
 and was amended on \_\_\_\_\_ (if applicable).

I hereby state that I have reviewed and understand the contents of the above identified specification, including the claims, as amended by any amendment referred to above.

I acknowledge the duty to disclose information, which is material to patentability as defined in Title 37, Code of Federal Regulations, § 1.56.

I hereby claim foreign priority benefits under Title 35, United States Code, § 119(a)-(d) of any foreign application(s) for patent or inventor's certificate or any PCT international application(s) designating at least one country other than the United States of America listed below and have also identified below any foreign application(s) for patent or inventor's certificate or any PCT international application(s) designating at least one country other than the United States of America filed by me on the same subject matter having a filing date before that of the application(s) of which priority is claimed:

Prior Foreign Application(s)			Priority Claimed	
Number	Country	Day/Month/Year Filed	Yes	No
N/A			<input type="checkbox"/>	<input type="checkbox"/>

I hereby claim the benefit under Title 35, United States Code, § 119(e) of any United States provisional application(s) listed below:

Provisional Application Number	Filing Date
N/A	

I hereby claim the benefit under Title 35, United States Code, § 120 of any United States application(s) or PCT international application(s) designating the United States of America listed below and, insofar as the subject matter of each of the claims of this application is not disclosed in the prior application(s) in the manner provided by the first paragraph of Title 35, United States Code, § 112, I acknowledge the duty to disclose information, which is material to patentability as defined in Title 37, Code of Federal Regulations, § 1.56, which became available between the filing date of the prior application(s) and the national or PCT international filing date of this application:

Application Serial No.	Filing Date	Status (patented, pending, abandoned)
N/A		

2009 FEB 23 10:00 AM

I hereby appoint the following practitioners to prosecute this application and to transact all business in the United States Patent and Trademark Office connected therewith:

Customer Number 24251



Please direct all telephone calls to:

Gary J. Edwards

Telephone: 408-453-9200

I declare that all statements made herein of my own knowledge are true, all statements made herein on information and belief are believed to be true, and all statements made herein are made with the knowledge that whoever, in any matter within the jurisdiction of the Patent and Trademark Office, knowingly and willfully falsifies, conceals, or covers up by any trick, scheme, or device a material fact, or makes any false, fictitious or fraudulent statements or representations, or makes or uses any false writing or document knowing the same to contain any false, fictitious or fraudulent statement or entry, shall be subject to the penalties including fine or imprisonment or both as set forth under 18 U.S.C. 1001, and that violations of this paragraph may jeopardize the validity of the application or this document, or the validity or enforceability of any patent, trademark registration, or certificate resulting therefrom.

2009 FEB 03 09:34 AM

Full name of **first** joint inventor: Hongmei Zhang  
Inventor's Signature: \_\_\_\_\_ Date: \_\_\_\_\_

Residence: \_\_\_\_\_  
Post Office Address: \_\_\_\_\_ Citizenship: \_\_\_\_\_

Full name of **third** joint inventor: Mukundan Narasimhan  
Inventor's Signature: \_\_\_\_\_ Date: \_\_\_\_\_

Residence: \_\_\_\_\_  
Post Office Address: \_\_\_\_\_ Citizenship: \_\_\_\_\_

Full name of **second** joint inventor: Ravi B. Mullapudi  
Inventor's Signature: \_\_\_\_\_ Date: \_\_\_\_\_

Residence: San Jose, California  
Post Office Address: 2117 Shiangzone Court  
San Jose, California 95121  
Citizenship: India

Full name of **fourth** joint inventor: Richard E. Demaray  
Inventor's Signature: \_\_\_\_\_ Date: \_\_\_\_\_

Residence: Portola Valley, California  
Post Office Address: 190 Fawn Lane  
Portola Valley, California 94028  
Citizenship: USA

# CLAIMS ONLY

SERIAL NO.	FILING DATE
APPLICANT(S)	

## CLAIMS

	AS FILED		AFTER 1st AMENDMENT		AFTER 2nd AMENDMENT			*		*		*	
	IND.	DEP.	IND.	DEP.	IND.	DEP.		IND.	DEP.	IND.	DEP.	IND.	DEP.
1	1						51						
2		1					52						
3		1					53						
4		1					54						
5		1					55						
6		1					56						
7		1					57						
8		1					58						
9		1					59						
10		1					60						
11		1					61						
12		1					62						
13		1					63						
14		1					64						
15	1						65						
16		1					66						
17		1					67						
18		1					68						
19		1					69						
20	1						70						
21		1					71						
22		1					72						
23		1					73						
24		1					74						
25	1						75						
26		1					76						
27		1					77						
28		1					78						
29		1					79						
30		1					80						
31		1					81						
32		1					82						
33		1					83						
34		1					84						
35		1					85						
36		1					86						
37		1					87						
38	1						88						
39		1					89						
40							90						
41							91						
42							92						
43							93						
44							94						
45							95						
46							96						
47							97						
48							98						
49							99						
50							100						
TOTAL IND.	5						TOTAL IND.						
TOTAL DEP.	34						TOTAL DEP.						
TOTAL CLAIMS	39						TOTAL CLAIMS						

\* MAY BE USED FOR ADDITIONAL CLAIMS OR ADMENDMENTS

BEST AVAILABLE COPY

**PATENT APPLICATION FEE DETERMINATION RECORD**  
Effective October 1, 2001

Application or Docket Number

**CLAIMS AS FILED - PART I**

	(Column 1)	(Column 2)
TOTAL CLAIMS	39	
FOR	NUMBER FILED	NUMBER EXTRA
TOTAL CHARGEABLE CLAIMS	39 minus 20 = *	19
INDEPENDENT CLAIMS	5 minus 3 = *	2
MULTIPLE DEPENDENT CLAIM PRESENT <input type="checkbox"/>		

**SMALL ENTITY TYPE**  OR

**OTHER THAN SMALL ENTITY**

RATE	FEE
BASIC FEE	370.00
9 X \$ 9 =	171
2 X 42 =	84
+140 =	
<b>TOTAL</b>	<b>625</b>

RATE	FEE
BASIC FEE	740.00
X \$ 18 =	
X 84 =	
+280 =	
<b>TOTAL</b>	

\* If the difference in column 1 is less than zero, enter "0" in column 2

**CLAIMS AS AMENDED - PART II**

	(Column 1)	(Column 2)	(Column 3)
<b>AMENDMENT A</b>	CLAIMS REMAINING AFTER AMENDMENT		HIGHEST NUMBER PREVIOUSLY PAID FOR
	Total	* Minus	** =
	Independent	* Minus	*** =
	FIRST PRESENTATION OF MULTIPLE DEPENDENT CLAIM <input type="checkbox"/>		

**SMALL ENTITY** OR

**OTHER THAN SMALL ENTITY**

RATE	ADDITIONAL FEE
X \$ 9 =	
X 42 =	
+140 =	
<b>TOTAL ADDIT. FEE</b>	

RATE	ADDITIONAL FEE
X \$ 18 =	
X 84 =	
+280 =	
<b>TOTAL ADDIT. FEE</b>	

	(Column 1)	(Column 2)	(Column 3)
<b>AMENDMENT B</b>	CLAIMS REMAINING AFTER AMENDMENT		HIGHEST NUMBER PREVIOUSLY PAID FOR
	Total	* Minus	** =
	Independent	* Minus	*** =
	FIRST PRESENTATION OF MULTIPLE DEPENDENT CLAIM <input type="checkbox"/>		

RATE	ADDITIONAL FEE
X \$ 9 =	
X 42 =	
+140 =	
<b>TOTAL ADDIT. FEE</b>	

RATE	ADDITIONAL FEE
X \$ 18 =	
X 84 =	
+280 =	
<b>TOTAL ADDIT. FEE</b>	

	(Column 1)	(Column 2)	(Column 3)
<b>AMENDMENT C</b>	CLAIMS REMAINING AFTER AMENDMENT		HIGHEST NUMBER PREVIOUSLY PAID FOR
	Total	* Minus	** =
	Independent	* Minus	*** =
	FIRST PRESENTATION OF MULTIPLE DEPENDENT CLAIM <input type="checkbox"/>		

RATE	ADDITIONAL FEE
X \$ 9 =	
X 42 =	
+140 =	
<b>TOTAL ADDIT. FEE</b>	

RATE	ADDITIONAL FEE
X \$ 18 =	
X 84 =	
+280 =	
<b>TOTAL ADDIT. FEE</b>	

\* If the entry in column 1 is less than the entry in column 2, write "0" in column 3.

\*\* If the "Highest Number Previously Paid For" IN THIS SPACE is less than 20, enter "20."

\*\*\* If the "Highest Number Previously Paid For" IN THIS SPACE is less than 3, enter "3."

The "Highest Number Previously Paid For" (Total or Independent) is the highest number found in the appropriate box in column 1.

BEST AVAILABLE COPY




**UNITED STATES PATENT AND TRADEMARK OFFICE**

 COMMISSIONER FOR PATENTS  
 UNITED STATES PATENT AND TRADEMARK OFFICE  
 WASHINGTON, D.C. 20231  
 www.uspto.gov

APPLICATION NUMBER	FILING/RECEIPT DATE	FIRST NAMED APPLICANT	ATTORNEY DOCKET NUMBER
10/101,863	03/16/2002	Hongmei Zhang	M-12245 US

**CONFIRMATION NO. 6938**

 Skjerven Morrill Macpherson LLP  
 Suite 700  
 250 Metro Drive  
 San Jose, CA 95110

**FORMALITIES LETTER**


\*OC00000008148448\*

Date Mailed: 05/17/2002

**NOTICE TO FILE MISSING PARTS OF NONPROVISIONAL APPLICATION**
**FILED UNDER 37 CFR 1.53(b)**
*Filing Date Granted*
**Items Required To Avoid Abandonment:**

An application number and filing date have been accorded to this application. The item(s) indicated below, however, are missing. Applicant is given **TWO MONTHS** from the date of this Notice within which to file all required items and pay any fees required below to avoid abandonment. Extensions of time may be obtained by filing a petition accompanied by the extension fee under the provisions of 37 CFR 1.136(a).

- The statutory basic filing fee is missing.  
*Applicant must submit \$ 370 to complete the basic filing fee for a small entity.*
- The oath or declaration is unsigned.
- To avoid abandonment, a late filing fee or oath or declaration surcharge as set forth in 37 CFR 1.16(l) of \$65 for a small entity in compliance with 37 CFR 1.27, must be submitted with the missing items identified in this letter.

**Items Required To Avoid Processing Delays:**

The item(s) indicated below are also required and should be submitted with any reply to this notice to avoid further processing delays.

- Additional claim fees of **\$255** as a small entity, including any required multiple dependent claim fee, are required. Applicant must submit the additional claim fees or cancel the additional claims for which fees are due.

**SUMMARY OF FEES DUE:**


Total additional fee(s) required for this application is **\$690** for a Small Entity

- **\$370** Statutory basic filing fee.
- **\$65** Late oath or declaration Surcharge.
- Total additional claim fee(s) for this application is **\$255**
  - **\$171** for **19** total claims over 20.

- \$84 for 2 independent claims over 3.

---

*A copy of this notice **MUST** be returned with the reply.*

  
\_\_\_\_\_  
Customer Service Center  
Initial Patent Examination Division (703) 308-1202

PART 3 - OFFICE COPY



COPY OF PAPERS  
ORIGINALLY FILED

#3

UNITED STATES PATENT AND TRADEMARK OFFICE

COMMISSIONER FOR PATENTS  
UNITED STATES PATENT AND TRADEMARK OFFICE  
WASHINGTON, D.C. 20231  
www.uspto.gov

APPLICATION NUMBER	FILING/RECEIPT DATE	FIRST NAMED APPLICANT	ATTORNEY DOCKET NUMBER
10/101,863	03/16/2002	Hongmei Zhang	M-12245 US

CONFIRMATION NO. 6938

Skjerven Morrill Macpherson LLP  
Suite 700  
250 Metro Drive  
San Jose, CA 95110

FORMALITIES LETTER



\*OC00000008148448\*

Date Mailed: 05/17/2002

NOTICE TO FILE MISSING PARTS OF NONPROVISIONAL APPLICATION

FILED UNDER 37 CFR 1.53(b)

Filing Date Granted

Items Required To Avoid Abandonment:

An application number and filing date have been accorded to this application. The item(s) indicated below, however, are missing. Applicant is given **TWO MONTHS** from the date of this Notice within which to file all required items and pay any fees required below to avoid abandonment. Extensions of time may be obtained by filing a petition accompanied by the extension fee under the provisions of 37 CFR 1.136(a).

- The statutory basic filing fee is missing.  
*Applicant must submit \$ 370 to complete the basic filing fee for a small entity.*
- The oath or declaration is unsigned.
- To avoid abandonment, a late filing fee or oath or declaration surcharge as set forth in 37 CFR 1.16(l) of \$65 for a small entity in compliance with 37 CFR 1.27, must be submitted with the missing items identified in this letter.

Items Required To Avoid Processing Delays:

The item(s) indicated below are also required and should be submitted with any reply to this notice to avoid further processing delays.

- Additional claim fees of \$255 as a small entity, including any required multiple dependent claim fee, are required. Applicant must submit the additional claim fees or cancel the additional claims for which fees are due.

SUMMARY OF FEES DUE:

Total additional fee(s) required for this application is \$690 for a Small Entity

08/28/2002 MAHME1 00000073 192386 10101863

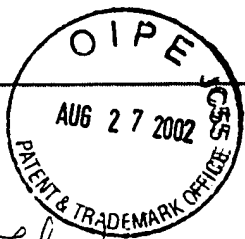
01 FC:201	370.00 CH
02 FC:202	84.00 CH
03 FC:203	171.00 CH
04 FC:205	65.00 CH

- \$370 Statutory basic filing fee.
- \$65 Late oath or declaration Surcharge.
- Total additional claim fee(s) for this application is \$255
  - \$171 for 19 total claims over 20.

BEST AVAILABLE COPY

COPY OF PAPERS  
ORIGINALLY FILED

- \$84 for 2 independent claims over 3.



*A copy of this notice **MUST** be returned with the reply.*

*Cludy*

Customer Service Center  
Initial Patent Examination Division (703) 308-1202

PART 2 - COPY TO BE RETURNED WITH RESPONSE

K3 TID MP# #3

IN THE UNITED STATES PATENT AND TRADEMARK OFFICE



Applicants: Hongmei Zhang, Mukundan Narasimhan, Ravi B. Mullapudi and Richard E. Demaray

Assignee: Symmorphix, Inc.

Title: Biased Pulse DC Reactive Sputtering Of Oxide Films

Serial No.: 10/101,863 Filing Date: March 16, 2002

Examiner: Unknown Group Art Unit: Unknown

Docket No.: M-12245 US

COPY OF PAPERS  
ORIGINALLY FILED

San Jose, California  
August 19, 2002

BOX MISSING PARTS  
COMMISSIONER FOR PATENTS  
Washington, D.C. 20231

RESPONSE TO NOTICE TO FILE MISSING PARTS OF NON-PROVISIONAL APPLICATION - FILING DATE GRANTED

Dear Sir:

In response to the "Notice to File Missing Parts of Non-Provisional Application - Filing Date Granted" mailed by the United States Patent and Trademark Office on May 17, 2002, the following documents are enclosed to complete the filing of the above-identified patent application:

1. A declaration signed by the inventors in compliance with 37 CFR 1.63;
2. Copy of Notice to File Missing Parts of Non-Provisional Application - Filing Date Granted; and
3. Petition for Extension of Time.

The United States Patent and Trademark Office is hereby authorized to charge the following fees to Deposit Account No. 19-2386:

- |  |         |
|--|---------|
| 1. Surcharge for filing declaration on a date later than the filing date of the application. | \$65.00 |
|--|---------|

LAW OFFICES OF  
SKJERVEN MORRILL LLP  
25 METRO DRIVE  
SUITE 700  
SAN JOSE, CA 95110  
(408) 453-9200  
FAX (408) 453-7979



COPY OF PAPERS  
ORIGINALLY FILED

2.	Statutory basic filing fee	\$370.00
3.	19 extra claims at \$9.00 each	\$171.00
4.	2 extra independent claims at \$42.00 each	\$84.00
5.	Petition for Extension of Time	\$55.00
6.	<b>TOTAL FEES:</b>	<b>\$745.00</b>

The Commissioner is hereby authorized to charge any additional fees, which may be required, or credit any overpayment to Deposit Account No. 19-2386.

It is hereby respectfully submitted that the enclosed documents complete the filing of the above patent application and justify the filing date of March 16, 2002. Please telephone the undersigned at (408) 453-9200, if there are any questions. This form is being submitted in duplicate.

I hereby certify that this correspondence is being deposited with the United States Postal Service as First Class Mail in an envelope addressed to: Box Missing Parts, Commissioner for Patents, Washington, D.C. 20231, on August 19, 2002.

*Gary J. Edwards*  
 Attorney for Applicants

*8/19/02*  
 Date of Signature

Respectfully submitted,  
*Gary J. Edwards*  
 Gary J. Edwards  
 Attorney for Applicant  
 Reg. No. 41,008

LAW OFFICES OF  
 SKJERVEN MORRILL LLP  
 25 METRO DRIVE  
 SUITE 700  
 SAN JOSE, CA 95110  
 (408) 453-9200  
 FAX (408) 453-7979

# 3

Aug-08-2002 16:53

From: SKJERVEN, MORRILL, LLP

+4084537978

T-529 P.006/011 F-572



COPY OF PAPERS  
ORIGINALLY FILED

Attorney Docket No.: M-12245 US

**DECLARATION FOR PATENT APPLICATION  
AND POWER OF ATTORNEY**

As a below named inventor, I hereby declare that:

My residence, post office address and citizenship are as stated below adjacent to my name.

I believe I am the original, first and sole inventor (if only one name is listed below) or an original, first and joint inventor (if plural names are listed below) of subject matter (process, machine, manufacture, or composition of matter, or an improvement thereof) which is claimed and for which a patent is sought by way of the application entitled

**Biased Pulse DC Reactive Sputtering of Oxide Films**

- which (check)
- is attached hereto.
  - and is amended by the Preliminary Amendment attached hereto.
  - was filed on March 16, 2002 as Application Serial No. 10/101,863.
  - and was amended on (if applicable).

I hereby state that I have reviewed and understand the contents of the above identified specification, including the claims, as amended by any amendment referred to above.

I acknowledge the duty to disclose information, which is material to patentability as defined in Title 37, Code of Federal Regulations, § 1.56.

I hereby claim foreign priority benefits under Title 35, United States Code, § 119(a) (d) of any foreign application(s) for patent or inventor's certificate or any PCT international application(s) designating at least one country other than the United States of America listed below and have also identified below any foreign application(s) for patent or inventor's certificate or any PCT international application(s) designating at least one country other than the United States of America filed by me on the same subject matter having a filing date before that of the application(s) of which priority is claimed:

Number	Prior Foreign Application(s)		Priority Claimed	
	Country	Day/Month/Year Filed	Yes	No
N/A			<input type="checkbox"/>	<input type="checkbox"/>

I hereby claim the benefit under Title 35, United States Code, § 119(e) of any United States provisional application(s) listed below:

Provisional Application Number	Filing Date
N/A	

I hereby claim the benefit under Title 35, United States Code, § 120 of any United States application(s) or PCT international application(s) designating the United States of America listed below and, insofar as the subject matter of each of the claims of this application is not disclosed in the prior application(s) in the manner provided by the first paragraph of Title 35, United States Code, § 112, I acknowledge the duty to disclose information, which is material to patentability as defined in Title 37, Code of Federal Regulations, § 1.56, which became available between the filing date of the prior application(s) and the national or PCT international filing date of this application:

Application Serial No.	Filing Date	Status (patented, pending, abandoned)
N/A		

BEST AVAILABLE COPY



From SKJERVEN, MORRILL, LLP

+4084537978

T-523 P.007/011 F-372

Attorney Docket No.: M-12245 US

I hereby appoint the following practitioners to prosecute this application and to transact all business in the United States Patent and Trademark Office connected therewith:

Customer Number 24251



COPY OF PAPERS  
ORIGINALLY FILED

Please direct all telephone calls to:

Gary J. Edwards

Telephone: 408-453-9200

I declare that all statements made herein of my own knowledge are true, all statements made herein on information and belief are believed to be true, and all statements made herein are made with the knowledge that whoever, in any matter within the jurisdiction of the Patent and Trademark Office, knowingly and willfully falsifies, conceals, or covers up by any trick, scheme, or device a material fact, or makes any false, fictitious or fraudulent statements or representations, or makes or uses any false writing or document knowing the same to contain any false, fictitious or fraudulent statement or entry, shall be subject to the penalties including fine or imprisonment or both as set forth under 18 U.S.C. 1001 and that violations of this paragraph may jeopardize the validity of the application or this document, or the validity or enforceability of any patent, trademark registration, or certificate resulting therefrom.

Full name of first joint inventor: Hongmei Zhang  
Inventor's Signature: [Signature] Date: 08/08/02  
Residence: San Jose, California  
Post Office Address: 1330 Rodney Drive San Jose, California 95118  
Citizenship: People of Republic China

Full name of second joint inventor: Mukundan Narasimhan  
Inventor's Signature: [Signature] Date: 08/08/02  
Residence: San Jose, California  
Post Office Address: 293 Bluefield Drive San Jose, California 95136  
Citizenship:

Full name of third joint inventor: Ravi B. Mullanpudi  
Inventor's Signature: [Signature] Date: 08/08/02  
Residence: San Jose, California  
Post Office Address: 2117 Shiangzone Court San Jose, California 95121  
Citizenship: India

Full name of fourth joint inventor: Richard E. Demaray  
Inventor's Signature: [Signature] Date: 8/8/02  
Residence: Portola Valley, California  
Post Office Address: 190 Fawn Lane Portola Valley, California 94028  
Citizenship: USA

BEST AVAILABLE COPY





COPY OF PAPERS  
ORIGINALLY FILED

#4

IN THE UNITED STATES PATENT AND TRADEMARK OFFICE

Applicants: Hongmei Zhang, Mukundan Narasimhan, Ravi B. Mullapudi and Richard E. Demaray

Assignee: Symmorphix, Inc.

Title: Biased Pulse DC Reactive Sputtering Of Oxide Films

Serial No.: 10/101,863                      Filing Date: March 16, 2002

Examiner: Unknown                      Group Art Unit: Unknown

Docket No.: M-12245 US

San Jose, California  
August 19, 2002

BOX Missing Parts  
COMMISSIONER FOR PATENTS  
Washington, D. C. 20231

**PETITION FOR EXTENSION OF TIME**

Dear Sir:

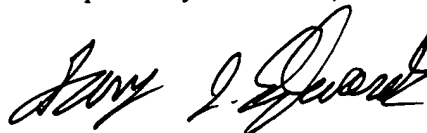
Applicants respectfully petition for a 1-month extension of time within which to respond to the May 17, 2002 outstanding Notice to File Missing Parts, such extension allowing the undersigned until August 19, 2002 (as August 17, 2002 is a Saturday) to respond.

Please charge the amount of \$55.00 as set forth in the enclosed Response to Notice to File Missing Parts.

I hereby certify that this correspondence is being deposited with the United States Postal Service as First Class Mail in an envelope addressed to: Box Missing Parts, Commissioner for Patents, Washington, D.C. 20231, on August 19, 2002.

      8/19/02  
 Attorney for Applicants      Date of Signature

Respectfully submitted,



Gary J. Edwards  
Attorney for Applicants  
Reg. No. 41,008

LAW OFFICES OF  
SKJERVEN MORRILL LLP  
25 METRO DRIVE  
SUITE 700  
SAN JOSE, CA 95110  
(408) 453-9200  
FAX (408) 453-7979

08/29/2002 MAHME1 0000073 192385 10101863

05 00:215 55.00 14

888511 vl

-1-

Serial No.: 10/101,863

BEST AVAILABLE COPY

8



UNITED STATES PATENT AND TRADEMARK OFFICE

UNITED STATES DEPARTMENT OF COMMERCE  
United States Patent and Trademark Office  
Address: COMMISSIONER FOR PATENTS  
P.O. Box 1450  
Alexandria, Virginia 22313-1450  
www.uspto.gov

APPLICATION NO.	FILING DATE	FIRST NAMED INVENTOR	ATTORNEY DOCKET NO.	CONFIRMATION NO.
10/101,863	03/16/2002	Hongmei Zhang	M-12245 US	6938

7590 10/02/2003  
Skjerven Morrill Macpherson LLP  
Suite 700  
250 Metro Drive  
San Jose, CA 95110

EXAMINER

ESTRADA, MICHELLE

ART UNIT PAPER NUMBER

2823

DATE MAILED: 10/02/2003

Please find below and/or attached an Office communication concerning this application or proceeding.

**Office Action Summary**

Application No.

10/101,863

Applicant(s)

ZHANG ET AL.

Examiner

Michelle Estrada

Art Unit

2823

-- The MAILING DATE of this communication appears on the cover sheet with the correspondence address --

**Period for Reply**

A SHORTENED STATUTORY PERIOD FOR REPLY IS SET TO EXPIRE 1 MONTH(S) FROM THE MAILING DATE OF THIS COMMUNICATION.

- Extensions of time may be available under the provisions of 37 CFR 1.136(a). In no event, however, may a reply be timely filed after SIX (6) MONTHS from the mailing date of this communication.
- If the period for reply specified above is less than thirty (30) days, a reply within the statutory minimum of thirty (30) days will be considered timely.
- If NO period for reply is specified above, the maximum statutory period will apply and will expire SIX (6) MONTHS from the mailing date of this communication.
- Failure to reply within the set or extended period for reply will, by statute, cause the application to become ABANDONED (35 U.S.C. § 133).
- Any reply received by the Office later than three months after the mailing date of this communication, even if timely filed, may reduce any earned patent term adjustment. See 37 CFR 1.704(b).

**Status**

- 1)  Responsive to communication(s) filed on \_\_\_\_\_ .
- 2a)  This action is **FINAL**.                      2b)  This action is non-final.
- 3)  Since this application is in condition for allowance except for formal matters, prosecution as to the merits is closed in accordance with the practice under *Ex parte Quayle*, 1935 C.D. 11, 453 O.G. 213.

**Disposition of Claims**

- 4)  Claim(s) 1-39 is/are pending in the application.
- 4a) Of the above claim(s) \_\_\_\_\_ is/are withdrawn from consideration.
- 5)  Claim(s) \_\_\_\_\_ is/are allowed.
- 6)  Claim(s) \_\_\_\_\_ is/are rejected.
- 7)  Claim(s) \_\_\_\_\_ is/are objected to.
- 8)  Claim(s) 1-39 are subject to restriction and/or election requirement.

**Application Papers**

- 9)  The specification is objected to by the Examiner.
- 10)  The drawing(s) filed on \_\_\_\_\_ is/are: a)  accepted or b)  objected to by the Examiner.  
Applicant may not request that any objection to the drawing(s) be held in abeyance. See 37 CFR 1.85(a).
- 11)  The proposed drawing correction filed on \_\_\_\_\_ is: a)  approved b)  disapproved by the Examiner.  
If approved, corrected drawings are required in reply to this Office action.
- 12)  The oath or declaration is objected to by the Examiner.

**Priority under 35 U.S.C. §§ 119 and 120**

- 13)  Acknowledgment is made of a claim for foreign priority under 35 U.S.C. § 119(a)-(d) or (f).  
a)  All   b)  Some \*   c)  None of:  
1.  Certified copies of the priority documents have been received.  
2.  Certified copies of the priority documents have been received in Application No. \_\_\_\_\_ .  
3.  Copies of the certified copies of the priority documents have been received in this National Stage application from the International Bureau (PCT Rule 17.2(a)).  
\* See the attached detailed Office action for a list of the certified copies not received.
- 14)  Acknowledgment is made of a claim for domestic priority under 35 U.S.C. § 119(e) (to a provisional application).  
a)  The translation of the foreign language provisional application has been received.
- 15)  Acknowledgment is made of a claim for domestic priority under 35 U.S.C. §§ 120 and/or 121.

**Attachment(s)**

- 1)  Notice of References Cited (PTO-892)
- 2)  Notice of Draftsperson's Patent Drawing Review (PTO-948)
- 3)  Information Disclosure Statement(s) (PTO-1449) Paper No(s) \_\_\_\_\_ .
- 4)  Interview Summary (PTO-413) Paper No(s). \_\_\_\_\_ .
- 5)  Notice of Informal Patent Application (PTO-152)
- 6)  Other: \_\_\_\_\_ .

**DETAILED ACTION**

***Election/Restrictions***

- I. Claims 1-14 and 20-24, drawn to a coating method, classified in class 427, subclass 1+.
- II. Claims 15-19 and 38-39, drawn to a coating apparatus, classified in class 118, subclass 1+.
- III. Claims 25-37, drawn to a process of making a semiconductor device, classified in class 438, subclass 761.

Inventions I and II are related as process and apparatus for its practice. The inventions are distinct if it can be shown that either: (1) the process as claimed can be practiced by another materially different apparatus or by hand, or (2) the apparatus as claimed can be used to practice another and materially different process. (MPEP § 806.05(e)). In this case the apparatus as claimed can be used to practice another and materially different process such as one that does not require providing a process gas between the target and the substrate.

Inventions I and III are related as combination and subcombination. Inventions in this relationship are distinct if it can be shown that (1) the combination as claimed does not require the particulars of the subcombination as claimed for patentability, and (2) that the subcombination has utility by itself or in other combinations (MPEP § 806.05(c)). In the instant case, the combination as claimed does not require the particulars of the subcombination as claimed because the combination does not require providing an undercladding layer, patterning the film to form a core and depositing an

Art Unit: 2823

uppercladding layer over the core. The subcombination has separate utility such as a waveguide amplifier to use in semiconductor devices.

For Making  
^

Inventions II and III are related as process and apparatus for its practice. The inventions are distinct if it can be shown that either: (1) the process as claimed can be practiced by another materially different apparatus or by hand, or (2) the apparatus as claimed can be used to practice another and materially different process. (MPEP § 806.05(e)). In this case the apparatus as claimed can be used to practice another and materially different process such as one that does not require providing an undercladding layer and an uppercladding layer.

Applicant is reminded that upon the cancellation of claims to a non-elected invention, the inventorship must be amended in compliance with 37 CFR 1.48(b) if one or more of the currently named inventors is no longer an inventor of at least one claim remaining in the application. Any amendment of inventorship must be accompanied by a request under 37 CFR 1.48(b) and by the fee required under 37 CFR 1.17(i).

Any inquiry concerning this communication or earlier communications from the examiner should be directed to Michelle Estrada whose telephone number is (703) 308-0729. The examiner can normally be reached on Monday through Friday.


If attempts to reach the examiner by telephone are unsuccessful, the examiner's supervisor, Olik Chaudhuri can be reached on 703-306-2794. The fax phone numbers

Application/Control Number: 10/101,863  
Art Unit: 2823

Page 4

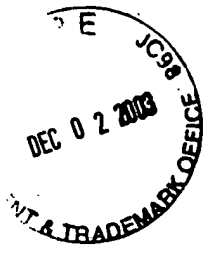
for the organization where this application or proceeding is assigned are 703-308-7722 for regular communications and 703-308-7724 for After Final communications.

Any inquiry of a general nature or relating to the status of this application or proceeding should be directed to the receptionist whose telephone number is 703-308-0956.

  
George Fourson  
Primary Examiner  
Art Unit 2823

  
MEstrada  
September 28, 2003

41



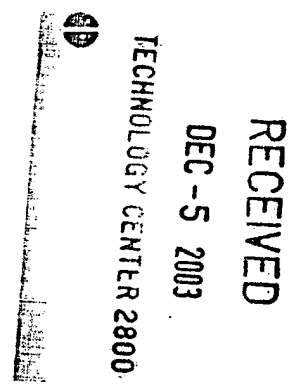
PATENT  
Customer No. 22,852  
Attorney Docket No. 09140.0016  
(formerly M-12245 US)

IN THE UNITED STATES PATENT AND TRADEMARK OFFICE

In re Application of:	)	
	)	
Zhang, et al.	)	Group Art Unit: 2816
	)	
Application No.: 10/101,863	)	Examiner: Unassigned
	)	
Filed: March 16, 2002	)	
	)	
For: BIASED PULSE DC REACTIVE	)	
SPUTTERING OF OXIDE FILMS	)	
	)	

Commissioner for Patents  
Washington, DC 20231

Sir:



**REVOCATION OF POWER OF ATTORNEY  
AND GRANT OF NEW POWER OF ATTORNEY**

The undersigned, a representative authorized to sign on behalf of the Assignee owning all of the interest in this patent, hereby revokes all previous powers of attorney or authorization of agent granted in this application before the date of execution hereof. The undersigned verifies that Symmorphix, Inc. is the Assignee of the entire right, title, and interest in the patent application identified above by virtue of the attached assignment document, which is being concurrently filed for recordation. The undersigned certifies that the evidentiary documents have been reviewed and to the best of the undersigned's knowledge and belief, title is in the Assignee Symmorphix, Inc.

The undersigned hereby grants its power of attorney to **FINNEGAN, HENDERSON, FARABOW, GARRETT & DUNNER, L.L.P.**, Douglas B. Henderson, Reg. No. 20,291; Ford F. Farabow, Jr., Reg. No. 20,630; Arthur S. Garrett, Reg. No. 20,338; Donald R. Dunner, Reg. No. 19,073; Brian G. Brunsvold, Reg. No. 22,593; Tipton D. Jennings, IV, Reg. No. 20,645; Jerry D. Voight, Reg. No. 23,020; Laurence R. Hefter, Reg. No. 20,827; Kenneth E. Payne, Reg. No. 23,098; Herbert H. Mintz, Reg. No. 26,691; C. Larry O'Rourke, Reg. No. 26,014; Albert J. Santorelli, Reg. No. 22,610; Michael C. Elmer, Reg. No. 25,857; Richard H. Smith, Reg. No. 20,609; Stephen L. Peterson, Reg. No. 26,325; John M. Romary, Reg. No. 26,331; Bruce C. Zotter, Reg. No. 27,680; Dennis P. O'Reilley, Reg. No. 27,932; Allen M. Sokal, Reg. No. 26,695; Robert D. Bajefsky, Reg. No. 25,387; Richard L. Stroup, Reg. No. 28,478; David W. Hill, Reg. No. 28,220; Thomas L. Irving, Reg. No. 28,619; Charles E. Lipsey, Reg. No. 28,165; Thomas W. Winland, Reg. No. 27,605; Basil J. Lewris, Reg. No. 28,818; Martin I. Fuchs, Reg. No. 28,508; E. Robert Yoches, Reg. No. 30,120; Barry W. Graham, Reg. No. 29,924; Susan Haberman Griffen, Reg. No. 30,907; Richard B. Racine, Reg. No. 30,415; Thomas H. Jenkins, Reg. No. 30,857; Robert E. Converse, Jr., Reg. No. 27,432; Clair X. Mullen, Jr., Reg. No. 20,348; Christopher P. Foley, Reg. No. 31,354; Roger D. Taylor, Reg. No. 28,992; John C. Paul, Reg. No. 30,413; David M. Kelly, Reg. No. 30,953; Kenneth J. Meyers, Reg. No. 25,146; Carol P. Einaudi, Reg. No. 32,220; Walter Y. Boyd, Jr., Reg. No. 31,738; Steven M. Anzalone, Reg. No. 32,095; Jean B. Fordis, Reg. No. 32,984; Barbara C. McCurdy, Reg. No. 32,120; James K. Hammond, Reg. No. 31,964; Richard V. Burgujian, Reg. No. 31,744; J. Michael Jakes, Reg. No. 32,824; Thomas W. Banks, Reg. No. 32,719; Christopher P. Isaac, Reg. No. 32,616; Bryan C. Diner, Reg. No. 32,409; M. Paul Barker, Reg. No. 32,013; Andrew Chanho Sonu, Reg. No. 33,457; David S. Forman, Reg. No. 33,694; Vincent P. Kovalick, Reg. No. 32,867; James W.

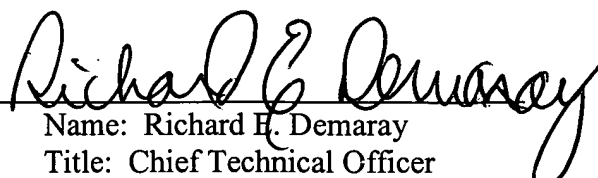


Edmondson, Reg. No. 33,871; Michael R. McGurk, Reg. No. 32,045; Joann M. Neth, Reg. No. 36,363; Gerson S. Panitch, Reg. No. 33,751; Cheri M. Taylor, Reg. No. 33,216; Charles E. Van Horn, Reg. No. 40,266; Linda A. Wadler, Reg. No. 33,218; Jeffrey A. Berkowitz, Reg. No. 36,743; Michael R. Kelly, Reg. No. 33, 921; James B. Monroe, Reg. No. 33,971; Doris Johnson Hines, Reg. No. 34,629; Lori Ann Johnson, Reg. No. 34,498; R. Bruce Bower, Reg. No. 37,099; John Rissman, Reg. No. 33,764; Therese A. Hendricks, Reg. No. 30,389; Leslie I. Bookoff, Reg. No. 38,084; Michele C. Bosch, Reg. No. 40,524; Michael J. Flibbert, Reg. No. 33,234; Scott A. Herbst, Reg. No. 35,189; Leslie A. McDonell, Reg. No. 34,872; Thalia V. Warnement, Reg. No. 39,064; Ronald A. Bleeker, Reg. No. 27,773; Kathleen A. Daley, Reg. No. 36,116; C. Gregory Gramenopoulos, Reg. No. 36,532; Anthony M. Gutowski, Reg. No. 38,742; Yitai Hu, Reg. No. 40,653; Lionel M. Lavenue; Reg. No. 46,859; Christine E. Lehman, Reg. No. 38,535; and Gary J. Edwards, Reg. No. 41,008; both jointly and separately as their attorneys with full power of substitution and revocation to prosecute this application and to transact all business in the Patent and Trademark Office connected therewith, and to receive the Letters Patent.

Please send all future correspondence concerning this application to Finnegan, Henderson, Farabow, Garrett & Dunner, L.L.P. at the following address:

Finnegan, Henderson, Farabow,  
Garrett & Dunner, L.L.P.  
1300 I Street, N.W.  
Washington, D.C. 20005-3315

Dated: Nov 18, 2003

By:   
Name: Richard H. Demaray  
Title: Chief Technical Officer  
Symmorphix, Inc.

**ASSIGNMENT**

WHEREAS WE, the below named inventors, [hereinafter referred to as Assignor], have made an invention entitled:

**BIASED PULSE DC REACTIVE SPUTTERING OF OXIDE FILMS**

for which we executed an application for United States Letters Patent concurrently herewith or filed an application for United States Letters Patent March 16, 2002, (Application No. 10/101,863); and

WHEREAS, SYMMORPHIX, INC., a corporation of Delaware, whose post office address is 1278 Reamwood Avenue, Sunnyvale, CA 94089-2233 (hereinafter referred to as Assignee), is desirous of securing the entire right, title, and interest in and to this invention in all countries throughout the world, and in and to the application for United States Letters Patent on this invention and the Letters Patent to be issued upon this application;

NOW THEREFORE, be it known that for good and valuable consideration the receipt of which from Assignee is hereby acknowledged, we, as Assignors, have sold, assigned, transferred, and set over, and do hereby sell, assign, transfer, and set over unto the Assignee, its lawful successors and assigns, my entire right, title, and interest in and to this invention; and this application, Application No. 10/101,863, filed March 16, 2002; and all divisions, and continuations thereof, and all Letters Patent of the United States which may be granted thereon, and all reissues thereof, and all rights to claim priority on the basis of this application, Application No. 10/101,863, filed March 16, 2002, and all applications for Letters Patent which may hereafter be filed for this invention in any foreign country and all Letters Patent which may be granted on this invention in any foreign country, and all extensions, renewals, and reissues thereof; and we hereby authorize and request the Commissioner of Patents and Trademarks of the United States and any official of any foreign country whose duty it is to issue patents on applications as described above, to issue all Letters Patent for this invention to Assignee, its successors and assigns, in accordance with the terms of this Assignment;

AND, WE HEREBY covenant that we have the full right to convey the interest assigned by this Assignment, and we have not executed and will not execute any agreement in conflict with this Assignment;

AND, WE HEREBY further covenant and agree that we will, without further consideration, communicate with Assignee, its successors and assigns, any facts known to us respecting this invention, and testify in any legal proceeding, sign all lawful papers when called upon to do so, execute and deliver any and all papers that may be necessary or desirable to perfect the title to this invention in said Assignee, its successors or assigns, execute all divisional, continuation, and reissue applications, make all rightful oaths and generally do everything possible to aid Assignee, its successors and assigns, to obtain and enforce proper patent protection for this invention in the United States and any foreign country, it being understood that any expense incident to the execution of such papers shall be borne by the Assignee, its successors and assigns.

IN TESTIMONY WHEREOF, we have hereunto set our hands.

State of CALIFORNIA )  
County of SANTA CLARA ) ss.

NAME: Hongmei Zhang  
ADDRESS: 1330 Rodney Drive  
San Jose, CA 95118



BY: Hongmei Zhang  
Hongmei Zhang

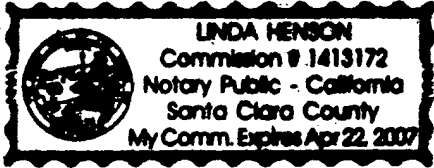
DATE: 6/18/2003

Subscribed and sworn to before me this 18<sup>th</sup> day of June, 2003.

Linda Henson Notary Public

State of CALIFORNIA  
County of SANTA CLARA ss.

NAME: Mukundan Narasimhan  
ADDRESS: 293 Bluefield Drive  
San Jose, CA 95136



BY: N. Narasimhan  
Mukundan Narasimhan

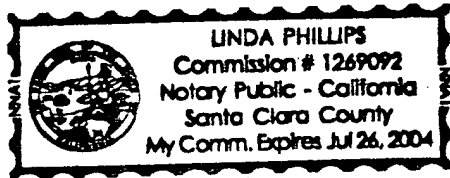
DATE: 06/18/03

Subscribed and sworn to before me this 18<sup>th</sup> day of June, 2003.

Linda Henson, Notary Public

State of CALIFORNIA  
County of SANTA CLARA ss.

NAME: Ravi B. Mullapudi  
ADDRESS: 2117 Shiangzone Court  
San Jose, CA 95121



BY: R. Mullapudi  
Ravi B. Mullapudi

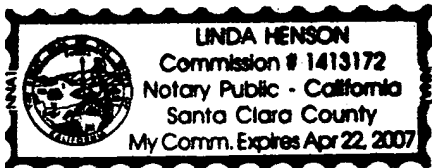
DATE: 10/27/03

Subscribed and sworn to before me this 27 day of October, 2003.

Linda Phillips, Notary Public

State of CALIFORNIA  
County of SANTA CLARA ss.

NAME: Richard E. Demaray  
ADDRESS: 190 Fawn Lane  
Portola Valley, CA 94028



BY: Richard E. Demaray  
Richard E. Demaray

DATE: June 18 2003

Subscribed and sworn to before me this 18<sup>th</sup> day of June, 2003.

Linda Henson, Notary Public

41

12-05-03

28/23  
#



PATENT  
Customer No. 22,852  
Attorney Docket No. 09140.0016-00000

**IN THE UNITED STATES PATENT AND TRADEMARK OFFICE**

In re Application of:	)	
	)	
Hongmei Zhang	)	Group Art Unit: 2823
	)	
Serial No.: 10/101,863	)	Examiner: Michelle Estrada
	)	
Filed: March 16, 2002	)	
	)	
For: BIASED PULSE DC REACTIVE	)	
SPUTTERING OF OXIDE FILMS	)	

Commissioner for Patents  
P.O. Box 1450  
Alexandria, VA 22313-1450

Sir:

RECEIVED  
DEC 11 2003  
TECHNOLOGY CENTER 2800

**RESPONSE TO RESTRICTION REQUIREMENT**

In a restriction requirement dated October 2, 2003, the Examiner required restriction under 35 U.S.C. § 121 between Group I (Claims 1-14 and 20-24, drawn to a coating method, classified in class 427, subclass 1+), Group II (Claims 15-19 and 38-39, drawn to a coating apparatus, classified in class 118, subclass 1+), and Group III (Claims 25-37, drawn to a process of making a semiconductor device, classified in class 438, subclass 761.) Applicants provisionally elect to prosecute **Group I**, claims 1-14 and 20-24 drawn to a coating method.

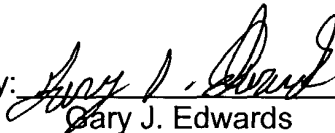
Please grant a one-month extension of time required to enter this response and charge the required small entity extension fee of \$55.00 under 37 C.F.R. 1.17(a)(1) to the deposit account No. 06-0916. Petition for 1-month Extension of Time is being filed concurrently.

If there is any additional fee due in connection with the filing of this Response,  
please charge the fee to our Deposit Account No. 06-0916.

Respectfully submitted,

FINNEGAN, HENDERSON, FARABOW,  
GARRETT & DUNNER, L.L.P.

Dated: December 2, 2003

By:   
Gary J. Edwards  
Reg. No. 41,008

CERTIFICATE UNDER 37 CFR § 1.10 OF  
MAILING BY "EXPRESS MAIL"

EL 974556529 US  
USPS Express Mail Label Number

December 2, 2003  
Date of Deposit

I hereby certify that this correspondence is being deposited with the United States  
Postal Services "Express Mail Post Office to Addressee" service under 37 CFR § 1.10  
on the date indicated above and is addressed to the Commissioner for Patents, P.O.  
Box 1450, Alexandria, VA 22313-1450.

By:   
Veronica Weinstein



PATENT  
Customer No. 22,852  
Attorney Docket No. 09140.0016-00000

**IN THE UNITED STATES PATENT AND TRADEMARK OFFICE**

In re Application of: )  
 )  
Hongmei Zhang ) Group Art Unit: 2823  
 )  
Application No.: 10/101,863 ) Examiner: Michelle Estrada  
 )  
Filed: March 16, 2002 )  
 )  
For: BIASED PULSE DC REACTIVE )  
SPUTTERING OF OXIDE FILMS )

RECEIVED  
DEC 11 2003  
TECHNOLOGY CENTER 2800

Commissioner for Patents  
P.O. Box 1450  
Alexandria, VA 22313-1450

Sir:

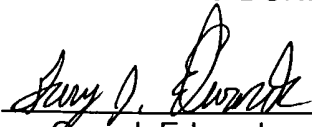
**PETITION FOR EXTENSION OF TIME**

Applicants hereby petition for a one month extension of time to reply to the Office Action of October 2, 2003. This Petition is accompanied by a small entity extension fee of \$55.00 as specified by Section 1.17(a)(1). Please charge \$55.00 to Deposit Account No. 06-0916.

Please grant any extensions of time required to enter the accompanying response and charge any additional required fees to our deposit account 06-0916.

Respectfully submitted,

FINNEGAN, HENDERSON, FARABOW,  
GARRETT & DUNNER, L.L.P.

By:   
Gary J. Edwards  
Reg. No. 41,008

Dated: December 2, 2003

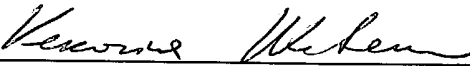
12/08/2003 HGUTEHA1 00000005 060916 10101863  
01 FC:2251 55.00 DA

CERTIFICATE UNDER 37 CFR § 1.10 OF  
MAILING BY "EXPRESS MAIL"

EL 974556529 US  
USPS Express Mail Label Number

December 2, 2003  
Date of Deposit

I hereby certify that this correspondence is being deposited with the United States Postal Services "Express Mail Post Office to Addressee" service under 37 CFR § 1.10 on the date indicated above and is addressed to the Commissioner for Patents, P.O. Box 1450, Alexandria, VA 22313-1450.

By:   
Veronica Weinstein

L Number	Hits	Search Text	DB	Time stamp
1	1	(target with "metallic mode") and (target with "poisonous")	USPAT; US-PGPUB	2004/02/12 13:34
-	41231	"DC power"	USPAT; US-PGPUB	2004/02/11 10:13
-	16262	bias with substrate	USPAT; US-PGPUB	2004/02/11 10:13
-	995	"DC power" with target	USPAT; US-PGPUB	2004/02/11 10:14
-	322	((bias with substrate) and ("DC power" with target)) not (@ad>20020316 or @rlad>20020316)	USPAT; US-PGPUB	2004/02/11 10:23
-	0	((bias with substrate) and ("DC power" with target)) not (@ad>20020316 or @rlad>20020316) and ("DC pwer" with filter)	USPAT; US-PGPUB	2004/02/11 10:23
-	20	((bias with substrate) and ("DC power" with target)) not (@ad>20020316 or @rlad>20020316) and ("DC power" with filter)	USPAT; US-PGPUB	2004/02/11 10:35
-	197	438/769.ccls.	USPAT; US-PGPUB	2004/02/11 10:35
-	0	((bias with substrate) and ("DC power" with target)) and 438/769.ccls.	USPAT; US-PGPUB	2004/02/11 10:35
-	611	438/787.ccls.	USPAT; US-PGPUB	2004/02/11 10:36
-	2	((bias with substrate) and ("DC power" with target)) and 438/787.ccls.	USPAT; US-PGPUB	2004/02/11 10:36
-	453	438/770.ccls.	USPAT; US-PGPUB	2004/02/11 10:36
-	0	((bias with substrate) and ("DC power" with target)) and 438/770.ccls.	USPAT; US-PGPUB	2004/02/11 10:36
-	89	438/771.ccls.	USPAT; US-PGPUB	2004/02/11 10:36
-	0	((bias with substrate) and ("DC power" with target)) and 438/771.ccls.	USPAT; US-PGPUB	2004/02/11 10:36
-	443	438/788.ccls.	USPAT; US-PGPUB	2004/02/11 10:37
-	1	((bias with substrate) and ("DC power" with target)) and 438/788.ccls.	USPAT; US-PGPUB	2004/02/11 10:37
-	242	427/533.ccls.	USPAT; US-PGPUB	2004/02/11 10:37
-	1	((bias with substrate) and ("DC power" with target)) and 427/533.ccls.	USPAT; US-PGPUB	2004/02/11 10:37
-	89227	427/\$.ccls.	USPAT; US-PGPUB	2004/02/11 10:38
-	33	((bias with substrate) and ("DC power" with target)) and 427/\$.ccls.	USPAT; US-PGPUB	2004/02/11 10:38
-	30	((bias with substrate) and ("DC power" with target)) and 427/\$.ccls.) not (@ad>20020316 or @rlad>20020316)	USPAT; US-PGPUB	2004/02/11 10:40
-	74451	438/\$.ccls.	USPAT; US-PGPUB	2004/02/11 10:40
-	107	((bias with substrate) and ("DC power" with target)) and 438/\$.ccls.	USPAT; US-PGPUB	2004/02/11 10:40
-	87	((bias with substrate) and ("DC power" with target)) and 438/\$.ccls.) not (@ad>20020316 or @rlad>20020316)	USPAT; US-PGPUB	2004/02/11 10:40
-	1466	204/192.12.ccls.	USPAT; US-PGPUB	2004/02/11 11:40
-	98	((bias with substrate) and ("DC power" with target)) and 204/192.12.ccls.	USPAT; US-PGPUB	2004/02/11 11:38
-	89	((bias with substrate) and ("DC power" with target)) and 204/192.12.ccls.) not (@ad>20020316 or @rlad>20020316)	USPAT; US-PGPUB	2004/02/11 11:38
-	19	((bias with substrate) and ("DC power" with target)) and 204/192.12.ccls.) not (@ad>20020316 or @rlad>20020316) and filter	USPAT; US-PGPUB	2004/02/11 11:39



-	8	(((bias with substrate) and ("DC power" with target)) and 204/192.12.ccls.) not (@ad>20020316 or @rlad>20020316)) and filter) and (oxide or oxynitride)	USPAT; US-PGPUB	2004/02/11 11:39
-	1572	204/192.15.ccls.	USPAT; US-PGPUB	2004/02/11 11:40
-	68	((bias with substrate) and ("DC power" with target)) and 204/192.15.ccls.	USPAT; US-PGPUB	2004/02/11 11:41
-	43	(((bias with substrate) and ("DC power" with target)) and 204/192.15.ccls.) and (oxide or oxynitride)	USPAT; US-PGPUB	2004/02/11 11:41
-	39	(((bias with substrate) and ("DC power" with target)) and 204/192.15.ccls.) and (oxide or oxynitride)) not (@ad>20020316 or @rlad>20020316)	USPAT; US-PGPUB	2004/02/11 16:23
-	4	(((bias with substrate) and ("DC power" with target)) and 204/192.15.ccls.) and (oxide or oxynitride)) not (@ad>20020316 or @rlad>20020316)) and filter	USPAT; US-PGPUB	2004/02/11 11:44
-	56595	filter with band	USPAT; US-PGPUB	2004/02/11 16:23
-	365	(bias with substrate) and ("DC power" with target)	USPAT; US-PGPUB	2004/02/11 16:31
-	7	(filter with band) and ((bias with substrate) and ("DC power" with target))	USPAT; US-PGPUB	2004/02/11 16:26
-	6	((bias with substrate) and ("DC power" with target)) and "cladding layer"	USPAT; US-PGPUB	2004/02/11 16:28
-	2007	(deposit\$3 with "cladding layer")	USPAT; US-PGPUB	2004/02/11 16:29
-	0	((bias with substrate) and ("DC power" with target)) with (deposit\$3 with "cladding layer")	USPAT; US-PGPUB	2004/02/11 16:30
-	0	((bias with substrate) and ("DC power" with target)) same (deposit\$3 with "cladding layer")	USPAT; US-PGPUB	2004/02/11 16:30
-	5	((bias with substrate) and ("DC power" with target)) and (deposit\$3 with "cladding layer")	USPAT; US-PGPUB	2004/02/11 16:30
-	197	((bias with substrate) and ("DC power" with target)) and nitrogen	USPAT; US-PGPUB	2004/02/11 16:32
-	559562	oxide or oxynitride	USPAT; US-PGPUB	2004/02/11 16:32
-	140	(((bias with substrate) and ("DC power" with target)) and nitrogen) and (oxide or oxynitride)	USPAT; US-PGPUB	2004/02/11 17:14
-	3362	target with "magnetic field"	USPAT; US-PGPUB	2004/02/11 16:38
-	107	((bias with substrate) and ("DC power" with target)) and (target with "magnetic field")	USPAT; US-PGPUB	2004/02/11 16:40
-	21	deposit\$3 with (backside with target)	USPAT; US-PGPUB	2004/02/12 12:12
-	5	((bias with substrate) and ("DC power" with target)) and (deposit\$3 with (backside with target))	USPAT; US-PGPUB	2004/02/12 12:12
-	262448	@ad>20020316 or @rlad>20020316	USPAT; US-PGPUB	2004/02/11 17:15
-	122	(((bias with substrate) and ("DC power" with target)) and nitrogen) and (oxide or oxynitride)) not (@ad>20020316 or @rlad>20020316)	USPAT; US-PGPUB	2004/02/11 17:15
-	16	(deposit\$3 with (backside with target)) not (((bias with substrate) and ("DC power" with target)) and (deposit\$3 with (backside with target)))	USPAT; US-PGPUB	2004/02/12 12:11
-	0	(deposit\$3 with ("backside of the target")) not (((bias with substrate) and ("DC power" with target)) and (deposit\$3 with (backside with target)))	USPAT; US-PGPUB	2004/02/12 12:11
-	0	((bias with substrate) and ("DC power" with target)) and (deposit\$3 with ("backside of the target"))	USPAT; US-PGPUB	2004/02/12 12:12
-	0	deposit\$3 with ("backside of the target")	USPAT; US-PGPUB	2004/02/12 12:13
-	0	("backside of the target")	USPAT; US-PGPUB	2004/02/12 12:13



UNITED STATES PATENT AND TRADEMARK OFFICE

UNITED STATES DEPARTMENT OF COMMERCE  
United States Patent and Trademark Office  
Address: COMMISSIONER FOR PATENTS  
P.O. Box 1450  
Alexandria, Virginia 22313-1450  
www.uspto.gov

APPLICATION NO.	FILING DATE	FIRST NAMED INVENTOR	ATTORNEY DOCKET NO.	CONFIRMATION NO.
10/101,863	03/16/2002	Hongmei Zhang	M-12245 US	6938

7590 02/24/2004  
Skjerven Morrill Macpherson LLP  
Suite 700  
250 Metro Drive  
San Jose, CA 95110

EXAMINER

ESTRADA, MICHELLE

ART UNIT PAPER NUMBER

2823

DATE MAILED: 02/24/2004

Please find below and/or attached an Office communication concerning this application or proceeding.

idw

<b>Office Action Summary</b>	<b>Application No.</b> 10/101,863	<b>Applicant(s)</b> ZHANG ET AL.	
	<b>Examiner</b> Michelle Estrada	<b>Art Unit</b> 2823	

**-- The MAILING DATE of this communication appears on the cover sheet with the correspondence address --**  
**Period for Reply**

A SHORTENED STATUTORY PERIOD FOR REPLY IS SET TO EXPIRE 3 MONTH(S) FROM THE MAILING DATE OF THIS COMMUNICATION.

- Extensions of time may be available under the provisions of 37 CFR 1.136(a). In no event, however, may a reply be timely filed after SIX (6) MONTHS from the mailing date of this communication.
- If the period for reply specified above is less than thirty (30) days, a reply within the statutory minimum of thirty (30) days will be considered timely.
- If NO period for reply is specified above, the maximum statutory period will apply and will expire SIX (6) MONTHS from the mailing date of this communication.
- Failure to reply within the set or extended period for reply will, by statute, cause the application to become ABANDONED (35 U.S.C. § 133). Any reply received by the Office later than three months after the mailing date of this communication, even if timely filed, may reduce any earned patent term adjustment. See 37 CFR 1.704(b).

**Status**

- 1)  Responsive to communication(s) filed on 02 December 2003.
- 2a)  This action is **FINAL**.
- 2b)  This action is non-final.
- 3)  Since this application is in condition for allowance except for formal matters, prosecution as to the merits is closed in accordance with the practice under *Ex parte Quayle*, 1935 C.D. 11, 453 O.G. 213.

**Disposition of Claims**

- 4)  Claim(s) 1-39 is/are pending in the application.
- 4a) Of the above claim(s) 15-39 is/are withdrawn from consideration.
- 5)  Claim(s) 1-13 is/are allowed.
- 6)  Claim(s) 13 and 20 is/are rejected.
- 7)  Claim(s) 7 and 21-24 is/are objected to.
- 8)  Claim(s) \_\_\_\_\_ are subject to restriction and/or election requirement.

**Application Papers**

- 9)  The specification is objected to by the Examiner.
- 10)  The drawing(s) filed on \_\_\_\_\_ is/are: a)  accepted or b)  objected to by the Examiner.  
 Applicant may not request that any objection to the drawing(s) be held in abeyance. See 37 CFR 1.85(a).  
 Replacement drawing sheet(s) including the correction is required if the drawing(s) is objected to. See 37 CFR 1.121(d).
- 11)  The oath or declaration is objected to by the Examiner. Note the attached Office Action or form PTO-152.

**Priority under 35 U.S.C. § 119**

- 12)  Acknowledgment is made of a claim for foreign priority under 35 U.S.C. § 119(a)-(d) or (f).  
 a)  All    b)  Some \*    c)  None of:  
 1.  Certified copies of the priority documents have been received.  
 2.  Certified copies of the priority documents have been received in Application No. \_\_\_\_\_.  
 3.  Copies of the certified copies of the priority documents have been received in this National Stage application from the International Bureau (PCT Rule 17.2(a)).  
 \* See the attached detailed Office action for a list of the certified copies not received.

**Attachment(s)**

- 1)  Notice of References Cited (PTO-892)
- 2)  Notice of Draftsperson's Patent Drawing Review (PTO-948)
- 3)  Information Disclosure Statement(s) (PTO-1449 or PTO/SB/08)  
 Paper No(s)/Mail Date \_\_\_\_\_
- 4)  Interview Summary (PTO-413)  
 Paper No(s)/Mail Date \_\_\_\_\_
- 5)  Notice of Informal Patent Application (PTO-152)
- 6)  Other: \_\_\_\_\_

## **DETAILED ACTION**

### ***Election/Restrictions***

Applicant's election of Group I (claims 1-14 and 20-24) in Paper filed 12/02/03 is acknowledged. Because applicant did not distinctly and specifically point out the supposed errors in the restriction requirement, the election has been treated as an election without traverse (MPEP § 818.03(a)).

### ***Claim Rejections - 35 USC § 103***

The following is a quotation of 35 U.S.C. 103(a) which forms the basis for all obviousness rejections set forth in this Office action:

(a) A patent may not be obtained though the invention is not identically disclosed or described as set forth in section 102 of this title, if the differences between the subject matter sought to be patented and the prior art are such that the subject matter as a whole would have been obvious at the time the invention was made to a person having ordinary skill in the art to which said subject matter pertains. Patentability shall not be negated by the manner in which the invention was made.

Claims 1-13 and 20 are rejected under 35 U.S.C. 103(a) as being unpatentable over the combination of Le et al. (2003/0077914) and Fukui et al. (5,755,938).

With respect to claim 1, Le et al. disclose providing pulsed DC power (22) to a target (14) (Page 4, Paragraph [0070]); providing bias power to a substrate (16) positioned opposite the target; providing process gas between the target and the substrate (Page 4, Paragraph [0067]).

With respect to claim 7, Le et al. disclose wherein the film is an upper cladding layer of a waveguide structure and the bias power is optimized to provide planarization Page 5, Paragraph [0075].

With respect to claim 8, Le et al. disclose wherein the process gas includes a mixture of oxygen and argon (Page 4, Paragraph [0067]).

With respect to claim 9, Le et al. disclose wherein the oxygen flow is adjusted to adjust the index of refraction of the film (Page 5, Paragraph [0076]).

With respect to claim 10, Le et al. disclose wherein the process gas further includes nitrogen (Page 5, Paragraph [0074]).

With respect to claim 11, Le et al. disclose wherein providing pulsed DC power to a target includes providing pulsed DC power to a target which has an area larger than that of the substrate (See fig. 3).

With respect to claim 12, Le et al. disclose further including uniformly sweeping the target with a magnetic field (Page 5, Paragraph [0073]).

With respect to claim 13, Le et al. disclose wherein uniformly sweeping the target with a magnetic field includes sweeping a magnet in one direction across the target where the magnet extends beyond the target in the opposite direction (Page 5, Paragraph [0073]).

With respect to claim 20, Le et al. disclose conditioning a target (Page 4, Paragraph [0070]); preparing the substrate (Page 3, Paragraph [0065]); adjusting the bias power to the substrate (Page 4, Paragraph [0041]); setting the process gas flow (Page 4, Paragraph [0067]); and applying pulsed DC power to the target to deposit the film (Page 4, Paragraph [0071]).

With respect to claims 2-4 and 6, One of ordinary skill in the art would have been led to the recited temperature, DC power, time pulse and bias power to routine

experimentation to achieve a desired layer thickness, device dimension, device associated characteristics and device density on the finished wafer in view of the range of values disclosed. Furthermore, Le et al. disclose that sets of process parameters depend on the specific process chamber (Page 6, Paragraph [0081]).

In addition, the selection of temperature, DC power, time pulse and bias power, is obvious because it is a matter of determining optimum process conditions by routine experimentation with a limited number of species of result effective variables. These claims are prima facie obvious without showing that the claimed ranges achieve unexpected results relative to the prior art range. In re Woodruff, 16 USPQ2d 1935, 1937 (Fed. Cir. 1990). See also In re Huang, 40 USPQ2d 1685, 1688 (Fed. Cir. 1996)(claimed ranges or a result effective variable, which do not overlap the prior art ranges, are unpatentable unless they produce a new and unexpected result which is different in kind and not merely in degree from the results of the prior art). See also In re Boesch, 205 USPQ 215 (CCPA) (discovery of optimum value of result effective variable in known process is ordinarily within skill or art) and In re Aller, 105 USPQ 233 (CCPA 1995) (selection of optimum ranges within prior art general conditions is obvious).

Note that the specification contains no disclosure of either the critical nature of the claimed temperature, DC power, time pulse and bias power or any unexpected results arising therefrom. Where patentability is said to be based upon particular chosen temperature, DC power, time pulse and bias power or upon another variable recited in a claim, the Applicant must show that the chosen temperature, DC power,

Art Unit: 2823

time pulse and bias power are critical. *In re Woodruf*, 919 F.2d 1575, 1578, 16 USPQ2d 1934, 1936 (Fed. Cir. 1990).

Le et al. do not disclose providing a DC power through a filter.

With respect to claims 1 and 5, Fukui et al. disclose a sputtering process wherein the DC power supply (28) is connected through a band-pass filter.

It would have been within the scope of one of ordinary skill in the art to combine the teachings of Le et al. and Fukui et al. to enable the use of a DC power supply through a filter to be used in the process of Le et al. to adjust the impedance to have an infinite value so that no RF waves are superposed on a DC power from the DC power supply (Col. 6, lines 32-37).

#### ***Allowable Subject Matter***

Claims 7 and 21-24 are objected to as being dependent upon a rejected base claim, but would be allowable if rewritten in independent form including all of the limitations of the base claim and any intervening claims.

Any inquiry concerning this communication or earlier communications from the examiner should be directed to Michelle Estrada whose telephone number is 571-272-1858. The examiner can normally be reached on Monday through Friday.

If attempts to reach the examiner by telephone are unsuccessful, the examiner's supervisor, Olik Chaudhuri can be reached on 571-272-1855. The fax phone numbers

Art Unit: 2823

for the organization where this application or proceeding is assigned are 703-308-7722 for regular communications and 703-308-7724 for After Final communications.

Any inquiry of a general nature or relating to the status of this application or proceeding should be directed to the receptionist whose telephone number is 571-272-2800.



M Estrada

February 12, 2004



OLIK CHAUDHURI  
SUPERVISORY PATENT EXAMINER  
TECHNOLOGY CENTER 2800



<b>Notice of References Cited</b>	Application/Control No. 10/101,863	Applicant(s)/Patent Under Reexamination ZHANG ET AL.	
	Examiner Michelle Estrada	Art Unit 2823	Page 1 of 1

**U.S. PATENT DOCUMENTS**

*	Document Number Country Code-Number-Kind Code	Date MM-YYYY	Name	Classification
A	US-2003/0077914	04-2003	Le et al.	438/763
B	US-5,755,938	05-1998	Fukui et al.	204/298.23
C	US-5,830,330	11-1998	Lantsman, Alexander D.	204/192.12
D	US-5,607,560	03-1997	Hirabayashi et al.	204/192.15
E	US-2003/0022487	01-2003	Yoon et al.	438/642
F	US-5,942,089	08-1999	Sroul et al.	204/192.13
G	US-2003/0042131	03-2003	Johnson, Wayne L.	204/192.12
H	US-5,849,163	12-1998	Ichikawa et al.	204/192.23
I	US-2003/0141186	07-2003	Wang et al.	204/298.07
J	US-2003/0079838	05-2003	Brcka, Jozef	156/345.48
K	US-6,488,822	12-2002	Moslehi, Mehrdad M.	204/192.12
L	US-6,057,557	05-2000	Ichikawa, Takeshi	257/59
M	US-			

**FOREIGN PATENT DOCUMENTS**

*	Document Number Country Code-Number-Kind Code	Date MM-YYYY	Country	Name	Classification
N					
O					
P					
Q					
R					
S					
T					

**NON-PATENT DOCUMENTS**

*	Include as applicable: Author, Title Date, Publisher, Edition or Volume, Pertinent Pages)
U	
V	
W	
X	

\*A copy of this reference is not being furnished with this Office action. (See MPEP § 707.05(a).)  
Dates in MM-YYYY format are publication dates. Classifications may be US or foreign.

**Search Notes**



Application No.

10/101,863

Examiner

Michelle Estrada

Applicant(s)

ZHANG ET AL.

Art Unit

2823

**SEARCHED**

Class	Subclass	Date	Examiner
438	769		
438	770		
438	771		
438	787		
438	788		
427	533		
204	192.12		
204	192.15	2/12/2004	<i>ME</i>

**INTERFERENCE SEARCHED**

Class	Subclass	Date	Examiner

**SEARCH NOTES  
(INCLUDING SEARCH STRATEGY)**

	DATE	EXMR
See East search attached	2/12/2004	<i>ME</i>





PATENT  
Customer No. 22,852  
Attorney Docket No. 09140-0016-00000

IN THE UNITED STATES PATENT AND TRADEMARK OFFICE

In re Application of: )  
)  
H. Zhang, et al. ) Group Art Unit: 2823  
)  
Application No.: 10/101,863 ) Examiner: Michelle Estrada  
)  
Filed: March 16, 2002 )  
)  
For: Biased Pulsed DC Reactive Sputtering ) Confirmation No.: 6938  
of Oxide Films )

Commissioner for Patents  
P.O. Box 1450  
Alexandria, VA 22313-1450

Sir:

**REPLY TO OFFICE ACTION**

In reply to the Office Action mailed February 24, 2004, please amend the above-identified application as follows:

**Amendments to the Specification** are included starting on page 2.

**Amendments to the Claims** are reflected in the listing of claims starting on page 6.

**Remarks/Arguments** are included in this paper starting on page 9.

**AMENDMENTS TO THE SPECIFICATION:**

Please amend the specification as follows:

Please amend paragraph [0048] as indicated below:

[0048] RF sputtering of oxide films is discussed in Application Serial No. 09/903,050 (the '050 application) (now U.S. Patent No. 6,506,289) by Demaray et al., entitled "Planar Optical Devices and Methods for Their Manufacture," assigned to the same assignee as is the present invention, herein incorporated by reference in its entirety. Further, targets that can be utilized in a reactor according to the present invention are discussed in U.S. Application serial no. ~~{Attorney Docket No. M 12247 US}~~ (the '~~247 application~~') 10/101,341 (the '341 application), filed concurrently with the present disclosure, assigned to the same assignee as is the present invention, herein incorporated by reference in its entirety. A gain-flattened amplifier formed of films deposited according to the present invention are described in U.S. Application serial no. ~~{Attorney Docket No. M 12652 US}~~ (the '~~652 application~~') 10/101,493 (the '493 application), filed concurrently with the present disclosure, assigned to the same assignee as is the present invention, herein incorporated by reference in its entirety. Further, a mode size converter formed with films deposited according to the present invention is described in U.S. Application serial no. ~~{Attorney Docket No. M 12138 US}~~ (the '~~138 application~~') 10/101,492 (the '492 application), filed concurrently with the present disclosure, assigned to the same assignee as is the present invention, herein incorporated by reference in its entirety.

Please amend paragraph [0060] as indicated below:

[0060] Target 12 can be formed of any materials, but is typically metallic materials such as, for example, combinations of Al and Si. Therefore, in some embodiments, target 12 includes a metallic target material formed from ~~intermetallic~~ intermetallic compounds of optical elements such as Si, Al, Er and Yb. Additionally, target 12 can be formed, for example, from materials such as La, Yt, Ag, Au, and Eu. To form optically active films on substrate 16, target 12 can include rare-earth ions. In some embodiments of target 12 with rare earth ions, the rare earth ions can be pre-alloyed with the metallic host components to form ~~intermetallics~~ intermetallics. ~~See the '247 application.~~ See the '341 application.

Please amend paragraph [0062] as indicated below:

[0062] Several useful examples of target 12 that can be utilized in apparatus 10 according to the present invention include the following targets compositions: (Si/Al/Er/Yb) being about (57.0/41.4/0.8/0.8), (48.9/49/1.6/0.5), (92/8/0/0), (60/40/0/0), (50/50/0/0), (65/35/0/0), (70/30/0,0), and (50,48.5/1.5/0) cat. %, to list only a few. These targets can be referred to as the 0.8/0.8 target, the 1.6/.5 target, the 92-8 target, the 60-40 target, the 50-50 target, the 65-35 target, the 70-30 target, and the 1.5/0 target, respectively. The 0.8/0.8, 1.6/0.5, and 1.5/0 targets can be made by pre-alloyed targets formed from an atomization and hot-isostatic pressing (HIPing) process as described in ~~the '247 application~~ the '341 application. The remaining targets can be formed, for example, by HIPing. Targets formed from Si, Al, Er and Yb can have any composition. In some embodiments, the rare earth content can be up to 10 cat. % of the total ion content in the target. Rare earth ions are added to form active layers for amplification. Targets utilized in apparatus 10 can have any composition and can include ions other than Si, Al, Er and Yb, including: Zn, Ga, Ge, P, As, Sn, Sb, Pb, Ag, Au, and rare earths: Ce, Pr, Nd, Pm, Sm, Eu, Gd, Tb, Dy Ho, Er, Tm Yb and Lu.

Please amend paragraph [0084] as indicated below:

[0084] Figure 5 shows the voltage on target 12 of an embodiment of apparatus 10 according to the present invention as a function of process gas constitution. In the example illustrated in Figure 5, for example, a metallic target with composition .8 cat. % Er, .8 cat. % Yb, 57.4 cat. % Si and 41 cat. % Si, which can be formed as described in ~~the '247 application~~ the '341 application, was sputtered in an embodiment of apparatus 10 based on the AKT-1600 PVD system with 6 kW of pulsed DC power at a frequency of 120 kHz and a reverse time of 2.3 micro seconds. The Argon gas flow was set at 60 sccm and the Oxygen gas flow was varied from zero up to 40 sccm. For more details regarding this deposition, see Example 1 below.

Please amend paragraph [0112] as indicated below:

[0112] An AKT 1600 based reactor can be utilized to deposit a film. In this example, a wide area metallic target of dimension 550X 650 mm with composition (Si/Al/Er/Yb) being about 57.0 cat. % Si, 41.4 cat. % Al, 0.8 cat. % Er, and 0.8 cat. % Yb (a “.8/.8” target) was fabricated as described in ~~the ‘247 patent~~ the ‘341 application.

Please amend paragraph [0119] as indicated below:

[0119] A waveguide amplifier can be deposited according to the present invention. An embodiment of target 12 having composition 57.4 cat. % Si, 41.0 cat. % Al, 0.8 cat. % Er 0.8 cat. % Yb (the “.8/.8 target”) can be formed as disclosed in ~~the ‘245 application~~ the ‘341 application. The Er-Yb (0.8/0.8) co-doped Alumino-Silicate film was deposited onto a 6 inch wafer of substrate 16 which includes a 10  $\mu$ m thick thermal oxide substrate, which can be purchased from companies such as Silicon Quest International, Santa Clara, CA. Target 12 was first cleaned by sputtering with Ar (80 sccm) only in the metallic mode. Target 12 was then conditioned in poison mode by flowing 60 sccm of Argon and 40 sccm of oxygen respectively. The power supplied to target 12 during conditioning was kept at about 6 kW.

Please amend paragraph [0123] as indicated below:

[0123] This example describes production of a dual core Erbium/Yttrium co-doped amplifier according to the present invention. In one example, substrate 16 is a silicon substrate with an undercladding layer of thermally oxidized SiO<sub>2</sub> of about 15  $\mu$ m thick. Substrate 16 with the thermal oxide layer can be purchased from companies such as Silicon Quest International, Santa Clara, CA. A layer of active core material is then deposited on substrate 16 with a Shadow Mask as described in ~~the ‘138 application~~ the ‘492 application. Use of a shadow mask results in a vertical taper on each side of a finished waveguide which greatly enhances the coupling of light into and out of the waveguide.

Please amend paragraph [0128] as indicated below:

[0128] A reverse taper mode size converter, *see* ~~the ‘138 application~~ the ‘492 application, is utilized for coupling light into waveguide amplifier 300. The insertion loss at 1310 nm is about

2 dB. Figure 26 shows the amplifier performance of this example. In Figure 26, amplifier 300 is pumped with 150 mW from one side pumping with 984 nm light. Gain flattening is achieved within about 1 dB in the range 1528 nm to 1562 nm for small input signals (-20 dBm). For large input signals (0 dBm), gain flattening is also achieved within about 1 dB.

Please amend paragraph [0136] as indicated below:

[0136] This example describes the fabrication of another Er-Yb codoped waveguide amplifier according to the present invention. The active core is deposited with an embodiment of target 12 with composition about 49 cat. % Si, 48 cat. % Al, 1.6 cat. % Er and 0.5 cat. % Yb, which can be fabricated as described in ~~the '247 application~~ the '341 application. Target 12 was first cleaned by sputtering with Ar (80 sccm) only in the metallic mode. Target 12 was then conditioned in poison mode by flowing 60 sccm of Argon and 40 sccm of oxygen respectively. The pulsed DC power supplied to target 12 was kept at 5 kW. Table 4 shows photoluminescence and index of refraction of as-deposited films from this example at some typical process conditions. The units for photoluminescence are the number of counts per micron. Lifetime and photoluminescence measured after annealing at various different temperatures are shown in Table 5.



## **AMENDMENTS TO THE CLAIMS:**

This listing of claims will replace all prior versions and listings of claims in the application:

Please cancel claims 15-19 and 25-39, without prejudice.

Claim 1 (Original): A method of depositing a film on a substrate, comprising:

providing pulsed DC power through a filter to a target;

providing bias power to a substrate positioned opposite the target;

providing process gas between the target and the substrate,

wherein the filter protects a pulsed DC power supply from the bias power.

Claim 2 (Original): The method of Claim 1, further including holding the temperature of the substrate substantially constant.

Claim 3 (Original): The method of Claim 1, wherein providing pulsed DC power through the filter includes supplying up to about 10 kW of power at a frequency of between about 40 kHz and about 350 kHz and a reverse time pulse between about 1.3 and 5  $\mu$ s.

Claim 4 (Original): The method of Claim 1, wherein providing bias power to the substrate includes supplying up to 1000 W of RF power to the substrate.

Claim 5 (Original): The method of Claim 4, wherein the filter is a band reject filter at the frequency of the bias power.

Claim 6 (Original): The method of claim 4, wherein the bias power is zero.

Claim 7 (Original): The method of Claim 1, wherein the film is an upper cladding layer of a waveguide structure and the bias power is optimized to provide planarization.

Claim 8 (Original): The method of Claim 1, wherein the process gas includes a mixture of Oxygen and Argon.

Claim 9 (Original): The method of Claim 9, wherein the Oxygen flow is adjusted to adjust the index of refraction of the film.

Claim 10 (Original): The method of Claim 8, wherein the process gas further includes nitrogen.

Claim 11 (Original): The method of Claim 1, wherein providing pulsed DC power to a target includes providing pulsed DC power to a target which has an area larger than that of the substrate.

Claim 12 (Original): The method of Claim 1, further including uniformly sweeping the target with a magnetic field.

Claim 13 (Original): The method of Claim 12, wherein uniformly sweeping the target with a magnetic field includes sweeping a magnet in one direction across the target where the magnet extends beyond the target in the opposite direction.

Claim 14 (Original): The method of Claim 1, further including depositing a film on the backside of target 12.

Claims 15-19 (Canceled).

Claim 20 (Currently Amended): A method of depositing a film on a substrate, comprising:

conditioning a target;

preparing the substrate;

adjusting ~~[[the]]~~ a bias power to the substrate;

setting ~~[[the]]~~ a process gas flow; and

applying pulsed DC power to the target through a filter to deposit the film.

Claim 21 (Original): The method of Claim 20, wherein conditioning the target includes sputtering with the target in a metallic mode to remove the surface of the target and sputtering with the target in poisonous mode to prepare the surface.

Claim 22 (Original): The method of Claim 21, wherein setting the process gas flow includes adjusting constituents in order to adjust the index of refraction of the film.

Claim 23 (Original): The method of Claim 21, wherein applying pulsed DC power includes setting the frequency in order to adjust the index of refraction of the film.

Claim 24 (Original): The method of Claim 21, further including adjusting a temperature of the substrate in order to adjust the index of refraction of the film.

Claims 25-39 (Canceled).

## **REMARKS**

Claims 1-39 are pending in the above identified application. Claims 15-19 and 25-39 have been withdrawn from consideration in this application. Claims 1-14 and 20-24 are being considered in the present application. The Examiner has rejected claims 1-6, 8-13, and 20 and has objected to claims 7 and 21-24. Applicants herein traverse these rejections and request reconsideration by the Examiner. Applicants have amended the specification only to update references to pending applications that are referenced in the disclosure. Claim 20 has been amended. No new matter has been added by these amendments.

### **Election/Restrictions**

The Examiner acknowledged Applicant's election of Group I claims for consideration in the present application. On the Office Action Summary form, the Examiner has incorrectly indicated that claims 15-39 have been withdrawn from this application. Instead, claims 15-19 and 25-39 have been withdrawing while claims 1-14 and 20-24 are to be considered in the present application.

### **Claim Rejections under 35 USC § 103**

The Examiner has rejected claims 1-13 and 20 under 35 U.S.C. 103(a) as being unpatentable over the combination of Le et al. (2003/0077914) and Fukui et al. (5,755,938). However, the combination of Le and Fukui does not teach all of the elements of the claims. Further, there is no motivation to combine the references Le and Fukui as suggested by the Examiner.

As is discussed in the MPEP,

[t]o establish a prima facie case of obviousness, three basic criteria must be met. First, there must be some suggestion or motivation, either in the references themselves or in the knowledge generally available to one of ordinary skill in the art, to modify the reference or to combine reference teachings. Second, there must be a reasonable expectation of success. Finally, the prior art reference (or references when combined) must teach or suggest all the claim limitations. The teaching or suggestion to make the claimed combination and the reasonable expectation of success must both be found in the prior art, and not based on applicant's disclosure. In re Vaeck, 947 F.2d 488, 20 USPQ2d 1438 (Fed. Cir. 1991). See MPEP § 2143 - § 2143.03 for decisions pertinent to each of these criteria.

MPEP § 2142. In particular, there is no motivation to combine Le and Fukui as is suggested by the Examiner. Further, even if Le and Fukui were combined as suggested by the Examiner, the combination does not teach or suggest all of the claim elements of claims 1-13 and 20.

1. Claims 1-13 and 20 are allowable over Le and Fukui because the combination of Le and Fukui does not teach all of the elements of these claims

Claim 1 recites “providing pulsed DC power through a filter to a target” and “providing bias power to a substrate . . . .” Claim 20 recites “adjusting a bias power to the substrate” and “applying pulsed DC power to the target through a filter to deposit the film.” Le and Fukui do not teach the combination of providing pulsed DC power to the target and a bias power to the substrate or providing pulsed DC power through a filter.

Le teaches “processing of an anti-reflective coating on a substrate.” (Le, par. 0001). In particular, Le teaches a process chamber, as shown in Figure 3 of Le, where

[t]he substrate 16 is introduced into the chamber 36a through a substrate loading inlet (not shown) in a sidewall 45 of the chamber 36a and placed on the support 18. The support 18 can be lifted or lowered by support lift bellows (not shown) and a lift finger assembly (also not shown) can be used to lift and lower the

substrate 16 onto the support 18 during transport of the substrate 16 into and out of the chamber 36a.

(Le, par. 0066). Process gas is introduced to the chamber through supply 23 of Figure 3. (See, Le, pars. 0067-0069). Additionally, Le teaches that

[t]he PVD chamber 36a further comprises a sputtering target 14 comprising titanium, facing the substrate 16. A collimator (not shown) may be mounted between the target 14 and the substrate support 18 if desired. The PVD chamber 36a may also have a shield 20 to protect a wall 12 of the chamber 36a from sputtered material, and typically, to also serve as an anode grounding plane. The shield 20 is electrically floating or grounded. The target 14 is electrically isolated from the chamber 36a and is connected to a voltage source, such as a pulsed DC power source 22, but which may also be other types of voltage sources. In one version, the pulsed DC power source 22, target 14, and shield 20 operate as a gas energizer 90 that is capable of energizing the sputtering gas to sputter material from the plasma. The pulsed DC power source 22 applies a pulsed DC voltage to the target 14 relative to the shield 20. The electric field generated in the chamber 36a from the voltage applied to the sputtering target 14 energizes the sputtering gas to form a plasma that sputters off the target material.

(Le, par. 0070).

Therefore, as described in Le, a pulsed DC power supply is connected to the target.

However, no bias is applied to the substrate as is suggested by the Examiner. (See, OA, pgs. 2).

At best, Le teaches that “shield 20 is electrically floating or grounded,” (Le, par. 0070), which is not a bias as claimed in claims 1 and 20 of the present application.

Furthermore, as opposed to the Examiner’s suggestion, the teaching of Fukui et al. does not cure the defects in the teachings of Le. In particular, Fukui teaches “[a]n apparatus which allows a first film to be formed on a substrate by chemical vapor deposition (CVD) and a second film to be formed on the substrate by sputtering . . . .” (Fukui, abstract). In particular, Fukui teaches a process chamber as shown in Figure 1 of Fukui. As described by Fukui,

[i]n the deposition chamber 10, as shown in FIG. 1, a first electrode 20 is disposed in a top portion thereof and a target 21 is detachably attached to a lower surface of the first electrode 20, while a second electrode 22 is disposed in a bottom portion of the deposition chamber 10 and a substrate 23 is detachably attached to an upper surface of the second electrode 22. The target 21 can be attached in place by using a known target mounting mechanism such as an electrostatic chuck.

(Fukui, col. 6, lines 10-18). Further, Fukui teaches that

[a]n RF power supply (first power supply) 25 for outputting RF power is connected to the first electrode 20 with a matching circuit 26 inserted between the first electrode 20 and the RF power supply 25. The matching circuit 26 serves to make zero reflected waves of the RF power.

(Fukui, col. 6, lines 26-30). Therefore, Fukui teaches that RF power is coupled to the target through a matching circuit. In addition, Fukui teaches that a DC power supply is coupled to bias the target. As Fukui states,

[a]lso connected to the first electrode 20 is a dc power supply 28 through a band-pass filter 27 such as a low-pass filter for adjustment of impedance. The band-pass filter 27 serves to adjust the circuit impedance to have an infinite value so that no RF waves are superposed on a dc power from the dc power supply 28.

(Fukui, col. 6, lines 26-36). Therefore, Fukui teaches utilizing a DC power supply coupled through a filter to the target. Additionally, Fukui teaches applying another RF power supply to the second electrode. As is stated in Fukui,

[f]urther, an RF power supply (second power supply) 30 for outputting RF power is connected to the second electrode 22 with a matching circuit 31 inserted between the second electrode 22 and the RF power supply 30, the matching circuit 31 serving to act as with the matching circuit 26.

(Fukui, col. 6, lines 37-41).

Therefore, Fukui teaches applying RF power supplies to both target and substrate and applying a DC voltage to the target. Fukui does not teach a pulsed DC power supply or applying

power from a pulsed DC power supply through a filter to the target, as is suggested by the Examiner. (OA, page 5).

Therefore, the combination of Le and Fukui do not teach “providing pulsed DC power through a filter to a target” as is recited in claim 1 or “applying pulsed DC power to the target through a filter to deposit the film” as is recited in claim 20. Additionally, the combination of Le and Fukui does not suggest the combination of providing pulsed DC power to the target and a bias power to the substrate or providing pulsed DC power through a filter. Therefore, claims 1 and 20 are allowable over the combination of Le and Fukui because that combination does not teach all of the elements of the claims.

Claims 2-13 depend from claim 1 and are therefore allowable for at least the same reasons as is claim 1. The Examiner’s comments with regard to claims 2-13 are rendered mute by this discussion and therefore Applicant’s neither comments on nor agrees with those comments.

2. Claims 1-13 and 20 are allowable over Le and Fukui because there is no motivation to combine Le and Fukui as is suggested by the Examiner

The Examiner has not fulfilled the burden required to show obviousness of claims 1-13 and 20 over Le and Fukui. Instead, the Examiner has utilized impermissible hindsight to combine these two references. As discussed in the MPEP,

[t]he initial burden is on the examiner to provide some suggestion of the desirability of doing what the inventor has done. "To support the conclusion that the claimed invention is directed to obvious subject matter, either the references must expressly or impliedly suggest the claimed invention or the examiner must present a convincing line of reasoning as to why the artisan would have found the claimed invention to have been obvious in light of the



teachings of the references." Ex parte Clapp, 227 USPQ 972, 973 (Bd. Pat. App. & Inter. 1985). See MPEP § 2144 - § 2144.09 for examples of reasoning supporting obviousness rejections.

MPEP § 2142. The Examiner simply states that “[i]t would have been within the scope of one of ordinary skill in the art to combine the teachings of Le et al. and Fukui et al. to enable the use of a DC power supply through a filter to be used in the process of Le et al. to adjust the impedance to have an infinite value so that no RF waves are superposed on a DC power form [sic] the DC power supply (Col. 6, lines 32-37).” (OA, page 5). However, Le utilizes a pulsed DC power supply and not a DC power supply. Therefore, utilizing a filter provided for a DC power supply is not obvious and may not be necessary in the system taught by Le because of the lack of a bias.

Fukui teaches an RF power supply coupled to the target but does not teach a pulsed DC power supply. Instead, Fukui utilizes a dual RF system where an RF power supply is coupled to the target and another RF power supply is coupled to the substrate. There is no suggestion in Fukui that a pulsed DC power supply can be substituted for the RF power supply coupled to the target, nor would one skilled in the art be inclined to replace that RF power supply with a pulsed DC power supply. Further, there is no suggestion in Le to substitute a pulsed DC supply for an RF power supply.

Additionally, Fukui claims several advantages to utilizing separate RF power supplies on the two electrodes (i.e., coupled to the target and the substrate) during depositions, in effect teaching away from application of other power supplies. In particular, Fukui suggests that “[s]ince the first and second electrodes are provided in the deposition chamber and are supplied with the RF power separately, the ion bombardment energy and the ion flux can be controlled independently of each other.” (Fukui, col. 9, lines 23-26). As a result, several benefits of the Fukui process are discussed in Fukui, including controlled cleaning of the deposition chamber,

*See* Fukui, col. 9, lines 26-29, film depositions can be performed in optimum conditions, *See* Fukui, col. 9, lines 35-36, and along with a small DC bias placed on the target, greater sputtering efficiency can be achieved, *See* Fukui, col. 9, lines 46-48.

As discussed above, therefore, there is no motivation for one skilled in the art to combine the references Le and Fukui in the fashion suggested by the Examiner. Therefore, claims 1 and 20 are not obvious from the references Le and Fukui. Claims 2-13 depend from claim 1 and are therefore allowable for at least the same reasons as is claim 1. The Examiner's comments with regard to claims 2-13 are rendered mute by this discussion and therefore Applicant's neither comments on nor agrees with those comments.

#### **Allowable Subject Matter**

The Examiner has objected to claims 7 and 21-24 "as being dependent upon a rejected base claim, but would be allowable if rewritten in independent form including all of the limitations of the base claim and any intervening claims." (OA, page 5). As discussed above, claim 1 is allowable over the cited art. Claim 7 depends from claim 1 and is therefore allowable for at least the same reasons as is claim 1. Applicants, therefore, decline to amend claim 7 to include the limitations of claim 1.

Similarly, claims 21-24 depend on the allowable claim 20 and are therefore allowable for at least the same reasons as is claim 20. Applicants, therefore, decline to amend claims 21-24 to include the limitations of claim 20 and any intervening claims.

**Conclusion**

In view of the foregoing amendments and remarks, Applicant respectfully requests reconsideration and reexamination of this application and the timely allowance of the pending claims.

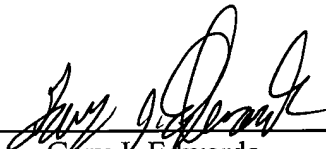
Please grant any extensions of time required to enter this response and charge any additional required fees to our deposit account 06-0916.

Respectfully submitted,

FINNEGAN, HENDERSON, FARABOW,  
GARRETT & DUNNER, L.L.P.

Dated: July 23, 2004

By: \_\_\_\_\_



Gary J. Edwards  
Reg. No. 41,008



*filed* 2823  
 PATENT  
 Customer No. 22,852  
 Attorney Docket No. 09140-0016-00000

IN THE UNITED STATES PATENT AND TRADEMARK OFFICE

In re Application of: )  
 )  
 H. Zhang, et al. ) Group Art Unit: 2823  
 )  
 Application No.: 10/101,863 ) Examiner: Michelle Estrada  
 )  
 Filed: March 16, 2002 ) Confirmation No.: 6938  
 )  
 For: BIASED PULSED DC REACTIVE )  
 SPUTTERING OF OXIDE FILMS )

Commissioner for Patents  
 P.O. Box 1450  
 Alexandria, VA 22313-1450

Sir:

**TRANSMITTAL LETTER**

Enclosed is a reply to the Office Action of February 24, 2004. The item(s) checked below are appropriate:

- Applicant(s) hereby petition(s) for a 2 month(s) extension of time to respond to the above Office Action. The Commissioner is hereby authorized to charge the fee of \$210 for the Extension to our deposit account No. 06-0916.

The claims are calculated below:

	Claims Remaining After Amendment		Highest Number Previously Paid	Present Extra	Rate	Additional Fee
Total	24	-	39	0	x \$ 18	\$ 0
Indep.	2	-	5	0	x \$ 86	\$ 0
<input type="checkbox"/> First Presentation of Multiple Dep. Claim(s)					+\$290	
Subtotal						\$
Reduction by 1/2 if small entity						-
TOTAL						\$ 0

- A fee of \$0 to cover the cost of the additional claims added by this reply is enclosed.

Commissioner is hereby authorized to charge a fee of \$180 to our deposit account No. 06-0916 to cover filing of Information Disclosure Statement under 37 C.F.R. §1.97(c).

A check for \$0 to cover the above fee(s) is enclosed.

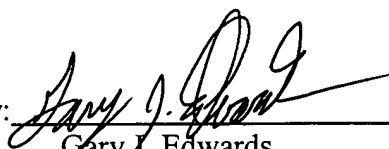
Please grant any extensions of time required to enter this response and charge any additional required fees to our deposit account 06-0916.

Respectfully submitted,

FINNEGAN, HENDERSON, FARABOW,  
GARRETT & DUNNER, L.L.P.

Dated: July 23, 2004

By: \_\_\_\_\_



Gary J. Edwards

Reg. No. 41,008



PATENT  
Customer No. 22,852  
Attorney Docket No. 09140-0016-00000

IN THE UNITED STATES PATENT AND TRADEMARK OFFICE

In re Application of: )  
)  
H. Zhang, et al. ) Group Art Unit: 2823  
)  
Application No.: 10/101,863 ) Examiner: Michelle Estrada  
)  
Filed: March 16, 2002 ) Confirmation No.: 6938  
)  
For: Biased Pulsed DC Reactive Sputtering )  
of Oxide Films )

Commissioner for Patents  
P.O. Box 1450  
Alexandria, VA 22313-1450

Sir:

**PETITION FOR 2 MONTH EXTENSION OF TIME**

Applicants hereby petition for a two month extension of time to reply to the Office Action of February 24, 2004. Commissioner is hereby authorized to charge a fee of \$210.00 to our deposit account No. 06-0916.

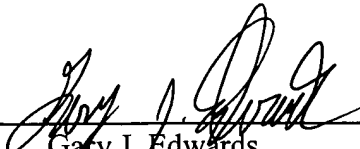
Please grant any extensions of time required to enter this response and charge any additional required fees to our deposit account 06-0916.

Respectfully submitted,

FINNEGAN, HENDERSON, FARABOW,  
GARRETT & DUNNER, L.L.P.

07/26/2004 HDEMESS1 00000013 060916 10101863  
02 FC:2252 210.00 DA

Dated: July 23, 2004

By:   
Gary J. Edwards  
Reg. No. 41,008



PATENT  
Customer No. 22,852  
Attorney Docket No. 09140-0016-00000

IN THE UNITED STATES PATENT AND TRADEMARK OFFICE

In re Application of: )  
)  
H. Zhang, et al. ) Group Art Unit: 2823  
)  
Application No.: 10/101,863 ) Examiner: Michelle Estrada  
)  
Filed: March 16, 2002 ) Confirmation No.: 6938  
)  
For: Biased Pulsed DC Reactive Sputtering )  
of Oxide Films )

Commissioner for Patents  
P.O. Box 1450  
Alexandria, VA 22313-1450

Sir:

**INFORMATION DISCLOSURE STATEMENT UNDER 37 C.F.R. § 1.97(c)**

Pursuant to 37 C.F.R. §§ 1.56 and 1.97(c), Applicants brings to the attention of the Examiner the documents listed on the attached PTO 1449. This Information Disclosure Statement is being filed after the events recited in Section 1.97(b) but, to the undersigned's knowledge, before the mailing date of either a Final action, Quayle action, or a Notice of Allowance. Under the provisions of 37 C.F.R. § 1.97(c), the Commissioner is hereby authorized to charge a fee of \$180.00 as specified by Section 1.17(p) to our deposit account No. 06-0916.

Copies of the listed documents are attached.

Applicants respectfully request that the Examiner consider the listed documents and indicate that they were considered by making appropriate notations on the attached form.

This submission does not represent that a search has been made or that no better art exists and does not constitute an admission that each or all of the listed documents are

material or constitute "prior art." If the Examiner applies any of the documents as prior art against any claims in the application and Applicants determine that the cited documents do not constitute "prior art" under United States law, Applicants reserve the right to present to the office the relevant facts and law regarding the appropriate status of such documents.

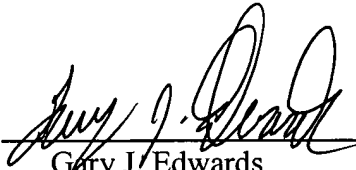
Applicants further reserve the right to take appropriate action to establish the patentability of the disclosed invention over the listed documents, should one or more of the documents be applied against the claims of the present application.

If there is any additional fee due in connection with the filing of this Statement, please charge the fee to our Deposit Account No. 06-0916.

Respectfully submitted,

FINNEGAN, HENDERSON, FARABOW,  
GARRETT & DUNNER, L.L.P.

Dated: July 23, 2004

By:   
\_\_\_\_\_  
Gary J. Edwards  
Reg. No. 41,008





**INFORMATION DISCLOSURE CITATION**

Atty. Docket No.	09140-0016	Appln. No.	10/101,863
Applicant	ZHANG et al.		
Filing Date	March 16, 2002	Group:	2823

U.S. PATENT DOCUMENTS						
Examiner Initial*	Document Number	Issue Date	Name	Class	Sub Class	Filing Date If Appropriate
	2002/0106297		Ueno et al.	419	12	Aug. 08, 2002
	2003/0019326		Han et al.	45	245	Jan. 30, 2003
	2003/0063883		Demaray et al.	385	129	Apr. 3, 2003
	2003/0175142		Milonopoulou et al.	419	49	Sep. 18, 2003
	4,437,966	Mar. 7, 1961	Hope et al	204	298	
	4,915,810	Apr. 10, 1990	Kestigian et al.	204	298.04	
	4,978,437	Dec. 18, 1990	Wirz	204	192.	
	5,174,876	Dec. 29, 1992	Buchal et al.	427	526	
	5,200,029	Apr. 6, 1993	Bruce et al.	156	657	
	5,206,925	Apr. 27, 1993	Nakazawa et al.	385	142	
	5,225,288	Jul. 6, 1993	Beeson et al.	428	475.5	
	5,237,439	Aug. 17, 1993	Misono et al.	359	74	
	5,252,194	Oct. 12, 1993	Demaray et al.	204	298	
	5,303,319	Apr. 12, 1994	Ford et al.	385	131	
	5,381,262	Jan. 10, 1995	Arima et al.	359	341	
	5,427,669	Jun. 27, 1995	Drummond	204	298.2	
	5,475,528	Dec. 12, 1995	LaBorde	359	341	
	5,483,613	Jan. 9, 1996	Bruce et al.	385	129	
	5,555,127	Sep. 10, 1996	Abdelkader et al.	359	341	
	5,565,071	Oct. 15, 1996	Demaray et al.	204	192	
	5,603,816	Feb. 18, 1997	Demaray et al.	204	298	

Examiner	Date Considered
<p>*Examiner: Initial if reference considered, whether or not citation is in conformance with MPEP 609; draw line through citation if not in conformance and not considered. Include copy of this form with next communication to applicant.</p>	
Form PTO 1449	Patent and Trademark Office - U.S. Department of Commerce



INFORMATION DISCLOSURE CITATION

Priority Docket No.	09140-0016	Appln. No.	10/101,863
Applicant	ZHANG et al.		
Filing Date	March 16, 2002	Group:	2823

U.S. PATENT DOCUMENTS						
Examiner Initial*	Document Number	Issue Date	Name	Class	Sub Class	Filing Date If Appropriate
	5,613,995	Mar. 25, 1997	Bhandarkar et al.	65	384	
	5,654,054	Aug. 5, 1997	Tropsha et al.	428	36.6	
	5,693,956	Dec. 2, 1997	Shi et al.	257	40	
	5,718,813	Feb. 17, 1998	Drummond	204	192.2	
	5,719,976	Feb. 17, 1998	Henry et al.	385	50	
	5,792,550	Aug. 11, 1998	Phillips et al.	428	336	
	5,841,931	Nov. 24, 1998	Foresi et al.	385	131	
	5,847,865	Dec. 8, 1998	Gopinath et al.	359	343	
	5,855,744	Jan. 5, 1999	Halsey et al.	204	192	
	5,948,215	Sep. 7, 1999	Lantsman	204	192.12	
	5,961,682	Oct. 5, 1999	Lee et al.	65	384	
	5,977,582	Nov. 2, 1999	Fleming et al.	257	310	
	6,001,224	Dec. 14, 1999	Drummond	204	192.12	
	6,024,844	Feb. 15, 2000	Drummond et al.	204	192.12	
	6,051,114	Apr. 18, 2000	Yao et al.	204	192.3	
	6,093,944	Jul. 25, 2000	VanDover	257	310	
	6,162,709	Dec. 19, 2000	Raux et al.	438	513	
	6,176,986	Jan. 23, 2001	Watanabe et al.	204	298.13	
	6,248,291	Jun. 19, 2001	Nakagama et al.	419	46	
	6,280,585 B1	Aug. 28, 2001	Obinata et al.	204	298.19	
	6,287,986	Sep. 11, 2001	Mihara	438	763	

Examiner	Date Considered
<p>*Examiner: Initial if reference considered, whether or not citation is in conformance with MPEP 609; draw line through citation if not in conformance and not considered. Include copy of this form with next communication to applicant.</p>	
Form PTO 1449	Patent and Trademark Office - U.S. Department of Commerce



**INFORMATION DISCLOSURE CITATION**

Atty. Docket No.	09140-0016	Appln. No.	10/101,863
Applicant	ZHANG et al.		
Filing Date	March 16, 2002	Group:	2823

U.S. PATENT DOCUMENTS						
Examiner Initial*	Document Number	Issue Date	Name	Class	Sub Class	Filing Date If Appropriate
	6,290,822	Sep. 18, 2001	Fleming et al.	204	192.22	
	6,344,419	Feb. 5, 2002	Forster et al.	438	758	
	6,350,353	Feb. 26, 2002	Gopalraja et al.	204	192.3	
	6,358,810	Mar. 19, 2002	Dornfest et al.	438	396	
	6,409,965	Jun. 25, 2002	Nagate et al.	419	26	
	6,413,382	Jul. 2, 2002	Wang et al.	204	192.12	
	6,537,428	Mar. 25, 2003	Xiong et al.	204	192.13	
	6,602,338	Aug. 5, 2003	Chen et al.	252	301.4	

FOREIGN PATENT DOCUMENTS						
Document Number	Publication Date	Country	Class	Sub Class	Translation Yes or No	
EP 0 820 088	01/21/98	Europe	H 01 J	37/34		
EP 0 867 985 A1	09/01/98	Europe	H 01 S	3/06		
JP 6-010127	01/18/94	Japan	C 23 C	14/35	Abstract	
JP 6-100333	12/04/94	Japan	C 03 C	21/00	Abstract	
WO 00/22742	04/01/00	PCT	H 04 B			
WO 00/36665	06/22/00	PCT	H 01 L	51/20		
WO 02/12932	02/14/02	PCT	H 01 S	3/16		
WO 96/23085	08/01/96	PCT	C 23 C	14/34		
WO 97/35044	09/25/97	PCT	C 23 C	14/40		

Examiner	Date Considered
*Examiner: Initial if reference considered, whether or not citation is in conformance with MPEP 609; draw line through citation if not in conformance and not considered. Include copy of this form with next communication to applicant.	
Form PTO 1449	Patent and Trademark Office - U.S. Department of Commerce



INFORMATION DISCLOSURE CITATION

Pat. Docket No.	09140-0016	Appln. No.	10/101,863
Applicant	ZHANG et al.		
Filing Date	March 16, 2002	Group:	2823

OTHER DOCUMENTS (Including Author, Title, Date, Pertinent Pages, Etc.)	
	BARBIER, Denis, "Performances and potential applications of erbium doped planar waveguide amplifiers and lasers," <i>GeeO</i> , pp. 58-63.
	BELKIND et al., "Using pulsed direct current power for reactive sputtering of Al <sub>2</sub> O <sub>3</sub> ," <i>J. Vac. Sci. Technol. A</i> 17(4), pp. 1934-40 (Jul. 1999).
	BYER et al., "Nonlinear Optics and Solid-state Lasers," <i>IEEE Journal on Selected Topics in Quantum Electronics</i> , Vol. 6, No. 6, pp. 921-929 (Nov. 2000).
	FUJII et al, "1.54 mm photoluminescence of Er <sup>3+</sup> doped into SiO <sub>2</sub> films containing Si nanocrystals: Evidence for energy transfer from Si nanocrystals for Er <sup>3+</sup> ," <i>Appl. Phys. Lett.</i> , 71 (9), pp. 1198-1200 (September, 1997).
	KELLY et al., "Reactive pulsed magnetron sputtering process for alumina films," <i>J. Vac. Sci. Technol. A</i> 18(6), pp. 2890-96 (Nov. 2000).
	KELLY et al., "Control of the structure and properties of aluminum oxide coatings deposited by pulsed magnetron sputtering," <i>J. Vac. Sci. Technol. A</i> 17(3), pp. 945-953 (May 1999).
	PAN et al., "Planar Er <sup>3+</sup> -doped aluminosilicate waveguide amplifier with more than 10 dB gain across C-band," <i>Optical Society of America</i> , 3 pages (2000).
	ROBERTS et al., "The Photoluminescence of Erbium-doped Silicon Monoxide," <i>Department of Electronics and Computer Science</i> , 7 pages (June 1996).
	SCHILLER et al. "PVD Coating of Plastic Webs and Sheets with High Rates on Large Areas," <i>European Materials Research Society 1999 Spring Meeting, Strasbourg, France</i> (June 1-4, 1999).
	SHAW et al. "Use of Vapor Deposited Acrlate Coatings to Improve the Barrier Properties of MetallizedFilm," <i>Society of Vacuum Coaters 505/856-7168, 37th Annual Technical Conference Proceedings</i> , pp. 240-244 (1994).
	SHIN et al. "Dielectric and Electrical Properties of Sputter Grown (Ba,Sr)TiO <sub>3</sub> Thin Films," <i>J. Appl. Phys.</i> , Vol. 86, No. 1, pp. 506-513, (July 1, 1999).
	SHMULOVICH et al., "Recent progress in Erbium-doped waveguide amplifiers," <i>Bell Laboratories</i> , 3 pages (1999).
	TING et al., "Study of planarized sputter-deposited SiO <sub>2</sub> ," <i>J. Vac. Sci. Technol.</i> , 15(3) pp. 1105-1112 (May/Jun. 1978).

Examiner	Date Considered
*Examiner: Initial if reference considered, whether or not citation is in conformance with MPEP 609; draw line through citation if not in conformance and not considered. Include copy of this form with next communication to applicant.	
Form PTO 1449	Patent and Trademark Office - U.S. Department of Commerce



This Page Is Inserted by IFW Operations  
and is not a part of the Official Record

## **BEST AVAILABLE IMAGES**

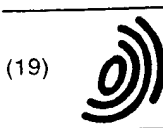
Defective images within this document are accurate representations of the original documents submitted by the applicant.

Defects in the images may include (but are not limited to):

- BLACK BORDERS
- TEXT CUT OFF AT TOP, BOTTOM OR SIDES
- FADED TEXT
- ILLEGIBLE TEXT
- SKEWED/SLANTED IMAGES
- COLORED PHOTOS
- BLACK OR VERY BLACK AND WHITE DARK PHOTOS
- GRAY SCALE DOCUMENTS

**IMAGES ARE BEST AVAILABLE COPY.**

**As rescanning documents *will not* correct images,  
please do not report the images to the  
Image Problem Mailbox.**



Europäisches Patentamt  
 European Patent Office  
 Office européen des brevets



(11) EP 0 820 088 A2

(12)

**EUROPEAN PATENT APPLICATION**

(43) Date of publication:  
 21.01.1998 Bulletin 1998/04

(51) Int Cl.<sup>6</sup>: H01J 37/34

(21) Application number: 97305316.8

(22) Date of filing: 16.07.1997

(84) Designated Contracting States:  
 AT BE CH DE DK ES FI FR GB GR IE IT LI LU MC  
 NL PT SE

- Black, Russell  
 Longmont, Colorado 80501 (US)
- Hosokawa, Akihiro  
 Cupertino, California 95014 (US)
- de Salvo, Allan M.  
 Los Gatos, California 95030 (US)
- Hall, Victoria L.  
 Menlo Park, California 94025 (US)

(30) Priority: 19.07.1996 US 684446

(71) Applicant: APPLIED KOMATSU TECHNOLOGY,  
 INC.  
 Shinjuku, Tokyo (JP)

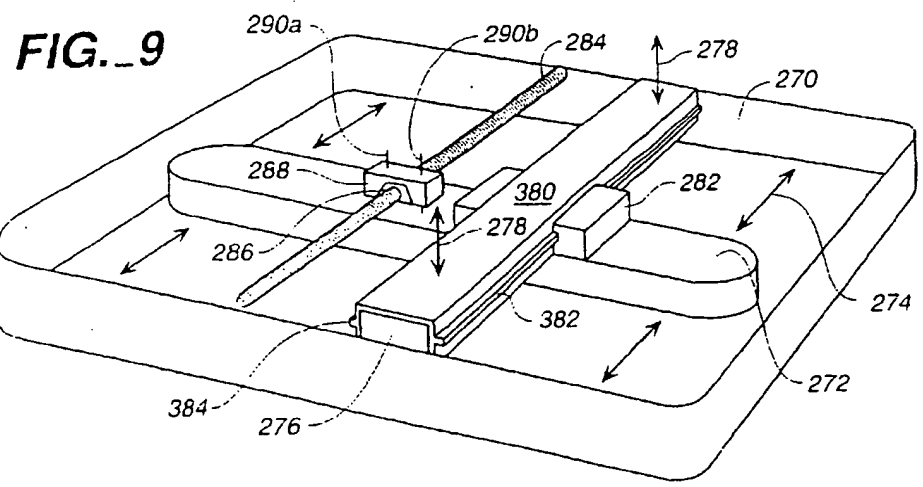
(74) Representative: Bayliss, Geoffrey Cyril et al  
 BOULT WADE TENNANT,  
 27 Furnival Street  
 London EC4A 1PQ (GB)

- (72) Inventors:
- Halsey, Harlan L.  
 Woodside, California 94062 (US)
  - Demaray, Richard E.  
 Portola Valley, California 94028 (US)

(54) **Non-planar magnet tracking device for magnetron sputtering apparatus**

(57) The structure and method which improves the film thickness uniformity or thickness control when using magnetron sputtering by adjusting the distance between the magnetron (272) or a portion of the magnetron and the sputtering target to provide an improvement in the film thickness uniformity. Shimmed rails (382; 384) con-

toured rails, contoured surfaces (415, 418), cam plates (422), and cam plate control followers (442) are utilized to achieve an improvement in film thickness uniformity or thickness control due to anomalies in magnetic field as a magnetron assembly (272) moves back and forth when sputtering substrates (utilized primarily for rectangularly shaped substrates).



EP 0 820 088 A2

## Description

This invention relates to the field of magnetrons and particular configurations for their use with sputtering chambers to control film thickness for sputter deposited film. In particular this invention relates to controlling the deposited film thickness on substrates by varying the distance between a portion of the permanent magnets comprising the magnet array in the magnetron and the sputtering target as the magnetron moves laterally across the back of the sputtering target during sputtering.

Sputtering describes a number of physical techniques commonly used in, for example, the semiconductor industry for the deposition of thin films of various metals such as aluminum, aluminum alloys, refractory metal silicides, gold, copper, titanium, titanium-tungsten, tungsten, molybdenum, tantalum and less commonly silicon dioxide and silicon on an item (a substrate), for example a substrate or glass plate being processed. In general, the techniques involve producing a gas plasma of ionized inert gas "particles" (atoms or molecules) by using an electrical field in an evacuated chamber. The ionized particles are then directed toward a "target" and collide with it. As a result of the collisions, free atoms or neutral or ionized groups of atoms of the target material are released from the surface of the target, essentially liberating target material are released from the surface of the target, essentially liberating atomic-level particles from the target material. Many of the free particles which escape the target surface condense and form (deposit) a thin film on the surface of the object (e.g. wafer, substrate) being processed, which is located a relatively short distance from the target.

One common sputtering technique is magnetron sputtering. When processing substrates using magnetron sputtering, sputtering action is concentrated in the region of the magnetic field on the target surface so that sputtering occurs at a higher rate and at a lower process pressure than possible without the use of magnets. The target itself is electrically biased with respect to the substrate and chamber, and functions as a cathode. Objectives in engineering the cathode and its associated magnetic field source include uniform erosion of the target and uniform deposition of pure target material on the substrate being processed.

If, during sputtering, magnets generating a magnetic field are stationary at a location, then continuous sputtering consumes a disproportionate fraction of the sputtering target thickness at that location quickly and generates hot spots at the locations of sputtering. Therefore magnets are continuously moved across the back side of the target in a path designed to cause uniform utilization of the target's surface and sputter deposit a correspondingly uniform film thickness on the substrate being processed. Sputtering a target creates a deposition pattern on the substrate which generally matches the utili-

zation (erosion) pattern on the target surface.

To avoid contamination of the processing chamber and substrate processed therein, sputtering is stopped before the non-uniform sputtering wear pattern has consumed the full thickness of the target material at any point. If any point on the plate behind the target were to be reached, sputtering of the target backing plate material (often copper) would occur, contaminating the vacuum chamber and the substrate being processed with the target backing material. Because of the non-uniform pattern of target utilization, sputtering is usually stopped when a large percentage of the target remains.

As the target erodes, the distance between the target surface (which is eroding away) and the substrate being sputtered is slowly increasing. The change in the distance between the target surface and the substrate being sputtered creates a change in the qualities of the sputtered material deposited and its uniformity. When material is deposited on large areas such as glass plates, variations in the thickness of deposited sputtered material are measurable and, may be unacceptable.

In generating the gas plasma and creating ion streams impacting on the cathode, considerable energy is supplied. This energy must be dissipated to avoid melting or nearly melting the structures and components involved. A common technique used for cooling sputtering targets is to pass water or other cooling liquid through a fixed internal passage of the sputtering target. Another cooling technique which is commonly used is to expose a back side of a target to a cooling bath. Cooling liquid circulating through the bath container assists in controlling the temperature of the back of the target assembly. A magnet assembly (magnetron) located on the back side of the target with a backside cooling bath moves within the liquid of the cooling bath.

Figures 1, 2, and 3 show a prior art sputtering chamber 50 in which a rectangular substrate 64 (shown in dashed lines in Fig. 1) is supported on a pedestal 52. A target assembly 58, consisting of a target backing plate 56 and a target 54 having a front face facing the pedestal 52, covers the upper flange of the processing chamber sealing it. On the side of the target assembly opposite from the pedestal 52 a magnetron chamber 60 encloses a magnetron assembly 62. The magnetron chamber 60 can be made vacuum tight to reduce the differential pressure across the target assembly 58 (with cooling fluid being routed through the target assembly), or it can be filled with cooling liquid to provide a cooling bath in contact with the back side of the target assembly 58. To enhance sputtering of a rectangular shaped substrate 64 (generally matching the shape of the outside of the chamber 50) the magnetron assembly 62 is a linear bar with rounded ends. The magnetron assembly 62 moves in a horizontal, back and forth (reciprocal) pattern within the magnetron chamber 62 as shown in by the arrows 68. The magnetron assembly passes through the magnetron chamber 62 and to the dashed outline of the magnetron assembly 62a. The outline of the area covered



by magnetron movement is shown by the dashed line 66.

The magnetron assembly 62 as shown in Figure 3 runs parallel to the target assembly 58 along one of a range of elevations between the low and high extremes (e.g., 96, 98), which are greatly exaggerated in this figure. The particular elevation (e.g., 96, 98) is dependent on the desired distance 92 from the front face of the target 54, which in turn determines the degree of sputtering enhancement desired for a particular process chamber pressure and sputtering process being used.

A conceptualized illustration of the magnetic field present around the strong Neodymium Boron Iron magnets used in the magnetron assembly is shown in the cross section of Figure 4. The positive poles 72, 74, 76, 78 of the magnets shown, e.g., 70, are on the top (away from the sputtering target) in the outside loop 84 (Fig. 1) of permanent magnets and on the bottom (close to the sputtering target) in the inside loop 82 (Fig. 1), although the polarities may be reversed. A magnet backing plate 80 bridges the magnetic field on the top side of the magnetron thus preventing the magnetic field from extending up from the top side of magnetron assembly. In contrast, the magnetic field on the bottom side between adjacent magnets is conceptualized by the loops 86 showing a diminishing magnetic field strength farther down from the magnetron assembly 62. The loops of the magnetic field lines 86, portray a comparatively strong magnetic field in the loop 88 adjacent to the magnets, and drop off in the magnetic field strength rapidly as a function of the distance to a comparatively weakened magnetic field strength at the loop 90 farthest from the magnets. (The loops show an approximation of the diminution of the magnet field strength with distance). Any vertical movement of the magnetron assembly 62 that increases the distance between the front face of the target and the magnetron assembly 62 from the distance 92 (Fig. 3) to the distance 94 (Fig. 5), reduces the magnetic field strength at the surface of the target facing the pedestal 52 by a factor of approximately 5, relative to the range of field strength loops shown in Figure 4.

Figure 6 shows a target erosion profile for a target of 6061 Al in 2000 kilowatt hour power range. The contours shown by the plot show a generally uniform utilization of the target with a slight increase in erosion near the ends of the profile (a dwell location). The pattern observable from at the dwell locations corresponds to the shape of the magnet field emanating from magnetron assembly. The target erosion profile as shown here is related to the rate of deposition and film thickness uniformity or thickness control on a substrate being sputtered located opposite such a target (areas showing greater erosion on the target result in areas having greater deposition on the substrate). In this particular instance, there are two areas of relatively high erosion, one at the upper right corner 242 and the other at lower left hand corner 244 of Figure 6, which produce corre-

sponding deposition thickness anomalies on the substrate being sputtered.

The current specifications for target film thickness uniformity (even for large plates, such as the 50 by 60 centimeter plate shown in Figure 6) is 5% or better. The anomalies of high erosion at the corners of the target as shown by the regions 242, 244 cause great concern in meeting the specification as they distort the film thickness uniformity so that a film thickness uniformity of only approximately 7% can be achieved. To improve uniformity the excessive erosion in the two regions 242, 244 must be reduced or eliminated so that the specification for film thickness uniformity can be met.

The observation of the high erosion in the corners has initiated a great deal of scrutiny without an identification of its true source. The positioning of an array of permanent magnets in the magnetron assembly assures a uniform magnetic field throughout the magnetron assembly. The general uniformity of the magnet field emanating from the magnetron is confirmed by the generally uniform erosion profile across the center of face of the target. Speculation about the source of the reason for the anomaly in the corners included research to determine whether a source of electrical or magnetic field anomalies could be identified. None has been identified.

Figure 7 is a plot representing the film thickness on the surface of a substrate. It confirms the uniformity of the film thickness on the surface of a rectangular substrate. This plot shows an approximately mirror image correlation with the target erosion profile of Figure 6.

In the field of thin film deposition, a size of substrates is becoming larger and larger since there is increasing need for larger size LCD screen. For example, current substrate size for production is up to 400 mm X 500 mm, however, the size will be expanded up to 600 mm X 700 mm or larger in the future.

One of the most difficult tasks in thin film deposition is how to achieve uniform deposition over a substrate. This shortcoming becomes the dominant factor preventing the economical production of larger and larger LCD screens.

The shortcomings in film thickness uniformity or thickness control of the existing sputtering target systems as described above continue to inhibit the wide use of sputtering as an efficient and cost-effective means for applying surface coatings on large substrates.

A structure and method according to the invention reduces the film thickness anomalies as discussed above.

Where target erosion anomalies occur, a change in the strength of the magnetic field exposed to the target at those locations has been found to improve the uniformity or control the variation in thickness of the deposited film. One way to change the film thickness at any such location is to provide a localized change in the magnetic field strength while maintaining the uniformity of magnetic field strength over the rest of the target area.

A magnet member (the magnetron assembly) is lo-

cated in proximity to the sputtering target, and is provided with a magnetic member cycling system (drive system), which causes the magnet member to move in a set or recurring pattern. The recurring pattern is defined by a set of points defining a pattern reference surface. The pattern reference surface is defined by a set of lateral coordinates and a set of vertical coordinates of the pattern. The lateral coordinates establish a grid defining the lateral locations at which the vertical coordinates define a set of elevations of the pattern reference surface, either on the reference surface or on an offset reference surface (which is parallel to but offset from the reference surface).

The pattern reference surface includes a divergent portion (a preset pattern of relative motion) having a subset of elevations which fall outside a range of tolerance for parallelism between the pattern surface and a reference surface of the sputtering target. Movement of the magnetron in the divergent portion reduces or increases the magnetron field strength at the surface of the target.

The reference surface of the sputtering target can be its front face. It could be a middle axis of the sputtering target, or it could be a back face. It should be obvious to persons of ordinary skill in the art that the intensity of the magnetic field should be approximately equal over the surface of the sputtering target facing the sputtering chamber. Therefore, the definition of the reference surface of a sputtering target can be any surface real or imagined that can be defined generally by geometric or mathematical means as being parallel to the surface of a sputtering target, whether that surface be straight or curved. It is assumed that such a straight or curved surface is a continuous one (without sudden steps) and is generally used as a reference for parallelism before sputtering occurs (an un-used pre-sputtering configuration), because after sputtering has begun the target erosion will deform the shape of the sputtering target and start to generate differences in the uniformity of film thickness due to small, but detectable, differences in the target erosion rate across its surface.

It may be desirable to have uniform film thickness over some portions of the substrate and have varying thicknesses in other regions. The structure and method according to the invention allows control of the film thickness deposited, by varying the strength of the magnetic field. An approximately uniform film thickness can be achieved, but so can a prescribed pattern of film thickness which is not necessarily uniform, for example one which is thicker at the edges to provide an easier connection to external wiring.

In one configuration, a change in the magnetic field strength can be accomplished when using a two bearing rail system merely by tilting opposite corners of opposing rails in opposite directions (the magnetron acting as a bearing truck between the rails). For example, by providing a high end and a low end on one bearing rail while the opposite bearing rail has its low end opposite the

high end of the first bearing rail. Such a tilted configuration will cause a flight path or surface pattern (profile) for the magnetron assembly that includes regions of the surface pattern that fall outside a standard tolerance for parallelism between the magnetron path pattern reference surface and the reference surface of the target. In one configuration the magnetron is tilted in one direction at one end of the back and forth travel, and is tilted in the opposite direction at the opposite end of the back and forth travel. A change in rail elevation as small as 0.020" - 0.030" (500-750 $\mu$ m) in central regions of the travel has a noticeable effect because of the strength of the magnetic field decreases greatly over a small distance. The effect of a change in the elevation of a linear rail of 0.030" end to end of a 2-foot travel path provides an improvement in the variation in film thickness uniformity from approximately 8% to approximately 3-4% (providing a improvement which meets the 5% specification).

In another configuration, according to the invention, it is possible that when utilizing two bearing rails that they be curved or otherwise patterned to move the magnet member (magnetron assembly or one end of the assembly) close to and away from the target surface in a particularly described pattern to increase and decrease the magnetic field strength to promote an improvement in the control or uniformity of the deposited film thickness.

Utilizing a magnet member moving in the transverse (lateral) direction, it is possible to provide several tracks (more than two) to help guide the magnet member. The magnet member (magnetron) can be divided into two or more sub-sections to assist in maintaining a uniform target profile. For example, it is possible to provide three generally parallel bearing rails (a set of tracks) which support two magnet member sub-sections between them. The outside bearing rails can be relatively flat, while the inside bearing rail could dip down or rise up to change the magnetic field intensity. Similarly, the magnet member could be constructed of a series of magnet member sub-sections (connected in a housing or separate from one another) with each magnet subsection following the contour of its own rail or path as it moves from one end to the other end of the processing chamber.

In another configuration, a cam plate surface which includes a series of slots and surface followers which are connected to the subsections of the magnet member. Movement of the magnet member from one end to the other causes the elevation of each separate subsection of the magnet member to follow the pattern of the cam surface. Varying the elevation of various magnet subsections by the use of a mechanical cam surface - follower system can also be reproduced by utilizing vertical activation devices such as motors and vertical drives which cause each magnet member subsection to move vertically according to a pre-programmed contour depending on its lateral location. Such movement could

potentially change the sputtering intensity at the ostensible location of sputtering anomalies, which create an uneven erosion profile, to eliminate such anomalies and improve the film thickness uniformity.

It is known that the distance between the face of the sputtering target and the substrate being sputter deposited is one factor in determining the film thickness deposited on the substrate. However when sputtering large substrates, because the center of the target is farther away from the source of sputtering power, and there tends to be a drop in the sputtering intensity at the center of a large target. Therefore, to compensate for this drop, the magnet field at this location (region) could be gradually increased by moving the magnetron closer to the sputtering target at the center to improve the film thickness uniformity.

Another configuration for improving film thickness uniformity is to tilt (roll or pitch) only the end of the magnetron near the end of its travel. The bearing rails supporting the magnetron are kept straight and level and the end of the magnetron is tilted by utilizing a localized ramp (cam) and roller (cam follower). Either the ramp or the roller is located on the end of the magnetron and the ramp or follower is located on a stationary support fixed to the processing chamber. The lateral motion of the magnetron at a particular location causes the cam to engage the cam follower causing a tilting force to be generated. The tilting force pushes the end of the magnetron in a vertical direction to cause the magnet member reference surface to describe the divergent portion. The tilt can be a roll motion or a pitch motion as the terms roll and pitch are understood when referring to an aircraft's attitude - the magnet member (magnetron) relating to a fixed wing on an aircraft.

Electromagnets can be used in the magnetron and the magnetic field of the electromagnets can be varied to cause changes in the strength of the magnetic field to affect and control the film thickness desired.

A method according to the invention includes the steps of moving a magnet member laterally in the proximity of a sputtering target and moving portions of said magnet vertically, a distance greater than a tolerance for parallelism between a reference plane and the plane of motion at selected locations to vary the magnetic field strength causing a divergence from the plane to improve the film thickness control. Another method according to the invention includes the steps of moving a magnet member laterally along a track and moving portions of the magnet member in a vertical direction simultaneously with the lateral motion of the magnet member to change the magnetic field intensity utilized for sputtering at one or more locations along the track to improve film thickness uniformity for sputtering.

These structures and methods provide a degree of improvement in the control of film thickness not known or utilized in the prior art.

The following is a description of some specific embodiments of the invention, reference being made to the

accompanying drawings, in which:

Figure 1 is a schematic top view of a prior art magnetron enclosure;

Figure 2 is a cross sectional end view of the sputtering chamber separated from the prior art magnetron chamber of Figure 1 by the target assembly; Figure 3 is a side cross sectional view of the apparatus of Figure 2 showing the conceptualized magnetic field of the magnetron extending far beyond the sputtering target;

Figure 4 is a cross sectional view of the magnetron including permanent magnets and a conceptualization of the magnetic field emanating downwardly therefrom;

Figure 5 is a second side cross sectional view of the apparatus of Figure 2 showing the magnetron raised up to a higher elevation with the conceptualized magnetic field from the magnetron just barely extending beyond the sputtering target;

Figure 6 is a prior art target erosion profile showing the pattern of erosion (utilization) of the sputtering target during sputtering;

Figure 7 shows the film thickness profile on a substrate as determined from a sheet resistance analysis using a five point probe (which is inversely proportional to film thickness) for a sputtering target utilizing the prior art magnetron chamber;

Figure 8 is a plot of the film thickness contours of a sputtering target assembly from a sheet resistance analysis using a five point probe (which is inversely proportional to film thickness) when using a structure and method according to the invention;

Figure 9 is a schematic perspective view of a magnetron chamber utilizing a center bearing rail to support the magnetron;

Figure 10 is a schematic representation showing an exaggerated dimension of the center magnetron support beam of Figure 9 and its rotation as it travels along the center beam support;

Figure 11 is a cross sectional view of a magnetron support beam taken at 11-11 of Figure 14;

Figure 12 is a cross sectional view of a magnetron support beam taken at 12-12 of Figure 14;

Figure 13 is a cross sectional view of the magnetron support beam taken at 13-13 of Figure 14;

Figure 14 is a top view of a magnetron chamber according to the invention with a center magnetron support beam;

Figure 15 is a perspective view of a bearing channel beam with bearing tracks (rails) supported on the central beam as shown for example in Figure 9;

Figure 16 is a modified bearing support rail showing the channel being split and being raised one side of each end of the channel to provide the vertical travel of portions of the magnetron;

Figure 17 shows a top plan view of the end of the magnetron as shown in Figure 18 as it about to en-

gage the ramp (cam) to be lifted;  
 Figure 17A shows a top plan view of the end of the magnetron as shown in Figure 18A as it about to engage the ramp (cam) to be lifted;  
 Figure 18 is a partial cross sectional view of a magnetron chamber taken at 18-18 of Figures 20 and 24, showing the ramp which raises the end of the magnetron at opposite ends of the chamber;  
 Figure 18A is a partial cross sectional view of a magnetron chamber taken at 18A-18A of Figures 20A, showing the ramp which tips the edge of the magnetron at opposite ends of the chamber;  
 Figure 19 shows a cross sectional side view showing the position of the ramp in relation to the magnetron;  
 Figure 20 shows the top plan view of the magnetron chamber having a magnetron whose ends are subject to being raised by ramps at opposite corners;  
 Figure 20A shows the top plan view of the magnetron chamber having a magnetron whose ends are subject to being raised by ramps at its corners;  
 Figure 21 shows a schematic cross section of a deformable horizontal magnetron whose end is bent up in a curved shape, taken at 21-21 in Figure 24;  
 Figure 21A shows a schematic cross section of a rigid horizontal magnetron whose end is raised up, taken at 21-21 in Figure 24;  
 Figure 22 is a schematic cross sectional view of the deformable horizontal magnetron, taken at 22-22 in Figure 24;  
 Figure 22A is a schematic cross sectional view of the rigid horizontal magnetron, taken at 22-22 in Figure 24;  
 Figure 23 is a cross sectional view of the deformable horizontal magnetron whose end is bent up, taken at 23-23 in Figure 24;  
 Figure 23A is a cross sectional view of the rigid horizontal magnetron whose end is bent up, taken at 23-23 in Figure 24;  
 Figure 24 is a schematic top view of a magnetron chamber where the magnetron is supported near its center, including ramps at opposite corners to influence the vertical position of the end of the magnetron when the magnetron is moved near either end of its travel;  
 Figure 25 is a bottom plan view of a magnetron chamber utilizing a central beam support for the magnetron track;  
 Figure 26 is a cross sectional view of the magnetron chamber of Figure 25;  
 Figure 27 is a schematic perspective view of a magnetron chamber enclosing a traveling magnetron supported by two horizontal beams near its ends;  
 Figure 28 is a schematic representation of the elevation change (rotation) of the magnetron as it travels one end to the other along inclined tracks as shown in Figure 27;  
 Figure 29 is a schematic cross sectional view of a

magnetron supported from two generally parallel rails (tracks) according to the invention;  
 Figure 30 is a cross sectional view showing the magnetron support rails and magnetron attitude, taken at 30-30 in Figure 33;  
 Figure 31 is a cross sectional view showing the magnetron support rails and magnetron attitude, taken at 31-31 in Figure 33;  
 Figure 32 is a cross sectional view showing the magnetron support rails and magnetron attitude, taken at 32-32 in Figure 33;  
 Figure 33 is a schematic top view of a magnetron chamber where the magnetron is supported near its ends by two horizontal support rails;  
 Figure 34 is a bottom plan view of a magnetron supported along two generally parallel beams at the edges of the magnetron chamber;  
 Figure 35 is a cross sectional end view of Figure 34;  
 Figure 36 shows a cross sectional view of a hinged magnetron in a magnetron chamber, for example as shown in Figure 37;  
 Figure 37 shows a schematic perspective view of a hinged magnetron with a bowed down center track according to the invention;  
 Figure 38 shows a moving magnetron assembly (device) having permanent magnet sub-sections whose vertical travel is influenced by a contour plate which changes the vertical spacing between each magnet sub-section and the target during sputtering as the magnetron moves laterally;  
 Figure 38A shows a moving magnetron assembly (device) having a deformable magnetron connected through several cam follower linkages to a contour plate, the vertical travel of portions of the magnetron connected to the cam follower linkages is influenced by a contour plate which changes the vertical distance between each portion of the magnetron and the target during sputtering as the magnetron moves laterally;  
 Figure 39 provides an alternate conceptualized magnetron reference surface pattern for a contour plate showing high points at the right and left corners and low points at the front and back corners of the conceptualized plate shown;  
 Figure 40 shows a conceptualized magnet reference surface pattern having a lateral central axis in a parabolic or circular concave down type shape with all paths perpendicular to the lateral axis being equal lengths;  
 Figure 41 shows a conceptualized magnet bowl-shaped type parabola pattern plate for use as a magnet section guide, the shape being similar to the shape pictured in Figure 38;  
 Figure 42 shows a conceptualized reference surface pattern convex surface to use as a magnet pattern contour plate;  
 Figure 43 shows a flat magnet contour plate assembly utilizing activators for raising and lowering the

magnet sections individually using electrical or other activators according to a pre-programmed pattern;

Figure 44 shows an magnetron whose magnets are electro-magnets, the strength of the magnetic field is controlled by varying the electrical energy supplied to each electro-magnet segment in the magnetron as the magnetron moves laterally during sputtering; and

Figure 45 shows a cross section of an electro-magnetic magnetron according to the invention as used in the configuration of Figure 44.

An understanding of the improvement the invention provides results from comparison of the film uniformity plots of Figures 7 and 8. In the plot 250 of Figure 7 the plots of the contour shows several heavy black contour lines showing the film thickness variation across areas of the substrate as the thickness is plotted from a center to an edge of the substrate. The non-symmetrical (skewed) plot shows that the upper left corner and the lower right corner depositions include severe variations at those locations. The variation in film thickness uniformity for the analysis of Figure 7 being approximately 8%. In comparison a similar plot 260 using a structure and method according to the invention results in the film uniformity plot as shown in Figure 8. The plot from the analysis is now generally symmetrical about the center and is rectangular without being skewed. The thickness variation from center to the edge being approximately equal on both sides of a vertical center axis. Figure 8 provides a smaller distance between the maximum and the minimum than the plot of Figure 7. The resulting variation in film thickness uniformity being approximately 4%.

#### Single Beam Bearing Support

Figure 9 shows a perspective schematized view of a device according to the invention wherein a magnetron assembly 272 is moved within a magnetron chamber 270 in the direction shown by the arrows 274. The magnetron assembly 272 is supported on a central bearing support beam 276 which can be moved vertically uniformly as shown by the arrows 278. A set of bearing rails, (e.g., 382, 384) supports the magnetron assembly 272 through a set of bearing truck receiving members (e.g., 282). The lateral motion of the magnetron assembly is produced by turning a threaded drive rod 284 which is engaged with a threaded drive nut 286 contained in a threaded drive nut housing 288. The threaded drive nut housing engages and can slide vertically on a pair of connecting pins 290a, 290b, which are fixed to and extend upwardly from the top of the magnetron assembly 272. The sliding connection between the connecting pins 290a, 290b and the threaded drive nut housing 288 accommodates differential vertical motion between the threaded drive rod 284 which is

fixed to the walls of the magnetron chamber 270 and the magnetron 272 supported by the support beam 276. The sliding connection allows vertical motion of a portion of the magnetron as it cycles from end to end and tips as it cycles as shown in Figure 10.

Figure 10 shows an idealized exaggerated schematic perspective view of the motion of the magnetron assembly as shown in Figure 9. The magnetron assembly 300 moves laterally (horizontally in this case, but the lateral motion could be across a curved (e.g., spherical) substrate surface as well) supported on a central bearing support rail 302 showing a twist from end to end. Dashed lines 304, 306 show a change in the elevation of the ends of the magnetron assembly (roll - as that term is understood for aircraft motion) as the magnetron 300 moves laterally from one end of the chamber to the other. As the magnetron assembly 272, 300 moves from one end of the processing chamber to the other, its left and right ends rise and fall, respectively, thus becoming farther from and closer to the target assembly, respectively. The end (a portion) of the magnetron assembly that is farther from the target surface reduces the magnetic field influence enhancing sputtering, while an end of the magnetron that is closer to the target surface increases the magnetic field influence enhancing sputtering. This end to end tilting arrangement provides greater influence on sputtering at opposite corners of opposite ends of the magnetron chamber and magnetron respectively as the member moves from laterally from end to end.

Conventional thinking requires the magnet field strength to be held constant over the whole area of the target as the magnetron moves. Such thinking imposes a specification for flatness of the tracking or parallelism between the path of the magnetron and a reference surface (usually the front surface) of the target. The parallelism between members is intended to provide a constant magnetic field. Specification of the range of the usual tolerance for flatness or parallelism which is usually approximately 5 thousandths of an inch in 1 foot or less, is utilized to help define an aspect of the invention according to the claims. Such tolerances also exclude variations in alignment due to natural variation in manufacturing and practical limits in aligning of mechanically mating pieces. The actual difference in elevation of the ends of the magnetron according to the invention can be quite subtle. Variations in elevation slightly falling outside the natural range of the tolerance of the specification for flatness or parallelism as slight as 0.0075° per foot will have an effect on film thickness uniformity, because the magnetic field strength varies strongly with the distance. A localized variation in elevation will have a localized effect. The localized variation can be defined as a divergent portion (that portion of the reference surface of the magnetron motion that exceeds the tolerance for flatness or parallelism, both of which under normal circumstances are defined as plus or minus 0.005° elevation variation per lateral foot or less, less than 0.05%).

Therefore a configuration according to the invention can be defined in terms of the tolerance for flatness or parallelism. The imaginary surface formed by the lateral and vertical motion of the magnetron is evaluated for flatness or for parallelism against a reference surface. A configuration according to the invention provides that the imaginary surface include a divergent portion which has vertical components of the imaginary surface which fall outside the range of the conventional tolerance for flatness and/or parallelism and as a result of the motion of the magnetron in the divergent portion the motion produces an improvement in the uniformity of film thickness deposited on a substrate. Because the magnetic field strength varies strongly as a function of distance from the magnetron, progressively larger departures from flatness or parallelism create progressively larger changes in the film thickness achieved. A departure from flatness or parallelism of 0.030" at the end of the magnetron track, or as much as approximately 10 mm out of plane at the end of the magnetron, for the configuration of Figure 9, results in changes in film thickness uniformity at opposite corners of the substrate and target which provide an observable improvement when compared to the plot of Figures 7, (the setup in Figure 7 having the normal maximum range of 0.010" from rail end to rail end, when the tolerances for flatness or parallelism are met). The elevation change provides an improvement in film thickness uniformity to meet the specification requirements of a 5% variation, as shown in Figure 8.

While this example provides one configuration of the invention, this same technique can be used at other locations where the film thickness uniformity or thickness control needs to be improved. The motion of the magnetron is adjusted so that the imaginary surface pattern describing its motion includes divergent portions which exceed the normal tolerances for flatness or parallelism and create a change in the magnetic field at the surface of the target being sputtered, so that the film thickness uniformity or thickness control deposited on the substrate is improved.

The vertical motion of a portion exceeding the specification for flatness and for parallelism from end to end and side to side is measured against an imaginary reference surface superimposed on the imaginary reference surface pattern/profile created by the motion of the magnetron assembly 272. An elevation view showing the characteristics of the motion of the magnetron assembly 272 departing from flatness or parallelism is shown in Figures 11, 12, and 13 for tilting of a linear magnetron assembly 272, and in Figures 21, 22, and 30 for the bending of the magnetron assembly 272. In both configurations the ends of the magnetron assembly 272 near the end of its travel is raised to exceed the normal (or otherwise selected) tolerance (e.g., 0.005"/ft, 0.0075"/ft, 0.010"/ft, 0.015"/ft, 0.020"/ft, 0.025"/ft, 0.030"/ft, 0.035"/ft, 0.040"/ft, or 0.050"/ft (producing an approximately 10 mm change in elevation at the end

of the magnetron)) to provide an improvement in the film thickness uniformity or thickness control across the surface of the substrate which is being sputter deposited.

Figure 11, 12, and 13 are progressive sectional cuts showing the attitude (tilt or bend - roll) of a magnetron assembly 272 as it moves from one end to the other end of the magnetron chamber 270 as shown in Figure 9. The center support rail 276 supports a one-piece bearing frame 380 as shown in Figures 9 and 15. Generally speaking, the bearing rails 382, 384 are constructed to be fixed parallel to one another. However, if a portion of the bearing rail as shown in Figure 16 is cut along a split separation 392 in the top of the channel, between the holes pictured therein, and shims typically multiples of 0.010" up to 0.060" depending upon the process, e.g., 0.050", for example 394, 396, are positioned and fixed in place between the center bearing support beam 276 and the one-piece bearing frame 380 on opposite sides at opposite ends. The shims cause a slight vertical bend in the bearing rails 382 and 384. The slight vertical offset 371 (Fig. 13) at the center bearing support is amplified as the magnetron projects further outward towards its end, where the vertical offset is a maximum (approximately 10 mm). The configuration of the bearing rails 382, 384 causes the magnetron assembly 272 to follow the path of the rails. Movement of the magnetron creates a series of points in an imaginary surface pattern (flight path) tracing the position of each point of the magnetron assembly 272 as it moves laterally. Some of the points in the imaginary surface pattern are vertically offset from an imaginary horizontal plane (in which the magnetron assembly would move if its bearing rails were not vertically offset from the neutral axis 368 (see Figure 12) of the lateral motion and intersecting with the pattern of the horizontal reference plane) a distance greater than a tolerance for flatness or parallelism with a reference surface. The vertical adjustment to the bearing rail position can also be done by using vertical slots through which bolts are tightened in the side of the one-piece bearing frame instead of or in addition to the shims 394, 396.

As shown in Figure 13, the offset in the vertical direction of the left side split bearing rail frame 360 in a vertical direction by a distance 370 causes the magnetron assembly to assume a roll attitude as shown by the dashed line 372. The offset of the bearing rail from a central axis 364 is set by a distance 366. Similarly in Figure 11 a right side split bearing rail 362 is shown such that the offset of the bearing rail on the right side from a central axis 368 by a distance 371 (approximately 10 mm) provides a magnetron roll attitude as shown by the dashed line 374. Thus, a small change in elevation near a central support will provide a much larger change in elevation at the extreme end of the magnetron assembly 272 extending out far beyond the central support rail 276.

Figures 17-20, 17A, 18A, 20A, and 21-24 show another configuration of a magnetron supported on a central support beam 276 according to the invention. In this

configuration instead of tilting the bearing rails, the bearing rails are maintained in their original flat horizontal attitude which without interference would provide a planar flat travel path for the magnetron parallel to a reference surface of the target assembly. In this configuration the magnetron assembly 272 is supported not just from the central bearing support beam 276, but as the magnetron assembly approaches the ends of the chamber a cam follower (roller) 442 engages a ramp (cam) 422 so that the end of the magnetron assembly is bent or tilted upwards away from the sputtering target assembly. Ramps 422, 428 are positioned at opposite corners of the chamber, corresponding to the locations on the sputtering target where the excessive erosion anomaly is observed (Fig. 6). In one configuration a rigid generally non-deformable magnetron housing can be used with a spring loaded joint to hold the magnetron to the bearing trucks of the center bearing rails. The springs are loaded to hold the magnetron straight and level with the bearing rails, and to allow hinging with a pivot axis at the center bearing rail when the end of a magnetron comes in contact with a cam to raise it. In another configuration the magnetron housing is made of an easily deformable plastic, rubber or other similar material, with a rigid connection at the center rail to the center bearing truck(s), such that when the magnetron end comes in contact with a cam (i.e., 422) it bends in a curve and to raise the end of the magnetron away from the target assembly. Compare the roll attitudes shown in Figures 21 versus 21A and 23 versus 23A.

Figures 17, 17A, 18, 18A, 19, 20, and 20A are a series of related cross sectional schematic views showing the motion of the end of the magnetron assembly 272 where a cam (ramp) and cam follower (roller) positioned at certain locations causes the whole magnetron or a portion of the magnetron to move toward or away from the target assembly. The magnetron assembly uses a cam follower (roller) 442 and cam surface (ramp) 422 to produce a vertical roll motion with a dimension 432 as shown in Figure 17. The end 440 of the magnetron assembly 272 includes a lift roller assembly frame 444 having a lift roller 442. The lift roller 442 and frame 444 travel with the magnetron assembly 272 at its ends (only one end 440, is shown), and when the lift roller 442 encounters the lift ramp 422 fixed to the chamber through a support fixture (e.g., support block 446), it rolls up the ramp 422 and as it is rolling up the ramp the end of the magnetron assembly is bent up a distance 432. In this configuration the translational force moving the magnetron assembly 272 from end to end also causes an end (e.g., 440) of the magnetron to be bent upwards when the ramps 422, 428 are encountered. The dashed lines, 424, 420, 430 in Figures 21, 22 and 23 represent the idealized bent, straight, and bent attitude (configurations), respectively, of the magnetron assembly 272 as it moves from end to end. In the idealized case, one side of the magnetron assembly 272 remains straight and parallel with the reference surface of the target as-

sembly while the other side is bent up in a curve approximately as shown (the linear horizontal dashed lines are a reference against which the change in elevation at the end of the magnetron assembly can be evaluated), in practice there will be some impact on the free end of the assembly as there is some play between the linear bearings in the truck and the bearing rails and some vertical motion at the free end will occur.

In the top view of Figure 24, probable locations for an upper left corner ramp 422 and a lower right corner ramp 428 are shown (the locations providing elastic bending of the magnetron assembly without excessive material stress - for example when an easily deformable material such as rubber is used). When the magnetron assembly 270 moves from its centrally located horizontal attitude (configuration) 420 taken at 22-22 in Figure 24 to a first end of the chamber as shown by the attitude taken at 21-21, the resulting bending of the magnetron assembly is shown by the dashed line 424 and provides an offset dimension 426 from the center line (e.g., 420) at the end of the magnetron assembly. Similarly when the magnetron assembly 272 moves to the other end of the chamber as shown by the view taken at 23-23, the bent attitude of the magnetron assembly is shown by the dashed 430 provides a dimensional offset 432 from the center line (e.g., 420). In a symmetrical system the vertical offset dimensions 432, 426 due to the bend of the magnetron assembly at the two ends should be nearly identical, however it is possible to have a different vertical offset dimension at each end should empirical data show that such varying offsets are necessary. The control of sputtering to achieve non-uniform film thickness in a prescribed pattern can also be performed.

The illustrations of Figures 17A, 18A, and 20A show the use of four ramps (or cams) 415, 416, 417, 418, with a spring loaded center magnetron connection to the center bearing rails trucks (not shown here). The ends of the magnetron the top view of which is shown in Figure 17A includes two sets of rollers 434, 436 which are located above a side of the magnetron 272a. When the magnetron nears the end of its lateral travel two of its rollers on one side (only one of which is shown, e.g., 434) contacts two ramps (i.e., 415, 418) and the magnetron undergoes an upward pitch to raise the edge of the magnetron nearest to the edge of the chamber by a distance 432a. This edge rise due a change in the pitch (again using an aircraft attitude reference) of the magnetron cause a reduction in the magnetic field at the edge of the target assembly and avoids excessive deposition due to edge effects which might otherwise be present. Thus the magnetron can undergo changes in its roll and pitch attitudes. A change in its yaw attitude would be possible if the bearing tracks were not generally linear or if the bearing trucks included a suspension allowing for some differential motion between adjacent bearing truck on a magnetron.

The conceptualized configurations of magnetron assemblies described above are carried out in practice

by mechanisms as shown in Figures 25 and 26.

Figures 25 and 26 show the bottom and cross sectional views of a magnetron assembly 118 supported by a central bearing support frame 136 consisting of a linear bearing support section 142 and a lateral extension section 144. The linear bearing support section 142 has fixed to each of its sides bearing rails 138, 140 (a set of tracks). The magnetron assembly 118 is supported from the bearing rails 138, 140 through a set of linear rail trucks 120, 121. The linear rail trucks are fixed to the magnetron assembly 118 and slide back and forth on the linear rails 138, 140. The motion of the magnetron assembly in a back and forth (lateral) direction is accomplished by rotation of a threaded drive rod (ball screw) 112, which is received by a ball screw receiving nut 122 that includes a set of nut housing pin receiving holes 126, 128. A set of drive pins extend vertically from the magnetron assembly 118 into the holes 126, 128 to slide vertically to avoid binding in the mechanism due to misalignment between the linear rails 138, 140 and the rotatable threaded drive rod 112. The threaded drive rod is turned by a ball screw drive motor 114 supported outside the chamber top while the second end of the ball screw is supported by a ball screw end bearing 116. In this configuration, the movement of the central bearing support frame 136 in a vertical direction is accomplished by rotating a set of vertically oriented lead screws 148, 150, 152, to which toothed drive belt pulleys have been attached. A drive pulley and motor 156, are linked to the toothed drive belt pulleys by a toothed drive belt 154. When the belt drive pulley and motor 156 are turned, the pulleys 148, 150, 152 turn simultaneously to turn equally pitched lead screws engaged with stationary nuts to move the central bearing support frame 136 up and down while maintaining parallelism between the linear bearing support section 142 and the target.

In a conventional configuration, the horizontal attitude of the magnetron assembly 118 is controlled through the sliding attachment to the very precisely aligned bearing rails 138, 140.

In this way, the movement of the magnetron assembly is uniform and parallel with the usually flat front face of an unsputtered target prior to its being eroded or utilized. This configuration is used for sputtering of relatively small rectangular substrates up to approximately 400 mm X 500 mm in size.

In the instance when the magnetron is to be tilted using a configuration according to the invention, the bearing rails 138, 140 are tilted (for example as shown by the configuration of Figure 22), while the central bearing support frame 136 continues to be moved up and down while being held in a parallel attitude with the target assembly.

A method according to the invention includes vertically moving the magnetron assembly as shown in Figures 25 and 26, as the magnetron assembly moves laterally across the target assembly. However, given the variations in the depth target erosion profile as shown

in Figure 6, a parallel lifting of the magnetron assembly would not provide an improvement in the variation in film thickness uniformity or thickness control over the current vertically fixed arrangement. An alternate arrangement would be to drive each vertical support by separate motor/actuators, to control the vertical motion of the support beams and the magnetron assembly through electronic controls tied to the lateral position of the magnetron assembly.

#### Two Parallel Beam Bearing Supports

For large rectangular substrates approximately 600 mm X 700 mm in size, a second mechanism shown conceptualized in Figures 27, and 28 and in detail in Figures 34 and 35 is utilized.

Figure 27 shows the context of this second mechanism of the invention. A magnetron chamber 310 contains a magnetron assembly 312. The magnetron assembly 312 is supported by two bearing support beams 316, 317, which allow the magnetron assembly 312 fixed to a set of bearing trucks (e.g., 324) to move along a set of bearing rails (e.g., 322) in a lateral direction as shown by the arrows 314. The vertical movement of the bearing support beams 316, 318 is shown by the arrows 320. The lateral motion of the magnetron assembly 312 along the bearing rail 322 is produced by rotation of the threaded drive rod 326 which engages a threaded drive nut 328 contained within a threaded drive nut housing 330. The threaded drive nut housing 330 is fixed to a bowed section of a flexible spring-like connection 332, which is fixed to the magnetron assembly 312 such that misalignment or relative motion between the bearing support beams 316, 318 and threaded drive nut 326 provides a flexible connection in a vertical direction while providing rigidity in a transverse direction. The idealized tracking of the magnetron assembly 312 in the configuration of Figure 27 is shown in Figure 28. In Figure 28 a magnetron assembly 342 is supported on two bearing support rails 344, 346 supported by end frames 348, 350. The end frames 348, 350 in this configuration being level and parallel with each other. The positioning of the left side rail 344 showing a vertical progression of the left end of the magnetron 342 from a lower edge of the frame 348 to an upper edge of the frame 350 at the opposite end. The positioning of the right side bearing support 346 shows vertical progression from an upper edge of the end frame 348 to a lower edge of the end frame 350 at the opposite end.

A magnetron assembly supported by end rails is shown in Figures 29 through 33. Figure 29 shows the cross section of a processing chamber with the magnetron assembly 312 supported by two perimeter support rails 400, 402. This configuration is consistent with the conceptualized visualization of Figures 27 and 28. At one extreme end as can be seen in Figure 30 (taken at the location of 30-30 in Figure 33), the offset of the end of the rail 402 in a vertical direction an amount shown



by the distance 406a results in a magnetron assembly attitude (tilt) as shown approximated by the dashed line 412. At a central location as can be seen in Figure 31 (taken at the location of 31-31 in Figure 33) a horizontal attitude 404 configures the magnetron to be parallel with the target surface or target reference surface (usually a plane). At the second end of the processing chamber as shown in Figure 32, the cross section taken at 32-32 of Figure 33, the position of the bearing rail 400 above the reference plane (e.g., parallel to 404 in Figure 31), of the target assembly causes the attitude (tilt) of the magnetron assembly 312 to be approximately as shown by the dashed line 414. The vertical offset distance is represented by 405b. In the instance the horizontal offset from a lateral center line 405 of the processing chamber is a distance 410, therefore the vertical offset dimensions at the beam 405a-405b must be larger to achieve a similar change in attitude (tilt) when compared to the configuration of the magnetron assembly as is shown in Figures 11 through 17 where a smaller vertical offset at the bearing rail located closer to the opposite support rail results in a smaller attitudinal change (tilt) per unit length from one end to the other end of the magnetron assembly 312.

The detailed view of Figures 34 and 35 show a magnetron assembly 170 implemented in a magnetron chamber to be with a sputtering chamber. A magnetron assembly 170 is supported on a set of two bearing rails 206, 208, which are supported on a set of pseudo parallel edge bearing supports 195, 200. A set of linear rail trucks 150, 152 are on the bearing rails 206, 208, and move back and forth, driven by a threaded drive rod (ball screw) 172, which is shown by a dashed line in Figure 34. In this instance, the back and forth motion of the magnetron assembly 170 is accomplished by the rotation of the drive rod 172, mounted between a ball screw drive motor 174 and a ball screw end bearing 176. The ball screw 172 is on a ball screw receiving nut 184 captured in a ball screw nut receiving housing 186. The ball screw receiving housing 186 is fixed to a flexible leaf spring-like element 178, which is connected to the magnetron assembly 170 at its ends. The bearing rails 206, 208 and the above mentioned mechanism are precisely aligned to be parallel with one another and with the face of the sputtering target so that uniform deposition can take place on the base plate.

The magnetron assembly of Figures 34 and 35 is supported on bearing supports 195, 200 aligned to one another to act as a track together with a set of end support frame members 210, 212, 214. To provide vertical adjustment, four bearing mounted threaded support rods engaged with thread receiving nuts on the frame are fixed to toothed pulleys 210, 212, 214 and 216. A toothed drive belt 222 runs around the toothed pulleys 210, 212, 214, and 216 and around to idler pulleys 218, 220 to engage and be driven by a belt drive pulley and motor 224. When the belt drive pulley and motor 224

turn, each of the lead screws in the four corners are turned by the toothed pulleys fixed to the lead screws to cause parallel adjustment of the bearing support frame in a vertical direction. An alternate arrangement would be to drive each vertical support by separate motor/actuators, to control the vertical motion of the support beams and the magnetron assembly through electronic controls tied to the lateral position of the magnetron assembly.

#### Two-Piece Hinged Magnetron

Another configuration for a magnetron assembly 460 and its vertical manipulation is shown in Figures 36 and 37. These Figures show a cross section of a hinged magnetron assembly 460 utilizing a center support rail 462 which can be continuously bent as shown in Figure 37 or can be a series of linear segments. In these configurations a center intersection of the two hinged sections of the magnetron assembly 460 are supported from the center bearing rail 462 to provide variations in the distance from the sputtering target to the center of the magnetron assembly 460 as the magnetron assembly cycles from end to end. The variation in horizontal distances due to the different horizontal dimensions when comparing a hinged magnetron and a straight magnetron is accommodated by curving the perimeter bearing beams inward or by providing a fixed connection between the a bearing truck attached to the center support rail 462 while the bearing truck connections to the side support rails 464, 466, are free to move (slide) toward and away from the center bearing rail 462, details of such connections can be developed and executed by persons of ordinary skill in the art.

#### Segmented Magnetron Following Reference Contour

Another embodiment according to the invention is pictured in Figure 38. In this embodiment one or more cam surfaces and cam followers are utilized to change the distance between portions of a magnetron assembly having magnetron sub-sections which can move independently while maintaining a semblance of a continuous loop of adjacent permanent magnets in the magnet array in the magnetron. The magnet sub-sections (a series of magnet member subsections) can be pivotable and can be hinged together like a chain, to provide a continuous magnetic field, or can be encased in a flexible housing. As shown in Figure 38, several cam surfaces (a series of cam surfaces) can be combined to form a continuous cam surface plate 476 reflecting the profile/pattern to be followed by each sub-section of the magnetron and the magnetron assembly as a whole. The cam surface plate 476 includes several adjacent cam surface slots (e.g., 478) through which a cam follower rod (e.g., 474) connects a cam follower (e.g., 482) with a sub-section (e.g., 472) of the magnetron assembly. A magnetron contour tracking frame 486 maintains

the vertical alignment between the cam followers (e.g., 482) and magnetron sub-sections (e.g., 472) so that they track together (as driven by a lateral drive) to provide an improvement in the control of film thickness and/or its uniformity. Each track of the profile-surface pattern varies the distance between each particular sub-section (e.g., 472) of the magnetron assembly and the target below.

Another configuration according to the invention is shown in Figure 38A. In Figure 38A a magnetron 488 is constructed of a flexible material such that each vertical control member (of a series of vertical drives) controls the vertical elevation of a portion of the magnetron 488. The tracking frame 486 is cut away for clarity. In this configuration, the influence of the magnetron 488 on the target can be precisely controlled, by increasing the number of vertical control members (push/pull rods) and/or by providing such vertical control members on each side of the magnetron so that a desired pitch attitude can be achieved.

Figures 39-42 show conceptualized idealized approximations of three of a variety of surface patterns/profiles that might be utilized for the cam surface 476.

In Figure 39 a surface pattern/profile has a shape similar to the surface pattern/profile tracked by the magnetron assembly of the configuration as shown in Figures 9-15 (opposite corners being high, while adjacent opposite corners are low). In this profile a back corner 494 and a front corner 498 are low, while a right side corner 492 and a left side corner 496 are raised. Therefore, the elevation change between the rails which ostensibly connect the bottom corner 498 with the right corner 492 is from low to high, while the rail which connects from back corner 494 to left corner 496 is from high to low.

Figure 40 shows a surface following a two dimensional circular or parabolic shaped curve. A high point of the curve and the arc shaped surface is along the center lateral axis 503. In practice, a bearing rail elevation would follow a edge of the pictured surface, for example from the right corner 504 to the bottom corner 510 and from the top corner 506 to the left hand corner 508.

The surface profile/pattern contour of Figure 41 shows an upwardly parabolic or rounded type shape where all of the corners, right corner 516, back corner 518, left corner 520, and front corner 522 are approximately at equal high elevations, while a center 515 of the corners is at a low point. A magnetron assembly following this surface pattern will have magnet sub-sections in the magnet array of the a magnetron assembly which cause the center portion of the magnet array to approach the back of the target to increase the sputtering at that location. Alternately, the configuration may be used so that the magnetic field effect uniformly sputters a circularly or parabolically shaped target to sputter deposit a similarly shaped circularly or parabolically shaped substrate (e.g., a parabolic mirror) without hav-

ing to form a specially shaped magnetron. In using this configuration the deposition film thickness can be kept relatively constant utilizing a magnetron sub-section surface pattern/profile as shown by Figure 41.

5 Figure 42 shows a concave down circular or parabolic surface shape with four corners 528, 530, 532 and 534 being the low point of the surface profile/pattern, while a high point of the surface profile/pattern is at a center 527.

10 A person of ordinary skill in the art will understand that the mechanical cam shape (e.g., of Figure 38) or any generally reasonably continuous cam surface profile/pattern can be utilized to change the distance between the magnetron sub-sections and the target assembly. The surface patterns/profiles shown are but  
15 several of the many varieties of surface patterns that might be utilized. Variations in the cam surface/profile can accommodate desired localized changes in the sputtering rate at those particular locations by forming  
20 the cam surface accordingly.

#### Vertical Actuators

Another configuration of the device according to the  
25 invention is to utilize a planar follower plate 546 which utilizes an approximately flat plate and a structure which correlates a lateral position and a vertical position of each sub-section (e.g., 542) of the magnetron as shown in Figure 43. Each sub-section (e.g., 542) is connected  
30 through a vertical positioning rod (e.g., 544) to a contour plate follower activator (e.g., 552). These collectively makeup an activator assembly (e.g., 550). The activator assembly (e.g., 550) moves in a slot (e.g., 548) in the planar follower plate 546 according to the motion of a  
35 magnetron contour tracking frame 558 (shown in dashed lines) which ties all of the activator assemblies together so that they move simultaneously in a lateral direction as the magnetron assembly (including all of the magnetron sub-sections) sweeps laterally across the  
40 target assembly. The vertical position of each magnetron sub-section 542 is set according to a control system 554 which receives elevation control data which establishes an elevation for each magnetron sub-section location as the magnetron cycles from end to end. The  
45 elevation control data causes the magnet sub-sections to moves in a programmed manner according to a programmed surface profile/pattern. The programmed pattern causes the magnet sub-section to move as if it were following a surface pattern of a mechanical cam surface  
50 (i.e., as shown in Figure 38) utilizing electronic programming to cause the activators to move the magnetron sub-sections according to programming of a contour generator 556, which provides a reference contour to the control system 554. The programming of the contour  
55 data is easily changed to adjust the magnetron tracking according to a desired surface pattern/profile.

### Electro-Magnet Magnetron Control of Sputtering

Figures 44 and 45 show a magnetron configuration using electro-magnets which can be used to control sputtering. A magnetron 560 held in a plane generally parallel to a target's surface is swept back and forth across the back of a target assembly. As the magnetron 560 is moved electromagnets in the magnetron are energized and the intensity of the magnetic field generated by each electro-magnet in the array is varied according to a contour plot 556a which sets out the desired film deposition profile based on empirically derived knowledge of variations in the physical configuration. Thus as the magnetron moves back and forth the magnetic field is electrically varied to achieve a result similar to that achieved by moving a magnetron with permanent magnets closer to and further away from the back of the target assembly. The magnet array in such a configuration may include a combination of permanent and electro-magnets, and such electro magnets may be used in conjunction with a vertical motion or with motion in a plane. In the extreme, a static array of electromagnets could have an area covering the substrate surface and the movement of magnetic field would be electronically controlled by controlling the energization and deenergization of selected electromagnets.

Figure 45 shows a configuration of the magnetron 560 utilizing electro-magnets. The magnets are aligned in the same way as shown in Figure 4 except that each permanent magnet segment is replaced by an electro-magnetic core (preferably iron) possibly in the shape of a spool 564 as shown, with each spool 564 being surrounded by a wire coil 568. The strength of the magnetic field is individually controlled by circuit wires 576 connected to the contour controller 554a. As the magnetron travels back and forth the magnetic field strength is varied by changing the electrical power supplied to the electromagnet coils and sputtering is enhanced accordingly.

A method according to the invention for selectively controlling the film thickness deposited on a substrate during sputtering includes the steps of moving a magnet member laterally in the proximity of a sputtering target and varying the strength of the magnetic field enhancing sputtering at the target surface as the magnet member moves laterally to deposit a particular film thickness pattern on the substrate during processing during sputtering. It may be desirable to have a different than uniform film thickness. For example it may be desirable to increase the film thickness at the edge of the substrate so that wiring connections between the conductive layers deposited on the substrate have an increased durability and are less subject to fracture. In general it is expected that the tolerances for film thickness uniformity over a substantial portion of the substrate will have to be maintained, whether localized anomalies in film thickness are desired or not. The structure and method according to the invention provides uniformity where uniformity in film

thickness is desired and provides non-uniformity where non-uniformity is desired

A method according to the invention utilizes moving magnet sections or magnetron assemblies laterally while utilizing a vertical support which changes the elevation of particular portions of the magnetron assembly according to its lateral position to improve film thickness uniformity.

A method according to the invention includes the steps of moving a magnet member laterally in the proximity of a sputtering target and moving portions of said magnet vertically, a distance greater than a tolerance for parallelism between a reference plane and the plane of motion at selected locations to vary the magnetic field strength causing a divergence from the plane to improve the film thickness uniformity. Another method according to the invention includes the steps of moving a magnet member laterally along a track and moving portions of the magnet member in a vertical direction simultaneously with the lateral motion of the magnet member to change the magnetic field intensity utilized for sputtering at one or more locations along the track to improve film thickness uniformity or thickness control for sputtering. The magnet member can be moved laterally along a track and while portions of the magnet member are moved in a vertical direction simultaneously with the lateral motion of the magnet member to change the magnetic field intensity utilized for sputtering at one or more locations along the track to improve the control of the film thickness deposited during sputtering.

In a method according to the invention the step of varying the strength of the magnetic field includes changing the strength of electro-magnets in the magnetic member according to a pattern depending on the lateral location of the magnet member.

While the invention has been described with regards to specific embodiments, those skilled in the art will recognize that changes can be made in form and detail without departing from the spirit and scope of the invention.

### Claims

1. A magnetron sputtering apparatus, comprising:
  - a magnet member having a magnetic field emanating therefrom disposed in the proximity of a sputtering target,
  - a magnet member cycling system which during sputtering of said sputtering target causes said magnet member to move in a set pattern, wherein said set pattern of motion is defined by a set of points defining a pattern reference surface, wherein the pattern reference surface is defined by a set of lateral coordinates and a set of vertical coordinates of the pattern, wherein said set of lateral coordinates establish

- a defined set of locations on an offset reference surface which is approximately parallel to a reference surface of said sputtering target and offset from it,  
 wherein said set of vertical coordinates establish a defined set of elevations for said set pattern at each respective lateral coordinate of said set of lateral coordinates,  
 wherein said pattern reference surface includes a divergent portion having a subset of said defined set of elevations establishing the elevation of the pattern reference surface within said divergent portion at a distance from said offset reference surface at each respective lateral coordinate of said set of lateral coordinates, wherein the elevation of the pattern reference surface within said divergent portion falls outside a range of tolerance for parallelism between said offset reference surface and said reference surface of said sputtering target.
2. The magnetron sputtering apparatus as in Claim 1, wherein motion of said magnet member following said divergent portion of said pattern reference surface, rather than following a non-divergent portion of said pattern in which said distance would fall within the range of tolerance for parallelism between offset reference surface and said reference surface of said sputtering target, provides an improvement in the uniformity or thickness control of film thickness deposited on the surface of a substrate, located opposite said sputtering target, being sputter deposited.
  3. The magnetron sputtering apparatus as in Claim 1, wherein said reference surface of said sputtering target is defined by unused pre-sputtering configuration surface of said sputtering target facing said processing chamber.
  4. The magnetron sputtering apparatus as in Claim 2, wherein said reference surface of said sputtering target is defined by an unused pre-sputtering configuration of a front surface of said sputtering target facing said processing chamber.
  5. The magnetron sputtering apparatus as in Claim 1, 2, 3, or 4,  
 wherein said tolerance for parallelism is 0.0075 inches per foot of motion along said offset reference surface.
  6. The magnetron sputtering apparatus as in Claim 1, 2, or 3,  
 wherein said tolerance for parallelism is 0.010 inches per foot of motion along said offset reference surface.
  7. The magnetron sputtering apparatus as in Claim 1, 2, or 3,  
 wherein said tolerance for parallelism is 0.015 inches per foot of motion along said offset reference surface.
  8. The magnetron sputtering apparatus as in Claim 1, 2, or 3,  
 wherein said tolerance for parallelism is 0.020 inches per foot of motion along said offset reference surface.
  9. The magnetron sputtering apparatus as in Claim 1, 2, or 3,  
 wherein said tolerance for parallelism is 0.025 inches per foot of motion along said offset reference surface.
  10. The magnetron sputtering apparatus as in Claim 1, 2, or 3,  
 wherein said tolerance for parallelism is 0.030 inches per foot of motion along said offset reference surface.
  11. The magnetron sputtering apparatus as in Claim 1, 2, or 3,  
 wherein said tolerance for parallelism is 0.035 inches per foot of motion along said offset reference surface.
  12. The magnetron sputtering apparatus as in Claim 1, 2, or 3,  
 wherein said tolerance for parallelism is 0.040 inches per foot of motion along said offset reference surface.
  13. The magnetron sputtering apparatus as in Claim 1, 2, or 3,  
 wherein said tolerance for parallelism is 0.050 inches per foot of motion along said offset reference surface.
  14. The magnetron sputtering apparatus as in Claim 1,  
 wherein said set pattern of said cycling system results from a motion along a set of tracks supporting and guiding the magnet member,  
 wherein the configuration of said set of tracks establishes said set of lateral coordinates and said set of vertical coordinates of said set pattern, including said divergent portion.
  15. The magnetron sputtering apparatus as in Claim 14,  
 wherein said motion along said set of tracks is a back and forth motion.
  16. The magnetron sputtering apparatus as in Claim 1,

further comprising:

a set of tracks supporting and guiding the magnet member  
 a cam surface fixed to a first of either said magnet member or a fixed support adjacent said tracks and a cam follower fixed to a second of either said magnet member or said fixed support,  
 wherein a divergent portion of said motion, corresponding to said divergent portion of said pattern reference surface, results from a motion along said set of tracks,  
 wherein said set pattern of said cycling system results at least partially from a motion along said set of tracks where during said set motion said cam follower comes into contact with said cam surface and urges said magnet member in a vertical direction to follow a motion corresponding to the divergent portion of said pattern reference surface.

17. The magnetron sputtering apparatus as in Claim 1,

wherein said magnet member includes a series of magnet member subsections,  
 wherein said magnetron apparatus further comprises:

a set of tracks, wherein each one of said set of tracks supports and guides a corresponding subset of said series of magnet member subsections,  
 a series of cam surfaces, each one of said series of cam surfaces being fixed to a first of either a subsection of said series of magnet member subsections or a fixed support adjacent said tracks and a cam follower fixed to a second of either a subsection of said series of magnet member subsections or said fixed support,

wherein a divergent portion of said motion, corresponding to said divergent portion of said pattern reference surface,  
 wherein said set pattern of said cycling system results at least partially from a motion along said set of tracks where during said set motion said cam follower comes into contact with said cam surface and causes at least one of said series of magnet member sections to move in a vertical direction to follow a motion corresponding to the divergent portion of said pattern reference surface.

18. The magnetron sputtering apparatus as in Claim 17,

wherein said series of cam surfaces form a

continuous cam plate surface.

19. The magnetron sputtering apparatus as in Claim 18,

wherein travel of said magnet member following said divergent portion, rather than following said plane, provides an improvement in the uniformity of film thickness deposited on the surface of a substrate, located opposite said sputtering target, being sputter deposited.

20. The magnetron sputtering apparatus as in Claim 18 or 19,

wherein said tolerance for parallelism is 0.0075 inches per foot of motion along said track.

21. The magnetron sputtering apparatus as in Claim 18 or 19,

wherein said tolerance for parallelism is 0.010 inches per foot of motion along said track.

22. The magnetron sputtering apparatus as in Claim 18 or 19,

wherein said tolerance for parallelism is 0.015 inches per foot of motion along said track.

23. The magnetron sputtering apparatus as in Claim 18 or 19,

wherein said tolerance for parallelism is 0.020 inches per foot of motion along said track.

24. The magnetron sputtering apparatus as in Claim 18 or 19,

wherein said tolerance for parallelism is 0.025 inches per foot of motion along said track.

25. The magnetron sputtering apparatus as in Claim 18 or 19,

wherein said tolerance for parallelism is 0.030 inches per foot of motion along said track.

26. The magnetron sputtering apparatus as in Claim 18 or 19,

wherein said tolerance for parallelism is 0.035 inches per foot of motion along said track.

27. The magnetron sputtering apparatus as in Claim 18 or 19,

wherein said tolerance for parallelism is 0.040 inches per foot of motion along said track.

28. The magnetron sputtering apparatus as in Claim 18 or 19,

wherein said tolerance for parallelism is 0.050 inches per foot of motion along said track.

29. An magnet scanning mechanism comprising:

- a magnet member supported on series of rails, where the magnet member acts as a truck that rides said series of rails, wherein said rails run adjacent to one another to accommodate an approximately constant track width of said truck as it moves from a first end of said series of rails to a second end of said series of rails, wherein said movement of said magnet member as it moves from said first end of said series of rails to said second end of said series of rails describes a reference surface, wherein said reference surface diverges from flatness by dimensional tolerances greater than a range of tolerance for flatness.
30. The magnetron sputtering apparatus as in Claim 29, wherein said tolerance for flatness is 0.0075 inches per foot of motion along said rails.
31. The magnetron sputtering apparatus as in Claim 29, wherein said tolerance for flatness is 0.010 inches per foot of motion along said rails.
32. The magnetron sputtering apparatus as in Claim 29, wherein said tolerance for flatness is 0.015 inches per foot of motion along said rails.
33. The magnetron sputtering apparatus as in Claim 29, wherein said tolerance for flatness is 0.020 inches per foot of motion along said rails.
34. The magnetron sputtering apparatus as in Claim 29, wherein said tolerance for flatness is 0.025 inches per foot of motion along said rails.
35. The magnetron sputtering apparatus as in Claim 29, wherein said tolerance for flatness is 0.030 inches per foot of motion along said rails.
36. The magnetron sputtering apparatus as in Claim 29, wherein said tolerance for flatness is 0.035 inches per foot of motion along said rails.
37. The magnetron sputtering apparatus as in Claim 29, wherein said tolerance for flatness is 0.040 inches per foot of motion along said rails.
38. The magnetron sputtering apparatus as in Claim 29,
- wherein said tolerance for flatness is 0.050 inches per foot of motion along said rails.
39. A magnetron scanning apparatus comprising: a magnet member running as a truck on a set of separated linear bearing rails which are approximately parallel, where during sputtering to improve the uniformity of film thickness sputter deposited on a substrate opposite a target disposed between said target assembly and said magnet member a first end of a first rail of said set of bearing rails is raised to be further from the target than a second end of said first rail of said set of bearing rails.
40. A magnetron scanning apparatus as in Claim 39, where during sputtering to further improve the uniformity of film thickness sputter deposited, a second end of a second rail of said set of bearing rails is raised to be further from the target than a first end of said second rail of said set of bearing rails, wherein said second end of said second rail of said set of bearing rails corresponds to said second end of said first rail of said set of bearing rails.
41. A magnetron sputtering apparatus as in Claim 40, wherein a set of vertical positions of said first and said second ends of said rails is set by a vertical travel mechanism which can raise and lower said first and said second ends of said first and second rails to set the tracking of the magnet member.
42. A magnetron sputtering apparatus as in Claim 41, wherein said vertical travel mechanism operates during sputtering and tracking of said magnet member.
43. The magnetron sputtering apparatus as in Claim 18, wherein said magnet member includes a series of magnet member subsections, wherein movement along said track results from a programming of a motor to raise and lower each subsection of said set of subsections according a programmed pattern depending on the lateral position of said magnet member as it moves laterally.
44. The magnetron sputtering apparatus as in Claim 18, wherein the magnet member includes at least two section with a center track of said set of tracks supporting an end of each section of said at least two sections, said magnet member appearing to be hinged at said center track.
45. A magnetron apparatus comprising: a magnet member supported on two rails set

- at a selected amount of non-parallelism.
46. A magnetron member comprising:  
 a magnet member supported on two rails, selectively controllable in an amount of non-parallelism during a scanning of the magnet member. 5
47. A method for selectively controlling the film thickness deposited on a substrate during sputtering comprising the steps of: 10
- moving a magnet member laterally in the proximity of a sputtering target and  
 varying the strength of the magnetic field enhancing sputtering at the target surface as the magnet member moves laterally to deposit a particular film thickness pattern on the substrate during processing during sputtering. 15
48. The method for selectively controlling the film thickness deposited on a substrate during sputtering as in Claim 47, 20
- wherein the step of varying the strength of the magnetic field includes moving portions of said magnet member vertically. 25
49. The method for selectively controlling the film thickness deposited on a substrate as in Claim 48, 30
- wherein the step of moving portions of the magnet member vertically provides that the vertical distance is a distance greater than a tolerance for parallelism between a reference plane and the plane of motion at selected locations to vary the magnetic field strength causing a divergence from the plane to control the film thickness uniformity. 35
50. The method for selectively controlling the film thickness deposited on a substrate during sputtering as in Claim 47, 40
- wherein the step of varying the strength of the magnetic field includes changing the strength of electro-magnets in said magnetic member according to a pattern depending on the lateral location of the magnet member. 45
51. A method for selectively controlling the film thickness deposited on a substrate during sputtering comprising the steps of: 50
- moving a magnet member laterally along a track and  
 moving portions of the magnet member in a vertical direction simultaneously with the lateral motion of the magnet member to change the magnetic field intensity utilized for sputtering at one or more locations along the track to improve the control of the film thickness deposited during sputtering. 55
52. A method for selectively controlling the film thickness deposited on a substrate during sputtering comprising the steps of:
- locating a magnetic field opposite a sputtering target;  
 moving the magnetic field laterally across the target;  
 varying the strength of the magnetic field at locations where a localized change in the deposited film thickness is desired.
53. The magnetron sputtering apparatus as in Claim 1, 15
- wherein said magnet member includes a series of magnet member subsections,  
 wherein said magnetron apparatus further comprises:
- a set of tracks, wherein each one of said set of tracks supports and guides a corresponding subset of said series of magnet member subsections as a lateral drive moves each one of said series of magnet member subsections in a lateral direction, a series of vertical drives, each one of said series of vertical drives being fixed to provide relative motion between each respective subsection of said series of magnet member subsections and said lateral drive, 20
- wherein a divergent portion of said motion, corresponding to said divergent portion of said pattern reference surface,  
 wherein said recurring pattern of said cycling system results at least partially from a vertical motion provided by said vertical drive as a result of programming the control of said vertical drive to provide a preset pattern of relative motion corresponding to the divergent portion of said pattern reference surface. 25
54. A magnetron sputtering apparatus comprising: 30
- a sputtering target assembly having a first side opposite a second side wherein a target surface on said first side is exposed to a sputtering chamber;  
 a traveling magnet member disposed to travel along a track on a second side of said target assembly, said magnet member including components which produce a magnetic field extending beyond the surface of said magnet member toward said target surface. 35
- wherein a portion of said magnet member travels in a plane approximately parallel to an unused pre-sputtering configuration of said surface of said first side of said target, except in a

divergent portion, where the distance of a portion of the magnetic member and said unused configuration of said surface of said first side of said target assembly exceed a range of tolerance for parallelism between said plane and said unused pre-sputtering configuration of said surface of said first side of said target.

5

10

15

20

25

30

35

40

45

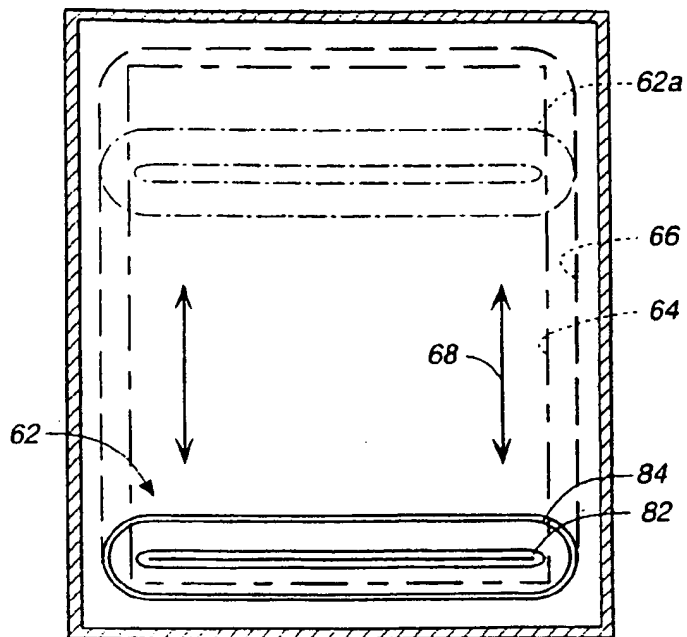
50

55

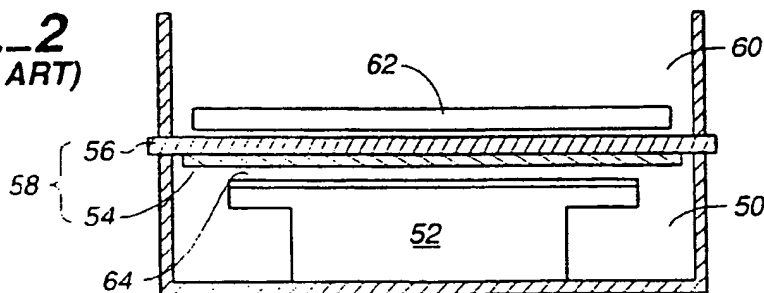
18



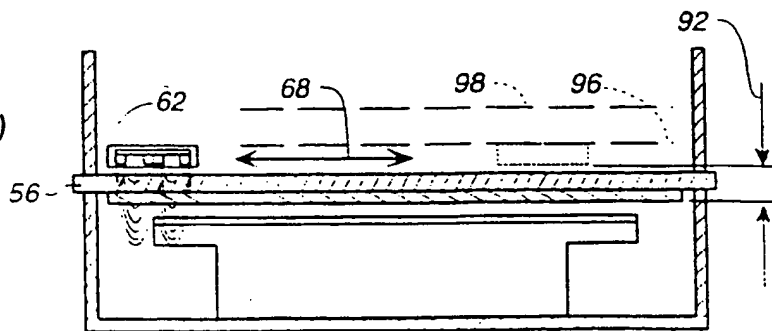
**FIG. 1**  
(PRIOR ART)

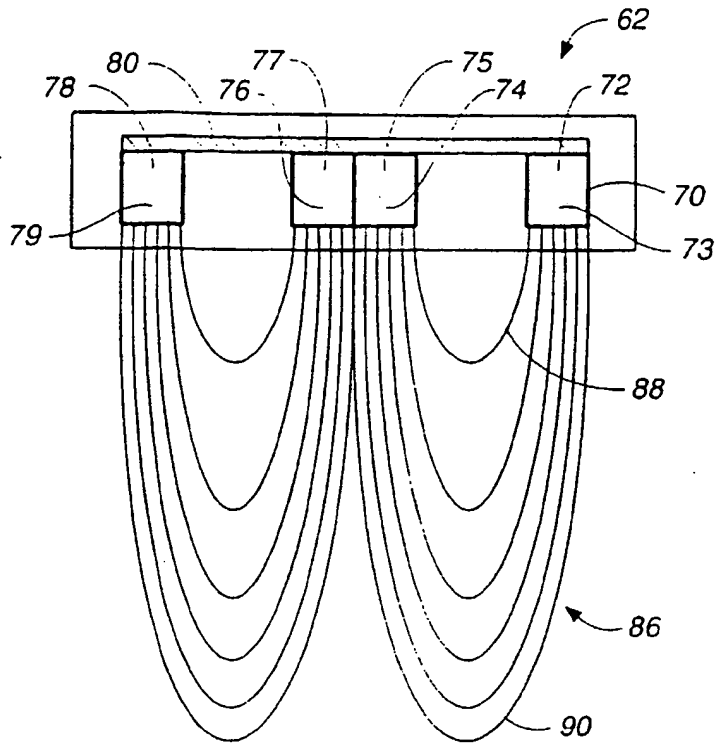


**FIG. 2**  
(PRIOR ART)

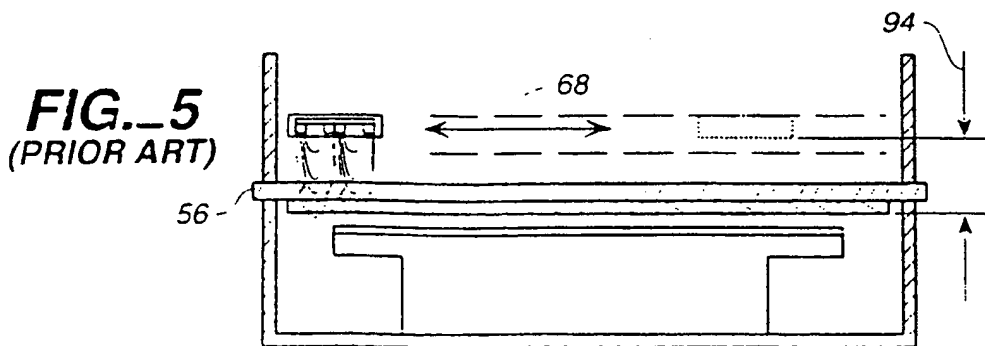


**FIG. 3**  
(PRIOR ART)

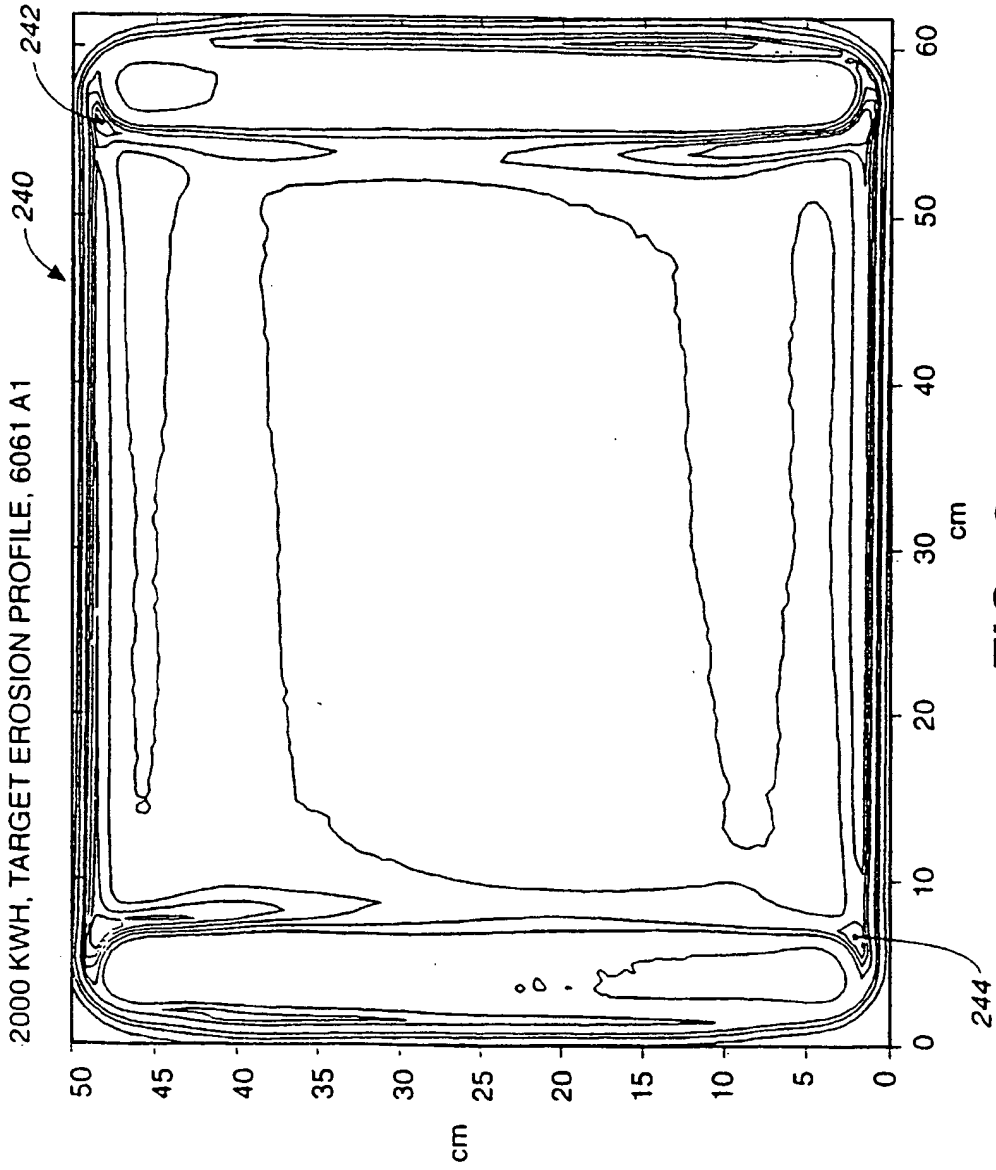




**FIG. 4**  
(PRIOR ART)

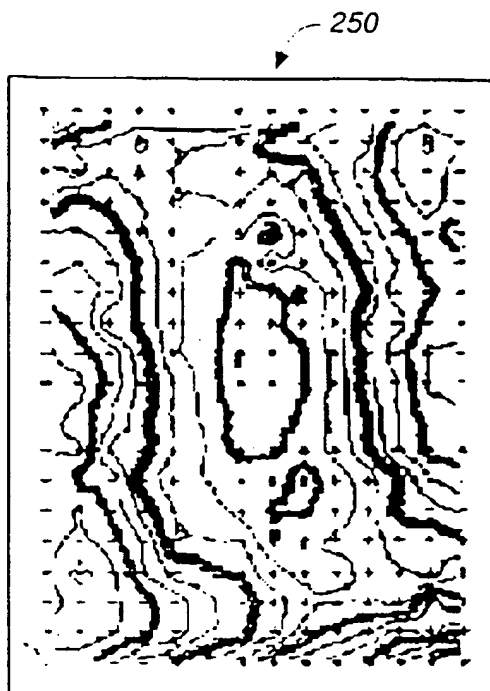


**FIG. 5**  
(PRIOR ART)

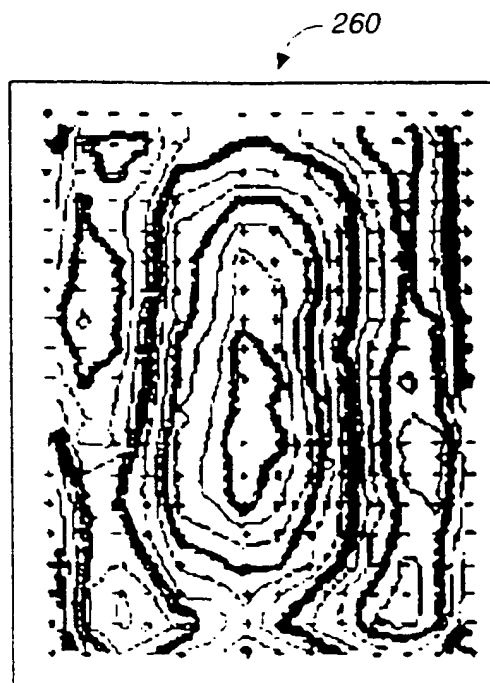


**FIG. 6 (PRIOR ART)**

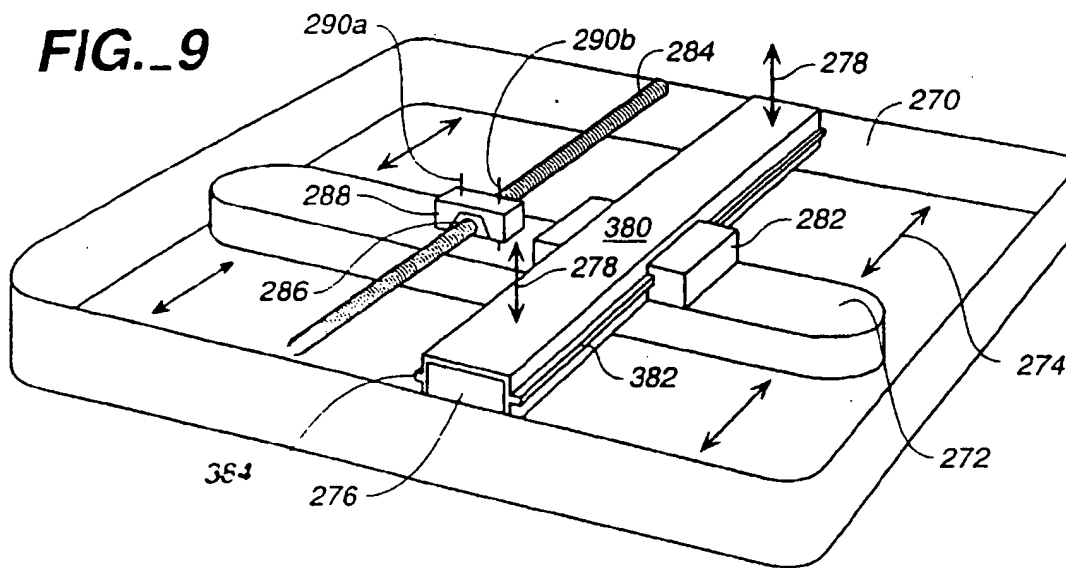
**FIG.\_7**  
**(PRIOR ART)**



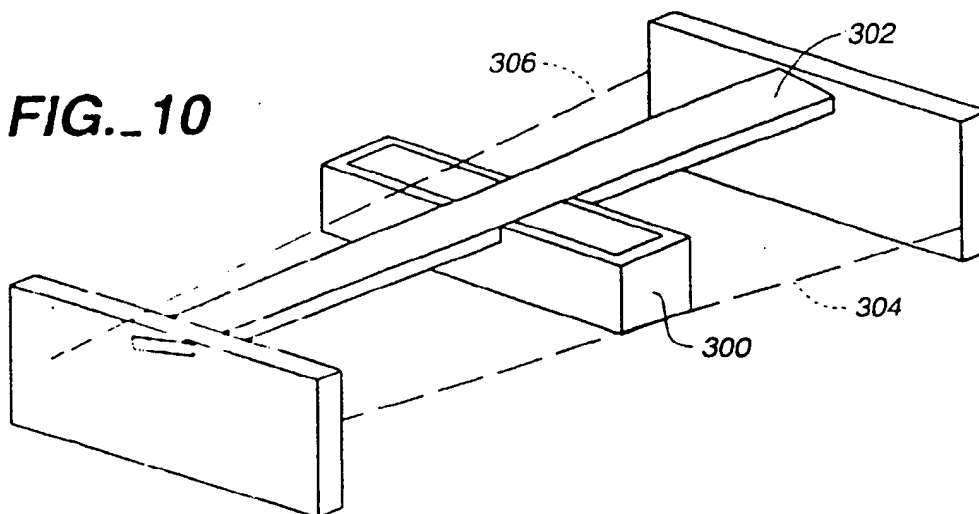
**FIG.\_8**



**FIG. 9**



**FIG. 10**



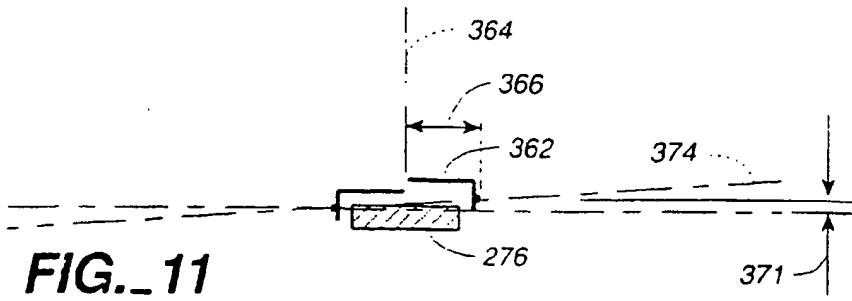


FIG. 11

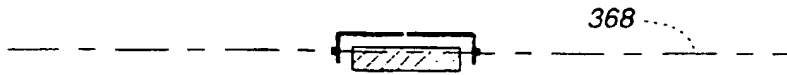


FIG. 12

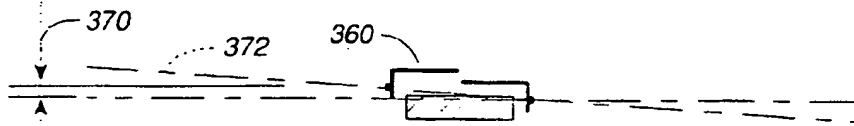


FIG. 13

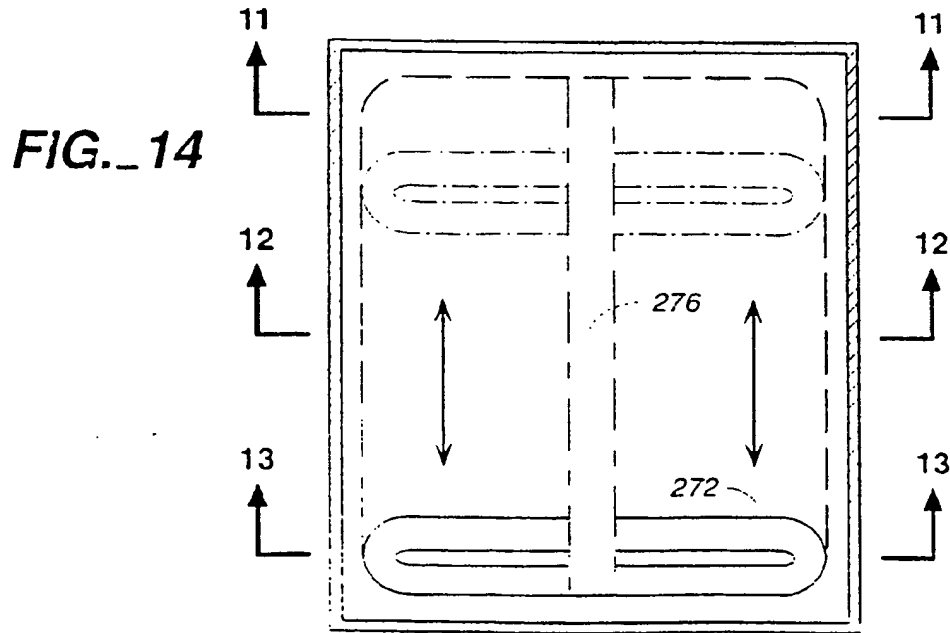


FIG. 14

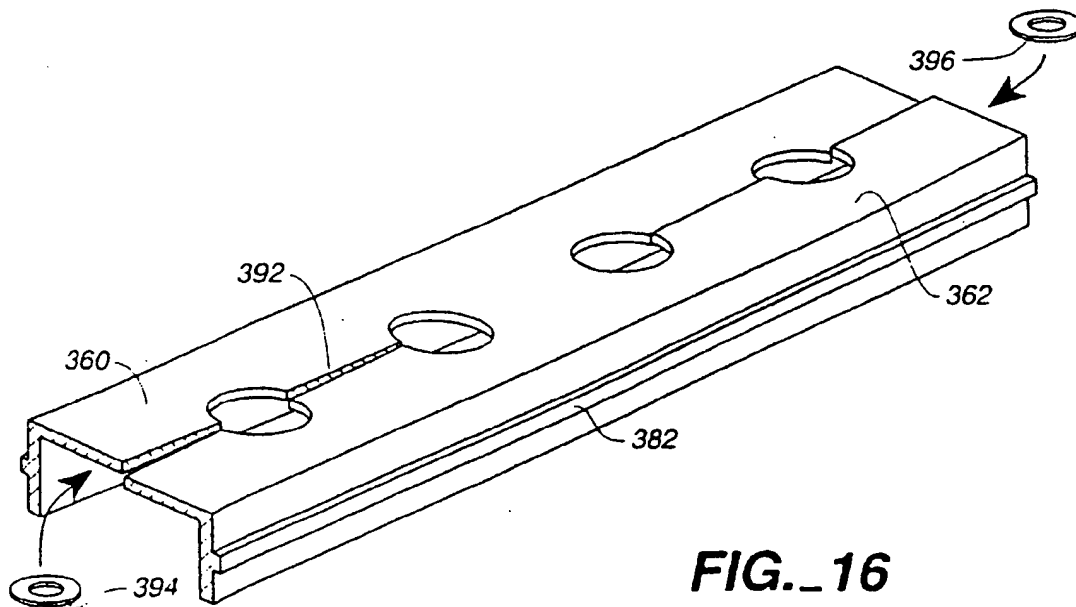
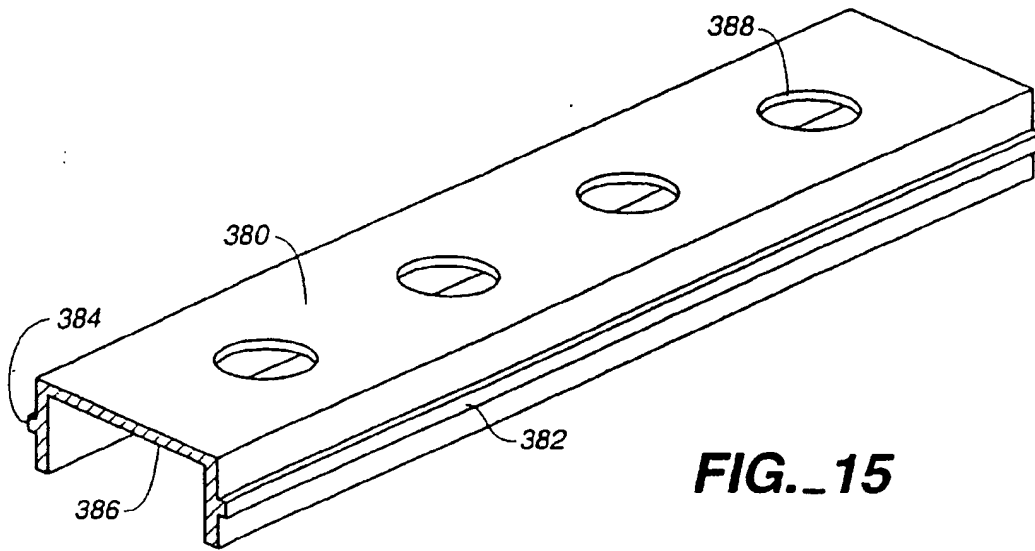


FIG.\_17

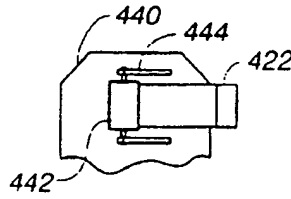


FIG.\_18

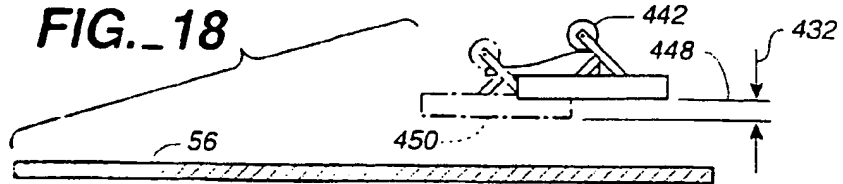


FIG.\_19

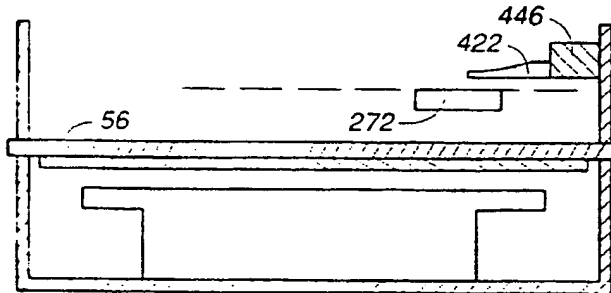
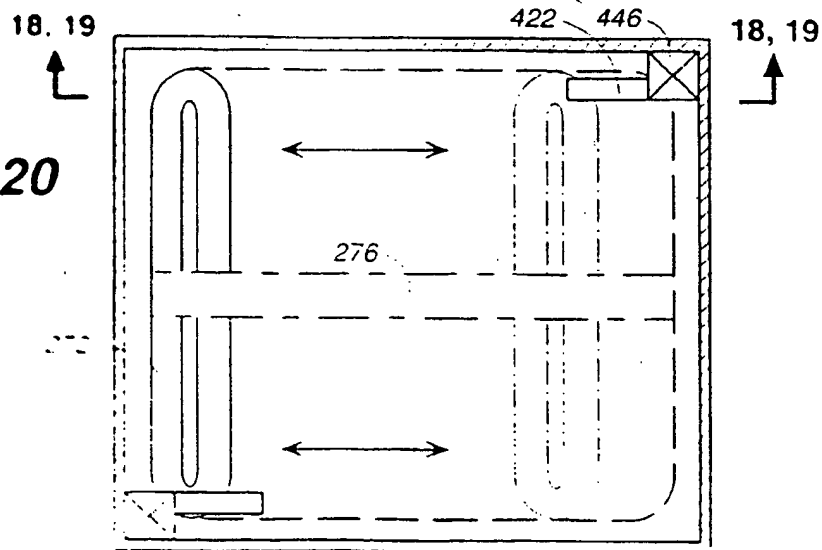
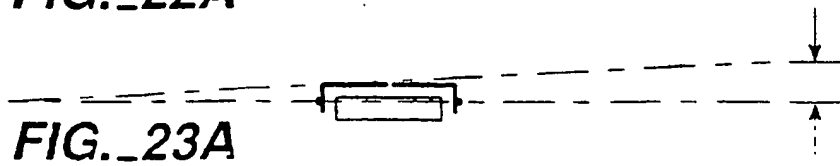
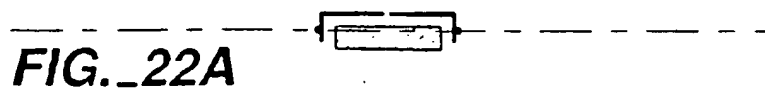
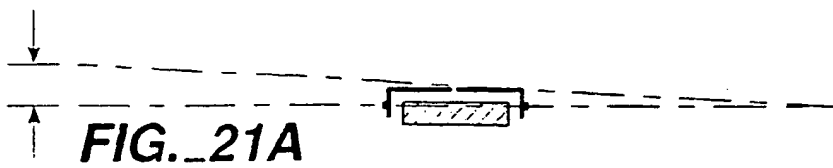
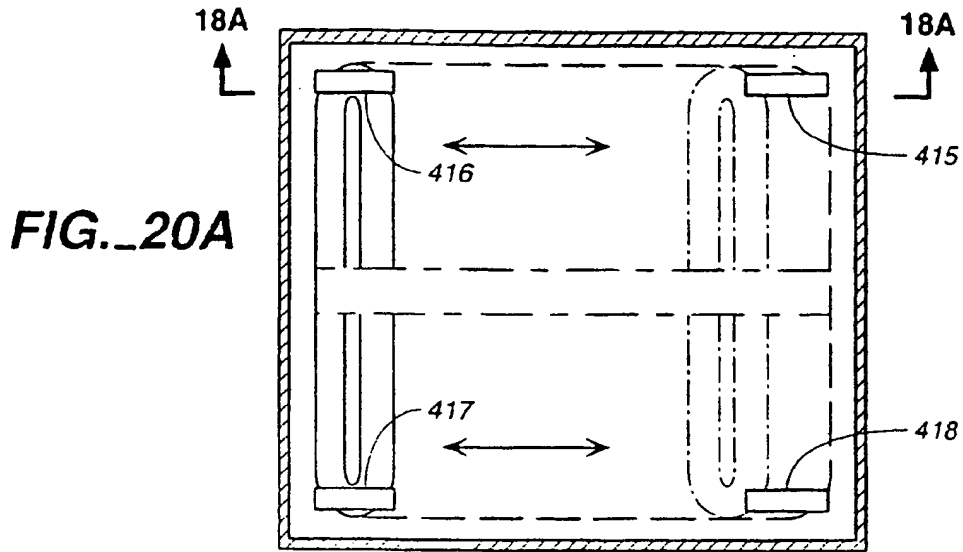
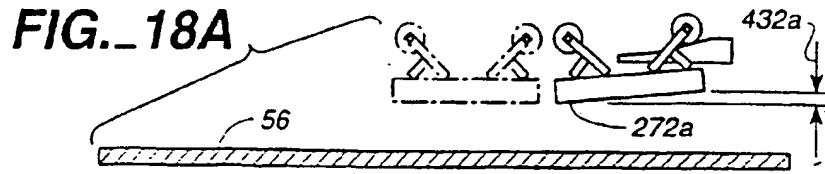
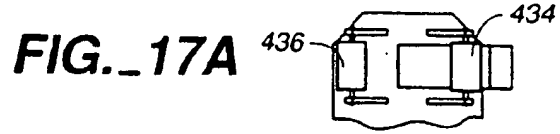
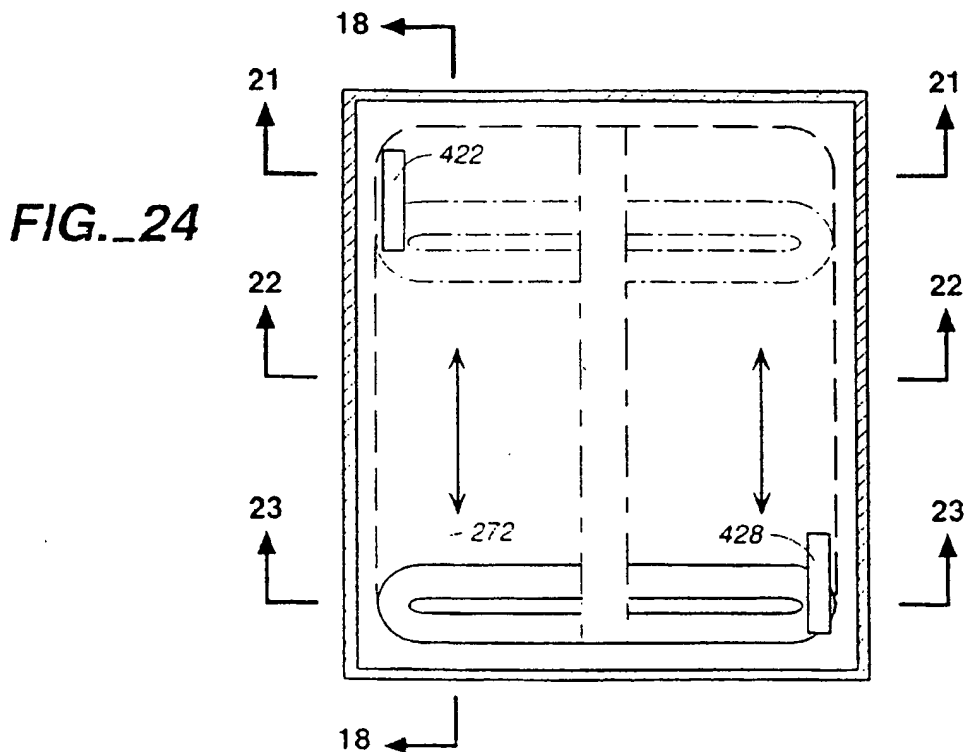
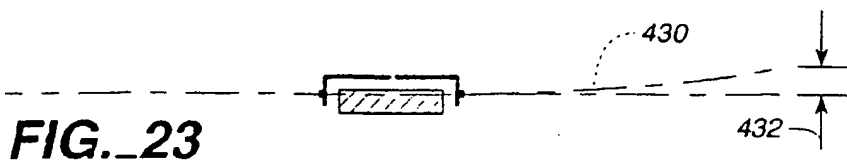
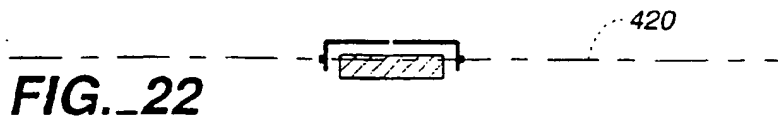
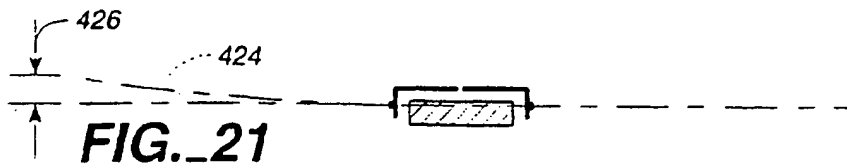


FIG.\_20









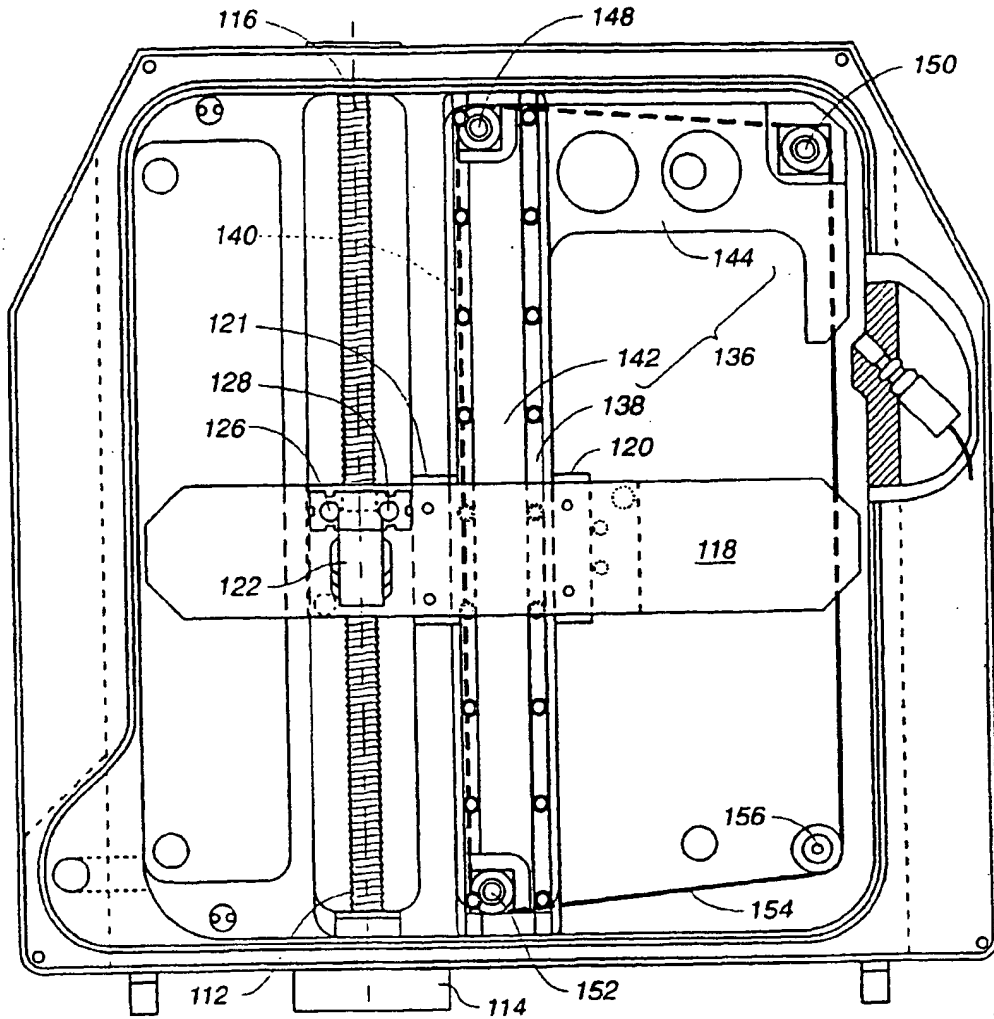


FIG. 25

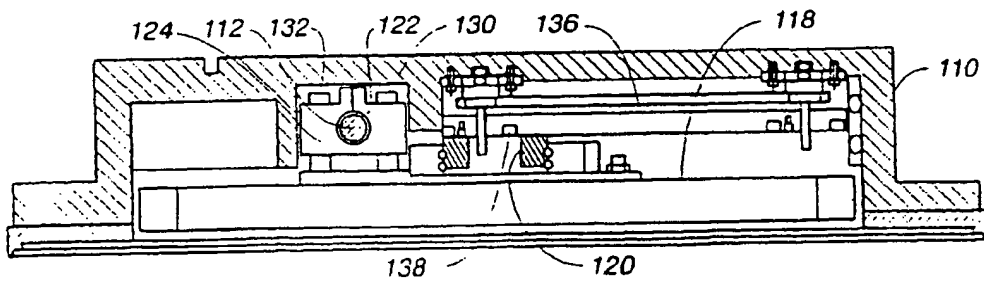
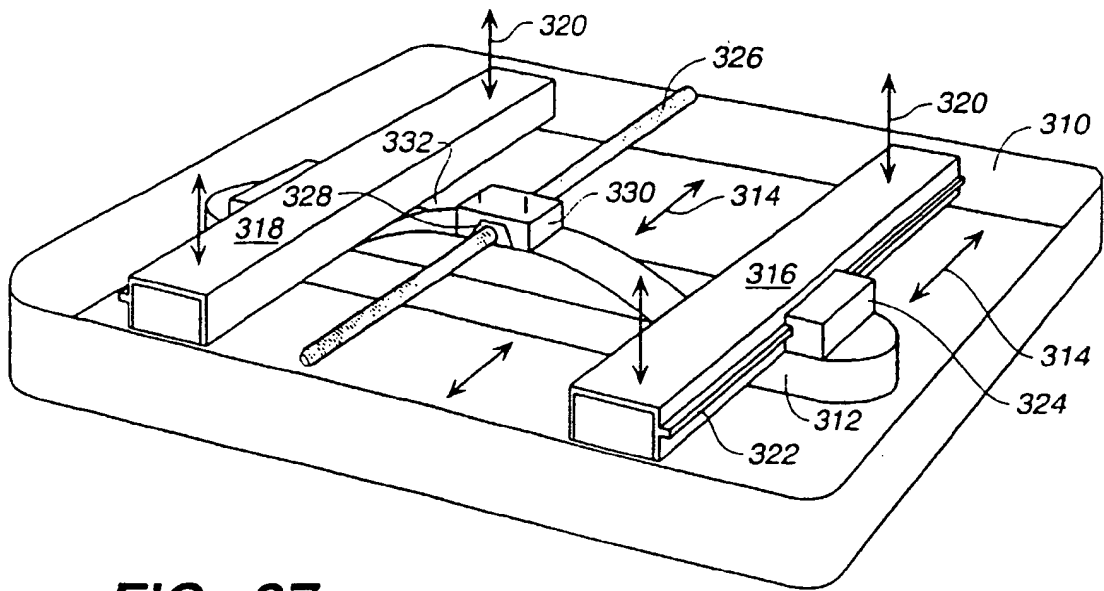
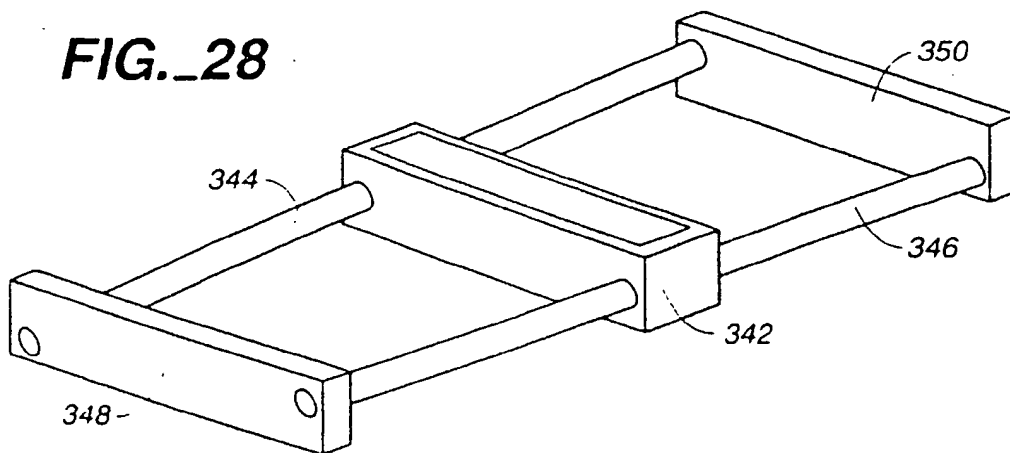


FIG. 26



**FIG. 27**



**FIG. 28**

FIG.\_29

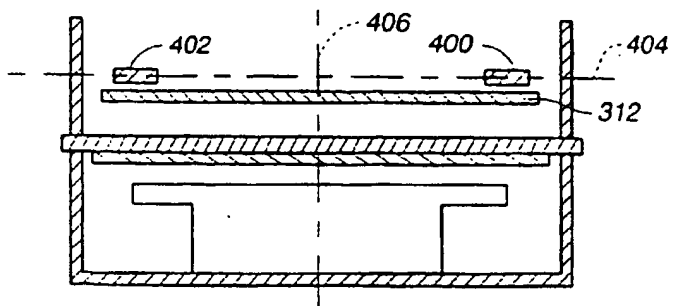


FIG.\_30

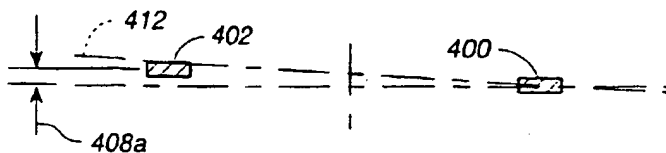


FIG.\_31

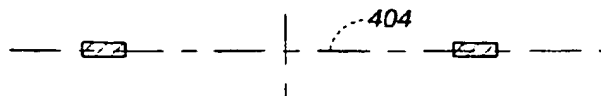


FIG.\_32

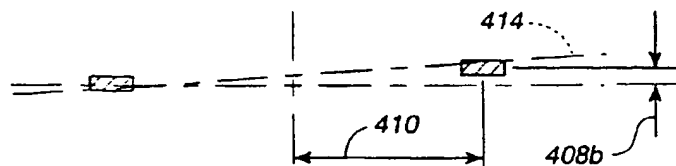
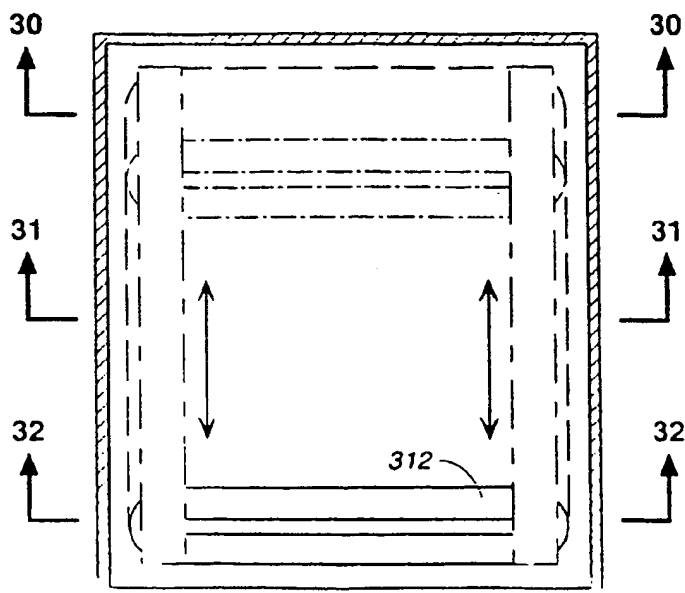


FIG.\_33



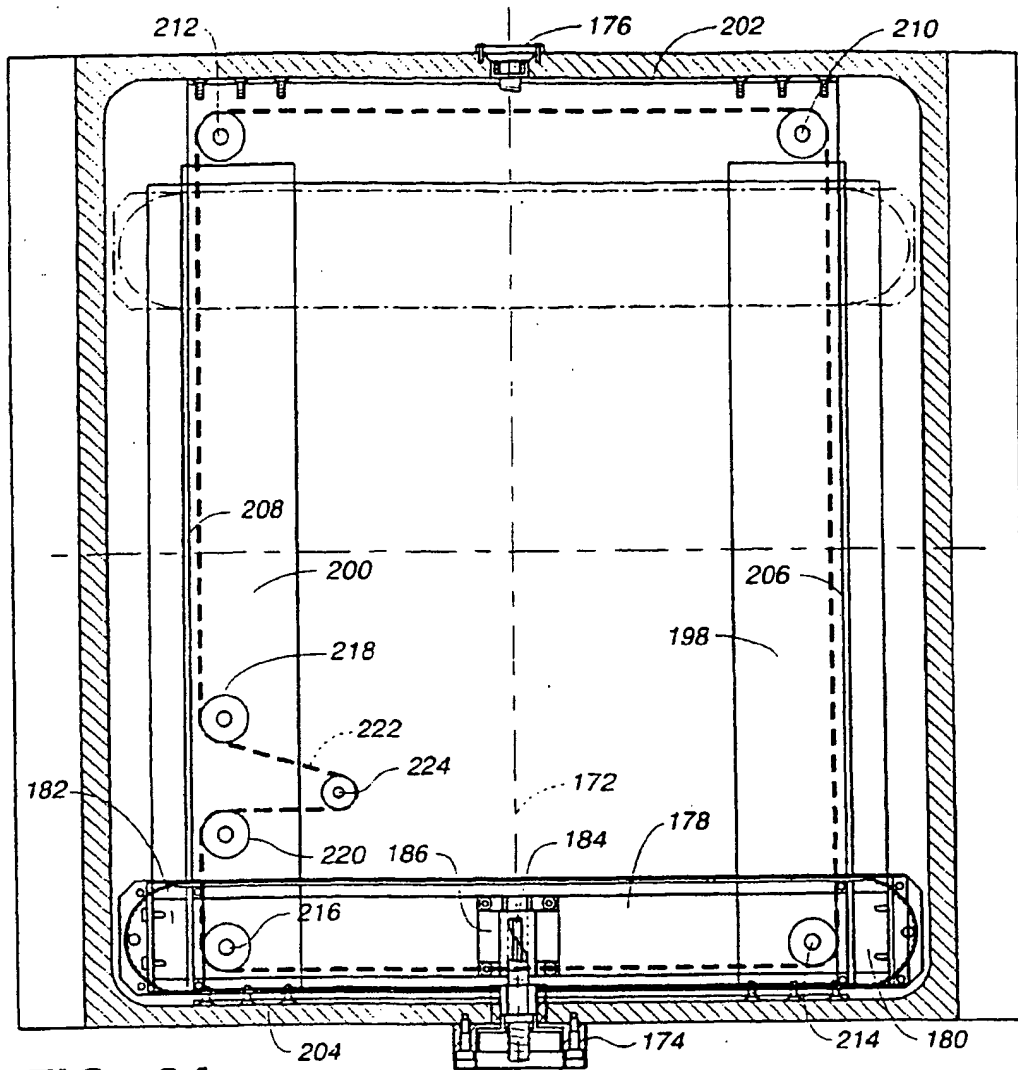


FIG. 34

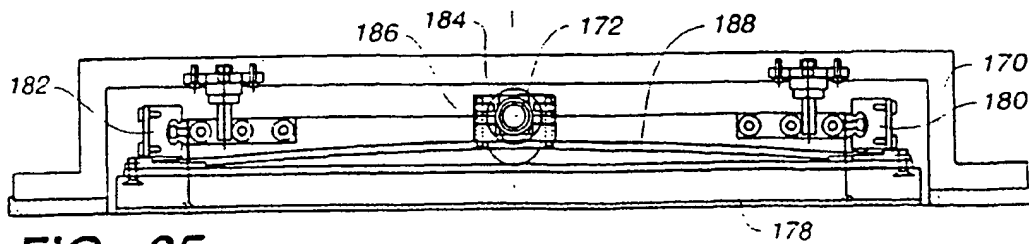
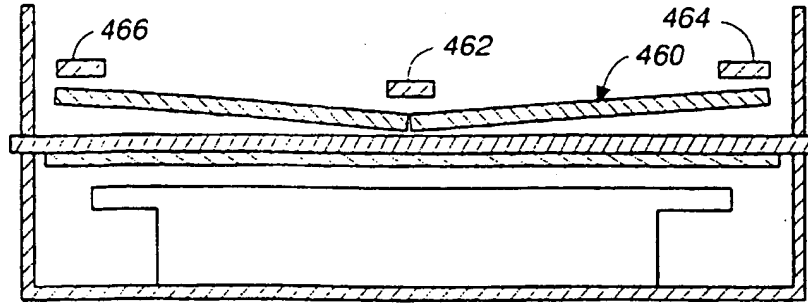
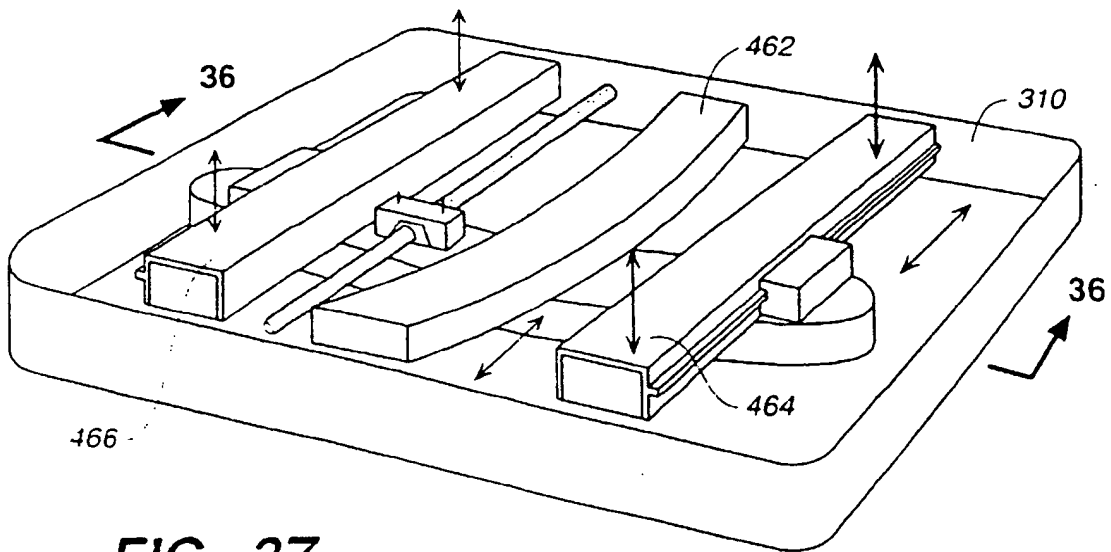


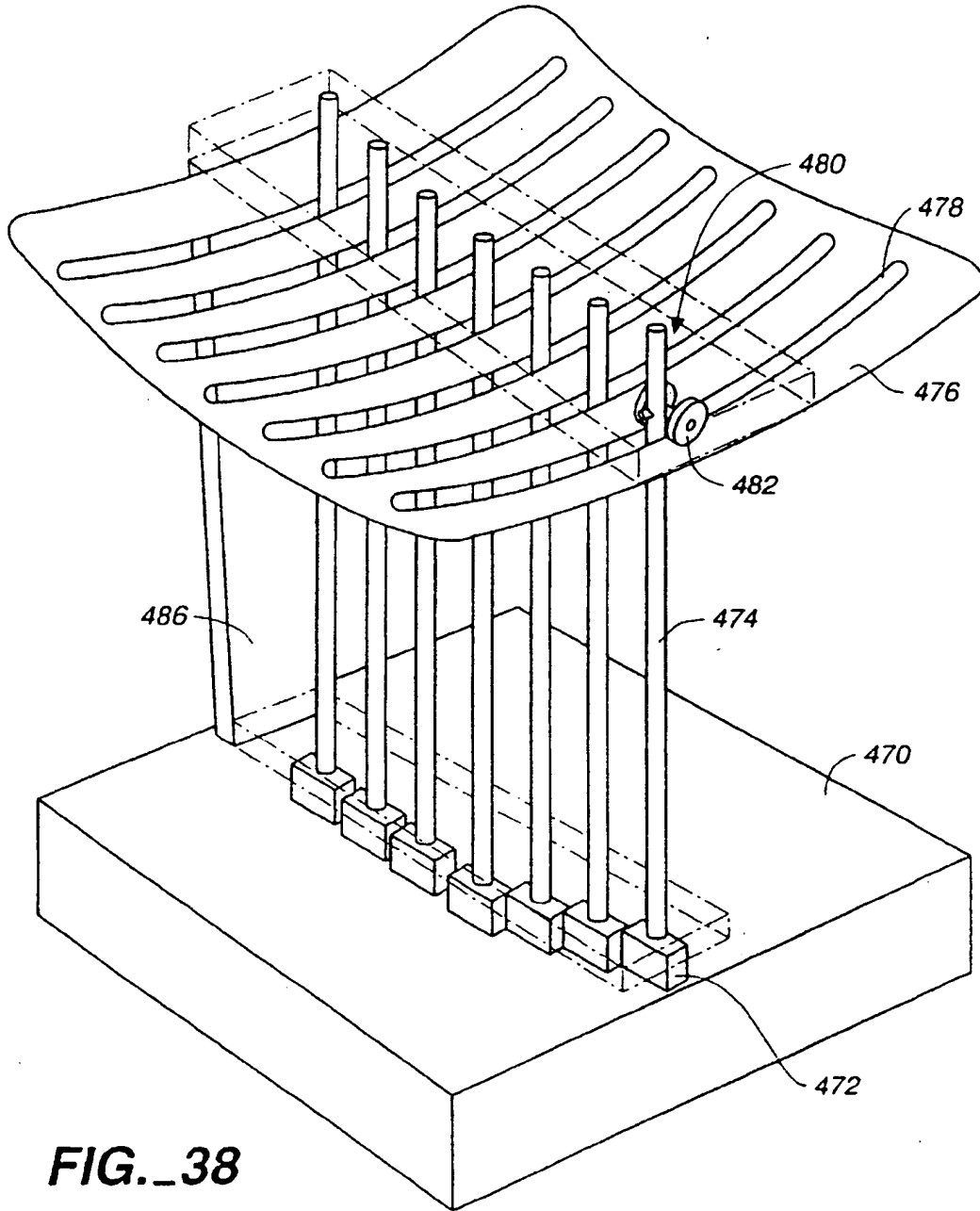
FIG. 35



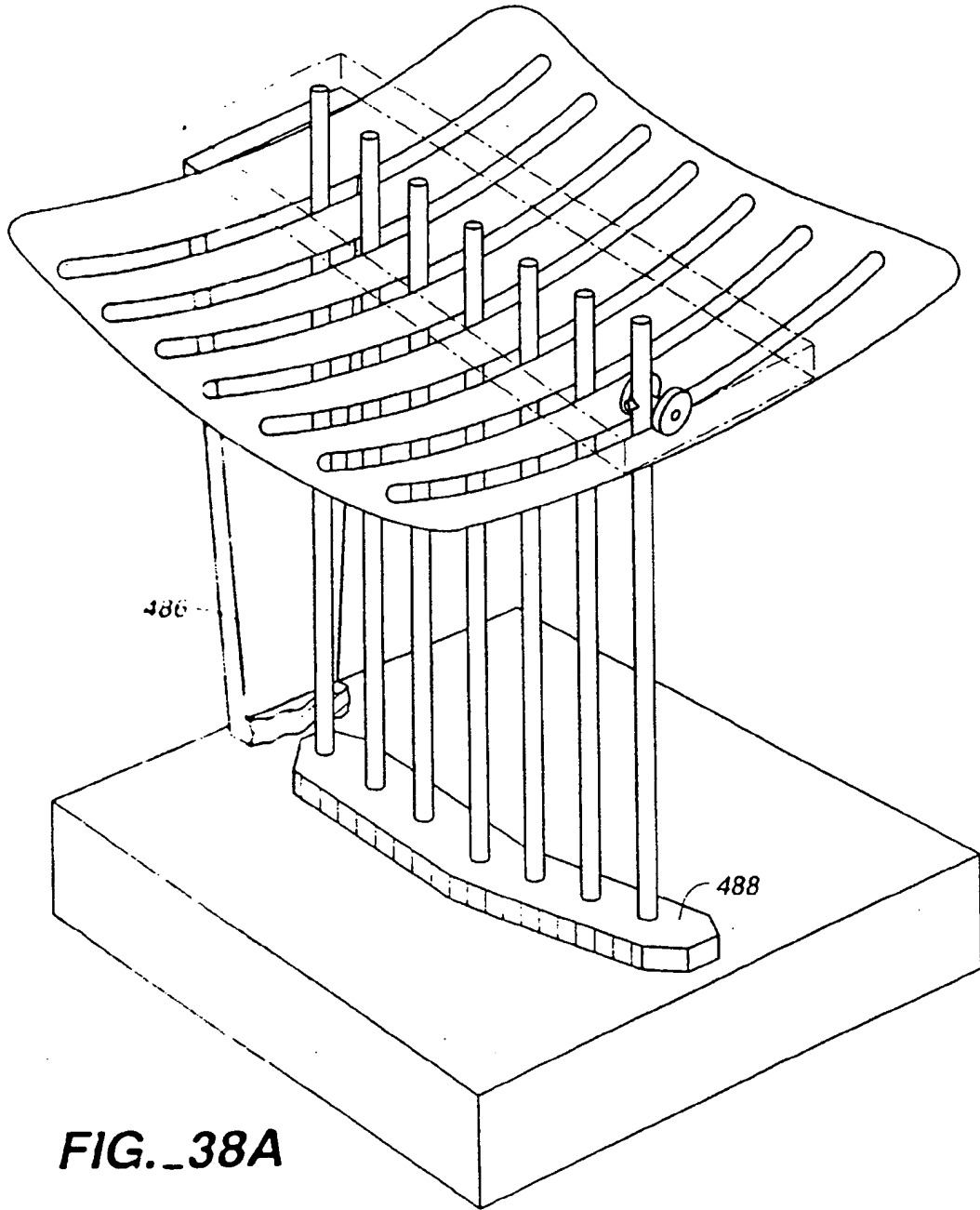
**FIG.\_36**

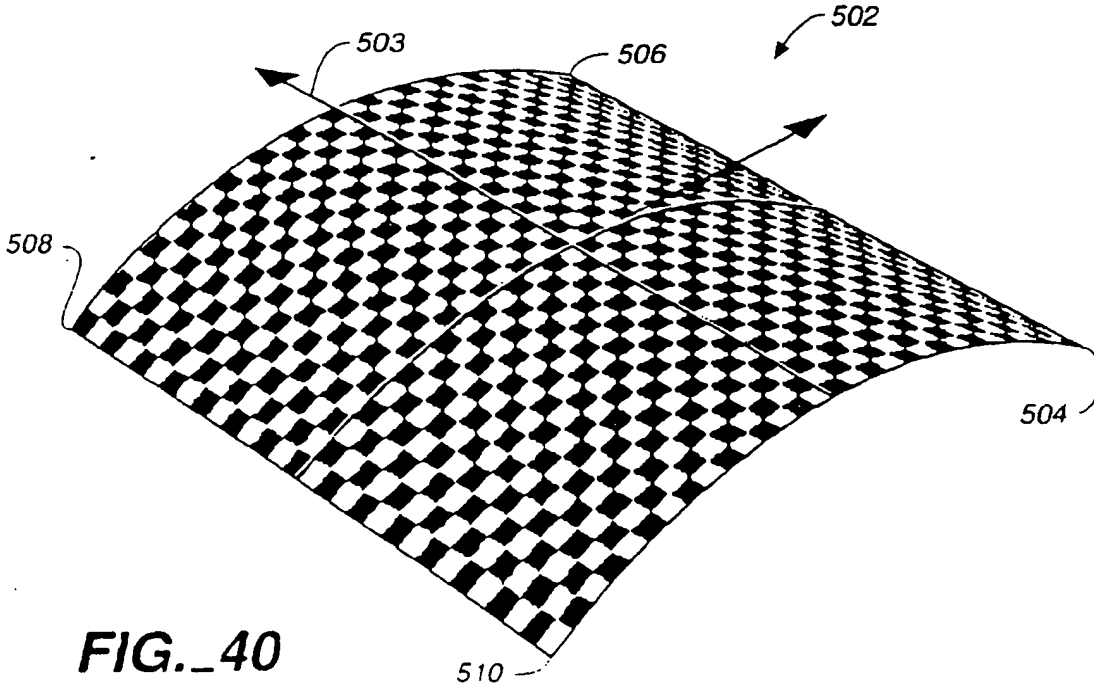
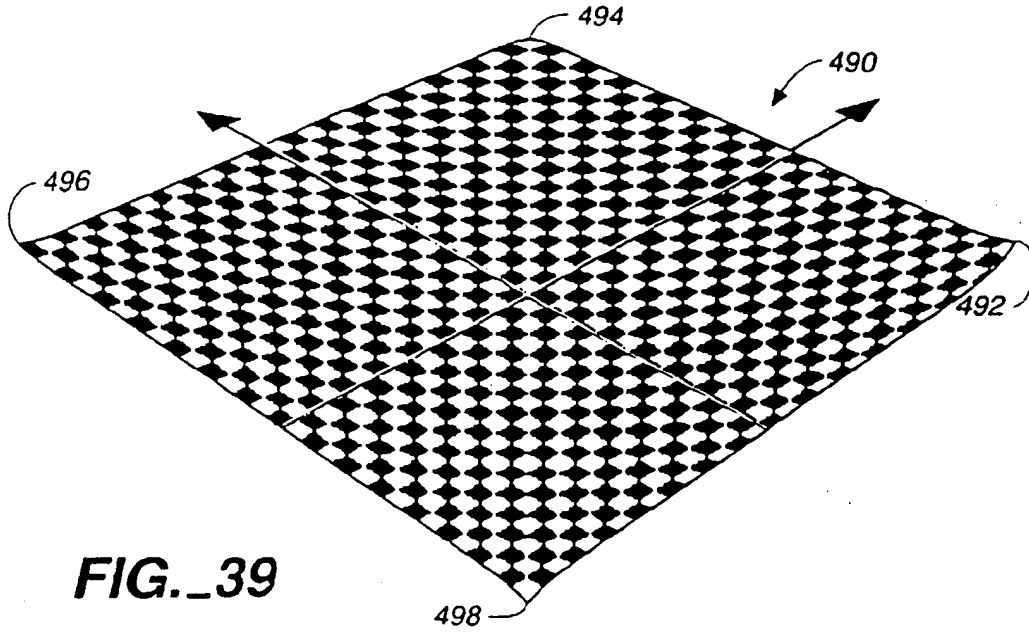


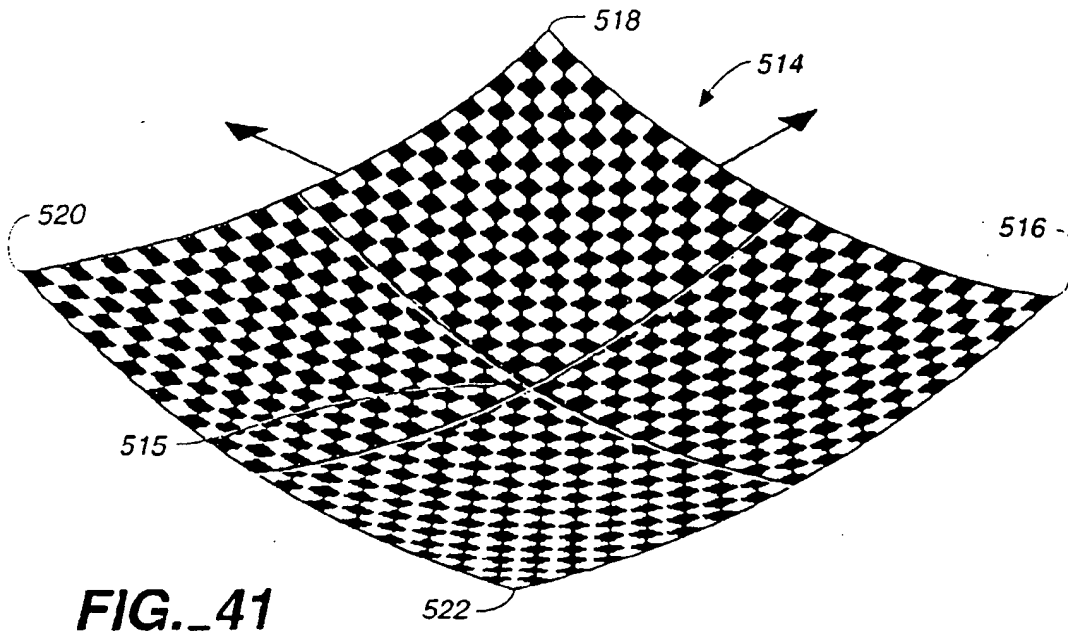
**FIG.\_37**



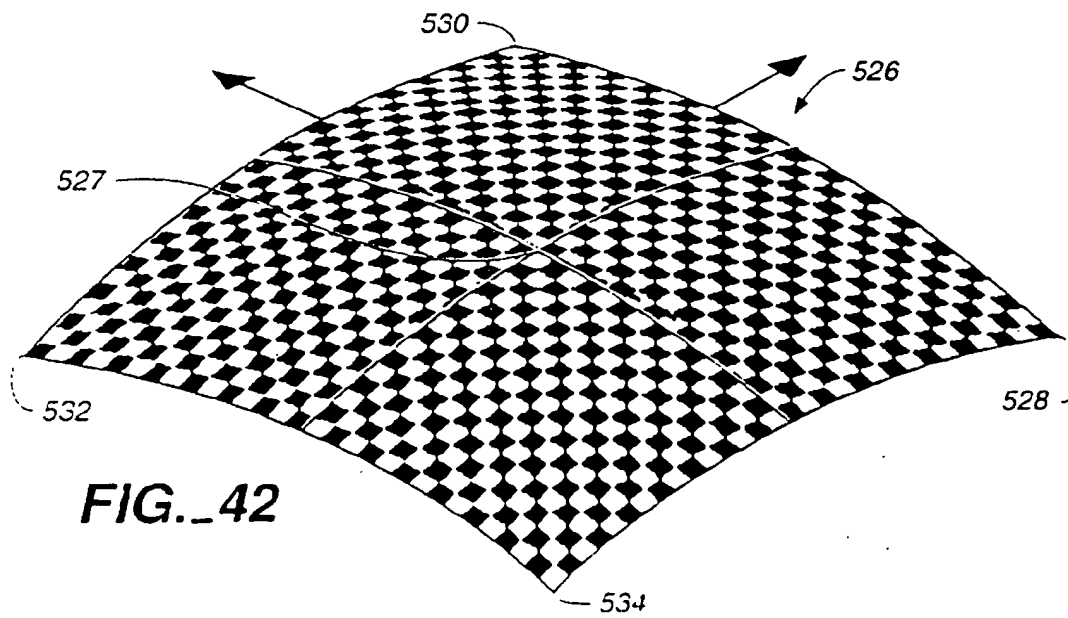




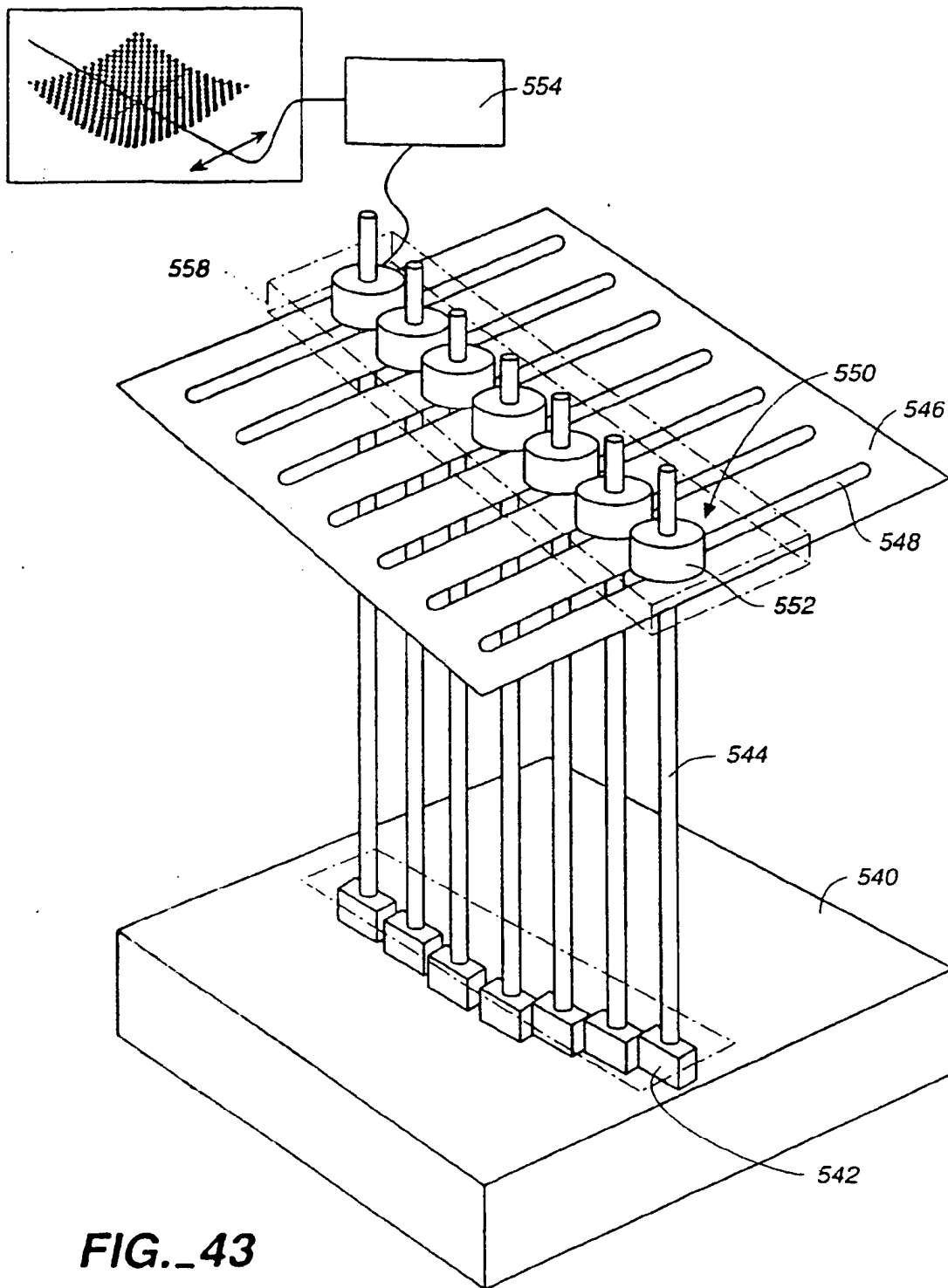




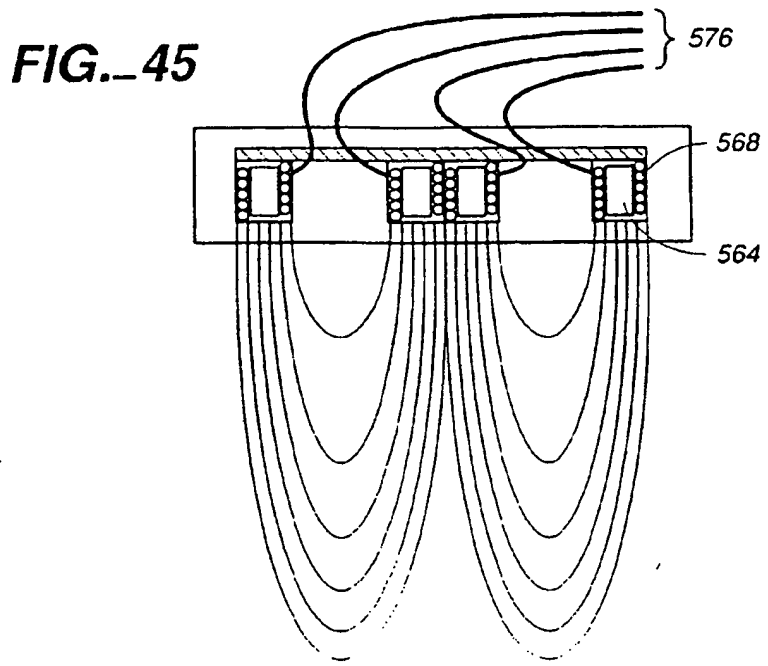
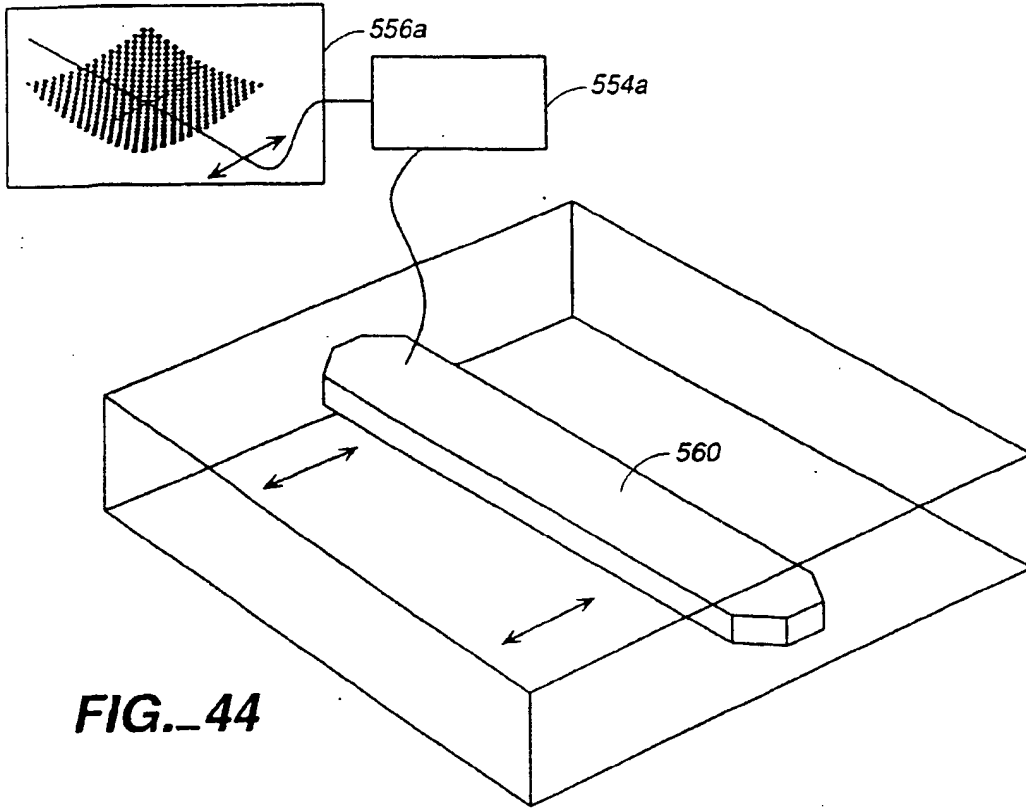
**FIG.\_41**

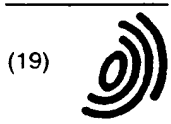


**FIG.\_42**



**FIG. 43**





Europäisches Patentamt  
European Patent Office  
Office européen des brevets



(11) EP 0 820 088 A3

(12) EUROPEAN PATENT APPLICATION

(88) Date of publication A3:  
25.10.2000 Bulletin 2000/43

(51) Int Cl.7: H01J 37/34

(43) Date of publication A2:  
21.01.1998 Bulletin 1998/04

(21) Application number: 97305316.8

(22) Date of filing: 16.07.1997

(84) Designated Contracting States:  
AT BE CH DE DK ES FI FR GB GR IE IT LI LU MC  
NL PT SE

- Black, Russell  
Longmont, Colorado 80501 (US)
- Hosokawa, Akihiro  
Cupertino, California 95014 (US)
- de Salvo, Allan M.  
Los Gatos, California 95030 (US)
- Hall, Victoria L.  
Menlo Park, California 94025 (US)

(30) Priority: 19.07.1996 US 684446

(71) Applicant: APPLIED KOMATSU TECHNOLOGY,  
INC.  
Shinjuku, Tokyo (JP)

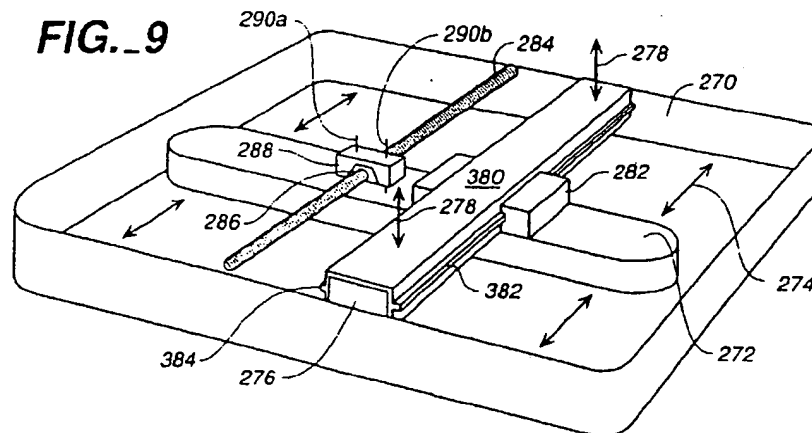
(74) Representative: Bayliss, Geoffrey Cyril et al  
BOULT WADE TENNANT,  
Verulam Gardens  
70 Gray's Inn Road  
London WC1X 8BT (GB)

(72) Inventors:  
• Halsey, Harlan L.  
Woodside, California 94062 (US)  
• Demaray, Richard E.  
Portola Valley, California 94028 (US)

(54) Non-planar magnet tracking device for magnetron sputtering apparatus

(57) The structure and method which improves the film thickness uniformity or thickness control when using magnetron sputtering by adjusting the distance between the magnetron (272) or a portion of the magnetron and the sputtering target to provide an improvement in the film thickness uniformity. Shimmed rails (382, 384) con-

toured rails, contoured surfaces (415, 418), cam plates (422), and cam plate control followers (442) are utilized to achieve an improvement in film thickness uniformity or thickness control due to anomalies in magnetic field as a magnetron assembly (272) moves back and forth when sputtering substrates (utilized primarily for rectangularly shaped substrates).



EP 0 820 088 A3



European Patent Office

EUROPEAN SEARCH REPORT

Application Number  
EP 97 30 5316

DOCUMENTS CONSIDERED TO BE RELEVANT			
Category	Citation of document with indication, where appropriate, of relevant passages	Relevant to claim	CLASSIFICATION OF THE APPLICATION (Int.Cl.6)
X	US 5 262 030 A (POTTER ROBERT I) 16 November 1993 (1993-11-16)	52	H01J37/34
A	* column 3, line 3 - line 52 * * column 7, line 28 - line 43 *	1,2,47	
Y	PATENT ABSTRACTS OF JAPAN vol. 017, no. 644 (C-1134), 30 November 1993 (1993-11-30)	47,51	
A	& JP 05 202471 A (FUJITSU LTD; OTHERS: 01), 10 August 1993 (1993-08-10) * abstract; figures 1,2 *	1,2,29, 39,45	
Y	US 4 600 492 A (OOSHIO HIROSUKE ET AL) 15 July 1986 (1986-07-15) * column 1, line 52 - column 2, line 25 * * figure 1 *	47,51	
A	US 5 079 481 A (MOSLEHI MEHRDAD M) 7 January 1992 (1992-01-07) * column 4, line 23 - line 37 * * column 8, line 33 - line 52 * * column 9, line 61 - column 10, line 9 * * column 19, line 6 - line 13 * * figures 4,5 *	1,2,29, 47,52	
A	PATENT ABSTRACTS OF JAPAN vol. 1995, no. 09, 31 October 1995 (1995-10-31) & JP 07 166346 A (ULVAC JAPAN LTD), 27 June 1995 (1995-06-27) * abstract; figures 5,7 *	1,2,29, 39,47, 51,52	TECHNICAL FIELDS SEARCHED (Int.Cl.8)  H01J
The present search report has been drawn up for all claims			
Place of search <b>THE HAGUE</b>		Date of completion of the search <b>30 August 2000</b>	Examiner <b>Aguilar, M.</b>
CATEGORY OF CITED DOCUMENTS X : particularly relevant if taken alone Y : particularly relevant if combined with another document of the same category A : technological background O : non-written disclosure P : intermediate document		T : theory or principle underlying the invention E : earlier patent document, but published on, or after the filing date D : document cited in the application L : document cited for other reasons s : member of the same patent family, corresponding document	

EP 0 820 088 A3 (1997.08.31)

ANNEX TO THE EUROPEAN SEARCH REPORT  
ON EUROPEAN PATENT APPLICATION NO.

EP 97 30 5316

This annex lists the patent family members relating to the patent documents cited in the above-mentioned European search report. The members are as contained in the European Patent Office EDP file on The European Patent Office is in no way liable for these particulars which are merely given for the purpose of information.

30-08-2000

Patent document cited in search report	Publication date	Patent family member(s)	Publication date
US 5262030 A	16-11-1993	NONE	
JP 05202471 A	10-08-1993	NONE	
US 4600492 A	15-07-1986	JP 61034177 A DE 3580412 D EP 0169532 A	18-02-1986 13-12-1990 29-01-1986
US 5079481 A	07-01-1992	NONE	
JP 07166346 A	27-06-1995	NONE	

EPO FORM P045P

For more details about this annex : see Official Journal of the European Patent Office. No. 12/82





Europäisches Patentamt  
European Patent Office  
Office européen des brevets



(11) EP 0 867 985 B1

(12) EUROPEAN PATENT SPECIFICATION

(45) Date of publication and mention  
of the grant of the patent:  
14.02.2001 Bulletin 2001/07

(51) Int Cl.7: H01S 3/06, C03C 3/17,  
C03C 4/00

(21) Application number: 97200930.2

(22) Date of filing: 27.03.1997

(54) Erbium-doped planar waveguide  
Erbiumdotierter planarer Wellenleiter  
Guide d'onde planaire dopée à l'erbium

(84) Designated Contracting States:  
AT BE CH DE DK ES FI FR GB IT LI NL SE

(56) References cited:  
US-A- 5 491 708

(43) Date of publication of application:  
30.09.1998 Bulletin 1998/40

(73) Proprietor: NEDERLANDSE ORGANISATIE VOOR  
TOEGEPAST-NATUURWETENSCHAPPELIJK  
ONDERZOEK TNO  
2628 VK Delft (NL)

- YINGCHAO YAN ET AL: "Er/sup 3+/ phosphate glass optical waveguide amplifiers at 1.5 mu m on silicon" FUNCTIONAL PHOTONIC AND FIBER DEVICES, SAN JOSE, CA, USA, 30 JAN.-1 FEB. 1996, vol. 2695, ISSN 0277-786X, PROCEEDINGS OF THE SPIE - THE INTERNATIONAL SOCIETY FOR OPTICAL ENGINEERING, 1996, SPIE-INT. SOC. OPT. ENG, USA, pages 144-148, XP002037998
- YINGCHAO YAN ET AL: "Luminescence quenching by OH groups in highly Er-doped phosphate glasses" JOURNAL OF NON-CRYSTALLINE SOLIDS, FEB. 1995, NETHERLANDS, vol. 181, no. 3, ISSN 0022-3093, pages 283-290, XP002037999

(72) Inventors:

- Yan, Yingchao  
5600 AN Eindhoven (NL)
- Faber, Anne Jans  
5600 AN Eindhoven (NL)

(74) Representative:  
Smulders, Theodorus A.H.J., Ir. et al  
Vereenigde  
Postbus 87930  
2508 DH Den Haag (NL)

Note: Within nine months from the publication of the mention of the grant of the European patent, any person may give notice to the European Patent Office of opposition to the European patent granted. Notice of opposition shall be filed in a written reasoned statement. It shall not be deemed to have been filed until the opposition fee has been paid. (Art. 99(1) European Patent Convention).

EP 0 867 985 B1

## Description

[0001] The present invention relates to a planar optical waveguide.

[0002] An optical waveguide is an important component in the field of telecommunication. A special type of optical waveguide is a planar optical waveguide, which can be manufactured as a part of an integrated circuit.

[0003] Nowadays, optical signals are very important for transmitting information. However, when an optical signal is transmitted through an optical fiber, attenuation will always occur to a certain extent, such that it is necessary to amplify the signal after a certain distance (typically in the order of about 50-100 km). Conventionally, for that purpose an electronic amplifier is used. At the amplifier station, the optical signal must then be converted into an electrical signal, which is amplified in an electronic amplifier, after which the amplified electrical signal is converted back into an optical signal. This involves not only the disadvantage that an amplifier station has a rather complicated structure with rather a large number of parts, among which optical/electrical converters and electrical/optical converters, but this also implies that the bandwidth and bit-rate of the overall system is limited by the electrical components.

[0004] Therefore, optical fibre amplifiers have recently been developed, i.e. amplifiers which amplify the optical signal directly and do not need a conversion into an electrical signal.

[0005] Similarly, integrated planar waveguide amplifiers are of necessity in order to realize all-optical telecommunication. For example, a planar waveguide amplifier can be integrated with a passive splitter as loss-compensating components. Due to their small sizes, planar optical waveguide amplifiers are expected to be of low cost, and more importantly, they offer the promise of integrating passive and active functions on the same substrate.

[0006] Materials for planar optical waveguides can be divided into different categories, among which:

(1) crystalline materials (LiNbO<sub>3</sub>, Al<sub>2</sub>O<sub>3</sub>, Y<sub>2</sub>O<sub>3</sub>, etc.)

(2) glassy materials, such as silicate-glass (based on SiO<sub>2</sub>), phosphate-glass (based on P<sub>2</sub>O<sub>5</sub>), etc.

[0007] The present invention relates to an optical waveguide material of this last-mentioned category, more specifically, phosphate-glass.

[0008] An optical waveguide material of this category is described in US patent 5.491.708. This publication describes a substrate having the following composition:

P <sub>2</sub> O <sub>5</sub>	50 - 70 mol%
Al <sub>2</sub> O <sub>3</sub>	4 - 13 mol%
Na <sub>2</sub> O	10 - 35 mol%
La <sub>2</sub> O <sub>3</sub>	0 - 6 mol%
R <sub>2</sub> O <sub>3</sub>	>0 - 6 mol%

wherein R is a lanthanide.

[0009] The lanthanide used in such composition can be considered as "active" component, as will be explained later. Generally speaking, in view of the fact that a planar waveguide device has a rather short length in the order of a few centimeters, the concentration of the lanthanide needs to be relatively high, and the pump power density needs to be relatively high for obtaining a sufficient optical amplification gain. Although it is technically possible to manufacture a waveguide material with a relatively high concentration of the lanthanide, the luminescence will be quenched by energy transfer processes due to ion-ion interactions. Furthermore, another cooperative upconversion quenching process dominates the amplification process of the devices when a high pump power is applied. These two luminescence quenching processes strongly influence the amplifier efficiency of planar waveguides amplifiers.

[0010] In the publication "Fabrication of Er Doped Glass Films as used in Planar Optical Waveguides" by Gates et al. in Mat. Res. Soc. Symp. Proc. Vol. 392, 1995, an Er-doped soda-lime silicate glass film on silicon is described. In a specific experiment, represented in figure 10 of said publication, a 4.5 cm long waveguide containing 5.5 wt% Er<sub>2</sub>O<sub>3</sub> was found to achieve about 4.2 dB/cm gain. However, in order to achieve result, this prior art waveguide needs a pump power in excess of 350 mW.

[0011] It is a particular purpose of the invention to provide an improved planar optical waveguide which can function as an optical amplifier.

[0012] It is a more particular purpose of the invention to provide an improved planar optical waveguide which can function as an optical amplifier for optical signals having wavelengths in the range of about 1.53 μm.

[0013] Especially, the present invention seeks to provide a material for an optical waveguide which has a good efficiency and which shows a relatively high amplification with relatively low pump power.

[0014] The invention is defined by claim 1. Various embodiments are defined by the dependent claims.

[0015] Hereinafter, the invention will be explained in more detail with reference to the drawing, in which:

Figure 1 schematically shows a cross-section of a planar optical waveguide device;  
 Figure 2 schematically shows an energy diagram for Er;  
 Figure 3 shows a schematic illustration of an amplification process;  
 and figure 4 schematically illustrates a co-operative upconversion process.

5

**[0016]** Figure 1 schematically shows a cross-section of a planar optical waveguide device, generally indicated at 10. The planar optical waveguide device 10 comprises a substrate 11, a buffer layer 12 arranged on a surface 9 of the substrate 11, an active guiding layer 13 arranged on the buffer layer 12, and a top cladding layer 14 arranged on the active guiding layer 13. The active guiding layer 13, which can for instance have a thickness of about 1  $\mu\text{m}$ , functions

10

as the actual guide for light beams in a direction parallel to said surface 9.  
**[0017]** The light beam can not escape from the active guiding layer 13 in the direction perpendicular to said surface 9, also indicated as the transverse direction, because the refractive indices of the buffer layer 12 and the top cladding layer 14 are lower than the refractive index of the active guiding layer 13. In an effective embodiment, the buffer layer 12 consists of  $\text{SiO}_2$ , which can be arranged on the substrate 11 by thermally oxidising the substrate 11, as is known per se; the buffer layer 12 can for instance have a thickness of about 6.5  $\mu\text{m}$ . Similarly, the top cladding layer 14 can consist of  $\text{SiO}_2$ , which can be arranged on the active guiding layer 13 by sputtering, as is known per se; the top cladding layer 14 can for instance have a thickness of about 0.5  $\mu\text{m}$ .

15

**[0018]** Further, within the active guiding layer 13 the light beam can only be transported in one direction parallel to said surface 9, indicated here as the guiding direction. The direction parallel to said surface 9 but perpendicular to said guiding direction will be indicated here as lateral direction. The light is confined in the lateral direction by a suitable shaping of either the active guiding layer 13 or the top cladding layer 14 such that a suitable refractive index profile is obtained in the lateral direction, as is known per se and not shown in figure 1.

20

**[0019]** The active guiding layer 13 has to satisfy several requirements in order for the guiding layer to be suitable in an optical waveguide, in an optical amplifier, or in a laser. The active guiding layer 13 should have a relatively high refractive index and a low optical attenuation, preferably <1 dB/cm at the applied wavelengths. Further, the active guiding layer 13 should have efficient optical amplification properties, for instance characterised by the luminescence efficiency of the active ions, like Er-ions. A very important feature of the active guiding layer 13 is the optical gain at a specific wavelength (region), expressed in dB/cm: it is a specific objective of the invention to obtain a relatively high gain with a relative low pump power. More specifically, it is an objective of the invention to provide an active guiding layer 13 which offers a gain of >4 dB/cm at a relatively low pump power (preferably less than 50 mW) for the wavelength of about 1.53  $\mu\text{m}$ .

25

30

**[0020]** According to an important feature of the invention, the active guiding layer 13 is manufactured as a phosphate glass having the following composition:

35

$\text{Al}_2\text{O}_3$	8 - 20 mol%	
$\text{Na}_2\text{O}$	5 - 18 mol%	
$\text{La}_2\text{O}_3$	6 - 35 mol%,	preferably 10 - 30 mol%
$\text{R}_2\text{O}_3$	>0 - 6 mol%,	preferably 0.5 - 1.5 mol%
$\text{P}_2\text{O}_5$	balance	

40

**[0021]** Herein, R represents Erbium (Er), Neodymium (Nd), or Ytterbium (Yb), or a combination of Er + Yb, depending on the wavelength of the optical waves which are to be guided and amplified. For applications where the optical wavelength is about 1.53  $\mu\text{m}$ , R represents Er.

45

**[0022]** For applying the active guiding layer 13 onto the buffer layer 12, several techniques can be used. A method which is particularly suitable, and which is used in the present invention, is RF sputtering. This technique is known per se, for which reason it will be discussed here only briefly. In a vacuum chamber, a target having a suitable composition with regard to the desired composition of the active guiding layer to be deposited, is arranged opposite a substrate. In the vacuum chamber, argon and oxygen are introduced, such that the pressure in the vacuum chamber is in the range of about 0.3 to 5 Pa. RF power is applied to the target. The target is hit by argon atoms, such that atoms and/or molecules of the target are emitted from the target and deposited on the substrate. This process is continued until the deposited layer has sufficient thickness.

50

**[0023]** It will be clear to a person skilled in the art, that other techniques can be used for applying the active guiding layer 13 onto the substrate, and that the invention is not restricted to the technique described above.

55

**[0024]** The present invention relates particularly to an optical waveguide device having an active guiding layer which comprises Erbium as active component. Therefore, in the following a description will be given of an optical amplification mechanism based on Erbium.

**[0025]** Erbium is a well-known rare-earth metal. The electronic structure of  $\text{Er}^{3+}$  is  $[\text{Xe}]4f^{11}$ , of which the partially

filled 4f shell is electronically shielded by the outlying filled 5s<sup>2</sup>5p<sup>6</sup> shells from the Xe configuration. Figure 2 shows schematically the energy diagram for the 4f electrons of a free Er<sup>3+</sup> ion (left hand side) and of an Er<sup>3+</sup> ion in a solid (right hand side). The various levels arise from spin-spin interactions and spin-orbit interactions. The energy levels are labeled as <sup>2S+1</sup>L<sub>J</sub>, wherein S represents the spin, L represents the orbit, and J represents the total angular momentum.

5 **[0026]** In the free Er<sup>3+</sup> ion, the 4f transitions are parity forbidden. In a solid such as a glass, however, the presence of surrounding atoms weakly perturbs the 4f states. The electric dipole transitions become allowed due to admixing of states of opposite parity from higher configuration into the 4f configuration. Due to the Stark-effect, the degenerate levels split into manifolds (see the right hand side of figure 2). In addition to this host-dependent forced electric dipole contribution, the <sup>4</sup>I<sub>13/2</sub> - <sup>4</sup>I<sub>15/2</sub> transition of Erbium at 1.53 μm has considerable magnetic dipole strength which is relatively insensitive to the host material. The spontaneous emission lifetime of the <sup>4</sup>I<sub>13/2</sub> - <sup>4</sup>I<sub>15/2</sub> transition of Erbium at 1.53 μm in a solid can be as long as about 10 ms.

**[0027]** Figure 3 shows a schematic illustration of the amplification process for the three-level system of Er<sup>3+</sup>, involving the states <sup>4</sup>I<sub>11/2</sub>, <sup>4</sup>I<sub>13/2</sub> and <sup>4</sup>I<sub>15/2</sub>.

15 **[0028]** By absorbing pump energy, Er<sup>3+</sup> ions can be excited to a state lying above the <sup>4</sup>I<sub>13/2</sub> state, such as the <sup>4</sup>I<sub>11/2</sub> state exemplified in figure 3. From this excited state, Er<sup>3+</sup> ions quickly decay to the metastable <sup>4</sup>I<sub>13/2</sub> manifold via non-radiative relaxation. Stimulated emission from the <sup>4</sup>I<sub>13/2</sub> state to the ground <sup>4</sup>I<sub>15/2</sub> state can cause amplification of light at 1.53 μm. The light amplification due to electronic transitions of Er<sup>3+</sup> works in a three-level lasing scheme. Light amplification in a three-level system can occur only when more than half of the population is excited to the upper lasing level (i.e. the <sup>4</sup>I<sub>13/2</sub> level for Er<sup>3+</sup>).

20 **[0029]** The principles of Er-doped optical amplifiers are the same for fiber waveguides and planar waveguides. However, in view of the required high Er doping levels in planar waveguide devices, planar waveguide devices are less efficient than fiber waveguide devices. The efficiency of the Er-doped waveguide amplifiers is influenced by two quenching processes, which are both related to the high Er doping levels, as will be discussed hereunder.

25 **[0030]** The first quenching process is concentration quenching. With increasing concentration of Er in the waveguide, the probability increases that an excited Er<sup>3+</sup> ion transfers its energy to a neighboring Er<sup>3+</sup> ion in the ground state via ion-ion interaction. Such process may be repeated until the energy is transferred to an Er<sup>3+</sup> ion correlated with a defect or an impurity ion, and the energy may be lost via non-radiative decay.

30 **[0031]** The second quenching process, which is believed to be the dominant process causing the inefficiency of prior Er-doped waveguide devices, is a co-operative upconversion process, which is also due to ion-ion interactions. This process, which plays a role especially when the population inversion is high, is illustrated in figure 4. With increasing concentration of Er in the waveguide, the probability increases that an excited Er<sup>3+</sup> ion transfers its energy to a neighboring excited Er<sup>3+</sup> ion. Then, the first Er<sup>3+</sup> ion may decay non-radiatively to the ground <sup>4</sup>I<sub>15/2</sub> state, while the second Er<sup>3+</sup> ion is excited to a higher lying state <sup>4</sup>I<sub>9/2</sub>. This second Er<sup>3+</sup> ion then has a high probability to decay to the <sup>4</sup>I<sub>13/2</sub> state via non-radiative relaxation. The net result of this upconversion process is that the population in the upper lasing state of <sup>4</sup>I<sub>13/2</sub> is strongly reduced and the efficiency of light amplification at 1.53 μm by stimulated emission is strongly decreased.

**[0032]** The upconversion quenching process is a property which is related to the host material, i.e. the waveguide material into which the Er ions are embedded, since it is caused by the ion-ion interactions of Er<sup>3+</sup> ions in the host.

**[0033]** Therefore, an important feature of the present invention is the composition of the host material.

#### EXAMPLE

45 **[0034]** An optical waveguide device was manufactured in accordance with figure 1. As basis material, a standard silicon substrate was used, in the shape of a circular disk having a diameter of about 7,5 cm. By way of a standard thermal oxidation process, a buffer layer 12 having a thickness of about 6.5 μm was applied on the substrate.

50 **[0035]** A suitable glass target was prepared by mixing and melting Al<sub>2</sub>O<sub>3</sub>, Na<sub>2</sub>O, La<sub>2</sub>O<sub>3</sub>, P<sub>2</sub>O<sub>5</sub>, and Er<sub>2</sub>O<sub>3</sub>, in a suitable proportion. This target was positioned opposite said oxidised substrate in a standard sputtering chamber, and by way of a standard low-pressure magnetron RF sputtering process as briefly discussed above, an active guiding layer 13 having a composition (determined by X-ray photoelectron spectroscopy) as specified hereunder in Table 1 was applied on the buffer layer 12.

TABLE 1

P <sub>2</sub> O <sub>5</sub>	42-45 mol%
Al <sub>2</sub> O <sub>3</sub>	16-18 mol%
Na <sub>2</sub> O	8.5-11 mol%
La <sub>2</sub> O <sub>3</sub>	27-28 mol%
Er <sub>2</sub> O <sub>3</sub>	0.9-1.2 mol%

[0036] The process was continued for about 4 hours. The thickness of the active guiding layer 13 was measured, and appeared to be about 1  $\mu\text{m}$ .

[0037] By way of a standard sputtering process, a top cladding layer 14 of  $\text{SiO}_2$  was applied over said structure, the top cladding layer 14 having a thickness of about 0.5  $\mu\text{m}$ .

[0038] Then, by way of standard photolithography and etching processes, most part of the layer 14 was removed to form stratified line strips of 4  $\mu\text{m}$  wide, providing lateral confinement of the guided light in the active layer 13.

[0039] Finally, the active guiding layer 13 was made into a structure having a length of 10 mm by cleaving the silicon substrate.

[0040] This planar waveguide device was tested for its optical properties. It appeared that the active guiding layer 13 had a refractive index of about 1.56 at 633 nm; with such a high refractive index, a high light confinement can be obtained in the waveguide, which leads to a high density of the pump power. For a wavelength of 1.53  $\mu\text{m}$ , an optical confinement of about 70 % was obtained.

[0041] The optical amplification for light having a wavelength of 1.53  $\mu\text{m}$  was measured, wherein pump light having a wavelength of 980 nm was applied to the planar waveguide device. For this experimental planar waveguide device having a length of 10 mm, a net optical gain of 4.1 dB was measured with a pump power of about 65 mW. This pump power is already very low. It is noted, however, that in this experiment the coupling efficiency of the pump light into the active guiding layer 13 appeared to be about 30%, so that the amount of pump light which actually entered the active guiding layer 13 was about 20 mW. In this experiment, no effort was taken to improve the coupling efficiency, but it will be evident for a skilled person that improvement of the coupling efficiency to about 80% or more is possible. Therefore, it is reasonable to expect that an optical waveguide device with a length of 4 cm, having the structure as described, wherein the active guiding layer 13 has the composition as described, will yield an optical gain of 15 dB or more with a launched pump power of 40 mW or less.

[0042] From the experimental data, it was calculated that the upconversion coefficient (as defined and used in the publication "Cooperative upconversion in Erbium implanted sodalime silicate glass optical waveguides" by E. Snoeks et al in J.Opt.Soc.Am.B., 12, 1468 (1995)) of the active guiding layer 13 had a value of about  $2.6 \cdot 10^{-18} \text{ cm}^3/\text{s}$ . This value is one of the lowest values reported to date.

[0043] Further, it was found that in the active guiding layer, the luminescence lifetime of Er was about 7.2 ms.

[0044] It will be clear to a person skilled in the art that the invention is not limited to the above-described examples but that variations and modifications will be possible without going beyond the scope of the invention as described in the claims. For instance, although in the examples the active guiding layer 13 is manufactured by way of an RF sputtering process, as an alternative other processes may be used for manufacturing the active guiding layer.

[0045] Further, in practice, it may happen that the material of the active guiding layer 13 comprises impurities such as for instance Mg, Ca, Cr, Ba, Zn, Pb, Li, K. Although small amounts of such impurities can be permitted, according to the invention it is preferred that the amounts of such impurities are as low as possible, preferably zero, such that the active guiding layer 13 is composed substantially only of  $\text{P}_2\text{O}_5$ ,  $\text{Al}_2\text{O}_3$ ,  $\text{Na}_2\text{O}$ ,  $\text{La}_2\text{O}_3$  and  $\text{Er}_2\text{O}_3$ .

[0046] Further, according to an important feature of the invention, the optical device may be provided with at least one element for achieving optical feedback, for instance a mirror or other reflective element, such that the device can function as a laser.

## Claims

1. A planar optical waveguide device, comprising:

- a substrate (11);
- an active guiding layer (13) arranged on the substrate (11);
- a bottom layer (12) arranged between the active guiding layer (13) and the substrate (11);
- a top cladding layer (14) arranged over the active guiding layer (13);

wherein the active guiding layer (13) has the following composition:

$\text{Al}_2\text{O}_3$	8 - 20 mol%	
$\text{Na}_2\text{O}$	5 - 18 mol%	
$\text{La}_2\text{O}_3$	6 - 35 mol%,	preferably 10 - 30 mol%
$\text{Er}_2\text{O}_3$	>0 - 6 mol%,	preferably 0.5 - 1.5 mol%
$\text{P}_2\text{O}_5$	balance	

wherein, R represents Erbium (Er), Neodymium (Nd), or Ytterbium (Yb), or a combination of Er + Yb.

2. A planar optical waveguide device according to claim 1, wherein the active guiding layer (13) has the following composition:

5

P <sub>2</sub> O <sub>5</sub>	42-45 mol%
Al <sub>2</sub> O <sub>3</sub>	16-18 mol%
Na <sub>2</sub> O	8.5-11 mol%
La <sub>2</sub> O <sub>3</sub>	27-28 mol%
Er <sub>2</sub> O <sub>3</sub>	0.9-1.2 mol%

10

3. A planar optical waveguide device according to any of claims 1-2, wherein the optical waveguide device is an optical amplifier.

15

4. A planar optical waveguide device according to any of claims 1-3, wherein the substrate (11) is made of Si, wherein the bottom layer (12) is made of SiO<sub>2</sub>, and wherein the top cladding layer (14) is made of SiO<sub>2</sub>.

20

5. A planar optical waveguide device according to any of the claims 1-4, wherein the amplification gain for wavelengths of light which results by transition of Er<sup>3+</sup> ions from the <sup>4</sup>I<sub>13/2</sub> state to the <sup>4</sup>I<sub>15/2</sub> state is at least 4.1 dB/cm with a pump power of no more than 65 mW, and wherein the active guiding layer (13) has a refractive index of 1.54 - 1.65 at 632.8 nm.

25

6. An optical device according to any of claims 1, 2, 4, further comprising at least one optical feedback element, e. g. a coating mirror, such that the device can function as a laser.

**Patentansprüche**

30

1. Planares Lichtwellenleiterbauteil, umfassend:

- ein Substrat (11);
- eine aktive Leitschicht (13), die auf dem Substrat (11) angeordnet ist;
- eine untere Schicht (12), die zwischen der aktiven Leitschicht (13) und dem Substrat (11) angeordnet ist;
- eine obere Mantelschicht (14), die über der aktiven Leitschicht (13) angeordnet ist;

35

wobei die aktive Leitschicht (13) die folgende Zusammensetzung hat:

40

Al <sub>2</sub> O <sub>3</sub>	8 - 20 Mol-%
Na <sub>2</sub> O	5 - 18 Mol-%
La <sub>2</sub> O <sub>3</sub>	6 - 35 Mol-%, vorzugsweise 10 - 30 Mol-%
R <sub>2</sub> O <sub>3</sub>	>0- 6 Mol-%, vorzugsweise 0,5 - 1,5 Mol-%
P <sub>2</sub> O <sub>5</sub>	Rest,

45

wobei R Erbium (Er), Neodym (Nd) oder Ytterbium (Yb) oder eine Kombination von Er + Yb bedeutet.

2. Planares Lichtwellenleiterbauteil gemäß Anspruch 1, wobei die aktive Leitschicht (13) die folgende Zusammensetzung hat:

50

P <sub>2</sub> O <sub>5</sub>	42 - 45 Mol-%
Al <sub>2</sub> O <sub>3</sub>	16 - 18 Mol-%
Na <sub>2</sub> O	8,5 - 11 Mol-%
La <sub>2</sub> O <sub>3</sub>	27 - 28 Mol-%
Er <sub>2</sub> O <sub>3</sub>	0,9 - 1,2 Mol-%.

55

3. Planares Lichtwellenleiterbauteil gemäß einem der Ansprüche 1-2, wobei das Lichtwellenleiterbauteil ein optischer

Verstärker ist.

4. Planares Lichtwellenleiterbauteil gemäß einem der Ansprüche 1-3, wobei das Substrat (11) aus Si besteht, wobei die untere Schicht (12) aus SiO<sub>2</sub> besteht und wobei die obere Mantelschicht (14) aus SiO<sub>2</sub> besteht.
5. Planares Lichtwellenleiterbauteil gemäß einem der Ansprüche 1-4, wobei die Verstärkung für Lichtwellenlängen, die sich durch Übergang von Er<sup>3+</sup>-Ionen vom <sup>4</sup>I<sub>13/2</sub>-Zustand zum <sup>4</sup>I<sub>15/2</sub>-Zustand ergibt, wenigstens 4,1 dB/cm mit einer Pumpleistung von nicht mehr als 65 mW beträgt und wobei die aktive Leitschicht (13) einen Brechungsindex von 1,54-1,65 bei 632,8 nm hat.
6. Optisches Bauteil gemäß einem der Ansprüche 1, 2, 4, das weiterhin wenigstens ein optisches Rückkopplungselement, z.B. einen Beschichtungsspiegel, umfasst, so dass das Bauteil als Laser fungieren kann.

**Revendications**

1. Dispositif à guide d'onde optique plan, comprenant : un substrat (11),

une couche active de guidage (13) disposée sur le substrat (11),  
 une couche inférieure (12) placée entre la couche active de guidage (13) et le substrat (11), et  
 une couche supérieure de revêtement (14) disposée sur la couche active de guidage (13),

dans lequel la couche active de guidage (13) a la composition suivante :

Al <sub>2</sub> O <sub>3</sub>	8 à 20 mol %
Na <sub>2</sub> O	5 à 18 mol %
La <sub>2</sub> O <sub>3</sub>	6 à 35 mol %, de préférence 10 à 30 mol %
R <sub>2</sub> O <sub>3</sub>	> 0 à 6 mol %, de préférence 0,5 à 1,5 mol %
P <sub>2</sub> O <sub>5</sub>	le reste

dans laquelle R représente l'erbium (Er), le néodyme (Nd) ou le l'ytterbium (Yb) ou une combinaison Er + Yb.

2. Dispositif à guide d'onde optique plan selon la revendication 1, dans lequel la couche active de guidage (13) a la composition suivante :

P <sub>2</sub> O <sub>5</sub>	42 à 45 mol %
Al <sub>2</sub> O <sub>3</sub>	16 à 18 mol %
Na <sub>2</sub> O	8,5 à 11 mol %
La <sub>2</sub> O <sub>3</sub>	27 à 28 mol %
Er <sub>2</sub> O <sub>3</sub>	0,9 à 1,2 mol %

3. Dispositif à guide d'onde optique plan selon l'une des revendications 1 et 2, dans lequel le dispositif à guide d'onde d'onde optique est un amplificateur optique.
4. Dispositif à guide d'onde optique plan selon les revendications 1 à 3, dans lequel le substrat (11) est formé de Si, la couche inférieure (12) est formée de SiO<sub>2</sub>, et la couche supérieure de revêtement (14) est formée de SiO<sub>2</sub>.
5. Dispositif à guide d'onde optique plan selon l'une quelconque des revendications 1 à 4, dans lequel le gain d'amplification pour les longueurs d'onde de la lumière qui proviennent de la transition des ions Er<sup>3+</sup> de l'état <sup>4</sup>I<sub>13/2</sub> à l'état <sup>4</sup>I<sub>15/2</sub> est d'au moins 4,1 dB/cm avec une puissance de pompage ne dépassant pas 65 mW, et la couche active de guidage (13) a un indice de réfraction compris entre 1,54 et 1,65 à 632,8 nm.
6. Dispositif optique selon l'une quelconque des revendications 1, 2 et 4, comprenant en outre au moins un élément optique de réaction, tel qu'un miroir possédant un revêtement, si bien que le dispositif peut jouer le rôle d'un laser.

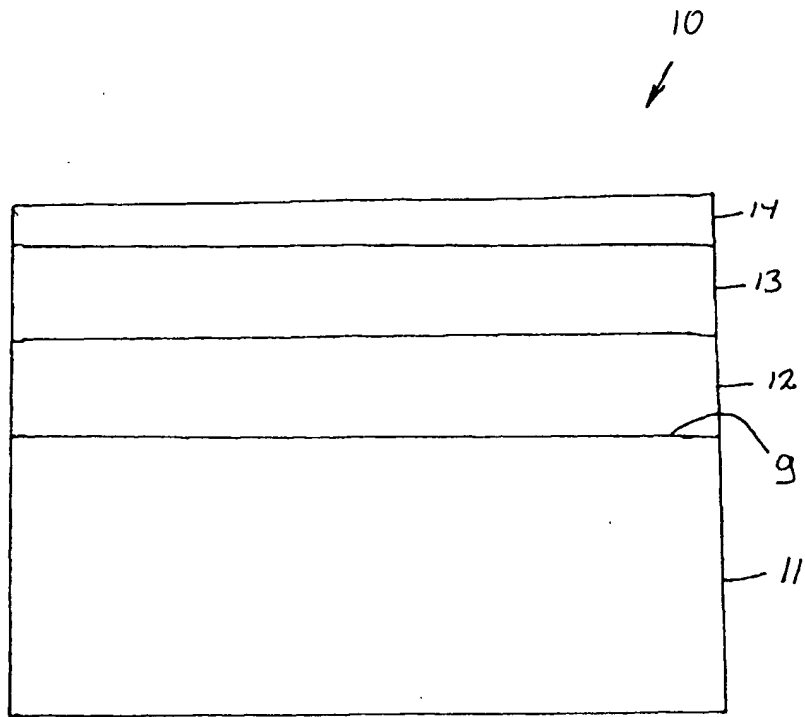


FIG. 1



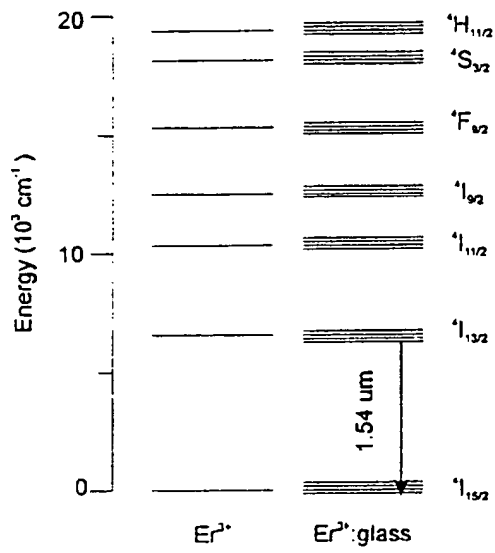


FIG. 2

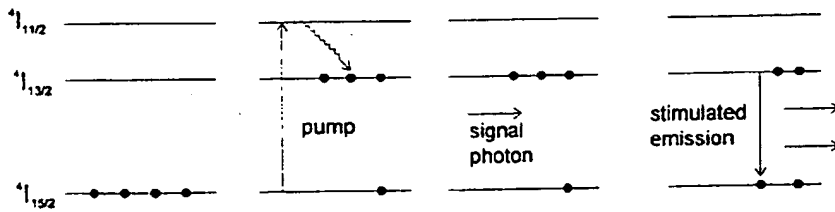


FIG. 3

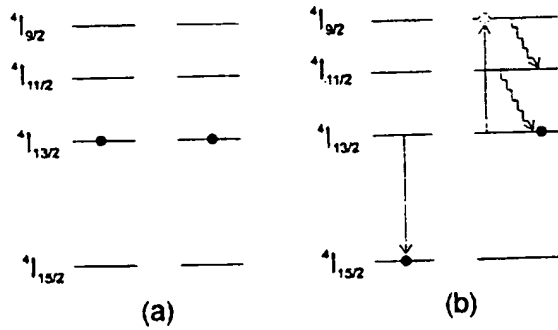


FIG. 4

# EUROPEAN PATENT OFFICE

## Patent Abstracts of Japan

PUBLICATION NUMBER : 06010127  
PUBLICATION DATE : 18-01-94

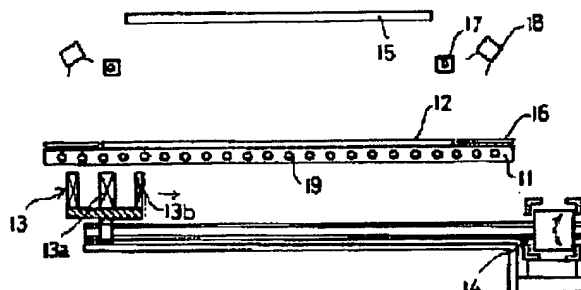
APPLICATION DATE : 28-06-92  
APPLICATION NUMBER : 04193348

APPLICANT : ULVAC JAPAN LTD;

INVENTOR : TSUKAGOSHI OSAMU;

INT.CL. : C23C 14/35

TITLE : MAGNETRON SPUTTERING DEVICE



**ABSTRACT :** **PURPOSE** To provide the magnetron sputtering device which improves the efficiency of using a target and can prevent the generation of impurities by sputtering, etc.

**CONSTITUTION:** A moving means 14 is mounted to a magnet device 13 installed on the rear surface side of a backing plate 11 mounted with the target 12 on its front surface and this magnet device 13 is moved along the rear surface of the backing plate 11. In addition, the magnet device 13 is so moved that high-density plasma is protruded at both ends between one end and the other end of the target 12 by this movement.

COPYRIGHT (C)1994,JPO&Japio

(51)Int.Cl.<sup>5</sup>  
C 2 3 C 14/35

識別記号 庁内整理番号  
9046-4K

F I

技術表示箇所

審査請求 未請求 請求項の数 8 (全 9 頁)

(21)出願番号 特願平4-193348

(22)出願日 平成4年(1992)6月28日

(71)出願人 000231464

日本真空技術株式会社  
神奈川県茅ヶ崎市萩園2500番地

(72)発明者 内田 岱二郎

神奈川県茅ヶ崎市萩園2500番地日本真空技  
術株式会社内

(72)発明者 塚越 修

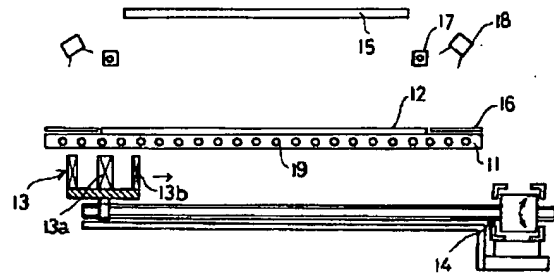
神奈川県茅ヶ崎市萩園2500番地日本真空技  
術株式会社内

(54)【発明の名称】 マグネトロンスパッタ装置

(57)【要約】 (修正有)

【目的】 この発明の目的は、ターゲットの使用効率を向上させると共に、スパッタによる不純物の発生等を防止することの可能なマグネトロンスパッタ装置を提供することにある。

【構成】 この発明のマグネトロンスパッタ装置は、ターゲット12を表面に取り付けたバックングプレート11の裏面側に配設した磁石装置13に移動手段14を取り付け、その磁石装置13をバックングプレート11の裏面に沿って移動させ、かつ、その移動により、高密度のプラズマがターゲット12の一端部と他端部との間で各端部においてはみ出すようになるまで、磁石装置13を動かすことを特徴とするものである。



【特許請求の範囲】

【請求項1】 バッキングプレートの表面にターゲットを取り付け、バッキングプレートの裏面側に磁石装置を配設し、この磁石装置によってターゲット表面近傍の空間に湾曲した磁場を形成し、この湾曲した磁場によりターゲット表面近傍の空間に高密度のプラズマを発生し、この高密度のプラズマ中のイオンをターゲットに加速衝突させてターゲットをスパッタして、ターゲットに対向して配置された基板に薄膜を形成するマグネトロンスパッタ装置において、上記磁石装置に移動手段を取り付け、この移動手段によって上記磁石装置を上記バッキングプレートの裏面に沿って移動させ、かつ、その移動により上記高密度のプラズマが上記ターゲットの一端部と他端部との間で各端部においてはみ出すようになるまで、上記磁石装置を動かすことを特徴とするマグネトロンスパッタ装置。

【請求項2】 上記ターゲットの端部の廻りを取り囲むように、この端部と隙間をもってアースシールドを配置し、上記隙間にプラズマを流入させないことを特徴とする請求項1記載のマグネトロンスパッタ装置。

【請求項3】 上記磁石装置は、中央部磁石と、この中央部磁石の廻りにこれと間隔をおいて配置された周縁部磁石とを備えることを特徴とする請求項1又は2記載のマグネトロンスパッタ装置。

【請求項4】 上記磁石装置は少なくとも2つの棒状磁石を間隔をおいて平行に配置したものであって、各棒状磁石は上記ターゲットの端部と同方向に伸びていることを特徴とする請求項1又は2記載のマグネトロンスパッタ装置。

【請求項5】 上記ターゲットの端部に近紫外又は紫外線を照射して光電子を発生させ、その光電子をプラズマに供給する電子供給手段を備えていることを特徴とする請求項3又は4記載のマグネトロンスパッタ装置。

【請求項6】 上記ターゲットの端部に熱電子を供給する電子供給手段を備えていることを特徴とする請求項3又は4記載のマグネトロンスパッタ装置。

【請求項7】 上記ターゲットに高周波電力供給手段を備えたことを特徴とする請求項3又は4記載のマグネトロンスパッタ装置。

【請求項8】 上記ターゲットの端部にマイクロ波電力供給手段を備え、その部分に局部的に電子サイクロン共鳴(SCR)放電を起こさせる特徴とする請求項3又は4記載のマグネトロンスパッタ装置。

【発明の詳細な説明】

【0001】

【産業上の利用分野】 この発明は、ターゲットを表面に取り付けたバッキングプレートの裏面側に配設した磁石装置を移動させるマグネトロンスパッタ装置に関するものである。

【0002】

【従来の技術】 従来、ターゲットを表面に取り付けたバッキングプレートの裏面側に磁石装置を配設し、この磁石装置によりターゲットの表面近傍の空間にマグネロン放電を起こさせて、高密度のプラズマを発生させ、ターゲット材料のITO(インジウム・スズ・酸化物)等をスパッタして、基板にITO等の薄膜を形成するマグネトロンスパッタ装置が広く工業的に用いられてきた。

【0003】 従来のマグネトロンスパッタ装置の一例が図18、図19、図20に示されている。これらの図において、バッキングプレート1の表面にはターゲット2が取り付けられ、また、バッキングプレート1の裏面側には磁石装置3が移動できないように配設されている。磁石装置3は中央部磁石3aの廻りにこれと間隔をおいて配置された周縁部磁石3bとが備えられている。ターゲット2の上方にはこれと対向するように基板4が配置され、また、ターゲット2の端部の廻りには接地されたアースシールド5がターゲット2を取り囲むように端部と隙間をもって配置され、隙間にプラズマが流入しないようにしている。ターゲット2と基板4との間の空間にはリング状のアノード電極6が配置され、このアノード電極6は接地電位となっている。一方、バッキングプレート1には負電圧が印加されている。

【0004】 なお、図中、7は磁石ケース、8は冷却パイプである。

【0005】 従来のマグネトロンスパッタ装置では、図21に示されるようにターゲット2の表面近傍の空間において磁石装置3による湾曲したポロイダル磁場が形成されると共に、ターゲット2とアノード電極6との間の電位差による電場が形成され、これらの磁場と電場とによって直交電磁場が生じるようになる。ターゲット2の表面から宇宙線、自然放射能による二次電子またはエキソ電子が放射されたとすると、これらの電子はターゲット2の表面近傍の空間の直交電磁場により、これに垂直な方向で電場ベクトル(E)と磁場ベクトル(B)とのベクトル積(E×B)の向きに数回のサイクロイドを描きながら運動する。この間にキャリア・ガス(普通アルゴンが用いられる)分子と衝突してエネルギーの一部を失った電子は、電子に対するポテンシャルの高いターゲット2には戻れず直交電磁場中をトロコイド軌道を描きながら、レース・トラック状のポロイダル磁場の中をドリフトしてゆく。1cmドリフトして行く間のトロコイド軌道の延べ軌道長は数十cmから数百cmに達する。此の間にキャリア・ガスと衝突してイオン化し、電子とイオンを発生させる(α作用)機会を生じ、生じた電子はやはりトロコイド軌道を描きながらドリフトし、生じたイオンはターゲット2へと加速されてこれと衝突し、ターゲット2の材料のスパッタと二次電子の放出を行い(γ(ガンマ)作用)、放出された二次電子は一次電子と同様のことをおこなう。この様にして、プラズ

マが成長し、ターゲット2の表面近傍の空間にレース・トラック状のプラズマが発生する。ターゲット2、プラズマ間のシース電圧によってキャリア・ガスのイオンがターゲット2へと加速され、ターゲット2の材料をスパッタして基板4に薄膜を形成させる。上記のトロコイド軌道を描きながらベクトル積 ( $E \times B$ ) の方向にドリフトをしてゆく電子は図21に示されるように磁力線が上方に凸に湾曲しているため、シースまたはシースの遷移領域における電場と直交しない場合には、電子が電場ベクトル ( $E$ ) からうける力  $-e \times$  ベクトル ( $E$ ) の磁力線方向の力の成分により湾曲している磁力線の頂点の方向へと曲がってゆき、この部分がもっとも電子の濃度が高くなる。従ってイオンも此処に集まりプラズマはこの部分が最も粒子密度が高くなり、従ってこの部分に対応するターゲット2の部分が最もスパッタされ、部分的にエロードされる。

#### 【0006】

【発明が解決しようとする課題】従来のマグネトロンスパッタ装置は、上記のようにターゲット2を表面に取り付けたバックリングプレート1の裏面側に移動できない磁石装置3を配設しているため、ターゲット2の表面近傍の空間において形成される湾曲したポロイダル磁場により高密度のプラズマが形成されるようになる。そのため、ターゲット2の上では、形成された高密度のプラズマ直下の部分が最もスパッタされ、部分的にエロードされるようになる。逆にいえば、ターゲット2の周縁部ではスパッタされる機会に恵まれず、ターゲット2の使用効率が低下する原因となっていた。

【0007】従来のマグネトロンスパッタ装置の他の一例が図22、図23に示されている。これらの図において、バックリングプレート1の表面にはターゲット2が取り付けられ、また、バックリングプレート1の裏面にはターゲット2の表面にレーストラック状のポロイダル磁場を発生させる磁石装置3と、この磁石装置3をバックリングプレート1の裏面に沿って移動させる移動装置9が取り付けられている。但し、磁石装置3はターゲット2の表面に発生したプラズマがターゲット2外にはみ出さない範囲で移動し、また、ターゲット2の端部に特別に電子を発生させるような外部電子発生装置は設けていない。

【0008】この従来のマグネトロンスパッタ装置の他の一例では、プラズマは磁石装置3の移動と共に、ターゲット2の表面に沿って移動し、磁石装置の固定型で見られるような部分的にエロードされる領域がターゲット2にそって動いてゆくので、磁石装置の固定型より広い範囲のターゲット2がエロードされる。しかし、ターゲット2の端に特別に電子を発生させるような外部電子発生装置は設けていないので、プラズマがターゲット2の外にはみ出すような位置まで移動させると、レーストラック状のポロイダル磁場の中をトロコイド軌跡を描きながら

運動して、 $\alpha$ 作用によって、イオン・電子対を発生させていた電子の道筋が、プラズマの一部がターゲット2の外にはみ出した途端に中断されて、プラズマが消えてしまうので、磁石装置3を、ターゲット2をはみ出さない所までしか移動させることができない。したがって、ターゲット2の周辺部がエロードされずに残り、又、磁石装置3の移動にも制限がつけられるので、ターゲット2の使用効率は十分にあげられない。又、エロードされずに残った部分にスパッタされたターゲット材料が付着して、はがれ、好ましくないゴミ(パーティキュレート)を発生し、又、異常放電を発生させる原因となる。

【0009】この発明の目的は、従来の上記問題等を解決して、ターゲットの使用効率を向上させると共に、スパッタによる不純物の発生等を防止することの可能なマグネトロンスパッタ装置を提供することにある。

#### 【0010】

【課題を解決するための手段】上記目的を達成するために、この発明は、バックリングプレートの表面にターゲットを取り付け、バックリングプレートの裏面側に磁石装置を配設し、この磁石装置によってターゲット表面近傍の空間に湾曲した磁場を形成し、この湾曲した磁場によりターゲット表面近傍の空間に高密度のプラズマを発生し、この高密度のプラズマ中のイオンをターゲットに加速衝突させてターゲットをスパッタして、ターゲットに対向して配置された基板に薄膜を形成するマグネトロンスパッタ装置において、上記磁石装置に移動手段を取り付け、この移動手段によって上記磁石装置を上記バックリングプレートの裏面に沿って移動させ、かつ、その移動により上記高密度のプラズマが上記ターゲットの一端部と他端部との間で各端部においてはみ出すようになるまで、上記磁石装置を動かすことを特徴とするものである。

【0011】なお、この発明においては、上記ターゲットの端部の廻りを取り囲むように、この端部と隙間においてアースシールドを配置する。そして、上記隙間にプラズマを流入させないようにすることが必要である。また、上記磁石装置は、中央部磁石と、この中央部磁石の廻りにこれと間隔をおいて配置された周縁部磁石とを備えたものを使用することが必要である。更に、上記磁石装置は少なくとも2つの棒状磁石を間隔をおいて平行に配置したものであって、各棒状磁石は上記ターゲットの端部と同方向に伸びているものを使用することも必要である。更にその上、上記ターゲットの端部に光電子又は熱電子を供給する電子供給手段、もしくは、上記ターゲットに接続する高周波電力供給手段、又は、ターゲットの端部に局所的にマイクロ波電力を供給する手段を備え、この部分に電子サイクロン共鳴(SCR)放電を起こさせることも必要である。

#### 【0012】

【作用】この発明においては、磁石装置に移動手段を取り付け、この移動手段によって磁石装置をバックングプレートの裏面に沿って移動させ、その移動により高密度のプラズマをターゲットの一端部と他端部との間で各端部においてはみ出すようになるまで動かしているの、ターゲットの周縁部においてもスパッタされ、ターゲットが全体にわたって均等にスパッタされるようになる。

【0013】なお、ターゲットの端部の廻りを取り囲むように、端部と隙間をもってアースシールドを配置し、隙間にプラズマを流入させないようにしたときには、ターゲット以外の物質をスパッタすることがなくなるので、スパッタによる不純物の発生を防止させることができるようになる。また、ターゲットの端部に光電子又は熱電子を供給する電子供給手段、もしくは、ターゲットに接続する高周波電力供給手段、又は、マイクロ波電力供給手段を備えているときには、プラズマの出発点で光電子、熱電子の補給、RF電圧による強勢、又はマイクロ波によるECR放電が起こり、上記の手段を設けない従来の他の一例では、レーストラック状のプラズマの一部がターゲットの外側にはみ出すような位置まで磁石装置が移動してきたとき、ターゲットの外側にはみ出した部分のプラズマが消えるばかりでなく、磁石装置の他の一部がターゲットの下にあるような部分までプラズマが非常に弱くなるが、本発明のように上記の手段を設けることにより、このような位置まで磁石装置が動いてきたときもターゲットの外側にはみ出したプラズマの部分は消えるが、磁石装置の他の一部がターゲットの下にあるような部分では、磁石装置がターゲットの下にある部分のはじまりの場所からプラズマが強く立ち上がり、プラズマを出発点から強くし、ターゲットの外にはみ出した一部は消えても、残りの部分では磁石装置がターゲットの外にはみ出さない場合と全く同一の強度となり、スパッタの不均一性を生じさせなくなる。

【0014】更に、2本の棒状磁石の場合（棒状磁石といってもこの言葉から連想されるように長手方向の両端にN極とS極とがあるものとは全くことなり、上方にS極、下方にN極をもつ立方体磁石辺を横一列に図9、図10のように並べたものと、上方にN極、下方にS極をもつ立方体磁石辺を横一列に並べたものとを、図9、図10のように向い合せたものであるが、以後、棒状磁石（直線コース状磁石）と称するが、直線コース状磁石ではターゲット上に上方に凸の磁場トンネルができるが、これはレーストラック状磁石のように環状に閉じているものではないので、レーストラック状磁石の場合、環状ポロイダル磁場中をレースライン磁場の一端から発生し、長手方向に成長して行かねばならぬ。このとき、特別の電子発生装置がない場合にはこの部分に発生する電子が少なく長手方向にトロコイド運動をしながら進んでいった数を増してゆくのであるが、普通の条件ではプラズマが成長するまでに進まねばならぬ距離が10cmに

もなり、この間はプラズマは非常に弱いものである。しかし、上記の特別に電子を発生させる手段の一つを備えていれば、始めから十分な数の電子が存在し、プラズマは1~2cmで十分強くなり、プラズマの弱い部分は無視できるほど短くなる。

【0015】

【実施例】以下、この発明の実施例を図面に基づいて説明する。この発明の第1実施例は図1および図2に示されており、これらの図において、バックングプレート11の表面にはターゲット12が取り付けられ、また、バックングプレート1の裏面側には磁石装置13が配設されている。磁石装置13にはネジ棒をもった移動手段14が取り付けられ、この移動手段14によって磁石装置13がバックングプレート11の裏面に沿って直線移動するようになっている。磁石装置13は中央部磁石13aの廻りにこれと間隔をおいて配置された周縁部磁石13bとが備えられている。ターゲット12の上方にはこれと対向するように基板15が配置され、また、ターゲット12の端部の廻りには接地されたアースシールド16がターゲット12を取り囲むように端部と隙間をもって配置され、隙間にプラズマが流入しないようにしている。ターゲット12と基板15との間の空間にはリング状のアノード電極17が配置され、このアノード電極17は接地電位となっている。一方、バックングプレート11には負電圧が印加されている。ターゲット12の左右端部上方の空間には紫外線または近紫外線光源18が配置され、この光源18からの紫外線または近紫外線を当てて光電子をターゲット12の左端部の符号12aの場所および右端部の符号12bの場所に補給している。バックングプレート11内には冷却パイプ19が配設されている。

【0016】第1実施例においては、ターゲット12の表面近傍の空間において磁石装置13による湾曲したポロイダル磁場が形成されると共に、ターゲット12とアノード電極17との間の電位差による電場が形成され、これらの磁場と電場とによって直交電磁場が生じるようになる。しかしながら、移動手段14によって磁石装置13をバックングプレート11の裏面に沿って直線移動させるようにしているので、直交電磁場もそれに伴って移動し、高密度のプラズマがターゲット12の左端部と右端部との間で各端部においてはみ出すようになるまで動くようになる。その際、ターゲット12の左端部の符号12aの場所および右端部の符号12bの場所に光源18からの紫外線または近紫外線を当てて光電子を補給すると、磁石装置13がターゲット12よりはみ出している、プラズマ30は図17に示されるようにターゲット12の左端部又は右端部においても発生するようになる。電子はターゲット2の表面近傍の空間の直交電磁場により、これに垂直な方向で電場ベクトル(E)と磁場ベクトル(B)とのベクトル積(E×B)の向きに数

回のサイクロイドを描きながら運動する。この間にキャリア・ガス（普通アルゴンが用いられる）分子と衝突してエネルギーの一部を失った電子は、電子に対するポテンシャルの高いターゲット12には戻れず直交電磁場中をトロコイド軌道を描きながら、レース・トラック状のポロイダル磁場の中をドリフトしてゆく。1cmドリフトして行く間のトロコイド軌道の延べ軌道長は数十cmから数百cmに達する。此の間にキャリア・ガスと衝突してイオン化し、電子とイオンを発生させる（ $\alpha$ 作用）機会を生じ、生じた電子はやはりトロコイド軌道を描きながらドリフトし、生じたイオンはターゲット12へと加速されてこれと衝突し、ターゲット12の材料のスパッタと二次電子の放出を行い（ $\gamma$ （ガンマー）作用）、放出された二次電子は一次電子と同様のことをおこなう。この様にして、ターゲット12の表面近傍の空間にレース・トラック状のプラズマが成長する。しかし、ターゲット12の端部の廻りを取り囲むように、端部と隙間をもってアースシールド16を配置し、隙間にプラズマを流入させないようにしていると、プラズマはターゲット12の手前で切れ、アースシールド16までも広がらず、しかも、ターゲット12以外の物質をスパッタすることがなく、スパッタによる不純物の発生を防止させることができるようになる。

【0017】次に、第2実施例は図3および図4に示されている。第2実施例は第1実施例の紫外線または近紫外線光源18の代わりに、熱陰極20を用いて、熱電子を補給するものである。

【0018】第3実施例は図5および図6に示されている。第3実施例は第1実施例の紫外線または近紫外線光源18の代わりに、ターゲット12に高周波電力供給手段21を接続したものである。

【0019】第4実施例は図7および図8に示されている。第4実施例は第1実施例の紫外線または近紫外線光源18の代わりに、マイクロ波電力供給手段22を備えたものである。

【0020】第5実施例は図9および図10に示されている。第5実施例は第1実施例の磁石装置13の代わりに、少なくとも2つの棒状磁石（レースライン磁石）13c、13dを間隔をおいて平行に配置し、各棒状磁石13c、13dをターゲット12の端部と同方向に伸ばした磁石装置13を用いたものである。レースライン磁石は、上方にN極、下方にS極をもつ立方体磁石片を横一列に並べたもの、及び、上方にS極、下方にN極をもつ立方体磁石片を横一列に並べたものがあり、図9、図10のように配置されている。

【0021】第6実施例は図11および図12に示されている。第6実施例は第5実施例の紫外線または近紫外線光源18の代わりに、熱陰極20を用いて、熱電子を補給するものである。

【0022】第7実施例は図13および図14に示され

ている。第7実施例は第5実施例の紫外線または近紫外線光源18の代わりに、ターゲット12に高周波電力供給手段21を接続したものである。

【0023】第8実施例は図15および図16に示されている。第8実施例は第5実施例の紫外線または近紫外線光源18の代わりに、マイクロ波電力供給手段22を備えたものである。

【0024】

【発明の効果】この発明においては、磁石装置に移動手段を取り付け、この移動手段によって磁石装置をバックプレート裏面に沿って移動させ、その移動により高密度のプラズマをターゲットの一端部と他端部との間で各端部においてはみ出すようになるまで動かしているため、ターゲットの周縁部においてもスパッタされ、ターゲットが全体にわたって均等にスパッタされるようになる。また、ターゲットの端部の廻りを取り囲むように、端部と隙間をもってアースシールドを配置し、隙間にプラズマを流入させないようにしたときには、ターゲット以外の物質をスパッタすることがなくなるので、スパッタによる不純物の発生を防止させることができるようになる。更に、ターゲットの端部に電子を供給する電子供給手段、もしくは、ターゲットに接続する高周波電力供給手段、又は、マイクロ波電力供給手段を備えているときには、プラズマの出発点で光電子、熱電子の補給、RF電圧による強勢、又はマイクロ波によるECR放電が起り、プラズマを出発点から強くし、スパッタの不均一性を生じさせなくなる。更に、図17a、17bにプラズマの成長が示されている。レーストラック状磁石の一部が図17aのようにターゲットの外にまではみ出すような位置まで動いてくると、プラズマははみ出し部分はとぎれ、磁石がターゲットにかかっている部分から徐々に10cm位の暗部をへ発生するが、非常に弱い。しかし、光電子、熱電子、rf放電、マイクロ波による電子サイクロトロン放電（ECR）放電が端部にあって、十分な電子を補給すると、図17bのように端部1~2cmから太く強いプラズマが立ち、スパッタリングの端部における効率低下が全然起こらなくなり、ターゲットは全面的に均等にスパッタエロードされる。

【図面の簡単な説明】

【図1】この発明の第1実施例の正面図

【図2】この発明の第1実施例の平面図

【図3】この発明の第2実施例の正面図

【図4】この発明の第2実施例の平面図

【図5】この発明の第3実施例の正面図

【図6】この発明の第3実施例の平面図

【図7】この発明の第4実施例の正面図

【図8】この発明の第4実施例の平面図

【図9】この発明の第5実施例の正面図

【図10】この発明の第5実施例の平面図

【図11】この発明の第6実施例の正面図

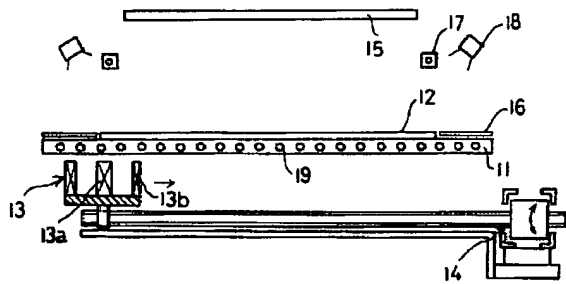
- 【図12】 この発明の第6実施例の平面図
- 【図13】 この発明の第7実施例の正面図
- 【図14】 この発明の第7実施例の平面図
- 【図15】 この発明の第8実施例の正面図
- 【図16】 この発明の第8実施例の平面図
- 【図17 a】 この発明の第1実施例においてプラズマの成長を示す説明図
- 【図17 b】 この発明の第1実施例においてプラズマの成長を示す説明図
- 【図18】 従来のマグネトロンスパッタ装置の正面図
- 【図19】 従来のマグネトロンスパッタ装置の平面図
- 【図20】 従来のマグネトロンスパッタ装置の斜視図
- 【図21】 従来のマグネトロンスパッタ装置の磁場等を示す説明図
- 【図22】 従来のマグネトロンスパッタ装置の正面図

【図23】 従来のマグネトロンスパッタ装置における磁石装置の移動を示す説明図

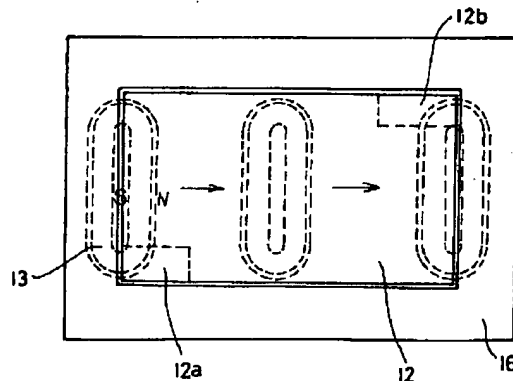
【符号の説明】

- 11.....バックングプレート
- 12.....ターゲット
- 13.....磁石装置
- 14.....移動手段
- 15.....基板
- 16.....アースシールド
- 17.....アノード電極
- 18.....光源
- 20.....熱陰極
- 21.....高周波電力供給手段
- 22.....マイクロ波電力供給手段

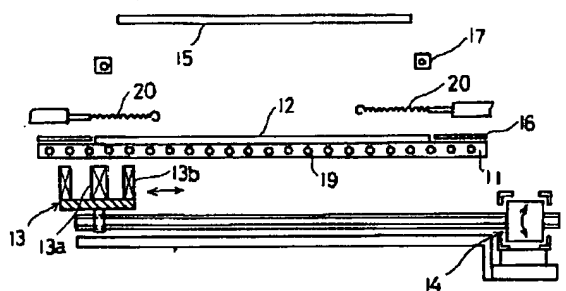
【図1】



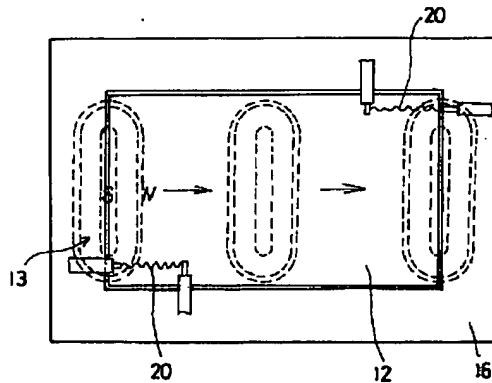
【図2】



【図3】

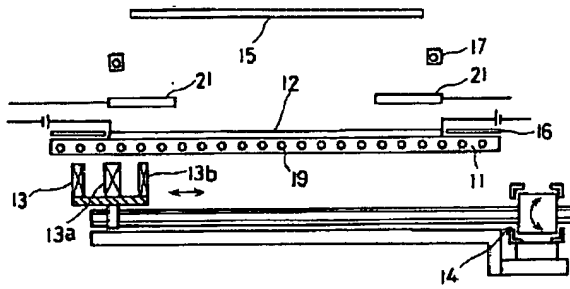


【図4】

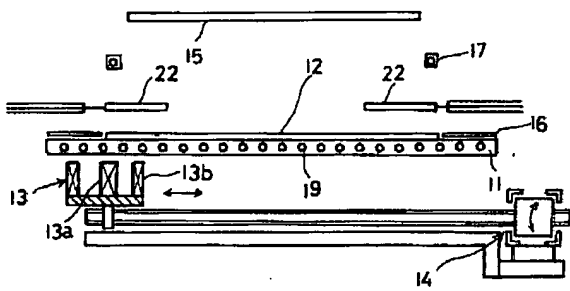




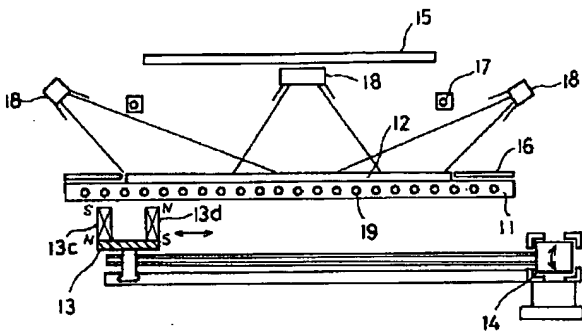
【図5】



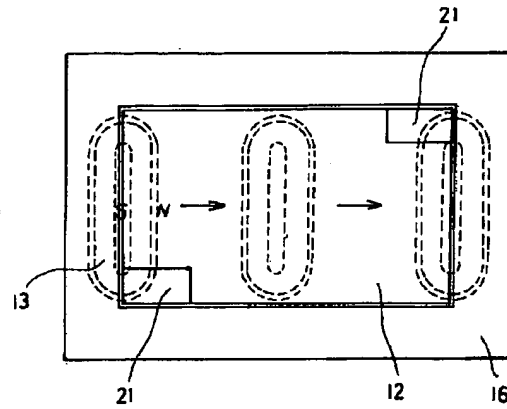
【図7】



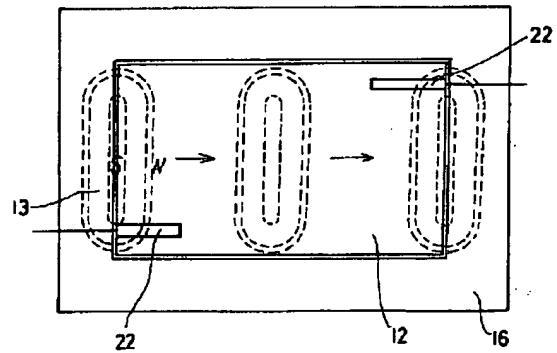
【図9】



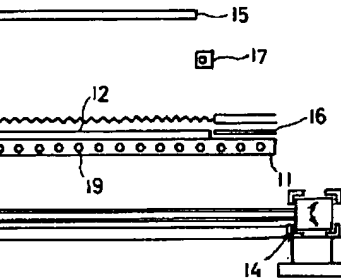
【図6】



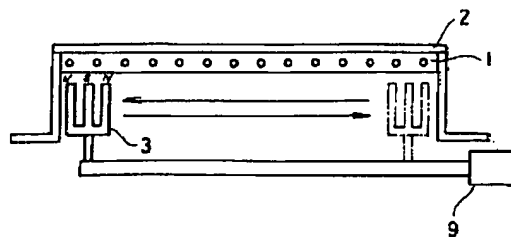
【図8】



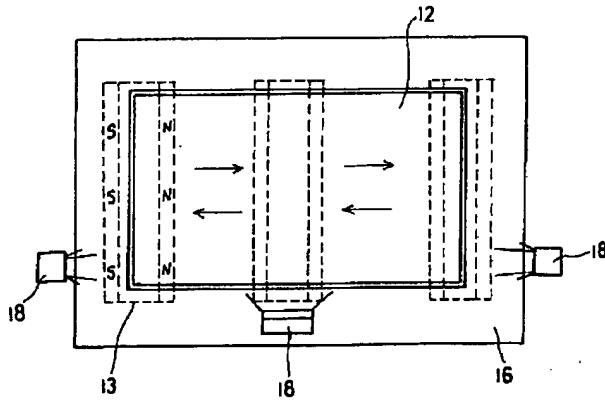
【図11】



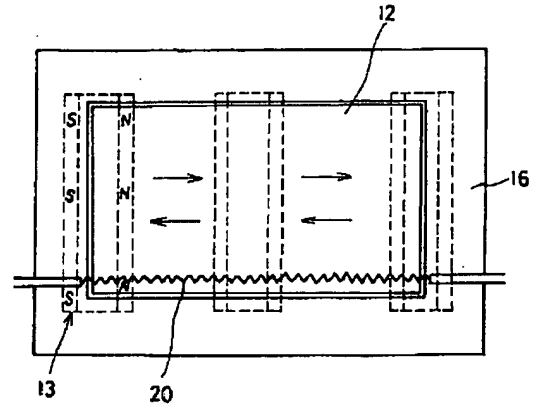
【図22】



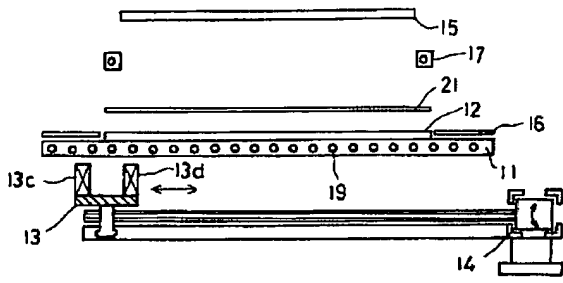
【図10】



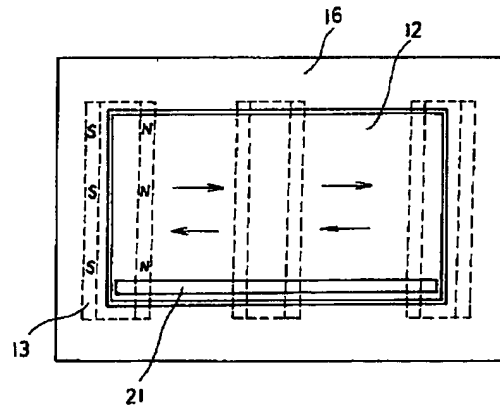
【図12】



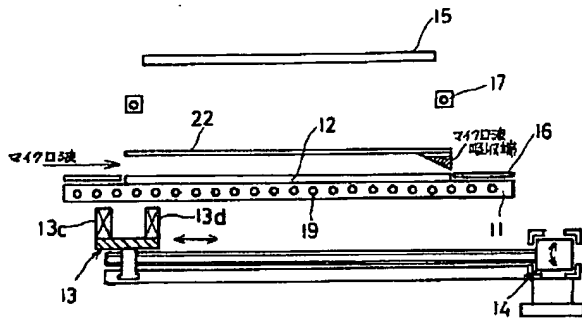
【図13】



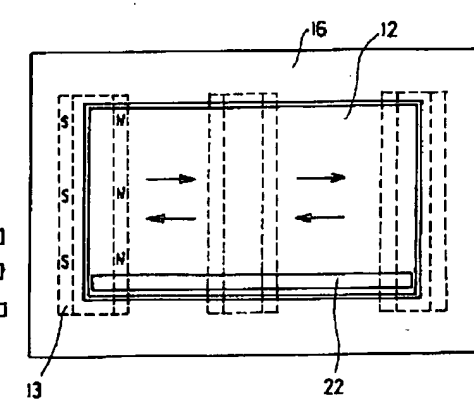
【図14】



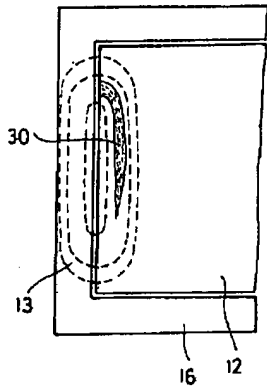
【図15】



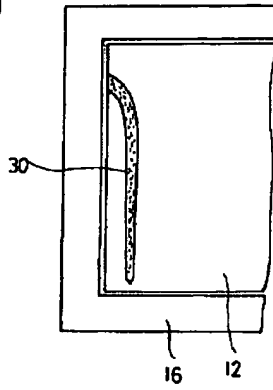
【図16】



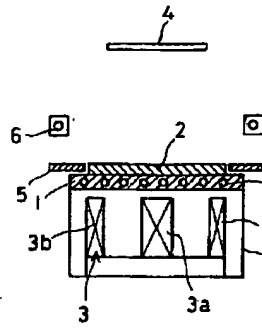
【図17a】



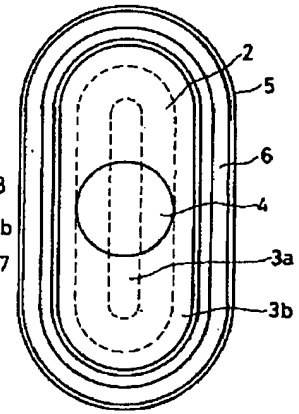
【図17b】



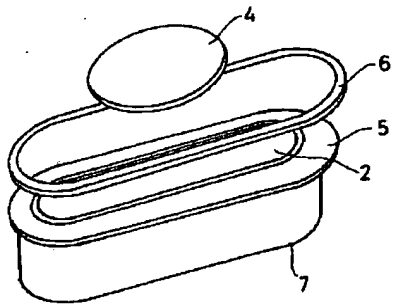
【図18】



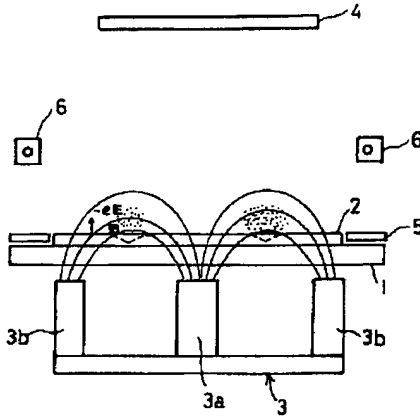
【図19】



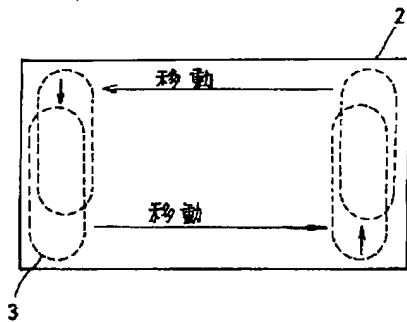
【図20】



【図21】



【図23】



This Page Is Inserted by IFW Operations  
and is not a part of the Official Record

## **BEST AVAILABLE IMAGES**

Defective images within this document are accurate representations of the original documents submitted by the applicant.

Defects in the images may include (but are not limited to):

- BLACK BORDERS
- TEXT CUT OFF AT TOP, BOTTOM OR SIDES
- FADED TEXT
- ILLEGIBLE TEXT
- SKEWED/SLANTED IMAGES
- COLORED PHOTOS
- BLACK OR VERY BLACK AND WHITE DARK PHOTOS
- GRAY SCALE DOCUMENTS

**IMAGES ARE BEST AVAILABLE COPY.**

**As rescanning documents *will not* correct images,  
please do not report the images to the  
Image Problem Mailbox.**

**WEST**

**Generate Collection**

L33: Entry 2 of 3

File: DWPI

Apr 12, 1994

DERWENT-ACC-NO: 1994-156455  
 DERWENT-WEEK: 199419  
 COPYRIGHT 2003 DERWENT INFORMATION LTD

TITLE: Metal ion implanted surface modified glass - by ion implanting metal ions e.g. copper and/or silver, into a glass substrate surface to form a modified layer

PATENT-ASSIGNEE:  
 ASSIGNEE CODE  
 KOBE STEEL LTD KOBM

PRIORITY-DATA: 1992JP-0246692 (September 16, 1992)

PATENT-FAMILY:	PUB-NO	PUB-DATE	LANGUAGE	PAGES	MAIN-IPC
	JP 06100333 A	April 12, 1994		005	C03C021/00

APPLICATION-DATA:	PUB-NO	APPL-DATE	APPL-NO	DESCRIPTOR
	JP 06100333A	September 16, 1992	1992JP-0246692	

INT-CL (IPC): C03C 21/00

ABSTRACTED-PUB-NO: JP 06100333A  
 BASIC-ABSTRACT:

The glass is obtd. by ion implanting metal ions e.g. Cu and/or Ag ions into a glass substrate surface to form a modified layer for absorbing and reflecting a particular wavelength light ray selectively onto the surface layer part of the glass substrate.

USE - Used for giving unique optical characteristics to a glass substrate.

CHOSEN-DRAWING: Dwg.0/4

TITLE-TERMS: METAL ION IMPLANT SURFACE MODIFIED GLASS ION IMPLANT METAL ION COPPER SILVER GLASS SUBSTRATE SURFACE FORM MODIFIED LAYER

DERWENT-CLASS: L01

CPI-CODES: L01-G05A;

SECONDARY-ACC-NO:  
 CPI Secondary Accession Numbers: C1994-071675

(19)日本国特許庁 (J.P)

(12) 公開特許公報 (A)

(11)特許出願公開番号

特開平6-100333

(43)公開日 平成6年(1994)4月12日

(51)Int.Cl.<sup>4</sup>  
C03C 21/00

識別記号 庁内整理番号  
Z 7003-4G  
102 7003-4G

F1

技術表示箇所

審査請求 未請求 請求項の数1(全5頁)

(21)出願番号 特願平4-246692  
(22)出願日 平成4年(1992)9月16日

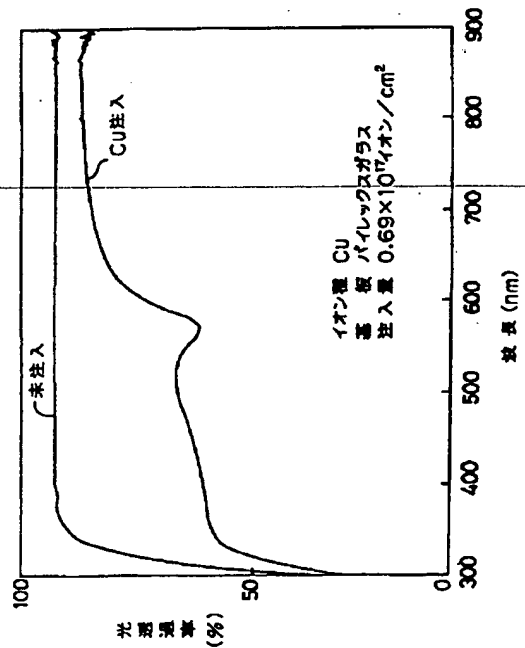
(71)出願人 000001199  
株式会社神戸製鋼所  
兵庫県神戸市中央区臨浜町1丁目3番18号  
(72)発明者 犬石 典之  
兵庫県神戸市中央区臨浜町1丁目3番18号  
株式会社神戸製鋼所神戸本社内  
(72)発明者 宗政 淳  
兵庫県神戸市中央区臨浜町1丁目3番18号  
株式会社神戸製鋼所神戸本社内  
(72)発明者 熊切 正  
兵庫県神戸市中央区臨浜町1丁目3番18号  
株式会社神戸製鋼所神戸本社内  
(74)代理人 弁理士 植木 久一

(54)【発明の名称】 金属イオン注入表面改質ガラス

(57)【要約】

【目的】 イオン注入法を適用して特定の金属イオンをガラス基板に注入することによって、これまでにない新しい光学特性を付与した金属イオン注入表面改質ガラスを提供する。

【構成】 ガラス基板表面に、Cuおよび/またはAgの金属元素をイオン注入し、ガラス基板の表層部に、特定波長の光を選択的に吸収・反射する改質層を形成したものである。



1

【特許請求の範囲】

【請求項1】 ガラス基板表面に、Cuおよび/またはAgの金属元素をイオン注入し、ガラス基板の表層部に、光の選択的透過層を形成したものであることを特徴とする金属イオン注入表面改質ガラス。

【発明の詳細な説明】

【0001】

【産業上の利用分野】本発明は、特定波長の光を選択的に吸収および/または反射して透過させないマイナスフィルターと呼ばれる光学素子の素材として、或は建築物や自動車用の紫外線カットガラスとして有用な、金属イオン注入表面改質ガラスに関するものである。

【0002】

【従来の技術】ガラス製品は、例えば画像や文字を表示するディスプレイ、太陽光を利用するソーラーセルや太陽電池、建築物や自動車の窓等、様々な分野で利用されている。そしてディスプレイにおける表示を正確で美しいものとする為、またソーラーセルや太陽電池における効率を良くする為、更には快適な居住空間を形成する為には、これらに使用されるガラス製品の光吸収や光反射を適切に調節して光を有効に利用することが重要である。

【0003】近年、ガラス製品に上記の様な機能を付与する為の方法が、様々な角度から検討されている。その代表的な方法としては、ガラス基板表面にコーティング膜を形成する方法が挙げられる。例えば太陽光の熱線を遮蔽して、夏期における室内の冷房負荷が大きくなるのを防止する目的で、TiO<sub>2</sub>、CoO等の金属酸化物膜を熱分解法によってガラス基板表面にコーティングしたガラスが開発されている。また真空蒸着法やスパッタ法によって、TiやCrの様な金属膜を、ガラス基板表面にコーティングしたガラスも知られている。一方、特定の波長の光を選択的に吸収または透過させる光学フィルターにおいても、ガラス基板に屈折率の異なる薄膜をコーティングしたガラスが知られている。

【0004】しかしながらガラス基板にコーティング膜を形成したのでは、ガラス基板とコーティング膜の密着性が十分でなく、外部からの衝撃によって疵が付き易いという欠点がある。また腐食性環境下では、コーティング膜が変質してしまい、光学特性が変化してしまうという欠点もある。こうした不都合を回避する技術として、例えば特開平3-257042号公報の様な技術も提案されている。この技術は、Si、Al、Ti、Cr、Co、Ni等の元素を、イオン注入法によってガラス基板に打ち込み、該ガラス基板の内部の表面近傍に光の選択的透過層を形成して、光透過率を調整するものであり、上記の様な不都合を基本的に含まない新しい技術として注目されている。

【0005】

【発明が解決しようとする課題】本発明はこうした状況

2

の基になされたものであって、その目的は、イオン注入法を適用して特定の金属イオンをガラス基板に注入することによって、これまでにない新しい光学特性を付与した金属イオン注入表面改質ガラスを提供することにある。

【0006】

【課題を解決するための手段】上記目的を達成し得た本発明とは、ガラス基板表面に、Cuおよび/またはAgの金属元素をイオン注入し、ガラス基板の表層部に、光の選択的透過層を形成したものである点に要旨を有する金属イオン注入表面改質ガラスである。

【0007】

【作用】本発明で利用されるイオン注入の手法は、加速された高エネルギーの金属イオンを目的深さまで打ち込んでガラス基板の表層部を改質するものであり、半導体分野における不純物ドーピング手段として利用されている他、鋼を中心とする金属材料の表面改質にもその適用が進められているが、半導体分野を除けばこれまでのところ実用化はあまり進んでいなかった。

【0008】本発明者らは、かねてよりイオン注入法について研究を進めてきており、種々の材料に対するイオン注入による表面改質について検討してきた。そして近年の状況に鑑み、且つ研究の一環として、種々の金属イオンについてのイオン注入実験を重ね、ガラス基板の光学特性に及ぼす金属イオンの影響について検討した。その結果、ガラス基板にCuやAg等の金属元素をイオン注入すれば、ガラス基板の表層部に、特定波長の光を選択的に吸収・反射する改質層が形成され、これによってガラス基板に特異な光学特性を付与できることを見出し、本発明を完成した。即ち本発明者らが、CuやAgをイオン注入した表面改質ガラスについて、その光透過率を調査したところ、後記実施例に示す様に、Cuをイオン注入した場合は波長580nm近傍に、Agをイオン注入した場合は波長420nm近傍に透過率減少ピークが夫々形成されることがわかった。

【0009】この様に、特定波長の光を選択的に透過する表面改質ガラスは、その光学特性を利用してマイナスフィルターの素材としての適用が期待できる。即ち、Cuをイオン注入した場合は、波長が590~430nm程度の範囲の光(黄、緑、青、紫色光)を吸収・反射して、これらの光を透過させないマイナスフィルターの素材としての適用が期待できる。またAgをイオン注入した場合は、波長が490~380nm程度の範囲の光(青、紫色光)を吸収・反射して、これらの光を透過させないマイナスフィルターの素材としての適用が期待できる。

【0010】またCuまたはAgのいずれをイオン注入した場合であっても、未処理のガラス基板に比べ、紫外線領域(波長380nm以下)における光透過率が低下するので、本発明のガラスは紫外線カットガラスとしての

50

3

4

適用も考えられる。更に、イオン注入することによって、ガラス基板はピンク色(Cuをイオン注入した場合)や黄色(Agをイオン注入した場合)等に着色されるので本発明の表面改質ガラスは、装飾用ガラスとしての応用も考えられる。尚これまでの説明では、CuまたはAgのいずれかを単独でイオン注入する場合について説明したが、もとより両者を複合的にイオン注入することも可能であり、この場合は複合的な透過率減少ピークが認められる。

【0011】本発明の表面改質ガラスは上記作用効果を奏するものであるが、これらの作用効果を得るには、金属イオンを夫々または合計で $1 \times 10^{15}$ イオン/cm<sup>2</sup>以上注入するのが良い。またガラス表面の耐摩耗性や耐薬品性を考慮すると、金属イオンの注入位置はできるだけ深い方が好ましく、こうした観点からして、注入エネルギーは30KeV以上とするのが良い。一方、過剰にイオン注入すると、注入エネルギーに応じてスパッタ現象による表面切削現象が顕著になるので、注入エネルギーおよび注入量は慎重に決定する必要がある。こうした観点か\*

\*らすれば、注入エネルギーは250 KeV以下とし、且つ注入量は $5 \times 10^{18}$ イオン/cm<sup>2</sup>以下に抑えることが望ましい。

【0012】本発明においては、CuやAgの高エネルギーイオンをガラス基板の表層部に強制的に注入するが、表面にコーティング膜を形成する場合と異なり、イオン注入表面層とガラス基板との一体性は極めて良好であり、剥離の問題は生じない。また表面はガラス基板本来の耐食性を維持したままである。

10 【0013】以下本発明を実施例によって更に詳細に説明するが、下記実施例は本発明を限定する性質のものではなく、前・後記の趣旨に倣して設計変更することはいずれも本発明の技術的範囲に含まれるものである。

【0014】

【実施例】表1に示す各種イオン注入ガラスについて、光透過率の測定を、可視・紫外領域(波長300~900nm)について行なった。

【0015】

【表1】

No.	注入イオン種	ガラス基板	注入エネルギー (KeV)	注入量 (イオン/cm <sup>2</sup> )
1	Cu	バイレックスガラス	119	$0.69 \times 10^{17}$
2	Cu	スライドガラス	119	$0.82 \times 10^{17}$
3	Ag	バイレックスガラス	124	$0.69 \times 10^{17}$
4	Ag	スライドガラス	124	$0.64 \times 10^{17}$

【0016】その結果を図1~4に示すが、いずれも特定波長領域に特異的な透過率減少ピークが認められ、マイナスフィルターとして有用なガラスができていことがわかる。また未注入のガラス基板の透過率と比較して明らかな様に(図1および図3)、紫外線(波長380nm以下)の透過率も低下していることから、本発明の表面改質ガラスは紫外線カットガラスとしての適用も可能である。

【0017】

【発明の効果】本発明は以上の様に構成されており、CuやAg等の金属元素をイオン注入することによって、特定波長の光を選択的に吸収・反射して透過させないマ※

※イナスフィルターの素材として、或は紫外線カットガラスとして有用な表面改質ガラスが得られた。

【図面の簡単な説明】

【図1】バイレックスガラス基板にCuをイオン注入したガラスの分光曲線である。

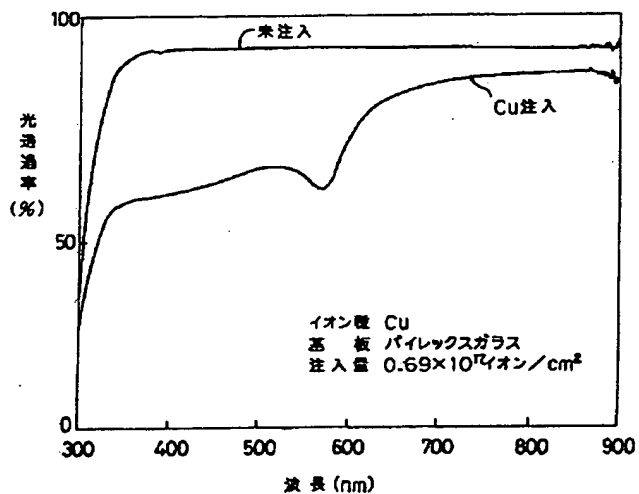
40 【図2】スライドガラス基板にCuをイオン注入したガラスの分光曲線である。

【図3】バイレックスガラス基板にAgをイオン注入したガラスの分光曲線である。

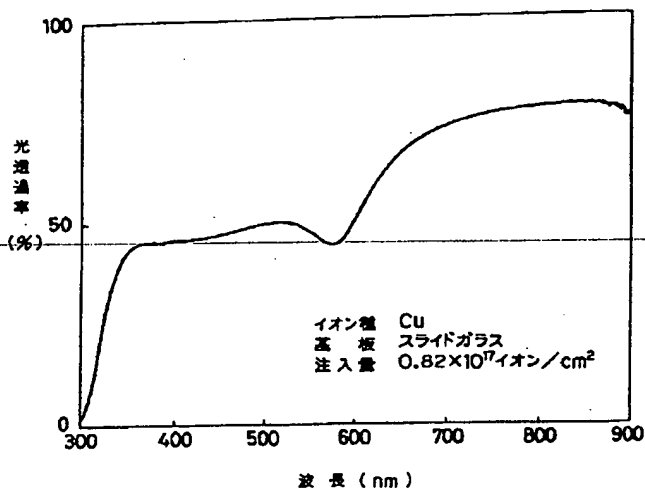
【図4】スライドガラス基板にAgをイオン注入したガラスの分光曲線である。



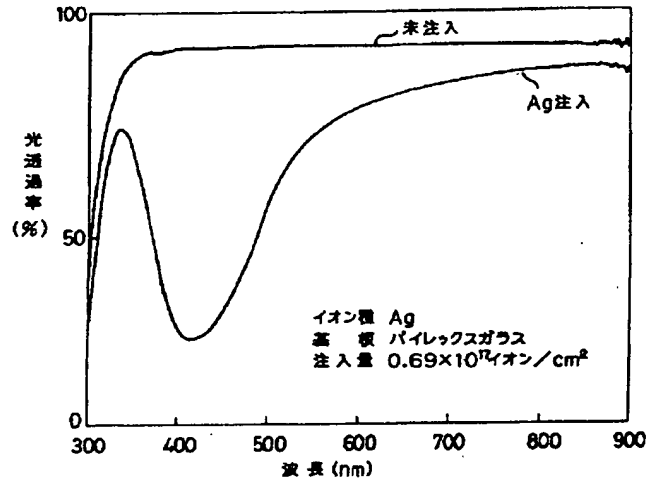
【図1】



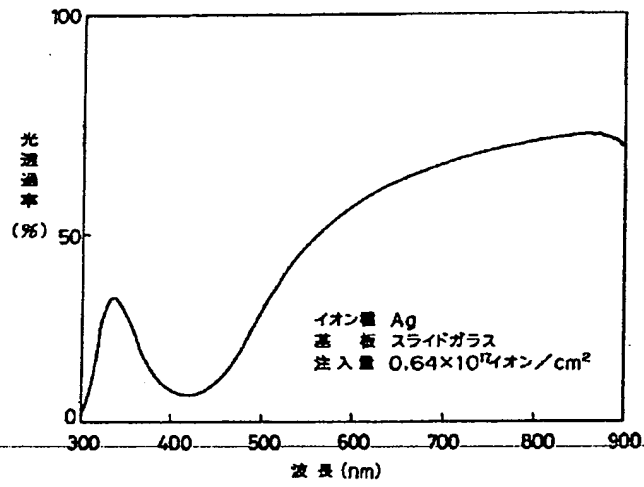
【図2】



【図3】



【図4】

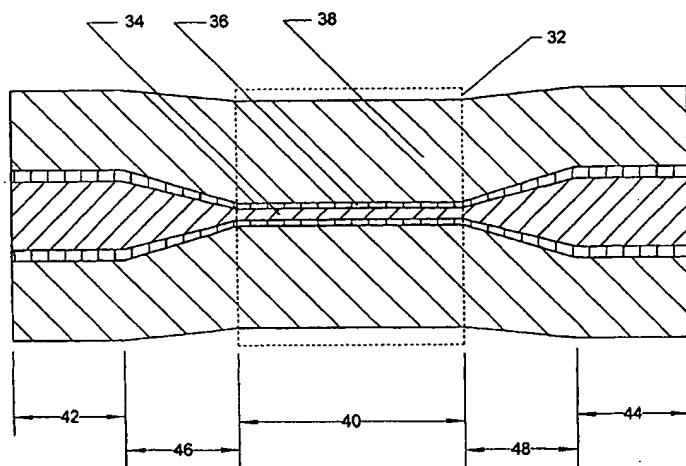




INTERNATIONAL APPLICATION PUBLISHED UNDER THE PATENT COOPERATION TREATY (PCT)

<p>(51) International Patent Classification <sup>7</sup> : <b>H04B</b></p>	<p><b>A2</b></p>	<p>(11) International Publication Number: <b>WO 00/22742</b> (43) International Publication Date: 20 April 2000 (20.04.00)</p>
<p>(21) International Application Number: PCT/US99/22102 (22) International Filing Date: 23 September 1999 (23.09.99) (30) Priority Data: 60/101,853 25 September 1998 (25.09.98) US 09/246,985 9 February 1999 (09.02.99) US (71) Applicant: FIVER LABORATORIES [US/US]; Suite 316, 48521 Warm Springs Blvd., Fremont, CA 94539 (US). (72) Inventors: WU, Weiti; 328 Sandhurst Drive, Milpitas, CA 95035 (US). KO, Yu-Li; 45654 Cheyenne Place, Fremont, CA 94539 (US). CHUNG, Gary; 41366 Charlita Court, Fremont, CA 94539 (US). (74) Agents: HAVERSTOCK, Thomas, B. et al.; Haverstock &amp; Owens LLP, Suite 420, 260 Sheridan Avenue, Palo Alto, CA 94306 (US).</p>	<p>(81) Designated States: AE, AL, AM, AT, AU, AZ, BA, BB, BG, BR, BY, CA, CH, CN, CU, CZ, DE, DK, EE, ES, FI, GB, GD, GE, GH, GM, HR, HU, ID, IL, IN, IS, JP, KE, KG, KP, KR, KZ, LC, LK, LR, LS, LT, LU, LV, MD, MG, MK, MN, MW, MX, NO, NZ, PL, PT, RO, RU, SD, SE, SG, SI, SK, SL, TJ, TM, TR, TT, UA, UG, UZ, VN, YU, ZA, ZW, ARIPO patent (GH, GM, KE, LS, MW, SD, SL, SZ, TZ, UG, ZW), Eurasian patent (AM, AZ, BY, KG, KZ, MD, RU, TJ, TM), European patent (AT, BE, CH, CY, DE, DK, ES, FI, FR, GB, GR, IE, IT, LU, MC, NL, PT, SE), OAPI patent (BF, BJ, CF, CG, CI, CM, GA, GN, GW, ML, MR, NE, SN, TD, TG).</p> <p><b>Published</b> <i>Without international search report and to be republished upon receipt of that report.</i></p>	

(54) Title: ALL FIBER GAIN FLATTENING OPTICAL FILTER



(57) Abstract

An all fiber optical filter is formed by stretching an optical fiber. The all fiber filter includes a core, an inner cladding, and an outer cladding. A core index of refraction is greater than an outer cladding index of refraction. The outer cladding index of refraction is greater than an inner cladding index of refraction. The all fiber optical filter attenuates a portion of an optical signal by transferring optical energy from the core to the outer cladding by evanescent coupling. The all fiber optical filter has a compact structure, which prevents bending and provides stable temperature performance. The all fiber optical filter is preferably used in Wavelength Division Multiplexing (WDM) systems for gain flattening of gain responses from Erbium Doped Fiber Amplifiers (EDFAs). Alternatively, the all fiber optical filter is used in other applications where optical filtering or attenuation is needed. The all fiber optical filter is manufactured by holding a length of an appropriate optical fiber between two clamps, heating the optical fiber, stretching the optical fiber until a predetermined characteristic of the all fiber optical filter is achieved.

**FOR THE PURPOSES OF INFORMATION ONLY**

Codes used to identify States party to the PCT on the front pages of pamphlets publishing international applications under the PCT.

AL	Albania	ES	Spain	LS	Lesotho	SI	Slovenia
AM	Armenia	FI	Finland	LT	Lithuania	SK	Slovakia
AT	Austria	FR	France	LU	Luxembourg	SN	Senegal
AU	Australia	GA	Gabon	LV	Latvia	SZ	Swaziland
AZ	Azerbaijan	GB	United Kingdom	MC	Monaco	TD	Chad
BA	Bosnia and Herzegovina	GE	Georgia	MD	Republic of Moldova	TG	Togo
BB	Barbados	GH	Ghana	MG	Madagascar	TJ	Tajikistan
BE	Belgium	GN	Guinea	MK	The former Yugoslav Republic of Macedonia	TM	Turkmenistan
BF	Burkina Faso	GR	Greece	ML	Mali	TR	Turkey
BG	Bulgaria	HU	Hungary	MN	Mongolia	TT	Trinidad and Tobago
BJ	Benin	IE	Ireland	MR	Mauritania	UA	Ukraine
BR	Brazil	IL	Israel	MW	Malawi	UG	Uganda
BY	Belarus	IS	Iceland	MX	Mexico	US	United States of America
CA	Canada	IT	Italy	NE	Niger	UZ	Uzbekistan
CF	Central African Republic	JP	Japan	NL	Netherlands	VN	Viet Nam
CG	Congo	KE	Kenya	NO	Norway	YU	Yugoslavia
CH	Switzerland	KG	Kyrgyzstan	NZ	New Zealand	ZW	Zimbabwe
CI	Côte d'Ivoire	KP	Democratic People's Republic of Korea	PL	Poland		
CM	Cameroon	KR	Republic of Korea	PT	Portugal		
CN	China	KZ	Kazakstan	RO	Romania		
CU	Cuba	LC	Saint Lucia	RU	Russian Federation		
CZ	Czech Republic	LJ	Liechtenstein	SD	Sudan		
DE	Germany	LK	Sri Lanka	SE	Sweden		
DK	Denmark	LR	Liberia	SG	Singapore		
EE	Estonia						

## ALL FIBER GAIN FLATTENING OPTICAL FILTER

### RELATED APPLICATIONS

This application claims priority under 35 U.S.C. § 119(e) of the co-pending U.S. provisional application Serial Number 60/101,853 filed on September 25, 1998 and entitled "ALL-FIBER EDFA GAIN FLATTENING FILTER." The provisional application Serial Number 60/101,853 filed on September 25, 1998 and entitled "ALL-FIBER EDFA GAIN FLATTENING FILTER" is also hereby incorporated by reference.

### FIELD OF THE INVENTION

The present invention relates to the field of fiber optic communications. More particularly, the present invention relates to the field of filtering of amplified signals used in fiber optic communications systems.

### BACKGROUND OF THE INVENTION

Fiber optic communication systems use optical fibers to carry a modulated lightwave signal between a transmitter and a receiver. A cross-section of a typical optical fiber is illustrated in FIG. 1. The optical fiber 2 includes a core 4 and a cladding 6. Optionally, the optical fiber 2 includes a jacket 8. In a typical optical fiber, the core 4 has an index of refraction greater than the cladding 6, thereby forming an optical waveguide. By maintaining the core diameter within an allowed range, light traveling within the core 4 is limited to a single mode. If included, the jacket 8 protects the outer surface of the cladding 6 and absorbs stray light traveling within the cladding 6. A typical single mode optical fiber intended for use in communication systems operating at a 1300 nm wavelength band or a 1550 nm wavelength band has a core diameter of about 8  $\mu\text{m}$  and a cladding outside diameter of 125  $\mu\text{m}$ . If the jacket 8 is included, the jacket 8 typically has an outside diameter of 250  $\mu\text{m}$ .

In Wavelength Division Multiplexing (WDM) systems, multiple signals are carried by various wavelengths of light through a single optical fiber. A typical WDM system is shown in FIG. 2. The WDM system 10 includes a transmission system 11, which includes a series of transmitters 12, 14, and 16, each coupled to a multiplexer 18. The multiplexer 18 provides an output, which is coupled to an optical fiber 20. Over long distances amplifiers 22 are included along the optical fiber 20. The optical fiber 20 is then also

coupled to a receiving system 23, which includes a demultiplexer 24 and a series of receivers 26, 28, and 30. The optical fiber 20 is coupled to an input of the demultiplexer 24 of the receiving system 23. Outputs of the demultiplexer 24 are coupled to the series of receivers 26, 28, and 30.

5 In the WDM system 10, a first transmitter 12 transmits a light signal at a first wavelength ( $\lambda_1$ ), a second transmitter 14 transmits a light signal at a second wavelength ( $\lambda_2$ ), and so forth until an nth transmitter 16 transmits a light signal at an nth wavelength ( $\lambda_n$ ). The shortest wavelength signal and the longest wavelength signal form a wavelength band. The signals are combined by the multiplexer 18, which then transmits the light  
10 signals along the optical fiber 20. Over distance the power of the light signals decrease due to attenuation. The light signals are typically amplified about every 50 - 100 km. For the 1550 nm wavelength band, this amplification is generally performed by an Erbium Doped Fiber Amplifier (EDFA) 22. When the light signals reach their destination they are separated by the demultiplexer 24. The light signals are then received by the receivers 26,  
15 28, and 30. Light signal intensity versus wavelength for a typical wavelength band of WDM light signals is illustrated in FIG. 3.

Flat gain response for EDFAs is crucial to the performance of the WDM system 10, since small variations in gain for various wavelengths will grow exponentially over a series of in-line EDFAs 22. Agrawal in "Fiber Optic Communication Systems," (Wiley, 2nd ed.,  
20 1997, pp 414 - 415) teaches that numerous methods can be used to flatten the gain response of these amplifiers. One method of flattening this gain response is to use channel filters to equalize the gain for various wavelengths. Another method is to adjust the input powers of different wavelengths so that amplification results in uniform intensity for various wavelengths. A third method is to use inhomogeneous broadening of the EDFA  
25 gain spectrum to equalize wavelength intensity. A fourth method is to use multiple EDFAs tuned to different wavelength ranges and configured with feedback loops. A final method is to use a filter or series of filters to selectively attenuate the gain response of an EDFA.

A typical gain versus wavelength response for an EDFA is shown in FIG. 4A. When utilizing a filter or series of filters to flatten gain response, an optical filter, with an  
30 attenuation curve as shown in FIG. 4B, can be used to selectively attenuate the gain response. The resulting attenuated EDFA gain is shown in FIG. 4C. As shown in FIG.

4C, this attenuated EDFA gain is substantially flat over a range of wavelengths including 1530 nm to 1560 nm. Without a substantially flat gain, the quality of the signal received by the receivers 26, 28, and 30 will be poor.

5 There are many different known methods for selectively attenuating the gain response of an EDFA in order to improve the signal quality of the signals received by the receivers 26, 28, and 30. U.S. Pat. No. 5,260,823 to Payne et al. entitled, "Erbium-Doped Fibre Amplifier with Shaped Spectral Gain," teaches that a wavelength-selective resonant coupling between a propagating core mode to a cladding leaky mode can be used for filtering a wavelength band for EDFA gain flattening. A periodic perturbation of the core forms a grating and the selected wavelength is attenuated by the resonant coupling between  
10 the core and the cladding. By varying the perturbation length, various selected wavelengths can be attenuated. Payne et al. also teach that multilayered dielectric coatings can be used for making an optical filter for EDFA gain flattening. A multilayered filtering apparatus includes two coupling lenses and a multilayered dielectric filter. The two  
15 coupling lenses connect to an optical fiber and sandwich the multilayered dielectric filter. The multilayered dielectric filter is designed to cancel out the larger gain around the peak wavelength and to be transparent elsewhere.

U.S. Pat. No. 5,473,714 to Vengsarkar entitled, "Optical Fiber System Using Tapered Fiber Devices," teaches that tapered fiber devices can be used for filtering in an  
20 optical telecommunications system. Vengsarkar teaches that by tapering an optical fiber, light can be attenuated by wavelength cutoff and direct coupling from a core to a cladding. The tapered fiber device is formed from the optical fiber by heating the optical fiber and stretching it. The taper reduces the diameter of the core to a value close to the cutoff wavelength. Light with wavelengths near and above the cutoff wavelength are coupled  
25 directly to the cladding.

U.S. Pat. No. 5,583,689 to Cassidy et al. entitled "Filter With Preselected Attenuation/Wavelength Characteristic," teaches that a fiber grating, with spatially separated parts having different attenuation characteristics, can perform filtering for EDFA gain flattening. The fiber grating is preferably a side-tap Bragg fiber grating. By varying the  
30 pitch along the fiber grating an appropriate attenuation profile can be provided for flattening the EDFA gain response.

U.S. Pat. No. 5,067,789 to Hall et al. entitled, "Fiber Optical Coupling Filter and Amplifier," teaches that a light-attenuating light path adjacent to a first core within a cladding can be used to filter wavelengths about a specific wavelength for EDFA gain flattening. The light attenuating light path is preferably one or more lossy cores that are evanescently coupled to the first core. The evanescent coupling between the first core and the light attenuating light path is greatest where the effective index of refraction of the first core equals the effective index of refraction of the light attenuating light path. By choosing a single mode or a higher multimode optical waveguide structure for the light attenuating light path, the effective index of refraction for the light attenuating light path can be varied. Hall et al. teach that the index of refraction for the material for the light attenuating light path should be greater than the index of refraction for the material for the first core. Hall et al. further teach that as an alternative embodiment the lossy core could be a lossy annular region located concentrically about the first core and within the cladding. A necessary feature of this filter is that the lossy core or the lossy annular region has specific light absorption characteristics. Since the lossy core or the lossy annular region is contained completely within the cladding, the specific light absorption characteristics dissipates light energy that has been filtered from the first core to the lossy core or the lossy annular region. The absorption characteristics of the lossy core or the lossy annular region determine an amount of attenuation of the filtered wavelengths.

Each of these known methods for filtering an amplified signal from an EDFA can be inefficient, unreliable, and expensive. There is currently a lack of efficient filters for gain flattening in fiber optic systems, which are easy to manufacture and use within a WDM system.

#### SUMMARY OF THE INVENTION

An all fiber optical filter is formed by stretching an optical fiber. The all fiber filter includes a core, an inner cladding, and an outer cladding. A core index of refraction is greater than an outer cladding index of refraction. The outer cladding index of refraction is greater than an inner cladding index of refraction. The all fiber optical filter attenuates a portion of an optical signal by transferring optical energy from the core to the



outer cladding by evanescent coupling. The all fiber optical filter has a compact structure, which prevents bending and provides stable temperature performance.

The all fiber optical filter is preferably used in Wavelength Division Multiplexing (WDM) systems for gain flattening of gain responses from Erbium Doped Fiber Amplifiers (EDFAs). Alternatively, the all fiber optical filter is used in other applications where optical filtering or attenuation is needed.

The all fiber optical filter is manufactured by holding a length of an appropriate optical fiber between two clamps, heating the optical fiber, and stretching the optical fiber until a predetermined characteristic of the optical fiber is achieved.

10

#### BRIEF DESCRIPTION OF THE DRAWINGS

FIG. 1 illustrates a cross section of an optical fiber of the prior art.

FIG. 2 illustrates a block diagram of a WDM system of the prior art.

FIG. 3 illustrates a graph of intensity versus wavelength for a wavelength band of WDM light signals of the prior art.

15

FIG. 4A illustrates an EDFA gain curve over a range of wavelengths of the prior art.

FIG. 4B illustrates a filter attenuation curve over a range of wavelengths for gain band flattening of the prior art.

FIG. 4C illustrates an attenuated EDFA gain curve over a range of wavelengths using a filter of the prior art.

20

FIG. 5 illustrates a linear cross section of an all fiber optical filter of the present invention.

FIG. 6 illustrates a cross-section of the all fiber optical filter of the present invention.

25

FIG. 7 illustrates the all fiber optical filter and additional structure of the present invention.

FIGS. 8A, 8B, and 8C illustrate configurations including an EDFA, a first all fiber optical filter, and a second all fiber optical filter of the present invention.

FIGS. 9A and 9B illustrate intensity versus wavelength for an EDFA gain response and a filtered EDFA gain response of the present invention.

30

FIG. 10 illustrates an EDFA and an all fiber optical filter of the present invention.

FIG. 11 illustrates a WDM system including the all fiber optical filter of the present invention.

FIG. 12 illustrates a first apparatus for making the all fiber optical filter of the present invention.

FIG. 13 illustrates a second apparatus for making the all fiber optical filter of the present invention.

#### DETAILED DESCRIPTION OF THE PREFERRED EMBODIMENT

10 A linear cross section of an all fiber optical filter of the present invention is illustrated in FIG. 5. The all fiber optical filter 32 has a core 34, an inner cladding 36, an outer cladding 38, and a filter length 40. A cross-section of the all fiber optical filter 32 showing the core 34, the inner cladding 36, and the outer cladding 38 is illustrated in FIG. 6. The core 34 has a core diameter. The inner cladding 36 has an inner cladding  
15 thickness. The outer cladding 38 has an outside diameter. Indexes of refraction for the core 34, the inner cladding 36, and the outer cladding 38 are referred to as a core index of refraction, an inner index of refraction, and an outer index of refraction, respectively. The core index of refraction is preferably greater than the outer index of refraction. The outer index of refraction is preferably greater than the inner index of refraction. By an  
20 appropriate selection of the core index of refraction, the inner index of refraction, and the outer index of refraction as well as selecting the core diameter and the inner cladding thickness, optical energy from an optical signal within a wavelength range is transferred from the core 34 to the outer cladding 38 by evanescent coupling.

The core 34 of the all fiber optical filter 32 is a single mode waveguide. A  
25 convention used when discussing optical waveguides is to refer to an effective index of refraction, which is defined as a waveguide propagation constant  $\beta$  divided by a free space wave number  $k_0$ . The effective index of refraction is both wavelength dependent and mode dependent. A core effective index of refraction for the core 34 has a value between the inner index of refraction and the core index of refraction. Reducing the core diameter  
30 reduces the core effective index of refraction provided that the single mode continues to propagate. The outer cladding 38 is a multimode waveguide. The outer cladding is

sufficiently large that an outer effective index of refraction for a first mode is equal to the outer index of refraction. The inner cladding 36 forms a barrier between the core 34 and the outer cladding 38. Optical energy will transfer from the core 34 to the cladding 38 by evanescent coupling if the core effective index of refraction is near to the outer index of refraction and the barrier is sufficiently narrow. Since the core effective index of refraction depends upon the core diameter, the core diameter determines a wavelength range that could couple from the core 34 to the outer cladding 38.

The core diameter, the core effective index of refraction, and the outer index of refraction determine a peak attenuation wavelength and a wavelength band about the peak attenuation wavelength that couples from the core 34 to the outer cladding 38. Optical energy that couples from the core 34 to the outer cladding 38 and is propagating in the first mode can couple back to the core 34. Accordingly, the outer diameter of the outer cladding and the filter length 40 adjust the peak attenuation wavelength and the wavelength band about the peak wavelength. Depending upon a variation of the core effective index of refraction with wavelength, other peak attenuation wavelengths and wavelength bands could couple from the core 34 to the outer cladding 38.

The all fiber optical filter 32 and additional structure is illustrated in FIG. 7. The additional structure includes an input length 42, an output length 44, a first transition 46, and a second transition 48. The input length 42 connects to the first transition 46, which connects to the all fiber optical filter 32. The all fiber optical filter 32 connects to the second transition 48, which connects to the output length 44. The core 34, the inner cladding 36, and the outer cladding 38 of the all fiber optical filter 32 extend through the input length 42, the first transition 46, the second transition 48, and the output length 44. The thickness of the inner cladding 36, within the input length 42 and the output length 44, is greater than an evanescent coupling thickness that allows evanescent coupling between the core 34 and the outer cladding 38 within the input length 42 and the output length 44. The input length 42 and the output length 44 are coupled to an optical fiber system by appropriate means available for coupling optical fiber components.

An exemplary configuration including an EDFA and a cascaded series of all fiber optical filters used to flatten the EDFA gain over wavelength ranges of 1529 nm to 1562 nm and 1580 nm to 1620 nm is illustrated in FIG. 8A. The EDFA 52 is coupled to a first

all fiber optical filter 54. The first all fiber optical filter 54 is coupled to a second all fiber optical filter 56. An input optical signal 58 is provided to the EDFA 52, which amplifies the input optical signal 58 and provides an amplified optical signal. The amplified optical signal is then provided to the first all fiber optical filter 54, which filters the amplified optical signal and provides a first filtered optical signal. The first filtered optical signal is then provided to the second all fiber optical filter 56, which filters the first filtered optical signal and provides an output optical signal 60.

Other configurations for the EDFA 52, first all fiber optical filter 54, and the second all fiber optical filter 56 are illustrated in FIGS. 8B and 8C. In FIG. 8B, the first all fiber optical filter 54 is coupled to the EDFA 52, which is coupled to the second all fiber optical filter 56. In FIG. 8C, the first all fiber optical filter 54 is coupled to the second all fiber optical filter, which is coupled to the EDFA 52.

In the preferred embodiment of the present invention, intended to operate in the wavelength ranges of 1529 nm to 1562 nm and 1580 nm to 1620 nm, the core 34, the inner cladding 36, and the outer cladding 38 are silica glasses. The indexes of refraction are preferably 1.467 for the core index of refraction, 1.411 for the inner index of refraction, and 1.424 for the outer index of refraction. The core diameter is preferably within the range and including 3  $\mu\text{m}$  and 6  $\mu\text{m}$ . An outer diameter for the inner cladding 36 is preferably within the range and including 12  $\mu\text{m}$  and 30  $\mu\text{m}$ . The outside diameter of the outer cladding 38 is preferably within the range and including 50  $\mu\text{m}$  and 85  $\mu\text{m}$ . The filter length 40 is preferably within the range and including 10 mm and 20 mm. Specific dimensions for the preferred embodiment are a result of a forming process, which preferably uses an optical spectrum response for the all fiber optical filter 32 as a critical parameter.

The preferred embodiment for the all fiber optical filter 32 is formed by identifying a preferred peak EDFA gain response and a preferred wavelength band about the preferred peak gain response that is to be flattened. An inverse of the gain response for the preferred wavelength band becomes a preferred target response for the all fiber optical filter 32 such that the all fiber optical filter 32 provides a preferred attenuation response that is near to the preferred target response after the forming process.

Referring to FIG. 8A, the EDFA 52 provides the amplified optical signal, which is used to determine the first peak EDFA gain response and the first wavelength band. For a test EDFA used in testing an all fiber optical filter of the present invention, the preferred peak EDFA gain response was found to be at 1533 nm with a preferred relative gain response of 6.0 dB. The relative gain response is defined as the difference between a specific gain response for a specific wavelength and a minimum gain response for the wavelength range. The preferred target response about 1533 nm was used in the forming process so that after the forming process, the all fiber optical filter 32 provided the preferred attenuation curve.

An alternative embodiment is formed by identifying an alternate target response for an alternate peak EDFA gain response and an alternate wavelength band about the alternate peak EDFA gain response. For the test EDFA, the alternate peak wavelength was found to be at 1552 nm with an alternate relative gain response of 3.83 dB.

Referring to FIG. 8A, tests were performed in which the EDFA 52 was the test EDFA, the first all fiber optical filter 54 was the preferred embodiment of the all fiber optical filter described above and having the preferred attenuation response, and the second all fiber optical filter 56 was the alternative embodiment of the all fiber optical filter described above and having an alternate attenuation response. Test results using this configuration for the wavelength range from 1529 nm to 1562 nm are illustrated in FIG. 9A. The EDFA gain response is shown as the curve A. The first target response is the inverse of the EDFA gain response from 1529 nm to 1540 nm. The second target response is the inverse of the EDFA gain response from 1540 nm to 1562 nm. The output optical signal 60 is shown as the curve B, which shows a substantially flat attenuated EDFA gain curve over the wavelength range from 1529 nm to 1562 nm.

Test results using this configuration for the wavelength range from 1580 nm to 1620 are illustrated in FIG. 9B. The EDFA gain response is shown as the curve C. The output optical signal 60 is shown as the curve D, which shows a substantially flat attenuated gain curve over the wavelength range from 1580 nm to 1620 nm.

An alternative embodiment comprising the EDFA 52 and a single all fiber optical filter is illustrated in FIG. 10. Depending upon the gain response of the EDFA 52, the single all fiber optical filter 62 will suffice to flatten the gain response of the EDFA 52.

The EDFA 52 is coupled to the single all fiber optical filter 62. The input optical signal 58 is provided to the EDFA 52, which amplifies the input optical signal 58 and provides an amplified optical signal. The amplified optical signal is then provided to the single all fiber optical filter 62, which filters the amplified optical signal and provides the output optical signal 60.

A WDM system with EDFA gain flattening including one or more all fiber optical filters according to the present invention is illustrated in FIG. 11. The WDM system 66 includes a transmission system 11, which includes a series of transmitters 12, 14, and 16 each coupled to a multiplexer 18. The multiplexer 18 provides an output, which is coupled to an optical fiber 20. Over long distances EDFAs 22 and the one or more all fiber optical filters 68 are included along the optical fiber 20. The optical fiber 20 is then also coupled to a receiving system 23, which includes a demultiplexer 24 and a series of receivers 26, 28, and 30. The optical fiber 20 is coupled to an input of the demultiplexer 24 of the receiving system 23. Outputs of the demultiplexer 24 are coupled to the series of receivers 26, 28, and 30.

In the WDM system 66, a first transmitter 12 transmits a light signal at a first wavelength ( $\lambda_1$ ), a second transmitter 14 transmits a light signal at a second wavelength ( $\lambda_2$ ), and so forth until an nth transmitter 16 transmits a light signal at an nth wavelength ( $\lambda_n$ ). The light signals are combined by the multiplexer 18, which then transmits the light signals along the optical fiber 20. Over distance the power of the light signals decrease due to attenuation. The light signals are amplified approximately every 50 - 100 km by the EDFAs 22. The one or more all fiber optical filters 68 flatten the EDFA gain for the light signals, as discussed above. When the light signals reach their destination they are separated by the demultiplexer 24. The light signals are then received by the receivers 26, 28, and 30.

A first apparatus for manufacturing the all fiber optical filter of the present invention is illustrated in FIG. 12. The first apparatus 70 includes a heating source 72, a first clamp 74, a second clamp 76, a first stepper motor 78, a second stepper motor 79, a first drive means 80, and a second drive means 81. The first clamp 74 is placed to one side of the heating source 72. The second clamp 76 is placed adjacent to the heating source 72 on the side opposite to the first clamp 74. The first clamp 74 is connected to the

first stepper motor 78 by the first drive means 80. The second clamp 76 is connected to the second stepper motor 79 by the second drive means 81.

5 A first method of manufacture uses the first apparatus 70. An initial length of optical fiber 82 is held between the first clamp 74 and the second clamp 76. The heating source 72 heats the optical fiber 82 to within an allowed temperature range. The first stepper motor 78 actuates the first drive means 80. The second stepper motor 79 actuates the second drive means 81. Consequently, the first clamp 74 and the second clamp 76 are further separated. This further separation stretches the optical fiber 82. When a predetermined stretch distance has been reached the first and second stepper motor 78 and 10 79 are stopped, which stops the first and second clamp 74 and 76. Finally, the heating source 72 is removed, the heating source 72 is turned off, or the optical fiber 82 is removed from the heating source 72. This results in an all fiber optical filter, according to the present invention, having a predetermined filter length.

A second and preferred apparatus for manufacturing the all fiber optical filter of the 15 present invention is illustrated in FIG. 13. The second apparatus 84 includes the first apparatus 70, a process control unit 86, a light source 88, and an optical spectrum analyzer 90. The light source 88 is located at one end of the optical fiber 82. The optical spectrum analyzer 90 is located at the end of the optical fiber 82 opposite to the light source 88. The process control unit 86 controls and monitors the heating source 72 through a first 20 control link 92. The process control unit 86 controls the first stepper motor 78 through a second control link 94. The process control unit 86 controls the second stepper motor 79 through a third control link 95. The process control unit 86 controls the light source 88 through a fourth control link 96. The process control unit 86 controls and monitors the optical spectrum analyzer 90 through a fifth control link 98.

25 A second and preferred method of manufacture uses the second apparatus 84. The initial length of optical fiber 82 is held between the first clamp 74 and the second clamp 76. The process control unit 86 signals and monitors the heating source 72. The heating source 72 heats the optical fiber to within the allowed temperature range. The process control unit 86 turns on the light source 88. The light source 88 couples light to the 30 optical fiber 82. Preferably, the light source 88 is a white light source. The optical fiber 82 transmits the light to the end of the optical fiber 82 opposite the light source 88. The

light exits the optical fiber 82. The process control unit turns on the optical spectrum analyzer 90. The optical spectrum analyzer 90 detects the light that exits from the optical fiber 82. The process control unit 86 signals the first and second stepper motors 78 and 79. The first and second stepper motors 78 and 79 further separate the first and second clamps 74 and 76. This further separation stretches the optical fiber 82. As the optical fiber 82 is stretched, the light signal at the end of the optical fiber adjacent to the optical spectrum is monitored for a predetermined optical spectrum response that is based on the target response, as described above. When the optical spectrum analyzer 90 detects the predetermined optical spectrum response, the process control unit 86 stops the first and second stepper motors 78 and 79, thereby stopping the first and second clamp 74 and 76. Finally, the process control unit signals the heating source 72 to stop heating. This results in an all fiber optical filter, according to the present invention, having a desired attenuation response.

Preferably, the optical fiber 82 used to form the all fiber optical filter 32 of the present invention has a core with an initial diameter of 8.3  $\mu\text{m}$ , an inner cladding with an initial outside diameter of 45  $\mu\text{m}$ , and an outer cladding with an initial outside diameter of 125  $\mu\text{m}$ . Preferably, a length of 6 mm is heated by the heating source 72 to a temperature within the range between 900  $^{\circ}\text{C}$  and 1100  $^{\circ}\text{C}$ . The optical fiber 82 is stretched to a length of about 15 mm. Preferably, the specific stretch length and other dimensions of the all fiber optical filter are determined by the predetermined optical spectrum response.

It will be readily apparent to one skilled in the art that other various modifications may be made to the preferred embodiment without departing from the spirit and scope of the invention as defined by the appended claims. Specifically, the all fiber optical filter of the present invention could be used to flatten the gain of other rare earth doped fiber amplifiers or the all fiber optical filter of the present invention could be used to filter or attenuate any optical signal.



## CLAIMS

We claim:

- 1 1. An all fiber optical filter formed from stretching an optical fiber and  
2 comprising a fiber optic core, an inner cladding formed concentrically about the fiber optic  
3 core, and an outer cladding formed concentrically about the inner cladding, wherein an  
4 outer index of refraction of the outer cladding is less than a core index of refraction of the  
5 fiber optic core and further wherein the outer index of refraction is greater than an inner  
6 index of refraction of the inner cladding.
- 1 2. The all fiber optical filter as claimed in claim 1 wherein the optical fiber is  
2 stretched until evanescent coupling is achieved between the fiber optic core and the outer  
3 cladding.
- 1 3. The all fiber optical filter as claimed in claim 2 wherein the all fiber optical  
2 filter is configured to receive an optical signal, including a gain, from a fiber amplifier.
- 1 4. The all fiber optical filter as claimed in claim 3 wherein the optical signal is  
2 filtered by the evanescent coupling between the fiber optic core and the outer cladding to  
3 flatten the gain.
- 1 5. The all fiber optical filter as claimed in claim 1 wherein the optical fiber is  
2 stretched until a filter optical response is approximately equal to a target optical spectrum  
3 response.
- 1 6. The all fiber optical filter as claimed in claim 5 wherein the target optical  
2 spectrum response is an inverse of a portion of an amplifier gain spectrum.
- 1 7. An all fiber optical filter formed by stretching an optical fiber and  
2 comprising:

- 3           a.           a single mode fiber optic core having a core index of refraction;  
4           b.           an inner cladding formed concentrically about the single mode fiber  
5           optic core, the inner cladding having an inner index of refraction, the inner  
6           index of refraction being less than the core index of refraction; and  
7           c.           an outer cladding formed concentrically about the inner cladding, the  
8           outer cladding having an outer index of refraction, the outer index of  
9           refraction being less than the core index of refraction, the outer index being  
10          greater than the inner index of refraction;  
11          wherein the optical fiber is stretched until a filter optical response is approximately equal to  
12          a target optical spectrum response.

1          8.           The all fiber optical filter as claimed in claim 7 wherein the target optical  
2          spectrum response is an inverse of a portion of an amplifier gain spectrum.

- 1          9.           An optical filter comprising:  
2           a.           a fiber optic core having a first diameter, a filter length, and a first  
3           index of refraction;  
4           b.           an inner cladding formed concentrically about the fiber optic core,  
5           the inner cladding having a second index of refraction and a first thickness,  
6           wherein the second index of refraction is less than the first index of  
7           refraction; and  
8           c.           an outer cladding formed concentrically about the inner cladding, the  
9           outer cladding having a third index of refraction, wherein the third index of  
10          refraction is greater than the second index of refraction and less than the first  
11          index of refraction, and further wherein the first diameter and the first  
12          thickness are of dimensions to promote evanescent coupling between the  
13          fiber optic core and the outer cladding.

1          10.          The optical filter as claimed in claim 9 wherein the optical filter is  
2          configured to receive an optical signal, including a gain, from a fiber amplifier.

1 11. The optical filter as claimed in claim 10 wherein the optical signal is filtered  
2 by the evanescent coupling between the fiber optic core and the outer cladding to flatten  
3 the gain.

1 12. The optical filter as claimed in claim 11 wherein the fiber optic core further  
2 includes an input length with a second diameter and an output length with a third diameter,  
3 wherein the input length is coupled to the filter length by a first transition length and the  
4 output length is coupled to the filter length by a second transition length, and further  
5 wherein the second diameter and the third diameter each are greater the first diameter.

1 13. The optical filter as claimed in claim 12 wherein the inner cladding includes  
2 a second thickness formed about the input length of the fiber optic core and a third  
3 thickness formed about the output length of the fiber optic core, the inner cladding having  
4 a first smooth variation thickness from the first thickness to the second thickness and a  
5 second smooth variation thickness from the first thickness to the third thickness, wherein  
6 the second thickness and the third thickness are each greater than the first thickness.

1 14. The optical filter as claimed in claim 13 wherein the outer cladding includes  
2 an input outer cladding formed about the second thickness and the first smooth variation  
3 thickness.

1 15. The optical filter as claimed in claim 14 wherein the outer cladding includes  
2 an output outer cladding formed about the third thickness and the second smooth variation  
3 thickness.

1 16. An all fiber optical filter for flattening gain of an amplified optical signal  
2 provided from a fiber amplifier comprising:

3 a. a fiber optic core having an input length, a filter length, an output  
4 length and a first index of refraction, wherein the input length is separated  
5 from the filter length by a first transition length and the filter length is  
6 separated from the output length by a second transition length and further

- 7                    wherein the first transition length has a decreasing diameter from the input  
8                    length to the filter length and the second transition length has an increasing  
9                    diameter form the filter length to the output length;
- 10                  b.                    an inner cladding formed concentrically about the fiber optic core,  
11                    the inner cladding having a second index of refraction and an input thickness  
12                    formed about the input length of the fiber optic core and a filter thickness  
13                    formed about the filter length of the fiber optic core and a first smooth  
14                    variation thickness from the input thickness to the filter thickness, the inner  
15                    cladding having an output thickness formed about the output length of the  
16                    fiber optic core, the inner cladding having a second smooth variation  
17                    thickness form the filter thickness to the output thickness; and
- 18                  c.                    an outer cladding formed concentrically about the inner cladding, the  
19                    outer cladding having a third index of refraction which is less than the first  
20                    index of refraction and greater than the second index of refraction.

1                  17.                  The all fiber optical filter as claimed in claim 16 wherein a core diameter of  
2                    the fiber optic core and the filter thickness are of dimensions to promote evanescent  
3                    coupling between the fiber optic core and the outer cladding.

1                  18.                  The all fiber optical filter as claimed in claim 17 wherein the optical filter is  
2                    configured to receive an optical signal, including a gain, from a fiber amplifier.

1                  19.                  The all fiber optical filter as claimed in claim 18 wherein the optical filter is  
2                    filtered by the evanescent coupling between the fiber optic core and the outer cladding to  
3                    flatten the gain.

1                  20.                  A fiber optic communication system for transmitting an optical signal  
2                    comprising:  
3                    a.                    a transmission system configured to receive and transmit the optical  
4                    signal;

- 5           b.           a first length of optical fiber coupled to the transmission system for  
6           carrying the optical signal;
- 7           c.           an amplifier coupled to the first length of optical fiber for amplifying  
8           the optical signal thereby forming an amplified signal having a gain;
- 9           d.           an optical filter coupled to the amplifier for filtering the amplified  
10          signal and flattening the gain, thereby forming a filtered signal, the optical  
11          filter including:
- 12          i.          a fiber optic core having a first diameter, a filter length, a first index  
13          of refraction, a first end for receiving the amplified signal, and a  
14          second end for transmitting the filtered signal;
- 15          ii.         an inner cladding formed concentrically about the fiber optic core,  
16          the inner cladding having a second index of refraction and a first  
17          thickness, wherein the second index of refraction is less than the first  
18          index of refraction; and
- 19          iii.        an outer cladding formed concentrically about the inner cladding, the  
20          outer cladding having a third index of refraction, wherein the third  
21          index of refraction is greater than the second index of refraction and  
22          the third index of refraction is less than the first index of refraction,  
23          wherein the first diameter and the first thickness are of dimensions to  
24          promote evanescent coupling between the fiber optic core and the  
25          outer cladding to flatten the gain of the optical signal;
- 26          e.          a second length of optical fiber coupled to the optical filter for  
27          carrying the filtered signal; and
- 28          f.          a receiving system coupled to the second length of optical fiber to  
29          receive the filtered signal.

- 1    21.           The fiber optic communication system as claimed in claim 20 wherein the  
2    transmission system includes a multiplexer and a plurality of transmitters coupled to the  
3    multiplexer for transmitting the optical signal.

- 1 22. The fiber optic communication system as claimed in claim 21 wherein the  
2 receiving system includes a demultiplexer and a plurality of receivers coupled to the  
3 demultiplexer for receiving the filtered signal.
- 1 23. A fiber optic communication system for transmitting an optical signal  
2 comprising:
- 3 a. a transmission system configured to receive and transmit the optical  
4 signal;
  - 5 b. a first length of optical fiber coupled to the transmission system for  
6 carrying the optical signal;
  - 7 c. an optical filter coupled to the first length of optical fiber for filtering  
8 the optical signal, thereby forming a filtered signal, the optical filter  
9 including:
    - 10 i. a fiber optic core having a first diameter, a filter length, a first index  
11 of refraction, a first end for receiving the amplified signal, and a  
12 second end for transmitting the filtered signal;
    - 13 ii. an inner cladding formed concentrically about the fiber optic core,  
14 the inner cladding having a second index of refraction and a first  
15 thickness, wherein the second index of refraction is less than the first  
16 index of refraction; and
    - 17 iii. an outer cladding formed concentrically about the inner cladding, the  
18 outer cladding having a third index of refraction, wherein the third  
19 index of refraction is greater than the second index of refraction and  
20 the third index of refraction is less than the first index of refraction,  
21 wherein the first diameter and the first thickness are of dimensions to  
22 promote evanescent coupling between the fiber optic core and the  
23 outer cladding to filter the optical signal;
  - 24 d. an amplifier coupled to the optical filter for amplifying the filtered  
25 signal thereby forming an amplified signal having a flattened gain;
  - 26 e. a second length of optical fiber coupled to the amplifier for carrying  
27 the amplified signal having the flattened gain; and

28 f. a receiving system coupled to the second length of optical fiber to  
29 receive the amplified signal having the flattened gain.

1 24. The fiber optic communication system as claimed in claim 23 wherein the  
2 transmission system includes a multiplexer and a plurality of transmitters coupled to the  
3 multiplexer for transmitting the optical signal.

1 25. The fiber optic communication system as claimed in claim 24 wherein the  
2 receiving system includes a demultiplexer and a plurality of receivers coupled to the  
3 demultiplexer for receiving the filtered signal.

1 26. A method of manufacturing an all fiber optical filter, which begins with an  
2 optical fiber having a core, inner cladding, and outer cladding, comprising:

- 3 a. holding the optical fiber between a first clamp and a second clamp;
- 4 b. heating a length of the optical fiber between the first clamp and the  
5 second clamp; and
- 6 c. stretching the optical fiber by further separating the first clamp and  
7 the second clamp until a predetermined characteristic is achieved.

1 27. The method as claimed in claim 26 wherein the predetermined characteristic  
2 is a stretch length of the optical fiber.

1 28. The method as claimed in claim 27 wherein the step of heating includes  
2 heating the length of optical fiber to a temperature within the range of 900 °C to 1100 °C.

1 29. The method as claimed in claim 28 wherein the step of stretching is  
2 completed by using a first stepper motor that controls the movement of the first clamp and  
3 a second stepper motor that controls the movement of the second clamp.

1 30. The method of claim 26 wherein the predetermined characteristic is an  
2 optical spectrum response of the optical fiber.

1 31. The method as claimed in claim 30 wherein the optical spectrum response is  
2 measured using a white light source and an optical spectrum analyzer.

1 32. The method as claimed in claim 31 wherein the predetermined optical  
2 spectrum response is based upon an inverse of a portion of an amplifier gain spectrum such  
3 that upon cooling of the all fiber optical filter, the optical spectrum response will be nearly  
4 equal to the inverse of the portion of the amplifier gain spectrum.

1 33. The method as claimed in claim 32 wherein the temperature is within the  
2 range between and including 900 °C to 1100 °C.



1/10

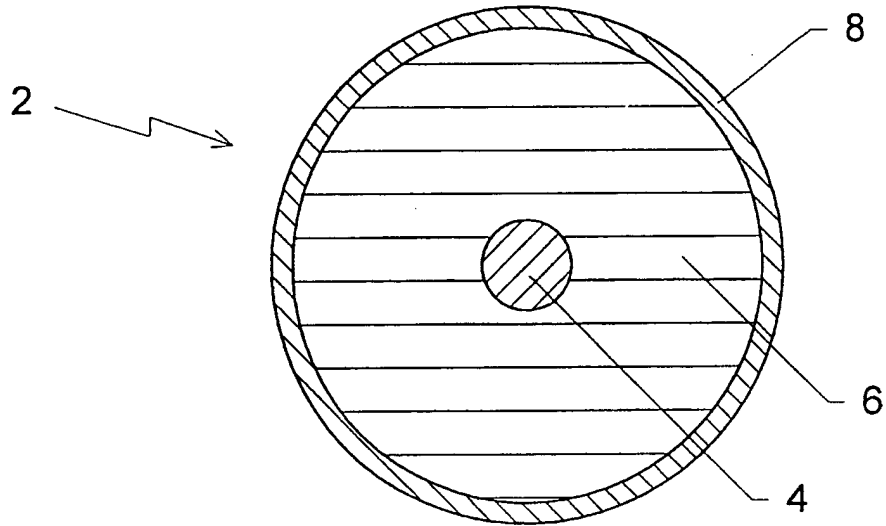


FIG. 1  
(PRIOR ART)

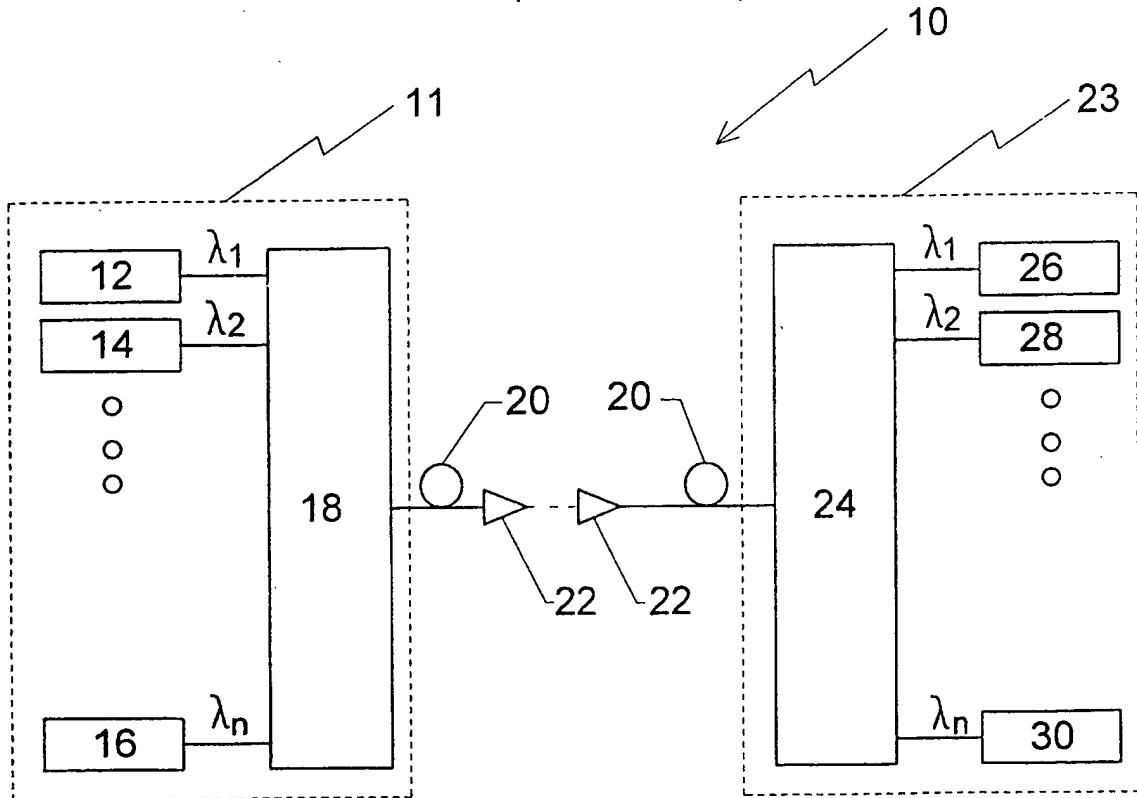


FIG. 2  
(PRIOR ART)

2/10

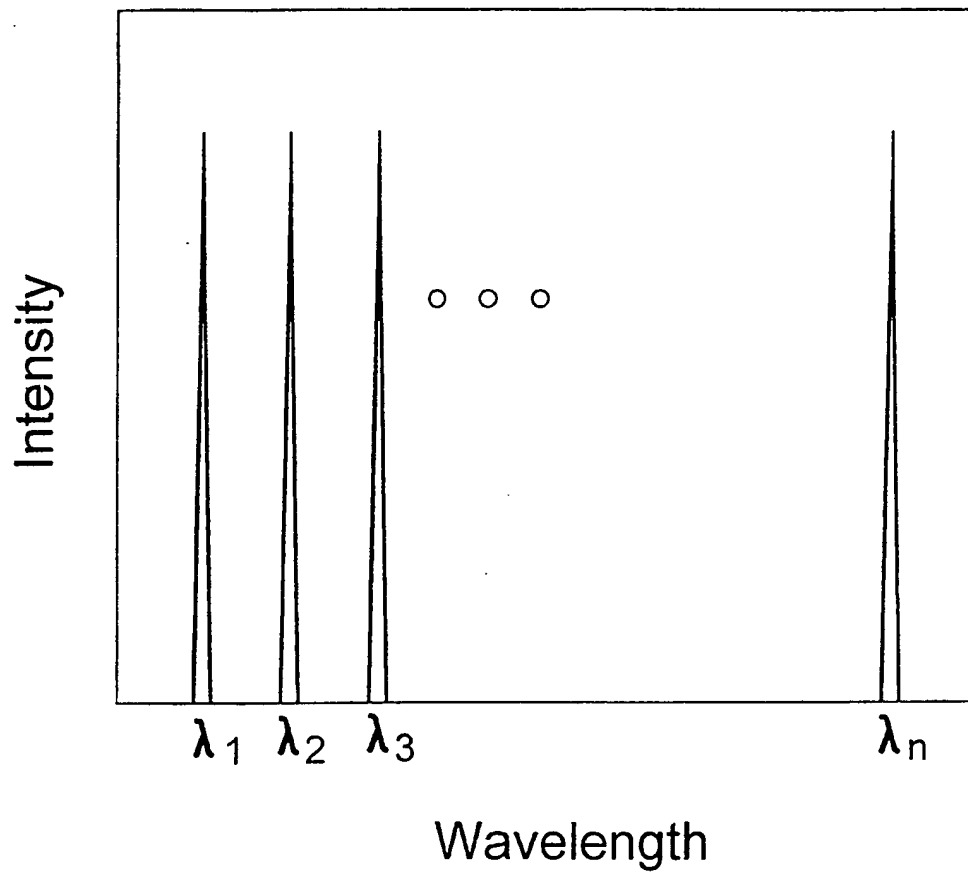
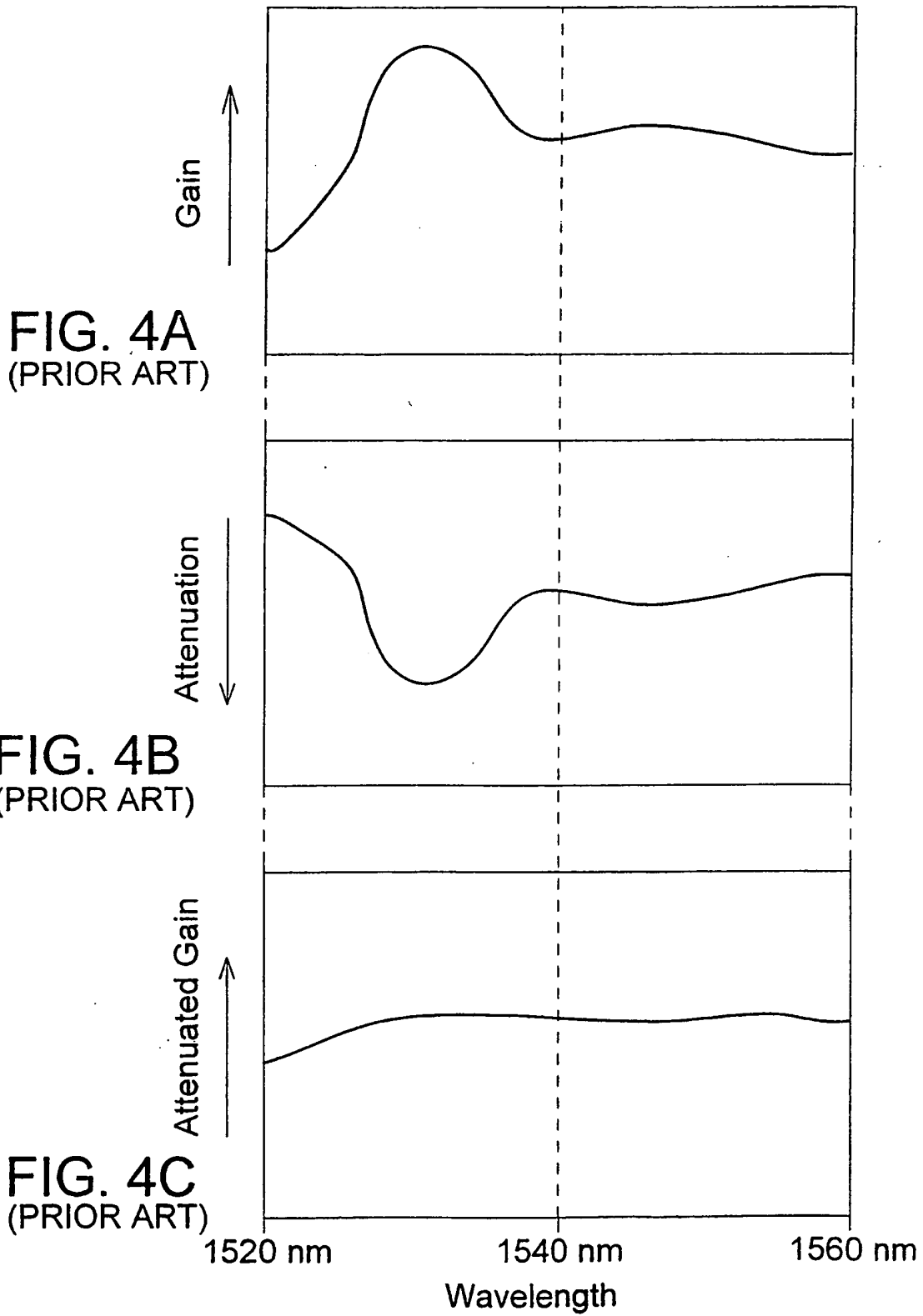


FIG. 3  
(PRIOR ART)

3/10



4/10

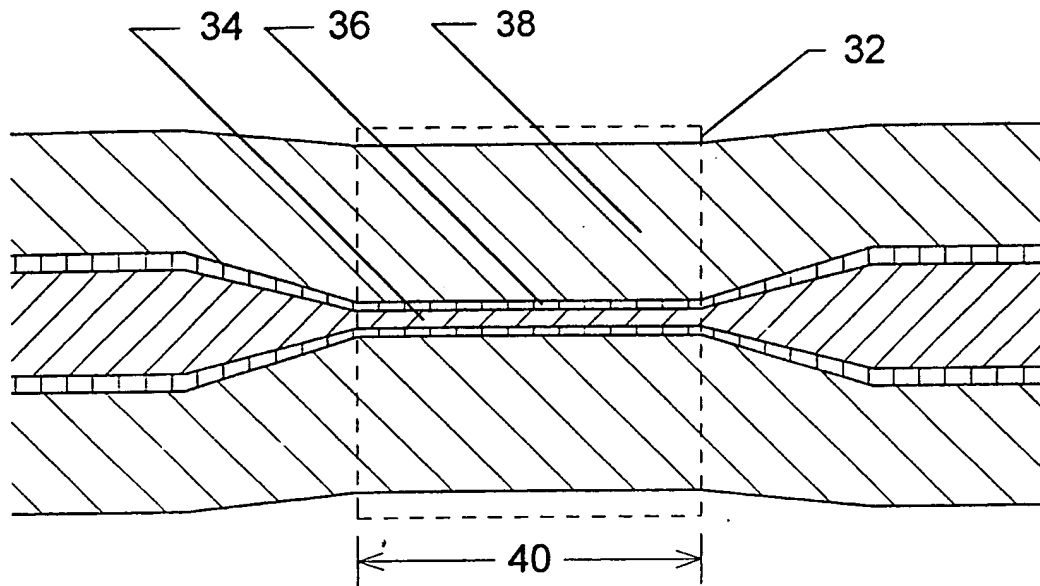


FIG. 5

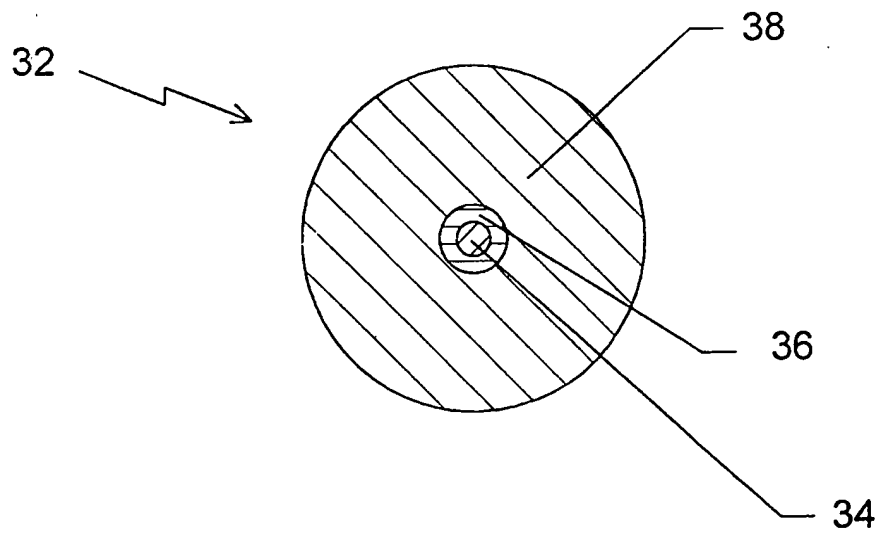


FIG. 6

5/10

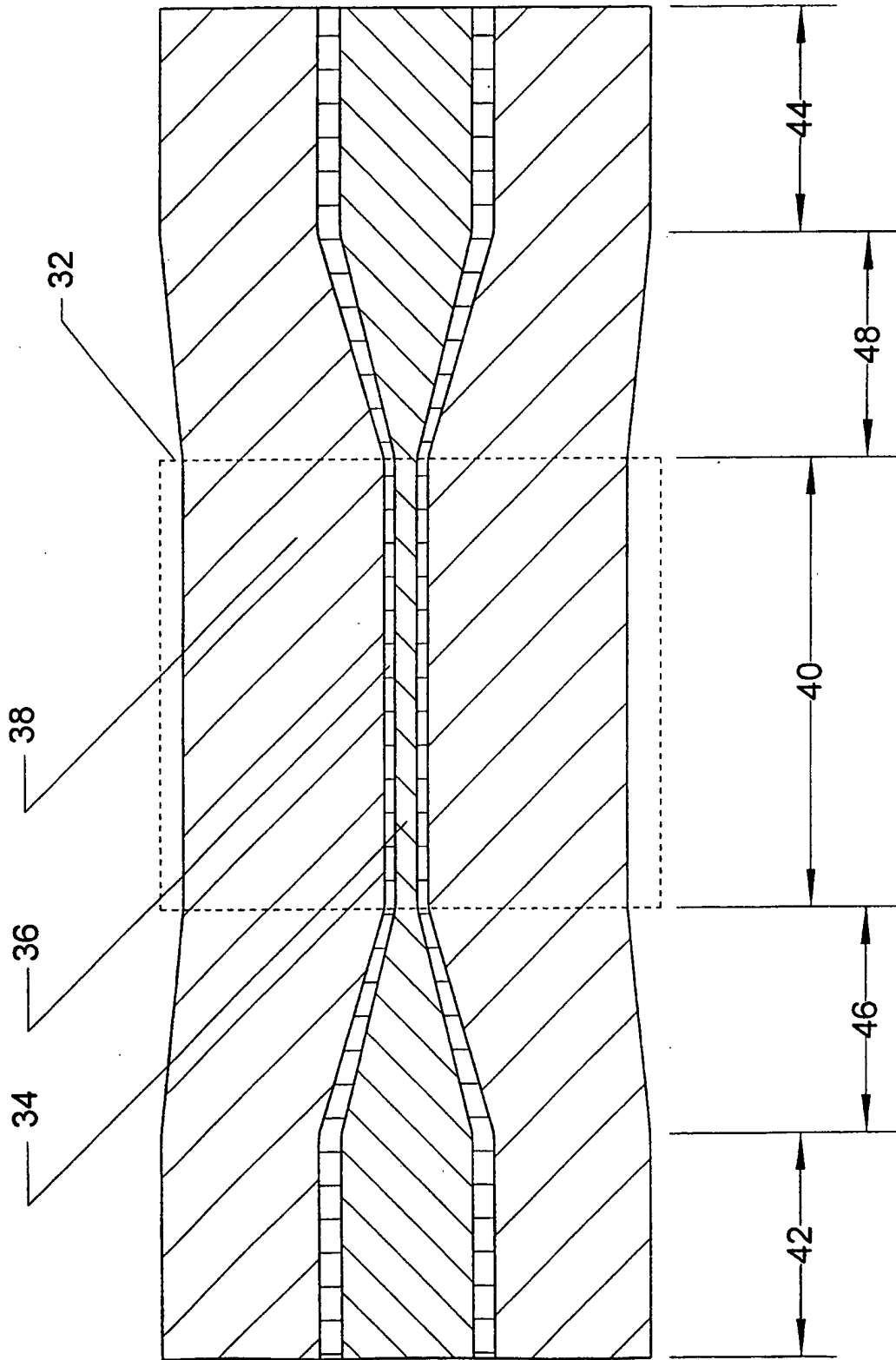


FIG. 7

6/10

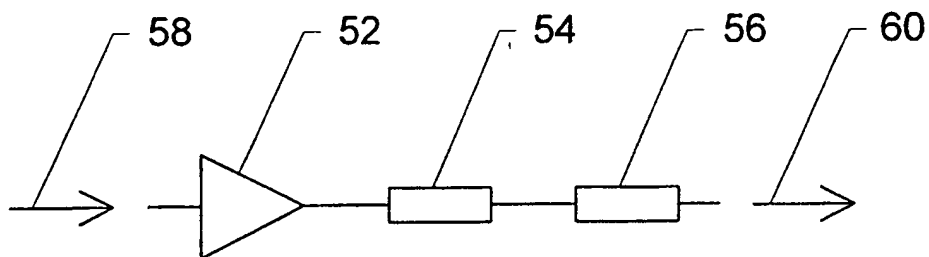


FIG. 8A

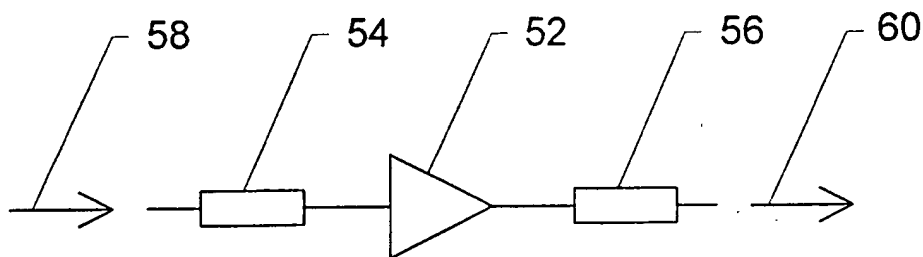


FIG. 8B

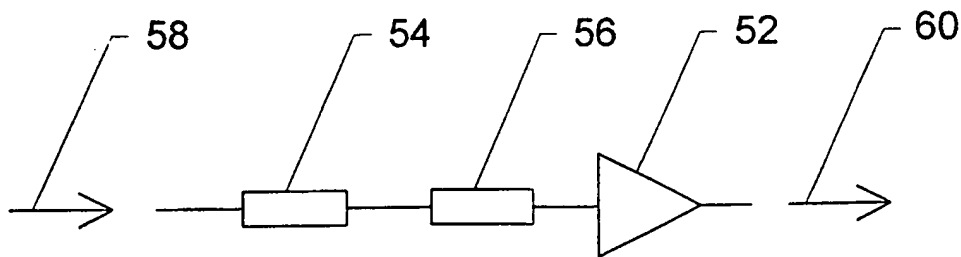


FIG. 8C

7/10

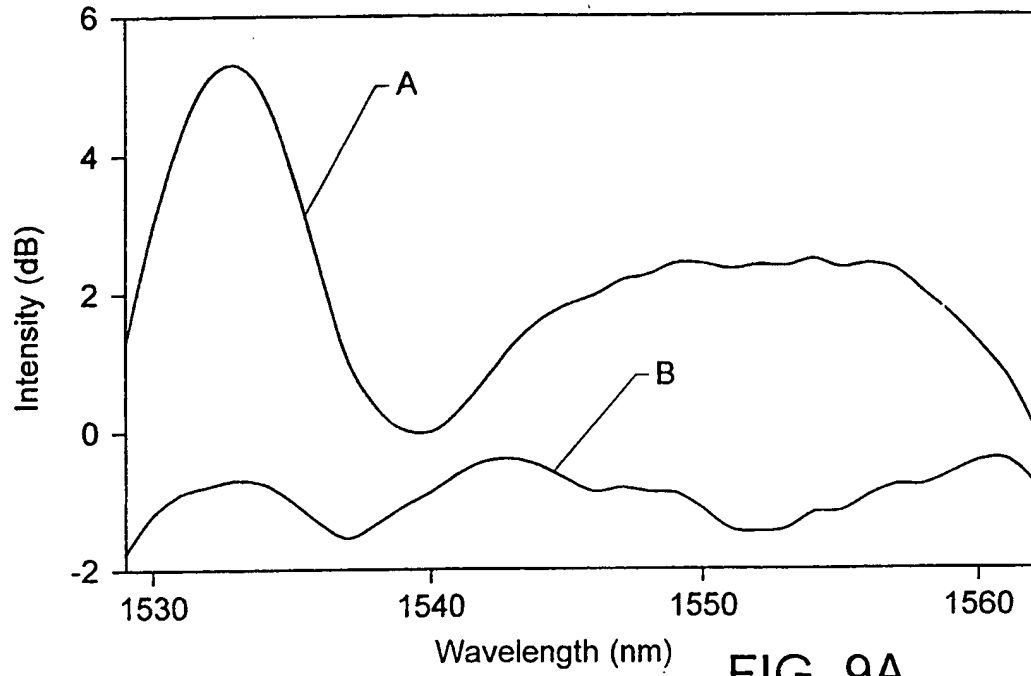


FIG. 9A

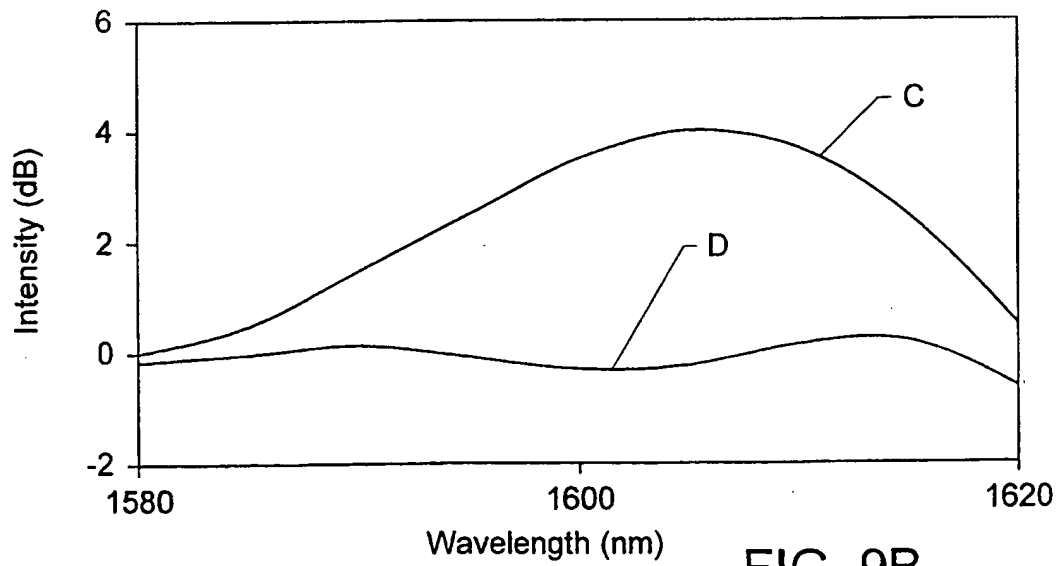


FIG. 9B

8/10

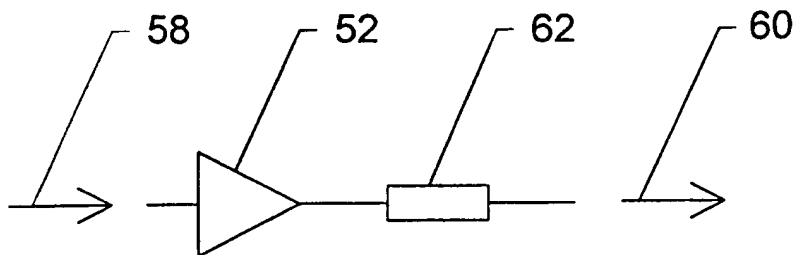


FIG. 10

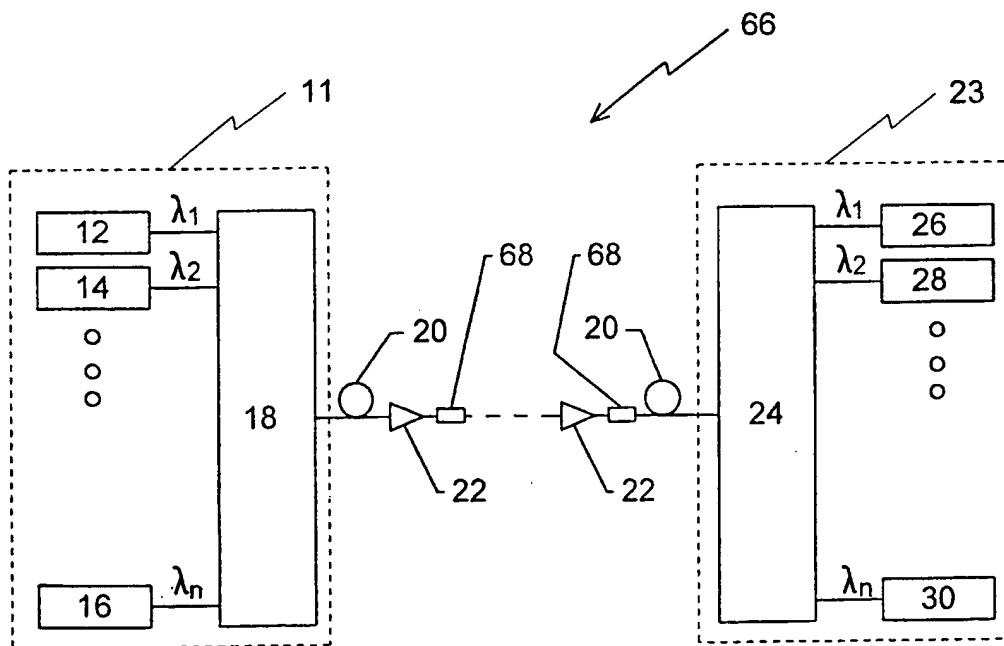


FIG. 11



9/10

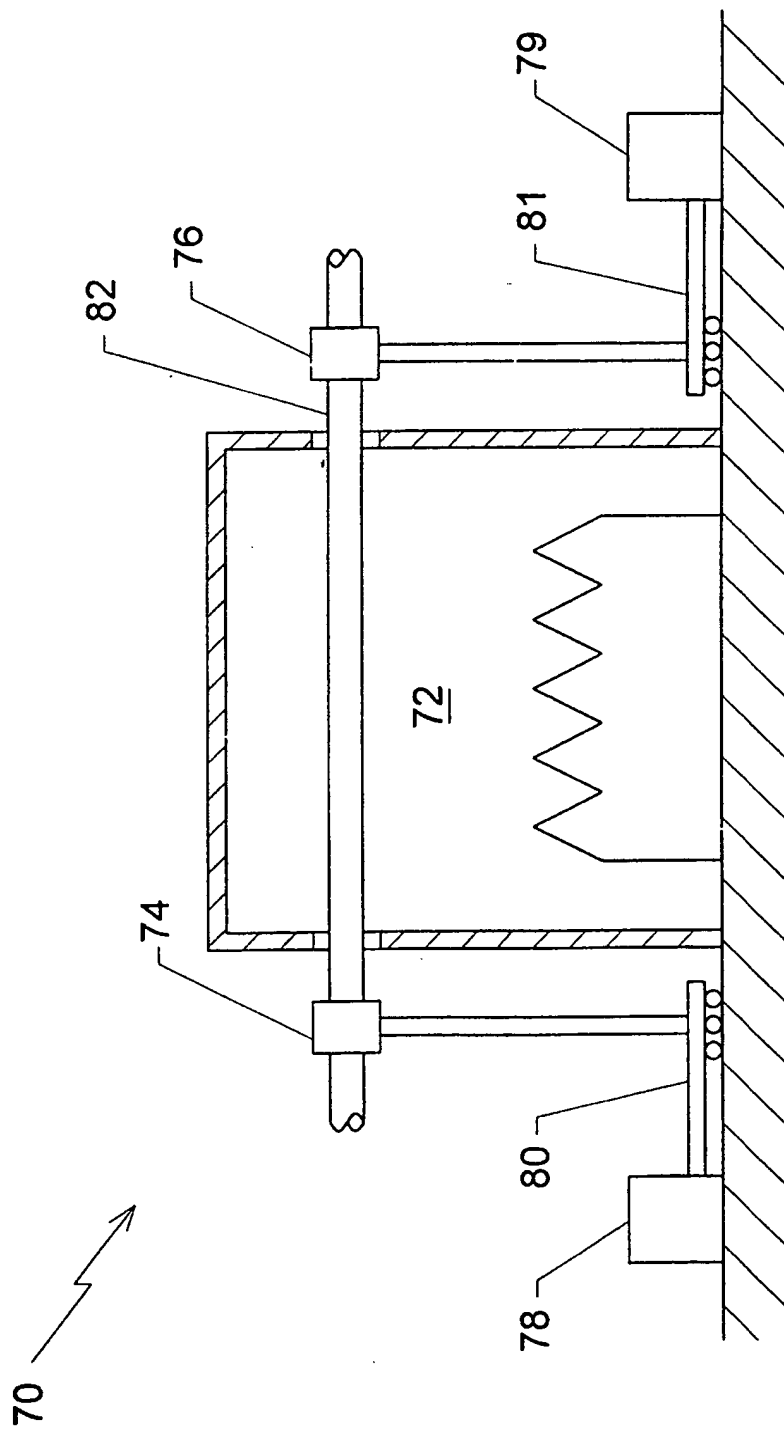


FIG. 12

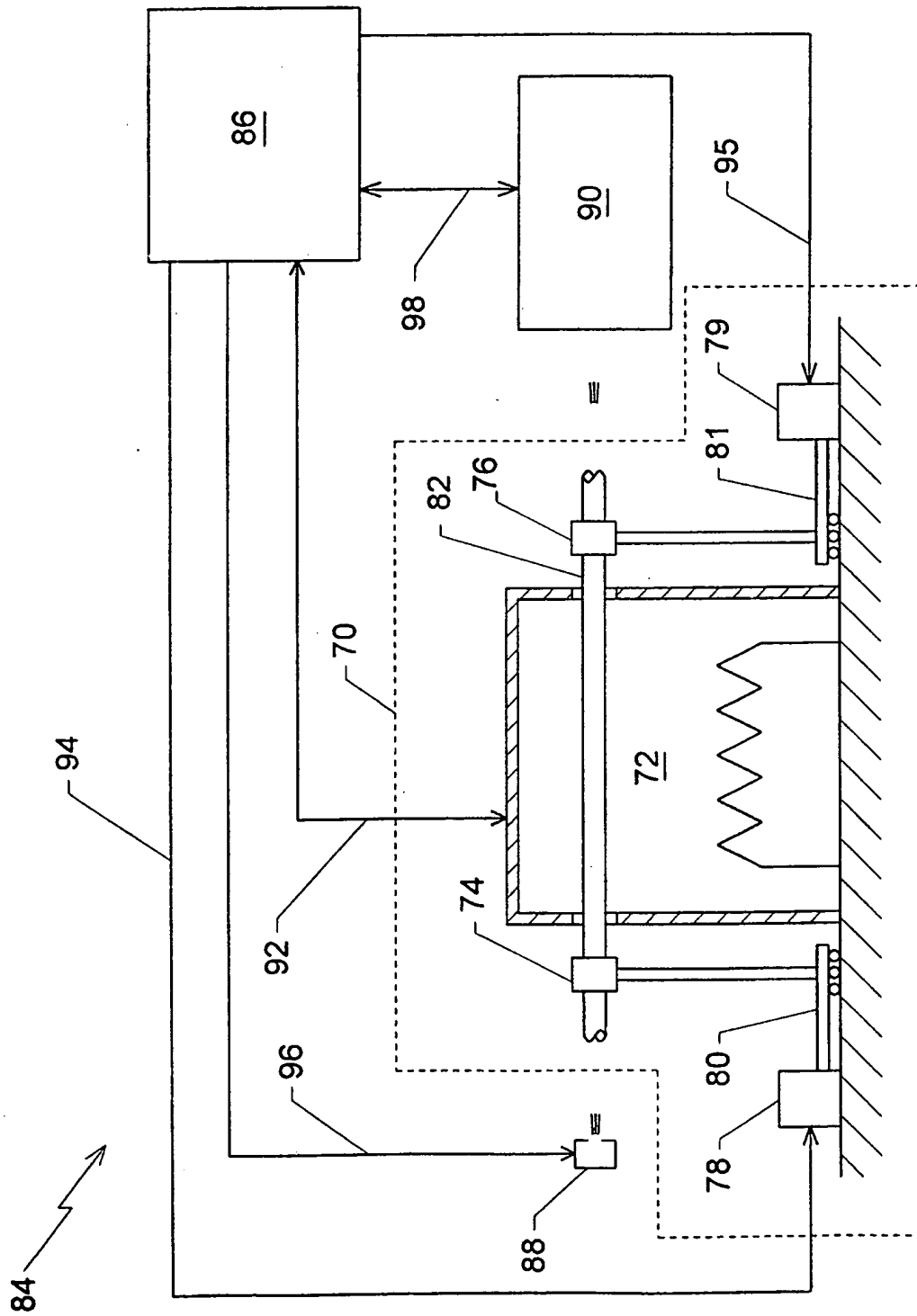


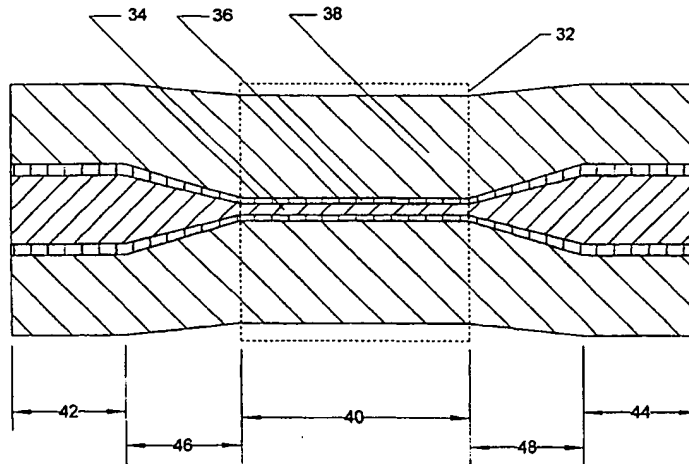
FIG. 13



INTERNATIONAL APPLICATION PUBLISHED UNDER THE PATENT COOPERATION TREATY (PCT)

<p>(51) International Patent Classification <sup>7</sup> : <b>G02B 6/26, 6/02, H01S 3/30</b></p>	<p><b>A3</b></p>	<p>(11) International Publication Number: <b>WO 00/22742</b> (43) International Publication Date: 20 April 2000 (20.04.00)</p>
<p>(21) International Application Number: PCT/US99/22102 (22) International Filing Date: 23 September 1999 (23.09.99)</p> <p>(30) Priority Data: 60/101,853 25 September 1998 (25.09.98) US 09/246,985 9 February 1999 (09.02.99) US</p> <p>(71) Applicant: FIVER LABORATORIES [US/US]; Suite 316, 48521 Warm Springs Blvd., Fremont, CA 94539 (US).</p> <p>(72) Inventors: WU, Weiti; 328 Sandhurst Drive, Milpitas, CA 95035 (US). KO, Yu-Li; 45654 Cheyenne Place, Fremont, CA 94539 (US). CHUNG, Gary; 41366 Charlita Court, Fremont, CA 94539 (US).</p> <p>(74) Agents: HAVERSTOCK, Thomas, B. et al.; Haverstock &amp; Owens LLP, Suite 420, 260 Sheridan Avenue, Palo Alto, CA 94306 (US).</p>	<p>(81) Designated States: AE, AL, AM, AT, AU, AZ, BA, BB, BG, BR, BY, CA, CH, CN, CU, CZ, DE, DK, EE, ES, FI, GB, GD, GE, GH, GM, HR, HU, ID, IL, IN, IS, JP, KE, KG, KP, KR, KZ, LC, LK, LR, LS, LT, LU, LV, MD, MG, MK, MN, MW, MX, NO, NZ, PL, PT, RO, RU, SD, SE, SG, SI, SK, SL, TJ, TM, TR, TT, UA, UG, UZ, VN, YU, ZA, ZW, ARIPO patent (GH, GM, KE, LS, MW, SD, SL, SZ, TZ, UG, ZW), Eurasian patent (AM, AZ, BY, KG, KZ, MD, RU, TJ, TM), European patent (AT, BE, CH, CY, DE, DK, ES, FI, FR, GB, GR, IE, IT, LU, MC, NL, PT, SE), OAPI patent (BF, BJ, CF, CG, CI, CM, GA, GN, GW, ML, MR, NE, SN, TD, TG).</p> <p><b>Published</b> <i>With international search report.</i></p> <p>(88) Date of publication of the international search report: 13 July 2000 (13.07.00)</p>	

(54) Title: ALL FIBER GAIN FLATTENING OPTICAL FILTER



(57) Abstract

An all fiber optical filter (32) is formed by stretching an optical fiber. The all fiber filter includes a core (34), an inner cladding (36), and an outer cladding (38). A core (34) index of refraction is greater than an outer cladding (38) index of refraction, and the outer cladding (38) index of refraction is greater than the inner cladding (36) index of refraction. The filter attenuates optical signals by transferring energy from the core (34) to the outer cladding (38) by evanescent coupling. The filter can be used for gain flattening in a WDM communication system (66) with EDFAs. The filter is manufactured by holding a length of an appropriate optical fiber (82) between two clamps (74, 76), heating the fiber (82) and stretching the fiber (82) until the desired filtering characteristics are achieved.

**FOR THE PURPOSES OF INFORMATION ONLY**

Codes used to identify States party to the PCT on the front pages of pamphlets publishing international applications under the PCT.

AL	Albania	ES	Spain	LS	Lesotho	SI	Slovenia
AM	Armenia	FI	Finland	LT	Lithuania	SK	Slovakia
AT	Austria	FR	France	LU	Luxembourg	SN	Senegal
AU	Australia	GA	Gabon	LV	Latvia	SZ	Swaziland
AZ	Azerbaijan	GB	United Kingdom	MC	Monaco	TD	Chad
BA	Bosnia and Herzegovina	GE	Georgia	MD	Republic of Moldova	TG	Togo
BB	Barbados	GH	Ghana	MG	Madagascar	TJ	Tajikistan
BE	Belgium	GN	Guinea	MK	The former Yugoslav Republic of Macedonia	TM	Turkmenistan
BF	Burkina Faso	GR	Greece	ML	Mali	TR	Turkey
BG	Bulgaria	HU	Hungary	MN	Mongolia	TT	Trinidad and Tobago
BJ	Benin	IE	Ireland	MR	Mauritania	UA	Ukraine
BR	Brazil	IL	Israel	MW	Malawi	UG	Uganda
BY	Belarus	IS	Iceland	MX	Mexico	US	United States of America
CA	Canada	IT	Italy	NE	Niger	UZ	Uzbekistan
CF	Central African Republic	JP	Japan	NL	Netherlands	VN	Viet Nam
CG	Congo	KE	Kenya	NO	Norway	YU	Yugoslavia
CH	Switzerland	KG	Kyrgyzstan	NZ	New Zealand	ZW	Zimbabwe
CI	Côte d'Ivoire	KP	Democratic People's Republic of Korea	PL	Poland		
CM	Cameroon	KR	Republic of Korea	PT	Portugal		
CN	China	KZ	Kazakstan	RO	Romania		
CU	Cuba	LC	Saint Lucia	RU	Russian Federation		
CZ	Czech Republic	LI	Liechtenstein	SD	Sudan		
DE	Germany	LK	Sri Lanka	SE	Sweden		
DK	Denmark	LR	Liberia	SG	Singapore		
EE	Estonia						

INTERNATIONAL SEARCH REPORT

International application No.  
PCT/US99/22102

**A. CLASSIFICATION OF SUBJECT MATTER**

IPC(7) :G02B 6/26, 6/02; H01S 3/30  
US CL :Please See Extra Sheet.

According to International Patent Classification (IPC) or to both national classification and IPC

**B. FIELDS SEARCHED**

Minimum documentation searched (classification system followed by classification symbols)

U.S. : 359/337, 341, 566, 569, 572, 885; 385/30, 37, 127, 128, 131; 257/98; 248/290; 348/342

Documentation searched other than minimum documentation to the extent that such documents are included in the fields searched

Electronic data base consulted during the international search (name of data base and, where practicable, search terms used)

INSPEC, COMP, JAPIO, DERWENT, EPO, USPAT

**C. DOCUMENTS CONSIDERED TO BE RELEVANT**

Category*	Citation of document, with indication, where appropriate, of the relevant passages	Relevant to claim No.
X, P	US 5,892,615 A (GRUBB ET AL) 06 April 1999, FIGURE 1, and COLUMNS 3-5	1-33
Y, P	US 5,857,053 A (KANE) 05 January 1999, FIGURES 2, 4 and COLUMN 2, LINES 15-21	1-33
Y	JP 61,279,805 A (YOKOHAMA ET AL) 10 December 1986, ABSTRACT	1-33

Further documents are listed in the continuation of Box C.  See patent family annex.

* Special categories of cited documents:	*T* later document published after the international filing date or priority date and not in conflict with the application but cited to understand the principle or theory underlying the invention
*A* document defining the general state of the art which is not considered to be of particular relevance	*X* document of particular relevance; the claimed invention cannot be considered novel or cannot be considered to involve an inventive step when the document is taken alone
*E* earlier document published on or after the international filing date	*Y* document of particular relevance; the claimed invention cannot be considered to involve an inventive step when the document is combined with one or more other such documents, such combination being obvious to a person skilled in the art
*L* document which may throw doubts on priority claim(s) or which is cited to establish the publication date of another citation or other special reason (as specified)	*Z* document member of the same patent family
*O* document referring to an oral disclosure, use, exhibition or other means	
*P* document published prior to the international filing date but later than the priority date claimed	

Date of the actual completion of the international search

20 MARCH 2000

Date of mailing of the international search report

26 APR 2000

Name and mailing address of the ISA/US  
Commissioner of Patents and Trademarks  
Box PCT  
Washington, D.C. 20231

Facsimile No. (703) 305-0285

Authorized officer

NELSON MOSKOWITZ

Telephone No. (703) 306-4165

INTERNATIONAL SEARCH REPORT

International application No.  
PCT/US99/22102

**Box I Observations where certain claims were found unsearchable (Continuation of item 1 of first sheet)**

This international report has not been established in respect of certain claims under Article 17(2)(a) for the following reasons:

1.  Claims Nos.:  
because they relate to subject matter not required to be searched by this Authority, namely:
  
2.  Claims Nos.:  
because they relate to parts of the international application that do not comply with the prescribed requirements to such an extent that no meaningful international search can be carried out, specifically:
  
3.  Claims Nos.:  
because they are dependent claims and are not drafted in accordance with the second and third sentences of Rule 6.4(a).

**Box II Observations where unity of invention is lacking (Continuation of item 2 of first sheet)**

This International Searching Authority found multiple inventions in this international application, as follows:

Please See Extra Sheet.

1.  As all required additional search fees were timely paid by the applicant, this international search report covers all searchable claims.
2.  As all searchable claims could be searched without effort justifying an additional fee, this Authority did not invite payment of any additional fee.
3.  As only some of the required additional search fees were timely paid by the applicant, this international search report covers only those claims for which fees were paid, specifically claims Nos.:
  
4.  No required additional search fees were timely paid by the applicant. Consequently, this international search report is restricted to the invention first mentioned in the claims: it is covered by claims Nos.:

Remark on Protest

- The additional search fees were accompanied by the applicant's protest.  
 No protest accompanied the payment of additional search fees.

INTERNATIONAL SEARCH REPORT

International application No.

PCT/US99/22102

A. CLASSIFICATION OF SUBJECT MATTER:

US CL :

359/337, 341, 566, 569, 572, 885; 385/30, 37, 127, 128, 131; 257/98; 248/290; 348/342

BOX II. OBSERVATIONS WHERE UNITY OF INVENTION WAS LACKING

This ISA found multiple inventions as follows:

This application contains the following inventions or groups of inventions which are not so linked as to form a single inventive concept under PCT Rule 13.1. In order for all inventions to be searched, the appropriate additional search fees must be paid.

Group I, claim(s) 1-19, drawn to an optical fiber filter.

Group II, claim(s) 20-25, drawn to an optical fiber communication system.

Group III, claim(s) 26-33, drawn to a method of manufacturing a fiber optic filter.

The inventions listed as Groups I, II, and III

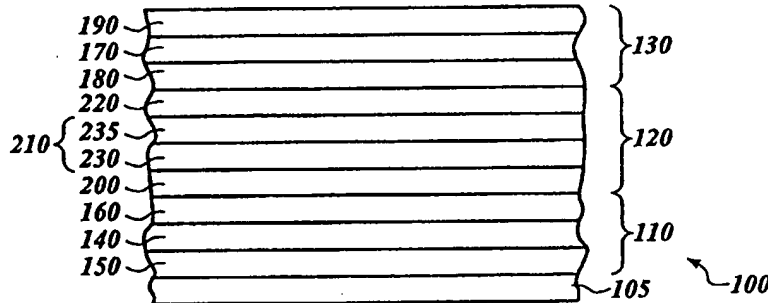
do not relate to a single inventive concept under PCT Rule 13.1 because, under PCT Rule 13.2, they lack the same or corresponding special technical features for the following reasons: Group II requires an optical communication system with a transmitter and a receiver not required by the claims of either Groups I and III. The claims of Group III are directed to a method of making an optical filter, an invention not present in the claims of Groups I and II.



INTERNATIONAL APPLICATION PUBLISHED UNDER THE PATENT COOPERATION TREATY (PCT)

<p>(51) International Patent Classification <sup>7</sup> : H01L 51/20</p>	<p>A1</p>	<p>(11) International Publication Number: <b>WO 00/36665</b> (43) International Publication Date: 22 June 2000 (22.06.00)</p>
<p>(21) International Application Number: PCT/US99/29853 (22) International Filing Date: 15 December 1999 (15.12.99)  (30) Priority Data: 09/212,779 16 December 1998 (16.12.98) US 09/427,138 25 October 1999 (25.10.99) US  (71) Applicant: BATTELLE MEMORIAL INSTITUTE [US/US]; Pacific Northwest Division, Intellectual Property Services, P.O. Box 999, Richland, WA 99352 (US).  (72) Inventors: GRAFF, Gordon, L.; 3750 Westlake Drive, West Richland, WA 99353 (US). GROSS, Mark, E.; 50 Deseret Drive, Pasco, WA 99301 (US). AFFINITO, John, D.; 2718 Kyle Road, Kennewick, WA 99338 (US). SHI, Ming-Kun; 2500 George Washington Way, Richland, WA 99352 (US). HALL, Michael, G.; 4125 Ironton Drive, West Richland, WA 99353 (US). MAST, Eric, S.; 634 Chesnut Avenue, Richland, WA 99352 (US).  (74) Agent: MAY, Stephen, R.; Battelle Memorial Institute, Pacific Northwest Division, Intellectual Property Services, P.O. Box 999, MSIN: K1-53, Richland, WA 99352 (US).</p>		<p>(81) Designated States: JP, KR, European patent (AT, BE, CH, CY, DE, DK, ES, FI, FR, GB, GR, IE, IT, LU, MC, NL, PT, SE).  Published With international search report.</p>

(54) Title: ENVIRONMENTAL BARRIER MATERIAL FOR ORGANIC LIGHT EMITTING DEVICE AND METHOD OF MAKING



(57) Abstract

An encapsulated organic light emitting device. The device includes a first barrier stack (110) comprising at least one first barrier layer (140) and at least one first polymer layer (150, 160). There is an organic light emitting layer stack (120) adjacent to the first barrier stack. A second barrier stack (130) is adjacent to the organic light emitting layer stack. The second barrier stack has at least one second barrier layer (170) and at least one second polymer layer (180, 190). A method of making the encapsulated organic light emitting device is also provided.



*FOR THE PURPOSES OF INFORMATION ONLY*

Codes used to identify States party to the PCT on the front pages of pamphlets publishing international applications under the PCT.

AL	Albania	ES	Spain	LS	Lesotho	SI	Slovenia
AM	Armenia	FI	Finland	LT	Lithuania	SK	Slovakia
AT	Austria	FR	France	LU	Luxembourg	SN	Senegal
AU	Australia	GA	Gabon	LV	Latvia	SZ	Swaziland
AZ	Azerbaijan	GB	United Kingdom	MC	Monaco	TD	Chad
BA	Bosnia and Herzegovina	GE	Georgia	MD	Republic of Moldova	TG	Togo
BB	Barbados	GH	Ghana	MG	Madagascar	TJ	Tajikistan
BE	Belgium	GN	Guinea	MK	The former Yugoslav Republic of Macedonia	TM	Turkmenistan
BF	Burkina Faso	GR	Greece	ML	Mali	TR	Turkey
BG	Bulgaria	HU	Hungary	MN	Mongolia	TT	Trinidad and Tobago
BJ	Benin	IE	Ireland	MR	Mauritania	UA	Ukraine
BR	Brazil	IL	Israel	MW	Malawi	UG	Uganda
BY	Belarus	IS	Iceland	MX	Mexico	US	United States of America
CA	Canada	IT	Italy	NE	Niger	UZ	Uzbekistan
CF	Central African Republic	JP	Japan	NL	Netherlands	VN	Viet Nam
CG	Congo	KE	Kenya	NO	Norway	YU	Yugoslavia
CH	Switzerland	KG	Kyrgyzstan	NZ	New Zealand	ZW	Zimbabwe
CI	Côte d'Ivoire	KP	Democratic People's Republic of Korea	PL	Poland		
CM	Cameroon	KR	Republic of Korea	PT	Portugal		
CN	China	KZ	Kazakstan	RO	Romania		
CU	Cuba	LC	Saint Lucia	RU	Russian Federation		
CZ	Czech Republic	LI	Liechtenstein	SD	Sudan		
DE	Germany	LK	Sri Lanka	SE	Sweden		
DK	Denmark	LR	Liberia	SG	Singapore		
EE	Estonia						

## ENVIRONMENTAL BARRIER MATERIAL FOR ORGANIC LIGHT EMITTING DEVICE AND METHOD OF MAKING

5

### BACKGROUND OF THE INVENTION

The present invention relates to organic light emitting devices (OLEDs), and more particularly to OLEDs encapsulated in barrier stacks.

10 There is a need for versatile visual displays for electronic products of many different types. Light emitting diodes (LEDs) and liquid crystal displays (LCDs) have found many useful applications, but they are not adequate for all situations. OLEDs are a relatively new type of visual display which has shown great promise. An OLED basically includes an organic electroluminescent  
15 substance placed between two electrodes. When an electric potential is applied across the electrodes, the electroluminescent substance emits visible light. Typically, one of the electrodes is transparent, allowing the light to shine through. U.S. Patent Nos. 5,629,389 (Roitman et al.), 5,747,182 (Friend et al.), 5,844,363 (Gu et al.), 5,872,355 (Hueschen), 5,902,688 (Antoniadis et al.), and 5,948,552  
20 (Antoniadis et al.), which are incorporated herein by reference, disclose various OLED structures.

The use of OLEDs in flat panel displays and other information display formats is limited by the poor environmental stability of the devices. G.Gustafson, Y.Cao, G.M.Treacy, F.Klavetter, N.Colaneri, and A.J.Heeger,  
25 Nature, Vol. 35, 11 June 1992, pages 477-479. Humidity and oxygen significantly reduce the useful life of most OLEDs. As a result, these devices are typically fabricated on glass substrates with glass covers laminated on top of the OLED and with the edges sealed to exclude water and oxygen from the active layers. U.S. Patent No. 5,872,355 discloses the use of a polymer such as saran  
30 to seal the device. The water vapor permeation rates (WVTR) required to provide sufficient lifetime for OLEDs is calculated to be approximately  $10^{-6}$  g/m<sup>2</sup>/day. The best polymer films (such as saran) have WVTR values that are 5 orders of magnitude too high to be considered for OLED encapsulation.

Furthermore, saran cannot be deposited using flash evaporation, condensation, and in situ polymerization within a vacuum chamber.

Thus, there is a need for an improved lightweight, barrier construction which can be used to encapsulate the OLED and prevent the deterioration  
5 caused by permeation of oxygen and water vapor and for a method of making such an encapsulated OLED.

#### SUMMARY OF THE INVENTION

10 These needs are met by the present invention, which is an encapsulated organic light emitting device (OLED). The device includes a first barrier stack comprising at least one first barrier layer and at least one first polymer layer. There is an organic light emitting layer stack adjacent to the first barrier stack. A second barrier stack is adjacent to the organic light emitting layer stack. The  
15 second barrier stack has at least one second barrier layer and at least one second polymer layer. The device optionally includes at least one first intermediate barrier stack located between the substrate and the first barrier stack, and/or at least one second intermediate barrier stack located between the organic light emitting layer stack and either the first or second barrier stacks.  
20 The first and second intermediate barrier stacks include at least one polymer layer and at least one barrier layer.

Preferably, either one or both of the first and second barrier layers of the first and second barrier stacks is substantially transparent. At least one of the first and second barrier layers preferably comprises a material selected from  
25 metal oxides, metal nitrides, metal carbides, metal oxynitrides, and combinations thereof. The metal oxides are preferably selected from silica, alumina, titania, indium oxide, tin oxide, indium tin oxide, and combinations thereof, the metal nitrides are preferably selected from aluminum nitride, silicon nitride, and combinations thereof, the metal carbide is preferably silicon carbide, and the  
30 metal oxynitride is preferably silicon oxynitride.

The encapsulated OLED can also include a substrate adjacent to the first barrier stack on a side opposite to the organic light emitting layer stack. The

substrate can be either a flexible substrate or a rigid substrate. It is preferably a flexible substrate material, which can be polymers, metals, paper, fabric, and combinations thereof. The rigid substrate is preferably glass, metal, or silicon. If a rigid substrate is used, it can be removed prior to use if desired.

5           The polymer layers of the first and second barrier stacks and the polymer layers in the first and second intermediate barrier stacks are preferably acrylate-containing polymers (as used herein, the term acrylate-containing polymer includes acrylate-containing polymers, methacrylate-containing polymers, and combinations thereof). The polymer layers in the first and/or the second barrier  
10       stacks can be the same or different.

          The organic light emitting layer stack preferably comprises a first electrode, an electroluminescent layer, and a second electrode. The electroluminescent layer preferably includes a hole transporting layer, and an electron transporting layer, as is known in the art and shown in the patents  
15       whose disclosures have been specifically incorporated herein.

          The invention also involves a method of making the encapsulated organic light emitting device. The method includes forming a first barrier stack comprising at least one first barrier layer and at least one first polymer layer, forming an organic light emitting layer stack, forming a second barrier stack  
20       comprising at least one second barrier layer and at least one second polymer layer, and combining the first barrier stack, the organic light emitting layer stack, and the second barrier stack to form the encapsulated organic light emitting device. Intermediate barrier stacks can optionally be formed. The layers are preferably formed by vacuum deposition.

25           The organic light emitting layer stack can be combined with the first barrier stack and/or the second barrier stack by laminating them together. Alternatively, they can be combined simultaneously with forming by depositing one layer on the other.

          In an alternative embodiment, the invention involves an encapsulated  
30       organic light emitting device having a substrate, an organic light emitting layer stack adjacent to the substrate, and a barrier stack comprising at least one barrier layer and at least one polymer layer, the barrier stack adjacent to the

organic light emitting layer stack. The invention also involves methods of making the encapsulated organic light emitting device. One method includes providing a substrate having an organic light emitting layer stack thereon, and laminating a barrier stack comprising at least one barrier layer and at least one polymer layer over the organic light emitting layer stack to encapsulate the organic light emitting barrier layer stack. The barrier stack is preferably laminated (edge sealed) using an adhesive, but other methods can be used including heat.

Another method involves vacuum depositing the barrier stack on a substrate having an organic light emitting layer stack thereon. Still another method involves providing a substrate with an organic light emitting layer stack thereon, vacuum depositing at least one barrier layer on the organic light emitting layer stack, and depositing at least one first polymer layer on the at least one barrier layer. At least one second polymer layer can be deposited on the organic light emitting layer stack before the barrier layer is deposited.

Accordingly, it is an object of the present invention to provide an encapsulated OLED, and to provide a method of making such a device.

#### BRIEF DESCRIPTION OF THE DRAWINGS

Fig. 1 is a cross-section of one embodiment of the encapsulated OLED of the present invention.

Fig. 2 is a cross-section of an alternate embodiment of the encapsulated OLED of the present invention.

Fig. 3 is a cross-section of an embodiment of an encapsulated OLED of the present invention.

#### DESCRIPTION OF THE INVENTION

One embodiment of the present invention is an encapsulated OLED 100 as shown in Fig. 1. The encapsulated OLED 100 includes substrate 105, a first barrier stack 110, an organic light emitting layer stack 120, and a second barrier stack 130. The first barrier stack 110 has a first barrier layer 140 and two

polymer layers 150, 160. The second encapsulation layer 130 includes a second barrier layer 170 and two polymer layers 180, 190.

Although the Figures show barrier stacks with a single polymer layer on both sides of a single barrier layer, the barrier stacks can have one or more  
5 polymer layers and one or more barrier layers. There could be one polymer layer and one barrier layer, there could be multiple polymer layers on one side of one or more barrier layers, or there could be one or more polymer layers on both sides of one or more barrier layers. The important feature is that the barrier stack have at least one polymer layer and at least one barrier layer.

10 The organic light emitting layer stack 120 includes a first electrode layer 200, an electroluminescent layer 210, and a second electrode 220. The electroluminescent layer 210 can include a hole transport layer 230, and an electron transport layer 235. The exact form and composition of the organic light emitting layer stack is not critical. The organic light emitting layer stack includes  
15 first and second electrode layers on opposite sides of one or more active layers. The electrode layers are connected to a power source. At least one of the electrodes is transparent. The electroluminescent layer may be multiple layers as shown, or a single layer. The electroluminescent layer typically includes a hole injection layer, a hole transport layer, an electron transport layer, and an  
20 emissive layer, and combinations thereof. Additional layers may also be present, including dielectric layers. The organic light emitting layer stack can be made using known techniques, such as those described in U.S. Patent Nos. 5,629,389 (Roitman et al.), 5,844,363 (Gu et al.), 5,872,355 (Hueschen), 5,902,688 (Antoniadis et al.), and 5,948,552 (Antoniadis et al.), which have been  
25 incorporated herein by reference.

The present invention is compatible with organic light emitting layer stacks made with light emitting polymers and small molecules.

In the alternate embodiment shown in Fig. 2, the encapsulated OLED 300 also includes a first intermediate barrier stack 240 and a second intermediate  
30 barrier stack 270. The first intermediate barrier stack is located between the substrate 105 and the first barrier stack 110, and it includes a polymer layer 250 and a barrier layer 260. The second intermediate barrier stack 270 includes a

polymer layer 280 and a barrier layer 290. The second intermediate barrier stack 270 is located between the organic light emitting layer stack 120 and the second barrier stack 130. Alternatively, the second intermediate layer could be located between the first barrier layer and the organic light emitting layer stack.

5 In addition, there could be multiple first intermediate barrier stacks on top of one another to provide enhanced barrier protection. Similarly, there could be multiple second intermediate barrier stacks on top of one another. The order of the barrier and polymer layers in the intermediate barrier stacks is not critical. It depends on where the intermediate barrier stack is located and what layers are

10 next to them.

The encapsulated OLED can be made by forming the first barrier stack 110, the organic light emitting layer stack 120, and the second barrier stack 130. The stacks are combined to form the encapsulated OLED.

Preferably, the stacks are combined by forming them using vacuum

15 deposition. In this method, one layer is vacuum deposited on the previous layer, thereby combining the layers simultaneously with forming them. Alternatively, the organic light emitting layer stack can be combined with the first and second barrier stacks by laminating it between the first and second barrier stacks and sealing it along the edges with adhesive, glue, or the like, or by heating. The first

20 and second barrier stacks include at least one barrier layer and at least one polymer layer. If a polymer/barrier/polymer structure is desired, it can be preferably formed as follows. These barrier stacks can be formed by depositing a layer of polymer, for example an acrylate-containing polymer, onto a substrate or previous layer. Preferably, an acrylate-containing monomer, oligomer or resin

25 (as used herein, the term acrylate-containing monomer, oligomer, or resin includes acrylate-containing monomers, oligomers, and resins, methacrylate-containing monomers, oligomers, and resins, and combinations thereof) is deposited and then polymerized *in situ* to form the polymer layer. The acrylate-containing polymer layer is then coated with a barrier layer. Another polymer

30 layer is deposited onto the barrier layer. U.S. Patent Nos. 5,440,446 and 5,725,909, which are incorporated herein by reference, describe methods of depositing thin film, barrier stacks.

The barrier stacks are preferably vacuum deposited. Vacuum deposition includes flash evaporation of acrylate-containing monomer, oligomer, or resin with *in situ* polymerization under vacuum, plasma deposition and polymerization of acrylate-containing monomers, oligomer, or resin, as well as vacuum  
5 deposition of the barrier layers by sputtering, chemical vapor deposition, plasma enhanced chemical vapor deposition, evaporation, sublimation, electron cyclotron resonance-plasma enhanced vapor deposition (ECR-PECVD), and combinations thereof.

It is critical to protect the integrity of the barrier layer to avoid the formation  
10 of defects and/or microcracks in the deposited layer. The encapsulated OLED is preferably manufactured so that the barrier layers are not directly contacted by any equipment, such as rollers in a web coating system, to avoid defects that may be caused by abrasion over a roll or roller. This can be accomplished by designing the deposition system such that a set of layers of  
15 polymer/barrier/polymer are deposited prior to contacting or touching any handling equipment.

The substrate can be flexible or rigid. The flexible substrate may be any flexible material, including, but not limited to, polymers, for example polyethylene terephthalate (PET), polyethylene naphthalate (PEN), or high temperature  
20 polymers such as polyether sulfone (PES), polyimides, or Transphan™ (a high Tg cyclic olefin polymer available from Lofo High Tech Film, GMBH of Weil am Rhein, Germany), metal, paper, fabric, and combinations thereof. The rigid substrate is preferably glass, metal, or silicon. If a flexible, encapsulated OLED is desired and a rigid substrate was used during manufacture, the rigid substrate  
25 is preferably removed prior to use.

The polymer layers of the first and second barrier stacks and the polymer layers of the first and second intermediate barrier stacks are preferably acrylate-containing monomer, oligomer or resin, and combinations thereof. The polymer layers of the first and second barrier stacks and first and second intermediate  
30 stacks can be the same or they can be different. In addition, the polymer layers within the each barrier stack can be the same or different.



The barrier layers in the barrier stacks and the intermediate barrier stacks may be any barrier material. The barrier materials in the first and second barrier stacks and first and second intermediate barrier stacks can be the same or different. In addition, multiple layers of the same or different barrier layers can  
5 be used in a stack. Preferred transparent barrier materials include, but are not limited to, metal oxides, metal nitrides, metal carbides, metal oxynitrides, and combinations thereof. The metal oxides are preferably selected from silica, alumina, titania, indium oxide, tin oxide, indium tin oxide, and combinations thereof, the metal nitrides are preferably selected from aluminum nitride, silicon  
10 nitride, and combinations thereof, the metal carbide is preferably silicon carbide, and the metal oxynitride is preferably silicon oxynitride.

Since only one side of the device must be transparent, only one of the barrier layers must be transparent. In this situation, the barrier layer on the opposite side could be an opaque barrier material, including, but not limited to,  
15 metal, ceramic or polymer.

An alternate encapsulated OLED is shown in Fig. 3. The encapsulated OLED 400 has a substrate 105 on which is fabricated an organic light emitting layer stack 120. A barrier stack 130 is deposited conformally over the organic light emitting layer stack 120, encapsulating it. The polymer layers in the barrier  
20 stack can be deposited in vacuum or by using atmospheric processes such as spin coating and/or spraying. A preferred method of forming the barrier stack is flash evaporating acrylate-containing monomers, oligomers or resins, condensing on the OLED layer stack, and polymerizing in-situ in a vacuum chamber. The barrier layer is then deposited on the polymer layer using  
25 conventional vacuum processes such as evaporation, sputtering, CVD, PECVD or ECR-PECVD. A second polymer layer is then deposited on the barrier layer using the process described above.

Alternatively, the OLED device could also be encapsulated by laminating a lid structure, containing the barrier stack, to the substrate over the organic light  
30 emitting layer structure. The lamination can be performed using either adhesive, or glue, or the like, or by heating. The encapsulated OLED could also include an

intermediate barrier stack 270 as shown. If the substrate is transparent, then the barrier material could be opaque, or vice versa, as discussed above.

A single pass, roll-to-roll, vacuum deposition of a three layer combination on a PET substrate, i.e., PET substrate/polymer layer/barrier layer/polymer layer, can be more than five orders of magnitude less permeable to oxygen and water vapor than a single oxide layer on PET alone. See J.D.Affinito, M.E.Gross, C.A.Coronado, G.L.Graff, E.N.Greenwell, and P.M.Martin, Polymer-Oxide Transparent Barrier Layers Produced Using PML Process, 39<sup>th</sup> Annual Technical Conference Proceedings of the Society of Vacuum Coaters, Vacuum Web Coating Session, 1996, pages 392-397; J.D.Affinito, S.Eufinger, M.E.Gross, G.L.Graff, and P.M.Martin, PML/Oxide/PML Barrier Layer Performance Differences Arising From Use of UV or Electron Beam Polymerization of the PML Layers, Thin Solid Films, Vol.308, 1997, pages 19-25. This is in spite of the fact that the effect on the permeation rate of the polymer multilayers (PML) layers alone, without the barrier layer (oxide, metal, nitride, oxynitride) layer, is barely measurable. It is believed that the improvement in barrier properties is due to two factors. First, permeation rates in the roll-to-roll coated oxide-only layers were found to be conductance limited by defects in the oxide layer that arose during deposition and when the coated substrate was wound up over system idlers/rollers. Asperities (high points) in the underlying substrate are replicated in the deposited inorganic barrier layer. These features are subject to mechanical damage during web handling/take-up, and can lead to the formation of defects in the deposited film. These defects seriously limit the ultimate barrier performance of the films. In the single pass, polymer/barrier/polymer process, the first acrylic layer planarizes the substrate and provides an ideal surface for subsequent deposition of the inorganic barrier thin film. The second polymer layer provides a robust "protective" film that minimizes damage to the barrier layer and also planarizes the structure for subsequent barrier layer (or organic light emitting layer stack) deposition. The intermediate polymer layers also decouple defects that exist in adjacent inorganic barrier layers, thus creating a tortuous path for gas diffusion. The permeability of the barrier stacks used in the present invention is shown below.

Table 1

Sample	Oxygen Permeation Rate (cc/m <sup>2</sup> /day)		Water vapor Permeation (g/m <sup>2</sup> /day) <sup>†</sup>
	23°C*	38°C*	38°C*
1-barrier stack	<0.005	<0.005	0.46
2- barrier stacks	<0.005	<0.005	<0.005
5-barrier stacks	<0.005	<0.005	<0.005

\* 38°C, 90% RH, 100% O<sub>2</sub>

+ 38°C, 100% RH

NOTE: Permeation rates of <0.005 are below the detection limits of current instrumentation (Mocon OxTran 2/20L).

10 As can be seen from the data in Table 1, the barrier stacks used in the present invention provide exceptional environmental protection, which was previously unavailable with polymers.

We have also compared the performance of OLED devices (fabricated on glass and silicon) before and after encapsulation using the barrier stacks of the present invention. After encapsulation, the current density-versus-voltage and brightness-versus-current density characteristics were identical (within experimental error) to the measured behavior of the pristine (unencapsulated) devices. This shows that the barrier stacks and deposition methods are compatible with OLED device manufacturing.

20 Thus, the present invention provides a barrier stack with the exceptional barrier properties necessary for hermetic sealing of an OLED. It permits the production of an encapsulated OLED.

While certain representative embodiments and details have been shown for purposes of illustrating the invention, it will be apparent to those skilled in the art that various changes in the compositions and methods disclosed herein may be made without departing from the scope of the invention, which is defined in the appended claims.

What is claimed is:

1. An encapsulated organic light emitting device comprising:  
5 a first barrier stack comprising at least one first barrier layer and at least one first polymer layer;  
an organic light emitting layer stack adjacent to the first barrier stack; and  
a second barrier stack comprising at least one second barrier layer and at least one second polymer layer, the second barrier stack adjacent to the organic  
10 light emitting layer stack.
2. The encapsulated organic light emitting device of claim 1 further comprising a substrate adjacent to the first barrier stack on a side opposite to the organic light emitting layer stack.  
15
3. The encapsulated organic light emitting device of claim 2 further comprising at least one first intermediate barrier stack located between the substrate and the first barrier stack, the first intermediate barrier stack comprising at least one third polymer layer and at least one third barrier layer.  
20
4. The encapsulated organic light emitting device of claim 1 further comprising at least one second intermediate barrier stack located between the organic light emitting layer stack and either the first or second barrier stacks, the second intermediate barrier stack comprising at least one fourth polymer layer  
25 and at least one fourth barrier layer.
5. The encapsulated organic light emitting device of claim 1 wherein the at least one first barrier layer is substantially transparent.
- 30 6. The encapsulated organic light emitting device of claim 1 wherein the at least one second barrier layer is substantially transparent.

7. The encapsulated organic light emitting device of claim 1 wherein at least one of the at least one first and second barrier layers comprise a material selected from metal oxides, metal nitrides, metal carbides, metal oxynitrides, and combinations thereof.

5

8. The encapsulated organic light emitting device of claim 7 wherein the metal oxides are selected from silica, alumina, titania, indium oxide, tin oxide, indium tin oxide, and combinations thereof.

10

9. The encapsulated organic light emitting device of claim 7 wherein the metal nitrides are selected from aluminum nitride, silicon nitride, and combinations thereof.

15

10. The encapsulated organic light emitting device of claim 1 wherein the at least one first barrier layer is substantially opaque.

11. The encapsulated organic light emitting device of claim 1 wherein the at least one second barrier layer is substantially opaque.

20

12. The encapsulated organic light emitting device of claim 1 wherein at least one of the at least one first and second barrier layers is selected from opaque metals, opaque polymers, and opaque ceramics.

25

13. The encapsulated organic light emitting device of claim 2 wherein the substrate comprises a flexible substrate material.

30

14. The encapsulated organic light emitting device of claim 13 wherein the flexible substrate material is selected from polymers, metals, paper, fabric, and combinations thereof.

15. The encapsulated organic light emitting device of claim 2 wherein the substrate comprises a rigid substrate material.

16. The encapsulated organic light emitting device of claim 15 wherein the rigid substrate material is selected from glass, metal, and silicon.

17. The encapsulated organic light emitting device of claim 1 wherein at least one of the at least one first polymer layers comprises an acrylate-containing polymer.

18. The encapsulated organic light emitting device of claim 1 wherein at least one of the at least one second polymer layers comprises an acrylate-containing polymer.

19. The encapsulated organic light emitting device of claim 3 wherein at least one of the at least one third polymer layers comprises an acrylate-containing polymer.

20. The encapsulated organic light emitting device of claim 4 wherein at least one of the at least one fourth polymer layers comprises an acrylate-containing polymer.

21. The encapsulated organic light emitting device of claim 1 wherein the organic light emitting layer stack comprises a first electrode, an electroluminescent layer, and a second electrode.

22. The encapsulated organic light emitting device of claim 21 wherein the electroluminescent layer comprises a hole transporting layer, and an electron transporting layer.

23. A method of making an encapsulated organic light emitting device comprising:  
forming a first barrier stack comprising at least one first barrier layer and at least one first polymer layer;  
forming an organic light emitting layer stack;

forming a second barrier stack comprising at least one second barrier layer and at least one second polymer layer; and

combining the first barrier stack, the organic light emitting layer stack adjacent to the first barrier stack, and the second barrier stack adjacent to the organic light emitting layer stack to form the encapsulated organic light emitting device.

24. The method of claim 23 further comprising providing a substrate and forming the first barrier stack on the substrate.

10

25. The method of claim 24 further comprising placing at least one first intermediate barrier stack comprising at least one third polymer layer and at least one third barrier layer between the substrate and the first barrier stack.

15

26. The method of claim 23 further comprising placing at least one second intermediate barrier stack comprising at least one fourth polymer layer and at least one fourth barrier layer between the organic light emitting layer stack and either the first or second barrier stacks.

20

27. The method of claim 23 wherein the organic light emitting layer stack is combined with the first barrier stack by laminating the organic light emitting layer stack to the first barrier stack.

25

28. The method of claim 23 wherein the organic light emitting layer stack is combined with the first barrier stack simultaneously with forming by depositing the organic light emitting layer stack on the first barrier stack.

30

29. The method of claim 23 wherein the second barrier stack is combined with the organic light emitting layer stack by laminating the second barrier stack over the organic light emitting layer stack.

30. The method of claim 23 wherein the second barrier stack is combined with the organic light emitting layer stack simultaneously with forming by depositing the second barrier stack on the organic light emitting layer stack.

5 31. The method of claim 24 wherein the substrate comprises a flexible material.

32. The method of claim 24 wherein the substrate comprises a rigid material.

10 33. The method of claim 24 wherein the substrate is removed from the encapsulated organic light emitting device.

34. The method of claim 23 wherein the first barrier stack is formed by vacuum deposition.

35. The method of claim 23 wherein the organic light emitting layer stack is formed by vacuum deposition.

20 36. The method of claim 23 wherein the second barrier stack is formed by vacuum deposition.

37. The method of claim 23 wherein at least one of the at least one first and second barrier layers is substantially transparent.

25 38. The method of claim 23 wherein at least one of the first and second barrier layers comprises a material selected from metal oxides, metal nitrides, metal carbides, metal oxynitrides, and combinations thereof.

30 39. The method of claim 38 wherein the metal oxides are selected from silica, alumina, titania, indium oxide, tin oxide, indium tin oxide, and combinations thereof.



40. The method of claim 38 wherein the metal nitrides are selected from aluminum nitride, silicon nitride, and combinations thereof.

5 41. The method of claim 23 wherein at least one of the at least one first and second barrier layers is substantially opaque.

42. The method of claim 23 wherein at least one of the at least one first and second barrier layers is selected from opaque metals, opaque polymers, and opaque ceramics.

10

43. The method of claim 31 wherein the flexible substrate material is selected from polymers, metals, paper, fabric, and combinations thereof.

15 44. The method of claim 32 wherein the rigid substrate material is selected from glass, metal, and silicon.

45. The method of claim 23 wherein at least one of the at least one first and second pairs of polymer layers comprises an acrylate-containing polymer.

20 46. The method of claim 25 wherein the third polymer layer comprises an acrylate-containing polymer.

47. The method of claim 26 wherein the fourth polymer layer comprises an acrylate-containing polymer.

25

48. An encapsulated organic light emitting device comprising:  
a first intermediate barrier stack comprising at least one polymer layer and at least one barrier layer ;

30 one first barrier stack comprising at least one first barrier layer and at least one first polymer layer adjacent to the first intermediate barrier stack;

an organic light emitting layer stack adjacent to the first barrier stack;

a second intermediate barrier stack comprising at least one polymer layer and at least one barrier layer, the second intermediate barrier stack adjacent to the organic light emitting layer stack; and

5 a second barrier stack comprising at least one second barrier layer and at least one second polymer layer, the second barrier stack adjacent to the second intermediate barrier stack.

49. The encapsulated organic light emitting device of claim 48 further comprising a substrate adjacent to the first intermediate barrier stack on a side  
10 opposite to the first barrier stack.

50. A method of making an encapsulated organic light emitting device comprising:

forming a first intermediate barrier stack comprising at least one polymer  
15 layer and at least one barrier layer;

forming a first barrier stack comprising at least one first barrier layer and at least one first polymer layer adjacent to the first intermediate barrier stack;

forming an organic light emitting layer stack adjacent to the first barrier  
stack;

20 forming a second intermediate barrier stack comprising at least one polymer layer and at least one barrier layer adjacent to the organic light emitting layer stack; and

forming a second barrier stack comprising at least one second barrier  
layer and at least one second polymer layer adjacent to the second intermediate  
25 barrier stack; and

combining the first intermediate barrier stack, the first barrier stack, the organic light emitting layer stack, the second intermediate barrier stack, and the second barrier stack to form the encapsulated organic light emitting device.

30 51. The method of claim 50 wherein the first intermediate barrier stack is formed by vacuum deposition.

52. The method of claim 50 wherein the first barrier stack is formed by vacuum deposition.

53. The method of claim 50 wherein the organic light emitting layer stack is formed by vacuum deposition.

54. The method of claim 50 wherein the second intermediate barrier stack is formed by vacuum deposition.

55. The method of claim 50 wherein the second barrier stack is formed by vacuum deposition.

56. An encapsulated organic light emitting device comprising:  
a substrate;  
an organic light emitting layer stack adjacent to the substrate;  
a barrier stack comprising at least one barrier layer and at least one polymer layer, the barrier stack adjacent to the organic light emitting layer stack.

57. The encapsulated organic light emitting device of claim 56 further comprising an intermediate barrier stack located between the organic light emitting layer stack and the barrier stack, the intermediate barrier stack comprising at least one polymer layer and at least one barrier layer.

58. The encapsulated organic light emitting device of claim 56 wherein the at least one barrier stack is substantially transparent.

59. The encapsulated organic light emitting device of claim 56 wherein the at least one barrier layer comprises a material selected from metal oxides, metal nitrides, metal carbides, metal oxynitrides, and combinations thereof.

30

60. The encapsulated organic light emitting device of claim 59 wherein the metal oxides are selected from silica, alumina, titania, indium oxide, tin oxide, indium tin oxide, and combinations thereof.

5 61. The encapsulated organic light emitting device of claim 59 wherein the metal nitrides are selected from aluminum nitride, silicon nitride, and combinations thereof.

62. The encapsulated organic light emitting device of claim 56 wherein  
10 the at least one barrier layer is substantially opaque.

63. The encapsulated organic light emitting device of claim 56 wherein the at least one barrier layer is selected from opaque metals, opaque polymers, and opaque ceramics.

15 64. The encapsulated organic light emitting device of claim 56 wherein at least one of the at least one polymer layers comprises an acrylate-containing polymer.

20 65. The encapsulated organic light emitting device of claim 56 wherein the substrate comprises a rigid substrate material.

66. The encapsulated organic light emitting device of claim 56 wherein the rigid substrate material is selected from glass, metal, and silicon.

25 67. The encapsulated organic light emitting device of claim 56 wherein the substrate comprises a flexible substrate material.

30 68. The encapsulated organic light emitting device of claim 67 wherein the flexible substrate material is selected from polymers, metals, paper, fabric, and combinations thereof.

69. A method of making an encapsulated organic light emitting device comprising:

providing a substrate having an organic light emitting layer stack thereon; and

5 vacuum depositing a barrier stack comprising at least one barrier layer and at least one polymer layer over the organic light emitting layer stack to encapsulate the organic light emitting layer stack.

70. The method of claim 69 further comprising depositing an  
10 intermediate barrier layer stack comprising at least one polymer layer and at least one barrier layer on the organic light emitting layer stack prior to vacuum depositing the barrier stack.

71. A method of making an encapsulated organic light emitting device  
15 comprising:

providing a substrate having an organic light emitting layer stack thereon;

vacuum depositing at least one barrier layer over the organic light emitting layer stack;

20 depositing at least one first polymer layer over the at least one barrier layer.

72. The method of claim 71 further comprising depositing at least one  
25 second polymer layer over the organic light emitting layer stack prior to vacuum depositing the at least one barrier layer.

73. The method of claim 71 further comprising depositing an  
intermediate barrier layer stack comprising at least one polymer layer and at  
least one barrier layer on the organic light emitting layer stack prior to depositing  
30 the at least one barrier layer.

74. The method of claim 71 wherein at least one of the at least one first polymer layers is deposited using a process at atmospheric pressure.

5 75. The method of claim 74 wherein the process at atmospheric pressure is selected from spin coating and spraying.

76. The process of 71 wherein at least one of the at least one first polymer layers is deposited using a vacuum process.

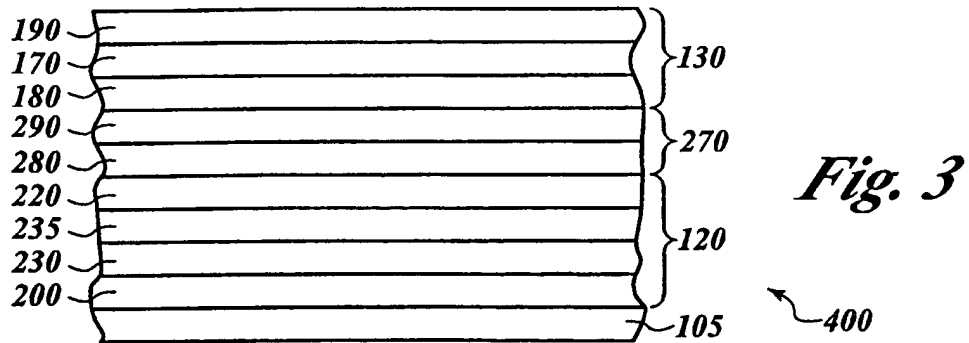
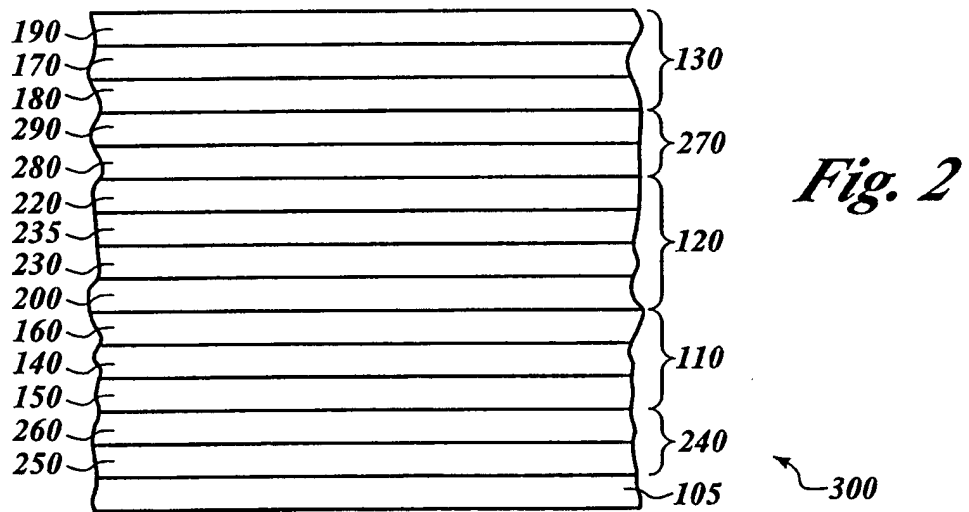
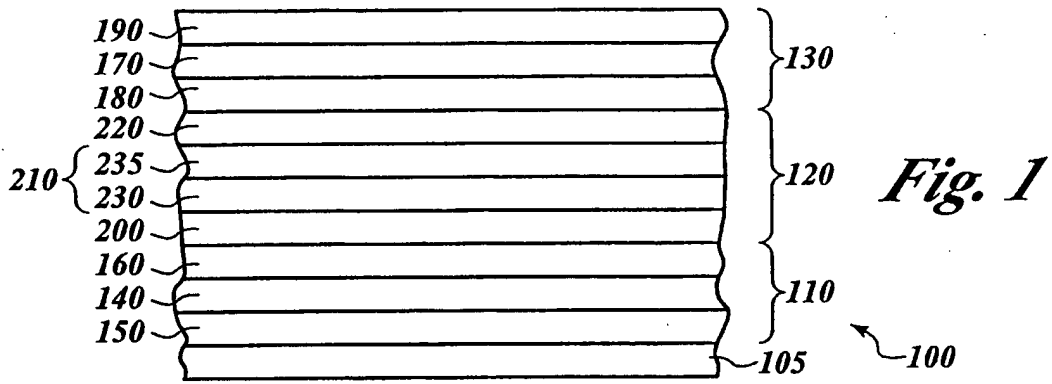
10 77. The method of claim 72 wherein at least one of the at least one second polymer layers is deposited using a process at atmospheric pressure.

78. A method of making an encapsulated organic light emitting device comprising:

15 providing a substrate having an organic light emitting layer stack thereon; and  
laminating a barrier stack comprising at least one barrier layer and at least one polymer layer over the organic light emitting layer stack to encapsulate the organic light emitting layer stack.

20 79. The method of claim 78 wherein the barrier stack is laminated using an adhesive.

25 80. The method of claim 78 wherein the barrier stack is laminated using heat.



# INTERNATIONAL SEARCH REPORT

International Application No  
PCT/US 99/29853

**A. CLASSIFICATION OF SUBJECT MATTER**  
IPC 7 H01L51/20

According to International Patent Classification (IPC) or to both national classification and IPC

**B. FIELDS SEARCHED**

Minimum documentation searched (classification system followed by classification symbols)  
IPC 7 H01L H05B

Documentation searched other than minimum documentation to the extent that such documents are included in the fields searched

Electronic data base consulted during the international search (name of data base and, where practical, search terms used)

**C. DOCUMENTS CONSIDERED TO BE RELEVANT**

Category *	Citation of document, with indication, where appropriate, of the relevant passages	Relevant to claim No.
X	US 5 757 126 A (HARVEY III THOMAS B ET AL) 26 May 1998 (1998-05-26)	1-5, 7-9, 11-14, 21-26, 28, 30, 31, 34, 35, 37-43, 48-53, 56, 57, 62, 63, 67, 68
Y	the whole document	1-9, 11-14, 21-31, 34, 35, 37-43, 48-53, 56-63,
	-/--	

Further documents are listed in the continuation of box C.

Patent family members are listed in annex.

\* Special categories of cited documents :

- "A" document defining the general state of the art which is not considered to be of particular relevance
- "E" earlier document but published on or after the international filing date
- "L" document which may throw doubts on priority claim(s) or which is cited to establish the publication date of another citation or other special reason (as specified)
- "O" document referring to an oral disclosure, use, exhibition or other means
- "P" document published prior to the international filing date but later than the priority date claimed

- "T" later document published after the international filing date or priority date and not in conflict with the application but cited to understand the principle or theory underlying the invention
- "X" document of particular relevance; the claimed invention cannot be considered novel or cannot be considered to involve an inventive step when the document is taken alone
- "Y" document of particular relevance; the claimed invention cannot be considered to involve an inventive step when the document is combined with one or more other such documents, such combination being obvious to a person skilled in the art.
- "&" document member of the same patent family

Date of the actual completion of the international search

22 February 2000

Date of mailing of the international search report

03/03/2000

Name and mailing address of the ISA  
European Patent Office, P.B. 5818 Patentlaan 2  
NL - 2280 HV Rijswijk  
Tel. (+31-70) 340-2040, Tx. 31 651 epo nl,  
Fax: (+31-70) 340-3016

Authorized officer

De Laere, A



INTERNATIONAL SEARCH REPORT

International Application No  
PCT/US 99/29853

C.(Continuation) DOCUMENTS CONSIDERED TO BE RELEVANT		
Category *	Citation of document, with indication, where appropriate, of the relevant passages	Relevant to claim No.
A		67, 68, 78-80 10, 17-20, 36, 45-47, 54, 55, 64, 69-77
X	<p style="text-align: center;">---</p> DE 196 03 746 A (BOSCH GMBH ROBERT) 24 April 1997 (1997-04-24)	56, 58-63, 67, 68, 78-80
Y	the whole document	1-9, 11-14, 21-31, 34, 35, 37-43, 48-53, 56-63, 67, 68, 78-80
A		10, 36, 55, 69, 71, 72, 74-77
A	<p style="text-align: center;">---</p> AFFINITO J D ET AL: "PML/oxide/PML barrier layer performance differences arising from use of UV or electron beam polymerization of the PML layers" THIN SOLID FILMS, CH, ELSEVIER-SEQUOIA S.A. LAUSANNE, vol. 308-309, no. 1-4, 31 October 1997 (1997-10-31), pages 19-25, XP004110238 ISSN: 0040-6090 cited in the application	1, 5, 7, 8, 13, 14, 17, 23, 24, 31, 34, 37-39, 43, 48-50, 52, 56, 58-60, 64, 67-69, 71, 72, 76, 78
	the whole document	
	---	
	-/--	

INTERNATIONAL SEARCH REPORT

International Application No  
PCT/US 99/29853

C.(Continuation) DOCUMENTS CONSIDERED TO BE RELEVANT		
Category*	Citation of document, with indication, where appropriate, of the relevant passages	Relevant to claim No.
A	<p>US 5 547 508 A (AFFINITO JOHN D) 20 August 1996 (1996-08-20)</p> <p>abstract column 3, line 65 -column 4, line 11 ---</p>	<p>1, 5, 7, 8, 10, 12-14, 23, 24, 31, 33, 34, 37-39, 41-43, 48-50, 52, 56, 58-60, 62, 63, 67-69, 71, 72, 76, 78</p>
E	<p>EP 0 977 469 A (HEWLETT PACKARD CO) 2 February 2000 (2000-02-02)</p> <p>the whole document -----</p>	<p>1, 2, 5-9, 13, 14, 17, 18, 21-24, 28, 30, 31, 34-40, 43, 45, 56, 58-61, 64, 67-69, 71, 72, 76</p>

**INTERNATIONAL SEARCH REPORT**

Information on patent family members

International Application No  
PCT/US 99/29853

Patent document cited in search report	Publication date	Patent family member(s)	Publication date
US 5757126 A	26-05-1998	US 5686360 A EP 0777280 A JP 9161967 A	11-11-1997 04-06-1997 20-06-1997
DE 19603746 A	24-04-1997	WO 9716053 A	01-05-1997
US 5547508 A	20-08-1996	US 5395644 A US 5260095 A AT 170779 T CA 2142895 A DE 69320971 D DE 69320971 T EP 0655954 A JP 8503099 T WO 9404285 A	07-03-1995 09-11-1993 15-09-1998 03-03-1994 15-10-1998 27-05-1999 07-06-1995 02-04-1996 03-03-1995
EP 0977469 A	02-02-2000	NONE	

This Page Is Inserted by IFW Operations  
and is not a part of the Official Record

## **BEST AVAILABLE IMAGES**

Defective images within this document are accurate representations of the original documents submitted by the applicant.

Defects in the images may include (but are not limited to):

- BLACK BORDERS
- TEXT CUT OFF AT TOP, BOTTOM OR SIDES
- FADED TEXT
- ILLEGIBLE TEXT
- SKEWED/SLANTED IMAGES
- COLORED PHOTOS
- BLACK OR VERY BLACK AND WHITE DARK PHOTOS
- GRAY SCALE DOCUMENTS

**IMAGES ARE BEST AVAILABLE COPY.**

**As rescanning documents *will not* correct images,  
please do not report the images to the  
Image Problem Mailbox.**

(19) World Intellectual Property Organization  
International Bureau



(43) International Publication Date  
14 February 2002 (14.02.2002)

PCT

(10) International Publication Number  
WO 02/12932 A2

(51) International Patent Classification?: G02B 6/00

(21) International Application Number: PCT/US01/22750

(22) International Filing Date: 18 July 2001 (18.07.2001)

(25) Filing Language: English

(26) Publication Language: English

(30) Priority Data:  
09/633,307 7 August 2000 (07.08.2000) US  
09/903,050 10 July 2001 (10.07.2001) US

(71) Applicant: SYMMORPHIX, INC. [US/US]; 1278  
Reamwood Avenue, Sunnyvale, CA 94089-2233 (US).

(72) Inventors: DEMARAY, Richard, E.; 190 Fawn Lane,  
Portola Valley, CA 94028 (US). WANG, Kai-An; 1082  
West Hill Court, Cupertino, CA 95014 (US). MULLA-  
PUDI, Ravi, B.; 2117 Shiangzone Court, San Jose, CA  
95121 (US). STADTLER, Douglas, P.; 18509 Murphy

Court, Morgan Hill, CA 95037 (US). ZHANG, Hongmei;  
1330 Rodney Drive, San Jose, CA 95118 (US). PETHE,  
Rajiv; 3680 Springbrook Avenue, San Jose, CA 95148  
(US).

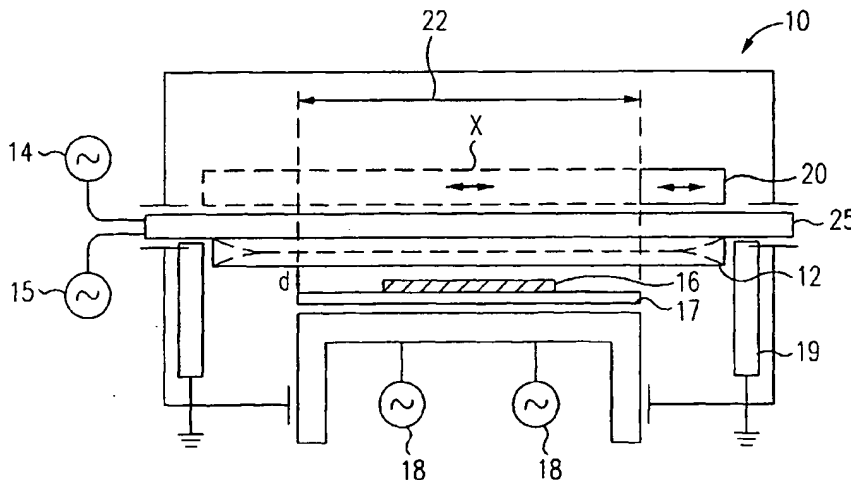
(74) Agents: SAXON, Roberta, P. et al.; Skjerven Morrill  
MacPherson LLP, 25 Metro Drive, Suite 700, San Jose, CA  
95110 (US).

(81) Designated States (national): AE, AG, AL, AM, AT, AU,  
AZ, BA, BB, BG, BR, BY, BZ, CA, CH, CN, CO, CR, CU,  
CZ, DE, DK, DM, DZ, EC, EE, ES, FI, GB, GD, GE, GH,  
GM, HR, HU, ID, IL, IN, IS, JP, KE, KG, KP, KR, KZ, LC,  
LK, LR, LS, LT, LU, LV, MA, MD, MG, MK, MN, MW,  
MX, MZ, NO, NZ, PL, PT, RO, RU, SD, SE, SG, SI, SK,  
SL, TJ, TM, TR, TT, TZ, UA, UG, UZ, VN, YU, ZA, ZW.

(84) Designated States (regional): ARIPO patent (GH, GM,  
KE, LS, MW, MZ, SD, SL, SZ, TZ, UG, ZW), Eurasian  
patent (AM, AZ, BY, KG, KZ, MD, RU, TJ, TM), European  
patent (AT, BE, CH, CY, DE, DK, ES, FI, FR, GB, GR, IE,  
IT, LU, MC, NL, PT, SE, TR), OAPI patent (BF, BJ, CF,  
CG, CI, CM, GA, GN, GW, ML, MR, NE, SN, TD, TG).

[Continued on next page]

(54) Title: PLANAR OPTICAL DEVICES AND METHODS FOR THEIR MANUFACTURE



(57) Abstract: Physical vapor deposition processes provide optical materials with controlled and uniform refractive index that meet the requirements for active and passive planar optical devices. All processes use radio frequency (RF) sputtering with a wide area target, larger in area than the substrate on which material is deposited, and uniform plasma conditions which provide uniform target erosion. In addition, a second RF frequency can be applied to the sputtering target and RF power can be applied to the substrate producing substrate bias. Multiple approaches for controlling refractive index are provided. The present RF sputtering methods for material deposition and refractive index control are combined with processes commonly used in semiconductor fabrication to produce planar optical devices such surface ridge devices, buried ridge devices and buried trench devices. A method for forming composite wide area targets from multiple tiles is also provided.

WO 02/12932 A2



**Published:**

— without international search report and to be republished upon receipt of that report

*For two-letter codes and other abbreviations, refer to the "Guidance Notes on Codes and Abbreviations" appearing at the beginning of each regular issue of the PCT Gazette.*

## PLANAR OPTICAL DEVICES AND METHODS FOR THEIR MANUFACTURE

## 5 RELATED APPLICATIONS

This application claims benefit of Atty. Dkt. No. M-7637-1P US (USSN NOT YET KNOWN), filed 10 July 2001, which is a continuation-in-part of U.S. Serial No.: 09/633,307, filed 7 August 2000, both of which are incorporated herein by reference.

## 10 FIELD OF THE INVENTION

This invention relates generally to planar optical devices and materials and methods used in their manufacture, and, in particular, to optical components such as waveguides and amplifiers, and physical vapor deposition methods for their manufacture.

## 15 BACKGROUND

The increasing prevalence of fiber optic communications systems has created an unprecedented demand for devices for processing optical signals. Planar devices such as optical waveguides, couplers, splitters, and amplifiers, fabricated on planar substrates, like those commonly used for integrated circuits, and configured to receive and process signals from optical fibers are highly desirable. Such devices hold promise for integrated optical and electronic signal processing on a single semiconductor-like substrate.

The basic design of planar optical waveguides and amplifiers is well known, as described, for example in U. S. Patent Nos. 5,119,460 to Bruce et al. 5,613,995 to Bhandarkar et al., (hereafter '995), 5,900,057 to Buchal et al., and 5,107,538 to Benton et al., to cite only a few. The devices consist, very generally, of a core region, typically bar shaped, of a certain refractive index surrounded by a cladding region of a lower refractive index. In the case of an optical amplifier, the core region contains a certain concentration of a dopant, typically a rare earth ion such as an erbium or praseodymium ion which, when pumped by a laser, fluoresces, for example, in the 1550 nm and 1300 nm wavelength range, respectively, used for optical communication, amplifying the optical signal passing through the core.

The performance of these planar optical devices depends sensitively on the value and uniformity of the refractive index of the core region and of the cladding region, and particularly on the difference in refractive index,  $\Delta n$ , between the regions. Particularly for

passive devices such as waveguides, couplers, and splitters,  $\Delta n$  needs to be sensitively controlled at values less than 1 % and the refractive index of both core and cladding need to be highly uniform, for some applications at the fewer than parts per thousand level. In the case of doped materials forming the core region of planar optical amplifiers, it is  
5 important that the dopant be uniformly distributed so as to avoid non-radiative quenching or radiative quenching, for example by upconversion. The refractive index and other desirable properties of the core and cladding regions, such as physical and chemical uniformity, low stress, and high density, depend, of course, on the choice of materials for the devices and on the processes by which they are fabricated.

10 Because of their optical properties, silica and refractory oxides such as  $Al_2O_3$ , are good candidate materials for planar optical devices. Further, these oxides serve as suitable hosts for rare earth dopants used in optical amplifiers. A common material choice is so-called low temperature glasses, doped with alkali metals, boron, or phosphorous have the advantage of requiring lower processing temperatures. In addition, dopants are used to  
15 modify refractive index. Methods such as flame hydrolysis, ion exchange for introducing alkali ions in glasses, sputtering, and various chemical vapor deposition processes (CVD) have been used to form films of doped glasses. However, dopants, such as phosphorous and boron are hygroscopic, and alkalis are undesirable for integration with electronic devices. Control of uniformity of doping in CVD processes can be difficult and CVD  
20 deposited films can have structural defects leading to scattering losses when used to guide light. In addition, doped low temperature glasses may require further processing after deposition. A method for eliminating bubbles in thin films of sodium-boro-silicate glass by high temperature sintering is described, for example, in the '995 patent to Bhandarkar et al.

25 In the case of pure  $SiO_2$ , the most uniform optical material presently known is by atmospheric pressure thermal oxide (APOX). The APOX process can provide a 13  $\mu m$  thick silica film having a precise refractive index of 1.4584, at 1550 nm, with a  $1\sigma$  variance in the refractive index across a 150 mm wafer of  $3 \times 10^{-5}$ . However, the APOX process does not provide a method of making films with different indices of refraction. It  
30 is, therefore, not suitable for forming a waveguide core film with a desired refractive index (n).

Thus, there remains a need for a process to provide optical materials with a specified and uniform index of refraction for planar optical devices. It would be desirable



if the material additionally exhibits high optical transparency, low stress, and high density and is free of structural defects.

#### SUMMARY

5           A physical vapor deposition process provides optical materials with controlled and uniform refractive index that meet the requirements for active and passive planar optical devices. According to a first aspect of the present invention, radio frequency (RF) sputtering of a wide area target in the presence of a sputtering gas under a condition of uniform target erosion is used to deposit physically and chemically uniform material on a  
10 substrate. The substrate is positioned opposite a planar target of the material to be deposited, the area of the target being larger than the area of the substrate. A central area of the target of the same size as the substrate and overlying the substrate is exposed to a uniform plasma condition, which provides a condition of uniform target erosion. A uniform plasma condition can be created without magnetic enhancement, termed diode  
15 sputtering, or by providing a time-averaged uniform magnetic field by scanning a magnet across the target in a plane parallel to the plane of the target.

          According to an aspect of the present invention, a film deposited on the substrate using a wide area target and uniform target erosion is of uniform thickness for targets with an area at least 1.5 times the area of the substrate. In addition, film deposited on a  
20 substrate positioned opposite a central region of the target inside the region providing film thickness uniformity exhibits physical and chemical uniformity useful for fabricating optical devices. The region providing chemical uniformity can be coextensive with the region providing thickness uniformity.

          According to another aspect of the present invention, a dual frequency RF  
25 sputtering process is used in which the high frequency RF power applied to the target is augmented by applying low frequency RF power to the target, resulting in densification of the deposited film and better coverage of features when deposited over underlying layers. Further, the dual frequency RF process can be used to tune the refractive index of the deposited film. Keeping the total RF power the same, the refractive index tends to increase  
30 with the ratio of low frequency to high frequency RF power.

          In yet another method, RF power is applied to the substrate resulting in substrate bias. Substrate bias is used with single frequency or with dual frequency RF sputtering to provide improved density and morphology of deposited films and to complete coverage and filling of features on underlying layers. Furthermore, substrate bias contributes to

uniformity of refractive index. Films deposited by diode sputtering including application of substrate bias demonstrate exceptional refractive index uniformity and low average surface roughness.

According to another aspect of the present invention, the refractive index of the material deposited using an RF sputtering process can be deliberately tuned by modifying other plasma processing conditions. First, raising the deposition temperature increases the refractive index of the resulting material. Second, increasing the RF power applied to the target increases the refractive index of the deposited material. Third, a reactive process gas can be added to the sputtering chamber which effectively modifies the chemical composition of the deposited material with a corresponding change in refractive index. Additionally, the refractive index of deposited material can be modified by using a target material in a specific oxidation state. The RF sputtering method is applicable to depositing pure materials and mixed materials including materials containing rare earth dopants for optical amplifier applications. Thus, wide area RF sputtering can be used together with the present refractive index control methods to provide core and cladding materials with a desired difference in refractive index for planar optical waveguides and optical amplifiers.

The present RF sputtering methods for material deposition and refractive index control are combined with processes commonly used in semiconductor fabrication to produce planar optical devices. A surface ridge optical device is produced by using RF sputtering to deposit a stack comprising an upper cladding layer, a middle core layer, and a lower cladding layer on a substrate. A ridge is etched into the upper cladding layer and partway through the thickness of the core layer to produce the surface ridge device. A buried ridge device is produced by etching a ridge into a layer of core material overlying a cladding layer. A top layer of cladding material is deposited over the core ridge by RF sputtering with substrate bias. Use of substrate bias enables the cladding layer to completely cover the exposed ridge without defects. Further, the deposition methods described here are used to fabricate a buried trench device in which RF sputtering with substrate bias completely fills a trench in a layer of cladding material with core material.

Finally, a method for forming composite wide area targets from multiple tiles is provided. The method includes positioning the tiles on a backing plate in a noncontact array.

## BRIEF DESCRIPTION OF THE DRAWINGS

FIG. 1a is a schematic drawing of a physical vapor deposition apparatus in which wide area target RF sputtering, according to embodiments of the present invention, is performed. FIG. 1b is an expanded view of a portion of the apparatus of FIG. 1a.

5 FIG. 2 is a top down view of the wide area target, scanning magnet, and carrier sheet of the apparatus of FIG. 1.

FIG. 3 is a detail view of a composite target according to an embodiment of the present invention.

10 FIGS. 4a and 4b are cross section views illustrating a process of fabricating a surface ridge planar optical device, in which processes according to embodiments of the present invention, are used.

FIGS. 5a - 5e are cross section views illustrating a process of fabricating a buried ridge planar optical device, in which processes according to embodiments of the present invention, are used.

15 FIGS. 6a - 6f are cross section views illustrating the process of fabricating a buried trench planar optical device, in which processes according to embodiments of the present invention, are used.

20 FIG. 7 is a scanning electron micrograph (SEM) of a layer deposited over a substrate patterned with trenches by a RF sputtering process including substrate bias, according to an embodiment of the present invention.

## DETAILED DESCRIPTION

25 A physical vapor deposition process provides optical materials with controlled and uniform refractive index that meet the requirements for active and passive planar optical devices. The process uses radio frequency (RF) sputtering with a wide area target and a condition of uniform target erosion and includes multiple approaches for controlling refractive index.

30 An apparatus 10 for RF sputtering of controlled refractive index material for planar optical devices is illustrated schematically in FIG. 1a. The apparatus includes a wide area sputter source target 12 which provides material to be deposited on substrate 16. Substrate 16 is positioned parallel to and opposite target 12. Target 12 functions as a cathode when RF power is applied to it and is equivalently termed the cathode. Target 12 is a uniform source of material having a uniform index of refraction. Target 12 is typically composed of pure materials such as quartz, alumina, or sapphire, (the crystalline form of alumina), or mixtures of compounds of optically useful materials. Optically useful materials include

oxides, fluorides, sulfides, nitrides, phosphates, sulfates, and carbonates, as well as other wide band gap semiconductor materials. To achieve uniform deposition, target 12, itself is chemically uniform, flat, and of uniform thickness over an extended area. In practice, target 12 is a composite target fabricated from individual tiles, precisely bonded together  
5 on a backing plate with minimal separation. A method of making chemically uniform tiles of mixed materials and attaching them to a backing plate 25, forming target 12, comprises another aspect of the present invention that is described in detail below. The complete target assembly also includes structures for cooling the target as described in U. S. Patent No. 5,565,071 to Demaray et al, and incorporated herein by reference.

10 For fabricating planar optical devices, substrate 16 is a solid, smooth surface. Typically, substrate 16 is a silicon wafer or a silicon wafer coated with a layer of silicon oxide formed by a chemical vapor deposition process or by a thermal oxidation process. Alternatively, substrate 16 is a glass, such as Corning 1737 (Corning Inc., Elmira, NY), a glass-like material, quartz, a metal a metal oxide, or a plastic material. Substrate 16  
15 typically is supported on a holder or carrier sheet 17 that may be larger than substrate 16.

An essential feature of the present method is that the area of wide area target 12 is greater than the area on the carrier sheet on which physically and chemically uniform deposition is accomplished. Secondly, it is also essential that a central region on target 12, overlying the substrate 16, be provided with a very uniform condition of sputter erosion of  
20 the target material. Uniform target erosion is a consequence of a uniform plasma condition. In the following discussion, all mention of uniform condition of target erosion is taken to be equivalent to uniform plasma condition. Uniform target erosion is evidenced by the persistence of film uniformity throughout an extended target life. A uniform  
25 deposited film is defined as a film having a nonuniformity in thickness, when measured at representative points on the entire surface of a substrate wafer, of less than about 5 %. Thickness nonuniformity is defined, by convention, as the difference between the minimum and maximum thickness divided by twice the average thickness. If films  
deposited from a target from which more than about 20 % of the weight of the target has been removed continue to exhibit thickness uniformity, then the sputtering process is  
30 judged to be in a condition of uniform target erosion for all films deposited during the target life.

Thus, it is essential that a uniform plasma condition be created in the region between the target and the substrate overlying the substrate. The region of uniform plasma condition is indicated in the exploded view of FIG. 1b. A plasma is created in the region

denoted 51, which extends under the entire target 12. The central region of the target 52, experiences the condition of uniform sputter erosion. As discussed further below, a layer deposited on a substrate placed anywhere below central region 52 will have uniform film thickness.

5           In addition, the region in which deposition provides uniform film thickness is larger than the area in which deposition provides a film with uniform physical or optical properties such as chemical composition or index of refraction. In the present invention it is essential that the target be planar or approximately planar for the formation of a film on a planar substrate which is to be coated with the material of the target. In practice,  
10 planarity of the target means that all portions of the target surface in region 52 are within a few millimeters of a planar surface, typically within 0.5 mm.

Multiple approaches to providing a uniform condition of sputter erosion of the target material can be used. A first approach is to sputter without magnetic enhancement. Such operation is referred to as diode sputtering. Using a large area target with a diode  
15 sputtering process, a dielectric material can be deposited so as to provide suitably uniform film thickness over a central portion of an adjacent substrate area. Within that area, an area of highly uniform film may be formed with suitable optical uniformity. The rate of formation of films of many microns of thickness by diode sputtering can be slow for small targets. However, in the present method, using large targets, a disadvantage in speed of  
20 diode sputtering can be compensated by batch processing in which multiple substrates are processed at once.

Other approaches to providing a uniform condition of sputter erosion rely on creating a large uniform magnetic field or a scanning magnetic field that produces a time-averaged, uniform magnetic field. For example, rotating magnets or electromagnets can be  
25 utilized to provide wide areas of substantially uniform target erosion. For magnetically enhanced sputter deposition, a scanning magnet magnetron source is used to provide a uniform, wide area condition of target erosion. Diode sputtering is known to provide uniform films; the magnetron sputtering process described here provides diode-sputtering-like uniformity in a magnetically enhanced sputtering process.

30           As illustrated in FIG. 1a, apparatus 10 also includes a scanning magnet magnetron source 20 positioned above target 12. A scanning magnetron source used for dc sputtering of metallic films is described in U. S. Patent No. 5,855,744 to Halsey, et. al., (hereafter '744), which is incorporated herein by reference, and in references therein. The '744 patent demonstrates the improvement in thickness uniformity that is achieved by reducing

local target erosion due to magnetic effects in the sputtering of a wide area rectangular target. By reducing the magnetic field intensity at these positions, the local target erosion was decreased and the resulting film thickness nonuniformity was improved from 8%, to 4%, over a rectangular substrate of 400 x 500 mm.

5           A top down view of magnet 20 and wide area target 12 is shown in FIG. 2. A film deposited on a substrate positioned on carrier sheet 17 directly opposed to the region of the target indicated by reference numeral 22 has good thickness uniformity. Area 22 is the same size as region 52 of the target, FIG. 1b, that is exposed to a uniform plasma condition. In some implementations, carrier 17 is coextensive with region 22. Reference  
10   24 indicates the area below which both physically and chemically uniform deposition is achieved, where physical and chemical uniformity provide refractive index uniformity. FIG. 2 indicates that the region 22 of the target providing thickness uniformity is, in general, larger than the region 24 of the target providing thickness and chemical  
15   uniformity. In optimized processes, however, regions 22 and 24 may be coextensive.

15           Magnet 20 extends beyond area 22 in one direction, the Y direction in FIG. 2, so that scanning is necessary in only one direction, the X direction, to provide a time averaged uniform magnetic field. As shown in FIGS. 1a and 1b, magnet 20 is scanned over the entire extent of target 12 which is larger than the region 52 of uniform sputter erosion. Magnet 20 is moved in a plane parallel to the plane of the target.

20           Using a wide area target and a scanning magnet to RF sputter a planar silica target 12 of dimension 550 x 650 mm, a film with thickness nonuniformity of  $\pm 5\%$  has been obtained on a substrate placed opposite a region of the target of dimension 300 x 400 mm. The thickness nonuniformity of a 300 mm diameter circular substrate at the center of this  
25   region can be less than  $\pm 3\%$ . Refractive index nonuniformity at the 150 mm center of the region of less than one part in a thousand has been obtained. The results reported here have been obtained, however, without extensive optimization. Those skilled in the art will recognize that by changing details of the scanning of the magnet, such as the tilt and dwell of the magnet, as described, for example, in '744, further optimization can be achieved. A useful general criterion for the present method of RF sputter deposition, therefore, is that  
30   the wide area target be at least 1.5 times the area of the region on the carrier sheet on which physically uniform deposition is obtained. Since the carrier sheet can accommodate a single large substrate or multiple smaller substrates, the criterion can be expressed as the requirement that the area of the target be at least 1.5 times the area of the substrate.

Alternative sputter source designs might be expected to provide a film on a 150 mm wafer with a thickness nonuniformity less than 5%. The results reported for sample C in Example 1 below, demonstrate 4.4% thickness nonuniformity, which corresponds to slightly more than 1.5 % 1 sigma variance. As sample C shows, the nonuniformity of the index of refraction is .067%, or less than 1 part in a thousand. What is not obvious is that a film with more than 1.5 % 1 sigma thickness variance should have a uniformity of index of refraction more than an order of magnitude better. According to one aspect of the present invention, the uniform index of refraction is due to the attributes of the wide area, uniform region of target erosion.

The present method using a wide area target with uniform sputter erosion offers significant advantages over previous deposition approaches. It is possible to form a film with uniform thickness using a target that is smaller in plane area than the substrate. One way to do so is to move the substrate with respect to the source or cathode in such a fashion that the film formed is uniform in thickness. However, such a film will not have been formed under uniform process conditions, such as plasma density, the rate and angle of arrival of the vapor at the substrate, etc. Thus such films will not be uniform in physical properties such as density, refractive index, or resistivity, resulting in nonuniform optical and electrical performance.

It is also well known that it is possible to form a film of uniform thickness from a nonuniform sputter source, say a sputter target with a stationary sputter groove having substantial and increasingly nonuniform erosion through the useful portion of the target life. Such an approach is described, for example, in U.S. Patent No. 5,252,194 to Demaray et al. Similarly, such a nonuniform source of material will not form a film having uniform electrical or optical properties. The example of the ring or cone shaped sputter source illustrates one effect. The anisotropy of the angle of arrival alone can have a substantial effect on the density of the film that is formed. Since the transmission of optical dielectric

uniform film thickness. In addition, the region of uniform film thickness is greater than or equal to the region of the film which is to have highly uniform optical properties such as index of refraction, density, transmission or absorptivity.

Returning to FIG. 1a, apparatus 10 includes RF generator 14 for applying RF  
5 power to target 12 to generate a plasma in a background gas. RF generator 14 is a high frequency source, conventionally operated at 13.56 MHz. Typical process conditions for RF sputter deposition include applying high frequency RF power in the range of about 500 to 5000 watts. An inert gas, typically, argon, is used as the background sputtering gas. The deposition chamber is operated at low pressure, between about .5 millitorr and 8-10  
10 millitorr. Typical process pressure is below about 2 millitorr where there are very few collisions in the gas phase, resulting in a condition of uniform "free molecular" flow. This ensures that the gas phase concentration of a gaseous component is uniform throughout the process chamber.

For example, in the apparatus used in the Examples below, background gas flow  
15 rates in the range of about 30 to about 100 sccm, used with a pump operated at a fixed pumping speed of about 50 liters/second, result in free molecular flow conditions. The distance  $d$ , in FIG. 1a, between the target and the substrate is varied between about 4 cm and 9 cm. A typical source to substrate distance  $d$  is 6 cm. The source to substrate distance is chosen to optimize the thickness uniformity of the film. At large source to substrate  
20 distances the film thickness distribution is dome shaped with the thickest region of the film at the center of the substrate. At close source to substrate distance the film thickness is dish shaped with the thickest film formed at the edge of the substrate. The substrate temperature is held constant in the range of about  $-40^{\circ}\text{C}$  to about  $550^{\circ}\text{C}$  and can be maintained at a chosen temperature to within about  $10^{\circ}\text{C}$  by means of preheating the substrate and the  
25 substrate holder prior to deposition. During the course of deposition, the heat energy impressed upon the substrate by the process must be conducted away from the substrate by cooling the table on which the substrate is positioned during the process, as known to those skilled in the art. The process is performed under conditions of uniform gas introduction, uniform pumping speed, and uniform application of RF power to the periphery of the  
30 target as known to skilled practitioners.

The speed at which a scanning magnet 20 is swept over the entire target is determined such that a layer thickness less than about 5 to 10 Å, corresponding roughly to two to four monolayers of material, is deposited on each scan. The rate at which material is deposited depends on the applied RF power and on the distance  $d$ , in FIG. 1a, between



the target 12 and the substrate 16. With the silica target described above, scanning speeds between about 2 sec/one-way scan across the target to 20-30 sec/scan provide a beneficial layer thickness. Limiting the amount of material deposited in each pass promotes chemical and physical uniformity. With the typical process conditions, the rate of deposition of pure silica is approximately 0.8 Å/kW-sec. At an applied RF power of 1 kW, the rate of deposition is 0.8 Å/sec. At a magnet scan speed that provides a scan of 2 seconds, a film of 1.8 Å nominal thickness is deposited.

A thickness of 2.4 Å can be associated with one monolayer of amorphous silica film. The impingement rate of process gas equivalent to a monolayer per second occurs at approximately  $1 \times 10^{-6}$  torr. The process gas may contain oxygen atoms ejected from the silica during sputtering in addition to the background inert gas. For typical process conditions near 1 millitorr,  $4 \times 10^3$  monolayers of process gas impinge on the film during the 4 second period of deposition. These conditions provide adequate means for the equilibration of the adsorbed sputtered material with the process gas, if the sputtered material has a uniform composition. Uniform, wide area target erosion is required so as to ensure that the adsorbed sputtered material has a uniform composition.

According to another aspect of the present invention, a dual frequency RF sputtering process, in which low frequency RF power is also applied to the target, is used. Returning to FIG. 1a, apparatus 10 includes RF generator 15, in addition to RF generator 14 described previously. RF generator 14 is a high frequency source, typically 13.56 MHz, while RF generator 15 provides power at a much lower frequency, typically from about 100 to 400 kHz. Typical process conditions for dual frequency RF deposition include high frequency RF power in the range of about 500 to 5000 watts and low frequency RF power in the range of about 500 to 2500 watts where, for any given deposition, the low frequency power is from about a tenth to about three quarters of the high frequency power. The high frequency RF power is chiefly responsible for sputtering the material of target 12. The high frequency accelerates electrons in the plasma but is not as efficient at accelerating the much slower heavy ions in the plasma. Adding the low frequency RF power causes ions in the plasma to bombard the film being deposited on the substrate, resulting in sputtering and densification of the film.

In addition, the dual frequency RF deposition process generally results in films with a reduced surface roughness as compared with single frequency deposition. For silica, films with average surface roughness in the range of between about 1.5 and 2.6 nm have been obtained with the dual frequency RF process. Experimental results for single and

dual frequency deposition are further described in Example 4 below. As discussed in the co-filed, commonly assigned U.S. application Attorney Docket No. M-11522 US, (the '522 application) which is incorporated herein by reference, reducing surface roughness of core and cladding materials is key to reducing scattering loss in planar optical devices.

5 Further, the dual frequency RF process can be used to tune the refractive index of the deposited film. Keeping the total RF power the same, the refractive index of the deposited film tends to increase with the ratio of low frequency to high frequency RF power. For example, a core layer of a planar waveguide can be deposited by a dual frequency RF process, and the same target 12, can be used to deposit a cladding layer  
10 using a single frequency RF process. Introducing low frequency RF power in the core layer deposition process can therefore be used to provide the difference in refractive index between core and cladding layer materials.

It is particularly beneficial to further augment the single frequency or dual frequency RF sputtering process by additionally applying RF power to the substrate 16,  
15 using, for example, substrate RF generator 18. Applying power to the substrate, resulting in substrate bias, also contributes to densification of the film. The RF power applied to the substrate can be either at the 13.56 MHz high frequency or at a frequency in the range of the low frequency RF. Substrate bias power similar to the high frequency RF power can be used.

20 Substrate bias has been used previously to planarize sputter deposited quartz films. A theoretical model of the mechanism by which substrate bias operates, has been put forward by Ting et al. (J. Vac. Sci. Technol. 15, 1105 (1978)). When power is applied to the substrate, a so-called plasma sheath is formed about the substrate and ions are coupled from the plasma. The sheath serves to accelerate ions from the plasma so that they  
25 bombard the film as it is deposited, sputtering the film, and forward scattering surface atoms, densifying the film and eliminating columnar structure. The effects of adding substrate bias are akin to, but more dramatic than, the effects of adding the low frequency RF component to the sputter source.

Using the bias sputtering process, the film is simultaneously deposited and etched.  
30 The net accumulation of film at any point on a surface depends on the relative rates of deposition and etching, which depend respectively, on the power applied to the target and to the substrate, and to the angle that the surface makes with the horizontal. The rate of etching is greatest for intermediate angles, on the order of 45 degrees, that is between about 30 and 60 degrees.

The target and substrate powers can be adjusted such that the rates of deposition and etching are approximately the same for a range of intermediate angles. In this case, films deposited with bias sputtering have the following characteristics. At a step where a horizontal surface meets a vertical surface, the deposited film makes an intermediate angle with the horizontal. On a surface at an intermediate angle, there will be no net deposition since the deposition rate and etch rate are approximately equal. There is net deposition on a vertical surface.

A bias sputtering process without magnetic enhancement has been observed to provide deposited films with exceptionally low surface roughness and exceptional refractive index uniformity. As described in Example 5 below, using substrate bias in a diode sputtering process, a silica film with an average surface roughness of 0.14 nm and a refractive index uniformity of less than  $4 \times 10^{-5}$  % has been obtained. Further, as demonstrated in FIG. 7, diode bias sputtering produces structures with the characteristic intermediate angle of the external surface of the film portion covering a raised ridge. Diode bias sputtering therefore, offers particular advantages for forming the core layer of certain waveguide structures, as further discussed in the '522 application.

Dual frequency RF sputter deposition processes or single or dual frequency RF sputtering including substrate bias provide dense films with excellent physical structure for use in planar optical devices. The present processes overcome problems that have been observed in the past in some conventionally deposited, particularly CVD deposited films, which can display so-called "columnar", through thickness structure. In cross section, under magnification, the structure appears like a close packed group of columns or grains. Between the columns, there is often a diffusion path, referred to as "leader" defects. The columnar morphology contributes to the roughness of the surfaces and sidewalls of conventional films after etching during fabrication into devices. The through thickness defects as well as the surface roughness scatters guided light, resulting in insertion and transmission losses. Thus the transparency of materials produced by dual frequency and substrate bias deposition is advantageous for building low loss optical devices.

The use of substrate bias can also influence the refractive index of the deposited film. In the case of an argon gas process, it can be expected that substrate bias will result in densification and etching of the film. An argon bias process can be expected to rise the index of a film deposited from a pure  $\text{SiO}_2$  target. However, the rate of etching is proportional to the local plasma density and that density is proportional to the local plasma density at the target cathode. Here again, the uniformity of the target plasma, as

demonstrated by the uniformity of the nearby target erosion is very important for the uniformity of the effect of the substrate bias. Thus, use of substrate bias reinforces the benefits of the wide area target used under condition of uniform target erosion, of the present invention, to provide films with highly uniform optical properties.

5           According to another aspect of the present invention, the refractive index of the material deposited using an RF sputtering process can be deliberately tuned by modifying other plasma processing conditions, provided that such process conditions influence a substantially uniform region of a wide area cathode in a uniform way. First, it has been determined that raising the deposition temperature increases the refractive index of the  
10           resulting material. Second, increasing the RF power applied to the target increases the refractive index of the deposited material. Third, a reactive process gas can be added to the sputtering chamber which effectively modifies the chemical composition of the deposited material with a corresponding change in refractive index. In general, adding a reducing gas, such as hydrogen, increases the refractive index and adding an oxidizer, such  
15           as oxygen, decreases the refractive index. Nitrogen is also a useful process gas. The direction of the effect on refractive index of replacing some of the argon with nitrogen depends on the chemical composition of the target.

          For example, as reported in detail in Example 1, for a pure silica, that is  $\text{SiO}_2$ , target, increasing the process temperature from 40 °C to 400 °C results in an over 0.7 %  
20           increase in refractive index, from 1.438 to 1.449. The process temperature is the temperature at which the substrate carrier 17 is uniformly maintained. All refractive indices reported here are measured at 1550 nm. Increasing the process power from 800 W to 1200 W increases the refractive index of the deposited material by about 0.5 %. Larger changes can be effected by using higher process power or by using reactive process gases  
25           in the sputtering chamber. Replacing a third of the argon with nitrogen at 150 °C provides an increase in refractive index of about 7 %. Replacing argon as the sputtering gas with a mixture of 2%  $\text{H}_2$  in Ar results in an increase in refractive index of over 2% at 150 °C.

          Another approach to providing material with a tailored refractive index is to employ a target material in a specific oxidation state. In the silicon/oxygen system, for  
30           example, the refractive index of a bulk  $\text{SiO}_2$  target is typically around 1.44. Using the present refractive index control methods with an  $\text{SiO}_2$  target, materials with refractive indices between 1.44 and 1.58 have been obtained. Alternatively, as demonstrated in Example 3, target 12 can be composed of silicon monoxide,  $\text{SiO}$ , which in the bulk state has a refractive index on the order of 1.8. RF sputtered  $\text{SiO}$  using argon as the sputtering

gas has a refractive index slightly above 2, while SiO that was sputtered using a mixture of argon and nitrogen can have a refractive index lowered by over 15% to below 1.75, depending on the process conditions.

While not bound by any theory, the inventors explain the observed process gas effects on refractive index in the silicon/oxygen system in terms of free electron density on the silicon atoms in the material. Metallic silicon with a high electron density has a high refractive index, about 3.4. Combining silicon atoms with oxygen, which is highly electronegative, that is electron withdrawing, reduces the electron density on silicon, reducing the refractive index to 1.8, for SiO, and to 1.44 for SiO<sub>2</sub>. During sputtering of SiO, some of the oxygen is removed by collision with argon ions in the plasma, resulting in sputtered material with a higher refractive index than the SiO target. Nitrogen atoms are electronegative, but not as strongly electronegative as oxygen. When nitrogen is used as a process gas in sputtering of SiO, some nitrogen is added to SiO to form SiON, in which the N adds to withdrawing electrons from Si, lowering the refractive index. However, when nitrogen is used in sputtering of SiO<sub>2</sub>, some nitrogen replaces oxygen to form some SiON. In this case, the nitrogen is less electronegative than the oxygen and the refractive index goes up. With this understanding, the practitioner can use reactive process gases to tune refractive index at will.

For passive optical devices, differences in refractive index between the core and the cladding of between about 0.25% and 1.5% are typically required. Thus, wide area RF sputtering can be used together with choice of target oxidation state and refractive index control by varying temperature, power and/or reactive gas to produce both core and cladding materials with a desired  $\Delta n$ . The ability to reproducibly and uniformly provide materials with a range of refractive index enables designers to optimize optical components for geometric or other considerations and specify the desired refractive index of the materials rather than being limited to the values that result from conventional CVD deposition processes.

The specific examples discussed to this point have focused on deposition from targets composed of oxides of silicon. The wide area target RF sputtering process is likewise advantageous for deposition of rare earth doped materials used for the core region of planar optical amplifiers. To deposit rare earth doped materials, a target that is a mixture or compound of the rare earth, typically an oxide, fluoride, sulfide, or nitride, and a suitable oxide host is used. For example, to deposit Er doped SiO, powdered SiO and Er<sub>2</sub>O<sub>3</sub> is thoroughly mixed, and formed into tiles by low temperature isostatic pressure.

The present method can be applied to provide rare earth compounds doped in any of the combinations of oxides, including silica and alumina, or silica and alumina augmented by such other host material as yttria, zirconia, titania, or other materials that have been proposed for optical amplifier applications. A mixture of rare earth dopants can be  
5 provided, as desired.

Doping oxides of silicon with erbium raises the refractive index of the doped material with respect to the refractive index of the host material. For example, as reported here in sample C of Example 2, a film with an Er concentration of approximately  $2 \times 10^{20}$  atoms/cm<sup>3</sup> in SiO<sub>2</sub>, deposited by RF sputtering, has a refractive index that is 2.3% above  
10 that of RF sputtered SiO<sub>2</sub>. The difference in refractive index between the doped core region and the cladding region has an important effect on the performance of planar optical amplifiers. For amplifiers,  $\Delta n$  values between about 0.25% and 15% are typically required. The index control methods described here are beneficially used to provide cladding region materials with a suitable  $\Delta n$  with respect to the doped core region. In the  
15 past, additional, so-called tertiary, species such as alkali, phosphorous, boron, and ceria have been introduced into optical layers for refractive index control, raising the index of the core or bringing the refractive index of the cladding up to a desired  $\Delta n$  from the refractive index of the doped core. Such tertiary species can diffuse into the core region and detrimentally interfere with rare earth ion luminescence. Moreover, such tertiary  
20 species can raise the coefficient of thermal expansion of the material causing stress and birefringence problems. The present method of wide area target RF sputtering with index control avoids the disadvantages of index modification by tertiary additives.

The chief requirement for applying the present method to deposit doped mixed oxide materials for use in optical amplifiers is that the wide area alloy target be completely  
25 uniform in chemical composition, at least to the level of the powder metallurgy utilized to form the powder mixture. Typical powder sizes are between tens and hundreds of microns. In the case of refractory oxide additions, it may be useful to pre-alloy these with the rare earth additions. Plasma spray, transient melting or induction melting may be utilized to form a powder which is a solution or alloy of such materials. In the case of  
30 mixed materials containing alumina, for example, the low sputter yield of pure alumina can lead to segregation of the target material during sputtering. This causes the film to be low in aluminum with respect to the alloy target composition. It also can lead to particle production from the cathode. The high solubility of the rare earth material in alumina and the high sputter efficiency of the rare earth doped alumina suggest that practical formation

of a sputter target material proceed through a first step of alloying the rare earth dopant and one or more of the host oxide additions to form a first powder material. The remainder of the host materials can be added prior to consolidation of the alloy target material. With this understanding the practitioner can fabricate alloy tiles of uniform composition.

5           According to yet another aspect of the present invention, a method of forming targets 12 composed of individual tiles is provided. In order to form a wide area target of an alloy target material, the consolidated material must first be uniform to the grain size of the powder from which it is formed. It also must be formed into a structural material capable of forming and finishing to a tile shape having a surface roughness on the order of  
10 the powder size from which it is consolidated. As an example, the manufacture of indium tin oxide targets for wide area deposition has shown that it is impractical to attempt to form a single piece, wide area target of fragile or brittle oxide material. The wide area sputter cathode is therefore formed from a close packed array of smaller tiles. A target of a size used in the Examples herein may have from 2 to 20 individual tiles. The tiles are finished  
15 to a size so as to provide a margin of non-contact, tile to tile, 29 in FIG. 3, less than .0010" to 0.020" or less than half a millimeter so as to eliminate plasma process between the tiles. The distance of the target tile assembly comprising target 12 to the dark space anode or ground shield 19, in Figs. 1a and 1b can be somewhat larger so as to provide non contact assembly or provide for thermal expansion tolerance during process chamber conditioning  
20 or operation.

          The low thermal expansion and fragile condition of ideal optical dielectric tile material can be a cause of great difficulty in bonding and processing a wide area array of such tiles. The bonding process according to the present invention that overcomes these difficulties is illustrated in FIG. 3. Sputter coating a side of such a tile in region 26 prior to  
25 bonding with backing plate 25 can be accomplished with a layer of a material such as chrome or nickel as a diffusion layer. Such a metallurgical layer acts as a wetting layer to be tinned with a suitable solder material such as indium or an indium alloy. The backing plate 25 should be made of titanium or molybdenum or other low expansion metal so as to provide a good match with the thermal expansion of the tile material. A very important  
30 aspect of the formation of a tiled target is the finishing and coating of the backing plate prior to the solder bonding of the array of tiles. The portion 27 of the backing plate to be exposed to vacuum, either between the tiles or about the periphery or dark space region of the tile assembly should be bead blasted and plasma spray coated with a material such as alumina or silica to prevent contamination of the process by the target backing plate

material. The portion 26 of the backing plate beneath the tile should be sputter coated with a material such as nickel or chrome to enable solder bonding. Pure indium solder, although it has a higher melting point than alloys such as indium-tin, is much more ductile. This allows the solder to yield during cooling of the solder bonded assembly relieving stress on the bonded tiles.

It is useful to provide an outer frame fixture which is located precisely for the location of the outer tiles. It is also useful to provide shim location, tile to tile, while the assembly is at temperature. The actual solder application and lay up procedure can be devised by those versed in solder assembly. It is essential for reasons of heat transfer that the solder forms a full fill of the volume between the tile and the backing plate. It is also essential that the solder not be exposed to the plasma. There should not be any visible solder in the region between the tiles or on the backing plate. To enable this condition it is useful to sputter coat the wetting layer area with an offset 28 of several millimeters on both the tile and the backing plate. It is also useful to pre-solder or tin both the tiles and the backing plate prior to final assembly. The solder material will not wet region 28 upon assembly. A mask for the sputter deposition of the diffusion barrier/wetting layer film is useful. Finally, cleaning of the bonded target tile assembly should utilize anhydrous cleaning rather than aqueous based cleaning methods.

The RF sputtering methods for material deposition, described here, are combined with processes commonly used in semiconductor fabrication, such as photo-lithographic patterning and etching, to produce planar optical devices. A process to produce a surface ridge device is illustrated schematically in the device cross sections of Figs. 4a and 4b. RF sputtering is used to deposit a layer of cladding material 34 on a substrate 32. A layer of core material 36, having a higher index of refraction than the cladding layer is then deposited by RF sputtering on the cladding layer 34, followed by another layer 34 of the cladding material, as shown in FIG. 4a. A ridge structure 31 is then formed in the upper cladding layer and a portion of the core material, as required by the design of the waveguide, by means of lithography and etching, FIG. 4b. The ridge 31, serves to guide the light in the core material. In the case that the core material is doped with a photoluminescent active material and the conditions for amplification are met, such a structure may be used as a planar waveguide amplifier device.

Figs. 5a-5e illustrate the steps of forming a buried ridge planar wave-guide. FIG. 5a shows the same sequence of films as FIG. 4a without the upper cladding layer. FIG. 5b shows a ridge 37 that has been formed by lithography and etching from the core layer 36.



The ridge is shown as unity aspect ratio but might have another aspect in cross section. Fig 5c illustrates the conformity or ridge coverage shape 38 of an overlayer of the cladding material formed by means of standard RF sputtering. The line of sight arrival of the sputtered cladding material results in poor step coverage of those portions of the ridge  
5 having low solid angle exposure to the sputter cathode source. The film grows in a lateral direction from the upper corners of the ridge resulting in a 'bread loaf' shape. The overhang of the lateral growth causes the rate of deposition to decrease at the lower corner of the ridge. A 'bird's beak' shaped defect in the coverage is formed in the covering film. In micro-electronic applications, such a 'bird's beak', or leader, defect is the cause of  
10 electrical breakdown of an insulating dielectric layer. In the present optical application, a buried ridge wave-guide having an upper cladding as shown in FIG. 5c would demonstrate poor single mode confinement and substantial polarization dependence for the guided light due to the 'bird's beak' defect. Substantial insertion loss would result from the roughness introduced by the defect in the longitudinal direction of the wave-guide.

15 FIG. 5d illustrates the effect of dual frequency RF deposition on the formation of the coverage of the ridge. Using dual RF frequencies, a small amount of ion bombardment of the cladding layer 39 can be achieved during deposition, providing a small etch rate to reduce the lateral growth of the deposition on the top corners of the ridge. The small etch rate during deposition reduces the shadowing at the lower corner of the ridge and increases  
20 the step coverage. The low amount of ion bombardment also acts to densify the film by forward scattering of the adsorbed, sputtered material and provides for increased mobility of the sputtered material on the surface of the film. Both effects act to reduce the leader defect shown in FIG. 5c. FIG. 5d shows the improved step coverage 39 that can result from the application of dual frequency power for the sputter deposition of the upper  
25 cladding. Due to the fact that the lower frequency, of the dual frequency process, is applied to the cathode, the deposition rate will increase with the addition of the second frequency power. Thus, the positive effect of the second frequency can not be isolated from the deposition rate. However, the structure, shown in FIG. 5d, is not an ideal structure for the formation of a light wave guiding device because the step coverage defect has not been  
30 eliminated.

FIG. 5e shows the effect of the addition of substrate bias during the sputter deposition of the upper cladding layer. The substrate bias power is independent of the source power. The addition of further bias power to the substrate will increase the etch rate. In practice it may be equal to the source power. The rate of deposition of the film

will be significantly greater on the horizontal features of the substrate than the rate of etching. However, due to the efficiency of ion etching of a feature of the film inclined near 45 degrees from the horizontal surface, the net accumulation at that angle may be very low. By adjusting the ratio of the bias to the sputter power, an angle of constant repose can be  
5 impressed upon the accumulation shape of the deposited cladding layer.

FIG. 5e shows schematically the step coverage that can be obtained in the cladding layer 40 by bias sputtering. FIG. 7 demonstrates that the smooth, straight sidewalls and characteristic 45 degree angles depicted schematically in FIG. 5e are achieved in practice. In particular, the leader defect and the shadowing effect of unbiased deposition can be  
10 completely eliminated. The step coverage can be increased by increasing the thickness of layer 40. While the discussion above has emphasized the beneficial geometrical effects of bias sputtering deposition of cladding layer 40, it is also useful to use bias sputtering to deposit all the layers of planar optical devices because of the increased transparency of bias sputtered materials. Also, since bias sputtering affects refractive index, it is desirable  
15 to use bias sputtering for both lower and upper cladding layers in order for the cladding layers to have the same refractive index.

A wave guide device 30, as shown in FIG. 5e, with very low polarization dependence and high quality mode containment can be obtained in a material such as pure silica. If such a device is realized in pure silica without the use of dopants, substantial  
20 improvement in thermal stability over present devices can be achieved. Device 30 may be used as a wave-guide or splitter. When the core is rare earth doped, it may be utilized to form an active device such as an optical amplifier. When formed by thin film methods, arrays of such devices may be created. Exemplary dimensions of the cross section of ridge 31 or 37 or core 46, discussed below, are from about  $2 \times 2 \mu\text{m}$  to about  $9 \times 9 \mu\text{m}$ .  
25 Exemplary dimensions for cladding layer 34 is between about 10 and 25  $\mu\text{m}$  thick.

The process of forming a trench device 50 is shown schematically in Figs. 6a – 6f. First, a thick layer 41 of cladding material is deposited by RF sputtering on substrate 32, FIG. 6a. Next a trench 42 is formed by photo-lithographic patterning and etching in cladding layer 41, FIG. 6b. Core material 43 may be RF sputtered into the trench, FIG. 6c.  
30 As in the case of covering a ridge, the lateral growth of the surface film shadows the line of sight coverage of the trench. The maximum thickness of the bottom fill of an aspect one trench with a film of unity thickness may be less than 10 to 20 %. In practice, the core layer can close off, leaving a void in the trench. The best prior art, teaches that the film 43 should be etched back. An etch back process removes the surface layer, opens the void if

one has formed and leaves the partial fill in the trench, (see H. Ohkubo, et. al. "Polarization-Insensitive Arrayed-Waveguide Grating Using Pure SiO<sub>2</sub> Cladding, Proc. OECC 2000, Technical Digest, July 2000, Makuhari Messe, Japan.). A second deposition can fill the partially filled trench. In contrast, FIG. 6d shows the cladding layer applied by means of a dual frequency process. Using dual frequency, layer 44 remains open due to the etching influence of the second lower frequency. The bottom fill can increase to as much as 60 to 80 %. While dual RF deposition is more successful at filling the trench than single frequency deposition, the process is not ideal for fabrication of buried trench waveguides.

10 According to the present invention, a trench can be filled in a single process step using bias sputtering. FIG. 6e schematically shows core material deposited by means of RF bias sputtering of layer 45. FIG. 7 demonstrates complete trench fill has been achieved in practice with bias sputtering. The structure of FIG. 6e can be etched back by means of a bias process with the net rate of bias etching greater than the rate of deposition on the horizontal surface. It can also be mechanically polished or etched back. Deposition of a cladding layer by means of RF sputtering results in device 50 shown in FIG. 6f. Device 50 can be used as a polarization independent wave guide. In the prior art, Ohkubo, et. al., the core material was doped with germania to raise the index of refraction. In the present invention, the control of the index of deposited pure silica can be used to provide the higher index material of the core as a uniform layer. The wide area magnetron RF source will also provide a uniform plasma condition for the application of the uniform bias sputtering.

In the case of wave length division, Ohkubo, et. al. utilize a three step process of deposition, etch back and deposition to fill a trench between two ridge waveguide structures. In the design of planar waveguide structures there are many instances in which two core waveguide structures, formed either by etching a ridge or filling a trench, are brought together either to merge, thus forming a so called '3 dB' junction, or into close proximity so as to form a coupler. In these cases, narrow, deep structures are formed. In all these cases it is necessary to fill these structures of adjacency between nearby waveguides. According to the present invention, the trench fill, the ridge coverage and the adjacent structure fill can be accomplished uniformly in the subject wide area RF bias sputtering process. In all cases, it is also necessary to adjust the index of refraction difference to a precise value. Such a value of  $\Delta n$  may be chosen from 0.1 to 0.8 percent for the purpose of weak mode confinement at a wavelength or for control of the numerical

aperture of a waveguide device. The index difference may need to be uniform to  $\pm 5\%$  of the difference for each film. The overall nonuniformity of each film, 1 percent of 5 percent is  $5 \times 10^{-4}$ . Evaluated at a nominal index of 1.50, such a nonuniformity corresponds to a variance of 0.00075 for each film. The nonuniformity of index reported here and achieved  
5 by means of wide area RF sputtering is, on first result, very close to the estimated value required for each film.

The features and benefits of the present methods of wide area target RF sputtering to provide materials for planar optical devices are further illustrated in the following examples which are offered by way of illustration, but not of limitation.

10

#### EXAMPLE 1: DEPOSITION OF $\text{SiO}_2$

An AKT 1600 series PVD production reactor (Applied Komatsu Technology, Santa Clara, CA) modified for RF application with custom ceramic tile targets was used for RF sputter deposition of  $\text{SiO}_2$ . A wide area target of dimension 550 x 650 mm was fabricated  
15 from four quartz tiles, each 4 mm thick, Corning code 9780 glass (Corning Inc. Elmira, NY). The tiles were finished to a smooth surface, chemically cleaned, rinsed with hot deionized water, dried, and sputter coated with several microns of chrome. The chrome coated sides were bonded to a thin plate of titanium as described above. The titanium  
20 backing plate was prepared for bonding by bead blasting, chemical cleaning, and plasma coating with silicon. The tiles and the backing plate were heated to approximately 180 °C and regions were coated with a layer of liquid indium. The tiles were precisely placed on the backing plate such that they were separated by no more than 0.02 inches from each  
other and from the edges of the region exposed to the plasma.

A 150 mm p-type silicon wafer substrate was placed in the center of a 400 x 500  
25 mm glass carrier sheet. 800 watts of power was applied to the target at 13.56 MHz. A race-track shaped magnet of approximate dimension 150 mm x 600 mm was swept over the face of the target at a rate of 4 seconds per one-way scan (8 seconds per complete cycle.) Substrate temperature was uniformly held at 40 °C and the sputter gas was 99.99999% pure argon at a flow rate of 60 sccm. The target to substrate distance was 6.5  
30 cm. Deposition efficiency was approximately 0.8 Å/kW-sec. Film thickness and index of refraction were measured at five equally spaced points over the full face of the wafer using a FilmTek 4000 interferometer. Refractive index at 1550 nm was  $1.437998 \pm 0.001297$  (0.09%); film thickness was 9227.66 nm with a nonuniformity of 6.8 %. Results are included as Sample A in Table 1 below.

EXAMPLE 2: DEPOSITION OF SiO<sub>2</sub> WITH INDEX MODIFICATION

SiO<sub>2</sub> films were deposited by processes analogous to that described in Example 1, varying deposition temperature, applied power, and process gas. Results are tabulated in Table 1 below.

5 Table 1: SiO<sub>2</sub> Thickness and Refractive Index as Function of Deposition

Conditions

	Power (watts)	Temperature (°C)	Sputtering gas/ Flow rate (sccm)	Refractive index* at 1550 nm	Thickness (nm) <sup>#</sup>
A	800	40	Ar/60	1.437998 (0.001297)	9227.66 (6.8%)
B	800	150	Ar/60	1.440923 (0.001979)	3133.25
C	800	400	Ar/60	1.450126 (0.000726)	9295.86 (4.8%)
D	1200	150	Ar/60	1.448610 (0.000976)	9.2 x 10 <sup>3</sup>
E	800	150	2%H <sub>2</sub> in Ar/60	1.462198 (0.001809)	1287.15
F	800	150	N <sub>2</sub> /20, Ar/40	1.580249 (0.008346)	608.87
G	1400	150	N <sub>2</sub> /20, Ar/40	1.548439 (0.006499)	2354.80
H	800	400	Ar/60	1.450036 (0.000702)	9295.84 (4.8%)

\* Standard deviation (1σ) in parentheses

<sup>#</sup> Thickness nonuniformity

## 10 EXAMPLE 3: DEPOSITION OF SiO AND ERBIUM DOPED SiO

Target tiles of SiO were prepared from a powder of SiO by low temperature isostatic pressure. The tiles were cut and bonded to a backing plate as described above. Mixed oxide tiles used to deposit erbium doped SiO were prepared by mixing powdered Er<sub>2</sub>O<sub>3</sub> and SiO in a ratio of 2 molar cation percent erbia. SiO and Er doped SiO films were deposited as in Examples 1 and 2 above. Refractive index and thickness are tabulated for SiO in Table 2 and for Er doped SiO (SiO:Er) with an Er concentration of approximately 2 x 10<sup>20</sup> Er atoms/ cm<sup>3</sup>, in Table 3.

15

Table 2: SiO Thickness and Refractive Index as Function of Deposition Conditions

	Power (watts)	Temperature (°C)	Sputtering gas/ Flow rate (sccm)	Refractive index* at 1550 nm	Thickness (nm)
J	1000	150	Ar/60	2.084500	691.78
K	1000	150	N <sub>2</sub> /10, Ar/50	1.736693 (0.010250)	1000.96
L	1000	150	N <sub>2</sub> /25, Ar/50	1.740680	770.08

\* Standard deviation ( $1\sigma$ ) in parentheses

Table 3: SiO:Er Thickness and Refractive Index as Function of Deposition Conditions

	Power (watts)	Temperature (°C)	Sputtering gas/ Flow rate (sccm)	Refractive index* at 1550 nm	Thickness (nm)
M	1000	150	Ar/60	2.132870	791.35
N	1000	150	N <sub>2</sub> /10, Ar/50	1.740480 (0.017838)	1501.04
O	1000	150	N <sub>2</sub> /25, Ar/50	1.750910	1400.11
P	1000	150	N <sub>2</sub> /50, Ar/25	1.792790	786.78
Q	800	400	O <sub>2</sub> /3, Ar/57	1.454825 (0.005425)	1159.50

\* Standard deviation ( $1\sigma$ ) in parentheses

#### 5 EXAMPLE 4: SINGLE AND DUAL FREQUENCY RF SPUTTER DEPOSITION OF SILICA

An AKT 1600 series PVD production reactor and wide area target as described in Example 1 was used. High frequency (13.56 MHz) and low frequency (about 350 kHz) process powers are listed along with surface roughness and refractive index (RI) of the deposited films in Table 4 below. Depositions were all conducted at Ar flow rates of 40 standard cubic centimeters per minute (sccm) and at or near room temperature, except as noted below. Refractive index at 1.5  $\mu$ m was measured using a Film Tek 4000 normal incidence interferometer (SCI, Encinitas, CA). Average surface roughness,  $R_a$ , was determined from Atomic Force Microscopy (AFM) measurements using a NanoScope III 15 5000 instrument (Digital Instruments, Veeco Metrology Group, Santa Barbara, CA)

Table 4. Average Surface Roughness and Refractive Index of RF Sputtered Silica

EXAMPLE	HF Power (kW)	LF Power (kW)	R <sub>a</sub> (nm)	RI	Total Power	LF/HF Power Ratio
A	2.3	--	2.988	1.4492	2.300	0
B	2.3	--	2.804	1.4494	2.300	0
C	2.3	--	3.412	1.4473	2.300	0
D	2.0	0.350	1.818	1.4538	2.350	0.175
E	2.0	0.350	1.939	1.4533	2.350	0.175
F	2.0	0.350	2.007	1.4547	2.350	0.175
G	2.0	0.350	2.571	1.4520	2.350	0.175
H	1.7	0.600	1.729	1.4560	2.300	0.353
I	1.7	1.000	1.445	1.4617	2.700	0.588
J	3.0	0.525	2.359	1.4542	3.525	0.175
K*	2.0	0.350	3.419	1.4523	2.350	0.175
L <sup>#</sup>	3.0	0.525	4.489	1.4449	3.525	0.175

\* Deposition temperature 225 °C

# Ar flow rate 120 sccm

Films deposited with a single frequency RF process (Examples A-C) had average surface roughness values in the range of 2.8 to 3.4 nm while the dual frequency process produced films with systematically lower average surface roughness of between 1.4 and 2.6 nm. Keeping other process conditions the same, increasing the ratio of low frequency to high frequency power is seen to result in decreasing surface roughness. Refractive index is observed to have the opposite proportional dependence on power ratio; increasing the low frequency power contribution results in films with higher refractive index. Beneficially, the higher refractive index material has the lower average surface roughness. Thus, in similar processes, core layer material can be obtained by using dual frequency deposition without use of dopants to modify the index of either layer, while using only the high frequency component produces a material of lower refractive index suitable for the cladding layer.

## EXAMPLE 5: RF SPUTTER DEPOSITION OF SILICA WITH SUBSTRATE BIAS

An AKT 4300 series PVD production reactor (Applied Komatsu Technology, Santa Clara, CA) modified to accept custom ceramic tile targets and modified to induce a voltage on the substrate was used to deposit silica on planar and patterned 100 mm silicon wafers.

5 A wide area target of dimension 750 x 870 mm was fabricated as described in Example 1. The wafers were placed in the center of a Corning code 1739 glass carrier sheet opposite the target. The reactor was operated in the diode sputtering mode, without magnetic enhancement, at a high frequency RF power of 2500 W and an induced voltage of -400V. A bias voltage of -125 V at 2 MHz and 250 W was induced on the substrate. An argon gas  
10 flow rate of 160 sccm was used.

Average surface roughness of a 0.75  $\mu\text{m}$  thick film deposited on a planar wafer, determined as in Example 4, was 0.14 nm. The refractive index determined as the average of measurements at 12 points on the surface was 1.4622 with a uniformity, defined as the difference of the minimum and maximum values divided by twice the average, of  $3.4 \times 10^{-5}$  percent. To the best knowledge of the inventors, the exceptional uniformity reported here  
15 exceeds that of any vacuum deposited film reported previously.

FIG. 7 shows an SEM image of a silica film deposited over a patterned substrate. The trenches in the patterned substrate are seen to be completely and uniformly filled and the ridges are uniformly covered. The top surface of the layer overlying the ridges is flat  
20 and the sloping sides of the layer overlying the ridges are nominally at 45 degree angles. All of the foregoing geometric features are characteristic of bias sputtering deposition. As reported above, for trench features with unit aspect ratio, the maximum thickness at the bottom of the trench of films deposited by conventional RF sputtering is less than about 10-20%.

25 Although the present invention has been described in terms of specific materials and conditions, the description is only an example of the invention's application. Various adaptations and modifications of the processes disclosed are contemplated within the scope of the invention as defined by the following claims.



## CLAIMS

We claim:

1. A method of making a material layer used in forming planar optical devices, the method comprising:
  - 5 positioning a substrate opposite a planar target, the target having an area larger than the area of the substrate; and
  - applying radiofrequency power at a first frequency to the target in the presence of a gas, under a condition wherein a central portion of the target overlying the substrate is exposed to a uniform plasma condition, whereby a
  - 10 material layer is formed on the substrate.
2. The method of Claim 1 wherein the uniform plasma condition is created by applying a time-averaged uniform magnetic field.
- 15 3. The method of Claim 2 wherein the uniform magnetic field is applied by moving a magnet positioned proximate to the target across the target in a plane parallel to the plane of the target.
4. The method of Claim 3 wherein moving a magnet across the target is
- 20 moving a magnet in a first direction, the magnet extending beyond the target, in a second direction perpendicular to the first direction.
5. The method of Claim 1 wherein the area of the planar target is at least 1.5 times greater than the area of the substrate.
- 25 6. The method of Claim 5 wherein the material layer deposited on the substrate has a thickness nonuniformity of less than 5 percent.
7. The method of Claim 6 wherein the material layer deposited on the
- 30 substrate has a nonuniformity in an optical property that is smaller than a nonuniformity in thickness.

8. The method of Claim 1 further comprising applying radiofrequency power at a second frequency to the target wherein the second frequency is lower than the first frequency.

5 9. The method of Claim 1 further comprising applying radiofrequency power to the substrate.

10. The method of Claim 8 further comprising applying radiofrequency power to the substrate.

10

11. The method of Claim 1 wherein the uniform plasma condition is created without use of a magnet and further comprising applying radiofrequency power to the substrate.

15

12. The method of Claim 1 wherein the target comprises refractory oxides.

13. The method of Claim 12 wherein the target comprises oxides of silicon.

14. The method of Claim 13 wherein the target comprises silicon monoxide.

20

15. The method of Claim 12 wherein the target further comprises compounds of rare earths.

16. The method of Claim 8 wherein the refractive index of a first material layer deposited with the radiofrequency power at the second frequency at a first power level is higher than the refractive index of a second material layer deposited with the radiofrequency power at the second frequency at a second power level, wherein the first power level is higher than the second power level and wherein the sum of the power levels of the first frequency and the second frequency are the same during deposition of the first material layer and the second material layer.

30

17. The method of Claim 1 wherein the refractive index of a first material layer deposited with the substrate held at a first temperature is higher than the refractive index of

a second material layer deposited with the substrate held at a second temperature wherein the first temperature is higher than the second temperature.

18. The method of Claim 1 wherein the refractive index of a first material layer  
5 deposited at a first radiofrequency power is higher than the refractive index of a second  
material layer deposited at a second radiofrequency power wherein the first power is  
higher than the second power.
19. The method of Claim 1 wherein the gas comprises an inert gas.  
10
20. The method of Claim 1 wherein the gas further comprises a reactive gas  
whereby the refractive index of the material layer is modified compared with the refractive  
index of a material layer formed in the absence of the reactive gas.
21. The method of Claim 20 wherein the reactive gas is a reducing gas and  
15 wherein the refractive index of the material layer is greater than the refractive index of a  
material layer formed in the absence of the reducing gas.
22. The method of Claim 20 wherein the reactive gas is an oxidizing gas and  
20 wherein the refractive index of the material layer is smaller than the refractive index of a  
material layer formed in the absence of the oxidizing gas.
23. The method of Claim 1 wherein the target comprises a plurality of tiles.
24. The method of Claim 23 wherein the tiles comprise an alloy material.  
25
25. A method of making a planar optical device, the method comprising:  
depositing a first layer of cladding material having a first refractive index  
on a substrate by physical vapor deposition to form a first structure, wherein  
30 radiofrequency power is applied to a planar source of cladding material positioned  
opposite the substrate, the source having an area greater than the area of the  
substrate, the power applied in the presence of a gas and under a condition wherein  
a central portion of the source overlying the substrate is exposed to a uniform  
plasma condition; and

depositing a layer of core material on the cladding material to form a second structure, the core material having a second refractive index greater than the first refractive index, the core material deposited by physical vapor deposition, wherein radiofrequency power is applied to a planar source of core material positioned  
5 opposite the first structure, the source of core material having an area greater than the area of the first structure, the power applied in the presence of a gas and under a condition wherein a central portion of the source of core material overlying the first structure is exposed to a uniform plasma condition;

10 26. The method of Claim 25 further comprising:

depositing a second layer of cladding material on the layer of core material by physical vapor deposition wherein radiofrequency power is applied to the planar source of cladding material positioned opposite the second structure under a condition wherein a central portion of the source overlying the second structure is  
15 exposed to a uniform plasma condition; and

etching regions of the second layer of the cladding material and a portion of the thickness of the layer of core material to produce a ridge structure in the second layer of cladding material and in a portion of the layer of core material.

20 27. The method of Claim 25 further comprising;

etching regions of the layer of core material to produce a ridge structure in the layer of core material, forming a third structure; and

depositing a second layer of cladding material over the ridge structure by physical vapor deposition wherein

25 radiofrequency power is applied to the planar source of cladding material positioned opposite the third structure, under a condition wherein the central portion of the source of cladding material overlying the third structure is exposed to a uniform plasma condition, and

radiofrequency power is applied to the third structure.

30

28. The method of Claim 27 wherein depositing the first layer of cladding material further comprises applying radiofrequency power to the substrate.

29. The method of Claim 28 wherein depositing the layer of core material further comprises applying radiofrequency power to the second structure.

30. A method of making a planar optical device, the method comprising:  
5 depositing a first layer of cladding material having a first refractive index on a substrate by physical vapor deposition, wherein radiofrequency power is applied to a planar source of cladding material positioned opposite the substrate, the source having an area greater than the area of the substrate, the power applied in the presence of a gas and under a condition wherein a central portion of the  
10 source overlying the substrate is exposed to a uniform plasma condition;  
forming a trench in the first layer of cladding material to form a first structure;  
depositing a layer of core material on the cladding material completely filling the trench, the core material having a second refractive index greater than  
15 the first refractive index, the core material deposited by physical vapor deposition, wherein radiofrequency power is applied to the first structure and radiofrequency power is applied to a planar source of core material positioned opposite the first structure, the source of core material having an area greater than the area of the substrate, the power applied in the presence of a gas and under a condition wherein  
20 a central portion of the source of core material overlying the first structure is exposed to a uniform plasma condition;  
removing core material overlying the first layer of cladding material exposing the cladding material except in the area of the trench to provide a cladding layer with filled trench; and  
25 depositing a layer of cladding material on the cladding layer with filled trench by physical vapor deposition wherein radiofrequency power is applied to the planar source of cladding material positioned opposite the cladding material with filled trench.

30 31. The method of Claim 30 wherein depositing a first layer of cladding material further comprises applying radiofrequency power to the substrate, and wherein depositing a layer of cladding material on the cladding layer with filled trench further comprises applying radiofrequency power to the cladding layer with filled trench.

32. A method of making a composite sputtering target comprising a plurality of tiles, the target used for physical vapor deposition of material, the method comprising:
- sputter coating a side of each of the plurality of tiles with a wetting layer material to within an offset of the edge of each tile;
  - 5 providing a backing plate composed of a metal with thermal expansion coefficient similar to the thermal expansion coefficient of the plurality of tiles;
  - plasma spray coating the backing plate with a ceramic material so as to cover the regions of the backing plate exposed during physical vapor deposition;
  - sputter coating regions of the backing plate corresponding in placement to  
10 the wetted regions of the tiles with a wetting layer;
  - wetting the sputtered regions of the plurality of tiles and of the backing plate with solder material; and
  - assembling the plurality of tiles on the backing plate so as to form a solder bonded non contacting array of uniformly spaced tiles.
- 15
33. The method of Claim 32 wherein the plurality of tiles comprise an alloy material.
34. The method of Claim 32 wherein the wetting layer material comprises  
20 chrome or nickel or mixtures thereof.
35. The method of Claim 32 wherein the ceramic material comprises alumina or silica.
- 25 36. The method of Claim 32 wherein the solder material is indium.

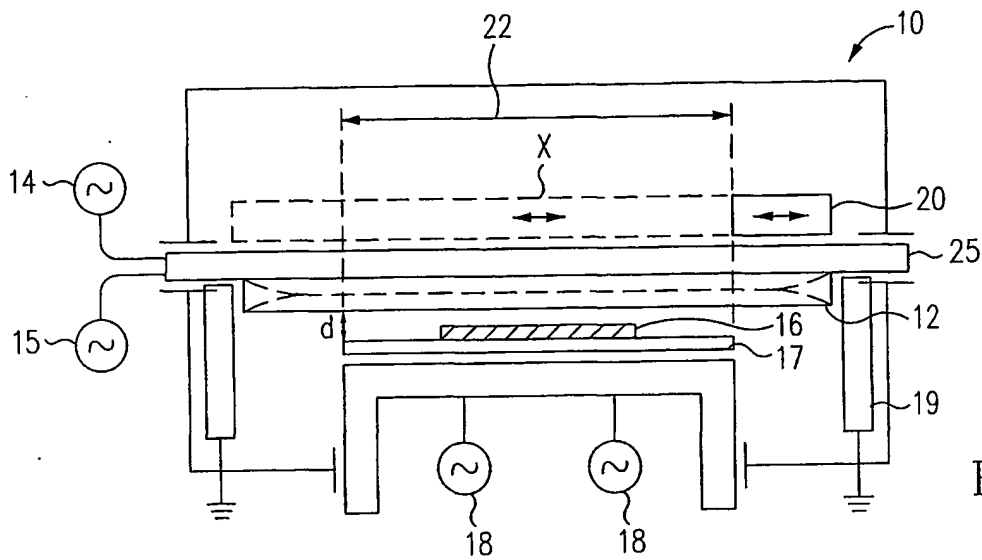


FIG. 1a

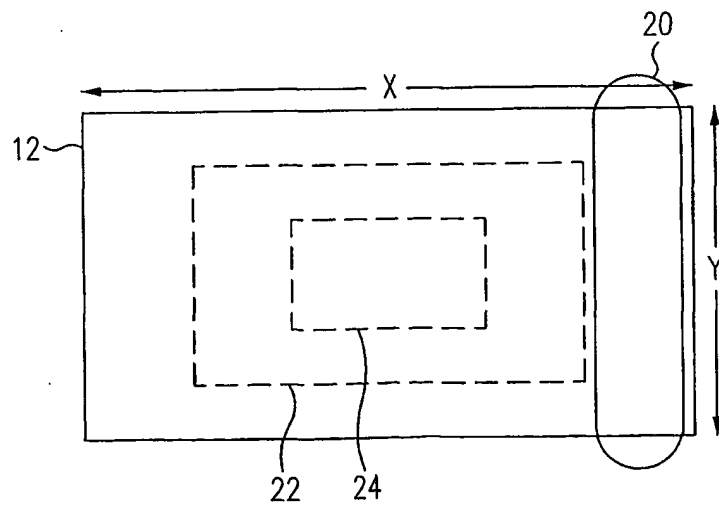


FIG. 2

2/5

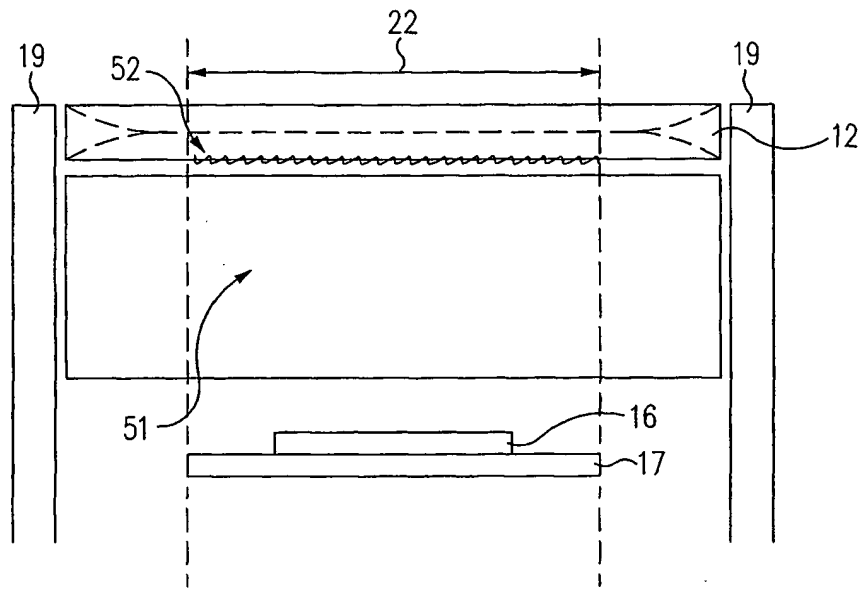


FIG. 1b

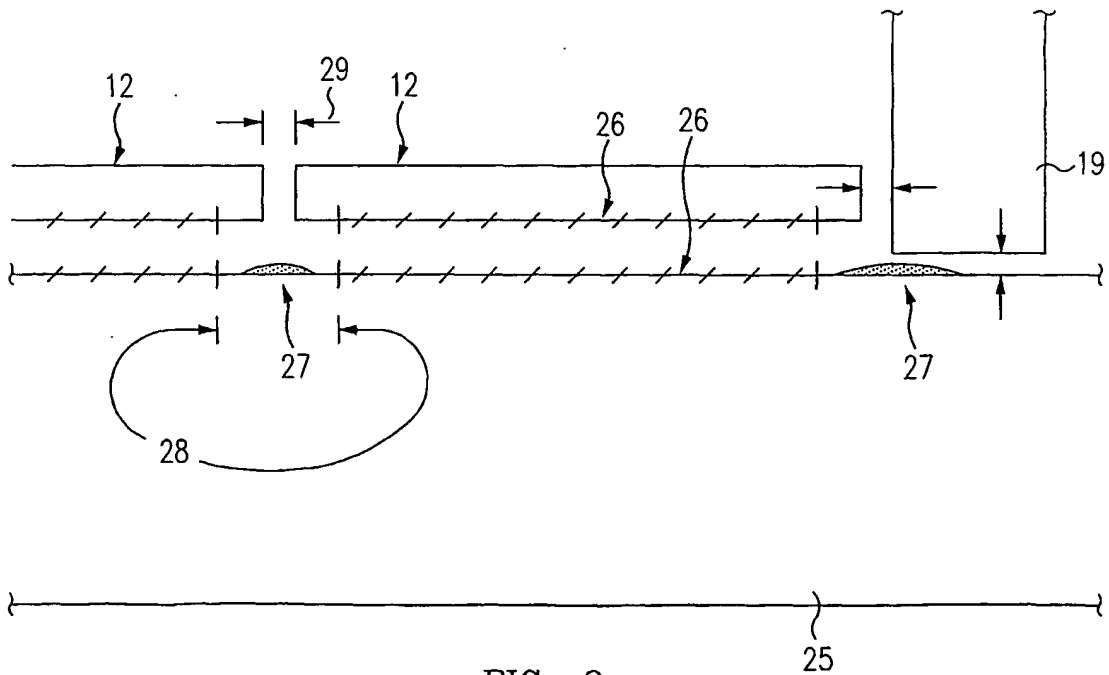


FIG. 3



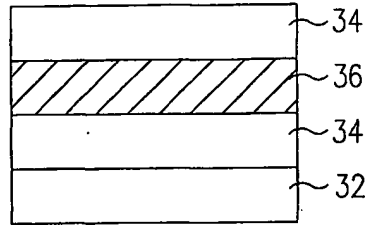


FIG. 4a

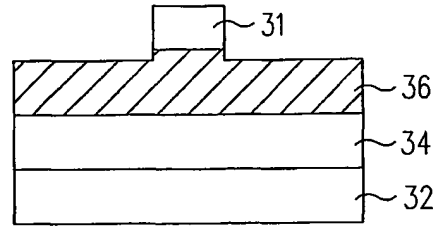


FIG. 4b

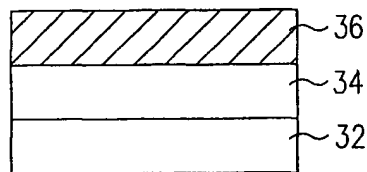


FIG. 5a

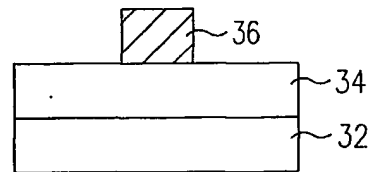


FIG. 5b

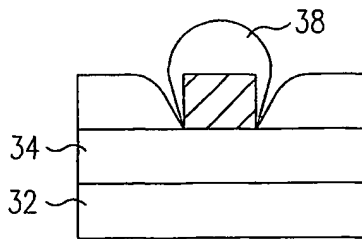


FIG. 5c

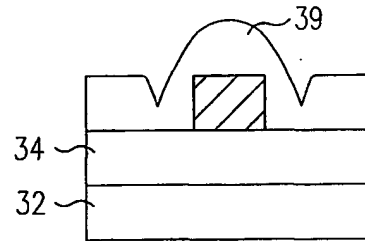


FIG. 5d

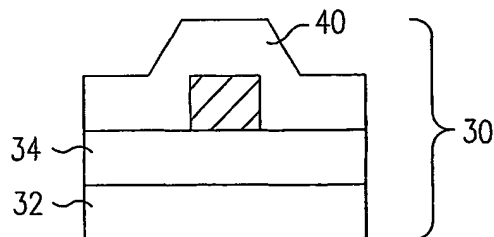


FIG. 5e

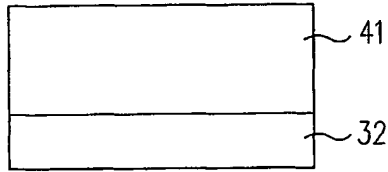


FIG. 6a

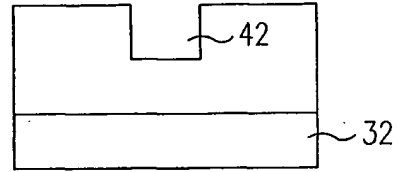


FIG. 6b

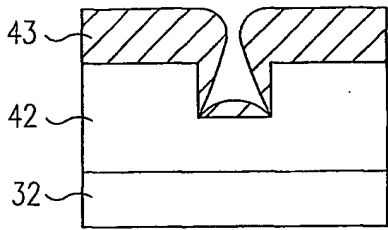


FIG. 6c

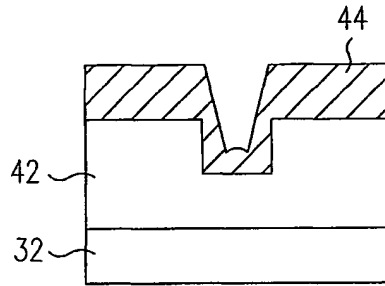


FIG. 6d

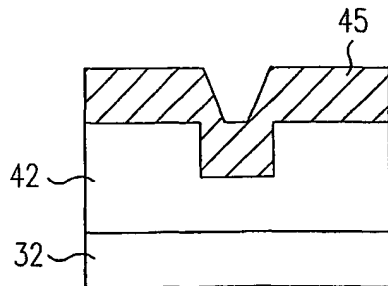


FIG. 6e

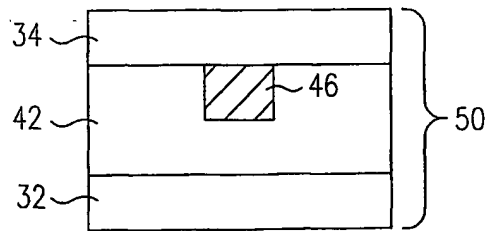


FIG. 6f

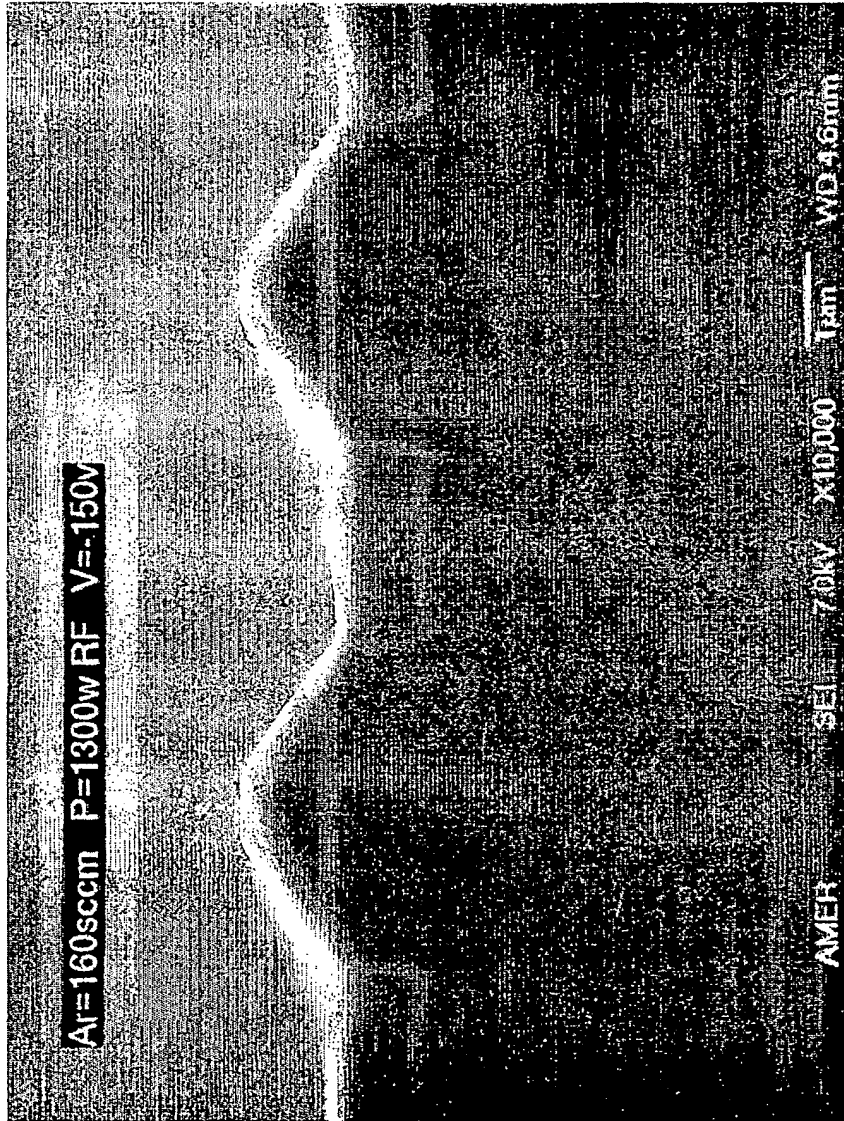


FIG. 7

(12) INTERNATIONAL APPLICATION PUBLISHED UNDER THE PATENT COOPERATION TREATY (PCT)

(19) World Intellectual Property Organization  
International Bureau



(43) International Publication Date  
14 February 2002 (14.02.2002)

PCT

(10) International Publication Number  
WO 02/012932 A3

(51) International Patent Classification<sup>7</sup>: C23C 14/34, 14/35

Court, Morgan Hill, CA 95037 (US). ZHANG, Hongmei; 1330 Rodney Drive, San Jose, CA 95118 (US). PETHE, Rajiv; 3680 Springbrook Avenue, San Jose, CA 95148 (US).

(21) International Application Number: .PCT/US01/22750

(22) International Filing Date: 18 July 2001 (18.07.2001)

(74) Agents: SAXON, Roberta, P. et al.; Skjerven Morrill MacPherson LLP, 25 Metro Drive, Suite 700, San Jose, CA 95110 (US).

(25) Filing Language: English

(26) Publication Language: English

(81) Designated States (national): AE, AG, AL, AM, AT, AU, AZ, BA, BB, BG, BR, BY, BZ, CA, CH, CN, CO, CR, CU, CZ, DE, DK, DM, DZ, EC, EE, ES, FI, GB, GD, GE, GH, GM, HR, HU, ID, IL, IN, IS, JP, KE, KG, KP, KR, KZ, I.C., LK, LR, LS, LT, LU, LV, MA, MD, MG, MK, MN, MW, MX, MZ, NO, NZ, PL, PT, RO, RU, SD, SE, SG, SI, SK, SL, TJ, TM, TR, TT, TZ, UA, UG, UZ, VN, YU, ZA, ZW.

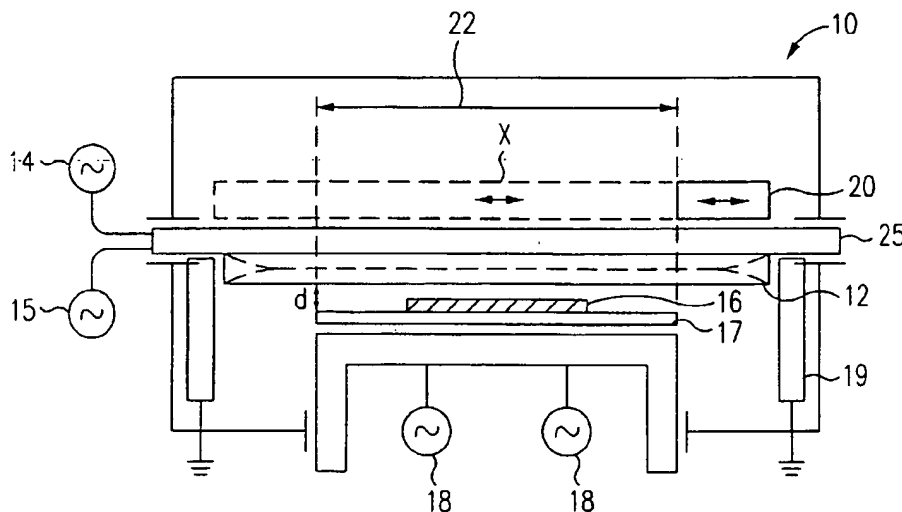
(30) Priority Data:  
09/633,307 7 August 2000 (07.08.2000) US  
09/903,050 10 July 2001 (10.07.2001) US

(71) Applicant: SYMMORPHIX, INC. [US/US]; 1278 Reamwood Avenue, Sunnyvale, CA 94089-2233 (US).

(84) Designated States (regional): ARIPO patent (GH, GM, KE, LS, MW, MZ, SD, SL, SZ, TZ, UG, ZW), Eurasian patent (AM, AZ, BY, KG, KZ, MD, RU, TJ, TM), European patent (AT, BE, CH, CY, DE, DK, ES, FI, FR, GB, GR, IE, IT, LU, MC, NL, PT, SE, TR), OAPI patent (BF, BJ, CF, CG, CI, CM, GA, GN, GW, ML, MR, NE, SN, TD, TG).

[Continued on next page]

(54) Title: METHODS FOR MANUFACTURING PLANAR OPTICAL DEVICES



(57) Abstract: Physical vapor deposition processes provide optical materials with controlled and uniform refractive index that meet the requirements for active and passive planar optical devices. All processes use radio frequency (RF) (14) sputtering with a wide area target (12), larger in area than the substrate (16) on which material is deposited, and uniform plasma conditions which provide uniform target erosion. In addition, a second RF (15) frequency can be applied to the sputtering target and RF power (18) can be applied to the substrate (16) producing substrate bias. Multiple approaches for controlling refractive index are provided. The present RF sputtering methods for material deposition and refractive index control are combined with processes commonly used in semiconductor fabrication to produce planar optical devices such as surface ridge devices, buried ridge devices and buried trench devices. A method for forming composite wide area targets from multiple tiles is also provided.



WO 02/012932 A3



**Published:**

- with international search report
- before the expiration of the time limit for amending the claims and to be republished in the event of receipt of amendments

*For two-letter codes and other abbreviations, refer to the "Guidance Notes on Codes and Abbreviations" appearing at the beginning of each regular issue of the PCT Gazette.*

**(88) Date of publication of the international search report:**

3 October 2002

INTERNATIONAL SEARCH REPORT

International Application No  
PCT/US 01/22750

<p>A. CLASSIFICATION OF SUBJECT MATTER IPC 7 C23C14/34 C23C14/35</p>		
<p>According to International Patent Classification (IPC) or to both national classification and IPC</p>		
<p>B. FIELDS SEARCHED</p>		
<p>Minimum documentation searched (classification system followed by classification symbols) IPC 7 C23C</p>		
<p>Documentation searched other than minimum documentation to the extent that such documents are included in the fields searched</p>		
<p>Electronic data base consulted during the international search (name of data base and, where practical, search terms used) PAJ, WPI Data, IBM-TDB, EPO-Internal</p>		
<p>C. DOCUMENTS CONSIDERED TO BE RELEVANT</p>		
Category *	Citation of document, with indication, where appropriate, of the relevant passages	Relevant to claim No.
X	WO 97 35044 A (MATERIALS RESEARCH CORP) 25 September 1997 (1997-09-25)	1
Y	page 1, line 28 -page 3, line 7; figure 1	2-7, 12-15,19
Y	--- EP 0 510 883 A (AMERICAN TELEPHONE & TELEGRAPH) 28 October 1992 (1992-10-28) cited in the application column 7, line 45 -column 9, line 11	12-15,19
Y	--- PATENT ABSTRACTS OF JAPAN vol. 018, no. 215 (C-1191), 18 April 1994 (1994-04-18) & JP 06 010127 A (ULVAC JAPAN LTD), 18 January 1994 (1994-01-18) abstract --- -/--	2-4
<p><input checked="" type="checkbox"/> Further documents are listed in the continuation of box C.      <input checked="" type="checkbox"/> Patent family members are listed in annex.</p>		
<p>* Special categories of cited documents :</p> <p>"A" document defining the general state of the art which is not considered to be of particular relevance</p> <p>"E" earlier document but published on or after the international filing date</p> <p>"L" document which may throw doubts on priority claim(s) or which is cited to establish the publication date of another citation or other special reason (as specified)</p> <p>"O" document referring to an oral disclosure, use, exhibition or other means</p> <p>"P" document published prior to the international filing date but later than the priority date claimed</p> <p>"T" later document published after the international filing date or priority date and not in conflict with the application but cited to understand the principle or theory underlying the invention</p> <p>"X" document of particular relevance; the claimed invention cannot be considered novel or cannot be considered to involve an inventive step when the document is taken alone</p> <p>"Y" document of particular relevance; the claimed invention cannot be considered to involve an inventive step when the document is combined with one or more other such documents, such combination being obvious to a person skilled in the art.</p> <p>"&amp;" document member of the same patent family</p>		
<p>Date of the actual completion of the international search  25 February 2002</p>		<p>Date of mailing of the international search report  19. 07. 2002</p>
<p>Name and mailing address of the ISA European Patent Office, P.B. 5818 Patentlaan 2 NL - 2280 HV Rijswijk Tel. (+31-70) 340-2040, Tx. 31 651 epo nl, Fax: (+31-70) 340-3016</p>		<p>Authorized officer  EKHULT, H</p>

INTERNATIONAL SEARCH REPORT

International Application No  
PCT/US 01/22750

C.(Continuation) DOCUMENTS CONSIDERED TO BE RELEVANT		
Category *	Citation of document, with indication, where appropriate, of the relevant passages	Relevant to claim No.
Y	US 4 437 966 A (HOPE LAWRENCE L ET AL) 20 March 1984 (1984-03-20) column 2, line 50 -column 4, line 54; figures 2-4	5-7
A	--- EP 0 820 088 A (APPLIED KOMATSU TECHNOLOGY INC) 21 January 1998 (1998-01-21) cited in the application column 1, line 1 -column 4, line 13; figures 1-6 column 6, line 10 - line 19 -----	6,7

# INTERNATIONAL SEARCH REPORT

International application No.  
PCT/US 01/22750

## Box I Observations where certain claims were found unsearchable (Continuation of item 1 of first sheet)

This International Search Report has not been established in respect of certain claims under Article 17(2)(a) for the following reasons:

1.  Claims Nos.:  
because they relate to subject matter not required to be searched by this Authority, namely:
  
2.  Claims Nos.:  
because they relate to parts of the International Application that do not comply with the prescribed requirements to such an extent that no meaningful International Search can be carried out, specifically:
  
3.  Claims Nos.:  
because they are dependent claims and are not drafted in accordance with the second and third sentences of Rule 6.4(a).

## Box II Observations where unity of invention is lacking (Continuation of item 2 of first sheet)

This International Searching Authority found multiple inventions in this international application, as follows:

see additional sheet

1.  As all required additional search fees were timely paid by the applicant, this International Search Report covers all searchable claims.
2.  As all searchable claims could be searched without effort justifying an additional fee, this Authority did not invite payment of any additional fee.
3.  As only some of the required additional search fees were timely paid by the applicant, this International Search Report covers only those claims for which fees were paid, specifically claims Nos.:
4.  No required additional search fees were timely paid by the applicant. Consequently, this International Search Report is restricted to the invention first mentioned in the claims; it is covered by claims Nos.:

1-7, 12-15, 19

Remark on Protest

- The additional search fees were accompanied by the applicant's protest.
- No protest accompanied the payment of additional search fees.



FURTHER INFORMATION CONTINUED FROM PCT/ISA/ 210

This International Searching Authority found multiple (groups of) inventions in this international application, as follows:

1. Claims: 1-7,12-15,19

Sputtering method using a time averaged uniform magnetic field.

2. Claims: 1,8,10,16

Sputtering method using dual frequency.

3. Claims: 1,9,11

Sputtering method using RF substrate bias.

4. Claims: 1,17,18,20-22

Sputtering method using sputtering parameters to influence the refractive index of the coating.

5. Claims: 25-31

Methods for making optical devices.

6. Claims: 1,23,24,32-36

Method for making a composite target.