



US007544276B2

(12) **United States Patent**
Zhang et al.

(10) **Patent No.:** **US 7,544,276 B2**
(45) **Date of Patent:** **Jun. 9, 2009**

(54) **BIASED PULSE DC REACTIVE SPUTTERING OF OXIDE FILMS**

(75) Inventors: **Hongmei Zhang**, San Jose, CA (US); **Mukundan Narasimhan**, San Jose, CA (US); **Ravi B. Mullapudi**, San Jose, CA (US); **Richard E. Demaray**, Portola Valley, CA (US)

(73) Assignee: **SpringWorks, LLC**, Minnetonka, MN (US)

(*) Notice: Subject to any disclaimer, the term of this patent is extended or adjusted under 35 U.S.C. 154(b) by 529 days.

(21) Appl. No.: **11/228,834**

(22) Filed: **Sep. 16, 2005**

(65) **Prior Publication Data**
US 2006/0054496 A1 Mar. 16, 2006

Related U.S. Application Data
(62) Division of application No. 10/101,863, filed on Mar. 16, 2002, now Pat. No. 7,378,356.

(51) **Int. Cl.**
C23C 14/34 (2006.01)

(52) **U.S. Cl.** **204/298.08**; 204/298.2;
204/298.06

(58) **Field of Classification Search** 204/298.2,
204/298.06, 298.08
See application file for complete search history.

(56) **References Cited**
U.S. PATENT DOCUMENTS

3,309,302 A	3/1967	Heil
3,616,403 A	10/1971	Collins et al.
3,850,604 A	11/1974	Klein
4,111,523 A	9/1978	Kaminow et al.
4,437,966 A	3/1984	Hope et al.
4,587,225 A	5/1986	Tsukuma et al.

4,619,680 A	10/1986	Nourshargh et al.
RE32,449 E	6/1987	Claussen
4,710,940 A	12/1987	Sipes, Jr.
4,785,459 A	11/1988	Baer
4,915,810 A	4/1990	Kestigian et al.
4,978,437 A	12/1990	Wirz

(Continued)

FOREIGN PATENT DOCUMENTS

EP 0 510 883 A2 10/1992

(Continued)

OTHER PUBLICATIONS

Affinito et al., "PML/oxide/PML Barrier Layer Performance Differences Arising from Use of UV or Electron Beam Polymerization of the PML Layers," *Thin Solid Films* vol. 308-309, pp. 19-25 (1997).

(Continued)

Primary Examiner—Rodney G McDonald
(74) *Attorney, Agent, or Firm*—Finnegan, Henderson, Farabow, Garrett & Dunner, LLP

(57) **ABSTRACT**

A biased pulse DC reactor for sputtering of oxide films is presented. The biased pulse DC reactor couples pulsed DC at a particular frequency to the target through a filter which filters out the effects of a bias power applied to the substrate, protecting the pulsed DC power supply. Films deposited utilizing the reactor have controllable material properties such as the index of refraction. Optical components such as waveguide amplifiers and multiplexers can be fabricated using processes performed on a reactor according to the present invention.

13 Claims, 27 Drawing Sheets

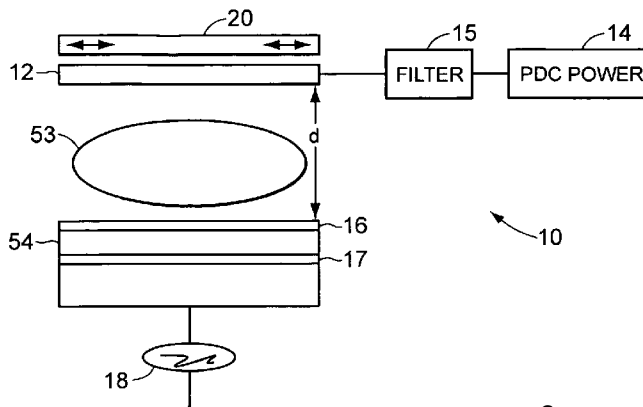

U.S. PATENT DOCUMENTS							
5,085,904	A	2/1992	Deak et al.	6,004,660	A	12/1999	Topolski et al.
5,107,538	A	4/1992	Benton et al.	6,024,844	A	2/2000	Drummond et al.
5,119,460	A	6/1992	Bruce et al.	6,046,081	A	4/2000	Kuo
5,173,271	A	12/1992	Chen et al.	6,051,114	A	4/2000	Yao et al.
5,174,876	A	12/1992	Buchal et al.	6,051,296	A	4/2000	McCaulley et al.
5,196,041	A	3/1993	Tumminelli et al.	6,052,397	A	4/2000	Jeon et al.
5,200,029	A	4/1993	Bruce et al.	6,057,557	A	5/2000	Ichikawa
5,206,925	A	4/1993	Nakazawa et al.	6,058,233	A	5/2000	Dragone
5,225,288	A	7/1993	Beeson et al.	6,071,323	A	6/2000	Kawaguchi
5,237,439	A	8/1993	Misono et al.	6,077,642	A	6/2000	Ogata et al.
5,252,194	A	10/1993	Demaray et al.	6,080,643	A	6/2000	Noguchi et al.
5,287,427	A	2/1994	Atkins et al.	6,088,492	A	7/2000	Kaneko et al.
5,296,089	A	3/1994	Chen et al.	6,093,944	A	7/2000	VanDover
5,303,319	A	4/1994	Ford et al.	6,106,933	A	8/2000	Nagai et al.
5,306,569	A	4/1994	Hiraki	6,117,279	A	9/2000	Smolanoff et al.
5,309,302	A	5/1994	Vollmann	6,146,225	A	11/2000	Sheats et al.
5,338,625	A	8/1994	Bates et al.	6,154,582	A	11/2000	Bazylenko et al.
5,355,089	A	10/1994	Treger	6,157,765	A	12/2000	Bruce et al.
5,381,262	A	1/1995	Arima et al.	6,162,709	A	12/2000	Raoux et al.
5,427,669	A	6/1995	Drummond	6,165,566	A	12/2000	Tropsha
5,457,569	A	10/1995	Liou et al.	6,176,986	B1	1/2001	Watanabe et al.
5,475,528	A	12/1995	LaBorde	6,197,167	B1	3/2001	Tanaka
5,478,456	A	12/1995	Humpal et al.	6,198,217	B1	3/2001	Suzuki et al.
5,483,613	A	1/1996	Bruce et al.	6,204,111	B1	3/2001	Uemoto et al.
5,499,207	A	3/1996	Miki et al.	6,210,544	B1	4/2001	Sasaki
5,512,147	A	4/1996	Bates et al.	6,214,660	B1	4/2001	Uemoto et al.
5,538,796	A	7/1996	Schaffer et al.	6,232,242	B1	5/2001	Hata et al.
5,555,127	A	9/1996	Abdelkader et al.	6,236,793	B1	5/2001	Lawrence et al.
5,563,979	A	10/1996	Bruce et al.	6,242,129	B1	6/2001	Johnson
5,565,071	A	10/1996	Demaray et al.	6,248,291	B1	6/2001	Nakagama et al.
5,569,520	A	10/1996	Bates	6,248,640	B1	6/2001	Nam
5,591,520	A	1/1997	Migliorini et al.	6,261,917	B1	7/2001	Quek et al.
5,597,660	A	1/1997	Bates	6,280,585	B1	8/2001	Obinata et al.
5,603,816	A	2/1997	Demaray et al.	6,281,142	B1	8/2001	Basceri et al.
5,607,560	A	3/1997	Hirabayashi et al.	6,287,986	B1	9/2001	Mihara
5,607,789	A	3/1997	Treger et al.	6,288,835	B1	9/2001	Nilsson et al.
5,612,152	A	3/1997	Bates	6,290,821	B1	9/2001	McLeod
5,613,995	A	3/1997	Bhandarkar et al.	6,290,822	B1	9/2001	Fleming et al.
5,654,054	A	8/1997	Tropsha et al.	6,300,215	B1	10/2001	Shin
5,654,984	A	8/1997	Hershberger et al.	6,302,939	B1	10/2001	Rabin et al.
5,686,360	A	11/1997	Harvey, III et al.	6,306,265	B1	10/2001	Fu et al.
5,689,522	A	11/1997	Beach	6,344,419	B1	2/2002	Forster et al.
5,693,956	A	12/1997	Shi et al.	6,350,353	B2	2/2002	Gopalraja et al.
5,718,813	A	2/1998	Drummond et al.	6,356,694	B1	3/2002	Weber
5,719,976	A	2/1998	Henry et al.	6,358,810	B1	3/2002	Dornfest et al.
5,731,661	A	3/1998	So et al.	6,361,662	B1	3/2002	Chiba et al.
5,738,731	A	4/1998	Shindo et al.	6,365,319	B1	4/2002	Heath et al.
5,755,938	A	5/1998	Fukui et al.	6,391,166	B1	5/2002	Wang
5,757,126	A	5/1998	Harvey, III et al.	6,409,965	B1	6/2002	Nagata et al.
5,762,768	A	6/1998	Goy et al.	6,413,382	B1	7/2002	Wang et al.
5,771,562	A	6/1998	Harvey, III et al.	6,413,645	B1	7/2002	Graff et al.
5,792,550	A	8/1998	Phillips et al.	6,416,598	B1	7/2002	Sircar
5,811,177	A	9/1998	Shi et al.	6,423,776	B1	7/2002	Akkapeddi et al.
5,830,330	A	11/1998	Lantsman	6,433,380	B2	8/2002	Shin
5,831,262	A	11/1998	Greywall et al.	6,444,750	B1	9/2002	Touhsaent
5,841,931	A	11/1998	Foresi et al.	6,452,717	B1	9/2002	Endo
5,847,865	A	12/1998	Gopinath et al.	6,488,822	B1	12/2002	Moslehi
5,849,163	A	12/1998	Ichikawa et al.	6,506,289	B2	1/2003	Demaray et al.
5,853,830	A	12/1998	McCaulley et al.	6,511,615	B1	1/2003	Dawes et al.
5,855,744	A	1/1999	Halsey et al.	6,533,907	B2	3/2003	Demaray et al.
5,870,273	A	2/1999	Sogabe et al.	6,537,428	B1	3/2003	Xiong et al.
5,882,946	A	3/1999	Otani	6,563,998	B1	5/2003	Farah et al.
5,900,057	A	5/1999	Buchal et al.	6,576,546	B2	6/2003	Gilbert et al.
5,930,584	A	7/1999	Sun et al.	6,602,338	B2	8/2003	Chen et al.
5,942,089	A	8/1999	Sproul et al.	6,605,228	B1	8/2003	Kawaguchi et al.
5,948,215	A	9/1999	Lantsman	6,615,614	B1	9/2003	Makikawa et al.
5,952,778	A	9/1999	Haskal et al.	6,632,563	B1	10/2003	Krasnov et al.
5,961,682	A	10/1999	Lee et al.	6,673,716	B1	1/2004	D'Couto et al.
5,966,491	A	10/1999	DiGiovanni	6,750,156	B2	6/2004	Le et al.
				6,760,520	B1	7/2004	Medin et al.
				6,768,855	B1	7/2004	Bakke et al.

6,884,327	B2	4/2005	Pan et al.
7,262,131	B2	8/2007	Narasimhan et al.
2001/0027159	A1	10/2001	Kaneyoshi
2001/0031122	A1	10/2001	Lackritz et al.
2001/0034106	A1	10/2001	Moise et al.
2001/0041460	A1	11/2001	Wiggins
2002/0033330	A1	3/2002	Demaray et al.
2002/0076133	A1	6/2002	Li et al.
2002/0106297	A1	8/2002	Ueno et al.
2002/0134671	A1	9/2002	Demaray et al.
2002/0170821	A1	11/2002	Sandlin et al.
2002/0191916	A1	12/2002	Frish et al.
2003/0019326	A1	1/2003	Han et al.
2003/0022487	A1	1/2003	Yoon et al.
2003/0042131	A1	3/2003	Johnson
2003/0044118	A1	3/2003	Zhou et al.
2003/0063883	A1	4/2003	Demaray et al.
2003/0077914	A1	4/2003	Le et al.
2003/0079838	A1	5/2003	Brcka
2003/0097858	A1	5/2003	Strohhofer et al.
2003/0127319	A1	7/2003	Demaray et al.
2003/0134054	A1	7/2003	Demaray et al.
2003/0141186	A1	7/2003	Wang et al.
2003/0143853	A1	7/2003	Celii et al.
2003/0173207	A1	9/2003	Zhang et al.
2003/0173208	A1	9/2003	Pan et al.
2003/0174391	A1	9/2003	Pan et al.
2003/0175142	A1	9/2003	Milonopoulou et al.
2003/0185266	A1	10/2003	Henrichs
2004/0077161	A1	4/2004	Chen et al.
2004/0105644	A1	6/2004	Dawes
2004/0259305	A1	12/2004	Demaray et al.
2005/0000794	A1	1/2005	Demaray et al.
2005/0006768	A1	1/2005	Narasimhan et al.
2005/0048802	A1	3/2005	Zhang et al.
2005/0175287	A1	8/2005	Pan et al.
2005/0183946	A1	8/2005	Pan et al.
2006/0057283	A1	3/2006	Zhang et al.
2006/0057304	A1	3/2006	Zhang et al.
2006/0071592	A1	4/2006	Narasimhan et al.
2006/0134522	A1	6/2006	Zhang et al.
2007/0053139	A1	3/2007	Zhang et al.

FOREIGN PATENT DOCUMENTS

EP	0 652 308	A2	10/1994
EP	0 639 655	A1	2/1995
EP	0 820 088	A2	1/1998
EP	0 867 985	B1	9/1998
EP	1068899	A1	1/2001
EP	1 092 689	A1	4/2001
EP	1 189 080	A2	3/2002
JP	2-054764	A2	2/1990
JP	6-010127	A	1/1994
JP	6-100333	A	12/1994
JP	7-224379	A	8/1995
JP	7-233469	A	9/1995
KR	2002-26187		4/2002
WO	WO 96/23085		8/1996
WO	WO 97/35044		9/1997
WO	WO 00/21898	A1	4/2000
WO	WO 00/22742	A2	4/2000
WO	WO 00/36665	A1	6/2000
WO	WO 01/82297	A1	11/2001
WO	WO 02/12932	A2	2/2002
WO	WO 2004/021532	A1	3/2004
WO	WO 2004/077519	A2	9/2004
WO	WO 2004/106581	A2	12/2004

WO WO 2007/027535 3/2007

OTHER PUBLICATIONS

- Affinito et al., "Polymer-Oxide Transparent Barrier Layers," Society of Vacuum Coaters, 39th Ann. Technical Conference Proceedings, May 5-10, 1996, Philadelphia, PA, pp. 392-397 (1996).
- Alder, T. et al., "High-Efficiency Fiber-to-Chip Coupling Using Low-Loss Tapered Single-Mode Fiber," *IEEE Photonics Technology Letters*, 12(8):1016-1018 (2000).
- Almeida, Wilson R. et al., "Nanotaper for compact mode conversion," *Optics Letters*, 28(15):1302-1304 (2003).
- Asghari et al., "ASOC—A Manufacturing Integrated Optics Technology," Part of the SPIE Conference on Integrated Optics Devices III, vol. 3620, pp. 252-262 (Jan. 1999).
- Barbier et al., "Amplifying Four-Wavelength Combiner, Based on Erbium/Erterbium-Doped Waveguide Amplifiers and Integrated Splitters", *IEEE Photonics Technology Letters*, vol. 9, pp. 315-317, 1997, 4 pages.
- Barbier, Denis, "Performances and potential applications of erbium doped planar waveguide amplifiers and lasers," *GeO*, pp. 58-6 (date unknown).
- Beach R.J., "Theory and optimization of lens ducts," *Applied Optics*, 35:12:2005-15 (1996).
- Belkind et al., "Using pulsed direct current power for reactive sputtering of Al₂O₃," *J. Vac. Sci. Technol. A* 17(4), pp. 1934-1940 (Jul. 1999).
- Bestwick, T., "ASOC silicon integrated optics technology," Part of the SPIE Conferences on Photonics Packaging and Integration, SPIE vol. 3631, pp. 182-190 (Jan. 1999).
- Borsella et al., "Structural incorporation of silver insoda-lime glass by the ion-exchange process: a photoluminescence spectroscopy study", *Applied Physics A* 71, pp. 125-132 (2000).
- Byer et al., "Nonlinear Optics and Solid-state Lasers," *IEEE Journal on Selected Topics in Quantum Electronics*, vol. 6, No. 6, pp. 921-929 (Nov. 2000).
- Campbell et al., "Titanium dioxide (TiO₂)-based gate insulators," *IBM J. Res. Develop.* 43(3), 383-391, (May 1999).
- Chang, C.Y. (edited by), "ULSI Technology," The McGraw-Hill Companies, Inc., New York, 1996, Chapter 4, pp. 169-170, 226-231 (1996).
- Chen et al. "Development of Supported Bifunctional Electrocatalysts for Unitized Regenerative Fuel Cells," *Journal of the Electrochemical Society*, 149(8), A1092-99, (2002).
- Choi et al., "Er-Al-codoped silicate planar light waveguide-type amplifier fabricated by radio-frequency sputtering," *Optics Letters*, vol. 25, No. 4, pp. 263-265 (Feb. 15, 2000).
- Cooksey et al. "Predicting Permeability & Transmission Rate for Multilayer Materials," *Foodtechnology*, vol. 53, No. 9, pp. 60-63 (Sep. 1999).
- Crowder, et al., "Low-Temperature Single-Crystal Si TFT's Fabricated on Si Films Processed via Sequential Lateral Solidification," *IEEE*, vol. 19, No. 8 (Aug. 1998), pp. 306-308.
- Delavaux et al., "Integrated optics erbium ytterbium amplifier system in 10 Gb/s fiber transmission experiment", 22nd European Conference on Optical Communication—ECOC' 96, Oslo, 4 pages (1996).
- Distributed Energy Resources: Fuel Cells, Projects, http://www.eere.energy.gov/der/fuel_cells/projects.html (2003).
- DuPont Teijin Films, Mylar 200 SBL 300, Product Information (2000).
- Electrometals Technologies Limited, Financial Report for the year 2002, Corporate Directory, Chairman's Review, Review of Operations (2002).
- E-Tek website: FAQ, Inside E-Tek, E-Tek News, Products: <http://www.etek-inc.com/> (2003).
- Flytzanis et al, "nonlinear Optics in Composite Materials," E. Wolf, Progress in Optics XXIX (c) Elsevier Science Publishers B.V., pp. 323-425 (1991).

- Fujii et al., "1.54 mm photoluminescence of Er³⁺ doped into SiO₂ films containing Si nanocrystals: Evidence for energy transfer from Si nanocrystals for Er³⁺", *Appl. Phys. Lett.* 71 (9), pp. 1198-1200 (Sep. 1997).
- Garcia, C. "Size Dependence of Lifetime and Absorption Cross Section of Si Nanocrystals Embedded in SiO₂," *Appl. Phys. Lett.*, vol. 82, No. 10, pp. 1595-1597 (Mar. 2003).
- Goossens et al., "Sensitization of TiO₂ with p-type semiconductor polymers," Delft Interfaculty Research Center, Delft University of Technology Laboratory of Inorganic Chemistry, The Netherlands (1998).
- Greene et al., "Morphological and electrical properties of rf sputtered Y2O3-doped ZrO2 thin films," *J. Vac. Sci. Technol.*, vol. 13, No. 1 (Jan./Feb. 1976), pp. 72-75.
- Han, Hak-Seung et al. "Optical Gain at 1.54 m in Erbium-Doped Silicon Nanocluster Sensitized Waveguide," *Appl. Phys. Lett.*, vol. 79, No. 27, pp. 4568-4570 (Dec. 2001).
- Hayakawa et al., "Enhanced fluorescence from Eu³⁺ owing to surface plasma oscillation of silver particles in glass", *Journal of Non-Crystalline Solids*, vol. 259, pp. 16-22 (1999).
- Hayakawa et al., "Field enhancement effect of small Ag particles on the fluorescence from Eu³⁺-doped SiO₂ glass", *Appl. Phys. Lett.*, vol. 74, No. 11, pp. 1513-1515 (Mar. 1999).
- Hayfield, P.C.S., "Development of a New Material-Monolithic Ti4O7 Ebonix Ceramic," Royal Society Chemistry, (2002).
- Hehlen et al. "Spectroscopic Properties of Er³⁺- and Yb³⁺-doped Soda-Lime Silicate and Aluminosilicate Glasses," *Physical Review B*, vol. 56, No. 15, pp. 9302-9318 (Oct. 1997).
- Hehlen et al. "Uniform Upconversion in High-Concentration Er³⁺-doped Soda Lime Silicate and Aluminosilicate Glasses," *Optics Letters*, vol. 22, No. 11, pp. 772-774 (Jun. 1997).
- Horst et al., "Compact, Tunable Optical Devices in Silicon-Oxynitride Wave Guide Technology," IBM Research Division, 3 pages (1999).
- Hubner, J. and Guldborg-Kjaer, S., "Planar Er-and Yb-Doped Amplifiers and Lasers," COM Technical University of Denmark, 10.sup.th European Conf. On Integrated Optics, Session WeB2, pp. 71-74 (2001).
- Hwang, Man-Soo et al., "The effect of pulsed magnetron sputtering on the properties of indium tin oxide thin films," Elsevier Science B.V., p. 29-33, (2003).
- Im, et al. "Controlled Super-lateral Growth of Si Films for Microstructural Manipulation and Optimization," Materials Science Program (1998), pp. 603-617.
- Im, et al., "Crystalline Si Films for Integrated Active-Matrix LiquidCrystal Displays," *MRS Bulletin* (Mar. 1996), pp. 39-48.
- Im, et al., "Single-crystal Si films for thin-film transistor devices," American Institute of Physics (1997), pp. 3434-3436.
- Itoh, M. et al., "Large reduction of singlemode-fibre coupling loss in 1.5% delta planar lightwave circuits using spot-size converters," *Electronics Letters*, 38(2):72-74 (2002).
- Jackson et al. "An Accurate Compact EDFA Model," Dept. of Electrical and Computer Engineering, University of BC (date unknown).
- Janssen et al. "Photoinduced electron transfer from conjugated polymers onto nanocrystalline TiO₂," Eindhoven University of Technology, The Netherlands (date unknown).
- Johnson, J.E. et al., "Monolithically Integrated Semiconductor Optical Amplifier and Electroabsorption Modulator with Dual-Waveguide Spot-Size Converter Input," *IEEE Journal of Selected Topics in Quantum Electronics*, 6(1):19-25, (2000).
- Jonsson L.B. et al. "Frequency response in pulsed DC reactive sputtering processes," *Thin Solid Films*, vol. 365, pp. 43-48 (2000).
- Kato et al., "Recent progress on PLC hybrid integration," Part of the SPIE Conference on Optoelectronic Integrated Circuits III, SPIE. vol. 3631, pp. 28-36 (Jan. 1999).
- Kato, Kuniharu et al., "PLC Hybrid Integration Technology and Its Application to Photonic Components," *IEEE Journal of Selected Topics in Quantum Electronics*, 6(1):4-13 (2000).
- Kelly et al., "Reactive pulsed magnetron sputtering process for alumina films," *J. Vac. Sci. Technol. A* 18(6), pp. 2890-2896 (Nov. 2000).
- Kelly et al., "Control of the structure and properties of aluminum Kik, P.G. et al. "Gain Limiting Processes in Er-doped Si Nanocrystal Waveguides in SiO₂," *J. Appl. Phys.*, vol. 91, No. 1, pp. 534-536 (Jan. 1, 2002).
- Kim et al. "Frequency-dependent pulsed direct current magnetron sputtering of titanium oxide films," *J. Vac. Sci. Technol. A* 19(2); 429-434 (Mar. 2001).
- Kim et al. "Mixture Behaviour and Microwave Dielectric Properties in the Low-fired TiO₂-CuO System," *Jpn. J. Appl. Phys.*, 39, 2696-2700, (2000).
- Ladouceur, F. et al., "8.8 Evaluation of Results", *Silica-based Buried Channel Waveguides and Devices.*, Chapman & Hall, London, pp. 98-99 (1996).
- Ladouceur, F. et al., "Effect of side wall roughness in buried channel waveguides," *IEEE Proc.*, vol. 141, pp. 242-248 (Aug. 1994).
- Lamb, William B., "Designing Nonfoil Containing Skins for VIP Applications," DuPont VIA Symposium Presentation, (1999).
- Lamb, William et al. "Designing Non-Foil Containing Skins for Vacuum InsulationPanel (VIP) Applications," *Vuoto*, vol. XXVIII, No. 1-2—Gennaio-Giugno 1999, pp. 55-58 (1999).
- Lange et al., "High Gain Ultra-Short Length Phosphate glass Erbium-Doped Fiber Amplifier Material", OSA Optical Fiber Communications (OFC), 3 pages (2002).
- Laporta et al., "Diode-pumped cw bulk Er: Yb: glass laser", 1952 Optics Letters/vol. 16, No. 24/Dec. 15, 6 pages (1991).
- Laurent-Lund, C. et al., "PECVD Grown Multiple Core Planar Waveguides with Extremely Low Interface Reflections and Losses," *IEEE Photonics Technology Letters*, vol. 10, No. 10, pp. 1431-1433 (Oct. 1998).
- Lee et al., "Effect of size and roughness on light transmission in a S/SiO₂ waveguide: Experiments and model," Department of Materials Science and Engineering, Massachusetts Institute of Technology, (Jul. 12, 2000).
- Lee et al. "Effects of interfacial layer growth on the electrical characteristics of thin titanium oxide films on silicon," *Applied Physics Letters*, 74(21), 3143-3145, (May 1999).
- Love, J.D. et al., "Quantifying Loss Minimisation in Single-Mode Fibre Tapers," *Electronics Letters*, 22(17):912-914, (1986).
- Mardare et al. "On the structure of Titanium Oxide Thin Films," *Analele Stiintifice Ale Universitatii AL. I. Cuza IASA*, vol. XLV-XLVI, 201-208 (1999).
- Marques, P.V.S. et al., "Planar Silica-on-Silicon Waveguide Lasers Based in Two Layer Core Devices," 10.sup.th European Conference on Integrated Optics, Session WeB2, pp. 79-82 (2001).
- Meijerink et al, Luminescence of AG⁺ In Crystalline and Glassy SrB₄O₇, *Journal of Physics and Chemistry of Solids*, vol. 54, No. 8, pp. 901-906, (1993).
- Mesnaoui et al., "Spectroscopic properties of AG⁺ ions in phosphate glasses of NaPO₃-AgPO₃ system", *European Journal of Solid State and Inorganic Chemistry*, vol. 29, pp. 1001-1013, 14 pages (1992).
- Mitomi, O. et al., Design of a Single-Mode Tapered Waveguide for Low-Loss Chip-to-Fiber Coupling., *IEEE Journal of Quantum Electronics*, 30(8):1787-1793, (1994).
- Mizuno et al. "Temperature dependence of oxide decomposition on titanium surfaces in UHV," submitted to *Journal of Vacuum Science and Technology*, (Oct. 28, 2001).
- Ohkubo et al., "Polarization-Insensitive Arrayed-Waveguide Grating Using Pure Si₂ Cladding," Fifth Optoelectronics and Communication Conference (OECC 2000) Technical Digest, 2 pages (Jul. 2000).
- Ohmi et al., "Rare earth metal oxides for high-K gate insulator," Tokyo Institute of Technology,(date unknown).
- Ohtsuki et al., "Gain Characteristics of a high concentration Er³⁺-doped phosphate glass waveguide", *J. Appl. Phys.* 78(6), pp. 3617-3621 (1995).
- Ono et al., "Design of a Low-loss Y-branch Optical Waveguide," Fifth Optoelectronic and Communications Conference (OECC 2000) Technical Digest, 2 pages (Jul. 2000).
- Padmini et al. "Realization of High-Tunability Barium Strontium Titanate Thin Films by RF Magnetron Sputtering," College of Engineering, University of California, Santa Barbara. (date unknown).
- Pan et al., "Planar Er³⁺-doped aluminosilicate waveguide amplifier

- Peters et al., "Formation mechanism of silver nanocrystals made by ion irradiation of Na⁺—Ag⁺ ion-exchanged sodalime silicate glass", Nuclear Instruments and Methods in Physics Research B 168, pp. 237-244 (2000).
- Rajarajan, M. et al., et al., "Numerical Study of Spot-Size Expanders for an Efficient OEIC to SMF Coupling," *IEEE Photonics Technology Letters*, 10(8):1082-1084, (1998).
- Ramaswamy et al., "Ion-Exchanged Glass Waveguides: A Review", *Journal of Lightwave Technology*, vol. 6, No. 6, pp. 984-1001 (1988).
- Roberts et al., "The Photoluminescence of Erbium-doped Silicon Monoxide," Department of Electronics and Computer Science, 7 pages (Jun. 1996).
- Sanyo Vacuum Industries Co., Ltd. Products Info, TiO₂, (2003). <http://www.sanyovac.co.jp/Englishweb/products/ETiO2.htm>.
- Schermer, R. et al., "Investigation of Mesa Dielectric Waveguides," Proceedings of the OSA Integrated Photonics Research Topical Meeting and Exhibit, Paper No. IWB3 (Jun. 2001).
- Schiller et al. "PVD Coating of Plastic Webs and Sheets with High Rates on Large Areas," European Materials Research Society 1999 Spring Meeting, Jun. 1-4, 1999, Strasbourg, France (1999).
- Second International Symposium of Polymer Surface Modification: Relevance to Adhesion, Preliminary Program (1999).
- Seventh International Conference on TiO₂ Photocatalysis: Fundamentals & Applications, Toronto, Ontario, Canada, Final Program (Nov. 7-21, 2002).
- Sewell, P. et al., "Rib Waveguide Spot-Size Transformers: Modal Properties," *Journal of Lightwave Technology*, 17(5):848-856, (1999).
- Shaw et al. "Use of Vapor Deposited Acrlate Coatings to Improve the Barrier Properties of Metallized Film," Society of Vacuum Coaters 505/856-7168, 37th Annual Technical Conference Proceedings, pp. 240-244 (1994).
- Shin et al. "Dielectric and Electrical Properties of Sputter Grown (Ba,Sr)TiO₃ Thin Films," *J. Appl. Phys.*, vol. 86, No. 1, pp. 506-513 (Jul. 1999).
- Shmulovich et al., "Recent progress in Erbium-doped waveguide amplifiers," Bell Laboratories, 3 pages (1999).
- Slooff et al., "Optical properties of Erbium-doped organic polydentate cage complexes", *J. Appl. Phys.* 83, pp. 497-503 (Jan. 1998).
- Smith, R.E., "Reduced Coupling Loss Using a Tapered-Rib Adiabatic-Following Fiber Coupler," *IEEE Photonics Technology Letters*, 8(8):1052-1054 (1996).
- Strohhofer, et al. "Energy transfer to Er³⁺ in Ag ion-exchanged glass", FOM Institute for Atomic and Molecular Physics, 10 pages (date unknown).
- Sugiyama et al., "Gas Permeation Through the Pinholes of Plastic Film Laminated with Aluminum Foil," *Vuoto*, vol. XXVIII, N. 1-2—Gennaio-Guigno (1999).
- Tervonen, A., "Challenges and opportunities for integrated optics in optical networks," Part of the SPIE Conference in Integrated Optics Devices III, SPIE vol. 3620, pp. 2-11 (Jan. 1999).
- Ting et al., "Study of planarized sputter-deposited SiO₂," *J. Vac. Sci. Technol.*, 15(3) pp. 1105-1112 (May/June 1978).
- Treichel et al., "The influence of pulsed magnetron sputtering on topography and crystallinity of TiO₂ films on glass," *Space and Coatings Technology*, vol. 123, pp. 268-272 (2000).
- Tukamoto, H. et al., "Electronic Conductivity of LiCoO₅ and Its Enhancement by Magnesium Doping," *J. Electrochem. Soc.*, vol. 44, No. 9, pp. 3164-3168 (Sep. 1997).
- Van Dover, R.B. "Amorphous Lanthanide-Doped TiO_x Dielectric Films," *Appl. Phys. Lett.*, vol. 74, No. 20, pp. 3041-3043 (May 1999).
- Viljanen et al., "Planar Optical Coupling Elements for Multimode Fibers with Two-Step Ion Migration Process", *Applied Physics*, 24, No. 1, pp. 61-63 (Jan. 1981).
- Villegas et al., "Optical spectroscopy of a soda lime glass exchanged with silver", *Physics and Chemistry of Glasses* 37(6), pp. 248-253 (1996).
- Von Rottkay et al. "Influence of stoichiometry on electrochromic Westlinder et al. "Simulation and Dielectric Characterization of Reactive dc Magnetron Cosputtered (Ta₂O₅)_{1-x}(TiO₂)_x Thin Films," *J. Vac. Sci. Technol. B*, vol. 20, No. 3, pp. 855-861 (May/June 2002).
- Wilkes, Kenneth T. "Gas Permeation Through Vacuum Barrier Films and its Effect on VIP Thermal Performance," Vacuum Insulation Panel Symp., Baltimore, Maryland, (May 3, 1999).
- Yanagawa, H. et al., "Index-and-Dimensional Taper and Its Application to Photonic Devices," *Journal of Lightwave Technology*, 10(5):587-591 (1992).
- Yoshikawa, K. et al., "Spray formed aluminium alloys for sputtering targets," *Power Metallurgy*, vol. 43, No. 3 (2000).
- Zhang, Hongmei et al. "High Dielectric Strength, High k TiO₂ Films by Pulsed DC, Reactive Sputter Deposition," (2001).
- Office Action issued on Sep. 27, 2004 in U.S. Appl. No. 10/291,179.
- Response to Office Action filed on Mar. 14, 2005 in U.S. Appl. No. 10/291,179.
- Office Action issued on Jun. 15, 2005 in U.S. Appl. No. 10/291,179.
- Office Action issued on May 2, 2002 in U.S. Patent No. 6,533,907.
- Response to Office Action filed on Sep. 3, 2002 in U.S. Patent No. 6,533,907.
- Office Action issued on Feb. 12, 2004 in U.S. Appl. No. 09/903,081.
- Response to Office Action filed on Aug. 10, 2004 in U.S. Appl. No. 09/903,081.
- Office Action issued on Sep. 10, 2004 in U.S. Appl. No. 09/903,081.
- Amendment/RCE filed on Aug. 10, 2004 in U.S. Appl. No. 09/903,081.
- Office Action issued on Mar. 17, 2005 in U.S. Appl. No. 09/903,081.
- Response to Office Action issued on Jun. 17, 2005 in U.S. Appl. No. 09/903,081.
- Office Action issued on Jul. 8, 2005 in U.S. Appl. No. 09/903,081.
- Office Action issued on May 14, 2003 in U.S. Appl. No. 10/101,492.
- Response to Office Action filed on Aug. 14, 2003 in U.S. Appl. No. 10/101,492.
- Office Action issued on Sep. 3, 2003 in U.S. Appl. No. 10/101,492.
- Response to Office Action filed on Mar. 3, 2004 in U.S. Appl. No. 10/101,492.
- Office Action issued on Feb. 24, 2004 in U.S. Appl. No. 10/101,863.
- Response to Office Action filed on Jul. 23, 2004 in U.S. Appl. No. 10/101,863.
- Office Action issued on Oct. 6, 2004 in U.S. Appl. No. 10/101,863.
- Office Action dated Jan. 13, 2005, received in U.S. Appl. No. 10/101,863.
- Response to office Action filed on Jun. 10, 2005 in U.S. Appl. No. 10/101,863.
- Office Action issued on Aug. 4, 2005, in U.S. Appl. No. 10/101,863.
- Office Action dated Mar. 25, 2005, received in U.S. Appl. No. 10/954,182.
- Office Action issued on Oct. 22, 2003 in U.S. Appl. No. 10/101,341.
- Response to Office Action filed on Feb. 23, 2004 in U.S. Appl. No. 10/101,341.
- Office Action issued on Jun. 10, 2004 in U.S. Appl. No. 10/101,341.
- Response to Office Action filed on Dec. 8, 2004 in U.S. Appl. No. 10/101,341.
- Office Action issued on May 4, 2004 in U.S. Appl. No. 10/101,493.
- International Search Report issued on Nov. 21, 2003 in PCT/US03/24809.
- Office Action issued on Mar. 14, 2005 in U.S. Appl. No. 10/789,953.
- International Search Report issued on Oct. 11, 2004 in PCT/US2004/005531.
- Written Opinion issued on Oct. 11, 2004 in PCT/US2004/005531.
- Office Action issued on Mar. 24, 2005 in U.S. Appl. No. 10/851,542.
- Pct international Search Report of Application No. PCT/US2004/014524 dated Mar. 2, 2005.
- PCT International Search Report of Application No. PCT/US2004/014523 dated Jan. 17, 2005.
- Belkind, A. et al., "Pulsed-DC Reactive Sputtering of Dielectrics: Pulsing Parameter Effects," 43rd Annual Technical Conference Proceedings-Denver: 86-90 (Apr. 15-20, 2000).
- Scholl, R., "Power Supplies for Pulsed Plasma Technologies: State-Of-The-Art And Outlook," *Advances Energy Industries, Inc.*, pp. 1-8 (1999).

Explore Litigation Insights

Docket Alarm provides insights to develop a more informed litigation strategy and the peace of mind of knowing you're on top of things.

Real-Time Litigation Alerts



Keep your litigation team up-to-date with **real-time alerts** and advanced team management tools built for the enterprise, all while greatly reducing PACER spend.

Our comprehensive service means we can handle Federal, State, and Administrative courts across the country.

Advanced Docket Research



With over 230 million records, Docket Alarm's cloud-native docket research platform finds what other services can't. Coverage includes Federal, State, plus PTAB, TTAB, ITC and NLRB decisions, all in one place.

Identify arguments that have been successful in the past with full text, pinpoint searching. Link to case law cited within any court document via Fastcase.

Analytics At Your Fingertips



Learn what happened the last time a particular judge, opposing counsel or company faced cases similar to yours.

Advanced out-of-the-box PTAB and TTAB analytics are always at your fingertips.

API

Docket Alarm offers a powerful API (application programming interface) to developers that want to integrate case filings into their apps.

LAW FIRMS

Build custom dashboards for your attorneys and clients with live data direct from the court.

Automate many repetitive legal tasks like conflict checks, document management, and marketing.

FINANCIAL INSTITUTIONS

Litigation and bankruptcy checks for companies and debtors.

E-DISCOVERY AND LEGAL VENDORS

Sync your system to PACER to automate legal marketing.