

## EXAMPLE 5: RF SPUTTER DEPOSITION OF SILICA WITH SUBSTRATE BIAS

An AKT 4300 series PVD production reactor (Applied Komatsu Technology, Santa Clara, CA) modified to accept custom ceramic tile targets and modified to induce a voltage on the substrate was used to deposit silica on planar and patterned 100 mm silicon wafers.

5 A wide area target of dimension 750 x 870 mm was fabricated as described in Example 1. The wafers were placed in the center of a Corning code 1739 glass carrier sheet opposite the target. The reactor was operated in the diode sputtering mode, without magnetic enhancement, at a high frequency RF power of 2500 W and an induced voltage of -400V. A bias voltage of -125 V at 2 MHz and 250 W was induced on the substrate. An argon gas  
10 flow rate of 160 sccm was used.

Average surface roughness of a 0.75  $\mu\text{m}$  thick film deposited on a planar wafer, determined as in Example 4, was 0.14 nm. The refractive index determined as the average of measurements at 12 points on the surface was 1.4622 with a uniformity, defined as the difference of the minimum and maximum values divided by twice the average, of  $3.4 \times 10^{-5}$   
15 percent. To the best knowledge of the inventors, the exceptional uniformity reported here exceeds that of any vacuum deposited film reported previously.

FIG. 7 shows an SEM image of a silica film deposited over a patterned substrate. The trenches in the patterned substrate are seen to be completely and uniformly filled and the ridges are uniformly covered. The top surface of the layer overlying the ridges is flat  
20 and the sloping sides of the layer overlying the ridges are nominally at 45 degree angles. All of the foregoing geometric features are characteristic of bias sputtering deposition. As reported above, for trench features with unit aspect ratio, the maximum thickness at the bottom of the trench of films deposited by conventional RF sputtering is less than about 10-20%.

25 Although the present invention has been described in terms of specific materials and conditions, the description is only an example of the invention's application. Various adaptations and modifications of the processes disclosed are contemplated within the scope of the invention as defined by the following claims.

## CLAIMS

We claim:

1. A method of making a material layer used in forming planar optical devices, the method comprising:
  - 5 positioning a substrate opposite a planar target, the target having an area larger than the area of the substrate; and
  - applying radiofrequency power at a first frequency to the target in the presence of a gas, under a condition wherein a central portion of the target overlying the substrate is exposed to a uniform plasma condition, whereby a
  - 10 material layer is formed on the substrate.
2. The method of Claim 1 wherein the uniform plasma condition is created by applying a time-averaged uniform magnetic field.
- 15 3. The method of Claim 2 wherein the uniform magnetic field is applied by moving a magnet positioned proximate to the target across the target in a plane parallel to the plane of the target.
4. The method of Claim 3 wherein moving a magnet across the target is
- 20 moving a magnet in a first direction, the magnet extending beyond the target, in a second direction perpendicular to the first direction.
5. The method of Claim 1 wherein the area of the planar target is at least 1.5 times greater than the area of the substrate.
- 25 6. The method of Claim 5 wherein the material layer deposited on the substrate has a thickness nonuniformity of less than 5 percent.
7. The method of Claim 6 wherein the material layer deposited on the
- 30 substrate has a nonuniformity in an optical property that is smaller than a nonuniformity in thickness.

8. The method of Claim 1 further comprising applying radiofrequency power at a second frequency to the target wherein the second frequency is lower than the first frequency.

5 9. The method of Claim 1 further comprising applying radiofrequency power to the substrate.

10 10. The method of Claim 8 further comprising applying radiofrequency power to the substrate.

11. The method of Claim 1 wherein the uniform plasma condition is created without use of a magnet and further comprising applying radiofrequency power to the substrate.

15 12. The method of Claim 1 wherein the target comprises refractory oxides.

13. The method of Claim 12 wherein the target comprises oxides of silicon.

14. The method of Claim 13 wherein the target comprises silicon monoxide.

20

15. The method of Claim 12 wherein the target further comprises compounds of rare earths.

25 16. The method of Claim 8 wherein the refractive index of a first material layer deposited with the radiofrequency power at the second frequency at a first power level is higher than the refractive index of a second material layer deposited with the radiofrequency power at the second frequency at a second power level, wherein the first power level is higher than the second power level and wherein the sum of the power levels of the first frequency and the second frequency are the same during deposition of the first  
30 material layer and the second material layer.

17. The method of Claim 1 wherein the refractive index of a first material layer deposited with the substrate held at a first temperature is higher than the refractive index of

a second material layer deposited with the substrate held at a second temperature wherein the first temperature is higher than the second temperature.

18. The method of Claim 1 wherein the refractive index of a first material layer  
5 deposited at a first radiofrequency power is higher than the refractive index of a second  
material layer deposited at a second radiofrequency power wherein the first power is  
higher than the second power.

19. The method of Claim 1 wherein the gas comprises an inert gas.  
10

20. The method of Claim 1 wherein the gas further comprises a reactive gas  
whereby the refractive index of the material layer is modified compared with the refractive  
index of a material layer formed in the absence of the reactive gas.

21. The method of Claim 20 wherein the reactive gas is a reducing gas and  
15 wherein the refractive index of the material layer is greater than the refractive index of a  
material layer formed in the absence of the reducing gas.

22. The method of Claim 20 wherein the reactive gas is an oxidizing gas and  
20 wherein the refractive index of the material layer is smaller than the refractive index of a  
material layer formed in the absence of the oxidizing gas.

23. The method of Claim 1 wherein the target comprises a plurality of tiles.

24. The method of Claim 23 wherein the tiles comprise an alloy material.  
25

25. A method of making a planar optical device, the method comprising:  
depositing a first layer of cladding material having a first refractive index  
on a substrate by physical vapor deposition to form a first structure, wherein  
radiofrequency power is applied to a planar source of cladding material positioned  
30 opposite the substrate, the source having an area greater than the area of the  
substrate, the power applied in the presence of a gas and under a condition wherein  
a central portion of the source overlying the substrate is exposed to a uniform  
plasma condition; and

depositing a layer of core material on the cladding material to form a second structure, the core material having a second refractive index greater than the first refractive index, the core material deposited by physical vapor deposition, wherein radiofrequency power is applied to a planar source of core material positioned  
5 opposite the first structure, the source of core material having an area greater than the area of the first structure, the power applied in the presence of a gas and under a condition wherein a central portion of the source of core material overlying the first structure is exposed to a uniform plasma condition;

10 26. The method of Claim 25 further comprising:  
depositing a second layer of cladding material on the layer of core material by physical vapor deposition wherein radiofrequency power is applied to the planar source of cladding material positioned opposite the second structure under a condition wherein a central portion of the source overlying the second structure is  
15 exposed to a uniform plasma condition; and  
etching regions of the second layer of the cladding material and a portion of the thickness of the layer of core material to produce a ridge structure in the second layer of cladding material and in a portion of the layer of core material.

20 27. The method of Claim 25 further comprising;  
etching regions of the layer of core material to produce a ridge structure in the layer of core material, forming a third structure; and  
depositing a second layer of cladding material over the ridge structure by  
physical vapor deposition wherein  
25 radiofrequency power is applied to the planar source of cladding material positioned opposite the third structure, under a condition wherein the central portion of the source of cladding material overlying the third structure is exposed to a uniform plasma condition, and  
radiofrequency power is applied to the third structure.

30 28. The method of Claim 27 wherein depositing the first layer of cladding material further comprises applying radiofrequency power to the substrate.

29. The method of Claim 28 wherein depositing the layer of core material further comprises applying radiofrequency power to the second structure.

30. A method of making a planar optical device, the method comprising:  
5 depositing a first layer of cladding material having a first refractive index on a substrate by physical vapor deposition, wherein radiofrequency power is applied to a planar source of cladding material positioned opposite the substrate, the source having an area greater than the area of the substrate, the power applied in the presence of a gas and under a condition wherein a central portion of the  
10 source overlying the substrate is exposed to a uniform plasma condition;  
forming a trench in the first layer of cladding material to form a first structure;  
depositing a layer of core material on the cladding material completely filling the trench, the core material having a second refractive index greater than  
15 the first refractive index, the core material deposited by physical vapor deposition, wherein radiofrequency power is applied to the first structure and radiofrequency power is applied to a planar source of core material positioned opposite the first structure, the source of core material having an area greater than the area of the substrate, the power applied in the presence of a gas and under a condition wherein  
20 a central portion of the source of core material overlying the first structure is exposed to a uniform plasma condition;  
removing core material overlying the first layer of cladding material exposing the cladding material except in the area of the trench to provide a cladding layer with filled trench; and  
25 depositing a layer of cladding material on the cladding layer with filled trench by physical vapor deposition wherein radiofrequency power is applied to the planar source of cladding material positioned opposite the cladding material with filled trench.

30 31. The method of Claim 30 wherein depositing a first layer of cladding material further comprises applying radiofrequency power to the substrate, and wherein depositing a layer of cladding material on the cladding layer with filled trench further comprises applying radiofrequency power to the cladding layer with filled trench.

32. A method of making a composite sputtering target comprising a plurality of tiles, the target used for physical vapor deposition of material, the method comprising:
- sputter coating a side of each of the plurality of tiles with a wetting layer material to within an offset of the edge of each tile;
  - 5 providing a backing plate composed of a metal with thermal expansion coefficient similar to the thermal expansion coefficient of the plurality of tiles;
  - plasma spray coating the backing plate with a ceramic material so as to cover the regions of the backing plate exposed during physical vapor deposition;
  - sputter coating regions of the backing plate corresponding in placement to
  - 10 the wetted regions of the tiles with a wetting layer;
  - wetting the sputtered regions of the plurality of tiles and of the backing plate with solder material; and
  - assembling the plurality of tiles on the backing plate so as to form a solder bonded non contacting array of uniformly spaced tiles.
- 15
33. The method of Claim 32 wherein the plurality of tiles comprise an alloy material.
34. The method of Claim 32 wherein the wetting layer material comprises
- 20 chrome or nickel or mixtures thereof.
35. The method of Claim 32 wherein the ceramic material comprises alumina or silica.
- 25 36. The method of Claim 32 wherein the solder material is indium.

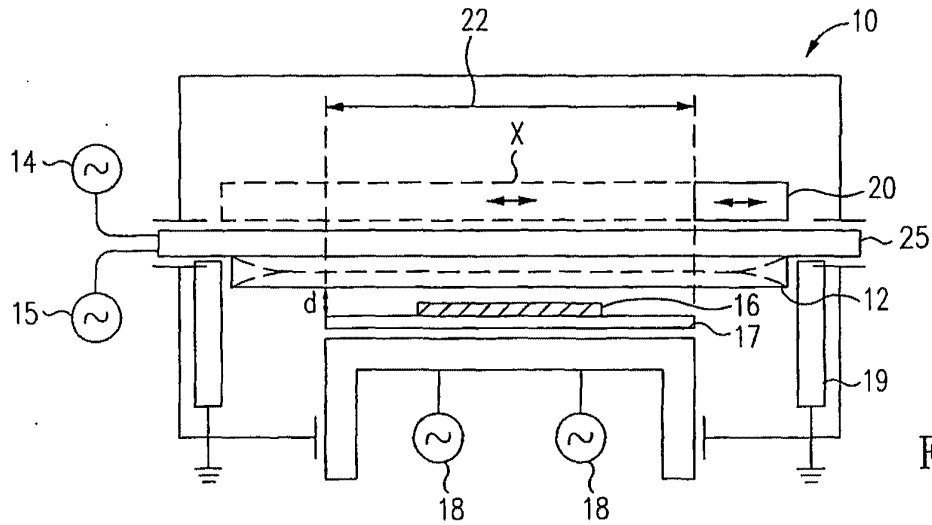


FIG. 1a

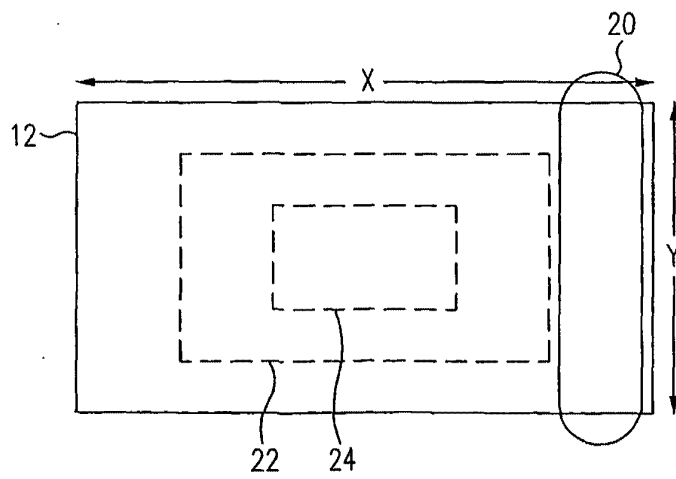


FIG. 2



2/5

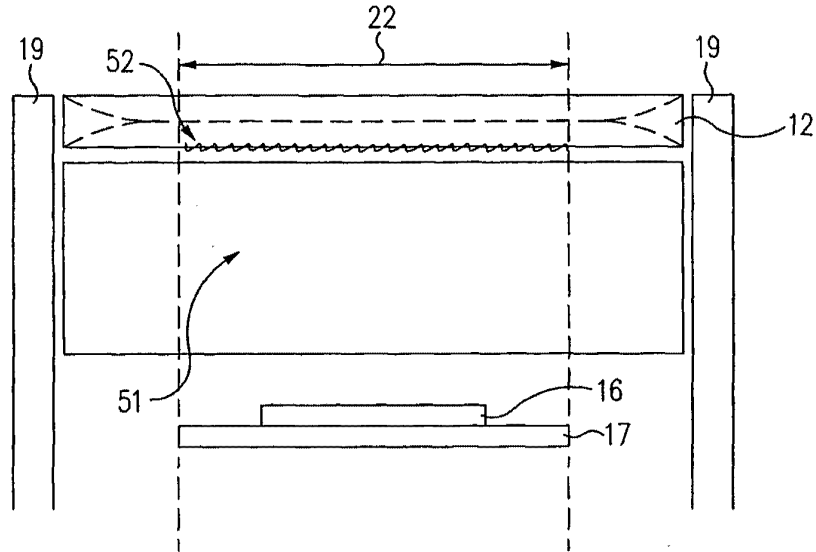


FIG. 1b

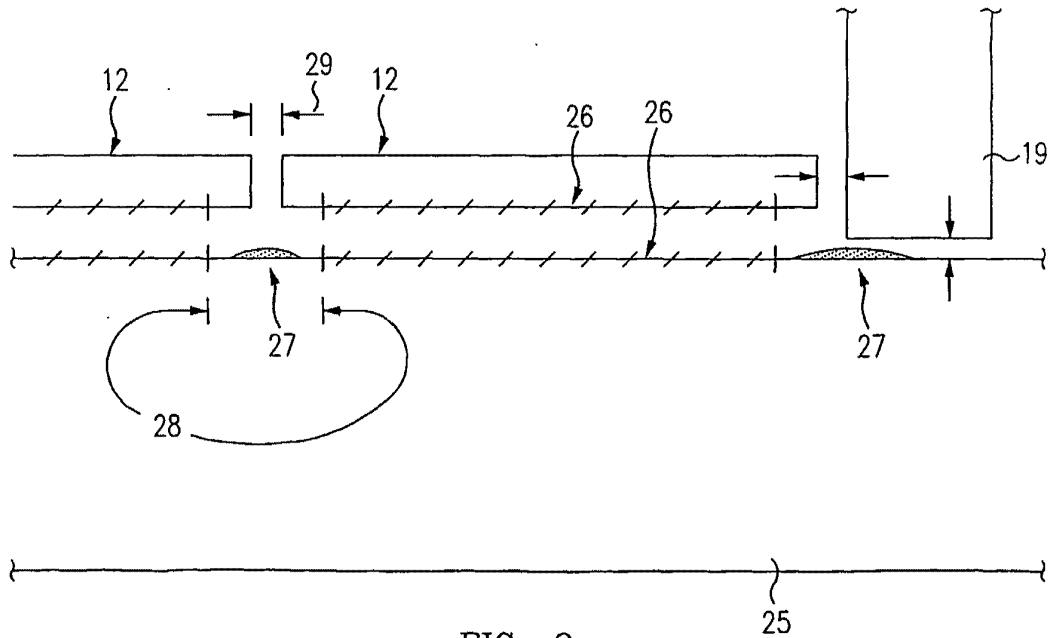


FIG. 3

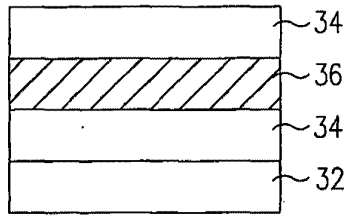


FIG. 4a

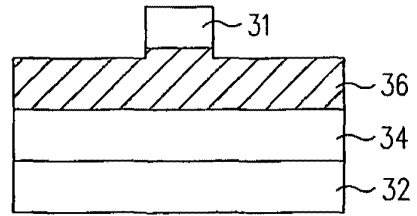


FIG. 4b

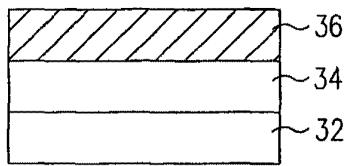


FIG. 5a

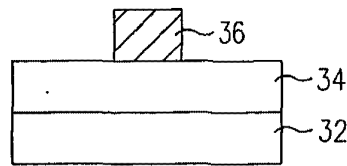


FIG. 5b

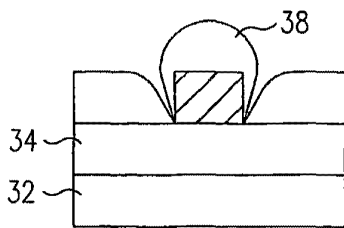


FIG. 5c

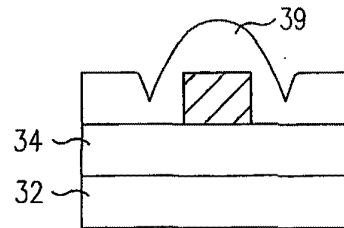


FIG. 5d

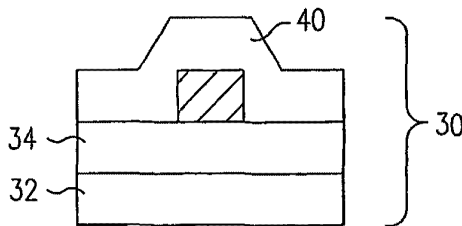


FIG. 5e

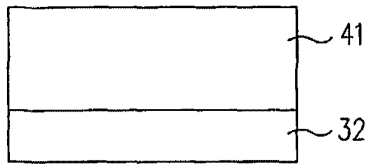


FIG. 6a

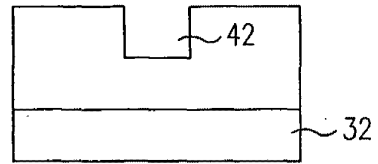


FIG. 6b

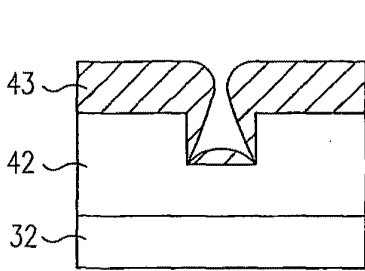


FIG. 6c

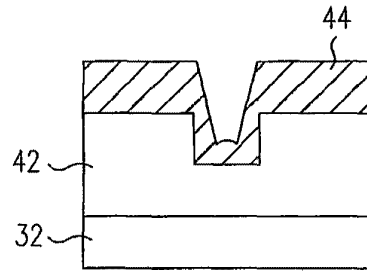


FIG. 6d

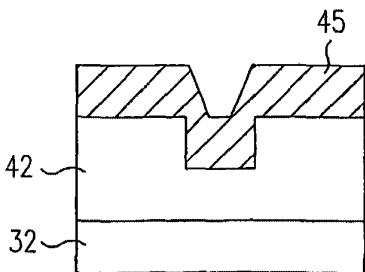


FIG. 6e

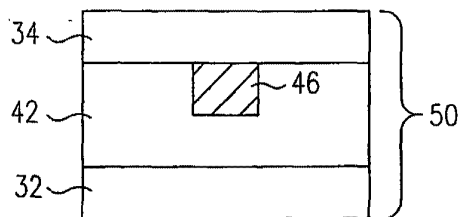


FIG. 6f

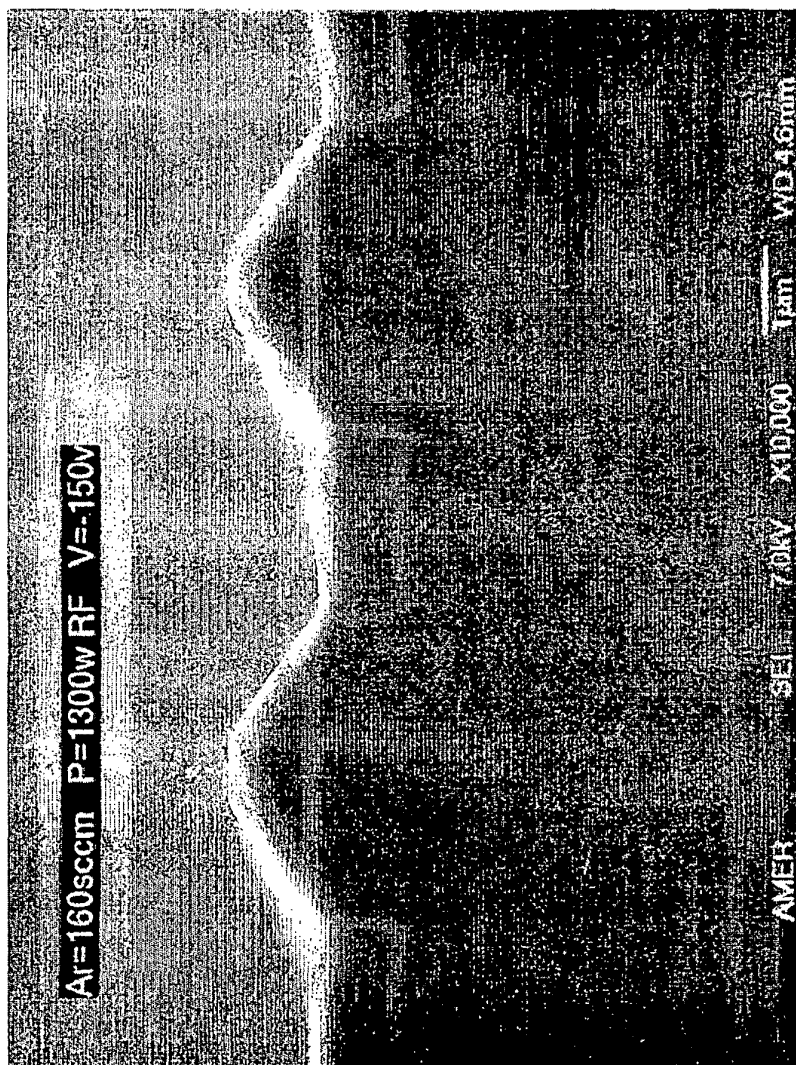


FIG. 7

(12) INTERNATIONAL APPLICATION PUBLISHED UNDER THE PATENT COOPERATION TREATY (PCT)

(19) World Intellectual Property Organization  
International Bureau



(43) International Publication Date  
14 February 2002 (14.02.2002)

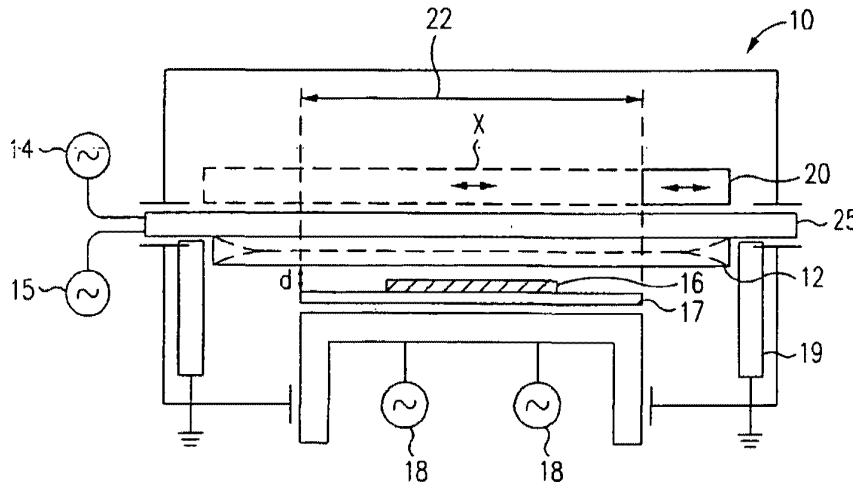
PCT

(10) International Publication Number  
WO 02/012932 A3

- (51) International Patent Classification<sup>7</sup>: C23C 14/34, 14/35  
Court, Morgan Hill, CA 95037 (US). ZHANG, Hongmei; 1330 Rodney Drive, San Jose, CA 95118 (US). PETHE, Rajiv; 3680 Springbrook Avenue, San Jose, CA 95148 (US).
- (21) International Application Number: PCT/US01/22750
- (22) International Filing Date: 18 July 2001 (18.07.2001)
- (25) Filing Language: English
- (26) Publication Language: English
- (30) Priority Data:  
09/633,307 7 August 2000 (07.08.2000) US  
09/903,050 10 July 2001 (10.07.2001) US
- (71) Applicant: SYMMORPHIX, INC. [US/US]; 1278 Reamwood Avenue, Sunnyvale, CA 94089-2233 (US).
- (72) Inventors: DEMARAY, Richard, E.; 190 Fawn Lane, Portola Valley, CA 94028 (US). WANG, Kai-An; 1082 West Hill Court, Cupertino, CA 95014 (US). MULLA-PUDI, Ravi, B.; 2117 Shiangzone Court, San Jose, CA 95121 (US). STADTLER, Douglas, P.; 18509 Murphy
- (74) Agents: SAXON, Roberta, P. et al.; Skjerven Morrill MacPherson LLP, 25 Metro Drive, Suite 700, San Jose, CA 95110 (US).
- (81) Designated States (national): AE, AG, AL, AM, AT, AU, AZ, BA, BB, BG, BR, BY, BZ, CA, CH, CN, CO, CR, CU, CZ, DE, DK, DM, DZ, EC, EE, ES, FI, GB, GD, GE, GH, GM, HR, HU, ID, IL, IN, IS, JP, KE, KG, KP, KR, KZ, LC, LK, LR, LS, LT, LU, LV, MA, MD, MG, MK, MN, MW, MX, MZ, NO, NZ, PL, PT, RO, RU, SD, SE, SG, SI, SK, SL, TJ, TM, TR, TT, TZ, UA, UG, UZ, VN, YU, ZA, ZW.
- (84) Designated States (regional): ARIPO patent (GH, GM, KE, LS, MW, MZ, SD, SL, SZ, TZ, UG, ZW), Eurasian patent (AM, AZ, BY, KG, KZ, MD, RU, TJ, TM), European patent (AT, BE, CH, CY, DE, DK, ES, FI, FR, GB, GR, IE, IT, LU, MC, NL, PT, SE, TR), OAPI patent (BF, BJ, CF, CG, CI, CM, GA, GN, GW, ML, MR, NE, SN, TD, TG).

[Continued on next page]

(54) Title: METHODS FOR MANUFACTURING PLANAR OPTICAL DEVICES



(57) Abstract: Physical vapor deposition processes provide optical materials with controlled and uniform refractive index that meet the requirements for active and passive planar optical devices. All processes use radio frequency (RF) (14) sputtering with a wide area target (12), larger in area than the substrate (16) on which material is deposited, and uniform plasma conditions which provide uniform target erosion. In addition, a second RF (15) frequency can be applied to the sputtering target and RF power (18) can be applied to the substrate (16) producing substrate bias. Multiple approaches for controlling refractive index are provided. The present RF sputtering methods for material deposition and refractive index control are combined with processes commonly used in semiconductor fabrication to produce planar optical devices such surface ridge devices, buried ridge devices and buried trench devices. A method for forming composite wide area targets from multiple tiles is also provided.



WO 02/012932 A3



**Published:**

- with international search report
- before the expiration of the time limit for amending the claims and to be republished in the event of receipt of amendments

*For two-letter codes and other abbreviations, refer to the "Guidance Notes on Codes and Abbreviations" appearing at the beginning of each regular issue of the PCT Gazette.*

**(88) Date of publication of the international search report:**

3 October 2002

INTERNATIONAL SEARCH REPORT

International Application No  
PCT/US 01/22750

<b>A. CLASSIFICATION OF SUBJECT MATTER</b> IPC 7 C23C14/34 C23C14/35		
According to International Patent Classification (IPC) or to both national classification and IPC		
<b>B. FIELDS SEARCHED</b>		
Minimum documentation searched (classification system followed by classification symbols) IPC 7 C23C		
Documentation searched other than minimum documentation to the extent that such documents are included in the fields searched		
Electronic data base consulted during the international search (name of data base and, where practical, search terms used) PAJ, WPI Data, IBM-TDB, EPO-Internal		
<b>C. DOCUMENTS CONSIDERED TO BE RELEVANT</b>		
Category *	Citation of document, with indication, where appropriate, of the relevant passages	Relevant to claim No.
X	WO 97 35044 A (MATERIALS RESEARCH CORP) 25 September 1997 (1997-09-25)	1
Y	page 1, line 28 -page 3, line 7; figure 1	2-7, 12-15,19
Y	--- EP 0 510 883 A (AMERICAN TELEPHONE & TELEGRAPH) 28 October 1992 (1992-10-28) cited in the application column 7, line 45 -column 9, line 11	12-15,19
Y	--- PATENT ABSTRACTS OF JAPAN vol. 018, no. 215 (C-1191), 18 April 1994 (1994-04-18) & JP 06 010127 A (ULVAC JAPAN LTD), 18 January 1994 (1994-01-18) abstract --- -/--	2-4
<input checked="" type="checkbox"/> Further documents are listed in the continuation of box C.		
<input checked="" type="checkbox"/> Patent family members are listed in annex.		
* Special categories of cited documents :		
"A" document defining the general state of the art which is not considered to be of particular relevance		"T" later document published after the international filing date or priority date and not in conflict with the application but cited to understand the principle or theory underlying the invention
"E" earlier document but published on or after the international filing date		"X" document of particular relevance; the claimed invention cannot be considered novel or cannot be considered to involve an inventive step when the document is taken alone
"L" document which may throw doubts on priority claim(s) or which is cited to establish the publication date of another citation or other special reason (as specified)		"Y" document of particular relevance; the claimed invention cannot be considered to involve an inventive step when the document is combined with one or more other such documents, such combination being obvious to a person skilled in the art.
"O" document referring to an oral disclosure, use, exhibition or other means		"&" document member of the same patent family
"P" document published prior to the international filing date but later than the priority date claimed		
Date of the actual completion of the international search  25 February 2002		Date of mailing of the international search report  19. 07. 2002
Name and mailing address of the ISA European Patent Office, P.B. 5818 Patentlaan 2 NL - 2280 HV Rijswijk Tel. (+31-70) 340-2040, Tx. 31 651 epo nl, Fax: (+31-70) 340-3016		Authorized officer  EKHULT, H

INTERNATIONAL SEARCH REPORT

International Application No  
PCT/US 01/22750

C.(Continuation) DOCUMENTS CONSIDERED TO BE RELEVANT		
Category *	Citation of document, with indication, where appropriate, of the relevant passages	Relevant to claim No.
Y	US 4 437 966 A (HOPE LAWRENCE L ET AL) 20 March 1984 (1984-03-20) column 2, line 50 -column 4, line 54; figures 2-4	5-7
A	--- EP 0 820 088 A (APPLIED KOMATSU TECHNOLOGY INC) 21 January 1998 (1998-01-21) cited in the application column 1, line 1 -column 4, line 13; figures 1-6 column 6, line 10 - line 19 -----	6,7

Form PCT/ISA/210 (continuation of second sheet) (July 1992)



INTERNATIONAL SEARCH REPORT

International application No.  
PCT/US 01/22750

**Box I Observations where certain claims were found unsearchable (Continuation of item 1 of first sheet)**

This International Search Report has not been established in respect of certain claims under Article 17(2)(a) for the following reasons:

1.  Claims Nos.:  
because they relate to subject matter not required to be searched by this Authority, namely:
  
2.  Claims Nos.:  
because they relate to parts of the International Application that do not comply with the prescribed requirements to such an extent that no meaningful International Search can be carried out, specifically:
  
3.  Claims Nos.:  
because they are dependent claims and are not drafted in accordance with the second and third sentences of Rule 6.4(a).

**Box II Observations where unity of invention is lacking (Continuation of item 2 of first sheet)**

This International Searching Authority found multiple inventions in this international application, as follows:

see additional sheet

1.  As all required additional search fees were timely paid by the applicant, this International Search Report covers all searchable claims.
  
2.  As all searchable claims could be searched without effort justifying an additional fee, this Authority did not invite payment of any additional fee.
  
3.  As only some of the required additional search fees were timely paid by the applicant, this International Search Report covers only those claims for which fees were paid, specifically claims Nos.:
  
4.  No required additional search fees were timely paid by the applicant. Consequently, this International Search Report is restricted to the invention first mentioned in the claims; it is covered by claims Nos.:

1-7, 12-15, 19

**Remark on Protest**

- The additional search fees were accompanied by the applicant's protest.
- No protest accompanied the payment of additional search fees.

FURTHER INFORMATION CONTINUED FROM PCT/ISA/ 210

This International Searching Authority found multiple (groups of) inventions in this international application, as follows:

1. Claims: 1-7,12-15,19

Sputtering method using a time averaged uniform magnetic field.

2. Claims: 1,8,10,16

Sputtering method using dual frequency.

3. Claims: 1,9,11

Sputtering method using RF substrate bias.

4. Claims: 1,17,18,20-22

Sputtering method using sputtering parameters to influence the refractive index of the coating.

5. Claims: 25-31

Methods for making optical devices.

6. Claims: 1,23,24,32-36

Method for making a composite target.

**INTERNATIONAL SEARCH REPORT**

Information on patent family members

International Application No  
PCT/US 01/22750

Patent document cited in search report	Publication date	Patent family member(s)	Publication date	
WO 9735044	A	25-09-1997	AU 1978497 A WO 9735044 A1	10-10-1997 25-09-1997
EP 0510883	A	28-10-1992	US 5119460 A DE 69212207 D1 DE 69212207 T2 EP 0510883 A2 JP 2501395 B2 JP 5160498 A US 5200029 A	02-06-1992 22-08-1996 06-02-1997 28-10-1992 29-05-1996 25-06-1993 06-04-1993
JP 06010127	A	18-01-1994	NONE	
US 4437966	A	20-03-1984	CA 1206914 A1 DE 3378710 D1 EP 0105407 A2 JP 4002667 B JP 59116379 A	01-07-1986 19-01-1989 18-04-1984 20-01-1992 05-07-1984
EP 0820088	A	21-01-1998	US 5855744 A EP 0820088 A2 JP 10096078 A TW 425590 B	05-01-1999 21-01-1998 14-04-1998 11-03-2001

This Page Is Inserted by IFW Operations  
and is not a part of the Official Record

## **BEST AVAILABLE IMAGES**

Defective images within this document are accurate representations of the original documents submitted by the applicant.

Defects in the images may include (but are not limited to):

- BLACK BORDERS
- TEXT CUT OFF AT TOP, BOTTOM OR SIDES
- FADED TEXT
- ILLEGIBLE TEXT
- SKEWED/SLANTED IMAGES
- COLORED PHOTOS
- BLACK OR VERY BLACK AND WHITE DARK PHOTOS
- GRAY SCALE DOCUMENTS

**IMAGES ARE BEST AVAILABLE COPY.**

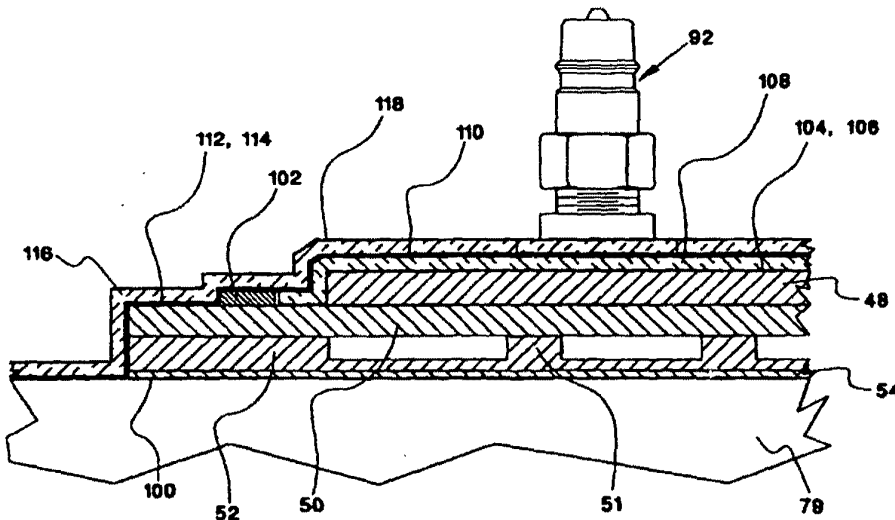
**As rescanning documents *will not* correct images,  
please do not report the images to the  
Image Problem Mailbox.**



INTERNATIONAL APPLICATION PUBLISHED UNDER THE PATENT COOPERATION TREATY (PCT)

<p>(51) International Patent Classification<sup>6</sup> : <b>C23C 14/34, H01J 37/34</b></p>	<p>A1</p>	<p>(11) International Publication Number: <b>WO 96/23085</b> (43) International Publication Date: 1 August 1996 (01.08.96)</p>
<p>(21) International Application Number: PCT/US95/01089 (22) International Filing Date: 25 January 1995 (25.01.95) (71) Applicant (for all designated States except US): APPLIED KOMATSU TECHNOLOGY, INC. [JP/JP]; c/o Applied Komatsu Technology America, Inc., 3050 Bowers Avenue, M/S 02634, Santa Clara, CA 95054 (US). (72) Inventors; and (75) Inventors/Applicants (for US only): DEMARAY, Richard, Ernest [US/US]; 190 Fawn Lane, Portola Valley, CA 94028 (US). HERRERA, Mamel [US/US]; 1583 Brandywine Road, San Mateo, CA 94402 (US). (74) Agent: STERN, Robert, J.; Legal/Patent Dept., Applied Materials, Inc., 3050 Bower Avenue, M/S 2634, Santa Clara, CA 95054 (US).</p>	<p>(81) Designated States: AM, AT, AU, BB, BG, BR, BY, CA, CH, CN, CZ, DE, DK, ES, FI, GB, GE, HU, JP, KE, KG, KP, KR, KZ, LK, LT, LU, LV, MD, MG, MN, MW, MX, NL, NO, NZ, PL, PT, RO, RU, SD, SE, SI, SK, TJ, TT, UA, US, UZ, VN, European patent (AT, BE, CH, DE, DK, ES, FR, GB, GR, IE, IT, LU, MC, NL, PT, SE). OAPI patent (BF, BJ, CF, CG, CI, CM, GA, GN, ML, MR, NE, SN, TD, TG).  Published With international search report. With amended claims and statement.</p>	

(54) Title: AUTOCLAVE BONDING OF SPUTTERING TARGET ASSEMBLY



(57) Abstract

Fabrication techniques for an integrated sputtering target assembly include pressure assisted bonding of soldered layers of material, in particular, soldering of the target material to its backing plate; pressure assisted curing of structural adhesives used to join a finned cover plate (52) to a backing plate (50) which between them form passages for fluid cooling; and bonding an electrical insulating layer to the back surface of the backing plate. The pressure to assist in bonding is typically applied by an autoclave. The cooling fluid passages disposed between a cover and a finned backing plate can be sealed by using laser welding or electron beam welding rather than closing the cooling passages with structural adhesives.

**FOR THE PURPOSES OF INFORMATION ONLY**

Codes used to identify States party to the PCT on the front pages of pamphlets publishing international applications under the PCT.

AM	Armenia	GB	United Kingdom	MW	Malawi
AT	Austria	GE	Georgia	MX	Mexico
AU	Australia	GN	Guinea	NE	Niger
BB	Barbados	GR	Greece	NL	Netherlands
BE	Belgium	HU	Hungary	NO	Norway
BF	Burkina Faso	IE	Ireland	NZ	New Zealand
BG	Bulgaria	IT	Italy	PL	Poland
BJ	Benin	JP	Japan	PT	Portugal
BR	Brazil	KE	Kenya	RO	Romania
BY	Belarus	KG	Kyrgyzstan	RU	Russian Federation
CA	Canada	KP	Democratic People's Republic of Korea	SD	Sudan
CF	Central African Republic	KR	Republic of Korea	SE	Sweden
CG	Congo	KZ	Kazakhstan	SG	Singapore
CH	Switzerland	LI	Liechtenstein	SI	Slovenia
CI	Côte d'Ivoire	LK	Sri Lanka	SK	Slovakia
CM	Cameroon	LR	Liberia	SN	Senegal
CN	China	LT	Lithuania	SZ	Swaziland
CS	Czechoslovakia	LU	Luxembourg	TD	Chad
CZ	Czech Republic	LV	Latvia	TG	Togo
DE	Germany	MC	Monaco	TJ	Tajikistan
DK	Denmark	MD	Republic of Moldova	TT	Trinidad and Tobago
EE	Estonia	MG	Madagascar	UA	Ukraine
ES	Spain	ML	Mali	UG	Uganda
FI	Finland	MN	Mongolia	US	United States of America
FR	France	MR	Mauritania	UZ	Uzbekistan
GA	Gabon			VN	Viet Nam

**AUTOCLAVE BONDING OF SPUTTERING  
TARGET ASSEMBLY**

5

**Field of the Invention**

This invention relates to techniques used to fabricate internally cooled sputtering target assemblies generally used in planar magnetron sputtering, and in particular to fabrication techniques used to enhance and assure parallelism between the surface of a target material and the substrate being sputter deposited.

**Background of the Invention**

Sputtering describes a number of physical techniques commonly used in, for example, the semiconductor industry for the deposition of thin films of various metals such as aluminum, aluminum alloys, refractory metal silicides, gold, copper, titanium-tungsten, tungsten, molybdenum, tantalum, indium-tin-oxide (ITO) and less commonly silicon dioxide and silicon on an item (a substrate), for example a wafer or glass plate being processed. In general, the techniques involve producing a gas plasma of ionized inert gas "particles" (atoms or molecules) by using an electrical field in an evacuated chamber. The ionized particles are then directed toward a "target" and collide with it. As a result of the collisions, free atoms are released from the surface of the target as atom sized projectiles, essentially converting the target material to its gas phase. Most of the free atoms which escape the target surface condense (the atomic sized projectiles lodge on the surface of the substrate at impact) and form (deposit) a thin film on the surface of the object (e.g. wafer, substrate) being processed, which is located a relatively

1

**SUBSTITUTE SHEET (RULE 26)**

short distance from the target.

One common sputtering technique is magnetron sputtering. When processing wafers using magnetron sputtering, a magnetic field is used to concentrate sputtering action in the region of the magnetic field so that sputtering  
5 occurs at a higher rate and at a lower process pressure. The target itself is electrically biased with respect to the wafer and chamber, and functions as a cathode. The magnetic field's influence on the ions is proportional to its distance from the front of the target. Optimally a target assembly (the target and its backing plate) is thin to allow the magnetic field to have the greatest influence.

10 In generating the gas plasma and creating ion streams impacting on the cathode, considerable energy is used. This energy must be dissipated to avoid melting or nearly melting the structures and components involved. A technique used for cooling sputtering target assemblies is to pass water or other cooling liquid through fixed internal passages of the sputtering target assembly.

15 An example is shown in the simplified perspective sketch of Figure 1, a sputtering system designed for large rectangular substrates, which includes a relatively thin sputtering target assembly with internal cooling passages. (Details of the chamber and its operation are described in earlier U.S. Patent Applications of the inventors: U.S. Serial No. 08/157,763 filed 11-24-93 and U.S. Serial No.  
20 08/236,715 filed 4-29-94, now hereby incorporated by reference herein.) The processing/sputtering chamber 30 encloses a dark space ring 31 surrounding a substrate 32 to be sputter deposited. The upper flange of the sputtering chamber 30 supports a lower insulating ring 33 supporting a sputtering target assembly 40. The target material on the sputtering target assembly is facing toward the substrate  
25 32 to be sputtered. The target assembly is negatively biased relative to the substrate to effect the sputtering. Inlet cooling lines 36 and outlet cooling lines 37 connect to cooling passages in the sputtering target assembly 40 to cool the assembly during sputtering. The top of the sputtering target assembly 40 is enclosed by a top chamber 35 supported on the back of the sputtering target  
30 assembly by an upper insulating ring 34. As fully discussed in the references



previously cited, the top chamber 35 can house a moveable magnetron in an evacuated top chamber. The top chamber can be evacuated so that its pressure approaches the pressure of the process chamber. The force exerted on the area of the target assembly due to differential pressure between the process chamber and the top chamber is then minimal and easily restrained by the thin sputtering target assembly 40.

A multi-layered sputtering target assembly 40, as shown in Figures 2 and 3, is typically assembled according to the above mentioned patent applications using a two step process. In one step, a target material 48 is solder bonded to the backing plate 50. In another step, a finned (or grooved) cover plate 52 is bonded to the back of the backing plate 50 using a structural epoxy based adhesive. The structural epoxy based adhesive is cured by putting it in position and raising the temperature of the pieces to be joined while at the same time applying a pressure to keep the parts in intimate contact throughout the heating cycle. The order in which the two steps are done is dependent on the melting temperature of the solder and the curing temperature of the structural epoxy. The higher temperature bonding process is done first so that the integrity of the first formed bond is not affected by the subsequent process.

The process and materials used in producing a structural epoxy bond generally create a good bond; however, the cooling fluid occasionally leaks due to imperfections in bonding thereby causing such sputtering target assemblies to be rejected. The factors affecting the structural epoxy bond integrity are 1) surface treatment of the pieces to be joined, 2) epoxy selection and curing procedure, and 3) mechanical fitting or mating of the surfaces being joined prior to adhesive cure.

Surface treatment removes mechanically weak or non-adherent surface film on the metal. For example, surface treatment may simply consist of mechanically abrading the surface to be bonded in order to obtain a "clean" metal surface. Or, for superior results, the procedure may involve a) degreasing, followed by b) an acid etch to remove any visible oxide film or scale, c) rinsing to remove all traces of the acid, d) a surface-conditioning step to deliberately form a corrosion film of

controlled chemical composition and thickness which promotes primer adhesion, e) drying, and f) priming within an hour to seal the surface from atmospheric oxygen and moisture.

Epoxy selection is based on several factors including: type of carrier,  
5 strength of the adhesive, adhesion to the primed surface, curing temperature and pressure procedure, and ability of the adhesive to flow to create a leak-free joint.

Surface treatment, epoxy selection, and curing procedures are factors controlled by manufacturing rigor. However, good mechanical fitting or mating of the surfaces being joined is also required to achieve leak-free joints. Distortion  
10 and voids are introduced by the two-step soldering process presently used to join large areas (e.g. 643mm x 550mm target material dimension) of a) dissimilar metals and/or b) non-uniformly heated or cooled similar metals. The present process includes the solder wetting of the two surfaces to be bonded. The target material is then heated and a pool of solder is created at the soldering location.  
15 The backing plate, also heated, is then slid into the pool of solder to avoid trapping the solder oxide that normally floats over the molten solder, and the weight of the piece and a light pressure cause the solder in the pool to spread out over the surfaces to be soldered and bring the two materials generally in close contact. The pieces are held aligned one to the other until the solder cools below  
20 its melting temperature and the two pieces are bonded.

For example, when solder bonding indium-tin-oxide (ITO) to a commercially pure titanium backing plate, during cooling from the soldering temperature (e.g., 156°C for pure indium solder) to ambient temperature, the differential thermal contraction of the soldered connection tends to cause bending  
25 of the pieces. The edges of the target material, being the first to cool, initially form a stronger bond than the higher temperature center of the target. As a result, the strong connection between pieces of the outer edge of the target material causes the center of the target material to buckle and lift from the backing plate at the center of the target, by as much as 0.125" (3.175 mm), as the target material  
30 and backing plate continue to contract at different rates. In the subsequent

structural epoxy bond step (the finned cover 52 is bonded to this highly distorted target/backing plate assembly), mechanical fitting or mating of the surfaces being joined is difficult. Poor mating results in uneven bond thickness which can cause the cooling fluid to leak resulting in rejection of the sputtering target assembly.

5           In addition, if such a sputtering target assembly is not flattened, the non-parallelism between the target material and the substrate being sputtered creates non-uniform films on the substrate. Raised areas at the center of the target material may create a void behind the raised area, or the target material may fracture. Such voids change the thermal conductivity between the target and  
10 backing plate and the temperature distribution across its face. Since the distribution of sputtered material and the rate of sputtering of the target are directly dependent respectively on the target material distance from the substrate and on its temperature, variations in the gap (distance) between the target and substrate and in the temperature of the target material will also change the  
15 uniformity of target material sputter deposited on the substrate.

          Since the object of large area sputtering chambers, as described above, includes uniform film thickness across the entire area of the substrate being sputter deposited, variations in film thickness due to variable properties in the target surface of the sputtering target assembly are a great impediment to improving  
20 processing efficiency and sputter depositing a uniform film thickness over the whole surface.

#### Summary of the Invention

          A method according to the present invention includes overcoming the  
25 distortion and imperfections introduced by the sputtering target assembly fabrication techniques described above to provide generally uniform target properties across the surface of the target. Specifically, the improved fabrication techniques include: pressure-assisted bonding when using solder and/or structural adhesives to bond the material layers making up a sputtering target assembly; and  
30 enclosing cooling passages in the target backing plate by laser welding or electron

beam welding one or more cover plates over the void in the backing plate forming the cooling passages. Variations of both techniques are discussed.

5 These techniques according to the invention, reduce the number of steps in the fabrication process and reduce, if not eliminate, distortion due to differences in coefficients of thermal expansion of adjacent layers. They also virtually eliminate the possibility of cooling fluid leakage due to the failure of cured adhesive based structural bonds.

10 In one method (or technique), the sputtering target assembly (comprised principally of backing plate, finned cover (plate), insulating sheet, and target material layers) is, as required, machined, ground, lapped, chem-cleaned, primed, and polished prior to assembly. The final step of bonding the layers together under pressure is performed inside a gas-tight fabric bag (preferably in an oxygen-depleted environment) inside an autoclave. The pressurized autoclave exerts a uniform force on the surface of the bag to keep the layers in tight contact throughout the thermal cycling of bond formation and/or curing. During the cooling cycle, the exerted pressure forces the solder layer to plastically flow or yield preventing the assembly from distorting. Spacers, disposed between the target material and backing plate and interspersed in the solder layer control the thickness, uniformity, and integrity of the joint created by the solder layer.

20 In the bonding step, pressure (preferably provided in an autoclave) bonding the target to the backing plate using solder, and bonding the finned (grooved) cover plate to the backing plate using a structural adhesive are performed in one step. The electrical insulating layer can be bonded to the back surface of the target assembly using a structural adhesive during this same step. To perform this bonding step, the target assembly is partially double vacuum bagged to isolate the solder bonding process from the structural bonding process. One (the lower) vacuum bag configuration (system) is attached to the backing plate and encloses only the target material to be solder bonded to the backing plate. The second (the upper) vacuum bag configuration (system) generally encloses the lower bag system, the backing plate, the finned cover, and the electrical insulating sheet and

30

provides a pass through gas connection to the lower vacuum bag. An epoxy based structural adhesive laminate placed between the backing plate and finned cover plate and between the finned cover plate and the electrical insulation sheet bonds these layers together.

- 5           The vacuum bags are first evacuated and the autoclave pressure is increased to approximately 15 psi above atmospheric. The vacuum bags are then backfilled with a moisture-free inert or oxygen absorbing gas to approximately one atmosphere to eliminate the possibility (in the event of bag failure) that a vacuum system evacuating the bag will suddenly receive high pressure gas from the  
10 autoclave environment. The autoclave pressure is then increased to provide the desired pressure on the unbonded target assembly layers. The assembly is then heated and cooled according to a predefined procedure.

- A variation of this method is to solder bond the target to the backing plate first, then enclose the whole assembly in a vacuum bag system and cure the  
15 structural adhesive bonded pieces in an autoclave while, at the same time, stress relieving and flattening the target backing plate sub-assembly.

          In another variation of this method, the target is solder bonded in the autoclave first, then the cover to hold the cooling fluid is attached by means of fasteners sealed by gasket type (preferably O-ring) seals.

- 20           A second method according to the invention, involves construction and closure of the void forming the cooling fluid passages in the backing plate and cover assembly. The backing plate includes a recess to receive the cover configured to fit in the recess. The cover and backing plate are joined by laser welding around the edge between the recess and the cover and by spot or seam  
25 welding across the field of the cover at generally regularly spaced locations corresponding to the ends of fins (or walls between grooves) in the finned backing plate. A variation would be to use electron beam welding (a low input of heat to avoid material distortion due to welding is desired). The target material can then be solder bonded to the welded assembly by a) solder bonding the target to the  
30 welded backing plate using a single vacuum-bagged autoclave procedure, or b)

solder bonding the target to the welded backing plate first, then enclosing the whole assembly in a vacuum bag to stress relieve and flatten the target assembly in the autoclave.

5 **Brief Description of the Drawings**

Figure 1 is a perspective view of a simplified sputtering chamber system using a sputtering target assembly 40 fabricated according to the invention;

Figure 2 is a plan view of a target side of a sputtering target assembly according to the invention;

10 Figure 3 is a side cross-section view of Figure 2 taken at 3-3;

Figure 4 is a side cross-sectional exploded view showing one embodiment of the layers of material involved in assembling a target assembly such as the one shown in Figure 3;

15 Figure 5 is a side cross-sectional exploded view showing a second embodiment of layers of material used in assembling a target assembly such as the one shown in Figure 3;

Figure 6 shows a close-up view of the assembled target assembly as pictured in Figure 3;

20 Figure 7 shows a panel of target material consisting of three tiles used with the sputtering target assembly according to the invention;

Figure 8 shows a tape a) wrapped around the tiles to cover the joints between the tiles of the target panel, and b) covering the target side of the tiles of Figure 7;

25 Figures 8A and 8B show a pre-assembly perspective view and a final configuration cross sectional view of a joint between adjacent tiles as shown in Figs. 8, 9 and 10;

Figure 9 shows the assembly of the target panel of Figure 8 on a base plate according to the invention;

30 Figure 10 shows a perspective view of the assembled sputtering target assembly of Figure 9;

Figure 11 shows a partial cutaway view of a bottom of a target backing plate utilizing two welded cover panels covering the cooling passage void in the backing plate;

Figure 12 shows a cross-section of Figure 11 taken at 12-12;

5 Figure 13 shows a target backing plate having the cooling passage void covered by a single cover plate;

Figure 14 shows a close-up cross-sectional view of typical welds at the edge of the cover plate and along the tops of the fins for finned backing plate assemblies with welded cover plates as shown in Figures 11, 12, 13, and 15;

10 Figure 15 shows another embodiment of a target backing plate with two separate cover plates;

Figure 16 shows an overall side cross-sectional view of the material layers used to envelope and create bags around the target assembly being processed in an autoclave;

15 Figure 17 shows a simplified perspective view of the layers of Figure 16, but not showing gas connection fittings;

Figure 18 shows a plan view of the polyamide tape layer on the backing plate surrounding the target material used when processing the target assembly according to the invention;

20 Figure 19 shows a side cross-sectional view of the items of Figure 16 in position for processing;

Figure 20 shows a close-up view of the material layers of Figure 19 surrounding the gas fitting 92;

25 Figure 21 shows a close-up view of the edge seal of the outside bag shown in close proximity to the gas fitting 90;

Figure 22 shows a configuration for providing thermocouple wiring into the vacuum bag enclosures to monitor the temperature of the target material and/or backing plate;

30 Figure 23 is a side view of a typical gas fitting connection through a barrier film of a vacuum bag;

Figure 24 is a side cross-sectional exploded view of a single vacuum bag bonding system according to the invention;

Figure 25 is a side cross-sectional view of the material layers of Figure 24 ready to be bonded according to the invention;

5 Figure 26 is a plan view of the sputtering target assembly as pictured in Figure 9; it clearly shows one example of the possible locations for gas connections to the gas barrier layers of the vacuum bags; and

Figure 27 is a perspective view showing a typical configuration of a gas connection through the outer (upper) bag barrier to the inner (lower) bag barrier of the dual bag configuration as pictured in Figures 16, 19, 20, and 26.

#### Detailed Description

Figure 1, as discussed above, shows a sputtering process system which uses a sputtering target assembly 40 fabricated according to the invention.

15 A general configuration of an embodiment according to the invention is shown in Figure 2. The integrated sputtering target assembly 40 is shown in plan view with its target side up. The sputtering target material 48 is bonded to the backing plate 50. Bonds can be made by soldering, diffusion bonding, or other techniques which provide and maintain satisfactory bonds between dissimilar  
20 metals at process temperatures. In other instances (e.g., aluminum or titanium) the target 48 and backing plate 50 may be a monolith of a single material requiring no bonding. In general, it is preferable to machine, grind, lap and polish the target side of the backing plate to form a highly polished vacuum sealing surface 77 (preferably polished to a surface finish of  $8\mu\text{in}$  ( $0.20\mu\text{m}$ ) Ra, a  
25 mirror finish), on the backing plate border 78, circumscribing the target area prior to bonding the target material 48. This surface 77 provides an exceptional leak-tight seal when an O-ring is placed against it. The backing plate 50 includes inlet water fitting ports 67 and 68, outlet water fitting ports 69 and 71, and a rough vacuum port 75 which are preferably machined into the backing plate 50  
30 prior to bonding according to the invention.



Figure 3 is a cross-sectional view of Figure 2 taken at 3-3 showing target material 48 attached to backing plate 50 which, in turn, is attached to a finned cover plate 52 which is covered on its outside surface by an electrical insulating sheet 54.

5 Figure 4 is an exploded view of an embodiment of the configuration as typically shown by Figure 3 showing a first structural adhesive laminate 60 disposed between the electrical insulating sheet 54 and finned cover plate 52. The first adhesive laminate 60 is trimmed to match the outline of the finned cover plate 52 to bond the insulating sheet 54 to the cover plate 52. A second layer of  
10 structural adhesive laminate 58 is disposed between the top of the finned cover plate 52 and the back of the backing plate 50. The second laminate layer 58 has been trimmed (typically suspended from a carrying screen or mesh not shown) to match the surface pattern of the top of the fins 59 of the cooling passages so that only the surfaces intended to be in contact with each other are bonded (i.e., the  
15 top of the fins 59 and the border of the finned side of the cover plate 52). A solder layer 56 consisting of solder-material strips 0.010"-0.020" (0.25 mm-0.51mm) thick is disposed between the target material 48 and front of the backing plate 50. The solder layer 56 may also be formed by pre-wetting the target material 48 and front of the backing plate 50 using other means such as a)  
20 hot plate to dip the surfaces to be bonded in a pool of solder, b) brushing on the solder over the surfaces to be bonded, or c) sputter coating the surfaces to be bonded with a solder layer.

Figure 5 is an exploded view of another configuration as typically shown by Figure 3 showing another embodiment according to the invention. In some  
25 instances, to improve surface adhesion or wetting prior to attempting to make a solder bond, the surfaces to be solder bonded can be cleaned by sputter etching (bombarded with ions), and one or more layers of sputter coating material 65 can be sputter coated (deposited) onto the bonded side of the target material 48 and the backing plate 50 to pre-wet or tin their surfaces in preparation for soldering.

30 Another less reliable procedure involves conventionally pre-wetting the surfaces to

be solder bonded and scuffing the wetted solder prior to bonding to remove surface oxides. Once the surfaces to be bonded are tinned (pre-wetted), solder material strips 56, e.g. pure indium, and spacers 63 (e.g., pre-wetted 0.001"-0.010" (0.025mm-0.25mm) diameter copper wires) are positioned between the target material 48 and the backing plate 50 in preparation for solder bonding.

Figure 6 shows a close-up of a cross-section of Figure 3 near its edge consisting of the layers as shown in the embodiment of the invention shown in Figure 5. The backing plate 50 is a rectangular monolith, as generally described above, having a top target surface and a back surface. The top target surface, after having been sputter coated with an adhesion layer, can be wetted by sputtering pure indium on the backing plate 50 made of, for example, titanium. A target material 48 made of, for example, indium-tin-oxide (ITO) is also coated with an adhesion layer and can be wetted with a coating (e.g., pure indium) on its back surface. A series of alternating strips of solder 56 (e.g., strips 0.010"-0.020" (0.25 mm-0.51mm) thick of pure indium) and spacer 63 (e.g., pre-wetted 0.005"-0.010" (0.13mm-0.25mm) diameter copper wires) are positioned between the target material 48 and the backing plate 50. While a series of alternating spacers 63 and solder regions 56 with a high concentration are shown in Figure 6, such a high frequency of spacers 63 is not required. The spacers 63 provide a vertical spacing (preferably approximately 0.010" (0.25 mm)) so that after bonding of the target plate 48 to the backing plate 50, a spacer thickness solder joint is maintained. This extra thickness of the solder joint allows the solder material to readily plastically yield when subjected to a clamping pressure during the solder cooling cycle. The solder yielding avoids excessive distortion of the surface of the target material 48 due to a differential thermal expansion. Without spacers 63, the solder joint would have a much reduced thickness, e.g., less than 0.005" (0.13 mm), and thickness uniformity could not be controlled. Also, the excess solder from the thicker solder strips permits the surface oxide, which floats over the molten solder, to be forced out of the joint resulting in excellent solder bond coverage.

The finned cover plate 52 is covered with a layer of structural adhesive laminate 58 which has been trimmed with, for example, a razor blade to match the top of the exposed surfaces which will contact the back side of the backing plate 50. When the structural adhesive laminate 58 is cured, a good bond will create a tight seal between the cooling passages of the finned cover plate 52 and the backing plate 50. Thorough bonding of the ends of the fins of the cover plate 52 to the backing plate 50 will prevent ballooning of the cooling passages when cooling liquids under pressure are introduced into the cooling passages. An electrical insulating sheet 54 is bonded to the backside of the finned cover plate 52 by a structural adhesive laminate 60 similar to the structural adhesive laminate 58 used for the bond between the finned cover plate 52 and the backing plate 50.

Figures 7, 8, 9, and 10 provide easy visualization of the steps taken to position a multi-tiled target material (e.g., ITO) to be bonded to a backing plate 50 made of a material (e.g., titanium) with qualities compatible with the sputtering target material. As shown in Figure 7, because indium-tin-oxide is difficult to produce in large plates, when large plates of ITO are needed for sputtering, several tiles 49a, 49b, 49c are positioned adjacent to one another to provide full coverage for sputtering. The tiles are held adjacent to one another by an assembly frame (not shown). In Figure 8 the edges of the tiles and the target side of the tiles are covered with a high temperature polyamide flash breaker tape 43 to prevent the solder from wetting these surfaces. Also, the flash breaking tape 43 facilitates removal of solder material from the spaces between the panels thereby avoiding solder contamination when sputtering the finished target assembly 40.

Fig. 8A shows each tile's perimeter edge wrapped with polyimide tape 43a, 43b having a width equal to the thickness of the tile. The tiles (e.g. 49a, 49b) are placed adjacent to one another with a shim 45 maintaining the space between tiles. A joint forming flash breaker tape 43z is laid across two adjacent tiles 49a, 49b whose edges have been taped with polyamide tape 43a, 43b.

Fig. 8B shows the tiles 49a and 49b positioned in a plane ready to be mounted on the backing plate 50. A joint shim 47 positioned between tiles 49a,

49b maintains uniform spacing between tiles as the joint forming flash breaker tape 43z is bent around the joint shim 47 to a position where the tiles are adjacent to one another in a plane. Typically the thickness of the tape 43a, 43b, and 43z is 0.003" (0.076mm). Four layers of this tape, as seen in Figure 8B, provide a built-up thickness of 0.012" (0.30mm). Since it is desired that the final space between tiles be 0.015"-0.020" (0.38-0.51mm) when all tape and shims are removed, the thickness of the shim 47 should be between 0.003" and 0.008" (0.076" and 0.20mm). The shim 47 can be held in place until soldering is complete to assure uniform spacing between tiles. The height of the shim 47 is typically approximately 0.003" (0.076mm) less than the thickness of the tile. Once soldering is complete the shim 47 and all tape layers (43z, 43a, 43b) are removed to leave a 0.015"-0.020" (0.38-0.51mm) gap. Sputtering does not occur in this gap as it acts as a dark space shielded from the effects of sputtering.

Wetting or tinning of the back of the tiles 49a, 49b, and 49c can also take place, if necessary, at this time. A frame around the tiles is used to align and handle them before soldering takes place.

As can be seen in Figure 9, the target backing plate is prepared by positioning a series of solder panels 56 and spacers 63 adjacent to one another such that when the panels 49a, 49b, 49c are positioned over the solder panels (or strips) 56a and spacers 63 and heat is applied, the solder strips 56a will melt and solder will readily flow and bond the backing plate 50 to the target panel material 48 consisting of the tiles 49a, 49b, and 49c. Figure 10 shows the three-tile ITO target material 48 in position on the backing plate 50. The same process can be performed for monolithic target materials without joints. The number of spacers 63 and solder material strips 56 shown in Figure 9 is representative of the kind of spacing that is expected to be needed in order to maintain a generally uniform top surface without excessive deflection of the target material in the face of a uniform clamping pressure exerted by an autoclave. In the case of each pictured ITO tile (49a, b, c), the outer two spacers 63 would act as a bridge across which the tile, for example 49a, would span and deflect. Excessive deflection is not acceptable.

Therefore a middle spacer is provided. Further adjustments to the configuration can be made based on empirical measurements as needed.

A structural configuration for a finned backing plate 50a without epoxy cured bonds is shown in Figure 11. The finned backing plates 50a, 50b, 50c as shown in Figures 11, 12, 13, 14, and 15 include cover receiving recesses as, for example, can be seen in Figure 14 extending down from the top surface in the finned area. The cover plates 53a, b, c, d, or e match the size and thickness of the recess covering the cooling passages and fins 51 dividing and directing the cooling liquid flow from the inlet cooling passage openings to the outlet cooling passage openings. Figure 11 shows a two-piece cover, 53a and 53b, each panel symmetrical to the other along their common edge. Two separate cooling passage cavities are provided. Each cooling passage cavity and cover plate is separately welded by an edge weld (for example, 78) and a seam weld or a series of intermediate plug (or spot) welds 80 regularly located along the top of the fins 51 and the intermediate barrier 55 between adjacent cavities, although, it is possible to weld only some of the fins. Typically a seam weld is provided on the top of each fin 51. The finned plate 50a also includes a rough vacuum port 75, a power interlock port 74, and a power attachment fixture 76.

Figure 12 provides a cross-section of Figure 11 taken at 12-12.

Figure 13 provides an alternate configuration for a finned backing plate using a one-piece cover plate 53c. A welded finned backing plate 50b and cover 53c form a set of cooling fluid passages. A recess is made on the backing plate 50b to accept the thin cover 53c to hold the cooling fluid and all seams are welded shut. The one piece cover plate 53c is welded around its perimeter by a weld 72 and on the top of each fin, from end to end, by a seam weld 70.

Figure 14 is a close-up cross-sectional view of Figures 11, 13, and 15 showing typical weld locations and configurations.

Figure 15 shows an alternate configuration of a finned backing plate 50c where the cooling passages are separated by a thicker intermediate wall than in the prior embodiments, and are covered by separate cover plates 53d and 53e. A

perimeter weld 61 now also passes down the center axis of the finned backing plate 50c. Seam welds 62 are provided on the top of each cooling-passage fin. Seam welds are made over the fins to prevent the cover 53c from ballooning under pressure.

5           When using a backing plate (i.e., 50a, 50b, or 50c) of a weldable aluminum (e.g., aluminum alloy 6061), the recommended material for the thin cover (i.e., 53a, 53b, 53c, 53d, or 53e) is a silicon rich (9%-13% Si) aluminum alloy (e.g., aluminum alloy 4047 containing 11%-13% Si, an aluminum alloy used in the hybrid-package industry). Silicon rich aluminum is used to prevent  
10 fractures in the thin cover along the heat affected zone of the welds. Commercially pure titanium backing plates are welded to a thin cover of the same alloy.

          The preferred method of bonding the sputtering target assembly involves vacuum autoclave pressure bonding using two bags. Figure 16 is an exploded  
15 view showing the different layers included in a two vacuum (flexible) bag system configuration for bonding the target assembly. Figure 17 is a perspective view of the items of Figure 16 without showing the gas connectors. A bead of vacuum bag sealant 98, e.g., General Sealants, Inc. part no. 213 which is a high-temperature (350°F or 177°C) synthetic rubber tape, is attached to a tool (or  
20 support) plate 79. A sheet of non-perforated release film 100 is laid inside the area enclosed by the sealant 98 and is used to prevent the part (the sputtering target assembly 40) from bonding to the tool plate 79. Examples of the release film 100 are Airtech International, Inc. part no. Wrightlease 5900, a high-temperature PTFE release film used up to 650°F or 340°C, or Wrightlon  
25 5200 Blue, a fluorocarbon release film used up to 450°F or 230°C.

          The sputtering target assembly 40 is assembled as an unbonded sandwich according to Figure 16, with the side edges of the insulator sheet 54 wrapped with a flash breaker tape 49, the edges of the finned cover plate 52 wrapped with a flash breaker tape 44, the edges of the backing plate 50 wrapped with a flash  
30 breaker tape 42, and the backing plate border 78 up to the edge of the target

material 48 masked with a polyamide high-temperature tape coating 46. A plan view of the border coating 46 is shown in Figure 18.

5 Examples of flash breaker tapes that may be employed are the high tensile polyester films of fully cured silicon adhesive marketed by Airtech International, Inc. as Flashbreaker 1, 2, 5, the numerical designations referring to the thickness of the film (1, 2, and 5 mils thick respectively), and rated up to 400°F (205°C). Examples of polyamide tapes to mask the target material are manufactured by 3M under Scotch® brand 5413 and 5419 (low static) rated up to 500°F (260°C).

10 The assembled sputtering target assembly 40 is then placed over the release film 100 lying on the tool plate 79.

To form the lower vacuum bag system, a bead of vacuum bag sealant 102 is laid over the tape coating 46 covering the border of the backing plate 50 (target side). General Sealants, Inc. part no. 213 may be used; however, General Sealants, Inc. manufactures a variety of vacuum bag sealants rated by tackiness, 15 ability to remove clean after bonding, and temperature, whose use might be explored.

Inside the area enclosed by sealant 102, a release film 104, a bleeder film 106 and a breather mat 108 are laid over the target material 48.

20 Examples of the release film 104 that may be used are oil-free aluminum foil per ASTM B479 and uncoated polyamide film. These release films are used to protect the target surface from contaminants and to prevent bonding of the other films.

25 Examples of the bleeder film 106 are marketed by Airtech International, Inc. under Release Ply A and B, which are heat set and scoured uncoated nylon fabrics that can absorb excess bonding material. Their counterparts, Bleeder Lease A and B, are not used here in order to prevent contamination from a release agent used in these films.

30 Examples of the breather mat 108 are marketed by Airtech International, Inc. under Airweave N7 (a 7-oz. polyester breather and resin absorber) and Ultraweave 715 (a nylon 6-6 non-woven breather that does not seal off on

350°F/177°C cures). The breather material is required to facilitate nearly complete air evacuation from the vacuum bag.

Vacuum fitting bases 120 are laid over the breather mat 108 near the border of the backing plate 50 (see Figure 26 for a plan view of the locations of the gas connections). Nylon bag film 110, extending beyond the peripheries of a) the release and bleeder films 104 and 106, and b) mat 108, is laid over the assembly and pressed against vacuum sealant 102 to complete the lower vacuum bag system. Holes are made in the nylon bag film 110 to mate the vacuum fittings 92 and 94 to the bases 120.

Examples of nylon bag film 110 are marketed by Airtech International, Inc. under KM1300 rated 390°F/199°C and Wrightlon 7400 rated at the same temperature. These nylon films exhibit 300%+ elongation at break which allows the films to conform to the shape of the part without bridging, which can cause the bag to rupture and defeat the necessary pressure differential. Alternatively, a reusable silicon sheeting bag marketed by, for example, Zip-Vac, Inc., may be substituted for the vacuum bag film.

A typical vacuum fitting, e.g. 90 as shown in Figures 16, 21, and 23, is comprised of a base 120, and an upper assembly comprised of a seal 136 attached to a pressure plate 138, a male quick disconnect fitting 140, and a centrally located T-shaped pin 144 extending downwardly. The pin 144 of the upper assembly extends through a hole in the base and the arms of the pin engage opposite circular ramps on the bottom of the base as the upper assembly is twisted to tighten and seal the fitting 90 to the bag film 110.

The lower vacuum bag system is covered and enclosed with an upper vacuum bag system comprised principally of a release film 112, a bleeder film 114, a breather mat 116 and a vacuum bag film 118. The release and bleeder films 112 and 114, and the breather mat 116 extend beyond the periphery of the target assembly 40 but are laid inside the area enclosed by the bag sealant 98.

An example of release film 112 that may be used is marketed by Airtech International, Inc. under Release Ease 234 TFP, a porous release coated fiberglass



film rated at 550°F/285°C that will, according to the manufacturer, release from all commercial resin systems.

Examples of a bleeder film 114 are Release Ply A and B or Bleeder Lease A and B previously discussed.

5        Examples of a breather mat 116 are Airweave and Ultraweave 715 previously discussed.

Examples of a nylon bag film 118 are KM1300 and Wrightlon 7400, or the reusable silicon sheeting bag previously discussed.

10        During assembly of the upper vacuum bag system, bases 120 for the fittings 90 and 96 are laid over the breather mat 116 away from the side of the sputtering target assembly 40 (see location pictured in Figure 26), and nylon bag film 118 is laid over the assembly and pressed against vacuum bag sealant 98 to complete the upper vacuum bag system. Holes are made in the nylon bag film 118 to mate the fittings 90 and 96 to the bases 120.

15        Holes are provided in the upper bag system to allow the gas connections from the lower bag system to pass through the upper bag system while maintaining a separation between the upper and lower bag systems. Beads 119 and 121 (identified as 146 in Figure 27) of vacuum bag sealant (e.g., items 98 and 102 described above), applied inside the periphery of each opening, seal the openings  
20 and can expose the lower bag system around the gas fittings 92, 94 to the autoclave 88 pressure.

The tool plate 79 and attached elements are then placed into an autoclave 88 enclosure and the vacuum and gas supply fittings 81, 83, 85, 87 are connected. For example, vacuum disconnect fitting 87 connects to the male fitting 96 to pull a  
25 vacuum on the upper bag. Vacuum female fitting 81 connects to male fitting 90 to backfill the upper vacuum bag system with clean dry nitrogen when the autoclave pressure reaches approximately 1 atmosphere.

Figure 19 is a cross-sectional view of the double bagged layup (sandwich) after vacuum has been pulled inside the bags. All layers are now fully compressed  
30 against the contours of the sputtering target assembly (i.e., the part to be bonded);

no bridging exists. The sputtering target assembly 40 is disposed between a "Blanchard" ground tool plate 79 (to maintain flatness) and the double bagged vacuum system. Figures 20 and 21 provide a detailed close-up view of the features of Figure 19.

5           The autoclave 88 consists of a pressure vessel equipped with an internal heater and fan (not shown). The fan helps maintain a nearly constant fluid temperature inside the autoclave. Thermocouples 142 attached to the part 40 and tool plate 79 monitor the temperature inside the autoclave and provide input to a temperature controller (not shown) located outside the autoclave. This controller  
10 cycles the heater on and off in order to reach the desired temperature. The autoclave is pressurized by pumping nitrogen using a compressor (not shown) also located outside the autoclave. Vacuum lines, attached to a vacuum pump(s), enter the autoclave walls through sealed ports and provide vacuum to the bag(s) system. Similarly, gas lines, attached to gas bottle(s) on one end, enter the autoclave walls  
15 through sealed ports and are used to backfill the vacuum bag(s) system.

The autoclave "press" principle is to maintain a pressure differential, while heating or cooling, between the part 40, which starts under vacuum, and the outside atmosphere, which is at the autoclave pressure. The part 40, supported on one side by the tool plate 79, is subjected to a uniform autoclave pressure pressing  
20 against the vacuum bag. When the autoclave pressure reaches about 15 psi above atmosphere, enough pressure difference exists across the vacuum bag, vacuum pumping is stopped and the vacuum bag is backfilled with, for example, clean, dry nitrogen to avoid ingress of moist air or contaminants inside the bag. Alternately, a reducing, oxygen absorbing gas (i.e., carbon monoxide) can be used to eliminate  
25 the possibility of oxidizing parts at elevated temperatures. The autoclave pressure will continue to rise to the bonding pressure recommended by the specifications for use of the structural adhesives. The external side of the vacuum bag is pressurized at the autoclave pressure, for example 60 psi or whatever pressure is recommended, while the inside of the bag is maintained at atmospheric pressure  
30 (~ 15 psi). This pressure differential creates the pressure necessary to maintain

the parts to be bonded in intimate contact while the adhesive is curing. Usually, when the recommended curing pressure is reached, the autoclave will then be heated to the recommended curing temperature of the adhesive. For example:

1) Cyttec Engineered Materials, Inc. which manufactures Cybond EF-9500  
5 recommends a cure cycle having a 30 minute ramp at 6°F (3.3°C) per minute to go from ambient to 250°F ±5°F (120°C ±3°C), then holding for 90 minutes at 250°F ±5°F (120°C ±3°C) while the pressure is maintained at 60 psi ±5 psi (0.28 MPa ±0.03 MPa).

2) 3M Aerospace Materials which manufactures AF-191, a modified epoxy  
10 structural adhesive film, recommends a 4°F to 5°F (2°C to 3°C) per minute temperature rise to the cure temperature of 350°F ±5°F (177°C ±3°C), then holding for 60 minutes at 350°F ±5°F (177°C ±3°C) while the pressure is maintained at 45 psi ±5 psi.

15 Preferably, parts are to be cooled below 160°F (71°C) before removing from the autoclave 88 or venting to atmosphere.

The structural adhesive film and the components comprising the double bagged vacuum system are selected to withstand the melting point of the solder. For example, when indium solder is used (melting point of 156°C), the adhesive system is selected to withstand up to 350°F/177°C cure. Also, the vacuum bag  
20 components are selected to withstand 350°F/177°C, a temperature sufficiently high to ensure melting of the solder material.

Using a double bagged vacuum system, the target assembly 40 is fabricated by solder bonding and structural epoxy bonding in a single autoclave run. The manufacturer's cure procedure for the adhesive film is modified to accommodate  
25 the solder process. For example, when using indium solder and the above described Cybond EF-9500 structural adhesive, the autoclave is heated at a rate of 6°F (3.3°C) per minute to go from ambient to 350°F ±5°F (177°C ±3°C). This temperature will be maintained for approximately one minute to insure melting the indium solder strips 56 (shown in Figure 9). The autoclave is then cooled at a  
30 rate of approximately 9°F (5°C) per minute to 250°F ±5°F (120°C ±3°C) to

freeze the solder, then held for 60 minutes at  $250^{\circ}\text{F} \pm 5^{\circ}\text{F}$  ( $120^{\circ}\text{C} \pm 3^{\circ}\text{C}$ ) to fully cure the structural adhesive. The pressure is maintained at  $60 \text{ psi} \pm 5 \text{ psi}$  ( $0.28 \text{ MPa} \pm 0.03 \text{ Mpa}$ ) during the entire heating and cooling cycles. The lower vacuum bag system enclosing the solder is purged with a reducing gas (i.e.,  
5 carbon monoxide) to help reduce or eliminate the presence of oxygen and to improve the solder joint integrity (i.e., to avoid formation of indium oxide in the molten solder). In order to minimize oxidizing the solder, the solder strips 56, spacers 63, target material 48 and backing plate 50 (sides to be bonded only) are stripped of surface oxides and maintained in an inert gas atmosphere during the  
10 layup process. Other techniques such as ion bombardment (remove surface oxides) followed by sputtering a thin layer (one or two monolayers) of, for example, carbon may also be used. The carbon layer can react with oxygen to form a gas that can be pumped by the vacuum system attached to the lower vacuum bag.

15 Vacuum male fitting 94 (attached to the lower vacuum bag system) and vacuum female fitting 85 (attached to male fitting 94 and to a hose which exits the autoclave 88 and attaches to a line that splits into two valved lines -- one going to a vacuum pump and the other to a vent) connect to the lower vacuum bag system enclosing the target material 48, a portion of the backing plate 50, and the solder  
20 material 56 disposed between them (refer to Figure 5). Similarly, mating fittings 92 and 83 connect to a valved gas supply outside the autoclave 88. Although not shown, more than one set of vacuum lines may be attached to each vacuum bag system to increase vacuum pumping or purging of the bag.

Vacuum male fitting 96 (attached to the upper vacuum bag system) and  
25 vacuum female fitting 87 (attached to male fitting 96 and to a hose which exits the autoclave and attaches to a line that splits into two valved lines -- one going to a vacuum pump and the other to a vent) connect to the upper vacuum bag system enclosing a) the target backing plate assembly (enclosed by the lower vacuum bag), the finned cover 52 and the adhesive 58 disposed between them; and b) the  
30 finned cover 52, the electrical insulating sheet 54 and the adhesive 60 disposed

between them.

When the pressure in the autoclave 88 reaches 15 psi (for reasons previously described), the valves to the vacuum pump(s) are closed and the valves to the gas lines are opened to bring the pressure inside the vacuum bag to approximately 15 psi or 1 atmosphere of the appropriate gas, i.e., an inert or oxygen-absorbing (getter) gas. When pressure inside the vacuum bag reaches approximately 1 atmosphere, the vent valves on the vacuum pump hoses are opened once and then closed to purge the vent lines and leave the vacuum bags saturated with the vent/purge gas.

For example, carbon monoxide gas may be introduced into the lower vacuum bag system via a hose attached to female fitting 83 which attaches to male fitting 92. As previously discussed, carbon monoxide is used here to absorb free oxygen and to maintain the cleanest possible environment for the solder bond. Clean, dry nitrogen is introduced into the upper vacuum bag system via a hose attached to female fitting 81 which attaches to male fitting 90 to avoid ingress of moist air or contaminants while the structural adhesive laminates cure.

Figure 22 shows an example of routing a thermocouple wire 142 through the bag seal 98 of a vacuum bag system barrier film 118. Typically at least two thermocouples are provided to each target assembly in an autoclave 88 and the temperature of the target material 48 serves as input to the temperature controller to cycle the autoclave heater on and off.

Figure 23 shows a side view of a typical male fitting (i.e., items 90, 92, 94, and 96) connection through a barrier film of a vacuum bag (i.e., items 110 or 118). Using, for example, a razor blade, a hole is made on the vacuum bag to permit pin 144 extending downwardly to engage the base 120. A seal is made by the rubber seal 136; however, leaky connections are often repaired by sealing the connection using vacuum sealant (e.g., items 98 or 102.)

Figure 24 is an exploded view showing the different layers comprising a single vacuum bag system. Vacuum bag sealant 98 is pressed against tool plate 79 (it will later form a vacuum seal with the nylon bag film 118). The assembled

sputtering target assembly 40 is placed over the release film 100 lying on the tool plate 79 and enclosed by the sealant 98. A release film 112, a bleeder film 114 and a breather mat 116 are laid over the sputtering target assembly 40. Vacuum fitting bases 120 are laid over the breather mat 116 away from the sputtering target assembly 40, and nylon bag film 118 is laid over the assembly and pressed against vacuum sealant 98 to complete the vacuum bag system. Holes are made in the nylon bag film 118 to mate the fittings 90 and 96 to the bases 120, all similar to the two bag system described above.

Figure 25 is a cross-sectional view of a single bagged vacuum system layout described in Figure 24 after vacuum has been pulled inside the bags. A double bagged system is useful for solder and epoxy bonding in a single autoclave run; but a single bagged system is useful for: (a) enclosing the whole assembly in a vacuum bag system to cure the adhesive bonded surfaces in the autoclave 88 while, at the same time, stress relieving and flattening the previously soldered target/backing plate sub-assembly; (b) solder bonding the target/backing plate sub-assembly in the autoclave first; the cover to hold the cooling fluid may be attached later by means of fasteners sealed by O-ring seals; (c) solder bonding the target/backing plate sub-assembly in the autoclave after a finned backing plate and cover which holds the cooling fluid have been welded (e.g., laser or electron beam welded); or (d) solder bonding a new target material 48 to refurbish a target assembly 40 ("backing plate" recycle method) fabricated by any of the previously described methods.

Figure 26, as discussed above when discussing Figure 16, shows the location of the sputtering target assembly 40 on the tool plate 79 showing the routing of the sealant 98 and 102 on the tool plate 79 and the border of the backing plate 50, respectively. The hoses connecting to the gas passage fittings 81, 83, 85 and 87 are also shown.

Figure 27, as previously discussed when discussing Figure 16, shows a typical opening in the barrier film 118 of the upper bag sealed by a bead of sealant 146 to expose the gas connection fitting 92 to the lower bag film barrier 110.

Autoclaving is a well-known and economical technology. Nonetheless, the autoclave processes described above provide a unique, dependable, and efficient method of producing a sputtering target assembly. It is of course possible to achieve the required temperature and pressure by means other than an autoclave.

5 While the invention has been described with regard to specific embodiments, those skilled in the art will recognize that changes can be made in form and detail without departing from the spirit and scope of the invention.

**CLAIMS**

1. A method for producing a sputtering target assembly, comprising the steps of:

5 providing the components of a sputtering target assembly assembled in an unbonded sandwich, at least two layers of said unbonded sandwich being separated by a bonding layer;

pressing the layers of the unbonded sandwich together using a source of pressure which provides a generally uniform pressure distribution across the top and bottom surfaces of said unbonded sandwich;

10 raising the temperature of the unbonded sandwich above a predetermined bonding temperature of said bonding layer while maintaining pressure on said layers;

maintaining the temperature and pressure on the layers of said unbonded sandwich above said bonding temperature for the duration of a predetermined bond curing time; and

15 maintaining the pressure on the unbonded sandwich while the temperature of the unbonded sandwich falls to a predetermined process completion temperature.

20 2. A method for producing a sputtering target assembly as in Claim 1 further comprising,

enclosing the unbonded sandwich in a flexible vacuum tight enclosure;

creating a vacuum pressure within the flexible vacuum tight enclosure, thus forming a vacuum encapsulated unbonded sandwich assembly; and

25 wherein the pressing step includes pressurizing the flexible vacuum tight enclosure and vacuum encapsulated unbonded sandwich assembly in a pressure chamber; and

wherein the steps of raising the temperature, maintaining the temperature, and maintaining the pressure are all performed in a pressure chamber.

30



3. A method for producing a sputtering target assembly as in Claim 2,  
wherein the enclosing step includes supporting said unbonded sandwich on  
a support plate and covering and sealing the unbonded sandwich with a flexible  
vacuum tight covering sealed to the support plate.
- 5
4. A method of producing a sputtering target assembly as in Claim 2,  
wherein the enclosing step includes a target backing plate supporting a  
target member of said unbonded sandwich on a target backing plate and sealing a  
flexible vacuum tight covering covering the target member of said unbonded  
10 sandwich to the target backing plate.
5. A method for producing a sputtering target assembly, comprising the steps  
of:
- 15 laminating the components of a sputtering target assembly in an unbonded  
sandwich on a support plate, at least two layers of said unbonded sandwich being  
separated by a bonding layer;
- covering the unbonded sandwich on the support plate with an upper flexible  
vacuum tight covering sealed to the support plate thus forming a vacuum  
encapsulated unbonded sandwich assembly;
- 20 creating a vacuum pressure within the upper flexible vacuum tight covering  
over the unbonded sandwich and the support plate;
- pressurizing the support plate and vacuum encapsulated unbonded sandwich  
assembly in a pressure chamber;
- raising the temperature of the vacuum encapsulated unbonded sandwich  
25 assembly in the pressure chamber above a predetermined bonding temperature of  
said bonding layer;
- maintaining the temperature and pressure on the vacuum encapsulated  
unbonded sandwich assembly in the pressure chamber above the bonding  
temperature for the duration of a predetermined bond curing time;
- 30 maintaining the pressure on the support plate and vacuum encapsulated

unbonded sandwich assembly while the temperature of the vacuum encapsulated unbonded sandwich assembly falls to a predetermined process completion temperature.

- 5 6. A method for producing a sputtering target assembly, as in Claim 5,  
wherein the step of covering the unbonded sandwich further includes  
covering a target material with a lower flexible vacuum tight covering and sealing  
the lower covering to a target backing plate of said unbonded sandwich inside said  
upper flexible vacuum tight covering;
- 10 wherein the step of creating a vacuum pressure includes creating a vacuum  
pressure within the lower flexible vacuum tight covering over the target material  
and the target backing plate.
7. A method for producing a sputtering target assembly, as in Claim 5,  
15 wherein the laminating step includes disposing a release film between the  
unbonded sandwich and the support plate.
8. A method for producing a sputtering target assembly as in Claim 5;  
wherein the laminating step includes placing a solder material in spaces  
20 between spacer members disposed to maintain a predefined clearance between a  
sputtering target material and the backing plate when the solder melts.
9. A method for producing a sputtering target assembly as in Claim 6;  
wherein the laminating step includes placing a solder material in spaces  
25 between spacer members disposed to maintain a predefined clearance between a  
sputtering target material and the backing plate when the solder melts.
10. A method for producing a sputtering target assembly as in Claim 5 further  
comprising;  
30 wherein activity prior to the laminating step includes sputter depositing the

back side of a target material with a solder material to act as tinning in preparation for subsequent solder bonding of said target to a backing plate when a bonding temperature is achieved in the subsequent step of raising the temperature of the vacuum encapsulated unbonded sandwich assembly.

5

11. A method for producing a sputtering target assembly as in Claim 6; wherein activity prior to the laminating includes sputter depositing the back side of a target material with a solder material to act as tinning in preparation for subsequent solder bonding of said target to a backing plate when a bonding temperature is achieved in the subsequent step of raising the temperature of the vacuum encapsulated unbonded sandwich assembly.

10

12. A method for producing a sputtering target assembly as in Claim 10; wherein prior to sputter depositing the back side of a target material with a solder material, the back side is sputter etched.

15

13. A method for producing a sputtering target assembly as in Claim 11; wherein prior to sputter depositing the back side of a target material with a solder material, the back side is sputter etched.

20

14. A method for producing a sputtering target assembly, as in Claim 7, wherein the step of providing the components of a sputtering target assembly further includes providing a breather mat film over said unbonded sandwich disposed between the unbonded sandwich and the upper flexible vacuum tight covering.

25

15. A method for producing a sputtering target assembly, as in Claim 7, wherein the step of providing the components of a sputtering target assembly further includes sequentially providing a release film, a bleeder film, and a breather mat film over said unbonded sandwich disposed between the unbonded

30

sandwich and the upper flexible vacuum tight covering.

16. A method for producing a sputtering target assembly as in Claim 1,  
wherein the step of providing the components includes a target backing  
5 plate as a component of the unbonded sandwich said backing plate having been  
produced by a method including the steps of:  
providing a finned target backing plate including a void forming a set of  
cooling fluid passages in said plate, said void including a series of fins, each fin  
having a top surface;  
10 putting a cover in place over said void;  
seal welding the edges of said cover to said backing plate to seal said void;  
and  
spot or seam welding said cover to the tops of said fins in a predetermined  
weld pattern.
- 15 17. A method for producing a sputtering target assembly, comprising the steps  
of:  
providing a finned target backing plate including a void forming a set of  
cooling fluid passages in said plate, said void including a series of fins, each fin  
20 having a top surface;  
putting a cover in place over said void;  
seal welding the edges of said cover to said backing plate to seal said void;  
and  
spot or seam welding said cover to the tops of said fins in a predetermined  
25 weld pattern.
18. A method for producing a sputtering target assembly as in Claim 17,  
wherein said cover is a silicon rich (7%-14% Si) aluminum alloy.
- 30 19. A method for producing a sputtering target assembly as in Claim 17,

wherein said backing plate is a weldable aluminum alloy.

20. A method for producing a sputtering target assembly as in Claim 17,  
 wherein said backing plate and cover are a weldable titanium alloy or  
 5 commercially pure titanium.

21. A method of fabricating a sputtering target assembly, comprising the steps  
 of:

10 applying a bonding agent to a surface of a first of a plurality of generally  
 planar panels, one of which comprises a sputtering target;

laminating together said plurality of panels, said surface of said first panels  
 facing a surface of a second of said panels, said first and second panels  
 constituting a first pair of panels;

15 a first step of exerting a differential hydrostatic pressure across at least  
 some of said laminated panels including said first pair pressing a first of said  
 panels toward said second of said panels; and

20 during said first exerting step, heating said laminated panels to a first  
 temperature, whereby said bonding agent causes said first pair of panels to be  
 bonded together.

22. A method as recited in Claim 21, wherein said bonding agent is a solder.

23. A method as recited in Claim 22, wherein said bonding agent is an  
 adhesive.

25 24. A method as recited in Claim 21, wherein said plurality of panels  
 comprises at least three of said panels and wherein said first exerting step exerts  
 said differential hydrostatic pressure across only some of said panels including said  
 first pair.

30

25. A method as recited in claim 24,  
wherein said bonding agent comprises a solder; and  
further comprising applying an adhesive to a third surface of one of said  
second pair of panels, said third surface facing the other of said second pair of  
5 panels; and  
wherein said first exerting step exerts said differential hydrostatic pressure  
across said first pair; and  
further comprising:  
a second step of exerting said differential hydrostatic pressure across at  
10 least some of said panels including said second pair; and  
during said second exerting step, heating said laminated panels to a second  
temperature lower than said first temperature, whereby said adhesive causes said  
second pair of panels to be bonded together.
- 15 26. A method as recited in Claim 21, wherein said differential hydrostatic  
pressure is a differential gaseous pressure.
26. A method as recited in Claim 21, wherein one of said first pair of panels  
includes a surface having grooves for forming fluid cooling channels in said  
20 sputtering target assembly.
27. A method of Claim 1;  
wherein the sputtering target material includes tiles with one or more joints  
between them and the joints are sealed during soldering by use of a flexible tape  
25 sealed to an edge of each tile and bridging said one or more joints to prevent  
solder from flowing from the backing plate surface into said one or more joints.

## AMENDED CLAIMS

[received by the International Bureau on 12 April 1996 (12.04.96);  
original claims 1-27 replaced by amended claims 1-46 (11 pages)]

1. A method for producing a sputtering target assembly, comprising the steps of:
  - providing the components of a sputtering target assembly assembled in an  
5 unbonded sandwich, at least two layers of said unbonded sandwich being separated  
by a bonding layer;
    - pressing the layers of the unbonded sandwich together using a source of  
pressure which provides a generally uniform pressure distribution across the top  
and bottom surfaces of said unbonded sandwich;
    - 10 raising the temperature of the unbonded sandwich above a bonding  
temperature of said bonding layer while maintaining pressure on said layers;
      - maintaining the temperature and pressure on the layers of said unbonded  
sandwich above said bonding temperature for the duration of a bond completion  
time; and
      - 15 maintaining the pressure on the unbonded sandwich while the temperature  
of the unbonded sandwich falls to a process completion temperature.
2. A method for producing a sputtering target assembly as in Claim 1 further  
comprising,
  - 20 enclosing the unbonded sandwich in a flexible vacuum tight enclosure;
    - creating a vacuum pressure within the flexible vacuum tight enclosure, thus  
forming a vacuum encapsulated unbonded sandwich assembly; and
    - wherein the pressing step includes pressurizing the flexible vacuum tight  
enclosure and vacuum encapsulated unbonded sandwich assembly in a pressure  
25 chamber; and
    - wherein the steps of raising the temperature, maintaining the temperature,  
and maintaining the pressure are all performed in a pressure chamber.
3. A method for producing a sputtering target assembly as in Claim 2,  
30 wherein the enclosing step includes supporting said unbonded sandwich on a

3. A method for producing a sputtering target assembly as in Claim 2,  
wherein the enclosing step includes supporting said unbonded sandwich on  
a support plate and covering and sealing the unbonded sandwich with a flexible  
vacuum tight covering sealed to the support plate.
- 5
4. A method of producing a sputtering target assembly as in Claim 2,  
wherein the enclosing step includes a target backing plate supporting a  
target member of said unbonded sandwich on a target backing plate and sealing a  
flexible vacuum tight covering covering the target member of said unbonded  
10 sandwich to the target backing plate.
5. A method for producing a sputtering target assembly, comprising the steps  
of:
- 15 laminating the components of a sputtering target assembly in an unbonded  
sandwich on a support plate, at least two layers of said unbonded sandwich being  
separated by a bonding layer;
- covering the unbonded sandwich on the support plate with an upper flexible  
vacuum tight covering sealed to the support plate thus forming a vacuum  
encapsulated unbonded sandwich assembly;
- 20 creating a vacuum pressure within the upper flexible vacuum tight covering  
over the unbonded sandwich and the support plate;
- pressurizing the support plate and vacuum encapsulated unbonded sandwich  
assembly in a pressure chamber;
- raising the temperature of the vacuum encapsulated unbonded sandwich  
25 assembly in the pressure chamber above a predetermined bonding temperature of  
said bonding layer;
- maintaining the temperature and pressure on the vacuum encapsulated  
unbonded sandwich assembly in the pressure chamber above the bonding  
temperature for the duration of a predetermined bond curing time;
- 30 maintaining the pressure on the support plate and vacuum encapsulated



6. A method for producing a sputtering target assembly, as in Claim 5,  
wherein the step of covering the unbonded sandwich further includes  
covering a target material with a lower flexible vacuum tight cover and sealing the  
lower flexible vacuum tight cover to a target backing plate of said unbonded  
5 sandwich inside said upper flexible vacuum tight cover;  
wherein the step of creating a vacuum pressure includes creating a vacuum  
pressure within the lower flexible vacuum tight cover over the target material and  
the target backing plate.
- 10 7. A method for producing a sputtering target assembly, as in Claim 5,  
wherein the laminating step includes disposing a first release film between  
the unbonded sandwich and the support plate.
8. A method for producing a sputtering target assembly as in Claim 5;  
15 wherein the laminating step includes placing a solder material in spaces  
between spacer members disposed to maintain a predefined clearance between a  
sputtering target material and the backing plate when the solder melts.
9. A method for producing a sputtering target assembly as in Claim 6;  
20 wherein the laminating step includes placing a solder material in spaces  
between spacer members disposed to maintain a predefined clearance between the  
sputtering target material and the backing plate when the solder melts.
10. A method for producing a sputtering target assembly as in Claim 5 further  
25 comprising;  
wherein activity prior to the laminating step includes sputter depositing the  
back side of a target material with a solder material to act as tinning in preparation  
for subsequent solder bonding of said target to a backing plate when a bonding  
temperature is achieved in the subsequent step of raising the temperature of the  
30 vacuum encapsulated unbonded sandwich assembly.

11. A method for producing a sputtering target assembly as in Claim 6;  
wherein activity prior to the laminating includes sputter depositing the back  
side of a target material with a solder material to act as tinning in preparation for  
subsequent solder bonding of said target to a backing plate when a bonding  
5 temperature is achieved in the subsequent step of raising the temperature of the  
vacuum encapsulated unbonded sandwich assembly.
12. A method for producing a sputtering target assembly as in Claim 10;  
wherein prior to sputter depositing the back side of a target material with a  
10 solder material, the back side is sputter etched.
13. A method for producing a sputtering target assembly as in Claim 11;  
wherein prior to sputter depositing the back side of a target material with a  
solder material, the back side is sputter etched.  
15
14. A method for producing a sputtering target assembly, as in Claim 7,  
wherein the step of providing the components of a sputtering target  
assembly further includes providing a breather mat film over said unbonded  
sandwich disposed between the unbonded sandwich and the upper flexible vacuum  
20 tight cover.
15. A method for producing a sputtering target assembly, as in Claim 7,  
wherein the step of providing the components of a sputtering target  
assembly further includes sequentially providing a second release film, a bleeder  
25 film, and a breather mat film over said unbonded sandwich disposed between the  
unbonded sandwich and the upper flexible vacuum tight cover.
16. A method for producing a sputtering target assembly as in Claim 1,  
wherein the step of providing the components includes a target backing  
30 plate as a component of the unbonded sandwich said backing plate having been

produced by a method including the steps of:

providing a finned target backing plate including a void forming a set of cooling fluid passages in said plate, said void including a series of fins, each fin having a top surface;

- 5        putting a cover in place over said void;  
         seal welding the edges of said cover to said backing plate to seal said void;  
         and  
         spot or seam welding said cover to the tops of said fins.

- 10    17.    A method for producing a sputtering target assembly, comprising the steps of:

         providing a finned target backing plate including a void forming a set of cooling fluid passages in said plate, said void including a series of fins, each fin having a top surface;

- 15        putting a cover in place over said void;  
         seal welding the edges of said cover to said backing plate to seal said void;  
         and  
         spot or seam welding said cover to the tops of said fins.

- 20    18.    A method for producing a sputtering target assembly as in Claim 17, wherein said cover is a silicon rich (7%-14% Si) aluminum alloy.

19.    A method for producing a sputtering target assembly as in Claim 17, wherein said backing plate is a weldable aluminum alloy.

- 25        20.    A method for producing a sputtering target assembly as in Claim 17, wherein said backing plate and cover are a weldable titanium alloy or commercially pure titanium.

- 30    21.    A method of fabricating a sputtering target assembly, comprising the steps

of:

applying a bonding agent to a surface of a first of a plurality of generally planar panels, one of which comprises a sputtering target;

5 locating said plurality of panels together, said surface of said first of said plurality of panels facing a surface of a second of said plurality of panels, said first and second of said plurality of panels constituting a first pair of panels;

exerting a first pressure across at least two or more of said plurality of panels including said first pair, said first pressure pressing said first of said panels toward said second of said panels; and

10 simultaneously with exerting said first pressure, heating at least said first and second of said plurality of panels to a first temperature at which said bonding agent causes said first pair of panels to be bonded together.

22. A method as recited in Claim 21, wherein said bonding agent is a solder.  
15

23. A method as recited in Claim 22, wherein said bonding agent is an adhesive.

24. A method as recited in Claim 21, wherein said plurality of panels comprises  
20 at least three of said panels and wherein said first pressure exerts pressure across at least two of said panels including said first pair.

25. A method as recited in claim 24,  
wherein said bonding agent comprises a solder; and  
25 further comprising applying an adhesive to a third surface of one of a second pair of panels, said second and a third of said plurality of panels comprising said second pair, said third surface facing a fourth surface of said second pair of panels; and

30 wherein said first pressure exerts a first force pressing said first pair of panels together; and

further comprising:

exerting a second pressure across at least two of said panels including said second pair; and

5 simultaneously with exerting said second pressure, heating at least said second and third of said plurality of panels to a second temperature lower than said first temperature, at which said adhesive causes said second pair of panels to be bonded together.

26. A method as recited in Claim 21, wherein said differential hydrostatic  
10 pressure is a differential gaseous pressure.

27. A method of Claim 1;  
wherein at least one of said layers includes a set of tiles with one or more joints between them and the joints are sealed during soldering by use of a flexible  
15 tape sealed to an edge of each tile and bridging said one or more joints to prevent solder from flowing from the backing plate surface into said one or more joints.

28. A method for producing a sputtering target assembly, comprising the steps of:  
20 providing the components of a sputtering target assembly assembled in an bonded sandwich, at least two layers of said bonded sandwich being separated by a bonding layer;  
pressing the layers of the unbonded sandwich together using a source of pressure which provides a generally uniform pressure distribution across the top  
25 and bottom surfaces of said bonded sandwich;  
raising the temperature of the bonded sandwich to a stress relieving temperature of said bonding layer;  
continuing pressing the layers together and maintaining the temperature of said unbonded sandwich at said stress relieving temperature for the duration of a  
30 stress relieving time; and

continuing pressing the layers of the bonded sandwich together while the temperature of the bonded sandwich falls to a stress relief process completion temperature.

- 5 29. A method for producing a sputtering target assembly, as in Claim 1, wherein during the steps of: providing, pressing, raising, and maintaining the temperature; said components are exposed to a substantially inert gas environment.
- 10 30. A method for producing a sputtering target assembly, as in Claim 1, wherein during the steps of: providing, pressing, raising, and maintaining the temperature; said components are exposed to a substantially moisture free and inert gas environment.
- 15 31. A method for producing a sputtering target assembly, as in Claim 1, wherein during the steps of: providing, pressing, raising, and maintaining the temperature; said components are exposed to a substantially oxygen absorbing gas environment.
- 20 32. A method for producing a sputtering target assembly, as in Claim 1, wherein during the steps of: providing, pressing, raising, maintaining the temperature, and maintaining the pressure; said components are enclosed in a gas tight enclosure having a flexible wall, said enclosure containing a substantially inert gas environment.
- 25 33. A method for producing a sputtering target assembly, as in Claim 1, wherein during the steps of: providing, pressing, raising, maintaining the temperature, and maintaining the pressure; said components are enclosed in a gas tight enclosure having a flexible wall, said enclosure containing a substantially
- 30 moisture free inert gas environment.

34. A method for producing a sputtering target assembly, as in Claim 1,  
wherein during the steps of: providing, pressing, raising, maintaining the  
temperature, and maintaining the pressure; said components are enclosed in a gas  
tight enclosure having a flexible wall, said enclosure containing a substantially  
oxygen absorbing gas environment.
35. A method for producing a sputtering target assembly, as in Claim 34,  
wherein the substantially oxygen absorbing gas environment is formed  
primarily with carbon monoxide.
36. A method for producing a sputtering target assembly, as in Claim 32,  
wherein before providing a substantially inert gas environment to the gas  
tight enclosure said enclosure has been substantially evacuated.
37. A method for producing a sputtering target assembly, as in Claim 33,  
wherein before providing a substantially inert gas environment to the gas  
tight enclosure said enclosure has been substantially evacuated.
38. A method for producing a sputtering target assembly, as in Claim 34,  
wherein before providing a substantially inert gas environment to the gas  
tight enclosure said enclosure has been substantially evacuated.
39. A method for producing a sputtering target assembly, as in Claim 1,  
wherein the step of providing the components includes providing a surface  
of at least one of the faces of said layers facing one another and being separated by  
a bonding layer having been coated by sputter depositing a layer of said bonding  
material thereon.
40. A method for producing a sputtering target assembly, as in Claim 29,  
wherein the step of providing the components includes providing a surface

of at least one of the faces of said layers facing one another and being separated by a bonding layer having been coated by sputter depositing a layer of said bonding material thereon.

- 5 41. A method for producing a sputtering target assembly, as in Claim 30,  
wherein the step of providing the components includes providing a surface  
of at least one of the faces of said layers facing one another and being separated by  
a bonding layer having been coated by sputter depositing a layer of said bonding  
material thereon.
- 10 42. A method for producing a sputtering target assembly, as in Claim 31,  
wherein the step of providing the components includes providing a surface  
of at least one of the faces of said layers facing one another and being separated by  
a bonding layer having been coated by sputter depositing a layer of said bonding  
15 material thereon.
43. A method as recited in Claim 21, wherein one of said first pair of panels  
includes a surface having grooves for forming fluid cooling channels in said  
sputtering target assembly.
- 20 44. A method for producing a sputtering target assembly as in Claim 1;  
wherein the step of providing the components for the bonding layer includes  
placing a solder material in spaces between spacer members disposed to maintain a  
predefined clearance between at least two layers of said unbonded sandwich when  
25 the solder melts.
45. A method for producing a sputtering target assembly as in Claim 1;  
wherein activity prior to the step providing the components includes sputter  
depositing bonding side of a first of said at least two layers with a solder material  
30 to act as tinning in preparation for subsequent solder bonding of said first of said at



## STATEMENT UNDER ARTICLE 19

- Claims 1 and 5 the word "predetermined" has been deleted from before the words "bonding temperature"; the words "predetermined bond curing" have been replaced by the words "bond completion"; and the word "predetermined" has been deleted from before the words "process completion."
  - Once in each Claim 3, 4, 14, and 15; twice in Claim 5; and three times in Claim 6 the words "flexible vacuum tight covering" have been changed to "flexible vacuum tight cover" to increase clarity and avoid confusion with the method step of "covering" (a verb). The noun "covering" in the specification and in the claims is considered synonymous with the noun "cover."
  - In Claim 6 the wording "lower covering" has been changed to "lower flexible vacuum tight cover."
  - In Claim 7 the word "first" has been inserted before the words "release film."
  - In Claim 9 the words "between a" have been revised to "between the."
  - In Claim 15 the word "second" has been inserted before the words "release film."
  - In Claims 16 and 17 the words "in a predetermined weld pattern" have been deleted.
  - In Claim 21, 24, 25, and 27 numerous changes in wording have made. Portions of the changes to the text are shown as follows added text is shown underlined, while [deleted text is shown in brackets].
21. . . .  
locating [laminating together] said plurality of panels together, . . . first of

21. . . .  
locating [laminating together] said plurality of panels together, . . . first of said plurality of panels . . . said plurality of panels, . . . second of said plurality of panels . . .  
exerting a first [step of exerting a differential hydrostatic] pressure across at least [some] two or more of said [laminated] plurality of panels including said first pair, said first pressure pressing [a] said first . . .  
[during said first] simultaneously with exerting said first pressure [step], heating at least said first and second of said [laminated] plurality of panels to a first temperature[, whereby] at which said bonding . . .

25. . . .  
. . . one of [said] a second pair of panels, said second and a third of said plurality of panels comprising said second pair, said third surface facing a fourth [the other] surface of said . . .  
wherein said first pressure [said first exerting step] exerts [said differential hydrostatic pressure across] a first force pressing said first pair of panels together . . .  
. . .  
exerting a second [step of exerting said differential hydrostatic] pressure . . . least [some] two of said . . .  
[during said second] simultaneously with exerting said second pressure [step], heating at least said second and third of said [laminated] plurality of panels . . . temperature, [whereby] at which said adhesive . . .

27. . . .  
wherein at least one of said layers [the sputtering target material] includes a set of tiles . . .

- Two Claims numbered 26 were initially submitted. The first remains unchanged. The second has been cancelled.
- Claims 28 to 46 are new.

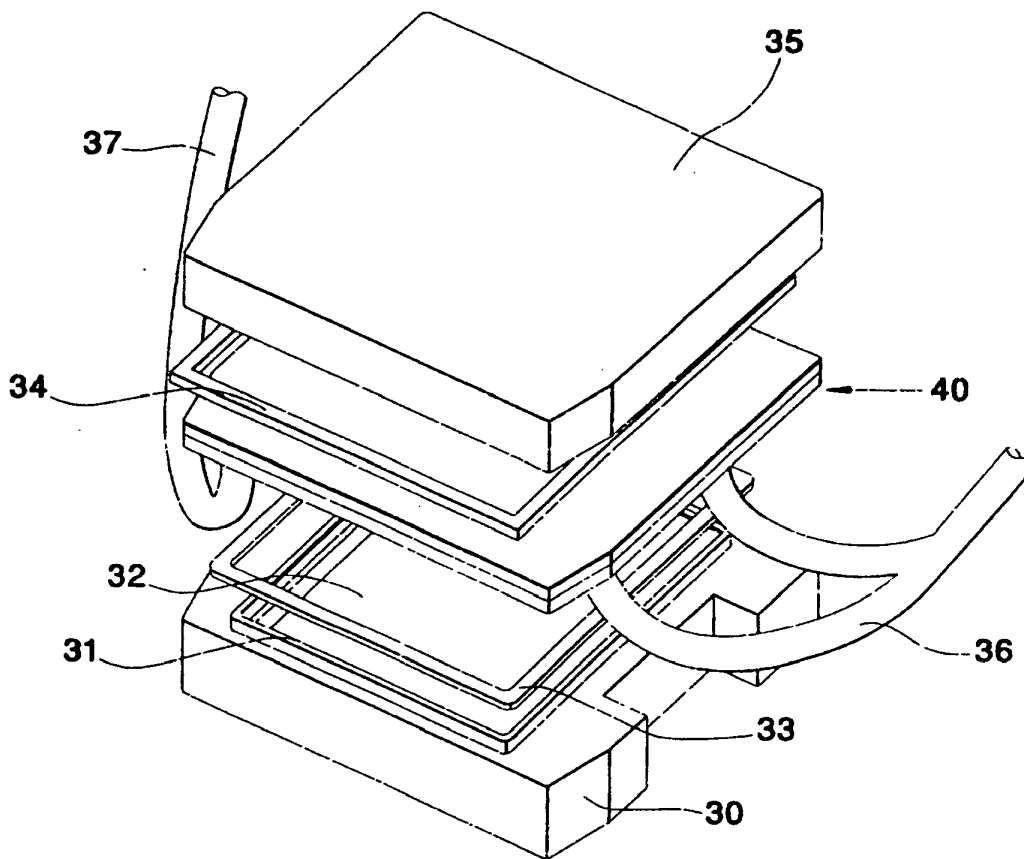


Fig. 1

**SUBSTITUTE SHEET (RULE 26)**

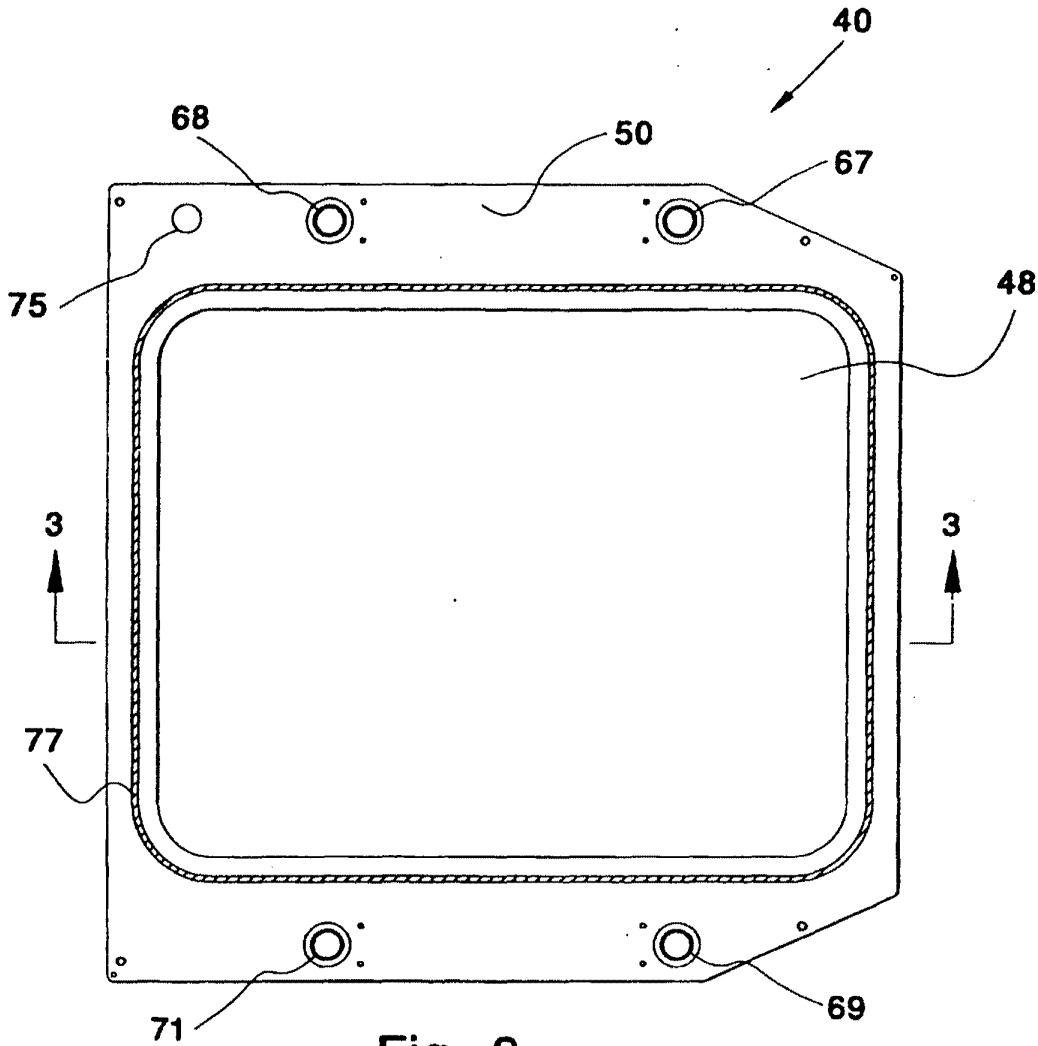


Fig. 2

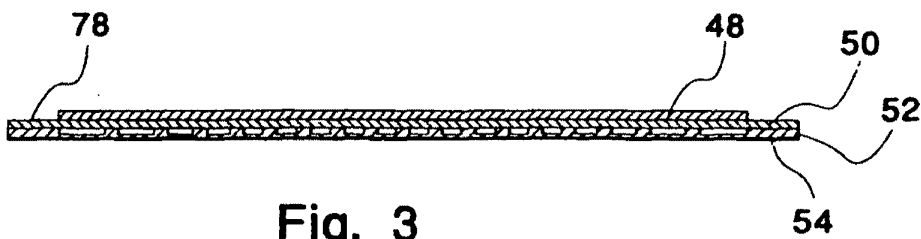
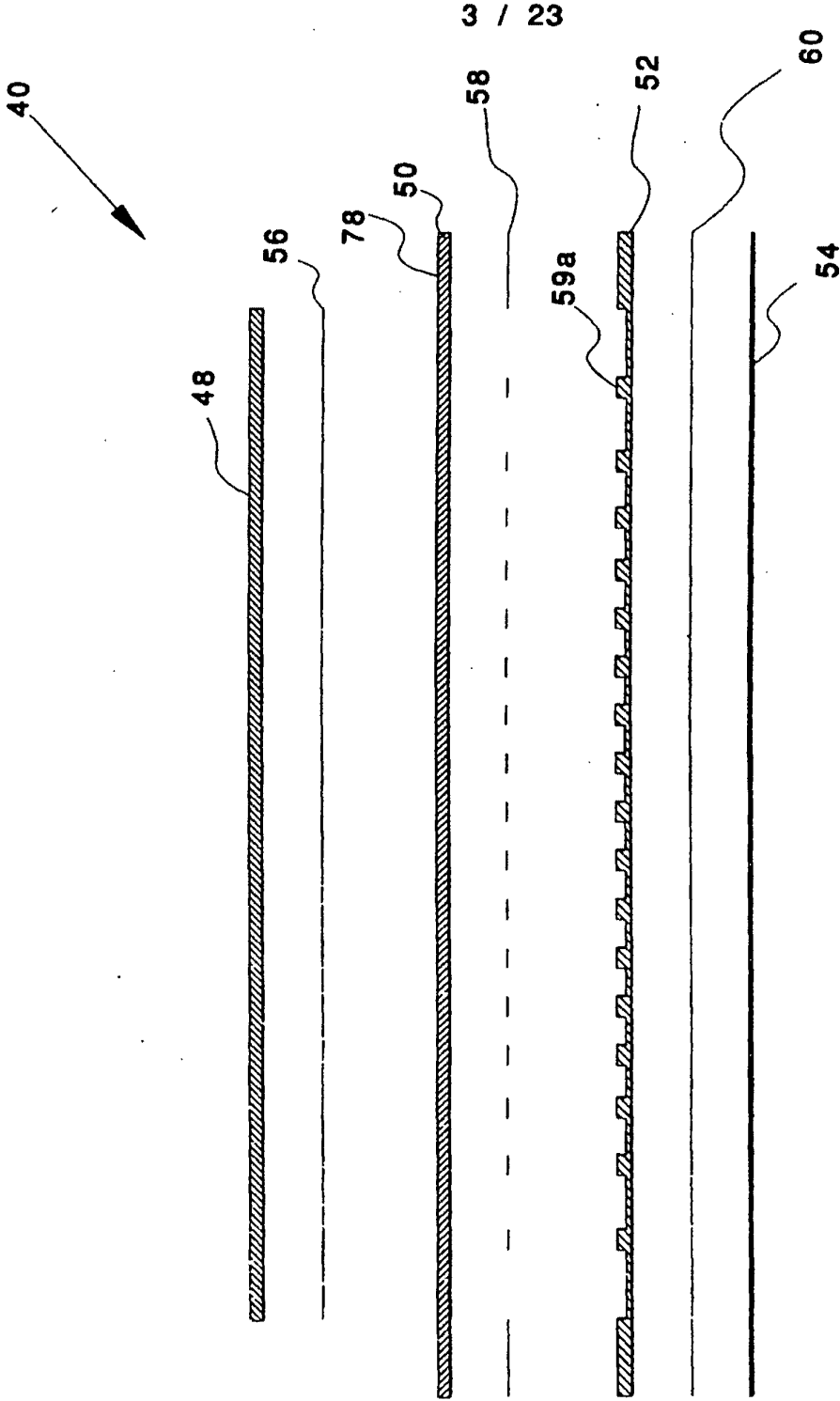


Fig. 3

**SUBSTITUTE SHEET (RULE 26)**



3 / 23

Fig. 4

**SUBSTITUTE SHEET (RULE 26)**

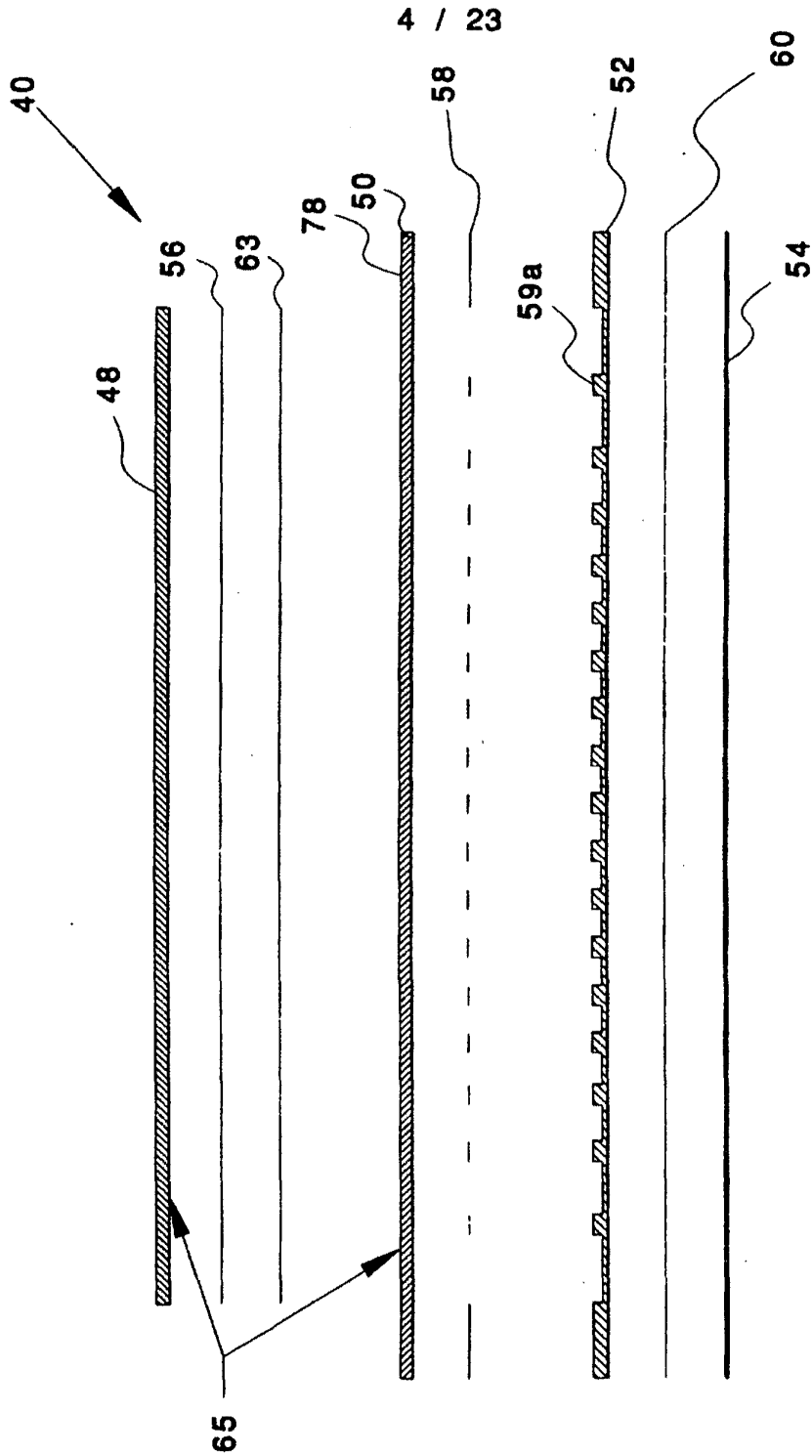


Fig. 5

**SUBSTITUTE SHEET (RULE 26)**

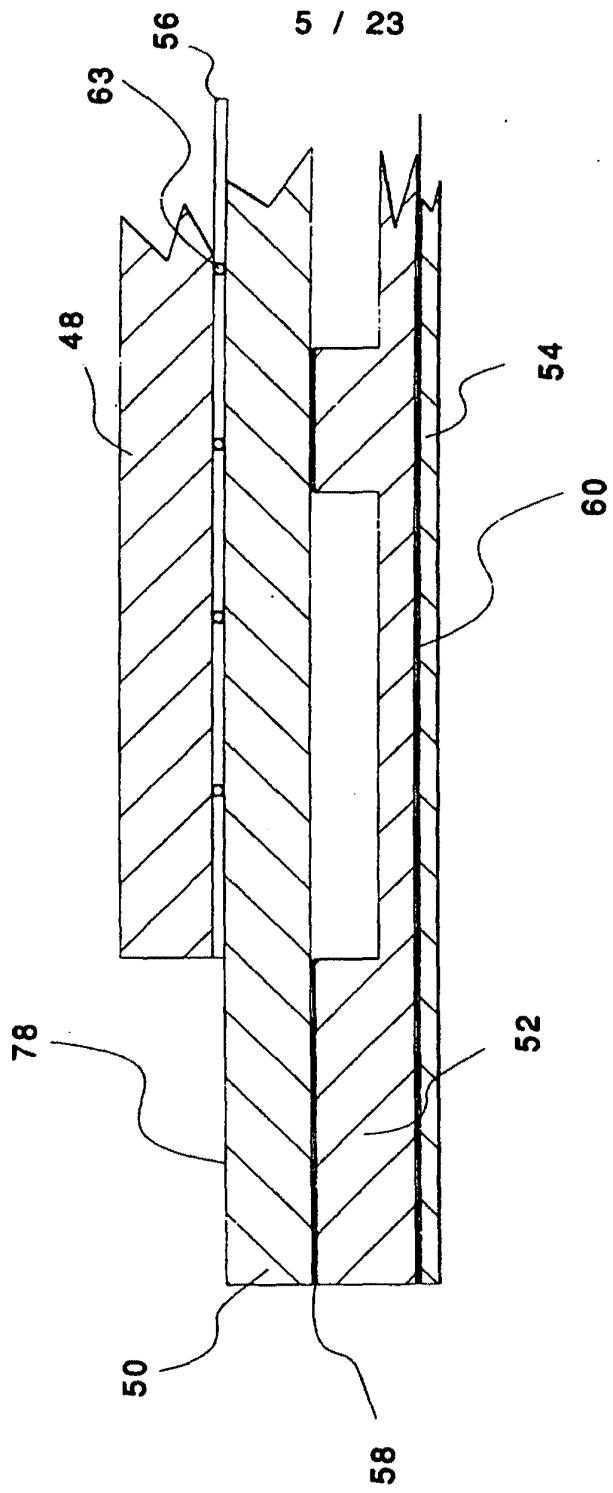


Fig. 6

**SUBSTITUTE SHEET (RULE 26)**

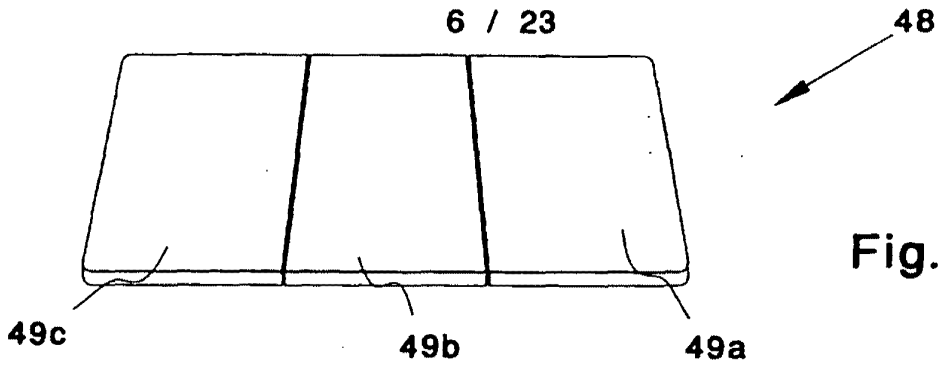


Fig. 7

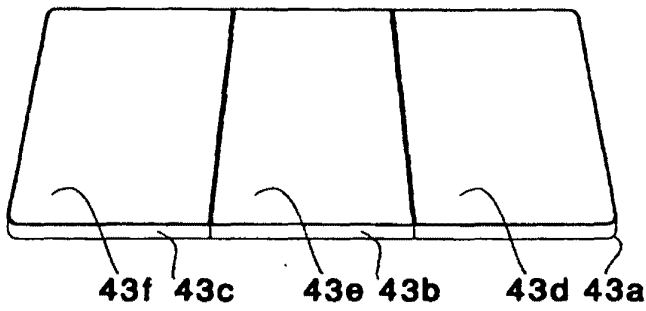


Fig. 8

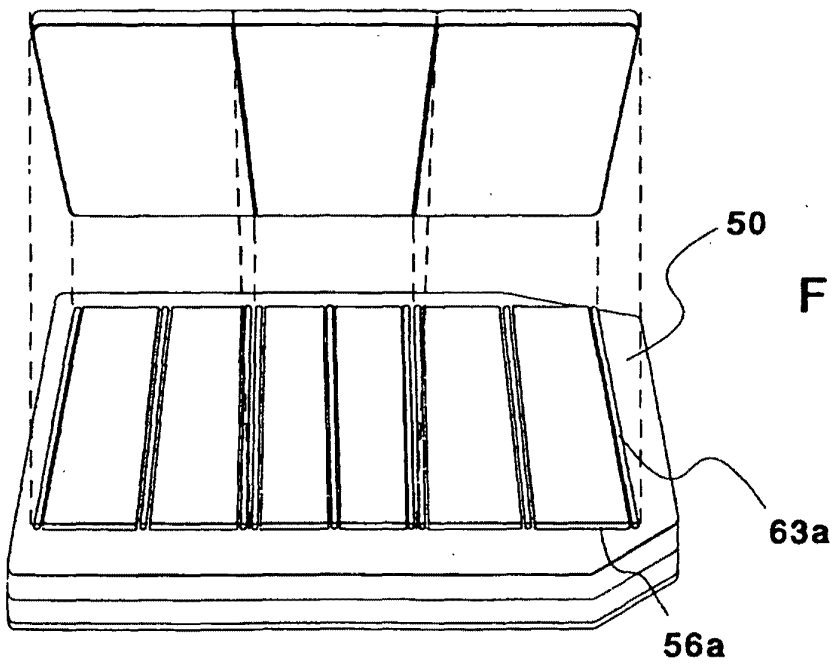


Fig. 9

**SUBSTITUTE SHEET (RULE 26)**



7 / 23

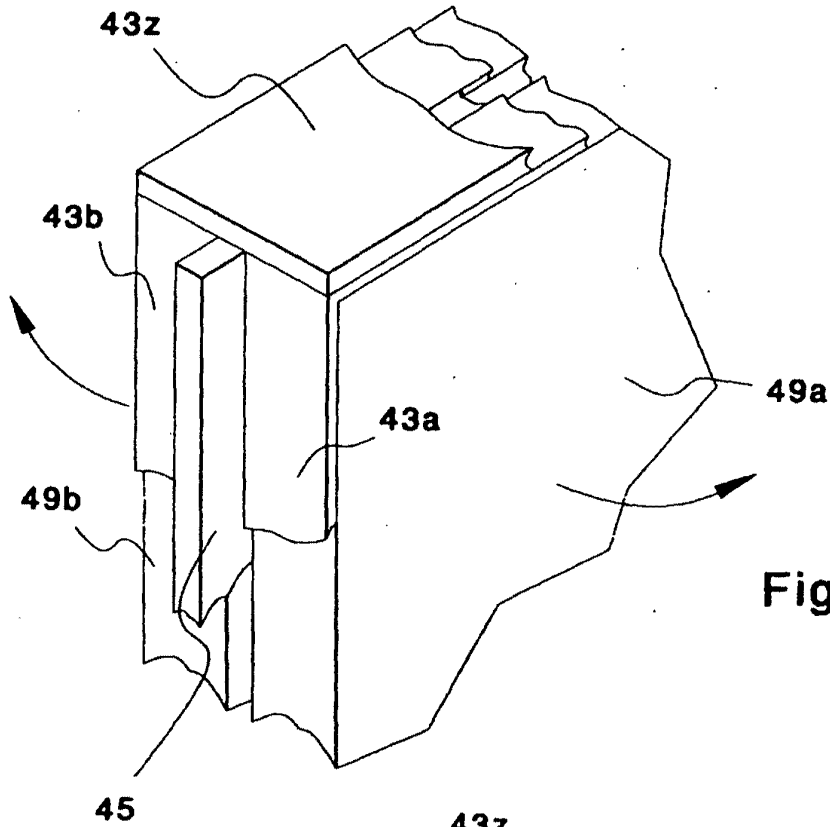


Fig. 8A

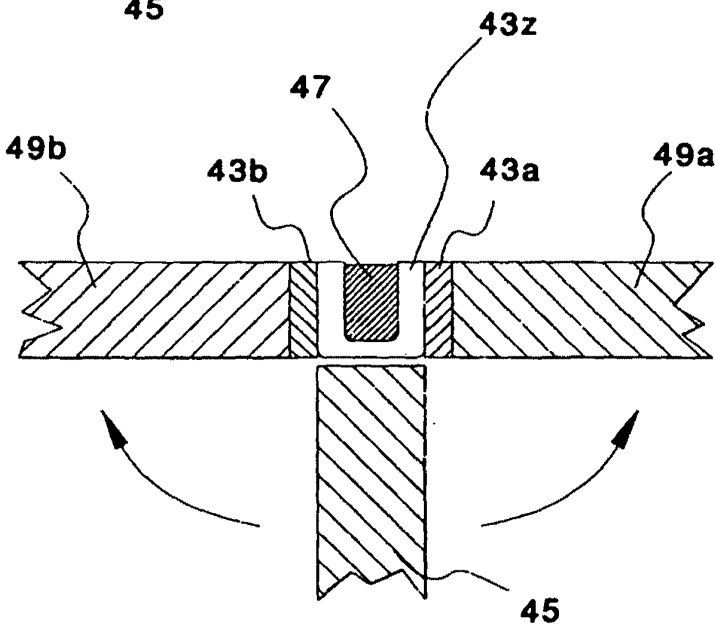


Fig. 8B

**SUBSTITUTE SHEET (RULE 26)**

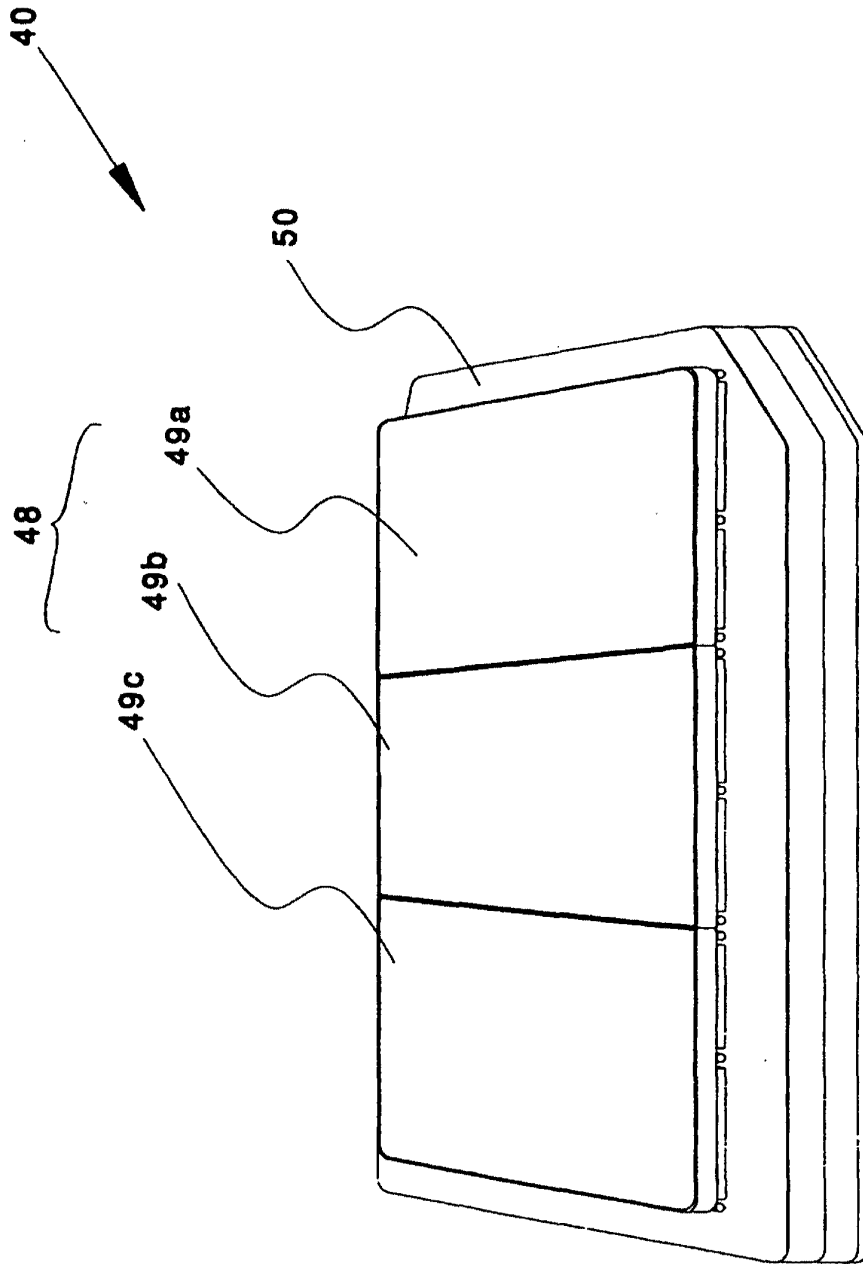


Fig. 10

**SUBSTITUTE SHEET (RULE 26)**

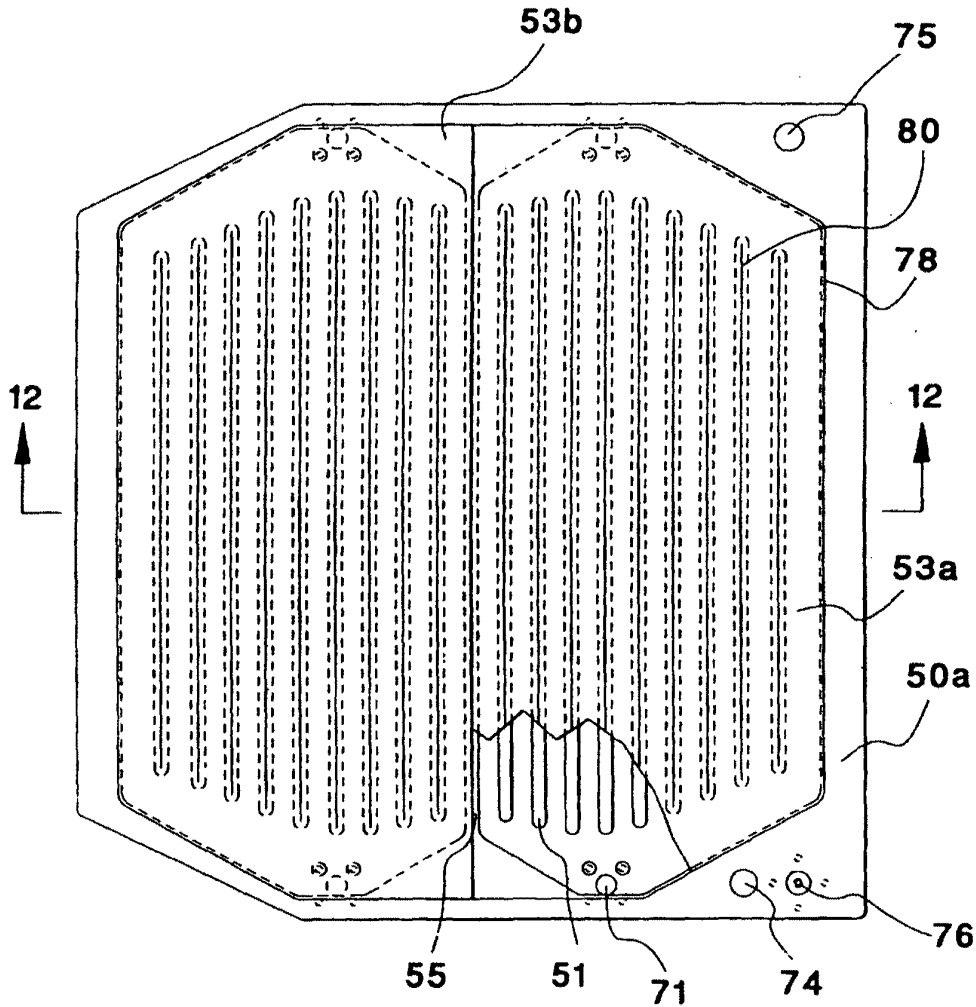


Fig. 11

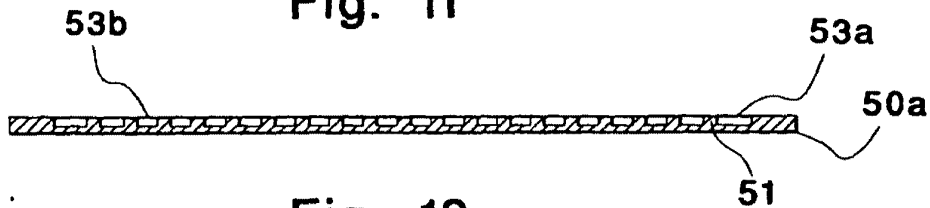


Fig. 12

**SUBSTITUTE SHEET (RULE 26)**

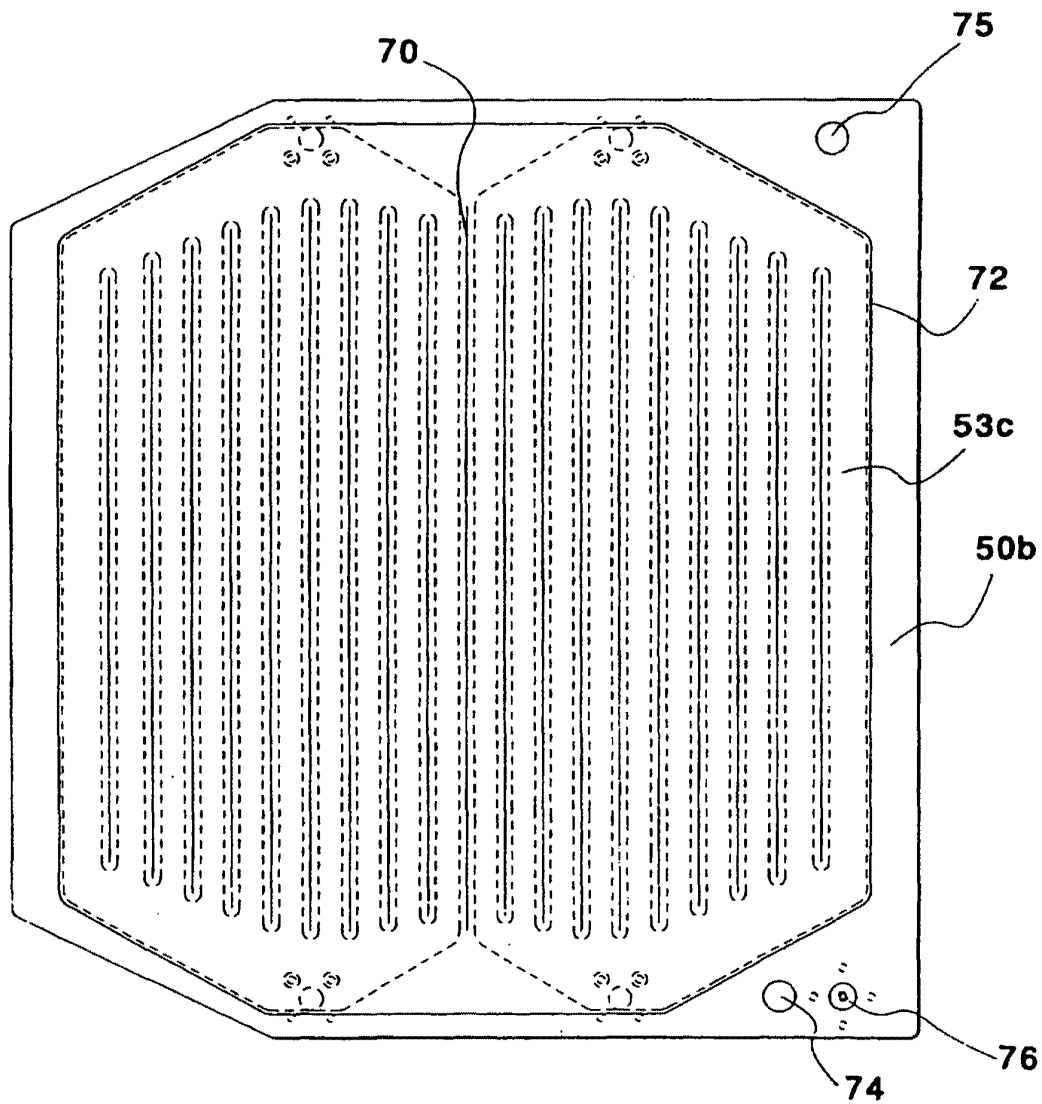


Fig. 13

**SUBSTITUTE SHEET (RULE 26)**

11 / 23

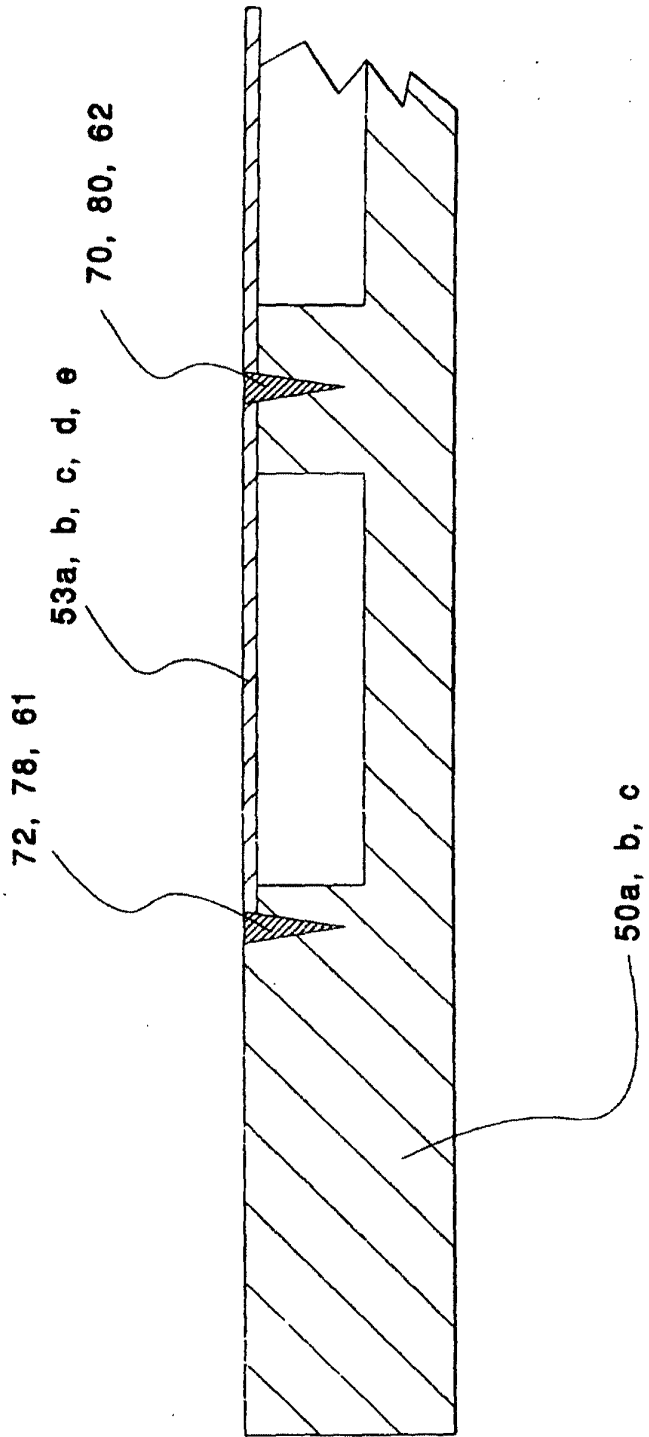


Fig. 14

**SUBSTITUTE SHEET (RULE 26)**

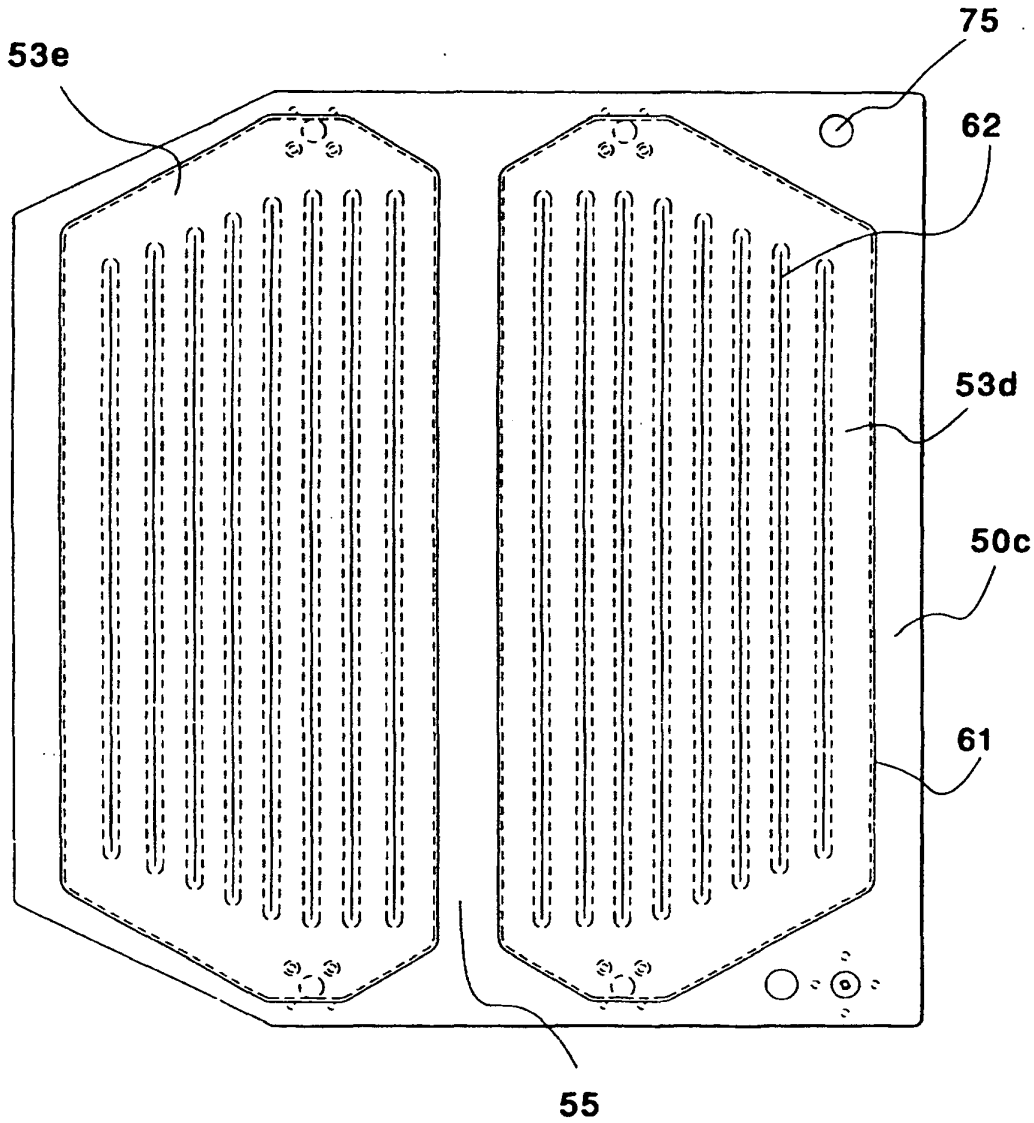


Fig. 15

**SUBSTITUTE SHEET (RULE 26)**

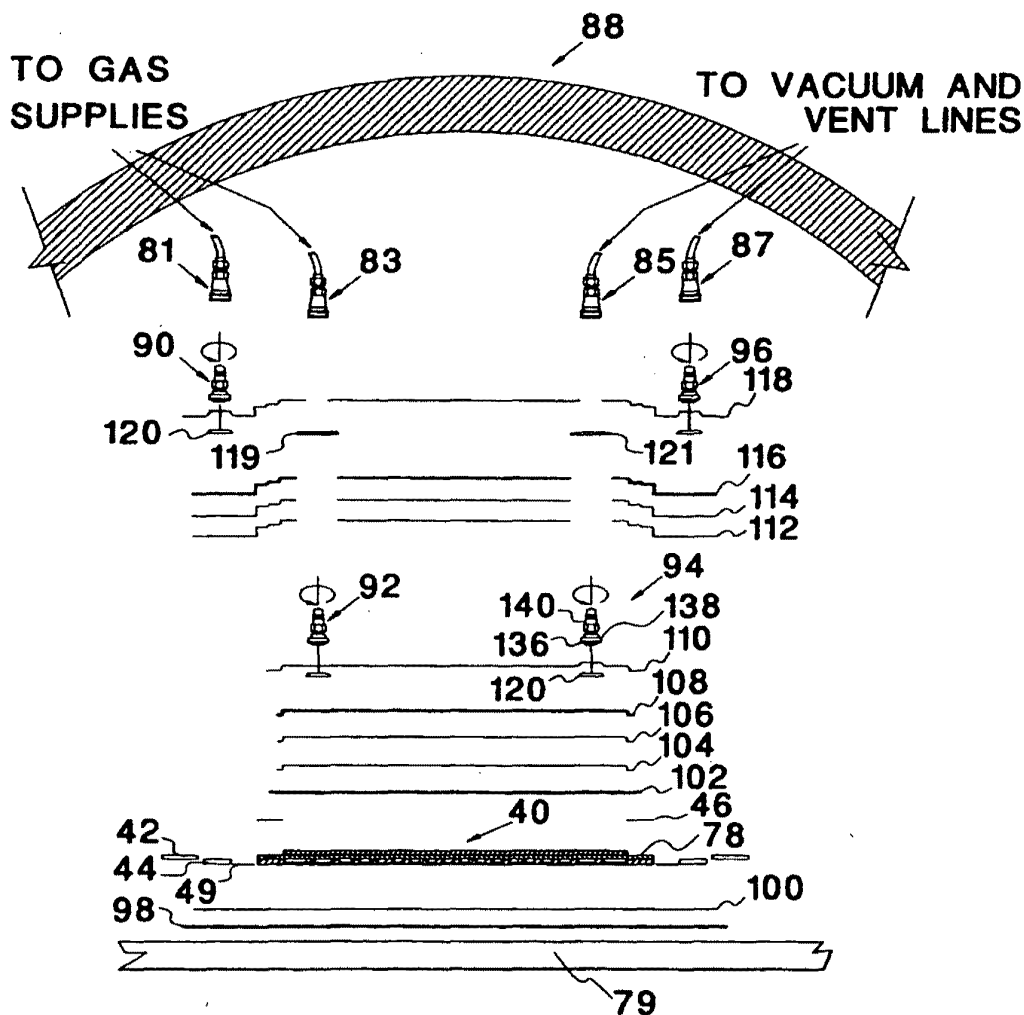


Fig. 16

SUBSTITUTE SHEET (RULE 26)

14 / 23

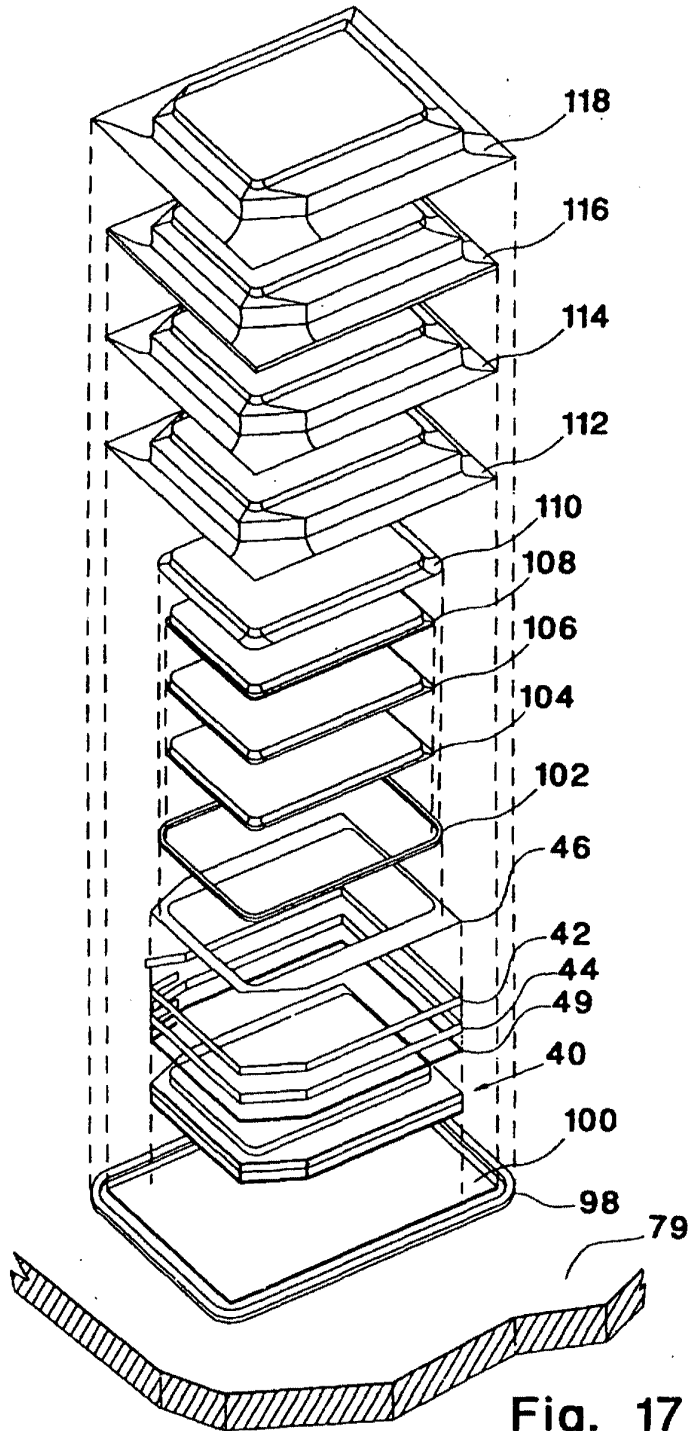


Fig. 17

**SUBSTITUTE SHEET (RULE 26)**



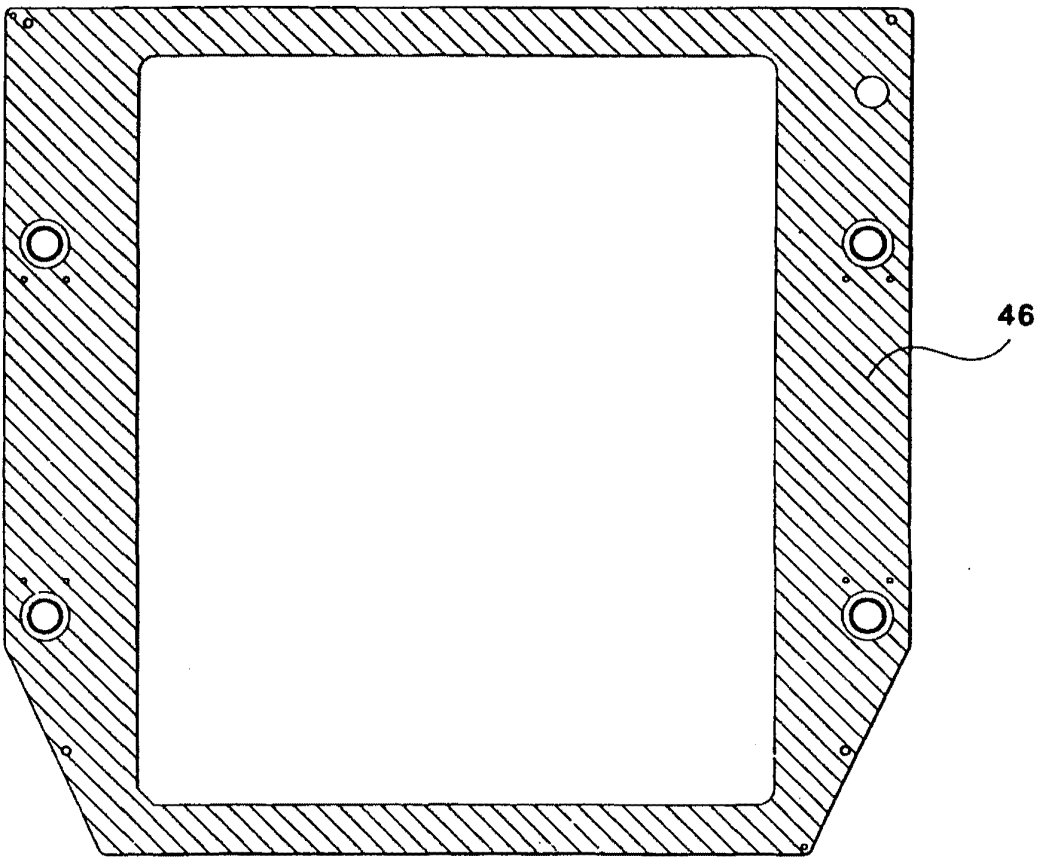


Fig. 18

SUBSTITUTE SHEET (RULE 26)

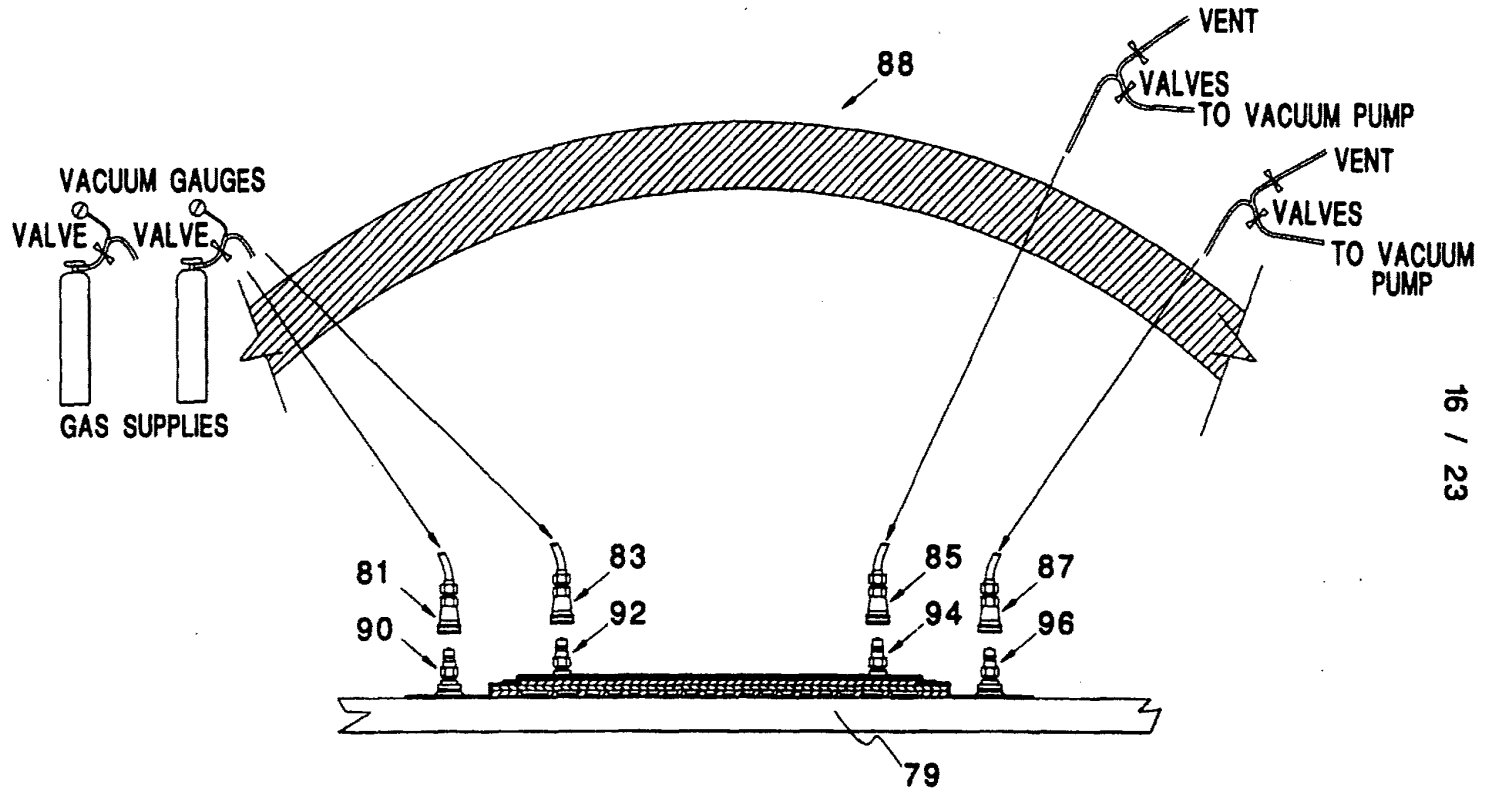


Fig. 19

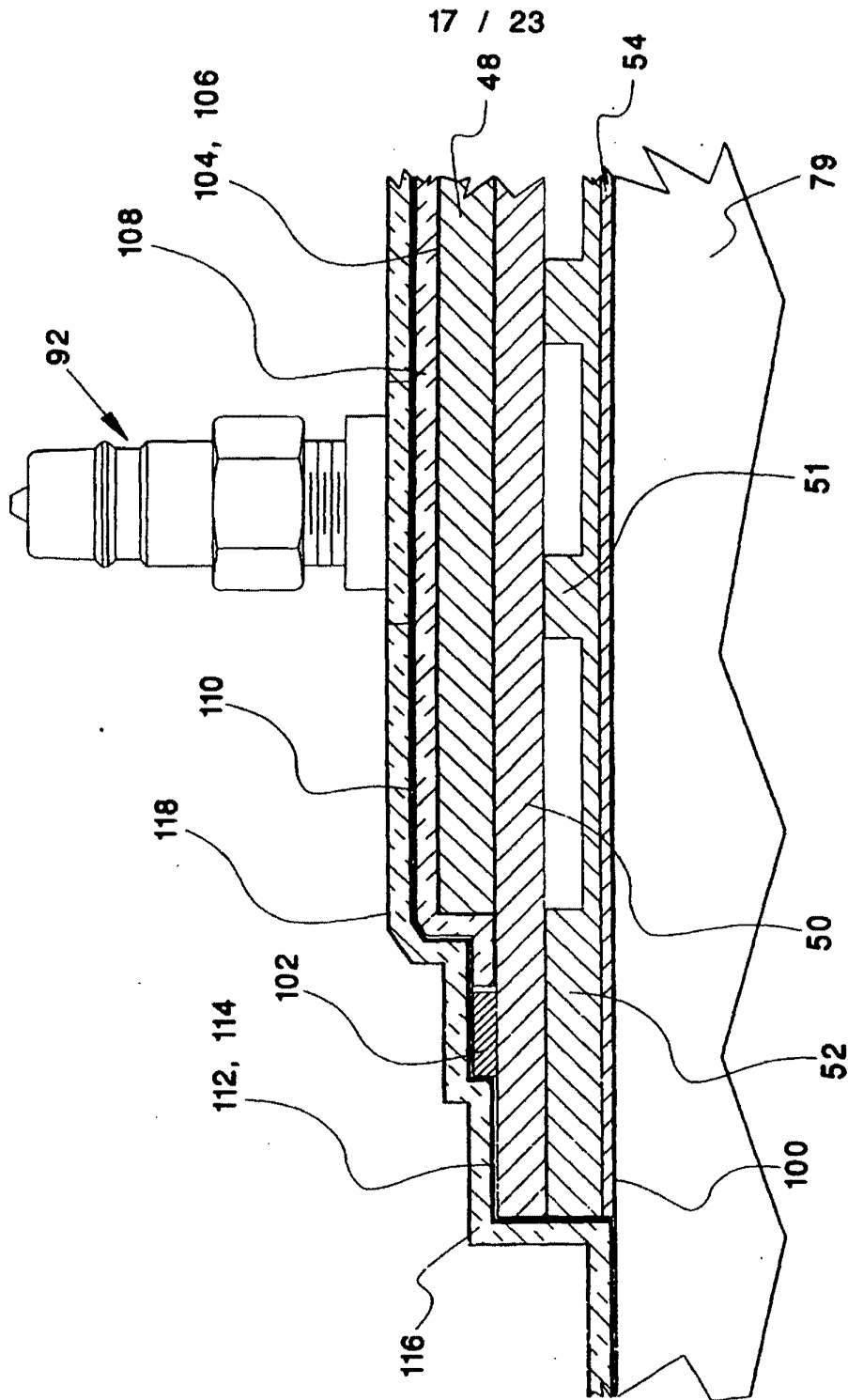


Fig. 20

SUBSTITUTE SHEET (RULE 26)

Fig. 22

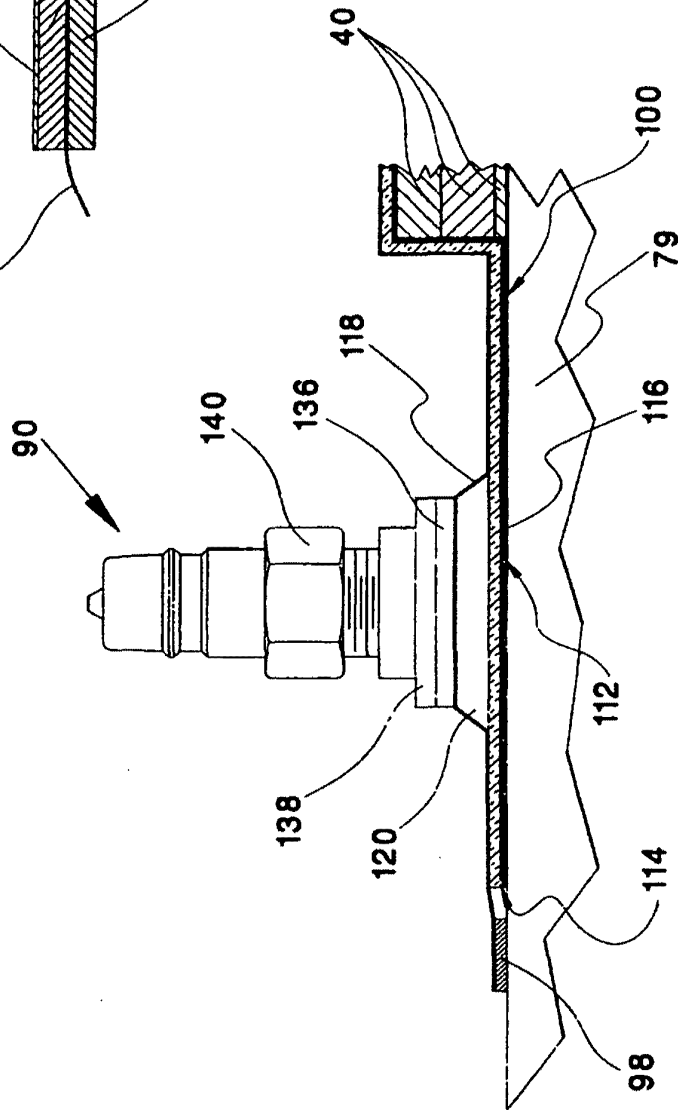
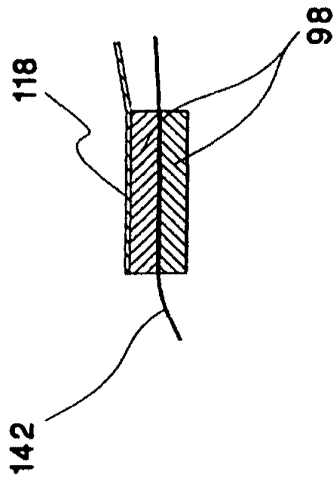


Fig. 21

SUBSTITUTE SHEET (RULE 26)

19 / 23

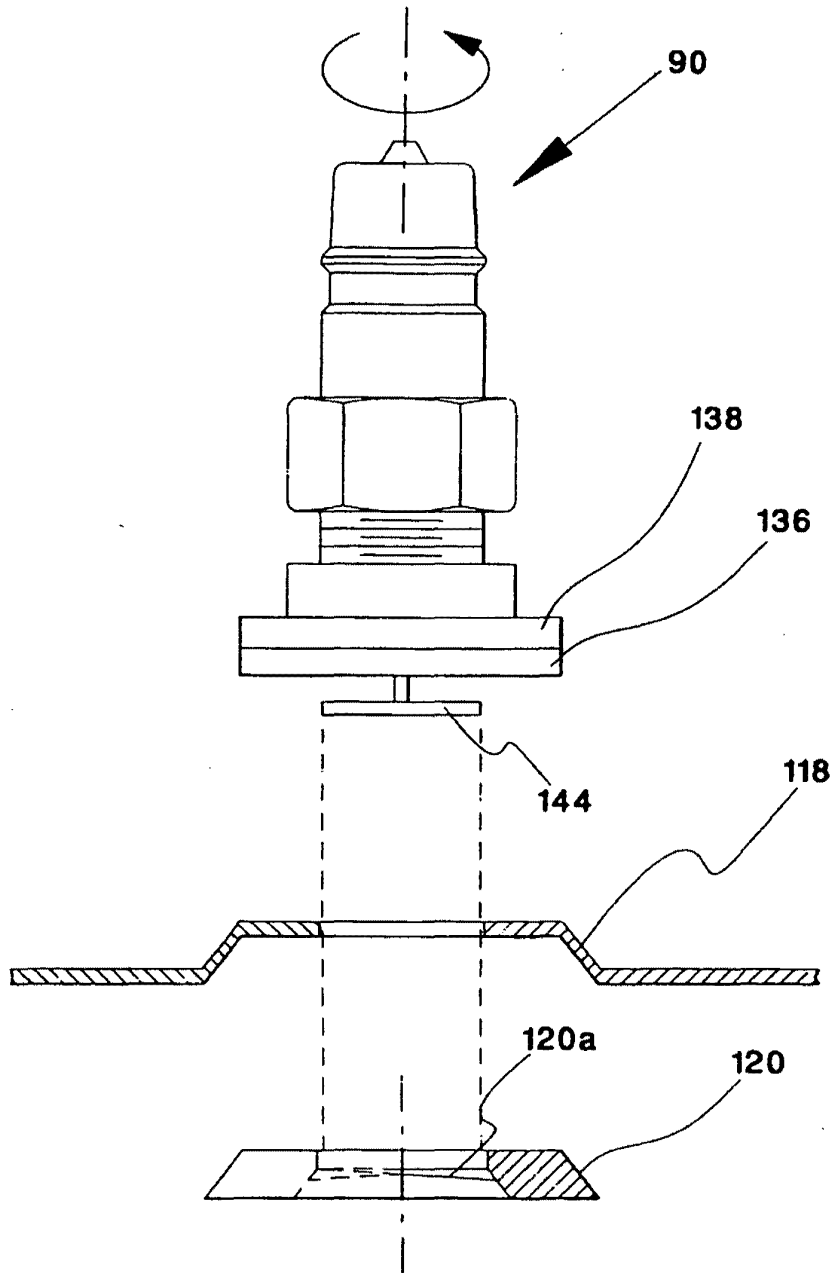


Fig. 23

SUBSTITUTE SHEET (RULE 26)

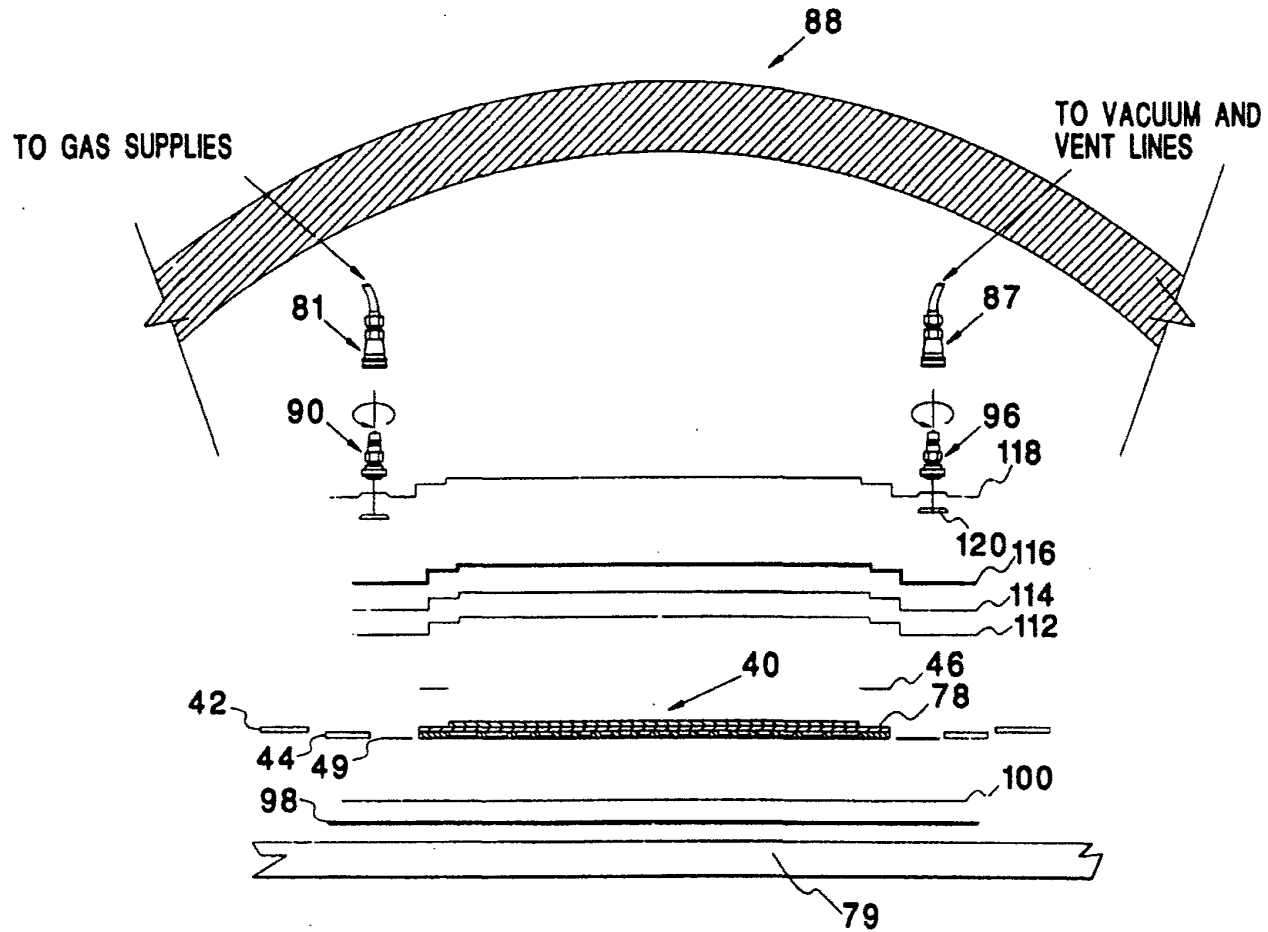


Fig. 24

21 / 23

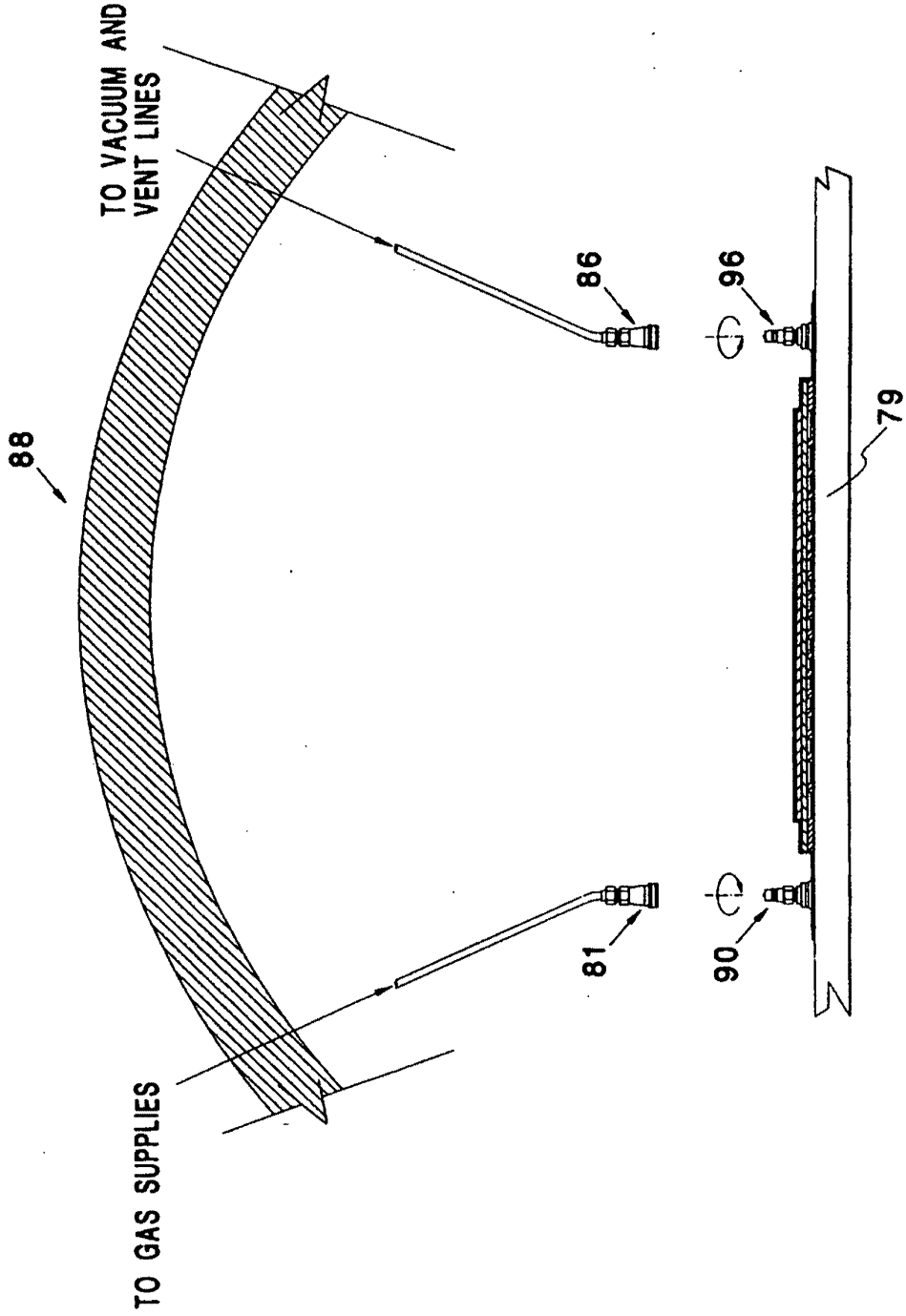


Fig. 25

SUBSTITUTE SHEET (RULE 26)

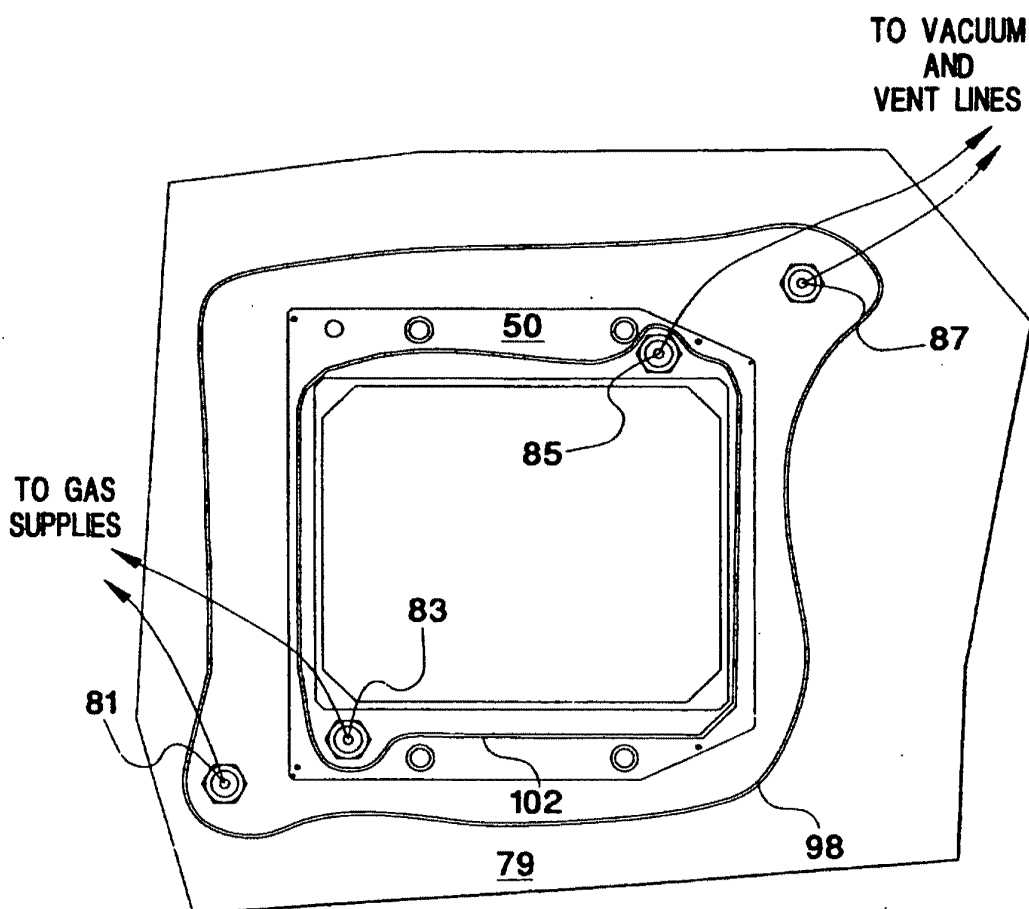


Fig. 26

SUBSTITUTE SHEET (RULE 26)



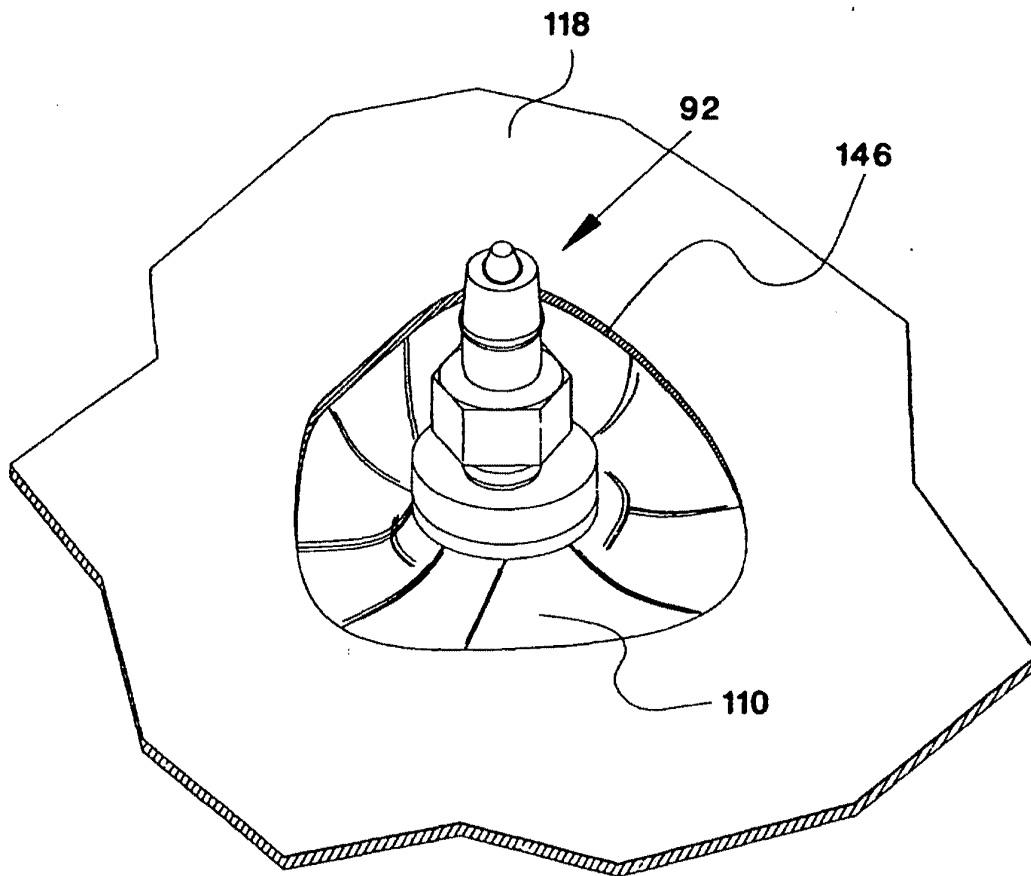


Fig. 27

SUBSTITUTE SHEET (RULE 26)

**INTERNATIONAL SEARCH REPORT**

International Application No  
**PCT/US 95/01089**

<b>A. CLASSIFICATION OF SUBJECT MATTER</b> IPC 6 C23C14/34 H01J37/34		
According to International Patent Classification (IPC) or to both national classification and IPC		
<b>B. FIELDS SEARCHED</b> Minimum documentation searched (classification system followed by classification symbols) IPC 6 C23C		
Documentation searched other than minimum documentation to the extent that such documents are included in the fields searched		
Electronic data base consulted during the international search (name of data base and, where practical, search terms used)		
<b>C. DOCUMENTS CONSIDERED TO BE RELEVANT</b>		
Category*	Citation of document, with indication, where appropriate, of the relevant passages	Relevant to claim No.
A	PATENT ABSTRACTS OF JAPAN vol. 013 no. 384 (C-629), 24 August 1989 & JP,A,01 132758 (HITACHI METALS LTD) 25 May 1989, see abstract	1-27
A	PATENT ABSTRACTS OF JAPAN vol. 013 no. 084 (C-572), 27 February 1989 & JP,A,63 270459 (MATSUSHITA ELECTRIC IND CO LTD) 8 November 1988, see abstract	1-27
	-/--	
<input checked="" type="checkbox"/> Further documents are listed in the continuation of box C. <input checked="" type="checkbox"/> Patent family members are listed in annex.		
* Special categories of cited documents :		
"A" document defining the general state of the art which is not considered to be of particular relevance "E" earlier document but published on or after the international filing date "L" document which may throw doubts on priority claim(s) or which is cited to establish the publication date of another citation or other special reason (as specified) "O" document referring to an oral disclosure, use, exhibition or other means "P" document published prior to the international filing date but later than the priority date claimed		
"T" later document published after the international filing date or priority date and not in conflict with the application but cited to understand the principle or theory underlying the invention "X" document of particular relevance; the claimed invention cannot be considered novel or cannot be considered to involve an inventive step when the document is taken alone "Y" document of particular relevance; the claimed invention cannot be considered to involve an inventive step when the document is combined with one or more other such documents, such combination being obvious to a person skilled in the art. "A" document member of the same patent family		
Date of the actual completion of the international search  <b>2 October 1995</b>		Date of mailing of the international search report  <b>24. 10 95</b>
Name and mailing address of the ISA European Patent Office, P.B. 581 & Patentaan 2 NL - 2280 HV Rijswijk Tel. (+ 31-70) 340-2040, Tx. 31 651 epo nl, Fax (+ 31-70) 340-3016		Authorized officer  <b>Ekhult, H</b>

Form PCT/ISA/210 (second sheet) (July 1992)

**INTERNATIONAL SEARCH REPORT**

International Application No  
**PCT/US 95/01089**

C.(Continuation) DOCUMENTS CONSIDERED TO BE RELEVANT		
Category	Citation of document, with indication, where appropriate, of the relevant passages	Relevant to claim No.
A	<p>REVIEW OF SCIENTIFIC INSTRUMENTS, APRIL 1973, USA, vol. 44, no. 4, ISSN 0034-6748, pages 522-523, TERHUNE C 'Target bonding (for sputtering)' see page 523, right column, line 4 - line 19</p> <p align="center">---</p>	1-27
A	<p>PATENT ABSTRACTS OF JAPAN vol. 015 no. 357 (C-0866) ,10 September 1991 &amp; JP,A,03 140464 (KOBELITE LTD) 14 June 1991, see abstract</p> <p align="center">---</p>	1-27
A	<p>GB,A,2 255 105 (ION COAT LIMITED) 28 October 1992 see page 7, line 16 - line 22</p> <p align="center">-----</p>	1-27

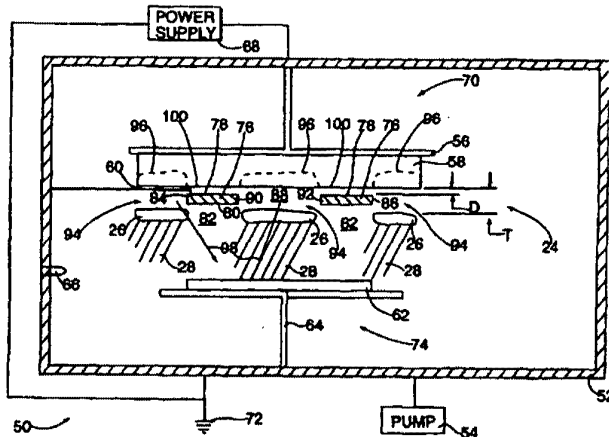
1



INTERNATIONAL APPLICATION PUBLISHED UNDER THE PATENT COOPERATION TREATY (PCT)

<p>(51) International Patent Classification <sup>6</sup> : <b>C23C 14/40</b></p>	<p><b>A1</b></p>	<p>(11) International Publication Number: <b>WO 97/35044</b> (43) International Publication Date: 25 September 1997 (25.09.97)</p>
<p>(21) International Application Number: PCT/US97/03047 (22) International Filing Date: 4 March 1997 (04.03.97) (30) Priority Data: 08/620,650 22 March 1996 (22.03.96) US (71) Applicant: MATERIALS RESEARCH CORPORATION [US/US]; 560 Route 303, Orangeburg, NY 10962 (US). (72) Inventor: HURWITT, Steven; 159 Pascack Road, Park Ridge, NJ 07656 (US). (74) Agents: MILLER, Jerry, A. et al.; 1 Sony Drive, MD #T1-1, Park Ridge, NJ 07656 (US).</p>	<p>(81) Designated States: AL, AM, AT, AU, AZ, BA, BB, BG, BR, BY, CA, CH, CN, CU, CZ, DE, DK, EE, ES, FI, GB, GE, GH, HU, IL, IS, JP, KE, KG, KP, KR, KZ, LC, LK, LR, LS, LT, LU, LV, MD, MG, MK, MN, MW, MX, NO, NZ, PL, PT, RO, RU, SD, SE, SG, SI, SK, TJ, TM, TR, TT, UA, UG, UZ, VN, YU, ARIPO patent (GH, KE, LS, MW, SD, SZ, UG), Eurasian patent (AM, AZ, BY, KG, KZ, MD, RU, TJ, TM), European patent (AT, BE, CH, DE, DK, ES, FI, FR, GB, GR, IE, IT, LU, MC, NL, PT, SE), OAPI patent (BF, BJ, CF, CG, CI, CM, GA, GN, ML, MR, NE, SN, TD, TG).</p> <p>Published With international search report.</p>	

(54) Title: METHOD AND APPARATUS FOR RF DIODE SPUTTERING



(57) Abstract

A sputtering system (50) includes an evacuable chamber (52) having a target (58) which includes a sputtering surface (60). The target (58) is biased to form a cathode element (70) which causes the emission of electrons. The system (50) further includes an anode element (74) which includes the substrate (62). In use, a sputtering gas is ionized in response to the electrons to form a plasma. The plasma includes a cathode dark space (24) having a first thickness (T) wherein ionization does not occur. A plate element (76) having a bottom surface (80) is positioned a first distance (D) from the sputtering surface (60). Electrons emitted from the target (58) are absorbed by the plate element (76) to inhibit plasma formation in a first area (82) adjacent the bottom surface (60) such that target material (58) is not eroded opposite the first area (82). Further, plasma is formed in a second area (94) adjacent an edge (84, 86, 90, 92) to cause target material (58) to be eroded from the second area (94).

**FOR THE PURPOSES OF INFORMATION ONLY**

Codes used to identify States party to the PCT on the front pages of pamphlets publishing international applications under the PCT.

AL	Albania	ES	Spain	LS	Lesotho	SI	Slovenia
AM	Armenia	FI	Finland	LT	Lithuania	SK	Slovakia
AT	Austria	FR	France	LU	Luxembourg	SN	Senegal
AU	Australia	GA	Gabon	LV	Latvia	SZ	Swaziland
AZ	Azerbaijan	GB	United Kingdom	MC	Monaco	TD	Chad
BA	Bosnia and Herzegovina	GE	Georgia	MD	Republic of Moldova	TG	Togo
BB	Barbados	GH	Ghana	MG	Madagascar	TJ	Tajikistan
BE	Belgium	GN	Guinea	MK	The former Yugoslav Republic of Macedonia	TM	Turkmenistan
BF	Burkina Faso	GR	Greece	ML	Mali	TR	Turkey
BG	Bulgaria	HU	Hungary	MN	Mongolia	TT	Trinidad and Tobago
BJ	Benin	IE	Ireland	MR	Mauritania	UA	Ukraine
BR	Brazil	IL	Israel	MW	Malawi	UG	Uganda
BY	Belarus	IS	Iceland	MX	Mexico	US	United States of America
CA	Canada	IT	Italy	NE	Niger	UZ	Uzbekistan
CF	Central African Republic	JP	Japan	NL	Netherlands	VN	Viet Nam
CG	Congo	KE	Kenya	NO	Norway	YU	Yugoslavia
CH	Switzerland	KG	Kyrgyzstan	NZ	New Zealand	ZW	Zimbabwe
CI	Côte d'Ivoire	KP	Democratic People's Republic of Korea	PL	Poland		
CM	Cameroon	KR	Republic of Korea	PT	Portugal		
CN	China	KZ	Kazakstan	RO	Romania		
CU	Cuba	LC	Saint Lucia	RU	Russian Federation		
CZ	Czech Republic	LJ	Liechtenstein	SD	Sudan		
DE	Germany	LK	Sri Lanka	SE	Sweden		
DK	Denmark	LR	Liberia	SG	Singapore		
EE	Estonia						

## METHOD AND APPARATUS FOR RF DIODE SPUTTERING

### FIELD OF THE INVENTION

5 This invention relates to RF diode sputtering, and more particularly, to a plate positioned within a cathode dark space which serves to selectively inhibit plasma formation in order to be able to selectively erode areas of a sputtering surface to provide a desired non-uniform erosion pattern for improving thickness uniformity for a film formed on a substrate.

### BACKGROUND OF THE INVENTION

10 An integrated circuit (IC) is manufactured by a process which utilizes planar technology. Generally, this process includes subjecting a substrate, such as a silicon wafer or a ceramic plate, to a sputtering process in which a thin layer or film of material is deposited on the substrate. A common type of sputtering is known as magnetron sputtering. In this type of sputtering, a sputter deposition system is used which includes a chamber having a sputtering target. The target is  
15 fabricated from a desired source material and includes a sputtering surface from which material is removed for forming the film. In operation, a substrate which is to be sputtered is positioned within the chamber opposite the sputtering surface. A process gas, such as argon, is introduced into the chamber between the sputtering surface and the substrate. The target is then negatively energized so as to cause electrons to be emitted from the target. The electrons strike and ionize  
20 the gas particles to cause the formation of a plasma having positively charged argon ions. The ions then bombard the sputtering surface, which causes the removal of target material. The removed target material is then ultimately deposited onto the substrate to form the film.

25 A magnetic field for confining and shaping the plasma into a desired configuration is positioned near the sputtering surface. In particular, the plasma is shaped such that a desired non-uniform pattern of erosion is formed on the sputtering surface. This serves to ensure that all areas of the substrate receive substantially equal amounts of sputtered material, thus enabling a substantially uniform film thickness to be formed on the substrate.

In an alternative form of sputtering, which is known as radio frequency (RF) diode sputtering, a magnetic field is not utilized to confine or shape the plasma. This type of sputtering

is frequently used for the sputtering of electrically insulating target materials, and for sputtering targets of magnetic material. In addition, RF diode sputtering is also used where the presence of magnetic fields generated by the sputtering cathode may undesirably affect properties of the deposited film. However, since a magnetic field is not used to confine and shape the plasma in RF diode sputtering, the erosion pattern of the sputtering surface cannot be controlled as desired. As a result, an undesirable uniform erosion pattern forms on the sputtering surface which results in the formation of a film thickness that is not uniform. Further, reduced deposition occurs near the substrate edge due to the shape of the plasma, which also undesirably affects film thickness uniformity.

Referring now to FIGURE 1, an illustrative depiction of a plasma 10 is shown located between a target 12 having an initial sputtering surface 14 and a substrate 18 which is supported by support 16. The plasma 10 includes several different functional zones which are formed during the sputtering process. In use, the target 12 is negatively energized and the support 16 is grounded to form a cathode element 20 and an anode element 22, respectively. This causes electrons to be emitted from the target 12 which travel through a cathode dark space 24 and then collide with gas molecules to cause the formation of ions in a negative glow area 26 and a positive column 28. In the cathode dark space 24, ionization does not occur since the emitted electrons typically do not possess sufficient energy. Further, the cathode dark space 24 has a thickness  $T$  which depends primarily on the voltage applied to the target 12 and the type and pressure of the sputtering gas utilized. The ions are then accelerated towards cathode element 20 by a high voltage gradient across the cathode dark space 24.

A device known as a dark space shield 30 is located adjacent to a rear surface 32 of the target 12. The shield 30 is spaced apart from the rear surface 32 by a distance  $X$  which is less than thickness  $T$ . As such, the shield 30 is located in a region where ionization does not occur. The shield 30 is connected to ground 34 and serves to absorb electrons which are emitted, thus inhibiting the formation of plasma adjacent the rear surface 32. The shield 30 is utilized in configurations wherein sputtering on the rear surface 32 is not desired such as when a structural backing plate is used to support the cathode element 20. For plasmas which are not magnetically confined, thickness  $T$  is typically between approximately 0.25 to 0.75 inches under commonly used sputtering conditions.

One method of improving film thickness uniformity in RF diode sputtering is to increase the size of the target 12 relative to the substrate 18. This has been found to reduce the effect of reduced deposition near the substrate edge. However, a disadvantage of this method is that larger and more costly targets are needed. This results in the need for correspondingly larger processing chambers to hold the targets and larger power supplies to energize the targets, which also increases costs. Moreover, the use of larger targets results in reduced utilization of target material.

Another method for improving film thickness uniformity includes the positioning of an object, such as an aperture plate, between the target and substrate. The aperture plate serves to intercept a percentage of sputtered material to prevent its deposition on the substrate. This method is described in U. S. Patent No. 5,415,753, which issued to Hurwitz, et al. and is assigned to Materials Research Corporation, an assignee herein. Referring to FIGURE 2, an illustrative cross sectional view of a portion of an aperture plate 36 having an aperture 38 in accordance with U.S. Patent No. 5,415,753 is shown. The aperture plate 36 is located between the target 12 and the substrate 18 which is to be sputtered. In RF diode sputtering, wherein a magnetic field is not used to control the plasma, the initial sputtering surface 14 is eroded in an undesirable uniform pattern to form a new sputtering surface 40 (shown as dashed lines) which is generally flat and parallel to the initial sputtering surface 14. The design of the aperture plate 36 and its spacing from target 12 and substrate 18 is calculated so as to intercept controlled amounts of material emitted from target 12. In particular, a portion of sputtered material (illustrated by arrow 42 which depicts a flight path of a first particle) emitted from the target 12 passes through or around the aperture plate 36 and is deposited on substrate 18. Another portion of sputtered material (illustrated by arrow 44 which depicts a flight path of a second particle) is intercepted by the aperture plate 36 and forms a deposit 46 on the aperture plate 36. As such, this technique improves thickness uniformity by intercepting material emitted from target 12 and not by controlling the shape of the plasma.

However, this technique has disadvantages. One disadvantage is that extended spacing is needed between target 12 and substrate 18 to permit proper placing of target 12 to avoid a shadow of the aperture plate 36 from forming in the deposited film. Another disadvantage is that



as more material is sputtered, the deposit 46 increases in size and forms flakes or microscopic particles which fall on or become imbedded in the film that is formed on the substrate.

## SUMMARY OF THE INVENTION

5 It is an object of the present invention to provide a sputtering system for improving thickness uniformity of a film sputtered on a substrate.

It is a further object of the present invention to selectively inhibit the formation of plasma by absorbing electrons emitted from a target in order to provide a desired non-uniform erosion pattern suitable for improving film thickness uniformity.

10 The present invention relates to a sputtering system for depositing a thin film on a substrate. In particular, the system includes an evacuable chamber having a target. The target includes a sputtering surface which is biased to form a cathode element which emits electrons. The system further includes an anode element which includes the substrate. The substrate is positioned opposite the cathode element in the chamber. In use, a sputtering gas is ionized in response to the electrons to form a plasma for eroding target material from the sputtering surface  
15 which is then deposited on the substrate to form the film. In addition, the plasma includes a cathode dark space having a first thickness wherein ionization does not occur.

20 A plate element having a bottom surface and at least one edge is positioned a first distance, which is less than the first thickness, from the sputtering surface. Electrons emitted from the target are absorbed by the plate element so as to selectively inhibit plasma formation in a first area adjacent the bottom surface such that target material is not eroded from a predetermined first portion of the sputtering surface opposite the first area. Further, plasma is formed in a second area adjacent the edge to cause target material to be eroded from a predetermined second portion of the sputtering surface opposite the second area. This forms a desired non-uniform erosion pattern on the sputtering surface for improving thickness uniformity of the film.

## 25 BRIEF DESCRIPTION OF THE FIGURES

FIGURE 1 depicts a conventional plasma formed during a sputtering process.

FIGURE 2 is a cross section view of a portion of an aperture plate for intercepting material sputtered from a sputtering surface.

FIGURE 3 depicts a sputtering system having a plate element positioned within a cathode dark space in accordance with the present invention.

## 5 DETAILED DESCRIPTION OF THE PREFERRED EMBODIMENTS

While this invention is susceptible of embodiment in many different forms, there is shown in the drawings and will herein be described in detail specific embodiments, with the understanding that the present disclosure is to be considered as an example of the principles of the invention and intended to limit the invention to the specific embodiments shown and described. In the  
10 description below, like reference numerals are used to describe the same, similar or corresponding parts in FIGURES 1-3.

Referring to FIGURE 3, a sputtering system 50 in accordance with the present invention is shown. The system 50, which may be an RF diode sputtering system, includes a chamber 52 which is evacuated by a vacuum pump 54 to a vacuum level suitable for sputtering. The chamber  
15 52 includes a target mounting element 56 for holding a target 58. The target 58 includes a sputtering surface 60 from which target material is removed, or sputtered, which is ultimately deposited on a substrate 62 to form a thin film. The system 50 further includes a support 64 for holding the substrate 62 in a position generally opposite the sputtering surface 60. In use, a sputtering gas, such as argon, is introduced into the chamber 52 through a nozzle 66. The target  
20 58 is then negatively energized by a power supply 68 to cause an emission of electrons from the target 58, thus forming a cathode element 70. Further, the support 64 and substrate 62 are connected to ground 72, thus forming an anode element 74.

A plate element 76 (shown as a cross section) is positioned between the cathode 70 and anode 74 elements. The plate element 76 includes a top surface 78 which is spaced apart from  
25 the sputtering surface 60 by a distance D which is less than thickness T. This serves to locate the plate element 76 within the cathode dark space 24. The plate element 76 further includes a bottom surface 80 which faces the substrate 62. The plate element 76 is connected to ground and thus serves to attract and absorb electrons which are emitted from the target 58. In accordance

with the present invention, this inhibits the formation of plasma in first areas 82 adjacent the bottom surface 80. Alternatively, it is noted that the plate element 76 and/or the substrate 62 may be subjected to a desired voltage by an alternate power supply rather than being connected to ground.

5           The plate element 76 further includes left 84 and right 86 outer vertical edges and a hole 88 which defines left 90 and right 92 inner vertical edges. In use, normal plasma formation occurs in second areas 94 which are adjacent the vertical edges 84, 86, 90, 92 and wherein electrons are not absorbed by plate element 76. As a result, first portions 96 of the sputtering surface which are directly opposite the second areas 94 are eroded. Some of the material removed from  
10 portions 96 (illustrated by arrow 98 which depicts flight paths of removed material) is then ultimately deposited on the substrate to form the film.

          In accordance with the present invention, second portions 100 of the sputtering surface 60 which are opposite the first areas 82 do not erode due to the absence of plasma in these areas. This results in a desired non-uniform pattern of erosion on the sputtering surface 60 which  
15 provides a film on the substrate 62 having a substantially uniform thickness. Consequently, the present invention provides a uniform film thickness by selectively inhibiting the formation of plasma. In addition, since target material is not sputtered from second portions 100, the amount of target material that is accumulated on the top surface 78 is substantially reduced. Thus, contamination of the film due to the formation of flakes and particles on the top surface 78 is also  
20 substantially reduced.

          The shape and dimensions of plate element 76 are each chosen to provide a desired erosion shape on target 58 which will produce a desired film profile on substrate 62. Several factors affect the configuration of plate element 76 such as the size of the target 56 and the substrate 62 and the distance between the target 58 and substrate 62. For typical sputtering  
25 conditions, it has been found that acceptable results are obtained when dimension D is between approximately 0.05 inch to 1.0 inch, wherein 1/8 to 3/8 of an inch is preferred. It is further noted that plate element 76 may also be configured in various other shapes and sizes so as to provide a desired film profile on substrate 62. For example, plate element 76 may be configured to include more than one hole. Alternatively, plate element 76 may be a solid plate. In addition, a series  
30 of concentric rings may be used in place of plate element 76.

Thus it is apparent that in accordance with the present invention, an apparatus that fully satisfies the objectives, aims and advantages is set forth above. While the invention has been described in conjunction with specific embodiments, it is evident that many alternatives, modifications, permutations and variations will become apparent to those skilled in the art in light of the foregoing description. Accordingly, it is intended that the present invention embrace all such alternatives, modifications and variations are far within the scope of the appended claims.

**What Is Claimed Is:**

1. A sputtering system for depositing a thin film on a substrate, said system including an evacuable chamber which includes said substrate, comprising:

a target positioned within said chamber, said target including a sputtering surface;

biasing means for biasing said target to form a cathode element which emits electrons;

an anode element which includes said substrate, wherein said substrate is positioned opposite said cathode element in said chamber;

ionization means for ionizing a sputtering gas, in response to said electrons, to form a plasma for eroding target material from said sputtering surface which is then deposited on said substrate to form said film, said plasma including a cathode dark space having a first thickness wherein ionization does not occur; and

a plate element having a bottom surface and at least one edge, said plate element being spaced apart from said sputtering surface by a first distance which is less than said first thickness, wherein electrons emitted from said target are absorbed by said plate element to selectively inhibit plasma formation in a first area adjacent said bottom surface such that target material is not eroded from a predetermined first portion of said sputtering surface opposite said first area, and wherein plasma is formed in a second area adjacent said edge to cause target material to be eroded from a predetermined second portion of said sputtering surface opposite said second area, thereby forming a desired non-uniform erosion pattern on said sputtering surface for improving thickness uniformity of said film.

2. The system according to claim 1, wherein said plate includes at least one hole for forming associated inner edges.

3. The system according to claim 1, wherein said plate element includes at least two concentric rings.

4. The system according to claim 1, wherein said plate element is a solid plate.

5. The system according to claim 1, wherein said plate element is maintained at a potential which is positive relative to said target.
6. The system according to claim 1, wherein said plate element is grounded.
7. The system according to claim 1, wherein said first distance is between approximately 0.05 and 1.0 inches.
8. A method for sputtering a thin film on a substrate, comprising the steps of:
  - biasing a target having a sputtering surface to form a cathode element which emits electrons;
  - providing an anode element which includes said substrate, wherein said substrate is positioned opposite said cathode element;
  - forming a plasma, in response to said electrons, for eroding target material from said sputtering surface which is then deposited on said substrate to form said film, said plasma including a cathode dark space having a first thickness;
  - positioning a plate element a first distance from said sputtering surface, said first distance being less than said first thickness and said plate element including a bottom surface and at least one edge;
  - inhibiting plasma formation in a first area adjacent said bottom surface by absorbing electrons emitted from said target such that target material is not eroded from a predetermined first portion of said sputtering surface opposite said first area;
  - forming plasma in a second area adjacent said edge to cause target material to be eroded from a predetermined second portion of said sputtering surface opposite said second area, thereby forming a desired non-uniform erosion pattern on said sputtering surface for improving thickness uniformity of said film.
9. The method according to claim 8, wherein said plate includes at least one hole to form first and second edges.

10. The method according to claim 8, wherein said plate element includes at least two concentric rings.
11. The method according to claim 8, wherein said plate element is a solid plate.
12. The method according to claim 8, wherein said plate element is maintained at a potential which is positive relative to said target.
13. The method according to claim 8, wherein said plate element is grounded.
14. The method according to claim 8, wherein said first distance is between approximately 0.05 and 1.0 inches.
15. A sputtering system for depositing a thin film on a substrate, comprising:
  - an evacuable chamber;
  - a target positioned within said chamber, said target including a sputtering surface;
  - biasing means for biasing said target to form a cathode element which emits electrons;
  - an anode element which includes said substrate, wherein said substrate is positioned opposite said cathode element in said chamber;
  - ionization means for ionizing a sputtering gas, in response to said electrons, to form a plasma for eroding target material from said sputtering surface which is then deposited on said substrate to form said film, said plasma including a cathode dark space having a first thickness wherein ionization does not occur; and
  - a plate element having first and second outer edges and at least one hole to form first and second inner edges and first and second bottom surfaces, said plate element being grounded and spaced apart from said sputtering surface by a first distance which is between approximately 0.05 and 1.0 inches and which is less than said first thickness, wherein electrons emitted from said target are absorbed by said plate element to selectively inhibit plasma formation in first areas adjacent said first and second bottom surfaces such that target material is not eroded from predetermined first portions of said sputtering surface opposite said first areas, and wherein plasma is formed in a second areas adjacent said first and second inner and outer edges to cause

target material to be eroded from predetermined second portions of said sputtering surface opposite said second areas, thereby forming a desired non-uniform erosion pattern on said sputtering surface for improving thickness uniformity of said film.

16. The system according to claim 15, wherein said plate element includes at least two concentric rings.

17. The system according to claim 15, wherein said plate element is a solid plate.

18. The system according to claim 15, wherein said plate element is maintained at a potential which is positive relative to said target.



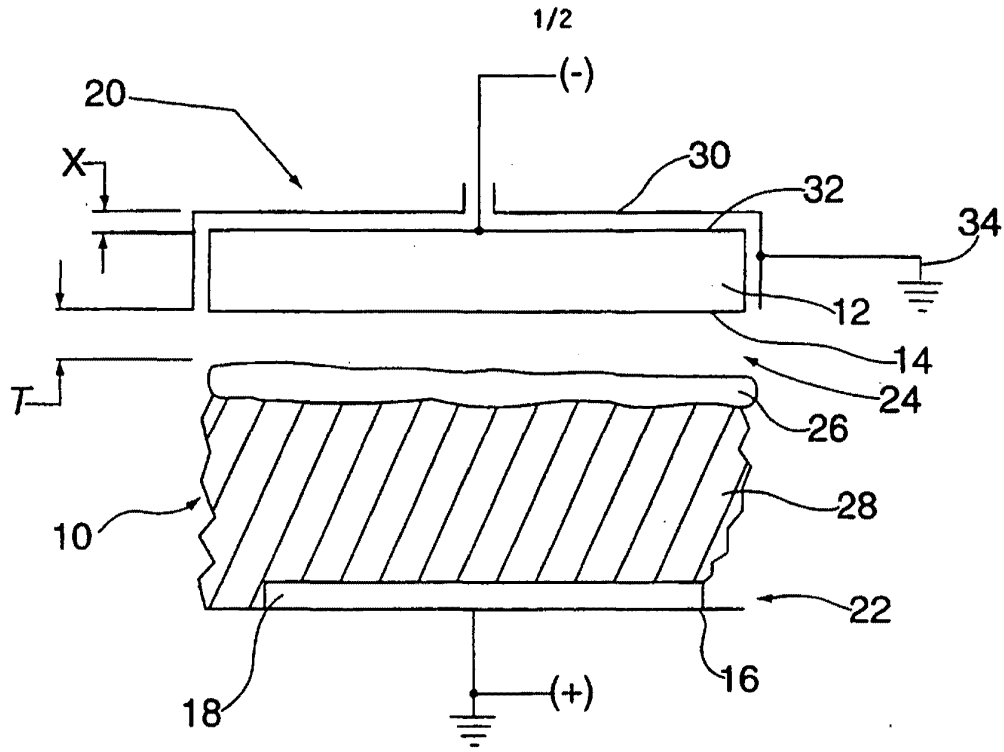


FIG. 1

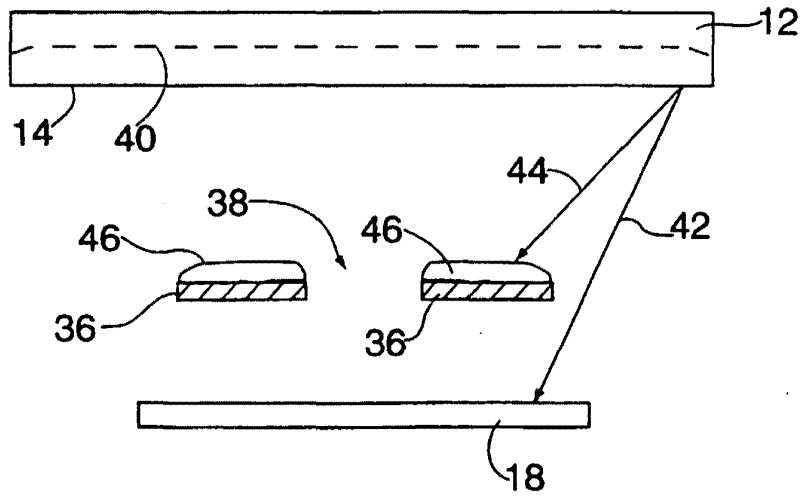


FIG. 2

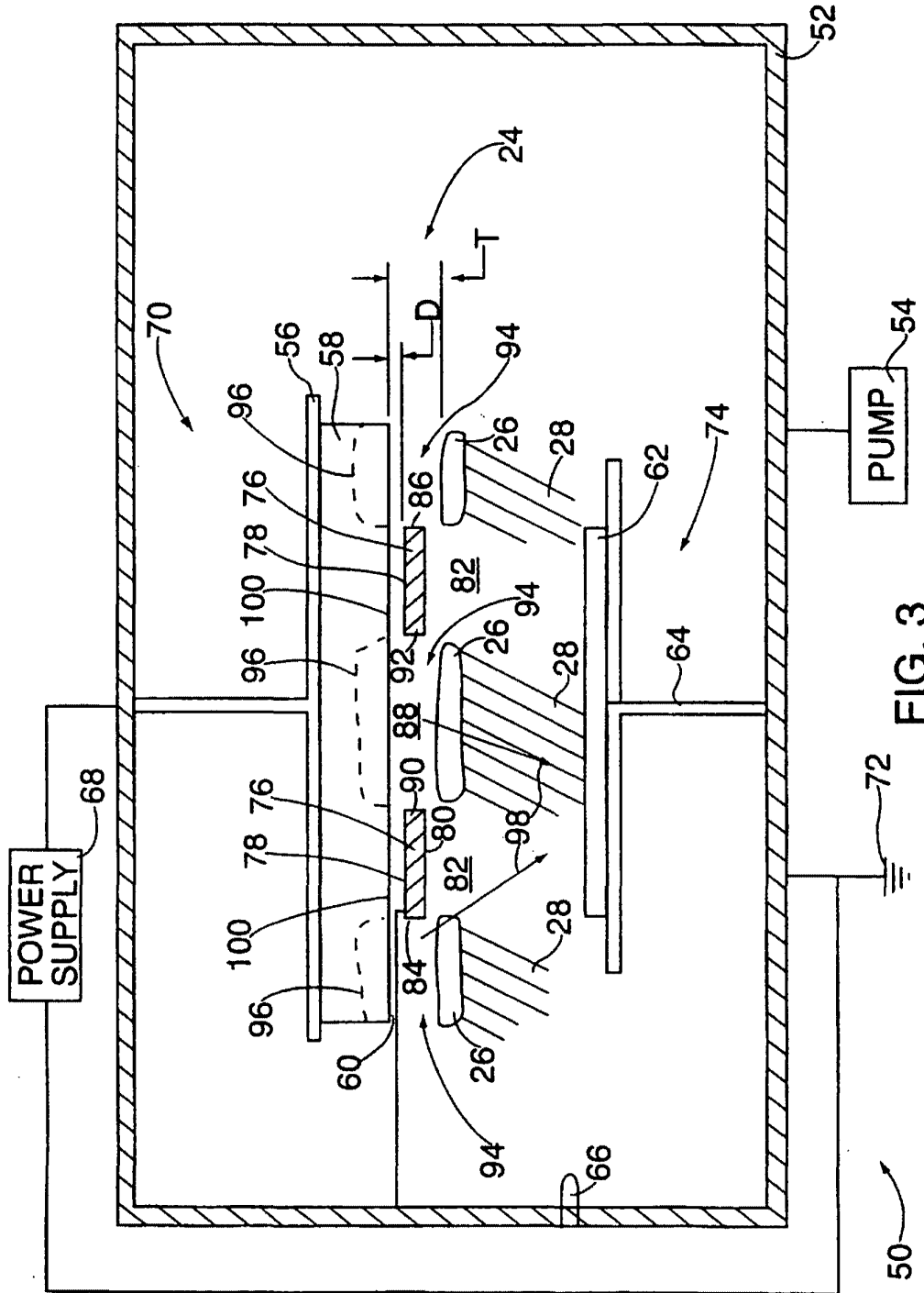


FIG. 3

INTERNATIONAL SEARCH REPORT

International application No.  
PCT/US97/03047

<b>A. CLASSIFICATION OF SUBJECT MATTER</b>																							
IPC(6) : C23C 14/40 US CL : 204/192.12, 298.06, 298.11, 298.14, 298.15 According to International Patent Classification (IPC) or to both national classification and IPC																							
<b>B. FIELDS SEARCHED</b>																							
Minimum documentation searched (classification system followed by classification symbols) U.S. : 204/192.12, 298.06, 298.11, 298.14, 298.15																							
Documentation searched other than minimum documentation to the extent that such documents are included in the fields searched None																							
Electronic data base consulted during the international search (name of data base and, where practicable, search terms used) None																							
<b>C. DOCUMENTS CONSIDERED TO BE RELEVANT</b>																							
Category*	Citation of document, with indication, where appropriate, of the relevant passages	Relevant to claim No.																					
Y	US 4,824,544 A (MIKALESEN et al) 25 April 1989, Column 4 lines 64-68; Column 5 lines 1-5, lines 10-13, lines 54-65, lines 66-68; Column 6 lines 1-3.	1-18																					
Y	US 4,508,612 A (BLACKWELL et al) 02 April 1985, Column 3 lines 49-52; Column 5 lines 16-25, lines 26-36; Column 7 lines 21-27; Figure 2.	1-18																					
Y	US 3,985,635 A (ADAM et al) 12 October 1976, Column 2 lines 37-44, lines 45-50, lines 51-68; Column 3 lines 1-22, lines 60-63; Column 4 lines 18-23, lines 33-55; Column 6 lines 9-24.	1-18																					
<input checked="" type="checkbox"/> Further documents are listed in the continuation of Box C. <input type="checkbox"/> See patent family annex.																							
<table border="0"> <tr> <td>* Special categories of cited documents:</td> <td>* T</td> <td>later document published after the international filing date or priority date and not in conflict with the application but cited to understand the principle or theory underlying the invention</td> </tr> <tr> <td>* A</td> <td></td> <td>document defining the general state of the art which is not considered to be of particular relevance</td> </tr> <tr> <td>* E</td> <td>* X</td> <td>document of particular relevance; the claimed invention cannot be considered novel or cannot be considered to involve an inventive step when the document is taken alone</td> </tr> <tr> <td>* L</td> <td>* Y</td> <td>document of particular relevance; the claimed invention cannot be considered to involve an inventive step when the document is combined with one or more other such documents, such combination being obvious to a person skilled in the art</td> </tr> <tr> <td>* O</td> <td></td> <td>document referring to an oral disclosure, use, exhibition or other means</td> </tr> <tr> <td>* P</td> <td>* A</td> <td>document member of the same patent family</td> </tr> <tr> <td></td> <td></td> <td>document published prior to the international filing date but later than the priority date claimed</td> </tr> </table>			* Special categories of cited documents:	* T	later document published after the international filing date or priority date and not in conflict with the application but cited to understand the principle or theory underlying the invention	* A		document defining the general state of the art which is not considered to be of particular relevance	* E	* X	document of particular relevance; the claimed invention cannot be considered novel or cannot be considered to involve an inventive step when the document is taken alone	* L	* Y	document of particular relevance; the claimed invention cannot be considered to involve an inventive step when the document is combined with one or more other such documents, such combination being obvious to a person skilled in the art	* O		document referring to an oral disclosure, use, exhibition or other means	* P	* A	document member of the same patent family			document published prior to the international filing date but later than the priority date claimed
* Special categories of cited documents:	* T	later document published after the international filing date or priority date and not in conflict with the application but cited to understand the principle or theory underlying the invention																					
* A		document defining the general state of the art which is not considered to be of particular relevance																					
* E	* X	document of particular relevance; the claimed invention cannot be considered novel or cannot be considered to involve an inventive step when the document is taken alone																					
* L	* Y	document of particular relevance; the claimed invention cannot be considered to involve an inventive step when the document is combined with one or more other such documents, such combination being obvious to a person skilled in the art																					
* O		document referring to an oral disclosure, use, exhibition or other means																					
* P	* A	document member of the same patent family																					
		document published prior to the international filing date but later than the priority date claimed																					
Date of the actual completion of the international search 27 MARCH 1997		Date of mailing of the international search report 13.05.97																					
Name and mailing address of the ISA/US Commissioner of Patents and Trademarks Box PCT Washington, D.C. 20231 Facsimile No. (703) 305-3230		Authorized officer <i>Rodney McDonald</i> RODNEY MCDONALD Telephone No. (703) 308 - 3807																					

Form PCT/ISA/210 (second sheet)(July 1992)\*

INTERNATIONAL SEARCH REPORT

International application No.  
PCT/US97/03047

C (Continuation). DOCUMENTS CONSIDERED TO BE RELEVANT		
Category*	Citation of document, with indication, where appropriate, of the relevant passages	Relevant to claim No.
Y	US 3,361,659 A (BERTELSEN) 02 January 1968, Column 3 lines 50-57, lines 63-68; Column 4 lines 60-75; Column 5 lines 1-17, lines 27-30; Column 6 lines 32-34.	1-18

Form PCT/ISA/210 (continuation of second sheet)(July 1992)\*

**PATENT APPLICATION FEE DETERMINATION RECORD**

Effective October 1, 2001

Application or Docket Number

**CLAIMS AS FILED - PART I**

	(Column 1)	(Column 2)
TOTAL CLAIMS	39	
FOR	NUMBER FILED	NUMBER EXTRA
TOTAL CHARGEABLE CLAIMS	39 minus 20 = *	19
INDEPENDENT CLAIMS	5 minus 3 = *	2
MULTIPLE DEPENDENT CLAIM PRESENT <input type="checkbox"/>		

\* If the difference in column 1 is less than zero, enter "0" in column 2

*Amend  
7-23-04*

**CLAIMS AS AMENDED - PART II**

	(Column 1)	(Column 2)	(Column 3)
AMENDMENT A	CLAIMS REMAINING AFTER AMENDMENT	HIGHEST NUMBER PREVIOUSLY PAID FOR	PRESENT EXTRA
	Total * 19	Minus ** 39	= -
	Independent * 2	Minus *** 5	= -
FIRST PRESENTATION OF MULTIPLE DEPENDENT CLAIM <input type="checkbox"/>			

	(Column 1)	(Column 2)	(Column 3)
AMENDMENT B	CLAIMS REMAINING AFTER AMENDMENT	HIGHEST NUMBER PREVIOUSLY PAID FOR	PRESENT EXTRA
	Total *	Minus **	=
	Independent *	Minus ***	=
FIRST PRESENTATION OF MULTIPLE DEPENDENT CLAIM <input type="checkbox"/>			

	(Column 1)	(Column 2)	(Column 3)
AMENDMENT C	CLAIMS REMAINING AFTER AMENDMENT	HIGHEST NUMBER PREVIOUSLY PAID FOR	PRESENT EXTRA
	Total *	Minus **	=
	Independent *	Minus ***	=
FIRST PRESENTATION OF MULTIPLE DEPENDENT CLAIM <input type="checkbox"/>			

\* If the entry in column 1 is less than the entry in column 2, write "0" in column 3.

\*\* If the "Highest Number Previously Paid For" IN THIS SPACE is less than 20, enter "20."

\*\*\* If the "Highest Number Previously Paid For" IN THIS SPACE is less than 3, enter "3."

The "Highest Number Previously Paid For" (Total or Independent) is the highest number found in the appropriate box in column 1.

SMALL ENTITY TYPE

OR OTHER THAN SMALL ENTITY

RATE	FEE
BASIC FEE	370.00
9 X \$ 9 =	171
2 X 42 =	84
+140 =	
TOTAL	625

RATE	FEE
BASIC FEE	740.00
X \$ 18 =	
X 84 =	
+280 =	
TOTAL	

SMALL ENTITY

OR OTHER THAN SMALL ENTITY

RATE	ADDITIONAL FEE
X \$ 9 =	
X 42 =	
+140 =	
TOTAL ADDIT. FEE	

RATE	ADDITIONAL FEE
X \$ 18 =	
X 84 =	
+280 =	
TOTAL ADDIT. FEE	

RATE	ADDITIONAL FEE
X \$ 9 =	
X 42 =	
+140 =	
TOTAL ADDIT. FEE	

RATE	ADDITIONAL FEE
X \$ 18 =	
X 84 =	
+280 =	
TOTAL ADDIT. FEE	

RATE	ADDITIONAL FEE
X \$ 9 =	
X 42 =	
+140 =	
TOTAL ADDIT. FEE	

RATE	ADDITIONAL FEE
X \$ 18 =	
X 84 =	
+280 =	
TOTAL ADDIT. FEE	

BEST AVAILABLE COPY





21823 1A  
✓  
IFW

PATENT  
Customer No. 22,852  
Attorney Docket No. 09140-0016-00000

IN THE UNITED STATES PATENT AND TRADEMARK OFFICE

In re Application of:	)	
	)	
H. Zhang, et al.	)	Group Art Unit: 2823
	)	
Application No.: 10/101,863	)	Examiner: Michelle Estrada
	)	
Filed: March 16, 2002	)	Confirmation No.: 6938
	)	
For: BIASED PULSED DC REACTIVE	)	
SPUTTERING OF OXIDE FILMS	)	

Mail Stop AMENDMENTS  
Commissioner for Patents  
P.O. Box 1450  
Alexandria, VA 22313-1450

Sir:

**SUPPLEMENTAL INFORMATION DISCLOSURE STATEMENT**  
**UNDER 37 C.F.R. § 1.97(c)**

Pursuant to 37 C.F.R. §§ 1.56 and 1.97(c), Applicants brings to the attention of the Examiner the documents listed on the attached PTO 1449. This Information Disclosure Statement is being filed after the events recited in Section 1.97(b) but, to the undersigned's knowledge, before the mailing date of either a Final action, Quayle action, or a Notice of Allowance. Under the provisions of 37 C.F.R. § 1.97(c), this Information Disclosure Statement is accompanied by a fee of \$180.00 as specified by Section 1.17(p).

Copies of the listed documents are attached.

Applicants respectfully request that the Examiner consider the listed documents and indicate that they were considered by making appropriate notations on the attached form.

03/03/2004 SDIRETR1 00000004 10101863

01 FC:1800

180.00 UP

This submission does not represent that a search has been made or that no better art exists and does not constitute an admission that each or all of the listed documents are material or constitute "prior art." If the Examiner applies any of the documents as prior art against any claims in the application and Applicants determine that the cited documents do not constitute "prior art" under United States law, Applicants reserve the right to present to the office the relevant facts and law regarding the appropriate status of such documents.

Applicants further reserve the right to take appropriate action to establish the patentability of the disclosed invention over the listed documents, should one or more of the documents be applied against the claims of the present application.

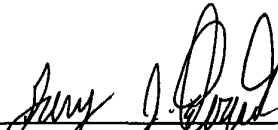
If there is any additional fee due in connection with the filing of this Statement, please charge the fee to our Deposit Account No. 06-0916.

Respectfully submitted,

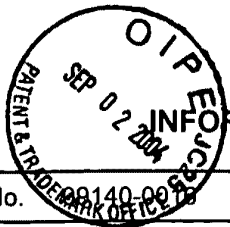
FINNEGAN, HENDERSON, FARABOW,  
GARRETT & DUNNER, L.L.P.

Dated: September 1, 2004

By: \_\_\_\_\_

  
Gary J. Edwards  
Reg. No. 41,008





OMB No. 0651-0011

INFORMATION DISCLOSURE CITATION

Atty. Docket No. 09140-09	Appln. No. 10/101,863
Applicant ZHANG et al.	
Filing Date March 16, 2002	Group: 2823

U.S. PATENT DOCUMENTS						
Examiner Initial*	Document Number	Issue Date	Name	Class	Sub Class	Filing Date If Appropriate
	3,616,403	Oct. 26, 1971	Collins et al.	204	192	
	3,850,604	Nov. 26, 1974	Klein	65	32	
	4,111,523	Sep. 5, 1978	Kaminow et al.	350	96.14	
	4,619,680	Oct. 28, 1986	Nourshargh et al.	65	3.12	
	5,196,041	Mar. 23, 1993	Tumminelli et al.	65	30.1	
	5,287,427	Feb. 15, 1994	Atkins et al.	385	124	
	6,511,615 B1	Jan. 28, 2003	Dawes et al.	264	1.21	
	6,563,998 B1	May 13, 2003	Farah et al.	385	131	
	6,605,228 B1	Aug. 12, 2003	Kawaguchi et al.	216	24	
	6,615,614 B1	Sep. 9, 2003	Makikawa et al.	65	386	

FOREIGN PATENT DOCUMENTS							
	Document Number	Publication Date	Country	Class	Sub Class	Translation Yes or No	

OTHER DOCUMENTS (Including Author, Title, Date, Pertinent Pages, Etc.)	

Examiner	Date Considered
*Examiner: Initial if reference considered, whether or not citation is in conformance with MPEP 609; draw line through citation if not in conformance and not considered. Include copy of this form with next communication to applicant.	
Form PTO 1449	Patent and Trademark Office - U.S. Department of Commerce



UNITED STATES PATENT AND TRADEMARK OFFICE

UNITED STATES DEPARTMENT OF COMMERCE  
United States Patent and Trademark Office  
Address: COMMISSIONER FOR PATENTS  
P.O. Box 1450  
Alexandria, Virginia 22313-1450  
www.uspto.gov

APPLICATION NO.	FILING DATE	FIRST NAMED INVENTOR	ATTORNEY DOCKET NO.	CONFIRMATION NO.
10/101,863	03/16/2002	Hongmei Zhang	M-12245 US	6938

7590 10/06/2004  
Skjerven Morrill Macpherson LLP  
Suite 700  
250 Metro Drive  
San Jose, CA 95110

EXAMINER


ESTRADA, MICHELLE

ART UNIT PAPER NUMBER

2823

DATE MAILED: 10/06/2004

Please find below and/or attached an Office communication concerning this application or proceeding.

<b>Office Action Summary</b>	<b>Application No.</b> 10/101,863	<b>Applicant(s)</b> ZHANG ET AL.	
	<b>Examiner</b> Michelle Estrada	<b>Art Unit</b> 2823	

-- The MAILING DATE of this communication appears on the cover sheet with the correspondence address --

**Period for Reply**

A SHORTENED STATUTORY PERIOD FOR REPLY IS SET TO EXPIRE 3 MONTH(S) FROM THE MAILING DATE OF THIS COMMUNICATION.

- Extensions of time may be available under the provisions of 37 CFR 1.136(a). In no event, however, may a reply be timely filed after SIX (6) MONTHS from the mailing date of this communication.
- If the period for reply specified above is less than thirty (30) days, a reply within the statutory minimum of thirty (30) days will be considered timely.
- If NO period for reply is specified above, the maximum statutory period will apply and will expire SIX (6) MONTHS from the mailing date of this communication.
- Failure to reply within the set or extended period for reply will, by statute, cause the application to become ABANDONED (35 U.S.C. § 133). Any reply received by the Office later than three months after the mailing date of this communication, even if timely filed, may reduce any earned patent term adjustment. See 37 CFR 1.704(b).

**Status**

- 1)  Responsive to communication(s) filed on 23 July 2004.
- 2a)  This action is **FINAL**.                      2b)  This action is non-final.
- 3)  Since this application is in condition for allowance except for formal matters, prosecution as to the merits is closed in accordance with the practice under *Ex parte Quayle*, 1935 C.D. 11, 453 O.G. 213.

**Disposition of Claims**

- 4)  Claim(s) 1-14 and 20-24 is/are pending in the application.
  - 4a) Of the above claim(s) \_\_\_\_\_ is/are withdrawn from consideration.
- 5)  Claim(s) \_\_\_\_\_ is/are allowed.
- 6)  Claim(s) 1-13 and 20 is/are rejected.
- 7)  Claim(s) 7, 14 and 21-24 is/are objected to.
- 8)  Claim(s) \_\_\_\_\_ are subject to restriction and/or election requirement.

**Application Papers**

- 9)  The specification is objected to by the Examiner.
- 10)  The drawing(s) filed on \_\_\_\_\_ is/are: a)  accepted or b)  objected to by the Examiner.  
 Applicant may not request that any objection to the drawing(s) be held in abeyance. See 37 CFR 1.85(a).  
 Replacement drawing sheet(s) including the correction is required if the drawing(s) is objected to. See 37 CFR 1.121(d).
- 11)  The oath or declaration is objected to by the Examiner. Note the attached Office Action or form PTO-152.

**Priority under 35 U.S.C. § 119**

- 12)  Acknowledgment is made of a claim for foreign priority under 35 U.S.C. § 119(a)-(d) or (f).
    - a)  All    b)  Some \*    c)  None of:
      - 1.  Certified copies of the priority documents have been received.
      - 2.  Certified copies of the priority documents have been received in Application No. \_\_\_\_\_.
      - 3.  Copies of the certified copies of the priority documents have been received in this National Stage application from the International Bureau (PCT Rule 17.2(a)).
- \* See the attached detailed Office action for a list of the certified copies not received.

**Attachment(s)**

- 1)  Notice of References Cited (PTO-892)
- 2)  Notice of Draftsperson's Patent Drawing Review (PTO-948)
- 3)  Information Disclosure Statement(s) (PTO-1449 or PTO/SB/08)  
 Paper No(s)/Mail Date 7/23/04, 9/2/04.
- 4)  Interview Summary (PTO-413)  
 Paper No(s)/Mail Date. \_\_\_\_\_.
- 5)  Notice of Informal Patent Application (PTO-152)
- 6)  Other: \_\_\_\_\_.

## DETAILED ACTION

### *Claim Objections*

Claim 14 is objected to because of the following informalities: in line 2, it appears that "12" should be deleted. Appropriate correction is required.

### *Claim Rejections - 35 USC § 103*

The following is a quotation of 35 U.S.C. 103(a) which forms the basis for all obviousness rejections set forth in this Office action:

(a) A patent may not be obtained though the invention is not identically disclosed or described as set forth in section 102 of this title, if the differences between the subject matter sought to be patented and the prior art are such that the subject matter as a whole would have been obvious at the time the invention was made to a person having ordinary skill in the art to which said subject matter pertains. Patentability shall not be negated by the manner in which the invention was made.

Claims 1-13 and 20 are rejected under 35 U.S.C. 103(a) as being unpatentable over the combination of Le et al. (2003/0077914) and Fukui et al. (5,755,938).

With respect to claim 1, Le et al. disclose providing pulsed DC power (22) to a target (14) (Page 4, Paragraph [0070]); providing bias power to a substrate (16) positioned opposite the target (Page 5, lines 13-14); providing process gas between the target and the substrate (Page 4, Paragraph [0067]).

With respect to claim 7, Le et al. disclose wherein the film is an upper cladding layer of a waveguide structure and the bias power is optimized to provide planarization Page 5, Paragraph [0075].

With respect to claim 8, Le et al. disclose wherein the process gas includes a mixture of oxygen and argon (Page 4, Paragraph [0067]).

With respect to claim 9, Le et al. disclose wherein the oxygen flow is adjusted to adjust the index of refraction of the film (Page 5, Paragraph [0076]).

With respect to claim 10, Le et al. disclose wherein the process gas further includes nitrogen (Page 5, Paragraph [0074]).

With respect to claim 11, Le et al. disclose wherein providing pulsed DC power to a target includes providing pulsed DC power to a target which has an area larger than that of the substrate (See fig. 3).

With respect to claim 12, Le et al. disclose further including uniformly sweeping the target with a magnetic field (Page 5, Paragraph [0073]).

With respect to claim 13, Le et al. disclose wherein uniformly sweeping the target with a magnetic field includes sweeping a magnet in one direction across the target where the magnet extends beyond the target in the opposite direction (Page 5, Paragraph [0073]).

With respect to claim 20, Le et al. disclose conditioning a target (Page 4, Paragraph [0070]); preparing the substrate (Page 3, Paragraph [0065]); adjusting the bias power to the substrate (Page 4, Paragraph [0041]); setting the process gas flow (Page 4, Paragraph [0067]); and applying pulsed DC power to the target to deposit the film (Page 4, Paragraph [0071]).

With respect to claims 2-4 and 6, One of ordinary skill in the art would have been led to the recited temperature, DC power, time pulse and bias power to routine experimentation to achieve a desire layer thickness, device dimension, device associated characteristics and device density on the finished wafer in view of the range

Art Unit: 2823

of values disclosed. Furthermore, Le et al. disclose that sets of process parameters depend on the specific process chamber (Page 6, Paragraph [0081]).

In addition, the selection of temperature, DC power, time pulse and bias power, its obvious because it is a matter of determining optimum process conditions by routine experimentation with a limited number of species of result effective variables. These claims are prima facie obvious without showing that the claimed ranges achieve unexpected results relative to the prior art range. In re Woodruff, 16 USPQ2d 1935, 1937 (Fed. Cir. 1990). See also In re Huang, 40 USPQ2d 1685, 1688 (Fed. Cir. 1996)(claimed ranges or a result effective variable, which do not overlap the prior art ranges, are unpatentable unless they produce a new and unexpected result which is different in kind and not merely in degree from the results of the prior art). See also In re Boesch, 205 USPQ 215 (CCPA) (discovery of optimum value of result effective variable in known process is ordinarily within skill or art) and In re Aller, 105 USPQ 233 (CCPA 1995) (selection of optimum ranges within prior art general conditions is obvious).

Note that the specification contains no disclosure of either the critical nature of the claimed temperature, DC power, time pulse and bias power or any unexpected results arising therefrom. Where patentability is said to be based upon particular chosen temperature, DC power, time pulse and bias power or upon another variable recited in a claim, the Applicant must show that the chosen temperature, DC power, time pulse and bias power are critical. In re Woodruff, 919 F.2d 1575, 1578, 16 USPQ2d 1934, 1936 (Fed. Cir. 1990).

Le et al. do not disclose providing a DC power through a filter.

With respect to claims 1 and 5, Fukui et al. disclose a sputtering process wherein the DC power supply (28) is connected through a band-pass filter.

It would have been within the scope of one of ordinary skill in the art to combine the teachings of Le et al. and Fukui et al. to enable the use of a DC power supply through a filter to be used in the process of Le et al. to adjust the impedance to have an infinite value so that no RF waves are superposed on a DC power from the DC power supply (Col. 6, lines 32-37).

#### ***Allowable Subject Matter***

Claims 7, 14 and 21-24 are objected to as being dependent upon a rejected base claim, but would be allowable if rewritten in independent form including all of the limitations of the base claim and any intervening claims.

#### ***Response to Arguments***

Applicant's arguments filed 7/23/04 have been fully considered but they are not persuasive. Applicant argues that Le et al. do not disclose a bias applied to the substrate. However, Applicant is directed to Page 5, lines 13-14, wherein Le et al. disclose applying a RF energy (bias) to the gas supplied to the substrate.

Applicant argues that Fukui does not teach a pulsed DC power supply. However, Fukui was not relied on upon for that purpose. Fukui teaches supplying power from a DC supply through a filter to the target. Fukui was relied on for the use of a filter to supply a power to the target.

In response to applicant's argument that the examiner's conclusion of obviousness is based upon improper hindsight reasoning, it must be recognized that any judgment on obviousness is in a sense necessarily a reconstruction based upon hindsight reasoning. But so long as it takes into account only knowledge which was within the level of ordinary skill at the time the claimed invention was made, and does not include knowledge gleaned only from the applicant's disclosure, such a reconstruction is proper. See *In re McLaughlin*, 443 F.2d 1392, 170 USPQ 209 (CCPA 1971).

Applicant argues that utilizing a filter provided for a DC power supply is not obvious and may not be necessary in the system taught by Le because of the lack of a bias. However, Le discloses applying a bias to energize the gas being applied to the substrate, as explained above. Therefore, a filter may be used to provide the pulsed DC power through the filter since a bias is being applied.

Applicant argues that there is no suggestion in Fukui that a pulsed DC power supply can be substituted for the RF power supply coupled to the target, nor would one skilled in the art be inclined to replace that RF power supply with a pulsed DC power supply. However, the Examiner is not substituting the pulsed DC power supply for the



RF power supply coupled to the target. The rejection is based on utilizing the filter of Fukui to be used in the pulsed DC power supply of Le.

**THIS ACTION IS MADE FINAL.** Applicant is reminded of the extension of time policy as set forth in 37 CFR 1.136(a).

A shortened statutory period for reply to this final action is set to expire THREE MONTHS from the mailing date of this action. In the event a first reply is filed within TWO MONTHS of the mailing date of this final action and the advisory action is not mailed until after the end of the THREE-MONTH shortened statutory period, then the shortened statutory period will expire on the date the advisory action is mailed, and any extension fee pursuant to 37 CFR 1.136(a) will be calculated from the mailing date of the advisory action. In no event, however, will the statutory period for reply expire later than SIX MONTHS from the mailing date of this final action.


Any inquiry concerning this communication or earlier communications from the examiner should be directed to Michelle Estrada whose telephone number is 571-272-1858. The examiner can normally be reached on Monday through Friday.


If attempts to reach the examiner by telephone are unsuccessful, the examiner's supervisor, Olik Chaudhuri can be reached on 571-272-1855. The fax phone numbers for the organization where this application or proceeding is assigned are 703-308-7722 for regular communications and 703-308-7724 for After Final communications.

Application/Control Number: 10/101,863  
Art Unit: 2823

Page 8

Any inquiry of a general nature or relating to the status of this application or proceeding should be directed to the receptionist whose telephone number is 571-272-2800.

  
MEstrada  
October 4, 2004

  
Olik Chaudhuri  
Supervisory Patent Examiner  
Technology Center 2800



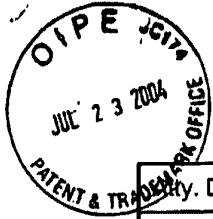
OMB No. 0651-0011

**INFORMATION DISCLOSURE CITATION**

Atty. Docket No.	09140-0016	Appln. No.	10/101,863
Applicant	ZHANG et al.		
Filing Date	March 16, 2002	Group:	2823

U.S. PATENT DOCUMENTS						
Examiner Initial*	Document Number	Issue Date	Name	Class	Sub Class	Filing Date If Appropriate
<i>ME</i>	2002/0106297		Ueno et al.	419	12	Aug. 08, 2002
<i>ME</i>	2003/0019326		Han et al.	45	245	Jan. 30, 2003
<i>ME</i>	2003/0063883		Demaray et al.	385	129	Apr. 3, 2003
<i>ME</i>	2003/0175142		Milonopoulou et al.	419	49	Sep. 18, 2003
<i>ME</i>	4,437,966	Mar. 7, 1961	Hope et al	204	298	
<i>ME</i>	4,915,810	Apr. 10, 1990	Kestigian et al.	204	298.04	
<i>ME</i>	4,978,437	Dec. 18, 1990	Wirz	204	192.	
<i>ME</i>	5,174,876	Dec. 29, 1992	Buchal et al.	427	526	
<i>ME</i>	5,200,029	Apr. 6, 1993	Bruce et al.	156	657	
<i>ME</i>	5,206,925	Apr. 27, 1993	Nakazawa et al.	385	142	
<i>ME</i>	5,225,288	Jul. 6, 1993	Beeson et al.	428	475.5	
<i>ME</i>	5,237,439	Aug. 17, 1993	Misono et al.	359	74	
<i>ME</i>	5,252,194	Oct. 12, 1993	Demaray et al.	204	298	
<i>ME</i>	5,303,319	Apr. 12, 1994	Ford et al.	385	131	
<i>ME</i>	5,381,262	Jan. 10, 1995	Arima et al.	359	341	
<i>ME</i>	5,427,669	Jun. 27, 1995	Drummond	204	298.2	
<i>ME</i>	5,475,528	Dec. 12, 1995	LaBorde	359	341	
<i>ME</i>	5,483,613	Jan. 9, 1996	Bruce et al.	385	129	
<i>ME</i>	5,555,127	Sep. 10, 1996	Abdelkader et al.	359	341	
<i>ME</i>	5,565,071	Oct. 15, 1996	Demaray et al.	204	192	
<i>ME</i>	5,603,816	Feb. 18, 1997	Demaray et al.	204	298	

Examiner	<i>Michelle Estrade</i>	Date Considered	<i>9/28/04</i>
*Examiner: Initial if reference considered, whether or not citation is in conformance with MPEP 609; draw line through citation if not in conformance and not considered. Include copy of this form with next communication to applicant.			
Form PTO 1449		Patent and Trademark Office - U.S. Department of Commerce	



OMB No. 0651-0011

INFORMATION DISCLOSURE CITATION

Patent No. Docket No.	09140-0016	Appln. No.	10/101,863
Applicant	ZHANG et al.		
Filing Date	March 16, 2002	Group:	2823

U.S. PATENT DOCUMENTS						
Examiner Initial*	Document Number	Issue Date	Name	Class	Sub Class	Filing Date If Appropriate
<i>ME</i>	5,613,995	Mar. 25, 1997	Bhandarkar et al.	65	384	
<i>ME</i>	5,654,054	Aug. 5, 1997	Tropsha et al.	428	36.6	
<i>ME</i>	5,693,956	Dec. 2, 1997	Shi et al.	257	40	
<i>ME</i>	5,718,813	Feb. 17, 1998	Drummond	204	192.2	
<i>ME</i>	5,719,976	Feb. 17, 1998	Henry et al.	385	50	
<i>ME</i>	5,792,550	Aug. 11, 1998	Phillips et al.	428	336	
<i>ME</i>	5,841,931	Nov. 24, 1998	Foresi et al.	385	131	
<i>ME</i>	5,847,865	Dec. 8, 1998	Gopinath et al.	359	343	
<i>ME</i>	5,855,744	Jan. 5, 1999	Halsey et al.	204	192	
<i>ME</i>	5,948,215	Sep. 7, 1999	Lantsman	204	192.12	
<i>ME</i>	5,961,682	Oct. 5, 1999	Lee et al.	65	384	
<i>ME</i>	5,977,582	Nov. 2, 1999	Fleming et al.	257	310	
<i>ME</i>	6,001,224	Dec. 14, 1999	Drummond	204	192.12	
<i>ME</i>	6,024,844	Feb. 15, 2000	Drummond et al.	204	192.12	
<i>ME</i>	6,051,114	Apr. 18, 2000	Yao et al.	204	192.3	
<i>ME</i>	6,093,944	Jul. 25, 2000	VanDover	257	310	
<i>ME</i>	6,162,709	Dec. 19, 2000	Raux et al.	438	513	
<i>ME</i>	6,176,986	Jan. 23, 2001	Watanabe et al.	204	298.13	
<i>ME</i>	6,248,291	Jun. 19, 2001	Nakagama et al.	419	46	
<i>ME</i>	6,280,585 B1	Aug. 28, 2001	Obinata et al.	204	298.19	
<i>ME</i>	6,287,986	Sep. 11, 2001	Mihara	438	763	

Examiner	<i>Michelle Stradw</i>	Date Considered	<i>9/28/04</i>
*Examiner: Initial if reference considered, whether or not citation is in conformance with MPEP 609; draw line through citation if not in conformance and not considered. Include copy of this form with next communication to applicant.			
Form PTO 1449		Patent and Trademark Office - U.S. Department of Commerce	



OMB No. 0651-0011

INFORMATION DISCLOSURE CITATION

Pat. Docket No.	09140-0016	Appln. No.	10/101,863
Applicant	ZHANG et al.		
Filing Date	March 16, 2002	Group:	2823

U.S. PATENT DOCUMENTS						
Examiner Initial*	Document Number	Issue Date	Name	Class	Sub Class	Filing Date If Appropriate
<i>ME</i>	6,290,822	Sep. 18, 2001	Fleming et al.	204	192.22	
<i>ME</i>	6,344,419	Feb. 5, 2002	Forster et al.	438	758	
<i>ME</i>	6,350,353	Feb. 26, 2002	Gopalraja et al.	204	192.3	
<i>ME</i>	6,358,810	Mar. 19, 2002	Dornfest et al.	438	396	
<i>ME</i>	6,409,965	Jun. 25, 2002	Nagate et al.	419	26	
<i>ME</i>	6,413,382	Jul. 2, 2002	Wang et al.	204	192.12	
<i>ME</i>	6,537,428	Mar. 25, 2003	Xiong et al.	204	192.13	
<i>ME</i>	6,602,338	Aug. 5, 2003	Chen et al.	252	301.4	

FOREIGN PATENT DOCUMENTS						
	Document Number	Publication Date	Country	Class	Sub Class	Translation Yes or No
<i>ME</i>	EP 0 820 088	01/21/98	Europe	H 01 J	37/34	
<i>ME</i>	EP 0 867 985 A1	09/01/98	Europe	H 01 S	3/06	
<i>ME</i>	JP 6-010127	01/18/94	Japan	C 23 C	14/35	Abstract
<i>ME</i>	JP 6-100333	12/04/94	Japan	C 03 C	21/00	Abstract
<i>ME</i>	WO 00/22742	04/01/00	PCT	H 04 B		
<i>ME</i>	WO 00/36665	06/22/00	PCT	H 01 L	51/20	
<i>ME</i>	WO 02/12932	02/14/02	PCT	H 01 S	3/16	
<i>ME</i>	WO 96/23085	08/01/96	PCT	C 23 C	14/34	
<i>ME</i>	WO 97/35044	09/25/97	PCT	C 23 C	14/40	

Examiner <i>Michelle Estrada</i>	Date Considered <i>9/2/04</i>
*Examiner: Initial if reference considered, whether or not citation is in conformance with MPEP 609; draw line through citation if not in conformance and not considered. Include copy of this form with next communication to applicant.	
Form PTO 1449	Patent and Trademark Office - U.S. Department of Commerce



OMB No. 0651-0011

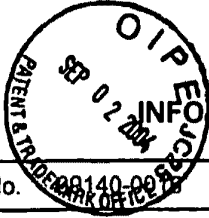
INFORMATION DISCLOSURE CITATION

Patent No. / Docket No.	09140-0016	Appln. No.	10/101,863
Applicant	ZHANG et al.		
Filing Date	March 16, 2002	Group:	2823

OTHER DOCUMENTS (Including Author, Title, Date, Pertinent Pages, Etc.)	
<i>me</i>	BARBIER, Denis, "Performances and potential applications of erbium doped planar waveguide amplifiers and lasers," <i>GeeO</i> , pp. 58-63.
<i>me</i>	BELKIND et al., "Using pulsed direct current power for reactive sputtering of Al <sub>2</sub> O <sub>3</sub> ," <i>J. Vac. Sci. Technol. A</i> 17(4), pp. 1934-40 (Jul. 1999).
<i>me</i>	BYER et al., "Nonlinear Optics and Solid-state Lasers," <i>IEEE Journal on Selected Topics in Quantum Electronics</i> , Vol. 6, No. 6, pp. 921-929 (Nov. 2000).
<i>me</i>	FUJII et al., "1.54 mm photoluminescence of Er <sup>3+</sup> doped into SiO <sub>2</sub> films containing Si nanocrystals: Evidence for energy transfer from Si nanocrystals for Er <sup>3+</sup> ," <i>Appl. Phys. Lett.</i> , 71 (9), pp. 1198-1200 (September, 1997).
<i>me</i>	KELLY et al., "Reactive pulsed magnetron sputtering process for alumina films," <i>J. Vac. Sci. Technol. A</i> 18(6), pp. 2890-96 (Nov. 2000).
<i>me</i>	KELLY et al., "Control of the structure and properties of aluminum oxide coatings deposited by pulsed magnetron sputtering," <i>J. Vac. Sci. Technol. A</i> 17(3), pp. 945-953 (May 1999).
<i>me</i>	PAN et al., "Planar Er <sup>3+</sup> -doped aluminosilicate waveguide amplifier with more than 10 dB gain across C-band," <i>Optical Society of America</i> , 3 pages (2000).
<i>me</i>	ROBERTS et al., "The Photoluminescence of Erbium-doped Silicon Monoxide," <i>Department of Electronics and Computer Science</i> , 7 pages (June 1996).
<i>me</i>	SCHILLER et al. "PVD Coating of Plastic Webs and Sheets with High Rates on Large Areas," <i>European Materials Research Society 1999 Spring Meeting, Strasbourg, France (June 1-4, 1999)</i> .
<i>me</i>	SHAW et al. "Use of Vapor Deposited Acrlate Coatings to Improve the Barrier Properties of Metallized Film," <i>Society of Vacuum Coaters 505/856-7168, 37th Annual Technical Conference Proceedings</i> , pp. 240-244 (1994).
<i>me</i>	SHIN et al. "Dielectric and Electrical Properties of Sputter Grown (Ba,Sr)TiO <sub>3</sub> Thin Films," <i>J. Appl. Phys.</i> , Vol. 86, No. 1, pp. 506-513, (July 1, 1999).
<i>me</i>	SHMULOVICH et al., "Recent progress in Erbium-doped waveguide amplifiers," <i>Bell Laboratories</i> , 3 pages (1999).
<i>me</i>	TING et al., "Study of planarized sputter-deposited SiO <sub>2</sub> ," <i>J. Vac. Sci. Technol.</i> , 15(3) pp. 1105-1112 (May/Jun. 1978).

Examiner	<i>Michelle Estrada</i>	Date Considered	<i>9/28/04</i>
*Examiner:	Initial if reference considered, whether or not citation is in conformance with MPEP 609; draw line through citation if not in conformance and not considered. Include copy of this form with next communication to applicant.		
Form PTO 1449	Patent and Trademark Office - U.S. Department of Commerce		





OMB No. 0651-0011

INFORMATION DISCLOSURE CITATION

Atty. Docket No.	08140-0078	Appln. No.	10/101,863
Applicant	ZHANG et al.		
Filing Date	March 16, 2002	Group:	2823

U.S. PATENT DOCUMENTS						
Examiner Initial*	Document Number	Issue Date	Name	Class	Sub Class	Filing Date If Appropriate
<i>ME</i>	3,616,403	Oct. 26, 1971	Collins et al.	204	192	
<i>ME</i>	3,850,604	Nov. 26, 1974	Klein	65	32	
<i>ME</i>	4,111,523	Sep. 5, 1978	Kaminow et al.	350	96.14	
<i>ME</i>	4,619,680	Oct. 28, 1986	Nourshargh et al.	65	3.12	
<i>ME</i>	5,196,041	Mar. 23, 1993	Tumminelli et al.	65	30.1	
<i>ME</i>	5,287,427	Feb. 15, 1994	Atkins et al.	385	124	
<i>ME</i>	6,511,615 B1	Jan. 28, 2003	Dawes et al.	264	1.21	
<i>ME</i>	6,563,998 B1	May 13, 2003	Farah et al.	385	131	
<i>ME</i>	6,605,228 B1	Aug. 12, 2003	Kawaguchi et al.	216	24	
<i>ME</i>	6,615,614 B1	Sep. 9, 2003	Makikawa et al.	65	386	

FOREIGN PATENT DOCUMENTS						
Document Number	Publication Date	Country	Class	Sub Class	Translation Yes or No	

OTHER DOCUMENTS (Including Author, Title, Date, Pertinent Pages, Etc.)	

Examiner <i>Michelle Costada</i>	Date Considered <i>9/28/04</i>
*Examiner: Initial if reference considered, whether or not citation is in conformance with MPEP 609; draw line through citation if not in conformance and not considered. Include copy of this form with next communication to applicant.	
Form PTO 1449	Patent and Trademark Office - U.S. Department of Commerce







UNITED STATES PATENT AND TRADEMARK OFFICE

UNITED STATES DEPARTMENT OF COMMERCE  
United States Patent and Trademark Office  
Address: COMMISSIONER FOR PATENTS  
P.O. Box 1450  
Alexandria, Virginia 22313-1450  
www.uspto.gov

APPLICATION NO.	FILING DATE	FIRST NAMED INVENTOR	ATTORNEY DOCKET NO.	CONFIRMATION NO.
10/101,863	03/16/2002	Hongmei Zhang	M-12245 US	6938
7590	10/06/2004			
Skjerven Morrill Macpherson LLP Suite 700 250 Metro Drive San Jose, CA 95110			EXAMINER ESTRADA, MICHELLE	
			ART UNIT 2823	PAPER NUMBER

DATE MAILED: 10/06/2004

Please find below and/or attached an Office communication concerning this application or proceeding.

<b>Office Action Summary</b>	<b>Application No.</b> 10/101,863	<b>Applicant(s)</b> ZHANG ET AL.	
	<b>Examiner</b> Michelle Estrada	<b>Art Unit</b> 2823	<i>ME</i>

-- The MAILING DATE of this communication appears on the cover sheet with the correspondence address --

**Period for Reply**

A SHORTENED STATUTORY PERIOD FOR REPLY IS SET TO EXPIRE 3 MONTH(S) FROM THE MAILING DATE OF THIS COMMUNICATION.

- Extensions of time may be available under the provisions of 37 CFR 1.136(a). In no event, however, may a reply be timely filed after SIX (6) MONTHS from the mailing date of this communication.
- If the period for reply specified above is less than thirty (30) days, a reply within the statutory minimum of thirty (30) days will be considered timely.
- If NO period for reply is specified above, the maximum statutory period will apply and will expire SIX (6) MONTHS from the mailing date of this communication.
- Failure to reply within the set or extended period for reply will, by statute, cause the application to become ABANDONED (35 U.S.C. § 133). Any reply received by the Office later than three months after the mailing date of this communication, even if timely filed, may reduce any earned patent term adjustment. See 37 CFR 1.704(b).

**Status**

- 1)  Responsive to communication(s) filed on 23 July 2004.
- 2a)  This action is **FINAL**.                      2b)  This action is non-final.
- 3)  Since this application is in condition for allowance except for formal matters, prosecution as to the merits is closed in accordance with the practice under *Ex parte Quayle*, 1935 C.D. 11, 453 O.G. 213.

**Disposition of Claims**

- 4)  Claim(s) 1-14 and 20-24 is/are pending in the application.  
4a) Of the above claim(s) \_\_\_\_\_ is/are withdrawn from consideration.
- 5)  Claim(s) \_\_\_\_\_ is/are allowed.
- 6)  Claim(s) 1-13 and 20 is/are rejected.
- 7)  Claim(s) 7, 14 and 21-24 is/are objected to.
- 8)  Claim(s) \_\_\_\_\_ are subject to restriction and/or election requirement.

**Application Papers**

- 9)  The specification is objected to by the Examiner.
- 10)  The drawing(s) filed on \_\_\_\_\_ is/are: a)  accepted or b)  objected to by the Examiner.  
Applicant may not request that any objection to the drawing(s) be held in abeyance. See 37 CFR 1.85(a).  
Replacement drawing sheet(s) including the correction is required if the drawing(s) is objected to. See 37 CFR 1.121(d).
- 11)  The oath or declaration is objected to by the Examiner. Note the attached Office Action or form PTO-152.

**Priority under 35 U.S.C. § 119**

- 12)  Acknowledgment is made of a claim for foreign priority under 35 U.S.C. § 119(a)-(d) or (f).  
a)  All    b)  Some \* c)  None of:
1.  Certified copies of the priority documents have been received.
  2.  Certified copies of the priority documents have been received in Application No. \_\_\_\_\_.
  3.  Copies of the certified copies of the priority documents have been received in this National Stage application from the International Bureau (PCT Rule 17.2(a)).

\* See the attached detailed Office action for a list of the certified copies not received.

**Attachment(s)**

- |  |   |
|--|---|
| 1) <input type="checkbox"/> Notice of References Cited (PTO-892)   | 4) <input type="checkbox"/> Interview Summary (PTO-413)<br>Paper No(s)/Mail Date. _____ |
| 2) <input type="checkbox"/> Notice of Draftsperson's Patent Drawing Review (PTO-948)   | 5) <input type="checkbox"/> Notice of Informal Patent Application (PTO-152)             |
| 3) <input checked="" type="checkbox"/> Information Disclosure Statement(s) (PTO-1449 or PTO/SB/08)<br>Paper No(s)/Mail Date <u>7/23/04, 9/2/04</u> . | 6) <input type="checkbox"/> Other: _____  |

## DETAILED ACTION

### *Claim Objections*

Claim 14 is objected to because of the following informalities: in line 2, it appears that "12" should be deleted. Appropriate correction is required.

### *Claim Rejections - 35 USC § 103*

The following is a quotation of 35 U.S.C. 103(a) which forms the basis for all obviousness rejections set forth in this Office action:

(a) A patent may not be obtained though the invention is not identically disclosed or described as set forth in section 102 of this title, if the differences between the subject matter sought to be patented and the prior art are such that the subject matter as a whole would have been obvious at the time the invention was made to a person having ordinary skill in the art to which said subject matter pertains. Patentability shall not be negated by the manner in which the invention was made.

Claims 1-13 and 20 are rejected under 35 U.S.C. 103(a) as being unpatentable over the combination of Le et al. (2003/0077914) and Fukui et al. (5,755,938).

With respect to claim 1, Le et al. disclose providing pulsed DC power (22) to a target (14) (Page 4, Paragraph [0070]); providing bias power to a substrate (16) positioned opposite the target (Page 5, lines 13-14); providing process gas between the target and the substrate (Page 4, Paragraph [0067]).

With respect to claim 7, Le et al. disclose wherein the film is an upper cladding layer of a waveguide structure and the bias power is optimized to provide planarization Page 5, Paragraph [0075].

With respect to claim 8, Le et al. disclose wherein the process gas includes a mixture of oxygen and argon (Page 4, Paragraph [0067]).

With respect to claim 9, Le et al. disclose wherein the oxygen flow is adjusted to adjust the index of refraction of the film (Page 5, Paragraph [0076]).

With respect to claim 10, Le et al. disclose wherein the process gas further includes nitrogen (Page 5, Paragraph [0074]).

With respect to claim 11, Le et al. disclose wherein providing pulsed DC power to a target includes providing pulsed DC power to a target which has an area larger than that of the substrate (See fig. 3).

With respect to claim 12, Le et al. disclose further including uniformly sweeping the target with a magnetic field (Page 5, Paragraph [0073]).

With respect to claim 13, Le et al. disclose wherein uniformly sweeping the target with a magnetic field includes sweeping a magnet in one direction across the target where the magnet extends beyond the target in the opposite direction (Page 5, Paragraph [0073]).

With respect to claim 20, Le et al. disclose conditioning a target (Page 4, Paragraph [0070]); preparing the substrate (Page 3, Paragraph [0065]); adjusting the bias power to the substrate (Page 4, Paragraph [0041]); setting the process gas flow (Page 4, Paragraph [0067]); and applying pulsed DC power to the target to deposit the film (Page 4, Paragraph [0071]).

With respect to claims 2-4 and 6, One of ordinary skill in the art would have been led to the recited temperature, DC power, time pulse and bias power to routine experimentation to achieve a desire layer thickness, device dimension, device associated characteristics and device density on the finished wafer in view of the range

Art Unit: 2823

of values disclosed. Furthermore, Le et al. disclose that sets of process parameters depend on the specific process chamber (Page 6, Paragraph [0081]).

In addition, the selection of temperature, DC power, time pulse and bias power, its obvious because it is a matter of determining optimum process conditions by routine experimentation with a limited number of species of result effective variables. These claims are prima facie obvious without showing that the claimed ranges achieve unexpected results relative to the prior art range. In re Woodruff, 16 USPQ2d 1935, 1937 (Fed. Cir. 1990). See also In re Huang, 40 USPQ2d 1685, 1688 (Fed. Cir. 1996)(claimed ranges or a result effective variable, which do not overlap the prior art ranges, are unpatentable unless they produce a new and unexpected result which is different in kind and not merely in degree from the results of the prior art). See also In re Boesch, 205 USPQ 215 (CCPA) (discovery of optimum value of result effective variable in known process is ordinarily within skill or art) and In re Aller, 105 USPQ 233 (CCPA 1995) (selection of optimum ranges within prior art general conditions is obvious).

Note that the specification contains no disclosure of either the critical nature of the claimed temperature, DC power, time pulse and bias power or any unexpected results arising therefrom. Where patentability is said to be based upon particular chosen temperature, DC power, time pulse and bias power or upon another variable recited in a claim, the Applicant must show that the chosen temperature, DC power, time pulse and bias power are critical. In re Woodruff, 919 F.2d 1575, 1578, 16 USPQ2d 1934, 1936 (Fed. Cir. 1990).

Le et al. do not disclose providing a DC power through a filter.

With respect to claims 1 and 5, Fukui et al. disclose a sputtering process wherein the DC power supply (28) is connected through a band-pass filter.

It would have been within the scope of one of ordinary skill in the art to combine the teachings of Le et al. and Fukui et al. to enable the use of a DC power supply through a filter to be used in the process of Le et al. to adjust the impedance to have an infinite value so that no RF waves are superposed on a DC power from the DC power supply (Col. 6, lines 32-37).

#### ***Allowable Subject Matter***

Claims 7, 14 and 21-24 are objected to as being dependent upon a rejected base claim, but would be allowable if rewritten in independent form including all of the limitations of the base claim and any intervening claims.

#### ***Response to Arguments***

Applicant's arguments filed 7/23/04 have been fully considered but they are not persuasive. Applicant argues that Le et al. do not disclose a bias applied to the substrate. However, Applicant is directed to Page 5, lines 13-14, wherein Le et al. disclose applying a RF energy (bias) to the gas supplied to the substrate.

Applicant argues that Fukui does not teach a pulsed DC power supply. However, Fukui was not relied on upon for that purpose. Fukui teaches supplying power from a DC supply through a filter to the target. Fukui was relied on for the use of a filter to supply a power to the target.

In response to applicant's argument that the examiner's conclusion of obviousness is based upon improper hindsight reasoning, it must be recognized that any judgment on obviousness is in a sense necessarily a reconstruction based upon hindsight reasoning. But so long as it takes into account only knowledge which was within the level of ordinary skill at the time the claimed invention was made, and does not include knowledge gleaned only from the applicant's disclosure, such a reconstruction is proper. See *In re McLaughlin*, 443 F.2d 1392, 170 USPQ 209 (CCPA 1971).

Applicant argues that utilizing a filter provided for a DC power supply is not obvious and may not be necessary in the system taught by Le because of the lack of a bias. However, Le discloses applying a bias to energize the gas being applied to the substrate, as explained above. Therefore, a filter may be used to provide the pulsed DC power through the filter since a bias is being applied.

Applicant argues that there is no suggestion in Fukui that a pulsed DC power supply can be substituted for the RF power supply coupled to the target, nor would one skilled in the art be inclined to replace that RF power supply with a pulsed DC power supply. However, the Examiner is not substituting the pulsed DC power supply for the



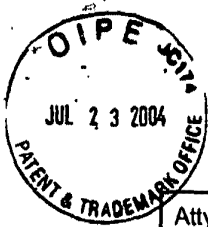
RF power supply coupled to the target. The rejection is based on utilizing the filter of Fukui to be used in the pulsed DC power supply of Le.

**THIS ACTION IS MADE FINAL.** Applicant is reminded of the extension of time policy as set forth in 37 CFR 1.136(a).

A shortened statutory period for reply to this final action is set to expire **THREE MONTHS** from the mailing date of this action. In the event a first reply is filed within **TWO MONTHS** of the mailing date of this final action and the advisory action is not mailed until after the end of the **THREE-MONTH** shortened statutory period, then the shortened statutory period will expire on the date the advisory action is mailed, and any extension fee pursuant to 37 CFR 1.136(a) will be calculated from the mailing date of the advisory action. In no event, however, will the statutory period for reply expire later than **SIX MONTHS** from the mailing date of this final action.

Any inquiry concerning this communication or earlier communications from the examiner should be directed to Michelle Estrada whose telephone number is 571-272-1858. The examiner can normally be reached on Monday through Friday.

If attempts to reach the examiner by telephone are unsuccessful, the examiner's supervisor, Olik Chaudhuri can be reached on 571-272-1855. The fax phone numbers for the organization where this application or proceeding is assigned are 703-308-7722 for regular communications and 703-308-7724 for After Final communications.



OMB No. 0651-0011

INFORMATION DISCLOSURE CITATION

Atty. Docket No.	09140-0016	Appln. No.	10/101,863
Applicant	ZHANG et al.		
Filing Date	March 16, 2002	Group:	2823

U.S. PATENT DOCUMENTS						
Examiner Initial*	Document Number	Issue Date	Name	Class	Sub Class	Filing Date If Appropriate
<i>ME</i>	2002/0106297		Ueno et al.	419	12	Aug. 08, 2002
<i>ME</i>	2003/0019326		Han et al.	45	245	Jan. 30, 2003
<i>ME</i>	2003/0063883		Demaray et al.	385	129	Apr. 3, 2003
<i>ME</i>	2003/0175142		Milonopoulou et al.	419	49	Sep. 18, 2003
<i>ME</i>	4,437,966	Mar. 7, 1961	Hope et al	204	298	
<i>ME</i>	4,915,810	Apr. 10, 1990	Kestigian et al.	204	298.04	
<i>ME</i>	4,978,437	Dec. 18, 1990	Wirz	204	192.	
<i>ME</i>	5,174,876	Dec. 29, 1992	Buchal et al.	427	526	
<i>ME</i>	5,200,029	Apr. 6, 1993	Bruce et al.	156	657	
<i>ME</i>	5,206,925	Apr. 27, 1993	Nakazawa et al.	385	142	
<i>ME</i>	5,225,288	Jul. 6, 1993	Beeson et al.	428	475.5	
<i>ME</i>	5,237,439	Aug. 17, 1993	Misono et al.	359	74	
<i>ME</i>	5,252,194	Oct. 12, 1993	Demaray et al.	204	298	
<i>ME</i>	5,303,319	Apr. 12, 1994	Ford et al.	385	131	
<i>ME</i>	5,381,262	Jan. 10, 1995	Arima et al.	359	341	
<i>ME</i>	5,427,669	Jun. 27, 1995	Drummond	204	298.2	
<i>ME</i>	5,475,528	Dec. 12, 1995	LaBorde	359	341	
<i>ME</i>	5,483,613	Jan. 9, 1996	Bruce et al.	385	129	
<i>ME</i>	5,555,127	Sep. 10, 1996	Abdelkader et al.	359	341	
<i>ME</i>	5,565,071	Oct. 15, 1996	Demaray et al.	204	192	
<i>ME</i>	5,603,816	Feb. 18, 1997	Demaray et al.	204	298	

Examiner <i>Michelle Estrade</i>	Date Considered <i>9/28/04</i>
*Examiner: Initial if reference considered, whether or not citation is in conformance with MPEP 609; draw line through citation if not in conformance and not considered. Include copy of this form with next communication to applicant.	
Form PTO 1449	Patent and Trademark Office - U.S. Department of Commerce



OMB No. 0651-0011

**INFORMATION DISCLOSURE CITATION**

Applicant	ZHANG et al.	Appln. No.	10/101,863
Filing Date	March 16, 2002	Group:	2823

**U.S. PATENT DOCUMENTS**

Examiner Initial*	Document Number	Issue Date	Name	Class	Sub Class	Filing Date If Appropriate
<i>ME</i>	5,613,995	Mar. 25, 1997	Bhandarkar et al.	65	384	
<i>ME</i>	5,654,054	Aug. 5, 1997	Tropsha et al.	428	36.6	
<i>ME</i>	5,693,956	Dec. 2, 1997	Shi et al.	257	40	
<i>ME</i>	5,718,813	Feb. 17, 1998	Drummond	204	192.2	
<i>ME</i>	5,719,976	Feb. 17, 1998	Henry et al.	385	50	
<i>ME</i>	5,792,550	Aug. 11, 1998	Phillips et al.	428	336	
<i>ME</i>	5,841,931	Nov. 24, 1998	Foresi et al.	385	131	
<i>ME</i>	5,847,865	Dec. 8, 1998	Gopinath et al.	359	343	
<i>ME</i>	5,855,744	Jan. 5, 1999	Halsey et al.	204	192	
<i>ME</i>	5,948,215	Sep. 7, 1999	Lantsman	204	192.12	
<i>ME</i>	5,961,682	Oct. 5, 1999	Lee et al.	65	384	
<i>ME</i>	5,977,582	Nov. 2, 1999	Fleming et al.	257	310	
<i>ME</i>	6,001,224	Dec. 14, 1999	Drummond	204	192.12	
<i>ME</i>	6,024,844	Feb. 15, 2000	Drummond et al.	204	192.12	
<i>ME</i>	6,051,114	Apr. 18, 2000	Yao et al.	204	192.3	
<i>ME</i>	6,093,944	Jul. 25, 2000	VanDover	257	310	
<i>ME</i>	6,162,709	Dec. 19, 2000	Raux et al.	438	513	
<i>ME</i>	6,176,986	Jan. 23, 2001	Watanabe et al.	204	298.13	
<i>ME</i>	6,248,291	Jun. 19, 2001	Nakagama et al.	419	46	
<i>ME</i>	6,280,585 B1	Aug. 28, 2001	Obinata et al.	204	298.19	
<i>ME</i>	6,287,986	Sep. 11, 2001	Mihara	438	763	

Examiner <i>Michelle Cotradu</i>	Date Considered <i>9/28/04</i>
*Examiner: Initial if reference considered, whether or not citation is in conformance with MPEP 609; draw line through citation if not in conformance and not considered. Include copy of this form with next communication to applicant.	
Form PTO 1449	Patent and Trademark Office - U.S. Department of Commerce



INFORMATION DISCLOSURE CITATION

Applicant	ZHANG et al.	Appln. No.	10/101,863
Patty. Docket No.	09140-0016		
Filing Date	March 16, 2002	Group:	2823

U.S. PATENT DOCUMENTS						
Examiner Initial*	Document Number	Issue Date	Name	Class	Sub Class	Filing Date If Appropriate
<i>ME</i>	6,290,822	Sep. 18, 2001	Fleming et al.	204	192.22	
<i>ME</i>	6,344,419	Feb. 5, 2002	Forster et al.	438	758	
<i>ME</i>	6,350,353	Feb. 26, 2002	Gopalraja et al.	204	192.3	
<i>ME</i>	6,358,810	Mar. 19, 2002	Dornfest et al.	438	396	
<i>ME</i>	6,409,965	Jun. 25, 2002	Nagate et al.	419	26	
<i>ME</i>	6,413,382	Jul. 2, 2002	Wang et al.	204	192.12	
<i>ME</i>	6,537,428	Mar. 25, 2003	Xiong et al.	204	192.13	
<i>ME</i>	6,602,338	Aug. 5, 2003	Chen et al.	252	301.4	

FOREIGN PATENT DOCUMENTS						
	Document Number	Publication Date	Country	Class	Sub Class	Translation Yes or No
<i>ME</i>	EP 0 820 088	01/21/98	Europe	H 01 J	37/34	
<i>ME</i>	EP 0 867 985 A1	09/01/98	Europe	H 01 S	3/06	
<i>ME</i>	JP 6-010127	01/18/94	Japan	C 23 C	14/35	Abstract
<i>ME</i>	JP 6-100333	12/04/94	Japan	C 03 C	21/00	Abstract
<i>ME</i>	WO 00/22742	04/01/00	PCT	H 04 B		
<i>ME</i>	WO 00/36665	06/22/00	PCT	H 01 L	51/20	
<i>ME</i>	WO 02/12932	02/14/02	PCT	H 01 S	3/16	
<i>ME</i>	WO 96/23085	08/01/96	PCT	C 23 C	14/34	
<i>ME</i>	WO 97/35044	09/25/97	PCT	C 23 C	14/40	

Examiner	<i>Michelle Estrada</i>	Date Considered	<i>9/25/04</i>
*Examiner:	Initial if reference considered, whether or not citation is in conformance with MPEP 609; draw line through citation if not in conformance and not considered. Include copy of this form with next communication to applicant.		
Form PTO 1449		Patent and Trademark Office - U.S. Department of Commerce	



OMB No. 0651-0011

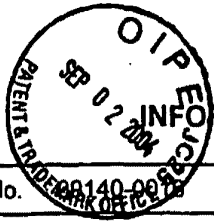
INFORMATION DISCLOSURE CITATION

Applicant	ZHANG et al.	Appln. No.	10/101,863
Filing Date	March 16, 2002	Group:	2823

OTHER DOCUMENTS (Including Author, Title, Date, Pertinent Pages, Etc.)	
<i>me</i>	BARBIER, Denis, "Performances and potential applications of erbium doped planar waveguide amplifiers and lasers," <i>GeeO</i> , pp. 58-63.
<i>me</i>	BELKIND et al., "Using pulsed direct current power for reactive sputtering of Al <sub>2</sub> O <sub>3</sub> ," <i>J. Vac. Sci. Technol. A</i> 17(4), pp. 1934-40 (Jul. 1999).
<i>me</i>	BYER et al., "Nonlinear Optics and Solid-state Lasers," <i>IEEE Journal on Selected Topics in Quantum Electronics</i> , Vol. 6, No. 6, pp. 921-929 (Nov. 2000).
<i>me</i>	FUJII et al., "1.54 mm photoluminescence of Er <sup>3+</sup> doped into SiO <sub>2</sub> films containing Si nanocrystals: Evidence for energy transfer from Si nanocrystals for Er <sup>3+</sup> ," <i>Appl. Phys. Lett.</i> , 71 (9), pp. 1198-1200 (September, 1997).
<i>me</i>	KELLY et al., "Reactive pulsed magnetron sputtering process for alumina films," <i>J. Vac. Sci. Technol. A</i> 18(6), pp. 2890-96 (Nov. 2000).
<i>me</i>	KELLY et al., "Control of the structure and properties of aluminum oxide coatings deposited by pulsed magnetron sputtering," <i>J. Vac. Sci. Technol. A</i> 17(3), pp. 945-953 (May 1999).
<i>me</i>	PAN et al., "Planar Er <sup>3+</sup> -doped aluminosilicate waveguide amplifier with more than 10 dB gain across C-band," <i>Optical Society of America</i> , 3 pages (2000).
<i>me</i>	ROBERTS et al., "The Photoluminescence of Erbium-doped Silicon Monoxide," <i>Department of Electronics and Computer Science</i> , 7 pages (June 1996).
<i>me</i>	SCHILLER et al. "PVD Coating of Plastic Webs and Sheets with High Rates on Large Areas," <i>European Materials Research Society 1999 Spring Meeting, Strasbourg, France</i> (June 1-4, 1999).
<i>me</i>	SHAW et al. "Use of Vapor Deposited Acrylate Coatings to Improve the Barrier Properties of Metallized Film," <i>Society of Vacuum Coaters 505/856-7168, 37th Annual Technical Conference Proceedings</i> , pp. 240-244 (1994).
<i>me</i>	SHIN et al. "Dielectric and Electrical Properties of Sputter Grown (Ba,Sr)TiO <sub>3</sub> Thin Films," <i>J. Appl. Phys.</i> , Vol. 86, No. 1, pp. 506-513, (July 1, 1999).
<i>me</i>	SHMULOVICH et al., "Recent progress in Erbium-doped waveguide amplifiers," <i>Bell Laboratories</i> , 3 pages (1999).
<i>me</i>	TING et al., "Study of planarized sputter-deposited SiO <sub>2</sub> ," <i>J. Vac. Sci. Technol.</i> , 15(3) pp. 1105-1112 (May/Jun. 1978).

Examiner	<i>Mitchell Estrada</i>	Date Considered	<i>9/28/04</i>
*Examiner:	Initial if reference considered, whether or not citation is in conformance with MPEP 609; draw line through citation if not in conformance and not considered. Include copy of this form with next communication to applicant.		
Form PTO 1449	Patent and Trademark Office - U.S. Department of Commerce		





OMB No. 0651-0011

INFORMATION DISCLOSURE CITATION

Atty. Docket No.	09140-009	Appln. No.	10/101,863
Applicant	ZHANG et al.		
Filing Date	March 16, 2002	Group:	2823

U.S. PATENT DOCUMENTS						
Examiner Initial*	Document Number	Issue Date	Name	Class	Sub Class	Filing Date If Appropriate
<i>ME</i>	3,616,403	Oct. 26, 1971	Collins et al.	204	192	
<i>ME</i>	3,850,604	Nov. 26, 1974	Klein	65	32	
<i>ME</i>	4,111,523	Sep. 5, 1978	Kaminow et al.	350	96.14	
<i>ME</i>	4,619,680	Oct. 28, 1986	Nourshargh et al.	65	3.12	
<i>ME</i>	5,196,041	Mar. 23, 1993	Tumminelli et al.	65	30.1	
<i>ME</i>	5,287,427	Feb. 15, 1994	Atkins et al.	385	124	
<i>ME</i>	6,511,615 B1	Jan. 28, 2003	Dawes et al.	264	1.21	
<i>ME</i>	6,563,998 B1	May 13, 2003	Farah et al.	385	131	
<i>ME</i>	6,605,228 B1	Aug. 12, 2003	Kawaguchi et al.	216	24	
<i>ME</i>	6,615,614 B1	Sep. 9, 2003	Makikawa et al.	65	386	

FOREIGN PATENT DOCUMENTS						
	Document Number	Publication Date	Country	Class	Sub Class	Translation Yes or No

OTHER DOCUMENTS (Including Author, Title, Date, Pertinent Pages, Etc.)	

Examiner <i>Mabelle Cotrude</i>	Date Considered <i>9/28/04</i>
*Examiner: Initial if reference considered, whether or not citation is in conformance with MPEP 609; draw line through citation if not in conformance and not considered. Include copy of this form with next communication to applicant.	
Form PTO 1449	Patent and Trademark Office - U.S. Department of Commerce

Application/Control Number: 10/101,863  
Art Unit: 2823

Page 8

Any inquiry of a general nature or relating to the status of this application or proceeding should be directed to the receptionist whose telephone number is 571-272-2800.



MEstrada  
October 4, 2004



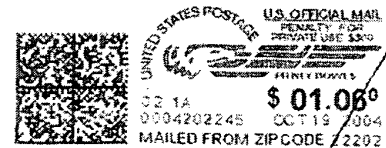
Gik Chanchuri  
Supervisory Patent Examiner,  
Technology Center 2800



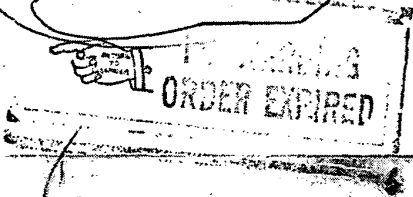
Organization TC2800 Bldg./Room Jeff

U. S. DEPARTMENT OF COMMERCE  
COMMISSIONER FOR PATENTS  
P.O. BOX 1450  
ALEXANDRIA, VA 22313-1450  
IF UNDELIVERABLE RETURN IN TEN DAYS

OFFICIAL BUSINESS



AN EQUAL OPPORTUNITY EMPLOYER



*[Handwritten signature]*

63

RECEIVED  
OCT 28 2004  
TECHNOLOGY CENTER 2800



61

175

175

2823

PATENT  
Customer No. 22,852  
Attorney Docket No. 09140-0016-00000

IN THE UNITED STATES PATENT AND TRADEMARK OFFICE

In re Application of:	)	
ZHANG et al.	)	Group Art Unit: 2823
Application No.: 10/101,863	)	Examiner: Michelle Estrada
Filed: March 16, 2002	)	Confirmation No.: 6938
For: BIASED PULSED DC REACTIVE SPUTTERING OF OXIDE FILMS	)	

Mail Stop AMENDMENTS  
Commissioner for Patents  
P.O. Box 1450  
Alexandria, VA 22313-1450

Sir:

**SECOND SUPPLEMENTAL INFORMATION DISCLOSURE**  
**STATEMENT UNDER 37 C.F.R. § 1.97(c)**

Pursuant to 37 C.F.R. §§ 1.56 and 1.97(c), Applicants bring to the attention of the Examiner the documents listed on the attached Form PTO/SB/08. This Information Disclosure Statement is being filed after the events recited in Section 1.97(b) but, to the undersigned's knowledge, before the mailing date of either a Final action, Quayle action, or a Notice of Allowance. Under the provisions of 37 C.F.R. § 1.97(c), this Information Disclosure Statement is accompanied by a fee of \$180.00 as specified by Section 1.17(p).

These documents, as summarized in the chart below, are U.S. patents and applications that are possibly related to the pending application by subject matter. This submission should not be construed, however, as an admission of relatedness.

12/08/2004 HDENESS1 00000109 10101863

01 FC:1806

180.00 DP

<b>Attorney Docket Number</b>	<b>U.S. Patent/ Serial No.</b>	<b>U.S./PCT Publication No.</b>	<b>Title</b>	<b>Examiner</b>
09140-0001-00	10/291,179	US 2003/0134054 A1	Low temperature zirconia based thermal barrier layer by PVD	Rodney McDONALD
09140-0002-01	6,506,289	US 2002/0033330 A1	Planar optical devices and methods for their manufacture	Steven H. VERSTEEG
09140-0002-02	6,827,826	US 2003/0127319 A1	Planar optical devices and methods for their manufacture	Steven H. VERSTEEG
09140-0004-00	6,533,907	US 2002/0134671 A1	Method of Producing amorphous silicon for hard mask and waveguide applications	Steven H. VERSTEEG
09140-0014-00	09/903,081	US 2003/0063883 A1	As-deposited planar optical waveguides with low scattering loss and methods for their manufacture	John M. HOFFMANN
09140-0015-00	10/101,492	US 2003/0173208 A1	Mode size converter for a planar waveguide	Steven H. VERSTEEG
09140-0016-00 (present application)	10/101,863	US 2003/0173207 A1	Biased pulse DC reactive sputtering of oxide films	Michelle ESTRADA
09140-0016-01	10/954,182		Biased pulse DC reactive sputtering of oxide films	Not Yet Assigned
09140-0017-00	10/101,341	US 2003/0175142 A1	Rare-earth pre-alloyed PVD targets for dielectric planar applications	Daniel J. JENKINS
09140-0021-00 (abandoned)	10/101,493	US 2003/0174391 A1	Gain flattened optical amplifier	Deandra M. HUGHES
09140-0025-00	10/650,461	US 2004/0105644 A1 WO 2004/021532 A1	Optical Coupling into Highly Uniform Waveguides	Scott A. KNAUSS
09140-0030-00	10/789,953	WO 2004/077519 A2	Dielectric Barrier Films	Not Yet Assigned

<b>Attorney Docket Number</b>	<b>U.S. Patent/ Serial No.</b>	<b>U.S./PCT Publication No.</b>	<b>Title</b>	<b>Examiner</b>
09140-0033-00	10/851,542		Energy Conversion and Storage Devices by Physical Vapor Deposition of Titanium and Titanium Oxides and Sub-Oxides	Not Yet Assigned
09140-0034-00	10/850,968		Transparent Conductive Oxides from a Metallic Target	Not Yet Assigned

U.S. Patent Application No. 10/954,182 (Attorney Docket No. 09140-0016-01) is a continuation of the present application and has the same specification.

For U.S. Patent Application No. 10/789,953 (Attorney Docket No. 09140-0030-00) the Applicants submit corresponding PCT publication.

For U.S. Patent Application No. 10/851,542 (Attorney Docket No. 09140-0033-00) and U.S. Patent Application No. 10/850,968 (Attorney Docket No. 09140-0034-00), that have not been published yet, the Applicants submit copies of specifications as filed.

The Applicants submit office actions issued by the U.S. Patent and Trademark Office in the above-listed applications.

The Applicants also submit International Search Reports and Written Opinions issued in the Patent Cooperation Treaty applications corresponding to the U.S. Patent Applications listed above.

Applicants respectfully request that the Examiner consider the listed documents and indicate that they were considered by making appropriate notations on the attached form. Should

the Examiner conclude that any of these claims form the basis of a rejection, the Examiner is invited to contact the undersigned.

This submission does not represent that a search has been made or that no better art exists and does not constitute an admission that each or all of the listed documents are material or constitute "prior art." If the Examiner applies any of the documents as prior art against any claim in the application and Applicants determine that the cited documents do not constitute "prior art" under United States law, Applicants reserve the right to present to the Office the relevant facts and law regarding the appropriate status of such documents.

Applicants further reserve the right to take appropriate action to establish the patentability of the disclosed invention over the listed documents, should one or more of the documents be applied against the claims of the present application.

If there is any additional fee due in connection with the filing of this Statement, please charge the fee to our Deposit Account No. 06-0916.

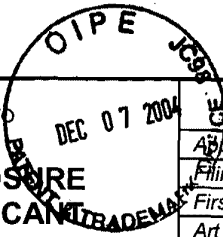
Respectfully submitted,

FINNEGAN, HENDERSON, FARABOW,  
GARRETT & DUNNER, L.L.P.

Dated: December 7, 2004

By: 

Gary J. Edwards  
Reg. No. 41,008



Complete if Known

**INFORMATION DISCLOSURE STATEMENT BY APPLICANT**

(Use as many sheets as necessary)

Application Number	10/101,863
Filing Date	March 16, 2002
First Named Inventor	ZHANG et al.
Art Unit	2823
Examiner Name	Michelle ESTRADA
Attorney Docket Number	09140-0016-00000

Sheet	1	of	2
-------	---	----	---

**U.S. PATENTS AND PUBLISHED U.S. PATENT APPLICATIONS**

Examiner Initials	Cite No. <sup>1</sup>	Document Number	Issue or Publication Date MM-DD-YYYY	Name of Patentee or Applicant of Cited Document	Pages, Columns, Lines, Where Relevant Passages or Relevant Figures Appear
		Number-Kind Code <sup>2</sup> (if known)			
		US 2002/0033330 A1	Mar. 21, 2002	Demaray et al.	
		US 2002/0134671 A1	Jul. 17, 2003	Demaray et al.	
		US 2003/0063883 A1	Apr. 3, 2003	Demaray et al.	
		US 2003/0127319 A1	Jul. 10, 2003	Demaray et al.	
		US 2003/0134054 A1	Jul. 17, 2003	Demaray et al.	
		US 2003/0173207 A1	Sep. 18, 2003	Zhang et al.	
		US 2003/0173208 A1	Sep. 18, 2003	Pan et al.	
		US 2003/0174391 A1	Sep. 18, 2003	Pan et al.	
		US 2003/0175142 A1	Sep. 18, 2003	Milonopoulou et al.	
		US 2004/0105644 A1	Jun. 3, 2004	Dawes	
		US 6,506,289	Jan. 14, 2003	Demaray et al.	
		US 6,533,907	Mar. 18, 2003	Demaray et al.	
		US 6,827,826	Dec. 7, 2004	Demaray et al.	

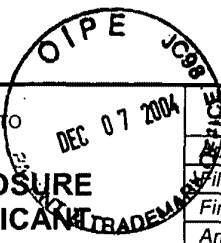
**Note: Copies of the U.S. Patent Documents are not Required in IDS filed after October 21, 2004**

**FOREIGN PATENT DOCUMENTS**

Examiner Initials	Cite No. <sup>1</sup>	Foreign Patent Document	Publication Date MM-DD-YYYY	Name of Patentee or Applicant of Cited Document	Pages, Columns, Lines, Where Relevant Passages or Relevant Figures Appear	Translation <sup>6</sup>
		Country Code <sup>3</sup> Number <sup>4</sup> Kind Code <sup>5</sup> (if known)				
		WO 2004/021532 A1	Mar. 11, 2004	Symmorphix, Inc.		
		WO 2004/077519 A2	Sep. 10, 2004	Narasimhan et al.		

Examiner Signature		Date Considered	
--------------------	--	-----------------	--

EXAMINER: Initial if reference considered, whether or not citation is in conformance with MPEP 609. Draw line through citation if not in conformance and not considered. Include copy of this form with next communication to applicant.



IDS Form PTO/SB/08: Substitute for form 1449A/PTO				<b>Complete if Known</b>	
<b>INFORMATION DISCLOSURE STATEMENT BY APPLICANT</b> <i>(Use as many sheets as necessary)</i>				Application Number	10/101,863
				Filing Date	March 16, 2002
				First Named Inventor	ZHANG et al.
				Art Unit	2823
				Examiner Name	Michelle ESTRADA
				Attorney Docket Number	09140-0016-00000
Sheet	2	of	2		

NON PATENT LITERATURE DOCUMENTS			
Examiner Initials <sup>7</sup>	Cite No. <sup>1</sup>	Include name of the author (in CAPITAL LETTERS), title of the article (when appropriate), title of the item (book, magazine, journal, serial, symposium, catalog, etc.), date, page(s), volume-issue number(s), publisher, city and/or country where published.	Translation <sup>8</sup>
		Office Action issued on September 27, 2004 in U.S. Serial No. 10/291,179 (Attorney Docket No. 09140-0001-00).	
		Office Action issued on November 28, 2001 in U.S. Patent No. 6,506,289 (Attorney Docket No. 09140-0002-01).	
		Office Action issued on April 17, 2002 in U.S. Patent No. 6,506,289 (Attorney Docket No. 09140-0002-01).	
		Quayle Action issued on November 10, 2003 in U.S. Patent No. 6,827,826 (Attorney Docket No. 09140-0002-02).	
		Office Action issued on May 2, 2002 in U.S. Patent No. 6,533,907 (Attorney Docket No. 09140-0004-00).	
		Office Action issued on February 12, 2004 in U.S. Serial No. 09/903,081 (Attorney Docket No. 09140-0014-00).	
		Office Action issued on September 10, 2004 in U.S. Serial No. 09/903,081 (Attorney Docket No. 09140-0014-00).	
		Office Action issued on September 3, 2003 in U.S. Serial No. 10/101,492 (Attorney Docket No. 09140-0015-00).	
		Office Action issued on October 22, 2003 in U.S. Serial No. 10/101,341 (Attorney Docket No. 09140-0017-00).	
		Office Action issued on June 10, 2004 in U.S. Serial No. 10/101,341 (Attorney Docket No. 09140-0017-00).	
		Office Action issued on May 4, 2004 in U.S. Serial No. 10/101,493 (Attorney Docket No. 09140-0021-00).	
		International Search Report issued on November 21, 2003 in PCT/US03/24809 (Attorney Docket No. 09140-0025-00).	
		International Search Report issued on October 11, 2004 in PCT/US2004/005531 (Attorney Docket No. 09140-0030-00)	
		Written Opinion issued on October 11, 2004 in PCT/US2004/005531 (Attorney Docket No. 09140-0030-00)	
		Patent Application No. 10/851,542 for ENERGY CONVERSION AND STORAGE DEVICES BY PHYSICAL VAPOR DEPOSITION OF TITANIUM AND TITANIUM OXIDES AND SUB-OXIDES filed on May 20, 2004. (Attorney Docket No. 09140-0033-00)	
		Patent Application No. 10/850,968 for TRANSPARENT CONDUCTIVE OXIDES FROM A METALLIC TARGET filed on May 20, 2004. (Attorney Docket No. 09140-0034-00)	

Examiner Signature	Date Considered
--------------------	-----------------

EXAMINER: Initial if reference considered, whether or not citation is in conformance with MPEP 609. Draw line through citation if not in conformance and not considered. Include copy of this form with next communication to applicant.

(12) INTERNATIONAL APPLICATION PUBLISHED UNDER THE PATENT COOPERATION TREATY (PCT)

(19) World Intellectual Property Organization  
International Bureau



(43) International Publication Date  
11 March 2004 (11.03.2004)

PCT

(10) International Publication Number  
WO 2004/021532 A1

(51) International Patent Classification?: H01S 3/16,  
3/063, 3/0933

[US/US]; 5861 Castleknock Road, Dublin, OH 43016, (US).

(21) International Application Number:  
PCT/US2003/024809

(74) Agent: GARRETT, Arthur, S.; Finnegan, Henderson, Farabow, Garrett & Dunner L.L.P., 1300 I Street, N.W., Washington, DC 20005-3315 (US).

(22) International Filing Date: 27 August 2003 (27.08.2003)

(25) Filing Language: English

(26) Publication Language: English

(30) Priority Data:  
60/406,451 27 August 2002 (27.08.2002) US

(81) Designated States (national): AE, AG, AL, AM, AT, AU, AZ, BA, BB, BG, BR, BY, BZ, CA, CH, CN, CO, CR, CU, CZ, DE, DK, DM, DZ, EC, EE, ES, FI, GB, GD, GE, GH, GM, HR, HU, ID, IL, IN, IS, JP, KE, KG, KP, KR, KZ, LC, LK, LR, LS, LT, LU, LV, MA, MD, MG, MK, MN, MW, MX, MZ, NI, NO, NZ, OM, PG, PH, PL, PT, RO, RU, SC, SD, SE, SG, SK, SL, SY, TJ, TM, TN, TR, TT, TZ, UA, UG, US, UZ, VC, VN, YU, ZA, ZM, ZW.

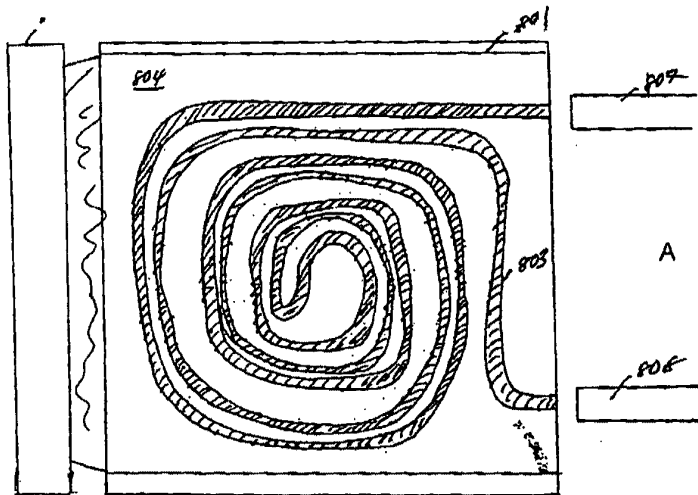
(71) Applicant (for all designated States except US): SYM-MORPHIX, INC. [US/US]; 1278 Reamwood Avenue, Sunnyvale, CA 94089-2233 (US).

(84) Designated States (regional): ARIPO patent (GH, GM, KE, LS, MW, MZ, SD, SL, SZ, TZ, UG, ZM, ZW), Eurasian patent (AM, AZ, BY, KG, KZ, MD, RU, TJ, TM), European patent (AT, BE, BG, CH, CY, CZ, DE, DK, EE, ES, FI, FR, GB, GR, HU, IE, IT, LU, MC, NL, PT, RO,

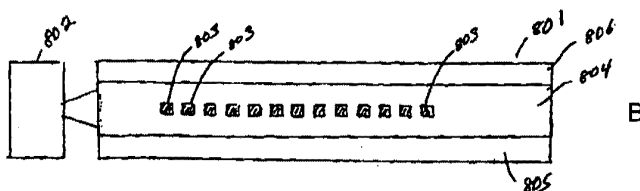
(72) Inventor; and  
(75) Inventor/Applicant (for US only): DAWES, David.

[Continued on next page]

(54) Title: OPTICALLY COUPLING INTO HIGHLY UNIFORM WAVEGUIDES



(57) Abstract: In accordance with the present invention, one or more laser diodes (802) are efficiently coupled into a waveguide amplifier (801) in order to provide either an efficient amplifier or a laser. Light from one or more laser diodes (802) is efficiently coupled into one or more waveguides (803) through the effects in the refractive index between the core material of the waveguide and the cladding material (804) around the waveguide. Both the core material (803) and the cladding material (804) can be deposited with a high degree of uniformity and control in order to obtain the coupling.



WO 2004/021532 A1

BEST AVAILABLE COPY





SE, SI, SK, TR), OAPI patent (BF, BJ, CF, CG, CI, CM, GA, GN, GQ, GW, ML, MR, NE, SN, TD, TG).

*For two-letter codes and other abbreviations, refer to the "Guidance Notes on Codes and Abbreviations" appearing at the beginning of each regular issue of the PCT Gazette.*

**Published:**

— *with international search report*

## OPTICALLY COUPLING INTO HIGHLY UNIFORM WAVEGUIDES

**Background****1. Technical Area**

[0001] The present invention relates to coupling of pump light into an optical amplifier or a laser and, in particular, to coupling from a multimode laser diode in order to optically pump an optical amplifier or laser.

**2. Discussion of Related Art**

[0002] Use of directed energy beams, such as those produced by amplifiers or lasers, are diverse and include applications in a wide range of fields, including biotechnology, medicine, semiconductor processing, manufacturing, image recording and defense. In biotechnology, directed energy beams are used, for example, in flow cytometry, DNA sequencing, confocal microscopy, and hematology. Medical applications include use in ophthalmology, non-invasive surgery, and photodynamic therapy. In the semiconductor industry, applications include wafer inspection, rapid thermal processing, and scribing or marking. Image recording applications include, for example, high-speed printing, photo-processing, film subtitling and holography. Industrial applications include, for example, rapid prototyping, materials processing and scribing or marking. Additionally, military applications include range finding, target designation, lidar, and chemical or biological threat detection. The graphics and printing industry, one of the largest businesses in the world, has a need for inexpensive laser systems for use in applications such as thermal graphics. Such applications require a highly reliable, low noise laser or optical amplifier at a low cost.

[0003] Typically, applications for directed energy beams require a laser or optical amplifier. An optical amplifier differs from a laser by the absence of a laser cavity. Both devices typically require an active optical material, for example rare-earth doped YAG, ruby ( $\text{Al}_2\text{O}_3:\text{Cr}$ ), or other material, which can be optically "pumped," such that energy can be stored in the excited states of the active atoms or molecules by an optical pump source. Amplification of input optical radiation or stimulated emission for lasing then occurs when the same optical energy stored in

the excited states is coupled to the incident optical beam.

[0004] Figure 1A shows an example of a side-pumped laser 100. Laser material 101 is positioned in a laser cavity defined by mirrors 102 and 103 and is pumped by diode array 104. Diode array 104 includes a series of laser diodes 105-1 through 105-N positioned to illuminate all or most of laser material 101. There are a variety of choices for laser diodes and laser diode arrays available to pump Nd or Yb doped YAG, for example. In most applications, Nd:YAG is pumped at about 808 nm and Yb:YAG is pumped at about 940 nm. Choices for diode array 104 include 10-40W arrays, 40-50W single bars, and 240-600W stacked bars, for example. Arrays can also be formed from readily available 1-2W single laser diodes.

[0005] Figure 1B illustrates the optical density in a cross section of laser material 101 in side-pumped laser 100 of Figure 1A. As is shown in Figure 1B, the optical density is greatest in the center of laser material 101 where the laser beam is located. However, much of the pump energy is dissipated in areas of laser material 101 that are not actively involved in the lasing process. Therefore, side pumping techniques are inherently inefficient.

[0006] As is illustrated in Figure 1A, the laser beam is directed between mirrors 102 and 103, where a percentage of the beam is transmitted through mirror 103. Figure 2 illustrates the shape of a laser beam in a laser cavity such as in laser 100. The closer the laser beam is to its diffraction limit in laser material 101, the greater the depth of field and the smaller the diameter of beam handling optics (for example mirrors 102 and 103) required to transmit the beam. The ratio of the divergence of the laser beam to that of a theoretically diffraction limited beam of the same waist size in the TEM<sub>00</sub> mode is usually given as  $M^2 = (\Theta/\theta)$ , where  $\Theta$  is the divergence angle of the laser beam and  $\theta$  is the divergence angle of the theoretical laser beam. The angular size of the laser beam in the far field will be  $M^2$  times the size calculated for a perfect Gaussian beam, i.e.  $\Theta = M^2(2\lambda/W_0)$  for a beam waist diameter of  $2W_0$ .

[0007] Figure 1C illustrates an end-pumping arrangement for pumping laser material 101. In the arrangement shown in Figure 1C, laser material 101 is again placed in a laser cavity formed by mirrors 102 and 103. The laser optical energy transmitted through mirror 103 is reflected by a dichroic beam splitter 114 to form the beam. Optical energy from pump source 116 is incident on lens 115 and passes through dichroic beam splitter 114 and mirror 103 to focus in a nearly diffraction limited region of laser material 101. The beam from pump source 116 is reduced to a size and shape that resembles the shape of the laser beam shown in Figure 2

in active material 101. Additionally, a second pump source 110 can be focused by lens 113 through mirror 102 and into laser material 101. In some embodiments, additional optical energy can be coupled into laser material 101 from pump source 111 using a polarizing beam splitting cube 112, which transmits light from pump source 110 while reflecting light from pump source 111.

[0008] A cross section of laser material 101 illustrating optical power concentration is shown in Figure 1D. As can be seen in Figure 1D, nearly all of the pump power, as well as the laser beam, is focused in the active region of laser material 101, where the laser beam produced by laser 117 is produced.

[0009] As is pointed out in U.S. Patent 4,710,940 to D. L. Sipes, Jr, issued on December 1, 1987, to a first approximation, and not being limited by theory, the higher the pump power density the more efficient is the use of pump power. This concept is illustrated in the graphs shown in Figures 1E and 1F. Figure 1E shows the photon conversion efficiency (i.e., the number of pump photons versus the number of output laser light photons) with increasing mirror reflectivity at various input optical power densities. Higher mirror reflectivity increases the optical power density within the laser cavity. At higher pump power densities, higher efficiencies result. Figure 1F shows photon conversion efficiencies as a function of pump power for various spot sizes, which shows the same trend of higher efficiency with optical density as does the graph shown in Figure 1E. Spot size refers to the diameter of the optical pump in the optically active laser material.

[0010] Table I shows typical power usage and lifetime characteristics for a side pumped laser 100 as shown in Figure 1A, an end-pumped laser 117 as is shown in Figure 1C, and a lamp pumped laser. As expected, the diode end-pumped laser 117 has the greater efficiency. However, end-pumped laser systems have more optical components and therefore are difficult to align.

[0011] Typically, the optical beam from a laser diode outputs is highly asymmetric. Therefore, light from the diodes is difficult to couple into the active material, e.g. laser material 101, of an optical amplifier or a laser. However, as shown in Table I, the lifetimes, efficiency, and expense of various laser diode configurations make them very attractive as pump sources for optically active devices.

Table I

	Lamp Pumped	Diode End-Pumped	Diode Side-Pumped
Power to Pump Source	5000W	2.5W	50W
Power to Cooling System	500W	2.5 W	50W
Power from Pump Source	3500W	1.25W	20W
Single-Mode Power from Laser	10W	0.8W	10W
Wall-Plug Efficiency	0.2%	16%	10%
Cooling	Water	Free Air	Forced Air
Power Consumed/Output kW-hr	500 kW-hr	6.5 kW-hr	10 kW-hr
Cost of Light Source	\$200	\$400	\$1000
Lifetime of Light Source	200 hrs	20,000 hrs	10,000 hrs

[0012] Multimode laser diodes are highly desirable optical pump sources as they are inexpensive to manufacture and are capable of producing much higher power levels than single mode lasers. Multimode lasers are more reliable than single-mode lasers as they have lower output power densities reducing the risk of catastrophic facet damage, the primary cause of laser diode failure. However the light emitted by a multimode laser diode is very asymmetric. Typically, the laser diode emitting aperture has dimensions on the order of  $1\mu\text{m} \times 100\mu\text{m}$ . It is very difficult and costly to collect and couple light emitted by a multimode laser diode into the end facet of a single-mode optical waveguide or fiber.

[0013] Most conventional waveguide amplifiers and lasers include one or more waveguide cores doped with active elements, such as Er, Yb, Nd and Tm, and are designed such that the waveguide can support coaxially propagating single-mode output and pump light. The output power of a single-mode, single laser pumped amplifier or laser is often limited to about 20dBm (100mW) by the power levels of available single-mode pump lasers. Single-mode pump lasers require more precision manufacturing tolerances and are consequently more expensive to produce than multimode lasers. As a result complex and costly schemes are required to pump arrays of waveguide optical amplifiers and lasers. Pump light has to be distributed to each amplifier channel or laser element, requiring combinations of splitters, combiners, taps, monitors

and associated control electronics to effectively manage the distribution. Polarization sensitivity of waveguide elements further complicates the distribution process.

[0014] Therefore, there is a need for optical laser devices capable of efficiently coupling light from a laser diode into the active region of a laser cavity that is cost effective and reliable, and that produces high optical output power.

### Summary

[0015] In accordance with the present invention, an optical waveguide device that couples light from at least one laser diode into a high refractive index contrast slab waveguide is presented. In some embodiments, the high refractive index contrast slab waveguide includes a light duct in a horizontal plane in order to receive light from the at least one laser diode. In some embodiments, the high refractive index contrast slab waveguide includes a high refractive index active waveguide and an intermediate refractive index passive cladding.

[0016] In some embodiments, the high refractive index contrast slab waveguide is folded in a horizontal axis. In some embodiments, the intermediate passive cladding is thick enough in the vertical axis to capture a substantial amount of light from the at least one laser diode in the vertical direction. In some embodiments, light transmitted from the optical waveguide device is efficiently coupled into single mode optical fibers by mode size converters.

[0017] These and other aspects of the present invention are further described in the following figures.

### Short Description of the Figures

- [0018] Figures 1A and 1B illustrate a side-pumped solid-state laser.
- [0019] Figures 1C and 1D illustrate an end-pumped solid-state laser.
- [0020] Figures 1E and 1F show graphs illustrating higher pump efficiency with higher optical densities.
- [0021] Figure 2 illustrates the characteristics of a typical laser beam in a laser cavity.
- [0022] Figures 3A and 3B illustrate integration of photodetectors and laser diodes with planar waveguides.
- [0023] Figure 4 illustrates a butt-coupling technique for optically coupling between a laser diode and a waveguide.
- [0024] Figures 5A, 5B and 5C illustrate integrated coupling chips for coupling optical energy from a single mode laser diode chip.
- [0025] Figures 6A and 6B illustrate a coupling chip for coupling optical energy from a multi-mode laser diode array to a multi-mode optical fiber in accordance with the present invention.
- [0026] Figures 7A and 7B illustrate a coupling chip for coupling optical energy from a multi-mode laser diode array to a single mode optical fiber in accordance with the present invention.
- [0027] Figures 8A and 8B illustrate an embodiment of an amplifier chip according to the present invention.
- [0028] Figure 9 illustrates the optical materials utilized in waveguides according to the present invention.
- [0029] Figures 10A, 10B, and 10C illustrate an efficient mode size conversion for vertical

pumping of an amplifier core.

[0030] **Figure 11** illustrates a monolithic array beam concentrator chip according to the present invention.

[0031] **Figures 12A and 12B** illustrate the mode images for two example waveguides according to the present invention.

[0032] **Figure 13** illustrates a Vertical Cavity Surface Emitting Laser (VCSEL) pumped microchip laser according to the present invention.

### Detailed Description

[0033] Lasers and other light sources have great utility when able to produce high optical power densities. The speed and effectiveness of the interaction of laser power or energy with materials is in direct proportion to the brightness and intensity of the power or energy that the laser can deliver to the material. The highest brightness or intensity of a laser output beam is obtained when the beam is confined to the fundamental, lowest order transverse electromagnetic mode ( $TEM_{00}$ ). Therefore, single transverse mode is the highest brightness form of a laser's output, which is the laser's most desirable property.

[0034] In accordance with some embodiments of the present invention, a high refractive index contrast multimode slab waveguide of an appropriate design to collect and contain a high proportion of the light emitted by a single or multi-element multi-mode pump laser diode and efficiently couple that light into an assembly of actively doped single-mode waveguides embedded within the slab is presented. The light from the pump source, then, is efficiently coupled into one or more active regions through the effects of the differences in refractive index between the slab material of the waveguide and the cladding material around the slab. Both the slab material and the cladding material can be deposited with a high degree of uniformity and control in order to obtain the coupling. Further, the embedded active core material of the waveguide can also be manufactured with a high degree of uniformity and control.

[0035] In some embodiments of the invention, long, single-mode waveguides are folded many times to accommodate lengths greater than the dimensions of the pumped, encapsulating



multimode slab waveguide. The single-mode waveguide cores can be folded in such a manner as to optimize the effective absorption cross-section they present to the guided multimode pump light flux while minimizing losses due to bending experienced by propagating single-mode signal light. The efficiency of absorption of pump light from the multimode laser diodes by single-mode actively doped waveguide cores is a function of the ratio of the effective cross-section areas of the single-mode and multimode waveguides.

[0036] In some embodiments of the invention, the multimode slab waveguide itself is pumped. This effect can result in a slab light source.

[0037] In some embodiments, the dimension of the multimode slab waveguide enables conservation of high power densities of the light emitted by the pump laser diode elements, while not increasing the difficulty and reducing the effectiveness of direct coupling between the laser diodes and the edge facet of the slab waveguide. High pump power densities are particularly important for three-level active systems where natural ground state absorption must first be bleached out before gain can be achieved.

[0038] In some embodiments single-mode light emitted by the laser diode in its fast axis direction (i.e., the direction of larger laser beam divergence) is converted to multiple-mode light immediately after the light enters a slab waveguide, thereby limiting the return path for pump energy to the pump laser source. Such an arrangement increases the pumping efficiency because more light is available for pumping.

[0039] Lasing and optical amplification processes are processes of energy conversion. Energy is pumped into exciting active elements in the active material, where the energy is stored, from any energy source, commonly optical, which is capable of exciting the active elements. Energy stored in the excited active elements, then, is released when the excited active element is induced by a signal, such as when the active element is perturbed by presence of another photon, into releasing the energy in the form of an optical photon. For example, energy from the excited states of a laser material is released in a highly coherent form by stimulated emission. The efficiency of the conversion process is a key factor in determining the cost-effectiveness of a particular laser or optical amplification or conversion process.

[0040] Planar waveguide forms of optical amplifiers and lasers are desirable as they are very compact compared to other forms of optical amplifiers and lasers. In addition, a planar

waveguide form potentially allows the integration of diverse optical and electronic functions on, for example, silicon wafers which can be manufactured in high volumes and at low cost with processes commonly used in the semiconductor-industry. In addition to waveguides, slab emitters are desirable as efficient light sources.

[0041] **Figure 3A**, for example, illustrates integration of an optical waveguide 301 with a photodetector (PD) 302. Photodetector 302 is formed on semiconducting layer 305. An optical layer 303 is formed over photodiode 302 and waveguide 301 is formed on optical layer 303. Light traveling through waveguide 301 can be coupled onto photodetector 302 at coupler 306.

[0042] **Figure 3B** illustrates integration of pump laser diodes 310 with an active material waveguide 311. As shown in **Figure 3B**, laser waveguide 311 is formed on an optical layer 313. Optical layer 313 is formed over laser diodes 310, which are formed on semiconducting layer 312. In some embodiments, laser diodes 310 can be formed to the side of optical waveguide 311, over optical waveguide 311, or in any other orientation with respect to optical waveguide 311 that allows pumping of the active dopant ions of optical waveguide 311.

[0043] **Figure 4** illustrates coupling of a laser diode chip 410 with a high refractive index contrast ( $\Delta n$ ) waveguide 411. The method of coupling illustrated in **Figure 4** is referred to as "butt coupling," where laser diode 410 is a single-mode semiconductor laser diode output facet positioned to within about 5  $\mu\text{m}$  of high  $\Delta n$  rectangular waveguide 411 in order to correct for mode astigmatism, thereby reducing coupling loss. In some embodiments, about a 50% coupling can be achieved with this method utilizing uncoated facets. Unfortunately, customer demand is for greater than 80-85% coupling efficiency for laser diodes with complex, non-gaussian mode output profiles. Therefore, conventional butt-coupling techniques are not meeting customer demand.

[0044] **Figure 5A** illustrates a laser coupling chip 501 that couples light from a laser diode 506 to an optical fiber 507. Coupling chip 501 includes a waveguide 502 with an integrated photodiode 503 to allow for down-stream power monitoring. In some embodiments, photodiode 503 may couple about 0.02 dB to about 0.05 dB of the optical power in waveguide 502 to provide optical coupling. A dual-core mode size converter 504 can be formed in coupling chip 501 to optimize for efficient optical coupling to optical fiber 507. Dual-core mode size converter 504 can couple light to optical fiber with a coupling loss of about 0.25 dB. The resulting total loss of less than 1 dB in laser coupling chip 501 results in a greater than 80% coupling efficiency

between laser diode 506 and optical fiber 507. However, there remains the problem that the coupling efficiency between laser diode 506 and coupling chip 501 is less than 80%.

[0045] In some embodiments, coupling chip 501 can be formed on a millimeter-scale chip sized to fit a standard 14-pin butterfly package. Further, in order to achieve optimum coupling efficiencies, the slow-axis and fast-axis alignment between laser diode 506 and coupling chip 501 requires sub-micron positioning precision.

[0046] **Figure 5B** shows a single mode laser diode array coupler chip 508. Light from laser diode array 520 is coupled into waveguides 521, 522, 523, and 524. Waveguides 521, 522, 523 and 524 are each integrated with a photodetector 525, 526, 527, and 528, respectively, as is discussed above with regard to **Figure 5A**. Further, mode size converters 529, 530, 531, and 532 formed in waveguides 521, 522, 523, and 524, respectively, efficiently couple light into optical fibers 533, 534, 535, and 536, respectively. Light from diode array 520, then, is coupled through optical fibers 521, 522, 523, and 524 into optical fibers 533, 534, 535, and 536. **Figure 5C** shows a single mode laser diode array coupler chip 509 similar to diode array coupler chip 508 with a pitch size converter 540, which provides for closer packing of optical fibers 533, 534, 535, and 536.

[0047] Other pumping schemes are described, for example, in U.S. Patent 6,236,793, issued to Lawrence et al. on May 22, 2001; U.S. Patent 4,710,940, issued to Sipes; U.S. Patent 4,785,459 issued to Baer on November 15, 1988; and at Lawrence Livermore National Labs. In a system proposed by Lawrence, et al., the pump light is reflected into the active waveguide core by reflecting the pump beam from a prism. Signal power is then transmitted through the prism into the waveguide core. However, in this configuration alignment of the optics directing the pump power into the waveguide core for efficient pumping needs to be arranged such that the waist of the beam is incident on the waveguide core. This results in a large alignment problem for efficiently coupling the pump power into the waveguide core. The arrangement proposed by Sipes involves an array of laser diodes arranged along the corners of a pumping path, for example a zig-zag pattern, such that pump power from multiple laser diodes are coupled into an active waveguide. The arrangement proposed by Baer includes a side pumped active material block with zig-zagging of the signal beam, through the active material for maximum interaction.

[0048] Lawrence Livermore National Labs has proposed a high output Yb:YAG laser system that utilizes a diode bar stack and a lens duct that brings the pump light from the diode bar stack

into a Yb:YAG laser rod. About an 80% coupling efficiency can be achieved in this fashion. However, this solution requires a bulk laser rod and a large lens duct to direct light from the diode bar stack into the laser rod.

[0049] Some embodiments of the present invention can utilize multimode laser diodes in the form of single elements or arrays, to efficiently pump compact, single-mode, planar waveguide optical amplifiers, lasers, and slab devices, which can be integrated with other optical and electronic functions and manufactured inexpensively in high volumes with semiconductor industry techniques. As shown in **Figures 6A and 6B**, the output light from a multimode laser diode 610 is single-mode in the vertical plane (the fast axis) and multimode in the horizontal plane (the slow axis). Therefore, the output beam diverges very rapidly in the vertical axis (the fast axis) but slowly diverges in the horizontal plane (the slow axis).

[0050] **Figures 6A and 6B** illustrate coupling of light from a laser diode array into a planar waveguide in accordance with the present invention. As shown in **Figures 6A and 6B**, the light beam from multimode laser diode array 610 diverges less in the slow axis direction (shown in **Figure 6A**) than it does in the fast axis direction (shown in **Figure 6B**). The output beams from laser diode array 610 diverge more in the vertical axis (shown in **Figure 6B**) than in the horizontal axis (shown in **Figure 6A**). Embodiments of the present invention take advantage of the slow divergence in the horizontal axis to increase the optical density in high refractive index waveguide 612. Coupling chip 611 can include a large lens duct 613 to direct light into high refractive index waveguide 612. The material of waveguide 612 and lens duct 613 can be the same material and can be deposited and patterned on a substrate in the same series of processing steps. Light from waveguide 612 can then be coupled into multimode fiber 614.

[0051] A higher optical power density, then, can be achieved utilizing less expensive multimode laser diode bars, rather than single mode laser diode arrays, and coupling the optical output from multiple ones of the laser diodes in diode array 610 into waveguide 612. Higher coupling efficiency is achieved by utilizing a light duct 613 formed with waveguide 612. Further, the horizontal alignment between diode array 610 and coupling chip 611 is not critical, so long as the light beams are directed toward duct 613. As shown in **Figure 6B**, alignment in the vertical axis (i.e., the fast axis) is somewhat critical because of the large divergence of the light output from diode array 610 in that direction.

[0052] The pump light from the laser diode can be constrained within the confines of the

high  $\Delta n$  slab waveguide and therefore no critical alignment exists between the laser diode and the active waveguide, as would be true for conventional pumping configurations as has been discussed above. Further, there is no need to maintain single-mode propagation in the horizontal direction, as alignment tolerance are relaxed in the horizontal plane. In the vertical plane, a single optical mode can be excited to obtain maximum power density by using more precise alignment. When maximize power density is not required, the alignment tolerances in the vertical plane can also be relieved by using a thicker high refractive index contrast slab waveguide and allowing the light to propagate multimode in the vertical direction as well.

[0053] Figures 7A and 7B illustrate coupling utilizing a double-clad core. As shown in Figure 7A, light from one or more laser diodes 710 of multimode pump diode array 702 is coupled into waveguide 703 of coupling chip 701. Again, a lens duct 704 can be formed with waveguide 703 to direct light from laser diodes 710 in diode array 702 into waveguide 703. In coupling chip 701, light from waveguide 703 can be coupled into single-mode fiber 705.

[0054] Figure 7B shows a cross-section of waveguide 703. Waveguide 703 includes a single-mode core 706. Single-mode core 706 can be formed, for example, from rare-earth doped  $\text{Al}_2\text{O}_3$ ,  $\text{Y}_2\text{O}_3$ , or  $\text{TiO}_2$  to form a high refractive index core. Single-mode core 706 can be surrounded by a multi-mode cladding 707 having a lower refractive index than that of single-mode core 706, which can be formed from an intermediate refractive index contrast material such as  $\text{Al}_2\text{O}_3$  or  $\text{Y}_2\text{O}_3$ . In some embodiments, the dimensions of multi-mode cladding 707 can capture most or all of the light output from laser diode array 702. Waveguide 703 can be formed on, for example, a silica or aluminasilicate buffer layer 709 deposited on a substrate. A second buffer layer 708 can be formed over waveguide 703.

[0055] In this way, coupling chip 701 can provide efficient conversion of low optical power density light emitted from directly-coupled multimode laser diode bars to high optical power density. Where high-refractive index contrast core 706 is optically active, a laser can be formed by including a laser cavity, which can be formed by depositing mirrors on the ends of chip 701.

[0056] Very high optical-to-optical efficiencies (e.g., greater than 80%) can be achieved in coupling chip 701. For example, a multimode laser diode operating at a wavelength of 920 nm, is efficiently coupled into a single-mode output laser at about 1100 nm utilizing an active waveguide 706 formed from double-clad Yb-doped silica, for example.

[0057] Having efficiently coupled the multimode pump light into a high refractive index slab waveguide which is multimode in the horizontal plane and may or may not be single mode in the vertical plane, a single mode active waveguide located in the high refractive index portion of the slab will be efficiently pumped. Such active areas are shown, for example, in **Figures 8A and 8B**. In some embodiments, the active region of the waveguide can be "folded" or routed through many loops in order to increase the length of active material pumped and thereby increase the amplification in the waveguide.

[0058] An embodiment of a folded active region embedded within the large high refractive index slab is shown in **Figures 8A and 8B**. One skilled in the art will recognize that any appropriate configuration or routing of active area waveguide within the slab can be utilized. For example, zig-zag configurations may also be utilized in addition to the spiral configuration shown in **Figure 8A**. Additionally, linear arrays of active regions may be utilized.

[0059] **Figure 8A** shows the slow axis view (i.e., the horizontal view) and **Figure 8B** shows the fast-axis view (i.e., the vertical cross section) of an active waveguide amplifier or laser chip 801 pumped by a multimode laser diode array in accordance with the present invention. As shown in **Figure 8A**, a single mode high refractive index contrast core 803 is arranged on chip 801. Although a spiral arrangement is shown in **Figure 8A**, any arrangement that provides a long signal path between a single mode input fiber 807 and a single mode output fiber 808 can be implemented. Light output from laser diode array 802 is captured by an intermediate refractive index contrast cladding layer 804 in which the single-mode high refractive index contrast active waveguide 803 is embedded. **Figure 8B** shows a cross section of an area of chip 801 with multiple crossings of single-mode high refractive index contrast active waveguide 803. As an example, active waveguide 803 can be formed from Yb-doped  $\text{Al}_2\text{O}_3$ ,  $\text{Y}_2\text{O}_3$  or  $\text{TiO}_2$ . Intermediate refractive index contrast cladding 804 can be formed from  $\text{Al}_2\text{O}_3$  or  $\text{Y}_2\text{O}_3$ . In this arrangement, a high pump-power density can be achieved in multi-mode cladding 804, which results in highly efficient pumping of active waveguide 803.

[0060] Multi-port amplifiers can be obtained by routing multiple folded regions of active waveguide such as waveguide 803 within the high  $\Delta n$  slab 804 of chip 801. For example, multiple active cores may be routed together as shown in **Figure 8A**. A single multimode pump, therefore, can be shared among several single-mode active amplifying waveguides without the need to split the pump light and separately distribute the light to activate the single-mode

amplifying waveguides separately. There is, therefore, no need for pump splitters or multiplexers. Further, the higher area of the active region increases absorption of the pump light, reducing the need for mirrors to rout the pump light through the active regions multiple times.

[0061] **Figure 9** illustrates material depositions that provide high grade, optically transparent, highly uniform slab waveguides with highly controllable  $\Delta n$  values. The production of such waveguides is further discussed in U.S. Application Serial No. 09/903081, "As-Deposited Optical Waveguides with Low Scattering Loss and Methods for Their Manufacture," by Demaray et al, filed on July 10, 2001; U.S. Application Serial No. 10/101863, "Biased Pulse DC Sputtering of Oxide Films, by Zhang et al., filed on March 16, 2002; U.S. Application Serial No. 10/101,341, "Rare-Earth Pre-Alloyed PVD Targets for Dielectric Planar Applications," by Milonopoulou et al., filed on March 16, 2002; and Application Serial No. 09/633307, "Planar Optical Devices and Methods for their Manufacture," by Demaray et al., filed on August 7, 2000, each of which is incorporated by reference herein in its entirety.

[0062] Waveguide materials used to form active core waveguides, passive waveguides, and claddings consistent with embodiments of the present invention can be deposited by biased pulsed DC plasma vapor deposition (PVD), as described in U.S. Application Serial No. 10/101,341 (the '341 application). The physical characteristics of the optical material deposited by biased pulsed DC PVD depends on various process parameters, as discussed in the '341 application. A device, including photodetectors and other electronics, such as those shown in Figures 3A through 8B and discussed above, can be fabricated by depositing one or more active or passive optical layers and patterning the optical layers to form the waveguides and lens ducts as shown. In some applications, several deposition and patterning steps may be applied to form the desired structures.

[0063] As shown in **Figure 9**, which shows active and passive waveguide materials of highly amorphous, defect free films of aluminasilicated deposited by biased pulsed DC PVD. Further, the films have very high optical transparency, for example below 0.3 db/cm loss and, in some deposited films, less than about 0.1 db/cm loss. Therefore, deposition of films utilizing biased pulsed-DC PVD are useful for providing structures for optical coupling devices, optical amplifiers, and optical laser structures for highly efficient coupling of pump sources as has been discussed above.

[0064] In biased pulsed DC PVD, deposition is performed in a vacuum deposition chamber.

A substrate is mounted on a support which also provides an RF bias voltage to the substrate. RF power is supplied to a target formed from material to be deposited as gas is allowed into the chamber. A plasma is excited in the gas and the material is deposited on the substrate. Further, a pulsed DC signal is provided to the target. Further details regarding the deposition process are provided in the '341 application.

[0065] Coupling of light, for example from optical fiber 807 into waveguide 803, through efficient mode size conversion is illustrated in Figures 10A, 10B, and 10C. Vertically tapered mode-size conversion is further discussed in U.S. Application Serial No. 10/101492, "Mode Size Converter for a Planar Waveguide," by Tao et al, filed on March 16, 2002, herein incorporated by reference in its entirety. A very smooth vertical taper can efficiently couple light from optical fiber 807 into high refractive index contrast, core waveguide 803 very efficiently. Figure 10B shows the mode size of an optical beam at a point where light enters waveguide 803. Figure 10B shows a significantly smaller mode size in the region of waveguide 803 after the adiabatic S-taper mode size converter 1001. Mode size converter 1001 can be produced in a biased pulsed-DC PVD process with a shadow mask.

[0066] Table II shows modeling of mode diameter at the output facet of a mode converter for various core/cladding refractive index contrasts  $\Delta n$ . The dimensions in Table II refer to the dimensions of the output facet of the rectangular mode converter.

Table II

$\Delta n$	1.0 $\mu\text{m}$ x 1.0 $\mu\text{m}$	1.5 $\mu\text{m}$ x 1.5 $\mu\text{m}$	2.0 $\mu\text{m}$ x 2.0 $\mu\text{m}$	2.5 $\mu\text{m}$ x 2.5 $\mu\text{m}$
0.43%	38 $\mu\text{m}$	35 $\mu\text{m}$	14 $\mu\text{m}$	6 $\mu\text{m}$
0.3%		36 $\mu\text{m}$	20 $\mu\text{m}$	16 $\mu\text{m}$
0.2%			32 $\mu\text{m}$	24 $\mu\text{m}$

[0067] Figure 11 illustrates an image concentrator 1101 for adiabatically compressing the diameter of the mode output by a passively Q-switched microchip laser array. Image concentrator 1101 employs a reverse taper 1106, such as that first disclosed in U.S. Application Serial No. 10/101492 to Tao et al. Reverse taper 1106 can be formed vertically and/or horizontally and thereby provides coupling into a smaller mode size. A further embodiment includes a pitch size conversion such as that illustrated in Figure 5C. Embodiments of the



invention enable the mode size and pitch size conversion of individually addressable microchip laser array, so as to be tailored to standard print pixel densities for use in direct printing and micromaching applications.

[0068] Image concentrator 1101 can include an addressable array pump bar 1102 which is capable of addressing and exciting individual pixels of a microchip bar 1103. Array pump bar 1102 includes an array of laser diodes which produce light when individually addressed. Microchip bar 1103, which provides amplification as was discussed in Figures 6-8. Beam concentrator chip 1104 can include light ducts or vertical tapers in order to collect a substantial amount of light from microchip bar 1103. Further, a vertical reverse taper 1106, as is described in U.S. Application Serial No. 10/101,492, allows for a compressed output mode. As shown in Figure 11, the mode of the beam output by beam concentrator chip 1104 is much smaller than the mode of the beam in microchip bar 1103. In some embodiments, a monolithic array beam concentrator chip can convert 50  $\mu\text{m}$  or 90  $\mu\text{m}$  diameter single mode spots from microchip bar 1103 into 20 to 25  $\mu\text{m}$  diameter spots.

[0069] Figures 12A and 12B show mode sizes for some weakly-confined mode propagation in waveguides. Figure 12A illustrates a 6.2  $\mu\text{m}$  mode diameter at the output facet of a 1.5  $\mu\text{m}$  x 3.5  $\mu\text{m}$  waveguide for 980 nm light with a refractive index contrast  $\Delta n$  between the core and the cladding of about 1%. Figure 12B illustrates a 7.6  $\mu\text{m}$  mode diameter at the output facet of a 1.25  $\mu\text{m}$  x 3.5  $\mu\text{m}$  waveguide for 980 nm light with a refractive index contrast of about 1%. As is shown in Figures 12A and 12B, the optical energy is concentrated in the center of the facet.

[0070] Table III illustrates facet damage considerations in a image concentrator such as image concentrator 1101 shown in Figure 11. Table III illustrates, for representative pixel densities, the mode size required, the distance between modes, and the resulting power density in image concentrator 1101. The value of 14.2 for power density shown for 2400 dpi pixel density exceeds the damage threshold of Quartz.

Table III

Pixel Density (dpi)	Mode Pitch/Mode Size	Power Density at Facet ( $\text{GWcm}^{-2}$ )	Collimation Distance ( $\mu\text{m}$ )
600	42	0.9	842
1200	21	3.6	210
2400	11	14.2	53

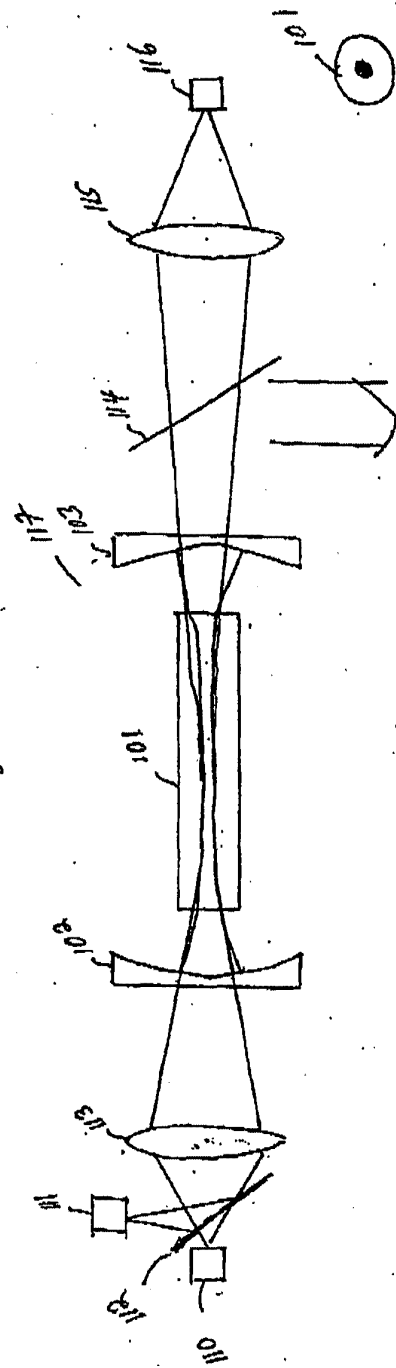
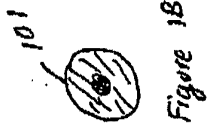
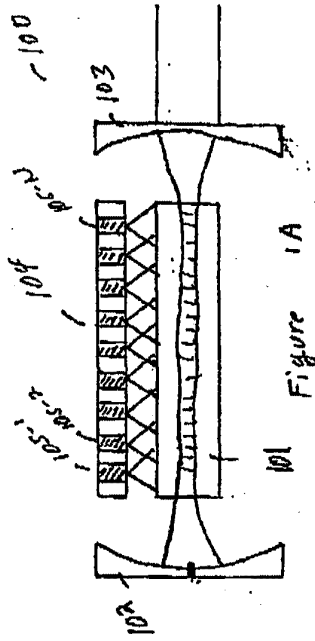
[0071] Figure 13 illustrates a vertical cavity surface emitting laser (VCSEL)-pumped microchip 1401 according to the present invention. VCSELs 1401 can be deposited on a GaAs substrate 1402. VCSELs 1401 include a dichroic output facet coating. An active gain medium 1404 can be deposited directly over VCSELs 1403. Active gain medium 1404 can be, for example, Nd, Yb, Er, Tm, Ho, Pr, or Ce doped silica. A saturable absorber 1405 can be deposited over gain medium 1404. Saturable absorber 1405 can be, for example, a Cr<sup>4+</sup> or Co<sup>2+</sup> doped silica film. A VCSEL pumped microchip 1401 can be fabricated using high volume wafer-scale semiconductor manufacturing techniques. The doped silica used for saturable absorber 1405 and active gain medium 1404, for example, can be deposited by biased pulsed-DC PVD processing techniques.

[0072] The embodiments discussed here are examples only and are not intended to be limiting of the invention. One skilled in the art will recognize multiple variations that are intended to be within the spirit and scope of the present disclosure.

I claim:

1. An optical waveguide device, comprising,  
  
at least one laser diode; and  
  
at least one high refractive index contrast slab waveguide coupled to receive light from the at least one laser diode,  
  
wherein the slab waveguide is deposited by biased pulsed DC plasma vapor deposition.
2. The optical waveguide device of claim 1, wherein the slab waveguide is formed from a highly amorphous film.
3. The optical waveguide device of claim 1, wherein the slab waveguide is highly optically transparent.
4. The optical waveguide device of claim 1, wherein the slab waveguide has a high surface smoothness.
5. The optical waveguide device of claim 1, wherein the high-refractive index contrast slab waveguide includes a lens duct.
6. The optical waveguide device of claim 1, wherein the at least one laser diode comprises a diode array.
7. The optical waveguide device of claim 1, wherein the high refractive index contrast slab waveguide includes a high refractive index active waveguide and an intermediate refractive index passive cladding.
8. The optical waveguide device of claim 7, wherein the high refractive index contrast slab waveguide is folded in the plane of the slab.
9. The optical waveguide device of claim 7, wherein the intermediate passive cladding is thick enough in the vertical axis to capture a substantial amount of light emitted from the at least one laser diode.
10. The optical waveguide device of claim 1, wherein the high refractive index contrast slab waveguide includes a mode-size converter.

11. The optical waveguide device of claim 1, wherein the at least one laser diode is a vertical cavity surface emitting laser and the high refractive index contrast waveguide is deposited over the vertical cavity surface emitting laser.
12. The optical waveguide device of claim 1, wherein the high refractive index contrast slab waveguide includes an array of waveguides.
13. The optical waveguide device of claim 11, wherein a mode size of an optical beam transmitted by the high refractive index contrast slab waveguide is less than a mode size of an incident optical beam.
14. The optical waveguide device of claim 12, wherein the high refractive index contrast slab waveguide includes at least one vertical reverse taper.
15. A method of coupling pump light into a gain medium, comprising:
  - depositing the gain medium by a biased pulsed-DC plasma vapor deposition process;
  - forming a high refractive index contrast waveguide from the gain medium; and
  - directing pump light into the high refractive index contrast waveguide.
16. The method of claim 15, wherein forming a high refractive index contrast waveguide includes patterning the gain medium.
17. The method of claim 16, further including depositing an intermediate refractive index contrast material over the high refractive index contrast waveguide.
18. The method of claim 16, wherein patterning the gain medium includes forming a lens duct.
19. The method of claim 16, wherein patterning the gain medium includes forming a horizontal taper.
20. The method of claim 16, wherein depositing the gain medium includes forming a vertical taper.



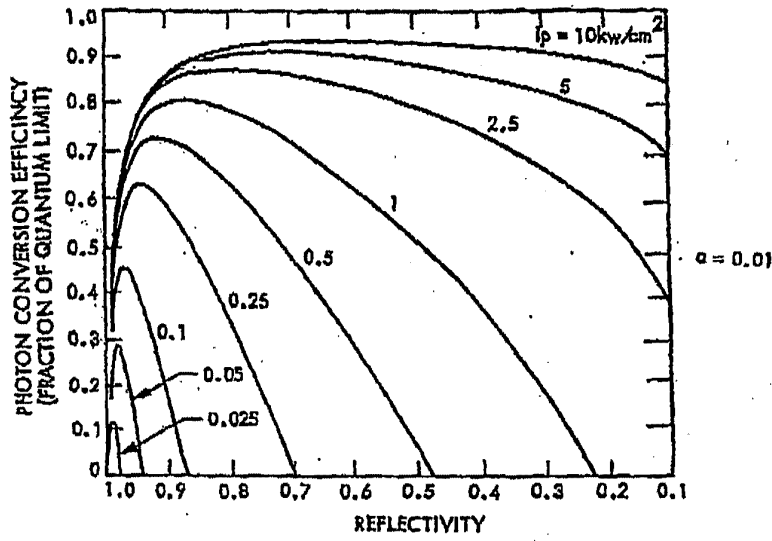


Figure 1E

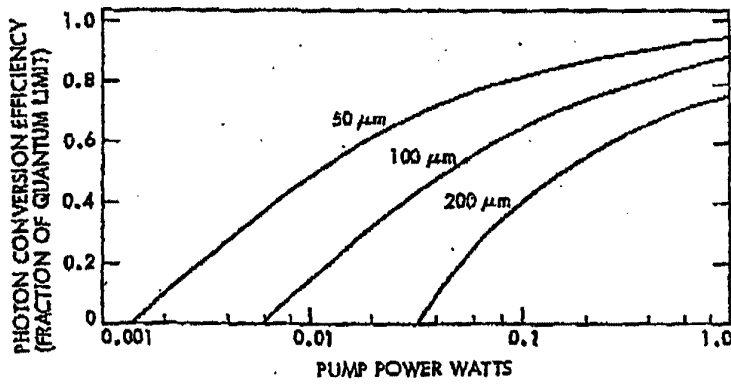
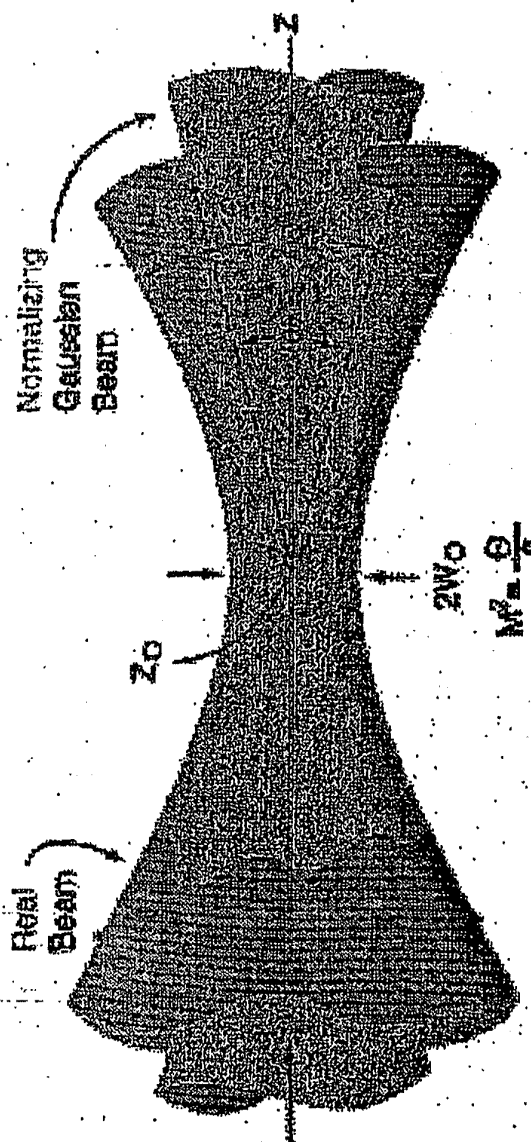


Figure 1F

Figure 2



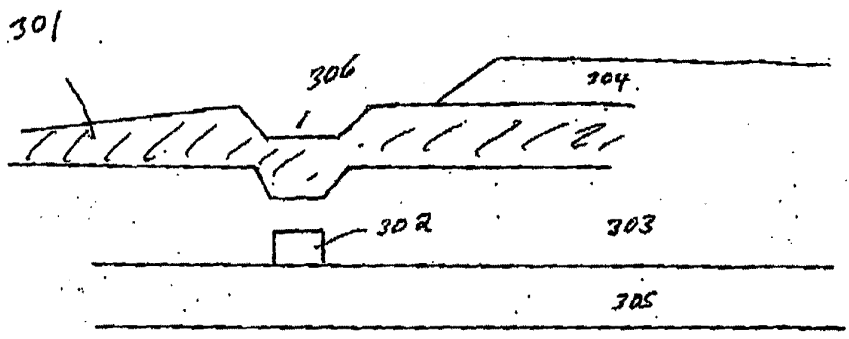


Figure 3 A

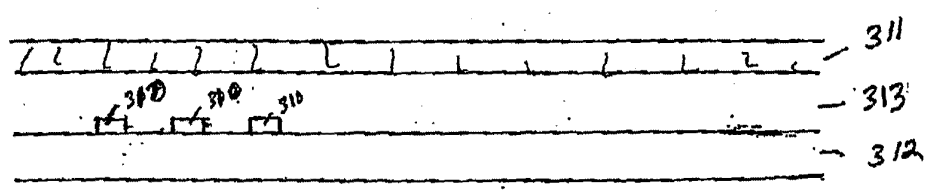


Figure 3 B



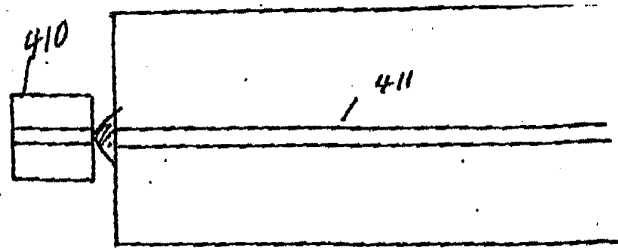


Figure 4

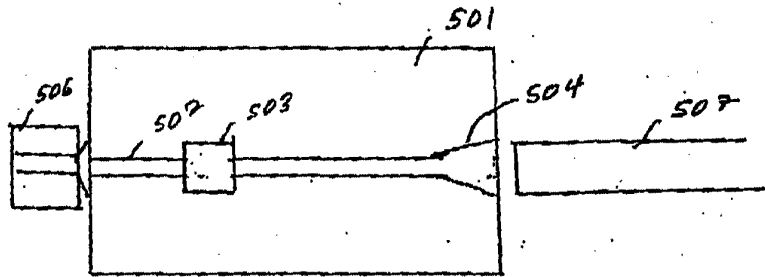


Figure 5A

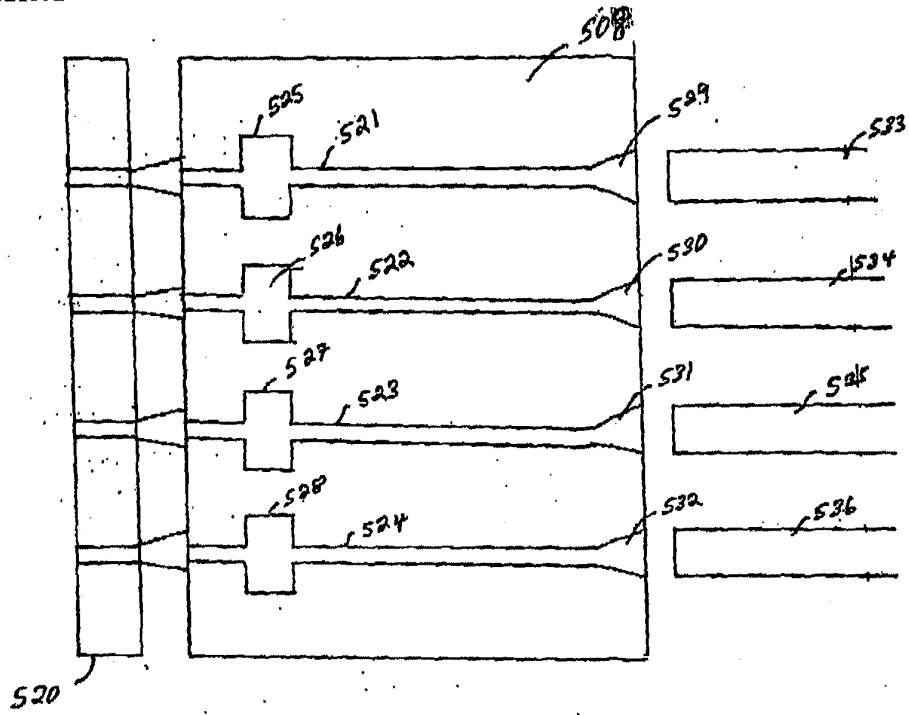


Figure 5B

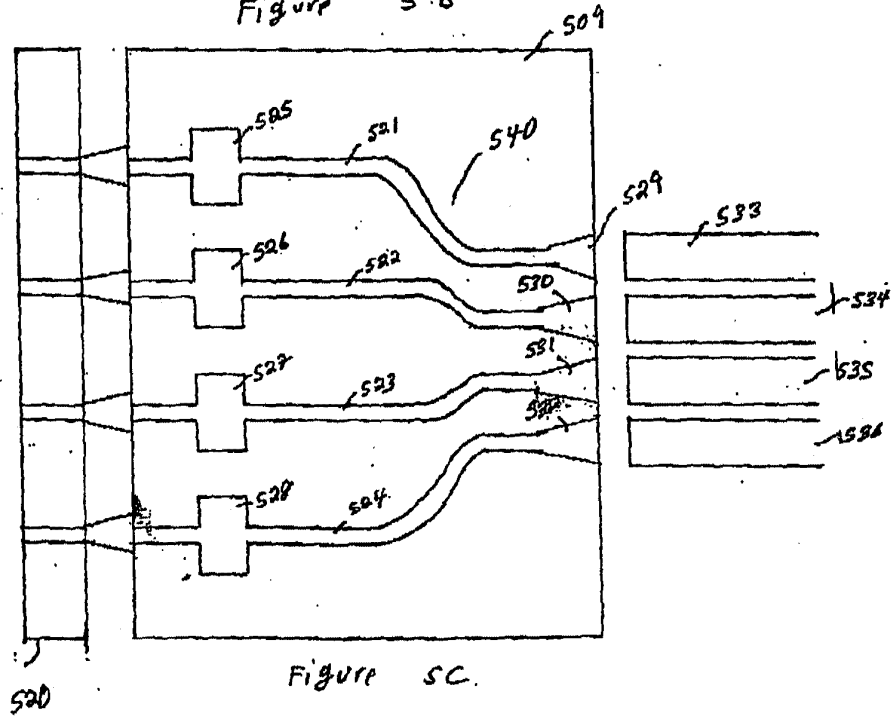


Figure 5C

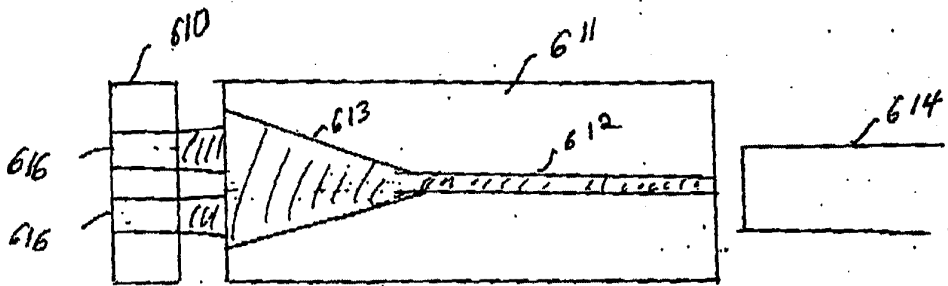


Figure 6A

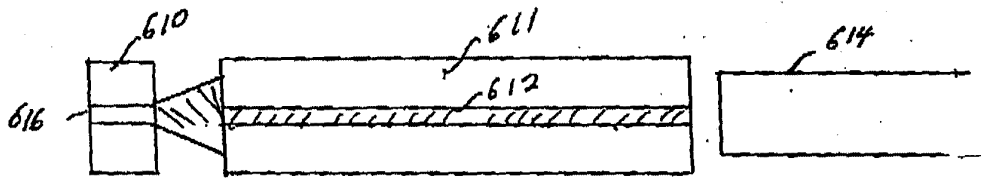


Figure 6B

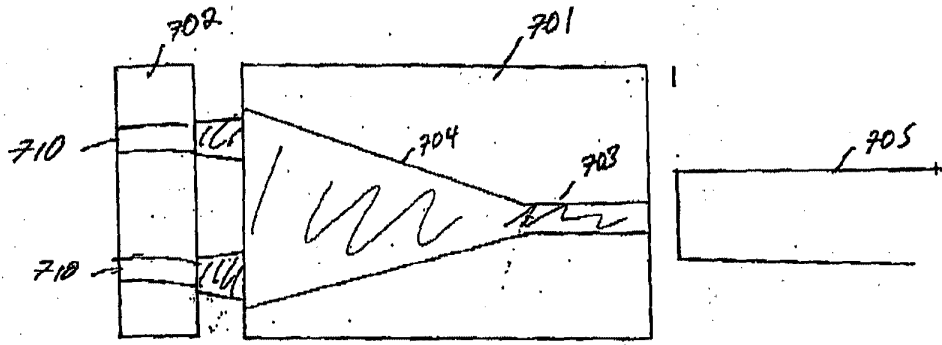


Figure 7A

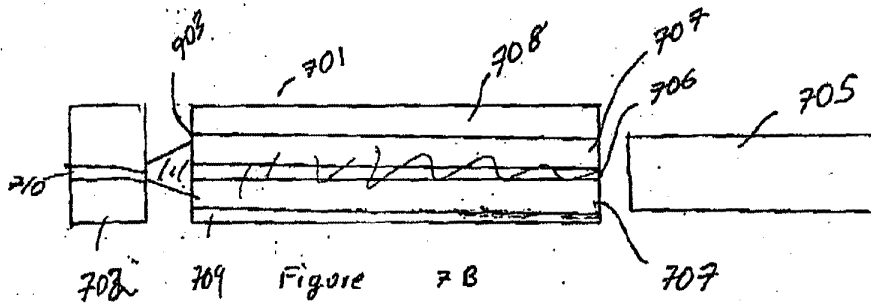


Figure 7B

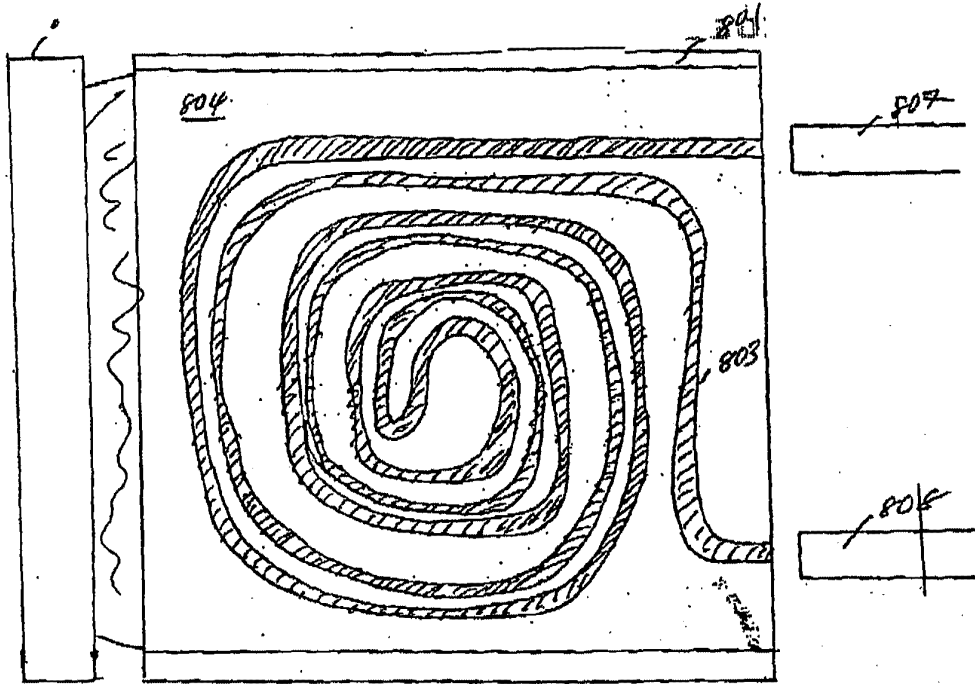


Figure 8A

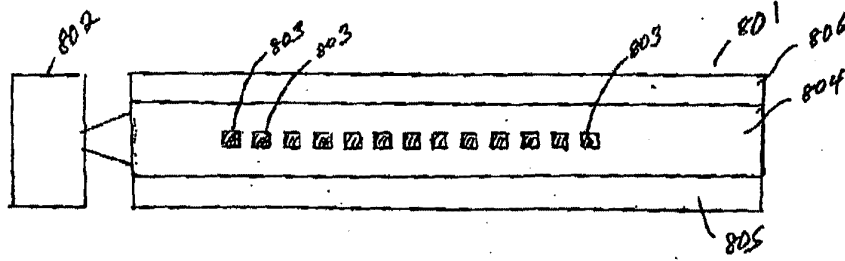


Figure 8B

- Smooth surface indicates defect free film
- Diffraction shows amorphous film through thickness
- High optical transparency

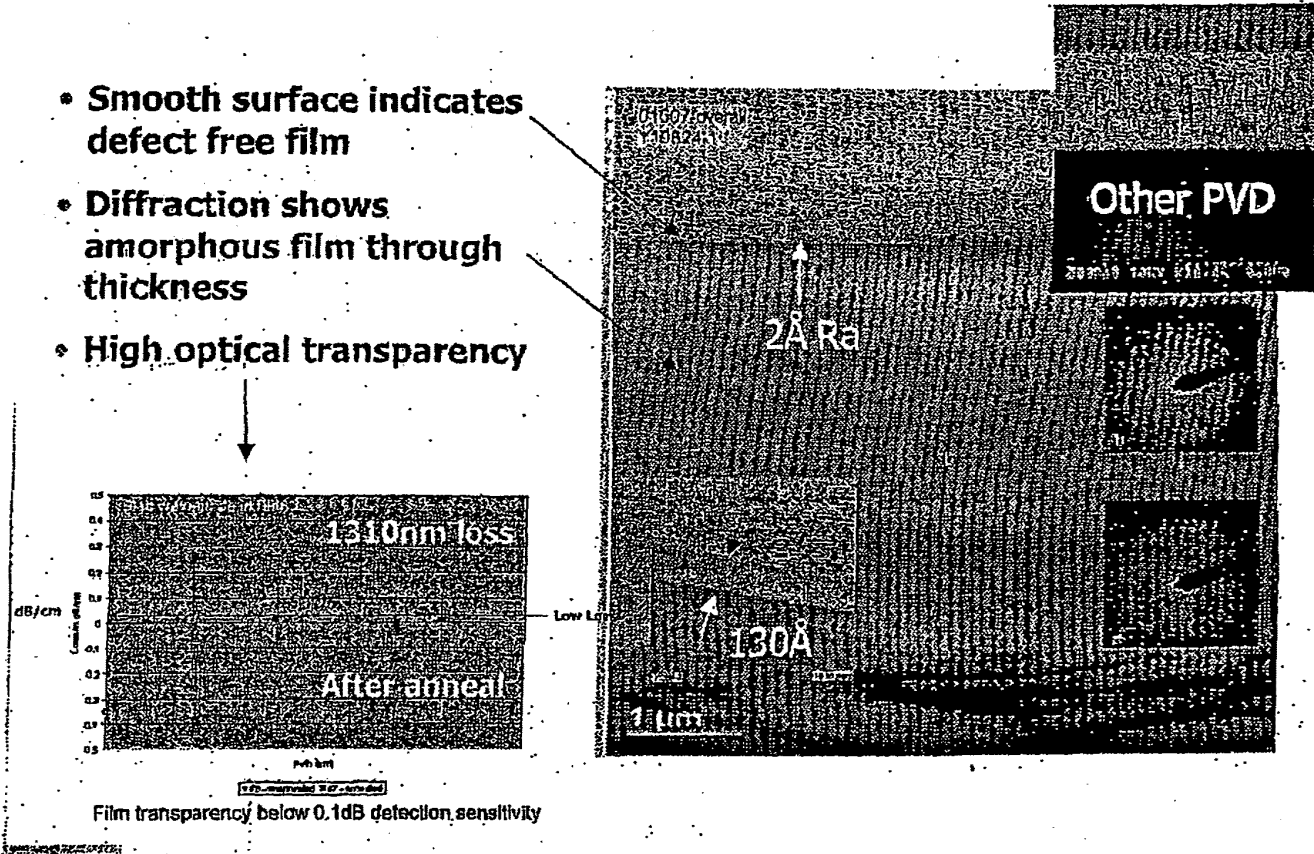


Figure 9

10/14

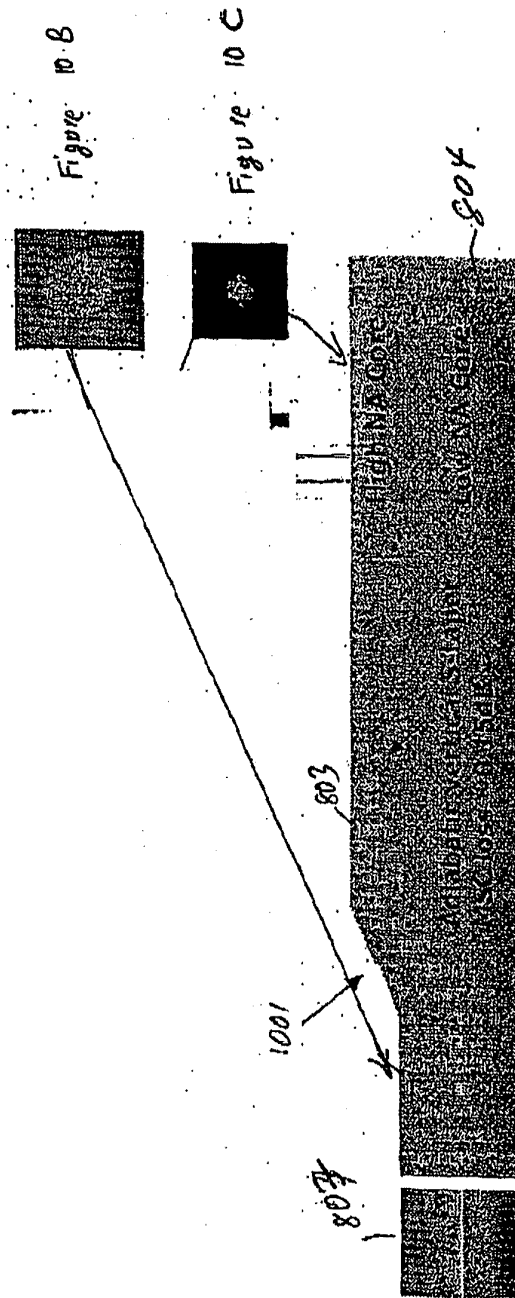


Figure 10A

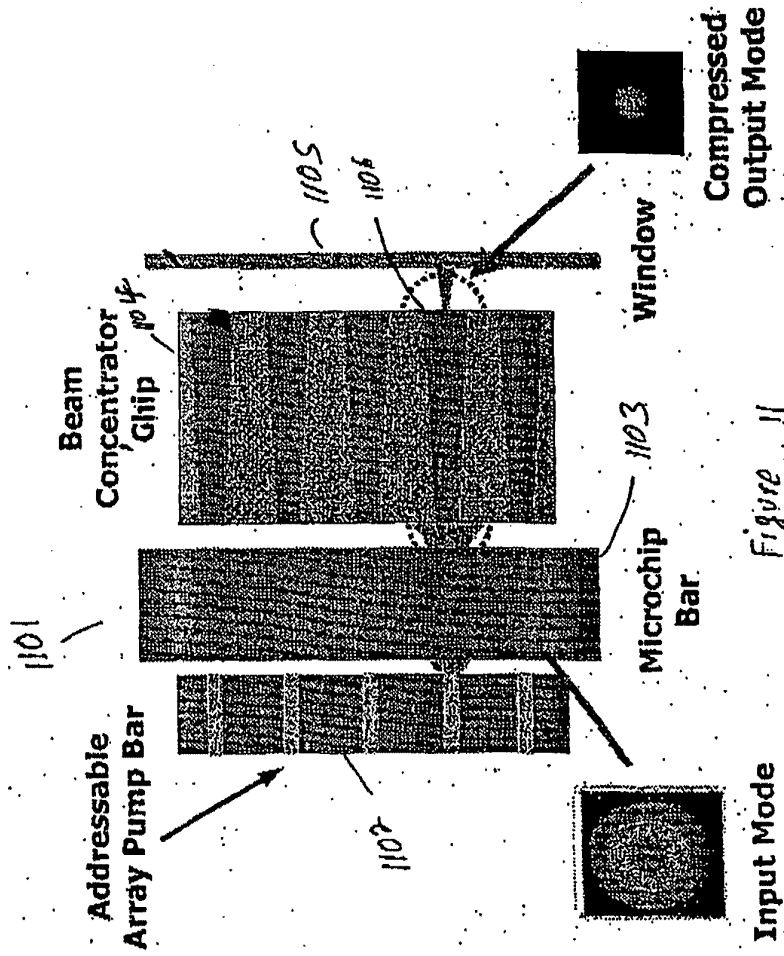


Figure 11



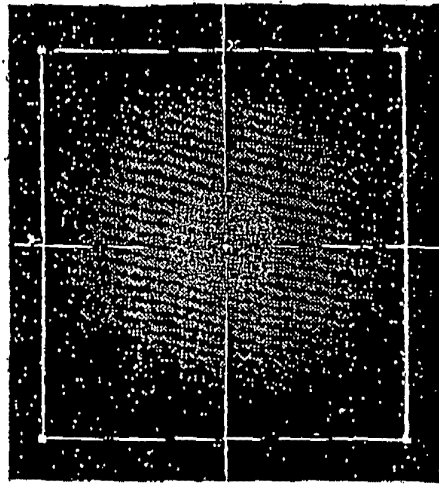


Figure 12B

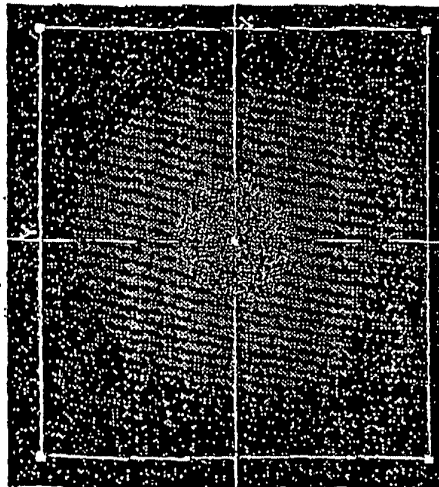


Figure 12A

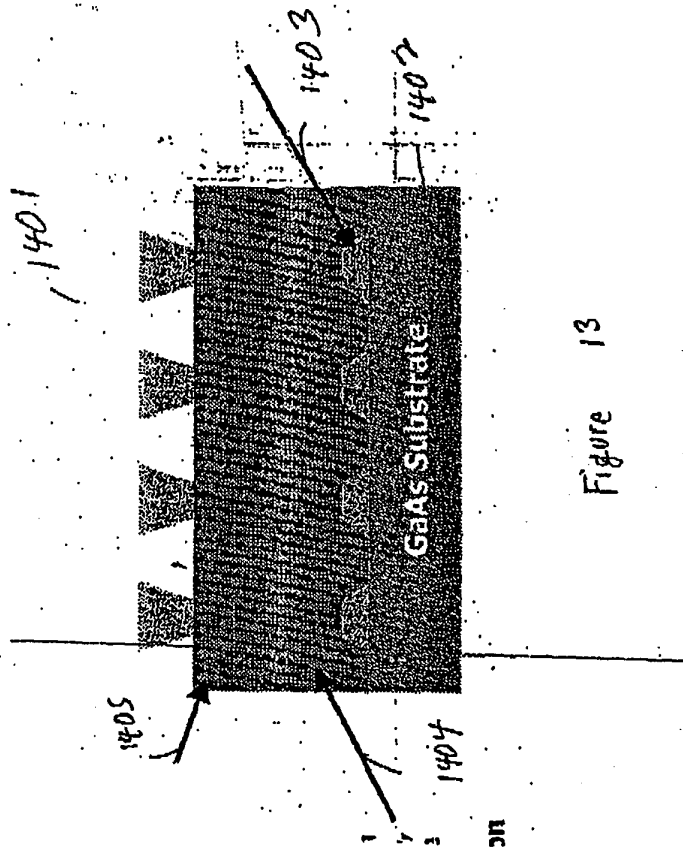


Figure 13

INTERNATIONAL SEARCH REPORT

International Application No  
PCT/US 03/24809

<b>A. CLASSIFICATION OF SUBJECT MATTER</b> IPC 7 H01S3/16 H01S3/063 H01S3/0933		
According to International Patent Classification (IPC) or to both national classification and IPC		
<b>B. FIELDS SEARCHED</b> Minimum documentation searched (classification system followed by classification symbols) IPC 7 H01S		
Documentation searched other than minimum documentation to the extent that such documents are included in the fields searched		
Electronic data base consulted during the international search (name of data base and, where practical, search terms used) EPO-Internal, INSPEC, WPI Data, PAJ		
<b>C. DOCUMENTS CONSIDERED TO BE RELEVANT</b>		
Category *	Citation of document, with indication, where appropriate, of the relevant passages	Relevant to claim No.
A	WO 02 12932 A (SYMMORPHIX INC) 14 February 2002 (2002-02-14) cited in the application page 5, line 22-26; figure 5 ---	1-20
A	JONSSON L B ET AL: "Frequency response in pulsed DC reactive sputtering processes" THIN SOLID FILMS, ELSEVIER-SEQUOIA S.A. LAUSANNE, CH, vol. 365, no. 1, April 2000 (2000-04), pages 43-48, XP004195125 ISSN: 0040-6090 paragraph '0001! ---	1,15
A	US 5 689 522 A (BEACH RAYMOND J) 18 November 1997 (1997-11-18) column 3, line 41-52 ---	5,6,18
	-/--	
<input checked="" type="checkbox"/> Further documents are listed in the continuation of box C. <input checked="" type="checkbox"/> Patent family members are listed in annex.		
* Special categories of cited documents :		
*A* document defining the general state of the art which is not considered to be of particular relevance *E* earlier document but published on or after the international filing date *L* document which may throw doubts on priority claim(s) or which is cited to establish the publication date of another citation or other special reason (as specified) *O* document referring to an oral disclosure, use, exhibition or other means *P* document published prior to the international filing date but later than the priority date claimed *T* later document published after the international filing date or priority date and not in conflict with the application but cited to understand the principle or theory underlying the invention *X* document of particular relevance; the claimed invention cannot be considered novel or cannot be considered to involve an inventive step when the document is taken alone *Y* document of particular relevance; the claimed invention cannot be considered to involve an inventive step when the document is combined with one or more other such documents, such combination being obvious to a person skilled in the art. *&* document member of the same patent family		
Date of the actual completion of the international search 21 November 2003		Date of mailing of the international search report 12/12/2003
Name and mailing address of the ISA European Patent Office, P.B. 5818 Patentlaan 2 NL - 2280 HV Rijswijk Tel. (+31-70) 340-2040, Tx. 31-651 epo nl, Fax: (+31-70) 340-3016		Authorized officer Jobst, B

INTERNATIONAL SEARCH REPORT

International Application No

PCT/US 03/24809

C.(Continuation) DOCUMENTS CONSIDERED TO BE RELEVANT		
Category *	Citation of document, with indication, where appropriate, of the relevant passages	Relevant to claim No.
A	<p>US 6 052 397 A (JEON HEONSU ET AL)                      18 April 2000 (2000-04-18)</p> <p>column 2, line 66 -column 3, line 4</p>	<p>10,11,                      13,14,                      19,20</p>
A	<p>BEACH R J: "Theory and optimization of                      lens ducts"                      APPLIED OPTICS, 20 APRIL 1996, OPT. SOC.                      AMERICA, USA,                      vol. 35, no. 12, pages 2005-2015,                      XP002262395                      ISSN: 0003-6935                      the whole document</p>	<p>5,6,18</p>
P,X	<p>US 2003/063883 A1 (DEMARAY RICHARD E ET                      AL) 3 April 2003 (2003-04-03)                      cited in the application                      paragraphs '0044!,'0045!</p>	<p>1-20</p>

**INTERNATIONAL SEARCH REPORT**

Information on patent family members

International Application No  
**PCT/US 03/24809**

Patent document cited in search report	Publication date	Patent family member(s)	Publication date	
WO 0212932	A	14-02-2002	US 2002033330 A1	21-03-2002
			AU 7700201 A	18-02-2002
			TW 520450 B	11-02-2003
			WO 0212932 A2	14-02-2002
			US 2003127319 A1	10-07-2003
-----				
US 5689522	A	18-11-1997	NONE	
-----				
US 6052397	A	18-04-2000	US 6174748 B1	16-01-2001
-----				
US 2003063883	A1	03-04-2003	NONE	
-----				

**This Page is Inserted by IFW Indexing and Scanning  
Operations and is not part of the Official Record**

**BEST AVAILABLE IMAGES**

Defective images within this document are accurate representations of the original documents submitted by the applicant.

Defects in the images include but are not limited to the items checked:

- BLACK BORDERS
- IMAGE CUT OFF AT TOP, BOTTOM OR SIDES
- FADED TEXT OR DRAWING
- BLURRED OR ILLEGIBLE TEXT OR DRAWING
- SKEWED/SLANTED IMAGES
- COLOR OR BLACK AND WHITE PHOTOGRAPHS
- GRAY SCALE DOCUMENTS
- LINES OR MARKS ON ORIGINAL DOCUMENT
- REFERENCE(S) OR EXHIBIT(S) SUBMITTED ARE POOR QUALITY
- OTHER: \_\_\_\_\_

**IMAGES ARE BEST AVAILABLE COPY.**

**As rescanning these documents will not correct the image problems checked, please do not report these problems to the IFW Image Problem Mailbox.**

(19) World Intellectual Property  
Organization  
International Bureau



(43) International Publication Date  
10 September 2004 (10.09.2004)

PCT

(10) International Publication Number  
WO 2004/077519 A2

- (51) International Patent Classification<sup>7</sup>: **H01L**
- (21) International Application Number: PCT/US2004/005531
- (22) International Filing Date: 26 February 2004 (26.02.2004)
- (25) Filing Language: English
- (26) Publication Language: English
- (30) Priority Data:  
60/451,178 27 February 2003 (27.02.2003) US  
60/506,128 25 September 2003 (25.09.2003) US
- (71) Applicants and  
(72) Inventors: **NARASIMHAN, Mukundan** [IN/US]; 293 Bluefield Drive, San Jose, CA 91536 (US). **DEMARAY, Richard, E.** [US/US]; 190 Fawn Lane, Portola Valley, CA 94028 (US). **BROOKS, Peter** [US/US]; 611 Glen Alto Drive, Los Altos, CA 94024 (US).
- (74) Agent: **GARRETT, Arthur, S.**; Finnegan, Henderson, Farabow Garrett & Dunner, L. L.P., 1300 I Street, N.W., Washington, DC 20005-3315 (US).
- (81) Designated States (unless otherwise indicated, for every kind of national protection available): AE, AG, AL, AM, AT, AU, AZ, BA, BB, BG, BR, BW, BY, BZ, CA, CH, CN, CO, CR, CU, CZ, DE, DK, DM, DZ, EC, EE, EG, ES, FI, GB, GD, GE, GH, GM, HR, HU, ID, IL, IN, IS, JP, KE, KG, KP, KR, KZ, LC, LK, LR, LS, LT, LU, LV, MA, MD, MG, MK, MN, MW, MX, MZ, NA, NI, NO, NZ, OM, PG, PH, PL, PT, RO, RU, SC, SD, SE, SG, SK, SL, SY, TJ, TM, TN, TR, TT, TZ, UA, UG, US, UZ, VC, VN, YU, ZA, ZM, ZW.
- (84) Designated States (unless otherwise indicated, for every kind of regional protection available): ARIPO (BW, GH, GM, KE, LS, MW, MZ, SD, SL, SZ, TZ, UG, ZM, ZW), Eurasian (AM, AZ, BY, KG, KZ, MD, RU, TJ, TM), European (AT, BE, BG, CH, CY, CZ, DE, DK, EE, ES, FI, FR, GB, GR, HU, IE, IT, LU, MC, NL, PT, RO, SE, SI, SK, TR), OAPI (BF, BJ, CF, CG, CI, CM, GA, GN, GQ, GW, ML, MR, NE, SN, TD, TG).
- Published:  
— without international search report and to be republished upon receipt of that report
- For two-letter codes and other abbreviations, refer to the "Guidance Notes on Codes and Abbreviations" appearing at the beginning of each regular issue of the PCT Gazette.



WO 2004/077519 A2

(54) Title: DIELECTRIC BARRIER LAYER FILMS

(57) Abstract: In accordance with the present invention, a dielectric barrier layer is presented. A barrier layer according to the present invention includes a densified amorphous dielectric layer deposited on a substrate by pulsed-DC, substrate biased physical vapor deposition, wherein the densified amorphous dielectric layer is a barrier layer. A method of forming a barrier layer according to the present inventions includes providing a substrate and depositing a highly densified, amorphous, dielectric material over the substrate in a pulsed-dc, biased, wide target physical vapor deposition process. Further, the process can include performing a soft-metal breath treatment on the substrate. Such barrier layers can be utilized as electrical layers, optical layers, immunological layers, or tribological layers.

BEST AVAILABLE COPY

## TITLE OF THE INVENTION

### **DIELECTRIC BARRIER LAYER FILMS**

#### **RELATED APPLICATIONS**

[001] The present application claims priority to U.S. Provisional Application 60/451,178, "Dielectric Barrier Film," filed on February 27, 2003, by Richard E. Demaray, Mukundan Narasimhan, and Hongmei Zhang, herein incorporated by reference in its entirety, and to U.S. Provisional Application 60/506,128, "Indium Nucleation Layer," filed on September 25, 2003, by Mukundan Narasimhan and Peter Brooks, herein incorporated by reference in its entirety.

#### **BACKGROUND**

##### **1. Field of the Invention**

[002] The present invention is related to dielectric barrier films and, in particular, dielectric barrier films formed from high-density optical material layers for utilization in optical, electrical, tribological, and bio-implantable devices.

##### **2. Discussion of Related Art**

[003] Dielectric barrier layers are becoming increasingly important as protective layers for organic light emitting diodes (OLEDs) and other optical or optoelectronic devices. Typically, dielectric barrier layers are deposited thin films with the appropriate electrical, physical, and optical properties to protect and enhance the operation of other devices. Dielectric barrier layers can be utilized in optical, electrical, or tribological devices. For example, touch screen displays require



optically transparent protective layers to protect against transmission of atmospheric contaminants as well as to protect against physical wear.

[004] Many thin film deposition technologies that may be utilized to form such dielectric layers include some form of ion densification or substrate bias densification. The densification process eliminates the columnar thin film structure that is typical of vacuum deposited chemical vapor (CVD) or physical vapor deposition (PVD) thin films. It is well known that such densification can be achieved by a secondary ion source arranged to "bombard" the film during deposition. *See, e.g.*, W. Essinger "Ion sources for ion beam assisted thin film deposition," *Rev. Sci. Instruments* (63) 11-5217 (1992). *See, also*, Hrvoje Zorc, et al. Proceedings of the Society of Vacuum Coaters, 41<sup>st</sup> Annual Technical Conference Proceedings, 243-247, 1998, which discusses the effects of moisture exposure on wavelength shift for electron beam evaporated films (e-beams). In particular, Zorc et al. demonstrated a factor of 15 or so improvement in wavelength shift for electron beam evaporated films (e-beam) as compared to e-beam films deposited with a directed ion beam source after exposure to 30% humidity at 25 °C.

[005] D. E. Morton, et al. demonstrated wide-band dielectric pass filters comprised of alternating layers of SiO<sub>2</sub> and TiO<sub>2</sub> deposited using a "cold cathode ion source" to produce oxygen ions for the purpose of providing "moisture stable stacks of dense optical films of silicon dioxide as the low index material and either titanium dioxide, tantalum pentoxide or niobium pentoxide." D. E. Morton, et al. Proceedings of the Society of Vacuum Coaters, 41<sup>st</sup> annual Technical Conference, April 18-23, 1998. The results described by Morton, et al., indicated that room temperature

resistance to humidity up to 100% humidity was attained, as measured by the optical performance of single dielectric layers deposited on substrates mounted on a rotating platen. Optical extinction coefficients for the six samples tested in Morton, et al., varied from 0.1 to 1.6 ppt, indicating the presence of significant concentrations of defects or absorption centers in the dielectric layers. Additionally, no film thickness or film thickness uniformity data was reported by Morton, et al., for ion beam energies between 134 and 632 Volts and ion beam current up to 5 amps. Morton, et al., therefore fail to describe a film that would operate as a good barrier layer for optical devices.

[006] Self biased physical vapor deposition, such as ion coating or activated reactive deposition, are well-known means of providing hard wear resistant coatings. However, these coatings are either deposited at several hundred Volts of bias voltage and form penetrating surface treatments with the ion flux penetrating the surface to react with the substrate material, or they are ion assisted for the purpose of decreasing the columnar structure of the film. A "filtered cathodic vacuum arc" (FCVA-reference - [http://www.nanofilm-systems.com/eng/fcva\\_technology.htm](http://www.nanofilm-systems.com/eng/fcva_technology.htm)) has been used to form a dense film from an ion flux. In this case, ions are created and separated from the neutral vapor flux by a magnetic vector so that only species having a positive charge impinge the substrate. The bias voltage can be preset so that average translational energy ranges from about 50 to several hundred Volts are available. Lower ion energies are not reported due to the problem of extracting and directing a lower energy ion flux with a useful space charge density. Although quite rough due to re-sputtering at the high ion energies, hard protective layers of alumina,

and other materials such as tetrahedral carbon, can be deposited with this process on cutting tools and twist drills with commercial levels of utility. Due to the limitation of the coating species to the ion flux, coating rates are low. The best or hardest carbon films are often deposited with the lowest rate of deposition, e.g., 0.3 nanometers per second on substrates up to 12" in diameter.

[007] Transmission of a ZnO film deposited by FCVA at 600 nm wavelength is increased from about 50% at room temperature to above 80% for single films by increasing the temperature of deposition to above 230 °C, with the best transmission at 600 nm of about 90% at a deposition temperature of 430 °C and a substrate bias voltage not greater than about 50 Volts. This high temperature processing indicates the use of a thermal anneal process for repair of ion-induced damage to the films. For FCVA deposition with a 200 Volt bias the transmission is much reduced. FCVA films deposited in this fashion have been shown to be polycrystalline. The defect structures exhibited in the FCVA layer are too large for formation of effective optical barrier layers. Additionally, ion sputtering of crystalline films is dependent on the crystal orientation, leading to higher surface roughness. Defect structures formed in a protective layer can degrade the optical quality of the layer and also provide paths for diffusion of atmospheric contaminations through the layer, compromising the protective properties of the layer.

[008] Ion biased films have shown significant progress toward the goal of providing a satisfactory barrier for protection of electronic and optical films, such as, for example, photovoltaic, semiconducting and electroluminescent films. Particularly organic light emitting diodes, which utilize calcium or other very reactive metal

doped electrodes and other hydroscopic or reactive materials, can be protected by such films. However, the most biased process to date, the filtered Cathodic Vacuum Arc Coating Technology or FCVAC process, is reported to produce films with a particle density greater than about 1 defect per square centimeter. It may be that the high resputtering rate at the high voltages used in this process cause surface roughening. Certainly, the presence of a particle represents a defect through which diffusion of water vapor or oxygen can proceed. Also, the roughness of the surface formed by the FCVAC process impacts the stress and morphology and also the transparency and the uniformity of the index of refraction. The resputtered film may flake from the process chamber shields or be drawn to the film surface by the large electrostatic field present in an ion beam process. In any case, the particle defect density for particles greater than the film thickness also determines pin hole density or other defects caused by discontinuous deposition of the film because line of sight films can not coat over a particle that is larger than the thickness of the film, let alone a particle many times greater in size than the thickness of the film.

[009] In the case of ion-bias or self-bias energies exceeding several electron volts, the translational energy of the ion participating in the bias process can exceed the chemical binding energy of the film. The impacting ion, then, can either forward scatter atoms of the existing film or back sputter atoms of the existing film. Likewise, the participating ion can be adsorbed into the growing film or it can also scatter or absorb from the film surface. Sputtering of the existing film and scattering from the existing film are both favored at incoming angles of about 45° from the horizontal. In most ion coating processes, the ion beam is directed at a normal incidence to the

surface to be coated. However, as noted, at ion energies exceeding the chemical threshold, and particularly at energies exceeding 20 Volts or so, damage to the film or the substrate resulting from the ion energy in excess of the chemical binding energy is significant, and results in surface roughness, increased optical absorption characteristics, and creation of defects.

[010] In the case of the FCVA process, roughness is an increasing function of the film thickness, increasing from about 0.2 nanometers roughness for a 50 nanometer film to about 3 nanometers for a 400 nanometer Cu film indicating substantial roughening of the polycrystalline copper surface due to differential sputtering by the self biased incoming copper ions. Such a film will scatter light, particularly at the interface between two layers of different refractive index. To date, barrier or dielectric properties of FCVA produced films have not been found.

[011] Charging of the deposited film is also a particular problem with ion beam deposited dielectrics. To date, no low temperature dielectric and also no ion beam dielectric is known that has ever been shown to provide the electrical quality required for a transistor gate layer, for example. The ion beams embed charged ions in the film, leading to large negative flat band voltages and fields that can not be passivated at temperatures below about 450 °C. The surface charge of the dielectric layer results in slow accumulation of capacitance, preventing the sharp onset of conduction in a transistor application. Consequently, no as-deposited low temperature dielectric, biased or unbiased, has been proposed for low temperature transistor applications or is known at this time.

[012] Therefore, there is a need for high quality, dense dielectric layers for utilization as barrier layers in optical, electrical, tribological, and biomedical applications.

#### SUMMARY

[013] In accordance with the present invention, one or more dielectric layers formed from layers of metal-oxide materials deposited by a pulsed, biased, wide area physical vapor deposition process are presented. A dielectric barrier layer according to the present invention can be formed from at least one highly densified metal oxide layer. Dielectric barriers according to the present invention can be highly densified, highly uniform, ultra smooth amorphous layers with ultra low concentrations of defects, providing for superior performance as protective layers against physical wear and atmospheric contamination of underlying structures as well as overlying structures that may be deposited to form an electrical, optical, or medical device. Barrier layers according to the present invention can also be self-protecting optical layers, electrical layers, or tribological layers that can be utilized actively in optical or electrical devices.

[014] Therefore, barrier layers according to the present invention includes a densified amorphous dielectric layer deposited on a substrate by pulsed-DC, substrate biased physical vapor deposition, wherein the densified amorphous dielectric layer is a barrier layer. Further the deposition can be performed with a wide area target. A method of forming a barrier layer according to the present inventions includes providing a substrate and depositing a highly densified, amorphous, dielectric material over the substrate in a pulsed-dc, biased, wide target physical vapor deposition

process. Further, the process can include performing a soft-metal breath treatment on the substrate.

[015] Dielectric barrier stacks can include any number of individual layers including one or more barrier layers according to the present invention. In some embodiments, the individual barrier layers can be optical layers. Typically, alternating layers of low and high index of refractory metal oxide materials can be arranged to form anti-reflective or reflective coatings in optical devices, for example. As such, dielectric barriers according to the present invention provide a protective function as well as being a functional part of an optical device. In some embodiments of the invention, for example, dielectric barriers according to the present invention can be utilized in cavity enhanced LED applications, or in formation and protection of transistor structures. Additionally, the beneficial dielectric properties of some embodiments of barrier layers according to the present invention can be utilized as electrical layers to form resistors or capacitive dielectrics.

[016] In some embodiments, a soft metal (e.g., indium) breath treatment can be utilized before deposition of a barrier layer. Such a breath treatment is shown to significantly improve surface roughness and enhance WVTR characteristics for embodiments of barrier layers according to the present invention.

[017] These and other embodiments of the invention are further discussed and explained below with reference to the following Figures. It is to be understood that both the foregoing general description and the following detailed description are exemplary and explanatory only and are not restrictive of the invention, as claimed. Further, specific explanations or theories regarding the deposition or performance of

barrier layers or soft-metal breath treatments according to the present invention are presented for explanation only and are not to be considered limiting with respect to the scope of the present disclosure or the claims.

#### **BRIEF DESCRIPTION OF THE DRAWINGS**

[018] Figures 1A and 1B illustrate a deposition apparatus for depositing barrier layer films according to the present invention.

[019] Figure 1C illustrates a barrier layer deposited on a substrate according to embodiments of the present invention.

[020] Figures 2A, 2B, 2C, 2D, 2E and 2F illustrate examples of devices with dielectric stacks of barrier layers according to embodiments of the present invention.

[021] Figure 3 shows a microcavity enhanced LED structure utilizing dielectric stacks of barrier layers according to embodiments of the present invention.

[022] Figure 4 shows a bottom gate transistor device with a dielectric stack of barrier layers according to embodiments of the present invention.

[023] Figure 5 shows a top gate transistor device with a dielectric stack of barrier layers according to embodiments of the present invention.

[024] Figure 6 shows an example of a microcavity enhanced LED structure similar to that shown in Figure 3 further protected by a dielectric stack of barrier layers according to embodiments of the present invention.

[025] Figure 7 shows another example of a microcavity enhanced LED structure similar to that shown in Figure 3 further protected by a dielectric stack of barrier layers according to embodiments of the present invention.



[026] Figure 8 shows an example TiO<sub>2</sub> barrier layer according to embodiments of the present invention deposited on a reactive aluminum layer after exposure to a high humidity, high temperature environment for an extended period of time.

[027] Figure 9 shows an example silica/alumina barrier layer according to embodiments of the present invention deposited on a reactive aluminum layer after exposure to a high humidity, high temperature environment for an extended period of time.

[028] Figure 10 shows an SEM photograph of a cross section of an embodiment of a dielectric stack of barrier layers according to embodiments of the present invention.

[029] Figure 11 shows transmission versus wavelength curves for various examples of dielectric stacks of barrier layers according to embodiments of the present invention.

[030] Figures 12A and 12B illustrate a single barrier layer structure deposited with and without a soft-metal breath treatment according to embodiments of the present invention.

[031] Figure 13 shows a Flexus Stress Measurement apparatus that can be utilized to test barrier layers.

[032] Figure 14 illustrates a measurement of the wafer bow using the Flexus Stress Measurement apparatus illustrated in Figure 13.

[033] Figure 15 illustrates the stress in various deposited barrier layers according to embodiments of the present invention as a function of temperature through a single temperature cycle after deposition.

[034] Figures 16A, 16B, 16C, and 16D show atomic force microscopy measurements of surface roughness for some barrier layer films according to embodiments of the present invention.

[035] Figure 17 illustrates a water vapor transmission test that can be utilized to characterize barrier layers deposited according to embodiments of the present invention.

[036] Figures 18A through 18D illustrate the effects of different In/Sn breath treatment parameters on the surface roughness of the deposited barrier layer according to the present invention.

[037] Figures 19A and 19B illustrate the effects of the substrate on surface roughness.

[038] Figure 20 illustrates a barrier layer according to the present invention that further operates as a thin film gate oxide.

[039] Figures 21A and 21B illustrate the effect of substrate composition on the surface roughness of a deposited barrier layer according to the present invention.

[040] Figures 22A and 22B illustrate that the character of the barrier layer deposition according to embodiments of the present invention effect surface roughness.

[041] In the figures, elements having the same designation have the same or similar functions.

### DETAILED DESCRIPTION

[042] Barrier layers according to some embodiments of the present invention are deposited in a pulsed-dc, substrate biased, wide target physical vapor deposition process that is described further below with respect to some particular examples of such barrier layers. Some embodiments of barrier layers according to embodiments of the present invention can be characterized as highly densified, highly uniform, highly amorphous layers with particularly low defect concentrations and high surface smoothness. Further, barrier layers according to embodiments of the present invention can have beneficial optical and electrical characteristics that allow such barrier layers to be self-protecting optical or electrical layers in optical or electrical devices formed with these layers.

[043] For example, some embodiments of barrier layers according to the present invention can have excellent optical transparency characteristics. Further, the index of refraction of individual barrier layers is dependent on the material of deposition and therefore stacking of multiple barrier layers according to the present invention can result in highly controllable, and self protecting, reflecting or anti-reflecting coatings for optical devices. Additionally, barrier layers according to some embodiments of the present invention can be doped with optically active impurities to form optically active layers, which are also self-protecting. For example, depositions of rare-earth ions such as Erbium or Ytterbium can result in optical amplifiers or frequency converters.

[044] Additionally, embodiments of barrier layers according to the present invention can have highly beneficial dielectric properties and can therefore be utilized as self-protecting electrical layers. Some barrier layers according to embodiments of

the present invention, for example, can be utilized as resistance layers. Other embodiments can be utilized as high-dielectric constant layers in capacitor devices. Embodiments of dielectrical barrier layers that are useful for such devices are further discussed below.

[045] RF sputtering of oxide films is discussed in Application Serial No. 09/903,050 (the '050 application), filed on July 10, 2001, by Demaray et al., entitled "Planar Optical Devices and Methods for Their Manufacture," assigned to the same assignee as is the present invention, herein incorporated by reference in its entirety. Further, targets that can be utilized in a reactor according to the present invention are discussed in U.S. Application serial no. 10/101,341, filed on March 16, 2002, assigned to the same assignee as is the present invention, herein incorporated by reference in its entirety. Methods of depositing oxides in a pulsed-dc, substrate biased, wide-target physical vapor deposition (PVD) process are further discussed in U.S. Application serial no. 10/101863, filed on March 16, 2002, (hereinafter referred to as "the pulsed, biased process") assigned to the same assignee as is the present application, herein incorporated by reference in its entirety.

[046] Figures 1A and 1B illustrate a reactor apparatus 10 for sputtering of material from a target 12 according to embodiments of the present invention. In some embodiments, apparatus 10 may, for example, be adapted from an AKT-1600 PVD (400 X 500 mm substrate size) system from Applied Komatsu or an AKT-4300 (600 X 720 mm substrate size) system from Applied Komatsu, Santa Clara, CA. The AKT-1600 reactor, for example, has three or four deposition chambers connected by a vacuum transport chamber. These AKT PVD reactors can be modified such that

pulsed DC power is supplied to the target and RF power is supplied to the substrate during deposition of a material film.

[047] Apparatus 10 includes a target 12 which is electrically coupled through a filter 15 to a pulsed DC power supply 14. In some embodiments, target 12 is a wide area sputter source target, which provides material to be deposited on substrate 16. Substrate 16 is positioned parallel to and opposite target 12. Target 12 functions as a cathode when power is applied to it and is equivalently termed a cathode. Application of power to target 12 creates a plasma 53 below target 12. Magnet 20 is scanned across the top of target 12. Substrate 16 is capacitively coupled to an electrode 17 through an insulator 54. Electrode 17 can be coupled to an RF power supply 18.

[048] For pulsed reactive dc magnetron sputtering, as performed by apparatus 10, the polarity of the power supplied to target 12 by power supply 14 oscillates between negative and positive potentials. During the period of positive potential, the insulating layer on the surface of target 12 is discharged and arcing is prevented. To obtain arc free deposition, the pulsing frequency of pulsed DC power supply 14 can exceed a critical frequency that can depend, at least partly, on target material, cathode current and reverse time. High quality oxide films can be made using reactive pulse DC magnetron sputtering in apparatus 10.

[049] Pulsed DC power supply 14 can be any pulsed DC power supply, for example an AE Pinnacle plus 10K by Advanced Energy, Inc. With this example supply, up to 10 kW of pulsed DC power can be supplied at a frequency of between 0 and 350 KHz. The reverse voltage is 10% of the negative target voltage. Utilization

of other power supplies will lead to different power characteristics, frequency characteristics and reverse voltage percentages. The reverse time on this embodiment of power supply 14 can be adjusted to between 0 and 5  $\mu$ s.

[050] Filter 15 prevents the bias power from power supply 18 from coupling into pulsed DC power supply 14. In some embodiments, power supply 18 is a 2 MHz RF power supply and, for example, can be a Nova-25 power supply made by ENI, Colorado Springs, Co. Therefore, filter 15 is a 2 MHz band rejection filter. In some embodiments, the band-width of the filter can be approximately 100 kHz. Filter 15, therefore, prevents the 2 MHz power from the bias to substrate 16 from damaging power supply 18.

[051] However, both RF and pulsed DC deposited films are not fully dense and most likely have columnar structures. These columnar structures are detrimental for optical applications and to formation of barrier layers due to the scattering loss and pinholes caused by the structure. By applying a RF bias on wafer 16 during deposition, the deposited film can be densified by energetic ion bombardment and the columnar structure can be substantially eliminated.

[052] In the production of some embodiments of a barrier layer according to the present invention using, for example, the AKT-1600 based system, target 12 can have an active size of about 675.70 X 582.48 by 4 mm in order to deposit films on substrate 16 that can have dimension about 400 X 500 mm. The temperature of substrate 16 can be held at between about 50C and 500C. The distance between target 12 and substrate 16 can be between about 3 and about 9 cm. Process gas (for example, but not limited to, mixtures of Ar and O<sub>2</sub>) can be inserted into the chamber

of apparatus 10 at a rate up to about 200 sccm while the pressure in the chamber of apparatus 10 can be held at between about 0.7 and 6 millitorr. Magnet 20 provides a magnetic field of strength between about 400 and about 600 Gauss directed in the plane of target 12 and is moved across target 12 at a rate of less than about 20-30 sec/scan. In some embodiments utilizing the AKT 1600 reactor, magnet 20 can be a race-track shaped magnet with dimension about 150 mm by 600 mm.

[053] Figure 1C shows a dielectric barrier layer 110 deposited on a substrate 120 according to the present invention. Substrate 120 can be any substrate, for example plastic, glass, Si-Wafers or other material. Substrate 120 may further include devices or structures that can be protected by barrier layer 110, such as organic light-emitting diode (OLED) structures, semiconductor structures, or other barrier layer structures. Barrier layer 110 can be a metallic oxide where the metal can be Al, Si, Ti, In, Sn or other metallic oxides, nitrides, halides, or other dielectrics. For example, a high index of refraction barrier layer can be formed by deposition of  $\text{TiO}_2$  from a titanium target with example deposition parameters designated as 7KW/200W/200KHz/60Ar/90O<sub>2</sub>/950s (7 KW of pulsed-dc target power, 200 W of substrate bias power, 200 KHz is the pulsing frequency of the pulsed-dc target power, 60 sccm Ar gas flow, 90 sccm O<sub>2</sub> gas flow, 950s total deposition time). Another example lower index of refraction barrier layer can be formed from a target that is 92% Al and 8% Si (i.e. 92-8 or 92/8 layers) in a process designated as 3KW/200W/200KHz/85Ar/90O<sub>2</sub>/1025 (3KW of pulsed-dc target power, 200 W of substrate bias power, 200 KHz pulsing frequency of the pulsed-dc target power, 85 sccm Ar flow, 90 sccm O<sub>2</sub> flow for 1025 sec of deposition time). As is further

discussed below, a wide range of process parameters can be utilized to deposit barrier layers according to the present invention.

[054] Barrier layers according to the present invention can be formed from any oxide materials. For example, MgO, Ta<sub>2</sub>O<sub>5</sub>, TiO<sub>2</sub>, Ti<sub>4</sub>O<sub>7</sub>, Al<sub>2</sub>O<sub>3</sub>, SiO<sub>2</sub>, silicon-rich SiO<sub>2</sub>, and Y<sub>2</sub>O<sub>3</sub>. Oxide compounds of Nb, Ba, Sr, and Hf can also be utilized to form barrier layers according to the present invention. Further, barrier layers can be doped with rare-earth ions to produce optically active layers. Parameters provided herein for deposition of particular layers (e.g., the TiO<sub>2</sub> layers and the 92-8 layers discussed above) are exemplary only and are not intended to be limiting. Further, individual process parameters are approximations only. A wide range of individual parameters (e.g., power levels, frequencies, gas flows, and deposition times) around those stated can be used to form barrier layers according to the present invention.

[055] Dielectric barrier layer 110 can be characterized as a highly dense, uniform, defect free amorphous dielectric layer that may also have high optical transparency. Such films can be deposited in a pulsed-dc, substrate biased PVD process from a metallic target in an Ar/O<sub>2</sub> gas flow. As is further discussed below, some embodiments of dielectric barrier layer 110 have excellent surface roughness characteristics as well. Typically, as is discussed further below and with the examples and data provided, water vapor transmission rates for dielectric films according to embodiments of the present invention are tested in a MOCON test apparatus (MOCON refers to MOCON testing service of Minneapolis, MN) to be less than  $1 \times 10^{-2}$  gm/m<sup>2</sup>/day and are often less than  $5 \times 10^{-3}$  gm/m<sup>2</sup>/day.



[056] Dielectric barrier stacks can be formed by depositing further barrier layers over barrier layer 110. Any number of stacked barrier layers can be utilized in order that the resulting structure not only function as a barrier layer, but may have other purposes in the resulting device as well. Further, a soft metallic breath treatment may be applied prior to deposition of a barrier layer according to embodiments of the present invention. A soft-metallic breath treatment refers to exposure of the substrate to a soft metallic vapor, as is further explained below.

[057] Figure 2A shows an embodiment of a dielectric stack 120 that can be utilized as a barrier structure as well as providing further optical functions. Dielectric stack 120 includes multiple barrier layers 101, 102, 103, 104, and 105 according to embodiments of the present invention. Each of barrier layers 101, 102, 103, 104, and 105 can be deposited utilizing deposition methods as described with more detail in U.S. Application Serial No. 10/101,863. The deposition is described generally above with respect to apparatus 10. In general, dielectric stack 120 can include any number of layers. In particular, dielectric stack 120 can include only a single barrier layer. The particular example of a barrier stack 120 shown in Figure 2A includes five layers, layers 101, 102, 103, 104 and 105. In the example of dielectric stack 120 shown in Figure 2A, dielectric layers 101, 103 and 105 are formed of a high index material such as titania ( $\text{TiO}_2$ ). Layers 102 and 104 can be formed of a low index material such as silica ( $\text{SiO}_2$ ), possibly doped with alumina (e.g., 92% silica and 8% alumina by cation percents, the 92-8 layer). Barrier stack 120 can be deposited directly on a substrate 100 as shown in Figure 2A or deposited on a layer 107 as shown in Figure 2D. Layer 107 is a layer to be protected from atmospheric contaminants or physical

damage and may include an optical or electrical device or another layer. Substrate 100 is a substrate on which layer 107 or dielectric stack 120 is formed. In some embodiments, substrate 100 can also provide a barrier to atmospheric contamination of layer 107. In some devices, further structures may be deposited over barrier layer structure 120.

[058] Table 1 illustrates deposition parameters for some example dielectric stack structures 120 according to the present invention. As described above, each of stacks 120 illustrated in Table 1 are formed utilizing an AKT 4300 PVD system using a Biased Pulsed DC Reactive Scanning Magnetron PVD Process as further described in U.S. Patent Application Serial No. 10/101,863, which has been previously incorporated by reference. Further, apparatus 10 as described above with respect to Figures 1A and 1B, can be clustered in the AKT 4300 PVD system with a loadlock chamber, an outgassing chamber, and may be equipped with plasma shields and a shield heater. As shown in Figure 2A, dielectric stack 120 for these examples includes 5 layers -- 3 alternating layers of  $\text{TiO}_2$  and 2 layers of 92-8  $\text{SiO}_2/\text{Al}_2\text{O}_3$  (92%/8% by cation concentration).

[059] Dielectric stack 120 for each of the stacks shown in Table 1 was deposited directly on substrate 100. Substrate 100 for each of the stacks formed was first loaded into the loadlock of apparatus 10. The loadlock of apparatus 10 was pumped to a base pressure of less than about  $10^{-5}$  Torr. The sheets of substrate 100, which may be of glass or plastic, was then transferred to a heat chamber of apparatus 10 and held at a temperature of about 300 °C for about 20 mins in order to outgas any moisture already accumulated by substrate 100. For polymer based substrates, for

example, the pre-heat step can be eliminated or performed at a lower temperature depending on the plastic substrate used. In some cases, the substrate and shield heaters of apparatus 10 can be disabled. The substrate column of Table 1 shows the composition of substrate 100 utilized in the deposition process.

[060] In each of stacks 1 through 6 illustrated in Table 1, the composition of the dielectric barrier layers in dielectric stack 120 is  $\text{TiO}_2/92\text{-}8/\text{TiO}_2/92\text{-}8/\text{TiO}_2$ , indicating that layers 101, 103 and 105 as shown in Figure 2A are  $\text{TiO}_2$  layers and layers 102 and 104 as shown in Figure 2A are  $\text{SiO}_2/\text{Al}_2\text{O}_3$  (92%/8% by cation concentration). The  $\text{TiO}_2$  layers are deposited with the parameters shown in the  $\text{TiO}_2$  Deposition Process column. The process details are given in the format: target power/bias power/pulsing frequency/Ar flow/ $\text{O}_2$  flow/deposition time. Target power refers to the power supplied to target 12 of apparatus 10. Bias power refers to the power supplied by bias generator 18 to electrode 17 on which substrate 100 is mounted in place of substrate 16 as shown in Figure 1A and capacitively coupled to electrode 17. The Ar and  $\text{O}_2$  flow rates across substrate 100 are then described in units of standard cubic centimeter/min (sccm). Finally, the deposition time is given. For example, the  $\text{TiO}_2$  layers for stack number 1 illustrate in Table 1 were deposited with a target RF power of about 7 kW, with about 200 W of bias power, pulse frequency of about 200 KHz, an Ar flow rate of about 60 sccms, an  $\text{O}_2$  flow rate of about 90 sccms, and a deposition time of about 950s. The measured thickness of a typical  $\text{TiO}_2$  layer deposited according to the process described in the  $\text{TiO}_2$  Deposition Process column is shown in the measured thickness  $\text{TiO}_2$  column of Table 1.

[061] Similarly, the deposition parameters for deposition of silica/alumina layers for each dielectric stack 120 shown in Table 1 are shown in the silica/alumina (92/8) deposition process column. As indicated, each of the silica/alumina layers for stack numbers 1-6 shown in Table 1 are about 92% Silica and about 8% alumina by cation concentration. For example, in stack number 1 illustrated in Table 1, the silica/alumina layers were deposited with the power to target 12 being about 3 kW, the bias power to electrode 17 was about 200 W, the frequency of pulsed DC power supply 14 was about 200 kHz, the Ar flow rate was about 85 sccm, the O<sub>2</sub> flow rate was about 90 sccm, and the deposition time was about 1,005 sec.

[062] In general, in this disclosure a dielectric barrier layer referred to as 92/8 layer refers to a barrier layer formed from continuous deposition of a dielectric barrier layer from the 92% Silica/8% Alumina target. A dielectric barrier layer referred to as a 92-8 layer refers to a barrier layer formed in steps from the 92% Silica/8% Alumina target. A 92-8 layer can be formed, for example, on plastic substrates whereas 92/8 layers can be formed on Si-wafers or glass substrates that are not so sensitive to heat.

[063] In each of the stacks illustrated in Table 1, the reverse time for pulsed-DC power supply 14 was fixed at about 2.3 microseconds. The spacing between target 12 and substrate 100 was ~60mm, and the spacing between magnet 20 and target 12 was ~4-5 mm. The temperature of substrate 100 was about 200 °C and the shield heater of apparatus 10 was set to about 250 °C. The home offset of magnet 20 was set to be about 20 mm and the scan length was about 980 mm. The total pressure inside the chamber of apparatus 10, in plasma 53, during deposition of the

TiO<sub>2</sub> layers was about 5-6 mT. The total pressure inside the chamber, in plasma 53, during deposition of the silica/alumina layers was about 8-9 mT.

[064] In some barrier stacks according to the present invention, barrier layers are deposited by a reactively sputtered thin film layer or layers, formed by a process as previously described in the pulsed, biased deposition process, U.S. Application Serial No. 10/101,863. The pulsed, biased deposition process combines optical quality vacuum films having uniquely dense morphologies free of the columnar defects that are typical of non-biased vacuum thin films with parts per million uniformity and control of the optical index and birefringence. Very high resolution ellipsometry also demonstrates that a wide range of film index can be deposited with extinction coefficients which are zero across the visible and in the near IR region, and uniform on the order of parts per million providing substantially perfect transparency. As a result of the high level of densification and the low defect concentration, it is demonstrated that these very transparent films also provide superior diffusion barrier protection for moisture ingress as measured by steam permeation. Lastly, the same films demonstrate much higher dielectric breakdown under high voltage stress, also a result of the low levels of defects.

[065] Figure 8 shows a sample after exposure to a high-humidity, high temperature environment for an extended period of time. In the sample shown in Figure 8, about 200 nm of TiO<sub>2</sub> was deposited on a reactive aluminum layer that had been deposited on a 4" silicon wafer. The sample was kept in a chamber at about 85 °C with a relative humidity of about 100% for about 500 hours. As can be seen in

Figure 8, no defects are visible on the wafer indicating a high level of protection of the underlying reactive aluminum layer.

[066] Figure 9 shows a sample with a silica/alumina layer according to the present invention after exposure to a high-humidity, high-temperature environment for an extended period of time. In the sample shown in Figure 9, about 10 nm of aluminum is deposited on a 4" silicon wafer. About 100 nm of silica/alumina is deposited over the aluminum. The sample was then placed in a pressure cooker at about 250 °C with about 3.5 atm of saturated steam for about 160 hours. Again, no defects are visible on the wafer indicating a high level of protection of the underlying reactive aluminum layer. In another example, the thin reactive Al on a Si wafer was tested under the same conditions without a barrier layer and became transparent within minutes of the testing.

[067] Selected metal oxide films deposited with the previously disclosed process, from tens of nanometers to more than 15 microns, are not only impervious to moisture and chemical penetration as a film, but can also provide protection to an underlying layer or device from the effect of gas or moisture ingress while serving as an optical, electrical and/or tribological layer or device, rendering substantial manufacturing and environmental margins to the respective layers and devices. The subject process has been demonstrated on wide area substrates of glass and metal as well as low temperature material such as plastics.

[068] Table 4 shows Vickers Hardness (MPa) values obtained by testing an Al<sub>2</sub>O<sub>3</sub> barrier layer and an Er-doped alumina/silicate (40% alumina/60% silica) films on a Si-Wafer. The Al<sub>2</sub>O<sub>3</sub> barrier layer was deposited in a

3kW/100W/200KHz/30Ar/44O<sub>2</sub>/t process with a 2.2 μs reverse time. The Er, Yb doped Al<sub>2</sub>O<sub>3</sub> was deposited with the process 6kW/100W/120KHz/60Ar/28O<sub>2</sub>/t process with a 1.2 μs reverse time. As can be seen in Table 4, the hardness as indicated generally by the Vickers number is large compared to conventionally deposited alumina films.

[069] Returning to Figure 2A, a dielectric stack 120 is deposited on substrate 100. Each of barrier layers 101, 102, 103, 104, and 105 can be optical layers (i.e., layers that are optically useful). Substrate 100 may be any glass, plastic, metallic, or semiconductor substrate. The thickness of layers 101, 102, 103, 104, and 105 of dielectric stack 120 can be varied to form either an anti-reflective coating or a reflective coating. Figure 2B shows a transparent conducting layer 106 deposited over dielectric stack 120. Transparent conducting layer 106 can be, for example, an indium tin-oxide layer. Figure 2C illustrates a substrate 100 with dielectric stacks 120 deposited on both a top surface and a bottom surface of substrate 100. The particular example shown in Figure 2C includes an embodiment of dielectric stack 120 with layers 101, 102, 103, 104, and 105 deposited on a top surface of substrate 100 and another embodiment of dielectric stack 120, shown having layers 108, 109, 110, 111, and 112 in Figure 2C, deposited on the bottom surface of substrate 100. Again, layers 108, 110, and 112 may be high index layers according to the present invention (e.g., TiO<sub>2</sub> layers) and layers 109 and 111 may be lower index layers such as silica/alumina layers. Examples of deposition parameters for dielectric stack 120 can be found in Table 1. As another example of a stack of barrier layers according to the present invention that provides good transmission characteristics is a four-layer stack

TiO<sub>2</sub>/SiO<sub>2</sub>/TiO<sub>2</sub>/SiO<sub>2</sub> layering of thicknesses 12.43 nm, 36.35 nm, 116.87 nm, and 90.87 nm, respectively, deposited on glass provides a high transparency in the wavelength range of about 450 nm and 650 nm.

[070] In Figure 2D dielectric stack 120 is shown protecting a layer 107. Layer 107 is any layer of material that should be protected by a transparent barrier layer. For example, layer 107 may be a reactive metal such as aluminum, calcium or barium, layer 107 may be a fragile layer such as a conductive transparent oxide, or layer 107 may include an active optical or electrical device. As discussed above, the individual layers of dielectric stack 120 can provide protection both from incursion of atmospheric contaminants and protection against physical damage of layer 107. In some embodiments, the layer thickness of dielectric layers (e.g., layers 101, 102, 103, 104, and 105 shown in Figure 2D) of dielectric stack 120 are arranged to form either a transparent or reflective film at particular wavelengths. One skilled in the art can determine the thickness of individual films in dielectric stack 120 to form a reflective or anti-reflective film of dielectric stack 120. In some embodiments, where layer 107 is a metal such as aluminum, barium, or calcium, the device shown in Figure 2D forms a highly stable mirror. Figure 2E shows a dielectric stack 120 protecting a layer 107 where layer 107 has been deposited on substrate 100. Further, a transparent conducting layer 106 has further been deposited over dielectric stack 120. Figure 2F shows a structure where a second barrier stack 120 has been deposited on the bottom surface of substrate 100.

[071] Figure 10 shows a cross sectional SEM view of an example dielectric stack according to the present invention. Again, a five-layer TiO<sub>2</sub>/92-8 stack is



shown with thickness 550 nm for the TiO<sub>2</sub> layers and 970 nm for the 92-8 silica/alumina. The example shown in Figure 10 is a dielectric mirror stack such as that used to form a microcavity LED.

[072] Although Figures 2A through 2F show various configurations and utilizations of a barrier stack 120 having five layers, in general, a barrier stack 120 according to the present invention may be formed of any number of barrier layers. Further, the examples of barrier layers 101, 102, 103, 104, and 105 illustrated in Figures 2A through 2F illustrate examples of optical layers according to the present invention where those optical layers also function as self-protecting barrier layers in that they protect themselves as well as the particular surface or device on or below which they are deposited. Additionally, one or more of barrier layers 101, 102, 103, 104, and 105 may include optically active dopant ions such as rare-earth ions in order to provide more optically active functionality. Further, in accordance with the present invention, one or more of layers 101, 102, 103, 104, and 105 may be layers other than barrier layers according to the present invention. Each of the barrier layers described with respect to Figures 2A through 2F can be deposited utilizing a pulsed, biased deposition process as has been described in U.S. Application Serial No. 10/101,863 to form a highly densified layer of material with very low defect concentrations.

[073] Figure 3 shows another structure 321 utilizing dielectric stacks of barrier layers according to the present invention. As shown in Figure 3, structure 321 includes a dielectric stack 315 deposited on a substrate 316. Substrate 316 may be formed, for example, of glass or plastic materials. A transparent conductive layer 314, such as for example indium tin oxide, is deposited on dielectric stack 315. Layer

313 can be an electroluminescence layer such as, for example, a phosphor-doped oxide or fluoride material, rare earth doped silicon rich oxide light emitting device, or an organic light emitting polymer, OLED (organic light emitting diode) or polymer stack. A metal layer 312, which may be aluminum and may be doped with calcium or barium, is deposited on the side near layer 313. A second dielectric stack 317 can be formed on the bottom of substrate 316.

[074] Structure 321 illustrated in Figure 3 is an example of a microcavity enhanced LED, protected from water and reactive gas which may diffuse through substrate 316 by dielectric stacks 315 and 317. When layer 312 is a metal layer, a microcavity is formed between layer 312 and dielectric stack 315. Dielectric stack 315 can out-couple light emitted from electroluminescence layer 313. Layer 313 emits light when it is electrically biased as a result of a voltage applied between transparent conducting layer 314 operating as an anode and conducting layer 312 operating as a cathode. The layers of dielectric stack 315 and dielectric stack 317 may be arranged to contain the light emitted by layer 313 between layer 317 and metallic layer 312, forming an etalon arrangement to guide light along substrate 316. Additionally, dielectric layer 317 may be arranged to transmit light produced by layer 313, thereby forming a monitor arrangement with light being emitted substantially normal to substrate 316.

[075] Figure 11 illustrates the transmission data collected from examples of dielectric stacks according to the present invention. The metrology equipment utilized in taking the data resulting in Figure 11 was a Perkin Elmer Lambda-6 Spectrophotometer. Four samples were measured and each were 5 layer stacks of

TiO<sub>2</sub>/92-8 as described above. Two samples have the same thickness layers (55 nm TiO<sub>2</sub> and 100 nm 92-8). As illustrated in Figure 11, the two different runs have almost the same transmission spectrum demonstrating the repeatability of the deposition process. The third example had a different thickness arranged so as to shift the transmission spectrum towards the blue. The fourth example was generated after the third example was maintained under 85/85 (85 C 85 % humidity) test conditions for 120 hours. It can be observed that the humidity and heat did not have a significant impact on the transmission characteristics of the mirror stack, again demonstrating the functionality of such dielectric stacks as protection layers as well as optical layers (i.e., no measurable wet-shift). A similar result was obtained after 500 hours of test with the 85/85 conditions with no measurable wet-shift.

[076] Figure 6 shows an example of another structure 633 with a microcavity enhanced LED structure 321 as described with Figure 3 covered and protected by a structure 622 such as those shown in Figures 2A through 2F. In structure 321, as shown in Figure 6, layers 314, 313, and 312 have been patterned. A structure 622 with dielectric stacks 618 and 620 deposited on opposite sides of a substrate 619 can be formed separately. Dielectric stacks 618 and 619 are formed as described with dielectric stacks 120 of Figures 2A through 2F. Structure 622 can then be epoxied over structure 321 in order to seal and protect structure 321. Epoxy layer 621, for example, can be an EVA epoxy.

[077] Figure 7 shows another structure 700 with an example of a microcavity enhanced LED structure 321 as described with Figure 3 covered and protected by a structure 623 such as those shown in Figures 2A through 2F. Covering

structure 623 includes substrate 619, with dielectric stack 620 deposited on substrate 619, epoxied to device 321.

[078] Figure 4 illustrates another example of barrier layers according to the present invention that also function as electrical layers (i.e., layers with electrical function such as providing resistance or function as the dielectric in a capacitor structure). The structure shown in Figure 4 illustrates an example of a bottom gate transistor structure 422 according to the present invention. Transistor structure 422 is formed on a substrate 416, which may be a plastic or glass material. In the embodiment illustrated in Figure 4, a dielectric stack 415 according to the present invention is deposited on a top surface of substrate 116 and a second dielectric stack 417 according to the present invention is deposited on a bottom surface of substrate 116. Dielectric stacks 417 and 415 each can include layers of high index and low index dielectric materials, as discussed above. The high index and low index dielectric materials, for example  $\text{TiO}_2$  and silica/alumina layers as described above, each have low-voltage flat bands and low surface defects and therefore are suitable for use as thin film transistor structures. A semiconductor layer 423 is deposited on barrier stack 415 and patterned. Semiconductor layer 423 can be a semiconductor such as silicon, germanium, or may be of zinc oxide or a polymer material. Layers 424 and 425 form source and drain layers in contact with semiconductor layer 423. Layer 426 can be formed of a material with a high dielectric constant, such as any of the dielectric layers forming dielectric stacks 415 and 417, for example the high-dielectric strength  $\text{TiO}_2$  material deposited by the processes described here. Layer 427 is an inter layer and layer 428 is the gate metal.

[079] Figure 5 shows an example of a top gate transistor device 529.

Transistor device 529 is formed on a substrate 516 that is protected from atmospheric contamination (for example water or gasses) and physical wear and abrasion by dielectric stacks 515 and 517. Dielectric stacks 515 and 517 are formed from one or more layers of optical material as discussed above with dielectric stack 120. Gate layer 530 is deposited on dielectric stack 515. Layer 530 may be a metallic layer such as aluminum or chrome. A gate oxide layer 531 is deposited over layer 530. A semiconductor layer 532 is deposited on gate oxide layer 531 over layer 530. Semiconducting layer 532 can be similar to layer 423 of Figure 4. Layers 533 and 534 are source and drain layers, respectively, and are similar to layers 424 and 428 of device 422 of Figure 4 and may be formed from a conducting metal, conducting oxide, or a conducting polymer, for example.

[080] Dielectric stacks with barrier layers according to the present invention can have atomically smooth film surfaces, independent of the film thickness. Additionally, dielectric stacks with barrier layers according to the present invention can have film transparencies that are unmeasurably different from zero. These dielectric stacks represent a new capability for biased barrier film defect levels and barrier protection. Few products requiring dielectric barrier protection from water and oxygen, such as OLED displays, can tolerate a defect every square centimeter. Some embodiments of barrier layers as 2.5 nanometers and as thick as 15 microns have been deposited that exhibit an average surface roughness of about 0.2 nm, indicating a damage free process. Such layers exhibit an optical quality surface for all film thicknesses deposited, representative of the high amorphous film uniformity

attainable with these processes that produce embodiments of the barrier layer according to the present invention.

[081] Dielectric barrier layers according to the present invention have been shown to protect ultra thin reactive metal films of aluminum from steam heat oxidation from 125 to 250 °C at pressures of 3.5 ATM of pure steam for hundreds of hours with no visible defect on 100mm silicon wafers. Consequently, it is clear that both titanium oxide and alumina/silicate barrier layers, as described herein, can provide long term protection of reactive films which are pin hole free up to the area of one or both wafers. One pin hole in the protective dielectric barrier on a 100 mm wafer, with an area of approximately 75 square centimeters, would translate into a pin hole density of about 0.0133 per square centimeter. As shown in Figures 8 and 9, there were two wafers, one with aluminosilicate and one with titania barrier dielectric coatings, that were failure free. The total area between the two wafers was 150 square centimeters. If there were 1 defect on these two wafers the defect density would be 0.00666 per square centimeter. However, since the wafers were free of defects, the actual defect density could not be measured from the results of only two wafers. As indicated, then, the actual defect density was less than 0.0133 per square centimeter and likely less than 0.007 per square centimeter.

[082] In some embodiments of the invention, a soft metal, such as indium or indium-tin, breath treatment can be performed before deposition of one or more barrier layers such as those discussed above. It is likely that the soft metal breath treatment can be utilized to release stress between the dielectric barrier layer and the

substrate. Further, the soft metal breath treatment can act to nucleate for further growth of pin-hole free or defect-free barrier layer films on the substrate.

[083] Figures 12A and 12B show a single barrier layer structure 1200 with deposited on a substrate 1201 with and without a soft-metal breath treatment according to the present invention. In Figure 12A, a barrier layer 1203 such as is described above is deposited directly on substrate 1201. Substrate 1201 can be any suitable substrate material, including glass, plastic, or Si Wafers, for example. Substrate 1201 can, for example, include an OLED structure or other optically active structure which requires high optical throughput or an electrical structure that may utilize the barrier layers as electrical layers. Barrier layer 1203 can be any one or more barrier layers as is described above. As illustrated in Figure 12A, barrier layer 1203 can develop stress-related surface roughness during deposition and use.

[084] Figure 12B illustrates the results of depositing barrier layer 1203 following a soft-metal breath treatment according to some embodiments of the present invention. As is shown in Figure 12B, the stress is apparently relieved resulting in a barrier layer with much better surface smoothness.

[085] A soft-metal breath treatment according to some embodiments of the present invention includes an exposure of the substrate for a short time to a soft metal vapor followed by a heat treatment. An indium-tin breath treatment, for example, involves exposure of the substrate to indium-tin from an indium-tin target in a pulsed-dc process and a subsequent heat treatment. Direct exposure to indium-tin-oxide vapor does not yield the particular beneficial results illustrated below. Without being bound by a particular theory that may be presented in this disclosure, an In/Sn breath

treatment can relieve stress in the deposited barrier layer, improving surface smoothness and MOCON WVTR performance.

[086] In a particular example of formation of barrier layer structure 1200, an embodiment of a soft-metal breath treatment was performed on a plastic substrate 1201. A breath treatment of Indium/Tin, for example, can be performed from an Indium Tin (90%/10%) Target. The process for performing the indium/tin breath treatment can be designated as 750W/0W/200 KHz/20Ar/0O2/10sec. In other words, the pulsed-dc, biased, wide target PVD process is operated with a 90% Indium/10% Tin target, an Ar flow of 20 sccms running at a constant power of 750 W in a pulsed PVD system 10 (Figure 1A) (Pulsing Frequency 200 KHz, Reverse time 2.2  $\mu$ sec) for 10 secs in the AKT 1600 PVD system using the Pinnacle Plus PDC power supply. Then, the breath treatment continued and substrate 1201 was transferred into a load lock of an AKT 4300 Tool and the Tool was pumped to a base pressure of less than about  $1 \times 10^{-5}$  Torr. The substrate was then transferred to a Heat Chamber at 130 °C at  $1 \times 10^{-8}$  Torr where it is thermally treated at 130 °C for about 25 min.

[087] Substrate 1201 (with the indium/tin breath treatment described above) was then moved to a second chamber where barrier layer 1203 is deposited. Barrier layer 1203 can be formed, as indicated above, from a 92-8 Alumino-Silicate (92% Si/8% Al) target with the deposition performed at room temperature.

[088] The process parameters for the deposition of the embodiment of 92-8 barrier layer 1203 can be 3KW/200W/200KHz/85Ar/90O2/x. Therefore, the process is performed with about 3 KW PDC power, about 200 KHz Pulsing Frequency, and about 2.2 microseconds reverse time. Bias power can be held at about 200 W. A Gas



flow of about 85 sccms of Ar and about 90 sccms of O<sub>2</sub> was utilized. In deposition of this particular embodiment, the deposition process was power cycled where the on cycle was about 180 secs long and the off cycle was about 600 secs long for 9 cycles. The thickness of the resulting barrier layer 1203 was then about 1600 Å. In a particular test, the process described above was utilized for deposition of a barrier structure 1200 with substrate 1201 being three plastic sheets of size 6 inch by 6 inch (Dupont Teijin PEN films 200 μm thick, referred to as a PEN substrate). In general, any barrier layer (e.g., the 92-8 or TiO<sub>2</sub> layers discussed above) can be deposited following a soft-metal breath treatment. As discussed before, examples of processes for embodiments of barrier layers according to the present invention are presented here but wide ranges of process parameters can result in barrier layers according to the present invention.

[089] Barrier layer structure 1200 on substrate 1201 can then be tested using a variety of techniques, some of which are described below. In particular, the stress in layer 1203 can be measured using a Flexus Stress Measurement technique. Surface roughness can be measured utilizing an atomic force microscope (AFM), and water vapor transmission rates (WVTR) can be measured in a high pressure, high humidity pressure cooker device.

[090] Figure 13 illustrates a Flexus Scanning Assembly 1300 that can be utilized to test barrier layer structure 1200. In Flexus Scanning Assembly 1300, a light beam for laser 1310 is directed onto the upper surface of barrier layer 1203 by a mirror 1312. The reflected light beam from barrier layer 1203 is detected by detector 1314. Detector 1314 measures the deflection of the light beam from the beam

reflected by mirror 1312. The optical section 1316, which can include laser 1310, mirror 1312, and detector 1314, can be scanned across substrate 1201 and the angle of deflection  $\theta$ , which is related to the radius of curvature of substrate 1201 as shown in relation 1318.

[091] The thin film stress in barrier 1203 can be calculated utilizing the changes in substrate deformation measured by Flexus apparatus 1300 as optical portion 1316 is scanned. As is shown in relationship 1318, the angle of the reflected beam can be monitored during the scan and the inverse of the radius of curvature  $R$  of substrate 1201 can be calculated from the derivative of the angle as a function of position in the scan.

[092] In some cases, Flexus apparatus 1300 can utilize a dual wavelength technology to increase the range of film types that the tool is capable of measuring. Each Flexus apparatus 1300, then, can have more than one laser 1310 available for scanning the wafer since different film types will reflect different wavelengths of light. Further, the reflected laser intensity provides a good indication of the quality of the measurement. In general, low light intensity at detector 1314 indicates a poor measurement condition.

[093] In Flexus apparatus 1300, stress can be determined using Stoney's equation. In particular, stress in layer 1203 can be determined by measurements of the radius of curvature before deposition of layer 1203 and the radius of curvature after deposition of layer 1203. In particular, according to Stoney's equation, the stress can be given by

$$\sigma = \frac{E_s}{(1-\nu_s)} \frac{t_s^2}{6t_f} \left( \frac{1}{R_s} - \frac{1}{R_f} \right),$$

where  $E_s/(1-\nu_s)$  is the biaxial modulus of substrate 1201,  $\sigma$  is the stress of substrate 1201,  $t_s$  is the substrate thickness,  $t_f$  is the film thickness,  $R_s$  is the pre-deposition radius of curvature, and  $R_f$  is the post deposition radius of curvature. To obtain the best results, both measurements of the radius of curvature should be performed on the same tool to minimize systematic error in the measured radius. In addition, because the shape of a wafer is unique and because stress is calculated based on the change in deformation of the substrate, each wafer should have a baseline radius measurement. A positive radius indicates tensile stress and a negative radius indicates compressive stress. Wafer bow can be calculated, as shown in Figure 14, by measuring the maximum point of deflection from the chord connecting the end-points of a scan of Flux apparatus 1300.

[094] Measurements of stress performed on several embodiments of barrier films 1203 where barrier film 1203 is a 92-8 film as discussed above with and without a nucleation layer 1202 formed by a soft-metal breath treatment is tabulated in Table 2. As shown in Table 2, sample 1 was a 1.5 KÅ 92-8 film of actual thickness 1760 Å deposited on a Si-Wafer substrate. The resulting stress at about room temperature was -446.2 MPa. Sample 2 was a 1.5 KÅ 92-8 film of actual thickness 1670 Å over an Al-breath deposition resulted in a stress of about -460.2 MPa. In sample 3, a 1.5 KÅ 92-8 film of thickness 1860 Å was deposited subsequent to a In-breath deposition and resulted in a stress of -330.2 MPa, nearly 100 MPa lower than either of the other two depositions depicted.

1, sample 2, and sample 3 as shown in Table 1 over a temperature cycle. The temperature cycle included heating from room temperature to about 160 °C and cooling back to room temperature. In a Si-Wafer substrate, the radius of the wafer is assumed not to change with temperature. Stress data in each case was taken at the temperature indicated. As can be seen from Figure 15, 92-8 films deposited over an In-breath treatment exhibited much less stress than did either a 92-8 film deposited over an Al-breath treatment or a 92-8 film deposited over the substrate without a soft-metal breath treatment.

[096] Atomic-force microscopy (AFM) can be utilized to measure surface roughness of a film. In AFM, a miniature probe is physically scanned over the surface of a film such that the probe is in contact, and follows the surface, of the film. The probe has a small tip and therefore is capable of accurately monitoring the surface roughness for features on the order of a few nanometers.

[097] Figure 16A shows the surface roughness of a PEN substrate (Dupont Teijin PEN films 200  $\mu\text{m}$  thickness), before deposition of a barrier layer according to the present invention. As is shown in Figure 16A, a PEN substrate typically has a surface roughness of average 2.2 nm, root-mean-square average RMS of 3.6 nm, and a typical maximum roughness of about 41.0 nm. As shown in Figure 16B, deposition of a 1.5 K $\text{\AA}$  92-8 after an indium-tin breath treatment on a PEN substrate results in an average surface roughness of 1.0 nm with RMS roughness of 1.7 nm and maximum roughness of 23.6 nm. As is shown in Figure 16C, an indium-tin-oxide (ITO) breath treatment was performed before the 1.5 K $\text{\AA}$  92-8 barrier layer film deposition

resulted in an average roughness of 2.1 nm with RMS roughness of 3.4 nm and maximum roughness of 55.4 nm. The deposition shown in Figure 16C is performed with a 125  $\mu\text{m}$  PEN substrate rather than a 200  $\mu\text{m}$  PEN substrate. Therefore, a direct ITO treatment does not perform as well as treatment with an indium-tin breath. As shown in Figure 16D, deposition of a barrier layer of 1.5 K  $\text{\AA}$  directly on a 125  $\mu\text{m}$  PEN substrate resulted in a barrier layer with average surface roughness of about 5.2 nm with RMS roughness of 8.5 nm and maximum roughness of 76.0 nm. Therefore, although the ITO breath treatment was better than no soft-metal treatment at all with respect to surface roughness, an indium-tin breath treatment resulted in the best surface roughness yielding an average surface roughness of about 1.0 nm.

[098] Figure 17 illustrates a water vapor transmission (WVTR) testing apparatus 1700 that can be utilized to characterize barrier layer films according to embodiments of the present invention. A sample 1701 can be mounted into apparatus 1700 in such a way that the surface of substrate 1201 (Figure 12) is isolated from the surface of barrier layer 1203 (Figure 12). A moisture-free gas is input to port 1702, contacts one surface of sample 1701, and is directed to sensor 1703 where the water vapor coming from sample 1701 is monitored. A humid gas is directed to the opposite side of sample 1701 through port 1705. An RH probe 1704 can be utilized to monitor the water content of the gas input to port 1705. Sensor 1703, then, monitors the water vapor that is transmitted through sample 1701.

[099] Such tests are performed by Mocon Testing Service, 7500 Boone Avenue North, Minneapolis, MN 55428. In addition, the Mocon testing is performed in accordance with ASTM F1249 standards. Typically, instruments

utilized for WVTR testing by Mocon can detect transmission in the range 0.00006gm/100in<sup>2</sup>/day to 4gm/100in<sup>2</sup>/day. The Mocon 3/31 instrument, for example, has a lower detection limit of about 0.0003gm/100in<sup>2</sup>/day.

[0100] A barrier layer deposition formed with an Al-breath treatment followed by a 1.5 K Å 92-8 barrier layer deposition on a 200 µm PEN substrate resulted in a Mocon test WVTR of 0.0631 gm/100in<sup>2</sup>/day. A barrier layer deposition formed with an In-breath treatment followed by a 1.5 K Å 92-8 on 200 µm PEN substrate resulting in no measurable WVTR in the Mocon 3/31 instrument (i.e., the transmission rate was less than 0.0003 gm/100in<sup>2</sup>/day).

[0101] As was further discussed above, Figures 16A through D illustrates the role that a soft-metal breath treatment (in particular an indium breath treatment) can play in determining the surface roughness of a deposited barrier layer according to the present invention. The surface roughness of a barrier layer can also affect the WVTR characteristics of a barrier layer. Smoother barrier layer result in better WVTR performance. As such, Figure 16A shows a bare 200 µm PEN substrate with no barrier. Figure 16B shows a 200 µm PEN substrate with a 1500 Å thickness 92-8 barrier layer deposited after a In/Sn breath treatment according to the present invention. Figure 16C illustrates a 200 µm PEN substrate with a 1500 Å 92-8 barrier layer deposited after treatment with ITO breath. Figure 16D is a 200 µm PEN substrate with a 1500 Å 92-8 barrier layer directly deposited on the substrate. As can be seen, the structure of Figure 16B shows the best surface smoothness characteristics.

[0102] Table 3 illustrates several examples of barrier layers, with surface smoothness characteristics and MOCON WVTR testing results. In Table 3, the samples described in rows 1-4 are 92-8 layers (as described above) of thickness about 2000 Å deposited on one or both sides of a 700 µm thick polycarbonate (LEXAN produced by General Electric, corp.). The data shows that the double-side coated barrier layer structure (rows 1 and 2) perform about an order of magnitude better in MOCON WVTR test than does the one sided structures (rows 3 and 4).

[0103] Rows 5 through 8 illustrate various deposition on a PEN substrate (with rows 5-6 describing deposition on a 200 µm PEN substrate and rows 7 and 8 describing depositions on a 125 µm PEN substrate). The In breath treatment parameters refer to In/Sn breath treatments as discussed above. The AFM parameters are shown in Figures 16B through 16D as described earlier. As discussed before, the best surface smoothness and the best WVTR characteristics are shown in row 6, with In breath treatment followed by deposition of a 92-8 layer. The data in row 9 indicates an In breath treatment (In/Sn) with higher power on a thinner (125 µm) PEN substrate. Presumably, the thermal stress behavior on a 125 µm PEN substrate is worse than that for a 200 µm PEN substrate. Further indication of this effect is shown in the data of rows 30 through 33 along with Figures 19A and 19B. The data in rows 30 and 31 include a indium/tin breath treatment (at 750W) on a 200 µm PEN substrate followed by about 1.5 kÅ 92-8 layer deposition, which yields a very smooth surface (e.g., about 1.1nm average) as shown in Figure 19A and an undetectable MOCON WVTR characteristic on the MOCON 3/31 test equipment. The data in rows 32 and 33, with In/Sn breath treatment followed by 1.5 kÅ 92-8 layer deposition

on 125  $\mu\text{m}$  PEN substrate, shows worse smoothness (about 2.0 nm average roughness) and a WVTR test in the MOCON apparatus of about  $1.7 \times 10^{-2}$   $\text{gm}/\text{m}^2/\text{day}$ . The 92-8 depositions illustrated in rows 30 through 33 were concurrently performed in a single operation.

[0104] The data in rows 12 and 13 of Table 3 indicate an In-breath treatment plus 1.5  $\text{k}\text{\AA}$   $\text{TiO}_2$  deposition on a 125  $\mu\text{m}$  PEN substrate. Data in rows 10 and 11 indicate an In/Sn-breath treatment plus 1.5  $\text{k}\text{\AA}$  92-8 deposition on a 125  $\mu\text{m}$  PEN substrate. As can be seen in Table 3, the WVTR characteristics of 92-8 layers is more than an order of magnitude better than the WVTR characteristics of  $\text{TiO}_2$  layers. Representative smoothness for rows 12 and 13 are presented in Figure 22A and representative smoothness for rows 10 and 11 are presented in Figure 22B. As is shown in Table 3, the average smoothness for 92-8 layers is approximately an order of magnitude better than the average smoothness for  $\text{TiO}_2$ .

[0105] The data in rows 14 and 15 of Table 3 illustrate an In/Sn breath treatment on a 125  $\mu\text{m}$  LEXAN substrate followed by a 92-8 layer deposition. The data in rows 14 and 15 can be compared with the data in rows 32 and 33, which are In/Sn breath treatment on a 125  $\mu\text{m}$  PEN substrate followed by a 1.5  $\text{k}\text{\AA}$  92-8 layer deposition. The smoothness is comparable between the LEXAN and PEN substrate, although as can be seen in a comparison of Figures 21A and 21B, the morphology is different, i.e. barrier layers according to the present invention deposited on the LEXAN substrate show more granularity than barrier layers deposited on the PEN substrate.



[0106] The data in rows 16 through 18 of Table 3 illustrate different process parameters for an In/Sn breath treatment followed by 1.5 kÅ 92-8 deposition on a 200 µm PEN substrate. The data in row 16 illustrates a setting where the current is set rather than power. The data in row 16 is taken with a current of 6.15 amps. In the barrier layer illustrated in row 17, the In/Sn breath treatment is performed at 1.5 kW of operating power. In the barrier layer illustrated in row 18, the In/Sn breath treatment is performed at 750 W of operating power. In each case, the MOCON WVTR characteristic of the resulting barrier layer is below detectability on the MOCON 3/31 instrument.

[0107] The data in rows 19-29 of Table 3 illustrate different In/Sn breath treatments and their effects on the surface smoothness of the resulting barrier layers and on the MOCON WVTR characteristics. The data in rows 19-22 are all examples of where the In/Sn breath treatment is replaced with a evaporated In layer followed by a 130 C preheat treatment. The surface roughness characteristics are illustrated in Figure 18A and shows an average roughness of about 1.1 nm. However, the morphology is very granular as is shown in Figure 18A, with presumably a lot of porosity, resulting in MOCON WVTR test on the order of .8 gm/m<sup>2</sup>/day. The data shown in row 23 of Table 3 illustrates the case where no In/Sn breath treatment is utilized and the 200 µm PEN substrate is preheated before deposition of a 1.5 kÅ 92-8 deposition, which as shown in Figure 18C has a surface roughness of about 5.2 nm average and a MOCON WVTR of about 0.8 gm/m<sup>2</sup>/day, or the same as is shown with the indium evaporation vapor data shown in rows 19-22. Therefore, the same characteristics result whether an indium evaporation vapor treatment is applied or not.

[0108] Rows 24-29 of Table 3 illustrate data where an In/Sn breath treatment was performed at 280 °C rather than at room temperature. The surface roughness, as is illustrated in Figure 18B, was about 1.1 nm average. However, the MOCON WVTR data was about  $3 \times 10^{-2}$  gm/m<sup>2</sup>/day. This value is much higher than that shown in the similar depositions of rows 30 and 31, which were below  $5 \times 10^{-3}$  gm/m<sup>2</sup>/day detectability limits of the MOCON 3/31 instrument.

[0109] The data in rows 34 and 35 illustrates deposition of a 1.5 kÅ 35-65 layer (i.e., a deposition with a target having 35% Si and 65 % Al) following a In/Sn deposition on a 200 μm PEN substrate. As is illustrated, the MOCON WVTR are  $1.4 \times 10^{-1}$  gm/m<sup>2</sup>/day, which shows the possible necessity of a biased process for producing barrier layers according to the present invention.

[0110] Figure 20 illustrates a barrier layer 2002 that can also operate as a thin film gate oxide deposited on a substrate 2001. A thin film gate oxide 2002 can be deposited as a barrier layer according to the present invention. Such a layer as the benefit of protecting moisture and oxygen sensitive transistor layer compounds of germanium, tin oxide, zinc oxide, or pentacene, for example, while functioning as the thin oxide electrical layer. Substrate 2001 can include any electrical device that can be formed on, for example, a silicon wafer, plastic sheet, glass plate, or other material. Barrier layer 2002 can be a thin layer, for example from 25 to 500 Å.

[0111] Titanium oxide is well known as the preferred material for biological implantation due to the lack of immunological response to titanium oxide. In addition, it is preferred that a thin film of TiO<sub>2</sub>, which is an immunologically indifferent barrier layer, can simultaneously protect a device such as a voltage or

charge sensor or an optical device such as a waveguide while performing the role of coupling the device capacitively or optically due to its' high dielectric constant or its' high optical index.

[0112] An array of capacitors can be coupled by the high capacitive density due to the proximity of the sensor provided by a very thin high-k dielectric such as TiO<sub>2</sub>. In practice, a micron or sub micron array can be used to monitor the electrical activity, amplitude, and direction of very low electrical signals such as those that accompany the propagation of electrical signals in single axion of single neural ganglia. Conversely, it can also be used to electrically couple stimulus to adjacent cells or tissue. High resolution, high-capacitance coupling to the optic nerve, the auditory nerve, or neural tissue on the order of 5 to 50 femto-farads/ $\mu\text{m}^2$  is made uniquely feasible by such a capacitive barrier film without immunological reaction.

[0113] Other embodiments of the invention will be apparent to those skilled in the art from consideration of the specification and practice of the invention disclosed herein. This disclosure is not limited by any theories or hypothesis of operation that are utilized to explain any results presented. It is intended that the specification and examples be considered as exemplary only, with a true scope and spirit of the invention being indicated by the following claims. As such, this application is limited only by the following claims.

TABLE 1

Stack #	Substrates	Stack layer composition	TiO <sub>2</sub> Deposition Process	Measured Thickness TiO <sub>2</sub> (Å)	Silica/alumina (92-8) Deposition Process	Measured Thickness Silica/Alumina (92-8) (Å)
1	6 Microscope slides + 1 6inch wfr	TiO <sub>2</sub> /92-8/ TiO <sub>2</sub> /92-8/ TiO <sub>2</sub>	7KW/200W/200KHz/60Ar /90O2/950s	580	3KW/200W/200KHz/85Ar /90O2/1005	980
2	6 Microscope slides + 1 6inch wfr	TiO <sub>2</sub> /92-8/ TiO <sub>2</sub> /92-8/ TiO <sub>2</sub>	7KW/200W/200KHz/60Ar /90O2/835s	510	3KW/200W/200KHz/85Ar /90O2/1006	910
3	2 Sodalime Glass + 4 Microscope Slides	TiO <sub>2</sub> /92-8/ TiO <sub>2</sub> /92-8/ TiO <sub>2</sub>	7KW/200W/200KHz/60Ar /90O2/901s	550	3KW/200W/200KHz/85Ar /90O2/1025	1000
4	2 Sodalime Glass + 4 Microscope Slides	TiO <sub>2</sub> /92-8/ TiO <sub>2</sub> /92-8/ TiO <sub>2</sub>	7KW/200W/200KHz/60Ar /90O2/901s	550	3KW/200W/200KHz/85Ar /90O2/1025	1000
5	4 Microscope Slides	TiO <sub>2</sub> /92-8/ TiO <sub>2</sub> /92-8	7KW/200W/200KHz/60Ar /90O2/901s	550	3KW/200W/200KHz/85Ar /90O2/1025	1000
6	3 Sodalime Glass + 4 Microscope Slides	TiO <sub>2</sub> /92-8/ TiO <sub>2</sub> /92-8/ TiO <sub>2</sub>	7KW/200W/200KHz/60Ar /90O2/901s	550	3KW/200W/200KHz/85Ar /90O2/1025	1000

TABLE 2

<b>Id</b>	<b>Comment</b>	<b>Temp °C</b>	<b>Radius (m)</b>	<b>Stress Mpa</b>	<b>Film Thickness (Å)</b>	<b>Bow (µm)</b>
Sample 1	pre-deposition	21	-4.76E+03	N/A	N/A	1.58
	1.5 KÅ 92-8 film deposition/ no In-breath treatment	27	-145.978	-446.2	1760	11.74
Sample 2	pre-deposition	29	-4.10E+03	N/A	N/A	1.38
	Al breath deposition then 1.5 KÅ 92-8 film treatment	36	-169.482	-460.2	1670	10.18
Sample 3	pre-deposition	25	-230.249	N/A	N/A	4.36
	In breath treatment then 1.5 KÅ 92-8 film deposition	25	-67.169	-330.2	1860	10.25

TABLE 3

Sample ID	Sample Description	Substrate Material	Thickness $\mu\text{m}$	MOCON WVTR (g/100inch <sup>2</sup> /day)	MOCON WVTR (g/m <sup>2</sup> /day)	AFM Results
1 (Film (coated on both sides) - A)	2 KÅ 92-8 on Polycarbonate, deposited on both sides-A	LEXAN	700	7.2000E-04	1.1160E-02	
2 (Film (coated on both sides) - B)	2 KÅ 92-8 on Polycarbonate, deposited on both sides-B	LEXAN	700	5.8000E-04	8.9900E-03	
3 (Film (coated on one side) - A)	2 KÅ 92-8 on Polycarbonate - A	LEXAN	700	8.3000E-03	1.2865E-01	
4 (Film (coated on one side) - B)	2 KÅ 928 on Polycarbonate - B	LEXAN	700	1.7200E-02	2.6660E-01	
5 (Al+1.5K928)	Al -breath (500W 10sec+ 130c heat treatment) + 1.5 KÅ 92-8 on PEN	PEN Q65	200	6.3100E-02	9.7805E-01	

6 (InB + 1.5K928)	In Breath (750W 5sec+ 130c heat treatment) + 1.5 KÅ 92-8 on PEN	PEN Q65	200	3.0000E-04	4.6500E-03	Ra=1.3nm RMS=1.5nm Rmax=9.8nm See Figure 16B
7 (102-MOCON ID: 1619-003)	NO In Breath + 130c Preheat + 1.5 KÅ 92-8 on PEN	PEN Q65	125	4.0200E-02	6.2310E-01	Ra=5.2nm RMS=8.5nm Rmax=76.0nm See Figure 16D
8 (103-MOCON ID: 1619-002)	ITO breath + 130c Preheat + 1.5 KÅ 92-8 on PEN	PEN Q65	125	2.4900E-02	3.8595E-01	Ra=2.1nm RMS=3.4nm Rmax=55.5nm See Figure 16C
9 (104-MOCON ID: 1619-001)	In Breath (1.5KW + 130c Preheat) + 1.5 KÅ 92-8 on PEN	PEN Q65	125	2.5900E-02	4.0145E-01	
10 (PEN-A)	In Breath+92-8 on PEN	PEN Q65	125	1.8323E-03	2.8400E-02	Ra=3.4nm, RMS=4.2nm Rmax=29.4nm See Figure 22B
11 (PEN-B)	In Breath+92-8 on PEN	PEN Q65	125	2.3871E-03	3.7000E-02	Ra=3.4nm RMS=4.2nm Rmax=29.4nm See Figure 22B

12 (PEN2-A)	In Breath+TiO2 on PEN	PEN Q65	125	1.0065E-01	1.56	Ra=7.7nm RMS=9.7nm Rmax=72.4nm See Figure 22A
13 (PEN2-B)	In Breath+TiO2 on PEN	PEN Q65	125	8.9032E-02	1.38	Ra=7.7nm RMS=9.7nm Rmax=72.4nm See Figure 22A
14 (LEXAN-A)	InB+92-8 on LEXAN	LEXAN	125	1.4194E-02	2.2000E-01	Ra=0.9nm RMS=1.1nm Rmax=9.5nm See Figure 21A
15 (LEXAN-B)	In Breath+92-8 on LEXAN	LEXAN	125	2.8387E-03	4.4000E-02	Ra=0.9nm RMS=1.1nm Rmax=9.5nm See Figure 21A
16 (6.15A)	In Breath (6.15A 5sec+ 130 °C heat) + 1.5 KÅ 92-8 on PEN	PEN Q65 Lot#1	200	Below Detection	Below Detection	
17 (1.5KW)	In Breath (1.5KW 5sec+ 130 °C heat) + 1.5 KÅ 92-8 on PEN	PEN Q65 Lot#1	200	Below Detection	Below Detection	



18 (750W)	In Breath (750W 5sec+ 130 °C heat) + 1.5 KÅ 92-8 on PEN	PEN Q65 Lot#1	200	Below Detection	Below Detection	
19 (.037-A)	In Breath from Evap 0.037 + 130 °C Preheat + 1.5 KÅ 92-8 on PEN	PEN Q65 Lot#1	200	5.1097E-02	7.9200E-01	Ra=1.1nm RMS=1.4nm Rmax=9.4nm See Figure 18A
20 (.037-B)	In Breath from Evap 0.037 + 130 °C Preheat + 1.5 KÅ 92-8 on PEN	PEN Q65 Lot#1	200	3.9935E-02	6.1900E-01	Ra=1.1nm RMS=1.4nm Rmax=9.4nm See Figure 18A
21 (.113-A)	In Breath from Evap 0.113 + 130 °C Preheat + 1.5 KÅ 92-8 on PEN	PEN Q65 Lot#1	200	5.6323E-02	8.7300E-01	Ra=1.1nm RMS=1.4nm Rmax=9.4nm See Figure 18A
22 (.113-B)	In Breath from Evap 0.113 + 130 °C Preheat + 1.5 KÅ 92-8 on PEN	PEN Q65 Lot#1	200	4.1097E-02	6.3700E-01	Ra=1.1nm RMS=1.4nm Rmax=9.4nm See Figure 18A
23 (MON-A)	NO In Breath + 130 °C heat + 1.5 KÅ 92-8 on PEN	PEN Q65 Lot#1	200	4.9806E-02	7.7200E-01	Ra=5.2nm RMS=8.5nm Rmax=76.0nm See Figure 18C

24 (12-17-03-01-A)	In Breath @280c+ 130 °C heat + 1.5 KÅ 92-8 on PEN	PEN Q65 Lot#1	200	7.8710E-04	1.2200E-02	Ra=1.1nm, RMS=1.4nm Rmax=9.4nm See Figure 18B
25 (12-17-03-01-B)	In Breath @280c+ 130 °C heat + 1.5 KÅ 92-8 on PEN	PEN Q65 Lot#1	200	1.1484E-03	1.7800E-02	Ra=1.1nm RMS=1.4nm Rmax=9.4nm See Figure 18B
26 (12-17-03-03-A)	In Breath @280c+ 130 °C heat + 1.5 KÅ 92-8 on PEN	PEN Q65 Lot#1	200	1.9548E-03	3.0300E-02	Ra=1.1nm RMS=1.4nm Rmax=9.4nm See Figure 18B
27 (12-17-03-03-B)	In Breath @280c+ 130 °C heat + 1.5 KÅ 92-8 on PEN	PEN Q65 Lot#1	200	1.1935E-03	1.8500E-02	Ra=1.1nm RMS=1.4nm Rmax=9.4nm See Figure 18B
28 (12-17-03-02 A)	In Breath @280c+ 130 °C heat + 1.5 KÅ 92-8 on PEN	PEN Q65 Lot#1	200	2.2065E-03	3.4200E-02	Ra=1.1nm RMS=1.4nm Rmax=9.4nm See Figure 18B
29 (12-17-03-02 B)	In Breath @280c+ 130 °C heat + 1.5 KÅ 92-8 on Pen	PEN Q65 Lot#1	200	2.7677E-03	4.2900E-02	Ra=1.1nm RMS=1.4nm Rmax=9.4nm See Figure 18B

30 (165-A)	InB 750W 5sec+4300 130c Preheat + 1.5KA 92-8 on PEN	PEN Q65 Lot#2	200	Below Detection	Below Detection	Ra=1.1nm RMS=1.4nm Rmax=9.4nm  See Figures 19A and 18D
31 (165-B)	In Breath (750W 5sec+130 °C heat) + 1.5 KÅ 92-8 on PEN	PEN Q65 Lot#2	200	Below Detection	Below Detection	Ra=1.1nm RMS=1.4nm Rmax=9.4nm  See Figures 19A and 18D
32 (167-A)	In Breath (750W 5sec+ 130 °C heat) + 1.5 KÅ 92-8 on PEN	PEN Q65 Lot#2	125	9.0323E-04	1.4000E-02	Ra=2.0nm RMS=2.6nm Rmax=18.0nm  See Figures 19B and 21B
33 (167-B)	In Breath (750W 5sec+ 130 °C heat) + 1.5 KÅ 92-8 on PEN	PEN Q65 Lot#2	125	1.4194E-03	2.2000E-02	Ra=2.0nm RMS=2.6nm Rmax=18.0nm  See Figures 19B and 21B
34 (170-A)	In Breath (750W 5sec+130 °C heat) + 1.5 KÅ 35-65 (no bias) on PEN	PEN Q65 Lot#2	125	8.7742E-03	1.3600E-01	
35 (170-B)	In Breath (750W 5sec+130 °C heat) + 1.5 KÅ 35-65 (no Bias) on PEN	PEN Q65 Lot#2	125	2.6258E-02	4.0700E-01	

TABLE 4

	H <sub>v</sub> [Vickers]	H [MPa]	E [GPa]	□ d [□m]
MN-Al <sub>2</sub> O <sub>3</sub> 5mN	1 836	19 814	211.49	0.129
MN-Al <sub>2</sub> O <sub>3</sub> 2.5mN	2 087	22 520	230.51	0.084
Y10822-1 5 mN	753	8 123	104.03	0.194
808-0Y10822-1 2.5 mN	834	8 996	104.29	0.130

WHAT IS CLAIMED IS:

1. A dielectric layer, comprising:  
a densified amorphous dielectric layer deposited on a substrate by pulsed-DC, substrate biased physical vapor deposition,  
wherein the densified amorphous dielectric layer is a barrier layer.
2. The layer of claim 1, wherein the deposition is performed with a wide area target.
3. The layer of claim 1, wherein the barrier layer is also an optical layer.
4. The layer of claim 3, wherein the barrier layer includes a TiO<sub>2</sub> layer.
5. The layer of claim 3, wherein the barrier layer includes an Alumina/Silica layer.
6. The layer of claim 3, further including a soft-metal breath treatment.
7. The layer of claim 6, wherein the soft-metal breath treatment is an indium-tin vapor treatment.
8. The layer of claim 1, wherein the barrier layer is also an electrical layer.
9. The layer of claim 8, wherein the barrier layer includes a capacitive layer.
10. The layer of claim 9, wherein the capacitive layer is a TiO<sub>2</sub> layer.
11. The layer of claim 9, wherein the capacitive layer is an Alumina/silica layer.
12. The layer of claim 8, wherein the barrier layer includes a resistive layer.
13. The layer of claim 12, wherein the resistive layer is indium-tin metal or oxide.
14. The layer of claim 8, further including a soft-metal breath treatment.
15. The layer of claim 14, wherein the soft-metal breath treatment is an indium-tin vapor treatment.
16. The layer of claim 1, wherein the barrier layer includes a tribological layer.
17. The layer of claim 16, wherein the tribological layer is a TiO<sub>2</sub> layer.

18. The layer of claim 16, wherein the tribological layer is Alumina/silica.
19. The layer of claim 16, further including a soft-metal breath treatment.
20. The layer of claim 19, wherein the soft-metal breath treatment is an indium-tin vapor treatment.
21. The layer of claim 1, wherein the barrier layer is a biologically immune compatible layer.
22. The layer of claim 1, wherein the biologically immune compatible layer is  $\text{TiO}_2$ .
23. The layer of claim 21, further including a soft-metal breath treatment.
24. The layer of claim 23 wherein the soft-metal breath treatment is an indium-tin vapor treatment.
25. The layer of claim 1, wherein the dielectric film is  $\text{TiO}_2$ .
26. The layer of claim 1, wherein a target utilized to form the dielectric film has a concentration of 92% Al and 8% Si.
27. The layer of claim 1, wherein the target utilized to form the dielectric film is formed from metallic magnesium.
28. The layer of claim 1, wherein the target material comprises materials chosen from a group consisting of Mg, Ta, Ti, Al, Y, Zr, Si, Hf, Ba, Sr, Nb, and combinations thereof.
29. The layer of claim 28, wherein the target material includes a concentration of rare earth metal.
30. The layer of claim 1, wherein the target material comprises a sub-oxide of a group consisting of Mg, Ta, Ti, Al, Y, Zr, Si, Hf, Ba, Sr, Nb, and combinations thereof.
31. The layer of claim 1, further including a soft-metal breath treatment.

32. The layer of claim 31, wherein the soft-metal breath treatment is an indium-tin vapor treatment.
33. The layer of claim 1, wherein the dielectric film has a permeable defect concentration of less than about 1 per square centimeter.
34. The layer of claim 1, wherein the water vapor transmission rate is less than about  $1 \times 10^{-2}$  gm/m<sup>2</sup>/day.
35. The layer of claim 1, wherein the optical attenuation is less than about 0.1 dB/cm in a continuous film.
36. The layer of claim 1, wherein the barrier layer has a thickness less than about 500 nm.
37. The layer of claim 36, wherein the water vapor transmission rate is less than about  $1 \times 10^{-2}$  gm/m<sup>2</sup>/day.
38. The layer of claim 1, wherein the barrier layer thickness is less than about 1 micron and the water vapor transmission rate is less than about  $1 \times 10^{-2}$  gm/m<sup>2</sup>/day.
39. The layer of claim 1, wherein the barrier layer operates as a gate oxide for a thin film transistor.
40. A method of forming a barrier layer, comprising:
- providing a substrate;
  - depositing a highly densified, amorphous, dielectric material over the substrate in a pulsed-DC, biased, wide target physical vapor deposition process.
41. The method of claim 40, further including
- performing a soft-metal breath treatment on the substrate.
42. The method of claim 40, wherein the dielectric material is formed from a target comprising 92% Al and 8% Si.

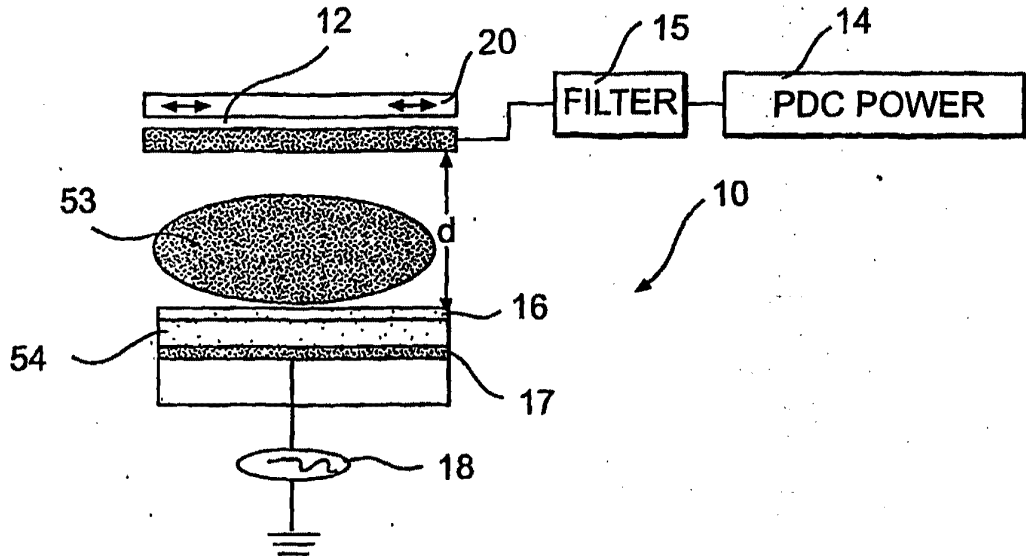
43. The method of claim 40, wherein the dielectric material is formed from a target comprising of Titanium.

44. The method of claim 40, wherein the dielectric material is formed from a target material comprising materials chosen from a group consisting of Mg, Ta, Ti, Al, Y, Zr, Si, Hf, Ba, Sr, Nb, and combinations thereof.

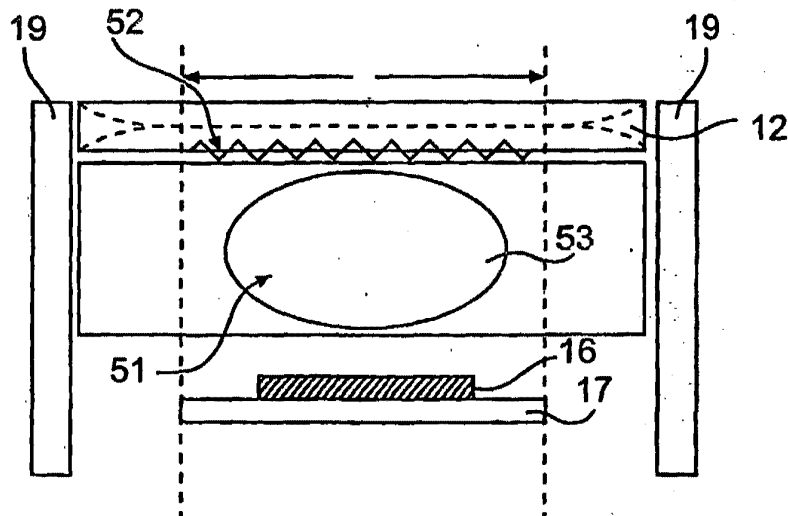
45. The method of claim 41, wherein the soft-metal breath treatment is an indium/tin breath treatment.



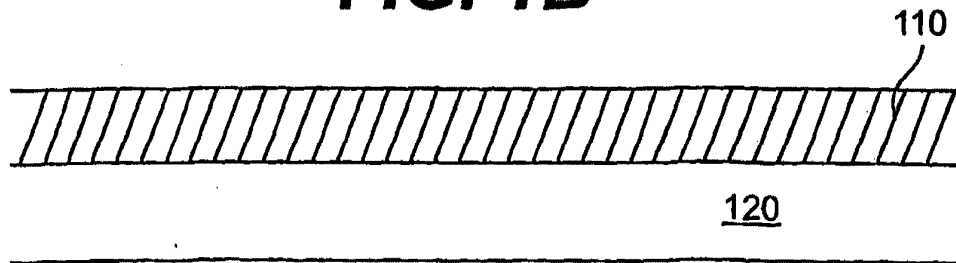
1/20



**FIG. 1A**



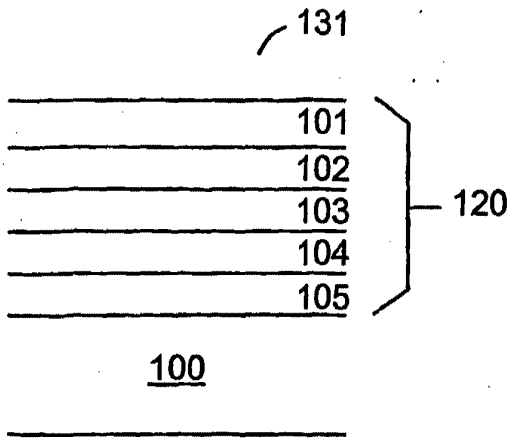
**FIG. 1B**



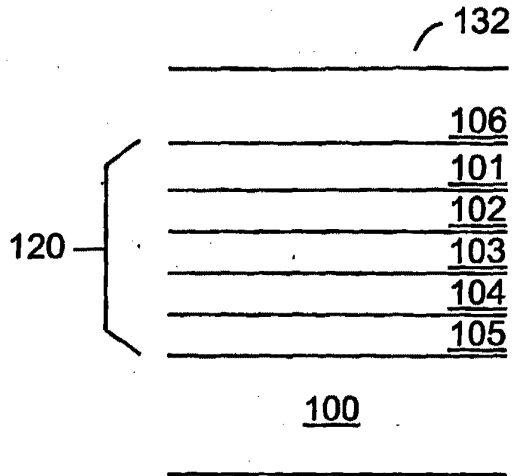
**FIG. 1C**

SUBSTITUTE SHEET (RULE 26)

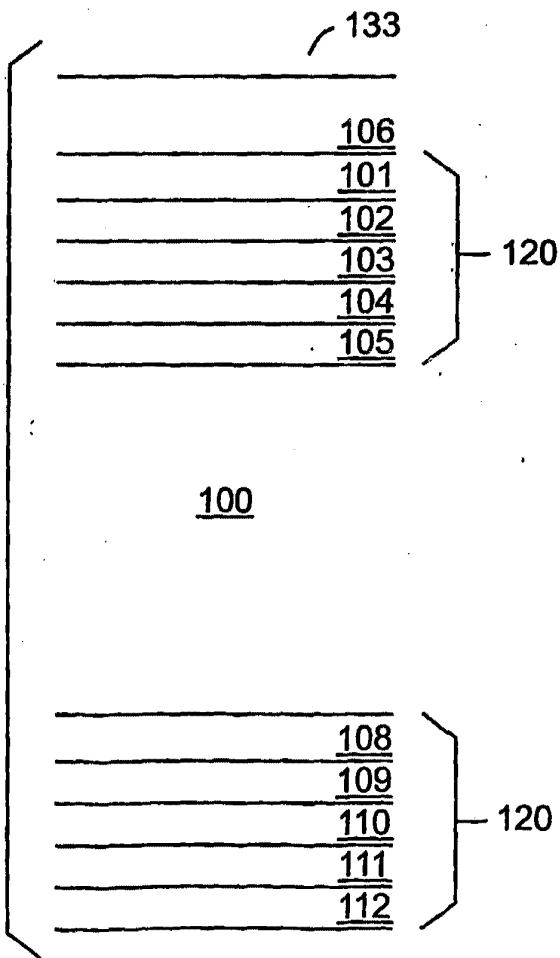
2/20



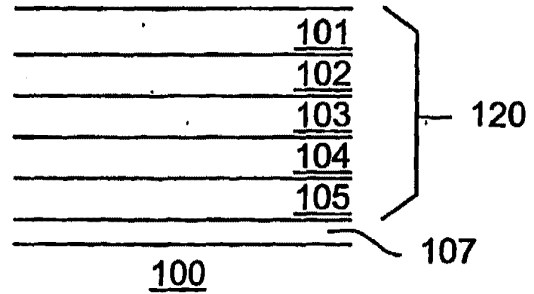
**FIG. 2A**



**FIG. 2B**



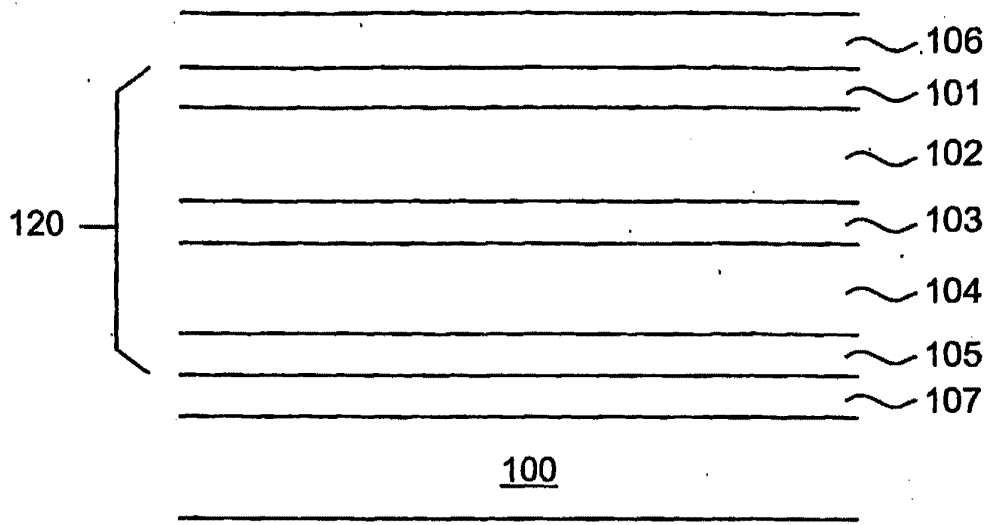
**FIG. 2C**



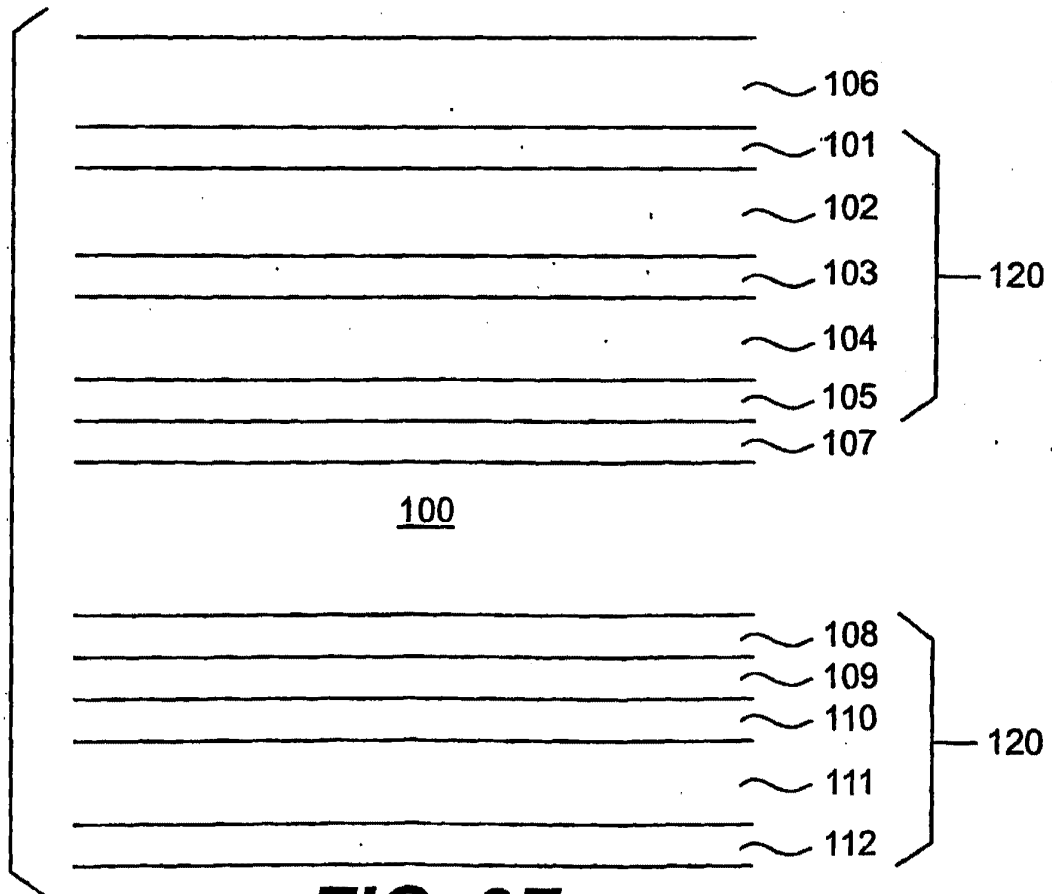
**FIG. 2D**

SUBSTITUTE SHEET (RULE 26)

3/20



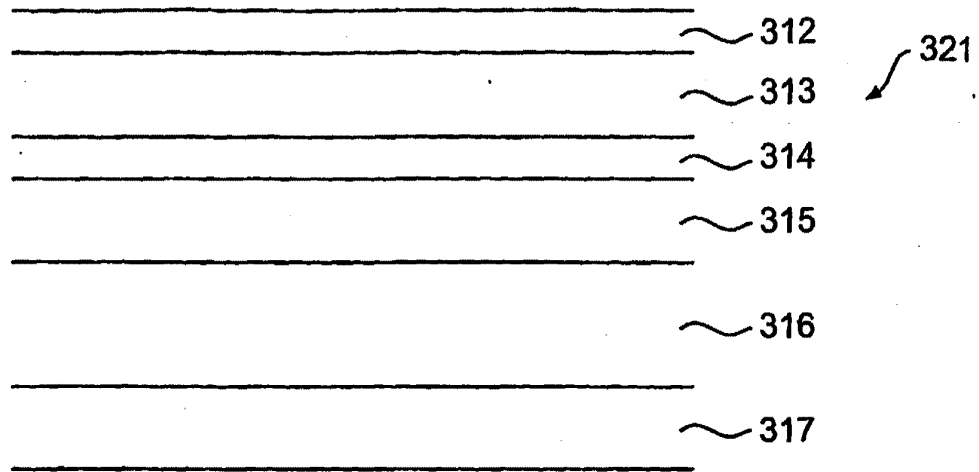
**FIG. 2E**



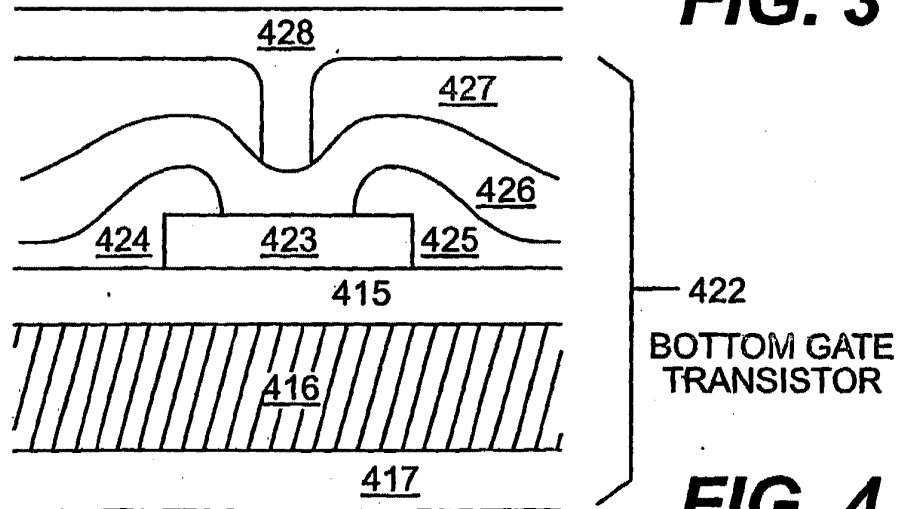
**FIG. 2F**

SUBSTITUTE SHEET (RULE 26)

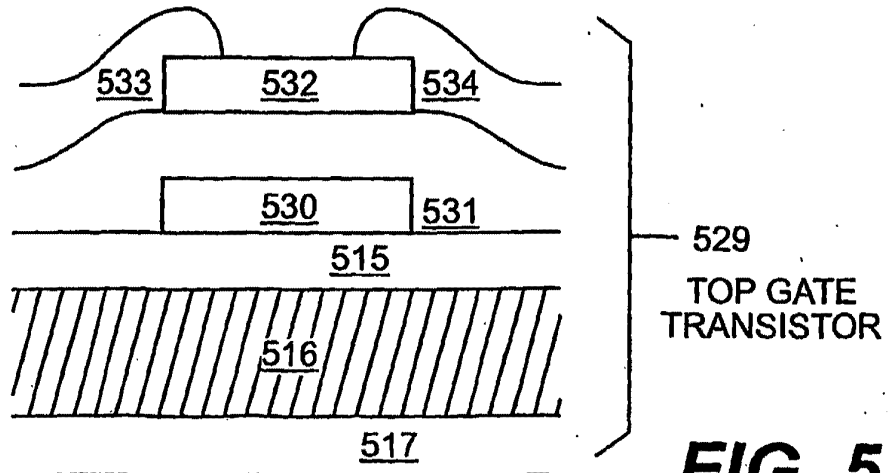
4/20



**FIG. 3**



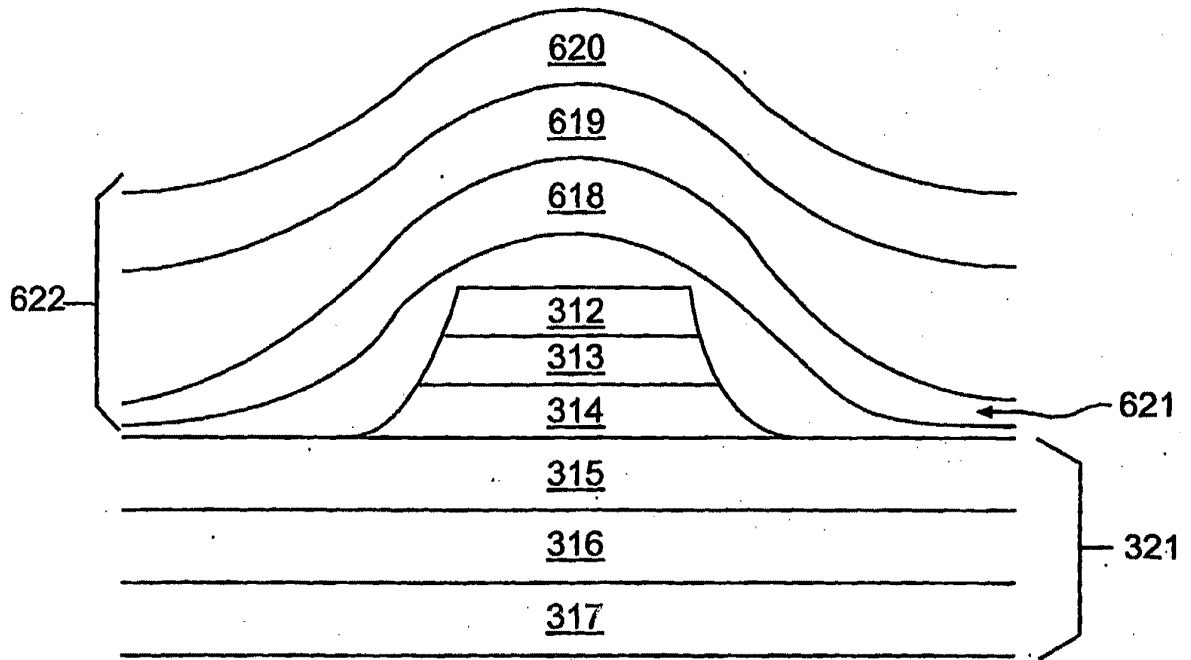
**FIG. 4**



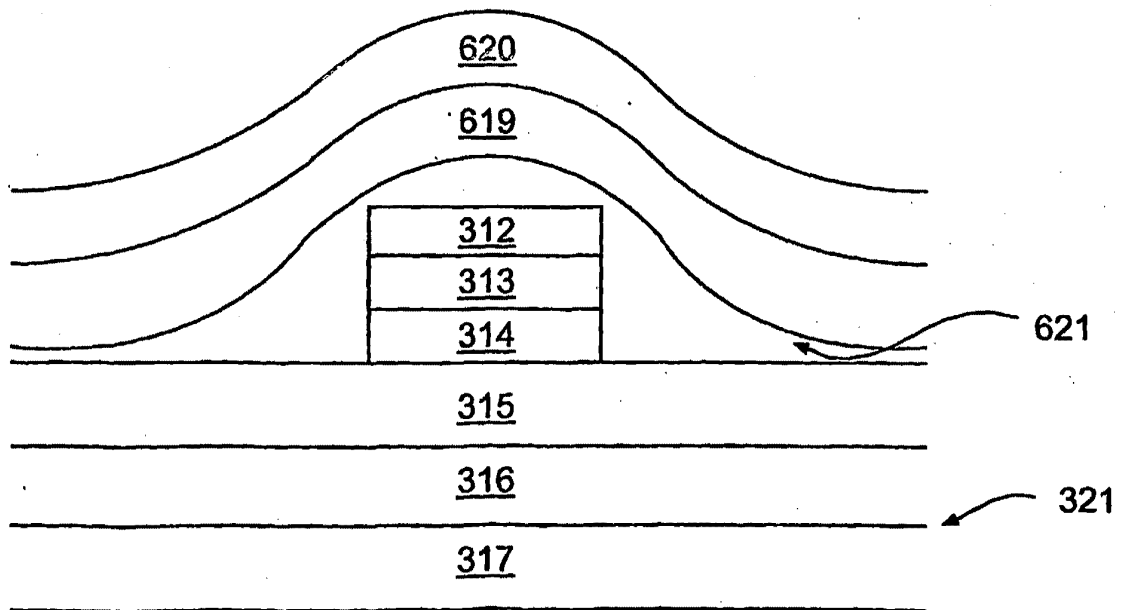
**FIG. 5**

SUBSTITUTE SHEET (RULE 26)

5/20



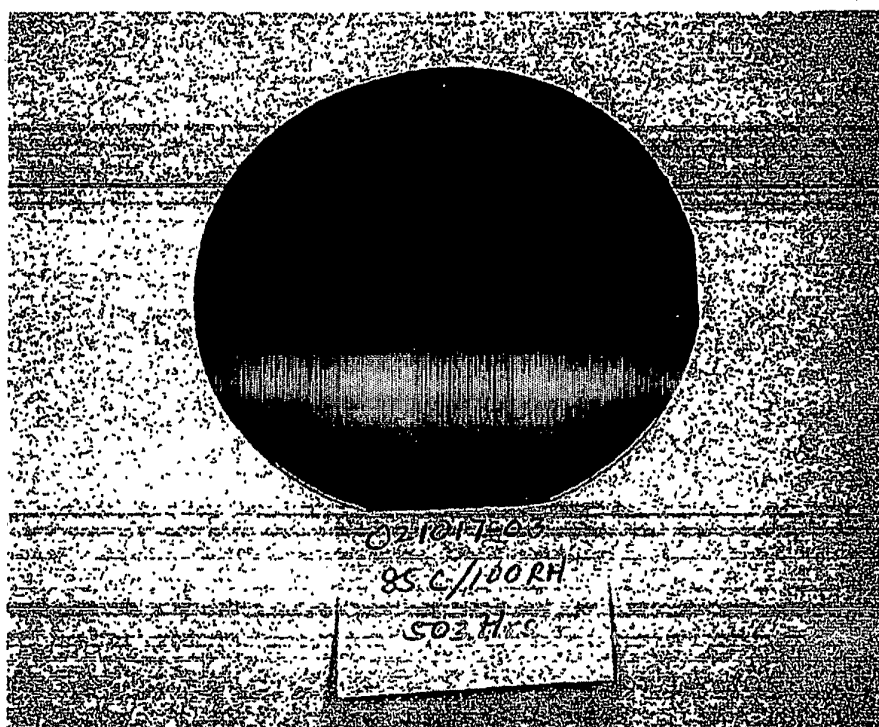
**FIG. 6**



**FIG. 7**

SUBSTITUTE SHEET (RULE 26)

6/20



**FIG. 8**

SUBSTITUTE SHEET (RULE 26)

7/20



**FIG. 9**

SUBSTITUTE SHEET (RULE 26)

8/20

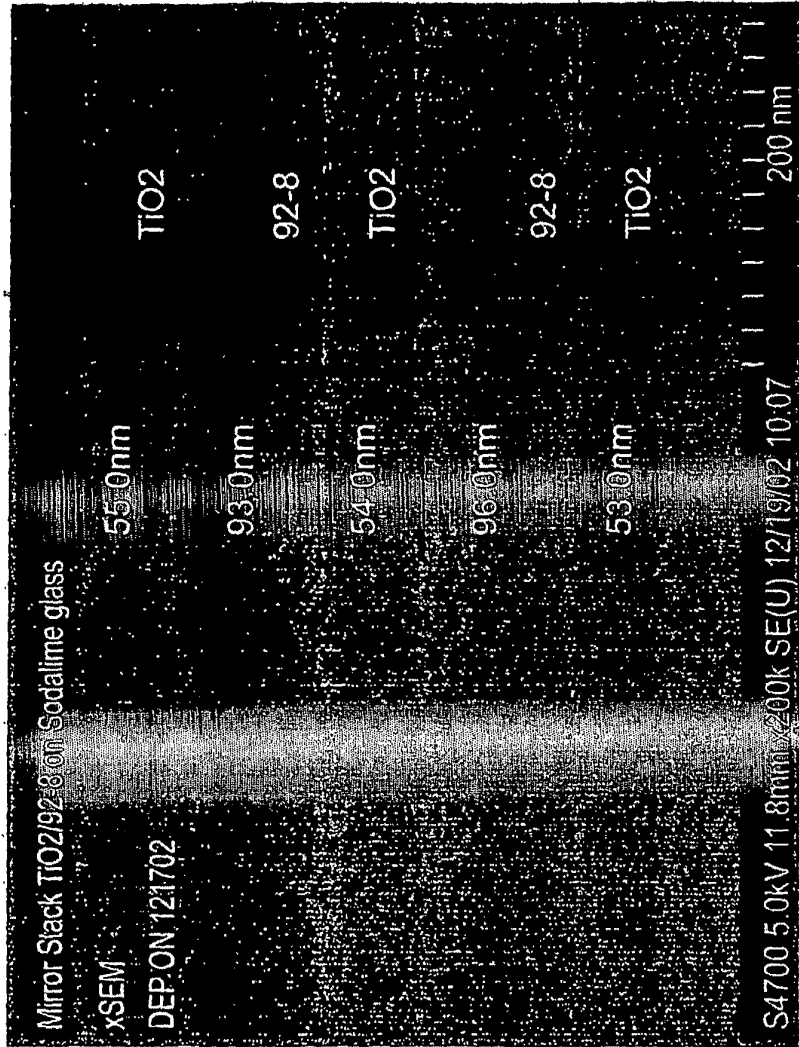


FIG. 10

SUBSTITUTE SHEET (RULE 26)



9/20

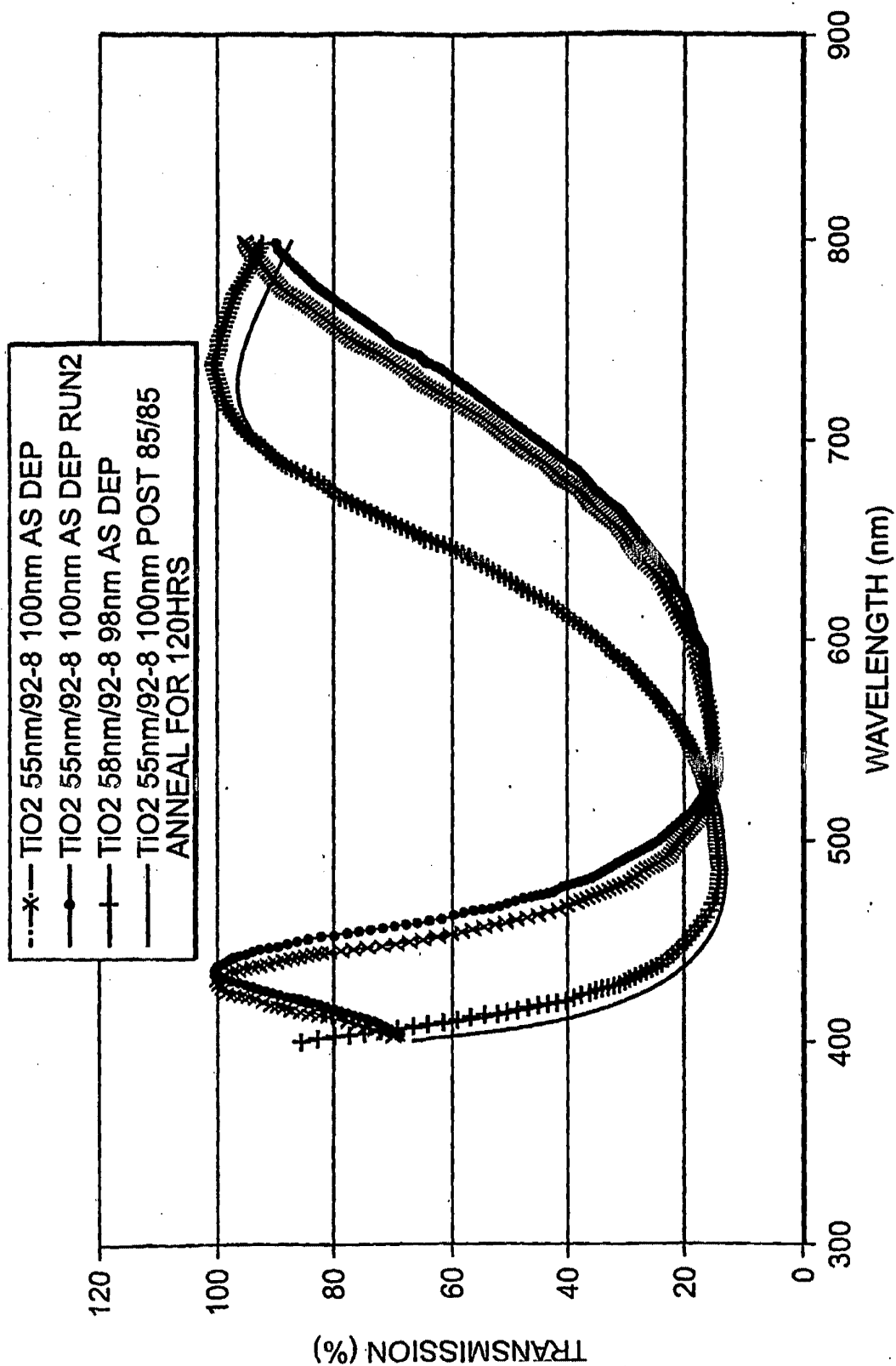
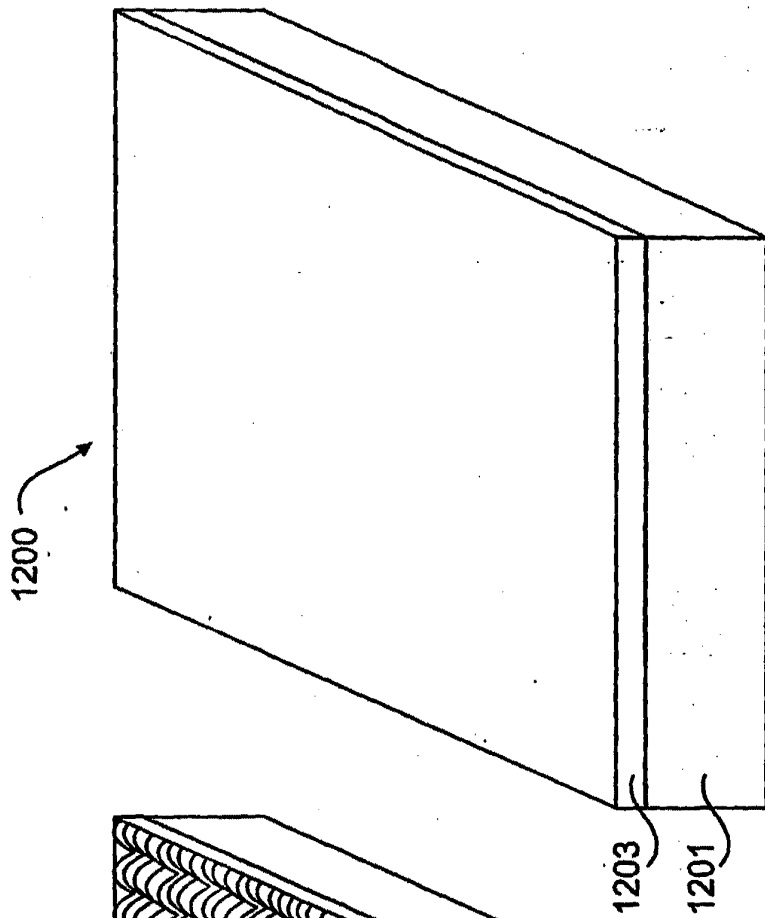
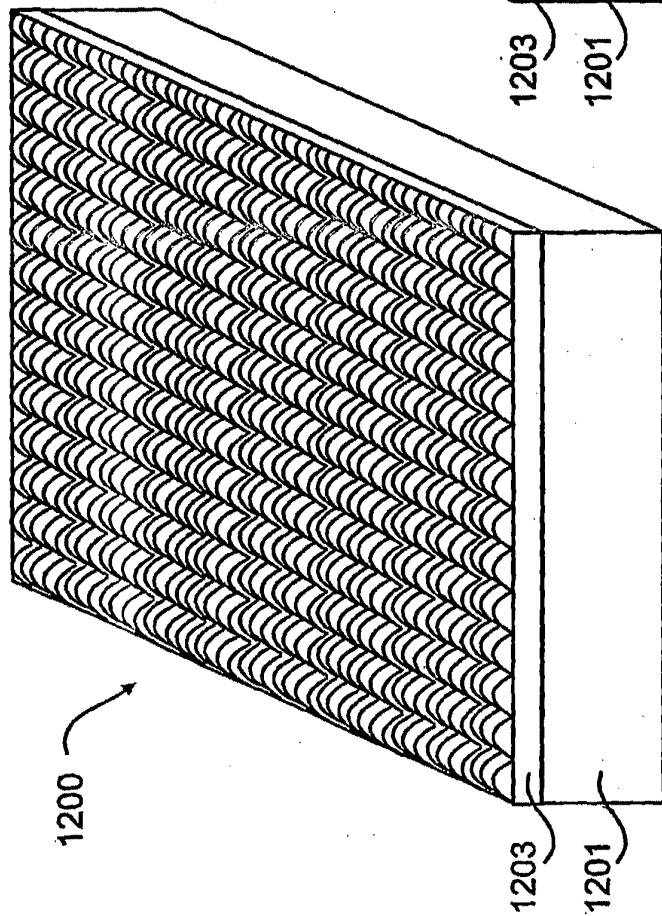


FIG. 11

SUBSTITUTE SHEET (RULE 26)



**FIG. 12A**



**FIG. 12B**

SUBSTITUTE SHEET (RULE 26)

11/20

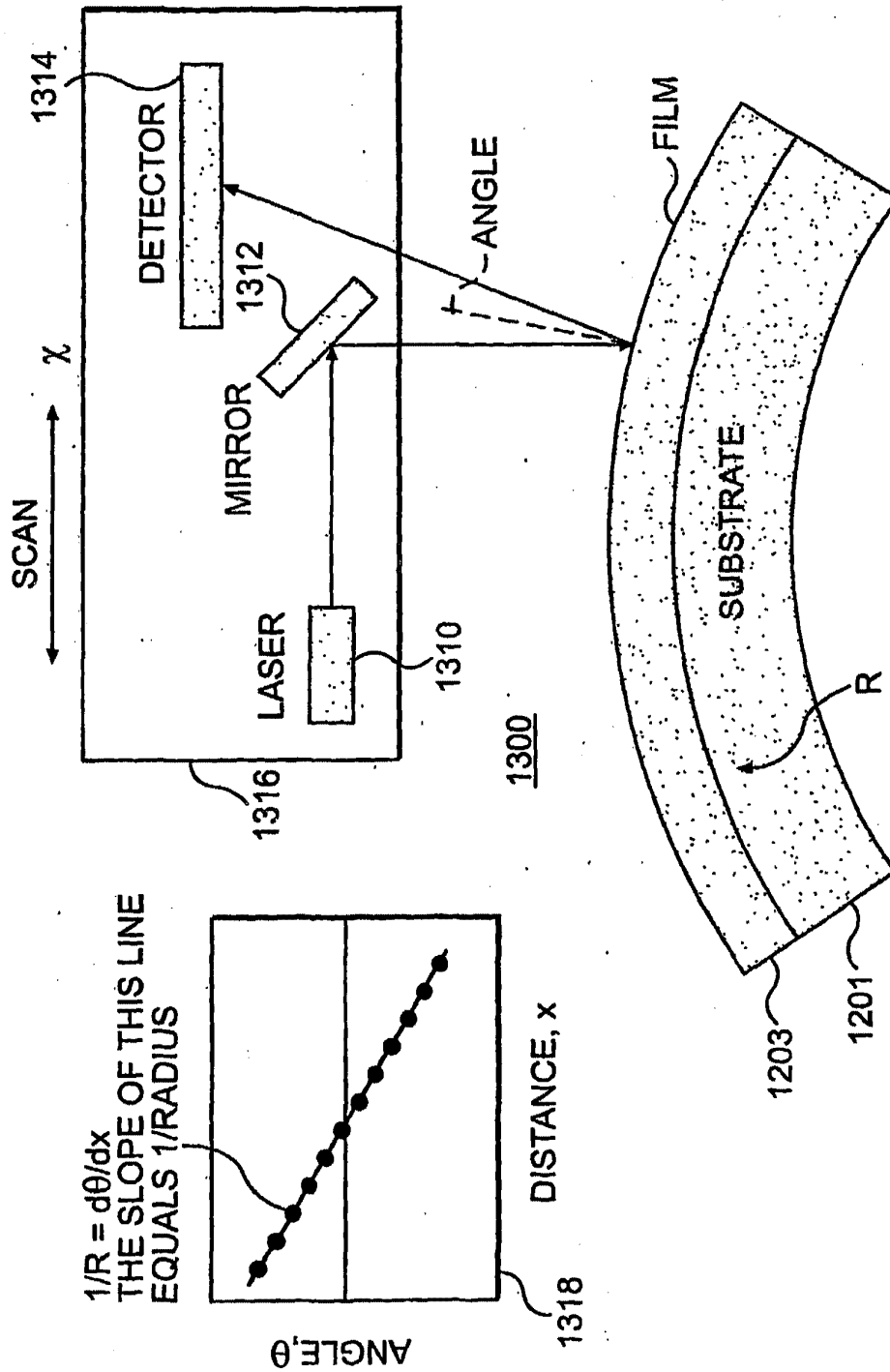
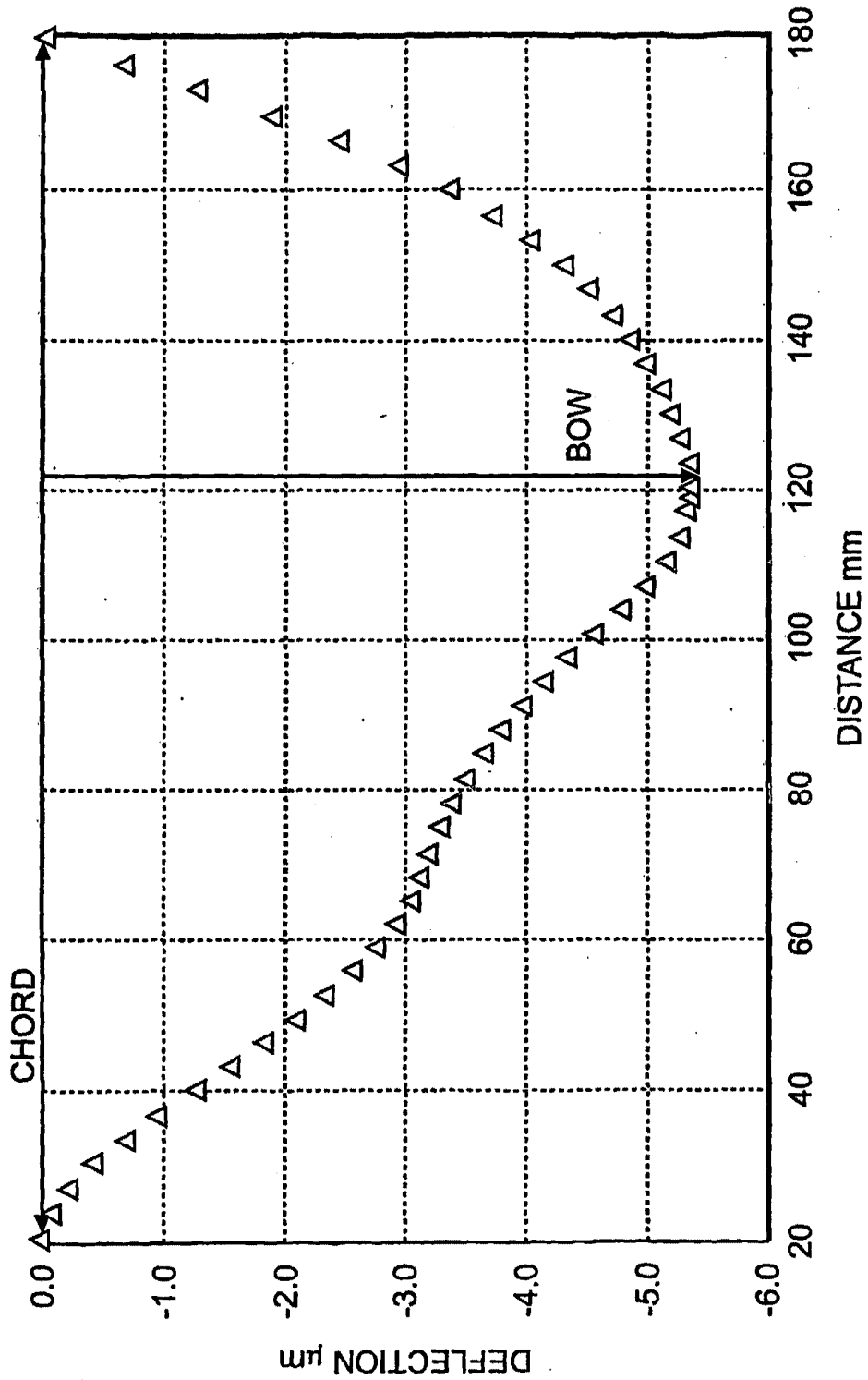


FIG. 13

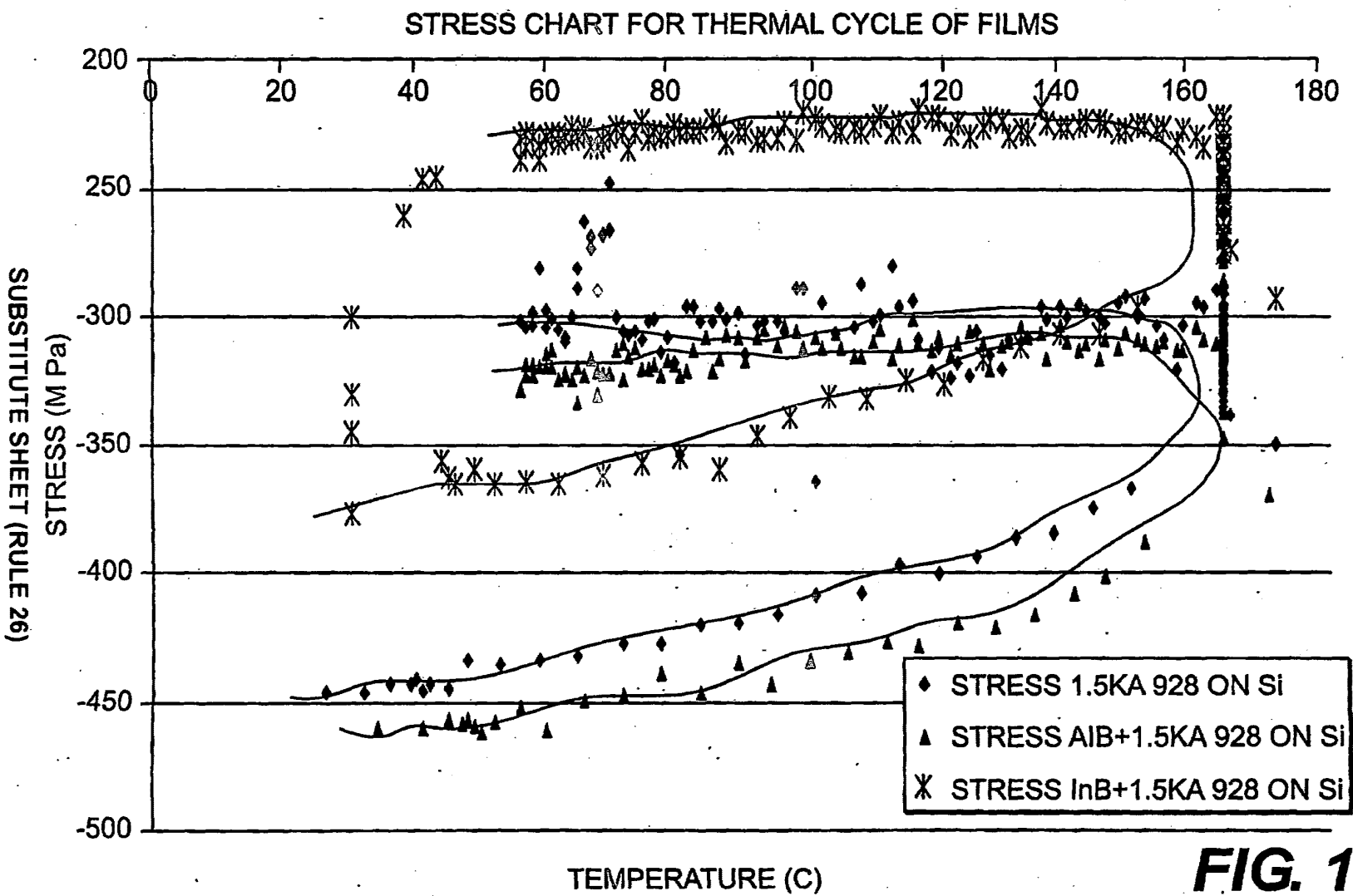
SUBSTITUTE SHEET (RULE 26)

12/20



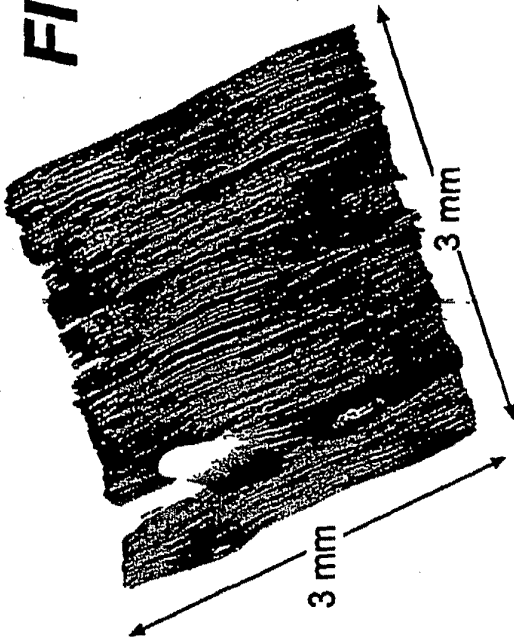
SUBSTITUTE SHEET (RULE 26)

FIG. 14

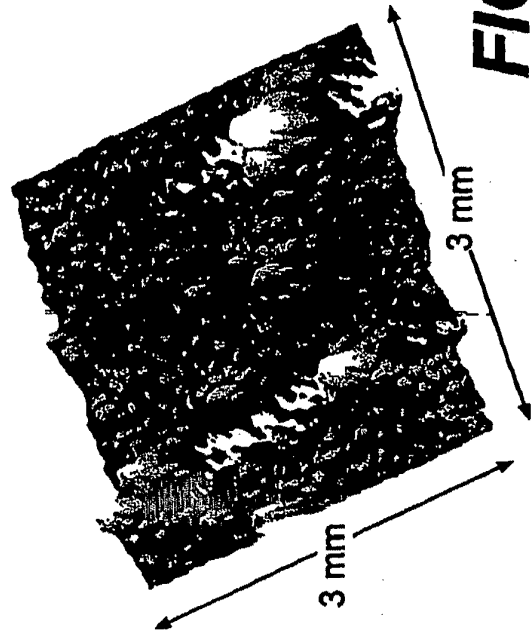


**FIG. 15**

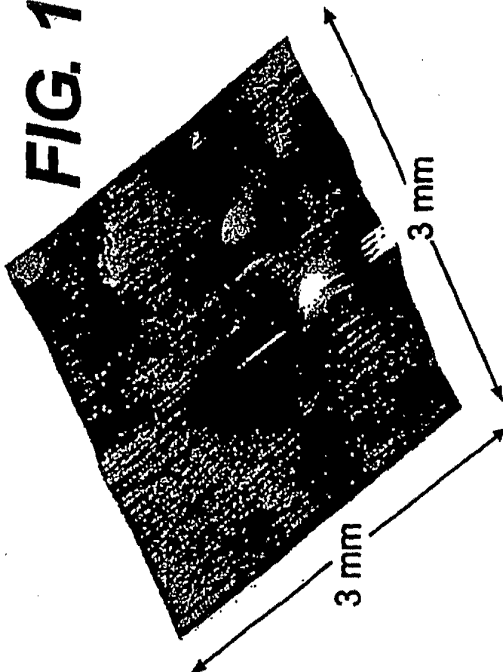
**FIG. 16B**



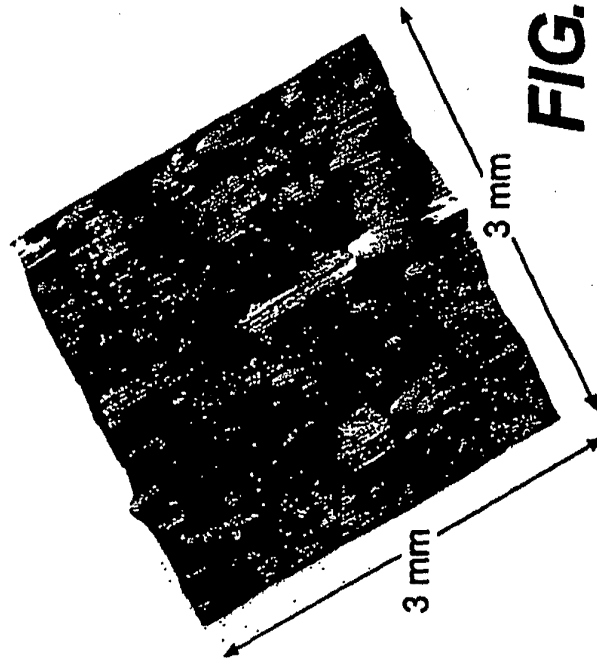
**FIG. 16D**



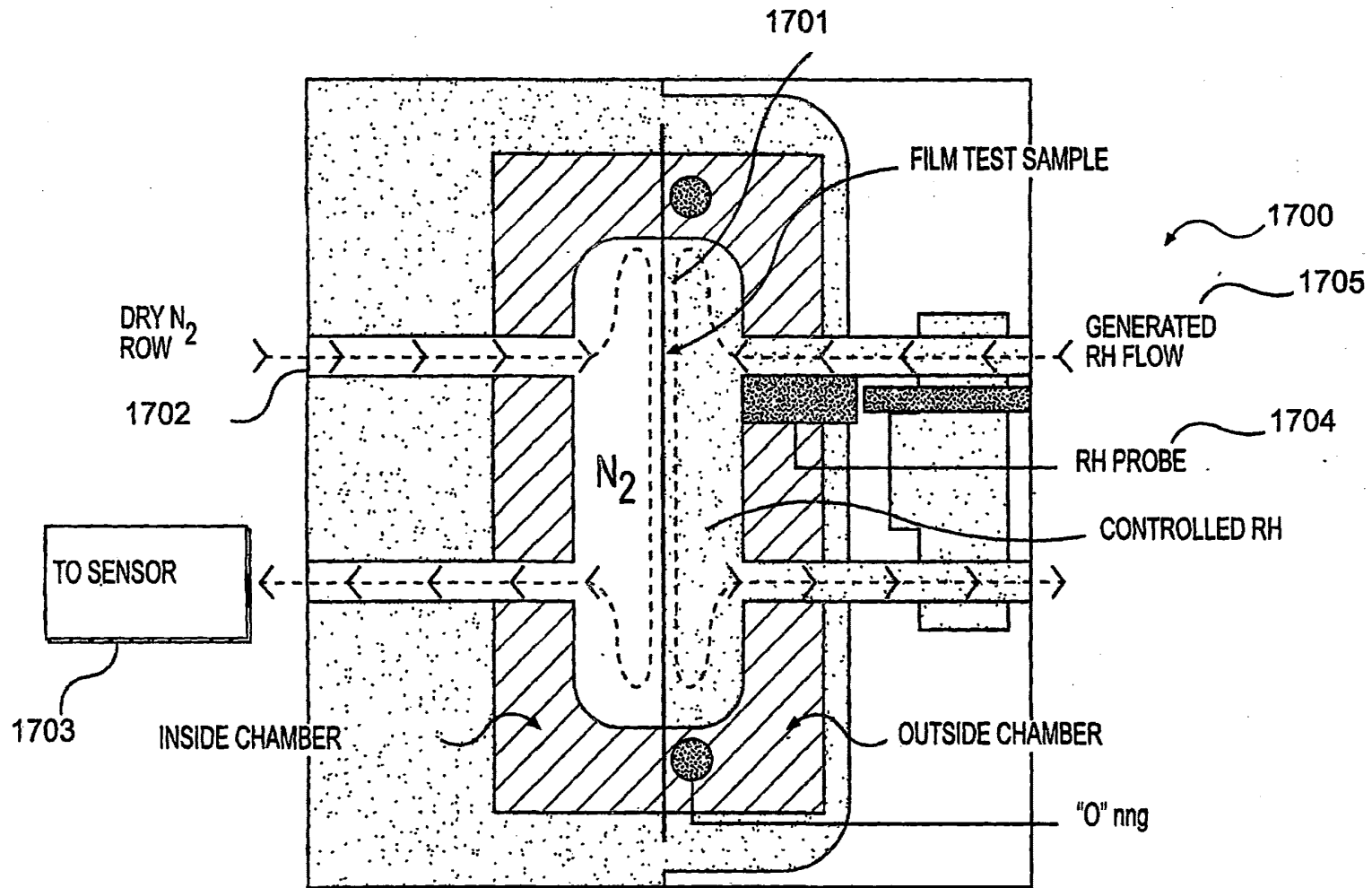
**FIG. 16A**



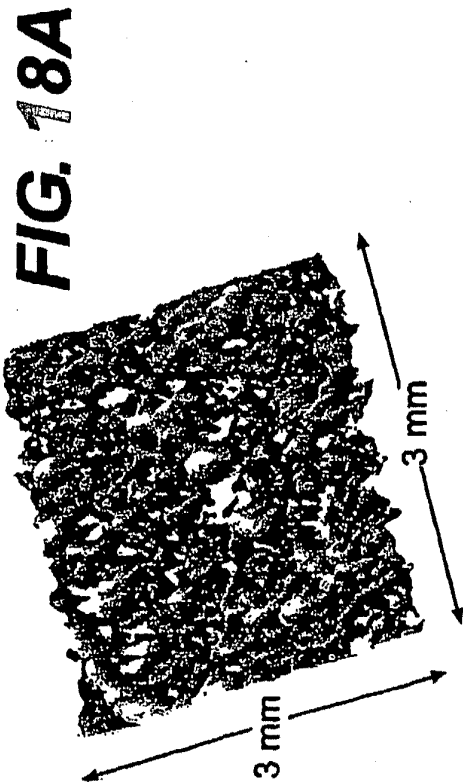
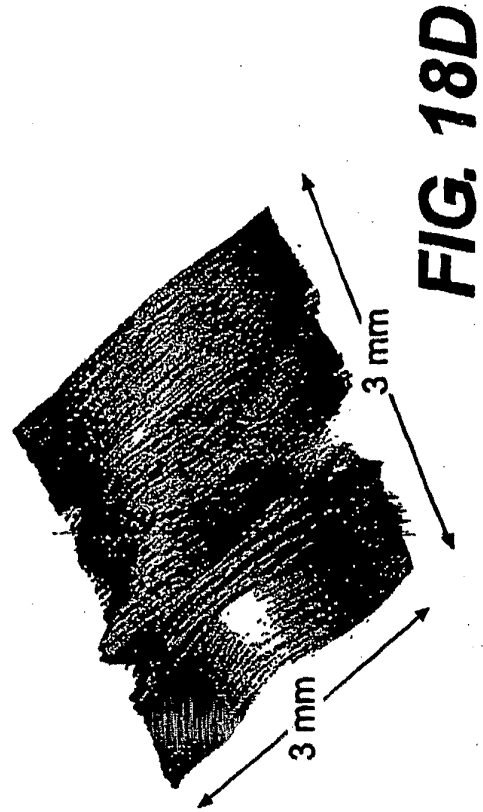
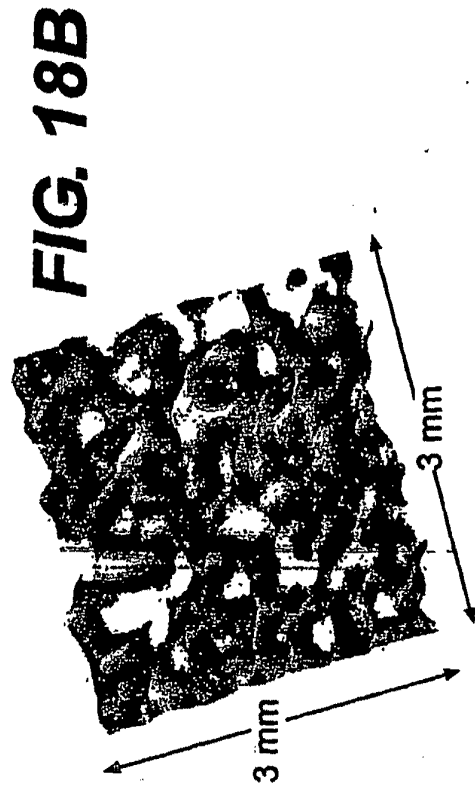
**FIG. 16C**



SUBSTITUTE SHEET (RULE 26)



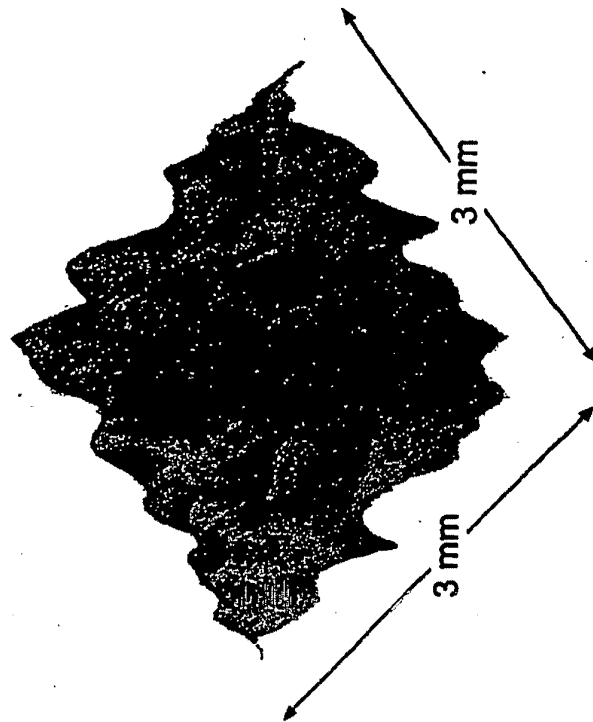
**FIG. 17**



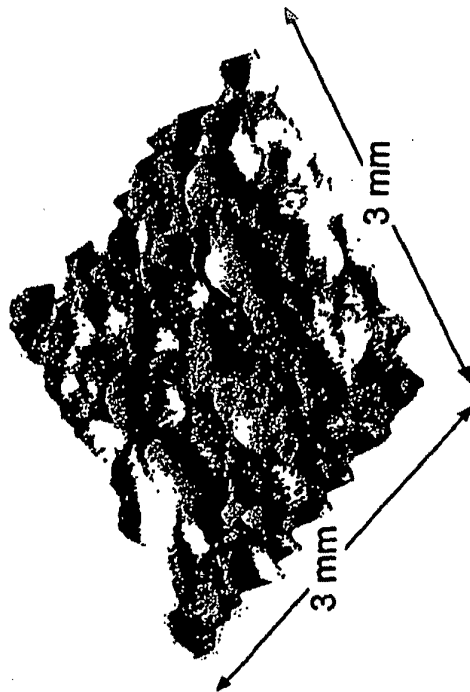
SUBSTITUTE SHEET (RULE 26)



17/20

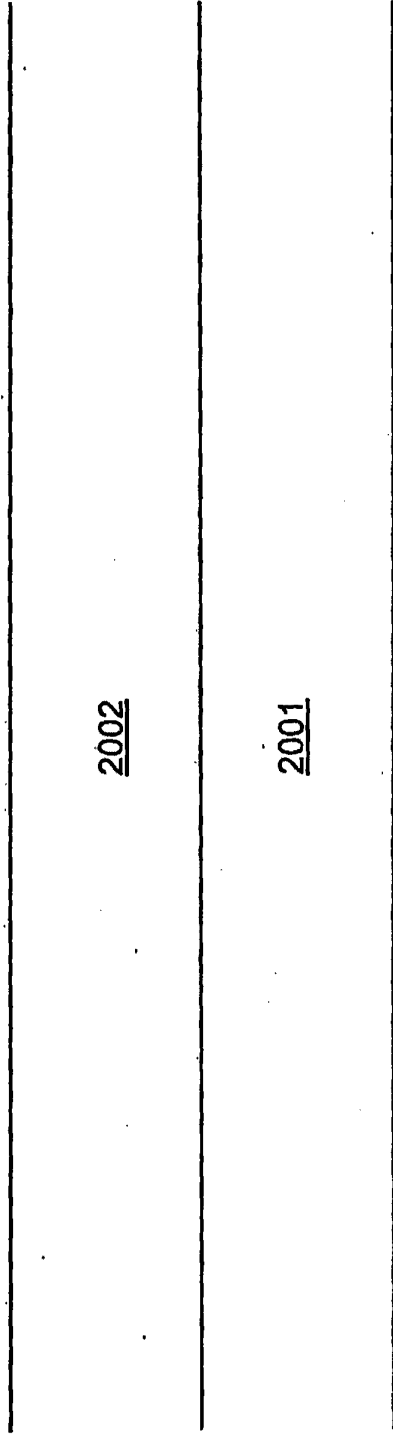


**FIG. 19B**



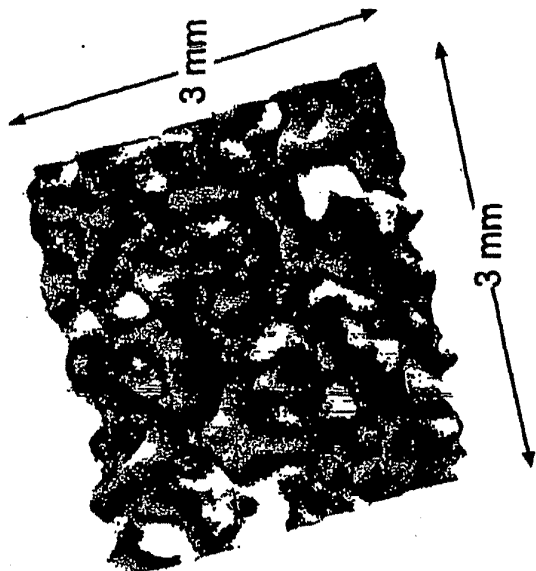
**FIG. 19A**

SUBSTITUTE SHEET (RULE 26)

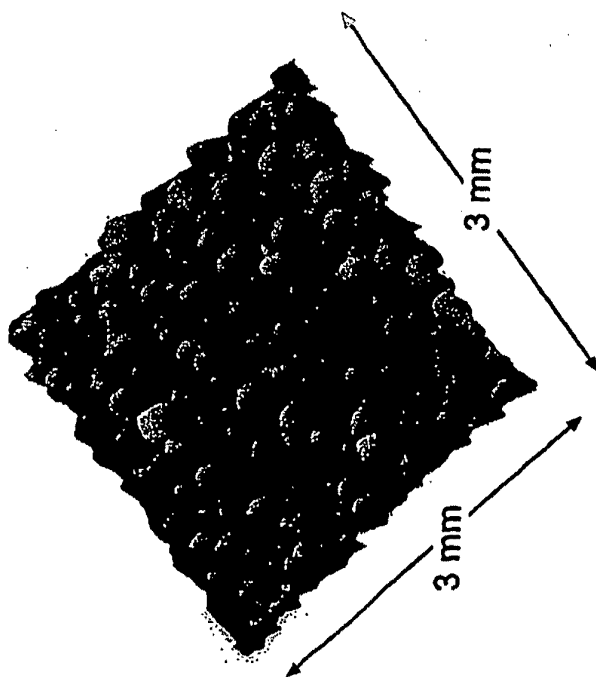


**FIG. 20**

SUBSTITUTE SHEET (RULE 26)



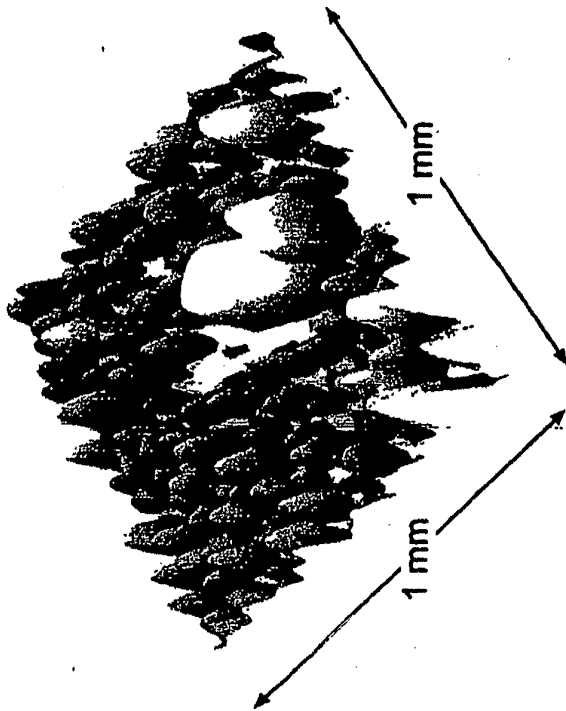
**FIG. 21B**



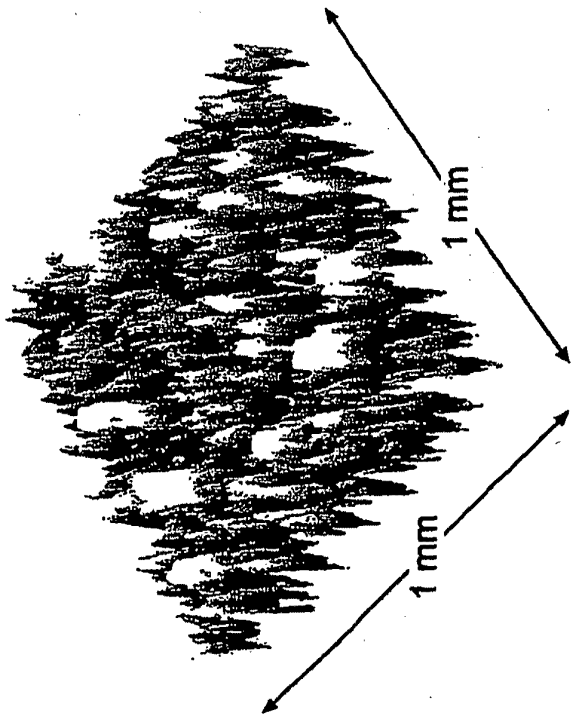
**FIG. 21A**

SUBSTITUTE SHEET (RULE 26)

20/20



**FIG. 22B**



**FIG. 22A**

SUBSTITUTE SHEET (RULE 26)

**This Page is Inserted by IFW Indexing and Scanning  
Operations and is not part of the Official Record**

**BEST AVAILABLE IMAGES**

Defective images within this document are accurate representations of the original documents submitted by the applicant.

Defects in the images include but are not limited to the items checked:

- BLACK BORDERS
- IMAGE CUT OFF AT TOP, BOTTOM OR SIDES
- FADED TEXT OR DRAWING
- BLURRED OR ILLEGIBLE TEXT OR DRAWING
- SKEWED/SLANTED IMAGES
- COLOR OR BLACK AND WHITE PHOTOGRAPHS
- GRAY SCALE DOCUMENTS
- LINES OR MARKS ON ORIGINAL DOCUMENT
- REFERENCE(S) OR EXHIBIT(S) SUBMITTED ARE POOR QUALITY
- OTHER: \_\_\_\_\_

**IMAGES ARE BEST AVAILABLE COPY.**

**As rescanning these documents will not correct the image problems checked, please do not report these problems to the IFW Image Problem Mailbox.**


**UNITED STATES PATENT AND TRADEMARK OFFICE**

UNITED STATES DEPARTMENT OF COMMERCE  
 United States Patent and Trademark Office  
 Address: COMMISSIONER FOR PATENTS  
 P.O. Box 1450  
 Alexandria, Virginia 22313-1450  
 www.uspto.gov

APPLICATION NUMBER	FILING OR 371 (c) DATE	FIRST NAMED APPLICANT	ATTY. DOCKET NO./TITLE
10/101,863	03/16/2002	Hongmei Zhang	M-12245 US

FINNEGAN, HENDERSON, FARABOW  
 GARRETT & DUNNER, L.L.P.  
 1300 I STREET N.W.  
 WASHINGTON, DC 20005-3315

**CONFIRMATION NO. 6938**

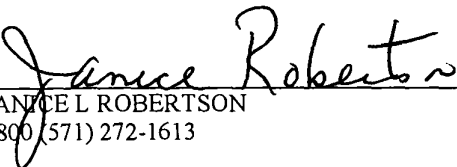

\*OC00000014956746\*

Date Mailed: 01/13/2005

**NOTICE OF ACCEPTANCE OF POWER OF ATTORNEY**

This is in response to the Power of Attorney filed 12/02/2003.

The Power of Attorney in this application is accepted. Correspondence in this application will be mailed to the above address as provided by 37 CFR 1.33.

  
 \_\_\_\_\_  
 JANICE L ROBERTSON  
 2800 (571) 272-1613

OFFICE COPY



UNITED STATES PATENT AND TRADEMARK OFFICE

UNITED STATES DEPARTMENT OF COMMERCE  
United States Patent and Trademark Office  
Address: COMMISSIONER FOR PATENTS  
P.O. Box 1450  
Alexandria, Virginia 22313-1450  
www.uspto.gov

APPLICATION NUMBER	FILING OR 371 (c) DATE	FIRST NAMED APPLICANT	ATTY. DOCKET NO./TITLE
10/101,863	03/16/2002	Hongmei Zhang	M-12245 US

CONFIRMATION NO. 6938

Skjerven Morrill Macpherson LLP  
Suite 700  
250 Metro Drive  
San Jose, CA 95110



\*OC000000014956630\*

Date Mailed: 01/13/2005

**NOTICE REGARDING CHANGE OF POWER OF ATTORNEY**

This is in response to the Power of Attorney filed 12/02/2003.

- The Power of Attorney to you in this application has been revoked by the assignee who has intervened as provided by 37 CFR 3.71. Future correspondence will be mailed to the new address of record(37 CFR 1.33).

\_\_\_\_\_  
JANICE L ROBERTSON  
2800 (571) 272-1613

OFFICE COPY



UNITED STATES PATENT AND TRADEMARK OFFICE

UNITED STATES DEPARTMENT OF COMMERCE  
United States Patent and Trademark Office  
Address: COMMISSIONER FOR PATENTS  
P.O. Box 1450  
Alexandria, Virginia 22313-1450  
www.uspto.gov

APPLICATION NO.	FILING DATE	FIRST NAMED INVENTOR	ATTORNEY DOCKET NO.	CONFIRMATION NO.
10/101,863	03/16/2002	Hongmei Zhang	M-12245 US	6938

7590 01/13/2005  
FINNEGAN, HENDERSON, FARABOW  
GARRETT & DUNNER, L.L.P.  
1300 I STREET N.W.  
WASHINGTON, DC 20005-3315

EXAMINER

ESTRADA, MICHELLE

ART UNIT PAPER NUMBER

2823

DATE MAILED: 01/13/2005

*Remail  
Case Address*

Please find below and/or attached an Office communication concerning this application or proceeding.



<b>Office Action Summary</b>	<b>Application No.</b> 10/101,863	<b>Applicant(s)</b> ZHANG ET AL.	
	<b>Examiner</b> Michelle Estrada	<b>Art Unit</b> 2823	<i>EW</i>

-- The MAILING DATE of this communication appears on the cover sheet with the correspondence address --

**Period for Reply**

A SHORTENED STATUTORY PERIOD FOR REPLY IS SET TO EXPIRE 3 MONTH(S) FROM THE MAILING DATE OF THIS COMMUNICATION.

- Extensions of time may be available under the provisions of 37 CFR 1.138(a). In no event, however, may a reply be timely filed after SIX (6) MONTHS from the mailing date of this communication.
- If the period for reply specified above is less than thirty (30) days, a reply within the statutory minimum of thirty (30) days will be considered timely.
- If NO period for reply is specified above, the maximum statutory period will apply and will expire SIX (6) MONTHS from the mailing date of this communication.
- Failure to reply within the set or extended period for reply will, by statute, cause the application to become ABANDONED (35 U.S.C. § 133). Any reply received by the Office later than three months after the mailing date of this communication, even if timely filed, may reduce any earned patent term adjustment. See 37 CFR 1.704(b).

**Status**

- 1)  Responsive to communication(s) filed on 23 July 2004.
- 2a)  This action is FINAL.                      2b)  This action is non-final.
- 3)  Since this application is in condition for allowance except for formal matters, prosecution as to the merits is closed in accordance with the practice under *Ex parte Quayle*, 1935 C.D. 11, 453 O.G. 213.

**Disposition of Claims**

- 4)  Claim(s) 1-14 and 20-24 is/are pending in the application.
  - 4a) Of the above claim(s) \_\_\_\_\_ is/are withdrawn from consideration.
- 5)  Claim(s) \_\_\_\_\_ is/are allowed.
- 6)  Claim(s) 1-13 and 20 is/are rejected.
- 7)  Claim(s) 7, 14 and 21-24 is/are objected to.
- 8)  Claim(s) \_\_\_\_\_ are subject to restriction and/or election requirement.

**Application Papers**

- 9)  The specification is objected to by the Examiner.
- 10)  The drawing(s) filed on \_\_\_\_\_ is/are: a)  accepted or b)  objected to by the Examiner.  
 Applicant may not request that any objection to the drawing(s) be held in abeyance. See 37 CFR 1.85(a).  
 Replacement drawing sheet(s) including the correction is required if the drawing(s) is objected to. See 37 CFR 1.121(d).
- 11)  The oath or declaration is objected to by the Examiner. Note the attached Office Action or form PTO-152.

**Priority under 35 U.S.C. § 119**

- 12)  Acknowledgment is made of a claim for foreign priority under 35 U.S.C. § 119(a)-(d) or (f).
    - a)  All    b)  Some \* c)  None of:
      - 1.  Certified copies of the priority documents have been received.
      - 2.  Certified copies of the priority documents have been received in Application No. \_\_\_\_\_.
      - 3.  Copies of the certified copies of the priority documents have been received in this National Stage application from the International Bureau (PCT Rule 17.2(a)).
- \* See the attached detailed Office action for a list of the certified copies not received.

**Attachment(s)**

- 1)  Notice of References Cited (PTO-892)
- 2)  Notice of Draftsperson's Patent Drawing Review (PTO-948)
- 3)  Information Disclosure Statement(s) (PTO-1449 or PTO/SB/08)  
 Paper No(s)/Mail Date 7/23/04, 9/2/04
- 4)  Interview Summary (PTO-413)  
 Paper No(s)/Mail Date. \_\_\_\_\_
- 5)  Notice of Informal Patent Application (PTO-152)
- 6)  Other: \_\_\_\_\_

**DETAILED ACTION**

***Claim Objections***

Claim 14 is objected to because of the following informalities: in line 2, it appears that "12" should be deleted. Appropriate correction is required.

***Claim Rejections - 35 USC § 103***

The following is a quotation of 35 U.S.C. 103(a) which forms the basis for all obviousness rejections set forth in this Office action:

(a) A patent may not be obtained though the invention is not identically disclosed or described as set forth in section 102 of this title, if the differences between the subject matter sought to be patented and the prior art are such that the subject matter as a whole would have been obvious at the time the invention was made to a person having ordinary skill in the art to which said subject matter pertains. Patentability shall not be negated by the manner in which the invention was made.

Claims 1-13 and 20 are rejected under 35 U.S.C. 103(a) as being unpatentable over the combination of Le et al. (2003/0077914) and Fukui et al. (5,755,938).

With respect to claim 1, Le et al. disclose providing pulsed DC power (22) to a target (14) (Page 4, Paragraph [0070]); providing bias power to a substrate (16) positioned opposite the target (Page 5, lines 13-14); providing process gas between the target and the substrate (Page 4, Paragraph [0067]).

With respect to claim 7, Le et al. disclose wherein the film is an upper cladding layer of a waveguide structure and the bias power is optimized to provide planarization Page 5, Paragraph [0075].

With respect to claim 8, Le et al. disclose wherein the process gas includes a mixture of oxygen and argon (Page 4, Paragraph [0067]).

With respect to claim 9, Le et al. disclose wherein the oxygen flow is adjusted to adjust the index of refraction of the film (Page 5, Paragraph [0076]).

With respect to claim 10, Le et al. disclose wherein the process gas further includes nitrogen (Page 5, Paragraph [0074]).

With respect to claim 11, Le et al. disclose wherein providing pulsed DC power to a target includes providing pulsed DC power to a target which has an area larger than that of the substrate (See fig. 3).

With respect to claim 12, Le et al. disclose further including uniformly sweeping the target with a magnetic field (Page 5, Paragraph [0073]).

With respect to claim 13, Le et al. disclose wherein uniformly sweeping the target with a magnetic field includes sweeping a magnet in one direction across the target where the magnet extends beyond the target in the opposite direction (Page 5, Paragraph [0073]).

With respect to claim 20, Le et al. disclose conditioning a target (Page 4, Paragraph [0070]); preparing the substrate (Page 3, Paragraph [0065]); adjusting the bias power to the substrate (Page 4, Paragraph [0041]); setting the process gas flow (Page 4, Paragraph [0067]); and applying pulsed DC power to the target to deposit the film (Page 4, Paragraph [0071]).

With respect to claims 2-4 and 6, One of ordinary skill in the art would have been led to the recited temperature, DC power, time pulse and bias power to routine experimentation to achieve a desire layer thickness, device dimension, device associated characteristics and device density on the finished wafer in view of the range

of values disclosed. Furthermore, Le et al. disclose that sets of process parameters depend on the specific process chamber (Page 6, Paragraph [0081]).

In addition, the selection of temperature, DC power, time pulse and bias power, is obvious because it is a matter of determining optimum process conditions by routine experimentation with a limited number of species of result effective variables. These claims are prima facie obvious without showing that the claimed ranges achieve unexpected results relative to the prior art range. In re Woodruff, 16 USPQ2d 1935, 1937 (Fed. Cir. 1990). See also In re Huang, 40 USPQ2d 1685, 1688 (Fed. Cir. 1996)(claimed ranges of a result effective variable, which do not overlap the prior art ranges, are unpatentable unless they produce a new and unexpected result which is different in kind and not merely in degree from the results of the prior art). See also In re Boesch, 205 USPQ 215 (CCPA) (discovery of optimum value of result effective variable in known process is ordinarily within skill or art) and In re Aller, 105 USPQ 233 (CCPA 1995) (selection of optimum ranges within prior art general conditions is obvious).

Note that the specification contains no disclosure of either the critical nature of the claimed temperature, DC power, time pulse and bias power or any unexpected results arising therefrom. Where patentability is said to be based upon particular chosen temperature, DC power, time pulse and bias power or upon another variable recited in a claim, the Applicant must show that the chosen temperature, DC power, time pulse and bias power are critical. In re Woodruff, 919 F.2d 1575, 1578, 16 USPQ2d 1934, 1936 (Fed. Cir. 1990).

Le et al. do not disclose providing a DC power through a filter.

With respect to claims 1 and 5, Fukui et al. disclose a sputtering process wherein the DC power supply (28) is connected through a band-pass filter.

It would have been within the scope of one of ordinary skill in the art to combine the teachings of Le et al. and Fukui et al. to enable the use of a DC power supply through a filter to be used in the process of Le et al. to adjust the impedance to have an infinite value so that no RF waves are superposed on a DC power from the DC power supply (Col. 6, lines 32-37).

#### ***Allowable Subject Matter***

Claims 7, 14 and 21-24 are objected to as being dependent upon a rejected base claim, but would be allowable if rewritten in independent form including all of the limitations of the base claim and any intervening claims.

#### ***Response to Arguments***

Applicant's arguments filed 7/23/04 have been fully considered but they are not persuasive. Applicant argues that Le et al. do not disclose a bias applied to the substrate. However, Applicant is directed to Page 5, lines 13-14, wherein Le et al. disclose applying a RF energy (bias) to the gas supplied to the substrate.

Applicant argues that Fukui does not teach a pulsed DC power supply. However, Fukui was not relied on upon for that purpose. Fukui teaches supplying power from a DC supply through a filter to the target. Fukui was relied on for the use of a filter to supply a power to the target.

In response to applicant's argument that the examiner's conclusion of obviousness is based upon improper hindsight reasoning, it must be recognized that any judgment on obviousness is in a sense necessarily a reconstruction based upon hindsight reasoning. But so long as it takes into account only knowledge which was within the level of ordinary skill at the time the claimed invention was made, and does not include knowledge gleaned only from the applicant's disclosure, such a reconstruction is proper. See *In re McLaughlin*, 443 F.2d 1392, 170 USPQ 209 (CCPA 1971).

Applicant argues that utilizing a filter provided for a DC power supply is not obvious and may not be necessary in the system taught by Le because of the lack of a bias. However, Le discloses applying a bias to energize the gas being applied to the substrate, as explained above. Therefore, a filter may be used to provide the pulsed DC power through the filter since a bias is being applied.

Applicant argues that there is no suggestion in Fukui that a pulsed DC power supply can be substituted for the RF power supply coupled to the target, nor would one skilled in the art be inclined to replace that RF power supply with a pulsed DC power supply. However, the Examiner is not substituting the pulsed DC power supply for the

RF power supply coupled to the target. The rejection is based on utilizing the filter of Fukui to be used in the pulsed DC power supply of Le.

**THIS ACTION IS MADE FINAL.** Applicant is reminded of the extension of time policy as set forth in 37 CFR 1.136(a).

A shortened statutory period for reply to this final action is set to expire **THREE MONTHS** from the mailing date of this action. In the event a first reply is filed within **TWO MONTHS** of the mailing date of this final action and the advisory action is not mailed until after the end of the **THREE-MONTH** shortened statutory period, then the shortened statutory period will expire on the date the advisory action is mailed, and any extension fee pursuant to 37 CFR 1.136(a) will be calculated from the mailing date of the advisory action. In no event, however, will the statutory period for reply expire later than **SIX MONTHS** from the mailing date of this final action.


Any inquiry concerning this communication or earlier communications from the examiner should be directed to Michelle Estrada whose telephone number is 571-272-1858. The examiner can normally be reached on Monday through Friday.


If attempts to reach the examiner by telephone are unsuccessful, the examiner's supervisor, Olik Chaudhuri can be reached on 571-272-1855. The fax phone numbers for the organization where this application or proceeding is assigned are 703-308-7722 for regular communications and 703-308-7724 for After Final communications.

Application/Control Number: 10/101,863  
Art Unit: 2823

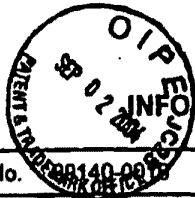
Page 8

Any inquiry of a general nature or relating to the status of this application or proceeding should be directed to the receptionist whose telephone number is 571-272-2800.

  
MEstrada  
October 4, 2004

  
Oik Chaudhuri  
Supervisory Patent Examiner  
Technology Center 2800





OMB No. 0651-0011

INFORMATION DISCLOSURE CITATION

Atty. Docket No. 09140-00	Appln. No. 10/101,853
Applicant ZHANG et al.	
Filing Date March 16, 2002	Group: 2823

U.S. PATENT DOCUMENTS						
Examiner Initial*	Document Number	Issue Date	Name	Class	Sub Class	Filing Date if Appropriate
<i>ME</i>	3,616,403	Oct. 26, 1971	Collins et al.	204	192	
<i>ME</i>	3,850,604	Nov. 26, 1974	Klein	65	32	
<i>ME</i>	4,111,523	Sep. 5, 1978	Kaminow et al.	350	96.14	
<i>ME</i>	4,819,680	Oct. 28, 1986	Nourshargh et al.	65	3.12	
<i>ME</i>	5,196,041	Mar. 23, 1993	Tumminelli et al.	65	30.1	
<i>ME</i>	5,287,427	Feb. 15, 1994	Atkins et al.	385	124	
<i>ME</i>	6,511,615 B1	Jan. 28, 2003	Dawes et al.	264	1.21	
<i>ME</i>	6,563,998 B1	May 13, 2003	Farah et al.	385	131	
<i>ME</i>	6,805,228 B1	Aug. 12, 2003	Kawaguchi et al.	216	24	
<i>ME</i>	6,615,614 B1	Sep. 9, 2003	Makikawa et al.	65	386	

FOREIGN PATENT DOCUMENTS						
Document Number	Publication Date	Country	Class	Sub Class	Translation Yes or No	

OTHER DOCUMENTS (Including Author, Title, Date, Pertinent Pages, Etc.)	

Examiner <i>Michelle Cotiada</i>	Date Considered <i>9/28/04</i>
*Examiner: Initial if reference considered, whether or not citation is in conformance with MPEP 609; draw line through citation if not in conformance and not considered. Include copy of this form with next communication to applicant.	
Form PTO 1449	Patent and Trademark Office - U.S. Department of Commerce



OMB No. 0651-0011

INFORMATION DISCLOSURE CITATION

Atty. Docket No.	09140-0016	Appln. No.	10/101,863
Applicant	ZHANG et al.		
Filing Date	March 16, 2002	Group:	2823

U.S. PATENT DOCUMENTS						
Examiner Initial*	Document Number	Issue Date	Name	Class	Sub Class	Filing Date, If Appropriate
<i>ME</i>	2002/0106297		Ueno et al.	419	12	Aug. 08, 2002
<i>ME</i>	2003/0019326		Han et al.	45	245	Jan. 30, 2003
<i>ME</i>	2003/0063883		Demaray et al.	385	129	Apr. 3, 2003
<i>ME</i>	2003/0175142		Milonopoulou et al.	419	49	Sep. 18, 2003
<i>ME</i>	4,437,966	Mar. 7, 1961	Hope et al	204	298	
<i>ME</i>	4,915,810	Apr. 10, 1990	Kestigian et al.	204	298.04	
<i>ME</i>	4,978,437	Dec. 18, 1990	Wirz	204	192.	
<i>ME</i>	5,174,876	Dec. 29, 1992	Buchal et al.	427	526	
<i>ME</i>	5,200,029	Apr. 6, 1993	Bruce et al.	156	657	
<i>ME</i>	5,206,925	Apr. 27, 1993	Nakazawa et al.	385	142	
<i>ME</i>	5,225,288	Jul. 6, 1993	Beeson et al.	428	475.5	
<i>ME</i>	5,237,439	Aug. 17, 1993	Misono et al.	359	74	
<i>ME</i>	5,252,194	Oct. 12, 1993	Demaray et al.	204	298	
<i>ME</i>	5,303,319	Apr. 12, 1994	Ford et al.	385	131	
<i>ME</i>	5,381,262	Jan. 10, 1995	Arima et al.	359	341	
<i>ME</i>	5,427,669	Jun. 27, 1995	Drummond	204	298.2	
<i>ME</i>	5,475,528	Dec. 12, 1995	LaBorde	359	341	
<i>ME</i>	5,483,613	Jan. 9, 1996	Bruce et al.	385	129	
<i>ME</i>	5,555,127	Sep. 10, 1996	Abdelkader et al.	359	341	
<i>ME</i>	5,565,071	Oct. 15, 1996	Demaray et al.	204	192	
<i>ME</i>	5,603,816	Feb. 18, 1997	Demaray et al.	204	298	

Examiner <i>Michelle Estrade</i>	Date Considered <i>9/28/04</i>
----------------------------------	--------------------------------

\*Examiner: Initial if reference considered, whether or not citation is in conformance with MPEP 609; draw line through citation if not in conformance and not considered. Include copy of this form with next communication to applicant.



OMB No. 0651-0011

**INFORMATION DISCLOSURE CITATION**

Applicant	ZHANG et al.	Appln. No.	10/101,863
Filing Date	March 16, 2002	Group:	2823

U.S. PATENT DOCUMENTS						
Examiner Initial*	Document Number	Issue Date	Name	Class	Sub Class	Filing Date If Appropriate
<i>AK</i>	5,613,995	Mar. 25, 1997	Bhandarkar et al.	65	384	
<i>AK</i>	5,654,054	Aug. 5, 1997	Tropsha et al.	428	36.6	
<i>AK</i>	5,693,956	Dec. 2, 1997	Shi et al.	257	40	
<i>AK</i>	5,718,813	Feb. 17, 1998	Drummond	204	192.2	
<i>AK</i>	5,719,976	Feb. 17, 1998	Henry et al.	385	50	
<i>AK</i>	5,792,550	Aug. 11, 1998	Phillips et al.	428	336	
<i>AK</i>	5,841,931	Nov. 24, 1998	Foresi et al.	385	131	
<i>AK</i>	5,847,865	Dec. 8, 1998	Gopinath et al.	359	343	
<i>AK</i>	5,855,744	Jan. 5, 1999	Halsey et al.	204	192	
<i>AK</i>	5,948,215	Sep. 7, 1999	Lantsman	204	192.12	
<i>AK</i>	5,961,682	Oct. 5, 1999	Lee et al.	65	384	
<i>AK</i>	5,977,582	Nov. 2, 1999	Fleming et al.	257	310	
<i>AK</i>	6,001,224	Dec. 14, 1999	Drummond	204	192.12	
<i>AK</i>	6,024,844	Feb. 15, 2000	Drummond et al.	204	192.12	
<i>AK</i>	6,051,114	Apr. 18, 2000	Yao et al.	204	192.3	
<i>AK</i>	6,093,944	Jul. 25, 2000	VanDover	257	310	
<i>AK</i>	6,162,709	Dec. 19, 2000	Raux et al.	438	513	
<i>AK</i>	6,176,986	Jan. 23, 2001	Watanabe et al.	204	298.13	
<i>AK</i>	6,248,291	Jun. 19, 2001	Nakagama et al.	419	46	
<i>AK</i>	6,280,585 B1	Aug. 28, 2001	Obinata et al.	204	298.19	
<i>AK</i>	6,287,986	Sep. 11, 2001	Mihara	438	763	

Examiner <i>Michelle Cotradu</i>	Date Considered <i>9/28/04</i>
*Examiner: Initial if reference considered, whether or not citation is in conformance with MPEP 609; draw line through citation if not in conformance and not considered. Include copy of this form with next communication to applicant.	
Form PTO 1449	Patent and Trademark Office - U.S. Department of Commerce



OMB No. 0651-0011

**INFORMATION DISCLOSURE CITATION**

Applicant	ZHANG et al.	Appn. No.	10/101,863
Filing Date	March 18, 2002	Group:	2823

U.S. PATENT DOCUMENTS						
Examiner Initial*	Document Number	Issue Date	Name	Class	Sub Class	Filing Date If Appropriate
<i>[Signature]</i>	6,290,822	Sep. 18, 2001	Fleming et al.	204	192.22	
<i>[Signature]</i>	6,344,419	Feb. 5, 2002	Forster et al.	438	758	
<i>[Signature]</i>	6,350,353	Feb. 28, 2002	Gopalraja et al.	204	192.3	
<i>[Signature]</i>	6,358,810	Mar. 19, 2002	Dornfest et al.	438	396	
<i>[Signature]</i>	6,409,965	Jun. 25, 2002	Nagate et al.	419	26	
<i>[Signature]</i>	6,413,382	Jul. 2, 2002	Wang et al.	204	192.12	
<i>[Signature]</i>	6,537,428	Mar. 25, 2003	Xiong et al.	204	192.13	
<i>[Signature]</i>	6,602,338	Aug. 5, 2003	Chen et al.	252	301.4	

FOREIGN PATENT DOCUMENTS						
	Document Number	Publication Date	Country	Class	Sub Class	Translation Yes or No
<i>[Signature]</i>	EP 0 820 088	01/21/98	Europe	H 01 J	37/34	
<i>[Signature]</i>	EP 0 867 985 A1	09/01/98	Europe	H 01 S	3/06	
<i>[Signature]</i>	JP 6-010127	01/18/94	Japan	C 23 C	14/35	Abstract
<i>[Signature]</i>	JP 6-100333	12/04/94	Japan	C 03 C	21/00	Abstract
<i>[Signature]</i>	WO 00/22742	04/01/00	PCT	H 04 B		
<i>[Signature]</i>	WO 00/36865	06/22/00	PCT	H 01 L	51/20	
<i>[Signature]</i>	WO 02/12932	02/14/02	PCT	H 01 S	3/16	
<i>[Signature]</i>	WO 96/23085	08/01/96	PCT	C 23 C	14/34	
<i>[Signature]</i>	WO 97/35044	09/25/97	PCT	C 23 C	14/40	

Examiner	<i>Michelle Estrada</i>	Date Considered	<i>9/28/04</i>
*Examiner:	Initial if reference considered, whether or not citation is in conformance with MPEP 609; draw line through citation if not in conformance and not considered. Include copy of this form with next communication to applicant.		
Form PTO 1449	Patent and Trademark Office - U.S. Department of Commerce		



OMB No. 0651-0011

**INFORMATION DISCLOSURE CITATION**

Applicant	ZHANG et al.	Appn. No.	10/101,863
Filing Date	March 16, 2002	Group:	2823

OTHER DOCUMENTS (Including Author, Title, Date, Pertinent Pages, Etc.)	
<i>me</i>	BARBIER, Denis, "Performances and potential applications of erbium doped planar waveguide amplifiers and lasers," <i>GeoO</i> , pp. 58-63.
<i>me</i>	BELKIND et al., "Using pulsed direct current power for reactive sputtering of Al <sub>2</sub> O <sub>3</sub> ," <i>J. Vac. Sci. Technol. A</i> 17(4), pp. 1934-40 (Jul. 1999).
<i>me</i>	BYER et al., "Nonlinear Optics and Solid-state Lasers," <i>IEEE Journal on Selected Topics in Quantum Electronics</i> , Vol. 6, No. 6, pp. 921-929 (Nov. 2000).
<i>me</i>	FUJII et al., "1.54 μm photoluminescence of Er <sup>3+</sup> doped into SiO <sub>2</sub> films containing Si nanocrystals: Evidence for energy transfer from Si nanocrystals for Er <sup>3+</sup> ," <i>Appl. Phys. Lett.</i> , 71 (9), pp. 1198-1200 (September, 1997).
<i>me</i>	KELLY et al., "Reactive pulsed magnetron sputtering process for alumina films," <i>J. Vac. Sci. Technol. A</i> 18(6), pp. 2890-96 (Nov. 2000).
<i>me</i>	KELLY et al., "Control of the structure and properties of aluminum oxide coatings deposited by pulsed magnetron sputtering," <i>J. Vac. Sci. Technol. A</i> 17(3), pp. 945-953 (May 1999).
<i>me</i>	PAN et al., "Planar Er <sup>3+</sup> -doped aluminosilicate waveguide amplifier with more than 10 dB gain across C-band," <i>Optical Society of America</i> , 3 pages (2000).
<i>me</i>	ROBERTS et al., "The Photoluminescence of Erbium-doped Silicon Monoxide," <i>Department of Electronics and Computer Science</i> , 7 pages (June 1996).
<i>me</i>	SCHILLER et al. "PVD Coating of Plastic Webs and Sheets with High Rates on Large Areas," <i>European Materials Research Society 1999 Spring Meeting, Strasbourg, France (June 1-4, 1999)</i> .
<i>me</i>	SHAW et al. "Use of Vapor Deposited Acrylate Coatings to Improve the Barrier Properties of Metallized Film," <i>Society of Vacuum Coaters 505/856-7168, 37th Annual Technical Conference Proceedings</i> , pp. 240-244 (1994).
<i>me</i>	SHIN et al. "Dielectric and Electrical Properties of Sputter Grown (Ba,Sr)TiO <sub>3</sub> Thin Films," <i>J. Appl. Phys.</i> , Vol. 86, No. 1, pp. 506-513, (July 1, 1999).
<i>me</i>	SHMULOVICH et al., "Recent progress in Erbium-doped waveguide amplifiers," <i>Bell Laboratories</i> , 3 pages (1999).
<i>me</i>	TING et al., "Study of planarized sputter-deposited SiO <sub>2</sub> ," <i>J. Vac. Sci. Technol.</i> , 15(3) pp. 1105-1112 (May/Jun. 1978).

Examiner	<i>Michelle Strada</i>	Date Considered	<i>9/28/04</i>
*Examiner:	Initial if reference considered, whether or not citation is in conformance with MPEP 609; draw line through citation if not in conformance and not considered. Include copy of this form with next communication to applicant.		
Form PTO 1449	Patent and Trademark Office - U.S. Department of Commerce		



IFW



UNITED STATES PATENT AND TRADEMARK OFFICE

UNITED STATES DEPARTMENT OF COMMERCE  
United States Patent and Trademark Office  
Address: COMMISSIONER FOR PATENTS  
P.O. Box 1450  
Alexandria, Virginia 22313-1450  
www.uspto.gov

APPLICATION NUMBER	FILING OR 371 (c) DATE	FIRST NAMED APPLICANT	ATTY. DOCKET NO./TITLE
10/101,863	03/16/2002	Hongmei Zhang	M-12245 US

CONFIRMATION NO. 6938

Skjerven Morrill Macpherson LLP  
Suite 700  
250 Metro Drive  
San Jose, CA 95110

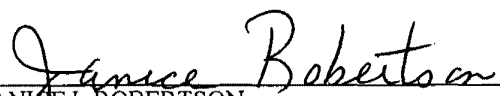


Date Mailed: 01/13/2005

NOTICE REGARDING CHANGE OF POWER OF ATTORNEY

This is in response to the Power of Attorney filed 12/02/2003.

- The Power of Attorney to you in this application has been revoked by the assignee who has intervened as provided by 37 CFR 3.71. Future correspondence will be mailed to the new address of record(37 CFR 1.33).

  
 \_\_\_\_\_  
 JANICE L ROBERTSON  
 2800 (571) 272-1613

FORMER ATTORNEY/AGENT COPY

RECEIVED  
MAR 17 2005  
OIP/E/JCWS



UNITED STATES PATENT AND TRADEMARK OFFICE

UNITED STATES DEPARTMENT OF COMMERCE  
United States Patent and Trademark Office  
Address: COMMISSIONER FOR PATENTS  
P.O. Box 1450  
Alexandria, Virginia 22313-1450  
www.uspto.gov

APPLICATION NUMBER	PATENT NUMBER	GROUP ART UNIT	FILE WRAPPER LOCATION
10/101,863		2823	06B0

## Correspondence Address / Fee Address Change

The following fields have been set to Customer Number 22852 on 04/08/2005

- Correspondence Address

**The address of record for Customer Number 22852 is:**

FINNEGAN, HENDERSON, FARABOW, GARRETT & DUNNER  
LLP  
901 NEW YORK AVENUE, NW  
WASHINGTON, DC 20001-4413



Page 1 of 1  
2823 IFW  
IFW



UNITED STATES PATENT AND TRADEMARK OFFICE

UNITED STATES DEPARTMENT OF COMMERCE  
United States Patent and Trademark Office  
Address: COMMISSIONER FOR PATENTS  
P.O. Box 3450  
Alexandria, Virginia 22313-1450  
www.uspto.gov

APPLICATION NUMBER	FILING OR 371 (c) DATE	FIRST NAMED APPLICANT	ATTY. DOCKET NO./TITLE
10/101,863	03/16/2002	Hongmei Zhang	M-12245 US

CONFIRMATION NO. 6938

Skjerven Morrill Macpherson LLP  
Suite 700  
250 Metro Drive  
San Jose, CA 95110



Date Mailed: 01/13/2005

NOTICE REGARDING CHANGE OF POWER OF ATTORNEY

This is in response to the Power of Attorney filed 12/02/2003.

- The Power of Attorney to you in this application has been revoked by the assignee who has intervened as provided by 37 CFR 3.71. Future correspondence will be mailed to the new address of record(37 CFR 1.33).

*Janice Robertson*  
\_\_\_\_\_  
JANICE L ROBERTSON  
2800 (371) 272-1613

FORMER ATTORNEY/AGENT COPY

RECEIVED  
MAR 17 2005  
OIPF/JCWS

RECEIVED  
APR 18 2005  
OIPF/JCWS

Best Available Copy

Organization \_\_\_\_\_ Bldg./Room \_\_\_\_\_

UNITED STATES PATENT AND TRADEMARK OFFICE

P.O. Box 1450

Alexandria, VA. 22313-1450

If Undeliverable Return In Ten Days

Official Business

Penalty For Private Use, \$300

**RECEIVED** AN EQUAL OPPORTUNITY EMPLOYER  
APR 08 2005  
USPTO MAIL CENTER FORWARDING ORDER  
EXPIRED

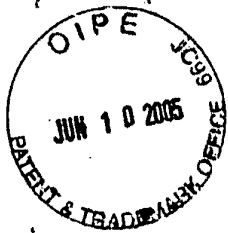


UNITED STATES POSTAGE U.S. OFFICIAL MAIL  
PENALTY FOR PRIVATE USE \$300  
02 1A \$ 00.37<sup>0</sup>  
0004204055 MAR 23 2005  
MAILED FROM ZIP CODE 22314

95110+1363 04

22313/1450





6-13-05

2823\$  
ATC

PATENT  
Customer No. 22,852  
Attorney Docket No. 9140.0016-00

IN THE UNITED STATES PATENT AND TRADEMARK OFFICE

In re Application of:	)	
ZHANG, Hongmei et al.	)	Group Art Unit: 2823
Application No.: 10/101,863	)	Examiner: ESTRADA, Michelle
Filed: March 16, 2002	)	
For: BIASED PULSE DC REACTIVE SPUTTERING OF OXIDE FILMS	)	Confirmation No.: 6938

**MAIL STOP AMENDMENT**

Commissioner for Patents  
P.O. Box 1450  
Alexandria, VA 22313-1450

Sir:

**AMENDMENT AND RESPONSE TO OFFICE ACTION**

In reply to the Office Action mailed January 13, 2005, the period for response having been extended to June 13, 2005 by a request for extension of 2 months with the Commissioner being authorized to charge the requisite fee to our Deposit Account No. 06-0916, please amend the above-identified application as follows:

**Amendments to the Claims** are reflected in the listing of claims in this paper.

**Remarks/Arguments** follow the amendment sections of this paper.

**AMENDMENTS TO THE CLAIMS:**

This listing of claims will replace all prior versions and listings of claims in the application:

1. (Currently amended) A method of depositing a film on a substrate, comprising:  
  
    providing pulsed DC power through a filter to a target;  
  
    providing RF bias power to a substrate positioned opposite the target; and  
  
    providing process gas between the target and the substrate,  
  
    wherein the filter protects a pulsed DC power supply from the bias power, and  
  
    wherein a plasma is created between the target and the substrate.
2. (Original): The method of Claim 1, further including holding the temperature of the substrate substantially constant.
3. (Original): The method of Claim 1, wherein providing pulsed DC power through the filter includes supplying up to about 10 kW of power at a frequency of between about 40 kHz and about 350 kHz and a reverse time pulse between about 1.3 and 5  $\mu$ s.
4. (Original): The method of Claim 1, wherein providing bias power to the substrate includes supplying up to 1000 W of RF power to the substrate.
5. (Original): The method of Claim 4, wherein the filter is a band reject filter at the frequency of the bias power.
6. (Original): The method of claim 4, wherein the bias power is zero.
7. (Original): The method of Claim 1, wherein the film is an upper cladding layer of a waveguide structure and the bias power is optimized to provide planarization.
8. (Original): The method of Claim 1, wherein the process gas includes a mixture of Oxygen and Argon.

9. (Original): The method of Claim 9, wherein the Oxygen flow is adjusted to adjust the index of refraction of the film.
10. (Original): The method of Claim 8, wherein the process gas further includes nitrogen.
11. (Original): The method of Claim 1, wherein providing pulsed DC power to a target includes providing pulsed DC power to a target which has an area larger than that of the substrate.
12. (Original): The method of Claim 1, further including uniformly sweeping the target with a magnetic field.
13. (Original): The method of Claim 12, wherein uniformly sweeping the target with a magnetic field includes sweeping a magnet in one direction across the target where the magnet extends beyond the target in the opposite direction.
14. (Currently amended): The method of Claim 1, further including depositing a film on the backside of the target [[12]].
- 15.-19. (Canceled).
20. (Currently Amended): A method of depositing a film on a substrate, comprising:
- conditioning a target;
  - preparing the substrate;
  - adjusting a RF bias power to the substrate;
  - setting a process gas flow; and
  - applying pulsed DC power to the target through a filter to create a plasma and deposit the film.
21. (Original): The method of Claim 20, wherein conditioning the target includes sputtering with the target in a metallic mode to remove the surface of the target and sputtering with the target in poisonous mode to prepare the surface.

22. (Original): The method of Claim 21, wherein setting the process gas flow includes adjusting constituents in order to adjust the index of refraction of the film.

23. (Original): The method of Claim 21, wherein applying pulsed DC power includes setting the frequency in order to adjust the index of refraction of the film.

24. (Original): The method of Claim 21, further including adjusting a temperature of the substrate in order to adjust the index of refraction of the film.

25.-39. (Canceled).

## REMARKS

Claims 15-19 and 25-39 were previously withdrawn from consideration in this application and canceled. Claims 1-13 and 20-24 are being considered in the present application. The Examiner has rejected claims 1-13 and 20 and has objected to claims 7, 14 and 21-24. Claims 1, 14, and 20 have been amended in this Amendment.

### Claim Objections

The Examiner has objected to claim 14 because “in line 2, it appears that ‘12’ should be deleted.” Applicants have amended claim 14 accordingly.

### Claim Rejections under 35 USC § 103

The Examiner has rejected claims 1-13 and 20 under 35 U.S.C. 103(a) as being unpatentable over the combination of Le et al. (2003/0077914) and Fukui et al. (5,755,938). The Examiner has rejected Applicant’s reasoning and has reiterated this rejection. Applicants herein traverse the Examiner’s further comments.

#### 1. Claims 1-13 and 20 are allowable over Le and Fukui because the combination of Le and Fukui does not teach all of the elements of these claims

Claim 1 recites “providing pulsed DC power through a filter to a target,” “providing RF bias power to a substrate,” and “wherein a plasma is created between the target and the substrate” Claim 20 recites “adjusting a RF bias power to the substrate” and “applying pulsed DC power to the target through a filter to create a plasma and deposit the film.” As explained more fully in the Response filed on July 23, 2004, the combination of Le and Fukui does not

teach providing pulsed DC power to the target to create a plasma and a RF bias power to the substrate.

*The teachings of Le*

Le teaches a processing chamber that supplies power, for example pulsed DC power, to a target (*See, e.g., Le, par. 0070, Figure 3*). As described in *Le*, the PVD chamber “may also have a shield 20 to protect a wall 12 of the chamber 36a from sputtered material, and typically, to also serve as an anode grounding plane.” *Id.* The shield is either electrically floating or grounded.

*Id.* The target is coupled to the power source. *Id.*

Therefore, as described in *Le*, a pulsed DC power supply is connected to the target. No bias is applied to the substrate as is suggested by the Examiner. (*See, OA, pgs. 2*). At most, *Le* teaches that “shield 20 is electrically floating or grounded,” (*Le, par. 0070*), which is not a bias as claimed in claims 1 and 20 of the present application, and certainly not an RF bias.

*The Examiner’s comments regarding Le*

The Examiner, in the response to Applicant’s previous submission, states that

Applicant argues that *Le et al.* do not disclose a bias applied to the substrate. However, Applicant is directed to Page 5, lines 13-14, wherein *Le et al.* disclose applying a RF energy (bias) to the gas supplied to the substrate.

(Office Action, page 5). *Le*, however, does not teach or imply energizing the gas with RF energy AND utilization of a pulsed DC power supply. *Le* teaches either energizing the gas with RF energy or energizing the gas with pulsed DC power. Further, *Le* teaches creating a plasma by application of RF power and not biasing the substrate by application of RF power, as is suggested by the Examiner.



As taught in Le, “[t]he multi-chamber platform 100 has at least one PVD chamber 36a, as for example illustrated in FIG. 3, to sputter deposit a titanium oxide (TiO<sub>x</sub>) layer 210, on the substrate 16.” (Le, par. 0066). In the description of the chamber for depositing the titanium oxide, Le teaches that “[t]he PVD chamber 36a further comprises a sputtering target 14 comprising titanium, facing the substrate 16.” (Le, par. 0070). Further, “[t]he target 14 is electrically isolated from the chamber 36a and is connected to a voltage source, such as a pulsed DC power source 22, but which may also be other types of voltage sources.” *Id.* Further, Le explains that “[t]he electric field generated in the chamber 36a from the voltage applied to the sputtering target 14 energizes the sputtering gas to form a plasma that sputters off the target material.” *Id.* Therefore, in the teachings of Le, pulsed DC power may be supplied to the target in the deposition of titanium oxide. Also, as discussed in Le, energizing the sputter gas creates the plasma, it does not bias the substrate as suggested by the Examiner’s comments above.

Le further states that “[a]n advantage of the present process is that a number of steps for forming a stacked layer comprising the anti-reflective coating 205 may be carried out in a single PVD sputtering chamber 36a.” (Le, par. 0074) Le further states that

[f]or example, the substrate 16 need not be transferred to different chambers when forming an anti-reflective coating 205 comprising multiple layers of, for example, titanium 230, titanium nitride 220, and titanium oxide 210. In one example, prior to forming the titanium oxide layer 210, the same chamber 36a is used to deposit an elemental titanium layer 230 on the substrate 16 using a sputtering gas comprising substantially only argon, and by maintaining the target at suitable voltage levels which may include DC or RF bias levels.

(Le, par. 0074). Therefore, Le teaches utilizing multiple chambers to form a stacked layer system and teaches utilizing different techniques in the same chamber for deposition of different layers.

Additionally, Le teaches another example of “a stacked layer 200 fabricated according to the present invention . . . having a diffusion barrier layer 255, a conductor layer 240, and an overlying anti-reflective coating 205 comprising a titanium layer 230 and a titanium oxide layer 210, or only a titanium oxide layer 210 . . . .” (Le, par. 0075) In forming this structure, Le teaches that “[t]he diffusion barrier layer 255 comprising layers of titanium 260 and titanium nitride 250 may be formed on the substrate 16 in the PVD chamber 36a or in one of the other chambers 36, by for example, using a sputtering target comprising titanium, introducing a sputtering gas comprising argon to form the titanium layer 260, or argon and nitrogen to form the titanium nitride layer 250, and energizing the gas by capacitively coupling RF energy to the gas.” *Id.* Therefore, the layer is RF sputtered onto the substrate. The RF power is not supplied to the gas to create a bias on the substrate, but rather to create the plasma in the gas. Further, Le teaches that “[t]hereafter, the substrate 16 is transferred to the chamber 36a to form an anti-reflective coating 205 comprising various layers that include a titanium oxide layer 210, on the conductor layer 240.” *Id.*

Therefore, the RF power is utilized in sputtering one film, and Pulsed DC power is utilized to deposit another film, the titanium oxide layer 210. Le does not teach utilizing both RF and pulsed DC powers in the same system. Le does not teach the combination of providing pulsed DC power to the target and a bias power to the substrate as was suggested by the Examiner.

*The Teachings of Fukui et al.*

As is more fully explained in the Response to Office Action filed on July 23, 2004, Fukui et al. does not cure the defects in the teachings of Le. Fukui teaches an RF sputtering chamber and not a pulsed-DC PVD chamber.

Fukui teaches a deposition chamber where an RF power supply is coupled to the target through a matching circuit and a second RF power supply is coupled to the substrate through a second matching circuit. (*See, e.g.*, Fukui, col. 6, lines 19-41). The matching circuits are configured so that reflected waves back to the power supplies are eliminated. *Id.* Further, a DC power supply (NOT a pulsed DC power supply) is coupled to the target through a low-pass filter. *Id.* As taught in Fukui, “[t]he band-pass filter 27 serves to adjust the circuit impedance to have an infinite value so that no RF waves are superposed on a DC power from the DC power supply 28.” (Fukui, col. 6, lines 34-37). Utilizing this arrangement, Fukui claims that “[t]he film manufacturing apparatus shown in FIG. 1 can deposit three thin films (e.g., a gate insulating film, a semiconductor film and an ohmic contact layer) successively in the single deposition chamber 10.” (Fukui, col. 6, lines 62-65).

As a result, Fukui only teaches RF plasma deposition processes and not a pulsed DC plasma deposition process. Further, Fukui only teaches a low pass filter coupled between a target bias DC power supply and the target. The DC power supply is simply a low power bias supply and is not a pulsed DC power supply that applies sufficient power to the target to create the plasma and sputter material from the target. The filter taught by Fukui is provided to protect a simple low power DC supply utilized for biasing the target and would not be applicable to such a pulsed DC power supply utilized for creating a plasma and sputtering material from the target.

Further, Utilization of a low pass filter with a pulsed DC power supply would also block the output power of the pulsed DC power supply.

*The Examiner's comments regarding Fukui*

The Examiner, in the response to Applicant's previous submission, states that

Applicant argues that Fukui does not teach a pulsed DC power supply. However, Fukui was not relied on upon for that purpose. Fukui teaches supplying power from a DC supply through a filter to the target. Fukui was relied on for the use of a filter to supply a power to the target.

(Office Action, page 6). As explained further above, the DC power supply and filter taught in Fukui is a low power bias supply and is not a pulsed DC power supply sufficient to create a plasma and sputter material from the target.

*The combination of Le and Fukui*

The combination of Le and Fukui does not teach "providing pulsed DC power through a filter to a target," "providing RF bias power to a substrate," and "wherein a plasma is created between the target and the substrate," as is recited in Claim 1, or "adjusting a bias power to the substrate" and "applying pulsed DC power to the target through a filter to create a plasma and deposit the film," as is recited in Claim 20. In particular, as is discussed above, even the combined teachings of Le and Fukui do not teach the combination of providing pulsed DC power to the target to create a plasma and an RF bias power to the substrate.

2. Claims 1-13 and 20 are allowable over Le and Fukui because there is no motivation to combine Le and Fukui as is suggested by the Examiner

As more fully discussed in the Response to Office Action filed on July 23, 2004, there is no motivation to combine Le and Fukui as is suggested by the Examiner. Le teaches a pulsed DC PVD system and Fukui teaches an RF based PVD system. The differences between those technologies is great. The use of a DC bias power supply to bias the target in an RF PVD system does not, in any way, imply a pulsed DC PVD system, as is claimed in claims 1 and 20.

The Examiner simply states that “[i]t would have been within the scope of one of ordinary skill in the art to combine the teachings of Le et al. and Fukui et al. to enable the use of a DC power supply through a filter to be used in the process of Le et al. to adjust the impedance to have an infinite value so that no RF waves are superposed on a DC power form [sic] the DC power supply (Col. 6, lines 32-37).” (Office Action of July 23, 2004, page 5). However, Le utilizes a DC power supply for biasing the target and not for generating a plasma for deposition of a material. Therefore, it would not be obvious to one skilled in the art to apply a filter provided for a DC power supply utilized for biasing a target to protect a much higher powered pulsed DC power supply that is utilized in the plasma generation.

Fukui teaches an RF power supply for creating the plasma and sputtering material from the target. There is no suggestion in Fukui that a pulsed DC power supply can be substituted for the RF power supply coupled to the target, nor would one skilled in the art be inclined to replace that RF power supply of Fukui with a pulsed DC power supply. Further, there is no suggestion in Le to substitute a pulsed DC supply for an RF power supply. Placing the low pass filter taught by Fukui between the pulsed DC power supply and the target of Le would be inoperative

because, assuming the filter survived the power requirements, the filter would not pass the pulsed DC power to the target.

As discussed above, therefore, there is no motivation for one skilled in the art to combine the references Le and Fukui in the fashion suggested by the Examiner.

*The Examiner's further comments regarding obviousness*

The Examiner, in the response to Applicant's previous submissions, states that

Applicant argues that utilizing a filter provided for a DC power supply is not obvious and may not be necessary in the system taught by Le because of the lack of a bias. However, Le discloses applying a bias to energize the gas being applied to the substrate, as explained above. Therefore, a filter may be used to provide the pulsed DC power through the filter since a bias is being applied.

(Office Action, page 6). However, as discussed above, Le does not teach applying both a pulsed DC power and RF power to the gas. Le teaches utilizing pulsed DC power for one process and RF power for a separate process, but not the two together. Further, application of RF power to the gas is not a bias, but rather a separate method of generating the plasma (exciting the gas) and sputtering material from the target. Therefore, there is no need to provide a filter between the pulsed DC power supply and the target as suggested by the Examiner. Furthermore, the low pass filter taught by Fukui would not be a suitable filter for that purpose as it would also block the pulsed DC power generated by the pulsed DC power supply from reaching the target.

The Examiner further states that

Applicant argues that there is no suggestion in Fukui that a pulsed DC power supply can be substituted for the RF power supply coupled to the target, nor would one skilled in the art be inclined to replace that RF power supply with a pulsed DC power supply. However, the Examiner is not substituting the pulsed DC power supply for the RF power supply coupled to the target. The

rejection is based on utilizing the filter of Fukui to be used in the pulsed DC power supply of Le.

(Office Action, pgs. 6-7). As discussed above, the low pass filter taught by Fukui is inapplicable for use with a pulsed DC power supply. The filter itself would block the power generated by the pulsed DC power supply. Furthermore, the DC power supply taught by Fukui is only for the purpose of biasing the target and does not generate a plasma or sputter material from the target, as does the pulsed DC power supply taught by Le. Those are two very different functions. One skilled in the art would not be inclined to utilize the filter taught by Fukui as is suggested by the Examiner.

Therefore, claims 1 and 20 are not obvious from the references Le and Fukui. Claims 2-13 depend from claim 1 and are therefore allowable for at least the same reasons as is claim 1. The Examiner's comments with regard to claims 2-13 are rendered mute by this discussion and therefore Applicant's neither comments on nor agrees with those comments.

#### **Allowable Subject Matter**

The Examiner has objected to claims 7, 14 and 21-24 "as being dependent upon a rejected base claim, but would be allowable if rewritten in independent form including all of the limitations of the base claim and any intervening claims." (OA, page 5).

#### **Request for Interview**

In the event that the Examiner persists in rejecting any of claims 1-13 and 20, Applicant requests an interview with the Examiner to discuss those claims and the prior art. The Examiner can contact the undersigned at 650-849-6622 in order to arrange a suitable time for such an interview.

**Conclusion**

In view of the foregoing amendments and remarks, Applicant respectfully requests reconsideration and reexamination of this application and the timely allowance of the pending claims.

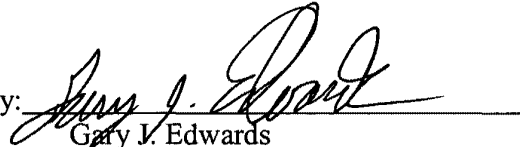
Please grant any extensions of time required to enter this response and charge any additional required fees to our deposit account 06-0916.

Respectfully submitted,

FINNEGAN, HENDERSON, FARABOW,  
GARRETT & DUNNER, L.L.P.

Dated: June 10, 2005

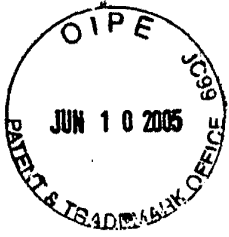
By:



Gary J. Edwards  
Reg. No. 41,008

**EXPRESS MAIL LABEL NO.  
EV 724128283 US**





PATENT  
Customer No. 22,852  
Attorney Docket No. 9140.0016-00

IN THE UNITED STATES PATENT AND TRADEMARK OFFICE

In re Application of: )  
)  
ZHANG, Hongmei et al. ) Group Art Unit: 2823  
)  
Application No.: 10/101,863 ) Examiner: ESTRADA, Michelle  
)  
Filed: March 16, 2002 )  
)  
For: BIASED PULSE DC REACTIVE ) Confirmation No.: 6938  
SPUTTERING OF OXIDE FILMS )

**MAIL STOP AMENDMENT**  
Commissioner for Patents  
P.O. Box 1450  
Alexandria, VA 22313-1450

Sir:

**PETITION FOR EXTENSION OF TIME**

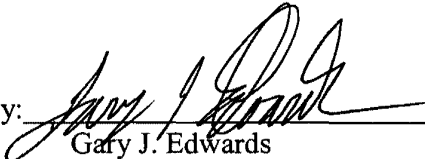
Applicants petition for a two month extension of time to reply to the Office action of January 13, 2005. The Commissioner is hereby authorized to charge the fee of \$450.00 to our Deposit Account No. 06-0916.

Please grant any extensions of time required to enter this response and charge any additional required fees to our deposit account 06-0916.

Respectfully submitted,

FINNEGAN, HENDERSON, FARABOW,  
GARRETT & DUNNER, L.L.P.

Dated: June 10, 2005

By:   
Gary J. Edwards  
Reg. No. 41,008

**EXPRESS MAIL LABEL NO.  
EV 724128283 US**

06/15/2005 WABDELRI 00000123 060916 10101863  
01 FC:1252 450.00 DA

Under the Paperwork Reduction Act of 1995, no persons are required to respond to a collection of information unless it displays a valid OMB control number.

PATENT APPLICATION FEE DETERMINATION RECORD Substitute for Form PTO-875					Application or Docket Number <b>10/101863</b>						
<b>CLAIMS AS FILED – PART I</b>					<b>SMALL ENTITY</b>		<b>OR</b>		<b>OTHER THAN SMALL ENTITY</b>		
(Column 1)		(Column 2)									
FOR	NUMBER FILED	NUMBER EXTRA			RATE	FEE			RATE	FEE	
BASIC FEE (37 CFR 1.16(a))						\$ _____				\$ _____	
TOTAL CLAIMS (37 CFR 1.16(c))		minus 20 = *			X \$ _____ =				X \$ _____ =		
INDEPENDENT CLAIMS (37 CFR 1.16(b))		minus 3 = *			X \$ _____ =				X \$ _____ =		
MULTIPLE DEPENDENT CLAIM PRESENT (37 CFR 1.16(d))					+ \$ _____ =				+ \$ _____ =		
* If the difference in column 1 is less than zero, enter "0" in column 2.					TOTAL				TOTAL		
<b>CLAIMS AS AMENDED – PART II</b>					<b>SMALL ENTITY</b>		<b>OR</b>		<b>OTHER THAN SMALL ENTITY</b>		
(Column 1)		(Column 2)		(Column 3)							
AMENDMENT A	CLAIMS REMAINING AFTER AMENDMENT		HIGHEST NUMBER PREVIOUSLY PAID FOR	PRESENT EXTRA	RATE	ADDITIONAL FEE			RATE	ADDITIONAL FEE	
	Total (37 CFR 1.16(c))	19	Minus **	20	X \$ 25 =				X \$ 50 =		
	Independent (37 CFR 1.16(b))	2	Minus ***	3	X \$ 100 =				X \$ 200 =		
	FIRST PRESENTATION OF MULTIPLE DEPENDENT CLAIM (37 CFR 1.16(d))					+ \$ 180 =				+ \$ 360 =	
					TOTAL ADD'L FEE				TOTAL ADD'L FEE		
AMENDMENT B	CLAIMS REMAINING AFTER AMENDMENT		HIGHEST NUMBER PREVIOUSLY PAID FOR	PRESENT EXTRA	RATE	ADDITIONAL FEE			RATE	ADDITIONAL FEE	
	Total (37 CFR 1.16(c))		Minus **		X \$ 25 =				X \$ 50 =		
	Independent (37 CFR 1.16(b))		Minus ***		X \$ 100 =				X \$ 200 =		
	FIRST PRESENTATION OF MULTIPLE DEPENDENT CLAIM (37 CFR 1.16(d))					+ \$ 180 =				+ \$ 360 =	
					TOTAL ADD'L FEE				TOTAL ADD'L FEE		
AMENDMENT C	CLAIMS REMAINING AFTER AMENDMENT		HIGHEST NUMBER PREVIOUSLY PAID FOR	PRESENT EXTRA	RATE	ADDITIONAL FEE			RATE	ADDITIONAL FEE	
	Total (37 CFR 1.16(c))		Minus **		X \$ 25 =				X \$ 50 =		
	Independent (37 CFR 1.16(b))		Minus ***		X \$ 100 =				X \$ 200 =		
	FIRST PRESENTATION OF MULTIPLE DEPENDENT CLAIM (37 CFR 1.16(d))					+ \$ 180 =				+ \$ 360 =	
					TOTAL ADD'L FEE				TOTAL ADD'L FEE		

\* If the entry in column 1 is less than the entry in column 2, write "0" in column 3.  
 \*\* If the "Highest Number Previously Paid For" IN THIS SPACE is less than 20, enter "20".  
 \*\*\* If the "Highest Number Previously Paid For" IN THIS SPACE is less than 3, enter "3".  
 The "Highest Number Previously Paid For" (Total or Independent) is the highest number found in the appropriate box in column 1.

This collection of information is required by 37 CFR 1.16. The information is required to obtain or retain a benefit by the public which is to file (and by the USPTO to process) an application. Confidentiality is governed by 35 U.S.C. 122 and 37 CFR 1.14. This collection is estimated to take 12 minutes to complete, including gathering, preparing, and submitting the completed application form to the USPTO. Time will vary depending upon the individual case. Any comments on the amount of time you require to complete this form and/or suggestions for reducing this burden, should be sent to the Chief Information Officer, U.S. Patent and Trademark Office, U.S. Department of Commerce, P.O. Box 1450, Alexandria, VA 22313-1450. DO NOT SEND FEES OR COMPLETED FORMS TO THIS ADDRESS. SEND TO: Commissioner for Patents, P.O. Box 1450, Alexandria, VA 22313-1450.

If you need assistance in completing the form, call 1-800-PTO-9199 and select option 2.



UNITED STATES PATENT AND TRADEMARK OFFICE

UNITED STATES DEPARTMENT OF COMMERCE  
United States Patent and Trademark Office  
Address: COMMISSIONER FOR PATENTS  
P.O. Box 1450  
Alexandria, Virginia 22313-1450  
www.uspto.gov

APPLICATION NO.	FILING DATE	FIRST NAMED INVENTOR	ATTORNEY DOCKET NO.	CONFIRMATION NO.
10/101,863	03/16/2002	Hongmei Zhang	M-12245 US	6938
22852	7590	07/01/2005	EXAMINER	
FINNEGAN, HENDERSON, FARABOW, GARRETT & DUNNER LLP 901 NEW YORK AVENUE, NW WASHINGTON, DC 20001-4413			ESTRADA, MICHELLE	
			ART UNIT	PAPER NUMBER
			2823	

DATE MAILED: 07/01/2005

Please find below and/or attached an Office communication concerning this application or proceeding.

**Advisory Action  
Before the Filing of an Appeal Brief**

Application No. 10/101,863	Applicant(s) ZHANG ET AL.	
Examiner Michelle Estrada	Art Unit 2823	

--The MAILING DATE of this communication appears on the cover sheet with the correspondence address --

THE REPLY FILED 10 June 2005 FAILS TO PLACE THIS APPLICATION IN CONDITION FOR ALLOWANCE.

1.  The reply was filed after a final rejection, but prior to or on the same day as filing a Notice of Appeal. To avoid abandonment of this application, applicant must timely file one of the following replies: (1) an amendment, affidavit, or other evidence, which places the application in condition for allowance; (2) a Notice of Appeal (with appeal fee) in compliance with 37 CFR 41.31; or (3) a Request for Continued Examination (RCE) in compliance with 37 CFR 1.114. The reply must be filed within one of the following time periods:

- a)  The period for reply expires \_\_\_\_\_ months from the mailing date of the final rejection.
- b)  The period for reply expires on: (1) the mailing date of this Advisory Action, or (2) the date set forth in the final rejection, whichever is later. In no event, however, will the statutory period for reply expire later than SIX MONTHS from the mailing date of the final rejection.

Examiner Note: If box 1 is checked, check either box (a) or (b). ONLY CHECK BOX (b) WHEN THE FIRST REPLY WAS FILED WITHIN TWO MONTHS OF THE FINAL REJECTION. See MPEP 706.07(f).

Extensions of time may be obtained under 37 CFR 1.136(a). The date on which the petition under 37 CFR 1.136(a) and the appropriate extension fee have been filed is the date for purposes of determining the period of extension and the corresponding amount of the fee. The appropriate extension fee under 37 CFR 1.17(a) is calculated from: (1) the expiration date of the shortened statutory period for reply originally set in the final Office action; or (2) as set forth in (b) above, if checked. Any reply received by the Office later than three months after the mailing date of the final rejection, even if timely filed, may reduce any earned patent term adjustment. See 37 CFR 1.704(b).

NOTICE OF APPEAL

2.  The Notice of Appeal was filed on \_\_\_\_\_. A brief in compliance with 37 CFR 41.37 must be filed within two months of the date of filing the Notice of Appeal (37 CFR 41.37(a)), or any extension thereof (37 CFR 41.37(e)), to avoid dismissal of the appeal. Since a Notice of Appeal has been filed, any reply must be filed within the time period set forth in 37 CFR 41.37(a).

AMENDMENTS

- 3.  The proposed amendment(s) filed after a final rejection, but prior to the date of filing a brief, will not be entered because
  - (a)  They raise new issues that would require further consideration and/or search (see NOTE below);
  - (b)  They raise the issue of new matter (see NOTE below);
  - (c)  They are not deemed to place the application in better form for appeal by materially reducing or simplifying the issues for appeal; and/or
  - (d)  They present additional claims without canceling a corresponding number of finally rejected claims.

NOTE: Upon cursory review, the proposed amendment to claims 1 and 20 and the arguments filed 6/10/05 do not clearly place the case in condition for allowance. Applicant's arguments rely on the proposed amendment which has not been entered. The proposed amendment would change the scope of claims 1 and 20 raising new issues requiring further consideration and/or search. (See 37 CFR 1.116 and 41.33(a)).

- 4.  The amendments are not in compliance with 37 CFR 1.121. See attached Notice of Non-Compliant Amendment (PTOL-324).
- 5.  Applicant's reply has overcome the following rejection(s): \_\_\_\_\_.
- 6.  Newly proposed or amended claim(s) \_\_\_\_\_ would be allowable if submitted in a separate, timely filed amendment canceling the non-allowable claim(s).
- 7.  For purposes of appeal, the proposed amendment(s): a)  will not be entered, or b)  will be entered and an explanation of how the new or amended claims would be rejected is provided below or appended.

The status of the claim(s) is (or will be) as follows:

Claim(s) allowed: none.  
 Claim(s) objected to: 7, 14 and 21-24.  
 Claim(s) rejected: 1-13 and 20.  
 Claim(s) withdrawn from consideration: none.

AFFIDAVIT OR OTHER EVIDENCE

- 8.  The affidavit or other evidence filed after a final action, but before or on the date of filing a Notice of Appeal will not be entered because applicant failed to provide a showing of good and sufficient reasons why the affidavit or other evidence is necessary and was not earlier presented. See 37 CFR 1.116(e).
- 9.  The affidavit or other evidence filed after the date of filing a Notice of Appeal, but prior to the date of filing a brief, will not be entered because the affidavit or other evidence failed to overcome all rejections under appeal and/or appellant fails to provide a showing of a good and sufficient reasons why it is necessary and was not earlier presented. See 37 CFR 41.33(d)(1).
- 10.  The affidavit or other evidence is entered. An explanation of the status of the claims after entry is below or attached.

REQUEST FOR RECONSIDERATION/OTHER

- 11.  The request for reconsideration has been considered but does NOT place the application in condition for allowance because: \_\_\_\_\_.
- 12.  Note the attached Information Disclosure Statement(s). (PTO/SB/08 or PTO-1449) Paper No(s). \_\_\_\_\_
- 13.  Other: \_\_\_\_\_.

*Michelle Estrada*  
 Patent Examiner  
 AU 2823

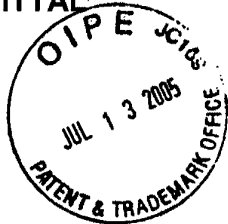


7-15-05

*Handwritten initials/signature*

### REQUEST FOR CONTINUED EXAMINATION (RCE) TRANSMITTAL

Address to:  
**Mail Stop RCE**  
Commissioner for Patents  
P.O. Box 1450  
Alexandria, VA 22313-1450



Application Number: 10/101,863	Confirmation Number: 6938
Filing Date: March 16, 2002	
First Named Inventor: ZHANG, Hongmei	
Group Art Unit: 2823	
Examiner: ESTRADA, Michelle	
Attorney Docket Number: 9140.0016-00	
Attorney Customer Number: 22,852	

This is a Request for Continued Examination (RCE) under 37 C.F.R. § 1.114 of the above-identified application.

Request for Continued Examination (RCE) practice under 37 C.F.R. § 1.114 does not apply to any utility or plant application filed prior to June 8, 1995, or to any design application.

1. Submission required under 37 C.F.R. § 1.114: **Note: If the RCE is proper, any previously filed unentered amendments and amendments enclosed with the RCE will be entered in the order in which they were filed unless applicant instructs otherwise.** If applicant does not wish to have any previously filed unentered amendment(s) entered, application must request non-entry of such amendment.

a.  Previously submitted. If a final Office action is outstanding, any amendments filed after the final Office action may be considered as a submission even if this box is not checked.

i.  Consider the arguments in the Appeal Brief or Reply Brief previously filed on \_\_\_\_\_.

ii.  Other Amendment and Response to Office Action dated June 10, 2005.

b.  **DO NOT ENTER** the amendment(s) previously filed on \_\_\_\_\_. An alternate submission is attached.

c.  Enclosed submission: .

i.  Amendment/Reply

ii.  Affidavit(s)/Declaration(s)

iii.  Information Disclosure Statement

iv.  Other \_\_\_\_\_

2. Miscellaneous

a.  Suspension of action on the above-mentioned application is requested under 37 C.F.R. § 1.103(c) for a period of months. (Period of suspension shall not exceed 3 months; fee under 37 C.F.R. § 1.17(i) required.)

b.  Other \_\_\_\_\_

3. Fees

a.  The filing fee is calculated as follows:

i.  \$790.00 RCE fee required under 37 C.F.R. § 1.17(e)

ii.  Petition for extension of time for (3 Months) \$1,020.00 - \$450.00 = \$570.00

iii.  Other

b.  The Commissioner is hereby authorized to charge the total fee of \$1,360.00 to Deposit Account No. 06-0916.

c.  The Commissioner is authorized to charge any deficiencies in the filing fees, or credit any overpayments to Deposit Account No. 06-0916.

**Signature of Applicant, Attorney, or Agent Required**

Name: Gary J. Edwards	Reg. No.: 41,008
Signature: <i>Gary J. Edwards</i>	Date: July 13, 2005

EXPRESS MAIL LABEL NO.  
EV 727732935 US

10101863  
060916  
07/18/2005 WABDELRI 00000085  
790.00 DA  
02 FC:1801



PATENT  
Customer No. 22,852  
Attorney Docket No. 9140.0016-00

IN THE UNITED STATES PATENT AND TRADEMARK OFFICE

In re Application of: )  
)  
ZHANG, Hongmei et al. ) Group Art Unit: 2823  
)  
Application No.: 10/101,863 ) Examiner: ESTRADA, Michelle  
)  
Filed: March 16, 2002 )  
)  
For: BIASED PULSE DC REACTIVE ) Confirmation No.: 6938  
SPUTTERING OF OXIDE FILMS )

**Mail Stop RCE**  
Commissioner for Patents  
P.O. Box 1450  
Alexandria, VA 22313-1450

Sir:

**INFORMATION DISCLOSURE STATEMENT UNDER 37 C.F.R. § 1.97(b)**

Pursuant to 37 C.F.R. §§ 1.56 and 1.97(b), applicants bring to the attention of the Examiner the documents on the attached listing. This Information Disclosure Statement is being filed before the mailing date of a first Office Action after the filing of a Request for Continued Examination in the above-referenced application. Applicants respectfully request that the Examiner consider the listed documents and indicate that they were considered by making appropriate notations on the attached form.

Based on reasonable inquiry, no document listed in this Information Disclosure Statement was cited in a communication from a foreign patent office in a counterpart foreign application, and no document listed in this Information Disclosure Statement was known to any individual

designated in 37 C.F.R. § 1.56(c) more than three months prior to the filing date of this Information Disclosure Statement.]

A copy of the listed non-patent literature document is attached. Copies of the U.S. patents and patent publications are not enclosed.

Applicants respectfully request that the Examiner consider the listed documents and indicate that they were considered by making appropriate notations on the attached form.

This submission does not represent that a search has been made or that no better art exists and does not constitute an admission that each or all of the listed documents are material or constitute "prior art." If the Examiner applies any of the documents as prior art against any claims in the application and applicants determine that the cited documents do not constitute "prior art" under United States law, applicant reserves the right to present to the office the relevant facts and law regarding the appropriate status of such documents.

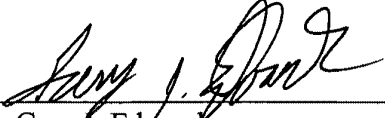
Applicants further reserve the right to take appropriate action to establish the patentability of the disclosed invention over the listed documents, should one or more of the documents be applied against the claims of the present application.

If there is any fee due in connection with the filing of this Statement, please charge the fee to our Deposit Account No. 06-0916.

Respectfully submitted,

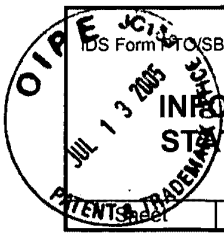
FINNEGAN, HENDERSON, FARABOW,  
GARRETT & DUNNER, L.L.P.

Dated: July 13, 2005

By:   
Gary J. Edwards  
Reg. No. 41,008

**EXPRESS MAIL LABEL NO.**  
**EV 727732935 US**





US Form PTO/SB/08: Substitute for form 1449A/PTO

**INFORMATION DISCLOSURE STATEMENT BY APPLICANT**

(Use as many sheets as necessary)

1 of 1

**Complete if Known**

Application Number	10/101,863
Filing Date	March 16, 2002
First Named Inventor	ZHANG, Hongmei
Art Unit	2823
Examiner Name	ESTRADA, Michelle
Attorney Docket Number	9140.0016-00

**U.S. PATENTS AND PUBLISHED U.S. PATENT APPLICATIONS**

Examiner Initials	Cite No. <sup>1</sup>	Document Number	Issue or Publication Date MM-DD-YYYY	Name of Patentee or Applicant of Cited Document	Pages, Columns, Lines, Where Relevant Passages or Relevant Figures Appear
		Number-Kind Code <sup>2</sup> (if known)			
		US-2004/0077161	04-22-2004	Chen et al.	
		US-2003/0175142	09-18-2003	Milonopoulou et al.	
		US-2003/0077914	04-24-2003	Le et al.	
		US-6,361,662	03-26-2002	Chiba et al.	
		US-6,281,142	08-28-2001	Basceri et al.	
		US-6,117,279	09-12-2000	Smolanoff et al.	

**Note: Submission of copies of U.S. Patents and published U.S. Patent Applications is not required.**

**FOREIGN PATENT DOCUMENTS**

Examiner Initials	Cite No. <sup>1</sup>	Foreign Patent Document	Publication Date MM-DD-YYYY	Name of Patentee or Applicant of Cited Document	Pages, Columns, Lines, Where Relevant Passages or Relevant Figures Appear	Translation <sup>6</sup>
		Country Code <sup>3</sup> Number <sup>4</sup> Kind Code <sup>5</sup> (if known)				

**NON PATENT LITERATURE DOCUMENTS**

Examiner Initials	Cite No. <sup>1</sup>	Include name of the author (in CAPITAL LETTERS), title of the article (when appropriate), title of the item (book, magazine, journal, serial, symposium, catalog, etc.), date, page(s), volume-issue number(s), publisher, city and/or country where published.	Translation <sup>6</sup>
		Office Action dated March 25, 2005, received in Application No. 10/954,182 (Attorney Docket No. 09140.0016-01000).	

Examiner Signature		Date Considered	
--------------------	--	-----------------	--

EXAMINER: Initial if reference considered, whether or not citation is in conformance with MPEP 609. Draw line through citation if not in conformance and not considered. Include copy of this form with next communication to applicant.

**EXPRESS MAIL LABEL NO.  
EV 727732935 US**



PATENT  
Customer No. 22,852  
Attorney Docket No. 9140.0016-00

THE UNITED STATES PATENT AND TRADEMARK OFFICE

In re Application of:	)	
	)	
ZHANG, Hongmei et al.	)	Group Art Unit: 2823
	)	
Application No.: 10/101,863	)	Examiner: ESTRADA, Michelle
	)	
Filed: March 16, 2002	)	
	)	
For: BIASED PULSE DC REACTIVE	)	Confirmation No.: 6938
SPUTTERING OF OXIDE FILMS	)	

**MAIL STOP RCE**  
Commissioner for Patents  
P.O. Box 1450  
Alexandria, VA 22313-1450

Sir:

**PETITION FOR EXTENSION OF TIME**

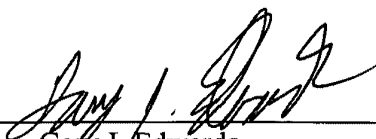
Applicants petition for a three month extension of time to reply to the Advisory Action of July 1, 2005. Applicants filed a Petition for Extension of Time on June 10, 2005, paying a fee of \$450.00. The fee of \$450.00 is subtracted from the fee of \$1,020.00 for a three month extension of time. Therefore, the Commissioner is hereby authorized to charge the remaining fee of \$570.00 to our Deposit Account No. 06-0916.

Please grant any extensions of time required to enter this response and charge any additional required fees to our deposit account 06-0916.

Respectfully submitted,

FINNEGAN, HENDERSON, FARABOW,  
GARRETT & DUNNER, L.L.P.

Dated: July 13, 2005

By:   
\_\_\_\_\_  
Gary J. Edwards  
Reg. No. 41,008

**EXPRESS MAIL LABEL NO.  
EV 727732935 US**

07/16/2005 WABDELRI 00000085 060916 10101863  
570.00 DA  
01 FC:1253



6-13-05

42-2875 \$  
ATC

PATENT  
Customer No. 22,852  
Attorney Docket No. 9140.0016-00

IN THE UNITED STATES PATENT AND TRADEMARK OFFICE

In re Application of:	)	
ZHANG, Hongmei et al.	)	Group Art Unit: 2823
Application No.: 10/101,863	)	Examiner: ESTRADA, Michelle
Filed: March 16, 2002	)	
For: BIASED PULSE DC REACTIVE SPUTTERING OF OXIDE FILMS	)	Confirmation No.: 6938

*Entered per ACE*

**MAIL STOP AMENDMENT**  
Commissioner for Patents  
P.O. Box 1450  
Alexandria, VA 22313-1450

Sir:

**AMENDMENT AND RESPONSE TO OFFICE ACTION**

In reply to the Office Action mailed January 13, 2005, the period for response having been extended to June 13, 2005 by a request for extension of 2 months with the Commissioner being authorized to charge the requisite fee to our Deposit Account No. 06-0916, please amend the above-identified application as follows:

**Amendments to the Claims** are reflected in the listing of claims in this paper.

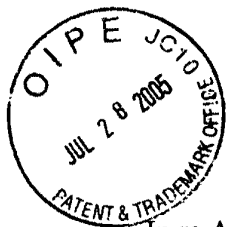
**Remarks/Arguments** follow the amendment sections of this paper.

*PM  
7/13/05*

08-01-05

1Fm

2823



PATENT  
Customer No. 22,852  
Attorney Docket No. 9140.0016-00

**IN THE UNITED STATES PATENT AND TRADEMARK OFFICE**

In re Application of:	)	
	)	
ZHANG, Hongmei et al.	)	Group Art Unit: 2823
	)	
Application No.: 10/101,863	)	Examiner: ESTRADA, Michelle
	)	
Filed: March 16, 2002	)	
	)	
For: BIASED PULSE DC REACTIVE	)	Confirmation No.: 6938
SPUTTERING OF OXIDE FILMS	)	

**MAIL STOP AMENDMENT**  
Commissioner for Patents  
P.O. Box 1450  
Alexandria, VA 22313-1450

Sir:

**SUPPLEMENTAL INFORMATION DISCLOSURE STATEMENT**  
**UNDER 37 C.F.R. § 1.97(b)**

Pursuant to 37 C.F.R. §§ 1.56 and 1.97(b), applicants bring to the attention of the Examiner the documents on the attached listing. This Information Disclosure Statement is being filed before the mailing date of a first Office Action after the filing of a Request for Continued Examination in the above-referenced application. Applicants respectfully request that the Examiner consider the listed documents and indicate that they were considered by making appropriate notations on the attached form.

Based on reasonable inquiry, no document listed in this Information Disclosure Statement was cited in a communication from a foreign patent office in a counterpart foreign application, and no document listed in this Information Disclosure Statement was known to any individual

designated in 37 C.F.R. § 1.56(c) more than three months prior to the filing date of this Information Disclosure Statement.

Copies of the listed foreign patents and non-patent literature documents are attached. Copies of the U.S. patents and patent publications are not enclosed.

Applicants respectfully request that the Examiner consider the listed documents and indicate that they were considered by making appropriate notations on the attached form.

This submission does not represent that a search has been made or that no better art exists and does not constitute an admission that each or all of the listed documents are material or constitute "prior art." If the Examiner applies any of the documents as prior art against any claims in the application and applicants determine that the cited documents do not constitute "prior art" under United States law, applicant reserves the right to present to the office the relevant facts and law regarding the appropriate status of such documents.

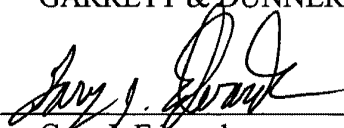
Applicants further reserve the right to take appropriate action to establish the patentability of the disclosed invention over the listed documents, should one or more of the documents be applied against the claims of the present application.

If there is any fee due in connection with the filing of this Statement, please charge the fee to our Deposit Account No. 06-0916.

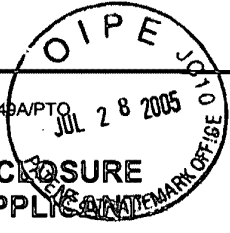
Respectfully submitted,

FINNEGAN, HENDERSON, FARABOW,  
GARRETT & DUNNER, L.L.P.

Dated: July 28, 2005

By:   
\_\_\_\_\_  
Gary J. Edwards  
Reg. No. 41,008

**EXPRESS MAIL LABEL NO.**  
**EV 727733065 US**



IDS Form PTO/SB/08: Substitute for form 1449A/PTO

**Complete if Known**

<b>INFORMATION DISCLOSURE STATEMENT BY APPLICANT</b>  <i>(Use as many sheets as necessary)</i>	Application Number	10/101,863
	Filing Date	March 16, 2002
	First Named Inventor	ZHANG, Hongmei
	Art Unit	2823
	Examiner Name	ESTRADA, Michelle
	Attorney Docket Number	9140.0016-00

Sheet 1 of 9

U.S. PATENTS AND PUBLISHED U.S. PATENT APPLICATIONS					
Examiner Initials	Cite No. <sup>1</sup>	Document Number	Issue or Publication Date MM-DD-YYYY	Name of Patentee or Applicant of Cited Document	Pages, Columns, Lines, Where Relevant Passages or Relevant Figures Appear
		Number-Kind Code <sup>2</sup> (if known)			
		US 2005/0006768 A1	01-13-2005	Narasimhan et al.	
		US 2005/0000794 A1	01-06-2005	Demaray et al.	
		US 2004/0259305 A1	12-23-2004	Demaray et al.	
		US 2004/0105644 A1	06-03-2004	Dawes	
		US 2003/0174391 A1	09-18-2003	Pan et al.	
		US 2003/0141186 A1	07-31-2003	Wang et al.	
		US 2003/0127319 A1	06-10-2003	Demaray et al.	
		US 2003/0097858 A1	05-29-2003	Strohhofer et al.	
		US 2002/0170821 A1	11-21-2002	Sandlin et al.	
		US 2001/041460 A1	11-15-2001	Wiggins	
		US 2001/0027159 A1	10-04-2001	Kaneyoshi	
		US 6,750,156 B2	06-15-2004	Le et al.	
		US 6,576,546 B2	06-10-2003	Gilbert et al.	
		US 6,444,750 B1	09-03-2002	Touhsaent	
		US 6,433,380 B2	08-13-2002	Shin	
		US 6,423,776 B1	07-23-2002	Akkapeddi et al.	
		US 6,416,598 B1	07-09-2002	Sircar	
		US 6,413,645 B1	07-02-2002	Graff et al.	
		US 6,365,319 B1	04-02-2002	Heath et al.	
		US 6,302,939 B1	10-16-2001	Rabin et al.	
		US 6,300,215 B1	10-09-2001	Shin	
		US 6,261,917 B1	07-17-2001	Quek et al.	
		US 6,248,640 B1	06-19-2001	Nam	
		US 6,232,242	05-15-2001	Hata et al.	
		US 6,214,660 B1	04-10-2001	Uemoto et al.	
		US 6,210,544 B1	04-03-2001	Sasaki	
		US 6,204,111 B1	03-20-2001	Uemoto et al.	
		US 6,198,217 B1	03-06-2001	Suzuki et al.	
		US 6,197,167 B1	03-06-2001	Tanaka	
		US 6,165,566	12-26-2000	Tropsha	

Examiner Signature	Date Considered
--------------------	-----------------

EXAMINER: Initial if reference considered, whether or not citation is in conformance with MPEP 609. Draw line through citation if not in conformance and not considered. Include copy of this form with next communication to applicant.

IDS Form PTO/SB/08: Substitute for form 1449A/PTO				<b>Complete if Known</b>	
<b>INFORMATION DISCLOSURE STATEMENT BY APPLICANT</b>  <i>(Use as many sheets as necessary)</i>				<i>Application Number</i>	10/101,863
				<i>Filing Date</i>	March 16, 2002
				<i>First Named Inventor</i>	ZHANG, Hongmei
				<i>Art Unit</i>	2823
				<i>Examiner Name</i>	ESTRADA, Michelle
Sheet	2	of	9	<i>Attorney Docket Number</i>	9140.0016-00

U.S. PATENTS AND PUBLISHED U.S. PATENT APPLICATIONS					
		US 6,157,765	12-05-2000	Bruce et al.	
		US 6,146,225	11-14-2000	Sheats et al.	
		US 6,106,933	08-22-2000	Nagai et al.	
		US 6,080,643	06-27-2000	Noguchi et al.	
		US 6,077,642	06-20-2000	Ogata et al.	
		US 6,071,323	06-06-2000	Kawaguchi	
		US 6,058,233	05-02-2000	Dragone	
		US 6,052,397	04-18-2000	Jeon et al.	
		US 6,051,296	04-18-2000	McCaulley et al.	
		US 6,046,081	04-04-2000	Kuo	
		US 6,004,660	12-21-1999	Topolski et al.	
		US 5,966,491	10-12-1999	DiGiovanni	
		US 5,952,778	09-14-1999	Haskal et al.	
		US 5,930,584	07-27-1999	Sun et al.	
		US 5,900,057	05-04-1999	Buchal et al.	
		US 5,882,946	03-16-1999	Otani	
		US 5,870,273	02-09-1999	Sogabe et al.	
		US 5,853,830	12-29-1998	McCaulley et al.	
		US 5,831,262	11-03-1998	Greywall et al.	
		US 5,811,177	09-22-1998	Shi et al.	
		US 5,771,562	06-30-1998	Harvey, III et al.	
		US 5,762,768	06-09-1998	Goy et al.	
		US 5,757,126	05-26-1998	Harvey, III et al.	
		US 5,738,731	04-14-1998	Shindo et al.	
		US 5,731,661	03-24-1998	So et al.	
		US 5,689,522	11-18-1997	Beach	
		US 5,686,360	11-11-1997	Harvey, III et al.	
		US 5,654,984	08-05-1997	Hershbarger et al.	
		US 5,607,789	03-04-1997	Treger et al.	
		US 5,591,520	01-07-1997	Migliorini et al.	
		US 5,563,979	10-08-1996	Bruce et al.	
		US 5,538,796	07-23-1996	Schaffer et al.	
Examiner Signature				Date Considered	

EXAMINER: Initial if reference considered, whether or not citation is in conformance with MPEP 609. Draw line through citation if not in conformance and not considered. Include copy of this form with next communication to applicant.

IDS Form PTO/SB/08: Substitute for form 1449A/PTO				<b>Complete if Known</b>	
<b>INFORMATION DISCLOSURE STATEMENT BY APPLICANT</b> <i>(Use as many sheets as necessary)</i>				Application Number	10/101,863
				Filing Date	March 16, 2002
				First Named Inventor	ZHANG, Hongmei
				Art Unit	2823
				Examiner Name	ESTRADA, Michelle
Sheet	3	of	9	Attorney Docket Number	9140.0016-00

U.S. PATENTS AND PUBLISHED U.S. PATENT APPLICATIONS					
		US 5,499,207	03-12-1996	Miki et al.	
		US 5,457,569	10-10-1995	Liou et al.	
		US 5,355,089	10-11-1994	Treger	
		US 5,309,302	05-03-1994	Vollmann	
		US 5,306,569	04-26-1994	Hiraki	
		US 5,303,319	04-12-1994	Ford et al.	
		US 5,296,089	03-22-1994	Chen et al.	
		US 5,173,271	12-22-1992	Chen et al.	
		US 5,119,460	06-02-1992	Bruce et al.	
		US 5,107,538	04-21-1992	Benton et al.	
		US 5,085,904	02-04-1992	Deak et al.	
		US 4,587,225	05-06-1986	Tsukuma et al.	
		RE 32,449	06-30-1987	Claussen	

**Note: Submission of copies of U.S. Patents and published U.S. Patent Applications is not required.**

FOREIGN PATENT DOCUMENTS							
Examiner Initials	Cite No. <sup>1</sup>	Foreign Patent Document		Publication Date MM-DD-YYYY	Name of Patentee or Applicant of Cited Document	Pages, Columns, Lines, Where Relevant Passages or Relevant Figures Appear	Translation <sup>6</sup>
		Country Code <sup>3</sup>	Number <sup>4</sup> Kind Code <sup>5</sup> (if known)				
		EP 1 189 080 A2	03-20-2002		Agere Systems Optoelectronics Guardian Corporation		
		EP 1 092 689 A1	04-18-2001		BPS Alzenau GmbH		
		EP 1068899 A1	01-17-2001		Nippon Sheet Glass Co., Ltd.		
		EP 0 639 655 A1	02-22-1995		Asahi Glass Co, Ltd.		
		EP 0 652 308 A2	10-13-1994		Mega Chips Corp.		
		EP 0 510 883 A2	10-28-1992		AT&T		
		JP 7-233469	09-05-1995		Asahi Glass Co, Ltd.		
		JP 2-054764 A2	02-23-1990		Leybold AG		
		WO 00/21898 A1	04-20-2000		Samsung Electronics Co.		

Examiner Signature		Date Considered	
--------------------	--	-----------------	--

EXAMINER: Initial if reference considered, whether or not citation is in conformance with MPEP 609. Draw line through citation if not in conformance and not considered. Include copy of this form with next communication to applicant.



IDS Form PTO/SB/08: Substitute for form 1449A/PTO			<b>Complete if Known</b>	
<b>INFORMATION DISCLOSURE STATEMENT BY APPLICANT</b>  (Use as many sheets as necessary)			<i>Application Number</i>	10/101,863
			<i>Filing Date</i>	March 16, 2002
			<i>First Named Inventor</i>	ZHANG, Hongmei
			<i>Art Unit</i>	2823
			<i>Examiner Name</i>	ESTRADA, Michelle
			<i>Attorney Docket Number</i>	9140.0016-00
Sheet	4	of	9	

NON PATENT LITERATURE DOCUMENTS			
Examiner Initials	Cite No. <sup>1</sup>	Include name of the author (in CAPITAL LETTERS), title of the article (when appropriate), title of the item (book, magazine, journal, serial, symposium, catalog, etc.), date, page(s), volume-issue number(s), publisher, city and/or country where published.	Translation <sup>6</sup>
		AFFINITO et al., "PML/oxide/PML Barrier Layer Performance Differences Arising from Use of UV or Electron Beam Polymerization of the PML Layers," <i>Thin Solid Films</i> Vol. 308-309, pp. 19-25 (1997)	
		AFFINITO et al., "Polymer-Oxide Transparent Barrier Layers," Society of Vacuum Coaters, 39th Ann. Technical Conference Proceedings, May 5-10, 1996, Philadelphia, PA, pp. 392-397 (1996).	
		ALDER, T. et al., "High-Efficiency Fiber-to-Chip Coupling Using Low-Loss Tapered Single-Mode Fiber," <i>IEEE Photonics Technology Letters</i> , 12(8):1016-1018 (2000).	
		ALMEIDA, Vilson R. et al., "Nanotaper for compact mode conversion," <i>Optics Letters</i> , 28(15):1302-1304 (2003).	
		ASGHARI et al., "ASOC--A Manufacturing Integrated Optics Technology," Part of the SPIE Conference on Integrated Optics Devices III, vol. 3620, pp. 252-262 (Jan. 1999).	
		BARBIER et al, "Amplifying Four-Wavelength Combiner, Based on Erbium/Etterbium-Doped Waveguide Amplifiers and Integrated Splitters", <i>IEEE PHOTONICS TECHNOLOGY LETTTERS</i> , Vol.9, pp 315-317, 1997, 4 pages	
		BEACH R.J., "Theory and optimization of lens ducts," <i>Applied Optics</i> , 35:12:2005-15 (1996)	
		BESTWICK, T., "ASOC silicon integrated optics technology," Part of the SPIE Conferences on Photonics Packaging and Integration, SPIE vol. 3631, pp. 182-190 (Jan. 1999).	
		BORSELLA et al., "Structural incorporation of silver insoda-lime glass by the ion-exchange process: a photoluminescence spectroscopy study", <i>Applied Physics A</i> 71, pp. 125-132 (2000)	
		CAMPBELL et al., "Titanium dioxide (TiO <sub>2</sub> )-based gate insulators," <i>IBM J. Res. Develop.</i> 43(3), 383-391, (May 1999).	
		CHANG, C.Y. (edited by), "ULSI Technology," The McGraw-Hill Companies, Inc., New York, 1996, Chapter 4, pp. 169-170, 226-231 (1996)..	
		CHEN et al. "Development of Supported Bifunctional Electrocatalysts for Unitized Regenerative Fuel Cells," <i>Journal of the Electrochemical Society</i> , 149(8), A1092-99, (2002).	
		CHOI et al., "Er-Al-codoped silicate planar light waveguide-type amplifier fabricated by radio-frequency sputtering," <i>Optics Letters</i> , vol. 25, No. 4, pp. 263-265 (Feb. 15, 2000).	
		COOKSEY et al. "Predicting Permeability & Transmission Rate for Multilayer Materials," <i>Foodtechnology</i> , Vol. 53, No. 9, pp. 60-63 (September 1999).	
		Crowder, et al., "Low-Temperature Single-Crystal Si TFT's Fabricated on Si Films Processed via Sequential Lateral Solidification," <i>IEEE</i> , vol. 19, no. 8 (August 1998), pages 306-308.	

Examiner Signature	Date Considered
--------------------	-----------------

EXAMINER: Initial if reference considered, whether or not citation is in conformance with MPEP 609. Draw line through citation if not in conformance and not considered. Include copy of this form with next communication to applicant.

IDS Form PTO/SB/08: Substitute for form 1449A/PTO				<b>Complete if Known</b>	
<b>INFORMATION DISCLOSURE STATEMENT BY APPLICANT</b>  (Use as many sheets as necessary)				<i>Application Number</i>	10/101,863
				<i>Filing Date</i>	March 16, 2002
				<i>First Named Inventor</i>	ZHANG, Hongmei
				<i>Art Unit</i>	2823
				<i>Examiner Name</i>	ESTRADA, Michelle
Sheet	5	of	9	<i>Attorney Docket Number</i>	9140.0016-00

NON PATENT LITERATURE DOCUMENTS			
		DELAVAUX et al., "Integrated optics erbium ytterbium amplifier system in 10 Gb/s fiber transmission experiment", 22nd European Conference on Optical Communication - ECOC' 96, Oslo, 4 pages (1996).	
		Distributed Energy Resources: Fuel Cells, Projects, <a href="http://www.eere.energy.gov/der/fuel_cells/projects.html">http://www.eere.energy.gov/der/fuel_cells/projects.html</a> (2003).	
		DuPont Teijin Films, Mylar 200 SBL 300, Product Information (2000).	
		Electrometals Technologies Limited, Financial Report for the year 2002, Corporate Directory, Chairman's Review, Review of Operations (2002).	
		E-Tek website: FAQ, Inside E-Tek, E-Tek News, Products; <a href="http://www.etek-inc.com/">http://www.etek-inc.com/</a> (2003).	
		FLYTZANIS et al, "nonlinear Optics in Composite Materials," E. Wolf, Progress in Optics XXIX (c) Elsevier Science Publishers B.V., pp. 323-425 (1991).	
		FRAZAO et al., "EDFA Gain Flattening Using Long-Period Fibre Gratings Based on the Electric Arc Technique," (date unknown).	
		GARCIA, C. "Size Dependence of Lifetime and Absorption Cross Section of Si Nanocrystals Embedded in SiO <sub>2</sub> ," Appl. Phys. Lett., Vol. 82, No. 10, pp. 1595-7 (March 2003).	
		GOOSSENS et al., "Sensitization of TiO <sub>2</sub> with p-type semiconductor polymers," Delft Interfaculty Research Center, Delft University of Technology Laboratory of Inorganic Chemistry, The Netherlands (1998).	
		Greene et al., "Morphological and electrical properties of rf sputtered Y2O3-doped ZrO2 thin films," J. Vac. Sci. Technol., vol. 13, no. 1 (Jan/Feb 1976), pages 72-75.	
		HAN, Hak-Seung et al. "Optical Gain at 1.54 μm in Erbium-Doped Silicon Nanocluster Sensitized Waveguide," <i>Appl. Phys. Lett.</i> , Vol. 79, No. 27, pp. 4568-70 (December 2001).	
		HAYAKAWA et al., "Enhanced fluorescence from Eu <sup>3+</sup> owing to surface plasma oscillation of silver particles in glass", <i>Journal of Non-Crystalline Solids</i> , Vol. 259, pp. 16-22 (1999).	
		HAYAKAWA et al, "Field enhancement effect of small Ag particles on the fluorescence from Eu <sup>3+</sup> -doped SiO <sub>2</sub> glass", <i>Appl. Phys. Lett.</i> , Vol. 74, No 11, pp. 1513-1515 (March 1999).	
		HAYFIELD, P.C.S., "Development of a New Material-Monolithic Ti4O7 Ebonix Ceramic," Royal Society Chemistry," (2002).	
		HEHLEN et al. "Spectroscopic Properties of Er <sup>3+</sup> - and Yb <sup>3+</sup> -doped Soda-Lime Silicate and Aluminosilicate Glasses," <i>Physical Review B</i> , Vol. 56, No. 15, pp. 9302-9318 (October 1997).	
		HEHLEN et al. "Uniform Upconversion in High-Concentration Er <sup>3+</sup> -doped Soda Lime Silicate and Aluminosilicate Glasses," <i>Optics Letters</i> , Vol. 22, No. 11, pp. 772-774 (June 1997).	
		HORST et al., "Compact, Tunable Optical Devices in Silicon-Oxynitride Wave Guide Technology," IBM Research Division, 3 pages (1999).	

Examiner Signature		Date Considered	
--------------------	--	-----------------	--

EXAMINER: Initial if reference considered, whether or not citation is in conformance with MPEP 609. Draw line through citation if not in conformance and not considered. Include copy of this form with next communication to applicant.

IDS Form PTO/SB/08: Substitute for form 1449A/PTO			<b>Complete if Known</b>	
<b>INFORMATION DISCLOSURE STATEMENT BY APPLICANT</b>  <i>(Use as many sheets as necessary)</i>			<i>Application Number</i>	10/101,863
			<i>Filing Date</i>	March 16, 2002
			<i>First Named Inventor</i>	ZHANG, Hongmei
			<i>Art Unit</i>	2823
			<i>Examiner Name</i>	ESTRADA, Michelle
			<i>Attorney Docket Number</i>	9140.0016-00
Sheet	6	of	9	

NON PATENT LITERATURE DOCUMENTS			
		HUBNER, J. and Guldberg-Kjaer, S., "Planar Er-and Yb-Doped Amplifiers and Lasers," COM Technical University of Denmark, 10.sup.th European Conf. On Integrated Optics, Session WeB2, pp. 71-74 (2001).	
		Hwang, Man-Soo et al., "The effect of pulsed magnetron sputtering on the properties of indium tin oxide thin films," Elsevier Science B.V., P. 29-33, (2003).	
		Im, et al. "Controlled Super-lateral Growth of Si Films for Microstructural Manipulation and Optimization," Materials Science Program (1998), pages. 603-617.	
		Im, et al., "Crystalline Si Films for Integrated Active-Matrix LiquidCrystal Displays," MrS Bulletin (March 1996), pages. 39-48.	
		Im, et al., "Single-crystal Si films for thin-film transistor devices," American Institute of Physics (1997), pages. 3434-3436.	
		ITOH, M. et al., "Large reduction of singlemode-fibre coupling loss in 1.5% delta planar lightwave circuits using spot-size converters," <u>Electronics Letters</u> , 38(2):72-74 (2002).	
		JACKSON et al. "An Accurate Compact EDFA Model," Dept. of Electrical and Computer Engineering, University of BC (date unknown).	
		JANSSEN et al. "Photoinduced electron transfer from conjugated polymers onto nanocrystalline TiO <sub>2</sub> ," Eindhoven University of Technology, The Netherlands (date unknown).	
		JOHNSON, J.E. et al., "Monolithically Integrated Semiconductor Optical Amplifier and Electroabsorption Modulator with Dual-Waveguide Spot-Size Converter Input," <u>IEEE Journal of Selected Topics in Quantum Electronics</u> , 6(1):19-25, (2000).	
		JONSSON L.B. et al. "Frequency response in pulsed DC reactive sputtering processes," <u>Thin Solid Films</u> , Vol. 365, pp. 43-48 (2000).	
		KATO et al., "Recent progress on PLC hybrid integration," Part of the SPIE Conference on Optoelectric Integrated Circuits III, SPIE. vol. 3631, pp. 28-36 (Jan. 1999).	
		KATO, Kuniharu et al., "PLC Hybrid Integration Technology and Its Application to Photonic Components," <u>IEEE Journal of Selected Topics in Quantum Electronics</u> , 6(1):4-13 (2000).	
		KIK, P.G. et al. "Gain Limiting Processes in Er-doped Si Nanocrystal Waveguides in SiO <sub>2</sub> ," <u>J. Appl. Phys.</u> , Vol. 91, No. 1, pp. 534-536 (January 1, 2002).	
		KIM et al. "Frequency-dependent pulsed direct current magnetron sputtering of titanium oxide films," <u>J. Vac. Sci. Technol. A</u> 19(2); 429-434 (March 2001).	
		KIM et al. "Mixture Behaviour and Microwave Dielectric Properties in the Low-fired TiO <sub>2</sub> -CuO System," <u>Jpn. J. Appl. Phys.</u> , 39, 2696-2700, (2000).	
		LADOUCEUR, F. et al., "8.8 Evaluation of Results", <u>Silica-based Buried Channel Waveguides and Devices</u> , Chapman & Hall, London, pp. 98-99 (1996).	
		LADOUCEUR, F. et al., "Effect of side wall roughness in buried channel waveguides," <u>IEEE Proc.</u> , vol. 141, pp. 242-248 (Aug. 1994).	
		LAMB, William B., "Designing Nonfoil Containing Skins for VIP Applications," DuPont VIA Symposium Presentation, (1999).	

Examiner Signature		Date Considered	
--------------------	--	-----------------	--

EXAMINER: Initial if reference considered, whether or not citation is in conformance with MPEP 609. Draw line through citation if not in conformance and not considered. Include copy of this form with next communication to applicant.

IDS Form PTO/SB/08: Substitute for form 1449A/PTO			<b>Complete if Known</b>	
<b>INFORMATION DISCLOSURE STATEMENT BY APPLICANT</b>  <i>(Use as many sheets as necessary)</i>			<i>Application Number</i>	10/101,863
			<i>Filing Date</i>	March 16, 2002
			<i>First Named Inventor</i>	ZHANG, Hongmei
			<i>Art Unit</i>	2823
			<i>Examiner Name</i>	ESTRADA, Michelle
			<i>Attorney Docket Number</i>	9140.0016-00
Sheet	7	of	9	

NON PATENT LITERATURE DOCUMENTS			
		LAMB, William et al. "Designing Non-Foil Containing Skins for Vacuum Insulation Panel (VIP) Applications," <i>Vuoto</i> , Vol. XXVIII, No. 1-2 - Gennaio-Giugno 1999, pp. 55-58 (1999).	
		LANGE et al, "High Gain Ultra-Short Length Phosphate glass Erbium-Doped Fiber Amplifier Material", <i>OSA Optical Fiber Communications (OFC)</i> , 3 pages (2002).	
		LAPORTA et al, "Diode-pumped cw bulk Er: Yb: glass laser", <i>1952 Optics Letters/Vol. 16, No. 24/Dec. 15, 6 pages (1991)</i> .	
		LAURENT-LUND, C. et al., "PECVD Grown Multiple Core Planar Waveguides with Extremely Low Interface Reflections and Losses," <i>IEEE Photonics Technology Letters</i> , Vol. 10, No. 10, pp. 1431-1433 (Oct. 1998).	
		LEE et al., "Effect of size and roughness on light transmission in a S/SiO <sub>2</sub> waveguide: Experiments and model," Department of Materials Science and Engineering, Massachusetts Institute of Technology, (Jul. 12, 2000).	
		LEE et al. "Effects of interfacial layer growth on the electrical characteristics of thin titanium oxide films on silicon," <i>Applied Physics Letters</i> , 74(21), 3143-3145, (May 1999).	
		LOVE, J.D. et al., "Quantifying Loss Minimisation in Single-Mode Fibre Tapers," <i>Electronics Letters</i> , 22(17):912-914, (1986).	
		MARDARE et al. "On the structure of Titanium Oxide Thin Films," <i>Analele Stiintifice Ale Universitatii AL. I. Cuza IASI</i> , Vol. XLV-XLVI, 201-208 (1999).	
		MARQUES, P.V.S. et al., "Planar Silica-on-Silicon Waveguide Lasers Based in Two Layer Core Devices," 10.sup.th European Conference on Integrated Optics, Session WeB2, pp. 79-82 (2001).	
		MEIJERINK et al, LUMINESCENCE OF AG <sup>+</sup> IN CRYSTALLINE AND GLASSY SrB <sub>4</sub> O <sub>7</sub> , <i>Journal of Physics and Chemistry of Solids</i> , Vol. 54, No. 8, pp. 901-906, (1993).	
		MESNAOUI et al, "Spectroscopic properties of AG <sup>+</sup> ions in phospage glasses of NaPO <sub>3</sub> .AgPO <sub>3</sub> system", <i>EUROPEAN JOURNAL OF SOLID STATE AND INORGANIC CHEMISTRY</i> , Vol. 29, pages 1001-1013, 14 pages (1992).	
		MITOMI, O. et al., "Design of a Single-Mode Tapered Waveguide for Low-Loss Chip-to-Fiber Coupling.," <i>IEEE Journal of Quantum Electronics</i> , 30(8):1787-1793, (1994).	
		MIZUNO et al. "Temperature dependence of oxide decomposition on titanium surfaces in UHV," submitted to <i>Journal of Vacuum Science and Technology</i> , (October 28, 2001).	
		OHKUBO et al., "Polarization-Insensitive Arrayed-Waveguide Grating Using Pure SiO <sub>2</sub> Cladding," <i>Fifth Optoelectronics and Communication Conference (OECC 2000) Technical Digest</i> , 2 pages (Jul. 2000).	
		OHMI et al., "Rare earth metal oxides for high-K gate insulator," Tokyo Institute of Technology, (date unknown).	
		OHTSUKI et al., "Gain Characteristics of a high concentration Er <sup>3+</sup> -doped phosphate glass waveguide", <i>J. Appl. Phys.</i> 78(6), pp. 3617-3621 (1995).	
		ONO et al., "Design of a Low-loss Y-branch Optical Waveguide," <i>Fifth Optoelectronic and Communications Conference (OECC 2000) Technical Digest</i> , 2 pages (Jul. 2000).	

Examiner Signature		Date Considered	
--------------------	--	-----------------	--

EXAMINER: Initial if reference considered, whether or not citation is in conformance with MPEP 609. Draw line through citation if not in conformance and not considered. Include copy of this form with next communication to applicant.

IDS Form PTO/SB/08: Substitute for form 1449A/PTO			<b>Complete if Known</b>	
<b>INFORMATION DISCLOSURE STATEMENT BY APPLICANT</b>  <i>(Use as many sheets as necessary)</i>			<i>Application Number</i>	10/101,863
			<i>Filing Date</i>	March 16, 2002
			<i>First Named Inventor</i>	ZHANG, Hongmei
			<i>Art Unit</i>	2823
			<i>Examiner Name</i>	ESTRADA, Michelle
			<i>Attorney Docket Number</i>	9140.0016-00
Sheet	8	of	9	

NON PATENT LITERATURE DOCUMENTS		
		PADMINI et al. "Realization of High Tunability Barium Strontium Titanate Thin Films by RF Magnetron Sputtering," College of Engineering, University of California, Santa Barbara. (date unknown).
		PETERS et al., "Formation mechanism of silver nanocrystals made by ion irradiation of Na <sup>+</sup> --Ag <sup>+</sup> ion-exchanged sodalime silicate glass", Nuclear Instruments and Methods in Physics Research B 168, pp. 237-244 (2000).
		RAJARAJAN, M. et al., "Numerical Study of Spot-Size Expanders for an Efficient OEIC to SMF Coupling," <i>IEEE Photonics Technology Letters</i> , 10(8):1082-1084, (1998).
		RAMASWAMY et al., "Ion-Exchanged Glass Waveguides: A Review", <i>Journal of Lightwave Technology</i> , Vol. 6, No. 6, pp. 984-1001 (1988)
		Sanyo Vacuum Industries Co., Ltd. Products Info, TiO <sub>2</sub> . (2003). <a href="http://www.sanyovac.co.jp/Englishweb/products/ETiO2.htm">http://www.sanyovac.co.jp/Englishweb/products/ETiO2.htm</a>
		SCHERMER, R. et al., "Investigation of Mesa Dielectric Waveguides," Proceedings of the OSA Integrated Photonics Research Topical Meeting and Exhibit, Paper No. IWB3 (Jun 2001).
		Second International Symposium of Polymer Surface Modification: Relevance to Adhesion, Preliminary Program (1999).
		Seventh International Conference on TiO <sub>2</sub> Photocatalysis: Fundamentals & Applications, Toronto, Ontario, Canada, Final Program (November 17-21, 2002)
		SEWELL, P. et al., "Rib Waveguide Spot-Size Transformers: Modal Properties," <i>Journal of Lightwave Technology</i> , 17(5):848-856, (1999).
		SLOOFF et al, "Optical properties of Erbium-doped organic polydentate cage complexes", <i>J. Appl. Phys.</i> 83, pp. 497-503 (Jan. 1998).
		SMITH, R.E., "Reduced Coupling Loss Using a Tapered-Rib Adiabatic-Following Fiber Coupler," <i>IEEE Photonics Technology Letters</i> , 8(8):1052-1054 (1996).
		STROHHOFER, et al. "Energy transfer to Er <sup>3+</sup> in Ag ion-exchanged glass", FOM Institute for Atomic and Molecular Physics, 10 pages (date unknown).
		SUGIYAMA et al., "Gas Permeation Through the Pinholes of Plastic Film Laminated with Aluminium Foil," <i>Vuoto</i> , Vol. XXVIII, N. 1-2 - Gennaio-Guigno (1999).
		TERVONEN, A., "Challenges and opportunities for integrated optics in optical networks," Part of the SPIE Conference in Integrated Optics Devices III, SPIE vol. 3620, pp. 2-11 (Jan. 1999).
		TREICHEL et al., "The influence of pulsed magnetron sputtering on topography and crystallinity of TiO <sub>2</sub> films on glass," <i>Space and Coatings Technology</i> , Vol. 123, pp. 268-272 (2000).
		Tukamoto, H. et al., "Electronic Conductivity of LiCoO <sub>s</sub> and Its Enhancement by Magnesium Doping," <i>J. Electrochem. Soc.</i> , vol. 44, no. 9, pages 3164-3168 (September 1997).
		VILJANEN et al, "Planar Optical Coupling Elements for Multimode Fibers with Two-Step Ion Migration Process", <i>Applied Physics</i> , 24, No. 1, pp. 61-63 (January 1981).
		VILLEGAS et al, "Optical spectroscopy of a soda lime glass exchanged with silver", <i>Physics and Chemistry of Glasses</i> 37(6), pp. 248-253 (1996).

Examiner Signature		Date Considered	
--------------------	--	-----------------	--

EXAMINER: Initial if reference considered, whether or not citation is in conformance with MPEP 609. Draw line through citation if not in conformance and not considered. Include copy of this form with next communication to applicant.

IDS Form PTO/SB/08: Substitute for form 1449A/PTO			<b>Complete if Known</b>	
<b>INFORMATION DISCLOSURE STATEMENT BY APPLICANT</b>  <i>(Use as many sheets as necessary)</i>			<i>Application Number</i>	10/101,863
			<i>Filing Date</i>	March 16, 2002
			<i>First Named Inventor</i>	ZHANG, Hongmei
			<i>Art Unit</i>	2823
			<i>Examiner Name</i>	ESTRADA, Michelle
			<i>Attorney Docket Number</i>	9140.0016-00
Sheet	9	of	9	

NON PATENT LITERATURE DOCUMENTS		
		VON ROTTKAY et al. "Influence of stoichiometry on electrochromic cerium-titanium oxide compounds," Lawrence Berkeley National Laboratory, UC Berkeley, CA, (date unknown).
		WILKES, Kenneth T. "Gas Permeation Through Vacuum Barrier Films and its Effect on VIP Thermal Performance," Vacuum Insulation Panel Symp., Baltimore, Maryland, (May 3, 1999).
		YANAGAWA, H. et al., "Index-and-Dimensional Taper and Its Application to Photonic Devices," Journal of Lightwave Technology, 10(5):587-591 (1992).
		Response to Office Action filed on March 14, 2005 in U.S. Serial No. 10/291,179 (Attorney Docket No. 09140-0001-00).
		Office Action issued on June 15, 2005 in U.S. Serial No. 10/291,179 (Attorney Docket No. 09140-0001-00).
		Response to Office Action filed on September 3, 2002 in U.S. Patent No. 6,533,907 (Attorney Docket No. 09140-0004-00).
		Response to Office Action filed on August 10, 2004 in U.S. Serial No. 09/903,081 (Attorney Docket No. 09140-0014-00).
		Office Action issued on February 12, 2004 in U.S. Serial No. 09/903,081 (Attorney Docket No. 09140-0014-00).
		Amendment/RCE filed on March 10, 2005 in U.S. Serial No. 09/903,081 (Attorney Docket No. 09140-0014-00).
		Office Action issued on March 17, 2005 in U.S. Serial No. 09/903,081 (Attorney Docket No. 09140-0014-00).
		Response to Office Action filed on June 17, 2005 in U.S. Serial No. 09/903,081 (Attorney Docket No. 09140-0014-00).
		Office Action issued on July 8, 2005 in U.S. Serial No. 09/903,081 (Attorney Docket No. 09140-0014-00).
		Office Action issued on May 14, 2003 in U.S. Serial No. 10/101,492 (Attorney Docket No. 09140-0015-00).
		Response to Office Action filed on August 14, 2003 in U.S. Serial No. 10/101,492 (Attorney Docket No. 09140-0015-00).
		Response to Office Action filed on March 3, 2004 in U.S. Serial No. 10/101,492 (Attorney Docket No. 09140-0015-00).
		Response to Office Action filed on February 23, 2004 in U.S. Serial No. 10/101,341 (Attorney Docket No. 09140-0017-00).
		Response to Office Action filed on December 08, 2004 in U.S. Serial No. 10/101,341 (Attorney Docket No. 09140-0017-00).
		Office Action issued on March 14, 2005 in U.S. Serial No. 10/789,953 (Attorney Docket No. 09140-0030-00).
		Office Action issued March 24, 2005 in U.S. Application No. 10/851,542 (Attorney Docket No. 09140.0033-00).

Examiner Signature		Date Considered	
--------------------	--	-----------------	--

EXAMINER: Initial if reference considered, whether or not citation is in conformance with MPEP 609. Draw line through citation if not in conformance and not considered. Include copy of this form with next communication to applicant.



Europäisches Patentamt  
 European Patent Office  
 Office européen des brevets



(11) EP 1 189 080 A2

(12) EUROPEAN PATENT APPLICATION

(43) Date of publication:  
 20.03.2002 Bulletin 2002/12

(51) Int Cl.7: G02B 6/12

(21) Application number: 01307867.0

(22) Date of filing: 14.09.2001

(84) Designated Contracting States:  
 AT BE CH CY DE DK ES FI FR GB GR IE IT LI LU  
 MC NL PT SE TR  
 Designated Extension States:  
 AL LT LV MK RO SI

(72) Inventor: Shmulovich, Joseph  
 Murray Hill, NJ 07974 (US)

(74) Representative: Williams, Celli  
 Stevens Hewlett & Perkins  
 Halton House  
 20/23 Holborn  
 London EC1N 2JD (GB)

(30) Priority: 15.09.2000 US 663013

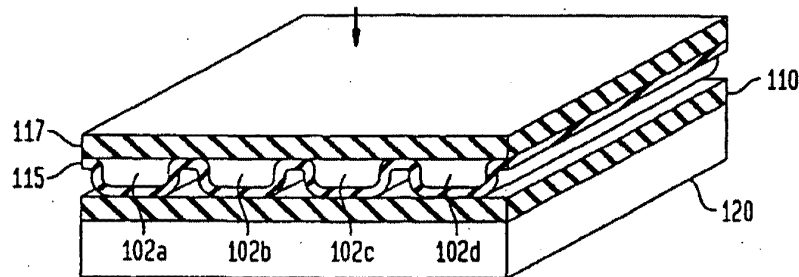
(71) Applicant: Agere Systems Optoelectronics  
 Guardian Corporation  
 Orlando, Florida 32819-8698 (US)

(54) Method for making a planar optical waveguide

(57) The present invention is a method for making planar waveguides. The method comprises the steps of providing a workpiece comprising a layer of material suitable for the waveguide strip; patterning the layer so that the workpiece comprises a base portion and the at least one protruding portion; forming a cladding layer on the protruding portion; and attaching the cladding layer

to a substrate. Depending on the composition of the workpiece, the process may further require removing the base portion to expose the bottom surface of the protruding portion. With this method, a planar waveguide or a planar waveguide amplifier may be fabricated having thickness dimensions greater than 5  $\mu\text{m}$ , or more preferably, in the range of 10-20  $\mu\text{m}$ .

FIG. 2E



EP 1 189 080 A2

### Description

[0001] The present invention relates to a method for making planar waveguides having relatively large thickness dimensions. The invention is useful in fabricating planar waveguide arrays and planar waveguide amplifiers for communications systems.

[0002] Optical communications systems can transmit optical signals over long distances at high speeds. An optical signal is transmitted from a light source to a waveguide and ultimately to a detector. Waveguide structures such as optical fibers transmit the light signals. Basically, a waveguide structure comprises an inner core region fabricated from a material having a certain index of refraction, and an outer cladding region contiguous the core comprised of a material having a lower index of refraction. A light beam propagated along the core will be guided along the length of the waveguide by total internal reflection.

[0003] Planar waveguides are flat waveguide structures that guide light in essentially the same way as optical fibers. A planar waveguide structure comprises a higher index core strip of material (the "waveguide strip") embedded in a lower index substrate.

[0004] Optical communication systems typically include a variety of devices (e.g., light sources, photodetectors, switches, optical fibers, amplifiers, and filters). Amplifiers and filters may be used to facilitate the propagation light pulses along the waveguide.

[0005] The connections between the various system components inherently produce loss in optical communication systems. For example, in planar waveguide amplifiers it would be desirable to couple planar waveguides with a multimode signal collection fiber. However, applying conventional processing, planar waveguide amplifiers typically cannot be made with cores that are more than about 5  $\mu\text{m}$  thick, and conventional sputtered films have a thickness of about 2-3  $\mu\text{m}$ . On the other hand, a multimode signal collection fiber has a core that is typically more than 50  $\mu\text{m}$  in diameter. This mismatch in vertical dimension makes it very difficult to efficiently couple light from a multimode signal collection fiber to a planar waveguide. Losses can amount to up to 17 dB or in some cases up to ~ 97 to 98 percent of the transmitted light.

[0006] Many other factors also contribute to losses in waveguide connections. Such factors include overlap of fiber cores, misalignment of the fiber axes, fiber spacing, reflection at fiber ends, and the numerical aperture (NA) mismatch. If a fiber receiving light has a smaller NA than a fiber delivering the light, some light will enter the receiving fiber in modes that are not confined to the core and will leak out of the fiber. The loss can be quantified by the formula: Loss (dB) =  $10 \log_{10} (NA_2/NA_1)^2$ . Thus, significant losses can occur if fibers are mismatched and signals are traveling from a large core into a smaller core.

[0007] With the increasing demand for efficient, large-

scale manufacturing of hybrid integrated opto-electronic devices, there is a need to more efficiently couple various waveguide devices together while minimizing losses.

[0008] The present invention is a method for making planar waveguides. The method comprises the steps of providing a workpiece comprising a layer of material suitable for the waveguide strip; patterning the layer so that the workpiece comprises a base portion and the at least one protruding portion; forming a cladding layer on the protruding portion; and attaching the cladding layer to a substrate. Depending on the composition of the workpiece, the process may further require removing the base portion. With this method, a planar waveguide or a planar waveguide amplifier may be fabricated having thickness dimensions greater than 5  $\mu\text{m}$ , or more preferably, in the range of 10-20  $\mu\text{m}$ .

[0009] The advantages, nature and various additional features of the invention will appear more fully upon consideration of the illustrative embodiments now to be described in detail in connection with the accompanying drawings. In the drawings:

FIG. 1 is a block diagram showing steps of the inventive method;

FIGS. 2A-2E schematically illustrate a planar waveguide structure at various steps of the Fig. 1 process; and

FIG. 3 is a schematic illustration of part of an optical communications system using a planar waveguide structure fabricated by the process of Fig. 1.

[0010] It is to be understood that these drawings are for the purposes of illustrating the concepts of the invention and are not to scale.

[0011] Referring to the drawings, Fig. 1 is a schematic block diagram showing the steps in making a planar waveguide. As shown in Block A of Fig. 1, the first step is to provide a workpiece comprising a layer of material suitable for the waveguide strip. The workpiece can be a bulk disk of the strip material or a substrate-supported layer of the strip material. The layer, if desired, can exceed the thickness of the waveguide strip to be formed.

[0012] The next step, shown in Block B is to pattern the layer of strip material to form at least one protruding portion corresponding in dimension to a waveguide strip to be fabricated. The patterning can be conveniently effected by photolithography, masking one or more protruding strips and etching the unmasked material as by wet etching. Preferably a plurality of protruding portions are patterned to produce an array of waveguides.

[0013] Fig. 2A illustrates the result of this step on a workpiece comprising bulk disk 100 of core glass. The disk is patterned by wet-etching at selected portions so that it comprises a base portion 101 and a plurality of protruding portion, 102a, 102b, ..., 102d. This can be



achieved by etching various channels in the disk. The protruding portions have a thickness and width corresponding substantially in dimension to the waveguide strips sought to be fabricated. The disk advantageously comprises aluminosilicate glass, but other glasses, such as soda-lime glass may be used. If it is desired that the waveguide structure should be a waveguide amplifier, the waveguide strip material should be doped with a small percentage of rare earth dopants by techniques well known in the art. The preferred rare earth dopant is erbium.

[0014] Etchants for wet etching the channels may be selected from HF etchant (~ 1% HF),  $K_4Fe(CN)_6$ ,  $K_2Fe(CN)_6$ ,  $Na_2S_2O_3$ , and KOH in  $H_2O$ . Alternatively, other patterning techniques such as dry etching or microscale imprinting can be used to produce the protruding portions.

[0015] Ultimately, the protruding portions or 102a, 102b, ..., 102d, etc., will form the waveguide strips of the planar waveguide. Thus, the etching of the channels will be controlled to produce protruding portions having the desired dimensions. Protruding portions having a height (thickness) and/or width dimension of greater than 5  $\mu m$  may be formed. Preferably the channels are etched such that the protruding portions have a height  $h$  in the range of 10-20  $\mu m$  and a width  $w$  in the range of 50-100  $\mu m$ .

[0016] A third step shown in Block C of Fig. 1 is to deposit a cladding layer on the surface of the protruding portion(s). The cladding layer can be silica deposited by conventional techniques well known in the art. It is preferably deposited by the BPTEOS process.

[0017] Referring to FIG. 2B, a cladding layer 115 is shown deposited over the etched bulk glass, filling the channels. The material for this cladding layer will be selected depending on the waveguide strip material. The cladding material should have a lower index of refraction than the strip material. Silica cladding material can be used with aluminosilicate strip material. A plastic cladding may be used with a soda-lime strip material.

[0018] The patterned workpiece with the cladding layer thereon is then attached to a substrate for the planar waveguide (FIG. 1, block D). The cladding layer is attached to the waveguide substrate.

[0019] Fig. 2C shows the workpiece 100 inverted and the cladding layer is attached to the waveguide substrate 120. The substrate can be any of a wide variety of materials including glasses, ceramics and semiconductors. Preferably it is silicon. A dielectric or insulating layer 110, such as a layer of silica ( $SiO_2$ ), may be disposed on the surface of between the substrate 120. The workpiece cladding can be attached to the substrate, by molecular bonding, such as with aluminosilicate or silicon, or by other appropriate bonding agents such as ceramic bakeable pastes. At this stage, the core (protruding portions 102a, 102b, ..., 102d) may be isolated with cladding on three sides and bound to the disk 100 at the fourth side. There is much flexibility in selecting the type

of bonding agent because the core is protected from contacting the adhesive. Interstices 111a, 111b, ..., 111d, between the silica layer 110 and substrate 120 may be filled, if desired, with cladding material.

[0020] If the workpiece comprises a thin layer of strip material on a cladding material support, the waveguide is substantially complete. If the layer of strip material is thick or workpiece is a bulk disk of strip material, then the next step (Block E of Fig. 1) is to remove the base portion of the workpiece selectively leaving the protruding portions.

[0021] Referring to FIG. 2D, the base of the bulk glass disk 101 may be etched away, leaving the protruding portions 102a, 102b, ... partially surrounded by cladding layer 115 to comprise planar waveguide strips.

[0022] As a further optional final step, a top cladding layer 117 may be deposited over the exposed protruding portions 102a, 102b (FIG. 2E). If desired, the resulting structure may be diced into smaller pieces.

[0023] The method of the invention may be used to fabricate a waveguide structure or waveguide amplifier having waveguide core strips with relatively large dimensions. For example, a waveguide or waveguide amplifier may be made having cross-sectional dimensions of tens of microns, i.e., the height of the waveguide strips may be greater than 5  $\mu m$  and more preferably in the range of about 10  $\mu m$  - 20  $\mu m$  or greater. The width of the strips also may be greater than 5  $\mu m$  and more preferably in the range of about 30  $\mu m$  - 50  $\mu m$  or greater. Thus, the method allows for the making of planar waveguide structures having larger dimensions than possible with conventional methods. Such a structure is advantageous as it helps to reduce the vertical dimension mismatch between planar waveguides and optical fibers and thereby to reduce the losses that occur when such components are coupled together. The method is also advantageous as it can use wet etching which is faster than the dry etching and deposition techniques conventionally used for producing planar waveguides.

[0024] FIG. 3 shows a communications system comprising a transmitter 100, an amplifier 60 fabricated by the inventive method, and a detector 200. The amplifier 60 has larger dimensions than planar waveguides made using conventional processing. These dimensions enable more efficient coupling with optical fibers 110a, 110b. Couplers 55, 75 are used to connect the planar waveguide 60 to input 110a and output 110b fibers. Advantageously, these couplers have the configuration described in applicant's co-pending US patent application Serial No 09/663,014, entitled "Article Comprising a Multimode Optical Fiber Coupler".

[0025] More particularly, the couplers 55, 75 each comprise a plurality of fibers with claddings that are tapered from zero thickness at the first ends of the fibers to a final thickness at the second ends (or "cladded ends") of the fibers. At the first ends of the fibers (also referred to herein as the "core exposed ends"), the core is exposed i.e. there is no surrounding cladding. The ta-

pered fibers are arranged so that their core-exposed ends are bundled together. The bundle is preferably formed into a single rod such as by fusion to define bundles 51, 71, respectively, of couplers 55, 75. The bundled, fused ends are coupled to the cores of the optical fibers 110a, 110b, carrying the transmitted signal.

[0026] At the input end, a free space combiner 54 is used to combine signals from a pump input fiber 50 and signal input fiber 52 which are directed into the first fiber coupler 55, having bundle 51 at the input end. The plurality of fibers comprising the bundle 51 have claddings that are tapered outward, so that the fibers in the bundle are splayed into individual fibers 57a, 57b, ..., 57d, and coupled to an array of large dimension waveguide strips 61a, 61b, 61c, 61d of the planar waveguide amplifier 60. The second coupler 75 is connected at the output of the planar waveguide 60 with light from each of the waveguide films being directed into individual splayed fibers 77a, 77b, ..., 77d, that are tapered down into fiber bundle 71. Light from bundle 71 could be directed into output fiber 72 toward receiver 200, and/or a splitter 74 may be disposed in the output path. The receiver bundle 71 can be optimized independent of the input constraints. According to another aspect of the invention, the receiver bundle 71 is continued as a "fiber bundle transmission line" (not shown) to a remote location and/or to the detector. This approach may be advantageous in that smaller cores will produce less dispersion than larger cores, as they support fewer modes.

[0027] The cores of the optical fibers 110a, 110b, may be relatively large, e.g., greater than 50  $\mu\text{m}$ , and multimode collection fibers may be used and coupled to the planar waveguide amplifier. Yet, there is little or no loss with this configuration. The number of fibers used in the bundles, the dimensions of the fiber cores and planar waveguides, the degree of taper, the composition of the components, and other design considerations may be adjusted depending on the application as one skilled in the field would appreciate. In matching the coupler with the planar waveguides and/or multimode fiber, a matching consideration is that the cross-sectional area of the core, times the square of the numerical aperture, optimally should be the same on both sides of a juncture. In other if "A" denotes the cross-sectional core area for signal input or output and NA is the numerical aperture, then  $A \times (\text{NA})^2$  should be substantially constant throughout the system.

[0028] The invention is advantageous in that planar waveguides may be more efficiently fabricated and also, they may be made with larger dimensions to reduce the vertical dimension mismatches and allow for coupling of planar waveguides with multimode collection fibers and other large core fibers. Planar waveguide amplifiers may be more highly doped than optical fiber amplifiers. Additionally, in multimode applications, dispersion is an important factor as an increase in modes results in greater dispersion. With this invention, there is no modal noise penalty in the amplifier, beyond the modal disper-

sion in the individual waveguides, which is small, given the dimensions of the waveguides. Additionally, with the invention an increase in the input image size does not impact upon (e.g., cause or increase) a modal noise penalty. By providing low-dispersion optical amplification, the invention increases the flexibility of the system with regard to use of photodetectors. Using conventional systems, avalanche diodes are too slow for 10 Gbit/sec detection (per channel), and while PIN diodes are fast enough, they are not sufficiently sensitive. Low-dispersion optical amplification addresses these problems with conventional systems by enabling use of avalanche diodes as photodetectors.

[0029] With this invention, the amplification of individual waveguides 61a ... 61d may be manipulated to compensate for or create possible patterns in the image. Also, the planar waveguides may be structured to reduce dispersion. It is beneficial to utilize a narrower core in the planar waveguides (i.e., in the height dimension parallel to the substrate surface and transverse to the propagation direction), to support fewer modes and hence, cause less dispersion. The waveguide amplifier structure 60 may be pumped in a cladding-pumping mode from the side by one or more extended cavity laser pumps schematically illustrated at boxed region 80 (FIG. 3). This edge-pumping scheme may be helpful in increasing pumping efficiency -- the pumping efficiency of planar waveguides is typically lower than that of optical fibers. The cladding of the planar waveguide may be so shaped and dimensioned as to confine the edge-pumped radiation, e.g., it may be a ring-shaped or serpentine cladding arrangement.

[0030] It is understood that the embodiments described herein are merely exemplary and that a person skilled in the art may make variations and modifications without departing from the scope of the invention.

#### Claims

1. A method for making a planar waveguide comprising a waveguide strip on a waveguide substrate, the method comprising the steps of:

providing a workpiece comprising a layer of material suitable for use as the planar waveguide strip;  
 patterning the layer so that the workpiece comprises a base portion and at least one protruding portion, wherein the protruding portion corresponds substantially in dimension to the waveguide strip to be fabricated;  
 forming a cladding layer on the workpiece overlying the protruding portion; and  
 attaching the cladding layer to the substrate.

2. The method of claim 1 further comprising the step of removing the base portion of the workpiece after

- attaching the cladding layer to the substrate.
3. The method of claim 1 or claim 2 wherein the substrate comprises a dielectric layer and the cladding layer is attached to the dielectric layer. 5
4. The method of claim 1, 2 or 3 wherein the layer of waveguide strip material comprises aluminosilicate. 10
5. The method of claim 3 wherein the dielectric layer comprises silica.
6. The method of any preceding claim wherein the patterning step comprises wet etching. 15
7. The method of any preceding claim wherein the patterning step comprises etching portions of the layer to define at least one protruding portion having a height dimension greater than 5 $\mu$ m. 20
8. The method of claim 7 wherein the patterning step comprises etching portions of the waveguide strip layer to define at least one protruding portion having both height and width dimensions of greater than 5 $\mu$ m. 25
9. The method of claim 8 wherein the patterning comprises etching portions of the waveguide strip layer to define at least one protruding portion having both height and width dimensions greater than 10 $\mu$ m. 30
10. The method of any one of claims 2 to 9, further comprising a step of depositing a second cladding layer over the protruding portion. 35
11. A method for making a planar waveguide structure comprising the steps of:
- providing a bulk disk of a material suitable for use as the waveguide strip; 40
- etching selected portions of the disk so that the disk comprises a base portion and at least one protruding portion, wherein the protruding portion corresponds substantially in dimension to the waveguide strip; 45
- forming a first cladding layer on the top surface of the protruding portion; 50
- attaching the first cladding layer to a substrate; and
- removing the base portion of the bulk disk.
12. The method of claim 11 wherein the bulk disk comprises glass doped with a rare earth dopant. 55
13. The method of claim 11 or 12, further comprising a step of depositing a second cladding layer over the
- protruding portion.
14. An optical communications system including a planar waveguide fabricated according to any preceding claim.

FIG. 1

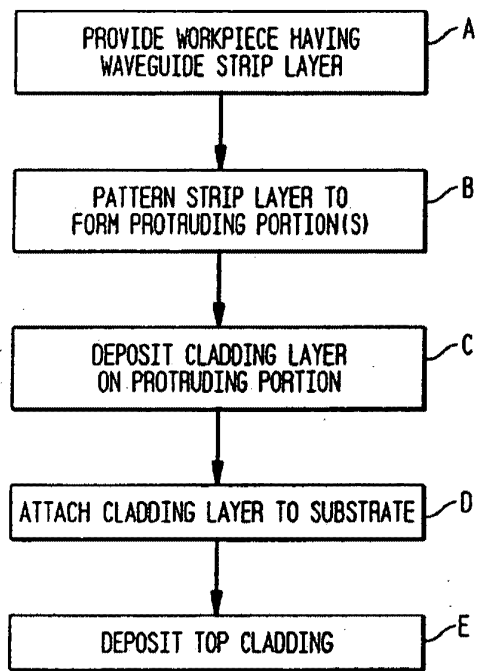


FIG. 2A

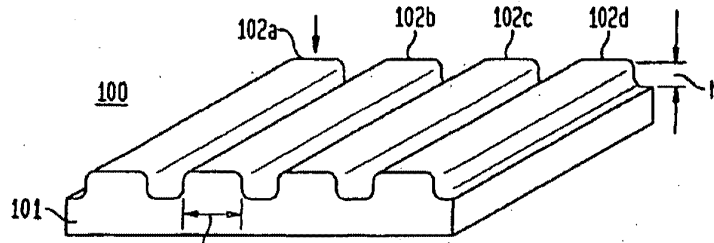


FIG. 2B

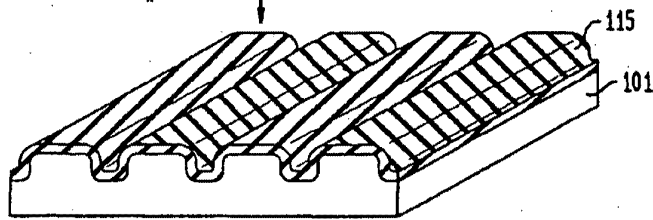


FIG. 2C

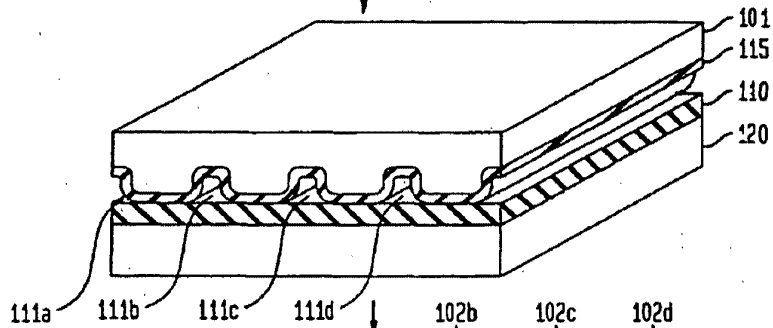


FIG. 2D

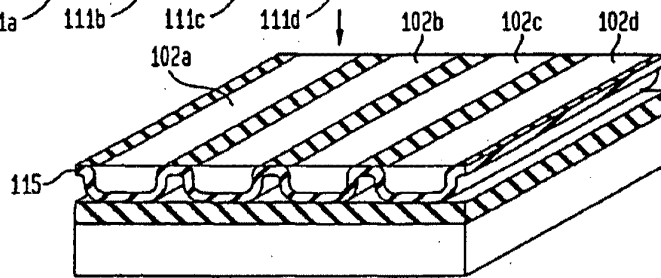


FIG. 2E

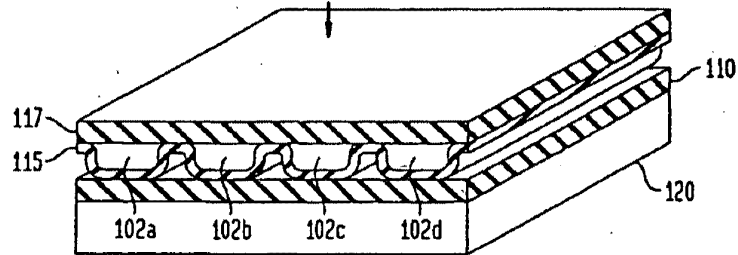
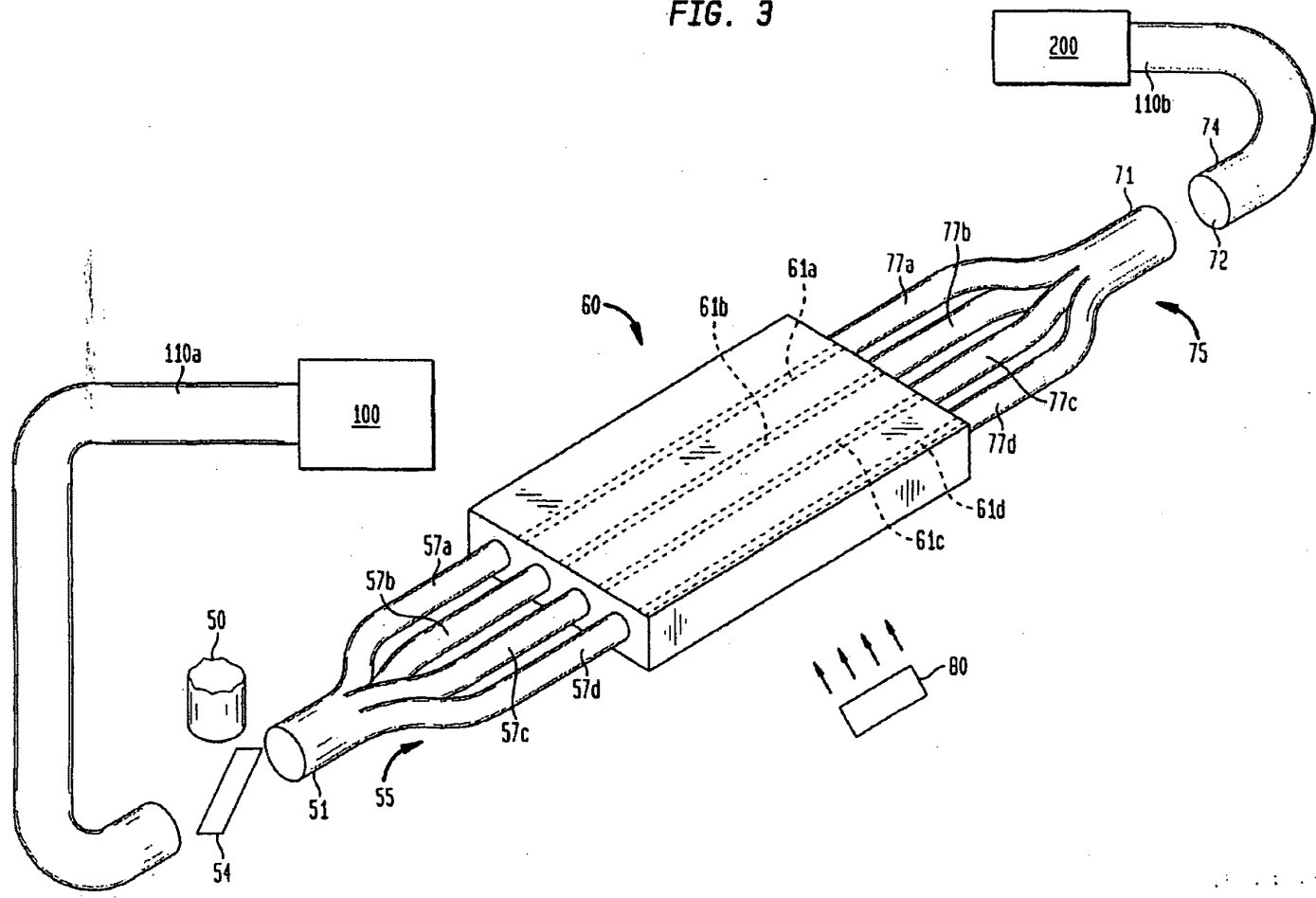


FIG. 3



EP 1 189 030 A2



Europäisches Patentamt  
European Patent Office  
Office européen des brevets



Publication number: **0 652 308 A2**

**EUROPEAN PATENT APPLICATION**

Application number: **94116188.7**      Int. Cl.<sup>6</sup>: **C30B 23/02**  
Date of filing: **13.10.94**

Priority: **14.10.93 JP 281748/93**  
**20.10.93 JP 285674/93**  
**10.12.93 JP 341281/93**  
**29.03.94 JP 58887/94**

Date of publication of application:  
**10.05.95 Bulletin 95/19**

Designated Contracting States:  
**DE FR GB NL**

Applicant: **NEURALSYSYSTEMS CORPORATION**  
**Minamisawa Bldg.,**  
**21-8, Ichigayasanai-cho,**  
**Shinjuku-ku**  
**Tokyo-to (JP)**  
Applicant: **MEGA CHIPS CORPORATION**  
**1-12-38, Esaka-cho**  
**Suita-shi,**  
**Osaka-fu (JP)**

Inventor: **Asakawa, Toshifumi**  
**6-9-25, Tsukimino**

**Yamato-shi,**  
**Kanagawa-ken (JP)**  
Inventor: **Shindo, Masahiro, c/o Mega Chips**  
**Corporation**  
**1-12-38, Esaka-cho**  
**Suita-shi,**  
**Osaka-fu (JP)**  
Inventor: **Yoshimizu, Toshikazu, c/o Mega**  
**Chips Corporation**  
**1-12-38, Esaka-cho**  
**Suita-shi,**  
**Osaka-fu (JP)**  
Inventor: **Ueyama, Sumiyoshi, c/o Mega Chips**  
**Corporation**  
**1-12-38, Esaka-cho**  
**Suita-shi,**  
**Osaka-fu (JP)**

Representative: **KUHNEN, WACKER &**  
**PARTNER**  
**Alois-Steinecker-Strasse 22**  
**D-85354 Freising (DE)**

**Method of and apparatus for forming single-crystalline thin film.**

In order to form a single-crystalline thin film on a polycrystalline substrate using plasma CVD, a downwardly directed mainly neutral Ne atom current is formed by an ECR ion generator (2). A reaction gas such as silane gas which is supplied from a reaction gas inlet pipe (13) is sprayed onto an SiO<sub>2</sub> substrate (11) by an action of the Ne atom current, so that an amorphous Si thin film is grown on the substrate (11) by a plasma CVD reaction. At the same time, a part of the Ne atom current having high directivity is directly incident upon the substrate (11), while another part thereof is incident upon the substrate (11) after its course is bent by a reflector (12). The reflector (12) is so set that all directions of the parts of the Ne atom current which are incident upon the substrate (11) are perpendicular to densest planes of single-crystalline Si. Therefore, the as-grown amorphous Si is sequentially converted to a single-crystalline Si thin film having crystal axes which are so regulated that the densest planes are oriented perpendicularly to the respective directions of incidence, by an action of the law of Bravais. Thus, a single-crystalline thin film is formed on a polycrystalline substrate.

**EP 0 652 308 A2**





## BACKGROUND OF THE INVENTION

## Field of the Invention

5 The present invention relates to a method of and an apparatus for forming a single-crystalline thin film on a substrate, i.e., an arbitrary medium, and it relates to a method of and an apparatus for forming a single-crystalline thin film, which implement selective and efficient formation of a single-crystalline thin film, and it also relates to a beam irradiator, a beam irradiating method, and a beam reflecting device for enabling efficient formation of a single-crystalline thin film or an axially oriented polycrystalline thin film on a  
10 substrate.

## Background of the Invention

Plasma chemical vapor deposition (plasma CVD) is a sort of chemical vapor deposition process (CVD),  
15 which is adapted to bring a reaction gas into a plasma state for forming active radicals and ions and to cause a chemical reaction under active environment, thereby forming a thin film of a prescribed material on a substrate under a relatively low temperature. The plasma CVD, which can form various types of films under low temperatures, has such advantages that it is possible to form an amorphous film while preventing crystallization, to employ a non-heat-resistant substrate such as a plastic substrate, and to prevent the as-  
20 formed film from a reaction with the substrate. Therefore, the application range of the plasma CVD is increasingly widened particularly in relation to semiconductor industry.

It is possible to epitaxially form a single-crystalline thin film of a prescribed material on a single-crystalline substrate by carrying out the plasma CVD under a temperature facilitating crystallization.

Generally, in order to form a single-crystalline thin film of a prescribed material on a single-crystalline  
25 substrate of the same material having the same crystal orientation, it is possible to employ an epitaxial growth process. In the epitaxial growth process, however, it is impossible to form a single-crystalline thin film on a polycrystalline substrate or an amorphous substrate. Therefore, in order to form a single-crystalline thin film on a substrate having a different crystal structure such as an amorphous substrate or a polycrystalline substrate, or a substrate of a different material, an amorphous thin film or a polycrystalline  
30 thin film is temporarily formed on the substrate so that the same is thereafter converted to a single-crystalline thin film.

In general, a polycrystalline or amorphous semiconductor thin film is single-crystallized by fusion recrystallization or lateral solid phase epitaxy.

However, such a process has the following problems: In the fusion recrystallization, the substrate is  
35 extremely thermally distorted when the thin film is prepared from a material having a high melting point, to damage physical and electrical properties of the thin film as employed. Further, an electron beam or a laser beam is employed for fusing the thin film. Therefore, it is necessary to scan spots of the electron beam or the laser beam along the overall surface of the substrate, and hence a long time and a high cost are required for recrystallization.

40 On the other hand, the lateral solid phase epitaxy is easily influenced by a method of crystallizing the material forming the substrate, while the growth rate is disadvantageously slow in this process. In order to grow a single-crystalline thin film over a distance of about 10  $\mu\text{m}$ , for example, this process requires at least 10 hours. Further, it is difficult to obtain a large crystal grain since a lattice defect is caused to stop growth of the single crystal upon progress of the growth to some extent.

45 In each process, further, it is necessary to bring a seed crystal into contact with the polycrystalline or amorphous thin film. In addition, the single crystal is grown in a direction along the major surface of the thin film, i.e., in a lateral direction, whereby the distance of growth to the crystal is so increased that various hindrances take place during the growth of the single crystal. When the substrate is made of an amorphous material such as glass, for example, the substrate has no regularity in lattice position and this irregularity  
50 influences on growth of the single crystal to disadvantageously result in growth of a polycrystalline film having large crystal grain sizes. In addition, it is difficult to selectively form a single-crystalline thin film having a prescribed crystal orientation on an arbitrary region of the substrate, due to the lateral growth.

In order to solve the aforementioned problems of the prior art, there has been made an attempt for reducing the growth distance by utilizing vertical growth of the thin film, thereby reducing the growth time.  
55 In other words, there has been tried a method of bringing a seed crystal into contact with the overall surface of a polycrystalline or amorphous thin film for making solid phase epitaxial growth in a direction perpendicular to the major surface of the thin film, i.e., in the vertical direction. As the result, however, the seed crystal was merely partially in contact with the amorphous thin film or the like and it was impossible to

form a single-crystalline thin film by the as-expected vertical solid phase epitaxial growth, since only lateral epitaxial growth was caused from the contact portion. According to this method, further, the seed crystal adhered to the as-grown single-crystalline film and it was extremely difficult to separate the former from the latter, such that the as-grown thin film was disadvantageously separated from the substrate following the  
5 seed crystal. Further, it is impossible in practice to selectively form a single-crystalline thin film having a prescribed crystal orientation on an arbitrary region of the substrate, since it is necessary to accurately arrange a seed crystal of a prescribed shape on a prescribed position.

When the substrate itself has a single-crystalline structure, it is impossible to form a single-crystalline thin film having a crystal orientation which is different from that of the substrate on the substrate by any  
10 conventional means. This also applies to a polycrystalline thin film having single crystal axes which are regulated along the same direction between crystal grains, i.e., an axially oriented polycrystalline thin film. In other words, it is difficult to form an axially oriented polycrystalline thin film which is oriented in a desired direction on an arbitrary substrate by the prior art.

## 15 SUMMARY OF THE INVENTION

The inventor has found that, when a physical seed crystal is employed in vertical growth of solid phase epitaxy, it is difficult to separate a single-crystalline thin film as grown from the seed crystal due to  
20 adhesion therebetween, and that this problem can be solved when a virtual seed crystal of a large area is employed in place of the physical seed crystal to obtain a virtual seed crystal for attaining the same effect as a seed crystal adhering to the overall surface of a single crystal in an excellent state with no physical adhesion on the surface of the single crystal in termination of the crystal growth. The present invention is based on this basic idea.

According to the present invention, a method of forming a single-crystalline thin film is adapted to form  
25 a single-crystalline thin film of a prescribed material on a substrate by previously forming an amorphous thin film or a polycrystalline thin film of the prescribed material on the substrate and irradiating the amorphous thin film or the polycrystalline thin film with beams of neutral atoms or neutral molecules of low energy levels causing no sputtering of the prescribed material under a high temperature of not more than a crystallization temperature of the prescribed material from directions which are perpendicular to a plurality  
30 of densest crystal planes, having different directions, in the single-crystalline thin film to be formed.

The thin film is at a high temperature below a crystallization temperature, whereby the single crystal which is formed in the vicinity of the surface serves as a seed crystal, so that a single crystal is grown toward a deep portion by vertical solid phase epitaxial growth to single-crystallize the overall region of the thin film along its thickness. When the thin film is at a temperature exceeding the crystallization  
35 temperature, the as-formed single crystal is converted to a polycrystalline structure which is in a thermal equilibrium state. On the other hand, no crystallization toward a deep portion progresses at a temperature which is extremely lower than the crystallization temperature. Therefore, the temperature of the thin film is adjusted to be at a high level below the crystallization temperature, such as a level immediately under the crystallization temperature.

The seed crystal, which is formed by conversion from the amorphous thin film or the polycrystalline thin  
40 film, is integral with an amorphous thin film or the polycrystalline layer remaining in the deep portion. Namely, this layer is completely in contact with the seed crystal. Therefore, vertical solid phase epitaxial growth progresses in an excellent state. Further, the seed crystal and the single crystal formed by solid epitaxial growth are made of the same material having the same crystal orientation, whereby it is not  
45 necessary to remove the seed crystal after formation of the single-crystalline thin film. Further, the single-crystalline thin film, which is formed by vertical solid phase epitaxial growth, can be efficiently obtained in a desired state in a short time.

In the method according to the present invention, it is possible to form a single-crystalline thin film on a  
50 substrate including a polycrystalline substrate or an amorphous substrate, while it is not necessary to increase the temperature of the substrate to an extremely high level. Therefore, it is possible to easily obtain a single-crystalline thin film such as a wide-use semiconductor thin film which is applied to a thin film transistor of liquid crystal display or a single-crystalline thin film which is applied to a three-dimensional LSI. While a well-known metal evaporation film is inferior in quality due to a number of vacancies such that a migration phenomenon takes place to easily cause disconnection when the same is applied to interconnec-  
55 tion of an electronic circuit, it is possible to prevent such a problem according to the present invention.

Preferably, the atomic weights of atoms forming the beams are lower than the maximum one of the atomic weights of elements forming the prescribed material.

The atomic weights of atoms forming the beams which are applied to the thin film or atoms forming molecules are lower than the maximum one of the atomic weights of elements forming the thin film, whereby most parts of the atoms forming the as-applied beams are rearwardly scattered on the surface of the thin film or in the vicinity thereof, to hardly remain in the thin film. Thus, electronic/physical properties of the thin film are hardly changed by residual of such atoms in the single-crystalline thin film.

Preferably, the beams are obtained by a single electron cyclotron resonance type ion generation source and a reflector which is arranged in a path between the ion generation source and the amorphous thin film or the polycrystalline thin film.

The beams which are applied to the thin film are obtained by a single beam source and a reflector which is arranged in a path, whereby it is possible to irradiate the substrate with the beams from a plurality of prescribed directions which are different from each other with no requirement for a plurality of beam sources. Namely, only a single beam source having a complicated structure is sufficient in the method according to the present invention, whereby a single-crystalline thin film can be formed with a simple apparatus structure. Since only one beam source is sufficient, it is possible to form the thin film under a high vacuum. Further, the beam source is formed by an electron cyclotron resonance type ion generation source, whereby the ion beams have high directivity and it is possible to obtain strong neutral beams having excellent directivity at positions beyond prescribed distances from the ion source with no means for neutralizing ions.

In the method according to the present invention, an amorphous thin film or a polycrystalline thin film which is previously formed on a substrate surface is irradiated with beams of atoms or molecules from a plurality of directions. The beams are at energy levels causing no sputtering on the material as irradiated, whereby the law of Bravais acts such that a layer close to the surface of the amorphous thin film or the polycrystalline thin film is converted to a crystal having such a crystal orientation that planes perpendicular to the directions irradiated with the beams define densest crystal planes. The plurality of beams are applied from directions perpendicular to a plurality of densest crystal planes having different directions, whereby the orientation of the as-formed crystal is set in a single one. In other words, a single-crystalline thin film having a regulated crystal orientation is formed in the vicinity of a surface of the amorphous thin film or the polycrystalline thin film.

The inventor has also found that a single-crystalline thin film can be obtained by growing a thin film and converting the same to a single-crystalline simultaneously instead of previously forming a thin film. This invention is also based on this idea.

According to the present invention, a method of forming a single-crystalline thin film forms a single-crystalline thin film of a prescribed material on a polycrystalline substrate or an amorphous substrate using plasma chemical vapor deposition by supplying a reaction gas onto the substrate under a low temperature allowing no crystallization of the prescribed material with the plasma chemical vapor deposition alone while simultaneously irradiating the substrate with beams of a low energy gas causing no sputtering of the prescribed material from directions which are perpendicular to a plurality of densest crystal planes having different directions in the single-crystalline thin film to be formed.

In the method according to the present invention, a thin film of a prescribed material is formed on a substrate by plasma chemical vapor deposition, while the substrate is irradiated with beams of a gas from a plurality of directions. The gas beams are at energy levels causing no sputtering on the material as irradiated, whereby the law of Bravais acts such that the thin film of the prescribed material as being formed is sequentially converted to a crystal in such a crystal orientation that planes perpendicular to directions of the beams define densest crystal planes. The substrate is irradiated with a plurality of gas beams from directions perpendicular to a plurality of densest crystal planes having different directions, whereby the as-formed crystal has only one orientation. In other words, a single-crystalline thin film having a regulated crystal orientation is formed.

Under a temperature facilitating crystallization of a prescribed material by plasma chemical vapor deposition alone with no beam irradiation, crystal orientations are arbitrarily directed regardless of directions of beam irradiation and cannot be regulated, while a polycrystalline film is formed. Therefore, temperature control is performed to a low level for facilitating no crystallization with plasma chemical vapor deposition alone.

In the method according to the present invention, further, conversion to a single crystal simultaneously sequentially progresses in the process of growth of the thin film by plasma chemical vapor deposition. Thus, it is possible to form a single-crystalline thin film having a large thickness under a low temperature.

Preferably, the gas is an inert gas.

The substrate is irradiated with an inert gas, whereby atoms or ions which may remain in the as-formed thin film after irradiation exert no bad influence on electronic/physical properties of the single-crystalline thin

film as impurities.

Preferably, the atomic weight of an element forming the inert gas is lower than the maximum one of the atomic weights of elements forming the prescribed material.

5 The atomic weight of an element forming the inert gas is lower than the maximum atomic weight of elements forming the prescribed material which is grown as a thin film, whereby most parts of atoms or ions of the as-applied inert gas rearwardly recoil on the surface of the thin film or in the vicinity thereof, to hardly remain in the thin film.

Preferably, the prescribed material contains an element forming a gas material which is in a gas state under ordinary temperatures, and the beams of the gas are those of the gas material.

10 The gas as applied contains elements forming the material which is grown as the thin film. Even if atoms or ions of the elements remain after irradiation, therefore, the same exert no bad influence on the as-formed single-crystalline thin film as impurities. Further, it is also possible to supply the element to the thin film only by application of the gas beams without introducing the same into the reaction gas.

15 Preferably, the reaction gas contains a reaction gas material which is formed by an impurity element to be added to the prescribed material.

The reaction gas contains an impurity element to be added to the material which is grown as the thin film, whereby it is possible to form a p-type or n-type semiconductor single-crystalline thin film in formation of a semiconductor single-crystalline thin film, for example. In other words, it is possible to form a single-crystalline thin film containing a desired impurity.

20 Preferably, a plurality of types of impurity elements are so employed that a plurality of types of reaction gas materials which are formed by respective ones of the plurality of types of impurity elements are alternately supplied onto the substrate.

A plurality of types of reaction gas materials formed by respective ones of a plurality of types of impurity elements are alternately supplied onto the substrate, whereby it is possible to form a single-crystalline thin film having a plurality of types of single-crystalline layers containing the respective ones of the plurality of types of impurities such that an n-type semiconductor single-crystalline layer is formed on a p-type semiconductor single-crystalline layer in formation of a semiconductor single-crystalline thin film, for example.

30 Preferably, the beams of the gas are obtained by a single beam source and a reflector which is arranged in a path between the beam source and the substrate.

The beams of the gas which are applied to the substrate are obtained by a single beam source and a reflector which is arranged on a path, whereby it is possible to irradiate the substrate with the gas beams from directions which are perpendicular to a plurality of densest crystal planes having different directions with no requirement for a plurality of beam sources. In other words, only a single beam source having a complicated structure may be so prepared that it is possible to form the single-crystalline thin film with a simple structure in the method according to the present invention. Since a single beam source may be sufficient, further, it is possible to form the thin film under a high vacuum.

Preferably, the beam source is an ion generation source generating an ion beam of the gas, and the reflector is a metal reflector which is substantially made of a metal.

40 The beam source has an ion generation source which generates an ion beam of the gas, and the reflector is prepared from a metal reflector which is substantially made of a metal. Therefore, the ion beam of the gas generated from the ion source is converted to a neutral beam when the same is reflected by the metal reflector. Therefore, the substrate is irradiated with parallel beams which are regulated in direction. Further, it is possible to prepare the substrate from an electrical insulating substrate.

45 Preferably, the beam source is an electron cyclotron resonance type ion generation source.

The beam source is formed by an electron cyclotron resonance type ion generation source. Therefore, the ion beam has high directivity, while it is possible to obtain a strong neutral beam in a portion which is separated beyond a prescribed distance from the ion source with no employment of means for neutralizing ions. It is possible to irradiate the substrate with parallel beams from a plurality of prescribed directions by reflecting the neutral beam by the reflector and applying the same to the substrate. Further, it is also possible to prepare the substrate from an electrical insulating substrate.

50 According to the present invention, a method of forming a single-crystalline thin film of a prescribed material comprises (a) a step of forming an amorphous or polycrystalline thin film of the prescribed material on a substrate, (b) a step of forming a masking material on the thin film, (c) a step of selectively removing the masking material, and (d) a step of irradiating the substrate with gas beams of low energy levels causing no sputtering of the prescribed material from directions which are perpendicular to a plurality of densest crystal planes having different directions in the single-crystalline thin film to be formed while utilizing the selectively removed masking material as a screen under a high temperature below the

crystallization temperature of the prescribed material.

Preferably, the steps (b) to (d) are carried out plural times while varying directions for applying the beams in the step (d), thereby selectively converting the thin film to a single crystal having a plurality of types of crystal orientations.

5 In the method according to the present invention, the amorphous or polycrystalline thin film which is previously formed on the substrate is irradiated with gas beams from a plurality of directions. These beams are at energy levels causing no sputtering on the material as irradiated, whereby the law of Bravais acts so that a layer which is in the vicinity of the surface of the as-irradiated thin film is converted to a crystal having such a crystal orientation that planes perpendicular to the directions of the beams define densest  
10 crystal planes. The plurality of gas beams are applied from directions which are perpendicular to a plurality of densest crystal planes having different directions, whereby the as-formed crystal is set in a single orientation. Namely, a single-crystalline layer having a regulated crystal orientation is formed in the vicinity of the surface of the polycrystalline thin film. Further, a masking material is formed on the thin film to be irradiated in advance of irradiation, and this masking material is selectively removed. Thus, irradiation  
15 progresses with limitation on a specific region of the substrate corresponding to the selectively removed portion of the masking material, whereby the single-crystalline layer is formed only in the vicinity of the surface portion of the thin film corresponding to the specific region.

Further, the thin film is at a high temperature below the crystallization temperature and hence the single crystal which is formed in the vicinity of its surface serves as a seed crystal to be grown toward a deep  
20 portion by vertical solid phase epitaxial growth, whereby the overall region of the as-irradiated thin film is single-crystallized along the thickness. If the thin film is at a temperature exceeding the crystallization temperature, the as-formed single crystal is converted to a polycrystalline structure which is in a thermal equilibrium state. On the other hand, no crystallization toward a deep portion progresses at a temperature which is extremely lower than the crystallization temperature. Therefore, the temperature of the thin film is  
25 adjusted to be at a high level below the crystallization temperature, such as a level immediately under the crystallization temperature, for example.

According to the inventive method, as hereinabove described, it is possible to selectively form a single-crystalline thin film having a regulated crystal orientation on an arbitrary specific region of a substrate.

In the method according to the present invention, the steps from formation of the masking material to  
30 irradiation with the gas beams are repeated while varying directions of irradiation. Therefore, it is possible to selectively form single-crystalline thin films having different crystal orientations on a plurality of arbitrary specific regions of the substrate.

According to the present invention, a method of forming a single-crystalline thin film of a prescribed material comprises (a) a step of forming an amorphous or polycrystalline thin film of the prescribed material  
35 on a substrate, (b) a step of forming a masking material on the thin film, (c) a step of selectively removing the masking material, (d) a step of etching the thin film while utilizing the selectively removed masking material as a screen, thereby selectively removing the thin film while leaving a specific region on the substrate, and (e) a step of irradiating the substrate with gas beams of low energy levels causing no sputtering of the prescribed material from directions which are perpendicular to a plurality of densest crystal  
40 planes having different directions in the single-crystalline thin film to be formed under a high temperature below the crystallization temperature of the prescribed material.

In the method according to the present invention, the amorphous or polycrystalline thin film is selectively removed while leaving a specific region on the substrate and thereafter the thin film is irradiated with gas beams under a prescribed temperature to facilitate action of the law of Bravais and vertical solid  
45 phase epitaxial growth, thereby converting the thin film to a single-crystalline thin film. Thus, it is possible to selectively form a single-crystalline thin film having a regulated crystal orientation on an arbitrary specific region of the substrate.

According to the present invention, a method of forming a single-crystalline thin film of a prescribed material comprises (a) a step of forming an amorphous or polycrystalline thin film of the prescribed material  
50 on a substrate, (b) a step of irradiating the substrate with gas beams of low energy levels causing no sputtering of the prescribed material from directions which are perpendicular to a plurality of densest crystal planes having different directions in the single-crystalline thin film to be formed under a high temperature below the crystallization temperature of the prescribed material, (c) a step of forming a masking material on the thin film after the step (b), (d) a step of selectively removing the masking material, and (e) a step of  
55 etching the thin film while utilizing the selectively removed masking material as a screen, thereby selectively removing the thin film.

In the method according to the present invention, the amorphous or polycrystalline thin film formed on the substrate is irradiated with gas beams under a prescribed temperature to facilitate action of the law of

Bravais and vertical solid phase epitaxial growth, thereby converting the thin film to a single-crystalline thin film. Thereafter the single-crystalline thin film is selectively removed while leaving a specific region on the substrate. Therefore, it is possible to selectively form a single-crystalline thin film having a regulated crystal orientation on an arbitrary specific region on the substrate.

5 According to the present invention, a method of forming a single-crystalline thin film of a prescribed material comprises (a) a step of forming an amorphous or polycrystalline thin film of the prescribed material on a substrate, (b) a step of irradiating the substrate with gas beams of low energy levels causing no sputtering of the prescribed material from directions which are perpendicular to a plurality of densest crystal planes having different directions in the single-crystalline thin film to be formed under a low temperature  
10 causing no crystallization of the prescribed material by the step (a) alone while carrying out the step (a), (c) a step of forming a masking material on the thin film after the steps (a) and (b), (d) a step of selectively removing the masking material, and (e) a step of etching the thin film while utilizing the selectively removed masking material as a screen, thereby selectively removing the thin film.

In the method according to the present invention, an amorphous or polycrystalline thin film is formed on  
15 the substrate with application of gas beams under a prescribed temperature for facilitating action of the law of Bravais, thereby converting the thin film as being formed sequentially to a single-crystalline thin film. Thereafter the single-crystalline thin film is selectively removed while leaving a specific region on the substrate. Thus, it is possible to selectively form a single-crystalline thin film having a regulated crystal orientation on an arbitrary specific region of the substrate.

20 According to the present invention, a method of forming a single-crystalline thin film of a prescribed material comprises (a) a step of forming an amorphous or polycrystalline thin film of the prescribed material on a substrate, (b) a step of irradiating the substrate with gas beams of low energy levels causing no sputtering of the prescribed material from directions which are perpendicular to a plurality of densest crystal planes having different directions in the single-crystalline thin film to be formed under a high temperature  
25 below the crystallization temperature of the prescribed material, (c) a step of forming a masking material on the thin film after the step (b), (d) a step of selectively removing the masking material, and (e) a step of irradiating the substrate with the gas beams of low energy levels causing no sputtering of the prescribed material from directions which are perpendicular to the plurality of densest crystal planes having different directions in the single-crystalline thin film to be formed and different from those in the step (b), while  
30 utilizing the selectively removed masking material as a screen.

In the method according to the present invention, the amorphous or polycrystalline thin film formed on the substrate is irradiated with gas beams under a prescribed temperature to facilitate action of the law of Bravais and vertical solid phase epitaxial growth, thereby converting the thin film to a single-crystalline thin film. Thereafter a masking material is selectively formed on this single-crystalline thin film, which in turn is  
35 again irradiated with gas beams from new directions. At this time, the masking material serves as a screen for the gas beams, whereby the single-crystalline thin film is converted to a second single-crystalline thin film having a new crystal orientation on a region where the masking material is selectively removed. Namely, it is possible to selectively form single-crystalline thin films having different crystal orientations on a plurality of arbitrary specific regions of the substrate.

40 The atomic weight of an element forming the gas is preferably lower than the maximum one of the atomic weights of elements forming the prescribed material.

The atomic weight of the element forming the gas beams which are applied onto the substrate is lower than the maximum one of the atomic weights of the elements forming the thin film as irradiated, whereby most parts of the atoms forming the applied gas are rearwardly scattered on the surface of the thin film as  
45 irradiated or in the vicinity thereof, to hardly remain in the thin film. Thus, it is possible to obtain a single-crystalline thin film having a small amount of impurities.

The atomic weight of an element forming the gas is preferably lower than the maximum one of the atomic weights of elements forming the masking material.

The atomic weight of the element forming the gas beams which are applied onto the substrate is lower  
50 than the maximum one of the atomic weights of the elements forming the masking material, whereby most parts of the atoms forming the gas as applied are rearwardly scattered on the surface of the masking material or in the vicinity thereof, to hardly penetrate into the masking material and the thin film as irradiated. Thus, it is possible to obtain a single-crystalline thin film having a small amount of impurities.

The present invention is also directed to an apparatus for forming a single-crystalline thin film.  
55 According to the present invention, an apparatus for forming a single-crystalline thin film of a prescribed material on a substrate comprises irradiation means for irradiating the substrate with gas beams of low energy levels causing no sputtering of the prescribed material from directions which are perpendicular to a plurality of densest crystal planes having different directions in the single-crystalline thin film to be formed,

and substrate moving means for making the substrate scanned with respect to the irradiation means.

Preferably, the apparatus for forming a single-crystalline thin film further comprises beam focusing means for bringing sections of the gas beams into strip shapes on the substrate.

5 In the apparatus according to the present invention, the substrate can be scanned by the substrate moving means, whereby it is possible to form a single-crystalline thin film having high homogeneity on a long substrate.

Further, the apparatus according to the present invention comprises beam focusing means for bringing sections of the gas beams into strip shapes on the substrate, whereby it is possible to efficiently form a single-crystalline thin film with higher homogeneity by scanning the substrate.

10 According to the present invention, an apparatus for forming a single-crystalline thin film of a prescribed material on a substrate comprises a single beam source for supplying a beam of a gas, a reflector for reflecting at least a part of the beam which is supplied by the beam source, thereby implementing irradiation of the substrate with the gas in a plurality of prescribed directions of incidence, and reflector driving means for varying the angle of inclination of the reflector.

15 In the apparatus according to the present invention, the gas beams to be applied to the thin film are obtained by a single beam source and a reflector which is arranged in a path, whereby it is possible to irradiate the thin film with the gas beams from a plurality of prescribed directions which are different to each other with no requirement for a plurality of beam sources. Further, this apparatus comprises reflector driving means, whereby it is possible to change and re-set directions of incidence of the beams upon the substrate.

20 Thus, it is possible to form a plurality of types of single-crystalline thin films having different crystal structures or different crystal orientations by a single apparatus.

According to the present invention, an apparatus for forming a single-crystalline thin film of a prescribed material on a substrate comprises a single beam source for supplying a beam of a gas, a plurality of reflectors, each of which reflects at least a part of the beam supplied by the beam source, thereby implementing irradiation of the substrate with the gas in a plurality of prescribed directions of incidence related to the angle of inclination of the reflector, and reflector exchange means for selecting a prescribed one from the plurality of reflectors and utilizing the same for reflecting the beam.

25 In the apparatus according to the present invention, the gas beams to be applied to the thin film are obtained by a single beam source and a reflector which is arranged in a path, whereby it is possible to irradiate the thin film with the gas beams from a plurality of prescribed directions which are different from each other with no requirement for a plurality of beam sources. Further, this apparatus comprises reflector exchange means, whereby it is possible to arbitrarily select directions of incidence of the beams upon the substrate from a plurality of reflectors to re-set the same. Thus, it is possible to form a plurality of types of single-crystalline thin films having different crystal structures or crystal orientations by a single apparatus.

30 The apparatus for forming a single-crystalline thin film preferably further comprises film forming means for forming an amorphous or polycrystalline thin film of the same material as the single-crystalline thin film on the substrate.

35 The apparatus of the present invention comprises film forming means such as chemical vapor deposition means, for example, whereby it is possible to sequentially convert the thin film as being formed to a single-crystalline thin film by forming the thin film while irradiating the same with gas beams. Thus, there is no need to facilitate vertical epitaxial growth of the thin film, whereby the single-crystalline thin film can be formed under a low temperature.

40 According to the present invention, an apparatus for forming a single-crystalline thin film of a prescribed material on a substrate comprises etching means for etching a surface of the substrate, film forming means for forming an amorphous or polycrystalline thin film of the prescribed material on the surface of the substrate, and irradiation means for irradiating the substrate with gas beams of low energy levels causing no sputtering of the prescribed material from directions which are perpendicular to a plurality of densest crystal planes having different directions in the single-crystalline thin film to be formed. Treatment chambers provided in the aforementioned means for storing the substrate communicate with each other.

45 The apparatus further comprises substrate carrying means for introducing and discharging the substrate into and from the respective treatment chambers.

50 The apparatus according to the present invention comprises etching means, film forming means and irradiation means having treatment chambers communicating with each other, whereby it is possible to start film formation by carrying out etching treatment for removing an oxide film and preventing new progress of oxidation before forming the thin film on the substrate by employing this apparatus. Further, this apparatus comprises substrate carrying means, whereby the substrate can be efficiently carried into the respective treatment chambers.

According to the present invention, an apparatus for forming a single-crystalline thin film of a prescribed material on a substrate having a single-crystalline structure comprises irradiation means for irradiating the substrate with gas beams of low energy levels causing no sputtering of the prescribed material from directions which are perpendicular to a plurality of densest crystal planes having different directions in the single-crystalline thin film to be formed, and attitude control means for controlling the attitude of the substrate for setting prescribed relations between directions of crystal axes of the substrate and directions of incidence of the beams.

The apparatus according to the tenth aspect of the present invention comprises attitude control means, whereby it is possible to set prescribed relations between the crystal axes of the single-crystalline substrate and the directions of incidence of the gas beams by employing this apparatus. Thus, it is possible to epitaxially form a new single-crystalline thin film on a single-crystalline substrate at a temperature below the crystallization temperature.

According to the present invention, an apparatus for forming a single-crystalline thin film of a prescribed material on a substrate comprises film forming means for forming an amorphous or polycrystalline thin film of the prescribed material on the substrate by supplying a reaction gas, irradiation means for irradiating the substrate with gas beams of low energy levels causing no sputtering of the prescribed material from directions which are perpendicular to a plurality of densest crystal planes having different directions in the single-crystalline thin film to be formed, and substrate rotating means for rotating the substrate.

The apparatus according to the present invention comprises substrate rotating means, whereby it is possible to facilitate formation of an amorphous or polycrystalline thin film by intermittently applying the beams while regularly supplying the reaction gas and rotating the substrate during application pauses. Thus, it is possible to form an amorphous or polycrystalline thin film having high homogeneity, whereby high homogeneity is also attained in a single-crystalline thin film which is obtained by converting the same.

According to the present invention, an apparatus for forming a single-crystalline thin film of a prescribed material on a substrate comprises film forming means for forming an amorphous or polycrystalline thin film of the prescribed material on the substrate by supplying a reaction gas, and irradiation means for irradiating the substrate with gas beams of low energy levels causing no sputtering of the prescribed material from directions which are perpendicular to a plurality of densest crystal planes having different directions in the single-crystalline thin film to be formed. The film forming means has supply system rotating means for rotating an end portion of a supply path for supplying the substrate with the reaction gas with respect to the substrate.

The apparatus according to the present invention comprises supply system rotating means, whereby it is possible to obtain a single-crystalline thin film having high homogeneity while regularly supplying the reaction gas and applying the beams with no intermittent application of the beams. Namely, it is possible to efficiently form a single-crystalline thin film having high homogeneity.

According to the present invention, an apparatus for forming a single-crystalline thin film of a prescribed material on a substrate comprises a plurality of irradiation means for irradiating the substrate with a plurality of gas beams of low energy levels causing no sputtering of the prescribed material from directions which are perpendicular to a plurality of densest crystal planes having different directions in the single-crystalline thin film to be formed respectively, and control means for independently controlling operating conditions in the plurality of irradiation means respectively.

In the apparatus according to the present invention, control means independently controls operating conditions in irradiation means such as output beam densities, for example, whereby states of a plurality of beams which are applied to the substrate are optimally controlled. Thus, it is possible to efficiently form a high-quality single-crystalline thin film.

The irradiation means preferably comprises an electron cyclotron resonance type ion source, and the gas beams are supplied by the ion source.

According to the present invention, an apparatus for forming a single-crystalline thin film of a prescribed material on a substrate comprises irradiation means for irradiating the substrate with beams of a gas supplied by an ion source at low energy levels causing no sputtering of the prescribed material from directions which are perpendicular to a plurality of densest crystal planes having different directions in the single-crystalline thin film to be formed, and bias means for applying a bias voltage across the ion source and the substrate in a direction for accelerating ions.

In the apparatus according to the present invention, bias means applies a bias voltage across the ion source and the substrate, whereby the gas beams are improved in directivity. Thus, it is possible to form a high-quality single-crystalline thin film having high homogeneity of the crystal orientation.

According to the present invention, an apparatus for forming a single-crystalline thin film of a prescribed material on a substrate comprises irradiation means for irradiating the substrate with beams of a gas



supplied by an ion source at low energy levels causing no sputtering of the prescribed material from directions which are perpendicular to a plurality of densest crystal planes having different directions in the single-crystalline thin film to be formed, with a grid which is provided in the vicinity of an ion outlet of the ion source, and grid voltage applying means for applying a voltage to the grid for controlling conditions for  
5 extracting ions from the ion source.

In the apparatus according to the present invention, grid voltage applying means optimally controls conditions for extracting ions from the ion source, whereby it is possible to efficiently form a high-quality single-crystalline thin film.

10 In the apparatus according to the present invention, the beam source is preferably an electron cyclotron resonance type ion source.

In the apparatus according to the present invention, the gas beams are supplied by an electron cyclotron resonance type ion source, whereby the ion beams are excellent in directivity while it is possible to obtain strong neutral beams having excellent directivity at positions beyond a prescribed distance from the ion source without employing means for neutralizing ions.

15 According to the present invention, a beam irradiator for irradiating a target surface of a sample with a gas beam comprises a container for storing the sample, and a beam source for irradiating the target surface of the sample which is set in a prescribed position of the container with the gas beam, and at least a surface of a portion irradiated with the beam is made of a material having threshold energy which is higher than energy of the beam in sputtering by irradiation with the beam among an inner wall of the container and  
20 a member which is stored in the container.

At least the surface of the portion irradiated with the beam is made of a material having threshold energy which is higher than energy of the beam in sputtering by the irradiation with the beam among the inner wall of the container and the member stored in the container, whereby no sputtering is caused even if the beam reaches the member. Therefore, consumption of the member by sputtering is suppressed, while  
25 contamination of the target sample with the material element forming the member is prevented.

According to the present invention, a beam irradiator for irradiating a target surface of a sample with a gas beam comprises a container for storing the sample, and a beam source for irradiating the target surface of the sample which is set in a prescribed position of the container with the gas beam, and at least a surface of a portion irradiated with the beam is made of a material having threshold energy with respect to  
30 sputtering which is higher than that in the target surface of the sample among an inner wall of the container and a member which is stored in the container.

At least the surface of the portion irradiated with the beam is made of a material having threshold energy with respect to sputtering which is higher than that in the target surface of the sample among the inner wall of the container and the member stored in the container, whereby no sputtering is caused in this  
35 member when the target surface of the sample is irradiated with the beam causing no sputtering. Therefore, consumption of the member by sputtering is suppressed under such usage, while contamination of the target sample with the material element forming the member is prevented.

According to the present invention, a beam irradiator for irradiating a target surface of a sample with a gas beam comprises a container for storing the sample, and a beam source for irradiating the target surface  
40 of the sample which is set in a prescribed position of the container with the gas beam, and at least a surface of a portion irradiated with the beam is made of a material containing an element which is larger in atomic weight than that forming the gas among an inner wall of the container and a member which is stored in the container.

At least the surface of the portion irradiated with the beam is made of a material containing an element  
45 which is larger in atomic weight than that forming the beam gas among the inner wall of the container and the member stored in the container, whereby permeation of a different element in the member is suppressed. Therefore, deterioration of the member caused by invasion of the different element is suppressed.

According to the present invention, a beam irradiator for irradiating a target surface of a sample with a gas beam comprises a container for storing the sample, and a beam source for irradiating the target surface  
50 of the sample which is set in a prescribed position of the container with the gas beam, and at least a surface of a portion irradiated with the beam is made of the same material as that forming the target surface of the sample among an inner wall of the container and a member which is stored in the container.

At least the surface of the portion irradiated with the beam is made of the same material as that forming  
55 the target surface of the sample among the inner wall of the container and the member stored in the container, whereby the target sample is not contaminated with the material element forming the member even if sputtering is caused in this member.

The member stored in the container preferably includes reflecting means which is interposed in a path of the beam for separating the beam into a plurality of components and irradiating the target surface of the sample with the plurality of components from directions which are different from each other.

5 The reflecting means is stored in the container and at least the surface of the portion irradiated with the beam is made of a material causing no sputtering, the same material as that of the target surface of the sample, or a material containing an element which is larger in atomic weight than that forming the beam gas, whereby contamination of the sample by sputtering of the reflecting means is prevented or deterioration of the reflecting means is suppressed.

10 The present invention is also directed to a beam irradiating method. According to the present invention, a beam irradiating method of irradiating a target surface of a sample with a gas beam comprises a step of setting the sample in a prescribed position of a container, and a step of irradiating the target surface of the sample which is set in the container with the gas beam, and the target surface is irradiated with the beam at energy which is lower than threshold energy of sputtering in a surface of a portion which is irradiated with the beam among an inner wall of the container and a member stored in the container.

15 The target surface is irradiated with the beam at energy which is lower than threshold energy of sputtering on the surface of the portion irradiated with the beam among the inner wall of the container and the member stored in the container, whereby no sputtering is caused even if the beam reaches the member. Therefore, consumption of the member by sputtering is suppressed, while contamination of the target sample with the material element forming the member is prevented.

20 The present invention is also directed to a method of forming single-crystalline thin film. According to the present invention, a method of forming a single-crystalline thin film of a prescribed material on a substrate comprises a step of depositing the prescribed material on the substrate under a low temperature causing no crystallization of the prescribed material and irradiating the prescribed material as deposited with a gas beam of low energy causing no sputtering of the prescribed material from one direction, thereby  
25 forming an axially oriented polycrystalline thin film of the material, and a step of irradiating the axially oriented polycrystalline thin film with gas beams of low energy causing no sputtering of the prescribed material under a high temperature below a crystallization temperature of the prescribed material from directions which are perpendicular to a plurality of densest crystal planes of different directions in the single-crystalline thin film, thereby converting the axially oriented polycrystalline thin film to a single-  
30 crystalline thin film.

The axially oriented polycrystalline thin film is previously formed on the substrate and thereafter irradiated with the beams from a plurality of directions so that the thin film is converted to a single-crystalline thin film. Therefore, even if the substrate is not uniformly irradiated with the beams from the plurality of directions due to a screen formed on the substrate, for example, at least either a single-  
35 crystalline thin film or an axially oriented polycrystalline thin film is formed on any portion on the substrate, whereby no remarkable deterioration of characteristics is caused.

According to the present invention, a method of forming a single-crystalline thin film of a prescribed material on a substrate comprises a step of depositing the prescribed material on the substrate thereby forming a thin film of the material, a step of irradiating the thin film with a gas beam of low energy causing  
40 no sputtering of the prescribed material under a high temperature below a crystallization temperature of the prescribed material from one direction after the step, thereby converting the thin film to an axially oriented polycrystalline thin film, and a step of irradiating the axially oriented polycrystalline thin film with gas beams of low energy causing no sputtering of the prescribed material under a high temperature below the crystallization temperature of the prescribed material from directions which are perpendicular to a plurality  
45 of densest crystal planes of different directions in the single-crystalline thin film, thereby converting the axially oriented polycrystalline thin film to a single-crystalline thin film.

The axially oriented polycrystalline thin film is previously formed on the substrate and thereafter irradiated with the beams from a plurality of directions, so that the thin film is converted to a single-crystalline thin film. Therefore, even if the substrate is not uniformly irradiated with the beams from the  
50 plurality of directions due to a screen formed on the substrate, for example, at least either a single-crystalline thin film or an axially oriented polycrystalline thin film is formed on any portion on the substrate, whereby no remarkable deterioration of characteristics is caused.

The direction of the gas beam in formation of the axially oriented polycrystalline thin film is preferably identical to one of the plurality of directions of the gas beams in the conversion of the axially oriented  
55 polycrystalline thin film to the single-crystalline thin film.

The direction of application of the gas beam in formation of the axially oriented polycrystalline thin film is identical to one of the plurality of directions of gas beams for converting the axially oriented polycrystalline thin film to a single-crystalline thin film, whereby conversion to the single-crystalline thin film is

smoothly carried out.

The gas is preferably an inert gas.

The beam of an inert gas is so applied that no particularly remarkable influence is exerted on the electrophysical properties of the thin film even if the gas remains in the single-crystalline thin film as  
5 formed, while it is possible to easily remove the as-invaded gas from the thin film.

The atomic weight of an element forming the inert gas is preferably lower than the maximum atomic weight among those of elements forming the prescribed material.

The atomic weight of the element forming the inert gas is lower than the maximum atomic weight of elements forming the prescribed material which is grown as the thin film, whereby most part of atoms or  
10 ions of the applied inert gas are rearwardly scattered on the surface of the thin film or in the vicinity thereof, to hardly remain in the thin film.

The prescribed material preferably contains an element forming a gas material which is a gas under a normal temperature, and the gas beam is preferably a beam of the gas material.

The gas as applied contains an element forming the material grown as a thin film. Even if atoms or ions  
15 of the element remain in the thin film after irradiation, therefore, these will not exert a bad influence on the single-crystalline thin film as impurities.

The gas beam is preferably formed by an electron cyclotron resonance ion source.

The beam generation source is an electron cyclotron resonance ion generation source. Therefore, the ion beam has high directivity, while a strong neutral beam can be obtained at a distance exceeding a  
20 prescribed length from the ion generation source without employing means for neutralizing ions. Further, it is possible to employ an electrically insulating substrate without employing means for neutralizing the ions.

According to the present invention, a beam irradiator for irradiating a target surface of a sample with a gas beam comprises a single beam source for supplying the beam, and reflecting means for reflecting the beam which is supplied by the beam source, thereby enabling irradiation of the target surface with the gas  
25 in a plurality of prescribed directions of incidence, and the reflecting means comprises a reflector having a plurality of reflecting surfaces for reflecting the beam in a plurality of directions, and a screen which is interposed in a path of the beam between the beam source and the reflecting surfaces for selectively passing the beam thereby preventing multiple reflection by the plurality of reflecting surfaces.

Multiple reflection of the beam by the plurality of reflecting surfaces is prevented by the screen,  
30 whereby no beam is applied from a direction other than a prescribed direction of incidence.

The screen preferably further selectively passes the beam to uniformly irradiate the target surface with the beam.

The target surface is uniformly irradiated with the beam by action of the screen. Therefore, a high quality single-crystalline thin film is formed when the apparatus is applied to formation of a single-crystalline  
35 thin film, for example.

The present invention is also directed to a beam reflecting device. According to the present invention, a beam reflecting device for reflecting a gas beam which is supplied from a single beam source thereby enabling irradiation of a target surface of a sample with the gas in a plurality of prescribed directions of incidence comprises a reflector having a plurality of reflecting surfaces for reflecting the beam in a plurality  
40 of directions, and a screen which is interposed in a path of the beam between the beam source and the reflecting surfaces for selectively passing the beam thereby preventing multiple reflection by the plurality of reflecting surfaces.

Multiple reflection of the beam by the plurality of reflecting surfaces is prevented by the screen, whereby no beam is applied from a direction other than a prescribed direction of incidence.

45 The screen preferably further selectively passes the beam to uniformly irradiate the target surface with the beam.

The target surface is uniformly irradiated with the beam by action of the screen. Therefore, a high-quality single-crystalline thin film is formed when the apparatus is applied to formation of a single-crystalline thin film, for example.

50 According to the present invention, a beam irradiator for irradiating a target surface of a sample with a gas beam comprises a single beam source for supplying the beam, and reflecting means for reflecting the beam which is supplied by the beam source, thereby enabling irradiation of the target surface with the gas in a plurality of prescribed directions of incidence, and the reflecting means comprises a first reflector which is arranged in a path of the beam supplied from the beam source for reflecting the beam in a plurality of  
55 directions thereby generating a plurality of divergent beams having beam sections which are two-dimensionally enlarged with progress of the beams, and a second reflector having a concave reflecting surface for further reflecting the plurality of divergent beams to be incident upon the target surface substantially as parallel beams from a plurality of directions.

The gas beams applied to the target surface of the sample are obtained by the single beam source and the reflecting means provided in the path, whereby it is possible to irradiate the target surface with gas beams from a plurality of different prescribed directions with no requirement for a plurality of beam sources. Further, the beam is reflected by the first reflector to be two-dimensionally diverged in a plurality of directions and then converted to substantially parallel beams by the second reflector, whereby the beam can be uniformly applied to the target surface which is wider than the section of the beam supplied from the beam source. Therefore, it is possible to widely and efficiently form a single-crystalline thin film of a prescribed material on a wide substrate provided with a thin film of the prescribed material on its surface or a wide substrate having a thin film of the prescribed material being grown on its surface without scanning the substrate, by irradiating the substrate with a gas beam by this apparatus.

The reflecting means preferably further comprises rectifying means which is provided in a path of the beams between the first reflector and the substrate for regularizing directions of the beams.

The rectifying means is arranged in the path of the beam between the first reflector and the sample, whereby the beam can be regulated along a prescribed direction. Therefore, no strict accuracy is required for the shapes and arrangement of the respective reflectors, whereby the apparatus can be easily structured.

The reflecting means preferably further comprises beam distribution adjusting means which is interposed in a path of the beam between the beam source and the first reflector for adjusting distribution of the beam on a section which is perpendicular to the path, thereby adjusting the amounts of respective beam components reflected by the first reflector in the plurality of directions.

The beam distribution adjusting means adjusts the amounts of a plurality of beam components reflected by the first reflector, whereby the amounts of a plurality of beam components which are incident upon the target surface from a plurality of directions can be adjusted. Therefore, the amounts of the respective beam components incident upon the substrate can be optimally set to be identical to each other, for example, whereby it is possible to efficiently form a high-quality single-crystalline thin film.

According to the present invention, a beam reflecting device for reflecting a gas beam which is supplied from a single beam source thereby enabling irradiation of a target surface of a sample with the gas in a plurality of prescribed directions of incidence comprises a first reflector for reflecting the beam in a plurality of directions thereby generating a plurality of divergent beams having beam sections which are two-dimensionally enlarged with progress of the beams, and a second reflector having a concave reflecting surface for further reflecting the plurality of divergent beams to be incident upon the target surface substantially as parallel beams from a plurality of directions.

The gas beam which is supplied from the single beam source is reflected by the first reflector to be two-dimensionally diverged in a plurality of directions and then converted to substantially parallel beams by the second reflector, whereby it is possible to irradiate the target surface which is wider than the section of the beam supplied from the beam source from a plurality of directions with no requirement for a plurality of beam sources. Therefore, it is possible to widely and efficiently form a single-crystalline thin film of a prescribed material on a wide substrate provided with a thin film of the prescribed material on its surface or a wide substrate having a thin film of the prescribed material being grown on its surface without scanning the substrate, by irradiating the substrate with a gas beam by this apparatus.

According to the present invention, a beam irradiator for irradiating a target surface of a sample with gas beams comprises a plurality of beam sources for supplying the gas beams, and a plurality of reflecting means for reflecting the beams which are supplied by the plurality of beam sources thereby enabling irradiation of a common region of the target surface with the gas in a plurality of prescribed directions of incidence, and each reflecting means comprises a first reflector which is arranged in a path of each beam supplied from each beam source for reflecting the beam thereby generating a beam having a beam section which is two-dimensionally enlarged with progress of the beam, and a second reflector having a concave reflecting surface for further reflecting the divergent beam to be incident upon a linear or strip-shaped common region of the target surface substantially as a parallel beam, while the beam irradiator further comprises moving means for scanning the sample in a direction intersecting with the linear or strip-shaped common region.

The beams are reflected by the first reflector to be substantially one-dimensionally diverged and thereafter converted to substantially parallel beams by the second reflector, whereby it is possible to irradiate a linear or strip-shaped region which is wider than the beams supplied from the beam sources with parallel beams from prescribed directions of incidence. Further, the sample is scanned in a direction intersecting with the linear or strip-shaped region, whereby the beams can be uniformly applied to a wide target surface. In addition, a plurality of beam sources and a plurality of reflecting means are so provided that a wide target surface can be uniformly irradiated with beams from a plurality of directions of incidence.

Each reflecting means preferably further comprises rectifying means which is provided in a path of each beam between the first reflector and the substrate for regulating the direction of the beam.

The rectifying means is arranged in the beam path between the first reflector and the substrate, whereby the beams can be regulated in a prescribed direction. Therefore, no strict accuracy is required for the shapes and arrangement of the respective reflectors, whereby the apparatus can be easily structured.

According to the present invention, a beam reflecting device for reflecting a gas beam which is supplied from a beam source thereby enabling irradiation of a target surface of a sample with the gas in a prescribed direction of incidence comprises a first reflector for reflecting the beam thereby generating a divergent beam having a beam section which is two-dimensionally enlarged with progress of the beam, and a second reflector having a concave reflecting surface for further reflecting the divergent beam to be incident upon a linear or strip-shaped region of the target surface substantially as a parallel beam.

The beams are reflected by the first reflector to be substantially one-dimensionally diverged and thereafter converted to substantially parallel beams by the second reflector, whereby it is possible to irradiate a linear or strip-shaped region which is wider than the beams supplied from the beam sources with the beams.

Accordingly, an object of the present invention is to provide a technique which can form an axially oriented polycrystalline thin film oriented in a desired direction and a single-crystalline thin film having a desired crystal orientation on an arbitrary substrate including a single-crystalline substrate.

Another object of the present invention is to provide a beam irradiator and a beam reflecting device for enabling efficient formation of a single-crystalline thin film.

Throughout the specification, the term "substrate" is not restricted to a substance simply serving as a base to be provided thereon with a thin film, but generally indicates a medium to be provided thereon with a thin film, including a device having a prescribed function, for example.

Throughout the specification, the term "gas beam" is a concept including all of a beam-type ion current, an atom current and a molecular flow.

The foregoing and other objects, features, aspects and advantages of the present invention will become more apparent from the following detailed description of the present invention when taken in conjunction with the accompanying drawings.

#### BRIEF DESCRIPTION OF THE DRAWINGS

- Fig. 1 is a model diagram showing an apparatus which is suitable for carrying out a method according to a first preferred embodiment of the present invention;
- Figs. 2A to 2C are perspective views showing a structure of a collimator;
- Figs. 3A and 3B are sectional views showing a sample;
- Fig. 4 is a front sectional view showing an apparatus which is suitable for carrying out a method according to a second preferred embodiment of the present invention;
- Fig. 5 is a perspective view showing a reflector which is employed in the method according to the second preferred embodiment of the present invention;
- Figs. 6A, 6B and 6C are a plan view, a side elevational view and a front elevational view showing an example of the reflector which is employed in the method according to the second preferred embodiment of the present invention;
- Fig. 7 is a graph showing characteristics of an ECR ion generator which is employed in the method according to the second preferred embodiment of the present invention;
- Fig. 8 illustrates experimental data verifying the method according to the second preferred embodiment of the present invention;
- Fig. 9 is a perspective view showing another example of the reflector employed in the method according to the second preferred embodiment of the present invention;
- Figs. 10A, 10B and 10C illustrate three surfaces of still another example of the reflector employed in the method according to the second preferred embodiment of the present invention;
- Figs. 11A and 11B are structural diagrams showing a further example of the reflector employed in the method according to the second preferred embodiment of the present invention;
- Figs. 12A and 12B are structural diagrams showing a further example of the reflector employed in the method according to the second preferred embodiment of the present invention; and
- Fig. 13 is a front sectional view showing an apparatus which is suitable for carrying out a method according to a preferred embodiment of the present invention.
- Fig. 14 is a front sectional view showing an apparatus according to a fourth preferred embodiment of the present invention;

- Fig. 15 illustrates a result of a verification test in the apparatus according to the fourth preferred embodiment of the present invention;
- Fig. 16 is a front sectional view showing an apparatus according to a fifth preferred embodiment of the present invention;
- 5 Fig. 17 is a perspective view showing a reflector in the fifth preferred embodiment;
- Fig. 18 is a plan view of the reflector shown in Fig. 17;
- Fig. 19 is an exploded perspective view of the reflector shown in Fig. 17;
- Fig. 20 is an exploded perspective view of the reflector shown in Fig. 17;
- Fig. 21 is a plan view of the reflector shown in Fig. 17;
- 10 Fig. 22 is a sectional view taken along the line A - A in Fig. 21;
- Fig. 23 is a perspective view showing an apparatus according to a sixth preferred embodiment of the present invention;
- Fig. 24 is a perspective view showing an apparatus according to a seventh preferred embodiment of the present invention;
- 15 Fig. 25 is a process diagram for illustrating a method according to an eighth preferred embodiment of the present invention;
- Fig. 26 is a process diagram for illustrating the method according to the eighth preferred embodiment of the present invention;
- Fig. 27 is a process diagram for illustrating the method according to the eighth preferred embodiment of the present invention;
- 20 Fig. 28 is a front sectional view of an apparatus according to a ninth preferred embodiment of the present invention;
- Fig. 29 is a front sectional view showing a reflecting unit in the ninth preferred embodiment of the present invention;
- 25 Fig. 30 is a plan view showing a reflecting unit in the ninth preferred embodiment;
- Fig. 31 is a front sectional view showing an apparatus according to a tenth preferred embodiment of the present invention;
- Fig. 32 is a perspective view showing an apparatus according to an eleventh preferred embodiment of the present invention;
- 30 Fig. 33 is a plan view showing the apparatus according to the eleventh preferred embodiment of the present invention;
- Fig. 34 is a front elevational view of the apparatus according to the eleventh preferred embodiment of the present invention;
- Fig. 35 is a plan view of the apparatus according to the eleventh preferred embodiment of the present invention; and
- 35 Fig. 36 is a perspective view showing an apparatus according to a twelfth preferred embodiment of the present invention.
- Fig. 37 is a process diagram showing a method according to a thirteenth preferred embodiment of the present invention;
- 40 Fig. 38 is a process diagram showing the method according to the thirteenth preferred embodiment of the present invention;
- Fig. 39 is a process diagram showing the method according to the thirteenth preferred embodiment of the present invention;
- Fig. 40 is a process diagram showing the method according to the thirteenth preferred embodiment of the present invention;
- 45 Fig. 41 is a process diagram showing the method according to the thirteenth preferred embodiment of the present invention;
- Fig. 42 is a process diagram showing the method according to the thirteenth preferred embodiment of the present invention;
- 50 Fig. 43 is a process diagram showing a method according to a fourteenth preferred embodiment of the present invention;
- Fig. 44 is a process diagram showing the method according to the fourteenth preferred embodiment of the present invention;
- 55 Fig. 45 is a process diagram showing the method according to the fourteenth preferred embodiment of the present invention;
- Fig. 46 is a process diagram showing the method according to the fourteenth preferred embodiment of the present invention;

- Fig. 47 is a process diagram showing the method according to the fourteenth preferred embodiment of the present invention;
- Fig. 48 is a process diagram showing the method according to the fourteenth preferred embodiment of the present invention;
- 5 Fig. 49 is a process diagram showing the method according to the fourteenth preferred embodiment of the present invention;
- Fig. 50 is a process diagram showing the method according to the fourteenth preferred embodiment of the present invention;
- Fig. 51 is a process diagram showing the method according to the fourteenth preferred embodiment of the present invention;
- 10 Fig. 52 is a process diagram showing a method according to a seventeenth preferred embodiment of the present invention;
- Fig. 53 is a process diagram showing the method according to the seventeenth preferred embodiment of the present invention;
- 15 Fig. 54 is a process diagram showing the method according to the seventeenth preferred embodiment of the present invention;
- Fig. 55 is a process diagram showing the method according to the seventeenth preferred embodiment of the present invention;
- Fig. 56 is a process diagram showing the method according to the seventeenth preferred embodiment of the present invention;
- 20 Fig. 57 is a process diagram showing the method according to the seventeenth preferred embodiment of the present invention;
- Fig. 58 is a process diagram showing the method according to the seventeenth preferred embodiment of the present invention;
- 25 Fig. 59 is a process diagram showing the method according to the seventeenth preferred embodiment of the present invention;
- Fig. 60 is a process diagram showing the method according to the seventeenth preferred embodiment of the present invention;
- Fig. 61 is a process diagram showing a method according to an eighteenth preferred embodiment of the present invention;
- 30 Fig. 62 is a front elevational view showing an apparatus according to a nineteenth preferred embodiment of the present invention;
- Fig. 63 is a plan view showing the apparatus according to the nineteenth preferred embodiment of the present invention;
- 35 Fig. 64 is a front sectional view showing the apparatus according to the nineteenth preferred embodiment of the present invention;
- Fig. 65 is a perspective view showing the apparatus according to the nineteenth preferred embodiment of the present invention;
- Fig. 66 is a front elevational view showing an apparatus according to a twentieth preferred embodiment of the present invention;
- 40 Fig. 67 is a plan view showing an apparatus according to a twenty-first preferred embodiment of the present invention;
- Fig. 68 is a plan view showing an apparatus according to a twenty-third preferred embodiment of the present invention;
- 45 Fig. 69 is a front sectional view showing an apparatus according to a twenty-fourth preferred embodiment of the present invention;
- Fig. 70 is a front sectional view showing another apparatus according to the twenty-fourth preferred embodiment of the present invention;
- Fig. 71 is a partially fragmented sectional view showing an apparatus according to a twenty-fifth preferred embodiment of the present invention;
- 50 Fig. 72 is a plan view showing another apparatus according to the twenty-fifth preferred embodiment of the present invention;
- Fig. 73 is a front sectional view showing an apparatus according to a twenty-sixth preferred embodiment of the present invention;
- 55 Fig. 74 is a front sectional view showing an apparatus according to a twenty-seventh preferred embodiment of the present invention;
- Fig. 75 is a front sectional view showing an apparatus according to a twenty-eighth preferred embodiment of the present invention; and

Fig. 76 is a front sectional view showing an apparatus according to a twenty-ninth preferred embodiment of the present invention.

#### DESCRIPTION OF THE PREFERRED EMBODIMENTS

##### (A. Formation of Single-Crystalline Thin Film or Axially Oriented Polycrystalline Thin Film)

Preferred embodiments for efficiently forming a single-crystalline thin film or axially oriented polycrystalline thin film on a substrate are now described.

##### (A-1. First Preferred Embodiment)

A first preferred embodiment of the present invention is now described.

##### (A-1-1. Structure of Apparatus)

Fig. 1 is a model diagram showing the structure of an apparatus 80 for effectively implementing a method according to the first preferred embodiment of the present invention. This apparatus 80 is adapted to convert a polycrystalline thin film 82, which is formed on a substrate 81, to a single-crystalline thin film. Therefore, the apparatus 80 is supplied with a sample prepared by the polycrystalline thin film 82 of a prescribed material which is already formed on the substrate 81 by a well-known method.

For example, the substrate 81 is prepared from polycrystalline  $\text{SiO}_2$  (quartz), and a polycrystalline Si (silicon) thin film 82 is formed on this quartz substrate 81, to be converted to a single-crystalline Si thin film. The apparatus 80 comprises cage-type ion sources 83. Inert gases are introduced into the ion sources 83 from conduits 84 and ionized therein by electron beams, thereby forming plasmas of the inert gases. Further, only ions are extracted from the ion sources 83 by action of electric fields which are formed by lead electrodes provided in the ion sources 83, whereby the ion sources 83 emit ion beams. For example, it is possible to accelerate Ne (neon) ions to 200 to 600 eV by the ion sources 83 of 10 cm in diameter, for example, with current densities of 1 to 9 mA/cm<sup>2</sup>.

The ion beams which are emitted from the ion sources 83 are guided to reflection deaccelerators 85 and collimators 86, and thereafter applied to the surface of the polycrystalline thin film 82 at prescribed angles. Each reflection deaccelerator 85 is provided with two silicon single-crystalline plates having major surfaces of (100) planes. These silicon single-crystalline plates are in the form of discs having diameters of 15 cm, for example. These silicon single-crystalline plates successively reflect the ion beams which are incident on the major surfaces thereof at angles of incidence of 45° to reduce energy levels and neutralize electric charges thereof, thereby converting the ion beams to low-energy neutral atomic beams.

Figs. 2A to 2C are perspective views showing the structure of each collimator 86. Fig. 2A is an overall perspective view, Fig. 2B is an enlarged perspective view and Fig. 2C is a further enlarged perspective view. The collimator 86 regulates directions of the atomic beams, thereby supplying the polycrystalline thin film 82 with atomic beams having high directivity. The collimator 86 is formed by alternately stacking corrugated members, which are prepared by evaporating silicon films 86b on both sides of aluminum plates 86a as shown in Fig. 2C, and flat plate members having similar structures as shown in Fig. 2B. This collimator 86 has 30 layers, for example. Both surfaces of the aluminum plates 86a are covered with the silicon films 86b, so that aluminum atoms which are different atoms will not reach the polycrystalline Si thin film 82 even if the corrugated members and the flat plate members are struck by a neutral atom current to cause sputtering. The atomic beams are regularized in direction within a range of  $\pm 0.5^\circ$  while passing through thin channels defined between the corrugated and flat plate members, to be converted to atomic beams having high directivity.

The quartz substrate 81 is mounted on a heater 87, which is adapted to maintain the quartz substrate 81 at a prescribed high temperature.

##### (A-1-2. Operation of Apparatus)

The operation of the apparatus 80 is now described. The sample which is supplied to the apparatus 80 can be prepared by forming the polycrystalline Si thin film 82 on the quartz substrate 81 by well-known chemical vapor deposition (CVD), for example. The quartz substrate 81 is 1.5 mm in thickness, for example, and the polycrystalline Si thin film 82 is about 2000 Å in thickness, for example. First, the sample as prepared is mounted on the heater 87. This heater 87 maintains the sample, i.e., the quartz substrate 81



and the polycrystalline Si thin film 82, at a temperature of 550 °C. This temperature is lower than the crystallization temperature of silicon, whereby no single-crystalline Si is converted to polycrystalline Si under this temperature. However, this temperature is so high that polycrystalline Si can be grown to single-crystalline Si if a seed crystal is present.

5 Then, Ne (neon) gases are introduced into the ion sources 83 from the conduits 84, to form Ne ion beams. The as-formed Ne ion beams pass through the reflection deaccelerators 85 and the collimators 86, to reach the surface of the polycrystalline Si thin film 82 as low energy neutral Ne atomic beams.

The two Ne atomic beams which are started from the two ion sources 83 are incident upon the surface of the polycrystalline Si thin film 82 at angles of incidence of 35 ° so that the directions of incidence are  
10 two-fold symmetrical with each other about a normal line on the surface of the polycrystalline Si thin film 82. The directions of incidence of these two beams, which are at an angle of 70 ° to each other, correspond to normal line directions of independent two densest planes, i.e., (111) planes of single-crystalline Si having a diamond crystal structure.

The energy levels of the plasmas formed by the ion sources 83 are so set that the Ne atoms reaching  
15 the polycrystalline Si thin film 82 are at levels causing no sputtering of the polycrystalline Si thin film 82, i.e., at levels lower than a value (= 27 eV) known as a threshold energy level in sputtering of Si caused by irradiation with Ne atoms. Therefore, the so-called law of Bravais acts on the polycrystalline Si thin film 82. Namely, Si atoms provided in the vicinity of the surface of the polycrystalline Si thin film 82 are so  
20 rearranged that planes perpendicular to the directions of incidence of the Ne atomic beams which are applied to the polycrystalline Si thin film 82 define densest crystal planes.

Since the Ne atomic beams are incident from two directions corresponding to those perpendicular to the independent densest planes of the single-crystalline Si, whereby the Si atoms are so rearranged that planes perpendicular to the directions of incidence define the densest planes. Namely, two independent  
25 (111) planes are controlled by the two Ne atoms beams having independent directions of incidence to be rearranged in constant directions, whereby the crystal orientation is univocally decided. Thus, a layer which is close to the surface of the polycrystalline Si thin film 82 is converted to a single-crystalline Si layer having a regulated crystal orientation.

The above description corresponds to a first stage of single-crystallization of the polycrystalline Si thin film 82. Figs. 3A and 3B are model diagrams showing internal structures of the sample in the first stage and  
30 a following second stage of single-crystallization. In the first stage, a single-crystalline Si layer 88 is formed only in the vicinity of the surface of the polycrystalline Si thin film 82, as shown in Fig. 3A.

As hereinabove described, the temperature of the polycrystalline Si thin film 82 is adjusted to a level which is suitable for growing a seed crystal. Therefore, the single-crystalline Si layer 88 which is formed on the surface of the polycrystalline Si thin film 82 serves as a seed crystal, to be grown toward a deep portion  
35 of the polycrystalline Si thin film 82. Finally the overall region of the polycrystalline Si thin film 82 is converted to the single-crystalline Si layer 88, as shown in Fig. 3B. Thus, a single-crystalline Si thin film having a regulated crystal orientation is formed on the quartz substrate 81. Since the polycrystalline Si thin film 82 is maintained at a temperature which is lower than the crystallization temperature of Si as hereinabove described, the single-crystalline Si layer 88 will not return to the polycrystalline structure, which  
40 is a thermal equilibrium state.

The single-crystalline Si layer 88, which is formed on the polycrystalline Si thin film 82 by irradiation to serve as a seed crystal, is integrated with a polycrystalline Si layer remaining in its deep portion since this layer 88 is converted from the polycrystalline Si thin film 82. Namely, the polycrystalline Si layer 82 is completely in contact with the seed crystal. Therefore, vertical solid phase epitaxial growth progresses in an  
45 excellent state. Further, the seed crystal and the single-crystalline Si which is formed by the solid phase epitaxial growth are single crystals of the same material having the same crystal orientation, whereby it is not necessary to remove the seed crystal after formation of the single-crystalline Si thin film 88. Further, the single-crystalline Si thin film 88 is formed by the vertical solid phase epitaxial growth, whereby it is possible to efficiently obtain a desired single-crystalline Si thin film in a short time as compared with the prior art  
50 utilizing transverse growth.

An element forming the atomic beams which are applied to the polycrystalline Si thin film 82 is preferably prepared from Ne, as hereinabove described. Since Ne atoms are lighter than Si atoms, there is a high possibility that the relatively heavy Si atoms rearwardly scatter the relatively light Ne atoms when the atomic beams are applied to the Si thin film, whereby the Ne atoms hardly penetrate into the Si thin film to  
55 remain therein. Further, the inert element such as Ne is selected as an element forming the as-applied atomic beams since the inert element forms no compound with any element forming the thin film such as Si even if the same remains in the Si thin film, whereby the electronic/physical properties of the Si thin film are hardly influenced by this element and this element can be easily removed by increasing the temperature of

the as-finished single-crystalline Si thin film to some extent.

The sample is irradiated with the neutralized atomic beams in place of direct Ne ion beams, for the following reasons: First, charged particle beams such as ion beams are spread to lose directivity by repulsion between the particles caused by static electricity. Second, charges are stored in the thin film when charged particle beams are employed for the thin film which is made of a material having high resistivity or the like, such that the beams cannot reach the thin film beyond a certain amount due to repulsion of the stored charges. When neutral atomic beams are employed, on the other hand, no charges are stored in the thin film while parallel beams having excellent directivity reach the thin film to facilitate smooth crystallization.

10

#### (A-1-3. Other Exemplary Sample)

While the above description has been made on the case of converting the polycrystalline Si thin film 82 to a single-crystalline Si thin film, the inventive method is applicable not only to a polycrystalline thin film but to an amorphous thin film, to attain a similar effect. Experimental data verifying this point is now described.

15

In the experiment, a sample was prepared by previously forming an amorphous Si thin film on a quartz substrate by plasma CVD. Inert gases to be applied to the sample were prepared from Ne gases. The quartz substrate was 1.5 mm in thickness, and the amorphous Si thin film was about 2000 Å in thickness. This sample was mounted on the heater 87, and maintained at a temperature of 550 °C. In this state, the sample was irradiated with beams for about 20 seconds under conditions of acceleration voltages of ion sources of 2000 V and current densities of 2 mA/cm<sup>2</sup>. As the result, a brown color specific to amorphous Si disappeared from the as-irradiated central portion of the sample, and this portion was changed to a slightly yellowish transparent state. In this portion, a part of about 1 cm<sup>2</sup> was examined with X rays and by directive etching, whereby it was provide that single-crystalline Si was formed with (110) axes along a normal line direction of the substrate.

20

The crystal orientation was decided by covering the crystal planes with SiO<sub>2</sub> (silicon dioxide) films, forming small holes in these oxide films, etching the same with KOH (potassium hydroxide) and confirming etching bits. As the result, it was possible to confirm that the etching bits were hexagonal, thereby confirming that single-crystalline Si having (110) axes in the normal line direction was completed.

25

#### (A-2. Second Preferred Embodiment)

A second preferred embodiment of the present invention is now described.

35

#### (A-2-1. Overall Structure of Apparatus)

Fig. 4 is a front sectional view showing an apparatus 101 for effectively implementing a method according to the second preferred embodiment of the present invention. This apparatus 101 is also adapted to convert a polycrystalline thin film, which is previously formed on a substrate 11, to a single-crystalline thin film, similarly to the aforementioned apparatus 80.

40

This apparatus 101 comprises a reaction vessel 1, and an electron cyclotron resonance (ECR) ion generator 2 which is built in an upper portion of the reaction vessel 1. The ECR ion generator 2 comprises a plasma container 3 which defines a plasma chamber 4 in its interior. A magnetic coil 5 is provided around the plasma container 3, to apply a dc high magnetic field to the plasma chamber 4. Further, a waveguide 6 and an inlet pipe 7 are provided on an upper surface of the plasma container 3 for introducing a microwave and an inert gas such as Ne gas into the plasma chamber 4 respectively.

45

The reaction vessel 1 defines an reaction chamber 8 in its interior. The bottom portion of the plasma container 3 defines an outlet 9 for passing a plasma in its center. The reaction chamber 8 and the plasma chamber 4 communicate with each other through the outlet 9. In the interior of the reaction chamber 8, a sample holder 10 is arranged on a position immediately under the outlet 9. The substrate 11 is placed on the sample holder 10, while a reflector 12 is placed to be located above the substrate 11. The sample holder 10 comprises a heater (not shown), to heat the substrate 11 and hold the same at a proper high temperature level.

50

The reflector 12 is preferably made of a metal. The sample holder 10 is coupled to a rotation driving mechanism (not shown), to be rotatable in a horizontal plane. Further, the sample holder 10 can horizontally move the substrate 11 while fixing the reflector 12.

55

The reaction chamber 8 communicates with an evacuation pipe 14. An end of the evacuation pipe 14 is coupled with a vacuum unit (not shown) to evacuate the reaction chamber 8 through the evacuation pipe 14, thereby maintaining the reaction chamber 8 at a prescribed degree of vacuum. A vacuum gauge 15 for displaying the degree of vacuum in the reaction chamber 8 is provided in communication with the reaction chamber 8.

#### (A-2-2. Structure of Reflector)

Fig. 5 is a perspective view showing an exemplary reflector 12a. This reflector 12a is adapted to form a single crystal having a diamond structure, such as single-crystalline Si. The reflector 12a defines an opening on a central portion of a flat plate type base 21. Three blocks 22 in the form of rectangular parallelepipeds are fixedly provided around the opening, and reflecting blocks 23 are fixed to inner sides of the blocks 22 respectively. Consequently, an equilateral triangular opening 24 which is trimmed with the reflecting blocks 23 is defined at the central portion of the base 21. In the reflecting blocks 23, slopes 25 facing the opening 24 serve as reflecting surfaces for reflecting a gas beam. Therefore, the angles of inclination of the slopes 25 are set at proper levels in correspondence to the directions of crystal axes of the single crystal to be formed.

Figs. 6A, 6B and 6C are a plan view, a side elevational view and a front elevational view of the reflector 12a which is formed by the blocks 22 and the reflecting blocks 23 respectively. As shown in Fig. 6B, the angle of inclination of each slope 25 is set at  $55^\circ$ . The reflector 12a is in a structure not fixing the substrate 11, whereby the substrate 11 can be relatively horizontally moved with respect to the reflector 12a. Therefore, it is possible to form a single-crystalline thin film on the substrate 11 having a large area by horizontally moving the substrate 11 while fixing the reflector 12a on the sample holder 10.

#### (A-2-3. Operation of ECR Ion Generator)

Referring again to Fig. 4, the operation of the ECR ion generator 2 is now described. An inert gas such as Ne gas or Ar gas is introduced from the inert gas inlet pipe 7 into the plasma chamber 4, while a microwave is simultaneously introduced from the waveguide 6 into the plasma chamber 4. Further, a dc current is also simultaneously supplied to the magnetic coil 5, to form a dc magnetic field in the plasma chamber 4 and its periphery. The gas as supplied is maintained in a plasma state by actions of the microwave and the dc magnetic field. This plasma is formed by high-energy electrons which are in screw motion in the principle of cyclotron by the microwave and the dc magnetic field.

These electrons, which have diamagnetic properties, are moved to a weaker magnetic field side, to form an electron stream along a line of magnetic force. Consequently, positive ions also form an ion current along the line of magnetic force following the electron stream, in order to maintain electrical neutrality. In other words, the electron stream and the ion current are downwardly directed from the outlet 9 into the reaction chamber 8. The ion current and the electron stream thus flowing in parallel with each other are recombined with each other after a lapse of a deionization time, to form a neutral atom current. Therefore, substantially only a neutral atom current is formed in a position downwardly separated from the outlet 9 beyond a prescribed distance.

Fig. 7 is a graph showing the result of relation between ion current density and the distance from the outlet 9 actually measured when  $\text{Ar}^+$  ions of 10 eV were discharged from the outlet 9 by the ECR ion generator 2. It is understood from this graph that the ion current density is abruptly reduced at a distance of about 4 to 5 cm from the outlet 9, and attenuated to a level of 1/10 to 1/12 at a position of 14 cm. The neutral atom current is increased by such attenuation of the ion current, whereby substantially only a neutral atom current downwardly flows in a position downwardly separated from the outlet 9 by at least 14 cm.

Thus, the ECR ion generator 2 for generating ions forms an ion current in parallel with the electron stream, whereby it is possible to easily obtain a neutral atom current having high density by employing the ECR ion generator 2, with no employment of other means for neutralizing the ion current. Since the ion current is formed in parallel with the electron stream, further, it is possible to obtain an ion current which is close to a parallel current having a regulated direction of progress substantially with no divergence. Since the parallel ion current is converted to the neutral atom current, the atom current is also close to a parallel current having a regulated direction of progress.

55

## (A-2-4. Operation of Apparatus 101)

Referring again to Fig. 4, the operation of the apparatus 101 is now described. It is assumed that the reflector 12 is implemented by the reflector 12a shown in Figs. 5 and 6A to 6C and the substrate 11 is prepared from polycrystalline SiO<sub>2</sub> (quartz), so that a single-crystalline Si thin film is formed on the quartz substrate 11. A polycrystalline Si thin film is previously formed on the quartz substrate 11 by a well-known method such as CVD.

First, the sample is mounted between the sample holder 10 and the reflector 12a (12). The heater provided in the sample holder 10 holds the sample, i.e., the quartz substrate 11 and the polycrystalline Si thin film, at a temperature similar to that in the first preferred embodiment, i.e., a temperature of 550 °C.

An inert gas which is introduced from the inert gas inlet pipe 7 is preferably prepared from Ne gas having a smaller atomic weight than Si atoms. Due to the action of the ECR ion generator 2, an Ne<sup>+</sup> ion current and an electron stream are formed downwardly from the outlet 9. The distance between the outlet 9 and the reflector 12a (12) is preferably set at a sufficient level for substantially converting the Ne<sup>+</sup> ion current to a neutral Ne atom current. The reflector 12a (12) is set in a position receiving the downwardly directed Ne atom current.

A part of the downwardly directed Ne atom current is reflected by the three slopes 25 which are formed in the reflector 12a, to be applied to the polycrystalline Si thin film provided on the SiO<sub>2</sub> substrate 11 through the opening 24. Another part of the Ne atom current is not incident upon the slopes 25 but directly incident upon the polycrystalline Si thin film through the opening 24. In other words, the polycrystalline Si thin film is irradiated with four Ne atom current components, i.e., a component straightly received from the outlet 9 and three components reflected by the three slopes 25. Since the angles of inclination of the slopes 25 are set at 55°, directions of incidence of the four Ne atom current components correspond to four directions which are perpendicular to four independent densest crystal planes of the Si single crystal to be formed, i.e., (111) planes.

The energy of the plasma which is formed by the ECR ion generator 2 is so set that the Ne atoms reaching the SiO<sub>2</sub> substrate 11 are at energy levels which are lower than threshold energy (= 27 eV) in sputtering of Si by irradiation with Ne atoms. Therefore, the law of Bravais acts on the polycrystalline Si thin film. As the result, the Si atoms in the polycrystalline Si thin film are so rearranged that planes which are perpendicular to the direction of incidence of the Ne atomic current as applied define densest crystal planes. Since the Ne atom current as applied has four components which are incident in directions corresponding to those perpendicular to four independent densest planes of the single-crystalline Si, the Si atoms are so rearranged that all planes perpendicular to the directions of incidence define the densest planes. Namely, the directions of rearrangement of the four independent (111) planes are controlled by four Ne atomic beams having directions of incidence which are independent of each other, whereby the crystal orientation is univocally decided. Thus, a layer in the vicinity of the surface of the polycrystalline Si thin film is converted to a single-crystalline Si layer having a regulated crystal orientation.

The temperature of the polycrystalline Si thin film 82 is adjusted to 550 °C, i.e., a level within a range suitable for growing a seed crystal. Therefore, the single-crystalline Si layer which is formed on the surface of the polycrystalline Si thin film 82 serves as a seed crystal, to be grown toward a deep portion of the polycrystalline Si thin film 82. Then, the overall region of the polycrystalline Si thin film 82 is converted to a single-crystalline Si layer. Thus, a single-crystalline Si layer having a regulated crystal orientation is formed on the quartz substrate 11. The aforementioned Figs. 3A and 3B typically express the aforementioned formation of the single-crystalline Si layer and the process of its growth.

As hereinabove described, the reflector 12 is preferably made of a metal, since Ne<sup>+</sup> ions are converted to neutral atoms when an Ne<sup>+</sup> ion current which is slightly mixed in the neutral Ne atom current is reflected by the conductive reflector 12, so that the substrate 11 is irradiated with the as-converted neutral Ne atom current. The neutral atom current is advantageously incident upon the substrate 11 as a flow having a regulated direction since its direction of progress hardly diverges dissimilarly to an ion current.

In the process of irradiating the sample with the Ne atomic current, the rotation driving mechanism (not shown) may be driven to rotate the sample holder 10. Thus, it is possible to improve homogeneity in distribution of an amount of irradiation on the polycrystalline Si thin film.

## (A-2-5. Valid Data)

Description is now made on a test verifying formation of a single-crystalline thin film by the method according to the second preferred embodiment. Fig. 8 illustrate experimental data showing electron beam diffraction images of samples comprising polycrystalline SiO<sub>2</sub> substrates and single-crystalline Si thin films

formed thereon on the basis of the aforementioned method. The sample was obtained by irradiating a substrate with four Ne atom current components using a reflector.

In this sample, three-fold rotation-symmetrical diffraction spots were obtained as shown in Fig. 8. This verifies that the as-obtained sample was formed as single-crystalline Si having regulated crystal axes. Since it was possible to convert a polycrystalline Si thin film having a polycrystalline structure of higher regularity in atomic arrangement than an amorphous structure to a single-crystalline Si thin film, it is conceivably decided possible to convert a thin film having an amorphous structure such as amorphous Si to a single-crystalline thin film, as a matter of course.

10 (A-2-6. Methods of Forming Single-Crystalline Thin Films other than Si Thin Film)

While the structure and the operation of the apparatus 101 have been described with reference to formation of a single-crystalline Si thin film, it is also possible to form single-crystalline thin films other than an Si thin film through the apparatus 101.

15 Table 1

Gas Material for Crystal Forming Step	
for GaAs	
Ion Beam	Ar, Ne
Element	Ga(CH <sub>3</sub> ) <sub>3</sub> AsH <sub>3</sub>
Impurity	Zn(CH <sub>3</sub> ) <sub>3</sub> , Zn(C <sub>2</sub> H <sub>5</sub> ) <sub>3</sub> (p-type) SiH <sub>4</sub> (n-type)
for GaN	
Ion Beam	Ar, Ne, NH <sub>3</sub>
Element	Ga(CH <sub>3</sub> ) <sub>3</sub> NH <sub>3</sub>
Impurity	Zn(CH <sub>3</sub> ) <sub>3</sub> , Zn(C <sub>2</sub> H <sub>5</sub> ) <sub>3</sub> (p-type) SiH <sub>4</sub> (n-type)
for Si	
Ion Beam	Ne
Element	SiH <sub>4</sub> Si <sub>2</sub> H <sub>6</sub>
Impurity	B <sub>2</sub> H <sub>3</sub> (p-type) AsH <sub>3</sub> (n-type) PH <sub>3</sub> (n-type)

Table 1 shows values of sputtering threshold energy in various combinations of types of atoms or ions as applied and elements forming target thin films. In each combination, it is necessary to apply an ion current or an atom current which is at a lower energy level than the as-listed threshold energy. As to thin films formed by compounds, refer to threshold energy levels related to elements having the maximum atomic weights among the elements. The values shown in Table 1 have been obtained on the basis of simulation, unless otherwise stated.

When the thin film as irradiated is formed not by a simple substance such as Si but a compound such as GaAs, for example, it is advisable to apply atoms which are lighter than an element having the maximum atomic weight. Further, beams of a compound such as those of N<sub>2</sub> may be applied in place of beams of simple atoms, for example. In this case, an element (for example, N atoms) forming the compound is preferably lighter than the element having the maximum atomic weight forming the thin film as irradiated.

## (A-2-7. Other Examples of Reflector)

Description is now made on other exemplary structures of the reflector. Figs. 9 and 10A to 10C illustrate a reflector 12b for forming a single-crystalline thin film having a diamond crystal structure whose (111) planes define densest planes, similarly to the reflector 12a shown in Fig. 5. Fig. 9 is a perspective view of the reflector 12b, and Figs. 10A to 10C illustrate three surfaces thereof. This reflector 12b is provided with a groove 31a for sliding the substrate 11 on an upper surface of a base 31 which is mounted on the sample holder 10, so that the substrate 11 is built in the base 31. Therefore, the substrate 11 is fixed to the groove 31a when the same is irradiated, dissimilarly to the reflector 12a. Bottom surfaces of reflecting blocks 33 are placed on the upper surface of the base 31, so that the reflecting blocks 33 are located on the substrate 11. As shown in Fig. 10B, the angles of inclination of slopes 35 provided in the reflecting blocks 33 are set at  $55^\circ$ , similarly to those of the reflector 12a.

It is also possible to form a single-crystalline thin film having a crystal structure other than a diamond structure. In this case, still another reflector may be prepared to have a crystal structure which is suitable for the target crystal structure. Further, it is also possible to form a single-crystalline thin film having various crystal orientations in the same crystal structure. In this case, a reflector which is suitable for respective crystal orientations is prepared, as hereinafter described.

Figs. 11A and 11B illustrate an exemplary reflector 12c corresponding to a single crystal of a diamond structure, whose (100) planes are parallel to a substrate surface. Fig. 11A is a front sectional view taken along the line A - A in Fig. 11B, which is a plan view showing the reflector 12c. A groove 42 is formed on an upper surface of a flat plate type base 41. The substrate 11 is inserted in this groove 42. Namely, the reflector 12c is adapted to receive the substrate 11, which cannot be relatively horizontally moved with respect to the reflector 12c when the same is irradiated. This base 41 is placed on the sample holder 10.

Four reflecting blocks 43 are arranged on the base 41 around the substrate 11, to be perpendicularly adjacent to each other. A shielding plate 46 having openings 47 only above slopes 45 of the reflecting blocks 43 is set on upper surfaces of the reflecting blocks 43. An atom current or an ion current which is incident upon the shielding plate 46 downwardly from above passes through the openings 47 alone, to be entirely reflected by the slopes 45. Namely, only four components of the atom current or the ion current as reflected are incident upon the substrate 11, with no presence of a component which is directly incident from the above. The angles of inclination of the slopes 45 are set at  $62.63^\circ$ . Therefore, the directions of incidence of the four components match with directions perpendicular to four (111) planes, which are independent of each other, in the crystal of the diamond structure.

Figs. 12A and 12B illustrate a reflector 12d corresponding to a single crystal of a diamond structure whose (110) planes are parallel to a substrate surface. Fig. 12A is a front sectional view taken along the line B - B in Fig. 12B, which is a plan view showing the reflector 12d. A groove 52 is formed on an upper surface of a base 51 having an angle of inclination of  $35^\circ$ . The substrate 11 is inserted in this groove 52. Namely, this reflector 12d is adapted to receive the substrate 11, which cannot be relatively horizontally moved with respect to the reflector 12d when the same is irradiated. This base 51 is placed on the sample holder 10.

A single reflecting block 53 is arranged on the base 51. A slope 55 of the reflecting block 53 is set at an angle of inclination of  $90^\circ$  with respect to the upper surface of the base 51. Therefore, an atom current or an ion current which is incident from above is divided into two components including that which is directly incident upon the substrate 11 at an angle of incidence of  $35^\circ$  and that which is reflected by the slope 55 and incident from an opposite side similarly at an angle of incidence of  $35^\circ$ . Directions of incidence of these components match with directions which are perpendicular to two independent planes among four independent (111) planes in the crystal of a diamond structure. Namely, these two components define directions of two densest planes which are independent of each other, whereby it is possible to form a single-crystalline thin film of a diamond structure having a regulated crystal orientation so that the (110) planes are parallel to the substrate surface by employing the reflector 12d.

## (A-3. Third Preferred Embodiment)

A third preferred embodiment of the present invention is now described.

## (A-3-1. Overall Structure of Apparatus)

Fig. 13 is a front sectional view showing a structure of a single-crystalline thin film forming apparatus 100 for effectively implementing a method of forming a single-crystalline thin film according to a preferred

embodiment of the present invention. In Fig. 13, the identical numerals are employed with Fig. 4 to represent the identical components, and therefore, the detailed description of the numerals in Fig. 13 is omitted. Similarly to the apparatus 101, the apparatus 100 comprises a reaction vessel 1, and an electron cyclotron resonance (ECR) ion generator 2 which is built in an upper portion of the reaction vessel 1. In the interior of the reaction chamber 8, a sample holder 10 is arranged on a position immediately under the outlet 9. In this apparatus 101, the sample holder 10 is not required to comprise a heater. A substrate 11 is placed on the sample holder 10, while a reflector 12 is placed to be located above the substrate 11. The substrate 11, which is a flat plate of a material having a polycrystalline structure or an amorphous structure, is one of elements forming a sample. A desired single-crystalline thin film is formed on this substrate 11. The reflector 12a (Fig. 5, Figs. 6A to 6C), 12b (Fig. 9, Figs. 10A and 10B), 12c (Figs. 11A and 11B) or 12b (Figs. 12A and 12B) can be adopted as the reflector 12.

The reaction chamber 8 communicates with reaction gas supply pipes 13. Reaction gases are supplied through the reaction gas supply pipes 13, for forming a thin film of a prescribed material on the substrate 11 by plasma CVD. The preferred embodiment shown in Fig. 1 is provided with three reaction gas supply pipes 13a, 13b and 13c. Similarly to the apparatus 101, an end of the evacuation pipe 14 is coupled with a vacuum unit (not shown) to evacuate the reaction chamber 8 through the evacuation pipe 14, thereby maintaining the reaction chamber 8 at a prescribed degree of vacuum.

#### (A-3-2. Operation of Apparatus 100)

The operation of the apparatus 100 is now described. It is assumed that the reflector 12 is implemented by the reflector 12a shown in Figs. 5 and 6A to 6C and the substrate 11 is prepared from polycrystalline SiO<sub>2</sub> (quartz), so that a thin film of single-crystalline Si is formed on the quartz substrate 11. The reaction gas supply tubes 13a, 13b and 13c supply SiH<sub>4</sub> (silane) gas for supplying Si, which is a main material for the single-crystalline Si, and B<sub>2</sub>H<sub>6</sub> (diborane) gas and PH<sub>3</sub> (phosphine) gas for doping the substrate 11 with p-type and n-type impurities respectively. An inert gas which is introduced from the inert gas inlet pipe 7 is preferably prepared from Ne gas having a smaller atomic weight than Si atoms.

Due to the action of the ECR ion generator 2, a Ne<sup>+</sup> ion current and an electron stream are formed downwardly from the outlet 9. The distance between the outlet 9 and the reflector 12a (12) is preferably set at a sufficient level for substantially converting the Ne<sup>+</sup> ion current to a neutral Ne atom current. The reflector 12a (12) is set in a position receiving the downwardly directed Ne atom current. The silane gas which is supplied from the reaction gas supply tube 13a is dashed against the SiO<sub>2</sub> substrate 11 by the Ne<sup>+</sup> ion current or the Ne atom current. Consequently, a plasma CVD reaction progresses on the upper surface of the SiO<sub>2</sub> substrate 11, to grow a thin film formed by Si which is supplied by the silane gas, i.e., an Si thin film. On the other hand, the diborane gas or the phosphine gas is supplied with a properly adjusted flow rate, whereby a plasma CVD reaction caused by this gas also progresses to form the Si thin film containing B (boron) or P (phosphorus) in desired density.

The SiO<sub>2</sub> substrate 11 is not heated and hence maintained substantially at an ordinary temperature, whereby the Si thin film is grown substantially under the ordinary temperature. In other words, the Si thin film is formed at a temperature not more than a level facilitating crystallization by plasma CVD. Thus, the Si thin film is first formed as an amorphous Si film by plasma CVD.

A part of the downwardly directed Ne atom current is reflected by the three slopes 25 which are formed in the reflector 12a, to be incident upon the upper surface of the SiO<sub>2</sub> substrate 11 through the opening 24. Another part of the Ne atom current is not incident upon the slopes 25 but directly incident upon the upper surface of the SiO<sub>2</sub> substrate 11 through the opening 24. In other words, the Si thin film being formed on the upper surface of the SiO<sub>2</sub> substrate 11 is irradiated with four Ne atom current components, i.e., a component straightly received from the outlet 9 and three components reflected by the three slopes 25. Since the angles of inclination of the slopes 25 are set at 55°, directions of incidence of the four Ne atom current components correspond to four directions which are perpendicular to four independent densest crystal planes of the Si single crystal to be formed, i.e., (111) planes.

The energy of the plasma which is formed by the ECR ion generator 2 is so set that the Ne atoms reaching the SiO<sub>2</sub> substrate 11 are at energy levels causing no sputtering in the as-formed Si thin film, i.e., levels lower than the threshold energy level in sputtering of Si by irradiation with Ne atoms (= 27 eV). Therefore, the law of Bravais acts on the as-grown amorphous Si thin film. Namely, the Si atoms in the amorphous Si are rearranged so that planes which are perpendicular to the Ne atom current components applied to the amorphous Si define densest crystal planes. Since the Ne atom current as applied has four components which are incident in directions corresponding to those perpendicular to the densest planes of the single-crystalline Si having a single crystal orientation, the Si atoms are so rearranged that all planes

perpendicular to the directions of incidence of the respective components define the densest planes. The directions of the (111) planes are controlled by the plurality of components of the Ne atom current having directions of incidence which are independent of each other, whereby single-crystalline Si having a single crystal orientation is formed by such rearrangement of the Si atoms. In other words, the amorphous Si thin film being grown by plasma CVD is sequentially converted to a single-crystalline Si thin film having a regulated crystal orientation.

The diborane gas or the phosphine gas is supplied by the reaction gas supply pipe 13b or 13c simultaneously with the silane gas, thereby forming a p-type or n-type single-crystalline Si thin film containing B or P. It is also possible to form an equiaxed n-type single-crystalline Si layer on a p-type single-crystalline Si layer, for example, by alternating these reaction gases containing impurity elements.

As hereinabove described, the SiO<sub>2</sub> substrate 11 is not heated and the Si thin film is formed under a temperature which is lower than that facilitating crystallization by plasma CVD. This is because the crystal orientation is arbitrarily directed regardless of the directions of the Ne atom current components and cannot be controlled while a polycrystal is inevitably formed under a high temperature facilitating crystallization of Si by plasma CVD alone with no application of the Ne atom current components.

As described in the first preferred embodiment, Ne which is lighter than Si atoms is preferably selected as an element forming the atom current which is applied to the Si thin film. As described in the second preferred embodiment, the reflector 12 is preferably made of a metal.

In the apparatus 100, conversion to a single crystal sequentially progresses at the same time in the process of growth of the Si thin film by plasma CVD. Thus, it is possible to form a single-crystalline Si thin film having a large thickness under a low temperature. Since a single-crystalline thin film can be formed under a low temperature, it is possible to further form a new single-crystalline thin film on a substrate which is already provided with a prescribed device without changing properties of the device, for example.

Thus, it is possible to form a single-crystalline thin film not only on a substrate which serves only as a support member for a thin film but on a substrate of a device having a prescribed structure and functions in this apparatus 100.

An experimental test was performed in order to verify the formation of a single-crystalline thin film by the aforementioned method. A similar electron beam diffraction image to that shown in Fig. 8 was observed for a sample comprising polycrystalline SiO<sub>2</sub> substrates and single-crystalline Si thin films formed thereon.

This verifies that the sample obtained by use of the reflector 12 was formed as single-crystalline Si having regulated crystal axes. Since it was possible to form a single-crystalline Si thin film on an SiO<sub>2</sub> substrate of a polycrystalline structure having higher regularity than an amorphous structure in atomic arrangement, it is conceivably decided possible to form a single-crystalline thin film on a substrate having an amorphous structure, such as an amorphous Si substrate, as a matter of course.

#### (A-3-3. Preferred Methods of Forming Single-Crystalline Thin Films other than Si Thin Film)

While the structure and the operation of the apparatus 100 have been described with reference to formation of a single-crystalline thin film, it is also possible to form single-crystalline thin films other than an Si thin film through the apparatus 100. Tables 2 to 5 show conditions for forming semiconductor single-crystalline thin films having relatively high demands, including the Si thin film as already described, for example. Table 2 shows types of inert gases and reaction gases as supplied.

Tables 3 to 5 show reaction gas flow rates, inert gas flow rates and other process control conditions in formation of respective semiconductor single-crystalline thin films.



Table 2

Threshold Energy							
Target	Incident Ion (* Actually Measured Value)						
	He	Ne	Ar	Kr	Xe	Hg	Hg (Actually Measured Value)
Al	127	59	59	77	100	136	120 ~ 140
Si	60	27	27	35	45	61	60 ~ 70
GaAs			25*				
Ge	225	66	49	45	48	57	40 ~ 50
Ta	1620	385	233	233	159	147	120 ~ 140
W	1037	245	147	100	89	87	89 ~ 87
Pt	850	198	118	79	69	67	70 ~ 90

Table 3

Process Control Condition for Forming Si	
Gas Flow Rate	
SiH <sub>4</sub> or Si <sub>2</sub> H <sub>6</sub>	5sccm ( $1 \times 10^{-5} - 4 \times 10^{-5}$ mol/min)
AsH <sub>3</sub> (Diluted to 10% with Ne)	5sccm ( $5 \times 10^{-7}$ mol/min) for n-type Crystal
B <sub>2</sub> H <sub>6</sub> (Diluted to 10% with Ne)	5sccm ( $5 \times 10^{-7}$ mol/min) for p-type Crystal
Ne (for ECR Chamber)	25sccm ( $1 \times 10^{-3}$ mol/min)
Substrate Temperature (SiO <sub>2</sub> Substrate)	Room Temperature
Degree of Vacuum	
Back Pressure	$\sim 10^{-7}$ Torr
Operating Pressure	$1 \times 10^{-4} - 4 \times 10^{-4}$ Torr
Microwave Power (2.34 GHz)	300 W
Growth Rate	2 $\mu$ /hr

Table 4

Process Control Condition for Forming GaN	
Gas Flow rate	
TMG (Trimethyl Gallium) Carrier Gas N <sub>2</sub> NH <sub>3</sub> DMZ (Dimethyl Zinc) Carrier Gas N <sub>2</sub> SiH <sub>4</sub> (Diluted to 10% with Ne) Ne (For ECR Chamber)	Bubbler employed. Held at -12 °C ~ 10 °C 5sccm ( $1 \times 10^{-5} \sim 4 \times 10^{-5}$ mol/min) 10sccm ( $4 \times 10^{-4}$ mol/min) for Forming p-type Crystal 5sccm ( $1 \times 10^{-5} \sim 2.4 \times 10^{-5}$ mol/min) for Forming n-type Crystal 5sccm ( $1 \times 10^{-5} \sim 2.4 \times 10^{-5}$ mol/min) 15sccm ( $7 \times 10^{-4}$ mol/min)
Substrate Temperature (Si Substrate)	370 °C
Degree of Vacuum	
Back Pressure	$\sim 10^{-7}$ Torr
Operating Pressure	$1 \times 10^{-4} \sim 4 \times 10^{-4}$ Torr
Microwave Power (2.34 GHz)	300 W
Growth Rate	0.1 ~ 0.3 μ/hr

Table 5

Process Control Condition for Forming GaAs	
Gas Flow rate	
TMG (Trimethyl Gallium) Carrier Gas Ar AsH <sub>3</sub> (Diluted to 10% with Ar) DMZ (Dimethyl Zinc) Carrier Gas Ar H <sub>2</sub> Te (Diluted to 10% with Ar) Ar (For ECR Chamber)	Bubbler employed. Held at -12 °C ~ 10 °C 5sccm ( $1 \times 10^{-5} \sim 4 \times 10^{-5}$ mol/min) 10sccm ( $4 \times 10^{-4}$ mol/min) for Forming p-type Crystal 5sccm ( $1 \times 10^{-5} \sim 2.4 \times 10^{-5}$ mol/min) for Forming n-type Crystal 5sccm ( $1 \times 10^{-5} \sim 2.4 \times 10^{-5}$ mol/min) 15sccm ( $7 \times 10^{-4}$ mol/min)
Substrate Temperature (Si Substrate)	500 °C
Degree of Vacuum	
Back Pressure	$\sim 10^{-7}$ Torr
Operating Pressure	$1 \times 10^{-4} \sim 4 \times 10^{-4}$ Torr
Microwave Power (2.34 GHz)	300 W
Growth Rate	0.1 ~ 0.3 μ/hr

Thus, in each of the apparatuses 100 and 101, it is possible to form not only the aforementioned Si single-crystalline thin film but various types of single-crystalline thin films on substrates such as compound single-crystalline thin films of GaAs, GaN and the like and a single-crystalline thin film of an insulator such as SiO<sub>2</sub>, for example.

#### (A-4. Modifications of First to Third Preferred Embodiments)

(1) In the first or second preferred embodiment, in order to form single-crystalline thin film of GaN, for example, a polycrystalline GaN film may be first grown on an Si substrate by general CVD. Thereafter, by use of the apparatus 101, for example, N<sub>2</sub> (nitrogen) gas or NH<sub>3</sub> (ammonia) gas containing N atoms

may be introduced into the inert gas inlet pipe 7, to irradiate the GaN thin film with a molecular flow of the gas or a dissociated N atom current. N atoms which may remain in the interior of GaN are assembled into the single crystal as an element forming GaN, and hence there is no possibility of exerting a bad influence on properties of GaN.

5 (2) In the first or second preferred embodiment, in order to form a GaAs single-crystalline thin film, a GaAs polycrystalline thin film may be first grown on an Si substrate by general molecular beam epitaxy, so that conditions identical to those for forming an Si single-crystalline thin film are employed except that the substrate temperature is maintained at 500 °C, the gas as applied is prepared from low-priced Ar gas and the reflector is prepared from a Ta plate. It was possible to obtain a GaAs single-crystalline thin film  
10 by this method.

(3) In the third preferred embodiment, in order to form single-crystalline thin film of GaN, for example, N<sub>2</sub> (nitrogen) gas or NH<sub>3</sub> (ammonia) gas containing N atoms may be introduced into the inert gas inlet pipe 7 of the apparatus 100, to irradiate the GaN thin film with a molecular flow of the gas or a dissociated N atom current. Nitrogen which may remain in the interior of GaN is assembled into the single crystal as an  
15 element forming GaN, and hence there is no possibility of exerting a bad influence on properties of GaN.

(4) In place of the reflector 12, ECR ion generators 2 may be provided in a number corresponding to that of components of an atom current which is applied to the thin film, to directly apply the atom current from the ECR ion generators 2 to the thin film. As compared with this method, however, the method shown in Fig. 4 or Fig. 13 employing a single ECR ion generator 2 and a single reflector 12 is superior  
20 since the apparatus can be simplified in structure and it is possible to maintain a high degree of vacuum in the reaction chamber 8.

In the apparatus 100, further, the ECR ion generator 2 also serves as an energy source which is required for providing energy to the reaction gas for carrying out plasma CVD. Namely, the method shown in Fig. 13 employing a single ECR ion generator 2 and a single reflector 12 has a specific  
25 advantage such that the same can be carried out by simply adding the reflector 12 to a structure which is originally necessary for carrying out plasma CVD.

(5) The ECR ion generator 2 may be replaced by another ion source such as a Cage type or Kaufmann type one. In this case, however, flow of the as-formed ion current is inclined to be diffused by repulsion caused by static electricity between ions, leading to reduction of directivity. Therefore, it is desirable to provide means for neutralizing ions and converting the same to an atom current or means for improving the directivity such as a collimator in a path of the ion current. When an electrical insulating substrate is employed as the substrate 11, in particular, it is desirable to provide the means for neutralizing ions in order to prevent the progress of irradiation from being disabled due to storage of charges in the substrate 11. Alternatively, the reflector 12 may be made of a conductive material such as a metal, to simultaneously carry out reflection of the ion current and conversion to a neutral atom current.  
35

In the aforementioned method employing the ECR ion generator 2, on the other hand, a neutral atom current can be easily obtained in a form close to a parallel current with no employment of means for neutralizing the ion current. Therefore, the thin film can be easily irradiated with an atom current having high incidence angle accuracy. Since a neutral atom current is mainly incident upon the thin film, further, the substrate 11 can be prepared from an insulating substrate such as an SiO<sub>2</sub> substrate.  
40

#### (A-5. Fourth Preferred embodiment)

Next, an apparatus according to a fourth preferred embodiment of the present invention is described.

45 Fig. 14 is a front sectional view showing the overall structure of an axially oriented polycrystalline thin film forming apparatus 122 according to the fourth preferred embodiment. This apparatus 122 is adapted to grow a thin film of a prescribed material on a substrate and to simultaneously convert the thin film to a uniaxially oriented polycrystalline thin film, thereby forming an axially oriented polycrystalline thin film on the substrate. This apparatus 122 is characteristically different from the apparatus 100 shown in Fig. 13 in that a reflector 12 is not provided therein.  
50

Referring to Fig. 14, the operation of the apparatus 122 is now described. It is assumed that the substrate 11 is prepared from polycrystalline SiO<sub>2</sub> (quartz), so that a thin film of single-crystalline Si is formed on the quartz substrate 11. The reaction gas supply tubes 13a, 13b and 13c supply SiH<sub>4</sub> (silane) gas for supplying Si, which is a main material for the single-crystalline Si, and B<sub>2</sub>H<sub>3</sub> (diborane) gas and PH<sub>3</sub> (phosphine) gas for doping the substrate 11 with p-type and n-type impurities respectively. The inert gas  
55 introduced from the inert gas inlet pipe 7 is preferably prepared from Ne gas, which has smaller atomic weight than Si atoms and is inert gas.

Due to the action of the ECR ion generator 2, an  $\text{Ne}^+$  ion current and an electron current are formed downwardly from the outlet 9. The distance between the outlet 9 and the substrate 11 is preferably set at a value which is sufficient for converting most part of the  $\text{Ne}^+$  ion current to a neutral Ne atom current. The silane gas which is supplied from the reaction gas supply tube 13a is dashed against the substrate 11 by the  $\text{Ne}^+$  ion current or the Ne atom current. Consequently, a plasma CVD reaction progresses on the upper surface of the substrate 11, to grow a thin film formed by Si which is supplied by the silane gas, i.e., an Si thin film. On the other hand, the diborane gas or the phosphine gas is supplied with a properly adjusted flow rate, whereby a plasma CVD reaction caused by this gas also progresses to form the Si thin film containing B (boron) or P (phosphorus) in desired density.

The substrate 11 is not heated and hence maintained substantially at an ordinary temperature. Therefore, the Si thin film is grown substantially under the ordinary temperature. In other words, the Si thin film is formed at a temperature not more than a level facilitating crystallization by plasma CVD. Thus, the Si thin film is first formed as an amorphous Si film by plasma CVD.

The aforementioned downwardly directed Ne atom current is perpendicularly incident upon the upper surface of the substrate 11. Namely, the Si thin film being formed on the upper surface of the substrate 11 is irradiated with the Ne atom current which is linearly discharged from the outlet 9.

The energy of the plasma which is formed by the ECR ion source 2 is so set that the energy of Ne atoms reaching the substrate 11 is at a value causing no sputtering in the Si thin film, i.e., lower than the threshold energy (= 27 eV) in sputtering of Si by irradiation with Ne atoms. Therefore, the so-called law of Bravais acts on the amorphous Si thin film as being grown. Namely, the Si atoms in the amorphous Si are rearranged so that a plane which is perpendicular to the direction of incidence of the Ne atom current applied to the amorphous Si defines the densest crystal plane, i.e., the (111) plane.

In other words, the amorphous Si thin film being grown by plasma CVD is sequentially converted to a polycrystalline Si thin film in which directions of crystal axes perpendicular to a single densest plane are regulated in a direction perpendicular to the surface of the substrate 11, i.e., a uniaxially oriented polycrystalline crystalline Si thin film. Consequently, a polycrystalline Si thin film is formed on the substrate 11, so that a (111) plane is exposed on the surface of any crystal grain forming this polycrystalline structure.

The diborane gas or the phosphine gas is supplied by the reaction gas supply pipe 13b or 13c simultaneously with the silane gas, thereby forming a p-type or n-type uniaxially oriented polycrystalline Si thin film containing B or P.

In the apparatus 122, portions which may be irradiated with the Ne atom current or the Ne ion current before neutralization, such as the inner wall of the reaction vessel 1 and the upper surface of the sample holder 10, for example, are made of materials causing no sputtering by the irradiation. In other words, the same are made of materials having higher threshold energy values than the energy of the Ne ion current. Therefore, no sputtering is caused in these members by irradiation with the Ne atom current or the Ne ion current, whereby the thin film is prevented from contamination with material elements forming these members. Further, these members are prevented from damage caused by sputtering.

Since the energy of the Ne ion current is set to be lower than the threshold energy in the Si thin film to be formed, the reaction vessel 1, the sample holder 10 and the like may be made of materials, such as Ta, W, Pt and the like shown in Table 2, for example, having threshold energy values which are higher than that of the Si thin film in Ne irradiation. Alternatively, the surfaces of these members, such as the inner wall of the reaction vessel 1 and the surface of the sample holder 10, for example, may be coated with materials such as Ta having high threshold energy, to obtain a similar effect.

While the structure and the operation of the apparatus 122 have been described with reference to formation of an Si thin film, it is also possible to form an axially oriented polycrystalline thin film of a material other than Si. For example, it is also possible to form a GaAs thin film. In this case, reaction gases supplied from the reaction gas supply pipes 13a, 13b and 13c are prepared from reaction gases containing  $\text{Ga}(\text{CH}_3)_3$  etc., which are suitable for formation of GaAs. While GaAs is a compound consisting of two elements, an element for forming the ion current or the atom current as applied may be prepared from an element such as Ne or Ar, for example, which is lighter than As having larger atomic weight in these two elements. The irradiation energy is similarly set to be lower than the threshold energy which is related to As having large atomic weight.

When the thin film to be formed is made of a plurality of elements, the element forming the ion current or the atom current as applied may be prepared from that which is lighter than that having the maximum atomic weight among the plurality of elements, in general. The irradiation energy is similarly set to be lower than threshold energy which is related to the element having the maximum atomic weight. In this case, the surface of the member such as the sample holder 10 which is irradiated with the ion current or the atom

current in the apparatus 122 may be made of a material having higher threshold energy than the material for the thin film.

Alternatively, the surface may be made of the same material as the thin film. When the apparatus 122 is structured as that for forming an axially oriented polycrystalline thin film of Si, for example, the surface of the sample holder 10 etc. may be coated with Si. In this case, no contamination of the Si thin film is caused by a different element even if sputtering is caused in the sample holder 10 or the like.

Further, the surface of the member such as the sample holder 10 which is irradiated with the ion current or the atom current may be made of a material containing an element which is heavier than that forming the ion current or the atom current as applied. In this case, the element forming the ion current or the atom current hardly penetrates into the member following application of the ion current or the atom current. Thus, deterioration of the member caused by penetration of a different element is suppressed.

In the apparatus 122, conversion to a uniaxially oriented polycrystalline film sequentially progresses simultaneously with growth of the Si thin film by plasma CVD. Thus, it is possible to form an axially oriented polycrystalline Si thin film having a large film thickness under a low temperature. Since the axially oriented polycrystalline thin film can be formed under a low temperature, it is possible to form a uniaxially oriented crystalline thin film on a substrate which is already integrated with a prescribed device, for example, without changing characteristics of this device.

In the above description, the substrate 11 is horizontally placed on the sample holder 10, whereby the atom current is perpendicularly incident upon the substrate 11. When an axially oriented polycrystalline thin film of Si, for example, is formed on the substrate 11, therefore, the surface of the thin film is defined by a (111) plane. However, it is also possible to form an axially oriented polycrystalline thin film of Si in which (111) planes are uniformly oriented in a desired direction which is inclined with respect to the surface of the thin film, by placing the substrate 11 on the sample holder 10 in an inclined manner.

The sample holder 10 may be coupled to a rotary mechanism or the like, to be capable of horizontally rotating the substrate 11. Alternatively, the sample holder 10 may be coupled to a horizontal moving mechanism or the like, to be capable of horizontally moving the substrate 11. Thus, it is possible to uniformly form a uniaxially oriented thin film on the substrate 11.

#### (A-1-4. Valid Data)

Description is now made on a test verifying formation of an axially oriented polycrystalline thin film by the aforementioned method. Fig. 15 illustrates experimental data showing an electron beam diffraction image of a sample comprising an axially oriented polycrystalline Si thin film formed on a polycrystalline quartz substrate 11 on the basis of the aforementioned method. In this verification test, the surface of the substrate 11 was perpendicularly irradiated with an Ne atom current.

As shown in Fig. 15, a diffraction spot appears on a single point, and is continuously distributed along a circumference around the same. Namely, the result of the experiment indicates that a single (111) plane of the Si thin film as formed is oriented to be perpendicular to the direction of incidence of the atom current, while orientation around the direction of incidence is arbitrary and not regulated in one direction. Namely, it is verified that this sample is formed as polycrystalline Si in which only a single crystal axis is regulated, i.e., as axially oriented polycrystalline Si.

Since it was possible to form an axially oriented polycrystalline Si thin film on the quartz substrate 11 having a polycrystalline structure which is higher in regularity in atom arrangement than an amorphous structure, it can be decided possible to form an axially oriented polycrystalline thin film on a substrate having an amorphous structure of amorphous Si or the like, as a matter of course. It can also be decided possible to form an axially oriented polycrystalline thin film on a substrate having a single-crystalline structure which is equivalent to a structure obtained by enlarging polycrystal grains, similarly to the above.

#### (A-6. Fifth Preferred embodiment)

A fifth preferred embodiment of the present invention is now described.

##### (A-6-1. Overall Structure of Apparatus)

Fig. 16 is a front sectional view showing the overall structure of an apparatus 120 according to the fifth preferred embodiment. This apparatus 120 is, similarly to the apparatus 100 shown in Fig. 13, an apparatus for forming single-crystalline thin film which is adapted to grow a thin film of a prescribed material on a substrate and to simultaneously convert the thin film to a single-crystalline thin film, thereby forming a

single-crystalline thin film on the substrate. This apparatus 120 is characteristically different from the apparatus 100 shown in Fig. 13 in structure of the reflector 12. Furthermore, each part of the apparatus 103 is composed of specific materials, as described later.

The reflector 12e is adapted to reflect an atom current which is supplied from an ECR ion source 2, thereby irradiating a substrate 11 with the atom current from a plurality of directions. Therefore, the reflector 12e is set to be located immediately under an outlet 9 above the substrate 11.

#### (A-6-2. Structure and Function of Reflector)

Fig. 17 is a perspective view showing a preferable example of the reflector 12e. Fig. 18 is a plan view of the reflector 12e shown in Fig. 17, and Figs. 19 and 20 are exploded views. With reference to these figures, the example of the reflector 12e is now described.

This reflector 12e is an exemplary reflector for forming a single crystal such as single-crystalline Si, having a diamond structure. The reflector 12e defines an equilateral hexagonal opening in a central portion of a flat plate type screen plate 151. Three reflecting blocks 153 are fixedly provided on a lower surface of the screen plate 151, to enclose the opening. These reflecting blocks 153 are fastened to the screen plate 151 by screws passing through holes 157 to be fitted with screw holes 158. Consequently, an equilateral triangular opening 154 which is trimmed with these reflecting blocks 153 is defined immediately under the opening of the screen plate 151.

The atom current which is applied from above is selectively screened by the screen plate 151, to pass only through the equilateral hexagonal opening. In the reflecting blocks 153, slopes 154 facing the opening 154 serve as reflecting surfaces for reflecting the gas beam. As shown in Fig. 18 in a plan view, the three slopes 155 are selectively exposed on the equilateral hexagonal opening of the screen plate 151 respectively. Therefore, the atom current which is applied from above is divided into four components in total including a first component passing through the opening 154 to be directly perpendicularly incident upon the substrate 11 and second to fourth components reflected by the three slopes 155 respectively to be incident upon the substrate 11 from oblique directions.

As shown in Fig. 18, each of three corners of the equilateral triangular opening 154 coincides with every other corner of the equilateral hexagonal opening, as viewed from above. In other words, the three slopes 155 are selectively exposed on three isosceles triangles having adjacent pairs of sides of the equilateral hexagonal opening as isosceles sides. This prevents multiple reflection by the plurality of slopes 155, while enabling uniform irradiation of the substrate 11 with the respective atom current components. This is now described with reference to Figs. 21 and 22.

Fig. 21 is a plan view of the reflector 12e, which is similar to Fig. 18. Fig. 22 is a sectional view taken along the line A - A in Fig. 21. As shown in Figs. 21 and 22, an atom current which is incident upon a position (B in the figures) on one slope 155 corresponding to the apex of the equilateral triangle is reflected and then incident upon an opposite apex (C in the figures) of the equilateral triangular opening 154. Assuming that D represents an intersection between one side of the opening 154 and the line A - A, an atom current which is applied across the points B and D on the slope 155 is uniformly distributed across the points D and C of the opening 154.

This also applies to an atom current which is applied onto an arbitrary line E - E deviating in parallel with the line A - A. Namely, the atom current which is discharged from the outlet 9 is selectively supplied onto the slopes 155 by the screen plate 151, whereby as-reflected atom currents of three components are uniformly incident upon a region of the substrate 11 which is located immediately under the opening 154.

Each atom current which is supplied to one slope 155 through the equilateral hexagonal opening is entirely incident upon the opening 154, and is not incident upon the adjacent slope 155. Thus, no components multiplexly reflected by the plurality of slopes 155 are incident upon the substrate 11.

The angle of inclination of each slope 155 is set at 55°, for example, as shown in Fig. 22. The atom current which is reflected by each slope 155 is incident upon the substrate 11 which is located immediately under the opening 154 at an angle of incidence of 70°. Namely, the first component is perpendicularly incident upon the substrate 11, while the second to fourth components are incident upon the same at angles of incidence of 70° in directions which are three-fold symmetrical about the direction of incidence of the first component. At this time, the directions of incidence of the first to fourth components correspond to four directions which are perpendicular to four (111) planes, being densest planes of the Si single crystal.

55

## (A-6-3. Operation of Apparatus)

Referring again to Fig. 16, the operation of the apparatus 120 is now described. It is assumed that the reflector 12e is prepared from that shown in Figs. 17 to 20, and the substrate 11 is prepared from polycrystalline SiO<sub>2</sub> (quartz), so that a thin film of single-crystalline Si is formed on the quartz substrate 11. It is also assumed that the slopes 155 in the reflector 12e are set at 55°.

Reaction gas supply pipes 13a, 13b and 13c supply SiH<sub>4</sub> (silane) gas for supplying Si, which is a main material for the single-crystalline Si, and B<sub>2</sub>H<sub>6</sub> (diborane) gas and PH<sub>3</sub> (phosphine) gas for doping the substrate 11 with p-type and n-type impurities respectively. Inert gas which is introduced from an inert gas inlet pipe 7 is preferably prepared from Ne gas, which has smaller atomic weight than Si atoms.

Due to the action of an ECR ion generator 2, an Ne<sup>+</sup> ion current and an electron current are formed downwardly from the outlet 9. The distance between the outlet 9 and the reflector 12e is preferably set at a value sufficient for converting most part of the Ne<sup>+</sup> ion current to a neutral Ne atom current.

Thus, a plasma CVD reaction progresses on the upper surface of the substrate 11 similarly to the apparatus 122 shown in Fig. 13, to grow an amorphous Si thin film. On the other hand, the diborane gas or the phosphine gas is supplied with a properly adjusted flow rate, whereby a plasma CVD reaction caused by this gas also progresses to form the Si thin film containing B (boron) or P (phosphorus) in desired density.

At the same time, the amorphous Si thin film which is being formed on the substrate 11 is irradiated with the four components of the Ne atom current, by the action of the reflector 12e. As hereinabove described, directions of incidence of these four components correspond to directions which are perpendicular to four (111) planes of an Si single crystal. Similarly to the apparatus 122, further, the energy of plasma which is formed by the ECR ion source 2 is so set that the energy of Ne atoms reaching the substrate 11 is at a value causing no sputtering in the Si thin film, i.e., lower than the threshold energy (= 27 eV) in sputtering of Si by irradiation with Ne atoms. Therefore, the amorphous Si thin film being grown by plasma CVD is sequentially converted to a single-crystalline Si thin film having a regulated crystal orientation, similarly to the apparatus 100. Consequently, a single-crystalline Si thin film having a regulated crystal orientation is finally formed on the substrate 11. This single-crystalline Si thin film has a (111) plane on its surface.

In the apparatus 120, due to employment of the reflector 12e, no multiple reflection of the atom current is caused by the plurality of slopes 155. Thus, the substrate 11 is irradiated with no atom current from a direction other than the prescribed four directions. Further, the reflector 12e implements uniform irradiation of the substrate 11 with the atom current, whereby the substrate 11 is uniformly irradiated with the atom current from the prescribed four directions. Thus, the single-crystalline Si thin film is uniformly formed on the substrate 11.

In the apparatus 120, portions which may be irradiated with the Ne atom current or an Ne ion current before neutralization, such as the reflector 12e, the inner wall of the reaction vessel 1 and the sample holder 10, for example, are made of materials causing no sputtering by the irradiation, i.e., materials having higher threshold energy values than the energy of the Ne ion current, such as Ta, W, Pt or the like shown in Table 2, for example. Therefore, no sputtering is caused in these members by irradiation with the Ne atom current or the Ne ion current, whereby the thin film is prevented from contamination with material elements forming these members.

Alternatively, surfaces of the members irradiated with the Ne atom current such as the upper surface of the screen plate 151 and the slopes 155 may be coated with materials such as Ta having high threshold energy, to attain a similar effect.

While the structure and the operation of the apparatus 120 have been described with reference to formation of an Si thin film, it is also possible to form an axially oriented polycrystalline thin film of a material other than Si. For example, it is also possible to form a GaAs thin film. It is possible to form a single-crystalline thin film of an arbitrary material having a desired crystal structure and a desired crystal orientation by properly changing the structure of the reflector 12e such as the angles of inclination and the number of the slopes 155. The surface of the reflector 12e etc. is made of a material having higher threshold energy than that of the thin film.

Alternatively, the surface of the reflector 12e etc. may be made of the same material as that for the thin film. When the apparatus 120 is structured as an apparatus for forming a single-crystalline thin film of Si, for example, the surface of the reflector 12e etc. may be coated with Si. In this case, no contamination of the Si thin film is caused by a different element even if sputtering is caused in the reflector 12e or the like.

Further, the surface of the reflector 12e etc. may be made of a material containing an element which is heavier than that forming the ion current or the atom current as applied. Thus, the element forming the ion

current or the atom current hardly penetrates into the members following irradiation with the ion current or the atom current. Thus, these members are inhibited from deterioration caused by penetration of the different element.

5 (A-7. Sixth Preferred Embodiment)

An apparatus according to a sixth preferred embodiment of the present invention is now described. Figure 13 is a front sectional view showing the overall structure of the apparatus 121 according to this preferred embodiment. This apparatus 121 is, similarly to the apparatus 101 shown in Fig. 4, a single-crystalline thin film forming apparatus, which is adapted to previously form a thin film of a prescribed material having an amorphous or polycrystalline structure on a substrate and to thereafter convert the thin film to a single-crystalline thin film, thereby forming a single-crystalline thin film on the substrate.

This apparatus 121 is characteristically different from the apparatus 101 in structure of the reflector 12e. Furthermore, each part of the apparatus 121 is composed specific materials, as described later. A sample holder 10, which comprises a heater (not shown), can heat a substrate 11 to hold the same at a proper high temperature.

Referring to Fig. 23, the basic operation of the apparatus 121 is now described. It is assumed that a reflector 12e is implemented by that shown in Figs. 17 to 20 and the substrate 11 is prepared from a polycrystalline quartz substrate, so that a single-crystalline Si thin film is formed on the quartz substrate 11. It is also assumed that a polycrystalline Si thin film is previously formed on the quartz substrate 11 by a well-known method such as CVD (chemical vapor deposition).

First, the substrate 11 is mounted between the sample holder 10 and the reflector 12e. The heater provided in the sample holder 10 holds the substrate 11 at a temperature of 550 °C. Since this temperature is lower than the crystallization temperature of silicon, single-crystalline Si once formed will not return to polycrystalline Si under this temperature. At the same time, this temperature is so high that polycrystalline Si can be grown into single-crystalline Si from a nucleus of a seed crystal.

For the same reason as that described in relation to the fourth preferred embodiment, an Ne atom current is selected as an atom current to be applied to the substrate 11, and energy of Ne plasma which is formed by an ECR ion source 2 is so set that energy of Ne atoms reaching the substrate 11 is lower than threshold energy in sputtering of Si. Further, the polycrystalline Si thin film which is formed on the substrate 11 is irradiated with four components of the Ne atom current by the action of the reflector 12e. Directions of incidence of these four components correspond to those perpendicular to four (111) planes of the Si single crystal.

Therefore, the overall region of the polycrystalline Si thin film is converted to a single-crystalline Si layer similarly to the apparatus 101. Thus, a single-crystalline Si layer having a regulated crystal orientation is formed on the quartz substrate 11.

In the apparatus 121, due to employment of the reflector 12e, no multiple reflection of the atom current is caused by the plurality of slopes 155. Thus, the substrate 11 is irradiated with no atom current from a direction other than the prescribed four directions. Further, the reflector 12e implements uniform irradiation of the substrate 11 with the atom current, whereby the substrate 11 is uniformly irradiated with the atom current from the prescribed four directions. Thus, the single-crystalline Si thin film is uniformly formed on the substrate 11.

Similarly to the apparatus 120, portions which may be irradiated with the Ne atom current or an Ne ion current before neutralization, such as the reflector 12e, the inner wall of a reaction vessel 1 and the sample holder 10, for example, are made of materials causing no sputtering by the irradiation such as Ta, W, Pt or the like shown in Table 2, for example, also in the apparatus 121. Therefore, no sputtering is caused in these members by irradiation with the Ne atom current or the Ne ion current, whereby the thin film is prevented from contamination with material elements forming these members.

While the structure and the operation of the apparatus 121 have been described with reference to formation of an Si thin film, it is also possible to form an axially oriented polycrystalline thin film of a material other than Si with the apparatus 121. For example, it is also possible to form a GaAs thin film. Also in this case, the surface of the reflector 12e etc. is made of a material having higher threshold energy than that forming the thin film. Alternatively, the surface of the reflector 12e etc. may be made of the same material as that for the thin film, similarly to the apparatus 120. Further, the surface of the reflector 12e etc. may be made of a material containing an element which is heavier than that forming the ion current or the atom current as applied.



## (A-8. Seventh Preferred Embodiment)

An apparatus according to a seventh preferred embodiment of the present invention is now described. Fig. 24 is a front sectional view showing the overall structure of the apparatus 123 according to this preferred embodiment. This apparatus 123 is an axially oriented polycrystalline thin film forming apparatus which is adapted to previously form a thin film of a prescribed material having an amorphous or polycrystalline structure on a substrate and to thereafter convert the thin film to an axially oriented polycrystalline thin film, thereby forming an axially oriented polycrystalline thin film on the substrate.

As shown in Fig. 24, this apparatus 123 has such a structure that the reflector 12e is removed from the apparatus 121 (Fig. 23). Similarly to the apparatus 121, a sample holder 10 comprises a heater (not shown), which can heat a substrate 11 to hold the same at a proper high temperature.

Referring to Fig. 24, the basic operation of the apparatus 123 is now described. It is assumed that the substrate 11 is prepared from a polycrystalline quartz substrate, so that an axially oriented polycrystalline Si thin film is formed on the quartz substrate 11. It is also assumed that a polycrystalline Si thin film is previously formed on the quartz substrate 11 by a well-known method such as CVD (chemical vapor deposition). This polycrystalline Si thin film may have such an ordinary polycrystalline structure that respective crystal grains are oriented in arbitrary directions.

First, the substrate 11 is mounted on the sample holder 10. The heater provided in the sample holder 10 holds the substrate 11 at a temperature of 550 °C. Since this temperature is lower than the crystallization temperature of silicon, axially oriented polycrystalline Si once formed will not return to ordinary polycrystalline Si under this temperature. At the same time, this temperature is so high that ordinary polycrystalline Si can be grown into axially oriented polycrystalline Si from a nuclear of a seed crystal.

An ion current passing through an outlet 9 is converted to an atom current, which in turn is perpendicularly incident upon the surface of the substrate 11. For the same reason as that described in relation to the seventh preferred embodiment, an Ne atom current is selected as the atom current to be applied to the substrate 11, and energy of Ne plasma which is formed by an ECR ion source 2 is so set that energy of Ne atoms reaching the substrate 11 is lower than threshold energy in sputtering of Si.

Thus, the law of Bravais acts in a portion close to the surface of the polycrystalline Si thin film, whereby the Si atoms are rearranged in a portion close to the surface of the polycrystalline Si thin film so that a surface perpendicular to the direction of incidence of the Ne atom current which is applied to the polycrystalline Si thin film defines the densest crystal plane. Namely, a layer close to the surface of the polycrystalline Si thin film is converted to an axially oriented polycrystalline Si layer whose uniaxial direction is regulated so that the (111) plane is along its surface.

The temperature of the polycrystalline Si thin film is adjusted at 550 °, i.e., within a range suitable for growing a seed crystal, as described above. Thus, the axially oriented polycrystalline Si layer which is formed on the surface of the ordinary polycrystalline Si thin film serves as a seed crystal, to grow the axially oriented polycrystalline Si layer toward a deep portion of the ordinary polycrystalline Si thin film. Then, the overall region of the polycrystalline Si thin film is converted to an axially oriented polycrystalline Si layer. Thus, an axially oriented polycrystalline Si layer which is so oriented that the (111) plane is along its surface is formed on the quartz substrate 11.

Alternatively, an amorphous Si thin film may be previously formed on the substrate 11 in place of the ordinary polycrystalline Si thin film to be thereafter treated with the apparatus 123, thereby forming an axially oriented polycrystalline Si thin film.

Also in the apparatus 123, portions which may be irradiated with the Ne atom current or an Ne ion current before neutralization, such as at least surfaces of the inner wall of a reaction vessel 1 and the sample holder 10, for example, are made of materials causing no sputtering by the irradiation, such as Ta, W, Pt or the like shown in Table 2, for example, similarly to the apparatus 122. Therefore, no sputtering is caused in these members by irradiation with the Ne atom current or the Ne ion current, whereby the thin film is prevented from contamination with material elements forming these members.

While the structure and the operation of the apparatus 123 have been described with reference to formation of an Si thin film, it is also possible to form an axially oriented polycrystalline thin film of a material other than Si by the apparatus 123. For example, it is also possible to form a GaAs thin film. Also in this case, the surface of the sample holder 10 etc. is made of a material having higher threshold energy than that of the thin film. Alternatively, the surface of the sample holder 10 etc. may be made of the same material as that for the thin film, similarly to the apparatus 122. Further, the surface of the sample holder 10 etc. may be made of a material containing an element which is heavier than that forming the ion current or the atom current as applied.

## (A-9. Eighth Preferred Embodiment)

An eighth preferred embodiment of the present invention is now described. A method according to this preferred embodiment is adapted to form an axially oriented polycrystalline thin film on a substrate 11 and to thereafter convert the same to a single-crystalline thin film by irradiating the film with atom currents from a plurality of directions, thereby forming a single-crystalline thin film on the substrate 11. To this end, the apparatus 122 according to the fourth preferred embodiment may be employed to form an axially oriented polycrystalline thin film on the substrate 11, so that this thin film is converted to a single-crystalline thin film through the apparatus 121 according to the seventh preferred embodiment, for example.

Alternatively, the apparatus 120 according to the eighth preferred embodiment may be employed to form an axially oriented polycrystalline thin film by executing supply of reaction gas and application of an atom current at first while removing the reflector 12e, so that the reflector 12e is thereafter set in the apparatus 120 to execute application of an atom current while heating the substrate 11 for converting the thin film to a single-crystalline thin film, thereby forming a single-crystalline thin film on the substrate 11.

Alternatively, a thin film having an amorphous structure or an ordinary polycrystalline structure may be previously formed on the substrate 11 by CVD or the like so that the thin film is thereafter converted to an axially oriented polycrystalline thin film through the apparatus 123 and thereafter the film is further converted to a single-crystalline thin film through the apparatus 121, thereby forming a single-crystalline thin film on the substrate 11.

Thus, in the method according to this preferred embodiment, an axially oriented polycrystalline thin film is previously formed before a single-crystalline thin film is formed on the substrate 11. Even if a portion which is hard to form a single-crystalline thin film is present on the substrate 11, therefore, mechanical and electrical properties of the thin film are not remarkably deteriorated since the portion is provided with an axially oriented polycrystalline thin film having characteristics which are close to those of a single-crystalline thin film. Namely, it is possible to obtain a thin film having properly excellent characteristics without precisely executing a step of forming a single-crystalline thin film.

This is particularly effective when it is difficult to uniformly irradiate a prescribed region of the substrate 11 with atom currents from a plurality of directions since the substrate 11 is not in the form of a flat plate but is in the form of a cube, or a screen having a thickness is formed on the surface of the substrate 11. Figs. 25 to 27 show such examples.

Fig. 25 is a sectional view typically illustrating such a state that the surface of a sample 170 comprising a substrate 11 having a cubic shape and an axially oriented polycrystalline Si thin film 171 previously formed thereon is irradiated with Ne atom currents from two directions. As shown in Fig. 25, the sample 170 has a cubic shape and hence the sample 170 itself serves as a screen for the atom currents. Consequently, a specific region of the axially oriented polycrystalline Si thin film 171 is irradiated with the Ne atom current from only one direction, and no irradiation from two directions is implemented.

Figs. 26 and 27 are sectional views typically showing steps of selectively forming a single-crystalline Si thin film on a substrate 11 through a masking member 172 in a process of fabricating a thin-film semiconductor integrated circuit. An amorphous or ordinary polycrystalline Si thin film 174 is previously formed on the substrate 11 by CVD or the like. Thereafter the apparatus 123 is employed to perpendicularly irradiate the upper surface of the Si thin film 174 with an Ne atom current through an opening of the masking member 172 which is made of SiO<sub>2</sub> or the like, thereby selectively forming an axially oriented polycrystalline Si thin film 171 immediately under the opening of the masking member 172 (Fig. 26).

Then, the apparatus 121 is employed to irradiate the upper surface of the Si thin film 171 with Ne atom currents from a plurality of directions through the opening of the masking member 172, thereby converting the axially oriented polycrystalline Si thin film 171 to a single-crystalline Si thin film (Fig. 27). At this time, a portion close to an edge of the opening of the masking member 172 is not sufficiently irradiated with the Ne atom currents from the plurality of directions since the masking member 172 has a constant thickness. Thus, the single-crystalline Si thin film is hardly formed in the portion close to the edge of the opening of the masking member 172. However, at least the axially oriented polycrystalline Si thin film is provided in this portion even if no single-crystalline Si thin film is formed, whereby it is possible to minimize deterioration of electrical properties such as carrier mobility.

In the method according to this preferred embodiment, one of the plurality of directions of incidence of the atom currents which are applied to carry out conversion to a single-crystalline thin film is preferably coincident with the direction of incidence of the atom current which is applied in advance for forming the axially oriented polycrystalline thin film. In this case, conversion to a single-crystalline thin film is carried out without changing the common uniaxial direction in the axially oriented polycrystalline thin film, whereby the step of conversion to a single-crystalline thin film smoothly progresses in a short time.

## (A-10. Ninth Preferred Embodiment)

A ninth preferred embodiment of the present invention is now described.

## 5 (A-10-1. Structure of Apparatus)

Fig. 28 is a front sectional view showing the overall structure of an apparatus 124 according to this preferred embodiment. This apparatus 124 is adapted to convert an amorphous, polycrystalline, or axially oriented polycrystalline thin film which is previously formed on a substrate 11 to a single-crystalline thin film, thereby forming a single-crystalline thin film on the substrate 11.

This apparatus 124 is characteristically different from the apparatus 121 in a point that a reflecting unit 160 is set in place of the reflector 12e. The reflecting unit 160, which is adapted to generate a plurality of atom current components to be incident upon the substrate 11 at a plurality of prescribed angles of incidence, is set on a sample holder 10, to be located above the substrate 11. The sample holder 10 comprises a heater (not shown), which can heat the substrate 11 to maintain the same at a proper high temperature.

## (A-10-2. Structure and Operation of Reflecting Unit)

The structure and the operation of the reflecting unit 160 are now described. Figs. 29 and 30 are a front sectional view and a plan sectional view showing the structure of the reflecting unit 160 respectively. The reflecting unit 160 illustrated in Figs. 29 and 30 is adapted to form a single crystal of a diamond structure such as single-crystalline Si. This reflecting unit 160 is arranged directly under an ion outlet 9 of an ECR ion source 2, i.e., downstream an atom current which is generated by the ECR ion source 2 to be downwardly directed.

A screen plate 164 which can selectively screen the atom current supplied from the ECR ion source 2 is horizontally provided on an upper portion of the reflecting unit 160. The reflecting unit 160 is so set that a distance between the outlet 9 and this screen plate 164 is at a sufficient value, such as at least 14 cm, for example, for converting an ion current outputted from the ECR ion source 2 to a neutral atom current. Namely, a substantially neutral atom current reaches the screen plate 164. Openings 162 are provided in this screen plate 164, to be in four-fold rotation symmetry about a central axis of the atom current from the ECR ion source 2. The atom current from the ECR ion source 2 passes only through the openings 162, to further flow downwardly.

A reflecting block 166 is set immediately under this screen plate 164. This reflecting block 166 is in the form of a four-fold rotary-symmetrical cone whose symmetry axis is coincident with the central axis of the atom current, and four side surfaces of the cone are located immediately under the four openings 162 respectively. These side surfaces are not necessarily plane, but are curved in general. These four side surfaces serve as reflecting surfaces for reflecting the atom current. Namely, the atom current passing through the openings 162 is reflected by the four side surfaces of the reflecting block 166, whereby four atom current components progressing toward directions separated from the central axis are obtained.

These four atom current components are divergent beams whose beam sections are two-dimensionally (planarly) enlarged. These four components pass through a rectifying member (rectifying means) 168 so that directions of progress thereof are accurately regulated in desired directions, to be thereafter incident upon four reflectors 169 respectively. The rectifying member 168, which is adapted to regulate the directions of the atom current components radially from the side surfaces of the reflecting block 166 toward the reflecting plates 169, can be formed by a well-known technique.

These four reflectors 169 are arranged around the substrate 11, which is the target of irradiation, to be four-fold rotation symmetrical about the symmetry axis of the reflecting block 166 (Fig. 30 typically shows only one reflector 169. Fig. 30 also illustrates only an atom current which is incident upon and reflected by an upper half portion of the single reflector 169). The atom current component which is incident upon each reflector 169 is again reflected by its reflecting surface. The reflecting surface of each reflector 169 has a shape of a proper concave surface. Therefore, the divergent atom current components are reflected by the reflecting surfaces and properly focused as the result, to form parallel beams which are uniformly applied to the overall upper surface of the substrate 11. Further, the parallel beams are incident upon the upper surface of the substrate 11 from four directions at angles of incidence of  $55^\circ$ , for example.

## (A-10-3. Operation of Apparatus 124)

Referring to Fig. 28, the operation of the apparatus 124 is now described. It is assumed that the substrate 11 is prepared from an amorphous or polycrystalline SiO<sub>2</sub> (quartz) substrate, so that a single-crystalline Si thin film (which includes an axially oriented polycrystalline Si thin film) is formed on the quartz substrate 11. A polycrystalline Si thin film is previously formed on the quartz substrate 11 by CVD (chemical vapor deposition), for example.

First, the substrate 11 is mounted between the sample holder 10 and the reflecting unit 160. The heater provided in the sample holder 10 holds the sample, i.e., the substrate 11 and the polycrystalline Si thin film, at a temperature of 550 °C. Similarly to the apparatus 121, a gas which is introduced from an inert gas inlet pipe 7 is preferably prepared from inert Ne gas having smaller atomic weight than Si atoms.

Due to the action of an ECR ion source 2, an Ne atom current is supplied to the reflecting unit 160, to be incident upon the overall upper surface of the substrate 11 from four directions at angles of incidence of 55°, for example. In this case, the directions of incidence of the four Ne atom current components correspond to four directions which are perpendicular to four independent densest crystal planes of an Si single crystal to be formed, i.e., (111) planes. Similarly to the apparatus 121, energy of plasma which is formed by the ECR ion source 2 is so set that energy of the Ne atoms reaching the substrate 11 is lower than threshold energy in sputtering of Si by irradiation with the Ne atoms.

Thus, the law of Bravais acts on the polycrystalline Si thin film, whereby the Si atoms are rearranged in a portion close to the surface of the polycrystalline Si thin film so that surfaces perpendicular to the directions of incidence of the four components of the Ne atom current which is applied to the polycrystalline Si thin film define densest crystal planes. Namely, a layer in the vicinity of the polycrystalline Si thin film is converted to a single-crystalline Si layer having a regulated crystal orientation.

The temperature of the polycrystalline Si thin film is adjusted at 550°, i.e., within a range suitable for growing a seed crystal, as described above. Thus, the single-crystalline Si layer which is formed on the surface of the polycrystalline Si thin film serves as a seed crystal, to grow the single-crystalline Si layer toward a deep portion of the polycrystalline Si thin film. After a lapse of a constant time, the overall region of the polycrystalline Si thin film is converted to a single-crystalline Si layer. Thus, a single-crystalline Si layer having a regulated crystal orientation is formed on the quartz substrate 11. The single-crystalline Si thin film as formed is so oriented that the (100) plane is along its surface.

The angle of incidence of 55° shown in Fig. 29 is a mere example as a matter of course, and it is possible to introduce parallel beams into the substrate 11 at an arbitrary angle of incidence which is decided in response to the crystal structure of the desired single-crystalline thin film by properly changing the shapes and directions of the reflectors 169. Since the divergent beams are generated by the reflecting block 166, it is possible to uniformly irradiate a wide substrate 11 with parallel beams by properly adjusting the distances between the reflectors 169 and the symmetry axis of the reflecting block 166 in response to the width of the substrate 11.

Thus, according to this apparatus 124, it is possible to uniformly irradiate the overall surface of the substrate 11 having an area which is extremely larger than the section of each beam supplied from the ECR ion source 2 with atom current components at desired angles of incidence. Namely, it is possible to uniformly and efficiently form a desired single-crystalline thin film on the substrate 11 having a large area.

Further, it is possible to independently adjust the amounts of the four component beams passing through the openings 162 by independently adjusting the areas of the four openings 162 provided in the screen plate 164. Thus, it is possible to optimally set the respective amounts of the four component beams which are applied to the upper surface of the substrate 11 from a plurality of directions. For example, it is possible to uniformly regulate the amounts of the four component beams. Thus, a high-quality single-crystalline thin film can be efficiently formed.

Similarly to the apparatus 121, at least surfaces of respective members of the reflecting unit 160 such as the reflecting block 168, the rectifying member 168 and the reflectors 169 which are irradiated with the atom current components may be made of materials such as Ta, W, Pt or the like having higher threshold energy in sputtering than the thin film to be formed. Alternatively, the surfaces of the respective members of the reflecting unit 160 may be made of the same material as that for the thin film, similarly to the apparatus 121. Further, the surfaces of the respective members of the reflecting unit 160 may be made of a material containing an element which is heavier than that forming the ion current or the atom current as applied.

## (A-11. Tenth Preferred Embodiment)

An apparatus according to a tenth preferred embodiment of the present invention is now described. Fig. 31 is a front sectional view showing the overall structure of a beam irradiator according to this preferred embodiment. This apparatus 125 is adapted to form a polycrystalline thin film on a substrate 11 and to irradiate the same with an atom current at the same time, thereby sequentially converting the polycrystalline thin film as being grown to a single-crystalline thin film, similarly to the apparatus 120.

To this end, a reaction chamber 8 communicates with reaction gas supply pipes 13 in the apparatus 125, similarly to the apparatus 120. Reaction gases are supplied through the reaction gas supply pipes 13, for forming a film of a prescribed material on the substrate 11 by plasma CVD. The preferred embodiment shown in Fig. 31 is provided with three reaction gas supply pipes 13a, 13b and 13c. Other structural characteristics of this apparatus 125 are similar to those of the apparatus 124.

The apparatus 125 operates as follows: Similarly to the sixth preferred embodiment, it is assumed that the substrate 11 is prepared from polycrystalline  $\text{SiO}_2$  (quartz), so that a thin film of single-crystalline Si is formed on the quartz substrate 11. The reaction gas supply pipes 13a, 13b and 13c supply  $\text{SiH}_4$  (silane) gas for supplying Si, which is a main material for the single-crystalline Si, and  $\text{B}_2\text{H}_3$  (diborane) gas and  $\text{PH}_3$  (phosphine) gas for doping the substrate 11 with p-type and n-type impurities respectively. Ne gas is introduced from an inert gas inlet pipe 7 into a plasma chamber 4.

Due to the reaction gases supplied from the reaction gas supply pipes 13a, 13b and 13c and an  $\text{Ne}^+$  ion current or an Ne atom current generated by an ECR ion source 2, plasma CVD reaction progresses on the upper surface of the substrate 11, thereby growing an Si thin film of an amorphous structure.

The Ne atom current downwardly flowing from the ECR ion source 2 is incident upon the overall surface of the Si thin film being formed on the upper surface of the substrate 11 from four directions having angles of incidence of  $55^\circ$ , for example, due to action of a reflecting unit 160. Similarly to the apparatus 120, energy of plasma which is formed by the ECR ion source 2 is so set that incident energy of the four components is lower than threshold energy with respect to Si. Thus, the law of Bravais acts on the amorphous Si thin film as being grown, whereby the amorphous Si thin film being grown by plasma CVD is sequentially converted to a single-crystalline Si thin film having a regulated crystal orientation. As the result, single-crystalline Si having a single crystal orientation is formed on the substrate 11.

Also in this apparatus 125, the reflecting unit 160 is so employed that it is possible to uniformly irradiate the overall surface of the substrate 11 having an area which is extremely larger than the section of each beam supplied from the ECR ion source 2 with atom current components at desired angles of incidence without scanning the substrate 11, due to employment of the reflecting unit 160. Namely, it is possible to uniformly and efficiently form a desired single-crystalline thin film on the substrate 11 having a large area.

## (A-12. Eleventh Preferred Embodiment)

An apparatus 126 according to an eleventh preferred embodiment of the present invention is now described. Figs. 32 to 34 are a perspective view, a plan view and a front elevational view showing the apparatus 126 according to this preferred embodiment respectively. With reference to Figs. 32 to 34, the structure and the operation of the apparatus 126 according to this preferred embodiment are now described.

In this apparatus 126, an ECR ion source 2 is set in a horizontal state, to supply a gas beam in a horizontal direction which is parallel to the surface of a horizontally set substrate 11. A reflecting unit 180 is interposed in a path of the gas beam which is supplied from the ECR ion source 2 to reach the upper surface of the substrate 11.

In the reflecting unit 180, a reflecting block 186, a screen plate 184, a rectifying member 188 and a reflector 190 are successively arranged along the path of the gas beam. The reflecting block 186 is rotated/driven about its central axis which is in the form of a perpendicular prism. A distance between an outlet 9 and the reflecting block 186 is set at a sufficient length of at least 14 cm, for example, for converting an ion current which is outputted from the ECR ion source 2 to a neutral atom current. Thus, a substantially neutral atom current reaches the reflecting block 186.

Fig. 35 is a plan view for illustrating the operation of the reflecting block 186. As shown in Fig. 35, an atom current which is incident upon the reflecting block 186 is scattered to a number of directions in a horizontal plane by rotation of the reflecting block 186. Namely, the reflecting block 186 substantially generates divergent beams whose beam sections are enlarged linearly or in the form of strips, i.e., substantially one-dimensionally, with progress of the beams.

The screen plate 184 selectively passes only components of the divergent atom current having scattering angles in a specific range. The atom current components passed through the screen plate 184 are passed through the rectifying member 188, to be precisely regulated in directions of progress. The rectifying member 188 is structured similarly to the rectifying member 168. In place of the shape of a prism shown in Fig. 35, the reflecting block 186 may be in the form of a triangle pole, a hexagonal pole or the like, for example.

Referring again to Figs. 32 to 34, the atom current components passed through the rectifying member 188 are incident upon the reflector 190 which is in the form of a strip along the horizontal direction. A reflecting surface of the reflector 190 has a proper concave shape. Thus, the divergent atom current components are reflected by this reflecting surface and properly focused to form parallel beams, which are applied to the upper surface of the substrate 11 linearly or in the form of strips. Further, the parallel beams are incident upon the upper surface of the substrate 11 at angles of incidence of  $35^\circ$ , for example. As shown in Fig. 33, two sets of the members from the reflecting block 186 to the reflector 190 arranged along the path of the atom current are set. Thus, atom currents are incident upon the substrate 11 from opposite two directions at angles of incidence of  $35^\circ$  respectively.

Each atom current is scattered by each reflecting block 186 to be substantially one-dimensionally diverged, whereby it is possible to apply parallel beams to a linear or strip-shaped region having a width which is extremely larger than the diameter of the beam supplied from the ECR ion source 2 by sufficiently setting the distance between the reflecting block 186 and the reflector 190.

The apparatus 126 has a sample holder (not shown) for receiving the substrate 11, and this sample holder is horizontally movable by a horizontal moving mechanism (not shown). Following such horizontal movement of the sample holder, the substrate 11 is moved in parallel along a direction perpendicular to (intersecting with) the linear or strip-shaped region receiving the atom currents. Thus, it is possible to implement irradiation of the overall region of the substrate 11 by scanning the substrate 11. Due to such scanning of the substrate 11, it is possible to uniformly irradiate the wide substrate 11 with atom current components.

This apparatus 126 may comprise reaction gas supply pipes 13a, 13b and 13c similarly to the apparatus 120, to form a thin film of a prescribed material on the substrate 11 and to sequentially convert the thin film to a single crystal. Alternatively, the sample holder may be provided with a heater similarly to the apparatus 121, to convert a thin film of a prescribed material which is previously deposited on the substrate 11 to a single-crystalline thin film. Since the two atom currents are incident from opposite directions at the same angles of incidence of  $35^\circ$ , the single-crystalline thin film formed on the substrate 11 is so oriented that its (110) plane is along its surface.

It is possible to form a single-crystalline thin film which is so oriented that a crystal plane other than the (110) plane is along its surface, by changing the positional relation between the reflecting units 180, the angles of the reflectors 190 and the like. For example, it is possible to form a single-crystalline thin film which is so oriented that its (100) plane is along its surface by arranging at least two sets of reflecting units 180 so that central axes of atom currents from the reflecting blocks 186 toward the reflectors 190 are at angles of  $90^\circ$  or  $180^\circ$  and setting shapes and directions of the reflectors 190 so that angles of incidence of the atom currents incident upon the substrate 11 from the reflecting units 180 are  $55^\circ$ .

Further, it is possible to form a single-crystalline thin film which is so oriented that its (111) plane is along its surface by arranging at least two sets of three sets of reflecting units 180 so that central axes of atom currents from the reflecting blocks 186 toward the reflectors 190 are each shifted by  $120^\circ$  and setting shapes and directions of the reflectors 190 so that angles of incidence of the atom currents incident upon the substrate 11 from the reflecting units 180 are at  $70^\circ$ .

Similarly to the apparatus 124, at least surfaces of respective members of the reflecting units 160 such as the reflecting blocks 168, the rectifying members 168 and the reflectors 169 which are irradiated with the atom current components may be made of materials such as Ta, W, Pt or the like having higher threshold energy in sputtering than the thin film to be formed. Alternatively, the surfaces of the respective members of the reflecting units 160 may be made of the same material as that for the thin film. Further, the surface of the respective members of the reflecting units 160 may be made of a material containing an element which is heavier than that forming the ion current or the atom current as applied.

#### (A-13. Twelfth Preferred Embodiment)

An apparatus 127 according to a twelfth preferred embodiment of the present invention is now described. Fig. 36 is a perspective view showing the structure of the apparatus 127 according to this preferred embodiment. As shown in Fig. 36, this apparatus 127 comprises a reflecting unit 191. This

reflecting unit 191 is characteristically different from the reflecting unit 180 in a point that the same has an electrostatic electrode 306 in place of the reflecting blocks 186. An ion current is incident upon the electrostatic electrode 196, in place of a neutral atom current. Namely, a distance between an outlet 9 and this electrostatic electrode 196 is set to be sufficiently short so that the ion current outputted from an ECR ion source 2 is hardly converted to a neutral atom current but incident upon the electrostatic electrode 196 as such.

The electrostatic electrode 196 is provided with an ac power source 197. This ac power source 197 supplies a fluctuation voltage which is formed by an alternating voltage superposed on a constant bias voltage to the electrostatic electrode 196. Consequently, the ion current which is incident upon the electrostatic electrode 196 is scattered into a number of directions within a horizontal plane by action of a fluctuating electrostatic field.

Thus, scattering of the ion current is implemented by the fluctuation voltage which is supplied by the ac power source 197 in this apparatus 127, whereby it is possible to easily suppress scattering of the ion current in unnecessary directions cut by screen plates 184. Namely, it is possible to efficiently apply the ion current which is supplied by the ECR ion source 2 to a substrate 11. Further, it is also possible to scatter the ion current to respective scattering directions with higher uniformity by setting the waveform of the fluctuation voltage supplied by the ac power source 197 in the form of a chopping wave, for example.

#### (A-14. Modifications of Fifth to Twelfth Preferred Embodiments)

(1) While the shapes of the reflecting blocks 166 and the arrangement of the reflectors 169 are selected to four-fold rotation symmetry in the sixth and tenth preferred embodiments, the same can alternatively be selected in two-fold or three-fold rotation symmetry, for example. Namely, it is possible to arbitrarily select the number of components of the atom current which are incident at different angles of incidence in response to the crystal structure of the desired single-crystalline thin film. The shape of the reflecting block 166 may be selected in a rotation symmetrical manner such as in the form of a cone. At this time, only a single reflecting block 166 is available regardless of the number of the directions of incidence upon the substrate 11. Thus, it is also possible to form a single-crystalline thin film having a crystal structure other than a diamond structure according to the inventive apparatus, while it is also possible to form a single-crystalline thin film having various crystal orientations in a single crystal structure. Further, the material for forming the single-crystalline thin film is not restricted to Si since it is possible to cope with an arbitrary crystal structure, whereby it is possible to form a semiconductor single-crystalline thin film of GaAs or GaN, for example.

(2) In each of the ninth and tenth preferred embodiments, each rectifying member 168 for rectifying the directions of the atom current components may be interposed in a path of the atom current which is reflected by the reflector 169 and directed toward the substrate 11, in place of the path of the atom current directed from the reflecting block 166 toward the reflector 169. Further, the rectifying members 168 may be interposed in both of these paths.

On the other hand, the apparatus may not be provided with the rectifying members 168. When the apparatus is provided with the rectifying members 168, however, it is possible to precisely set the directions of incidence of the atom current components upon the substrate 11 without strictly setting the shapes, arrangement etc. of the reflecting blocks 166 and the reflectors 169.

The above also applies to the rectifying members 188 in the eleventh and twelfth preferred embodiments.

(3) In each of the fourth to eleventh preferred embodiments, the ECR ion source 2 may be replaced by another beam source for generating a neutral atom current or a neutral molecular flow, or a neutral radical flow. A beam source for generating such a neutral atom or radical current has already been commercially available. Since a neutral atom or radical beam can be obtained by such a beam source, it is possible to form a single-crystalline thin film on an insulating substrate 11 with no requirement for means for neutralizing an ion current, similarly to the case of employing the ECR ion source 2.

(4) In each of the fourth to twelfth preferred embodiments, the ECR ion source 2 may be replaced by another ion source such as a Cage type or Kaufmann type source. In this case, however, the flow of the as-generated ion current may be diffused by repulsive force by static electricity between ions to be weakened in directivity, and hence means for neutralizing the ions or means such as a collimator for improving directivity of the ion current is preferably interposed in the path of the ion current.

Particularly when the substrate 11 is made of an electrically insulating material, means for neutralizing ions is preferably interposed in the path of the ion current, in order to prevent the substrate 11 from accumulation of electric charges inhibiting progress of irradiation. In the apparatus according to each

preferred embodiment comprising the ECR ion source 2, on the other hand, a neutral atom current can be easily obtained in a shape close to a parallel current with no means for neutralizing the ion current.

When means for neutralizing ions is set in the apparatus according to the twelfth preferred embodiment, the same is set downstream the electrostatic electrode 196.

5 (5) The beam irradiator described in each of the aforementioned preferred embodiments is not restricted to an apparatus for forming a single-crystalline thin film, but is also applicable to an apparatus for applying gas beams from a plurality of directions for another purpose. Particularly the apparatus shown in each of the ninth to twelfth preferred embodiments is suitable for a purpose of uniformly irradiating a wide substrate with gas beams from a plurality of directions.

10 (6) When the thin film to be formed contains N (nitrogen element) which is a gas under a normal temperature such as GaN in each of the fourth to twelfth preferred embodiments, the gas may be prepared from gaseous nitrogen. In this case, the characteristics of the thin film will not be deteriorated even if the gas remains in the thin film.

15 (B. Preferred embodiments in Relation to Selective Formation and Further Efficient Formation of Single-Crystalline Thin Film)

On the basis of the aforementioned method, description is now made on preferred embodiments in relation to methods enabling selective formation of single-crystalline thin films on specific regions of  
20 substrates and further efficient formation of single-crystalline thin films on substrates.

(B-1. Thirteenth Preferred embodiment)

Figs. 37 to 42 are process diagrams in relation to a method according to a thirteenth preferred  
25 embodiment. First, an upper surface of an Si single-crystalline substrate 102 is oxidized to form an SiO<sub>2</sub> film 104 which is an insulator, as shown in Fig. 37. Further, an amorphous or polycrystalline Si thin film 106 is formed on the SiO<sub>2</sub> film 104 by CVD, for example.

Then, a thin film 108 of SiO<sub>2</sub> or Si<sub>3</sub>N<sub>4</sub> is formed on the Si thin film 106 and thereafter this thin film 108 is selectively etched to form an opening in a desired specific region, as shown in Fig. 38. This thin film 108  
30 having an opening serves as a masking material in a subsequent step. The selective etching is carried out by well-known photolithography sequentially through processes of resist application, pre-baking, exposure, development and post-baking. At this time, the exposure is carried out through a masking material having a prescribed pattern enabling selective etching, and separation of a resist material is carried out after the exposure. A portion of the Si thin film 106 which is exposed in the opening is subjected to washing by a  
35 method such as the so-called reverse sputtering or the like.

Thereafter the apparatus 101 is employed to irradiate the overall upper surface of the Si single-crystalline substrate 102 with an Ne atom current 110 from directions which are perpendicular to a plurality of densest planes of a single-crystalline thin film to be formed with proper irradiation energy, as shown in Fig. 39. Ne atoms are lighter than Si which is an element forming the Si thin film 106 as irradiated and Si  
40 which has the maximum atomic weight among elements forming the masking material 108 as irradiated, whereby the same hardly remain in the masking material 108 and the Si thin film 106 following the irradiation.

The Si thin film 106 is selectively irradiated with the Ne atom current only in the opening of the masking material 108. Therefore, the Si thin film 106 is selectively converted to a single-crystalline layer 112 having a regulated crystal orientation in a region corresponding to the opening of the masking material 108, i.e., the  
45 aforementioned specific region, as shown in Fig. 40.

Then, the masking material 108 is removed and the upper surface is thermally oxidized to form an oxide film 114, as shown in Fig. 41. In general, a reaction rate of thermal oxidation in an amorphous or polycrystalline layer is larger by 2 to 5 times than that in a single-crystalline layer. Therefore, a portion of the oxide film 114 located on the Si thin film 106 is larger in thickness by about 2 to 5 times than that  
50 located on the single-crystalline layer 112.

Thereafter the overall upper surface of the oxide film 114 is properly etched to expose the upper surface of the single-crystalline layer 112, as shown in Fig. 42. At this time, the oxide film 116 remains on the Si thin film 106. The single-crystalline layer 112 can be provided with a desired element such as a transistor element, for example. At this time, the oxide film 116 serves as the so-called LOCOS (local oxidation of silicon) layer which isolates the element formed on the single-crystalline layer 112 from other elements. The Si single-crystalline substrate 102 itself is already provided therein with desired elements. Therefore, it is possible to implement a device having a three-dimensional structure by integrating a new



element into the single-crystalline layer 112. In the method according to this preferred embodiment, the LOCOS layer is formed on an amorphous or polycrystalline layer, whereby the same can be efficiently formed in a short time, to improve the throughput in an thermal oxidation device.

In the method according to this preferred embodiment, further, a single-crystalline thin film can be  
 5 formed on the SiO<sub>2</sub> film 104 which is an insulator, whereby the element provided in the Si single-crystalline substrate 102 can be easily isolated from a new element provided thereon.

(B-2. Fourteenth Preferred embodiment)

10 Figs. 43 to 51 are process diagrams in relation to a fourteenth preferred embodiment. As shown in Fig. 43, a transistor is previously formed on a single-crystalline Si substrate. Namely, n-type source and drain layers 204 and 206 which are isolated from each other are selectively formed on an upper surface of a p-type single-crystalline Si substrate 202. Further, a gate electrode 210 is formed on the upper surface of the substrate 202 in a region corresponding to that between these layers 204 and 206, through a gate oxide  
 15 film 208. Namely, this transistor is an n-channel MOS transistor. The gate oxide film 208 is made of SiO<sub>2</sub>, and the gate electrode 210 is made of polycrystalline Si.

Then, an insulating film 212 of SiO<sub>2</sub> is formed entirely over the upper surfaces of the substrate 202 and the gate electrode 210, as shown in Fig. 44. Thereafter an amorphous or polycrystalline Si film 214 is formed on the overall surface of the insulating film 212, as shown in Fig. 45.

20 Then, the Si film 214 is selectively etched to be left only in a desired specific region. Fig. 46 shows an Si film 216 which is defined in the specific region by the selective etching.

Then, the apparatus 101 is employed to irradiate overall upper surfaces of the insulating film 212 and the Si film 216 with an Ne atom current 218 from directions which are perpendicular to a plurality of densest planes of a single-crystalline thin film to be formed with proper irradiation energy, as shown in Fig.  
 25 47. Ne atoms are lighter than Si forming the Si film 216 and the insulating film 212, whereby the same hardly remain in these layers following the irradiation. Due to this irradiation, the Si film 216 is converted to a single-crystalline Si thin film 220 having a regulated crystal orientation, as shown in Fig. 48. At this time, a region of the insulating film 212 which is exposed on the upper surface is also converted to a single-crystalline thin film.

30 Then, the single-crystalline Si thin film 220 is doped with an n-type impurity, to be converted to an n-type Si thin film, as shown in Fig. 48. Thereafter a gate oxide film 228 and a gate electrode 230 are selectively formed on the upper surface of the n-type single-crystalline thin film 220. Further, these are employed as masks to selectively dope the upper surface of the single-crystalline Si thin film 220 with a p-type impurity, thereby forming a drain layer 224 and a source layer 226. Namely, these layers are formed  
 35 by self alignment. Due to this step, the single-crystalline Si thin film 220 forms a p-channel MOS transistor.

Then, an insulating film 232 of SiO<sub>2</sub> or the like is formed over the entire upper surface. Then, desired portions of the insulating films 232 and 212 are selectively etched to form an opening serving as a contact hole. Further, a conductive wiring layer 234 of aluminum, for example, is applied onto the overall upper surface of the insulating film 232 including the contact hole, and thereafter the wiring layer 234 is selectively  
 40 removed to couple the elements in a desired manner (Fig. 50).

As hereinabove described, it is possible to selectively form a single-crystalline layer on a desired specific region of the substrate 202 in the method according to this preferred embodiment. Further, it is possible to implement a device having a three-dimensional structure by forming a new element on the single-crystalline layer, since the substrate 202 itself is already provided with an element. In the method  
 45 according to this preferred embodiment, a single-crystalline thin film can be formed on the insulating film 212 of SiO<sub>2</sub>, whereby the element provided in the substrate 202 can be easily isolated from a new element provided thereon in the three-dimensional device.

Further, it is also possible to form a plurality of new elements on the substrate 202, as shown in Fig. 51. At this time, two new elements (two p-channel MOS transistors in Fig. 51) are provided in single-crystalline  
 50 Si thin films 220 which are formed independently of each other. Thus, these elements can be easily isolated with no provision of a LOCOS layer or an isolation layer. Consequently, steps of manufacturing the device are simplified and the degree of integration of the elements is improved.

Although an n-type impurity is introduced into the selectively formed single-crystalline Si thin films 220 in the aforementioned preferred embodiment, the same may alternatively be introduced in the stage of the  
 55 Si film 216, or into the overall surface of the Si film 214. In any method, it is possible to finally form the device of the three-dimensional structure shown in Fig. 50 or 51.

## (B-3. Fifteenth Preferred embodiment)

As hereinabove described, the Si film 214 (Fig. 45) is selectively removed to form the Si film 216 (Fig. 46) and thereafter an Ne atom current is applied (Fig. 47) to convert the same to the single-crystalline Si thin film 220 (Fig. 48). Alternatively, the overall upper surface of the Si film 214 shown in Fig. 45 may be irradiated with the Ne atom current to be converted to a single-crystalline thin film, so that the Si film 214 is thereafter selectively removed to form the single-crystalline Si thin film 220 shown in Fig. 48. Subsequent steps are similar to those of the fourteenth preferred embodiment.

## 10 (B-4. Sixteenth Preferred embodiment)

As hereinabove described, the amorphous or polycrystalline Si film 214 is previously formed (Fig. 45) and thereafter irradiated with the Ne atom current, to be converted to a single-crystalline thin film in the fifteenth preferred embodiment. Alternatively, the apparatus 100 may be employed after the step shown in Fig. 43 is completed to grow an amorphous Si thin film on the insulating film 212 while simultaneously carrying out application of an Ne atom current, thereby forming a single-crystalline Si thin film on the insulating film 212. Thereafter the single-crystalline Si thin film is selectively removed, to form the single-crystalline Si thin film 220 shown in Fig. 48. Subsequent steps are similar to those of the fourteenth and fifteenth preferred embodiments.

20

## (B-5. Seventeenth Preferred embodiment)

Figs. 52 to 60 are process diagrams in relation to a method according to a seventeenth preferred embodiment. As shown in Fig. 52, an amorphous or polycrystalline Si thin film is first formed on a substrate 502 which is made of SiO<sub>2</sub>, by CVD or the like. Thereafter the apparatus 100 is employed to irradiate the Si thin film with an Ne atom current, thereby converting the Si thin film to a single-crystalline Si thin film 504 which is regulated in crystal orientation so that a (100) plane is exposed on the upper surface. Alternatively, the apparatus 101 may be employed in place of the apparatus 100, to grow an amorphous Si thin film on the substrate 502 while irradiating the same with an Ne atom current for forming the single-crystalline Si thin film 504.

30

Then, the upper surface of the single-crystalline Si thin film 504 is selectively thermally oxidized, to form LOCOS layers 506, as shown in Fig. 53. Thereafter p-type or n-type impurities are introduced into the respective ones of single-crystalline Si thin film regions 508, 510 and 512 which are isolated from each other by the LOCOS layers 506, thereby converting these single-crystalline Si thin film regions 508, 510 and 512 to p-type or n-type semiconductor regions, as shown in Fig. 54.

35

Then, gate oxide films 514 and 515 of SiO<sub>2</sub> and gate electrodes 516 and 517 of polycrystalline Si are formed on the upper surfaces of the single-crystalline Si thin film regions 512 and 510 respectively, as shown in Fig. 55. Thereafter these gate oxide films 514 and 515 and gate electrodes 516 and 517 are used as masks to selectively introduce n-type and p-type impurities into the single-crystalline Si thin film regions 512 and 510 from the upper surfaces, as shown in Fig. 56. Consequently, source and drain layers are formed in the single-crystalline Si thin film regions 512 and 510 respectively.

40

Then, an insulating film 526 of SiO<sub>2</sub> is formed on an upper surface portion excluding the upper surface of the

single-crystalline Si thin film region 508, as shown in Fig. 57. Thereafter the apparatus 101 is employed to apply an Ne atom current from the upper surface, as shown in Fig. 58. At this time, only the single-crystalline Si thin film region 508 which is not covered with the insulating film 526 of SiO<sub>2</sub> is selectively irradiated. Directions of irradiation are set in a plurality of directions which are perpendicular to a plurality of densest planes (111) of single-crystalline Si which is so oriented that one (111) plane is exposed on the upper surface. Thus, the single-crystalline Si thin film region 508 is converted to a single-crystalline Si layer 530 which is so regulated in crystal orientation that the (111) plane is exposed on the upper surface. Namely, the crystal orientation of the single-crystalline Si thin film region 508 is converted. The region 528 which is masked with the insulating film 526 of SiO<sub>2</sub> and not subjected to irradiation is a region to be provided with a CMOS element. On the other hand, the single-crystalline Si layer 530 which is converted in crystal orientation is provided with a pressure sensor, for example. Then, an insulating film 532 of SiO<sub>2</sub> is formed on the overall upper surface, as shown in Fig. 59. This insulating film 532 includes the insulating film 526. Thereafter a desired portion of the insulating film 532 is selectively etched to form an opening for serving as a contact hole. Further, a conductive wiring layer 534 of aluminum, for example, is applied to the overall upper surface of the insulating film 532 including the contact hole, and this wiring layer 534 is

55

thereafter selectively removed to couple the elements in a desired manner (Fig. 60).

Due to the aforementioned steps, a CMOS 528 and a pressure sensor 536 are formed in the single-crystalline Si thin film 504 by single-crystalline Si materials having different crystal orientations in a parallel manner. The single-crystalline Si forming the CMOS 528 is preferably oriented so that a (100) plane is  
 5 along the major surface of the substrate, while the single-crystalline Si forming the pressure sensor is preferably oriented so that the (111) plane is along the major surface of the substrate. In the method according to this preferred embodiment, it is possible to form a composite device in which a plurality of elements having different preferable crystal orientations are provided in the same single-crystalline Si thin film. In the method according to this preferred embodiment, further, it is possible to form an element which  
 10 is made from single-crystalline Si on the substrate 502 of SiO<sub>2</sub>, which is not a single crystal. Namely, this method has such an advantage that the material for the substrate is not limited.

(B-6. Eighteenth Preferred embodiment)

As hereinabove described, an amorphous or polycrystalline Si thin film is formed on the substrate 502  
 15 by CVD or the like and thereafter the overall upper surface of this Si thin film is irradiated with an Ne atom current so that the overall region thereof is converted to the single-crystalline Si thin film 504 which is so oriented that the (100) plane is exposed on the upper surface (Fig. 52). Alternatively, a masking material 540 having a prescribed masking pattern may be formed on an upper surface to be thereafter irradiated  
 20 with an Ne atom current, so that only a region of an Si thin film to be provided with a CMOS is selectively irradiated with the Ne atom current, as shown in Fig. 61. Thus, only the region to be provided with a CMOS is converted to a single-crystalline Si thin film 542 having an upper surface of a (100) plane, while another region 544 remains in the original state of the amorphous or polycrystalline Si thin film. Subsequent steps are similar to those of the seventeenth preferred embodiment.

The method according to the eighteenth preferred embodiment has an effect similar to that of the  
 25 seventeenth preferred embodiment. Namely, it is possible to form a composite device in which a plurality of elements having different preferable crystal orientations are provided in the same single-crystalline Si thin film. Further, this preferred embodiment has such an advantage that the material for the substrate is not limited, similarly to the seventeenth preferred embodiment.

30

(B-7. Nineteenth Preferred embodiment)

Fig. 62 is a front elevational view showing the structure of a sample holder in an apparatus for forming a  
 single-crystalline thin film according to a nineteenth preferred embodiment of the present invention. This  
 35 sample holder is assembled into the apparatus 100 in place of the sample holder 10. In this sample holder, a reflector 12 is fixed to a fixed table 702 through supports 712. Further, a movable table 706 is horizontally slidably supported by the fixed table 702. A seating portion of this movable table 706 is fitted with a screw 708 which is rotated/driven by a motor 710, to be horizontally moved following rotation of the screw 708. This seating portion is provided with a horizontal driving mechanism (not shown) having a motor and a  
 40 screw similarly to the fixed table 702, to horizontally drive an upper member of the movable table 706. A direction for sliding the seating portion is perpendicular to that for sliding the upper member. A substrate 11 to be irradiated is placed on the upper member. This substrate 11 is located under the reflector 12.

Fig. 63 is a plan view typically showing an operation of this sample holder. The substrate 11 is relatively  
 45 scanned with respect to the reflector 12 along two orthogonal directions by action of the two horizontal driving mechanisms. Therefore, it is possible to homogeneously irradiate the overall surface of the substrate 11, which has a wider area as compared with an opening of the reflector 12 serving as an opening for passing beams, with the beams.

When this sample stand is employed, it is possible to efficiently apply the beams by employing an  
 apparatus 101a for forming a single-crystalline thin film which comprises a magnetic lens 720, as shown in  
 50 Fig. 64. The magnetic lens 720 is adapted to focus an ion current which is downwardly sprayed from an ion source 2 into the form of a strip. Fig. 65 is a model diagram showing such a state that an ion current is focused by the magnetic lens 720. Due to the action of the magnetic lens 720, the ion current has a strip-type sectional shape in the vicinity of the reflector 12f. Therefore, the reflector 12f also has a shape along this strip. Similarly to those in the apparatuses 100 and 101, the ion current is substantially converted to a  
 55 neutral atom current in the vicinity of the reflector 12f. The substrate 11 is irradiated with components 726 of the atom current reflected from the reflector 12f and directly incident components 724. The angle of inclination of the reflector 12f is so adjusted that directions of incidence of these two components are orthogonal to a plurality of densest planes of a single-crystalline thin film to be formed respectively.

It is possible to efficiently irradiate a wide region, on the substrate 11 in single scanning, by scanning the substrate 11 in a direction 728 which is perpendicular to the "strip of the atom current". Therefore, it is possible to attain irradiation of the substrate 11 having a wide area in a small number of scanning times. In other words, it is possible to form a single-crystalline thin film with higher efficiency by employing the apparatus 101a. This is particularly effective when the width of the substrate 11 is shorter than a major axis width of the "strip of the atom current". At this time, the substrate 11 may simply be scanned along one direction 728, whereby a single-crystalline thin film can be further efficiently formed. Further, the driving mechanism provided in the sample holder is sufficiently implemented only by a single driving mechanism which is integrated in the fixed table 702, whereby the sample holder is simplified in structure.

(B-8. Twentieth Preferred embodiment)

Fig. 66 is a front elevational view typically showing the structure of a reflector support which is provided in an apparatus for forming a single-crystalline thin film according to a twentieth preferred embodiment of the present invention. This reflector support rotatably supports an end of a reflector 802 by a hinge 804, while rotatably supporting another end by another hinge 806 which is provided on the forward end of a connecting bar 808. The connecting bar 808 is axially driven by a piston 810. Following the axial movement of the connecting bar 808, the reflector 802 is rotated about the hinge 804. Consequently, an angle  $\theta$  of inclination of a reflecting surface is changed in the reflector 802. Namely, the angle of inclination is variable in the reflecting surface of the reflector 802 provided in this apparatus. Thus, it is possible to form single-crystalline thin films having various crystal orientations and crystal structures by employing a single apparatus. Namely, formation of various types of single-crystalline thin films can be economically attained.

Further, it is possible to efficiently form various types of single-crystalline thin films on a single substrate 11. This is because various types of single-crystalline thin films can be formed while inserting the substrate 11 in the apparatus. It is possible to instantaneously set a prescribed angle of inclination by controlling the operation of the piston 810 by a computer.

(B-9. Twenty-first Preferred embodiment)

Fig. 67 is a plan view typically showing the structure of a reflector support 902 which is provided in an apparatus for forming a single-crystalline thin film according to a twenty-first preferred embodiment of the present invention. This reflector support 902 comprises a plurality of arms 904 which are rotated/driven about vertical axes. Each one of a plurality of reflectors 906a to 906f, which are different from each other, is mounted on a forward end portion of each arm 904. The plurality of reflectors 906a to 906f are so formed that numbers or angles of incidence of atom current components which are incident upon a substrate 11 are different from each other. Namely, the reflectors 906a to 906f are different from each other in numbers of reflecting surfaces and angles of inclination. Since the arms 904 are rotated/driven, it is possible to arbitrarily select a desired reflector to be set in an irradiated region 908 which is irradiated with the atom current from the plurality of types of reflectors 906a to 906f.

Therefore, it is possible to form single-crystalline thin films having various crystal orientations and crystal structures only by a single apparatus, similarly to the apparatus according to the twentieth preferred embodiment. Namely, it is possible to economically form various types of single-crystalline thin films. Further, it is possible to efficiently form various types of single-crystalline thin films on a single substrate 11.

(B-10. Twenty-second Preferred embodiment)

The reflector(s) and the reflector support provided in each of the nineteenth to twenty-first preferred embodiments can also be employed in the apparatus 101, in place of the apparatus 100. Namely, the reflector(s) and the reflector support can be applied to both of an apparatus for forming an amorphous or polycrystalline thin film and thereafter converting the same to a single-crystalline film and an apparatus for simultaneously carrying out these operations.

(B-11. Twenty-third Preferred embodiment)

Fig. 68 is a plan view typically showing the structure of an apparatus for forming a single-crystalline thin film according to a twenty-third preferred embodiment of the present invention. In this apparatus, an etching unit portion 1104 for etching a substrate 11, a film forming unit portion 1106 for forming an amorphous or

polycrystalline thin film on the substrate 11, and an irradiation unit portion 1108 for irradiating the substrate 11 with an atom current are arranged around a carrier chamber 1102. Further, treatment chambers for storing the substrate 11 in the respective unit portions 1104, 1106 and 1108 communicate with each other through the carrier chamber 1102. The carrier chamber 1102 is provided with an inlet 1110 and an outlet 1112 for receiving and discharging the substrate 11 respectively. Both of the inlet 1110 and the outlet 1112 are provided with airtight switchable doors (not shown). The carrier chamber 1112 is provided with a carrier robot 1114, which receives and discharges the substrate 11 while automatically inserting and extracting the same into and from the respective treatment chambers.

In the apparatus according to this preferred embodiment, the respective treatment chambers communicate with each other, whereby it is possible to immediately start formation of a thin film after carrying out etching for removing an oxide film before forming a thin film on the substrate 11 while preventing new progress of oxidation. Thus, it is possible to reliably form a thin film having excellent and homogeneous characteristics while efficiently carrying out respective treatments. Further, it is possible to efficiently carry the substrate 11 into the respective treatment chambers due to provision of the carrier robot 1114.

(B-12. Twenty-fourth Preferred embodiment)

Fig. 69 is a front sectional view typically showing the structure of an apparatus for forming a single-crystalline thin film according to a twenty-fourth preferred embodiment of the present invention. This apparatus comprises two ECR ion sources 1204a and 1204b, in place of the reflector 12. Namely, atom currents which are supplied from the ECR ion sources 1204a and 1204b are directly incident upon the upper surface of a substrate 11. These ECR ion sources 1204a and 1204b are set to have prescribed angles with respect to the major surface of the substrate 11. Consequently, the atom currents are incident upon the upper surface of the substrate 11 in directions of incidence which are perpendicular to a plurality of densest planes of a single-crystalline thin film to be formed. It is possible to form a single-crystalline thin film on the substrate 11 also by employing such an apparatus having a plurality of beam sources, in place of the apparatus 100 comprising the reflector 12.

In this apparatus, a mechanism for adjusting the attitude of the substrate 11 is further added to a sample holder 1208 which is set in a treatment chamber 1202. Namely, the sample holder 1208 is rotatable in a horizontal plane, whereby it is possible to rotate the substrate 11 for directing an orientation flat 11a, which may be provided in the substrate 11, to a prescribed direction. When the substrate 11 which is placed on a carrier unit 1206 is carried through an inlet 1204 provided on a side surface of the treatment chamber 1202 of this apparatus and placed on the sample holder 1208, optical means detects the direction of the orientation flat 11a and the sample holder 1208 is rotated by a prescribed amount in order to correct the direction to a prescribed one. The amount of rotation is calculated by a control unit part (not shown) storing a computer therein.

The direction of the orientation flat 11a generally has a constant relation to the crystal orientation of a single-crystalline layer forming the substrate 11. Therefore, it is possible to set the crystal orientation of the single-crystalline layer forming the substrate 11 and that of a single-crystalline thin film to be newly formed thereon regularly in a desired relation by setting the orientation flat 11a in a prescribed direction. Thus, it is also possible to epitaxially form a new single-crystalline thin film on the single-crystalline layer forming the substrate 11, for example, by employing this apparatus.

Fig. 70 is a front sectional view typically showing the structure of another apparatus for forming a single-crystalline thin film according to the twenty-fourth preferred embodiment of the present invention. Also in this apparatus, it is possible to horizontally rotate a substrate 11 to adjust its attitude. Namely, a sample holder 1208 can be horizontally rotated by a rotation driving part 1214. This apparatus further comprises a crystal orientation detecting unit portion 1210 for detecting the crystal orientation of the substrate 11 having a single-crystalline structure. The crystal orientation detecting unit portion 1210 has a function of irradiating the surface of the substrate 11 with X-rays, for example, and catching a diffraction image thereof. An electric signal expressing the diffraction image obtained by the crystal orientation detecting unit portion 1210 is transmitted to a control part 1212 storing a computer therein. The control part 1212 decodes the diffraction image from this signal to calculate the crystal orientation in the substrate 11 while calculating difference between the same and a desired crystal orientation, and instructs an angle of rotation for correcting the orientation to the rotation driving part 1214. The rotation driving part 1214 rotates the sample holder 1208 along the instruction. The aforementioned operation eliminates the difference, to regularly set the crystal orientation of the single-crystalline layer forming the substrate 11 and that of the single-crystalline thin film to be newly formed thereon in a desired relation.

The apparatus shown in Fig. 70 has such an advantage that the crystal orientation can be adjusted with respect to an arbitrary single-crystalline substrate having no orientation flat 11a, dissimilarly to the apparatus shown in Fig. 69. Considering that the relation between the crystal orientation of the substrate 11 and the direction of the orientation flat 11a is not accurate in general, it can be said that the apparatus shown in Fig. 70 can adjust the crystal orientation in higher accuracy as compared with the apparatus shown in Fig. 69.

(B-13. Twenty-fifth Preferred embodiment)

Fig. 71 is a partially fragmented front elevational view typically showing a sample holder which is provided in an apparatus for forming a single-crystalline thin film according to a twenty-fifth preferred embodiment of the present invention. This sample holder is employed along with the apparatus 101. Namely, this sample holder is employed in an apparatus for growing an amorphous or polycrystalline thin film by supplying a reaction gas onto a substrate 11 while irradiating the same with an atom current. In this sample holder, a reflector 12 is fixedly supported on a fixed table 1302 through a support 1304. A rotatable table 1306 for receiving the substrate 11 is connected with a rotary shaft 1308, which is rotated/driven by an rotation/driving unit portion (not shown) thereby rotating the rotatable table 1306. Upon such rotation of the rotatable table 1306, the substrate 11 which is placed thereon is rotated. It is possible to eliminate inhomogeneity appearing in the thickness of the as-grown thin film due to inhomogeneity in a reaction system, i.e., inhomogeneity in distribution of a reaction gas onto the substrate 11 or that in temperature distribution on the substrate 11 by rotating the substrate 11 and properly changing its direction. On the other hand, relative positions of the reflector 12 and the substrate 11 are changed upon rotation of the substrate 11. When this sample holder is employed, therefore, application of the atom current is intermittently carried out so that the direction of the substrate 11 is changed to carry out only growth of a thin film, i.e., only film formation, with limitation to irradiation pauses. Further, the direction of the substrate 11 is returned to the original one before next irradiation is started. These operations are repeated to carry out film formation and conversion to a single crystal.

Fig. 72 is a plan view typically showing another example of the sample holder. This sample holder is adapted to implement treatment of the substrate 11 in a batch processing system, and employed in combination with the apparatus 100. In this sample holder, substrates 11 to be treated are placed on peripheral portions of a rotary shaft of a rotatable table 1310. Fig. 72 illustrates such an example that four substrates 11 are placed. Among these substrates 11, only that provided in a position of "A" in Fig. 72, for example, is irradiated with an atom current. A reaction gas is supplied in all positions "A" to "D".

When the rotatable table 1310 is intermittently rotated, the substrate 11 occupying the position "A" is subjected to both of irradiation and supply of the reaction gas. Namely, film formation and single crystallization progress at the same time. In the respective ones of the remaining positions "B" to "D", only supply of the reaction gas is carried out with progress of only film formation. Further, the directions of the substrates 11 are varied with the positions "A" to "D". When the substrates 11 successively itinerate the positions "A" to "D", therefore, it is possible to eliminate inhomogeneity in degree of film formation caused by inhomogeneity in a reaction system. Namely, it is possible to form a single-crystalline thin film having a uniform thickness on each substrate 11 also by employing this sample holder. Further, it is possible to regularly carry out irradiation with an atom current in the position "A". Therefore, it is possible to further efficiently form a single-crystalline thin film as compared with a case of employing the sample holder shown in Fig. 71.

(B-14. Twenty-sixth Preferred embodiment)

Fig. 73 is a front sectional view typically showing a sample holder which is provided in an apparatus for forming a single-crystalline thin film according to a twenty-sixth preferred embodiment of the present invention. In this sample holder, a reaction gas supply member 1412 defining a reaction gas supply path in its interior is rotatably mounted on a bottom portion of a treatment vessel 1402 while maintaining an airtight state. Therefore, this sample holder is suitably integrated in the apparatus 100 having no separate reaction gas supply system.

This reaction gas supply member 1412 is rotated/driven by a belt 1428. The reaction gas supply member 1412 is in a three layer structure provided with an inner pipe 1416 which is located on the innermost layer, an outer pipe 1414 which is located on the outermost layer, and an intermediate pipe 1418 which is located on the intermediate layer. Thus, the reaction gas supply member 1412 defines a supply path and an exhaust path for a reaction gas between the respective layers. Further, a reaction gas supply

port 1420 and a reaction gas discharge port 1426 are rotatably coupled to the reaction gas supply member 1412 through rotary seals 1430 and 1432 for maintaining airtightness respectively.

In addition, a support 1406 for fixedly supporting a sample fixing table 1404 is inserted in the interior of the reaction gas supply member 1412. A substrate 11 serving as a sample is placed on the sample fixing table 1404, while a heater 1408 for heating the sample is provided on a bottom surface of the sample fixing table 1404. This heater 1408 may be rotated at need, in order to improve temperature distribution on the substrate 11. The sample fixing table 1404 is so fixed that the same is not rotated following rotation of the reaction gas supply member 1412.

A reaction gas which is supplied from the reaction gas supply port 1420 passes through the supply path defined between the intermediate pipe 1418 and the inner pipe 1416, to be sprayed toward the upper surface of the substrate 11 from a reaction gas spray port 1422. A reacted residual gas enters another path which is defined between the outer pipe 1414 and the intermediate pipe 1417, i.e., the exhaust path from a reaction gas collection port 1424, and further passes this exhaust path to be discharged to the exterior from the reaction gas discharge port 1426. It is possible to homogeneously grow a prescribed thin film on the substrate 11 by rotating the reaction gas supply member 1412. Further, it is possible to continue the growth without interrupting irradiation with an atom current, since the substrate 11 is not rotated. Namely, it is possible to homogeneously form a film without interrupting single crystallization caused by irradiation with an atom current in this sample holder. Thus, it is possible to further efficiently form a single-crystalline thin film of a uniform thickness on the substrate 11.

(B-15. Twenty-seventh Preferred embodiment)

Fig. 74 is a front sectional view typically showing the structure of an apparatus for forming a single-crystalline thin film according to a twenty-seventh preferred embodiment of the present invention. This apparatus comprises two ECR ion sources 1204a and 1204b, similarly to the apparatus shown in Fig. 69. The feature of the apparatus according to this preferred embodiment resides in provision of control unit portions 1502 and 1504 for independently adjusting density levels of ion beams generated from the two ECR ion sources 1204a and 1204b. These control unit portions 1502 and 1504 separately, i.e., independently control the outputs of the two ECR ion sources 1204a and 1204b, whereby it is possible to easily optimize density levels of the ion beams supplied from the same. Thus, it is possible to stably form a high-quality single-crystalline thin film on the substrate 11.

(B-16. Twenty-eighth Preferred embodiment)

Fig. 75 is a front sectional view typically showing the structure of an apparatus for forming a single-crystalline thin film according to a twenty-eighth preferred embodiment of the present invention. This apparatus also comprises two ECR ion sources 1204a and 1204b, similarly to the apparatus shown in Fig. 74. The feature of the apparatus according to this preferred embodiment resides in that a bias voltage is applied across the two ECR ion sources 1204a and 1204b and a substrate 11, in a direction for accelerating ions. Namely, a dc voltage supply circuit is interposed in parallel in a series circuit of an RF power source 1602 for generating a high frequency and a matching circuit 1604 for ensuring impedance matching, i.e., a circuit for supplying a high frequency to the ECR ion sources 1204a and 1204b. The dc voltage supply circuit is formed by a series circuit of a dc power source 1606 and an inductor 1608 for blocking a high frequency.

Supply of the high frequency and that of the dc voltage are allotted to the two ECR ion sources 1204a and 1204b by time sharing through action of a switching relay 1610. These are alternately supplied to the two ECR ion sources 1204a and 1204b by time sharing, in order to prevent disturbance of a normal flow of an ion current caused by interference of dc voltages applied thereto.

In the apparatus according to this preferred embodiment, a bias voltage is applied across the ECR ion sources 1204a and 1204b and the substrate 11 in a direction for accelerating ions, whereby the atom current is advantageously improved in directivity. A similar effect is attained also when the bias voltage is simultaneously supplied to the two ECR ion sources 1204a and 1204b in place of the alternate supply by time sharing. Alternatively, two dc voltage supply circuits may be provided to independently supply bias voltages to the two ECR ion sources 1204a and 1204b respectively. In this case, it is possible to apply optimum bias voltages to the respective ECR ion sources 1204a and 1204b, whereby optimum irradiation conditions can be obtained.

(B-17. Twenty-ninth Preferred embodiment)

Fig. 76 is a front sectional view typically showing the structure of an apparatus for forming a single-crystalline thin film according to a twenty-ninth preferred embodiment of the present invention. This apparatus also comprises two ECR ion sources 1204a and 1204b, similarly to the apparatus shown in Fig. 75. The feature of the apparatus according to this preferred embodiment resides in that grids 1702 and 1704 to which bias voltages for adjusting ion extracting conditions are applied are provided in the vicinity of ion outlet ports of the two ECR ion sources 1204a and 1204b. Dc power sources 1706 and 1708 are interposed between the grids 1702 and 1704 and a substrate 11 respectively. The two grids 1702 and 1704 are separated from each other, so that the voltages applied thereto can be adjusted independently of each other.

When bias voltages are applied across the grids 1702 and 1704 and the substrate 11 in directions for accelerating ions, for example, an atom current is improved in directivity. In this apparatus, further, the levels of the bias voltages which are applied to the two grids 1702 and 1704 can be adjusted independently of each other, whereby it is possible to apply optimum bias voltages in response to operating states of the two ECR ion sources 1204a and 1204b. Thus, it is possible to efficiently form a high-quality single-crystalline thin film on the substrate 11.

While the invention has been shown and described in detail, the foregoing description is in all aspects illustrative and not restrictive. It is therefore understood that numerous modifications and variations can be devised without departing from the scope of the invention.

#### Claims

1. A method of forming a single-crystalline thin film, being adapted to form a single-crystalline thin film of a prescribed material on a substrate, by previously forming an amorphous thin film or a polycrystalline thin film of said prescribed material on said substrate and irradiating said amorphous thin film or said polycrystalline thin film with beams of neutral atoms or neutral molecules of low energy levels causing no sputtering of said prescribed material under a high temperature of not more than a crystallization temperature of said prescribed material from directions being perpendicular to a plurality of densest crystal planes, having different directions, in said single-crystalline thin film to be formed.
2. A method of forming a single-crystalline thin film in accordance with claim 1, wherein the atomic weights of atoms forming said beams are lower than the maximum one of the atomic weights of elements forming said prescribed material.
3. A method of forming a single-crystalline thin film in accordance with claim 1, wherein said beams are obtained by a single electron cyclotron resonance type ion generation source and a reflector being arranged in a path between said ion generation source and said amorphous thin film or said polycrystalline thin film.
4. A method of forming a single-crystalline thin film of a prescribed material on a polycrystalline substrate or an amorphous substrate using plasma chemical vapor deposition by supplying a reaction gas onto said substrate under a low temperature allowing no crystallization of said prescribed material with said plasma chemical vapor deposition alone while simultaneously irradiating said substrate with beams of a low energy gas causing no sputtering of said prescribed material from directions being perpendicular to a plurality of densest crystal planes having different directions in said single-crystalline thin film to be formed.
5. A method of forming a single-crystalline thin film in accordance with claim 4, wherein said gas is an inert gas.
6. A method of forming a single-crystalline thin film in accordance with claim 5, wherein the atomic weight of an element forming said inert gas is lower than the maximum one of the atomic weights of elements forming said prescribed material.
7. A method of forming a single-crystalline thin film in accordance with claim 4, wherein said prescribed material contains an element forming a gas material being in a gas state under ordinary temperatures, said beams of said gas being those of said gas material.



8. A method of forming a single-crystalline thin film in accordance with claim 4, wherein said reaction gas contains a reaction gas material being formed by an impurity element to be added to said prescribed material.
- 5 9. A method of forming a single-crystalline thin film in accordance with claim 8, wherein a plurality of types of said impurity elements are so employed that a plurality of types of reaction gas materials being formed by respective ones of said plurality of types of impurity elements are alternately supplied onto said substrate.
- 10 10. A method of forming a single-crystalline thin film in accordance with claim 4, wherein said beams of said gas are obtained by a single beam source and a reflector being arranged in a path between said beam source and said substrate.
11. A method of forming a single-crystalline thin film in accordance with claim 10, wherein said beam source is an ion generation source generating an ion beam of said gas, and said reflector is a metal reflector being substantially made of a metal.
- 15 12. A method of forming a single-crystalline thin film in accordance with claim 10, wherein said beam source is an electron cyclotron resonance type ion generation source.
- 20 13. A beam irradiator for irradiating a target surface of a sample with a gas beam, said beam irradiator comprising:  
a container for storing said sample; and  
a beam source for irradiating said target surface of said sample being set in a prescribed position  
25 of said container with said gas beam,  
at least a surface of a portion irradiated with said beam being made of a material having threshold energy being higher than energy of said beam in sputtering by irradiation with said beam among an inner wall of said container and a member being stored in said container.
- 30 14. A beam irradiator for irradiating a target surface of a sample with a gas beam, said beam irradiator comprising:  
a container for storing said sample; and  
a beam source for irradiating said target surface of said sample being set in a prescribed position  
35 of said container with said gas beam,  
at least a surface of a portion irradiated with said beam being made of a material having threshold energy with respect to sputtering being higher than that in said target surface of said sample among an inner wall of said container and a member being stored in said container.
- 40 15. A beam irradiator for irradiating a target surface of a sample with a gas beam, said beam irradiator comprising:  
a container for storing said sample; and  
a beam source for irradiating said target surface of said sample being set in a prescribed position  
45 of said container with said gas beam,  
at least a surface of a portion irradiated with said beam being made of a material containing an element being larger in atomic weight than that forming said gas among an inner wall of said container and a member being stored in said container.
- 50 16. A beam irradiator for irradiating a target surface of a sample with a gas beam, said beam irradiator comprising:  
a container for storing said sample; and  
a beam source for irradiating said target surface of said sample being set in a prescribed position  
55 of said container with said gas beam,  
at least a surface of a portion irradiated with said beam being made of the same material as that forming said target surface of said sample among an inner wall of said container and a member being stored in said container.
17. A beam irradiator in accordance with any of claims 13 to 16, wherein said member being stored in said container includes reflecting means being interposed in a path of said beam for separating said beam

into a plurality of components and irradiating said target surface of said sample with said plurality of components from directions being different from each other.

- 5 18. A beam irradiating method of irradiating a target surface of a sample with a gas beam, said method comprising:
- a step of setting said sample in a prescribed position of a container; and
  - a step of irradiating said target surface of said sample being set in said container with said gas beam,
- 10 said target surface being irradiated with said beam at energy being lower than threshold energy of sputtering in a surface of a portion being irradiated with said beam among an inner wall of said container and a member being stored in said container.
19. A method of forming a single-crystalline thin film, being adapted to form a single-crystalline thin film of a prescribed material on a substrate, said method comprising:
- 15 a step of depositing said prescribed material on said substrate under a low temperature causing no crystallization of said prescribed material and irradiating said prescribed material being deposited with a gas beam of low energy causing no sputtering of said prescribed material from one direction, thereby forming an axially oriented polycrystalline thin film of said material; and
- 20 a step of irradiating said axially oriented polycrystalline thin film with gas beams of low energy causing no sputtering of said prescribed material under a high temperature below a crystallization temperature of said prescribed material from directions being perpendicular to a plurality of densest crystal planes of different directions in said single-crystalline thin film, thereby converting said axially oriented polycrystalline thin film to a single-crystalline thin film.
- 25 20. A method of forming a single-crystalline thin film, being adapted to form a single-crystalline thin film of a prescribed material on a substrate, said method comprising:
- a step of depositing said prescribed material on said substrate thereby forming a thin film of said material;
  - a step of irradiating said thin film with a gas beam of low energy causing no sputtering of said prescribed material under a high temperature below a crystallization temperature of said prescribed material from one direction after said step, thereby converting said thin film to an axially oriented polycrystalline thin film; and
  - a step of irradiating said axially oriented polycrystalline thin film with gas beams of low energy causing no sputtering of said prescribed material under a high temperature below said crystallization temperature of said prescribed material from directions being perpendicular to a plurality of densest crystal planes of different directions in said single-crystalline thin film, thereby converting said axially oriented polycrystalline thin film to a single-crystalline thin film.
- 30 35
- 40 21. A method of forming a single-crystalline thin film in accordance with claim 19 or 20, wherein said direction of said gas beam in formation of said axially oriented polycrystalline thin film is identical to one of said plurality of directions of said gas beams in said conversion of said axially oriented polycrystalline thin film to said single-crystalline thin film.
- 45 22. A method of forming a single-crystalline thin film in accordance with claim 19 or 20, wherein said gas is an inert gas.
- 50 23. A method of forming a single-crystalline thin film in accordance with claim 22, wherein the atomic weight of an element forming said inert gas is lower than the maximum atomic weight among those of elements forming said prescribed material.
24. A method of forming a single-crystalline thin film in accordance with claim 19 or 20, wherein said prescribed material contains an element forming a gas material being a gas under a normal temperature, said gas beam being a beam of said gas material.
- 55 25. A method of forming a single-crystalline thin film in accordance with claim 19 or 20, wherein said gas beam is formed by an electron cyclotron resonance ion source.

26. A beam irradiator for irradiating a target surface of a sample with a gas beam, said beam irradiator comprising:  
 a single beam source for supplying said beam; and  
 reflecting means for reflecting said beam being supplied by said beam source, thereby enabling  
 5 irradiation of said target surface with said gas in a plurality of prescribed directions of incidence,  
 said reflecting means comprising a reflector having a plurality of reflecting surfaces for reflecting  
 said beam in a plurality of directions, and a screen being interposed in a path of said beam between  
 said beam source and said reflecting surfaces for selectively passing said beam thereby preventing  
 multiple reflection by said plurality of reflecting surfaces.  
 10
27. A beam irradiator in accordance with claim 26, wherein said screen further selectively passes said  
 beam to uniformly irradiate said target surface with said beam.
28. A beam reflecting device for reflecting a gas beam being supplied from a single beam source thereby  
 15 enabling irradiation of a target surface of a sample with said gas in a plurality of prescribed directions  
 of incidence, said beam reflecting device comprising:  
 a reflector having a plurality of reflecting surfaces for reflecting said beam in a plurality of  
 directions; and  
 a screen being interposed in a path of said beam between said beam source and said reflecting  
 20 surfaces for selectively passing said beam thereby preventing multiple reflection by said plurality of  
 reflecting surfaces.
29. A beam reflecting device in accordance with claim 28, wherein said screen further selectively passes  
 said beam to uniformly irradiate said target surface with said beam.  
 25
30. A beam irradiator for irradiating a target surface of a sample with a gas beam, said beam irradiator  
 comprising:  
 a single beam source for supplying said beam; and  
 reflecting means for reflecting said beam being supplied by said beam source, thereby enabling  
 30 irradiation of said target surface with said gas in a plurality of prescribed directions of incidence,  
 said reflecting means comprising a first reflector being arranged in a path of said beam being  
 supplied from said beam source for reflecting said beam in a plurality of directions thereby generating  
 a plurality of divergent beams having beam sections being two-dimensionally enlarged with progress of  
 said beams, and a second reflector having a concave reflecting surface for further reflecting said  
 35 plurality of divergent beams to be incident upon said target surface substantially as parallel beams from  
 a plurality of directions.
31. A beam irradiator in accordance with claim 30, wherein said reflecting means further comprises  
 40 rectifying means being provided in a path of said beams between said first reflector and said substrate  
 for regularizing directions of said beams.
32. A beam irradiator in accordance with claim 30, wherein said reflecting means further comprises beam  
 distribution adjusting means being interposed in a path of said beam between said beam source and  
 said first reflector for adjusting distribution of said beam on a section being perpendicular to said path,  
 45 thereby adjusting the amounts of respective beam components being reflected by said first reflector in  
 said plurality of directions.
33. A beam reflecting device for reflecting a gas beam being supplied from a single beam source thereby  
 50 enabling irradiation of a target surface of a sample with said gas in a plurality of prescribed directions  
 of incidence, said beam reflecting device comprising:  
 a first reflector for reflecting said beam in a plurality of directions thereby generating a plurality of  
 divergent beams having beam sections being two-dimensionally enlarged with progress of said beams;  
 and  
 a second reflector having a concave reflecting surface for further reflecting said plurality of  
 55 divergent beams to be incident upon said target surface substantially as parallel beams from a plurality  
 of directions.

34. A beam irradiator for irradiating a target surface of a sample with gas beams, said beam irradiator comprising:  
 a plurality of beam sources for supplying said gas beams; and  
 a plurality of reflecting means for reflecting said beams being supplied by said plurality of beam sources thereby enabling irradiation of a common region of said target surface with said gas in a plurality of prescribed directions of incidence,  
 each said reflecting means comprising a first reflector being arranged in a path of each said beam being supplied from each said beam source for reflecting said beam thereby generating a beam having a beam section being two-dimensionally enlarged with progress of said beam, and a second reflector having a concave reflecting surface for further reflecting said divergent beam to be incident upon linear or strip-shaped said common region of said target surface substantially as a parallel beam,  
 said beam irradiator further comprising moving means for scanning said sample in a direction intersecting with linear or strip-shaped said common region.
35. A beam irradiator in accordance with claim 34, wherein each said reflecting means further comprises rectifying means being provided in a path of each said beam between said first reflector and said substrate for regulating the direction of said beam.
36. A beam reflecting device for reflecting a gas beam being supplied from a beam source thereby enabling irradiation of a target surface of a sample with said gas in a prescribed direction of incidence, said beam reflecting device comprising:  
 a first reflector for reflecting said beam thereby generating a divergent beam having a beam section being two-dimensionally enlarged with progress of said beam; and  
 a second reflector having a concave reflecting surface for further reflecting said divergent beam to be incident upon a linear or strip-shaped region of said target surface substantially as a parallel beam.
37. A method of forming a single-crystalline thin film of a prescribed material, comprising:  
 (a) a step of forming an amorphous or polycrystalline thin film of said prescribed material on a substrate;  
 (b) a step of forming a masking material on said thin film;  
 (c) a step of selectively removing said masking material; and  
 (d) a step of irradiating said substrate with gas beams of low energy levels causing no sputtering of said prescribed material from directions being perpendicular to a plurality of densest crystal planes having different directions in said single-crystalline thin film to be formed while utilizing selectively removed said masking material as a screen under a high temperature below the crystallization temperature of said prescribed material.
38. A method of forming a single-crystalline thin film in accordance with claim 37, wherein said steps (b) to (d) are carried out plural times while varying directions for applying said beams in said step (d), thereby selectively converting said thin film to a single crystal having a plurality of types of crystal orientations.
39. A method of forming a single-crystalline thin film of a prescribed material, comprising:  
 (a) a step of forming an amorphous or polycrystalline thin film of said prescribed material on a substrate;  
 (b) a step of forming a masking material on said thin film;  
 (c) a step of selectively removing said masking material;  
 (d) a step of etching said thin film while utilizing selectively removed said masking material as a screen, thereby selectively removing said thin film while leaving a specific region on said substrate; and  
 (e) a step of irradiating said substrate with gas beams of low energy levels causing no sputtering of said prescribed material from directions being perpendicular to a plurality of densest crystal planes having different directions in said single-crystalline thin film to be formed under a high temperature below the crystallization temperature of said prescribed material.
40. A method of forming a single-crystalline thin film of a prescribed material, comprising:  
 (a) a step of forming an amorphous or polycrystalline thin film of said prescribed material on a substrate;

- (b) a step of irradiating said substrate with gas beams of low energy levels causing no sputtering of said prescribed material from directions being perpendicular to a plurality of densest crystal planes having different directions in said single-crystalline thin film to be formed under a high temperature below the crystallization temperature of said prescribed material;
- 5 (c) a step of forming a masking material on said thin film after said step (b);  
(d) a step of selectively removing said masking material; and  
(e) a step of etching said thin film while utilizing selectively removed said masking material as a screen, thereby selectively removing said thin film.
- 10 41. A method of forming a single-crystalline thin film of a prescribed material, comprising:  
(a) a step of forming an amorphous or polycrystalline thin film of said prescribed material on a substrate;  
(b) a step of irradiating said substrate with gas beams of low energy levels causing no sputtering of said prescribed material from directions being perpendicular to a plurality of densest crystal planes having different directions in said single-crystalline thin film to be formed under a low temperature causing no crystallization of said prescribed material by said step (a) alone while carrying out said step (a);
- 15 (c) a step of forming a masking material on said thin film after said steps (a) and (b);  
(d) a step of selectively removing said masking material; and  
(e) a step of etching said thin film while utilizing selectively removed said masking material as a screen, thereby selectively removing said thin film.
- 20 42. A method of forming a single-crystalline thin film of a prescribed material, comprising:  
(a) a step of forming an amorphous or polycrystalline thin film of said prescribed material on a substrate;
- 25 (b) a step of irradiating said substrate with gas beams of low energy levels causing no sputtering of said prescribed material from directions being perpendicular to a plurality of densest crystal planes having different directions in said single-crystalline thin film to be formed under a high temperature below the crystallization temperature of said prescribed material;
- 30 (c) a step of forming a masking material on said thin film after said step (b);  
(d) a step of selectively removing said masking material; and  
(e) a step of irradiating said substrate with said gas beams of low energy levels causing no sputtering of said prescribed material from directions being perpendicular to said plurality of densest crystal planes having different directions in said single-crystalline thin film to be formed, said directions being different from those in said step (b), while utilizing selectively removed said masking material as a screen.
- 35 43. An apparatus for forming a single-crystalline thin film of a prescribed material on a substrate, comprising:  
irradiation means for irradiating said substrate with gas beams of low energy levels causing no sputtering of said prescribed material from directions being perpendicular to a plurality of densest crystal planes having different directions in said single-crystalline thin film to be formed; and  
substrate moving means for making said substrate scanned with respect to said irradiation means.
- 40 44. An apparatus for forming a single-crystalline thin film in accordance with claim 43, further comprising beam focusing means for bringing sections of said gas beams into strip shapes on said substrate.
- 45 45. An apparatus for forming a single-crystalline thin film of a prescribed material on a substrate, comprising:  
a single beam source for supplying a beam of a gas;
- 50 a reflector for reflecting at least a part of said beam being supplied by said beam source, thereby implementing irradiation of said substrate with said gas in a plurality of prescribed directions of incidence; and  
reflector driving means for varying the angle of inclination of said reflector.
- 55 46. An apparatus for forming a single-crystalline thin film of a prescribed material on a substrate, comprising:  
a single beam source for supplying a beam of a gas;

a plurality of reflectors, each one of said plurality of reflectors reflecting at least a part of said beam being supplied by said beam source, thereby implementing irradiation of said substrate with said gas in a plurality of prescribed directions of incidence being related to the angle of inclination of said reflector; and

5 reflector exchange means for selecting a prescribed one from said plurality of reflectors and utilizing the same for reflecting said beam.

47. An apparatus for forming a single-crystalline thin film in accordance with claim 43, 45 or 46, further comprising film forming means for forming an amorphous or polycrystalline thin film of the same  
10 material as said single-crystalline thin film on said substrate.

48. An apparatus for forming a single-crystalline thin film of a prescribed material on a substrate, comprising:

etching means for etching a surface of said substrate;

15 film forming means for forming an amorphous or polycrystalline thin film of said prescribed material on said surface of said substrate; and

irradiation means for irradiating said substrate with gas beams of low energy levels causing no sputtering of said prescribed material from directions being perpendicular to a plurality of densest crystal planes having different directions in said single-crystalline thin film to be formed,

20 treatment chambers for storing said substrate in said means communicating with each other, said apparatus further comprising substrate carrying means for introducing and discharging said substrate into and from respective said treatment chambers.

49. An apparatus for forming a single-crystalline thin film of a prescribed material on a substrate having a  
25 single-crystalline structure, comprising:

irradiation means for irradiating said substrate with gas beams of low energy levels causing no sputtering of said prescribed material from directions being perpendicular to a plurality of densest crystal planes having different directions in said single-crystalline thin film to be formed; and

30 attitude control means for controlling the attitude of said substrate for setting prescribed relations between directions of crystal axes of said substrate and directions of incidence of said beams.

50. An apparatus for forming a single-crystalline thin film of a prescribed material on a substrate, comprising:

film forming means for forming an amorphous or polycrystalline thin film of said prescribed material  
35 on said substrate by supplying a reaction gas;

irradiation means for irradiating said substrate with gas beams of low energy levels causing no sputtering of said prescribed material from directions being perpendicular to a plurality of densest crystal planes having different directions in said single-crystalline thin film to be formed; and

substrate rotating means for rotating said substrate.

40 51. An apparatus for forming a single-crystalline thin film of a prescribed material on a substrate, comprising:

film forming means for forming an amorphous or polycrystalline thin film of said prescribed  
45 material on said substrate by supplying a reaction gas; and

irradiation means for irradiating said substrate with gas beams of low energy levels causing no sputtering of said prescribed material from directions being perpendicular to a plurality of densest crystal planes having different directions in said single-crystalline thin film to be formed,

50 said film forming means having supply system rotating means for rotating an end portion of a supply path for supplying said substrate with said reaction gas with respect to said substrate.

52. An apparatus for forming a single-crystalline thin film of a prescribed material on a substrate, comprising:

55 a plurality of irradiation means for irradiating said substrate with a plurality of gas beams of low energy levels causing no sputtering of said prescribed material from directions being perpendicular to a plurality of densest crystal planes having different directions in said single-crystalline thin film to be formed respectively; and

control means for independently controlling operating conditions in said plurality of irradiation

means respectively.

53. An apparatus for forming a single-crystalline thin film of a prescribed material on a substrate, comprising:

5 irradiation means for irradiating said substrate with beams of a gas being supplied by an ion source at low energy levels causing no sputtering of said prescribed material from directions being perpendicular to a plurality of densest crystal planes having different directions in said single-crystalline thin film to be formed; and

10 bias means for applying a bias voltage across said ion source and said substrate in a direction for accelerating ions.

54. An apparatus for forming a single-crystalline thin film of a prescribed material on a substrate, comprising:

15 irradiation means for irradiating said substrate with beams of a gas being supplied by an ion source at low energy levels causing no sputtering of said prescribed material from directions being perpendicular to a plurality of densest crystal planes having different directions in said single-crystalline thin film to be formed, a grid being provided in the vicinity of an ion outlet of said ion source; and

20 grid voltage applying means for applying a voltage to said grid for controlling conditions for extracting ions from said ion source.

55. A method of forming a single-crystalline thin film in accordance with any of claims 37 to 42, wherein the atomic weight of an element forming said gas is lower than the maximum one of the atomic weights of elements forming said prescribed material.

- 25 56. A method of forming a single-crystalline thin film in accordance with any of claims 37, 38 and 42, wherein the atomic weight of an element forming said gas is lower than the maximum one of the atomic weights of elements forming said masking material.

- 30 57. An apparatus for forming a single-crystalline thin film in accordance with any of claims 43 and 48 to 52, wherein said irradiation means comprises an electron cyclotron resonance type ion source, said gas beams being supplied by said ion source.

- 35 58. An apparatus for forming a single-crystalline thin film in accordance with claim 45 or 46, wherein said beam source is an electron cyclotron resonance type ion source.

59. An apparatus for forming a single-crystalline thin film in accordance with claim 53 or 54, wherein said beam source is an electron cyclotron resonance type ion source.

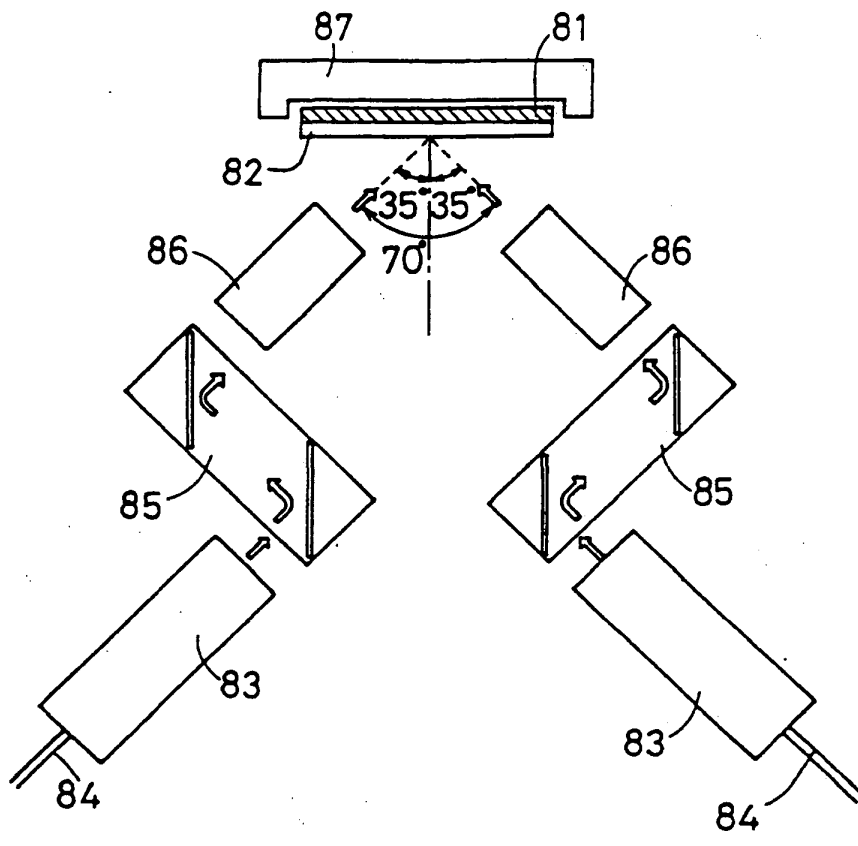
40

45

50

55

FIG. 1



80



FIG. 2A

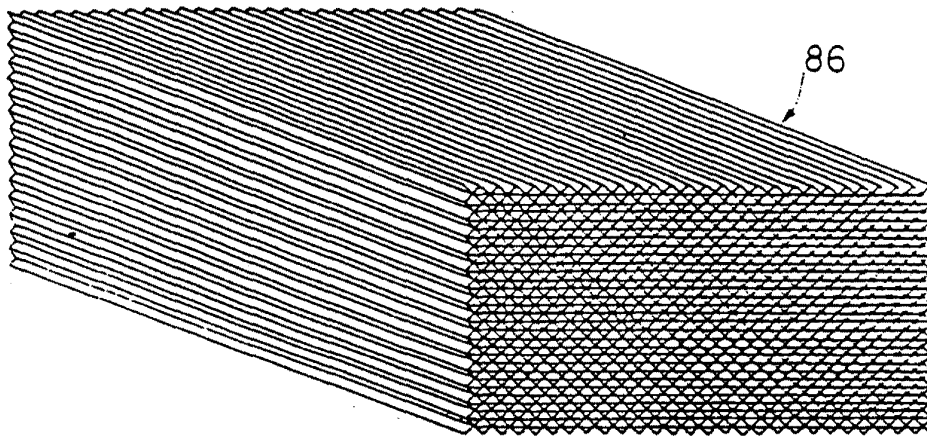


FIG. 2B

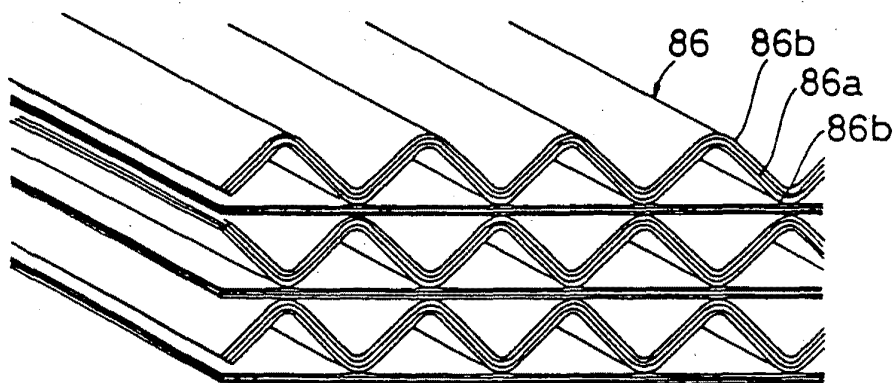


FIG. 2C

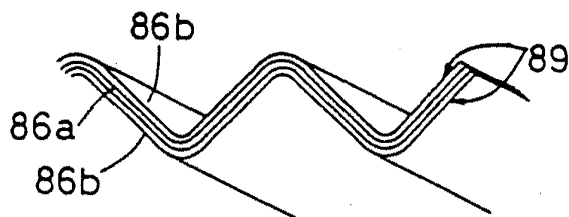


FIG. 3A

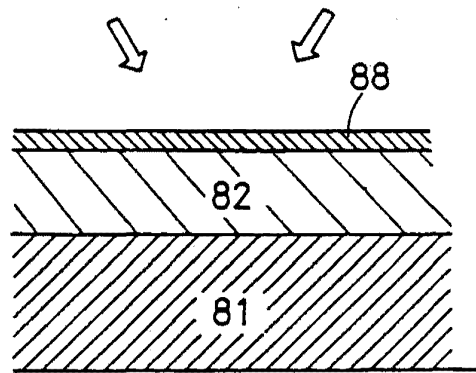
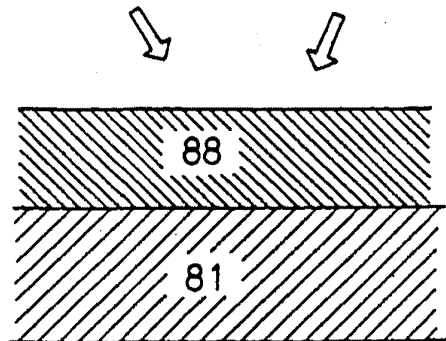


FIG. 3B



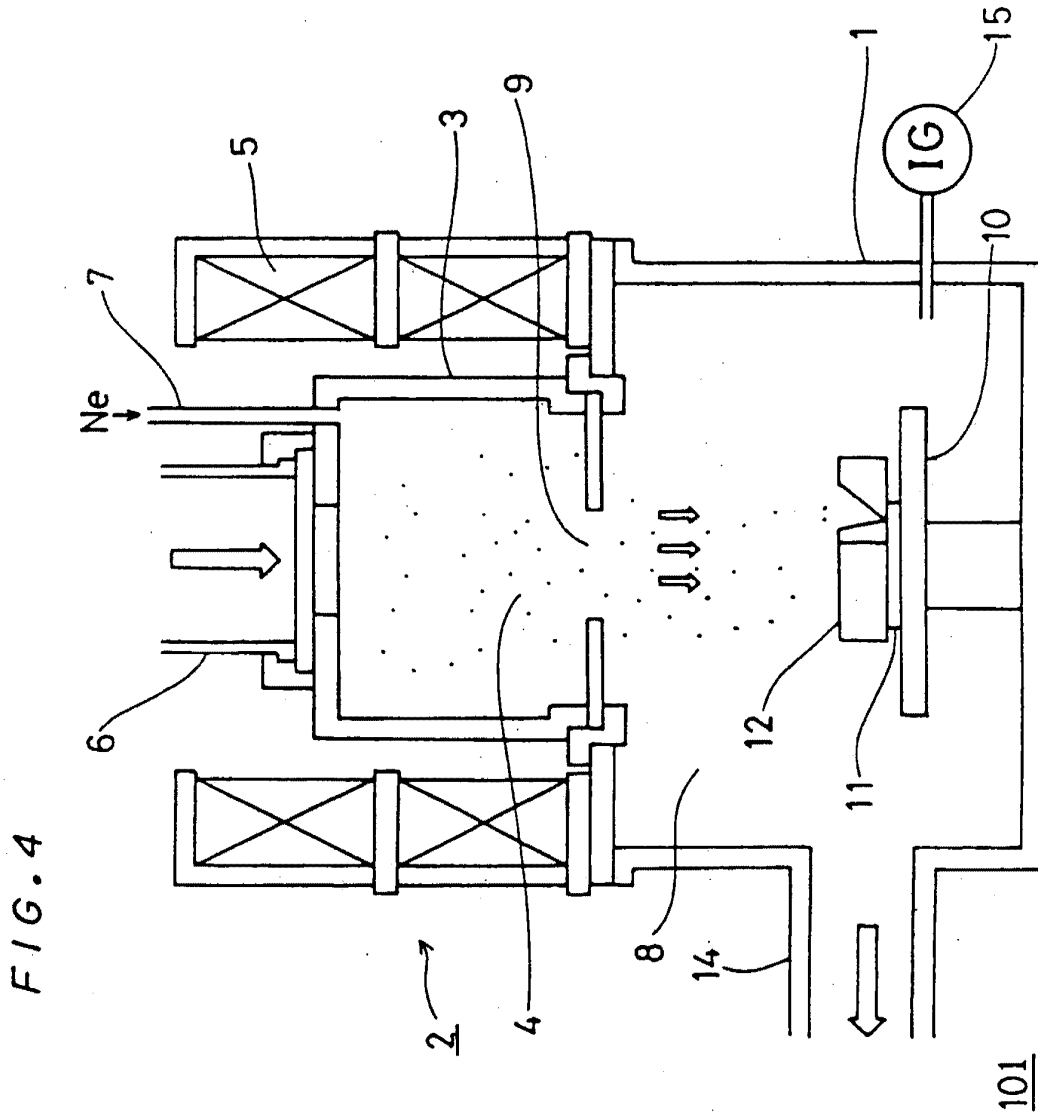
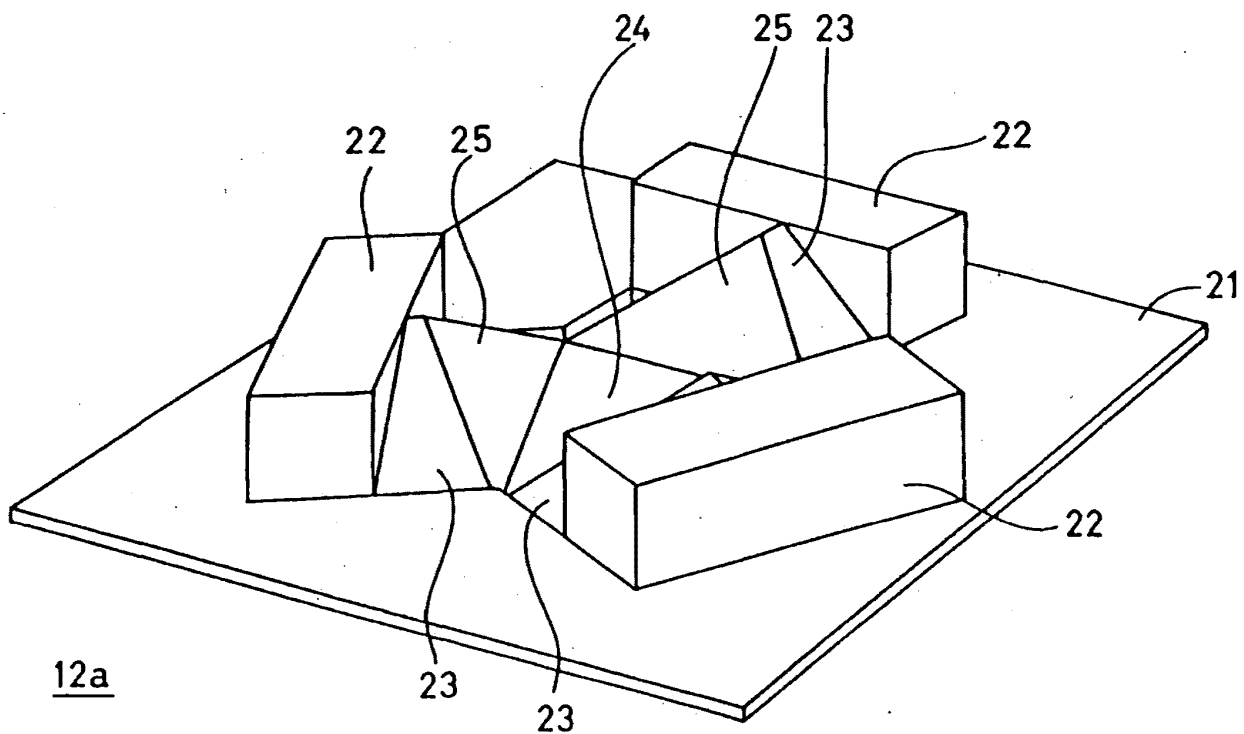


FIG. 5



62

EP 0 652 308 A2

FIG. 6A

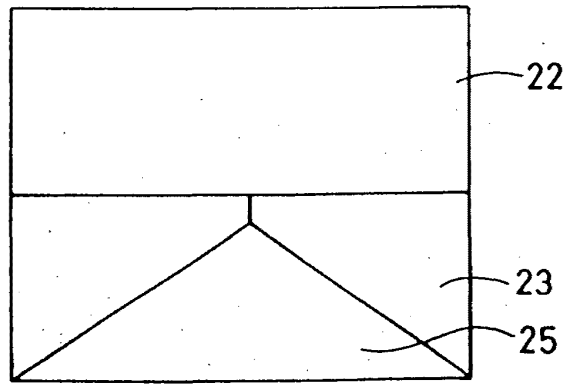
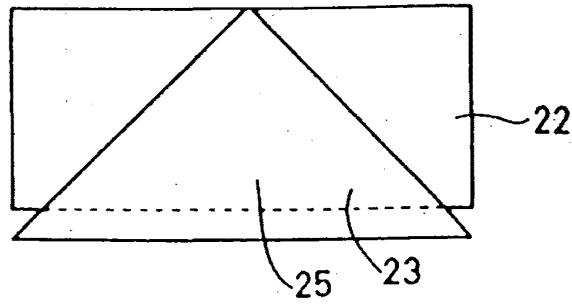


FIG. 6C



12a

FIG. 6B

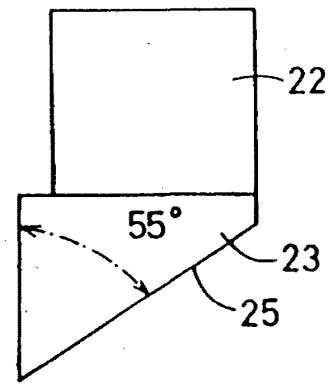


FIG. 7

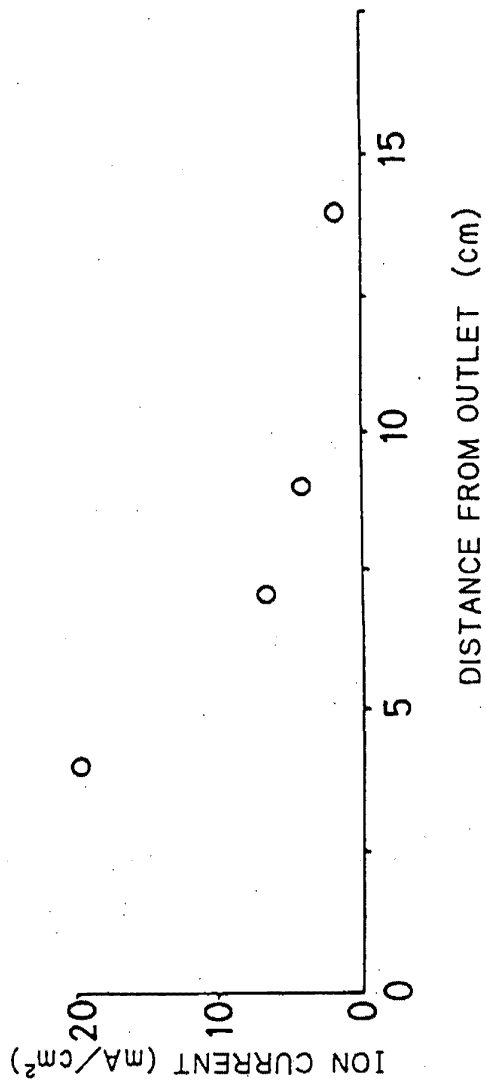


FIG. 8

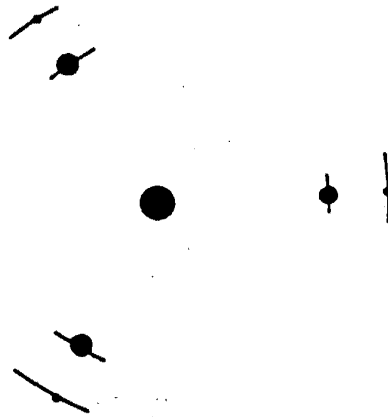
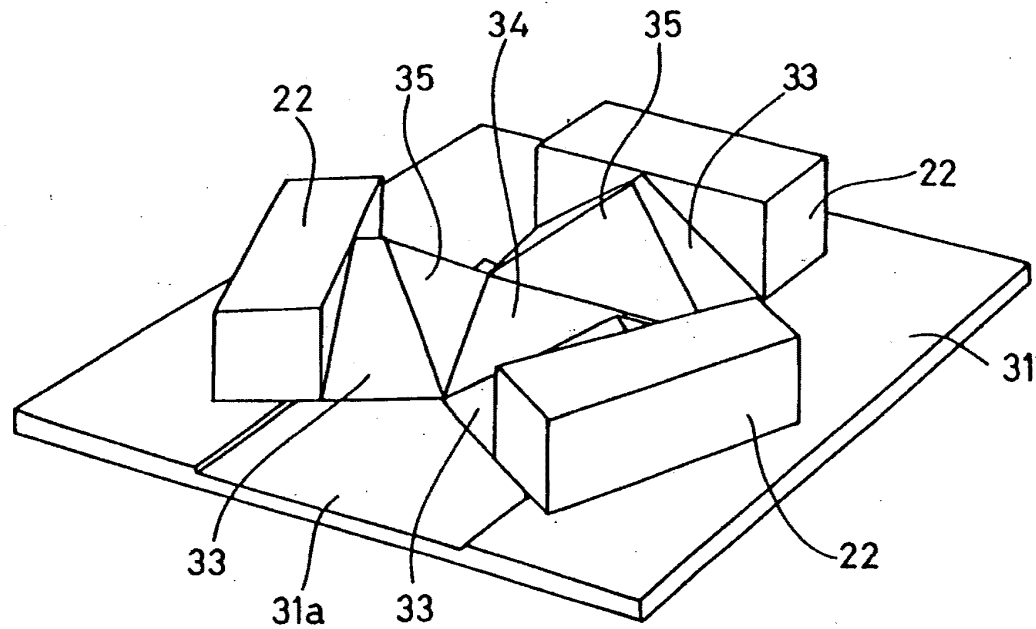


FIG. 9



12b



FIG. 10A

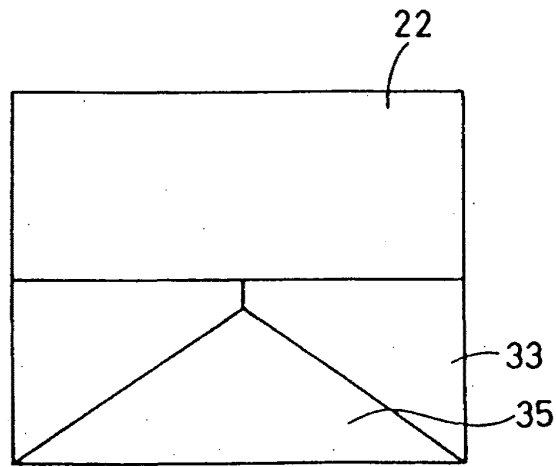


FIG. 10B

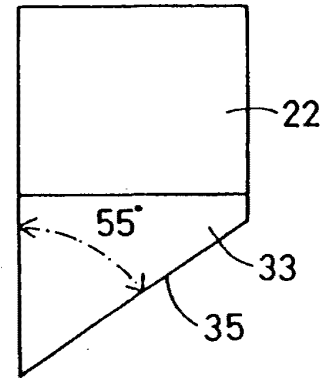
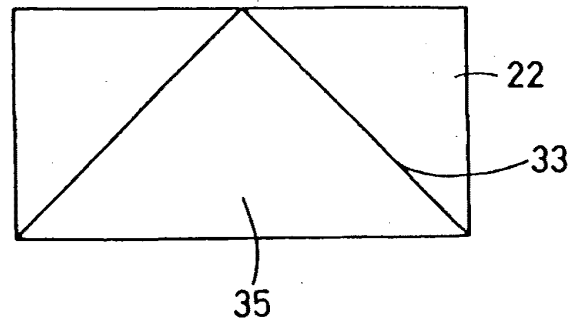


FIG. 10C



12b

FIG. 11A

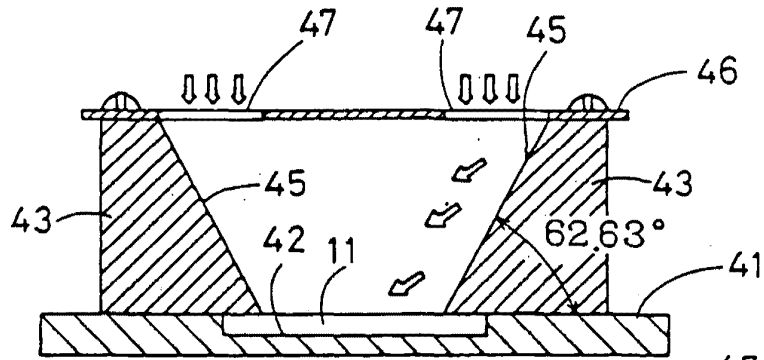
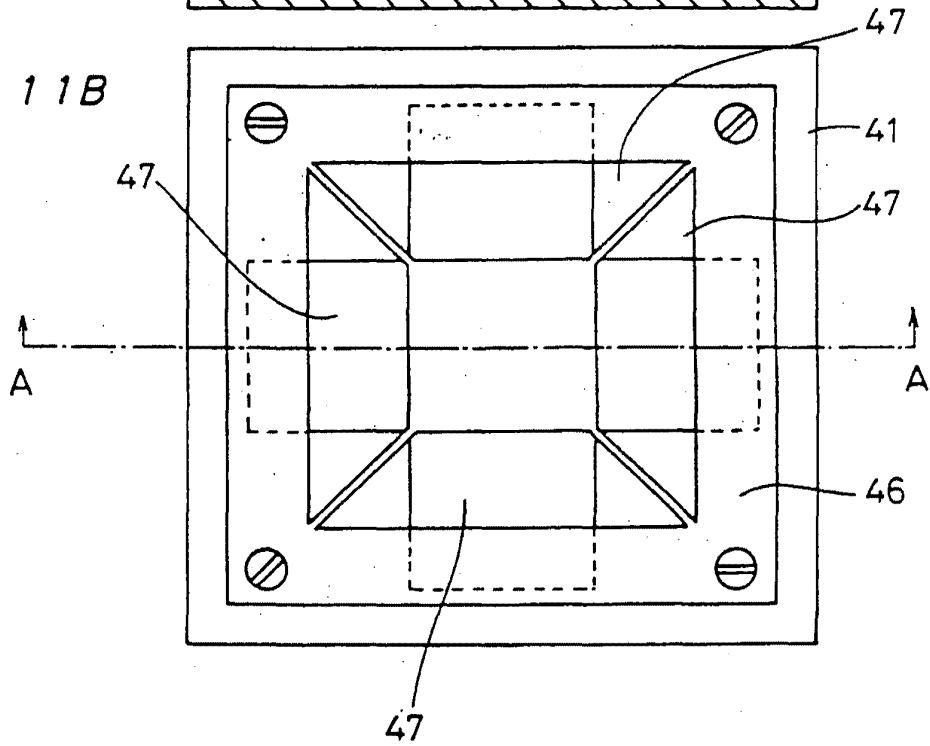
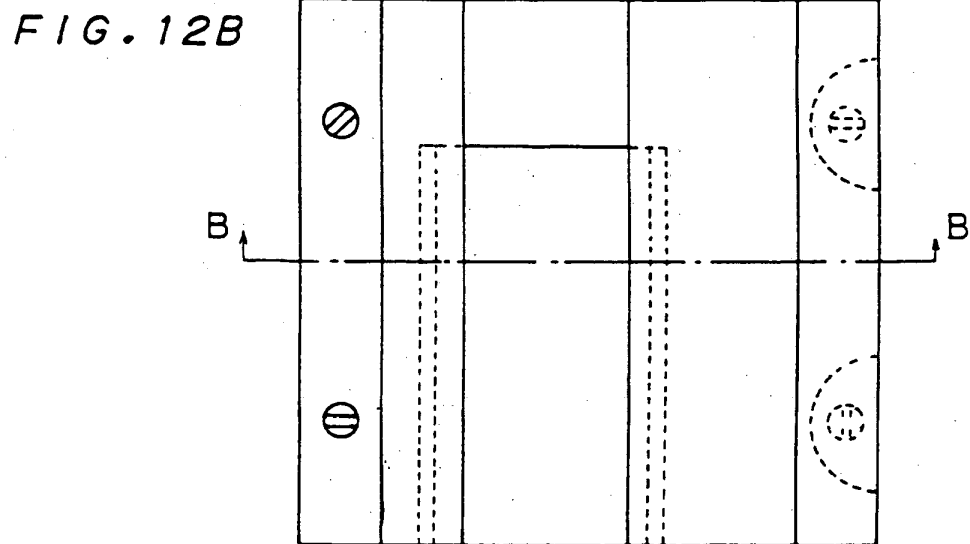
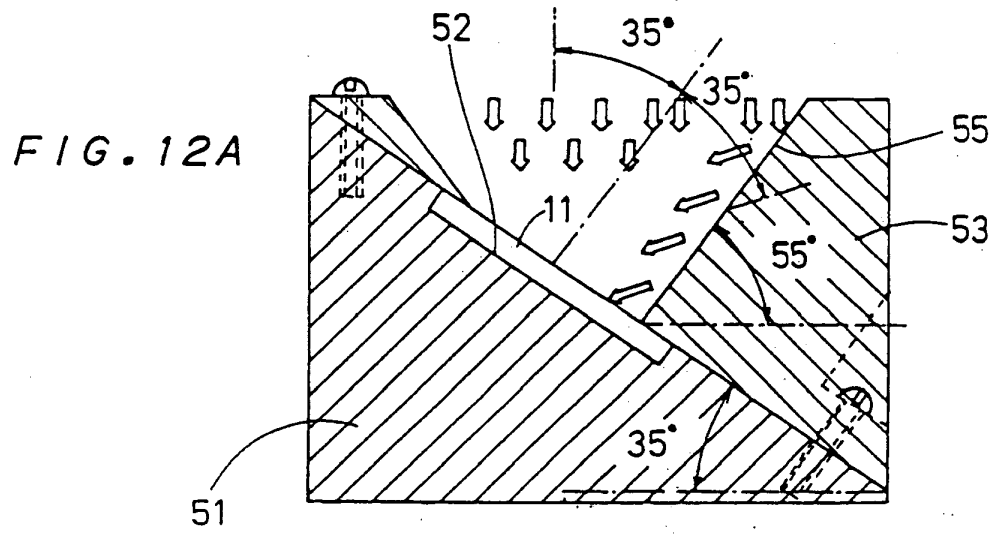


FIG. 11B

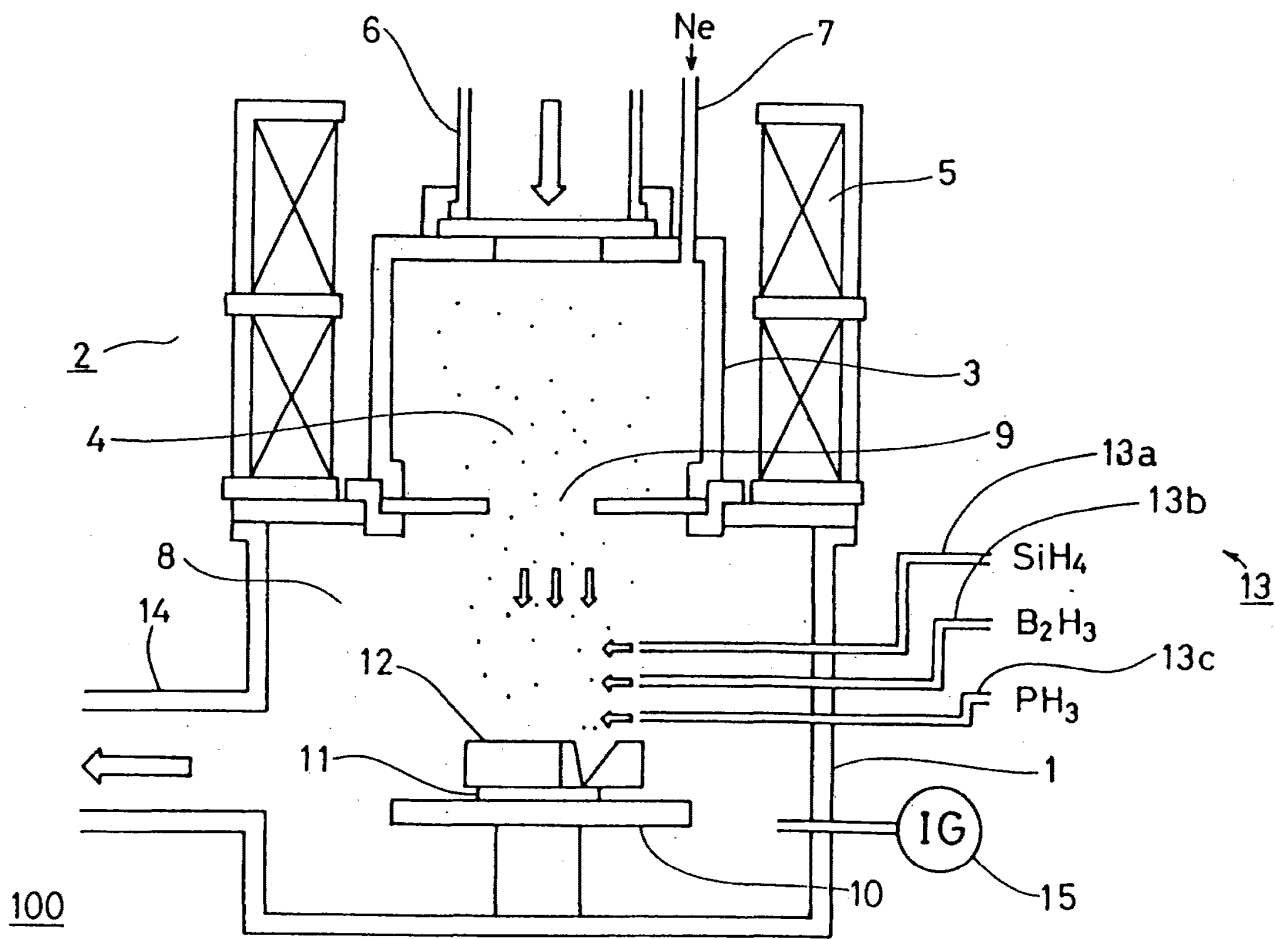


12c



12d

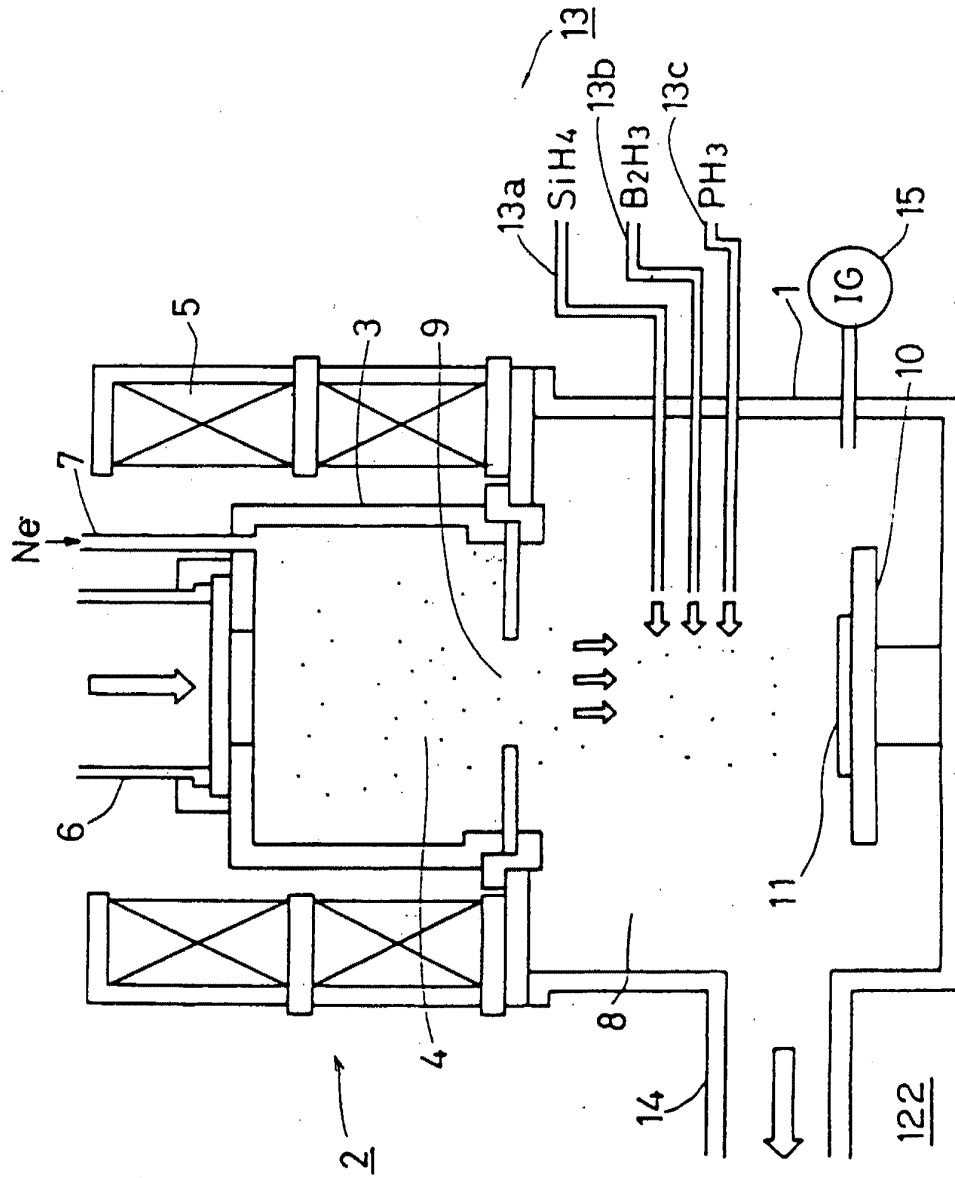
FIG. 13



70

EP 0 652 308 A2

FIG. 14



*FIG. 15*

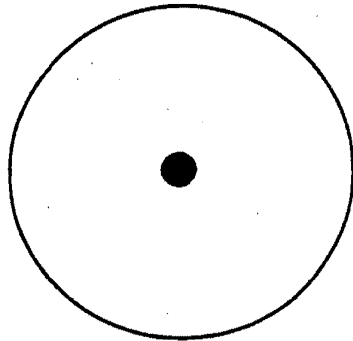
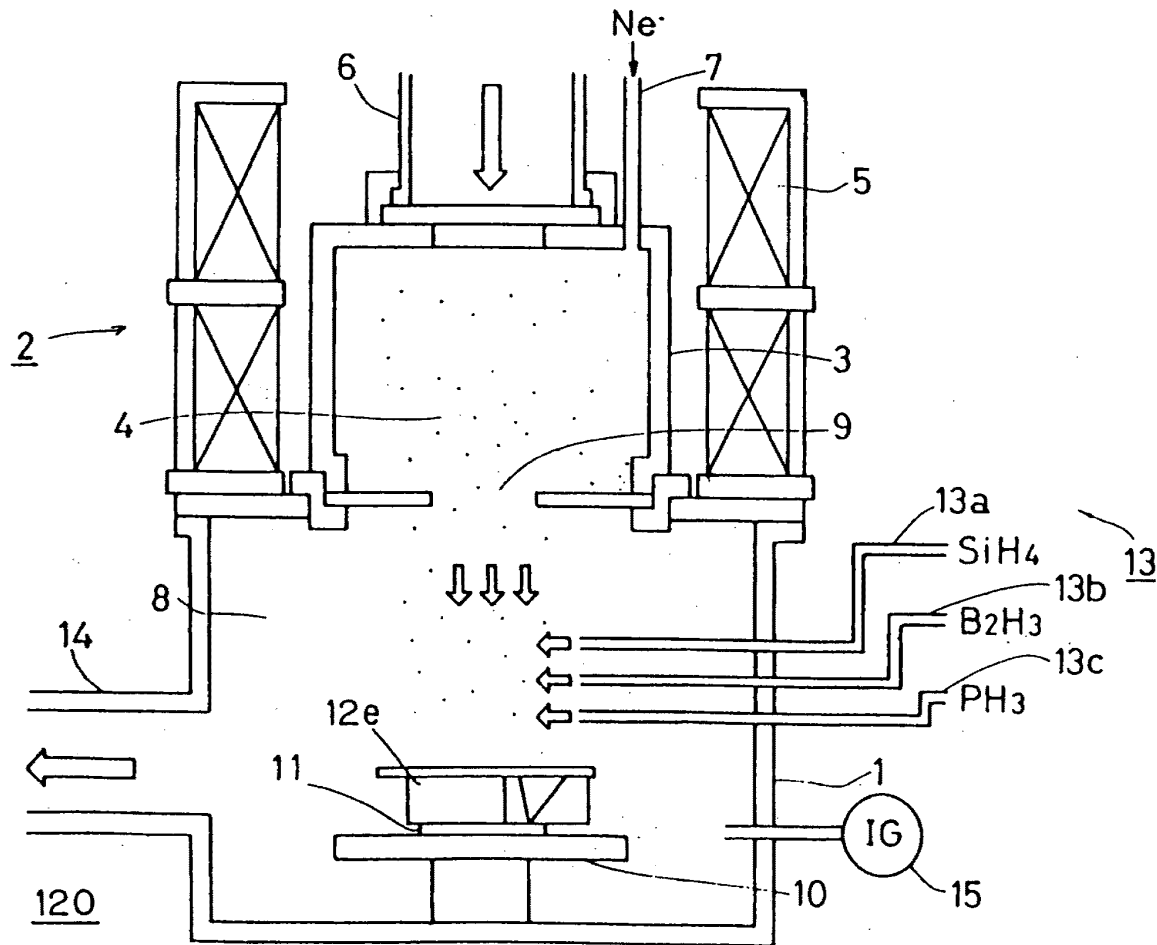


FIG. 16



EP 0 652 308 A2

FIG. 17

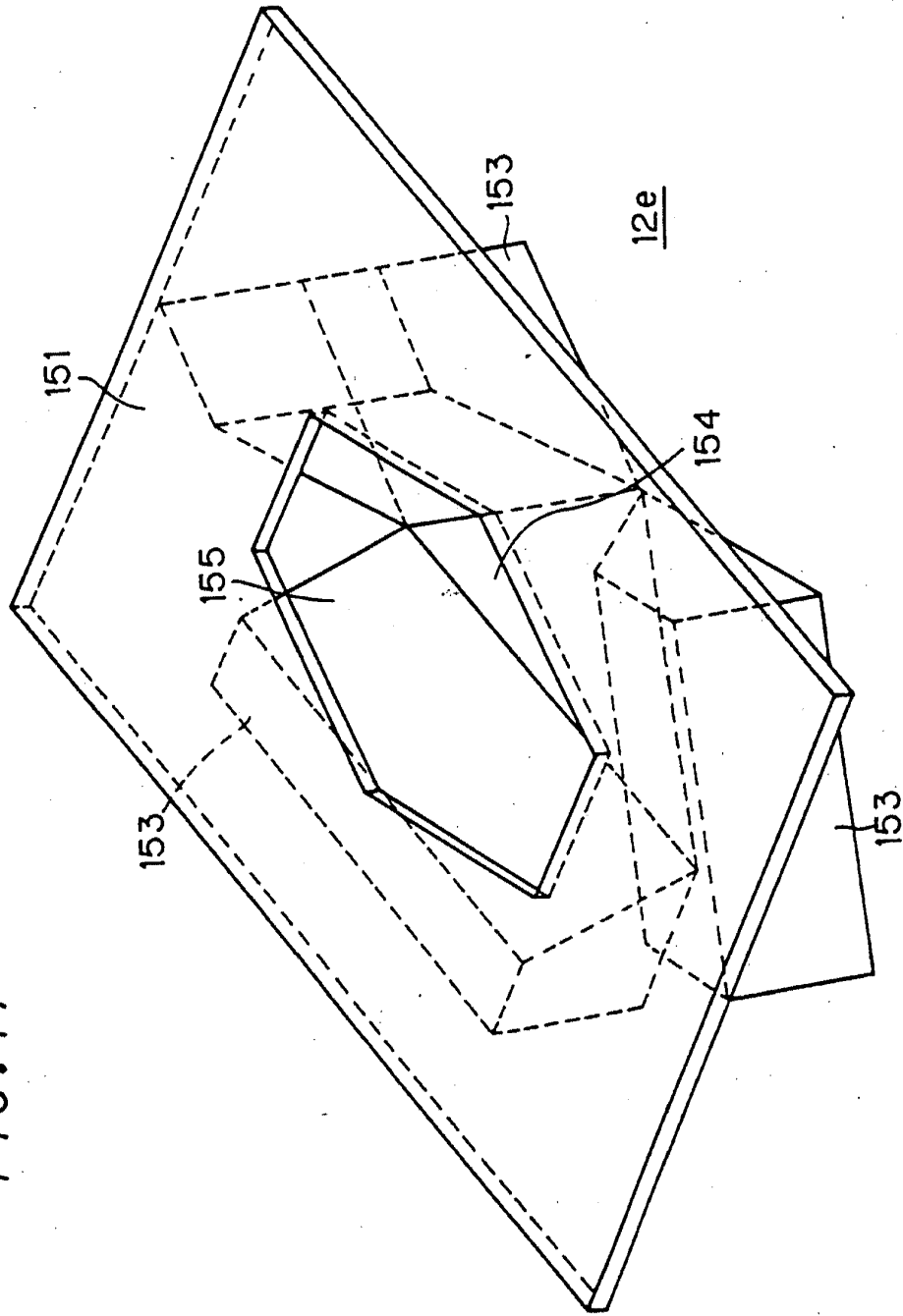




FIG. 18

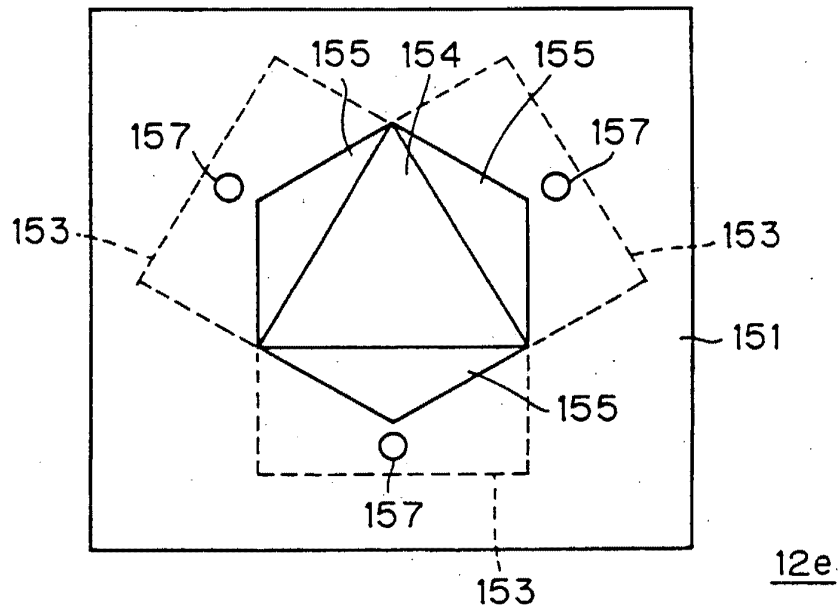


FIG. 19

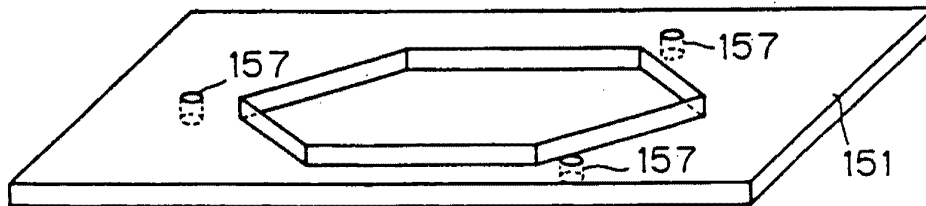


FIG. 20

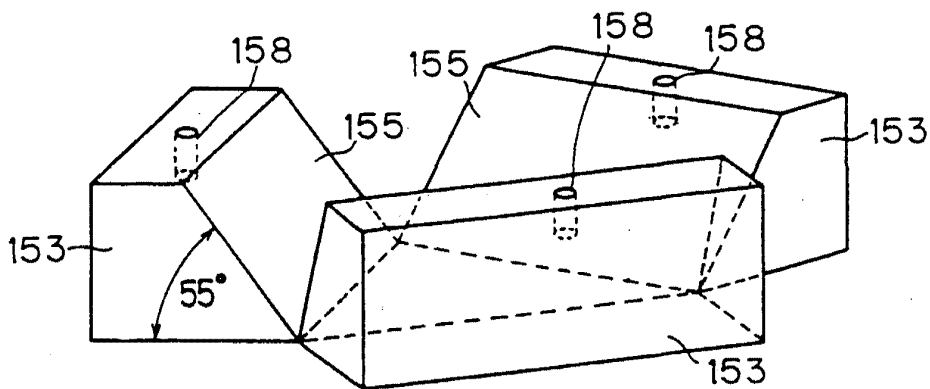


FIG. 21

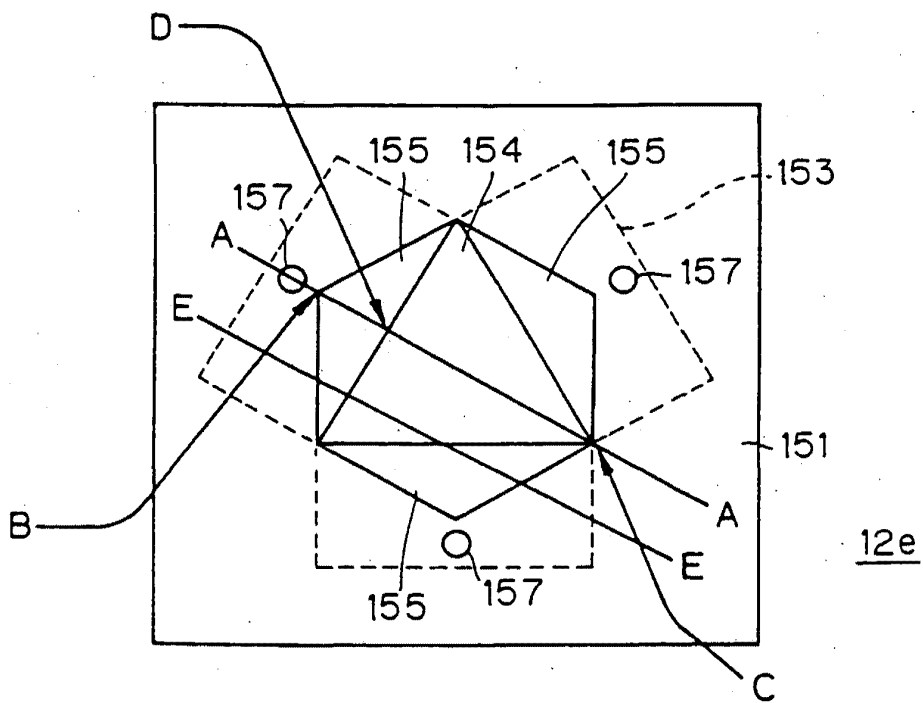


FIG. 22

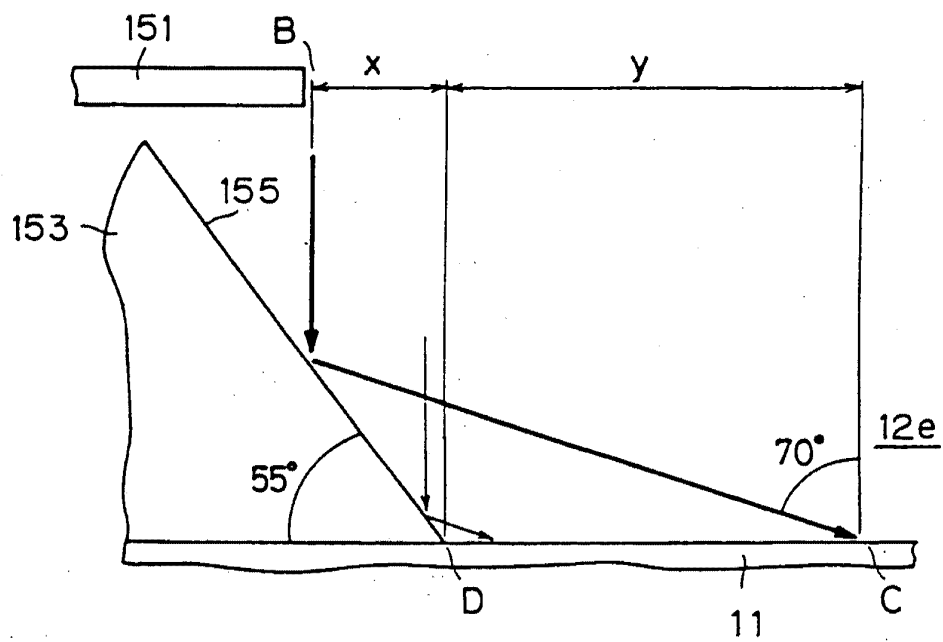




FIG. 24

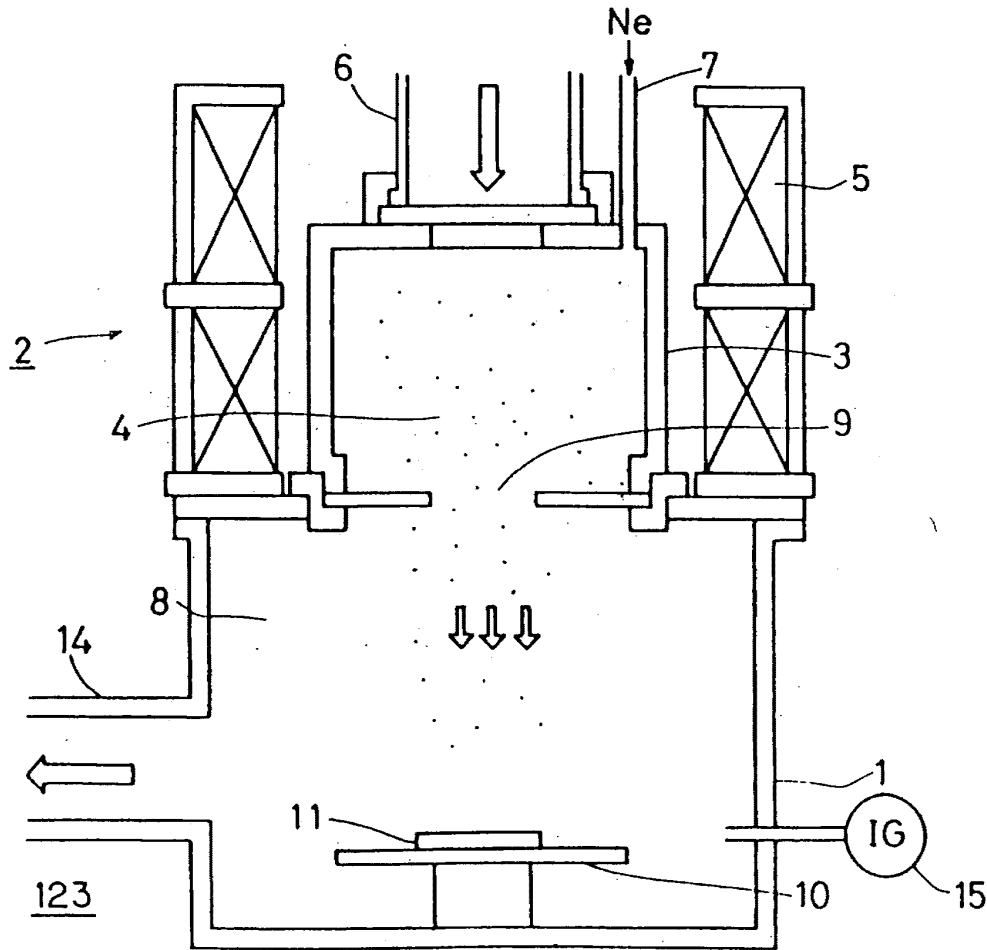


FIG. 25

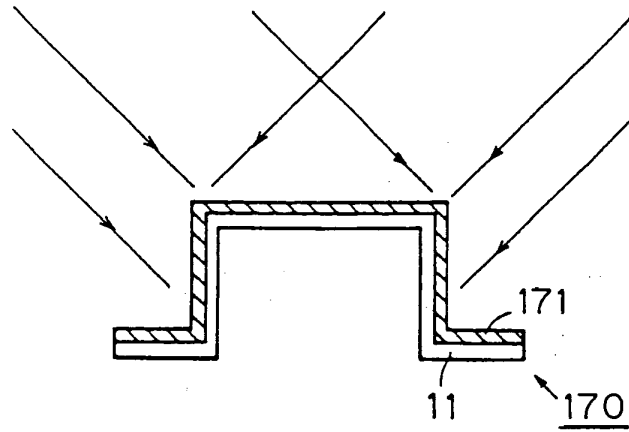


FIG. 26

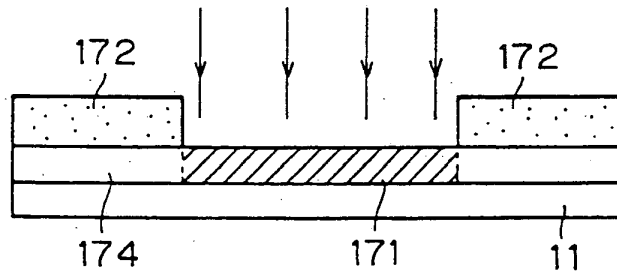


FIG. 27

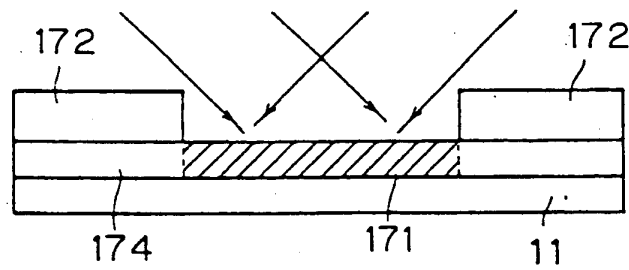


FIG. 28

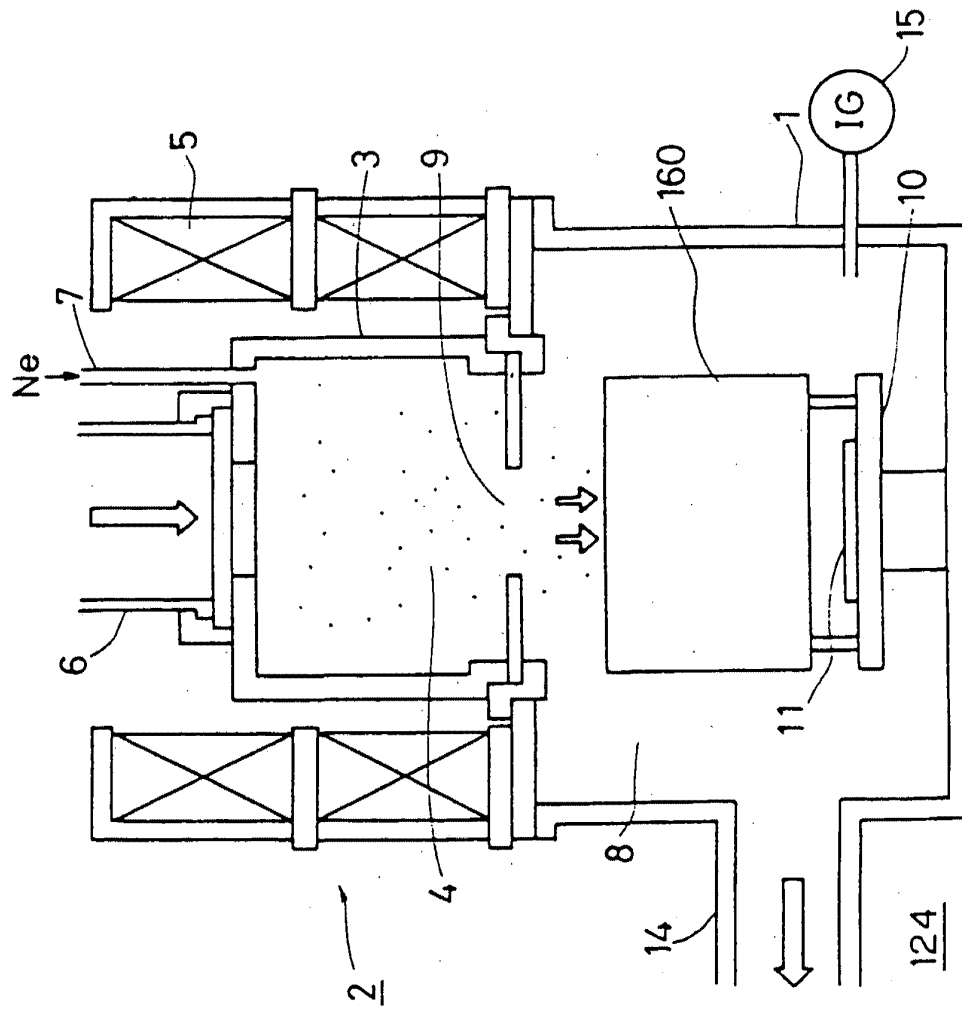


FIG. 29

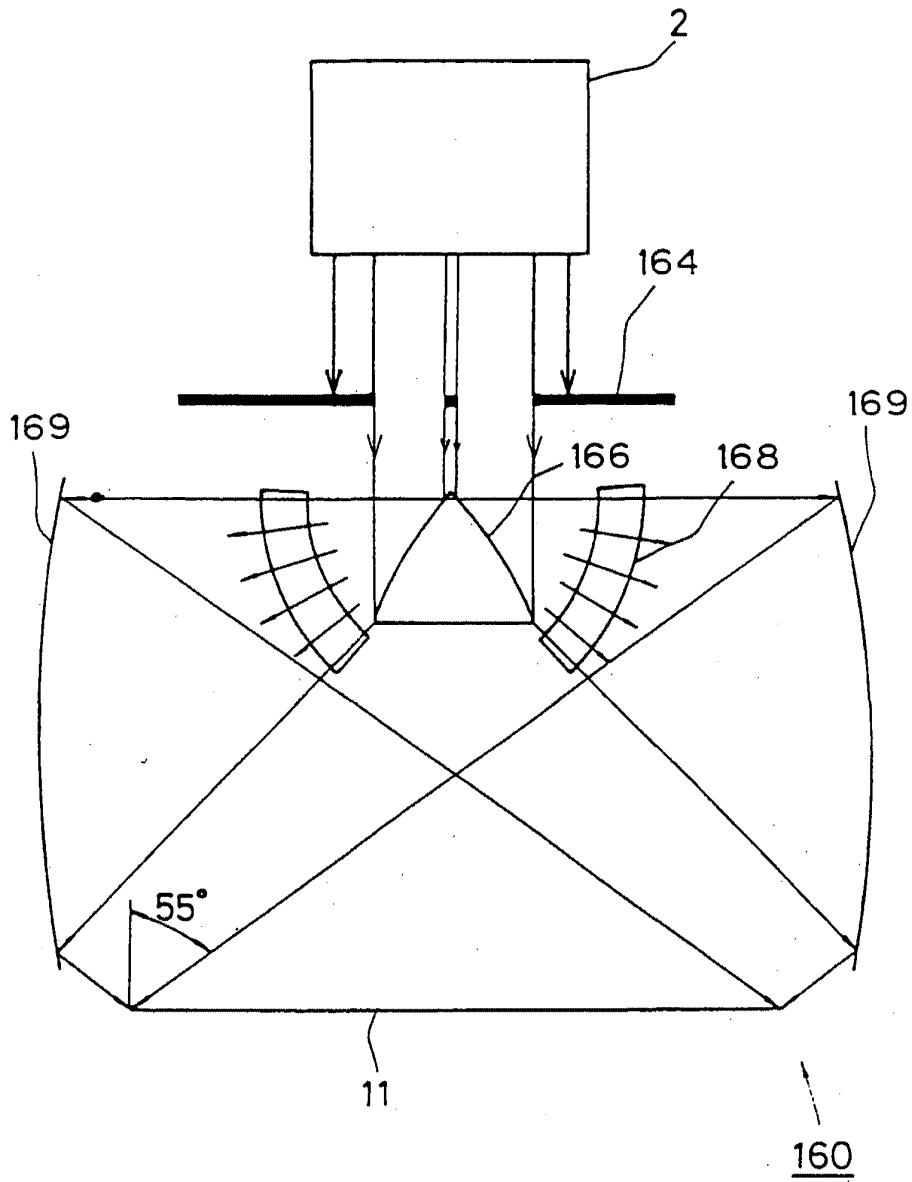




FIG. 30

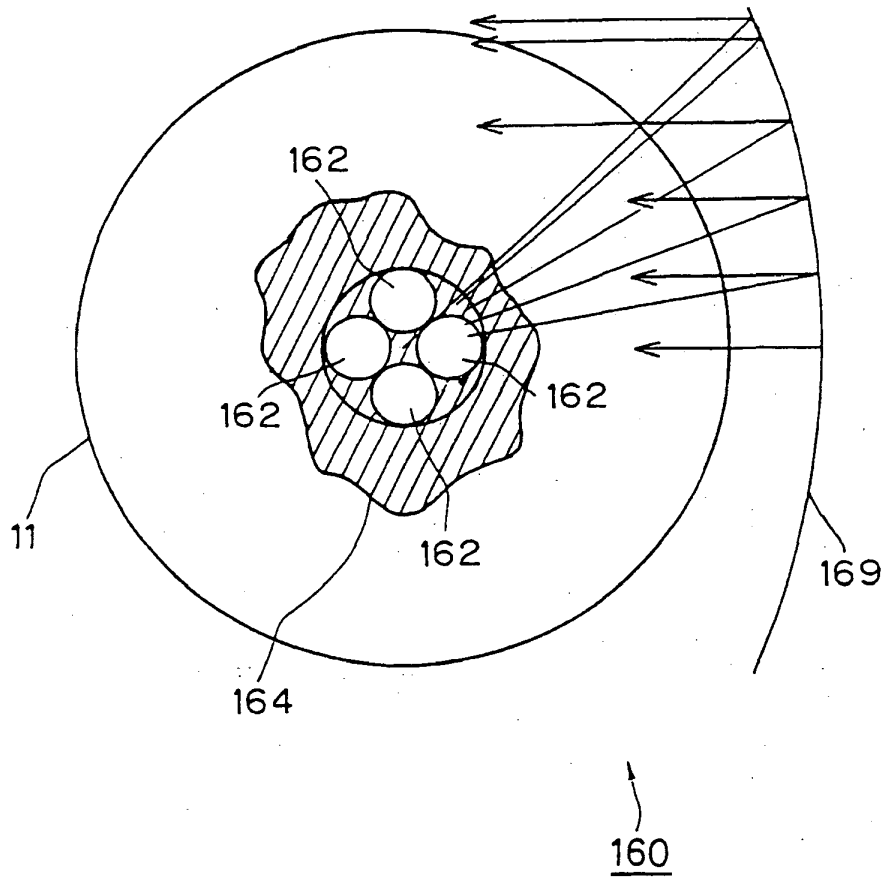
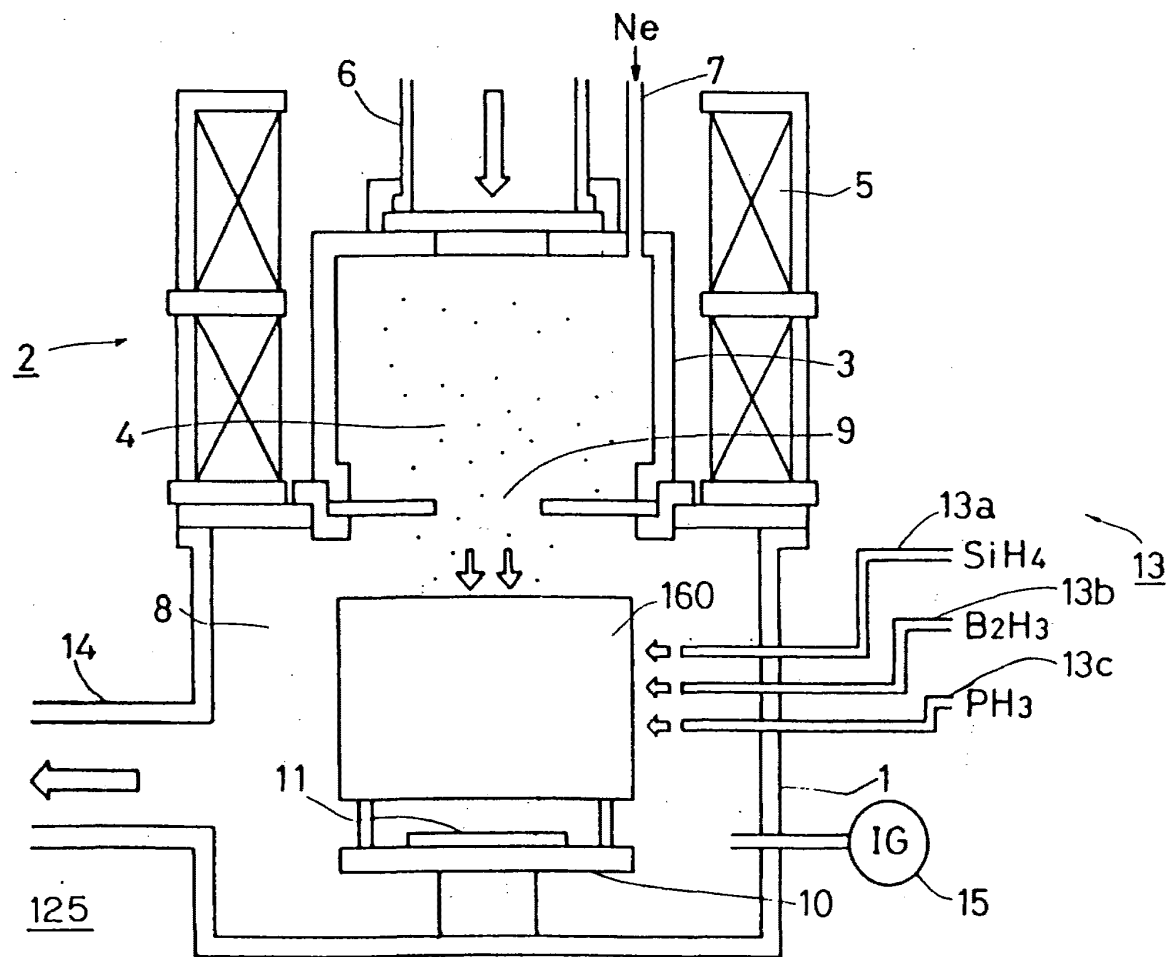


FIG. 31



EP 0 652 308 A2

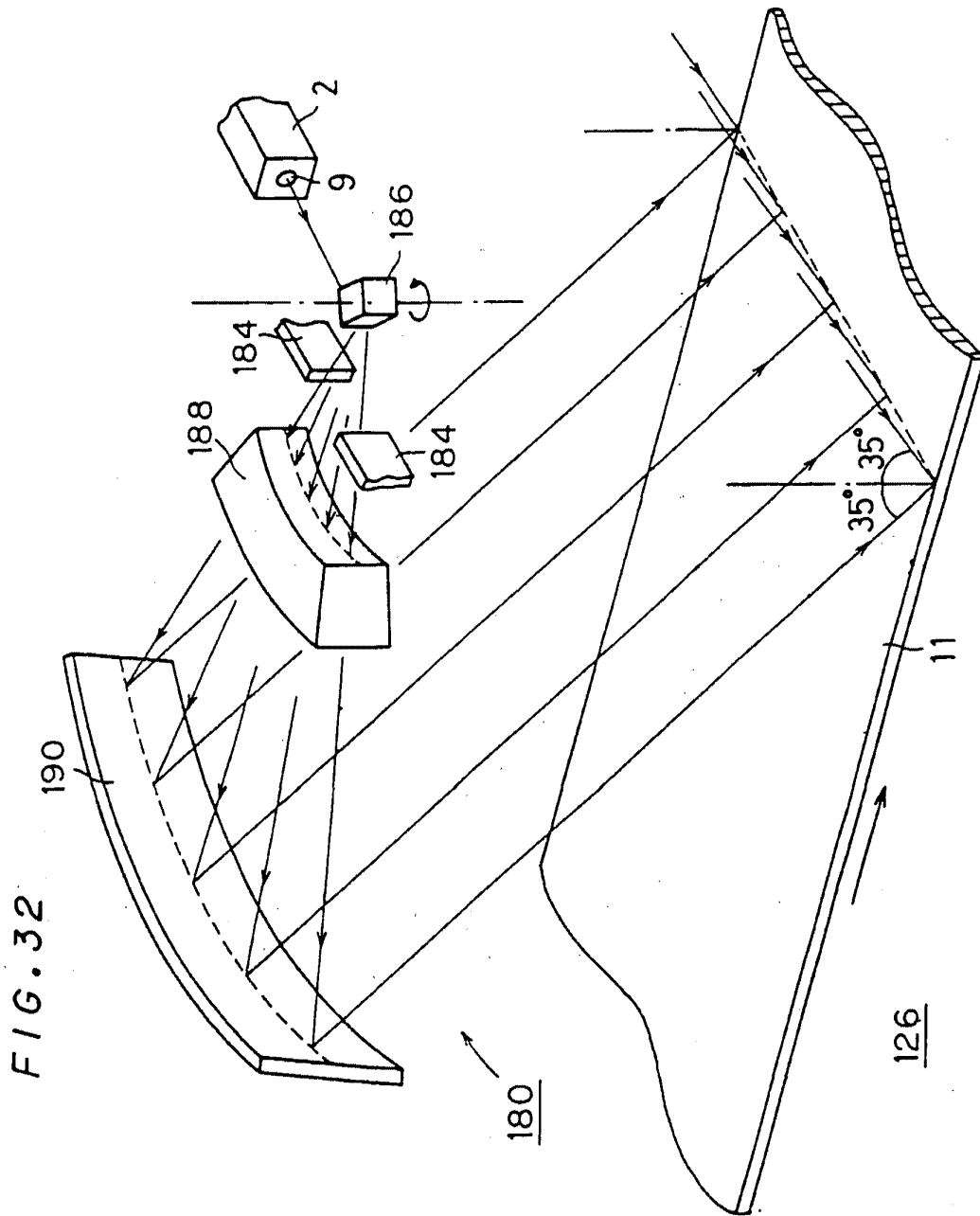


FIG. 33

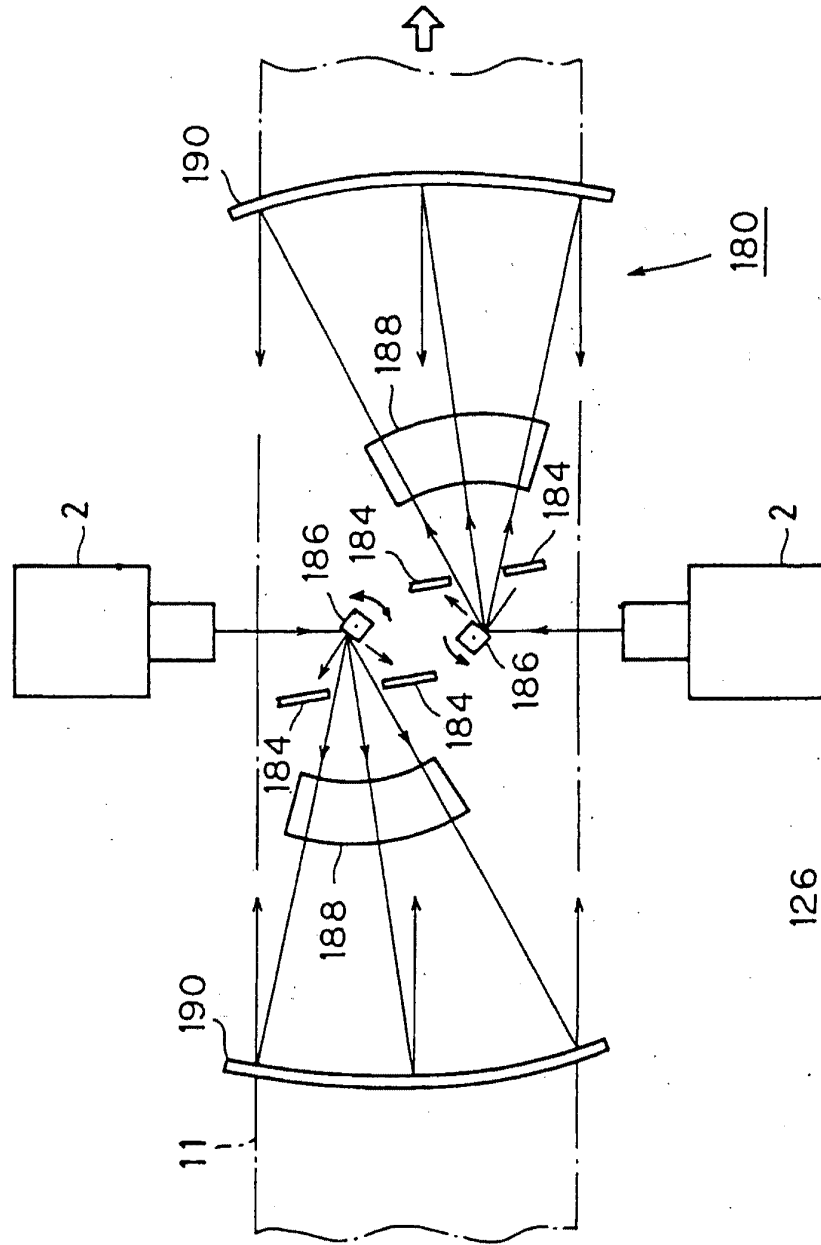


FIG. 34

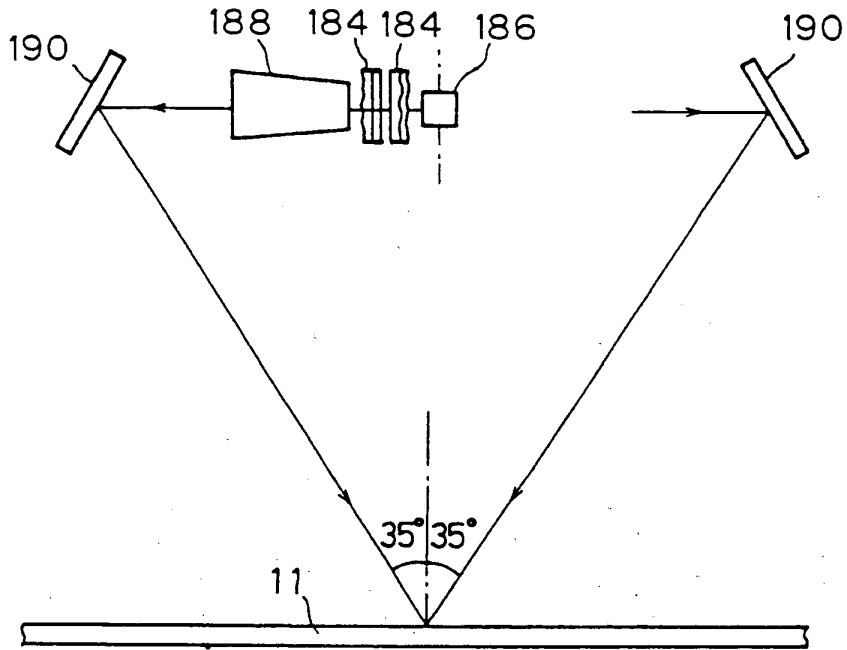
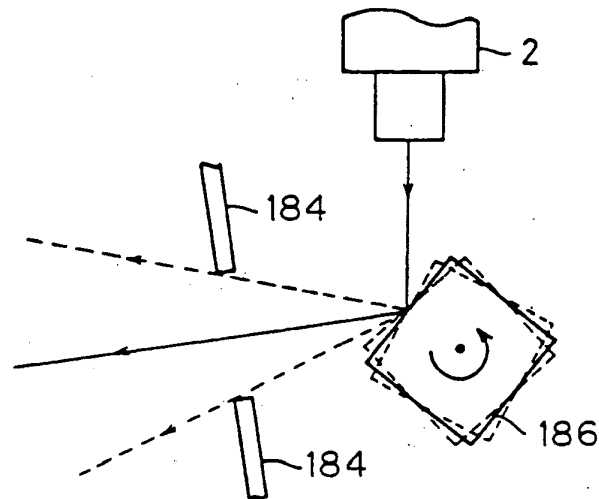


FIG. 35



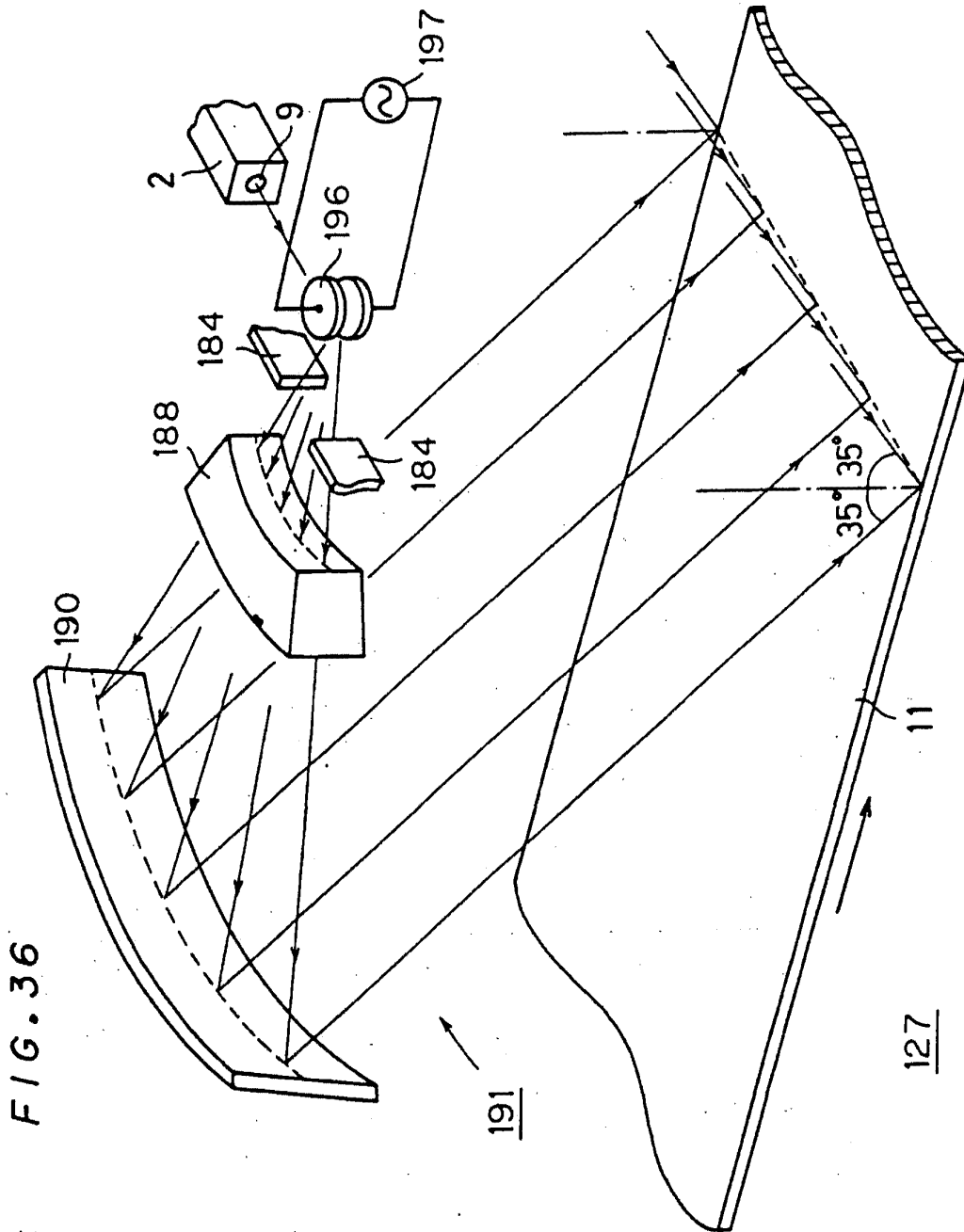


FIG. 37

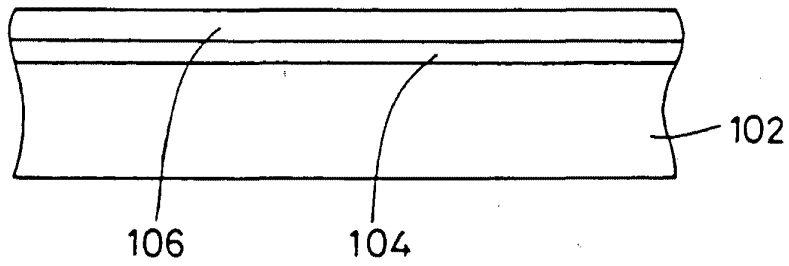


FIG. 38

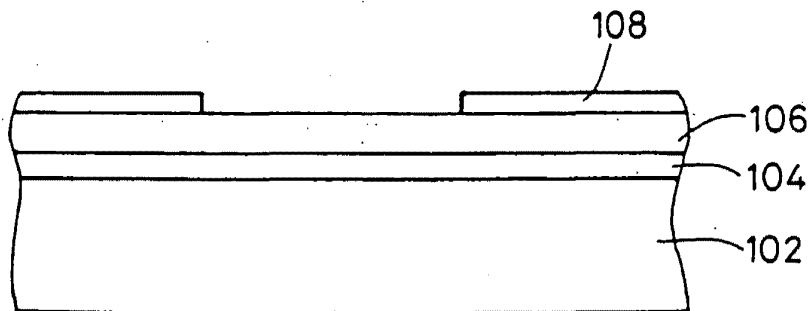


FIG. 39

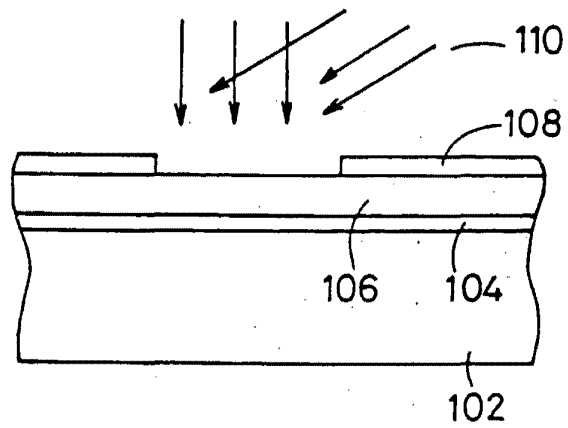


FIG. 40

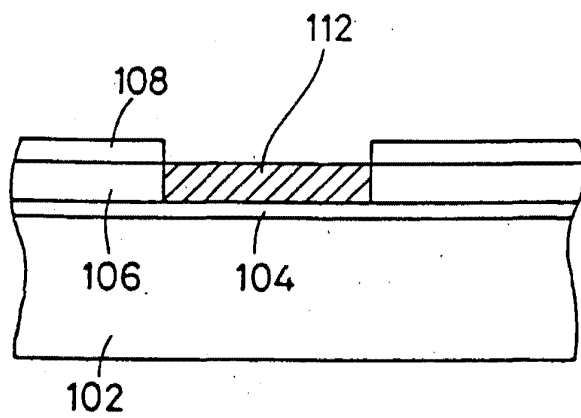




FIG. 41

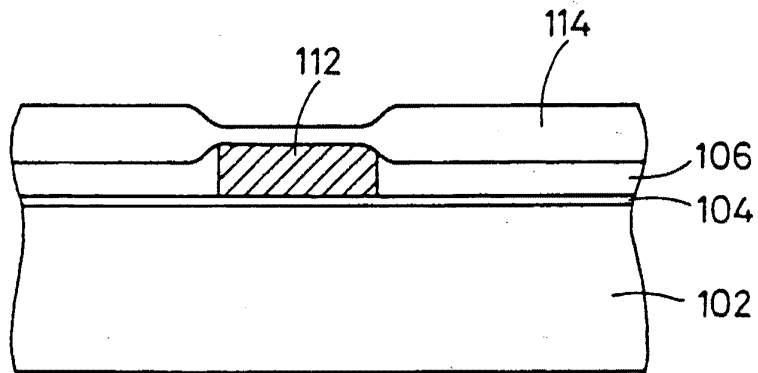


FIG. 42

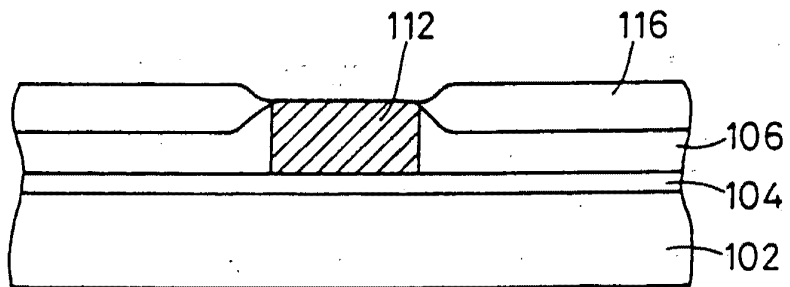


FIG. 43

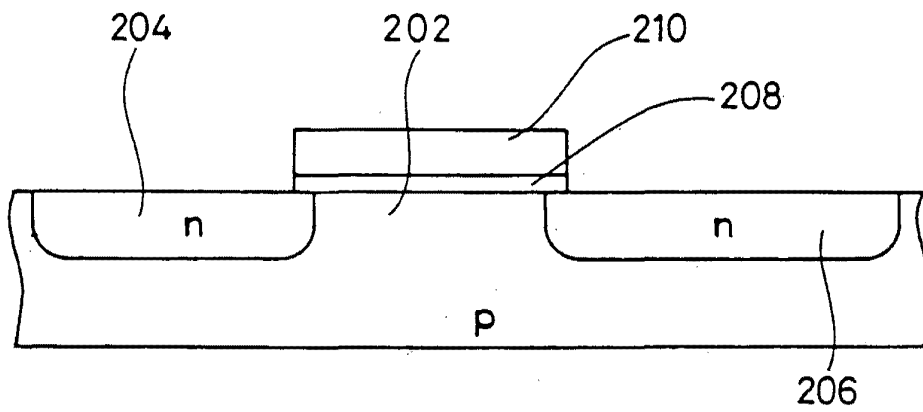


FIG. 44

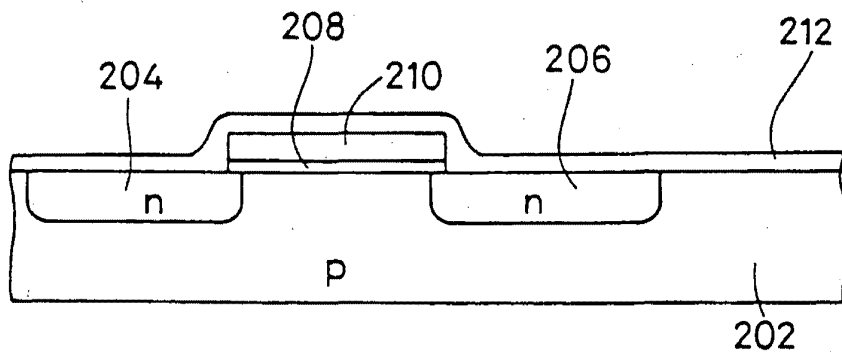


FIG. 45

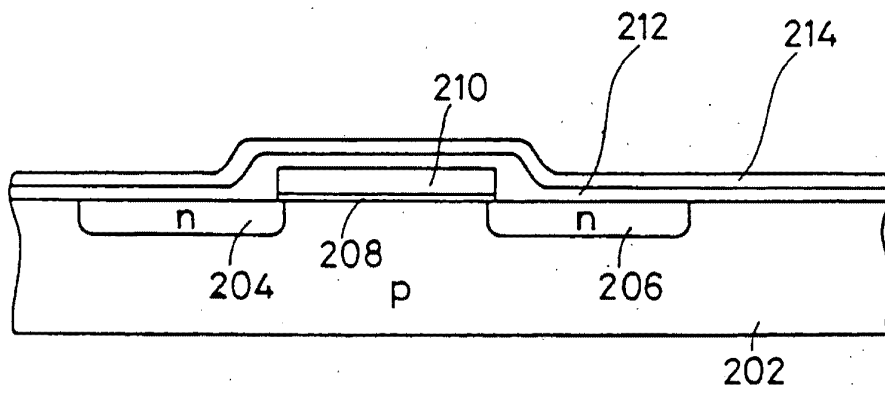
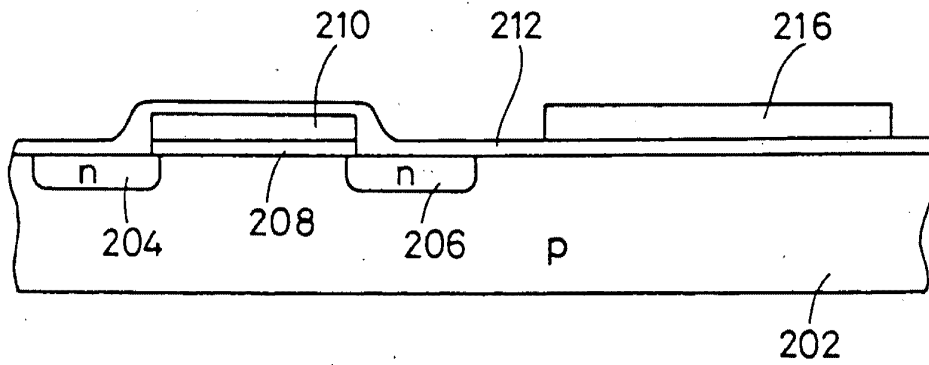


FIG. 46



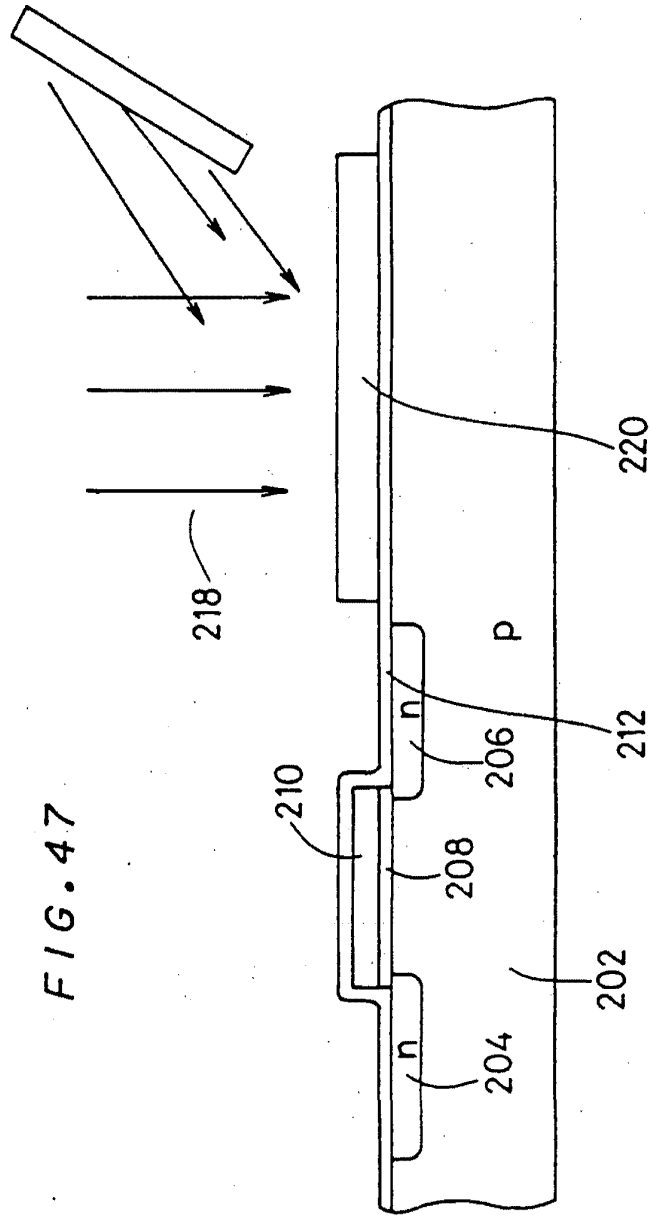


FIG. 47

FIG. 48

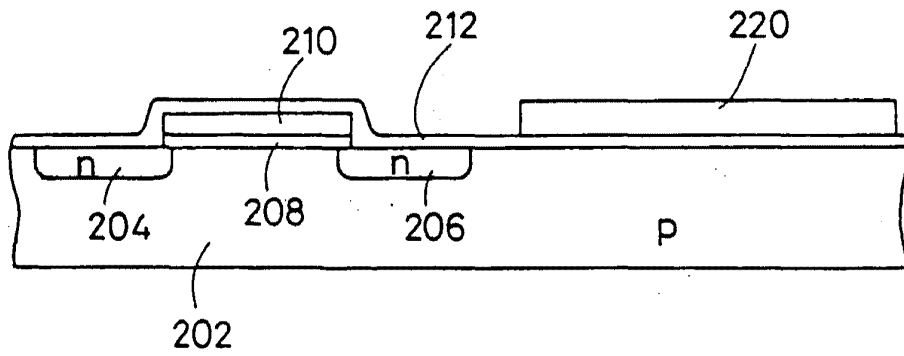


FIG. 49

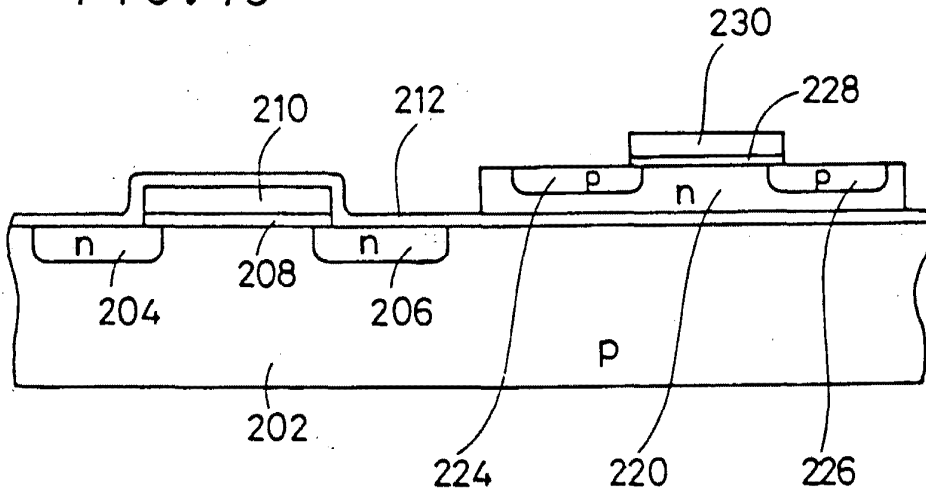


FIG. 50

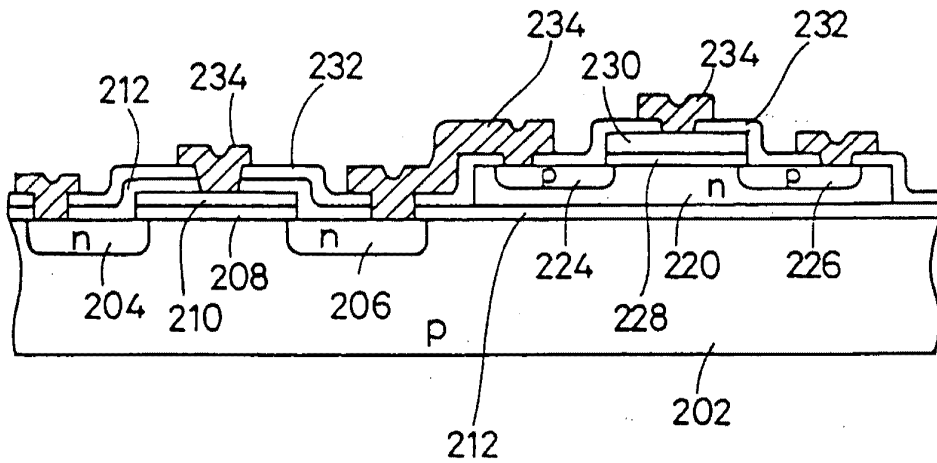


FIG. 51

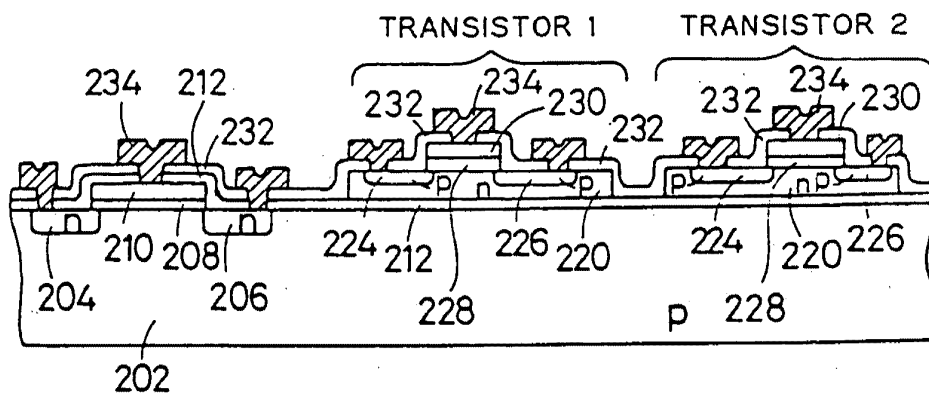


FIG. 52

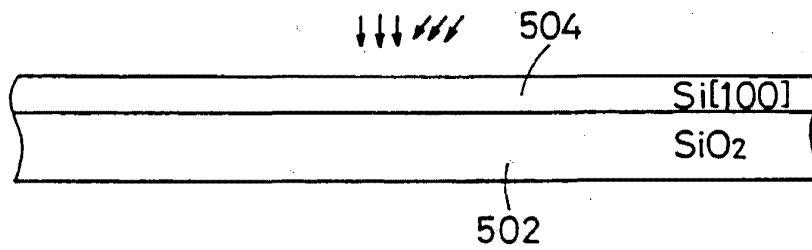


FIG. 53

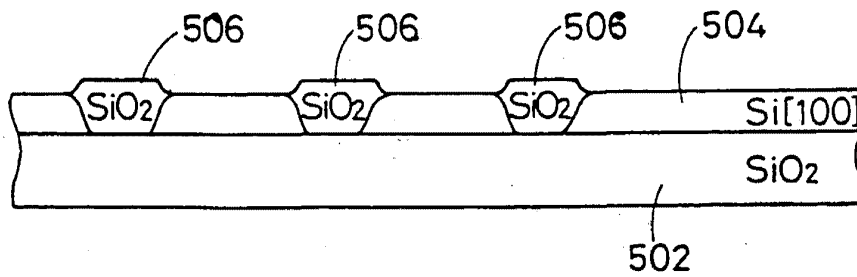


FIG. 54

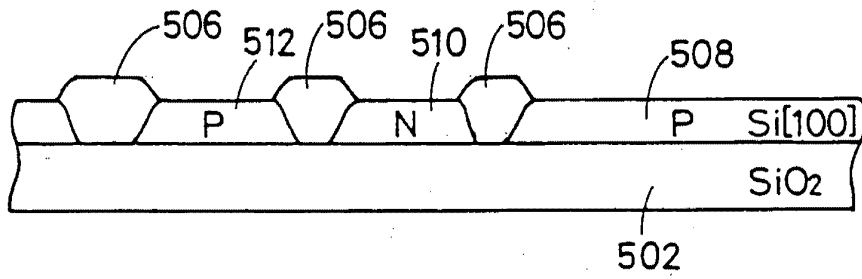


FIG. 55

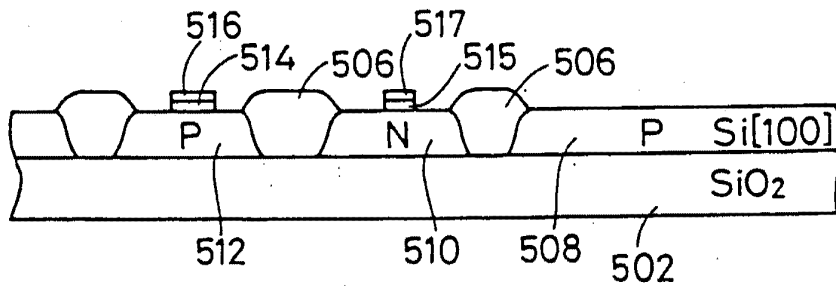




FIG. 56

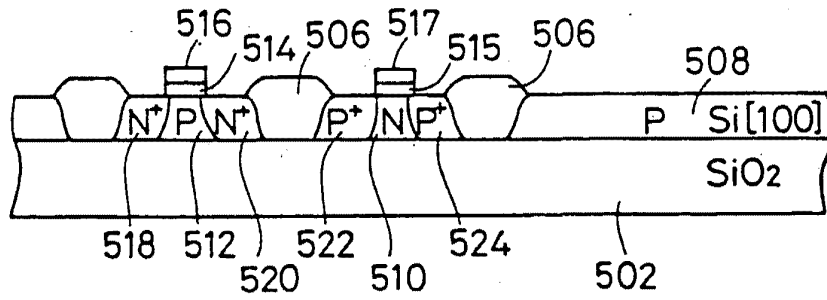


FIG. 57

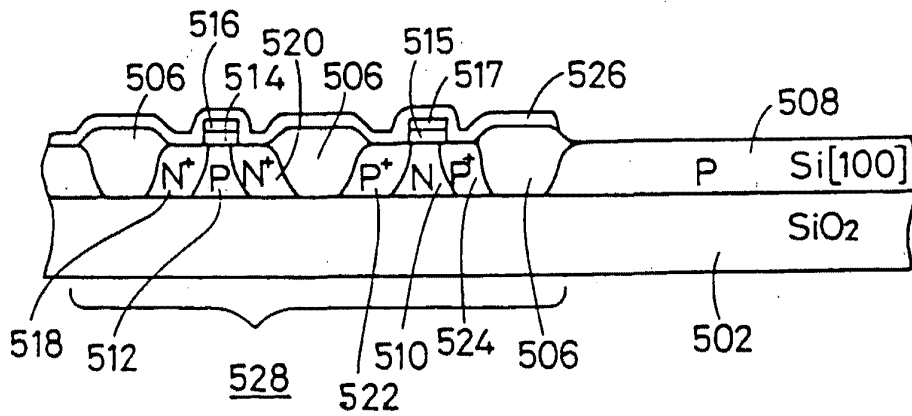


FIG. 58

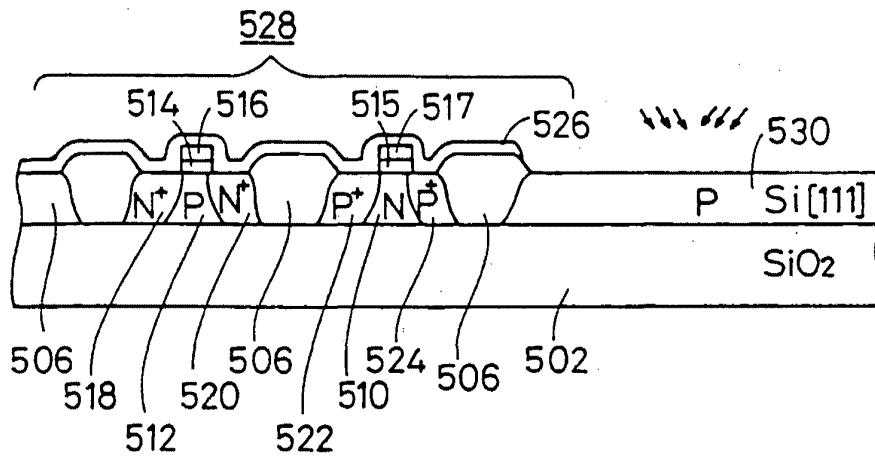


FIG. 59

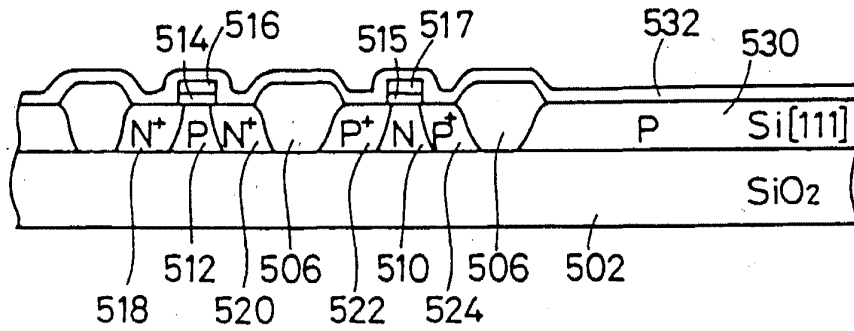


FIG. 60

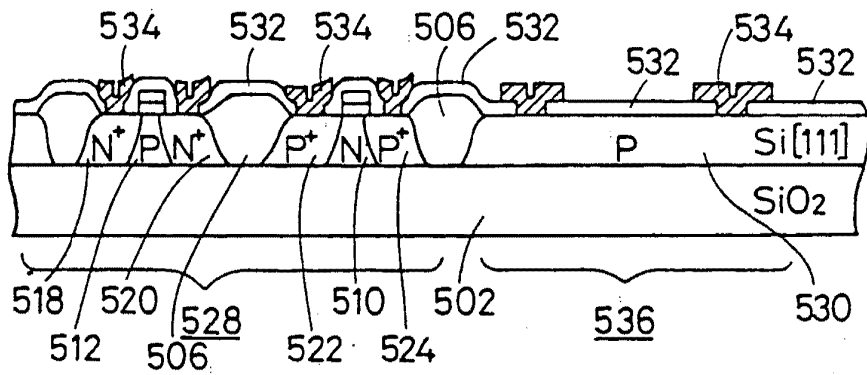


FIG. 61

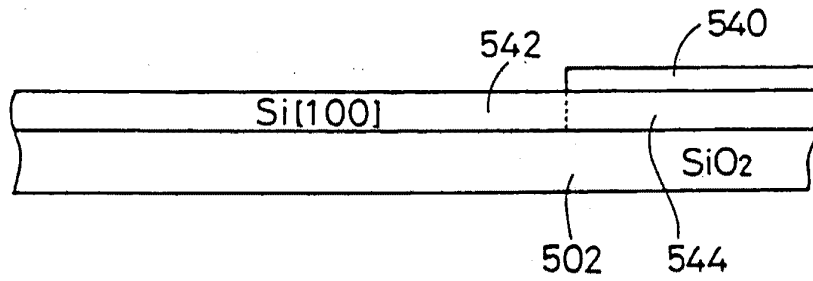






FIG. 65

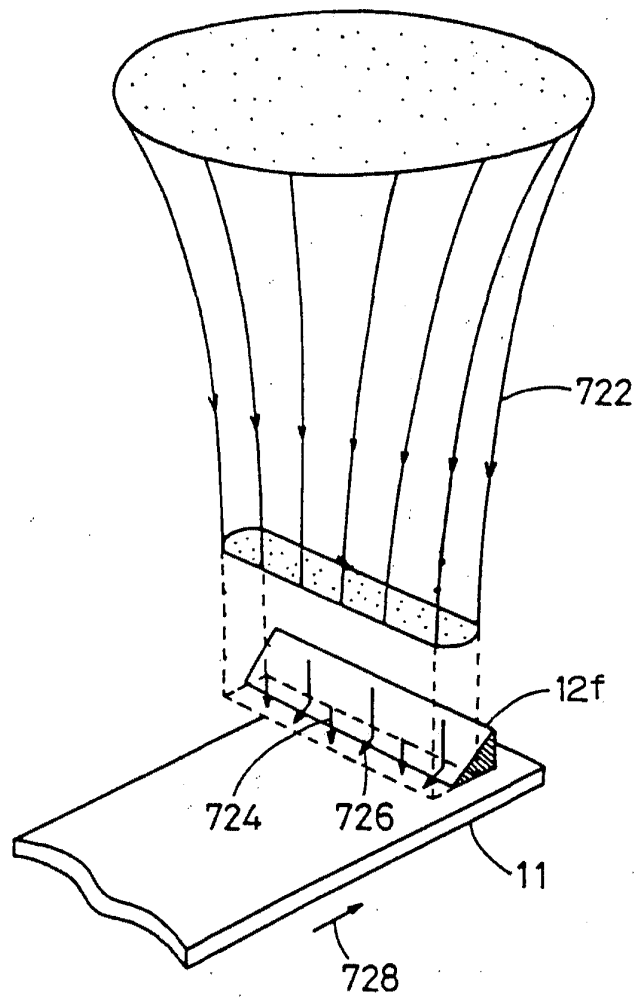


FIG. 66

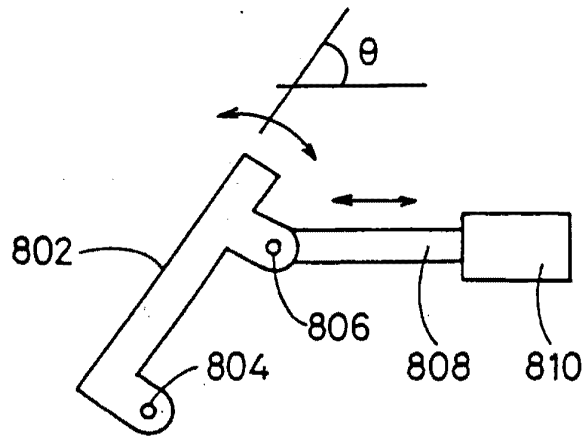


FIG. 67

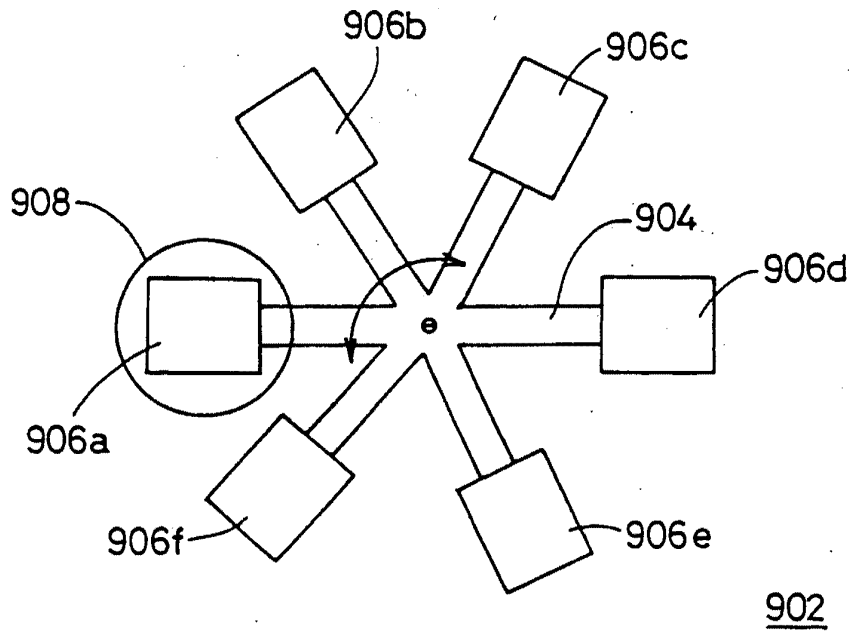


FIG. 68

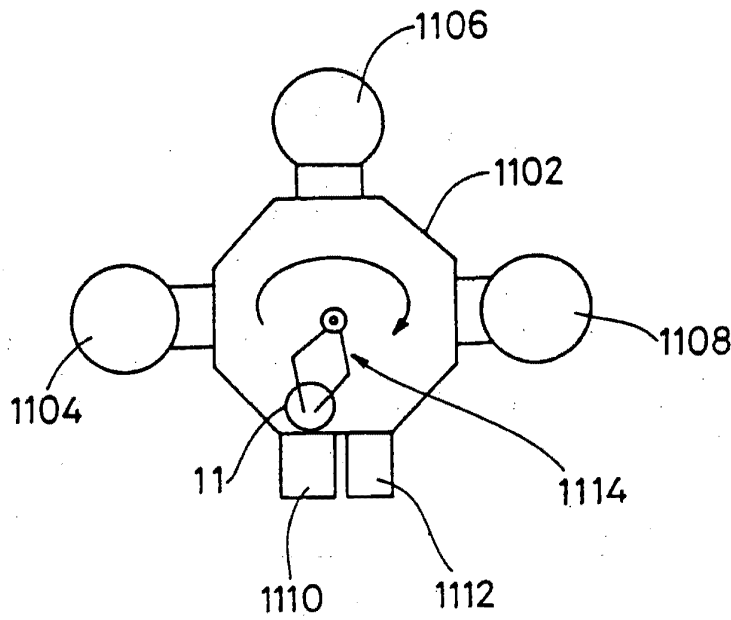




FIG. 69

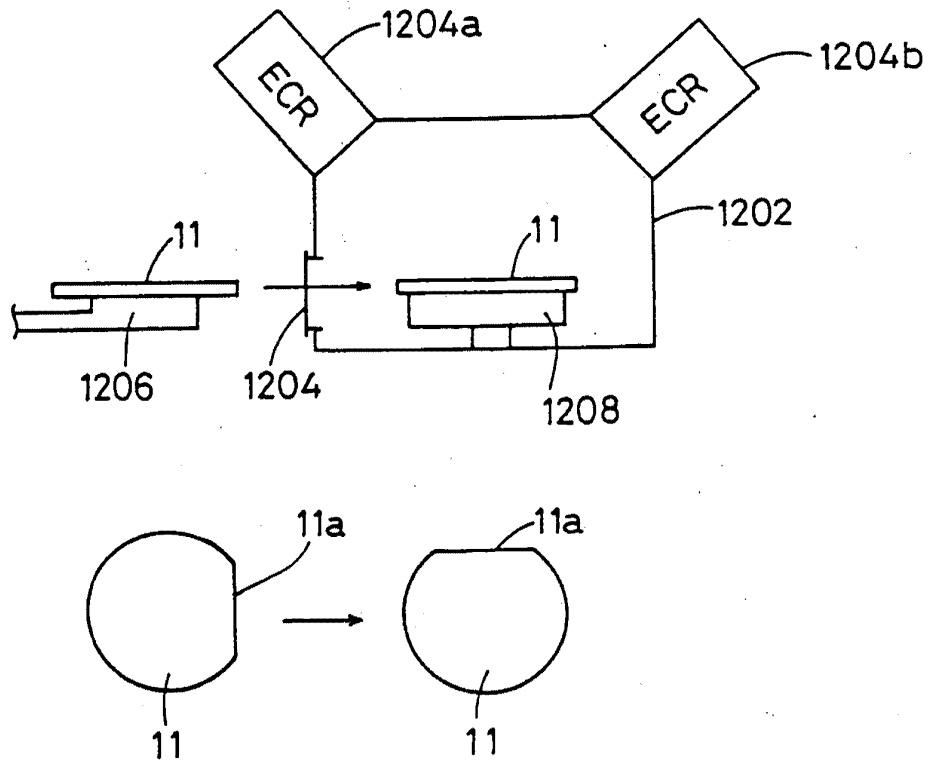


FIG. 70

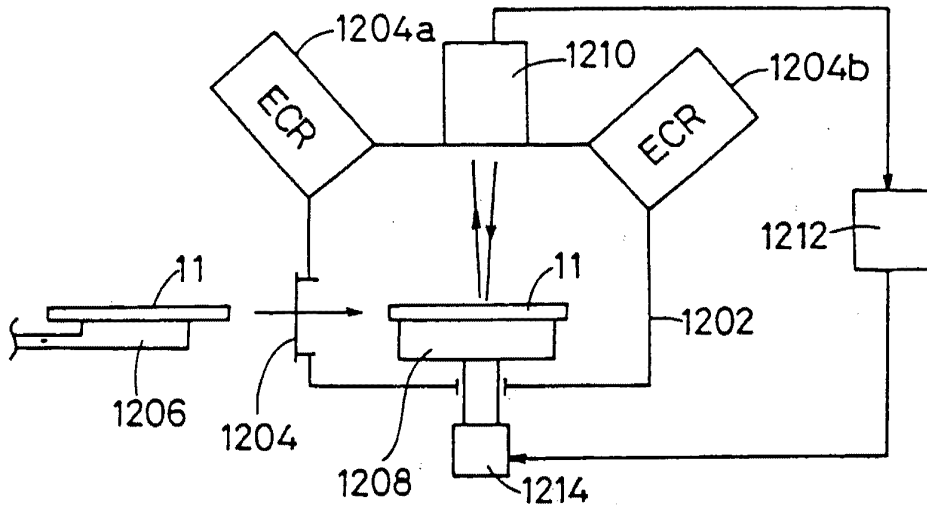


FIG. 71

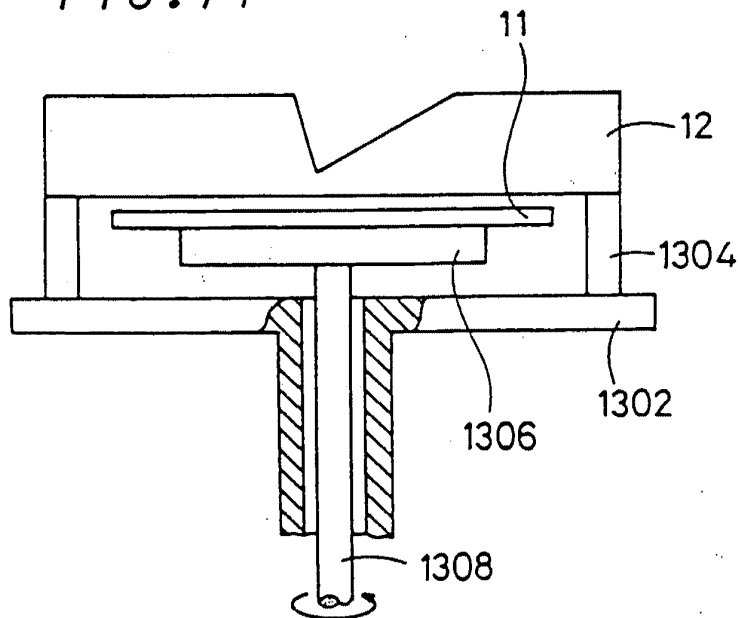


FIG. 72

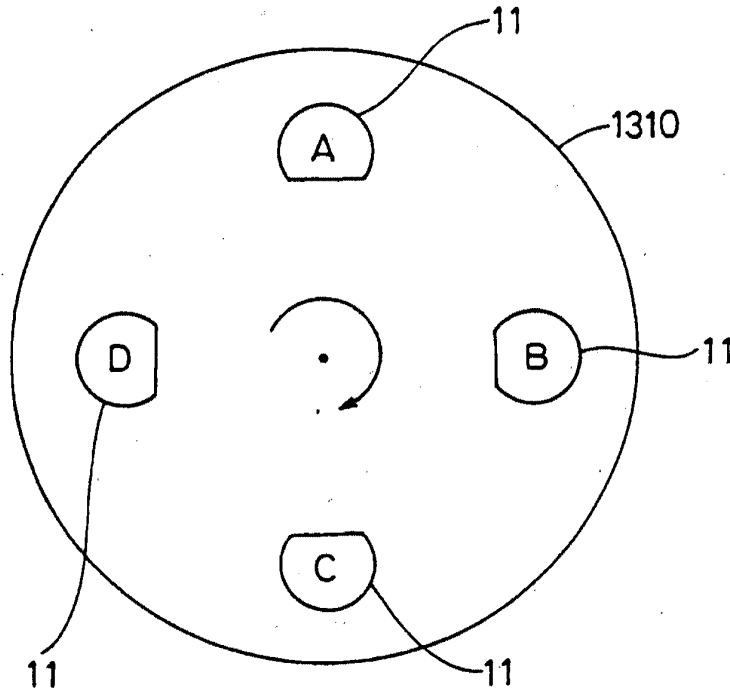


FIG. 73

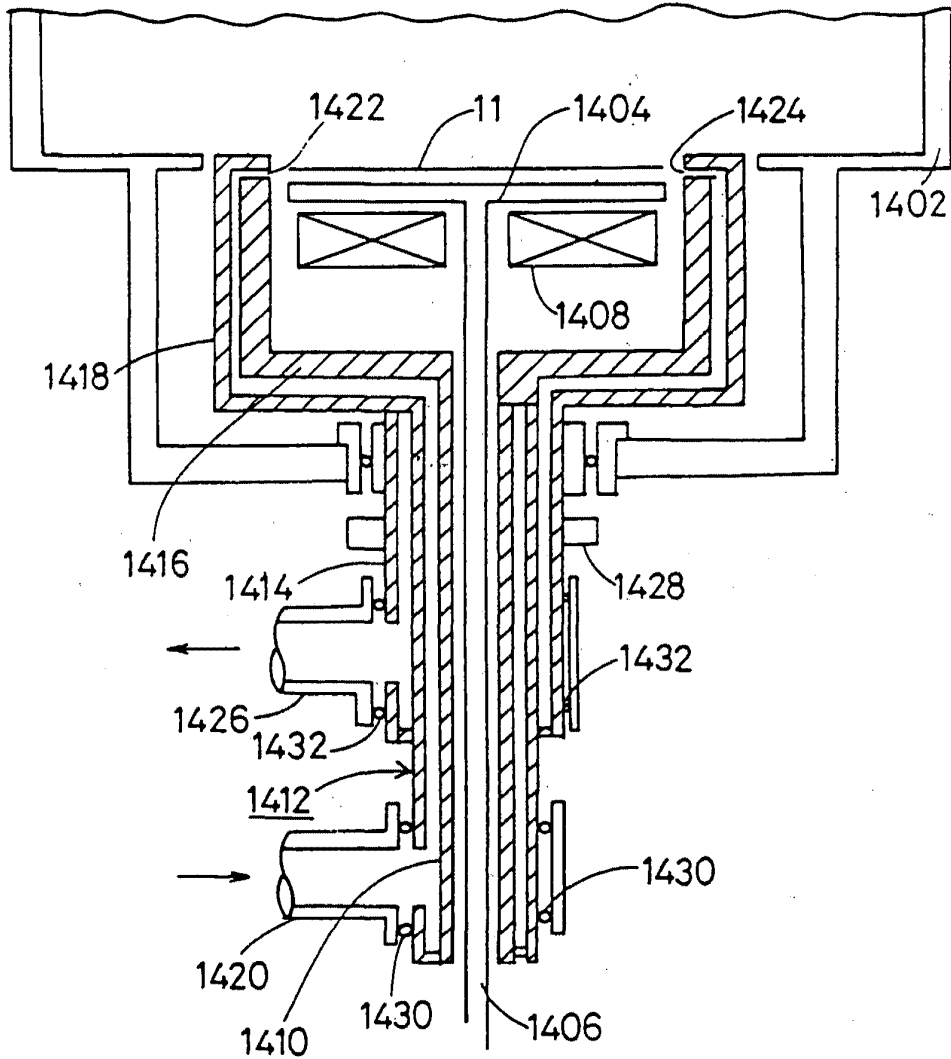


FIG. 74

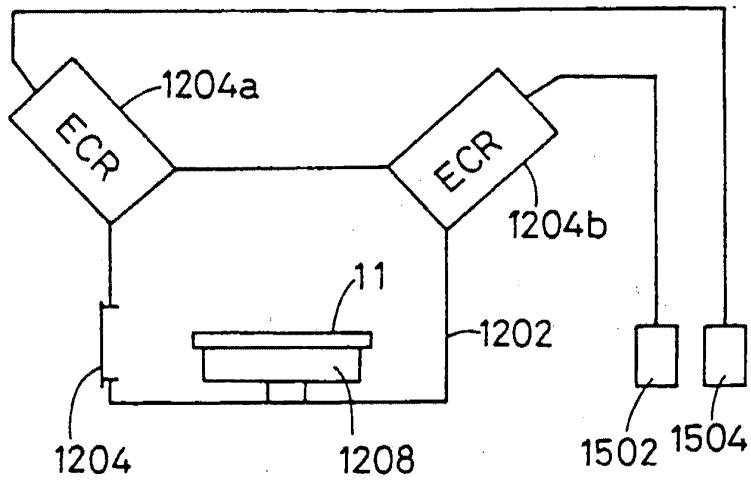


FIG. 75

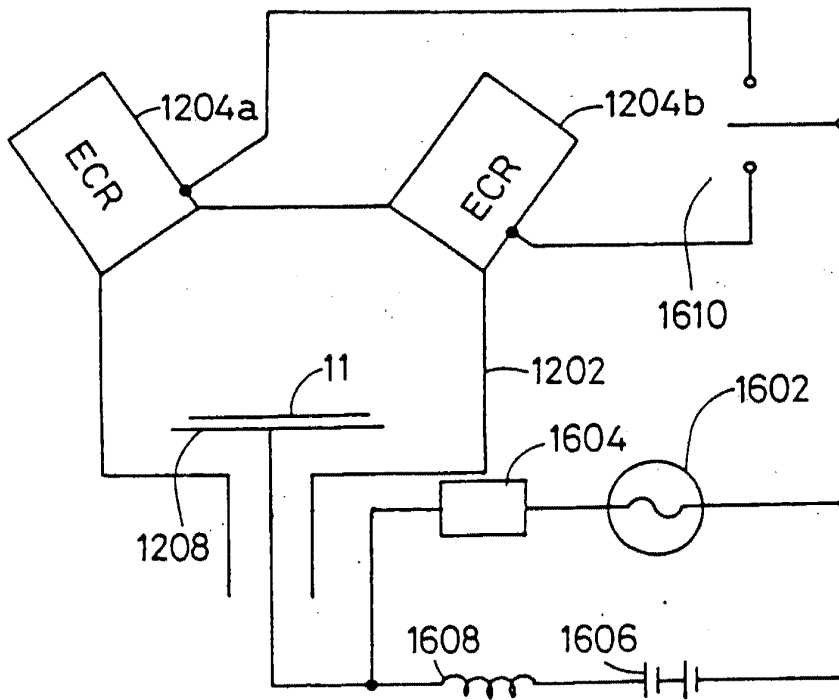
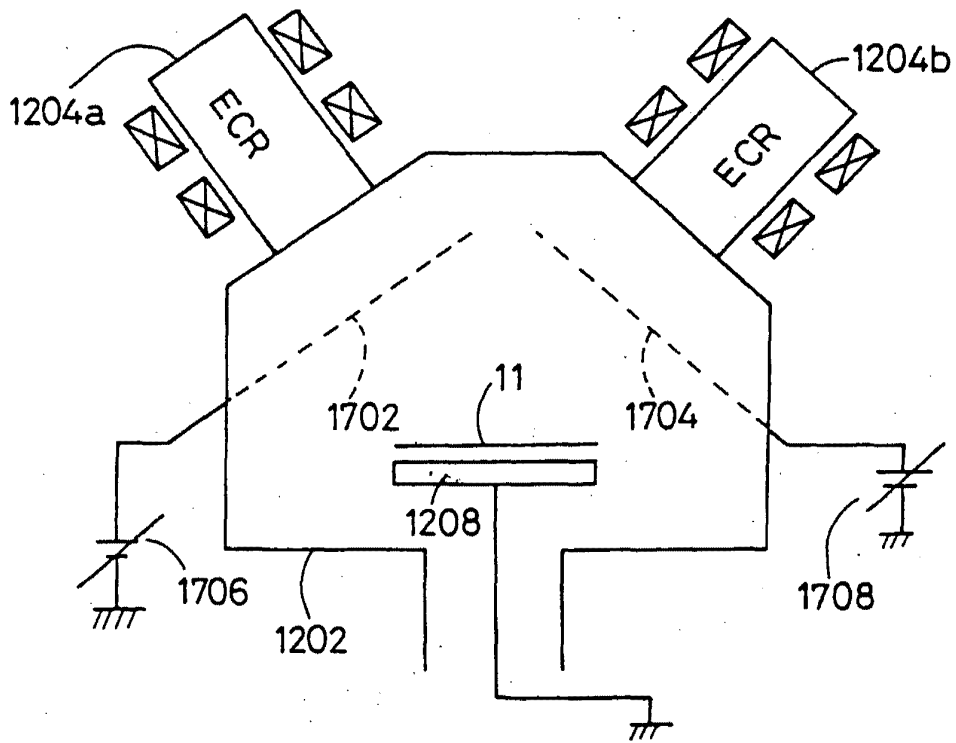


FIG. 76





Europäisches Patentamt  
European Patent Office  
Office européen des brevets



(11) EP 0 652 308 A3

(12) EUROPEAN PATENT APPLICATION

(88) Date of publication A3:  
17.12.1997 Bulletin 1997/51

(51) Int. Cl.<sup>6</sup>: C30B 23/02

(43) Date of publication A2:  
10.05.1995 Bulletin 1995/19

(21) Application number: 94116188.7

(22) Date of filing: 13.10.1994

(84) Designated Contracting States:  
DE FR GB NL

(30) Priority: 14.10.1993 JP 281748/93  
20.10.1993 JP 285674/93  
10.12.1993 JP 341281/93  
29.03.1994 JP 58887/94

(71) Applicants:  
• NEURALSYSTEMS CORPORATION  
Tokyo-to (JP)  
• MEGA CHIPS CORPORATION  
Suita-shi, Osaka-fu (JP)

(72) Inventors:  
• Asakawa, Toshifumi  
Yamato-shi, Kanagawa-ken (JP)

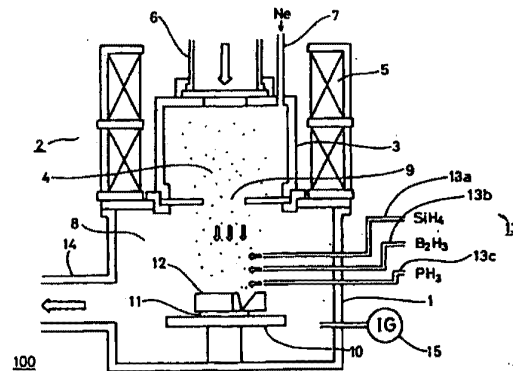
• Shindo, Masahiro,  
c/o Mega Chips Corporation  
Suita-shi, Osaka-fu (JP)  
• Yoshimizu, Toshikazu,  
c/o Mega Chips Corporation  
Suita-shi, Osaka-fu (JP)  
• Ueyama, Sumiyoshi,  
c/o Mega Chips Corporation  
Suita-shi, Osaka-fu (JP)

(74) Representative:  
KUHNEN, WACKER & PARTNER  
Alois-Steinecker-Strasse 22  
85354 Freising (DE)

(54) Method of and apparatus for forming single-crystalline thin film

(57) In order to form a single-crystalline thin film on a polycrystalline substrate using plasma CVD, a downwardly directed mainly neutral Ne atom current is formed by an ECR ion generator (2). A reaction gas such as silane gas which is supplied from a reaction gas inlet pipe (13) is sprayed onto an SiO<sub>2</sub> substrate (11) by an action of the Ne atom current, so that an amorphous Si thin film is grown on the substrate (11) by a plasma CVD reaction. At the same time, a part of the Ne atom current having high directivity is directly incident upon the substrate (11), while another part thereof is incident upon the substrate (11) after its course is bent by a reflector (12). The reflector (12) is so set that all directions of the parts of the Ne atom current which are incident upon the substrate (11) are perpendicular to densest planes of single-crystalline Si. Therefore, the as-grown amorphous Si is sequentially converted to a single-crystalline Si thin film having crystal axes which are so regulated that the densest planes are oriented perpendicularly to the respective directions of incidence, by an action of the law of Bravais. Thus, a single-crystalline thin film is formed on a polycrystalline substrate.

FIG. 13



EP 0 652 308 A3



European Patent Office

EUROPEAN SEARCH REPORT

Application Number

EP 94 11 6188

DOCUMENTS CONSIDERED TO BE RELEVANT			
Category	Citation of document with indication, where appropriate, of relevant passages	Relevant to claim	CLASSIFICATION OF THE APPLICATION (Int.Cl.6)
A	PATENT ABSTRACTS OF JAPAN vol. 10, no. 107 (C-341), 22 April 1986 & JP 60 235788 A (HITACHI SEISAKUSHO KK), 22 November 1985, * abstract *	1	C30B23/02
A	--- PATENT ABSTRACTS OF JAPAN vol. 014, no. 543 (C-0783), 30 November 1990 & JP 02 229792 A (NIYUURARU SYST:KK), 12 September 1990, * abstract *	1	
L	--- PATENT ABSTRACTS OF JAPAN vol. 095, no. 003, 28 April 1995 & JP 06 340500 A (NIYUURARU SYST:KK), 13 December 1994, *DOCUMENT WHICH MAY THROW DOUBT ON THE PRIORITY CLAIMED* * abstract *		
			TECHNICAL FIELDS SEARCHED (Int.Cl.6)
			C30B
The present search report has been drawn up for all claims			
Place of search		Date of completion of the search	Examiner
THE HAGUE		17 October 1997	Gregg, N
CATEGORY OF CITED DOCUMENTS			
X : particularly relevant if taken alone Y : particularly relevant if combined with another document of the same category A : technological background O : non-written disclosure P : intermediate document		T : theory or principle underlying the invention E : earlier patent document, but published on, or after the filing date D : document cited in the application L : document cited for other reasons & : member of the same patent family, corresponding document	

EPO FORM 1903 03.92 (04/00)





12 **EUROPEAN PATENT APPLICATION**

21 Application number : 92303476.3

22 Date of filing : 16.04.92

51 Int. Cl.<sup>5</sup> : **H01S 3/23, H01S 3/17,**  
**H01S 3/091, G02B 6/12,**  
**C03C 15/00**

30 Priority : 25.04.91 US 691262

43 Date of publication of application :  
28.10.92 Bulletin 92/44

84 Designated Contracting States :  
**DE FR GB**

71 Applicant : **AMERICAN TELEPHONE AND  
TELEGRAPH COMPANY**  
550 Madison Avenue  
New York, NY 10022 (US)

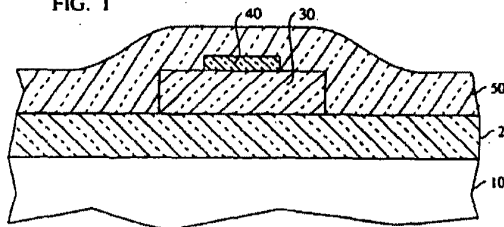
72 Inventor : **Bruce, Allan James**  
2351 Seneca Road  
Westfield, New Jersey 07090 (US)  
Inventor : **Shmulovich, Joseph**  
82 Sagamore Drive  
Murray Hill, New Jersey 07974 (US)  
Inventor : **Wong, Amy**  
169-51 25th Avenue  
Whitestone, New York 11357 (US)  
Inventor : **Wong, Yiu-Huen**  
160 Woodland Avenue  
Summit, New Jersey 07901 (US)

74 Representative : **Watts, Christopher Malcolm**  
Kelway, Dr. et al  
AT&T (UK) LTD. AT&T Intellectual Property  
Division 5 Mornington Road  
Woodford Green Essex IG8 OTU (GB)

54 **Planar optical device.**

57 An active optical device comprises a glass, waveguiding structure (20,30,40,50) disposed on a substantially planar principal surface of a substrate (10). The structure includes a silica-based, erbium-doped active core (40). The active core has an erbium-to-silicon atomic ratio of at least about 0.01, an absolute erbium concentration of at least about  $1.4 \times 10^{20}$  atoms per cubic centimeter, and a radiative lifetime of the erbium lasing level of at least about 7 milliseconds. Also disclosed is a method for forming an active optical device, including the step of depositing an erbium-doped active core by sputtering.

FIG. 1



EP 0 510 883 A2

### Field of the Invention

This invention relates to active optical devices, such as amplifiers, that operate by stimulated emission in laser glass, and more particularly to devices made in the form of planar optical waveguides.

### Art Background

Optical amplifiers are important in networks for distributing optical signals. Optical fiber amplifiers, made from glass that is doped with rare earth elements such as erbium, are a well-known example. For example, U. S. Patent No. 4,826,288, issued to R. J. Mansfield, et al. on May 2, 1989, describes one method for fabricating optical fibers having cores with relatively high rare earth content. However, for applications such as premises distribution of optical signals, where components need to be relatively small and device integration is desirable, it is advantageous to provide optical amplifiers in the form of planar waveguides deposited on silicon substrates. However, as currently envisioned, such devices are much shorter than optical fiber amplifiers, and the required level of doping is correspondingly much greater.

Attempts to deposit layers of glass at the high doping level appropriate for this purpose have been generally unsatisfactory. For example, a doped soot layer can be formed by chemical vapor deposition, and subsequently sintered to form a glass layer. A method for forming glass waveguides is described, for example, in U.S. Patent No. 4,425,146, issued to T. Izawa, et al., on January 10, 1984. A process forming sintered glasses containing rare earth dopants is described, for example, in U.S. Patent No. 4,826,288, issued to R. J. Mansfield, et al., on May 2, 1989. However, the sintering temperature required, which may be as much as about 1200°C, may promote phase separation and may damage underlying structures on the substrate. As a consequence, it would be advantageous to find a core glass composition that can be doped with erbium and incorporated in a waveguide amplifier without exposing the waveguide structure to potentially damaging, high temperatures.

### Summary of the Invention

In a broad sense, the invention is an active optical device in the form of a planar optical waveguiding structure. The device includes an elongate, active glass core which comprises silicon, oxygen, and erbium, the erbium being at least partially in the form of Er<sup>3+</sup> ions. The active core further comprises an alkali metal or alkaline earth metal in an effective quantity to prevent clustering of erbium atoms. The device further includes a glass cladding, means for coupling signal radiation into and out of the active core, and means for coupling pump radiation into the active core

to pump the Er<sup>3+</sup> ions. The cladding and core are formed such that they overlie a substantially planar principal surface of a substrate. In the active core, the erbium-to-silicon atomic ratio is at least about 0.01, the absolute erbium concentration is at least about  $1.4 \times 10^{20}$  atoms per cubic centimeter, and the erbium lasing level has a radiative lifetime of at least about 7 ms.

In another aspect, the invention is a method for forming an optical device on a silicon substrate having a substantially planar principal surface. The method includes, first, the step of forming a first layer of vitreous silicon dioxide on the principal surface. After that, a second layer of silica-based glass is deposited over the first layer by sputtering a target of silica-based glass containing sodium and erbium such that the second layer has a higher refractive index than the first layer. Significantly, the target composition is selected such that the core has an erbium-to-silicon atomic ratio of at least about 0.01 and a sodium-to-silicon atomic ratio in the approximate range 0.2 - 0.6, the absolute erbium concentration is at least about  $1.4 \times 10^{20}$  atoms per cubic centimeter, and the target composition is further selected such that a lasing level is associated with the erbium in the core, the lasing level having a radiative lifetime of at least about 7 ms. After the sputtering step, the second layer is annealed such that it is stabilized. A portion of the second layer is subsequently removed by etching, such that an elongate core is formed. After that, a third layer of phosphosilicate glass is deposited over the core such that the third layer has a smaller refractive index than the core.

### Brief Description of the Drawings

FIG. 1 is a schematic, sectional end view of the inventive waveguiding structure, according to one embodiment.

FIG. 2 is a schematic, top view of the waveguiding structure of FIG. 1.

FIG. 3 is a schematic, sectional side view of the inventive waveguiding structure, according to an alternative embodiment.

FIG. 4 is a flowchart of the steps in an exemplary process for manufacturing the inventive waveguiding structure.

### Detailed Description Of A Preferred Embodiment

The inventive optical amplifier is to be used to amplify optical signals by stimulated emission from Er<sup>3+</sup> ions. As is well known in the art, the appropriate signal wavelength is about 1.55 μm. Various wavelengths of pump radiation are readily used to excite the Er<sup>3+</sup> ions, as is described in greater detail below.

With reference to FIG. 1, a currently preferred embodiment of the inventive optical amplifier includes a silicon substrate 10, a lower cladding layer 20 overlying

ing the substrate, a passive core 30 overlying the lower cladding layer, an active core 40 overlying the passive core, and an upper cladding layer 50 overlying the active and passive cores and the lower cladding layer. In alternative embodiments of the invention, the passive core is omitted.

As is apparent in the figure, the two cores are substantially surrounded by the two cladding layers. The refractive indices of the upper and lower cladding layers are not necessarily equal to each other. However, they should both be smaller than the refractive index of the active core, and also smaller than the refractive index of the passive core. As a consequence of the refractive index differences, electromagnetic radiation of the signal wavelength and at least one pump wavelength is guided in both the active core and the passive core. (In general, the waveguiding properties of the active and passive cores are not distinctly separable. Thus, for example, radiation guided in the active core is not guided exclusively therein, but by an effective core to which the underlying passive core also contributes.)

Preferably, the active and passive cores function as single-mode waveguides, at least with respect to the signal wavelength. Thus, signal radiation is preferably guided exclusively in the fundamental mode. However, it should be noted that alternative embodiments are envisioned in which both the active and the passive cores function as multimode waveguides with respect to both the signal and pump radiation.

The refractive index of the active core is preferably somewhat greater than the refractive index of the passive core, in order to capture the greatest possible amount of light in the active core. (For example, active and passive cores are readily made having respective refractive indices of 1.50 and 1.45.) As a consequence of such refractive index difference, electromagnetic waves that are guided in the active core will have narrower mode profiles than waves guided in the passive core. Accordingly, it is advantageous in such situations to make the active core narrower than the passive core. Such a relatively narrow active core 40 is depicted in FIG. 1.

Lower cladding layer 20 is formed on an appropriately prepared, substantially planar principal surface of substrate 10, which is exemplarily a silicon wafer. Layer 20 is exemplarily a HIPOX layer; i.e., a layer of vitreous silicon dioxide that is grown by thermal oxidation of silicon under high pressure steam according to methods that are well-known in the art. The thickness of layer 20 should be greater than about 10  $\mu\text{m}$ , because optical leakage may occur at substantially smaller thicknesses. A currently preferred thickness is about 15  $\mu\text{m}$ .

Passive core 30 is exemplarily made from phosphosilicate glass. The phosphorus content, and concomitantly the refractive index, of the glass is selected (with reference to the compositions of layers 20 and

50 and active core 40) to provide the desired waveguiding properties, according to methods well known in the art. A useful range of glass compositions for passive core 30 consist of silica containing up to about 8 wt.% phosphorus, and the phosphorus content more typically lies in the range 4 - 8 wt.%. Core 30 is exemplarily deposited on layer 20 by low-pressure chemical vapor deposition, according to methods that are well-known in the art. The thickness of the passive core is exemplarily about 5  $\mu\text{m}$ , and the width of the passive core is exemplarily about 7  $\mu\text{m}$ .

Active core 40 is made from a silica-based glass having a relatively high concentration of erbium, e.g., glass having an erbium-to-silicon atomic ratio of at least about 0.01, preferably at least about 0.02, and still more preferably at least about 0.03. Furthermore, the absolute erbium concentration is at least about  $1.4 \times 10^{20}$  atoms per cubic centimeter. A smaller erbium-to-silicon ratio is undesirable because it could lead to an undesirably small value of signal gain per unit length of the amplifier.

Various glass-modifying chemical elements (hereafter, "modifiers") are advantageously added to the glass of the active core in order to increase the solubility of erbium in the glass, and thus to prevent clustering of erbium atoms at high concentrations. Certain modifiers have been found to increase erbium solubility while avoiding concentration-quenching effects, which would otherwise reduce the  $\text{Er}^{3+}$  radiative lifetime below about 7 ms at relatively high concentrations (i.e., at erbium-to-silicon atomic ratios greater than about 0.02). Modifiers that are useful in this regard include alkali metals such as sodium and alkaline earth metals such as calcium.

Modifiers are also usefully incorporated in the active core glass to control the homogeneous and inhomogeneous broadening of the  $\text{Er}^{3+}$  absorption and emission peaks. Such modifiers include alkali and alkaline earth metals, which in at least some cases tend to make the peaks narrower, and elements such as lanthanum, yttrium, and zirconium, which contribute high field-strength ions and tend to broaden the peaks. Modifiers (such as aluminum and gallium) that enhance the degree of cross linkage in the glass network may also increase the degree of inhomogeneous broadening. In some cases, such modifiers are advantageously added to offset the effects of other modifiers on the absorption and emission peaks.

Modifiers are also usefully incorporated in order to stabilize the glass against devitrification, crystallization, and attack by moisture during or after film deposition. Modifiers useful for that purpose include calcium, magnesium, aluminum, and lanthanum. (Because the active core glass typically has a greater thermal expansion coefficient than the underlying silicon and silica regions, it may also be advantageous to add modifiers that reduce the thermal expansion.)

Thus, for example, an active core glass with a rel-

atively high solubility for erbium is readily made by incorporating in silica glass an effective amount of sodium. An effective range for the sodium-to-silicon atomic ratio is from about 0.2 to about 0.6. An optional quantity of calcium, up to a calcium-to-silicon atomic ratio of about 0.2, is usefully incorporated in order to enhance erbium solubility and to stabilize the glass, as discussed above. An optional quantity of aluminum, up to an aluminum-to-silicon atomic ratio of about 0.1, is usefully incorporated in order to stabilize the glass. Similarly, optional quantities of other modifiers, such as those listed above, are usefully added in quantities that are limited, inter alia, by the ultimate refractive index desired and the relevant solubility limits.

An exemplary method for depositing active core 40 is by sputtering, as described in detail below. As noted, the refractive index of active core 40 should be greater than those of both cladding layers, and also greater than the refractive index of passive core 30. Significantly, the use of sputtering offers the advantage that the concentration of  $\text{Er}^{3+}$  ions can be made substantially uniform throughout the active core. Moreover, radiation damage (which can occur when erbium doping is performed by ion implantation) is avoided.

The thickness of the active core is exemplarily about  $1.2 \mu\text{m}$ . If the active core is made substantially thinner than about  $1.0 \mu\text{m}$ , there will be no guided mode at the signal wavelength. The width of the active core should be at least about  $4 \mu\text{m}$ , and is exemplarily about  $8 \mu\text{m}$ . The total length of the active core is typically  $5 \text{ mm}$  or more.

Upper cladding layer 50 is advantageously made from phosphosilicate glass, exemplarily by low-pressure chemical vapor deposition. In order to provide the desired index of refraction, an appropriate content of, e.g., phosphorus is selected according to methods well known in the art. An exemplary phosphorus content is about 2 wt.%. The thickness of the upper cladding layer is exemplarily about  $5 \mu\text{m}$ .

In use, an optical signal at a wavelength of about  $1.55 \mu\text{m}$ , and pump radiation at least at one wavelength shorter than  $1.55 \mu\text{m}$ , are coupled into the passive core, and from the passive core into the active core. As is well-known in the art, pump radiation is absorbed by  $\text{Er}^{3+}$  ions in the active core, promoting at least some of them to the  $^4\text{I}_{13/2}$  state, which is a lasing level of atomic excitation. The lasing level is not reached directly, but rather by optical excitation to any one of several excited states of still higher energy. The lasing level is reached by nonradiative decay from those higher states. Correspondingly, pump radiation is effective at any of a group of wavelengths, including 980 nm, 810 nm, 660 nm, 514 nm, and  $1.48 \mu\text{m}$ .

In order for excitation of erbium ions, and resulting amplification, to take place, the signal and pump

radiation must be coupled from the passive core into the active core, and vice versa. With reference to FIG. 2, this is readily achieved by providing the active core with tapers 60. That is, the active core has two terminal portions, each of which is progressively constricted as the corresponding end is approached. The constriction is in at least one dimension normal to the longitudinal axis of the core. The normal dimension may be transverse, as shown in FIG. 2, or, as depicted in FIG. 3, it may be vertical; i.e., normal to the orientation of the deposited layers.

In the preferred embodiment, the tapers 60 are adiabatic; that is, the signal radiation remains in the fundamental mode as it is coupled from the passive to the active core, and again when it is coupled from the active to the passive core. (In the preferred embodiment, the active and passive cores are, of course, single-mode waveguides with respect to the signal radiation.) As is well known in the art, a taper will be adiabatic only if it is relatively gradual. For example, a straight-sided taper in this context will generally be adiabatic if it has a reduction ratio of about 100:1; i.e., the original width (or depth) is constricted, in effect, down to zero over a length that is 100 times the original width (or depth). The length of each tapered region is exemplarily about 1 mm.

Shown in FIG. 3 is a flowchart representing an exemplary sequence of steps in the fabrication of the inventive optical amplifier. The enumeration of the process steps in the following discussion is made with reference to the figure.

In Step A, the lower cladding layer is first formed.

In Step B, a layer corresponding to the passive core is then deposited on the upper surface of the lower cladding layer.

In Step C, the workpiece is annealed in order to at least partially densify the deposited passive core layer. Appropriate annealing conditions will be readily apparent to a skilled practitioner in the art.

In Step D, the passive core is then formed by etching the passive core layer. Dry etching is preferable for this step.

In Step E, the workpiece is annealed in order to flow the passive core, reducing roughness that was caused by etching. Appropriate annealing conditions will be readily apparent to a skilled practitioner in the art.

In Step F, a layer corresponding to the active core is then deposited.

In Step G, the workpiece is annealed, exemplarily at  $600^\circ\text{C}$  for 2 hours in air. The purpose of this annealing step is to stabilize the deposited film (i.e., against subsequent changes in structure, optical properties, and susceptibility to chemical attack).

In Step H, the active core is then formed by etching away a portion of the active core layer. A preferred etching process for Step H is ion milling, because this process is relatively nonselective with regard to the

composition of the material being removed.

In optional Step I, the workpiece is desirably annealed in order to flow the active core, and thereby to reduce surface roughness created during Step H. Appropriate annealing conditions will be readily apparent to a skilled practitioner in the art.

In Step J, the workpiece is then annealed at a temperature of at least about 700°C for a duration of at least about 1 hour in a reactive atmosphere such as very dry oxygen. (An appropriate grade of oxygen for this purpose is research grade, i.e., 99.999% purity.) This step is believed to reduce contaminant levels.

In optional Step K, before the upper cladding layer is deposited, a protective film of an appropriate dielectric material is advantageously formed over the active core in order to prevent contamination of the active core by the upper cladding layer. Such contamination should be avoided because it can reduce the radiative lifetime of the Er<sup>3+</sup> ions below acceptable limits. Protective films that are effective for that purpose can be, e.g., silicon dioxide or phosphorus silicate films formed by sputtering or evaporative deposition. Such a protective film, if used, should be at least about 1000 Å thick.

In Step L, the upper cladding layer is then deposited.

Etching steps D and H are carried out such that after etching is completed the remaining portions of the active and passive core layers describe at least one pair of elongated cores, comprising an active core overlying a passive core. The two cores have a common longitudinal axis. As is apparent in FIGs. 2 and 3, the active core is typically made smaller than the passive core in the longitudinal direction. As seen in FIG. 2, this leads to a pair of terminal passive core portions 70 not overlain by the active core. If the taper is formed with respect to the transverse direction, as shown in FIG. 2, the active core will also typically be smaller than the passive core in the transverse direction. However, if the taper is formed with respect to the vertical direction, as shown in FIG. 3, then the widths (i.e., in the transverse direction) of the active and passive cores are optionally made equal.

As noted above, an exemplary method of depositing the active core layer is by sputtering. According to this method, a glass target of a predetermined composition is provided. The silicon substrate and the target are both placed within a vacuum chamber that is evacuable to a pressure of about  $3 \times 10^{-7}$  torr or less. The chamber is evacuated and oxygen and argon are admitted. A radio-frequency discharge is produced, which leads to evaporation of material from the target and redeposition of such material on the substrate, as is well-known in the art.

As noted above, it is desirable for the deposited active core layer to contain sodium or a similarly-behaving modifier, in order to prevent clustering of the

erbium atoms. Sputtering of sodium-containing glass often has unsatisfactory results because the sodium content of the deposited glass often tends to fall far below the sodium content of the target. However, we have discovered that under appropriate sputtering conditions, the sodium content of the deposited glass can be made relatively close to that of the target. We have found the following conditions in the sputtering chamber to be desirable in that regard: a pressure of 8 - 50  $\mu$ m, and preferably about 27  $\mu$ m; an argon-to-oxygen flow ratio in the range 10:1 to 0.3:1, and preferably about 0.5:1; a substrate temperature that can range freely between about 25°C and about 70°C; and rf frequency of 13.6 MHz and power of about 50 W. We used a target 3 in. (7.6 cm) in diameter and a silicon-wafer substrate 4 in. (10.2 cm) in diameter. The target was situated 1 - 3 in. (2.5 - 7.6 cm) from the substrate, preferably about 3 in. (7.6 cm).

The radiative lifetime of the lasing level of the excited erbium ions is desirably at least about 7 ms. In order to achieve such relatively high lifetimes, it is particularly important to include, during formation of the device, Step J, annealing in a reactive atmosphere.

In use, the signal and the pump radiation are combined and injected into the amplifier, exemplarily by means of directional coupler or wavelength division multiplexer 80, shown in FIG. 2. The amplified signal is extracted, exemplarily by wavelength division demultiplexer 85 of FIG. 2, and unwanted pump radiation that would otherwise contaminate the amplified signal is eliminated, exemplarily by filtering. Such methods are well-known in the art, and need not be described here in detail.

The foregoing discussion is for illustrative purposes only, and is not intended to limit the scope of the invention to a single-pass optical amplifier. For example, a laser or parametric oscillator is readily made by incorporating at least one optical feedback element with the inventive waveguiding structure. An appropriate such element is, e.g., a mirror or a distributed Bragg reflector. Such an arrangement is readily envisioned with reference to FIG. 2, substituting a mirror or Bragg reflector for one or both of elements 80 and 85.

#### EXAMPLE

Erbium-doped glass films, varying in thickness from about 0.8  $\mu$ m at the edge to about 1.5  $\mu$ m at the center, were formed on 4-in. (10.2-cm) diameter silicon wafer substrates by sputter deposition, substantially as described above. In separate trials, three different target compositions were used. The target compositions will be described with reference to the general formula  $\text{SiO}_2(\text{Na}_2\text{O})_a(\text{CaO})_b(\text{Er}_2\text{O}_3)_c$ . The compositions of the resulting, sputter-deposited films will similarly be represented by  $\text{SiO}_2(\text{Na}_2\text{O})_a(\text{CaO})_b(\text{Er}_2\text{O}_3)_c$ .

The first target had  $a=0.27$ ,  $b=0.14$ , and  $c=0.028$ . The resulting sputter-deposited layer had  $a'=0.20$ ,  $b'=0.117$ , and  $c'=0.0275$ . The second target had  $a=0.34$ ,  $b=0.00$ , and  $c=0.033$ , resulting in a deposited layer with  $a'=0.30$  and  $c'=0.036$ . The third target had  $a=0.265$ ,  $b=0.00$ , and  $c=0.038$ , resulting in a deposited layer with  $a'=0.17$  and  $c'=0.032$ . The deposited layers were analyzed by Rutherford backscattering. All three layers had erbium radiative lifetimes of about 10 milliseconds, and densities of about  $6 \times 10^{22}$  atoms per cubic centimeter.

### Claims

1. An optical device, comprising:
  - a) an elongate, active glass core which extends along a longitudinal axis and comprises silicon, oxygen, and erbium, the erbium being at least partially in the form of  $\text{Er}^{3+}$  ions, the active core having a refractive index;
  - b) a glass cladding comprising at least one layer which at least partially surrounds the active core and has a refractive index which is smaller than the core refractive index;
  - c) means for coupling signal radiation, having a signal wavelength, into the active core and means for coupling the signal radiation out of the active core; and
  - d) means for coupling pump radiation into the active core such that pump radiation of an appropriate wavelength will excite at least some of the  $\text{Er}^{3+}$  ions to a lasing level, leading to amplification of the signal radiation by stimulated emission,

CHARACTERIZED IN THAT

  - e) the device further comprises a substrate having a substantially planar principal surface;
  - f) the active core is a body that overlies a portion of the principal surface;
  - g) the cladding comprises a lower cladding layer disposed between the active core and the principal surface, and an upper cladding layer which overlies and partially surrounds the active core;
  - h) the active core further comprises an alkali metal or alkaline earth metal in an effective quantity to prevent clustering of erbium atoms;
  - i) the active core has an erbium-to-silicon atomic ratio of at least about 0.01 and an absolute erbium concentration of at least about  $1.4 \times 10^{20}$  atoms per cubic centimeter, and
  - j) the lasing level has a radiative lifetime of at least about 7 ms.
2. The optical device of claim 1, wherein the substrate comprises a silicon body.
3. The optical device of claim 1, wherein the active core has an erbium-to-silicon atomic ratio of at least about 0.02.
4. The optical device of claim 1, wherein the active glass core is adapted to guide the fundamental mode of the signal wavelength, and the means for coupling the signal radiation into and out of the active core are adapted to couple the signal radiation adiabatically.
5. The optical device of claim 1, wherein the concentration of  $\text{Er}^{3+}$  ions is substantially constant throughout the active core, and the active core is substantially free of radiation damage.
6. The optical device of claim 1, wherein the alkali metal or alkaline earth metal comprises sodium, and the active core has a sodium-to-silicon atomic ratio in the approximate range 0.2 - 0.6.
7. The optical device of claim 1, wherein the alkali metal or alkaline earth metal comprises calcium, and the active core has a calcium-to-silicon atomic ratio of not more than about 0.2.
8. The optical device of claim 4, further comprising an elongate, waveguiding, passive, glass core which extends along the longitudinal axis and is disposed between the lower cladding layer and the active core, the passive core being adapted to guide the fundamental mode of the signal radiation, means for coupling an optical signal and pump radiation into the passive core, and means for coupling signal radiation out of the passive core, wherein:
 

the passive core is substantially free of erbium and has a refractive index that is smaller than the active core refractive index but larger than the upper and lower cladding refractive indices,

the active core includes a central portion and two ends,

and the means for coupling the signal radiation into and out of the active core comprise two further, tapered portions of the active core, each tapered portion extending between the central portion and an end and tapering toward the respective end such that the tapered portion is progressively constricted in at least one direction perpendicular to the longitudinal axis.
9. The optical device of claim 8, wherein the perpendicular direction is substantially parallel to the substrate principal surface.
10. The optical device of claim 8, wherein the perpendicular direction is substantially normal to the

substrate principal surface.

11. The optical device of claim 8, wherein the passive core comprises phosphosilicate glass, the upper cladding layer comprises phosphosilicate glass, and the lower cladding layer comprises thermal silicon dioxide. 5
12. The optical device of claim 1, further comprising at least one optical feedback element, such that the device can function as a laser. 10
13. The optical device of claim 1, further comprising at least one optical feedback element, such that the device can function as a parametric oscillator. 15
14. A method for forming an optical device on a substrate having a substantially planar principal surface, comprising: 20
- a) forming a first layer of vitreous silicon dioxide on the principal surface;
  - b) depositing a second layer of silica-based glass over the first layer by sputtering a target of silica-based glass such that the second layer has a higher refractive index than the first layer, 25
  - c) annealing the second layer such that it is stabilized;
  - d) removing a portion of the second layer by etching, such that an elongate core, extending along the longitudinal axis, is formed, the core being adapted, after completion of the device, to guide electromagnetic radiation of at least a signal wavelength and a pump wavelength; and 30
  - e) depositing a third layer of phosphosilicate glass over the core such that the third layer has a smaller refractive index than the core;
- CHARACTERIZED IN THAT
- f) the target further comprises sodium and erbium; and 40
  - g) the target composition is selected such that the core has an erbium-to-silicon atomic ratio of at least about 0.01, a sodium-to-silicon atomic ratio in the approximate range 0.2 - 0.6, and an absolute erbium concentration of at least about  $1.4 \times 10^{20}$  atoms per cubic centimeter, and the target composition is further selected such that a lasing level is associated with the erbium in the core, the lasing level having a radiative lifetime of at least about 7 ms. 50
15. The method of claim 14, further comprising, after (d) and before (e), the step of forming a protective dielectric film over the core. 55
16. The method of claim 14, further comprising, after
- (d), the step of annealing the core such that roughness due to etching of the second layer is substantially removed.
17. The method of claim 14, further comprising, after (d), the step of annealing the core at a temperature of at least about 700°C for a duration of at least about 1 hour in a reactive atmosphere.
18. A method for forming an optical device on a substrate having a substantially planar principal surface, comprising: 60
- a) forming a first layer of silicon dioxide on the principal surface;
  - b) depositing a second layer of phosphosilicate glass over the first layer such that the second layer has a higher refractive index than the first layer;
  - c) annealing the second layer such that it is at least partially densified;
  - d) removing a portion of the second layer by etching, such that an elongate lower core having a longitudinal axis is formed, the lower core being adapted, after completion of the device, to guide electromagnetic radiation of at least a signal wavelength and a pump wavelength;
  - e) annealing the lower core such that roughness due to etching of the second layer is substantially removed;
  - f) depositing a third layer of silica-based glass over the lower core by sputtering a target of silica-based glass such that the third layer has a higher refractive index than the lower core;
  - g) annealing the third layer such that it is stabilized;
  - h) removing a portion of the third layer by etching, such that an elongate upper core, extending along the longitudinal axis, is formed, the upper core being adapted, after completion of the device, to guide electromagnetic radiation of the signal and pump wavelengths;
  - i) annealing the upper core at a temperature of at least about 700°C for a duration of at least about 1 hour in a reactive atmosphere; and
  - j) depositing a fourth layer of phosphosilicate glass over the upper and lower cores such that the fourth layer has a smaller refractive index than the upper and lower cores; 65
- CHARACTERIZED IN THAT
- k) the target further comprises sodium and erbium; and
  - l) the target composition is selected such that the third layer has an erbium-to-silicon atomic ratio of at least about 0.01, a sodium-to-silicon atomic ratio in the approximate range 0.2 - 0.6, and an absolute erbium concentration of at least about  $1.4 \times 10^{20}$  atoms per cubic cen-

timer, and the target composition is further selected such that a lasing level is associated with the erbium in the third layer, the lasing level having a radiative lifetime of at least about 7 ms.

5

19. The method of claim 18 further comprising, after (i) and before (j), the step of forming a protective dielectric film over the active core.

10

20. The method of claim 17 or claim 18, wherein the reactive atmosphere comprises very dry oxygen.

21. The method of claim 18 a further comprising, after (h), the step of annealing the upper core such that roughness due to etching of the third layer is substantially removed.

15

20

25

30

35

40

45

50

55

8



FIG. 1

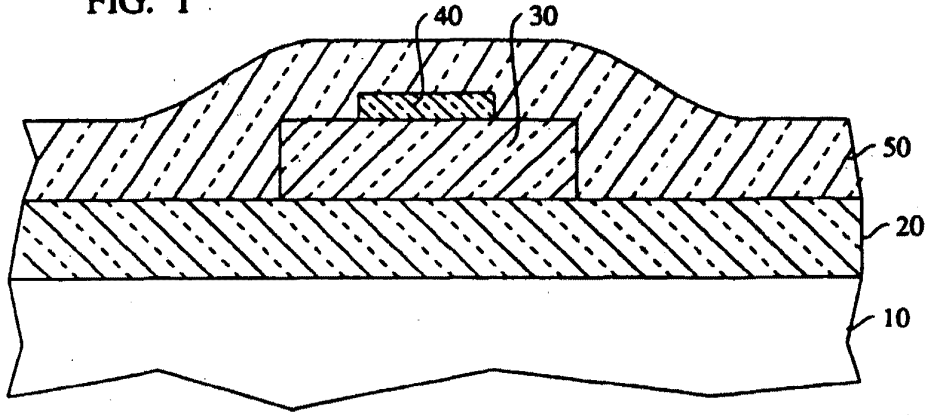


FIG. 2

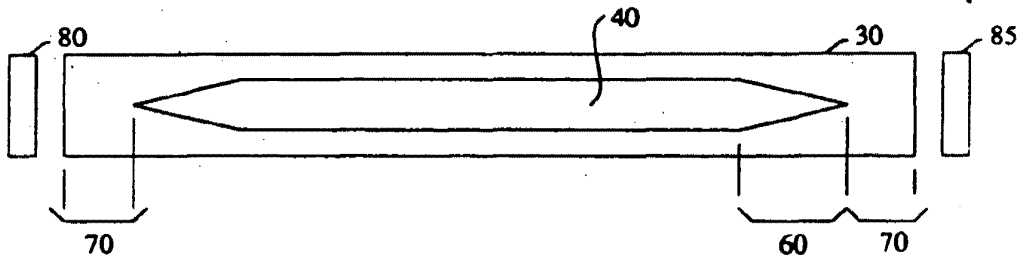


FIG. 3

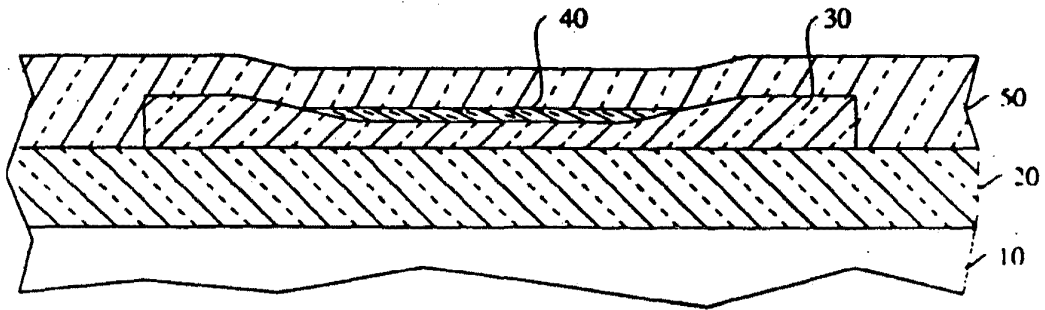
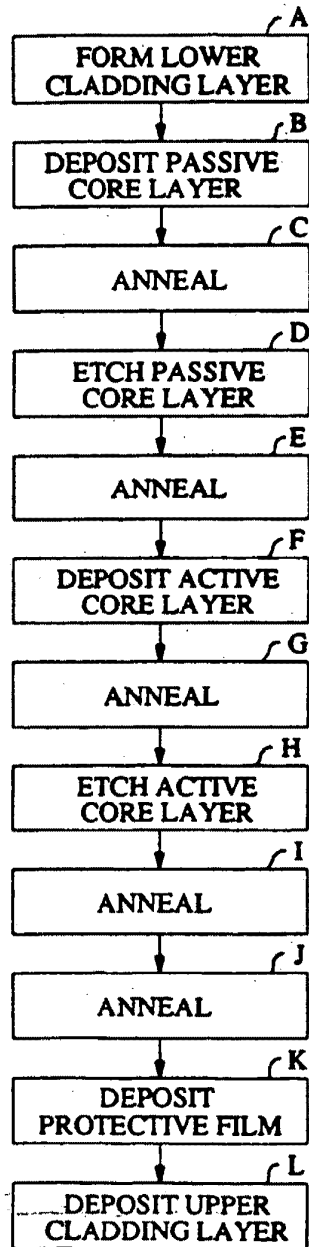


FIG. 4



## Patent Abstracts of Japan

PUBLICATION NUMBER : 07233469  
PUBLICATION DATE : 05-09-95

APPLICATION DATE : 22-02-94  
APPLICATION NUMBER : 06024420

APPLICANT : ASAHI GLASS CO LTD;

INVENTOR : SASAKI KENICHI;

INT.CL. : C23C 14/34 C04B 35/46 C23C 14/08

TITLE : TARGET, ITS PRODUCTION AND PRODUCTION OF HIGH-REFRACTIVE-INDEX FILM

ABSTRACT : PURPOSE: To produce a highly productive oxide sintered compact for a sputtering target having a low resistivity and a high content of oxygen by hot-pressing titanium dioxide powder in a nonoxidizing atmosphere and sintering the compact.

CONSTITUTION: The powder of titanium dioxide having 0.05-40 $\mu$ m grain diameter is hot-pressed at 1000-1300°C and 50-100kg/cm<sup>2</sup> in a nonoxidizing atmosphere of Ar, etc., to obtain an oxide sintered compact consisting essentially of TiO<sub>x</sub> (1<x<2). A sputtering target having  $\leq 10\Omega$ cm resistivity at room temp. and contg.  $\geq 35$ wt.% oxygen is formed from the sintered compact. A metal oxide other than TiO<sub>x</sub> is incorporated, as required, into the target by <50%. The oxide of at least one kind among Cr, Ce, Zr, Y, Nb, Ta, Si, Al and B is preferably used for the metal oxide. DC sputtering is conducted by using the target to form a high-refractive-index uniform transparent film at a high rate.

COPYRIGHT: (C)1995,JPO



## Document Summary




New  
Search



Help

[Preview Claims](#)  
[Preview Full Text](#)  
[Preview Full Image](#)

Email Link: 

**Document ID:** JP 02-054764 A2

**Title:** DEVICE FOR COATING SUBSTRATE WITH INSULATOR

**Assignee:** LEYBOLD AG

**Inventor:** SCHERER MICHAEL  
LATZ RUDOLF  
PATZ ULRICH

**US Class:**

**Int'l Class:** C23C 14/35 A

**Issue Date:** 02/23/1990

**Filing Date:** 06/22/1989

### Abstract:

**PURPOSE:** To prevent the hindrance of the electrification on a target, by superposing the output voltage of an AC power source on the DC voltage of a DC power source and specifying the voltage of the AC power source to be applied on electrodes.

**CONSTITUTION:** The magnetron sputtering device is provided with the AC power source, which outputs voltages to be superposed on the DC voltage of the DC power source. The output of the AC power source impressed on the electrodes connected to the target is regulated to 5 to 20% of the output supplied to the electrodes by the DC power source. A high-frequency power source is used as the AC power source. As a result, an insulator, such as Al<sub>2</sub>O<sub>3</sub>, is deposited on the substrate at a high rate without receiving the hindrance by reactive sputtering.

(C)1990,JPO

⑨ 日本国特許庁(JP)

⑩ 特許出願公開

⑫ 公開特許公報(A)

平2-54764

⑬ Int. Cl.<sup>5</sup>

識別記号

庁内整理番号

⑭ 公開 平成2年(1990)2月23日

C 23 C 14/35

8520-4K

審査請求 未請求 請求項の数 17 (全9頁)

⑮ 発明の名称 基板を絶縁体で被覆する装置

⑯ 特 願 平1-158479

⑰ 出 願 平1(1989)6月22日

優先権主張 ⑱1988年6月23日⑲西ドイツ(DE)⑳P38 21 207.2

⑳ 発 明 者 シェーラー-ミヒヤエル ドイツ連邦共和国 ローデンバツハ D-6458 リンデン  
シュトラーセ 12

㉑ 発 明 者 ラッツ ルドルフ ドイツ連邦共和国 フランクフルト D-6000 マインツ  
アー ラントシュトラーセ 326

㉒ 発 明 者 バツツ ウルリツヒ ドイツ連邦共和国 リンゼンゲリヒト 2 D-6464 ヴ  
アルトシュトラーセ 26

㉓ 出 願 人 レイボルト アクチー ドイツ連邦共和国 ハウナ 1 D-6450 ビルヘルム-  
エンゲゼルシャフト  
ローン-シュトラーセ 25

㉔ 代 理 人 弁理士 鈴木 弘男

明 細 書

1. 発明の名称

基板を絶縁体で被覆する装置

2. 特許請求の範囲

(1) ターゲットに接続された電極に接続された直流電源を有し、前記ターゲットから放出された粒子が基板上に堆積される導入物質との化合物を形成し、前記ターゲットには磁気磁界が印加され、その磁力線は磁極部分においてターゲットの表面から出ていく、基板を絶縁体で被覆する装置において、前記直流電源の直流電圧に重畳される電圧を出力する交流電源を設け、前記電極に印加される前記交流電源の出力を前記直流電源によって前記電極に供給される出力の5%ないし25%にしたことを特徴とする装置。

(2) 前記交流電源が高周波電源である請求項1に記載の装置。

(3) 前記高周波出力は前記直流出力の10%である請求項1または2に記載の装置。

(4) 前記直流電源が第1および第2のインダ

クタを介して前記電極に接続された請求項1に記載の装置。

(5) 前記交流電源がコンデンサを介して前記電極に接続された請求項1に記載の装置。

(6) 前記直流電源と前記第1のインダクタとの間に一端を接地電位にしたコンデンサを接続した請求項4に記載の装置。

(7) 前記第1のインダクタと第2のインダクタとの間に一端を接地電位にしたコンデンサを接続した請求項4に記載の装置。

(8) 第1のコンテナと、この第1のコンテナの中に配置される第2のコンテナとを有し、第2のコンテナはダイヤフラムとしての開口を有し、被覆される基板は前記開口を通して前記ターゲットと対向し、1またはそれ以上の気体が第1および第2のコンテナの間の空間に導入される請求項1に記載の装置。

(9) 前記交流電源が13.56MHzの交流電圧を与える請求項1に記載の装置。

(10) 前記ターゲットはアルミニウムから成

り、前記基板上に堆積される層はAl<sub>2</sub>O<sub>3</sub>から成る請求項1に記載の装置。

(11) 前記ターゲットはドーピングされたたとえば導電性シリコンから成り、前記基板上に堆積される層はSiO<sub>2</sub>から成る請求項1に記載の装置。

(12) 前記ターゲットはアルミニウムから成り、前記基板上に堆積される層はAlNから成る請求項1に記載の装置。

(13) 前記ターゲットはドーピングされたたとえば導電性シリコンから成り、前記基板に堆積される層はSi<sub>3</sub>N<sub>4</sub>から成る請求項1に記載の装置。

(14) 前記直流電圧がターゲット物質の種類に応じて作動され、電流、電圧または出力電力が調整される請求項1に記載の装置。

(15) ターゲットにAl、SiまたはSnが使用されたときは、前記直流電圧が優先的に作動されて電圧が調整される請求項1に記載の装置。

あるため、比較的簡単である。しかし、導電性が全くないかあるいは非常に低い酸化物の層で基板を被覆することは非常に難しい。この困難さにもかかわらず、基板上に酸化物および他の絶縁体を堆積させるためには、直流スパッタリング手段を用いて金属粒子を発生させ、それらを反応的な雰囲気中で酸化物に転化し基板上に堆積させている。

この処理において、金属粒子の酸化物への転化は基板のすぐ近くであってスパッタリング陰極から離れた所で起こる。これは陰極上に酸化物が堆積しそれに伴ってスパッタリング率が低下するのを防ぐためである。それにもかかわらず、実際には陰極に酸化物を全く付着させないことはできず、スパッタリング率は徐々にかなり低下する。

スパッタリングがマグネトロン陰極を用いて行なわれるときは、磁力線の曲率が最大であるところでスパッタリングは最も濃しく、スパッタ陽が発生する。これらの場所における激しいスパッタ

(16) アルゴン/酸素の雰囲気のもとで、Al、Si、Sn、In/Snのターゲットがスパッタリングされるときは、前記直流電圧が作動され電圧が調整される請求項1に記載の装置。

(17) アルゴン/窒素の雰囲気のもとで、Al、Siのターゲットがスパッタリングされるときは、前記直流電圧が作動され電圧が調整される請求項1に記載の装置。

### 3. 発明の詳細な説明

#### (産業上の利用分野)

本発明は、基板を絶縁体で被覆する装置、とくにターゲットに電気的に接続された電極に接続された直流電圧を有し、前記ターゲットから放出され微粉化された粒子が基板上に堆積される化合物を形成し、前記ターゲットには周状磁界が印加され、その磁力線は磁極部分においてターゲットの表面から出ていく装置に関する。

#### (従来技術)

スパッタリングまたは粉状化プロセスを用いて基板を金属で被覆することは、金属が良導電体で

リングは酸化物の堆積を防止する。ターゲットのこれらの部分は全くスパッタリングされないかまたは非常にゆっくり行なわれる。しかし非導電性の誘電体膜が反応的気体の影響のもとで形成される。これらの成長部分は静電的に帯電され、ターゲット表面上の同時放電の開始点となり、結局、ターゲットとプラズマまたはターゲットとターゲットの周りの物質との間の放電の開始点となる。放電中は放電アークを消すために陰極電流を一時的に減少させなければならない。しかし、それによって放電が最終的にやむまで不安定状態が生じる。

直流電流によるマグネトロン・スパッタリングにおいては、純粋な二極管スパッタリングとは対称的にターゲットに反応生成物が部分的に付着するのを防ぐことはできず、せいぜい磁界を最適化して低くおさえることができるだけである。

この問題を解決するための手始めとして、直流電圧の代りに周波数の高い交流電圧をターゲット電極と基板との間に与えることがある。反応的な

真空気下でこの高周波マグネロン・スパッタリングを行えばターゲット表面での放電も起こらないし、静電的な帯電も起こらない。しかしながら、純粋な高周波スパッタリングにおいては、スパッタリング率が比較的低い。

しかし、高周波電圧を重ねた直流電圧を用い、基板上にタンタルおよびタンタル酸化物を堆積させるスパッタリング処理も知られている (F. Vratny「高周波を重ねた直流スパッタリングによるタンタルおよびタンタル酸化物の堆積」1968年10月7日～11日得脱誘電体に関する会議資料、J. Electrochem. Soc. 114-5, 505, 1967からの複製)。直流電流と交流電流が結合された電界はプラズマ密度を高め、反応的スパッタリング中に陰極上に誘電体膜が形成されるのを防止する。それにより、0.5～2ミリのスパッタリング圧力下で約80人/分のタンタル堆積率を達成することができ、10～20ミリの圧力下ではタンタル堆積率を2倍に増大させることができる。純粋な酸素の下における反応的スパッタリ

る10caである。電子の平均自由路長が電極間の距離より短い圧力のもとで電界の周波数が気体の衝突周波数より低いときは、電子は各々振動して数回衝突し、電界の位相に合わせて移動しようとする。この例としては低周波交流スパッタリングおよび低周波直流/交流スパッタリングがある。このとき電子は連続して陰極および基板に突入する。高い周波数では電子は気体の衝突の間で小さな振幅で多く振動することができる。この場合電子は静止しているように見え、その結果強力なプラズマができる。このプラズマは重畳された直流電界で引き上げることができる。さらに高い周波数たとえばマイクロ波の範囲では、電子は電気的および磁氣的成分を有する定在波の影響を受ける。この影響のため、電子は空間の条件たとえば電極寸法の間数および定在波を発生する周波数などに応じて空間中で分散する。

さらに、高周波電界があるため、電気的な負性気体による反応的スパッタリング中に陰極上に誘電体の被覆が堆積するのを防止する。イオン濃度

の過程では、TaO<sub>2</sub>およびMnO<sub>2</sub>を被覆するのに50～100人/分の堆積率が得られる。

この堆積率の増加は、高周波電界においては帯電粒子が振動運動を行なうという事実によって説明することができる。重畳電界の影響により移動する電子は直流電界中における電子よりも長い距離を移動する。この長い移動距離は電子と気体原子との衝突の確率を増加させ、これは与えられた圧力下での陰極への正イオンの投入速度を増加させることになる。このことはスパッタリング率および層堆積を増加させる効果をもつ。気体中で電子がどのように反応するかは、気体圧力すなわち電子の自由路長、高周波電界の周波数および電極配置に依存する。低い圧力のもとでは、平均自由路長が電極間の距離より長ければ、電子は励起されてほとんど気体との衝突なしに電極間を移動する。たとえば10ミリの圧力のもとではアルゴン中の電子は0.4eVのエネルギーを有し、平均自由路長は従来の電極間の距離とほぼ一致す

は高周波電界を通して維持され、陰極への電子の衝突は大量の絶縁被覆が形成される可能性を減少させる。イオン化の確率が増え、気体の絶縁破壊強度が小さくなることにより、高周波電界においては二極管スパッタリング中の通常の圧力より低いスパッタリング圧力のもとで作用することができる。

上述した公知の装置は二極管スパッタリングあるいは二極管粉状化に関するものである。それはまた直流および交流電圧を電極に印加する公知の装置にも言えることである。しかし、二極管スパッタリングは仮に交流の重ね合せを利用したとしても多くの適用例において堆積率が低いという欠点がある。マグネロン陰極を用いた上記スパッタリングは実質的に高いスパッタリング率を有する。

マグネロン・スパッタリングとマイクロ波放射を結合することもまた公知である (米国特許4610770号=ヨーロッパ特許0148504号)。この場合のマイクロ波放射は、マグネ

ロン電極の環状力線が位置している所だけターゲットがスパッタリングされないのを防止しようとするものである。このようにスパッタリング率を上昇させ、ターゲットの腐食を狭い限られた部分だけでなく防止するために、スパッタリング領域をかなり増加させる。この目的を達するために、同軸状に配置された2個の永久磁石を用いてミラー磁界を発生させる。このとき磁石間では磁力線が拡散し、磁石の近くでは再び収縮する磁束分布となる。この場合の欠点は中空の誘電管または同等の手段を用いたマイクロ波の放射が高価であること、また永久磁石の構造が複雑であることである。

さらに、基板ホルダとターゲットホルダが高周波の高電圧電源と接続され、 $-30V$ から $-100V$ 好ましくは $-70V \pm 10V$ のバイアス電圧がスパッタリング手段によって得たドープ金属層を製造する方法が知られている(ドイツ特許2909804号)。この方法は電気的性質が正確に定量化された抵抗層の再現可能な堆積に関する

#### (発明の目的および構成)

本発明は永久磁石の磁力線が環状に形成されてスパッタリングされる物質に印加される従来のマグネトロン・スパッタリング装置において、ターゲット上の帯電が妨げられるのを防止することを目的とする。

この目的を達するために、直流電源の直流電圧に交流電源の出力電圧を重ね、電極に与えられる交流電源の電圧を、直流電源によって電極に与えられる電圧の5%ないし25%にするように構成した。

本発明によって得られる利点は、 $SiO_2$ 、 $Al_2O_3$ 、 $Si_3N_4$ 、または $AlN$ などの絶縁体を従来のマグネトロン陰極を用いた反応的スパッタリングを使って何ら妨害を受けることなく高い率で堆積できるということである。

反応的直流スパッタリングの全ての利点は保有されている。なぜなら、重畳高周波成分はターゲット上の電位差を減少させ、それによりターゲット上で帯電効果を妨害することは避けられ

るもので、ここでは上記抵抗層は純粋な二極管高周波スパッタリングによって製造される。この公知の方法は良導電体である化合物が放出されるので、アークの問題に関するものでなく、さらに直流電源も使用されない。

さらに、中和装置を有するイオンビーム処理装置が知られている。この装置では基板ホルダおよび/またはターゲット上の電荷が不確定な状態になるのを避けるため、中和装置が熱放出電子の形成で使用され、さらに正電位が基板および/またはターゲットに印加される。反応的スパッタリングの問題とくに絶縁体の反応的スパッタリングの問題については触れていない。

アルミニウムをエッチングする別の二極管方法によれば、直流電源および高周波発生器が並列に接続され、これらの共通の出力電圧は2つの相対する電極に印加される(ドイツ特許3140675号)。このケースの場合も運動量の伝達による反応的なスパッタリングの問題は述べられていない。

このため永久アークにより放電が終了することが保証される。このことは高周波成分が、第1にプラズマ密度を増加させることによってスパッタリング率を増加させ、第2にターゲットの非導電領域から離れたスパッタリングに役立つという意味ではない。むしろ反応的マグネトロン・スパッタリング中に不可避免的に形成される非導電性のターゲット部分上に帯電効果の妨害を生じさせないということである。このため、直流電圧はターゲット上の帯電効果の妨害を避けるように高周波電圧によって変調される。

#### (実施例)

以下、本発明の一実施例を図面に基づいて詳細に説明する。

第1図には基板1が示され、この基板1には絶縁体の薄い層2が設けられる。基板1に対向してスパッタリングされるべきターゲット3が配置されている。ターゲット3は断面がU形時のエレメント4を介して電極5と接続されている。電極5はヨーク6上に接地され、ヨーク6とエレメント



4との間には永久磁石7, 8, 9が設けられている。

永久磁石7, 8, 9の磁極は、外側の2つの永久磁石7および9のS極と其中の永久磁石8のN極がターゲット3を通してほぼ円弧状の磁界を形成するように、ターゲット3に交互に向けられている。この磁界はターゲット3の前のプラズマを圧縮して、磁界がその円弧の最高点のところで磁界の密度が最大になる。プラズマ中のイオンは、直流電圧10から供給される直流電圧により形成される電界によって加速される。直流電圧10のマイナス極は2個のインダクタ11および12を介して電極5に接続されている。電界はターゲット3の表面と垂直に形成され、プラズマの正イオンはターゲット3の方向に加速される。これによって、多数の原子や粒子がターゲット3から放出される。とくに領域13および14から放出され、そこで磁界は最大となる。放出された原子または粒子は基板1の方向へ移動し、薄い層2となって堆積される。

クタ35の一端が接続され、その他端は接地されている。インダクタ11および12の接続点はコンデンサ32に接続され、コンデンサ32は接地されている。高周波電圧30の第2の端子36も接地されている。

コンデンサ29および32とその間に接続されたインダクタ11とによって高周波の通過を助けるローパスフィルタを形成している。インダクタ12によってその効果をさらに強めている。コンデンサ33および34とインダクタ35によって高周波を陰極5に印加する回路を形成している。これらは同時にバイパスフィルタとして機能する。すなわち直流電圧は高周波電圧30には印加されない。

第1図の装置における気体は実際には第1および第2のコンテナ25および24の間の空間に入るが、それは陰極5の周りのガス分配システムを通して第2のコンテナ24へ導入することもできる。

第1図の装置を制御するために、測定データお

ターゲット物質が金属であって基板上に酸化膜を被覆するときは、ターゲット3から放出された粒子は空間15において特定の気体と反応する。この気体はガスタンク16および17からバルブ18, 19およびパイプ22, 23を経て、入口弁20, 21を介して空間15に導入される。この空間15は2つのコンテナ24および25によって形成され、コンテナ25は基板1を収容し、他方のコンテナ24は基板1の前で終わり、ダイヤフラム26を形成している。コンテナ24, 25およびコンテナ25の底に設置された基板1は共に接地されている。直流電圧10の第2の極27もまた接地され、第1の極28はインダクタ11および12から離れてコンデンサ29に接続され、コンデンサ29は接地されている。

さらに、端子31を有する高周波電圧30は直流電圧10のそばにあって、可変コンデンサ33および34を介して電極5に接続されている。可変コンデンサ33および34の接続点にはインダ

および出力制御命令を処理する処理制御コンピュータが用いられる。この処理制御コンピュータにたとえば処理室25内の分圧の測定値が与えられる。これらのデータおよび他のデータに基づいて、コンピュータはたとえばバルブ18および19を通して流入する気体を制御し、陰極5における直流と交流の電圧の割合を設定する。処理制御コンピュータは他の全ての変数たとえば陰極電流、高周波出力および磁電強度を制御することができる。このような処理制御コンピュータはよく知られているので、その構成についての説明は省略する。

第1図には高周波の供給がどのように調整されるか示されていない。しかし、特定の値を予め設定し出力が常にこの設定値に調整されるように調整回路を構成することは公知である。

第2図は直流だけによるスパッタリング中に生じた過程を示す図である。これらの過程は以下に説明する本発明による装置の実施例の作用を理解する上で重要である。第2図は気体圧力が $7 \times$

10<sup>-3</sup>ミリバールのアルゴンの純不活性ガスの雰囲気下のものであり、この図から直流陰極電流は明らかに直流陰極電圧の関数であることがわかる。電圧の上昇に伴ない導電性プラズマが形成されて抵抗値が減少するので、電流  $J = f(U)$  はほぼ放物線状に増加する。スパッタリング率  $R$  は  $\mu\text{m/s}$  で表わされ、スパッタリング出力の増加に伴ない直線的に上昇し、直線  $R = f(P_{\text{cat}})$  によって表わされる。出力密度  $10\text{ W/cm}^2$  に対応するスパッタリング出力が  $440\text{ W}$  のとき、スパッタリング率は  $50\ \mu\text{m/s}$  である。

第3図には、陰極電圧の関数としての陰極電流および直流のときに予め設定したアルゴンおよび酸素流入の場合における酸素分圧と陰極電圧の相関が示されている。第3図の測定曲線は酸素の流量  $f_{\text{O}_2}$  が  $6.7\text{ SCCM/分}$  で一定のときに記録されたものである。ここで  $\text{SCCM/分}$  は標準的な  $\text{cm}^3/\text{分}$  と一致する。

第2図とは対照的に、第3図は反応的な直流スパッタリング時の状態を示している。電流-電圧

特性の範囲(約  $300\text{ V}$  ないし  $400\text{ V}$  の範囲)が不安定な範囲であることであり、その中で時々火花やプラズマ損失が起こる。したがって動作点を早く動かして放電が止まらないようにしなければならない。

すでに述べたように、陰極電流  $J$  は明らかに陰極電圧の関数であり、各々の電圧値には確実に1つの電流値が対応する。しかし、その逆は言えない。もし第3図の縦軸と横軸を交換し、縦軸に電圧  $U$  をとり、横軸に電流  $J$  をとると、電圧曲線は1つの電流値が2つの電圧値をとるS字形を描く。

第4図には酸素分圧および直流電流の陰極電圧の関数としての放電電流が第3図と同じ条件のもとで示されているが、今度は高周波変調された陰極電圧が使用されている。ここでの変調周波数は  $13.56\text{ Hz}$  であり、高周波の振幅は  $140\text{ V}$ 、陰極における有効電力は一定で  $20\text{ W}$  である。吸収のない  $\text{Al}_2\text{O}_3$  の層は  $425\text{ V}$  以下で得られ、これは第3図の純直流電流の場合と似て

特性から電圧を増加させたときの電流  $J$  は依然として明らかに電圧の関数であることがわかる。電圧を増加させると電流は初め非常に急激に上昇するが、その後最大値に達し、そこから減少し次いで再びいく分増加する。しかし、電圧を約  $600\text{ V}$  の高電圧から減少させると、電流は初め電圧の減少に伴ない減少する。しかし、最初の金属ターゲットの状態を仮定すると、電圧がさらに下がると電流は大きく上昇し、このとき基板上的酸化物の形成は増加していることがわかる。 $350\text{ V}$  以下になると、電流は再び急に減少し、酸素分圧が大きく上昇する。約  $450\text{ V}$  から  $350\text{ V}$  までの範囲では、ターゲット上に堆積する  $\text{Al}_2\text{O}_3$  の2次電子発生量は、アルゴンイオンの衝撃によって上昇する。これとは対照的に、 $350\text{ V}$  以下においてはターゲットは酸素分子で被覆されターゲット上に  $\text{Al}_2\text{O}_3$  が形成されることはない。この酸素分子はアルゴンの衝突イオンによって放出され、2次電子効果は低下する。反応的直流動作の欠点は、基板上に吸収のない層を形成する陰

極電圧の範囲(約  $300\text{ V}$  ないし  $400\text{ V}$  の範囲)が不安定な範囲であることであり、その中で時々火花やプラズマ損失が起こる。したがって動作点を早く動かして放電が止まらないようにしなければならない。

すでに述べたように、陰極電流  $J$  は明らかに陰極電圧の関数であり、各々の電圧値には確実に1つの電流値が対応する。しかし、その逆は言えない。もし第3図の縦軸と横軸を交換し、縦軸に電圧  $U$  をとり、横軸に電流  $J$  をとると、電圧曲線は1つの電流値が2つの電圧値をとるS字形を描く。

第4図には酸素分圧および直流電流の陰極電圧の関数としての放電電流が第3図と同じ条件のもとで示されているが、今度は高周波変調された陰極電圧が使用されている。ここでの変調周波数は  $13.56\text{ Hz}$  であり、高周波の振幅は  $140\text{ V}$ 、陰極における有効電力は一定で  $20\text{ W}$  である。吸収のない  $\text{Al}_2\text{O}_3$  の層は  $425\text{ V}$  以下で得られ、これは第3図の純直流電流の場合と似て

いる。しかし、放電は完全に安定しておりアークはない。実験では約  $420\text{ V}$  の動作点において、放電は火花が起こることなく数時間行なわれた。 $500\text{ V}$  から  $350\text{ V}$  の間では第3図および第4図の電圧-電流特性は数パーセント以内の偏差で一致している。第3図と比べると、第4図で観察することができる連続した強い電流の増加は次のように説明できよう。すなわち、高周波成分は初めターゲット表面上の酸素分子の吸収を防止するが、2次電子の発生量の増加は邪魔されない。2次電子が増加すると確かに衝突によるイオン化を通してイオン流量が増加するが、初めは陰極からの電子流量が増加することによってイオン流量が増加する。この効果は動作範囲を広げスパッタリング率は電圧の低下に伴ないわずかにしか変化しない。この電圧低下は酸素分圧の比較的わずかな増加によって示される。 $420\text{ V}$  の動作点では  $\text{Al}_2\text{O}_3$  のスパッタリング率は約  $470\text{ W}$  の電力で  $25\ \mu\text{m/s}$  であり、これは純粋な金属の場合と比較すると半分に低下しただけである。 $280$