



(12) **United States Patent**  
**Kaplan et al.**

(10) **Patent No.:** **US 6,473,404 B1**  
(45) **Date of Patent:** **\*Oct. 29, 2002**

(54) **MULTI-PROTOCOL TELECOMMUNICATIONS ROUTING OPTIMIZATION**

(75) Inventors: **Allen D. Kaplan**, Miami Beach, FL (US); **William F. McCarthy**, Erie, PA (US)

(73) Assignee: **Connect One, Inc.**, Miami, FL (US)

(\*) Notice: Subject to any disclaimer, the term of this patent is extended or adjusted under 35 U.S.C. 154(b) by 0 days.

This patent is subject to a terminal disclaimer.

(21) Appl. No.: **09/665,399**

(22) Filed: **Sep. 20, 2000**

**Related U.S. Application Data**

(63) Continuation of application No. 09/198,687, filed on Nov. 24, 1998, now Pat. No. 6,144,641.

(51) **Int. Cl.**<sup>7</sup> ..... **H04L 12/56**

(52) **U.S. Cl.** ..... **370/238; 370/252; 370/463; 370/465**

(58) **Field of Search** ..... 370/238, 229, 370/230, 232, 233, 248, 252, 253, 259, 250, 351, 465, 466, 401, 463; 379/201, 219, 220, 221, 242, 243

(56) **References Cited**

**U.S. PATENT DOCUMENTS**

4,054,756 A	10/1977	Comella et al.	179/18
4,100,377 A	7/1978	Flanagan	179/15
4,112,258 A	9/1978	Alles	179/15
4,484,326 A	11/1984	Turner	370/60
4,566,095 A	1/1986	Devault et al.	370/60
4,616,359 A	10/1986	Fontenot	370/60
4,630,259 A	12/1986	Larson et al.	370/60
4,630,261 A	12/1986	Irvin	370/81
4,646,287 A	2/1987	Larson et al.	370/60

(List continued on next page.)

**FOREIGN PATENT DOCUMENTS**

DE	0 581 087 A1	7/1992	
EP	0274793 A1	7/1988	..... H04L/11/20
EP	0418813 A2	3/1991	..... H04L/12/56
EP	0631457 A3	12/1994	..... H04Q/11/04
EP	0641133 A2	3/1995	..... H04Q/3/5445

(List continued on next page.)

**OTHER PUBLICATIONS**

*The Phone Zone—Comparative Analysis of PC Based PBX Systems*, <http://www.phonezone.com/phone-compare-htm>, Oct. 1, 1996.

*Signalling System No. 7*, <http://www.datakinetics.co.uk/ss7.htm>, Oct. 30, 1997.

(List continued on next page.)

*Primary Examiner*—Ricky Ngo

(74) *Attorney, Agent, or Firm*—Haynes and Boone, LLP

(57) **ABSTRACT**

A telecommunications switching system employing multi-protocol routing optimization which utilizes predetermined and measured parameters in accordance with a set of user priorities in determining the selection of a telecommunications path to be utilized for transmitting a data file to a remote destination. The switching system has a first memory for storing the data file to be transferred, a second memory for storing predetermined parameters such as cost data associated with each of the telecommunications paths, a third memory for storing a set of user priorities regarding the transmission of data files, and means for measuring the value of variable parameters such as file transfer speed associated with each of the telecommunications paths. Processor means are operatively associated with the second and third memories and the variable parameter measuring means for determining which of the plurality of telecommunications paths should be utilized for transferring the data file in accordance with the set of user priorities, the predetermined telecommunications path parameters, and the measured variable parameters. The switching system further comprises input means for allowing a user to change the user priorities in the third memory prior to transmitting a file.

**69 Claims, 2 Drawing Sheets**

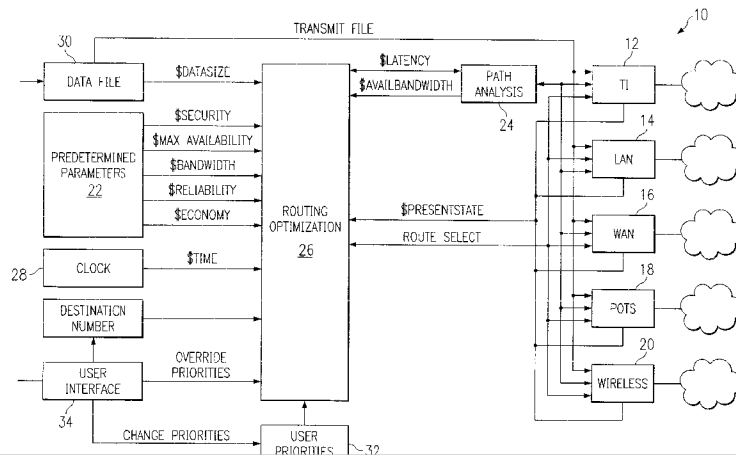

U.S. PATENT DOCUMENTS

4,653,045 A	3/1987	Stanley et al. ....	179/18	5,479,401 A	12/1995	Bitz et al. ....	370/60.1
4,679,190 A	7/1987	Dias et al. ....	370/60	5,483,586 A	1/1996	Sussman ....	379/201
4,703,477 A	10/1987	Adelmann et al. ....	370/94	5,483,587 A	1/1996	Hogan et al. ....	379/202
4,769,810 A	9/1988	Eckberg, Jr. et al. ....	370/60	5,488,651 A	1/1996	Giler et al. ....	379/100
4,769,811 A	9/1988	Eckberg, Jr. et al. ....	370/60	5,491,693 A	* 2/1996	Britton et al. ....	370/401
4,771,425 A	9/1988	Baran et al. ....	370/85	5,495,484 A	2/1996	Self et al. ....	370/110.1
4,813,037 A	3/1989	Debuyscher et al. ....	370/60	5,495,521 A	2/1996	Rangachar ....	379/95
4,870,678 A	9/1989	Adachi ....	379/100	5,509,000 A	4/1996	Oberlander ....	370/17
4,907,724 A	3/1990	Wing, Jr. et al. ....	222/105	5,511,111 A	4/1996	Serbetcioglu et al. ....	379/67
4,969,184 A	11/1990	Gordon et al. ....	379/100	5,519,758 A	5/1996	Tabbane ....	379/59
4,972,464 A	11/1990	Webb et al. ....	379/112	5,521,719 A	5/1996	Yamada ....	358/438
4,979,100 A	12/1990	Makris et al. ....	364/200	5,521,924 A	5/1996	Kakuma et al. ....	370/94.2
4,979,206 A	12/1990	Padden et al. ....	379/67	5,524,137 A	6/1996	Rhee ....	379/67
4,994,926 A	2/1991	Gordon et al. ....	358/400	5,526,353 A	6/1996	Henley et al. ....	370/60.1
4,996,707 A	2/1991	O'Malley et al. ....	379/100	5,526,416 A	6/1996	Dezonno et al. ....	379/265
5,012,511 A	4/1991	Hanle et al. ....	379/211	5,528,677 A	6/1996	Butler et al. ....	379/196
5,018,191 A	5/1991	Catron et al. ....	379/100	5,530,904 A	6/1996	Koga ....	395/872
5,029,196 A	7/1991	Morganstein ....	379/67	5,539,884 A	7/1996	Robrock, II ....	395/200.12
5,068,888 A	11/1991	Scherk et al. ....	379/100	5,541,917 A	7/1996	Farris ....	370/60.1
5,115,495 A	5/1992	Tsuchiya et al. ....	395/200	5,541,927 A	7/1996	Kristol et al. ....	370/94.2
5,117,422 A	5/1992	Hauptschein et al. ....	370/95.1	5,541,930 A	7/1996	Klingman ....	370/110.1
5,146,348 A	9/1992	Kaneyama ....	358/407	5,548,506 A	8/1996	Srinivasan ....	364/401
5,146,488 A	9/1992	Okada et al. ....	379/88	5,551,025 A	8/1996	O'Reilly et al. ....	395/600
5,150,357 A	9/1992	Hopner et al. ....	370/68.1	5,553,124 A	9/1996	Brinskele ....	379/112
5,159,624 A	10/1992	Makita ....	379/57	5,553,131 A	9/1996	Minervino, Jr. et al. ....	379/221
5,163,042 A	11/1992	Ochiai ....	370/17	5,559,721 A	9/1996	Ishii ....	364/514
5,170,266 A	12/1992	Marsh et al. ....	358/468	5,561,670 A	10/1996	Hoffert et al. ....	370/94.1
5,193,110 A	3/1993	Jones et al. ....	379/94	5,561,840 A	10/1996	Alvesalo et al. ....	455/33.1
5,204,894 A	4/1993	Darden ....	379/88	5,563,390 A	10/1996	Pester, III ....	379/34
5,210,743 A	5/1993	Eilenberger et al. ....	370/60	5,563,882 A	10/1996	Bruno et al. ....	370/62
5,233,604 A	8/1993	Ahmadi et al. ....	370/60	5,563,930 A	10/1996	Pester, III ....	379/34
5,241,588 A	8/1993	Babson, III et al. ....	379/201	5,574,780 A	11/1996	Andruska et al. ....	379/207
5,247,571 A	9/1993	Kay et al. ....	379/207	5,579,472 A	11/1996	Keyworth, II et al. ....	395/326
5,268,957 A	12/1993	Albrecht ....	379/67	5,590,127 A	12/1996	Bales et al. ....	370/260
5,274,625 A	12/1993	Derby et al. ....	370/17	5,590,171 A	12/1996	Howe et al. ....	379/33
5,287,199 A	2/1994	Zoccolillo ....	358/402	5,590,181 A	12/1996	Hogan et al. ....	379/114
5,289,536 A	2/1994	Hokari ....	379/221	5,602,909 A	2/1997	Carkner et al. ....	379/207
5,311,583 A	5/1994	Friedes et al. ....	379/209	5,604,682 A	2/1997	McLaughlin et al. ....	364/514
5,323,389 A	6/1994	Bitz et al. ....	379/100	5,604,737 A	2/1997	Iwami et al. ....	370/352
5,323,450 A	6/1994	Goldhagen et al. ....	379/100	5,608,446 A	3/1997	Carr et al. ....	348/6
5,329,635 A	7/1994	Wadin et al. ....	455/33.2	5,608,786 A	3/1997	Gordon ....	379/100
5,333,266 A	7/1994	Boaz et al. ....	395/200	5,610,910 A	3/1997	Focsaneanu et al. ....	370/351
5,337,352 A	8/1994	Kobayashi et al. ....	379/234	5,617,422 A	4/1997	Litzenberger et al. ....	370/401
5,384,835 A	1/1995	Wheeler et al. ....	379/96	5,619,555 A	4/1997	Fenton et al. ....	379/67
5,390,169 A	2/1995	Bernstein ....	370/55	5,623,601 A	4/1997	Vu ....	395/187.01
5,390,339 A	2/1995	Bruckert et al. ....	455/33.2	5,625,404 A	4/1997	Grady et al. ....	348/7
5,396,536 A	3/1995	Yudkowsky ....	379/52	5,625,407 A	4/1997	Biggs et al. ....	348/16
5,396,542 A	3/1995	Alger et al. ....	379/67	5,625,677 A	4/1997	Feiertag et al. ....	379/93
5,402,478 A	3/1995	Hluchyj et al. ....	379/221	5,625,682 A	4/1997	Gray et al. ....	379/266
5,406,557 A	4/1995	Baudoin ....	370/61	5,627,886 A	5/1997	Bowman ....	379/111
5,425,085 A	6/1995	Weinberger et al. ....	379/112	5,633,916 A	5/1997	Goldhagen et al. ....	379/67
5,425,091 A	6/1995	Josephs ....	379/201	5,636,216 A	6/1997	Fox et al. ....	370/402
5,428,608 A	6/1995	Freeman et al. ....	370/60.1	5,640,387 A	6/1997	Takahashi et al. ....	370/359
5,440,620 A	8/1995	Slusky ....	379/100	5,646,982 A	7/1997	Hogan et al. ....	379/89
5,444,707 A	8/1995	Cerna et al. ....	370/94.1	5,651,002 A	7/1997	Van Seters et al. ....	370/392
5,448,633 A	9/1995	Jamaleddin et al. ....	379/201	5,651,006 A	7/1997	Fujino et al. ....	370/408
5,450,411 A	9/1995	Heil ....	370/94.2	5,652,787 A	7/1997	O'Kelly ....	379/112
5,452,289 A	9/1995	Sharma et al. ....	370/32.1	5,654,250 A	8/1997	Va Der Veer et al. ....	502/162
5,452,351 A	9/1995	Yamamoto ....	379/221	5,654,957 A	8/1997	Koyama ....	370/355
5,459,717 A	10/1995	Mullan et al. ....	370/54	5,657,250 A	8/1997	Park et al. ....	370/359
5,459,775 A	10/1995	Isono et al. ....	379/93	5,661,790 A	8/1997	Hsu ....	379/209
5,463,577 A	10/1995	Oowaki et al. ....	365/63	5,661,791 A	8/1997	Parker ....	379/211
5,469,500 A	11/1995	Satter et al. ....	379/201	5,661,792 A	8/1997	Akinpelu et al. ....	379/221
5,471,519 A	11/1995	Howe et al. ....	379/67	5,668,857 A	9/1997	McHale ....	379/93.01
5,471,644 A	11/1995	Schatz et al. ....	455/33.2	5,673,263 A	9/1997	Basso et al. ....	370/396
5,473,608 A	12/1995	Gagne et al. ....	370/85.13	5,675,507 A	10/1997	Bobo, II ....	364/514
5,473,679 A	12/1995	La Porta et al. ....	379/201	5,675,741 A	10/1997	Aggarwal et al. ....	395/200.12
5,475,689 A	12/1995	Kay et al. ....	370/95.3	5,680,392 A	10/1997	Semaan ....	370/261
5,475,732 A	12/1995	Pester, III ....	379/34	5,689,550 A	11/1997	Garson et al. ....	379/89
				5,689,553 A	11/1997	Ahuja et al. ....	379/202

5,695,507 A	12/1997	Auth et al. ....	606/159	5,813,007 A	9/1998	Nielsen .....	707/10
5,699,089 A	12/1997	Murray .....	345/146	5,818,836 A	10/1998	DuVal .....	370/389
5,699,352 A	12/1997	Kriete et al. ....	370/262	5,828,370 A	10/1998	Moeller et al. ....	345/328
5,701,295 A	12/1997	Bales et al. ....	370/271	5,828,837 A	10/1998	Eikeland .....	395/200.32
5,703,935 A	12/1997	Raissy et al. ....	379/88	5,835,579 A	11/1998	Gersi et al. ....	379/100.17
5,703,942 A	12/1997	Pinard et al. ....	379/207	5,835,720 A	11/1998	Nelson et al. ....	395/200.54
5,708,697 A	1/1998	Fischer et al. ....	379/67	5,838,681 A	11/1998	Bonomi et al. ....	370/395
5,710,884 A	1/1998	Dedrick .....	395/200.47	5,838,682 A	11/1998	Dekelbaum et al. ....	370/401
5,712,903 A	1/1998	Bartholomew et al. ....	379/89	5,838,683 A	11/1998	Corley et al. ....	370/408
5,712,906 A	1/1998	Grady et al. ....	379/93.17	5,839,063 A	11/1998	Lee .....	455/410
5,712,907 A	1/1998	Wegner et al. ....	379/112	5,844,600 A	12/1998	Kerr .....	348/17
5,717,745 A	2/1998	Vijay et al. ....	379/112	5,844,972 A	12/1998	Jagadish et al. ....	379/114
5,724,355 A	3/1998	Bruno et al. ....	370/401	5,848,143 A	12/1998	Andrews et al. ....	379/219
5,724,412 A	3/1998	Srinivasan .....	379/93.23	5,848,415 A	12/1998	Guck .....	707/10
5,726,984 A	3/1998	Kubler et al. ....	370/349	5,850,388 A	12/1998	Anderson et al. ....	370/252
5,727,129 A	3/1998	Barrett et al. ....	395/12	5,850,433 A	12/1998	Rondeau .....	379/201
5,729,544 A	3/1998	Lev et al. ....	370/352	5,850,442 A	12/1998	Muftic .....	380/21
5,729,599 A	3/1998	Plomondon et al. ....	379/211	5,850,518 A	12/1998	Northrup .....	395/200.33
5,732,078 A	3/1998	Arango .....	370/355	5,854,893 A	12/1998	Ludwig et al. ....	395/200.34
5,737,320 A	4/1998	Madonna .....	370/258	5,856,974 A	1/1999	Gervais et al. ....	370/392
5,737,333 A	4/1998	Civanlar et al. ....	370/352	5,859,967 A	1/1999	Kaufeld et al. ....	395/186
5,737,395 A	4/1998	Iribarren .....	379/88	5,862,203 A	1/1999	Wulkan et al. ....	379/114
5,737,701 A	4/1998	Rosenthal et al. ....	455/411	5,862,223 A	1/1999	Walker et al. ....	380/25
5,740,230 A	4/1998	Vaudreuil .....	379/88	5,862,325 A	1/1999	Reed et al. ....	395/200.31
5,740,231 A	4/1998	Cohn et al. ....	379/89	5,864,609 A	1/1999	Cross et al. ....	379/115
5,742,668 A	4/1998	Pepe et al. ....	379/58	5,865,223 A	2/1999	Cornford .....	141/88
5,742,670 A	4/1998	Bennett .....	379/142	5,867,494 A	2/1999	Krishnaswamy et al. ...	370/352
5,742,674 A	4/1998	Jain et al. ....	379/209	5,867,495 A	2/1999	Elliott et al. ....	370/352
5,742,762 A	4/1998	Scholl et al. ....	395/200.3	5,867,562 A	2/1999	Scherer .....	379/88
5,742,905 A	4/1998	Pepe et al. ....	455/461	5,867,571 A	2/1999	Borchering .....	379/230
5,745,556 A	4/1998	Ronen .....	379/127	5,870,557 A	2/1999	Bellovin et al. ....	395/200.54
5,745,702 A	4/1998	Morozumi .....	395/200.79	5,872,926 A	2/1999	Levac et al. ....	395/200.36
5,749,075 A	5/1998	Toader et al. ....	705/14	5,873,077 A	2/1999	Kanoh et al. ....	707/3
5,751,338 A	5/1998	Ludwig, Jr. ....	348/17	5,873,080 A	2/1999	Coden et al. ....	707/3
5,751,706 A	5/1998	Land et al. ....	370/352	5,878,128 A	3/1999	Kantola .....	379/230
5,751,791 A	5/1998	Chen et al. ....	379/88	5,881,064 A	3/1999	Lin et al. ....	370/395
5,761,281 A	6/1998	Baum et al. ....	379/93.29	5,883,891 A	3/1999	Williams et al. ....	370/356
5,764,644 A	6/1998	Miska et al. ....	370/465	5,884,032 A	3/1999	Bateman et al. ....	395/200.34
5,764,736 A	6/1998	Shachar et al. ....	379/93.09	5,884,262 A	3/1999	Wise et al. ....	704/270
5,764,745 A	6/1998	Chan et al. ....	379/207	5,889,848 A	3/1999	Cookson .....	379/230
5,764,756 A	6/1998	Onweller .....	379/242	5,892,764 A	4/1999	Riemann et al. ....	370/401
5,764,916 A	6/1998	Busey et al. ....	395/200.57	5,892,924 A	4/1999	Lyon et al. ....	395/200.75
5,768,513 A	6/1998	Kuthyar et al. ....	395/200.34	5,905,736 A	5/1999	Ronen et al. ....	370/546
5,768,527 A	6/1998	Zhu et al. ....	395/200.16	5,905,777 A	5/1999	Foladare et al. ....	379/90.01
5,774,660 A	6/1998	Brendel et al. ....	395/200.31	5,905,862 A	5/1999	Hoekstra .....	395/200.32
5,781,620 A	7/1998	Montgomery et al. ....	379/115	5,905,871 A	5/1999	Buskens et al. ....	395/200.75
5,782,642 A	7/1998	Goren .....	434/118	5,905,872 A	5/1999	DeSimone et al. ....	395/200.75
5,784,443 A	7/1998	Chapman et al. ....	379/119	5,907,547 A	5/1999	Foladare et al. ....	370/352
5,784,561 A	7/1998	Bruno et al. ....	395/200.34	5,907,602 A	5/1999	Peel et al. ....	379/114
5,787,150 A	7/1998	Reiman et al. ....	379/67	5,907,607 A	5/1999	Waters et al. ....	379/207
5,787,160 A	7/1998	Chaney et al. ....	379/220	5,915,008 A	6/1999	Dulman .....	379/201
5,787,163 A	7/1998	Taylor et al. ....	379/265	5,923,659 A	7/1999	Curry et al. ....	370/401
5,790,174 A	8/1998	Richard, III et al. ....	348/7	5,931,961 A	8/1999	Ranganathan et al. ....	714/712
5,790,548 A	8/1998	Sistanizadeh et al. ....	370/401	5,940,479 A	8/1999	Guy et al. ....	379/93.01
5,790,645 A	8/1998	Fawcett et al. ....	379/189	5,946,299 A	8/1999	Blonder .....	370/237
5,790,798 A	8/1998	Bekcett, II et al. ....	395/200.54	5,959,996 A	9/1999	Byers .....	370/401
5,793,498 A	8/1998	Scholl et al. ....	358/434	5,970,059 A	10/1999	Ahopelto et al. ....	370/338
5,799,016 A	8/1998	Onweller .....	370/401	5,970,477 A	10/1999	Roden .....	705/32
5,799,017 A	8/1998	Gupta et al. ....	370/419	5,978,842 A	11/1999	Noble et al. ....	709/218
5,799,307 A	8/1998	Buitron .....	707/100	5,991,810 A	11/1999	Shapiro et al. ....	709/229
5,802,283 A	9/1998	Grady et al. ....	395/200.12	5,999,956 A	12/1999	Deville .....	708/322
5,802,510 A	9/1998	Jones .....	707/2	6,003,030 A	12/1999	Kenner et al. ....	707/10
5,802,518 A	9/1998	Karaev et al. ....	707/9	6,009,469 A	12/1999	Mattaway et al. ....	709/227
5,805,587 A	9/1998	Norris et al. ....	370/352	6,011,794 A	1/2000	Mordowitz et al. ....	370/389
5,805,700 A	9/1998	Nardone et al. ....	380/10	6,016,307 A	* 1/2000	Kaplan et al. ....	370/238
5,809,110 A	9/1998	Ulrich et al. ....	379/30	6,020,915 A	2/2000	Bruno et al. ....	348/15
5,809,415 A	9/1998	Rossmann .....	455/422	6,031,904 A	2/2000	An et al. ....	379/201
5,812,278 A	9/1998	Toyoda et al. ....	358/402	6,064,653 A	5/2000	Farris .....	370/237
5,812,640 A	9/1998	Chawla et al. ....	379/89	6,069,890 A	5/2000	White et al. ....	370/352
5,812,654 A	9/1998	Anderson et al. ....	379/270	6,104,720 A	* 8/2000	Kisor .....	370/431

6,154,744	A	11/2000	Kenner et al. ....	707/10
6,175,870	B1	1/2001	Gawlick et al. ....	709/227
6,208,658	B1 *	3/2001	Pickett .....	370/401
6,212,192	B1	4/2001	Mirashrafi et al. ....	370/401
6,288,738	B1	9/2001	Dureau et al. ....	348/6
6,311,180	B1	10/2001	Fogarty .....	707/4
6,335,927	B1	1/2002	Elliott et al. ....	370/352

FOREIGN PATENT DOCUMENTS

EP	0649265	A1	4/1995	.....	H04Q/3/00
EP	0651548	A1	5/1995	.....	H04M/3/22
EP	0668681	A2	8/1995	.....	H04L/12/56
EP	0669736	A2	8/1995	.....	H04L/12/56
EP	0669737	A2	8/1995	.....	H04L/12/56
EP	0674459	A2	9/1995	.....	H04Q/11/04
EP	0687124	A3	12/1995	.....	H04Q/11/04
EP	0373228	B1	2/1996	.....	H04L/12/56
EP	0715443	A2	6/1996	.....	H04M/3/42
EP	0720396	A2	7/1996	.....	H04Q/3/66
EP	0767568	A2	4/1997	.....	H04M/3/42
EP	0781016	A2	6/1997	.....	H04M/1/00
EP	0783217	A2	7/1997	.....	H04L/3/22
EP	0785697	A2	7/1997	.....	H04Q/11/04
EP	0785698	A2	7/1997	.....	H04Q/11/04
EP	0785699	A2	7/1997	.....	H04Q/11/04
EP	0802690	A1	10/1997	.....	H04Q/3/00
EP	0809410	A2	11/1997	.....	H04Q/3/66
EP	0849916	A2	6/1998	.....	H04L/12/56
JP	60-177761		9/1985	.....	
JP	6-172462		6/1997	.....	H04L/12/66
JP	9-168051		6/1997	.....	H04M/11/66
JP	9-168063		6/1997	.....	H04M/11/06
JP	9-168064		6/1997	.....	H04M/11/06
JP	9-168065		6/1997	.....	H04M/11/06
JP	9-172459		6/1997	.....	H04L/12/56
WO	WO 88/07298		9/1988	.....	H04L/11/20
WO	WO 91/07839		5/1991	.....	H04M/11/06
WO	WO 92/13406		8/1992	.....	H04L/3/12
WO	WO 95/11574		4/1995	.....	H04Q/3/00
WO	WO 95/22221		8/1995	.....	H04M/3/30
WO	WO 95/26091		9/1995	.....	H04M/3/42
WO	WO 95/32588		11/1995	.....	H04Q/3/00
WO	WO 95/34972		12/1995	.....	H04L/12/16
WO	WO 96/17457		6/1996	.....	H04L/12/56
WO	WO 96/20553		7/1996	.....	H04M/3/50
WO	WO 96/29805		9/1996	.....	H04L/12/56
WO	WO 96/32800		10/1996	.....	H04M/1/00
WO	WO 96/34341		10/1996	.....	G06F/13/00
WO	WO 96/34479		10/1996	.....	H04L/12/56
WO	WO 96/38018		11/1996	.....	H04Q/11/04
WO	WO 97/07637		2/1997	.....	H04Q/3/00
WO	WO 97/09218		3/1997	.....	B61L/27/00
WO	WO 97/11553		3/1997	.....	H04M/15/00
WO	WO 97/14238		4/1997	.....	H04L/12/46
WO	WO 97/19411		5/1997	.....	G06F/13/42
WO	WO 97/21313		6/1997	.....	H04Q/7/22
WO	WO 97/22211		6/1997	.....	H04Q/3/00
WO	WO 97/23078		6/1997	.....	H04L/12/56
WO	WO 97/28628		8/1997	.....	H04L/12/56
WO	WO 97/32448		9/1997	.....	H04Q/11/04
WO	WO 97/33412		9/1997	.....	H04L/12/56
WO	WO 97/34394		9/1997	.....	H04L/12/56
WO	WO 97/48197		12/1997	.....	
WO	WO 98/04092		1/1998	.....	H04Q/3/66
WO	WO 98/09456		3/1998	.....	H04Q/7/24
WO	WO 98/12860		3/1998	.....	H04M/3/42
WO	WO 98/23080		5/1998	.....	H04M/7/00
WO	WO 98/26530		6/1998	.....	H04J/3/02
WO	WO 98/27754		6/1998	.....	H04Q/3/00

OTHER PUBLICATIONS

*Access the Intelligent Network*, <http://www.gteins/net/overview.htm>, Oct. 30, 1997.

Gerla, Mario and Kleinrock, Leonard, "Flow Control: A Comparative Survey"; IEEE Transactions on Communications, vol. Com-28, No. 4, Apr. 1980, pp. 553-574.

Majithia, J.C., Irland, M., Grange, J.L., Cohen, N., O'Donnell, C.; "Experiments in Congestion Control Techniques", Flow Control in Computer Networks (1979), pp. 211-234.

Turner, Jonathan S., New Directions in Communications (or Which Way to the Information Age?), IEEE Communications Magazine, vol. 24, No. 10, Oct. 1986, pp. 8-15.

American National Standard for Telecommunications, "Integrated Services Digital Network (ISDN)-Signaling Specification for Frame Relay Bearer Service for Digital Subscriber Signaling System No. 1 (DSS1) (Protocol encapsulation and PICS)." Approved Jan. 20, 1994.

American National Standard for Telecommunications, "Integrated Services Digital Network (ISDN)-Architectural Framework and Service Description for Frame-Relaying Bearer Service (Congestion Management and Frame Size)." Approved Apr. 29, 1992, pp. 1-12.

American National Standard for Telecommunications, "Integrated Services Digital Network (ISDN)-Core Aspects of Frame Protocol for Use with Frame Relay Bearer Service." Approved Oct. 24, 1991.

American National Standard for Telecommunications, "Integrated Services Digital Network (ISDN)-Signaling Specification for Frame Relay Bearer Service for Digital Subscriber Signaling System No. 1 (DSS1)." Approved Oct. 24, 1991.

ATM Forum: Technical Committee ATM. "ATM Data Exchange Interface (DXI) Specification." Aug., 1993.

Case, J.D., J.R. Davins, M.S. Fedor, and M.L. Schoffstall, "Introduction to the Simple Gateway Monitoring Protocol." IEEE Network, vol. 2, No. 2, Mar. 1988.

Chapman, John T. and M. Halabi, "High Speed Serial Interface (HSSI) Design Specification." Cisco Systems and T3 Plus Networking, Inc. Revision 3.0, Apr. 12, 1993.

Garcia-Luna-Aceves, J.J., "Loop-Free Routing Using Diffusing Computations." IEEE/ACM Transactions on Networking, vol. 1, No. 1, 1993.

Ross, F.E., "FDDI-A Tutorial." IEEE Communications Magazine, vol. 24, No. 5: May 1986.

Zimmerman, H., "OSI Reference Model-The ISO Model of Architecture for Open Systems Interconnection." IEEE Transactions on Communications COM-28, No. 4: Apr. 1980.

Abstract for 09168033 A, Patent Abstracts of Japan, 1997.

Abstract for 09168051 A, Patent Abstracts of Japan, 1997.

Abstract for 09168063 A, Patent Abstracts of Japan, 1997.

Abstract for 09168064 A, Patent Abstracts of Japan, 1997.

Abstract for 09168065 A, Patent Abstracts of Japan, 1997.

Abstract for 09172459 A, Patent Abstracts of Japan, 1997.

Abstract for 09172462 A, Patent Abstracts of Japan, 1997.

Aidarous et al., "The Role of the Element Management Layer in Network Management", 1994 IEEE Network Operations and Management Symposium, Feb. 1994, pp. 59-69.

Bethoney, Herb "HAHTSite Gives Pros Everything They Need." PC World, Mar. 1997, pp. 26-27.

- Bohn, Roger et al., "Mitigating the Coming Internet Crunch: Multiple Service Levels via Precedence", *Journal of High Speed Network*, vol. 3, No. 4, 1994, pp. 335-349.
- Braun, Torsten et al., "Implementation of an Internet Video Conferencing Application Over ATM", 1997 IEEE, pp. 287-294.
- Chen, Larry et al., "ATM and Satellite Distribution of Multimedia Educational Courseware", 1995 IEEE International Conference on Communications, Jun. 1995, pp. 1133-1137.
- Civanlar, M. Reha et al., "FusionNet: Joining the Internet & Phone Networks for Multimedia Applications", *ACM Multimedia 96*, pp. 431-432.
- Cobbold, Christopher et al., "Enhancement for Integrated Wireless Personal Communications Over Metropolitan Area Networks", 1996 IEEE International Conference on Communications, Jun. 1996, pp. 1370-1376.
- Comer, Douglas, "Internetworking with TCP/IP vol. I: Principles, Protocols, and Architecture", Third Ed., Prentice Hall, 1995, pp. 143-153.
- Diehl, Stanford, "Data's New Voice", *BYTE*, Sep. 1996, pp. 129-135.
- Duan, Juan et al., "Efficient Utilization of Multiple Channels Between Two Switches in ATM Networks", Department of Computer Science—University of South Carolina, Feb. 1995, pp. 1906-1911.
- Ejiri, Masayoshi, "For Whom the Advancing Service/Network Management", 1996 IEEE International Conference on Communications, Jun. 1996, pp. 422-433.
- Elia, Carlo et al., "Skylex: Distribution Up-Link for Digital Television Via Satellite", Dec. 1996, pp. 305-313.
- Ely, Tom, "The Service Control Point as a Cross Network Integrator", IEEE Intelligent Network Workshop in 96, Apr. 1996, pp. 1-8.
- Eriksson, Hans, "MBONE: The Multicast Backbone", *Communications of the ACM*, vol. 57, No. 8, Aug. 1994, pp. 54-60.
- Feinmann, "VIC Computer Telephony", *Computer Telephony*, Mar. 1996, pp. 219-221.
- Fridisch, M. et al., "Terminals for Accessing the Internet—The Internet Telephone", *Alcatel Telecommunications Review—4<sup>th</sup> Quarter 1996*, pp. 304-309.
- Ganor, Elon, "Talk Talk", *Tele.com*, Jun. 1996, pp. 68-72.
- Gareiss, Robin, "Voice Over the Internet", *Data Communications*, vol. 25, No. 12, Sep. 1996, pp. 93, 94, 96, 98, 100.
- Gralla, Preston, "How the Internet Works", 1996 by Macmillan Computer Publishing USA; Part 3 Communicating on the Internet, Chapter 12 "Making Phone Calls on the Internet", pp. 64-67; Part 5 Multimedia on the Internet, Chapter 19 "Video on the Internet", pp. 104-111.
- Gralla, Preston, Part 4 Communicating on the Internet, "How to Make Phone Calls Using Your PC and the Internet", pp. 118-119.
- Grami et al., "The Role of Satellites in the Information Superhighway", 1994 IEEE Network Operations and Management Symposium, Feb. 1994, pp. 1577-1581.
- Gupta et al., "Technical Assessment of (T) INA-TMN-OSI Technology for Service Management Applications", IEEE Intelligent Network Workshop, Apr. 1996, pp. 877-887.
- Gys, L. et al., "Intelligence in the Network", *Alcatel Telecommunications Review—1<sup>st</sup> Quarter 1998*, pp. 13-22.
- Hurwicz, Michael, "Faster Smarter Nets", Apr. 1997, pp. 100-101.
- Inamori et al., "Applying TMN to a Distributed Communications Node System with Common Platform Software", Feb. 1995, pp. 83-87.
- Jain, Surinder, "Evolving Existing Narrowband Networks Broadband Networks with IN Capabilities", Apr. 22, 1996.
- Kahn, Jeffery, "Videoconferencing Debuts on the Internet", Feb. 28, 1995.
- Kelly, Katy, "Mountaintop Office Keeps Skiers in Touch", *USA Today*, vol. 15, No. 112.
- Kim, Gary, "Talk is Cheap", *America's Network*, Jul. 15, 1996, pp. 34-39.
- Kishimoto, Ryoza, "Agent Communication System for Multimedia Communication Services", 1995 IEEE International Conference on Communications, pp. 10-17.
- Kolarov et al., "End-to-End Adaptive Rate Based Congestion Control Scheme for ABR Service in Wide Area ATM Networks", IEEE INFOCOM, Mar. 1996, pp. 138-143.
- Kumar, Vinay, "Internet Multicasting: Internet's Next Big Thing", ICAST Corp. 1997.
- Lapolla, Stephanie, *PC Week*, "Net Call Centers, Voice to Merge", Mar. 31, 1997, p. 10.
- Li, Chung-Sheng et al., "Time-Driven Priority Flow Control for Real-Time Heterogeneous Internetworking", Proceedings in Computer Communications, Fifteenth Annual Joint Conference of the IEEE Computer and Communication Generation, San Francisco, Mar. 24-28, 1996, vol. 1, Conf., Mar. 24, 1996, IEEE, pp. 189-197.
- Louth, Nick, Reuters, "MCI Communications Corp Vaults Phone-Data Divide", MCI Communications Corp. New Page, Jan. 29, 1997, web page attached.
- Low, Colin, et al., "WebIN—An Architecture for Fast Development of IN-Based Personal Services", Workshop Record Intelligent Network. Freedom and Flexibility: Realizing the Promise of Intelligent Network Services, Apr. 21, 1996, pp. 1-12.
- Macedonia, Michael et al., "MBone Provides Audio and Video Across the Internet", Apr. 1994, pp. 30-36.
- Margulies, Ed, "CT" Cyberdate with the Net", *Computer Telephony Periscope*, Aug. 1996, pp. 28-29.
- Matta, I., et al., Type-of-Service Routing in Dynamic Datagram Networks, Proceedings of the Conference on Computer Communications IEEE, Issue 3, 1994, pp. 992-999.
- Miller, Mark, "Troubleshooting TCP/IP", *Managing the Internet*, Chapter 7, 1992, pp. 365-389.
- Newton, Harry, "The Personal Side of CT", *Computer Telephony*, Jan. 1997.
- Oppen, et al.: "The Clearinghouse: A Decentralized Agent for Locating Named Objects in a Distributed Environment" *ACM Transactions on Office Information Systems*, vol. 1, No. 3, Jul. 1983, pp. 230-253.
- Peeren, Rene, "The Intelligent Web", IEEE Intelligent Network Workshop, Apr. 1996, vol. 1.
- Perret et al., "MAP: Mobile Assistant Programming for Large Scale Communications Networks", 1995 IEEE International Conference on Communications, Jun. 1995, pp. 1128-1132.
- Pezzutti, David, "Operations Issued for Advanced Intelligent Networks", *IEEE Communications Magazine*, Feb. 1992, pp. 58-63.
- Platt, Richard, "Why IsoEthernet Will Change the Voice and Video Worlds", *IEEE Communications Magazine*, Apr. 1996, pp. 55-58.

# Explore Litigation Insights

Docket Alarm provides insights to develop a more informed litigation strategy and the peace of mind of knowing you're on top of things.

## Real-Time Litigation Alerts



Keep your litigation team up-to-date with **real-time alerts** and advanced team management tools built for the enterprise, all while greatly reducing PACER spend.

Our comprehensive service means we can handle Federal, State, and Administrative courts across the country.

## Advanced Docket Research



With over 230 million records, Docket Alarm's cloud-native docket research platform finds what other services can't. Coverage includes Federal, State, plus PTAB, TTAB, ITC and NLRB decisions, all in one place.

Identify arguments that have been successful in the past with full text, pinpoint searching. Link to case law cited within any court document via Fastcase.

## Analytics At Your Fingertips



Learn what happened the last time a particular judge, opposing counsel or company faced cases similar to yours.

Advanced out-of-the-box PTAB and TTAB analytics are always at your fingertips.

## API

Docket Alarm offers a powerful API (application programming interface) to developers that want to integrate case filings into their apps.

## LAW FIRMS

Build custom dashboards for your attorneys and clients with live data direct from the court.

Automate many repetitive legal tasks like conflict checks, document management, and marketing.

## FINANCIAL INSTITUTIONS

Litigation and bankruptcy checks for companies and debtors.

## E-DISCOVERY AND LEGAL VENDORS

Sync your system to PACER to automate legal marketing.