



UNITED STATES PATENT AND TRADEMARK OFFICE

UNITED STATES DEPARTMENT OF COMMERCE
United States Patent and Trademark Office
Address: COMMISSIONER FOR PATENTS
P. O. Box 1450
Alexandria, Virginia 22313-1450
www.uspto.gov

Table with 5 columns: APPLICATION NO., ISSUE DATE, PATENT NO., ATTORNEY DOCKET NO., CONFIRMATION NO.
Row 1: 15/717,138, 03/13/2018, 9918196, TX1000-C7, 3036

59911 7590 02/21/2018
MITCH HARRIS, LLC - GENERAL
P.O. BOX 1269
ATHENS, GA 30603-1269

ISSUE NOTIFICATION

The projected patent number and issue date are specified above.

Determination of Patent Term Adjustment under 35 U.S.C. 154 (b)
(application filed on or after May 29, 2000)

The Patent Term Adjustment is 0 day(s). Any patent to issue from the above-identified application will include an indication of the adjustment on the front page.

If a Continued Prosecution Application (CPA) was filed in the above-identified application, the filing date that determines Patent Term Adjustment is the filing date of the most recent CPA.

Applicant will be able to obtain more detailed information by accessing the Patent Application Information Retrieval (PAIR) WEB site (http://pair.uspto.gov).

Any questions regarding the Patent Term Extension or Adjustment determination should be directed to the Office of Patent Legal Administration at (571)-272-7702. Questions relating to issue and publication fee payments should be directed to the Application Assistance Unit (AAU) of the Office of Data Management (ODM) at (571)-272-4200.

APPLICANT(s) (Please see PAIR WEB site http://pair.uspto.gov for additional applicants):

Traxcell Technologies, LLC, Plano, TX;
Mark Jefferson Reed, Tucson, AZ;
Stephen Michael Palik, Redondo Beach, CA;

The United States represents the largest, most dynamic marketplace in the world and is an unparalleled location for business investment, innovation, and commercialization of new technologies. The USA offers tremendous resources and advantages for those who invest and manufacture goods here. Through SelectUSA, our nation works to encourage and facilitate business investment. To learn more about why the USA is the best country in the world to develop technology, manufacture products, and grow your business, visit SelectUSA.gov.

actual field testing. Problems recorded in the field could be resolved without delay. The WNTS functions in a basic sense by monitoring the wireless network for problems that affect service to connected wireless devices. When these problems are detected the WNTS can then monitor and track all wireless devices in the problem area and record data on faults and problems these wireless device incur relevant to their latitude/longitude. The WNTS can then correct the problem automatically, or make suggestions to the wireless network engineers for the possible cause of the problem and corrective actions, which may fix the problem.

**[0243]** The most common method to debug these problems is for engineers to go to the field and take limited "snaps shots" of the wireless network that only record data for brief periods of time on limited wireless devices. The process and machine as claimed within, allows a plurality of wireless devices to be monitored and recorded over a period of time, as well as wireless network parameters as they interact with the wireless devices, and additionally record faults these wireless devices incur at specific geographic locations.

**[0244]** To be able to employ the embodiments of this method, process, and machine, you must have the ability to find and locate wireless devices on the wireless network. Also, an additional technology that would allow rapid access to this data would be a dynamic database or system designed to store and hold information including latitude and longitude of the said wireless devices. The ability to determine the user's geographic location in the form of latitude and longitude data is disclosed in an attached document entitled, "A machine for providing a dynamic database of geographic location information for a plurality of wireless communications devices and process for making same". This document referenced above, is a United States Provisional Patent, U.S. Serial Number 60/327,327, which was filed on ~~October 0, 2001~~ <sup>October 4, 2001</sup>. This provisional patent application references the use of user location databases (ULD), user location database coordinators (ULDC), and other location means The use of ULD, ULDC, and other location means is disclosed (offered only as an example of location means) in the fore mentioned provisional patent application, but can also include other means of location including a wireless device comprising a global positioning system (GPS).

Change(s) applied  
to document,  
/M.I.G./  
12/26/2017

**[0245]** The fore mentioned provisional patent provides a system that allows a plurality of

**PART B - FEE(S) TRANSMITTAL**

**Complete and send this form, together with applicable fee(s), to: Mail Mail Stop ISSUE FEE  
 Commissioner for Patents  
 P.O. Box 1450  
 Alexandria, Virginia 22313-1450  
 or Fax (571)-273-2885**

**INSTRUCTIONS:** This form should be used for transmitting the ISSUE FEE and PUBLICATION FEE (if required). Blocks 1 through 5 should be completed where appropriate. All further correspondence including the Patent, advance orders and notification of maintenance fees will be mailed to the current correspondence address as indicated unless corrected below or directed otherwise in Block 1, by (a) specifying a new correspondence address; and/or (b) indicating a separate "FEE ADDRESS" for maintenance fee notifications.

CURRENT CORRESPONDENCE ADDRESS (Note: Use Block 1 for any change of address)

59911 7590 12/13/2017  
**MITCH HARRIS, LLC - GENERAL**  
 P.O. BOX 1269  
 ATHENS, GA 30603-1269

Note: A certificate of mailing can only be used for domestic mailings of the Fee(s) Transmittal. This certificate cannot be used for any other accompanying papers. Each additional paper, such as an assignment or formal drawing, must have its own certificate of mailing or transmission.

**Certificate of Mailing or Transmission**  
 I hereby certify that this Fee(s) Transmittal is being deposited with the United States Postal Service with sufficient postage for first class mail in an envelope addressed to the Mail Stop ISSUE FEE address above, or being facsimile transmitted to the USPTO (571) 273-2885, on the date indicated below.

(Depositor's name)
(Signature)
(Date)

APPLICATION NO.	FILING DATE	FIRST NAMED INVENTOR	ATTORNEY DOCKET NO.	CONFIRMATION NO.
15/717,138	09/27/2017	Mark Jefferson Reed	TX1000-C7	3036

TITLE OF INVENTION: INTERNET QUERIED DIRECTIONAL NAVIGATION SYSTEM WITH MOBILE AND FIXED ORIGINATING LOCATION DETERMINATION

APPLN. TYPE	ENTITY STATUS	ISSUE FEE DUE	PUBLICATION FEE DUE	PREV. PAID ISSUE FEE	TOTAL FEE(S) DUE	DATE DUE
nonprovisional	SMALL	\$480	\$0	\$0	\$480	03/13/2018

EXAMINER	ART UNIT	CLASS-SUBCLASS
PATEL, AJIT	2644	455-456300

<p>1. Change of correspondence address or indication of "Fee Address" (37 CFR 1.363).</p> <p><input type="checkbox"/> Change of correspondence address (or Change of Correspondence Address form PTO/SB/122) attached.</p> <p><input type="checkbox"/> "Fee Address" indication (or "Fee Address" Indication form PTO/SB/47; Rev 03-02 or more recent) attached. Use of a Customer Number is required.</p>	<p>2. For printing on the patent front page, list</p> <p>(1) The names of up to 3 registered patent attorneys or agents OR, alternatively,</p> <p>(2) The name of a single firm (having as a member a registered attorney or agent) and the names of up to 2 registered patent attorneys or agents. If no name is listed, no name will be printed.</p> <p>1 <u>Mitch Harris, Atty at Law, LLC</u></p> <p>2 <u>Andrew M. Harris</u></p> <p>3 _____</p>
--	---

3. ASSIGNEE NAME AND RESIDENCE DATA TO BE PRINTED ON THE PATENT (print or type)

PLEASE NOTE: Unless an assignee is identified below, no assignee data will appear on the patent. If an assignee is identified below, the document has been filed for recordation as set forth in 37 CFR 3.11. Completion of this form is NOT a substitute for filing an assignment.

(A) NAME OF ASSIGNEE TRAXCELL TECHNOLOGIES LLC

(B) RESIDENCE: (CITY and STATE OR COUNTRY) PLANO, TX

Please check the appropriate assignee category or categories (will not be printed on the patent):  Individual  Corporation or other private group entity  Government

<p>4a. The following fee(s) are submitted:</p> <p><input checked="" type="checkbox"/> Issue Fee</p> <p><input type="checkbox"/> Publication Fee (No small entity discount permitted)</p> <p><input type="checkbox"/> Advance Order - # of Copies _____</p>	<p>4b. Payment of Fee(s): (Please first reapply any previously paid issue fee shown above)</p> <p><input type="checkbox"/> A check is enclosed.</p> <p><input type="checkbox"/> Payment by credit card. Form PTO-2038 is attached.</p> <p><input type="checkbox"/> The director is hereby authorized to charge the required fee(s), any deficiency, or credits any overpayment, to Deposit Account Number _____ (enclose an extra copy of this form).</p>
--	---

5. Change in Entity Status (from status indicated above)

Applicant certifying micro entity status. See 37 CFR 1.29

Applicant asserting small entity status. See 37 CFR 1.27

Applicant changing to regular undiscounted fee status.

NOTE: Absent a valid certification of Micro Entity Status (see forms PTO/SB/15A and 15B), issue fee payment in the micro entity amount will not be accepted at the risk of application abandonment.

NOTE: If the application was previously under micro entity status, checking this box will be taken to be a notification of loss of entitlement to micro entity status.

NOTE: Checking this box will be taken to be a notification of loss of entitlement to small or micro entity status, as applicable.

NOTE: This form must be signed in accordance with 37 CFR 1.31 and 1.33. See 37 CFR 1.4 for signature requirements and certifications.

Authorized Signature /Andrew Mitchell Harris #42,638/ Date 01-26-2018

Typed or printed name Andrew M. Harris Registration No. 42,638



UNITED STATES PATENT AND TRADEMARK OFFICE

UNITED STATES DEPARTMENT OF COMMERCE  
United States Patent and Trademark Office  
Address: COMMISSIONER FOR PATENTS  
P. O. Box 1450  
Alexandria, Virginia 22313-1450  
www.uspto.gov

APPLICATION NO.	FILING DATE	FIRST NAMED INVENTOR	ATTORNEY DOCKET NO.	CONFIRMATION NO.
15/717,138	09/27/2017	Mark Jefferson Reed	TX1000-C7	3036
59911 7590 01/09/2018 MITCH HARRIS, LLC - GENERAL P.O. BOX 1269 ATHENS, GA 30603-1269			EXAMINER	
			PATEL, AJIT	
			ART UNIT	PAPER NUMBER
			2644	
			MAIL DATE	DELIVERY MODE
			01/09/2018	PAPER

**Please find below and/or attached an Office communication concerning this application or proceeding.**

The time period for reply, if any, is set in the attached communication.



<b>Corrected Notice of Allowability</b>	<b>Application No.</b> 15/717,138	<b>Applicant(s)</b> REED ET AL.	
	<b>Examiner</b> AJIT PATEL	<b>Art Unit</b> 2644	<b>AIA (First Inventor to File) Status</b> No

**-- The MAILING DATE of this communication appears on the cover sheet with the correspondence address--**

All claims being allowable, PROSECUTION ON THE MERITS IS (OR REMAINS) CLOSED in this application. If not included herewith (or previously mailed), a Notice of Allowance (PTOL-85) or other appropriate communication will be mailed in due course. **THIS NOTICE OF ALLOWABILITY IS NOT A GRANT OF PATENT RIGHTS.** This application is subject to withdrawal from issue at the initiative of the Office or upon petition by the applicant. See 37 CFR 1.313 and MPEP 1308.

1.  This communication is responsive to IDS filed on 12/27/17.  
 A declaration(s)/affidavit(s) under 37 CFR 1.130(b) was/were filed on \_\_\_\_\_.
2.  An election was made by the applicant in response to a restriction requirement set forth during the interview on \_\_\_\_\_; the restriction requirement and election have been incorporated into this action.
3.  The allowed claim(s) is/are 1-30. As a result of the allowed claim(s), you may be eligible to benefit from the **Patent Prosecution Highway** program at a participating intellectual property office for the corresponding application. For more information, please see [http://www.uspto.gov/patents/init\\_events/pph/index.jsp](http://www.uspto.gov/patents/init_events/pph/index.jsp) or send an inquiry to PPHfeedback@uspto.gov.
4.  Acknowledgment is made of a claim for foreign priority under 35 U.S.C. § 119(a)-(d) or (f).

**Certified copies:**

- a)  All    b)  Some    \*c)  None of the:
1.  Certified copies of the priority documents have been received.
  2.  Certified copies of the priority documents have been received in Application No. \_\_\_\_\_.
  3.  Copies of the certified copies of the priority documents have been received in this national stage application from the International Bureau (PCT Rule 17.2(a)).

\* Certified copies not received: \_\_\_\_\_.

Applicant has THREE MONTHS FROM THE "MAILING DATE" of this communication to file a reply complying with the requirements noted below. Failure to timely comply will result in ABANDONMENT of this application.  
**THIS THREE-MONTH PERIOD IS NOT EXTENDABLE.**

5.  CORRECTED DRAWINGS ( as "replacement sheets") must be submitted.  
 including changes required by the attached Examiner's Amendment / Comment or in the Office action of Paper No./Mail Date \_\_\_\_\_.  
**Identifying indicia such as the application number (see 37 CFR 1.84(c)) should be written on the drawings in the front (not the back) of each sheet. Replacement sheet(s) should be labeled as such in the header according to 37 CFR 1.121(d).**
6.  DEPOSIT OF and/or INFORMATION about the deposit of BIOLOGICAL MATERIAL must be submitted. Note the attached Examiner's comment regarding REQUIREMENT FOR THE DEPOSIT OF BIOLOGICAL MATERIAL.

**Attachment(s)**

- |  |   |
|--|---|
| <ol style="list-style-type: none"> <li>1. <input type="checkbox"/> Notice of References Cited (PTO-892)</li> <li>2. <input checked="" type="checkbox"/> Information Disclosure Statements (PTO/SB/08),<br/>Paper No./Mail Date _____</li> <li>3. <input type="checkbox"/> Examiner's Comment Regarding Requirement for Deposit of Biological Material</li> <li>4. <input type="checkbox"/> Interview Summary (PTO-413),<br/>Paper No./Mail Date _____</li> </ol> | <ol style="list-style-type: none"> <li>5. <input type="checkbox"/> Examiner's Amendment/Comment</li> <li>6. <input type="checkbox"/> Examiner's Statement of Reasons for Allowance</li> <li>7. <input type="checkbox"/> Other _____.</li> </ol> |
|--|---|

/AJIT PATEL/  
Primary Examiner, Art Unit 2644

Under the Paperwork Reduction Act of 1995, no persons are required to respond to a collection of information unless it displays a valid OMB control number.

Substitute for form 1449/PTO  <b>INFORMATION DISCLOSURE STATEMENT BY APPLICANT</b>	<b>Complete if Known</b>
	Application Number <b>15/717,138</b>
	Filing Date            09/27/2017
	First Named Inventor    Reed
	Examiner Name          PATEL, AJIT
	Art Unit                 2644
	Attorney Docket No.    TX1000-C7

Examiner Initials	Document Number	Publication Date MM-DD-YYYY	Name of Patentee or Applicant of Cited Document	Pages, Columns, Lines, Where Relevant Passages or Relevant Figures Appear
	US 6,662,014-B1	12-09-2003	Walsh	
	US 5,023,900	06-11-1991	Tayloe, et al.	
	US 7,203,752-B2	04-10-2007	Rice, et al.	
	US 20020173318-A1	11-21-2002	Dyer	
	US 5,812,636	09-22-1998	Tseng, et al.	
	US 6,223,032-B1	04-24-2001	Cuffaro	
	US 6,266,013-B1	07-24-2001	Stilp, et al.	
	US 6,138,003	10-24-2000	Kingdon, et al.	
	US 6,757,543-B2	06-29-2004	Moran, et al.	
	US 6,904,013-B2	06-07-2005	Skoog, et al.	
	US 6,430,397-B1	08-06-2002	Willrett	
	US 20010049263-A1	12-06-2001	Zhang	
	US-6,360,102-B1	03-19-2002	Havinis, et al.	
	US-6,442,391-B1	08-27-2002	Johansson, et al.	
	US-6,505,048-B1	01-07-2003	Moles, et al.	
	US-7,085,555-B2	08-01-2006	Zellner, et al.	
	US-6,678,516-B2	01-13-2004	Nordman, et al.	
	US-5,471,649	11-28-1995	Rees, et al.	
	US-5,857,155	01-05-1999	Hill, et al.	
	US-5,425,076	06-13-1995	Knippelmier	
	US-6,445,917-B1	09-03-2002	Bark, et al.	
	US-6,859,463-B1	02-22-2005	Mayor, et al.	
	US-6,188,883-B1	02-13-2001	Takemura	
	US-6,128,507	10-03-2000	Takai	
	US-5,875,398	02-23-1999	Snapp	
	US-6,285,688-B1	09-04-2001	Henderson, et al.	
	US-6,839,560-B1	01-04-2005	Bahl, et al.	
	US-6,353,902-B1	03-05-2002	Kulatunge, et al.	
	US-6,453,152-B1	09-17-2002	Hong, et al.	
	US-5,245,610	09-14-1993	Lindell	

Examiner:            /AJIT    PATEL/

Date Considered:    01/05/2018

EXAMINER: Initial if reference considered, whether or not citation is in conformance with MPEP 609; Draw line through citation if not in conformance and not considered. Include copy of this form with next communication to applicant.

ALL REFERENCES CONSIDERED EXCEPT WHERE LINED THROUGH. /A.P/

Under the Paperwork Reduction Act of 1995, no persons are required to respond to a collection of information unless it displays a valid OMB control number

Substitute for form 1449/PTO  <b>INFORMATION DISCLOSURE                  STATEMENT BY APPLICANT</b>	<b>Complete if Known</b>	
	Application Number	15/717,138
	Filing Date	09/27/2017
	First Named Inventor	Reed
	Examiner Name	PATEL, AJIT
	Art Unit	2644
Attorney Docket No.	TX1000-C7	

Examiner Initials	Document Number	Publication Date MM-DD-YYYY	Name of Patentee or Applicant of Cited Document	Pages, Columns, Lines, Where Relevant Passages or Relevant Figures Appear
	US-5,694,451	12-02-1997	Arinell	
	US-6,226,589-B1	05-01-2001	Maeda, et al.	
	US-6,687,504-B1	02-03-2004	Raith	
	US-6,317,596-B1	11-13-2001	Elwin	
	US-5,570,373	10-29-1996	Wing	
	US-5,790,940	08-04-1998	Laborde, et al.	
	US-5,757,810	05-26-1998	Fall	
	US-5,884,163	03-16-1999	Hardouin	
	US-5,802,473	09-01-1998	Rutledge, et al.	
	US-6,445,916-B1	09-03-2002	Rahman	
	US-6,154,638	11-28-2000	Cheng, et al.	
	US-7,093,286-B1	08-15-2006	King	
	US-6,442,393-B1	08-27-2002	Hogan	
	US-5,603,093	02-11-1997	Yoshimi, et al.	
	US-5,706,333	01-06-1998	Grenning, et al.	
	US-6,640,101-B1	10-28-2003	Daniel	
	US-6,144,861	11-07-2000	Sundelin, et al.	
	US-20020072358-A1	06-13-2002	Schneider, et al.	
	US-6,487,394-B1	11-26-2002	Ue, et al.	
	US-6,847,916-B1	01-25-2005	Ying	
	US-5,933,776	08-03-1999	Kirkpatrick	
	US-6,560,461-B1	05-06-2003	Fomukong, et al.	
	US-6,072,778	06-06-2000	Labeledz, et al.	
	US-6,061,561	05-09-2000	Alanara, et al.	
	US-5,819,177	10-06-1998	Vucetic, et al.	
	US-6,775,544-B2	08-10-2004	Ficarra	
	US-6,594,483-B2	07-15-2003	Nykanen, et al.	
	US-8,199,696-B2	06-12-2012	Sarkar, et al.	
	US-7,072,648-B2	07-04-2006	Ichikawa	
	US-6,070,083	05-30-2000	Watters, et al.	

Examiner: /AJIT PATEL/

Date Considered: 01/05/2018

EXAMINER: Initial if reference considered, whether or not citation is in conformance with MPEP 609; Draw line through citation if not in conformance and not considered. Include copy of this form with next communication to applicant.

ALL REFERENCES CONSIDERED EXCEPT WHERE LINED THROUGH. /A.P/

Under the Paperwork Reduction Act of 1995, no persons are required to respond to a collection of information unless it displays a valid OMB control number

Substitute for form 1449/PTO  <b>INFORMATION DISCLOSURE STATEMENT BY APPLICANT</b>	<b>Complete if Known</b>	
	Application Number	15/717,138
	Filing Date	09/27/2017
	First Named Inventor	Reed
	Examiner Name	PATEL, AJIT
	Art Unit	2644
Attorney Docket No.	TX1000-C7	

Examiner Initials	Document Number	Publication Date MM-DD-YYYY	Name of Patentee or Applicant of Cited Document	Pages, Columns, Lines, Where Relevant Passages or Relevant Figures Appear
	US-6,636,744-B1	10-21-2003	Da	
	US-4,912,705	03-27-1990	Paneth, et al.	
	US-5,526,357	06-11-1996	Jandrell	
	US-5,548,583	08-20-1996	Bustamante	
	US-20020198985-A1	12-26-2002	Fraenkel, et al.	
	US-20030091017-A1	05-15-2003	Davenport, et al.	
	US-20050282540-A1	12-22-2005	Motamedi, et al.	

FOREIGN PATENT DOCUMENTS				
Examiner Initial	Foreign Patent Document	Publication Date MM-DD-YYYY	Name of Patentee or Applicant of Cited Document	Pages, Columns, Lines, Where Relevant Passages or Relevant Figures Appear
	WO 1999012228 A2	03-11-1999	Ameritec Corp.	
	EP 1 071 295 A2	01-24-2001	Phone.Com Inc.	
	JPH07-250381 A	09-26-1995	Fujitsu Ltd.	
	JP 2000-091982	03-31-2000	NEC Corp.	
	JPH11-027729 A	01-29-1999	Sanyo Electric Co.	
	WO 2000010296 A2	02-24-2000	SC-Wireless, Inc.	
	EP 1 126 376 A1	08-22-2001	NTT DoCoMo, Inc.	
	WO 2001076093 A1	10-11-2001	True-Position, Inc.	
	WO 1990004293 A1	04-19-1990	Motorola, Inc.	
	GB 2 252 475 A	08-05-1992	Motorola, Inc.	
	WO 2000028756 A1	05-18-2000	Telefonaktiebolaget L M Ericsson	
	GB 2 357 010 A	06-06-2001	Telefonaktiebolaget L M Ericsson	
	EP 0 714 589 B1	05-06-2004	Borkowski, et al.	
	EP 1 028 543 A1	08-16-2000	Lucent Technologies Inc.	
	WO 1995012268 A1	05-04-1995	Bellsouth Corporation	
	WO 2001046710 A2	06-28-2001	Grid Data, Inc.	
	WO 2000040992 A1	07-13-2000	Trueposition, Inc.	
	WO 2000041402 A2	07-13-2000	Trueposition, Inc.	
	WO 2000077949 A1	12-21-2000	Time Domain Corporation	

Examiner: /AJIT PATEL/

Date Considered: 01/05/2018

EXAMINER: Initial if reference considered, whether or not citation is in conformance with MPEP 609; Draw line through citation if not in conformance and not considered. Include copy of this form with next communication to applicant.

ALL REFERENCES CONSIDERED EXCEPT WHERE LINED THROUGH. /A.P/

Under the Paperwork Reduction Act of 1995, no persons are required to respond to a collection of information unless it displays a valid OMB control number

Substitute for form 1449/PTO  <b>INFORMATION DISCLOSURE                  STATEMENT BY APPLICANT</b>	<b>Complete if Known</b>	
	Application Number	15/717,138
	Filing Date	09/27/2017
	First Named Inventor	Reed
	Examiner Name	PATEL, AJIT
	Art Unit	2644
Attorney Docket No.	TX1000-C7	

NON PATENT LITERATURE	
Examiner Initial	Include name of author (in CAPITAL LETTERS), title of the article (when appropriate), title of the item (book, magazine, journal, serial, symposium, catalog, etc.), date, page(s), volume-issue number(s), publisher, city and/or country where published.
	VUCETIC, et al. "Signal Monitoring System for Wireless Network Operation and Management", Dynamic Telecommunications, Inc., 0-7803-5030-8/98, 1998, pp. 296-300, IEEE
	3rd Generation Partnership Project: Technical Specification Group Radio Access Network: RRC Protocol Specification, 3GPP TS 25.331, V3.6.0 (2001-03), Release 1999, 2001, pp. 1-708, France
	3rd Generation Partnership Project: Technical Specification Group Services and System Aspects: Functional Stage 2 Description of LCS (Release 4), 3G TS 23.271, v 2.0.0 (2000-12) 2000, pps. 1-57, FR
	BENNINGTON, et al. "Wireless Andrew: Experience Building a High Speed, Campus-Wide Wireless Data Network," MOBICOM 97, ACM 0-89791-988-2/97/9, 1997, pp. 55-65, Budapest, Hungary
	ANHALT, et al., "Toward Context Aware Computing: Experiences and Lessons," IEEE Intelligent Systems, 1094-7167/01, May/June 2001, pp. 38-46. IEEE.
	ECKHARDT, et al. "Measurement and Analysis of the Error Characteristics of an In-Building Wireless Network", Proceedings of SIGCOMM '96, Aug. 1996, pp. 1-12 (12 pages in pdf), Stanford, CA.
	HE, et al., "WaveGuard: Secure Location Service for Wireless Andrew," Wireless 2001, 13 <sup>th</sup> International Conference on Wireless Communications, Proceedings vol. 1, 9-11 July 2001, pp. 252-259, CA.
	HILLS, "Large-Scale Wireless LAN Design," IEEE Communications Magazine, 0163-6804/01, Nov 2001, pp. 98-104, IEEE.
	HILLS, "Bringing Mobile Computing to a University Community of 10,000," IEEE Spectrum, 0018-9235/99, June 1999, pp. 49-53, IEEE.
	HILLS, et al, "Seamless access to multiple wireless data networks; A Wireless Data Network Infrastructure at Carnegie Mellon University," IEEE Personal Communications, vol. 3, no. 1, 1070-9916/96, February 1996, pp. 56-63, IEEE
	JOHNSON, et al., "Truly seamless wireless and mobile host networking; Protocols for Adaptive Wireless and Mobile Networking," IEEE Personal Communications, 1070-9916/96, February 1996, pp. 34-42, IEEE.
	SMALL, et al., "Determining User Location for Context Aware Computing Through the Use of a Wireless LAN Infrastructure", 2000, 8 pages (pp. 1-8 in pdf), Institute for Complex Engineered Systems, Carnegie Mellon University, Pittsburgh, PA.
	HASSAN, "Cellular Optimization", Cellular Business, September 1995, pp. 122-126
	MILETIC, "Looking for Trouble", Wireless Review, 15 January 2001, pp. 52-54.
	BISDIKIAN, et al., "Enabling Location-Based Applications", WMC 01, ACM 2001 1-58113-376-6/01/07, 2001, pp. 38-42, Rome, Italy.
	ATENIESE, et al. "Untraceable Mobility or How to Travel Incognito", Computer Networks 31, 1389-1286/99, 1999, pp. 871-884, Elsevier Science B.V.
	LEE, et al., "Enhanced privacy and authentication for the global system for mobile communications", Wireless Networks 5, 1999, pp. 231-243, Science Publishers, J.C. Baltzer.
	BERA, et al., "Performance Analysis of Dynamic Location Updation Strategies for Mobile Users", Proc. Of 2000 International Conference on Distributed Computing Systems, April 2000, 8 pages (pp. 1-8 in pdf), Taiwan.

Examiner:           /AJIT PATEL/           Date Considered:           01/05/2018          

EXAMINER: Initial if reference considered, whether or not citation is in conformance with MPEP 609; Draw line through citation if not in conformance and not considered. Include copy of this form with next communication to applicant.

ALL REFERENCES CONSIDERED EXCEPT WHERE LINED THROUGH. /A.P/

Under the Paperwork Reduction Act of 1995, no persons are required to respond to a collection of information unless it displays a valid OMB control number

Substitute for form 1449/PTO  <b>INFORMATION DISCLOSURE STATEMENT BY APPLICANT</b>	<b>Complete if Known</b>	
	Application Number	15/717,138
	Filing Date	09/27/2017
	First Named Inventor	Reed
	Examiner Name	PATEL, AJIT
	Art Unit	2644
	Attorney Docket No.	TX1000-C7

NON PATENT LITERATURE	
Examiner Initial	Include name of author (in CAPITAL LETTERS), title of the article (when appropriate), title of the item (book, magazine, journal, serial, symposium, catalog, etc.), date, page(s), volume-issue number(s), publisher, city and/or country where published.
	HEPSAYDIR, "Mobile Positioning in CDMA Cellular Networks", 38 <sup>th</sup> IEEE Vehicular Technology Conference, 0-7803-5435-4/99, Feb 1999, pp. 795-799, IEEE.
	XIE, et al., "Dynamic Location Area Management and Performance Analysis", IEEE, 0-7803-1266-x/93, 1993, pp. 536-539, IEEE.
	LEONHARDT, et al. "Towards a general location service for mobile environments", Proceedings of Third International Workshop on Services in Distributed and Networked Environments, June 1996, 8 pages (pp. 1-8 in pdf), Macau.
	Global System for Mobile Communications, "Digital cellular telecommunications system (Phase 2+); GSM Public Land Mobile Network (PLMN) access reference configuration" GSM 04.02 version 7.0.0 Release 1998, ETSI TS 100 551, V7.0.0, 1999, pp. 1-11, European Telecommunications Standards Institute, FR.
	3rd Generation Partnership Project; Technical Specification Group Services and System Aspects; 3rd Generation mobile system Release 1999 Specifications (Release 1999), 3G TS 21.101, V3.1.0, 2000, pp. 1-14, FR.
	3rd Generation Partnership Project; Technical Specification Group Services and System Aspects; Location Services (LCS); Service description, Stage 1 (Release 4), 3 GPP TS 22.071, V4.3.0, 2001, pp. 1-40, FR.
	3rd Generation Partnership Project; Technical Specification Group Radio Access Networks; Base station conformance testing (FDD) (Release 1999), 3GPP TS 25.141, V3.5.0, 2001, pp. 1-103, FR.
	3rd Generation Partnership Project; Technical Specification Group Radio Access Network; Physical layer procedures (FDD) (Release 1999), 3GPP TS 25.214, V3.6.0, 2001, pp. 1-6, FR.
	3rd Generation Partnership Project; Technical Specification Group Radio Access Network; UE Procedures in Idle Mode and Procedures for Cell Reselection in Connected Mode (Release 1999), 3GPP TS 25.304, V3.6.0, 2001, pp. 1-41, FR.
	ACHARYA, et al., "Mobility Management in Wireless ATM Networks", IEEE Communications Magazine, 0163-6804/97, November 1997, pp. 100-109, IEEE.
	AKYOL, et al., "Rerouting for Handoff in a Wireless ATM Network" IEEE Personal Communications, 1070-9916/96, October 1996, pp. 26-33, IEEE.
	AKYOL, et al., "Handling Mobility in a Wireless ATM Network", IEEE, 0743-166X/96, 1996, pp. 1405-1413, IEEE.
	LIU, et al., "Mobility Modeling, Location Tracking, and Trajectory Prediction in Wireless ATM Networks", IEEE Journal on Selected Areas in Communications, Vol. 16, No. 6, 0733-8716/98, August 1998, pp. 922-936, IEEE.
	BALAKRISHNAN, et al., "Improving reliable transport and handoff performance in cellular wireless networks", Wireless Networks 1, 1995, pp. 469-481, J.C. Baltzer AG, Science Publishers.
	AHONEN, et al., "Cellular network optimisation based on mobile location", IST-2000-25382-CELLO, Cellular Location Technology, Information Society Technologies, 2001, 51 pages (pp. 1-51 in pdf), Cello Consortium

Examiner: /AJIT PATEL/ Date Considered: 01/05/2018

EXAMINER: Initial if reference considered, whether or not citation is in conformance with MPEP 609; Draw line through citation if not in conformance and not considered. Include copy of this form with next communication to applicant.

ALL REFERENCES CONSIDERED EXCEPT WHERE LINED THROUGH. /A.P/

PTO/SB/(08-03)  
 Approved for use through 07/31/2008. OMB 0651-0031  
 U.S. Patent and Trademark Office. U.S. DEPARTMENT OF COMMERCE

Under the Paperwork Reduction Act of 1995, no persons are required to respond to a collection of information unless it displays a valid OMB control number

Substitute for form 1449/PTO  <b>INFORMATION DISCLOSURE                  STATEMENT BY APPLICANT</b>	<b>Complete if Known</b>	
	Application Number	15/717,138
	Filing Date	09/27/2017
	First Named Inventor	Reed
	Examiner Name	PATEL, AJIT
	Art Unit	2644
	Attorney Docket No.	TX1000-C7

**NON PATENT LITERATURE**

Examiner Initial	Include name of author (in CAPITAL LETTERS), title of the article (when appropriate), title of the item (book, magazine, journal, serial, symposium, catalog, etc.), date, page(s), volume-issue number(s), publisher, city and/or country where published.
	RAYCHAUDHURI, et al., "WATMnet: A Prototype Wireless ATM System for Multimedia Personal Communication", IEEE Journal on Selected Areas in Communications, vol.15, no. 1, 0733-8716/97, January 1997, pp. 83-95, IEEE.
	SMALL, "Location Determination in a Wireless LAN Infrastructure", Master's Thesis, Dept. of Electrical and Computer Engineering, 2000, pp. 1-37, Carnegie Mellon University
	STEELE, et al., "Mobile Radio Communications; Second Edition; Second and Third Generation Cellular and WATM Systems", 1999, 20 pages (pp. 1-20 in pdf), John Wiley and Sons Ltd., England
	International Telecommunication Union, "Specifications of Measuring Equipment; Basic Parameters for the Measurement of Error Performance at Bit Rates Below the Primary Rate", CCITT, Recommendation O.153, October 1992, 8 pages (pp. 1-8 in pdf), ITU.
	VARSHNEY, et al., "Mobile Commerce: A New Frontier", Computer, 0018-9162/00, October 2000, pp. 32-38, IEEE
	VEERARAGHAVAN, et al., "Mobility and Connection Management in a Wireless ATM Lane", IEEE Journal on Selected Areas in Communications, vol. 15, no. 1, 0733-8716/97, January 1997, pp. 50-68, IEEE.
	YAMAMOTO, et al., "Position Location Technologies Using Signal Strength in Cellular Systems", VTC '01, 0-7803-6728-6/01, 2001, pp. 2570-2574, IEEE.
	YU, et al., "Adaptive Resource Allocation for Prioritized Call Admission over an ATM-Based Wireless PCN", IEEE Journal on Selected Areas in Communications, vol. 15, no. 7, 0733-8716/97, September 1997, pp. 1208-1225, IEEE.
	YUAN, et al., "A signaling and control architecture for mobility support in wireless ATM networks", Mobile Networks and Applications 1, 1996, pp. 287-298, J.C. Baltzer AG, Science Publishers.
	CHIASSON, et al., "Field Measurements of a Prototype Slow Frequency Hop Personal Communication System", 0-7803-2742-X/95, 1995, pp. 118-124, IEEE.
	ERCEG, et al., "An Empirically Based Path Loss Model for Wireless Channels in Suburban Environments", IEEE Journal on Selected Areas in Communications, vol. 17, no. 1, 0733-8716/99, July 1999, pp. 1205-1211, IEEE.
	FUJII, et al., "Experimental Research on Inter-Vehicle Communication using Infrared Rays", IEEE, 0-7803-3652-6/96, 1996, 6 pages (pp. 1-6 in pdf), IEEE.
	KNEBELKAMP, et al., "Field Test of a CDMA System", IEEE, 0-7803-1927-3/94, 1994, pp. 1-5, IEEE
	LI, et al., "Performance Evaluation of a Cellular Base Station Multibeam Antenna", IEEE Transactions on Vehicular Technology, vol. 46, no. 1, 0018-9545/97, February 1997, pp. 1-9, IEEE.
	REED, et al., "An Overview of the Challenges and Progress in Meeting the E-911 Requirement for Location Service", IEEE Communications Magazine, 0163-6804/98, April 1998, pp. 30-37, IEEE.
	REUDINK, "Cellular Network Design and Smart Antenna Systems", RAWCON'98 Proceedings, 0-7803-4988-1/98, 1998, pp. 19-22, IEEE.

Examiner: /AJIT PATEL/ Date Considered: 01/05/2018

EXAMINER: Initial if reference considered, whether or not citation is in conformance with MPEP 609; Draw line through citation if not in conformance and not considered. Include copy of this form with next communication to applicant.

ALL REFERENCES CONSIDERED EXCEPT WHERE LINED THROUGH. /A.P/

Under the Paperwork Reduction Act of 1995, no persons are required to respond to a collection of information unless it displays a valid OMB control number

Substitute for form 1449/PTO  <b>INFORMATION DISCLOSURE                  STATEMENT BY APPLICANT</b>	<b>Complete if Known</b>	
	Application Number	15/717,138
	Filing Date	09/27/2017
	First Named Inventor	Reed
	Examiner Name	PATEL, AJIT
	Art Unit	2644
Attorney Docket No.	TX1000-C7	

**NON PATENT LITERATURE**

Examiner Initial	Include name of author (in CAPITAL LETTERS), title of the article (when appropriate), title of the item (book, magazine, journal, serial, symposium, catalog, etc.), date, page(s), volume-issue number(s), publisher, city and/or country where published.
	XIA, et al., "Radio Propagation Characteristics for Line-of-Sight Microcellular and Personal Communications", IEEE Transactions on Antennas and Propagation, vol. 41, no. 10, 0018-926X/93, October 1993, pp. 1439-1447, IEEE.
	BATARIERE, et al., "Wideband MIMO Mobile Impulse Response Measurement at 3.7 GHz", VTC 2002, 0-7803-7484-3/02, 2002, pp. 26-30, IEEE.
	BIN, et al., "Field test of HTS receivers on CDMA demonstration cluster in China", Chinese Science Bulletin, vol. 54, no. 4, Feb. 2009, pp. 612-615, Science in China Press, China.
	HYNICICA, et al., "Urban Vehicle-to-Infrastructure Wireless Communications Range Evaluation", 15 <sup>th</sup> International IEEE Conference on Intelligent Transportation Systems, 978-1-4673-3063-3/12, 16-19 September 2012, pp. 915-920, IEEE, US.
	IMPERATORE, et al., "Path Loss Measurements at 3.5 GHz: A Trial Test WiMax Based in Rural Environment", IEEE Tridentcom 2007, May 2007, 8 pages (pp. 1-8 in pdf), US
	NILSSON, et al., "Multipath Propagation Simulator for V2X Communication Tests on Cars; Design Aspects and Feasibility Experiments", 7 <sup>th</sup> European Conference on Antennas and Propagation (EuCAP), 978-88-907018-3-2/13, 2013, pp. 1342-1346, IEEE.
	RIBLETT, et al., "Findings on the Suitability of 802.11 for Highly Mobile Broadband Networks", 978-1-4244-5239-2/09, 2009, pp. 1-7, IEEE.
	SCHAFFNER, et al., "A Drive Test Measurement Approach to Characterize On-Vehicle 2x2 LTE-MIMO Antennas", 978-1-4673-5692-3/13, 2013, pp. 85-88, IEEE.
	SCHUMACHER, et al., "Vehicle-to-Vehicle IEEE 802.11p Performance Measurements at Urban Intersections", Intelligent Vehicular Networking: V2V/V2I Communications and Applications, 978-1-4577-2053-6/12, 2012, pp. 7131-7135, IEEE.
	TAO, et al., "An Overview of Cooperative Communications", LTE-Advanced and 4G Wireless Communications: Part 2, IEEE Communications Magazine, 0163-6804/12, June 2012, pp. 65-71, IEEE.
	XIA, et al., "Field Operational Testing of ECO-Approach Technology at a Fixed-Time Signalized Intersection", 15 <sup>th</sup> International IEEE Conference on Intelligent Transportation Systems, 978-1-4673-3063-3/12, 16-19 September 2012, pp. 188-193, IEEE, US.
	ZHANG, et al., "Application of Drive Test for QoS Evaluation in 3G Wireless Networks", Proceedings of ICCT 2003, 2003, pp. 1206-1209.
	KUBBAR, et al., "Multiple Access Control Protocols for Wireless ATM: Problems Definition and Design Objectives", IEEE Communications Magazine, 0163-6804/97, November 1997, pp. 93-99, IEEE.
	NAYLON, et al., "Low-Latency Handover in a Wireless ATM LAN", IEEE Journal on Selected Areas in Communications, vol. 16, no. 6, 0733-8716/98, August 1998, pp. 909-921, IEEE.
	RAMASWAMY, et al., "PCS Network Survivability", IEEE, 0-7803-5668-3/99, 1999, pp. 1028-1032, IEEE.
	HARTER, et al., "A Distributed Location System for the Active Office", IEEE Network, 0890-8044/94, January/February 1994, pp. 62-70, IEEE.

Examiner: /AJIT PATEL/ Date Considered: 01/05/2018

EXAMINER: Initial if reference considered, whether or not citation is in conformance with MPEP 609; Draw line through citation if not in conformance and not considered. Include copy of this form with next communication to applicant.

ALL REFERENCES CONSIDERED EXCEPT WHERE LINED THROUGH. /A.P/



<b>Search Notes</b>  	<b>Application/Control No.</b>  15717138	<b>Applicant(s)/Patent Under Reexamination</b>  REED ET AL.
	<b>Examiner</b>  AJIT PATEL	<b>Art Unit</b>  2644

CPC- SEARCHED		
Symbol	Date	Examiner
H04W4/023;H04B17/318;G01S5/0252;H04W4/028	12/10/2017	AP
(H04W\$/\$.CPC.	12/10/2017	AP
(H04B\$/\$.CPC.	12/10/2017	AP
(G01S\$/\$.CPC.	12/10/2017	AP

CPC COMBINATION SETS - SEARCHED		
Symbol	Date	Examiner

US CLASSIFICATION SEARCHED			
Class	Subclass	Date	Examiner

\* See search history printout included with this form or the SEARCH NOTES box below to determine the scope of the search.

SEARCH NOTES		
Search Notes	Date	Examiner
Inventor name search	12/10/2017	AP
EAST	12/10/2017	AP
EAST	1/5/2018	AP

INTERFERENCE SEARCH			
US Class/ CPC Symbol	US Subclass / CPC Group	Date	Examiner
	See EAST for interference search	12/10/2017	AP

--	--

## EAST Search History

## EAST Search History (Prior Art)

Ref #	Hits	Search Query	DBs	Default Operator	Plurals	Time Stamp
L1	30	((("6662014") or ("5023900") or ("7203752") or ("20020173318") or ("5812636") or ("6223032") or ("6266013") or ("6238003") or ("6757543") or ("6904013") or ("6430397") or ("20010049263") or ("6360102") or ("6442391") or ("6505048") or ("7085555") or ("6678516") or ("5471649") or ("5857155") or ("5425076") or ("6445917") or ("6859463") or ("6188883") or ("6128507") or ("5875398") or ("6285688") or ("6839560") or ("6353902") or ("6453152") or ("5245610")).PN.	US-PGPUB; USPAT	OR	OFF	2018/01/05 13:59
L2	30	((("5694451") or ("6225589") or ("6687504") or ("6317596") or ("5570373") or ("5790940") or ("5757810") or ("5884163") or ("5802473") or ("6445916") or ("6154638") or ("7093286") or ("6442393") or ("5603093") or ("5706333") or ("6640101") or ("6144861") or ("20020072358") or ("6487394") or ("6847916") or ("5933776") or ("6560461") or ("6072778") or ("6061561") or ("5819177") or ("6775544") or ("6594483") or ("8199696") or ("7072648") or ("6070083")).PN.	US-PGPUB; USPAT	OR	OFF	2018/01/05 14:10
L3	7	((("6636744") or ("4912705") or ("5526357") or ("5548593") or ("20020198985") or ("20030091017") or ("20050282540")).PN.	US-PGPUB; USPAT	OR	OFF	2018/01/05 14:19

1/ 5/ 2018 2:19:38 PM

C:\Users\apatel\Documents\EAST\Workspaces\15464820.AL.wsp

Under the Paperwork Reduction Act of 1995, no persons are required to respond to a collection of information unless it displays a valid OMB control number.

Substitute for form 1449/PTO  <b>INFORMATION DISCLOSURE STATEMENT BY APPLICANT</b>	<b>Complete if Known</b>
	Application Number <b>15/717,138</b>
	Filing Date                09/27/2017
	First Named Inventor    Reed
	Examiner Name            PATEL, AJIT
	Art Unit                     2644
	Attorney Docket No.     TX1000-C7

Examiner Initials	Document Number	Publication Date MM-DD-YYYY	Name of Patentee or Applicant of Cited Document	Pages, Columns, Lines, Where Relevant Passages or Relevant Figures Appear
	US 6,662,014-B1	12-09-2003	Walsh	
	US 5,023,900	06-11-1991	Tayloe, et al.	
	US 7,203,752-B2	04-10-2007	Rice, et al.	
	US 20020173318-A1	11-21-2002	Dyer	
	US 5,812,636	09-22-1998	Tseng, et al.	
	US 6,223,032-B1	04-24-2001	Cuffaro	
	US 6,266,013-B1	07-24-2001	Stilp, et al.	
	US 6,138,003	10-24-2000	Kingdon, et al.	
	US 6,757,543-B2	06-29-2004	Moran, et al.	
	US 6,904,013-B2	06-07-2005	Skoog, et al.	
	US 6,430,397-B1	08-06-2002	Willrett	
	US 20010049263-A1	12-06-2001	Zhang	
	US-6,360,102-B1	03-19-2002	Havinis, et al.	
	US-6,442,391-B1	08-27-2002	Johansson, et al.	
	US-6,505,048-B1	01-07-2003	Moles, et al.	
	US-7,085,555-B2	08-01-2006	Zellner, et al.	
	US-6,678,516-B2	01-13-2004	Nordman, et al.	
	US-5,471,649	11-28-1995	Rees, et al.	
	US-5,857,155	01-05-1999	Hill, et al.	
	US-5,425,076	06-13-1995	Knippelmier	
	US-6,445,917-B1	09-03-2002	Bark, et al.	
	US-6,859,463-B1	02-22-2005	Mayor, et al.	
	US-6,188,883-B1	02-13-2001	Takemura	
	US-6,128,507	10-03-2000	Takai	
	US-5,875,398	02-23-1999	Snapp	
	US-6,285,688-B1	09-04-2001	Henderson, et al.	
	US-6,839,560-B1	01-04-2005	Bahl, et al.	
	US-6,353,902-B1	03-05-2002	Kulatunge, et al.	
	US-6,453,152-B1	09-17-2002	Hong, et al.	
	US-5,245,610	09-14-1993	Lindell	

Examiner: \_\_\_\_\_

Date Considered: \_\_\_\_\_

EXAMINER: Initial if reference considered, whether or not citation is in conformance with MPEP 609; Draw line through citation if not in conformance and not considered. Include copy of this form with next communication to applicant.

Under the Paperwork Reduction Act of 1995, no persons are required to respond to a collection of information unless it displays a valid OMB control number

Substitute for form 1449/PTO  <b>INFORMATION DISCLOSURE STATEMENT BY APPLICANT</b>	<b>Complete if Known</b>
	Application Number <b>15/717,138</b>
	Filing Date                09/27/2017
	First Named Inventor    Reed
	Examiner Name            PATEL, AJIT
	Art Unit                      2644
	Attorney Docket No.      TX1000-C7

Examiner Initials	Document Number	Publication Date MM-DD-YYYY	Name of Patentee or Applicant of Cited Document	Pages, Columns, Lines, Where Relevant Passages or Relevant Figures Appear
	US-5,694,451	12-02-1997	Arinell	
	US-6,226,589-B1	05-01-2001	Maeda, et al.	
	US-6,687,504-B1	02-03-2004	Raith	
	US-6,317,596-B1	11-13-2001	Elwin	
	US-5,570,373	10-29-1996	Wing	
	US-5,790,940	08-04-1998	Laborde, et al.	
	US-5,757,810	05-26-1998	Fall	
	US-5,884,163	03-16-1999	Hardouin	
	US-5,802,473	09-01-1998	Rutledge, et al.	
	US-6,445,916-B1	09-03-2002	Rahman	
	US-6,154,638	11-28-2000	Cheng, et al.	
	US-7,093,286-B1	08-15-2006	King	
	US-6,442,393-B1	08-27-2002	Hogan	
	US-5,603,093	02-11-1997	Yoshimi, et al.	
	US-5,706,333	01-06-1998	Grenning, et al.	
	US-6,640,101-B1	10-28-2003	Daniel	
	US-6,144,861	11-07-2000	Sundelin, et al.	
	US-20020072358-A1	06-13-2002	Schneider, et al.	
	US-6,487,394-B1	11-26-2002	Ue, et al.	
	US-6,847,916-B1	01-25-2005	Ying	
	US-5,933,776	08-03-1999	Kirkpatrick	
	US-6,560,461-B1	05-06-2003	Fomukong, et al.	
	US-6,072,778	06-06-2000	Labedz, et al.	
	US-6,061,561	05-09-2000	Alanara, et al.	
	US-5,819,177	10-06-1998	Vucetic, et al.	
	US-6,775,544-B2	08-10-2004	Ficarra	
	US-6,594,483-B2	07-15-2003	Nykanen, et al.	
	US-8,199,696-B2	06-12-2012	Sarkar, et al.	
	US-7,072,648-B2	07-04-2006	Ichikawa	
	US-6,070,083	05-30-2000	Watters, et al.	

Examiner: \_\_\_\_\_

Date Considered: \_\_\_\_\_

EXAMINER: Initial if reference considered, whether or not citation is in conformance with MPEP 609; Draw line through citation if not in conformance and not considered. Include copy of this form with next communication to applicant.

Under the Paperwork Reduction Act of 1995, no persons are required to respond to a collection of information unless it displays a valid OMB control number

Substitute for form 1449/PTO  <b>INFORMATION DISCLOSURE STATEMENT BY APPLICANT</b>	<b>Complete if Known</b>
	Application Number <b>15/717,138</b>
	Filing Date                09/27/2017
	First Named Inventor    Reed
	Examiner Name            PATEL, AJIT
	Art Unit                    2644
	Attorney Docket No.    TX1000-C7

Examiner Initials	Document Number	Publication Date MM-DD-YYYY	Name of Patentee or Applicant of Cited Document	Pages, Columns, Lines, Where Relevant Passages or Relevant Figures Appear
	US-6,636,744-B1	10-21-2003	Da	
	US-4,912,705	03-27-1990	Paneth, et al.	
	US-5,526,357	06-11-1996	Jandrell	
	US-5,548,583	08-20-1996	Bustamante	
	US-20020198985-A1	12-26-2002	Fraenkel, et al.	
	US-20030091017-A1	05-15-2003	Davenport, et al.	
	US-20050282540-A1	12-22-2005	Motamedi, et al.	

FOREIGN PATENT DOCUMENTS				
Examiner Initial	Foreign Patent Document	Publication Date MM-DD-YYYY	Name of Patentee or Applicant of Cited Document	Pages, Columns, Lines, Where Relevant Passages or Relevant Figures Appear
	WO 1999012228 A2	03-11-1999	Ameritec Corp.	
	EP 1 071 295 A2	01-24-2001	Phone.Com Inc.	
	JPH07-250381 A	09-26-1995	Fujitsu Ltd.	
	JP 2000-091982	03-31-2000	NEC Corp.	
	JPH11-027729 A	01-29-1999	Sanyo Electric Co.	
	WO 2000010296 A2	02-24-2000	SC-Wireless, Inc.	
	EP 1 126 376 A1	08-22-2001	NTT DoCoMo, Inc.	
	WO 2001076093 A1	10-11-2001	True-Position, Inc.	
	WO 1990004293 A1	04-19-1990	Motorola, Inc.	
	GB 2 252 475 A	08-05-1992	Motorola, Inc.	
	WO 2000028756 A1	05-18-2000	Telefonaktiebolaget L M Ericsson	
	GB 2 357 010 A	06-06-2001	Telefonaktiebolaget L M Ericsson	
	EP 0 714 589 B1	05-06-2004	Borkowski, et al.	
	EP 1 028 543 A1	08-16-2000	Lucent Technologies Inc.	
	WO 1995012268 A1	05-04-1995	Bellsouth Corporation	
	WO 2001046710 A2	06-28-2001	Grid Data, Inc.	
	WO 2000040992 A1	07-13-2000	Trueposition, Inc.	
	WO 2000041402 A2	07-13-2000	Trueposition, Inc.	
	WO 2000077949 A1	12-21-2000	Time Domain Corporation	

Examiner: \_\_\_\_\_

Date Considered: \_\_\_\_\_

EXAMINER: Initial if reference considered, whether or not citation is in conformance with MPEP 609; Draw line through citation if not in conformance and not considered. Include copy of this form with next communication to applicant.

Under the Paperwork Reduction Act of 1995, no persons are required to respond to a collection of information unless it displays a valid OMB control number

Substitute for form 1449/PTO          <b>INFORMATION DISCLOSURE STATEMENT BY APPLICANT</b>	<b>Complete if Known</b>
	Application Number <b>15/717,138</b>
	Filing Date            09/27/2017
	First Named Inventor    Reed
	Examiner Name         PATEL, AJIT
	Art Unit                 2644
	Attorney Docket No.    TX1000-C7

**NON PATENT LITERATURE**

Examiner Initial	Include name of author (in CAPITAL LETTERS), title of the article (when appropriate), title of the item (book, magazine, journal, serial, symposium, catalog, etc.), date, page(s), volume-issue number(s), publisher, city and/or country where published.
	VUCETIC, et al. "Signal Monitoring System for Wireless Network Operation and Management", Dynamic Telecommunications, Inc., 0-7803-5030-8/98, 1998, pp. 296-300, IEEE
	3rd Generation Partnership Project: Technical Specification Group Radio Access Network: RRC Protocol Specification, 3GPP TS 25.331, V3.6.0 (2001-03), Release 1999, 2001, pp. 1-708, France
	3rd Generation Partnership Project: Technical Specification Group Services and System Aspects: Functional Stage 2 Description of LCS (Release 4), 3G TS 23.271, v 2.0.0 (2000-12) 2000, pps. 1-57, FR
	BENNINGTON, et al. "Wireless Andrew: Experience Building a High Speed, Campus-Wide Wireless Data Network", MOBICOM 97, ACM 0-89791-988-2/97/9, 1997, pp. 55-65, Budapest, Hungary
	ANHALT, et al., "Toward Context Aware Computing: Experiences and Lessons," IEEE Intelligent Systems, 1094-7167/01, May/June 2001, pp. 38-46. IEEE.
	ECKHARDT, et al. "Measurement and Analysis of the Error Characteristics of an In-Building Wireless Network", Proceedings of SIGCOMM '96, Aug. 1996, pp. 1-12 (12 pages in pdf), Stanford, CA.
	HE, et al., "WaveGuard: Secure Location Service for Wireless Andrew," Wireless 2001, 13 <sup>th</sup> International Conference on Wireless Communications, Proceedings vol. 1, 9-11 July 2001, pp. 252-259, CA.
	HILLS, "Large-Scale Wireless LAN Design," IEEE Communications Magazine, 0163-6804/01, Nov 2001, pp. 98-104, IEEE.
	HILLS, "Bringing Mobile Computing to a University Community of 10,000," IEEE Spectrum, 0018-9235/99, June 1999, pp. 49-53, IEEE.
	HILLS, et al, "Seamless access to multiple wireless data networks; A Wireless Data Network Infrastructure at Carnegie Mellon University," IEEE Personal Communications, vol. 3, no. 1, 1070-9916/96, February 1996, pp. 56-63, IEEE
	JOHNSON, et al., "Truly seamless wireless and mobile host networking; Protocols for Adaptive Wireless and Mobile Networking," IEEE Personal Communications, 1070-9916/96, February 1996, pp. 34-42, IEEE.
	SMALL, et al., "Determining User Location for Context Aware Computing Through the Use of a Wireless LAN Infrastructure", 2000, 8 pages (pp. 1-8 in pdf), Institute for Complex Engineered Systems, Carnegie Mellon University, Pittsburgh, PA.
	HASSAN, "Cellular Optimization", Cellular Business, September 1995, pp. 122-126
	MILETIC, "Looking for Trouble", Wireless Review, 15 January 2001, pp. 52-54.
	BISDIKIAN, et al., "Enabling Location-Based Applications", WMC 01, ACM 2001 1-58113-376-6/01/07, 2001, pp. 38-42, Rome, Italy.
	ATENIESE, et al. "Untraceable Mobility or How to Travel Incognito", Computer Networks 31, 1389-1286/99, 1999, pp. 871-884, Elsevier Science B.V.
	LEE, et al., "Enhanced privacy and authentication for the global system for mobile communications", Wireless Networks 5, 1999, pp. 231-243, Science Publishers, J.C. Baltzer.
	BERA, et al., "Performance Analysis of Dynamic Location Updation Strategies for Mobile Users", Proc. Of 2000 International Conference on Distributed Computing Systems, April 2000, 8 pages (pp. 1-8 in pdf), Taiwan.

Examiner:

Date Considered:

EXAMINER: Initial if reference considered, whether or not citation is in conformance with MPEP 609; Draw line through citation if not in conformance and not considered. Include copy of this form with next communication to applicant.

Substitute for form 1449/PTO  <b>INFORMATION DISCLOSURE STATEMENT BY APPLICANT</b>	<b>Complete if Known</b>	
	Application Number	15/717,138
	Filing Date	09/27/2017
	First Named Inventor	Reed
	Examiner Name	PATEL, AJIT
	Art Unit	2644
Attorney Docket No.	TX1000-C7	

NON PATENT LITERATURE	
Examiner Initial	Include name of author (in CAPITAL LETTERS), title of the article (when appropriate), title of the item (book, magazine, journal, serial, symposium, catalog, etc.), date, page(s), volume-issue number(s), publisher, city and/or country where published.
	HEPSAYDIR, "Mobile Positioning in CDMA Cellular Networks", 38 <sup>th</sup> IEEE Vehicular Technology Conference, 0-7803-5435-4/99, Feb 1999, pp. 795-799, IEEE.
	XIE, et al., "Dynamic Location Area Management and Performance Analysis", IEEE, 0-7803-1266-x/93, 1993, pp. 536-539, IEEE.
	LEONHARDT, et al. "Towards a general location service for mobile environments", Proceedings of Third International Workshop on Services in Distributed and Networked Environments, June 1996, 8 pages (pp. 1-8 in pdf), Macau.
	Global System for Mobile Communications, "Digital cellular telecommunications system (Phase 2+); GSM Public Land Mobile Network (PLMN) access reference configuration" GSM 04.02 version 7.0.0 Release 1998, ETSI TS 100 551, V7.0.0, 1999, pp. 1-11, European Telecommunications Standards Institute, FR.
	3rd Generation Partnership Project; Technical Specification Group Services and System Aspects; 3rd Generation mobile system Release 1999 Specifications (Release 1999), 3G TS 21.101, V3.1.0, 2000, pp. 1-14, FR.
	3rd Generation Partnership Project; Technical Specification Group Services and System Aspects; Location Services (LCS); Service description, Stage 1 (Release 4), 3 GPP TS 22.071, V4.3.0, 2001, pp. 1-40, FR.
	3rd Generation Partnership Project; Technical Specification Group Radio Access Networks; Base station conformance testing (FDD) (Release 1999), 3GPP TS 25.141, V3.5.0, 2001, pp. 1-103, FR.
	3rd Generation Partnership Project; Technical Specification Group Radio Access Network; Physical layer procedures (FDD) (Release 1999), 3GPP TS 25.214, V3.6.0, 2001, pp. 1-6, FR.
	3rd Generation Partnership Project; Technical Specification Group Radio Access Network; UE Procedures in Idle Mode and Procedures for Cell Reselection in Connected Mode (Release 1999), 3GPP TS 25.304, V3.6.0, 2001, pp. 1-41, FR.
	ACHARYA, et al., "Mobility Management in Wireless ATM Networks", IEEE Communications Magazine, 0163-6804/97, November 1997, pp. 100-109, IEEE.
	AKYOL, et al., "Rerouting for Handoff in a Wireless ATM Network" IEEE Personal Communications, 1070-9916/96, October 1996, pp. 26-33, IEEE.
	AKYOL, et al., "Handling Mobility in a Wireless ATM Network", IEEE, 0743-166X/96, 1996, pp. 1405-1413, IEEE.
	LIU, et al., "Mobility Modeling, Location Tracking, and Trajectory Prediction in Wireless ATM Networks", IEEE Journal on Selected Areas in Communications, Vol. 16, No. 6, 0733-8716/98, August 1998, pp. 922-936, IEEE.
	BALAKRISHNAN, et al., "Improving reliable transport and handoff performance in cellular wireless networks", Wireless Networks 1, 1995, pp. 469-481, J.C. Baltzer AG, Science Publishers.
	AHONEN, et al., "Cellular network optimisation based on mobile location", IST-2000-25382-CELLO, Cellular Location Technology, Information Society Technologies, 2001, 51 pages (pp. 1-51 in pdf), Cello Consortium

Examiner:

Date Considered:

EXAMINER: Initial if reference considered, whether or not citation is in conformance with MPEP 609; Draw line through citation if not in conformance and not considered. Include copy of this form with next communication to applicant.

Under the Paperwork Reduction Act of 1995, no persons are required to respond to a collection of information unless it displays a valid OMB control number

Substitute for form 1449/PTO          <b>INFORMATION DISCLOSURE STATEMENT BY APPLICANT</b>	<b>Complete if Known</b>
	Application Number <b>15/717,138</b>
	Filing Date                09/27/2017
	First Named Inventor    Reed
	Examiner Name            PATEL, AJIT
	Art Unit                     2644
	Attorney Docket No.    TX1000-C7

**NON PATENT LITERATURE**

Examiner Initial	Include name of author (in CAPITAL LETTERS), title of the article (when appropriate), title of the item (book, magazine, journal, serial, symposium, catalog, etc.), date, page(s), volume-issue number(s), publisher, city and/or country where published.
	RAYCHAUDHURI, et al., "WATMnet: A Prototype Wireless ATM System for Multimedia Personal Communication", IEEE Journal on Selected Areas in Communications, vol.15, no. 1, 0733-8716/97, January 1997, pp. 83-95, IEEE.
	SMALL, "Location Determination in a Wireless LAN Infrastructure", Master's Thesis, Dept. of Electrical and Computer Engineering, 2000, pp. 1-37, Carnegie Mellon University
	STEELE, et al., "Mobile Radio Communications; Second Edition; Second and Third Generation Cellular and WATM Systems", 1999, 20 pages (pp. 1-20 in pdf), John Wiley and Sons Ltd., England
	International Telecommunication Union, "Specifications of Measuring Equipment; Basic Parameters for the Measurement of Error Performance at Bit Rates Below the Primary Rate", CCITT, Recommendation O.153, October 1992, 8 pages (pp. 1-8 in pdf), ITU.
	VARSHNEY, et al., "Mobile Commerce: A New Frontier", Computer, 0018-9162/00, October 2000, pp. 32-38, IEEE
	VEERARAGHAVAN, et al., "Mobility and Connection Management in a Wireless ATM Lane", IEEE Journal on Selected Areas in Communications, vol. 15, no. 1, 0733-8716/97, January 1997, pp. 50-68, IEEE.
	YAMAMOTO, et al., "Position Location Technologies Using Signal Strength in Cellular Systems", VTC '01, 0-7803-6728-6/01, 2001, pp. 2570-2574, IEEE.
	YU, et al., "Adaptive Resource Allocation for Prioritized Call Admission over an ATM-Based Wireless PCN", IEEE Journal on Selected Areas in Communications, vol. 15, no. 7, 0733-8716/97, September 1997, pp. 1208-1225, IEEE.
	YUAN, et al., "A signaling and control architecture for mobility support in wireless ATM networks", Mobile Networks and Applications 1, 1996, pp. 287-298, J.C. Baltzer AG, Science Publishers.
	CHIASSON, et al., "Field Measurements of a Prototype Slow Frequency Hop Personal Communication System", 0-7803-2742-X/95, 1995, pp. 118-124, IEEE.
	ERCEG, et al., "An Empirically Based Path Loss Model for Wireless Channels in Suburban Environments", IEEE Journal on Selected Areas in Communications, vol. 17, no. 1, 0733-8716/99, July 1999, pp. 1205-1211, IEEE.
	FUJII, et al., "Experimental Research on Inter-Vehicle Communication using Infrared Rays", IEEE, 0-7803-3652-6/96, 1996, 6 pages (pp. 1-6 in pdf), IEEE.
	KNEBELKAMP, et al., "Field Test of a CDMA System", IEEE, 0-7803-1927-3/94, 1994, pp. 1-5, IEEE
	LI, et al., "Performance Evaluation of a Cellular Base Station Multibeam Antenna", IEEE Transactions on Vehicular Technology, vol. 46, no. 1, 0018-9545/97, February 1997, pp. 1-9, IEEE.
	REED, et al., "An Overview of the Challenges and Progress in Meeting the E-911 Requirement for Location Service", IEEE Communications Magazine, 0163-6804/98, April 1998, pp. 30-37, IEEE.
	REUDINK, "Cellular Network Design and Smart Antenna Systems", RAWCON'98 Proceedings, 0-7803-4988-1/98, 1998, pp. 19-22, IEEE.

Examiner:

Date Considered:

EXAMINER: Initial if reference considered, whether or not citation is in conformance with MPEP 609; Draw line through citation if not in conformance and not considered. Include copy of this form with next communication to applicant.



Under the Paperwork Reduction Act of 1995, no persons are required to respond to a collection of information unless it displays a valid OMB control number

Substitute for form 1449/PTO           <b>INFORMATION DISCLOSURE STATEMENT BY APPLICANT</b>	<b>Complete if Known</b>
	Application Number <b>15/717,138</b>
	Filing Date            09/27/2017
	First Named Inventor   Reed
	Examiner Name         PATEL, AJIT
	Art Unit                2644
	Attorney Docket No.   TX1000-C7

NON PATENT LITERATURE	
Examiner Initial	Include name of author (in CAPITAL LETTERS), title of the article (when appropriate), title of the item (book, magazine, journal, serial, symposium, catalog, etc.), date, page(s), volume-issue number(s), publisher, city and/or country where published.
	XIA, et al., "Radio Propagation Characteristics for Line-of-Sight Microcellular and Personal Communications", IEEE Transactions on Antennas and Propagation, vol. 41, no. 10, 0018-926X/93, October 1993, pp. 1439-1447, IEEE.
	BATARIERE, et al., "Wideband MIMO Mobile Impulse Response Measurement at 3.7 GHz", VTC 2002, 0-7803-7484-3/02, 2002, pp. 26-30, IEEE.
	BIN, et al., "Field test of HTS receivers on CDMA demonstration cluster in China", Chinese Science Bulletin, vol. 54, no. 4, Feb. 2009, pp. 612-615, Science in China Press, China.
	HYNCICA, et al., "Urban Vehicle-to-Infrastructure Wireless Communications Range Evaluation", 15 <sup>th</sup> International IEEE Conference on Intelligent Transportation Systems, 978-1-4673-3063-3/12, 16-19 September 2012, pp. 915-920, IEEE, US.
	IMPERATORE, et al., "Path Loss Measurements at 3.5 GHz: A Trial Test WMax Based in Rural Environment", IEEE Tridentcom 2007, May 2007, 8 pages (pp. 1-8 in pdf), US
	NILSSON, et al., "Multipath Propagation Simulator for V2X Communication Tests on Cars; Design Aspects and Feasibility Experiments", 7 <sup>th</sup> European Conference on Antennas and Propagation (EuCAP), 978-88-907018-3-2/13, 2013, pp. 1342-1346, IEEE.
	RIBLETT, et al., "Findings on the Suitability of 802.11 for Highly Mobile Broadband Networks", 978-1-4244-5239-2/09, 2009, pp. 1-7, IEEE.
	SCHAFFNER, et al., "A Drive Test Measurement Approach to Characterize On-Vehicle 2x2 LTE-MIMO Antennas", 978-1-4673-5692-3/13, 2013, pp. 85-88, IEEE.
	SCHUMACHER, et al., "Vehicle-to-Vehicle IEEE 802.11p Performance Measurements at Urban Intersections", Intelligent Vehicular Networking: V2V/V2I Communications and Applications, 978-1-4577-2053-6/12, 2012, pp. 7131-7135, IEEE.
	TAO, et al., "An Overview of Cooperative Communications", LTE-Advanced and 4G Wireless Communications: Part 2, IEEE Communications Magazine, 0163-6804/12, June 2012, pp. 65-71, IEEE.
	XIA, et al., "Field Operational Testing of ECO-Approach Technology at a Fixed-Time Signalized Intersection", 15 <sup>th</sup> International IEEE Conference on Intelligent Transportation Systems, 978-1-4673-3063-3/12, 16-19 September 2012, pp. 188-193, IEEE, US.
	ZHANG, et al., "Application of Drive Test for QoS Evaluation in 3G Wireless Networks", Proceedings of ICCT 2003, 2003, pp. 1206-1209.
	KUBBAR, et al., "Multiple Access Control Protocols for Wireless ATM: Problems Definition and Design Objectives", IEEE Communications Magazine, 0163-6804/97, November 1997, pp. 93-99, IEEE.
	NAYLON, et al., "Low-Latency Handover in a Wireless ATM LAN", IEEE Journal on Selected Areas in Communications, vol. 16, no. 6, 0733-8716/98, August 1998, pp. 909-921, IEEE.
	RAMASWAMY, et al., "PCS Network Survivability", IEEE, 0-7803-5668-3/99, 1999, pp. 1028-1032, IEEE.
	HARTER, et al., "A Distributed Location System for the Active Office", IEEE Network, 0890-8044/94, January/February 1994, pp. 62-70, IEEE.

Examiner:

Date Considered:

**EXAMINER:** Initial if reference considered, whether or not citation is in conformance with MPEP 609; Draw line through citation if not in conformance and not considered. Include copy of this form with next communication to applicant.

## Electronic Acknowledgement Receipt

<b>EFS ID:</b>	31340460
<b>Application Number:</b>	15717138
<b>International Application Number:</b>	
<b>Confirmation Number:</b>	3036
<b>Title of Invention:</b>	INTERNET QUERIED DIRECTIONAL NAVIGATION SYSTEM WITH MOBILE AND FIXED ORIGINATING LOCATION DETERMINATION
<b>First Named Inventor/Applicant Name:</b>	Mark Jefferson Reed
<b>Customer Number:</b>	59911
<b>Filer:</b>	Andrew Mitchell Harris/Leigh Jones
<b>Filer Authorized By:</b>	Andrew Mitchell Harris
<b>Attorney Docket Number:</b>	TX1000-C7
<b>Receipt Date:</b>	27-DEC-2017
<b>Filing Date:</b>	27-SEP-2017
<b>Time Stamp:</b>	11:30:24
<b>Application Type:</b>	Utility under 35 USC 111(a)

### Payment information:

Submitted with Payment	no
------------------------	----

### File Listing:

Document Number	Document Description	File Name	File Size(Bytes)/ Message Digest	Multi Part /.zip	Pages (if appl.)
1	Non Patent Literature	Reed_AnOverviewOfChallenge s_.pdf	4363337  55f6eefaced0cd0c302deaaaf846f58a2e2a3872b	no	8

### Warnings:

<b>Information:</b>					
2	Non Patent Literature	Reudink_CellularNetworkDesign_.pdf	647297 dbda3c609e7f03d39b51479b03766247d11e2543	no	4
<b>Warnings:</b>					
<b>Information:</b>					
3	Non Patent Literature	Riblett_FindingsOnTheSuitability_.pdf	1295525 fd6130c532b799601361cc9f81c82262835aae8c	no	7
<b>Warnings:</b>					
<b>Information:</b>					
4	Non Patent Literature	Schaffner_ADiveTestMeasurement_.pdf	721571 0521895055bf73a578912df277aed6a9c914f38	no	4
<b>Warnings:</b>					
<b>Information:</b>					
5	Non Patent Literature	Schumacher_VehicleToVehicle_.pdf	1814510 a34b950a2ca45475522819ce81ce91ebf08a880b	no	5
<b>Warnings:</b>					
<b>Information:</b>					
6	Non Patent Literature	Small_DeterminingUserLocation_.pdf	622485 d4c3b82e13b9be47bb535130e7db9fc28c3d8f64	no	8
<b>Warnings:</b>					
<b>Information:</b>					
7	Non Patent Literature	Small_LocationDetermination_.pdf	4220208 7ce72e808c3c6041acbb12745e7dd5288103a7f0f	no	37
<b>Warnings:</b>					
<b>Information:</b>					
8	Non Patent Literature	Steele_MobileRadioCommunications_.pdf	2415746 5a8bfc102d8dd0d7cf8407000c7e40e6d0f65066	no	20
<b>Warnings:</b>					
<b>Information:</b>					

9	Non Patent Literature	Tao_AnOverviewOfCooperativ eComm_.pdf	1630721	no	7
			28756bdeaf5a18021834cbabd59e3c1838 456a3		
<b>Warnings:</b>					
<b>Information:</b>					
10	Non Patent Literature	Varshney_MobileCommerce_ pdf	1174481	no	7
			f6f4dc6e58102cef9c9653f4aa0a665cba83f a8b		
<b>Warnings:</b>					
<b>Information:</b>					
11	Non Patent Literature	Veeraraghavan_MobilityAndCo nnectionMgmt_.pdf	2254756	no	19
			f1ab404baece745db3158c6f4ccb909688c5 b935		
<b>Warnings:</b>					
<b>Information:</b>					
12	Non Patent Literature	VUCETIC_SignalMontoringSyst em_.pdf	1117531	no	5
			2e339d1da910d21e7f805b3b2172df96c02 25ec2		
<b>Warnings:</b>					
<b>Information:</b>					
13	Foreign Reference	WO0010296A2.pdf	3012824	no	69
			acae282d2a545608bf19a6b3082c61b6f4e 2e11		
<b>Warnings:</b>					
<b>Information:</b>					
14	Foreign Reference	WO0040992A1.pdf	6652634	no	148
			402aec35006e4d934ac2c02c98089502c0c 8da18		
<b>Warnings:</b>					
<b>Information:</b>					
15	Foreign Reference	WO0041402A2.pdf	7293163	no	154
			8a2eccfbb50036039da144b2fdb973f967b b8086		
<b>Warnings:</b>					
<b>Information:</b>					

16	Foreign Reference	WO0077949A1.pdf	3842859	no	106
			d23c207fe8453e1adb6f653eb0588342adb40446		
<b>Warnings:</b>					
<b>Information:</b>					
17	Foreign Reference	WO0146710A2.pdf	11211502	no	217
			8745594d89b62e9a50f45f43bc3829ecf6ee8d17		
<b>Warnings:</b>					
<b>Information:</b>					
18	Foreign Reference	WO9512268A1.pdf	3982054	no	120
			08d248fcb29230a4e7da203e42073c569b9321a		
<b>Warnings:</b>					
<b>Information:</b>					
19	Foreign Reference	WO199004293.pdf	473210	no	18
			a67fe1b7123f94bad2e381ed0a080bca1ebf5e6a		
<b>Warnings:</b>					
<b>Information:</b>					
20	Foreign Reference	WO1999012228.pdf	1347244	no	34
			fe586a0795646b5cfb9876b6b5d11521d5c49ba80		
<b>Warnings:</b>					
<b>Information:</b>					
21	Foreign Reference	WO2000028756.pdf	1072376	no	28
			1377ca4afcbcd573b226a5c898de8d9b060229ff		
<b>Warnings:</b>					
<b>Information:</b>					
22	Foreign Reference	WO2001076093.pdf	8364938	no	160
			8c72e0600936d85d268b521102f5f7a099bbf629		
<b>Warnings:</b>					
<b>Information:</b>					

23	Non Patent Literature	Xia_FieldOperationalTesting_.pdf	972176 3d30b5d462234cf1340fea93826abba39ec6b5e	no	6
<b>Warnings:</b>					
<b>Information:</b>					
24	Non Patent Literature	Xie_DynamicLocationArea_.pdf	1341081 7464eb1e55517a24bfa3478581dbe1b1a935f804	no	4
<b>Warnings:</b>					
<b>Information:</b>					
25	Non Patent Literature	Yamamoto_PositionLocationTech_.pdf	621638 6cdd938deb95166c477c899043bbf2b7cee5eb527	no	5
<b>Warnings:</b>					
<b>Information:</b>					
26	Non Patent Literature	Yu_AdaptiveResourceAllocation_.pdf	2911624 5fef0402cb5f05d6b59435e11a6954842b1203d8	no	18
<b>Warnings:</b>					
<b>Information:</b>					
27	Non Patent Literature	Yuan_ASignalingAndControlArchitecture_.pdf	1432666 979280635ee9c858d5712fba9e195f1bbd0fe219	no	12
<b>Warnings:</b>					
<b>Information:</b>					
28	Non Patent Literature	Zhang_ApplicationOfDriveTest_.pdf	724482 f9a9b1653cfc324ee79484f55ff0f2304e2d68	no	4
<b>Warnings:</b>					
<b>Information:</b>					
29	Non Patent Literature	Xia_RadioPropagation_.pdf	1112350 a1f2d309b96871c8a628699196fb60a1ed3b1307	no	9
<b>Warnings:</b>					
<b>Information:</b>					
<b>Total Files Size (in bytes):</b>			78646989		

**This Acknowledgement Receipt evidences receipt on the noted date by the USPTO of the indicated documents, characterized by the applicant, and including page counts, where applicable. It serves as evidence of receipt similar to a Post Card, as described in MPEP 503.**

**New Applications Under 35 U.S.C. 111**

**If a new application is being filed and the application includes the necessary components for a filing date (see 37 CFR 1.53(b)-(d) and MPEP 506), a Filing Receipt (37 CFR 1.54) will be issued in due course and the date shown on this Acknowledgement Receipt will establish the filing date of the application.**

**National Stage of an International Application under 35 U.S.C. 371**

**If a timely submission to enter the national stage of an international application is compliant with the conditions of 35 U.S.C. 371 and other applicable requirements a Form PCT/DO/EO/903 indicating acceptance of the application as a national stage submission under 35 U.S.C. 371 will be issued in addition to the Filing Receipt, in due course.**

**New International Application Filed with the USPTO as a Receiving Office**

**If a new international application is being filed and the international application includes the necessary components for an international filing date (see PCT Article 11 and MPEP 1810), a Notification of the International Application Number and of the International Filing Date (Form PCT/RO/105) will be issued in due course, subject to prescriptions concerning national security, and the date shown on this Acknowledgement Receipt will establish the international filing date of the application.**



UNITED STATES PATENT AND TRADEMARK OFFICE

UNITED STATES DEPARTMENT OF COMMERCE
United States Patent and Trademark Office
Address: COMMISSIONER FOR PATENTS
P.O. Box 1450
Alexandria, Virginia 22313-1450
www.uspto.gov

NOTICE OF ALLOWANCE AND FEE(S) DUE

59911 7590 12/13/2017
MITCH HARRIS, LLC - GENERAL
P.O. BOX 1269
ATHENS, GA 30603-1269

EXAMINER
PATEL, AJIT

ART UNIT PAPER NUMBER
2644

DATE MAILED: 12/13/2017

Table with 5 columns: APPLICATION NO., FILING DATE, FIRST NAMED INVENTOR, ATTORNEY DOCKET NO., CONFIRMATION NO.
15/717,138 09/27/2017 Mark Jefferson Reed TX1000-C7 3036

TITLE OF INVENTION: INTERNET QUERIED DIRECTIONAL NAVIGATION SYSTEM WITH MOBILE AND FIXED ORIGINATING LOCATION DETERMINATION

Table with 7 columns: APPLN. TYPE, ENTITY STATUS, ISSUE FEE DUE, PUBLICATION FEE DUE, PREV. PAID ISSUE FEE, TOTAL FEE(S) DUE, DATE DUE
nonprovisional SMALL \$480 \$0 \$0 \$480 03/13/2018

THE APPLICATION IDENTIFIED ABOVE HAS BEEN EXAMINED AND IS ALLOWED FOR ISSUANCE AS A PATENT. PROSECUTION ON THE MERITS IS CLOSED. THIS NOTICE OF ALLOWANCE IS NOT A GRANT OF PATENT RIGHTS. THIS APPLICATION IS SUBJECT TO WITHDRAWAL FROM ISSUE AT THE INITIATIVE OF THE OFFICE OR UPON PETITION BY THE APPLICANT. SEE 37 CFR 1.313 AND MPEP 1308.

THE ISSUE FEE AND PUBLICATION FEE (IF REQUIRED) MUST BE PAID WITHIN THREE MONTHS FROM THE MAILING DATE OF THIS NOTICE OR THIS APPLICATION SHALL BE REGARDED AS ABANDONED. THIS STATUTORY PERIOD CANNOT BE EXTENDED. SEE 35 U.S.C. 151. THE ISSUE FEE DUE INDICATED ABOVE DOES NOT REFLECT A CREDIT FOR ANY PREVIOUSLY PAID ISSUE FEE IN THIS APPLICATION. IF AN ISSUE FEE HAS PREVIOUSLY BEEN PAID IN THIS APPLICATION (AS SHOWN ABOVE), THE RETURN OF PART B OF THIS FORM WILL BE CONSIDERED A REQUEST TO REAPPLY THE PREVIOUSLY PAID ISSUE FEE TOWARD THE ISSUE FEE NOW DUE.

HOW TO REPLY TO THIS NOTICE:

I. Review the ENTITY STATUS shown above. If the ENTITY STATUS is shown as SMALL or MICRO, verify whether entitlement to that entity status still applies.

If the ENTITY STATUS is the same as shown above, pay the TOTAL FEE(S) DUE shown above.

If the ENTITY STATUS is changed from that shown above, on PART B - FEE(S) TRANSMITTAL, complete section number 5 titled "Change in Entity Status (from status indicated above)".

For purposes of this notice, small entity fees are 1/2 the amount of undiscounted fees, and micro entity fees are 1/2 the amount of small entity fees.

II. PART B - FEE(S) TRANSMITTAL, or its equivalent, must be completed and returned to the United States Patent and Trademark Office (USPTO) with your ISSUE FEE and PUBLICATION FEE (if required). If you are charging the fee(s) to your deposit account, section "4b" of Part B - Fee(s) Transmittal should be completed and an extra copy of the form should be submitted. If an equivalent of Part B is filed, a request to reapply a previously paid issue fee must be clearly made, and delays in processing may occur due to the difficulty in recognizing the paper as an equivalent of Part B.

III. All communications regarding this application must give the application number. Please direct all communications prior to issuance to Mail Stop ISSUE FEE unless advised to the contrary.

IMPORTANT REMINDER: Maintenance fees are due in utility patents issuing on applications filed on or after Dec. 12, 1980. It is patentee's responsibility to ensure timely payment of maintenance fees when due. More information is available at www.uspto.gov/PatentMaintenanceFees.



**PART B - FEE(S) TRANSMITTAL**

**Complete and send this form, together with applicable fee(s), to: Mail Mail Stop ISSUE FEE  
 Commissioner for Patents  
 P.O. Box 1450  
 Alexandria, Virginia 22313-1450  
 or Fax (571)-273-2885**

**INSTRUCTIONS:** This form should be used for transmitting the ISSUE FEE and PUBLICATION FEE (if required). Blocks 1 through 5 should be completed where appropriate. All further correspondence including the Patent, advance orders and notification of maintenance fees will be mailed to the current correspondence address as indicated unless corrected below or directed otherwise in Block 1, by (a) specifying a new correspondence address; and/or (b) indicating a separate "FEE ADDRESS" for maintenance fee notifications.

CURRENT CORRESPONDENCE ADDRESS (Note: Use Block 1 for any change of address)

59911                      7590                      12/13/2017  
**MITCH HARRIS, LLC - GENERAL**  
 P.O. BOX 1269  
 ATHENS, GA 30603-1269

Note: A certificate of mailing can only be used for domestic mailings of the Fee(s) Transmittal. This certificate cannot be used for any other accompanying papers. Each additional paper, such as an assignment or formal drawing, must have its own certificate of mailing or transmission.

**Certificate of Mailing or Transmission**

I hereby certify that this Fee(s) Transmittal is being deposited with the United States Postal Service with sufficient postage for first class mail in an envelope addressed to the Mail Stop ISSUE FEE address above, or being facsimile transmitted to the USPTO (571) 273-2885, on the date indicated below.

(Depositor's name)
(Signature)
(Date)

APPLICATION NO.	FILING DATE	FIRST NAMED INVENTOR	ATTORNEY DOCKET NO.	CONFIRMATION NO.
15/717,138	09/27/2017	Mark Jefferson Reed	TX1000-C7	3036

TITLE OF INVENTION: INTERNET QUERIED DIRECTIONAL NAVIGATION SYSTEM WITH MOBILE AND FIXED ORIGINATING LOCATION DETERMINATION

APPLN. TYPE	ENTITY STATUS	ISSUE FEE DUE	PUBLICATION FEE DUE	PREV. PAID ISSUE FEE	TOTAL FEE(S) DUE	DATE DUE
nonprovisional	SMALL	\$480	\$0	\$0	\$480	03/13/2018

EXAMINER	ART UNIT	CLASS-SUBCLASS
PATEL, AJIT	2644	455-456300

1. Change of correspondence address or indication of "Fee Address" (37 CFR 1.363). <input type="checkbox"/> Change of correspondence address (or Change of Correspondence Address Form PTO/SB/122) attached. <input type="checkbox"/> "Fee Address" indication (or "Fee Address" Indication form PTO/SB/47; Rev 03-02 or more recent) attached. <b>Use of a Customer Number is required.</b>	2. For printing on the patent front page, list (1) The names of up to 3 registered patent attorneys or agents OR, alternatively, 1 _____ (2) The name of a single firm (having as a member a registered attorney or agent) and the names of up to 2 registered patent attorneys or agents. If no name is listed, no name will be printed. 2 _____ 3 _____
--	--

3. ASSIGNEE NAME AND RESIDENCE DATA TO BE PRINTED ON THE PATENT (print or type)

PLEASE NOTE: Unless an assignee is identified below, no assignee data will appear on the patent. If an assignee is identified below, the document has been filed for recordation as set forth in 37 CFR 3.11. Completion of this form is NOT a substitute for filing an assignment.

(A) NAME OF ASSIGNEE \_\_\_\_\_ (B) RESIDENCE: (CITY and STATE OR COUNTRY) \_\_\_\_\_

Please check the appropriate assignee category or categories (will not be printed on the patent) :  Individual  Corporation or other private group entity  Government

4a. The following fee(s) are submitted: <input type="checkbox"/> Issue Fee <input type="checkbox"/> Publication Fee (No small entity discount permitted) <input type="checkbox"/> Advance Order - # of Copies _____	4b. Payment of Fee(s): ( <b>Please first reapply any previously paid issue fee shown above</b> ) <input type="checkbox"/> A check is enclosed. <input type="checkbox"/> Payment by credit card. Form PTO-2038 is attached. <input type="checkbox"/> The director is hereby authorized to charge the required fee(s), any deficiency, or credits any overpayment, to Deposit Account Number _____ (enclose an extra copy of this form).
--	---

5. **Change in Entity Status** (from status indicated above)

Applicant certifying micro entity status. See 37 CFR 1.29 **NOTE:** Absent a valid certification of Micro Entity Status (see forms PTO/SB/15A and 15B), issue fee payment in the micro entity amount will not be accepted at the risk of application abandonment.

Applicant asserting small entity status. See 37 CFR 1.27 **NOTE:** If the application was previously under micro entity status, checking this box will be taken to be a notification of loss of entitlement to micro entity status.

Applicant changing to regular undiscounted fee status. **NOTE:** Checking this box will be taken to be a notification of loss of entitlement to small or micro entity status, as applicable.

**NOTE:** This form must be signed in accordance with 37 CFR 1.31 and 1.33. See 37 CFR 1.4 for signature requirements and certifications.

Authorized Signature _____	Date _____
Typed or printed name _____	Registration No. _____



UNITED STATES PATENT AND TRADEMARK OFFICE

UNITED STATES DEPARTMENT OF COMMERCE
United States Patent and Trademark Office
Address: COMMISSIONER FOR PATENTS
P.O. Box 1450
Alexandria, Virginia 22313-1450
www.uspto.gov

Table with columns: APPLICATION NO., FILING DATE, FIRST NAMED INVENTOR, ATTORNEY DOCKET NO., CONFIRMATION NO., EXAMINER, ART UNIT, PAPER NUMBER. Includes application details for Mark Jefferson Reed and Mitch Harris, LLC.

Determination of Patent Term Adjustment under 35 U.S.C. 154 (b)
(Applications filed on or after May 29, 2000)

The Office has discontinued providing a Patent Term Adjustment (PTA) calculation with the Notice of Allowance.

Section 1(h)(2) of the AIA Technical Corrections Act amended 35 U.S.C. 154(b)(3)(B)(i) to eliminate the requirement that the Office provide a patent term adjustment determination with the notice of allowance. See Revisions to Patent Term Adjustment, 78 Fed. Reg. 19416, 19417 (Apr. 1, 2013). Therefore, the Office is no longer providing an initial patent term adjustment determination with the notice of allowance. The Office will continue to provide a patent term adjustment determination with the Issue Notification Letter that is mailed to applicant approximately three weeks prior to the issue date of the patent, and will include the patent term adjustment on the patent. Any request for reconsideration of the patent term adjustment determination (or reinstatement of patent term adjustment) should follow the process outlined in 37 CFR 1.705.

Any questions regarding the Patent Term Extension or Adjustment determination should be directed to the Office of Patent Legal Administration at (571)-272-7702. Questions relating to issue and publication fee payments should be directed to the Customer Service Center of the Office of Patent Publication at 1-(888)-786-0101 or (571)-272-4200.

## OMB Clearance and PRA Burden Statement for PTOL-85 Part B

The Paperwork Reduction Act (PRA) of 1995 requires Federal agencies to obtain Office of Management and Budget approval before requesting most types of information from the public. When OMB approves an agency request to collect information from the public, OMB (i) provides a valid OMB Control Number and expiration date for the agency to display on the instrument that will be used to collect the information and (ii) requires the agency to inform the public about the OMB Control Number's legal significance in accordance with 5 CFR 1320.5(b).

The information collected by PTOL-85 Part B is required by 37 CFR 1.311. The information is required to obtain or retain a benefit by the public which is to file (and by the USPTO to process) an application. Confidentiality is governed by 35 U.S.C. 122 and 37 CFR 1.14. This collection is estimated to take 12 minutes to complete, including gathering, preparing, and submitting the completed application form to the USPTO. Time will vary depending upon the individual case. Any comments on the amount of time you require to complete this form and/or suggestions for reducing this burden, should be sent to the Chief Information Officer, U.S. Patent and Trademark Office, U.S. Department of Commerce, P.O. Box 1450, Alexandria, Virginia 22313-1450. DO NOT SEND FEES OR COMPLETED FORMS TO THIS ADDRESS. SEND TO: Commissioner for Patents, P.O. Box 1450, Alexandria, Virginia 22313-1450. Under the Paperwork Reduction Act of 1995, no persons are required to respond to a collection of information unless it displays a valid OMB control number.

### Privacy Act Statement

**The Privacy Act of 1974 (P.L. 93-579)** requires that you be given certain information in connection with your submission of the attached form related to a patent application or patent. Accordingly, pursuant to the requirements of the Act, please be advised that: (1) the general authority for the collection of this information is 35 U.S.C. 2(b)(2); (2) furnishing of the information solicited is voluntary; and (3) the principal purpose for which the information is used by the U.S. Patent and Trademark Office is to process and/or examine your submission related to a patent application or patent. If you do not furnish the requested information, the U.S. Patent and Trademark Office may not be able to process and/or examine your submission, which may result in termination of proceedings or abandonment of the application or expiration of the patent.

The information provided by you in this form will be subject to the following routine uses:

1. The information on this form will be treated confidentially to the extent allowed under the Freedom of Information Act (5 U.S.C. 552) and the Privacy Act (5 U.S.C. 552a). Records from this system of records may be disclosed to the Department of Justice to determine whether disclosure of these records is required by the Freedom of Information Act.
2. A record from this system of records may be disclosed, as a routine use, in the course of presenting evidence to a court, magistrate, or administrative tribunal, including disclosures to opposing counsel in the course of settlement negotiations.
3. A record in this system of records may be disclosed, as a routine use, to a Member of Congress submitting a request involving an individual, to whom the record pertains, when the individual has requested assistance from the Member with respect to the subject matter of the record.
4. A record in this system of records may be disclosed, as a routine use, to a contractor of the Agency having need for the information in order to perform a contract. Recipients of information shall be required to comply with the requirements of the Privacy Act of 1974, as amended, pursuant to 5 U.S.C. 552a(m).
5. A record related to an International Application filed under the Patent Cooperation Treaty in this system of records may be disclosed, as a routine use, to the International Bureau of the World Intellectual Property Organization, pursuant to the Patent Cooperation Treaty.
6. A record in this system of records may be disclosed, as a routine use, to another federal agency for purposes of National Security review (35 U.S.C. 181) and for review pursuant to the Atomic Energy Act (42 U.S.C. 218(c)).
7. A record from this system of records may be disclosed, as a routine use, to the Administrator, General Services, or his/her designee, during an inspection of records conducted by GSA as part of that agency's responsibility to recommend improvements in records management practices and programs, under authority of 44 U.S.C. 2904 and 2906. Such disclosure shall be made in accordance with the GSA regulations governing inspection of records for this purpose, and any other relevant (i.e., GSA or Commerce) directive. Such disclosure shall not be used to make determinations about individuals.
8. A record from this system of records may be disclosed, as a routine use, to the public after either publication of the application pursuant to 35 U.S.C. 122(b) or issuance of a patent pursuant to 35 U.S.C. 151. Further, a record may be disclosed, subject to the limitations of 37 CFR 1.14, as a routine use, to the public if the record was filed in an application which became abandoned or in which the proceedings were terminated and which application is referenced by either a published application, an application open to public inspection or an issued patent.
9. A record from this system of records may be disclosed, as a routine use, to a Federal, State, or local law enforcement agency, if the USPTO becomes aware of a violation or potential violation of law or regulation.

<b>Notice of Allowability</b>	<b>Application No.</b> 15/717,138	<b>Applicant(s)</b> REED ET AL.	
	<b>Examiner</b> AJIT PATEL	<b>Art Unit</b> 2644	<b>AIA (First Inventor to File) Status</b> No

**-- The MAILING DATE of this communication appears on the cover sheet with the correspondence address--**

All claims being allowable, PROSECUTION ON THE MERITS IS (OR REMAINS) CLOSED in this application. If not included herewith (or previously mailed), a Notice of Allowance (PTOL-85) or other appropriate communication will be mailed in due course. **THIS NOTICE OF ALLOWABILITY IS NOT A GRANT OF PATENT RIGHTS.** This application is subject to withdrawal from issue at the initiative of the Office or upon petition by the applicant. See 37 CFR 1.313 and MPEP 1308.

1.  This communication is responsive to 9/27/17.  
 A declaration(s)/affidavit(s) under **37 CFR 1.130(b)** was/were filed on \_\_\_\_\_.
2.  An election was made by the applicant in response to a restriction requirement set forth during the interview on \_\_\_\_\_; the restriction requirement and election have been incorporated into this action.
3.  The allowed claim(s) is/are 1-30. As a result of the allowed claim(s), you may be eligible to benefit from the **Patent Prosecution Highway** program at a participating intellectual property office for the corresponding application. For more information, please see [http://www.uspto.gov/patents/init\\_events/pph/index.jsp](http://www.uspto.gov/patents/init_events/pph/index.jsp) or send an inquiry to PPHfeedback@uspto.gov.
4.  Acknowledgment is made of a claim for foreign priority under 35 U.S.C. § 119(a)-(d) or (f).

**Certified copies:**

- a)  All    b)  Some    \*c)  None of the:
1.  Certified copies of the priority documents have been received.
  2.  Certified copies of the priority documents have been received in Application No. \_\_\_\_\_.
  3.  Copies of the certified copies of the priority documents have been received in this national stage application from the International Bureau (PCT Rule 17.2(a)).

\* Certified copies not received: \_\_\_\_\_.

Applicant has THREE MONTHS FROM THE "MAILING DATE" of this communication to file a reply complying with the requirements noted below. Failure to timely comply will result in ABANDONMENT of this application. **THIS THREE-MONTH PERIOD IS NOT EXTENDABLE.**

5.  CORRECTED DRAWINGS ( as "replacement sheets") must be submitted.  
 including changes required by the attached Examiner's Amendment / Comment or in the Office action of Paper No./Mail Date \_\_\_\_\_.  
**Identifying indicia such as the application number (see 37 CFR 1.84(c)) should be written on the drawings in the front (not the back) of each sheet. Replacement sheet(s) should be labeled as such in the header according to 37 CFR 1.121(d).**
6.  DEPOSIT OF and/or INFORMATION about the deposit of BIOLOGICAL MATERIAL must be submitted. Note the attached Examiner's comment regarding REQUIREMENT FOR THE DEPOSIT OF BIOLOGICAL MATERIAL.

**Attachment(s)**

- |   |  |
|---|--|
| <ol style="list-style-type: none"> <li>1. <input checked="" type="checkbox"/> Notice of References Cited (PTO-892)</li> <li>2. <input checked="" type="checkbox"/> Information Disclosure Statements (PTO/SB/08),<br/>Paper No./Mail Date _____</li> <li>3. <input type="checkbox"/> Examiner's Comment Regarding Requirement for Deposit<br/>of Biological Material</li> <li>4. <input type="checkbox"/> Interview Summary (PTO-413),<br/>Paper No./Mail Date _____</li> </ol> | <ol style="list-style-type: none"> <li>5. <input type="checkbox"/> Examiner's Amendment/Comment</li> <li>6. <input checked="" type="checkbox"/> Examiner's Statement of Reasons for Allowance</li> <li>7. <input type="checkbox"/> Other _____.</li> </ol> |
|---|--|

/AJIT PATEL/  
Primary Examiner, Art Unit 2644

1. The present application is being examined under the pre-AIA first to invent provisions.

***Allowable Subject Matter***

2. The following is an examiner's statement of reasons for allowance: The prior art of Leblanc et al and Lau et al fail to disclose

1. A method of providing navigation assistance to a user of a communications device, the method comprising: receiving, by a directional assistance service, an Internet query initiated at the communications device and directed via the Internet to initiate a request for navigational assistance to a destination; responsive to receiving the Internet query, determining whether or not the communications device is a mobile wireless communications device; responsive to determining that the communications device is the mobile wireless communications device, the directional assistance service determining and using a present location of the mobile wireless communications device as a location of the communications device; responsive to determining that the communications device is not the mobile wireless communications device, obtaining a fixed location associated with the communications device to determine the location of the communications device; and the directional assistance service providing navigation information to the communications device in response to the Internet query, wherein the navigation provides directions for proceeding from the location of the communications device to a location of the destination.

15. A mobile wireless communications network, comprising: multiple radio-frequency transceivers and associated multiple antennas to which the associated radio-frequency transceivers are coupled, wherein the multiple radio-frequency transceivers are configured for radio-frequency communication with one or more mobile wireless communications devices; and a directional assistance network coupled to the multiple radio-frequency transceivers, wherein the directional assistance network receives an Internet query initiated at a communications device and directed via the Internet to initiate a request for navigational assistance to a destination and responsive to receiving the Internet query, determines whether or not the communications device is a one of the one or more mobile wireless communications devices, and responsive to determining that the communications device is a one of the one or more mobile wireless communications devices, determines and uses a present location of the communication device as a location of the communications device, wherein the directional assistance network, responsive to determining that the communications device is not one of the one or more mobile wireless communications devices, obtains a fixed location associated with the communications device to determine the location of the communications device, and wherein the directional assistance network provides navigation information to the communications device in response to the Internet query, and wherein the navigation information provides directions for proceeding from the location of the communications device to a location of the destination.

29. A method of providing navigation assistance to a user of a communications device, the method comprising: a directional assistance network prompting the user of

Art Unit: 2644

the communications device to provide an option for selection of suggested nearby businesses as a destination; responsive to the user selecting the option for selection of suggested nearby businesses, the directional assistance network suggesting one or more nearby businesses; responsive to a user input selecting a selected one of the suggested nearby businesses, the communications device sending an Internet query including an identifier of the selected one of the suggested nearby businesses. the directional assistance network receiving the Internet query, wherein the directional assistance network determines a location of the destination from the identifier of the selected one of the suggested nearby businesses; responsive to receiving the Internet query, determining whether or not the communications device is a mobile wireless communications device; responsive to determining that the communications device is a mobile wireless communications device, the directional assistance network determining and using a present location of the mobile wireless communications device as a location of the communications device; responsive to determining that the communications device is not the mobile wireless communications device, obtaining a fixed location associated with the communications device to determine the location of the communications device by querying a public service telephone network (PSTN) to retrieve the fixed location of the communications device from a database; the directional assistance network initiating locating the mobile wireless communications device by sending a query to a switch or base station controller of a wireless network; and building an internal database storing the present location of the mobile wireless communications device with results of the query and using the stored location as the location of the

Art Unit: 2644

communications device; and the directional assistance network providing navigation information to the communications device in response to the query, wherein the navigation provides directions for proceeding from the location of the communications device to the location of the destination.

30. A mobile wireless communications network, comprising: multiple radio-frequency transceivers and associated multiple antennas to which the associated radio-frequency transceivers are coupled, wherein the multiple radio-frequency transceivers are configured for radio-frequency communication with one or more mobile wireless communications devices; and a directional assistance network coupled to the multiple radio-frequency transceivers, wherein the directional assistance network prompts a user of the communications device to provide an option for selection of suggested nearby businesses as a destination, and responsive to the user selecting the option for selection of suggested nearby businesses, the directional assistance network suggesting one or more nearby businesses, wherein the directional assistance network receives an Internet query initiated at the communications device and directed via the Internet to initiate a request for navigational assistance to a selected one of the one or more nearby businesses as the destination and responsive to receiving the Internet query, determines whether or not the communications device is one of the one or more mobile wireless communications devices, and responsive to determining that the communications device is one of the one or more mobile wireless communications devices determines and uses a present location of the one of the communications device as a location of the communications device by initiating locating the



Art Unit: 2644

communications device by sending a query to a switch or base station controller of the wireless network, building an internal database storing the present location of the communications device with results of the query and using the stored location as the location of the communications device, and responsive to determining that the communications device is not one of the one or more mobile wireless communications devices, obtains a fixed location associated with the communications device retrieving the fixed location from a database by querying a public service telephone network (PSTN) to determine the location of the communications device, and wherein the directional assistance network provides navigation information to the communications device in response to the query, wherein the navigation information provides directions for proceeding from the location of the communications device to a location of the destination.

Any comments considered necessary by applicant must be submitted no later than the payment of the issue fee and, to avoid processing delays, should preferably accompany the issue fee. Such submissions should be clearly labeled "Comments on Statement of Reasons for Allowance."

3. Any inquiry concerning this communication or earlier communications from the examiner should be directed to AJIT PATEL whose telephone number is (571)272-3140. The examiner can normally be reached on MON-FRI.

If attempts to reach the examiner by telephone are unsuccessful, the examiner's supervisor, Kathy Wang-Hurst can be reached on 571-270-5371. The fax phone number for the organization where this application or proceeding is assigned is 571-273-8300.

Information regarding the status of an application may be obtained from the Patent Application Information Retrieval (PAIR) system. Status information for published applications may be obtained from either Private PAIR or Public PAIR. Status information for unpublished applications is available through Private PAIR only. For more information about the PAIR system, see <http://pair-direct.uspto.gov>. Should you have questions on access to the Private PAIR system, contact the Electronic Business Center (EBC) at 866-217-9197 (toll-free). If you would like assistance from a USPTO Customer Service Representative or access to the automated information system, call 800-786-9199 (IN USA OR CANADA) or 571-272-1000.

/AJIT PATEL/  
Primary Examiner, Art Unit 2644

<b>Notice of References Cited</b>	Application/Control No. 15/717,138	Applicant(s)/Patent Under Reexamination REED ET AL.	
	Examiner AJIT PATEL	Art Unit 2644	Page 1 of 1

**U.S. PATENT DOCUMENTS**

*	Document Number Country Code-Number-Kind Code	Date MM-YYYY	Name	CPC Classification	US Classification
*	A US-6,236,365 B1	05-2001	LeBlanc; Frederick W.	G01C21/206	342/450
*	B US-2002/0168986 A1	11-2002	Lau, David	G01C21/3608	455/456.1
*	C US-6,757,718 B1	06-2004	Halverson; Christine	G06F9/465	704/257
*	D US-2001/0046884 A1	11-2001	Yoshioka, Kazunori	G01C21/26	455/564
*	E US-2001/0044310 A1	11-2001	LINCKE, SCOTT	G06F17/3087	455/456.2
*	F US-6,487,495 B1	11-2002	Gale; William	G01C21/343	701/10
*	G US-6,654,683 B2	11-2003	Jin; HaiPing	G01C21/3655	701/431
	H US-				
	I US-				
	J US-				
	K US-				
	L US-				
	M US-				

**FOREIGN PATENT DOCUMENTS**

*	Document Number Country Code-Number-Kind Code	Date MM-YYYY	Country	Name	CPC Classification
	N				
	O				
	P				
	Q				
	R				
	S				
	T				

**NON-PATENT DOCUMENTS**

*	Document Number Country Code-Number-Kind Code	Date MM-YYYY	Country	Name	CPC Classification
	Include as applicable: Author, Title Date, Publisher, Edition or Volume, Pertinent Pages)				
	U				
	V				
	W				
	X				

\*A copy of this reference is not being furnished with this Office action. (See MPEP § 707.05(a).)  
Dates in MM-YYYY format are publication dates. Classifications may be US or foreign.

<b>Search Notes</b>  	<b>Application/Control No.</b>  15717138	<b>Applicant(s)/Patent Under Reexamination</b>  REED ET AL.
	<b>Examiner</b>  AJIT PATEL	<b>Art Unit</b>  2644

CPC- SEARCHED		
Symbol	Date	Examiner
H04W4/023;H04B17/318;G01S5/0252;H04W4/028	12/10/2017	AP
(H04W\$/\$.CPC.	12/10/2017	AP
(H04B\$/\$.CPC.	12/10/2017	AP
(G01S\$/\$.CPC.	12/10/2017	AP

CPC COMBINATION SETS - SEARCHED		
Symbol	Date	Examiner

US CLASSIFICATION SEARCHED			
Class	Subclass	Date	Examiner

\* See search history printout included with this form or the SEARCH NOTES box below to determine the scope of the search.

SEARCH NOTES		
Search Notes	Date	Examiner
Inventor name search	12/10/2017	AP
EAST	12/10/2017	AP

INTERFERENCE SEARCH			
US Class/ CPC Symbol	US Subclass / CPC Group	Date	Examiner
	See EAST for interference search	12/10/2017	AP

--	--

Substitute for form 1449/PTO  <b>INFORMATION DISCLOSURE STATEMENT BY APPLICANT</b>	<b>Complete if Known</b>	
	Application Number	--Unknown--
	Filing Date	--Submitted herewith-- 9/27/17
	First Named Inventor	Reed
	Examiner Name	-- Unknown --
	Art Unit	-- Unknown --
	Attorney Docket No.	TX1000-C7

Examiner Initials	Document Number	Publication Date MM-DD-YYYY	Name of Patentee or Applicant of Cited Document	Pages, Columns, Lines, Where Relevant Passages or Relevant Figures Appear
	US-20170195847-A1	07-06-2017	Reed, et al.	
	US-9,642,024-B2	05-02-2017	Reed, et al.	
	US-20160227510-A1	04-15-2016	Reed, et al.	
	US-20150312882-A1	10-29-2015	Reed, et al.	
	US-8,977,284-B2	03-10-2015	Reed	
	US-20030134648-A1	07-17-2003	Reed	
	US-6,845,246-B1	01-18-2005	Steer	
	US-6,931,256-B2	08-16-2005	Mandyam	
	US-6,334,047-B1	12-25-2001	Andersson, et al.	
	US-7,689,240-B2	03-30-2010	Anderson	
	US-7,120,392-B2	10-10-2006	Chu, et al.	
	US-6,157,838	12-05-2000	Di Huo, et al.	
	US-7,574,230-B1	08-11-2009	Oh, et al.	
	US-6,298,306-B1	10-02-2001	Suarez, et al.	
	US-7,634,266-B2	12-15-2009	McDougall, et al.	
	US-6,751,443-B2	06-15-2004	Haymes, et al.	
	US-7,333,820-B2	02-19-2008	Sheha, et al.	
	US-8,218,507-B2	07-10-2012	Palmer, et al.	
	US-7,853,267-B2	12-14-2010	Jensen	
	US-6,901,264	05-31-2005	Myr	
	US-3,419,865	12-31-1968	Chisholm	
	US-4,494,119	01-15-1985	Wimbush	
	US-5,873,040	02-16-1999	Dunn, et al.	
	US-5,930,515	07-27-1999	Ducharme, et al.	
	US-6,308,073-B1	10-23-2001	Petty, et al.	
	US-7,366,522-B2	04-29-2008	Thomas	
	US-6,799,049-B1	09-28-2004	Zellner, et al.	
	US-5,479,482	12-26-1995	Grimes	
	US-6,603,977-B1	08-05-2003	Walsh, et al.	
	US-6,816,720-B2	11-09-2004	Hussain, et al.	
	US-6,839,552-B1	01-04-2005	Martin	
	US-4,818,998	04-04-1989	Apsell, et al.	

Examiner: /AJIT PATEL/

Date Considered: 12/09/2017

EXAMINER: Initial if reference considered, whether or not citation is in conformance with MPEP 609; Draw line through citation if not in conformance and not considered. Include copy of this form with next communication to applicant.

ALL REFERENCES CONSIDERED EXCEPT WHERE LINED THROUGH. /A.P/

Under the Paperwork Reduction Act of 1995, no persons are required to respond to a collection of information unless it displays a valid OMB control number.

Substitute for form 1449/PTO  <b>INFORMATION DISCLOSURE STATEMENT BY APPLICANT</b>	<b>Complete if Known</b>	
	Application Number	--Unknown--
	Filing Date	--Submitted herewith-- 9/27/17
	First Named Inventor	Reed
	Examiner Name	-- Unknown --
	Art Unit	-- Unknown --
	Attorney Docket No.	TX1000-C7

Examiner Initials	Document Number	Publication Date MM-DD-YYYY	Name of Patentee or Applicant of Cited Document	Pages, Columns, Lines, Where Relevant Passages or Relevant Figures Appear
	US-4,908,629	03-13-1990	Apsell, et al.	
	US-4,891,650	01-02-1990	Sheffer	
	US-6,249,252-B1	06-19-2001	Dupray	
	US-6,249,680-B1	06-19-2001	Wax, et al.	
	US-6,167,275	12-26-2000	Oros, et al.	
	US-6,091,956	07-18-2000	Hollenberg	
	US-6,633,761-B1	10-14-2003	Singhal, et al.	
	US-5,561,704	10-01-1996	Salimando	
	US-5,694,335	12-02-1997	Hollenberg	
	US-6,150,961	11-21-2000	Alewine, et al.	
	US-20150309295-A1	10-29-2015	Cocker, et al.	
	US-7,082,365-B2	07-25-2006	Sheha, et al.	
	US-20020052786-A1	05-02-2002	Kim, et al.	
	US-5,933,100	08-03-1999	Golding	
	US-6,052,598	04-18-2000	Rudrapatna, et al.	
	US-6,362,783-B1	03-26-2002	Sigiura, et al.	
	US-6,505,114-B2	01-07-2003	Luciani	
	US-6,314,365-B1	11-06-2001	Smith	
	US-6,490,521-B2	12-03-2002	Wiener	
	US-6,401,035-B2	06-04-2002	Jin	
	US-6,654,683-B2	11-25-2003	Jin, et al.	
	US-7,389,179-B2	06-17-2008	Jin, et al.	
	US-6,151,505	11-21-2000	Larkins, et al.	
	US-6,292,743-B1	09-18-2001	Pu, et al.	
	US-6,111,539	08-29-2000	Mannings, et al.	
	US-5,504,482	04-02-1996	Schreder	
	US-5,712,899	01-27-1998	Pace, II	
	US-6,295,502-B1	09-25-2001	Hancock, et al.	
	US-6,542,816-B1	04-01-2003	Ito, et al.	
	US-5,959,577	09-28-1999	Fan, et al.	
	US-6,088,594	07-11-2000	Kingdon, et al.	
	US-6,677,894-B2	01-13-2004	Sheynblat, et al.	

Examiner: /AJIT PATEL/ Date Considered: 12/09/2017

EXAMINER: Initial if reference considered, whether or not citation is in conformance with MPEP 609; Draw line through citation if not in conformance and not considered. Include copy of this form with next communication to applicant.

ALL REFERENCES CONSIDERED EXCEPT WHERE LINED THROUGH. /A.P/

Substitute for form 1449/PTO  <b>INFORMATION DISCLOSURE STATEMENT BY APPLICANT</b>	<b>Complete if Known</b>	
	Application Number	--Unknown--
	Filing Date	--Submitted herewith-- 9/27/17
	First Named Inventor	Reed
	Examiner Name	-- Unknown --
	Art Unit	-- Unknown --
	Attorney Docket No.	TX1000-C7

Examiner Initials	Document Number	Publication Date MM-DD-YYYY	Name of Patentee or Applicant of Cited Document	Pages, Columns, Lines, Where Relevant Passages or Relevant Figures Appear
	US-6,243,030-B1	06-05-2001	Levine	
	US-6,442,394-B1	08-27-2002	Valentine, et al.	
	US-6,950,745-B2	09-27-2005	Agnew, et al.	
	US-6,853,915-B2	02-08-2005	Hubschneider, et al.	
	US-5,911,773	06-15-1999	Mutsuga, et al.	
	US-6,163,751	12-19-2000	Van Roekel	
	US-6,278,941-B1	08-21-2001	Yokoyama	
	US-6,341,255-B1	01-22-2002	Lapidot	
	US-7,260,473-B2	08-21-2007	Abe, et al.	
	US-6,421,607-B1	07-16-2002	Gee, et al.	
	US-7,117,085-B2	10-03-2006	Buecher, et al.	
	US-6,317,684-B1	11-13-2001	Roeseler, et al.	
	US-6,484,093-B1	11-19-2002	Ito, et al.	
	US-6,282,491-B1	08-28-2001	Bochmann, et al.	
	US-5,543,789	08-06-1996	Behr, et al.	
	US-5,839,086	11-17-1998	Hirano	
	US-6,336,073-B1	01-01-2002	Ihara, et al.	
	US-6,725,155-B1	04-20-2004	Takahashi, et al.	
	US-6,662,105-B1	12-09-2003	Tada, et al.	
	US-6,847,889-B2	01-25-2005	Park, et al.	
	US-6,614,363-B1	09-02-2003	Behr, et al.	
	US-6,084,955	07-04-2000	Key, et al.	
	US-6,266,514-B1	07-24-2001	O'Donnell	
	US-7,280,803-B2	10-09-2007	Nelson	
	US-6,782,256-B2	08-24-2004	Engholm, et al.	
	US-6,317,605-B1	11-13-2001	Sakuma	
	US-7,333,794-B2	02-19-2008	Zappala	
	US-6,985,839-B1	01-10-2006	Motamedi, et al.	
	US-7,116,990-B2	10-03-2006	Maanoja	
	US-20050043036-A1	02-24-2005	Ioppe, et al.	
	US-7,203,503-B2	04-10-2007	Cedervall, et al.	
	US-6,907,252-B2	06-14-2005	Papadias, et al.	

Examiner: /AJIT PATEL/ Date Considered: 12/09/2017

EXAMINER: Initial if reference considered, whether or not citation is in conformance with MPEP 609; Draw line through citation if not in conformance and not considered. Include copy of this form with next communication to applicant.

ALL REFERENCES CONSIDERED EXCEPT WHERE LINED THROUGH. /A.P/

Substitute for form 1449/PTO  <b>INFORMATION DISCLOSURE STATEMENT BY APPLICANT</b>	<b>Complete if Known</b>	
	Application Number	--Unknown--
	Filing Date	--Submitted herewith-- 9/27/17
	First Named Inventor	Reed
	Examiner Name	-- Unknown --
	Art Unit	-- Unknown --
	Attorney Docket No.	TX1000-C7

Examiner Initials	Document Number	Publication Date MM-DD-YYYY	Name of Patentee or Applicant of Cited Document	Pages, Columns, Lines, Where Relevant Passages or Relevant Figures Appear
	US-7,996,017-B2	08-09-2011	Vanttinen	
	US-7,151,940-B2	12-19-2006	Vanttinen, et al.	
	US-6,526,283-B1	02-25-2003	Jang	
	US-7,574,222-B2	08-11-2009	Sawada, et al.	
	US-6,721,542-B1	04-13-2004	Anttila, et al.	
	US-7,149,201-B2	12-12-2006	Hunzinger	
	US-7,024,187-B2	04-04-2006	Moles, et al.	
	US-6,298,233-B1	10-02-2001	Souissi, et al.	
	US-6,925,300-B2	08-02-2005	Horne	
	US-6,073,075	06-06-2000	Kondou	
	US-6,941,220-B2	09-06-2005	Le, et al.	
	US-7,162,367-B2	01-09-2007	Lin, et al.	
	US-20030199260-A1	10-23-2003	Casey, et al.	
	US-20040246147-A1	12-09-2004	Von Grabe	
	US-7,164,921-B2	01-16-2007	Owens, et al.	
	US-6,456,854-B1	09-24-2002	Chern, et al.	
	US-6,944,447-B2	09-13-2005	Portman, et al.	
	US-20020002504-A1	01-03-2002	Engel, et al.	
	US-5,835,061	11-10-1998	Stewart	
	US-6,650,902-B1	11-18-2003	Richton	
	US-6,836,667-B1	12-28-2004	Smith, Jr.	
	US-7,024,205-B1	04-04-2006	Hose	
	US-7,076,244-B2	07-11-2006	Lazaridis, et al.	
	US-20030004743-A1	01-02-2003	Callegari	
	US-20020161633-A1	10-31-2002	Jacob, et al.	
	US-7,103,368-B2	09-05-2006	Teshima	
	US-7,813,741-B2	10-12-2010	Hendrey, et al.	
	US-20020091568-A1	07-11-2002	Kraft, et al.	
	US-6,798,358-B2	09-28-2004	Joyce, et al.	
	US-20020111154-A1	08-15-2002	Eldering, et al.	
	US-7,089,264-B1	08-08-2006	Guido, et al.	

Examiner: /AJIT PATEL/

Date Considered: 12/09/2017

EXAMINER: Initial if reference considered, whether or not citation is in conformance with MPEP 609; Draw line through citation if not in conformance and not considered. Include copy of this form with next communication to applicant.

ALL REFERENCES CONSIDERED EXCEPT WHERE LINED THROUGH. /A.P/



Substitute for form 1449/PTO  <b>INFORMATION DISCLOSURE STATEMENT BY APPLICANT</b>	<b>Complete if Known</b>	
	Application Number	--Unknown--
	Filing Date	--Submitted herewith-- 9/27/17
	First Named Inventor	Reed
	Examiner Name	-- Unknown --
	Art Unit	-- Unknown --
	Attorney Docket No.	TX1000-C7

Examiner Initials	Document Number	Publication Date MM-DD-YYYY	Name of Patentee or Applicant of Cited Document	Pages, Columns, Lines, Where Relevant Passages or Relevant Figures Appear
	US-6,795,710-B1	09-21-2004	Creemer	
	US-6,157,841	12-05-2000	Bolduc, et al.	
	US-6,580,914-B1	06-17-2003	Smith	
	US-6,014,090	01-11-2000	Rosen, et al.	
	US-6,970,922-B1	11-29-2005	Spector	
	US-6,492,944-B1	12-10-2002	Stilp	
	US-5,519,760	05-21-1996	Borkowski, et al.	
	US-6,321,092-B1	11-20-2001	Fitch, et al.	
	US-6,456,852-B2	09-24-2002	Bar, et al.	
	US-6,317,604-B1	11-13-2001	Kovach, Jr., et al.	
	US-6,952,181-B2	10-04-2005	Karr, et al.	
	US-6,236,365-B1	05-22-2001	LeBlanc, et al.	
	US-6,961,562-B2	11-01-2005	Ross	
	US-7,123,918-B1	10-17-2006	Goodman	
	US-20040093289-A1	05-13-2004	Bodin	
	US-6,557,139-B2	04-29-2003	Bohnke	
	US-6,233,449-B1	05-15-2001	Gliitho, et al.	
	US-7,689,240-B2	03-30-2010	Anderson	
	US-6,839,554-B2	01-04-2005	McDowell, et al.	
	US-20020035605-A1	03-21-2002	McDowell, et al.	
	US-7,546,128-B2	06-09-2009	Smith, et al.	
	US-6,842,620-B2	01-11-2005	Smith, et al.	
	US-5,588,048	12-24-1996	Neville	
	US-20030003900-A1	01-02-2003	Goss, et al.	
	US-7,616,950-B2	11-10-2009	Pearson, et al.	
	US-8,862,106-B2	10-14-2014	Salisbury, et al.	
	US-RE42,937 E	11-15-2011	Want, et al.	
	US-6,847,969-B1	01-25-2005	Mathai, et al.	
	US-6,671,646-B2	12-30-2003	Manegold, et al.	
	US-7,808,369-B2	10-05-2010	Brinton, et al.	

Examiner: /AJIT PATEL/

Date Considered: 12/09/2017

EXAMINER: Initial if reference considered, whether or not citation is in conformance with MPEP 609; Draw line through citation if not in conformance and not considered. Include copy of this form with next communication to applicant.

ALL REFERENCES CONSIDERED EXCEPT WHERE LINED THROUGH. /A.P/

Substitute for form 1449/PTO  <b>INFORMATION DISCLOSURE STATEMENT BY APPLICANT</b>	<b>Complete if Known</b>	
	Application Number	--Unknown--
	Filing Date	--Submitted herewith-- 9/27/17
	First Named Inventor	Reed
	Examiner Name	-- Unknown --
	Art Unit	-- Unknown --
	Attorney Docket No.	TX1000-C7

Examiner Initials	Document Number	Publication Date MM-DD-YYYY	Name of Patentee or Applicant of Cited Document	Pages, Columns, Lines, Where Relevant Passages or Relevant Figures Appear
	US-7,564,375-B2	07-21-2009	Brinton, et al.	
	US-7,362,229-B2	04-22-2008	Brinton, et al.	
	US-7,557,696-B2	07-07-2009	Brinton, et al.	
	US-6,804,626-B2	10-12-2004	Manegold, et al.	
	US-7,117,121-B2	10-03-2006	Brinton, et al.	
	US-5,272,638	12-21-1993	Martin, et al.	
	US-5,465,289	11-07-1995	Kennedy, Jr.	
	US-5,745,865	04-28-1998	Rostoker, et al.	
	US-6,343,290-B1	01-29-2002	Cossins, et al.	
	US-5,844,522	12-01-1998	Sheffer, et al.	
	US-5,987,329	11-16-1999	Yost, et al.	
	US-5,930,717	07-27-1999	Yost, et al.	
	US-6,539,229-B1	03-25-2003	Ali	
	US-6,662,023-B1	12-09-2003	Helle	
	US-6,225,944-B1	05-01-2001	Hayes	
	US-6,246,861-B1	06-12-2001	Messier, et al.	
	US-6,097,336	08-01-2000	Stilp	
	US-6,385,458-B1	05-07-2002	Papadimitriou, et al.	
	US-7,519,372-B2	04-14-2009	MacDonald, et al.	
	US-6,243,588-B1	06-05-2001	Koorapaty, et al.	
	US-5,524,136	06-04-1996	Bar-Noy, et al.	
	US-6,674,403-B2	01-06-2004	Gray, et al.	
	US-20020169539-A1	11-14-2002	Menard, et al.	
	US-5,890,068	03-30-1999	Fattouche, et al.	
	US-6,330,452-B1	12-11-2001	Fattouche, et al.	
	US-7,130,630-B1	10-31-2006	Enzmann, et al.	
	US-7,133,909-B2	11-07-2006	Bahl	
	US-6,236,335-B1	05-22-2001	Goodwin, III	
	US-6,716,101-B1	04-06-2004	Meadows, et al.	
	US-7,525,484-B2	04-28-2009	Dupray, et al.	
	US-8,082,096-B2	12-20-2011	Dupray	

Examiner: /AJIT PATEL/

Date Considered: 12/09/2017

EXAMINER: Initial if reference considered, whether or not citation is in conformance with MPEP 609; Draw line through citation if not in conformance and not considered. Include copy of this form with next communication to applicant.

ALL REFERENCES CONSIDERED EXCEPT WHERE LINED THROUGH. /A.P/

Under the Paperwork Reduction Act of 1995, no persons are required to respond to a collection of information unless it displays a valid OMB control number.

Substitute for form 1449/PTO  <b>INFORMATION DISCLOSURE                  STATEMENT BY APPLICANT</b>	<b>Complete if Known</b>	
	Application Number	--Unknown--
	Filing Date	--Submitted herewith-- 9/27/17
	First Named Inventor	Reed
	Examiner Name	-- Unknown --
	Art Unit	-- Unknown --
	Attorney Docket No.	TX1000-C7

Examiner Initials	Document Number	Publication Date MM-DD-YYYY	Name of Patentee or Applicant of Cited Document	Pages, Columns, Lines, Where Relevant Passages or Relevant Figures Appear
	US-20030146871-A1	08-07-2003	Karr, et al.	
	US-9,134,398-B2	09-15-2015	Dupray, et al.	
	US-7,274,332-B1	09-25-2007	Dupray	
	US-6,466,565-B1	10-15-2002	Wax, et al.	
	US-6,111,538	08-29-2000	Schuchman, et al.	
	US-8,994,591-B2	03-31-2015	Dupray, et al.	
	US-6,204,813-B1	03-20-2001	Wadell, et al.	
	US-6,064,339	05-16-2000	Wax, et al.	
	US-7,020,475-B2	03-28-2006	Bahl, et al.	
	US-6,799,047-B1	09-28-2004	Bahl, et al.	
	US-6,026,304	02-15-2000	Hilsenrath, et al.	
	US-6,393,294-B1	05-21-2002	Perez-Breva, et al.	
	US-6,269,246-B1	07-31-2001	Rao, et al.	
	US-7,164,883-B2	01-16-2007	Rappaport, et al.	
	US-7,664,492-B1	02-16-2010	Lee, et al.	
	US-7,043,254-B2	05-09-2006	Chawla, et al.	
	US6,973,622-B1	12-06-2005	Rappaport, et al.	
	US-6,631,267-B1	10-07-2003	Clarkson, et al.	
	US-6,842,431-B2	01-11-2005	Clarkson, et al.	
	US-7,120,431-B1	10-10-2006	Huo, et al.	
	US-20030054811-A1	03-20-2003	Han, et al.	
	US-7,319,847-B2	01-15-2008	Xanthos, et al.	
	US-6,587,690-B1	07-01-2003	Di Huo, et al.	
	US-7,096,160-B2	08-22-2006	Skidmore, et al.	
	US-20020155816-A1	10-24-2002	Fodor, et al.	
	US-5,920,607	07-06-1999	Berg	
	US-9,528,843-B2	12-27-2016	Pu, et al.	

Examiner: /AJIT PATEL/ Date Considered: 12/09/2017

EXAMINER: Initial if reference considered, whether or not citation is in conformance with MPEP 609; Draw line through citation if not in conformance and not considered. Include copy of this form with next communication to applicant.

ALL REFERENCES CONSIDERED EXCEPT WHERE LINED THROUGH. /A.P/

Under the Paperwork Reduction Act of 1995, no persons are required to respond to a collection of information unless it displays a valid OMB control number.

Substitute for form 1449/PTO  <b>INFORMATION DISCLOSURE                  STATEMENT BY APPLICANT</b>	<b>Complete if Known</b>	
	Application Number	--Unknown--
	Filing Date	--Submitted herewith-- 9/27/17
	First Named Inventor	Reed
	Examiner Name	-- Unknown --
	Art Unit	-- Unknown --
	Attorney Docket No.	TX1000-C7

Examiner Initials	Document Number	Publication Date MM-DD-YYYY	Name of Patentee or Applicant of Cited Document	Pages, Columns, Lines, Where Relevant Passages or Relevant Figures Appear
	US-7,003,264-B2	02-21-2006	Fodor, et al.	
	US-5,799,154	08-25-1998	Kuriyan	
	US-20020152303-A1	10-17-2002	Dispensa	
	US-6,088,588	07-11-2000	Osborne	
	US-6,745,011-B1	06-01-2004	Hendrickson, et al.	
	US-6,751,443-B2	06-15-2004	Haymes, et al.	
	US-6,650,896-B1	11-18-2003	Haymes, et al.	
	US-7,079,945-B1	07-18-2006	Kaplan	
	US-6,374,177-B1	04-16-2002	Lee, et al.	
	US-20020164998-A1	11-07-2002	Younis	
	US-20030065442-A1	04-03-2003	Touney	
	US-6,405,123-B1	06-11-2002	Rennard, et al.	
	US-6,615,131-B1	09-02-2003	Rennard, et al.	
	US-20020115453-A1	08-22-2002	Poulin, et al.	
	US-6,725,156-B2	04-20-2004	Kaplan	
	US-6,947,837-B2	09-20-2005	Fukushima, et al.	
	US-7,149,625-B2	12-12-2006	Mathews, et al.	
	US-20020194498-A1	12-19-2002	Blight, et al.	
	US-6,609,005-B1	08-19-2003	Chern	

FOREIGN PATENT DOCUMENTS				
Examiner Initial	Foreign Patent Document	Publication Date MM-DD-YYYY	Name of Patentee or Applicant of Cited Document	Pages, Columns, Lines, Where Relevant Passages or Relevant Figures Appear
	EP-1,374,481-B1	11-23-2005	Xanthos, et al.	

Examiner: /AJIT PATEL/

Date Considered: 12/09/2017

EXAMINER: Initial if reference considered, whether or not citation is in conformance with MPEP 609; Draw line through citation if not in conformance and not considered. Include copy of this form with next communication to applicant.

ALL REFERENCES CONSIDERED EXCEPT WHERE LINED THROUGH. /A.P/

Under the Paperwork Reduction Act of 1995, no persons are required to respond to a collection of information unless it displays a valid OMB control number.

Substitute for form 1449/PTO  <b>INFORMATION DISCLOSURE                  STATEMENT BY APPLICANT</b>	<b>Complete if Known</b>	
	Application Number	--Unknown--
	Filing Date	--Submitted herewith-- 9/27/17
	First Named Inventor	Reed
	Examiner Name	-- Unknown --
	Art Unit	-- Unknown --
	Attorney Docket No.	TX1000-C7

NON PATENT LITERATURE	
Examiner Initial	Include name of author (in CAPITAL LETTERS), title of the article (when appropriate), title of the item (book, magazine, journal, serial, symposium, catalog, etc.), date, page(s), volume-issue number(s), publisher, city and/or country where published.
	Office Action in 15/297,222 mailed on 12/14/2016, 23 pages (pp. 1-23 in pdf).
	Notice of Allowance in 15/297,222 mailed on 01/12/2017, 6 pages (pp. 1-6 in pdf).
	Office Action in 15/099,960 mailed on 06/28/2016, 15 pages (pp. 1-15 in pdf).
	Notice of Allowance in 15/099,960 mailed on 11/29/2016, 38 pages (pp. 1-38 in pdf).
	Office Action in 14/642,408 mailed on 08/10/2016, 21 pages (pp. 1-21 in pdf).
	Notice of Allowance in 14/642,408 mailed on 09/28/2016, 6 pages (pp. 1-6 in pdf).
	Office Action in 11/505,578 mailed on 07/07/2009, 7 pages (pp. 1-7 in pdf).
	Office Action in 11/505,578 mailed on 05/12/2010, 4 pages (pp. 1-4 in pdf).
	Final Office Action in 11/505,578 mailed on 11/09/2010, 6 pages (pp. 1-6 in pdf).
	Office Action in 11/505,578 mailed on 08/18/2011, 7 pages (pp. 1-7 in pdf).
	Office Action in 11/505,578 mailed on 03/28/2012, 7 pages (pp. 1-7 in pdf).
	Final Office Action in 11/505,578 mailed on 12/12/2012, 8 pages (pp. 1-8 in pdf).
	Notice of Allowance in 11/505,578 mailed on 05/06/2014, 13 pages (pp. 1-13 in pdf).
	Office Action in 10/255,552, mailed on 08/10/05, 12 pages (pp. 1-12 in pdf).
	Final Office Action 10/255,552, mailed on 03/07/06, 19 pages (pp. 1-19 in pdf).
	LUI, et al., "Location Updates and Probabilistic Tracking Algorithms for Mobile Cellular Networks", Fourth International Symposium on Parallel Architectures, Algorithms, and Networks, June 1999, 6 pages (pp. 1-6 in pdf), US.
	KRISHNA, "Performance Issues in Mobile Wireless Networks", Office of Graduate Studies of Texas A&M University, August 1996, 204 pages (pp.1-204 in pdf), US.
	ANONYMOUS, "LADOT'S ADAPTIVE TRAFFIC CONTROL SYSTEM (ATCS)", Presentation at the TRB Workshop on Adaptive Traffic Signal Control Systems, 9 January 2000

Examiner: /AJIT PATEL/

Date Considered: 12/09/2017

EXAMINER: Initial if reference considered, whether or not citation is in conformance with MPEP 609; Draw line through citation if not in conformance and not considered. Include copy of this form with next communication to applicant.

ALL REFERENCES CONSIDERED EXCEPT WHERE LINED THROUGH. /A.P/

**UNITED STATES PATENT AND TRADEMARK OFFICE**

UNITED STATES DEPARTMENT OF COMMERCE  
**United States Patent and Trademark Office**  
 Address: COMMISSIONER FOR PATENTS  
 P.O. Box 1450  
 Alexandria, Virginia 22313-1450  
 www.uspto.gov

**BIB DATA SHEET**
**CONFIRMATION NO. 3036**

SERIAL NUMBER	FILING or 371(c) DATE RULE	CLASS	GROUP ART UNIT	ATTORNEY DOCKET NO. TX1000-C7		
15/717,138	09/27/2017	455	2644			
<b>APPLICANTS</b> Traxcell Technologies, LLC, Plano, TX; <b>INVENTORS</b> Mark Jefferson Reed, Tucson, AZ; Stephen Michael Palik, Redondo Beach, CA; <b>** CONTINUING DATA *****</b> This application is a CON of 15/468,265 03/24/2017 which is a CON of 15/297,222 10/19/2016 PAT 9642024 which is a CON of 14/642,408 03/09/2015 PAT 9510320 which is a CON of 11/505,578 08/17/2006 PAT 8977284 which is a CIP of 10/255,552 09/24/2002 ABN which claims benefit of 60/327,327 10/04/2001 and claims benefit of 60/383,528 05/28/2002 and claims benefit of 60/352,761 01/29/2002 and claims benefit of 60/335,203 10/23/2001 and claims benefit of 60/383,529 05/28/2002 and claims benefit of 60/391,469 06/26/2002 and claims benefit of 60/353,379 01/30/2002 and claims benefit of 60/381,249 05/16/2002 <b>** FOREIGN APPLICATIONS *****</b> <b>** IF REQUIRED, FOREIGN FILING LICENSE GRANTED ** ** SMALL ENTITY **</b> 10/18/2017						
Foreign Priority claimed <input type="checkbox"/> Yes <input checked="" type="checkbox"/> No	35 USC 119(a-d) conditions met <input type="checkbox"/> Yes <input checked="" type="checkbox"/> No	<input type="checkbox"/> Met after Allowance	<b>STATE OR COUNTRY</b> AZ	<b>SHEETS DRAWINGS</b> 90	<b>TOTAL CLAIMS</b> 30	<b>INDEPENDENT CLAIMS</b> 4
Verified and Acknowledged	/AJIT PATEL/ Examiner's Signature	Initials				
<b>ADDRESS</b> MITCH HARRIS, LLC - GENERAL P.O. BOX 1269 ATHENS, GA 30603-1269 UNITED STATES						
<b>TITLE</b> INTERNET QUERIED DIRECTIONAL NAVIGATION SYSTEM WITH MOBILE AND FIXED ORIGINATING LOCATION DETERMINATION						
<b>FILING FEE RECEIVED</b> 1940	FEES: Authority has been given in Paper No. _____ to charge/credit DEPOSIT ACCOUNT No. _____ for following:			<input type="checkbox"/> All Fees <input type="checkbox"/> 1.16 Fees (Filing) <input type="checkbox"/> 1.17 Fees (Processing Ext. of time) <input type="checkbox"/> 1.18 Fees (Issue)		

## EAST Search History

## EAST Search History (Prior Art)

Ref #	Hits	Search Query	DBs	Default Operator	Plurals	Time Stamp
L1	214	(mark near2 reed).in.	US-PGPUB; USPAT	OR	OFF	2017/12/10 09:46
L2	14	(stephen near2 palik).in.	US-PGPUB; USPAT	OR	OFF	2017/12/10 09:46
L3	0	1 and internet same navigation	US-PGPUB; USPAT	OR	OFF	2017/12/10 09:47
L4	0	2 and internet same navigation	US-PGPUB; USPAT	OR	OFF	2017/12/10 09:47
L5	1	"20170195847"	US-PGPUB; USPAT	OR	OFF	2017/12/10 09:48
L6	3	"9642024"	US-PGPUB; USPAT	OR	OFF	2017/12/10 09:48
L7	2	"20160227510"	US-PGPUB; USPAT	OR	OFF	2017/12/10 09:49
L8	3	"20150312882"	US-PGPUB; USPAT	OR	OFF	2017/12/10 09:49
L9	1	"8977282"	US-PGPUB; USPAT	OR	OFF	2017/12/10 09:49
L10	27	((("20030134648") or ("6845246") or ("6931256") or ("6334047") or ("7689240") or ("7120392") or ("6157838") or ("7574230") or ("6298306") or ("7634266") or ("6751443") or ("7333820") or ("8218507") or ("7853267") or ("6901264") or ("3419865") or ("4494119") or ("5873040") or ("5930515") or ("6308073") or ("7366522") or ("6799049") or ("5479482") or ("6603977") or ("6816720") or ("6839552") or ("4818998")).PN.	US-PGPUB; USPAT	OR	OFF	2017/12/10 09:54
L11	32	((("4908629") or ("4891650") or ("6249252") or ("6249680") or ("6167275") or ("6091956") or ("6633761") or ("5561704") or ("5694335") or ("6150961") or ("20150309295") or ("7082365") or ("20020052786") or ("5933100") or ("6052598") or ("6362783") or ("6505114") or ("6314365") or ("6490521") or ("6401035") or ("6654683") or ("7389179") or ("6151505") or ("6292743") or ("6111539") or ("5504482") or ("5712899") or ("6295502") or ("6542816") or ("5959577") or ("6088594") or ("6677894")).PN.	US-PGPUB; USPAT	OR	OFF	2017/12/10 10:11
L12	32	((("6243030") or ("6442394") or	US-PGPUB;	OR	OFF	2017/12/10

		("6950745") or ("6853915") or ("5911773") or ("6163751") or ("6278941") or ("6341255") or ("7260473") or ("6421607") or ("7117085") or ("6317684") or ("6484093") or ("6282491") or ("5543789") or ("5839086") or ("6336073") or ("6725155") or ("6662105") or ("6847889") or ("6614363") or ("6084955") or ("6266514") or ("7280803") or ("6782256") or ("6317605") or ("7333794") or ("6985839") or ("7116990") or ("20050043036") or ("7203503") or ("6907252").PN.	USPAT			10:30
L13	30	("7996017") or ("7151940") or ("6526283") or ("7574222") or ("6721542") or ("7149201") or ("7024187") or ("6298233") or ("6925300") or ("6073075") or ("6941220") or ("7162367") or ("20030199260") or ("20040246147") or ("7164921") or ("6456854") or ("6944447") or ("20020002504") or ("5835061") or ("6650902") or ("6836667") or ("7024205") or ("7076244") or ("20030004743") or ("20020161633") or ("7103368") or ("7813741") or ("20020091568") or ("6798358") or ("2002011154") or ("7089264").PN.	US-PGPUB; USPAT	OR	OFF	2017/12/10 10:42
L14	29	("6795710") or ("6157841") or ("6580914") or ("6014090") or ("6970922") or ("6492944") or ("5519760") or ("6321092") or ("6456852") or ("6317604") or ("6952181") or ("6236365") or ("6961562") or ("7123918") or ("20040093289") or ("6557139") or ("6233449") or ("7689240") or ("6839554") or ("200200365605") or ("7546128") or ("6842620") or ("5588048") or ("20030003900") or ("7616950") or ("8892106") or ("re42937") or ("6847969") or ("6671646") or ("7808369").PN.	US-PGPUB; USPAT	OR	OFF	2017/12/10 10:59
L15	31	("7564375") or ("7362229") or ("7557696") or ("6804626") or ("7117121") or ("5271636") or ("5465289") or ("5745865") or ("6343290") or ("5844522") or ("5987329") or ("5930717") or ("6539229") or ("6662023") or ("6225944") or ("6246861") or ("6097336") or ("6385458") or ("7519372") or ("6243588") or ("5524136") or ("6674403") or ("20020169539") or ("5890068") or ("6330452") or ("7130630") or ("7133909") or ("6236335") or ("6716101") or ("7525484") or ("8082096").PN.	US-PGPUB; USPAT	OR	OFF	2017/12/10 11:05
L16	27	("20030146871") or ("9134398") or	US-PGPUB;	OR	OFF	2017/12/10



		("7274332") or ("5466565") or ("6111538") or ("8994591") or ("6204813") or ("6064339") or ("7020475") or ("6799047") or ("6026304") or ("6393294") or ("6269246") or ("7164883") or ("7664492") or ("7043254") or ("6973622") or ("6631267") or ("6842431") or ("7120431") or ("20030054811") or ("7319847") or ("6587690") or ("7096160") or ("20020155816") or ("5920607") or ("9528843").PN.	USPAT			11:17
L17	19	(("7003264") or ("5799154") or ("20020152303") or ("6088588") or ("6745011") or ("6751443") or ("6650896") or ("7079945") or ("6374177") or ("20020164998") or ("20030065442") or ("6405123") or ("6615131") or ("20020115453") or ("6725156") or ("6947837") or ("7149625") or ("20020194498") or ("6609005")).PN.	US-PGPUB; USPAT	OR	OFF	2017/12/10 11:30
L18	42676	(H04W4/023 or H04B17/318 or G01S5/0252 or H04W4/028).cpc.	US-PGPUB; USPAT; USOCR; FPRS; EPO; JPO; DERWENT; IBM_TDB	OR	ON	2017/12/10 11:36
L19	2207	18 and @ad<"20011023"	US-PGPUB; USPAT; USOCR; FPRS; EPO; JPO; DERWENT; IBM_TDB	OR	ON	2017/12/10 11:37
L20	24	19 and determini\$6 with device with mobile	US-PGPUB; USPAT; USOCR; FPRS; EPO; JPO; DERWENT; IBM_TDB	OR	ON	2017/12/10 11:39
L21	3	19 and (internet or "IP") same query same navigation\$6	US-PGPUB; USPAT; USOCR; FPRS; EPO; JPO; DERWENT; IBM_TDB	OR	ON	2017/12/10 11:42
L22	3	21 and determin\$5 same fix\$5 with (location or position)	US-PGPUB; USPAT; USOCR; FPRS; EPO; JPO; DERWENT; IBM_TDB	OR	ON	2017/12/10 11:44
L23	3	22 and (present or current) with location	US-PGPUB; USPAT; USOCR; FPRS;	OR	ON	2017/12/10 11:45

			EPO; JPO; DERWENT; IBM_TDB			
L24	0	19 and query with PSTN with fix\$5 with location	US-PGPUB; USPAT; USOCR; FPRS; EPO; JPO; DERWENT; IBM_TDB	OR	ON	2017/12/10 11:50
L25	1200478	(H04W\$/\$.CPC.	US-PGPUB; USPAT; USOCR; FPRS; EPO; JPO; DERWENT; IBM_TDB	OR	ON	2017/12/10 11:51
L26	732732	(H04B\$/\$.CPC.	US-PGPUB; USPAT; USOCR; FPRS; EPO; JPO; DERWENT; IBM_TDB	OR	ON	2017/12/10 11:52
L27	0	(G01S\$/\$.CPC.	US-PGPUB; USPAT; USOCR; FPRS; EPO; JPO; DERWENT; IBM_TDB	OR	ON	2017/12/10 11:52
L28	380030	(G01S\$/\$.CPC.	US-PGPUB; USPAT; USOCR; FPRS; EPO; JPO; DERWENT; IBM_TDB	OR	ON	2017/12/10 11:52
L29	2095275	25 OR 26 OR 28	US-PGPUB; USPAT; USOCR; FPRS; EPO; JPO; DERWENT; IBM_TDB	OR	ON	2017/12/10 11:53
L30	497514	29 and @ad<"20011023"	US-PGPUB; USPAT; USOCR; FPRS; EPO; JPO; DERWENT; IBM_TDB	OR	ON	2017/12/10 11:53
L31	6	30 and (internet or "IP") same query same navigation\$6	US-PGPUB; USPAT; USOCR; FPRS; EPO; JPO; DERWENT; IBM_TDB	OR	ON	2017/12/10 11:54
L32	0	31 and determini\$6 with device with mobile	US-PGPUB; USPAT;	OR	ON	2017/12/10 11:54

EAST Search History

			USOCR; FPRS; EPO; JPO; DERWENT; IBM_TDB			
L33	3	31 and determin\$6 with device with mobile	US-PGPUB; USPAT; USOCR; FPRS; EPO; JPO; DERWENT; IBM_TDB	OR	ON	2017/12/10 11:54

**EAST Search History (Interference)**

Ref #	Hits	Search Query	DBs	Default Operator	Plurals	Time Stamp
L34	0	internet same query same direction\$4 same assistance same navigation\$4.clm.	US-PGPUB; USPAT	OR	ON	2017/12/10 11:56
L35	52455	determin\$4 same mobile same device.clm.	US-PGPUB; USPAT	OR	ON	2017/12/10 11:57
L36	0	assistance same direction\$4 same present same location same setermin\$5.clm.	US-PGPUB; USPAT	OR	ON	2017/12/10 11:58
L37	2	assistance same direction\$4 same present same location same determin\$5.clm.	US-PGPUB; USPAT	OR	ON	2017/12/10 11:58
L38	618	obtain\$6 same fix\$2 same location same device.clm.	US-PGPUB; USPAT	OR	ON	2017/12/10 11:59
L39	0	35 and 37 and 38	US-PGPUB; USPAT	OR	ON	2017/12/10 11:59

**12/ 10/ 2017 11:59:58 AM**

**C:\Users\apatel\Documents\EAST\Workspaces\15464820.AL.wsp**

## EAST Search History

## EAST Search History (Prior Art)

Ref #	Hits	Search Query	DBs	Default Operator	Plurals	Time Stamp
L1	142	query with internet with navigation	US-PGPUB; USPAT; USOCR; FPRS; EPO; JPO; DERWENT; IBM_TDB	OR	OFF	2017/12/09 21:21
L2	826	query same internet same navigation	US-PGPUB; USPAT; USOCR; FPRS; EPO; JPO; DERWENT; IBM_TDB	OR	OFF	2017/12/09 21:21
L3	77	2 and determ\$6 with mobile with device	US-PGPUB; USPAT; USOCR; FPRS; EPO; JPO; DERWENT; IBM_TDB	OR	OFF	2017/12/09 21:27
L4	0	3 and @ad<"20011023"	US-PGPUB; USPAT; USOCR; FPRS; EPO; JPO; DERWENT; IBM_TDB	OR	OFF	2017/12/09 21:28
L5	82	2 and @ad<"20011023"	US-PGPUB; USPAT; USOCR; FPRS; EPO; JPO; DERWENT; IBM_TDB	OR	OFF	2017/12/09 21:30
L6	20	("5191532"   "5544061"   "5699255"   "5764906"   "5825306"   "5835907"   "5839088"   "5941930"   "5987375"   "6006160"   "6023654"   "6047236"   "6049711"   "6088649"   "6091956"   "6112153"   "6115655"   "6122520"   "6122594"   "6148260").PN.	US-PGPUB; USPAT; USOCR	OR	OFF	2017/12/09 21:44

12/ 9/ 2017 10:26:44 PM

C:\Users\apatel\Documents\EAST\Workspaces\15464820.AL.wsp

**EAST Search History****EAST Search History (Prior Art)**

Ref #	Hits	Search Query	DBs	Default Operator	Plurals	Time Stamp
L1	9079	(mobile or device or wtru or ue) and navigat\$6 and (internet with query) and location	US-PGPUB; USPAT; USOCR; FPRS; EPO; JPO; DERWENT; IBM_TDB	OR	ON	2017/11/28 09:21
L2	9452	(mobile or device or wtru or ue) and navigat\$6 and (internet with query) and (location or position)	US-PGPUB; USPAT; USOCR; FPRS; EPO; JPO; DERWENT; IBM_TDB	OR	ON	2017/11/28 09:22
L3	814	2 and @ad<"20011023"	US-PGPUB; USPAT; USOCR; FPRS; EPO; JPO; DERWENT; IBM_TDB	OR	ON	2017/11/28 09:22
L4	13	3 and ((direction or map) with assistan\$6)	US-PGPUB; USPAT; USOCR; FPRS; EPO; JPO; DERWENT; IBM_TDB	OR	ON	2017/11/28 09:24
L5	13	("20010044310"   "20010046884"   "20020160790"   "20020168986"   "20030216145"   "5155689"   "5353023"   "5890088"   "6029069"   "6085097"   "6456854"   "6625457"   "6633763").PN.	US-PGPUB; USPAT; USOCR	OR	OFF	2017/11/28 09:30

**11/ 28/ 2017 9:53:50 AM****C:\Users\apatel\Documents\EAST\Workspaces\15464820.AL.wsp**

<b>Issue Classification</b> 	<b>Application/Control No.</b> 15717138	<b>Applicant(s)/Patent Under Reexamination</b> REED ET AL.
	<b>Examiner</b> AJIT PATEL	<b>Art Unit</b> 2644

CPC						
Symbol					Type	Version
H04W		4		023	F	2013-01-01
G01S		5		0252	I	2013-01-01
H04B		17		318	I	2015-01-15
H04W		4		028	I	2013-01-01

CPC Combination Sets				
Symbol	Type	Set	Ranking	Version

NONE		<b>Total Claims Allowed:</b>	
(Assistant Examiner)	(Date)	30	
/AJIT PATEL/ Primary Examiner.Art Unit 2644	12/10/17	O.G. Print Claim(s)	O.G. Print Figure
(Primary Examiner)	(Date)	1	70

<b>Issue Classification</b> 	<b>Application/Control No.</b> 15717138	<b>Applicant(s)/Patent Under Reexamination</b> REED ET AL.
	<b>Examiner</b> AJIT PATEL	<b>Art Unit</b> 2644

US ORIGINAL CLASSIFICATION						INTERNATIONAL CLASSIFICATION														
CLASS		SUBCLASS				CLAIMED					NON-CLAIMED									
						H	O	4	W											
<b>CROSS REFERENCE(S)</b>																				
CLASS	SUBCLASS (ONE SUBCLASS PER BLOCK)																			

NONE		<b>Total Claims Allowed:</b>	
(Assistant Examiner)	(Date)	30	
/AJIT PATEL/ Primary Examiner.Art Unit 2644	12/10/17	O.G. Print Claim(s)	O.G. Print Figure
(Primary Examiner)	(Date)	1	70

<b>Issue Classification</b> 	<b>Application/Control No.</b> 15717138	<b>Applicant(s)/Patent Under Reexamination</b> REED ET AL.
	<b>Examiner</b> AJIT PATEL	<b>Art Unit</b> 2644

<input checked="" type="checkbox"/> <b>Claims renumbered in the same order as presented by applicant</b> <input type="checkbox"/> <b>CPA</b> <input type="checkbox"/> <b>T.D.</b> <input type="checkbox"/> <b>R.1.47</b>															
Final	Original	Final	Original	Final	Original	Final	Original	Final	Original	Final	Original	Final	Original	Final	Original
	1		17												
	2		18												
	3		19												
	4		20												
	5		21												
	6		22												
	7		23												
	8		24												
	9		25												
	10		26												
	11		27												
	12		28												
	13		29												
	14		30												
	15														
	16														

NONE		<b>Total Claims Allowed:</b>	
		30	
(Assistant Examiner)	(Date)	O.G. Print Claim(s)	O.G. Print Figure
/AJIT PATEL/ Primary Examiner.Art Unit 2644	12/10/17	1	70
(Primary Examiner)	(Date)		





UNITED STATES PATENT AND TRADEMARK OFFICE

UNITED STATES DEPARTMENT OF COMMERCE  
United States Patent and Trademark Office  
Address: COMMISSIONER FOR PATENTS  
P. O. Box 1450  
Alexandria, Virginia 22313-1450  
www.uspto.gov

APPLICATION NO.	FILING DATE	FIRST NAMED INVENTOR	ATTORNEY DOCKET NO.	CONFIRMATION NO.
15/717,138	09/27/2017	Mark Jefferson Reed	TX1000-C7	3036
59911 7590 11/17/2017 MITCH HARRIS, LLC - GENERAL P.O. BOX 1269 ATHENS, GA 30603-1269			EXAMINER	
			PATEL, AJIT	
			ART UNIT	PAPER NUMBER
			2644	
			MAIL DATE	DELIVERY MODE
			11/17/2017	PAPER

**Please find below and/or attached an Office communication concerning this application or proceeding.**

The time period for reply, if any, is set in the attached communication.



UNITED STATES PATENT AND TRADEMARK OFFICE

Commissioner for Patents  
United States Patent and Trademark Office  
P.O. Box 1450  
Alexandria, VA 22313-1450  
www.uspto.gov

Doc Code:  
TRACK1.GRANT

<b>Decision Granting Request for Prioritized Examination (Track I or After RCE)</b>	Application No.: 15/717,138
<p>1. THE REQUEST FILED <u>September 27, 2017</u> IS <b>GRANTED</b>.</p> <p>The above-identified application has met the requirements for prioritized examination</p> <p>A. <input checked="" type="checkbox"/> for an original nonprovisional application (Track I).</p> <p>B. <input type="checkbox"/> for an application undergoing continued examination (RCE).</p> <p>2. <b>The above-identified application will undergo prioritized examination.</b> The application will be accorded special status throughout its entire course of prosecution until one of the following occurs:</p> <p>A. filing a <b><u>petition for extension of time</u></b> to extend the time period for filing a reply;</p> <p>B. filing an <b><u>amendment to amend the application to contain more than four independent claims, more than thirty total claims</u></b>, or a multiple dependent claim;</p> <p>C. filing a <b><u>request for continued examination</u></b>;</p> <p>D. filing a notice of appeal;</p> <p>E. filing a request for suspension of action;</p> <p>F. mailing of a notice of allowance;</p> <p>G. mailing of a final Office action;</p> <p>H. completion of examination as defined in 37 CFR 41.102; or</p> <p>I. abandonment of the application.</p> <p>Telephone inquiries with regard to this decision should be directed to Irvin Dingle at (571)272-3210, Office of Petitions.</p> <p>Irvin Dingle <u>/Irvin Dingle/</u> [Signature]</p> <p><u>Lead Paralegal Specialist</u> (Title)</p>	

U.S. Patent and Trademark Office  
PTO-2298 (Rev. 02-2012)

**Office of Petitions: Routing Sheet**



**Application No.**

**This application is being forwarded to your office for further processing. A decision has been rendered on a petition filed in this application, as indicated below. For details of this decision, please see the document PET.OP.DEC filed on the same date as this document.**

**GRANTED**

**DISMISSED**

**DENIED**



UNITED STATES PATENT AND TRADEMARK OFFICE

UNITED STATES DEPARTMENT OF COMMERCE
United States Patent and Trademark Office
Address: COMMISSIONER FOR PATENTS
P.O. Box 1450
Alexandria, Virginia 22313-1450
www.uspto.gov

Table with 7 columns: APPLICATION NUMBER, FILING or 371(c) DATE, GRP ART UNIT, FIL FEE REC'D, ATTY.DOCKET.NO, TOT CLAIMS, IND CLAIMS. Row 1: 15/717,138, 09/27/2017, 1940, TX1000-C7, 30, 4

CONFIRMATION NO. 3036

FILING RECEIPT



000000094843155

59911
MITCH HARRIS, LLC - GENERAL
P.O. BOX 1269
ATHENS, GA 30603-1269

Date Mailed: 10/18/2017

Receipt is acknowledged of this non-provisional patent application. The application will be taken up for examination in due course. Applicant will be notified as to the results of the examination. Any correspondence concerning the application must include the following identification information: the U.S. APPLICATION NUMBER, FILING DATE, NAME OF APPLICANT, and TITLE OF INVENTION. Fees transmitted by check or draft are subject to collection. Please verify the accuracy of the data presented on this receipt. If an error is noted on this Filing Receipt, please submit a written request for a Filing Receipt Correction. Please provide a copy of this Filing Receipt with the changes noted thereon. If you received a "Notice to File Missing Parts" for this application, please submit any corrections to this Filing Receipt with your reply to the Notice. When the USPTO processes the reply to the Notice, the USPTO will generate another Filing Receipt incorporating the requested corrections

Inventor(s)

Mark Jefferson Reed, Tucson, AZ;
Stephen Michael Palik, Redondo Beach, CA;

Applicant(s)

Traxcell Technologies, LLC, Plano, TX;

Power of Attorney: The patent practitioners associated with Customer Number 59911

Domestic Priority data as claimed by applicant

This application is a CON of 15/468,265 03/24/2017
which is a CON of 15/297,222 10/19/2016 PAT 9642024
which is a CON of 14/642,408 03/09/2015 PAT 9510320
which is a CON of 11/505,578 08/17/2006 PAT 8977284
which is a CIP of 10/255,552 09/24/2002 ABN
which claims benefit of 60/327,327 10/04/2001
and claims benefit of 60/383,528 05/28/2002
and claims benefit of 60/352,761 01/29/2002
and claims benefit of 60/335,203 10/23/2001
and claims benefit of 60/383,529 05/28/2002
and claims benefit of 60/391,469 06/26/2002
and claims benefit of 60/353,379 01/30/2002
and claims benefit of 60/381,249 05/16/2002

Foreign Applications for which priority is claimed (You may be eligible to benefit from the Patent Prosecution Highway program at the USPTO. Please see http://www.uspto.gov for more information.) - None.

Foreign application information must be provided in an Application Data Sheet in order to constitute a claim to foreign priority. See 37 CFR 1.55 and 1.76.

**Permission to Access Application via Priority Document Exchange:** Yes

**Permission to Access Search Results:** Yes

Applicant may provide or rescind an authorization for access using Form PTO/SB/39 or Form PTO/SB/69 as appropriate.

**If Required, Foreign Filing License Granted:** 10/18/2017

The country code and number of your priority application, to be used for filing abroad under the Paris Convention, is **US 15/717,138**

**Projected Publication Date:** 01/25/2018

**Non-Publication Request:** No

**Early Publication Request:** No

**\*\* SMALL ENTITY \*\***

**Title**

INTERNET QUERIED DIRECTIONAL NAVIGATION SYSTEM WITH MOBILE AND FIXED  
ORIGINATING LOCATION DETERMINATION

**Preliminary Class**

**Statement under 37 CFR 1.55 or 1.78 for AIA (First Inventor to File) Transition Applications:** No

### **PROTECTING YOUR INVENTION OUTSIDE THE UNITED STATES**

Since the rights granted by a U.S. patent extend only throughout the territory of the United States and have no effect in a foreign country, an inventor who wishes patent protection in another country must apply for a patent in a specific country or in regional patent offices. Applicants may wish to consider the filing of an international application under the Patent Cooperation Treaty (PCT). An international (PCT) application generally has the same effect as a regular national patent application in each PCT-member country. The PCT process **simplifies** the filing of patent applications on the same invention in member countries, but **does not result** in a grant of "an international patent" and does not eliminate the need of applicants to file additional documents and fees in countries where patent protection is desired.

Almost every country has its own patent law, and a person desiring a patent in a particular country must make an application for patent in that country in accordance with its particular laws. Since the laws of many countries differ in various respects from the patent law of the United States, applicants are advised to seek guidance from specific foreign countries to ensure that patent rights are not lost prematurely.

Applicants also are advised that in the case of inventions made in the United States, the Director of the USPTO must issue a license before applicants can apply for a patent in a foreign country. The filing of a U.S. patent application serves as a request for a foreign filing license. The application's filing receipt contains further information and guidance as to the status of applicant's license for foreign filing.

Applicants may wish to consult the USPTO booklet, "General Information Concerning Patents" (specifically, the section entitled "Treaties and Foreign Patents") for more information on timeframes and deadlines for filing foreign patent applications. The guide is available either by contacting the USPTO Contact Center at 800-786-9199, or it can be viewed on the USPTO website at <http://www.uspto.gov/web/offices/pac/doc/general/index.html>.

For information on preventing theft of your intellectual property (patents, trademarks and copyrights), you may wish to consult the U.S. Government website, <http://www.stopfakes.gov>. Part of a Department of Commerce initiative, this website includes self-help "toolkits" giving innovators guidance on how to protect intellectual property in specific countries such as China, Korea and Mexico. For questions regarding patent enforcement issues, applicants may call the U.S. Government hotline at 1-866-999-HALT (1-866-999-4258).

**LICENSE FOR FOREIGN FILING UNDER**  
**Title 35, United States Code, Section 184**  
**Title 37, Code of Federal Regulations, 5.11 & 5.15**

**GRANTED**

The applicant has been granted a license under 35 U.S.C. 184, if the phrase "IF REQUIRED, FOREIGN FILING LICENSE GRANTED" followed by a date appears on this form. Such licenses are issued in all applications where the conditions for issuance of a license have been met, regardless of whether or not a license may be required as set forth in 37 CFR 5.15. The scope and limitations of this license are set forth in 37 CFR 5.15(a) unless an earlier license has been issued under 37 CFR 5.15(b). The license is subject to revocation upon written notification. The date indicated is the effective date of the license, unless an earlier license of similar scope has been granted under 37 CFR 5.13 or 5.14.

This license is to be retained by the licensee and may be used at any time on or after the effective date thereof unless it is revoked. This license is automatically transferred to any related applications(s) filed under 37 CFR 1.53(d). This license is not retroactive.

The grant of a license does not in any way lessen the responsibility of a licensee for the security of the subject matter as imposed by any Government contract or the provisions of existing laws relating to espionage and the national security or the export of technical data. Licensees should apprise themselves of current regulations especially with respect to certain countries, of other agencies, particularly the Office of Defense Trade Controls, Department of State (with respect to Arms, Munitions and Implements of War (22 CFR 121-128)); the Bureau of Industry and Security, Department of Commerce (15 CFR parts 730-774); the Office of Foreign Assets Control, Department of Treasury (31 CFR Parts 500+) and the Department of Energy.

**NOT GRANTED**

No license under 35 U.S.C. 184 has been granted at this time, if the phrase "IF REQUIRED, FOREIGN FILING LICENSE GRANTED" DOES NOT appear on this form. Applicant may still petition for a license under 37 CFR 5.12, if a license is desired before the expiration of 6 months from the filing date of the application. If 6 months has lapsed from the filing date of this application and the licensee has not received any indication of a secrecy order under 35 U.S.C. 181, the licensee may foreign file the application pursuant to 37 CFR 5.15(b).

---

***SelectUSA***

The United States represents the largest, most dynamic marketplace in the world and is an unparalleled location for business investment, innovation, and commercialization of new technologies. The U.S. offers tremendous resources and advantages for those who invest and manufacture goods here. Through SelectUSA, our nation works to promote and facilitate business investment. SelectUSA provides information assistance to the international investor

community; serves as an ombudsman for existing and potential investors; advocates on behalf of U.S. cities, states, and regions competing for global investment; and counsels U.S. economic development organizations on investment attraction best practices. To learn more about why the United States is the best country in the world to develop technology, manufacture products, deliver services, and grow your business, visit <http://www.SelectUSA.gov> or call +1-202-482-6800.

**CERTIFICATION AND REQUEST FOR PRIORITIZED EXAMINATION  
 UNDER 37 CFR 1.102(e) (Page 1 of 1)**

First Named Inventor:	Reed	Nonprovisional Application Number (if known):	
Title of Invention:	INTERNET QUERIED DIRECTIONAL NAVIGATION SYSTEM WITH MOBILE AND FIXED ORIGINATING LOCATION DETERMINATION		

**APPLICANT HEREBY CERTIFIES THE FOLLOWING AND REQUESTS PRIORITIZED EXAMINATION FOR THE ABOVE-IDENTIFIED APPLICATION.**

1. The processing fee set forth in 37 CFR 1.17(i)(1) and the prioritized examination fee set forth in 37 CFR 1.17(c) have been filed with the request. The publication fee requirement is met because that fee, set forth in 37 CFR 1.18(d), is currently \$0. The basic filing fee, search fee, and examination fee are filed with the request or have been already been paid. I understand that any required excess claims fees or application size fee must be paid for the application.
2. I understand that the application may not contain, or be amended to contain, more than four independent claims, more than thirty total claims, or any multiple dependent claims, and that any request for an extension of time will cause an outstanding Track I request to be dismissed.
3. The applicable box is checked below:

**I.  Original Application (Track One) - Prioritized Examination under § 1.102(e)(1)**

- i. (a) The application is an original nonprovisional utility application filed under 35 U.S.C. 111(a). This certification and request is being filed with the utility application via EFS-Web.  
 ---OR---  
 (b) The application is an original nonprovisional plant application filed under 35 U.S.C. 111(a). This certification and request is being filed with the plant application in paper.
- ii. An executed inventor's oath or declaration under 37 CFR 1.63 or 37 CFR 1.64 for each inventor, **or** the application data sheet meeting the conditions specified in 37 CFR 1.53(f)(3)(i) is filed with the application.

**II.  Request for Continued Examination - Prioritized Examination under § 1.102(e)(2)**

- i. A request for continued examination has been filed with, or prior to, this form.
- ii. If the application is a utility application, this certification and request is being filed via EFS-Web.
- iii. The application is an original nonprovisional utility application filed under 35 U.S.C. 111(a), or is a national stage entry under 35 U.S.C. 371.
- iv. This certification and request is being filed prior to the mailing of a first Office action responsive to the request for continued examination.
- v. No prior request for continued examination has been granted prioritized examination status under 37 CFR 1.102(e)(2).

Signature <b>/Andrew Mitchell Harris #42,638/</b>	Date <b>09-27-2017</b>
Name (Print/Typed) <b>Andrew M. Harris</b>	Practitioner Registration Number <b>42638</b>

**Note:** This form must be signed in accordance with 37 CFR 1.33. See 37 CFR 1.4(d) for signature requirements and certifications. Submit multiple forms if more than one signature is required.\*

\*Total of \_\_\_\_\_ forms are submitted.



## Privacy Act Statement

The **Privacy Act of 1974 (P.L. 93-579)** requires that you be given certain information in connection with your submission of the attached form related to a patent application or patent. Accordingly, pursuant to the requirements of the Act, please be advised that: (1) the general authority for the collection of this information is 35 U.S.C. 2(b)(2); (2) furnishing of the information solicited is voluntary; and (3) the principal purpose for which the information is used by the U.S. Patent and Trademark Office is to process and/or examine your submission related to a patent application or patent. If you do not furnish the requested information, the U.S. Patent and Trademark Office may not be able to process and/or examine your submission, which may result in termination of proceedings or abandonment of the application or expiration of the patent.

The information provided by you in this form will be subject to the following routine uses:

1. The information on this form will be treated confidentially to the extent allowed under the Freedom of Information Act (5 U.S.C. 552) and the Privacy Act (5 U.S.C. 552a). Records from this system of records may be disclosed to the Department of Justice to determine whether disclosure of these records is required by the Freedom of Information Act.
2. A record from this system of records may be disclosed, as a routine use, in the course of presenting evidence to a court, magistrate, or administrative tribunal, including disclosures to opposing counsel in the course of settlement negotiations.
3. A record in this system of records may be disclosed, as a routine use, to a Member of Congress submitting a request involving an individual, to whom the record pertains, when the individual has requested assistance from the Member with respect to the subject matter of the record.
4. A record in this system of records may be disclosed, as a routine use, to a contractor of the Agency having need for the information in order to perform a contract. Recipients of information shall be required to comply with the requirements of the Privacy Act of 1974, as amended, pursuant to 5 U.S.C. 552a(m).
5. A record related to an International Application filed under the Patent Cooperation Treaty in this system of records may be disclosed, as a routine use, to the International Bureau of the World Intellectual Property Organization, pursuant to the Patent Cooperation Treaty.
6. A record in this system of records may be disclosed, as a routine use, to another federal agency for purposes of National Security review (35 U.S.C. 181) and for review pursuant to the Atomic Energy Act (42 U.S.C. 218(c)).
7. A record from this system of records may be disclosed, as a routine use, to the Administrator, General Services, or his/her designee, during an inspection of records conducted by GSA as part of that agency's responsibility to recommend improvements in records management practices and programs, under authority of 44 U.S.C. 2904 and 2906. Such disclosure shall be made in accordance with the GSA regulations governing inspection of records for this purpose, and any other relevant (*i.e.*, GSA or Commerce) directive. Such disclosure shall not be used to make determinations about individuals.
8. A record from this system of records may be disclosed, as a routine use, to the public after either publication of the application pursuant to 35 U.S.C. 122(b) or issuance of a patent pursuant to 35 U.S.C. 151. Further, a record may be disclosed, subject to the limitations of 37 CFR 1.14, as a routine use, to the public if the record was filed in an application which became abandoned or in which the proceedings were terminated and which application is referenced by either a published application, an application open to public inspection or an issued patent.
9. A record from this system of records may be disclosed, as a routine use, to a Federal, State, or local law enforcement agency, if the USPTO becomes aware of a violation or potential violation of law or regulation.

## **INTERNET QUERIED DIRECTIONAL NAVIGATION SYSTEM WITH MOBILE AND FIXED ORIGINATING LOCATION DETERMINATION**

**[0001]** The present Application is a Continuation of U.S. Patent Application Ser. No. 15/468,265 filed on March 24, 2017 and published as U.S. Patent Publication No. 20170195847 on July 6, 2017, which is a Continuation of U.S. Patent Application Ser. No. 15/297,222, filed on October 19, 2016, and issued as U.S. Patent 9,642,024 on May 2, 2017, which is a Continuation of U.S. Patent Application Ser. No. 14/642,408, filed on March 9, 2015 and issued as U.S. Patent No. 9,510,320 on November 29, 2016, which is a Continuation of U.S. Patent Application Ser. No. 11/505,578, filed on August 17, 2006 and issued as U.S. Patent 8,977,284 on March 10, 2015, which is a Continuation-in-part of U.S. Patent Application Ser. No. 10/255,552, filed on September 24, 2002 and published as U.S. Patent Publication No. 20030134648 on July 17, 2003, and claims priority thereto under 35 U.S.C. §120. U.S. Patent Application Ser. No. 10/255,552 claims priority under 35 U.S.C. §119(e) to U.S. Provisional Patent Application Ser. No. 60/327,327 filed on October 4, 2001, U.S. Provisional Patent Application Ser. No. 60/383,528 filed on May 28, 2002, U.S. Provisional Patent Application Ser. No. 60/352,761 filed on January 29, 2002, U.S. Provisional Patent Application Ser. No. 60/335,203 filed on October 23, 2001, U.S. Provisional Patent Application Ser. No. 60/383,529 filed on May 28, 2002, U.S. Provisional Patent Application Ser. No. 60/391,469 filed on June 26, 2002, U.S. Provisional Patent Application Ser. No. 60/353,379 filed on January 30, 2002 and U.S. Provisional Patent Application Ser. No. 60/381,249 filed on May 16, 2002. The disclosures of all of the above-referenced U.S. Patent Applications are incorporated herein by reference.

### **FIELD OF THE INVENTION**

**[0002]** The present invention is directed generally to a system and method for locating mobile wireless devices, and more specifically to a mobile wireless network using a hierarchical location determination scheme.

## **BACKGROUND OF THE INVENTION**

**[0003]** Wireless networks **100** are becoming increasingly important worldwide. Wireless networks **100** are rapidly replacing conventional wire-based telecommunications systems in many applications. Cellular radio telephone networks ("CRT"), and specialized mobile radio and mobile data radio networks are examples. The general principles of wireless cellular telephony have been described variously, for example in U.S. Pat. No. 5,295, 180 to Vendetti, et al., which is incorporated herein by reference. There is great interest in using existing infrastructures of wireless networks **100** for locating people and/or objects in a cost effective manner. Such a capability would be invaluable in a variety of situations, especially in emergency or crime situations. Due to the substantial benefits of such a location system, several attempts have been made to design and implement such a system. Systems have been proposed that rely upon signal strength and triangulation techniques to permit location include those disclosed in U.S. Pat. No. 4,818,998 and 4,908,629 to Apsell et al. ("the Apsell patents") and U.S. Pat. No. 4,891,650 to Sheffer ("the Sheffer patent"). However, these systems have drawbacks that include high expense in that special purpose electronics are required.

**[0004]** Furthermore, the systems are generally only effective in line-of-sight conditions, such as rural settings. Radio wave multipath, refractions and ground clutter cause significant problems in determining the location of a signal source in most geographical areas that are more than sparsely populated. Moreover, these drawbacks are particularly exacerbated in dense urban canyon (city) areas, where errors and/or conflicts in location measurements can result in substantial inaccuracies.

**[0005]** Another example of a location system using time difference of arrival (TDOA) and triangulation for location are satellite-based systems, such as the military and commercial versions of the global positioning satellite system (GPS). GPS can provide accurate position from a time-based signal received simultaneously from at least three satellites. A ground-based GPS receiver at or near the object to be located determines the difference between the time at which each satellite transmits a time signal and the time at which the signal is received and, based on the time differentials, determines the object's location. However, the GPS is impractical in many applications. The signal power levels from the satellites are low and the GPS receiver

requires a clear, line-of-sight path to at least three satellites above a horizon greater than about 60 degrees for effective operation. Accordingly, inclement weather conditions, such as clouds, terrain features, such as hills and trees, and buildings restrict the ability of the GPS receiver to determine its position. Furthermore, the initial GPS signal detection process for a GPS receiver can be relatively long (i.e., several minutes) for determining the receiver's position. Such delays are unacceptable in many applications such as, for example, emergency response and vehicle tracking. Additionally there exists no one place that this location information is stored such that a plurality of wireless devices **104** could be located on a geographic basis.

### Summary of Factors Affecting RF Propagation

[0006] The physical radio propagation channel perturbs signal strength, causing rate changes, phase delay, low signal to noise ratios (e.g.,  $ell$  for the analog case, or  $E_b/no$ , RF energy per bit, over average noise density ratio for the digital case) and doppler-shift. Signal strength is usually characterized by:

- Free space path loss ( $L_p$ )
- Slow fading loss or margin ( $L_{slow}$ )
- Fast fading loss or margin ( $L_{fast}$ )

[0007] Loss due to slow fading includes shadowing due to clutter blockage (sometimes included in l.p). Fast fading is composed of multipath reflections which cause: 1) delay spread; 2) random phase shift or rayleigh fading, and 3) random frequency modulation due to different doppler shifts on different paths.

Summing the path loss and the two fading margin loss components from the above yields a total path loss of:

$$L_{total} = L_p + L_{slow} + L_{fast}$$

[0008] Referring to **FIG. 3**, the figure illustrates key components of a typical cellular and PCS power budget design process. The cell designer increases the transmitted power  $P_{TX}$  by the shadow fading margin  $L_{slow}$  which is usually chosen to be within the 1-2 percentile of the slow fading probability density function (PDF) to minimize the probability of unsatisfactorily low received power level  $P_{RX}$  at the receiver. The  $P_{RX}$  level must have enough signal to noise energy level (e.g., 10 dB) to overcome the receiver's internal noise level (e.g., -118 dBm in the case of cellular 0.9 GHz), for a minimum voice quality standard. Thus in the example  $P_{RX}$  must never be below -108 dBm, in order to maintain the quality standard. Additionally the short term fast signal fading due to multipath propagation is taken into account by deploying fast fading margin  $L_{fast}$ , which is typically also chosen to be a few percentiles of the fast fading distribution. The 1 to 2

percentiles compliment other network blockage guidelines. For example the cell base station traffic loading capacity and network transport facilities are usually designed for a 1-2 percentile blockage factor as well. However, in the worst-case scenario both fading margins are simultaneously exceeded, thus causing a fading margin overload.

#### **Detailed Description Of The Prior Art**

[0009] Turning to **FIG. 1** is a typical second-generation wireless network **100** architecture designed for a code division multiple access (CDMA) and is similar for a time division multiple access (TOMA) or others such as GSM. These are all digital systems that may or may not have the ability to operate in an analog mode. A general overview of the operation of this system will begin when the wireless device user **102** initiates a call with the wireless device **104**. A wireless device **104** may take the form of a wireless device **104**, personal digital assistant (PDA), laptop computer, personal communications system, vehicle mounted system, etc. Radio frequency (RF) signal **106** is sent from the wireless device **104** to a radio tower and base-station transceiver subsystem (BTS) **300 (FIG. 3)**, having a global positioning system (GPS) receiver **110-A, 110•8, or 110-C** as part of the BTS. The GPS receiver **302** (described in **FIG. 3**) receives a GPS satellite network signal **112** from the GPS satellite network **114**, used by the radio tower with network BTS **108** for timing information. That information is used by the BTS to synchronize the communications signal and allow decoding of the digitized wireless device **104** radio frequency signal **106**. The call is then carried from the radio tower and BTS with GPS receiver **110-A, 110-B, or 110-C** through a wired link **116** via a T1, T3, microwave link, etc, to the base station controller (BSC) **118-A** with vocoding **120**, CIS **122**, and a backhaul I/F **124**, where the call is formatted and coded into data packets by the BSS manager **126** via an intersystem logical connection **128**. The call is then sent to the switch **130** via intersystem logical connections **132**, where the call is then forwarded through intersystem logical connections **150** to the PSTN **138**. The call may also be directly routed to another wireless device **104** on the wireless network **100**.

[0010] From the PSTN **138**, the call is forwarded through a connection from the PSTN **138** to communications link **140** and then to land lines **142**. As the call proceeds, the words or data from the wireless device user **102** and the ultimate person or device at the receiving end of the call, are formatted, coded and decoded again and again, in the manor described above, throughout the

conversation as the conversation or data volleys back and forth. Turning to **FIG. 2** is a typical third generation (3G) wireless network **200**. The only major difference between the second generation wireless network **100** and third generation wireless network's **200** architecture is the addition of a packet data service node (PDSN) **202** and in the inner system logical connection **204** which connects the PDSN **202** to the BSC **118-B**. However, It should be noted that the expansions in architecture do not affect current implementation of this machine and/or process as described by this patent. The methodology is the same as in the second generation wireless network **100** (FIG. 1) and for completeness the periphery 3G **200** components and their logical locations have been shown.

[0011] As other technologies in network design emerge, it is important to realize that modifications and improvements can be made to this design and patent while retaining the spirit in which it was written. FIG. 1 and FIG. 2 demonstrates the logical locations in which this patent applies to current technology. It is both obvious and required that some changes would have to be made to accommodate future technologies and again are understood to be within the spirit of this patent.

#### **Ability to Locate Wireless Device**

[0012] There are numerous methods for obtaining the location of a wireless device **104**, which have been taught in the prior art. Most common are in wireless networks (CDMA, TOMA, GSM, etc). All of these wireless networks **100** currently use similar hardware, which these patented location methods take advantage of.

[0013] Referring now to **FIG. 3**, details of a typical three sector radio tower **110-A**. The BTS **300** with a GPS receiver **302** are shown. This radio tower **110-A** exists in most current wireless networks **100** (FIG. 1) and **200** (FIG. 2) and is used most commonly. Its inclusion is for completeness of this document.

[0014] Still referring to **FIG. 3**, the typical three sector radio tower **110-A** with BTS **300** setup includes a BSC **118-A**, and **118-B** which is connected to a BTS **300** through a T1 **116** or a microwave link **304**. The GPS has a receiver **302** that is used in its operation to establish timing

information for communication synchronization. The radio tower **110-A** has 3 sectors. Each sector comprises one primary receive antenna **306-A, 308-A, 310-A**, and one diversity receive antenna **306-C, 308-C, 310-C**. Each sector also has one transmit antenna **306-B, 308-B, 310-B**. These receiver antennas and transmit antennas are elevated by the radio tower pole **312** and connected to the BTS by antenna leads **314**.

[0015] **FIG. 4** illustrates the typical footprint characteristics (side view) of a typical three-sector radio tower antenna **110-A**, such as described in **FIG. 3**. Each sector has a primary lobe **400** (which corresponds with its primary directivity), multiple side lobes **402-A** and **402-B**, and multiple rear lobes **404**.

[0016] **FIG. 5** illustrates the typical footprint characteristics (top view) of a typical three-sector radio tower antenna **110-A**, such as described in **FIG. 3**. Each sector has a primary lobe **400** (which corresponds with its primary directivity), multiple side lobes **402-A**, and **402-B**, and multiple rear lobes **404**.

**Location Determined As Follows:**

[0017] As many other patents go into great depth on location-based methods, for completeness, a brief description of the methods preferred by this patent will be discussed.

[0018] **FIG. 6** shows general methods for triangulation with three radio towers; **110-A, 110-B,** and **110-C**. This method is covered in numerous other patents but the basic idea is included for completeness.

[0019] Still referring to **FIG. 6** round trip delay (RTD) from each radio tower and BTS **110-A, 110-B** and **110-C** is used to calculate distance from radio towers to the wireless device **104**. To calculate distance **600-A, 600-B,** and **600-C**, take the RTD (unit in seconds) and multiply by the speed of light (or speed in relative medium of propagation) and divide by two.



$$\frac{RTD * c}{2} \cdot D, \quad D = \text{Distance in meters from tower (c = speed of light)}$$

Having done so, you can calculate the position, relative to the known geological position of the towers **110-A**, **110-B**, and **110-C**, of the wireless device **104**.

[0020] To calculate position you find the intersection of three concentric spheres around each radio tower and BTS **110-A**, **110-B**, and **110-C** with each radius equaling the distance **600-A**, **600-B**, and **600-C** to the wireless device **104** from that radio tower and BTS. The wireless device **104** location is the intersection of the three spheres.

[0021] **FIG. 7** shows a two-tower location finding method as taught in the prior art. It is included for completeness of this document. It uses two towers **110-A**, and **110-B** with a wireless device **104** at distances of **700-A**, and **700-B**.

[0022] Because each tower has more than one sector, as the wireless device **104** approaches a radio tower **110-A** or **110-B**, it may be talking to more than one sector on a single radio tower as is illustrated in **FIG. 4**, **FIG. 5**, and **FIG. 6**. When this occurs, there is a critical distance below which the time it takes for two sectors on a single tower to reach the wireless device **104** is indistinguishable due to hardware calculation limitations. This would make the distance from both sectors (which are already very close, being located on the same tower) appear the same. In this case you should regard the tower as having only one sector, characterized by the distance (equal) from the two sectors. Now, using this as a base you can calculate the location at the wireless device **104** by examining the intersection on the two spheres (one from each tower) and the intersection of the vertical plane between the two towers **110-A** and **110-B**. This should result in a single point and hence the location of the wireless device **104**.

[0023] **FIG. 8** shows a one-tower **110-A** location method. It shows a tower (3 sectors) and three distances **800-A**, **800-B**, **800-C** from a wireless device **104**.

[0024] In this case, the wireless device **104** has approached a radio tower **110-A** so closely that is talking to three sectors on the site. Because, at this proximity, the distance **800-A**, **800-B** and

**800-C** between the three sectors (**Sector 1, Sector 2, and Sector 3**) on the radio tower **110-A** is so negligible, the accuracy is reduced to predicting the wireless device's **104** location with one concentric sphere around the radio tower **110-A**, with a radius equaling the distance **800-A, 800-8, or 800-C** from any site as calculated above. Relative direction can be computed using the sector (**Sector 1, Sector 2, or Sector 3**) with the strongest receive power from the wireless device **104** as the likely direction to the wireless device **104** (assuming highly directive antennas are being used).

[0025] The problem with these methods is that they do not disclose a means for formatting and structuring the decoded data from a plurality of wireless devices **104** into a database or other means of collaboration of data. This database could create a universal standard that could be accessed by other applications such as navigation apparatuses; wireless networks **100** for network tuning purposes; or many other applications.

#### **Summary of the Invention**

[0026] The primary object of the invention is to provide a process and machine for transferring acquired geographical data, user information, date/time information and/or user controlled settings information for a plurality of wireless devices **104** to a database providing it as a resource for other software applications.

[0027] Another object of the invention is to provide a user location database manager (ULDM) **904 (FIG. 9)** comprising a machine and process for decoding and converting acquired geographical data, user information, date/time information and/or user controlled settings information into a universal standard which is a practical and usable format such as, for example, longitude/latitude for applications in other hardware and/or software.

[0028] A further object of the invention is to provide a user location database (ULD) **900 (FIG. 9)** comprising a means for storing geographical data, user information, date/time information, other defined data, and/or user controlled settings information for a plurality of wireless devices **104**.

**[0029]** Yet another object of the invention is to provide a user location database coordinator (ULDC) **908 (FIG. 9)** comprising a means for interfacing a plurality of user location databases (ULD) **900** and allowing remote query of data of a herein created network of ULD's **1512 (FIG. 15)** from individual or a plurality of attached ULD's **1512**. A further object of the ULDC **908** is to provide a feature for redundancy and input/output capable ports for expansion.

**[0030]** Yet another object of the invention is to provide a user location database coordinator network (ULDCN) **1600 (FIG. 16)** comprising a means for querying a plurality of user ULD's **1512** and/or ULD's **1512** attached to any ULDC **908**.

**[0031]** Still yet another object of the invention is to provide a means for access by a plurality of "e-mobility" services **144** that could take advantage of the ULD **900**.

**[0032]** Another object of the invention is to provide a means for interfacing directly form a BSS manager **126** to the user location database manager (ULDM) **904** for maintenance and direct access of said features.

**[0033]** Still yet another object of the invention is to provide a hierarchy process for query (HPQ) comprising a means for a user location database coordinator network (ULDCN) **1600** to query a plurality of user location databases coordinators (ULDC) **908** in a programmable order so as to optimize the query results.

**[0034]** Another object of the invention is to provide a hierarchy of user location methods (HULM) comprising a means for the user location database manager(s) to select the most accurate location method, from a programmable plurality of location methods, for locating the plurality of wireless devices **104** according to variable conditions that exist within the wireless network or location information from the wireless device **104** including GPS and triangulation.

**[0035]** Another object of the invention is to provide a user control setting comprising a means for a privacy flag in the ULD **900** database entry for a device to be activated/deactivated/semi-active for privacy reasons so that the user's location is not monitored or monitored anonymously.

**[0036]** A further object of the invention is to provide for a machine/process **ULDC 908** for transferring acquired geographical data, user information, date/time information and/or user controlled settings information for a plurality of wireless devices **104** that explicitly contain GPS equipment, to a database providing it as a resource for other applications.

**[0037]** Still yet another object of the invention is to provide the **ULD 900** as database resource for:

- Applications such as "911" emergency crew, police, etc., to track/find wireless devices through **ULDC 908** queries.
- Applications such as wireless network tuning; in order to save engineers some of the time and expense required to gather field data, which may be used.
- Applications such as navigational mapping programs and/or apparatus that may be used, for example, to aid in mapping vehicle travel routes in order to avoid traffic jams and find faster moving routes of travel.
- Applications such as a vehicle traffic monitoring system, which for example, could be used by emergency vehicles, traffic engineers to monitor traffic, or by employers to monitor and track employee travels, locations and estimated times of arrival.
- Applications such as a resource for a telephone recording law database for recording of telephone conversations at or near the switch **130**, or on the wireless device **104**, to as to comply with recording laws of the city, county, state or country.
- Applications such as a geographic advertising system (**GAS**) resource for targeting advertising (coupons, sales, special offers, etc.) offers (solicitations) to users of wireless devices **102** based on the wireless device's **104** location or for users of wireless devices **102** to query advertising offers, prices for goods and services based on the location of the wireless device **104**.

**[0038]** Other objects and advantages of the present invention will become apparent from the following descriptions, taken in connection with the accompanying drawings, wherein, by way of illustration and example, an embodiment of the present invention is disclosed.

**[0039]** A machine for transferring acquired data, user information, date/time information and/or user controlled settings information for a plurality of wireless devices **104** to a database providing it as a resource for other software applications that comprise of:

- ULDM **904** having a means for decoding and converting the acquired geographical data, user information, date/time information and/or user controlled settings information into a usable format
- ULD **900** comprising a means for storing the geographical data, user information, date/time information and/or user controlled settings information for the plurality of wireless devices
- ULDC **908** comprising a means for interfacing a plurality of ULD's **1512** and allowing remote query of ULD **900** database entries.

**[0040]** A process for transferring the acquired geographical data, user information, date/time information and/or user controlled settings information for the plurality of wireless devices **104** to the dynamic database providing it as said resource for other applications comprising the steps of decoding and converting the acquired geographical data, user information, date/time information, other defined data, and/or user controlled settings information into a usable format for the ULDM **904**. Additionally storing the decoded and converted geographical data, user information, date/time information, other defined data, and/or user controlled settings information for the plurality of wireless devices **104** into the ULD **900**. Further, interfacing the plurality of ULD's **1512** into the ULDC **908** and any ULDC **908** network.

**[0041]** The drawings constitute a part of this specification and include exemplary embodiments to the invention, which may be embodied in various forms. It is to be understood that in some instances various aspects of the invention may be shown exaggerated or enlarged to facilitate an understanding of the invention.

#### **Brief Description of the Drawings**

**[0042] FIG. 1 TYPICAL SECOND GENERATION WIRELESS NETWORK ARCHITECTURE (PRIOR ART)**

**[0043] FIG. 2 TYPICAL THIRD GENERATION WIRELESS NETWORK ARCHITECTURE (PRIOR ART)**

**[0044] FIG. 3 TYPICAL THREE SECTOR RADIO TOWER CONFIGURATION (PRIOR ART)**

**[0045] FIG. 4 TYPICAL FOOTPRINT CHARACTERISTICS OF EACH SECTOR (SIDE VIEW) (PRIOR ART)**

**[0046] FIG. 5 TYPICAL FOOTPRINT CHARACTERISTICS OF EACH SECTOR (TOP VIEW) (PRIOR ART)**

**[0047] FIG. 6 THREE TOWER LOCATION METHOD (PRIOR ART)**

**[0048] FIG. 7 TWO TOWER LOCATION METHOD (PRIOR ART)**

**[0049] FIG. 8 SINGLE TOWER LOCATION METHOD (PRIOR ART)**

**[0050] FIG. 9 TYPICAL SECOND GENERATION WIRELESS NETWORK ARCHITECTURE WITH EMBODIMENTS**

**[0051] FIG.10 TYPICAL THIRD GENERATION WIRELESS NETWORK ARCHITECTURE WITH EMBODIMENTS .**

**[0052] FIG. 11 FLOWCHART OF TRACKING WIRELESS DEVICE'S LOCATION**

**[0053] FIG. 12 INTERWORKING BETWEEN BSC, SWITCH, AND ULDM**

**[0054] FIG. 13 USER LOCATION DATABASE COORDINATOR (MARKET LEVEL QUEERY)**

**[0055] FIG. 14 USER LOCATION DATABASE COORDINATOR FLOWCHART**

**[0056] FIG. 15 GENERIC USER LOCATION DATABASE COORDINATOR COMPONENTS**

**[0057] FIG. 16 USER LOCATION DATABASE COORDINATOR (MARKET BASED SYSTEM)**

**[0058] FIG. 17 USER LOCATION DATABASE COORDINATOR NETWORK (REGION BASED SYSTEM)**

**[0059] FIG. 18 USER LOCATION DATABASE COORDINATOR NETWORK (DIRECT SYSTEM)**

**[0060] FIG. 19 ULDC EXTERNAL QUERY CONNECTIVITY**

**[0061] FIG. 20 HIERARCHY OF LOCATION METHODS**

**[0062] FIG. 21 VALIDATION OF LOCATION METHODS**

**[0063] FIG. 22 E-MOBILITY USER LOCATION DATABASE QUERIES**

**[0064] FIG. 23 RF REMOTE LINK COMPONENTS**

**[0065] FIG. 24 RF REMOTE LINK TO REMOTE MOBILE DEVICE**

**[0066] FIG. 25 RF REMOTE LINK NETWORK**

**[0067] FIG. 26 REMOTE MOBILE DEVICE CONTROL HARDWARE**

- [0068] FIG. 27 COMPONENTS UTILIZED BY ULDM
- [0069] FIG. 28 INTER WORKING SYSTEM DIAGRAM
- [0070] FIG. 29 PHYSICAL REALIZATION OF PREFERRED EMBODIMENTS
- [0071] FIG. 30 STANDARDIZATION/CONVERSION SOFTWARE
- [0072] FIG. 31 BSC ACCESS CONTROL SOFTWARE
- [0073] FIG. 32 USER INTERFACE SOFTWARE
- [0074] FIG. 33 DEVICE LOCATION SOFTWARE
- [0075] FIG. 34 TRAGETING DEVICES TO TRACK
- [0076] FIG. 35 A PRIMARY ANALYTIC SOFTWARE
- [0077] FIG. 35 B PRIMARY ANALYTIC SOFTWARE (CONTINUED)
- [0078] FIG. 35 C PRIMARY ANALYTIC SOFTWARE (CONTINUED)
- [0079] FIG. 36 MONITORING SOFTWARE FLOWCHART
- [0080] FIG. 37 CASE FILE GENERATION
- [0081] FIG. 38 A FAULT DIAGNOSIS/CORRECTION SOFTWARE
- [0082] FIG. 38 B FAULT DIAGNOSIS/CORRECTION SOFTWARE (CONTINUED)
- [0083] FIG. 38-C FAULT DIAGNOSIS/CORRECTION SOFTWARE (CONTINUED)



[0084] FIG. 39 CORRELATED MAPPING SOFTWARE FLOWCHART

[0085] FIG. 40 DISPLAY SOFTWARE FLOWCHART

[0086] FIG. 41 FINAL DISPLAY OUTPUT

[0087] FIG. 42 PRO-ACTIVE NETWORK TUNING SOFTWARE

[0088] FIG. 43 ACTIVE WIRELESS UNIT DENSITY GEOGRAPHIC ZONING

[0089] FIG. 44 ACTIVE WIRELESS UNIT DENSITY

[0090] FIG. 45 TERRAIN INTEFERENCE NON-RADIAL ZONING

[0091] FIG. 46 TERRAIN INTEFERENCE RADIAL DIVIDED ZONING

[0092] FIG. 47 TERRAIN INTEFERENCE RADIAL DIVIDED BORDER ZONES

[0093] FIG. 48 THERMAL PROCESS FLOWCHART

[0094] FIG. 49 ACTIVE WIRELESS UNIT DENSITY PROCESS

[0095] FIG. 50 TERRAIN TUNING PROCESS

[0096] FIG. 51 NETWORK EQUIPMENT TUNING FLOWCHART

[0097] FIG. 52 NTS PRO-ACTIVE SYSTEM MENU

[0098] FIG. 53 USER LOGS INTO SYSTEM

[0099] FIG. 54 ENTRY OF DESIRED TELEPHONE NUMBER

[0100] FIG. 55 USER CHOICES MENU

[0101] FIG. 56 USER SELECTS BUILDINGS TO DISPLAY

[0102] FIG. 57 ADDING) DELEATING AND EDITING PHONEBOOK ENTRIES

[0103] FIG. 58 USER SELECTION ON BUILDINGS TO DISPLAY

[0104] FIG. 59 "BUILDING MEMORY" USER'S CHOICE MENU

[0105] FIG. 60 "BUILDING MEMORY" CONTINUED

[0106] FIG. 61 CATEGORIZING BUILDING MEMORY

[0107] FIG. 62 "LISTING" ADDED TO "BUILDING MEMORY"

[0108] FIG. 63 "NAME" ADDED TO "BUILDING MEMORY"

[0109] FIG. 64 "CATEGORY" ADDED TO "BUILDING MEMORY"

[0110] FIG. 65 "ADDRESS" ADDED TO "BUILDING MEMORY"

[0111] FIG. 66 "PHONE NUMBER" ADDED TO "BUILDING MEMORY"

[0112] FIG. 67 DISPLAY OF CALL HISTORY

[0113] FIG. 68 PRINT CALL HISTORY

[0114] FIG. 69 ADD CALL/LOCATION HISTORY TO PHONE BILL

**[0115] FIG. 70** FLOWCHART OF THE DIRECTIONAL ASSISTANCE NETWORK (DAN) QUERY PROCESS

**[0116] FIG. 71** FLOWCHART OF DAN USER INTERFACE TO RECEIVE DIRECTIONS BY A PHONE NUMBER

**[0117] FIG. 72** FLOWCHART OF DAN USER INTERFACE TO RECEIVE DIRECTIONS BY ANAME

**[0118] FIG. 73** FLOWCHART OF DAN USER INTERFACE TO RECEIVE DIRECTIONS BY A CATEGORY

**[0119] FIG. 74** FLOWCHART OF DAN USER INTERFACE TO RECEIVE DIRECTIONS BY AN ADDRESS

**[0120] FIG. 75** FLOWCHART OF DAN USER INTERFACE TO RECEIVE DIRECTIONS BY FASTEST TRAVEL TIME

**[0121] FIG. 76** FLOWCHART OF DAN USER INTERFACE TO RECEIVE DIRECTIONS BY SHORTEST DISTANCE

**[0122] FIG. 77** FLOWCHART OF DAN USER INTERFACE TO BE CONNECTED TO A SELECTED LISTING

**[0123] FIG. 78** FLOWCHART OF DAN USER INTERFACE TO LOCATE A WCD

**[0124] FIG. 79** FLOWCHART OF DAN USER INTERFACE TO RECEIVE A MAP AND TRAVEL PLANS

**[0125] FIG. 80 TRAFFIC MONITORING AND ROUTING SOFTWARE PROCESS FLOWCHART**

**[0126] FIG. 81 DIRECTIONAL ASSISTANCE NETWORK STRUCTURE**

**[0127] FIG. 82 PRIMARY EMBODIMENT'S LOCATION ON A TYPICAL 2/3G CELLULAR NETWORK**

**[0128] FIG. 83 PRIMARY EMBODIMENT'S ALTERNATE LOCATION ON A TYPICAL 2/3G CELLULAR NETWORK**

**[0129] FIG. 84 PRIMARY EMBODIMENT'S ALTERNATE LOCATION #2 ON A TYPICAL 2/3G CELLULAR NETWORK**

**[0130] FIG. 85 DAN LINKING SOFTWARE**

**[0131] FIG. 86 TRAFFIC TIME CALCULATION PERFORMANCE BASED ON VARIABLE A**

**[0132] FIG. 87 TRAFFIC TIME CALCULATION PERFORMANCE BASED ON VARIABLE TRAFFIC DENSITY RATIO**

**[0133] MASTER LIST OF COMPONENTS**

**100 SECOND GENERATION WIRELESS DEVICE NETWORK**

**102 WIRELESS DEVICE USER**

**104 WIRELESS DEVICE**

**104-A WIRELESS DEVICE**

**104-B WIRELESS DEVICE**

**104-C WIRELESS DEVICE**

**104-D WIRELESS DEVICE**

**106 WIRELESS DEVICE RF SIGNAL**

**108 RADIO TOWER AND BTS WITH GPS RECEIVER NETWORK**  
**110-A RADIO TOWER AND BTS WITH GPS RECEIVER**  
**110-B RADIO TOWER AND BTS WITH GPS RECEIVER.**  
**110-C RADIO TOWER AND BTS WITH GPS RECEIVER**  
**112 GPS SATELLITE NETWORK SIGNAL**  
**114 GPS SATELLITE NETWORK**  
**116 COMMUNICATION LINKS (T1, T3, MICROWAVE LINK, ETC.)**  
**118-A BASE STATION CONTROLLER (BSC) WITH VOCORDING, CIS & BACKHUAL I/F**  
**118-B BASE STATION CONTROLLER (BSC) WITH VOCORDING AND ATMIC**  
**120 VOCORDING**  
**122 CDMA INTERCONNECTION SUBSYSTEM (CIS)**  
**124 BACKHUAL I/F**  
**126 BSS MANAGER**  
**128 INTERSYSTEM LOGICAL CONNECTIONS**  
**130 SWITCH (MTX OR OTHER)**  
**132 INTERSYSTEM LOGICAL CONNECTIONS**  
**134 INTERSYSTEM LOGICAL CONNECTIONS**  
**136 INTERSYSTEM LOGICAL CONNECTIONS**  
**138 PUBLICLY SWITCHED TELEPHONE NETWORK (PSTN)**  
**140 CONNECTION FROM PSTN TO LAND LINES**  
**142 LAND LINES**  
**144 E-MOBILITY SERVICES**  
**148 INTERSYSTEM LOGICAL CONNECTIONS**  
**150 INTERSYSTEM LOGICAL CONNECTIONS**  
**152 SECOND GENERATION SWITCHING STATION**  
**154 INTERWORKING FUNCTION**  
**156 PACKET DATA NETWORK**  
**200 THIRD GENERATION WIRELESS DEVICE NETWORK**  
**202 PACKET DATA SERVICE NODE**  
**204 INTERSYSTEM LOGICAL CONNECTIONS**  
**210 INTERSYSTEM LOGICAL CONNECTION**

212 ATMIC  
300 BASE STATION TRANCEVER SUBSYSTEM (BTS)  
302 GPS RECEIVER  
304 MICROWAVE LINK  
306-A SECTOR ONE PRIMARY RECEIVER ANTENNA  
306-B SECTOR ONE TRANSMIT ANTENNA  
306-C SECTOR ONE DIVERSITY RECEIVER ANTENNA  
308-A SECTOR TWO PRIMARY RECEIVER ANTENNA  
308-B SECTOR TWO TRANSMIT ANTENNA  
308-C SECTOR TWO DIVERSITY RECEIVER ANTENNA  
310-A SECTOR THREE PRIMARY RECEIVER ANTENNA  
310-B SECTOR THREE TRANSMIT ANTENNA  
310-C SECTOR THREE DIVERSITY RECEIVER ANTENNA  
312 RADIO TOWER POLE  
314 ANTENNA LEADS TO BTS  
400 MAIN LOBE AND PRIMARY DIRECTIVITY  
402-A SIDE LOBE  
402-B SIDE LOBE  
404 REAR LOBE  
600-A DISTANCE FROM RADIO TOWER AND BTS WITH GPS RECEIVER 110-A, TO WIRELESS DEVICE 104  
600-B DISTANCE FROM RADIO TOWER AND BTS WITH GPS RECEIVER 110-B, TO WIRELESS DEVICE 104  
600-C DISTANCE FROM RADIO TOWER AND BTS WITH GPS RECEIVER 110-C TO WIRELESS DEVICE 104  
700-A DISTANCE FROM RADIO TOWER AND BTS WITH GPS RECEIVER 110-A, TO WIRELESS DEVICE 104  
700-B DISTANCE FROM RADIO TOWER AND BTS WITH GPS RECEIVER 110-B, TO WIRELESS DEVICE 104  
800-A DISTANCE FROM RADIO TOWER AND BTS WITH GPS RECEIVER 110-A, SECTOR ONE, TO WIRELESS DEVICE 104

**800-B** DISTANCE FROM RADIO TOWER 110-A, SECTOR TWO TO WIRELESS DEVICE  
104

**800-C** DISTANCE FROM RADIO TOWER 110-A, SECTOR THREE TO WIRELESS  
DEVICE 104

**900** USER LOCATION DATABASE

**902** DATABASE LOGIC CENTER

**904** USER LOCATION DATABASE MANAGER

**906** STANDARDIZATION CONVERSION (SOFTWARE/HARDWARE)

**908** USER LOCATION DATABASE COORDINATOR (ULDC)

**910-A** COMMUNICATIONS LINKS (T1, T3, DEDICATED LINES, MICROWAVE LINK,  
ETC.)

**910-B** COMMUNICATIONS LINK (T1, T3, DEDICATED LINES, MICROWAVE LINK,  
ETC.)

**910-C** COMMUNICATIONS LINK (T1, T3, DEDICATED LINES, MICROWAVE LINK,  
ETC.)

**910-D** COMMUNICATIONS LINK (T1, T3, DEDICATED LINES, MICROWAVE LINK,  
ETC.)

**912** INTERSYSTEM LOGICAL CONNECTIONS

**922** INTERSYSTEM LOGICAL CONNECTIONS

**924** INTERSYSTEM LOGICAL CONNECTIONS

**926** INTERSYSTEM LOGICAL CONNECTIONS

**928** INTERSYSTEM LOGICAL CONNECTIONS

**1200** TIMING (TOA, RTD, ETC.)

**1210** SIGNAL STRENGTH MEASURES

**1220** CALL PROCESS INFORMATION

**1230** RADIO TOWER AND BTS LATITUDE/LONGITUDE

**1240** RADIO TOWER ALTITUDE

**1250** RADIO TOWER DOWNTILT

**1260** REGION TYPE OF TOWER (RURAL, URBAN, ETC.)

**1270** CALL PROCESS IDENTIFICATION NUMBER

**1280** HLR/VLR INFORMATION ON CALLER

**1290** AZIMUTH ON SECTORS AND RADIO TOWERS  
**1300-A** SECOND GENERATION WIRELESS NETWORK SERVICE PROVIDER  
**1300-B** SECOND GENERATION WIRELESS NETWORK SERVICE PROVIDER  
**1302-A** THIRD GENERATION WIRELESS NETWORK SERVICE PROVIDER  
**1302-B** THIRD GENERATION WIRELESS NETWORK SERVICE PROVIDER  
**1304** EMERGENCY MEDICAL SERVICES APPLICATIONS  
**1306** COMMUNICATIONS LINK {T1, T3, DEDICATED LINES, SATELLITE, MICROWAVE LINK, ETC.)  
**1500-A** COMMUNICATIONS LINK (DEDICATED LINES, SATELLITE, T1, T3, ETC.)  
**1500-B** COMMUNICATIONS LINK (DEDICATED LINES, SATELLITE, T1, T3, ETC.)  
**1500-C** COMMUNICATIONS LINK (DEDICATED LINES, SATELLITE, T1, T3, ETC.)  
**1500-D** COMMUNICATIONS LINK (DEDICATED LINES, SATELLITE, T1, T3, ETC.)  
**1500-E** COMMUNICATIONS LINK (DEDICATED LINES, SATELLITE, T1, T3, ETC.)  
**1502** PLURALITY OF ULDC'S  
**1506** UPLINK CONNECTION COMPONENT OF THE ULDC  
**1508** SINGLE ULDC HIGHER ON HIERARCHY  
**1510** ULDC ACCESS CONTROL UNIT OF THE ULDC  
**1512** PLURALITY OF ULDC'S  
**1516** REMOTE ACCESS CONTROL UNIT OF THE ULDC  
**1518-A** RF REMOTE LINK  
**1518-B** RF REMOTE LINK  
**1518-C** RF REMOTE LINK  
**1522** DATA LOGGING UNIT OF THE ULDC  
**1524** ULDC CONTROL HARDWARE/SOFTWARE  
**1526** MAINTENANCE UNIT  
**1528** MASTER ULDC AND LOCATION VERIFICATION PROCESS  
**1530** MARKET OR GROUP ULDC  
**1532** MIRROR DATABASE  
**1534** MULTIPLE DOWNLINK CONNECTIONS OF THE ULDC  
**1536** ULDC ACCESS CONTROL UNIT OF THE ULDC  
**1538** UPLINK/DOWNLINK ATM REDUNDANT CONNECTION



**1540** PLURALITY OF REMOTE ACCESS TERMINALS  
**1542** ULDC OR FUTURE EXPANSION REQUIRING ULDC INTERFACE  
**1600** USER LOCATION DATABASE COORDINATOR NETWORK (MARKET BASED SYSTEM)  
**1602** NATIONAL OR INTERNATIONAL ULDC  
**1604** MARKET "A" ULDC  
**1606** MARKET "B" ULDC  
**1608** MARKET "C" ULDC  
**1610** MARKET "D" ULDC  
**1612** MARKET "F" ULDC  
**1614** MARKET "G" ULDC  
**1616** MARKET "H" ULDC  
**1618** OPTIONAL COMMUNICATIONS LINK BETWEEN MARKET ULD'S  
**1620** MARKET "E" ULDC  
**1630-A** COMMUNICATIONS LINK (DEDICATED LINES, SATELITE, T1, T3, ETC)  
**1630-B** COMMUNICATIONS LINK (DEDICATED LINES, SATELITE, T1, T3, ETC)  
**1630-C** COMMUNICATIONS LINK (DEDICATED LINES, SATELITE, T1, T3, ETC)  
**1630-D** COMMUNICATIONS LINK (DEDICATED LINES, SATELITE, T1, T3, ETC)  
**1630-E** COMMUNICATIONS LINK (DEDICATED LINES, SATELITE, T1, T3, ETC)  
**1630-F** COMMUNICATIONS LINK (DEDICATED LINES, SATELITE, T1, T3, ETC)  
**1630-G** COMMUNICATIONS LINK (DEDICATED LINES, SATELITE, T1, T3, ETC)  
**1630-H** COMMUNICATIONS LINK (DEDICATED LINES, SATELITE, T1, T3, ETC)  
**1700** USER LOCATION DATABASE COORDINATOR NETWORK (REGION BASED SYSTEM)  
**1702** DISTRICT "A" ULDC  
**1704** DISTRICT "B" ULDC  
**1706** REGION "A" ULDC  
**1708** REGION "B" ULDC  
**1710** REGION "C" ULDC  
**1712** REGION "D" ULDC

**1714-A** OPTIONAL COMMUNICATIONS LINK (DEDICATED LINES, SATELLITE, T1, T3, ETC)

**1714-B** OPTIONAL COMMUNICATIONS LINK (DEDICATED LINES, SATELLITE, T1, T3, ETC)

**1714-C** OPTIONAL COMMUNICATIONS LINK (DEDICATED LINES, SATELLITE, T1, T3, ETC)

**1714-D** OPTIONAL COMMUNICATIONS LINK (DEDICATED LINES, SATELLITE, T1, T3, ETC)

**1716-A** COMMUNICATIONS LINK (DEDICATED LINES, SATELLITE, T1, T3, ETC)

**1716-B** COMMUNICATIONS LINK (DEDICATED LINES, SATELLITE, T1, T3, ETC)

**1716-C** COMMUNICATIONS LINK (DEDICATED LINES, SATELLITE, T1, T3, ETC)

**1716-D** COMMUNICATIONS LINK (DEDICATED LINES, SATELLITE, T1, T3, ETC)

**1716-E** COMMUNICATIONS LINK (DEDICATED LINES, SATELLITE, T1, T3, ETC)

**1716-F** COMMUNICATIONS LINK (DEDICATED LINES, SATELLITE, T1, T3, ETC)

**1716-G** COMMUNICATIONS LINK (DEDICATED LINES, SATELLITE, T1, T3, ETC)

**1716-H** COMMUNICATIONS LINK (DEDICATED LINES, SATELLITE, T1, T3, ETC)

**1716-I** COMMUNICATIONS LINK (DEDICATED LINES, SATELLITE, T1, T3, ETC)

**1716-J** COMMUNICATIONS LINK (DEDICATED LINES, SATELLITE, T1, T3, ETC)

**1716-K** COMMUNICATIONS LINK (DEDICATED LINES, SATELLITE, T1, T3, ETC)

**1716-L** COMMUNICATIONS LINK (DEDICATED LINES, SATELLITE, T1, T3, ETC)

**1716-M** COMMUNICATIONS LINK (DEDICATED LINES, SATELLITE, T1, T3, ETC)

**1716-N** COMMUNICATIONS LINK (DEDICATED LINES, SATELLITE, T1, T3, ETC)

**1800** USER LOCATION DATABASE COORDINATOR NETWORK (DIRECT SYSTEM)

**1900** REMOTE WIRELESS DEVICE

**1902** WIRELESS COMMUNICATIONS LINK (RADIO FREQUENCY LINK, ETC.)

**1904** PLURALITY OF REMOTE WIRELESS DEVICES

**1906** POLICE

**1908** AUTHORIZED ACCOUNTS AND OTHERS

**1910-A** COMMUNICATIONS LINK (DEDICATED LINES, SATELLITE, T1, T3, ETC.)

**1910-B** COMMUNICATIONS LINK (DEDICATED LINES, SATELLITE, T1, T3, ETC.)

**2300** OMNIDIRECTIONAL TRANSMIT/RECEIVE ANTENNA

2302 ANTENNA LEADS  
2304 TRANSMIT UNIT  
2308 RECEIVE UNIT  
2310 MAINTENANCE UNIT  
2320 TRANSMIT CONTROL UNIT  
2330 RECEIVER CONTROL UNIT  
2340 ULDC INTERFACE CONTROL HARDWARE/SOFTWARE  
2350 RF LINK MANAGEMENT HARDWARE/SOFTWARE  
2360 POWER CONTROL UNIT  
2380 CONNECTION TO EXTERNAL POWER SOURCE  
2410 PCMICA INTERFACE CARD  
2420 CONTROL HARDWARE  
2430 ANTENNA  
2440 DATA CABLE  
2450 TOP COMPUTER  
2460 ANTENNA LEADS  
2470 CONNECTION TO EXTERNAL POWER SOURCE  
1518-A RF REMOTE LINK  
1902 RF REMOTE LINK  
2500 RF REMOTE LINK NETWORK  
2510 DENSE URBAN AREA  
2520 URBAN AREA  
2530 SUB-URBAN AREA  
2605 TRANSMIT UNIT  
2608 RECEIVE UNIT  
2620 TRANSMIT CONTROL UNIT  
2630 RECEIVE CONTROL UNIT  
2640 RF INTERFACE CONTROL HARDWARE/SOFTWARE  
2660 POWER CONTROL UNIT  
2800 NETWORK TUNING SYSTEM/PRIMARY EMBODIMENT  
2802 MONITORING SOFTWARE

**2804 BSC ACCESS CONTROL SOFTWARE**  
**2806 FAULT DIAGNOSIS/CORRECTION SOFTWARE**  
**2808 DEVICE LOCATION SOFTWARE**  
**2810 GEOGRAPHIC INFORMATION DATABASE**  
**2812 CRISS-CROSS PHONEBOOK DATABASE WITH LAT/LONG CORRELATIONS**  
**2814 PRIMARY ANALYTIC SOFTWARE**  
**2816 INTERNAL CENTRAL PROCESSING UNIT AND COMPUTER**  
**2818 INTERNAL MEMORY STORAGE**  
**2820 CASE FILES WITH LAT/LONG**  
**2822 SERVICING EFFECTING FACTORS WITH LAT/LONG CORRELATIONS**  
**2824 RADIO TOWER WITH LAT/LONG CORRELATIONS**  
**2826 USER INTERFACE SOFTWARE**  
**2828 CORRELATING MAPPING SOFTWARE**  
**2830 CORRELATING DATA FOR LAT/LONG INFORMATION**  
**2832 DISPLAY SOFTWARE/HARDWARE**  
**2834 E-MOBILE CONNECTION**  
**2836 DISPLAY SCREEN**  
**2838 LINK REQUIREMENTS FOR SCANNING MODE**  
**2840-A PASSIVE LINKS**  
**2840-B PASSIVE LINKS**  
**2842-A PASSIVE LINK AND/OR ACTIVE LINKS**  
**2842-B PASSIVE LINK AND/OR ACTIVE LINKS**  
**2844-A PASSIVE LINK AND/OR ACTIVE LINKS**  
**2844-B PASSIVE LINK AND/OR ACTIVE LINKS**  
**2844-C PASSIVE LINK AND/OR ACTIVE LINKS**  
**2844-D PASSIVE LINK AND/OR ACTIVE LINKS**  
**2844-E PASSIVE LINK AND/OR ACTIVE LINKS**  
**2844-F PASSIVE LINK AND/OR ACTIVE LINKS**  
**2844-G PASSIVE LINK AND/OR ACTIVE LINKS**  
**2844-H PASSIVE LINK AND/OR ACTIVE LINKS**  
**2844-I PASSIVE LINK AND/OR ACTIVE LINKS**

**2846-A** PASSIVE SCANNING MODE, ACTIVE LINKS  
**2846-B** PASSIVE SCANNING MODE, ACTIVE LINKS  
**2846-C** PASSIVE SCANNING MODE, ACTIVE LINKS  
**2848** USER  
**2900** MASTER SERVER  
**2902** EXTERNAL ACCESS POINT  
**2904** LOCAL ACCESS POINT  
**2906** HIGHSPEED INTERNET GATEWAY  
**2908** WORLD WIDE WEB  
**2910** INDIVIDUAL COMPUTERS  
**2912** CORPORATE EXTERNAL LAN (SECURE)  
**2914** BACK-UP SYSTEM SERVER  
**2916** DATA FLOW DIAGRAM  
**2918-A** DATA FLOW CONNECTIONS  
**2918-B** DATA FLOW CONNECTIONS  
**2918-C** DATA FLOW CONNECTIONS  
**2918-D** DATA FLOW CONNECTIONS  
**2918-E** DATA FLOW CONNECTIONS  
**2918-F** DATA FLOW CONNECTIONS  
**2918-G** DATA FLOW CONNECTIONS  
**2918-H** DATA FLOW CONNECTIONS  
**2920-A** LAN CONNECTIONS  
**2920-B** LAN CONNECTIONS  
**2920-C** LAN CONNECTIONS  
**3000** START (GENERIC COMMAND)  
**3004** PROTOCOL DATABASE  
**3012** RECEIVE DEVICE PROTOCOL LIST  
**3110** COMMAND LIST  
**3200** INTERNET  
**3202** INTERNET  
**3206** LOCAL SERVER/WORK STATION

**3216** USER DATABASE  
**3224** SYSTEM LOG  
**3700** LOCATION OF WIRELESS DEVICE BEING TRACKED  
**3704** FORWARD RECEIVE POWER  
**3706** FORWARD TRANSMIT POWER  
**3708** EC/LO  
**3710** NEIGHBOR LIST  
**3712** MESSAGING  
**3714** FER  
**3716** OTHER ERROR CODES  
**3718** OTHER USER DEFINED FACTORS  
**3720** ERROR CODE  
**3722** CASE FILE #  
**3724** WIRELESS DEVICE ID #  
**3726** OTHER USER DEFINED FACTORS  
**3816** LOCAL ERROR DATABASE  
**3828** TREND ANALYSIS DATA  
**3878** STORED ERROR DATA  
**3886** MESSAGE TABLE  
**3888** CORRECTION TABLE  
**3920** DATA LAYER  
**3926** MASTER DATA LAYER  
**3936** MASTER MAP LAYER  
**3940** FILTERED MASTER DATA LAYER  
**3942** FILTERED DATE LAYER  
**3944** FILTERED MASTER MAPPING LAYER  
**3946** FILTERED MAPPING LAYER  
**3950** PRIMARY DISPLAY LAYER DATA FILE  
**4002** PRIMARY DISPLAY LAYER  
**4004** SECONDARY DISPLAY LAYER

**4100** RADIO TOWER LOCATIONS DISPLAY LAYER  
**4110** WIRELESS DEVICE LOCATIONS DISPLAY LAYER  
**4120** SERVICE AFFECTING FACTORS DISPLAY LAYER  
**4130** ERROR CODES DISPLAY LAYER  
**4140** CRISS-CROSS PHONEBOOK ENTRIES DISPLAY LAYER  
**4150** AUXILIARY OBJECT LOCATIONS DISPLAY LAYER  
**4160** GEOGRAPHIC/TOPOLOGICAL STREET MAP OVERLAY DISPLAY LAYER  
**4170** FINAL DISPLAY OUTPUT  
**5300** LOCATION TRACKING SYSTEM  
**5304** USER NAME AND PASSWORD  
**5306** INTERNAL STORAGE MEMORY  
**5312** USER RECORDS  
**5322** HELP MENU/SERVICE AGENT/OPERATOR  
**5326** MERCHANT CREDIT CARD SERVICES ACCOUNT  
**5400** MEMBERSHIP DATA  
**5420** FAX ON DEMAND  
**5422** POSTAL ADDRESS CONVERSION HARDWARE/SOFTWARE  
**5424** AUTOMATED ANSWERING HARDWARE/SOFTWARE  
**5426** VOICE TEXT READ-UP HARDWARE/SOFTWARE  
**5502** USER CHOICE MENU  
**8100** directional assistance network (DAN)  
**8101** primary logic software  
**8105** voice interface software  
**8110** voice mapping software  
**8115** device location software  
**8120** routing software  
**8125** traffic monitoring software  
**8130** data interface software  
**8135** external DAN query interface software  
**8140** external connections to query device  
**8145** PSTN phone location database

**8150** criss-cross lat/long geographic database  
**8155** geographic database mapping software  
**8160** standardization and conversion software/hardware  
**8165** external network connection  
**8170** computer system  
**8202** wireless communication  
**8205** wireless communication device  
**8212** PSTN/PSTN location database communication interface  
**8220** telephone  
**8222** MTX/PSTN interface  
**8227** MTX/BSC interface  
**8232** BSC/BTS interface  
**8237** MTX/user location database interface  
**8242** MTX/e-mobility services interface  
**8247** MTX/PDN interface  
**8252** PON/internet gateway interface  
**8255** internet gateway  
**8257** internet gateway/internet interface  
**8260** internet  
**8262** a-mobility services/DAN interface  
**8267** MTX/WCD location software interface  
**8270** WCD location software  
**8300** DAN linking software  
**8310** DAN/internet interface  
**8320** a-mobility services/DAN linking software interface  
**8410** DAN/PSTN interface  
**8515** interim linking software  
**8517** interim linking software/packet routing software/hardware interface  
**8520** packet routing software/hardware  
**8522** interim linking software/DAN data query software interface  
**8525** DAN data query software



### **Detailed Description of the Preferred Embodiments**

[0134] Detailed descriptions of the preferred embodiment are provided herein. It is to be understood, however, that the present invention may be embodied in various forms. Therefore, specific details disclosed herein are not to be interpreted as limiting, but rather as a basis for the claims and as a representative basis for teaching one skilled in the art to employ the present invention in virtually any appropriately detailed system, structure or manner.

[0135] Referring to **FIG. 9**, this invention of both a machine and process focuses directly on the ability to use dynamic location based information of a plurality of wireless devices **104** in the form of latitude and longitude, store that data to a dynamic software database user location database (ULD) **900**, via the database logic center **902**, and allow a means by which to share the software database ULD **900** with other entities (either software or hardware). The hardware shown in **FIG. 9** (possibly logically integrated into existing hardware) consists of a ULD **900**, a database logic center (DLC) **902**, a user location database manager (ULDM) **904**, standardization conversion hardware/software **906**, and a user location database coordinator (ULDC) **908**.

[0136] These systems/machines and the software/processes defined within this invention add a unique and novel ability that in its entirety will benefit both business and public as a whole. This benefit will be financially profitable for businesses by allowing the creation of a universal standard that software applications can be developed off of, greatly reducing individual project cost by using this invention as resource. Additionally, as many new wireless software programs are increasingly using location based technology in the form of GPS, this invention would then increase the profitability of companies by using this technology for their software because it is based on existing infrastructure and would not require a consumer, who possesses a wireless device 104, to purchase any additional equipment. This would require less investment by a company using this invention, and increase immediate profit of any hardware/software/firmware applications developed using this invention.

[0137] The fundamental machine is defined by the inclusion of the ULD 900, DLC 902, ULDM 904, standardization conversion hardware/software 906, and ULDC, 908. Basic functions as expanded on in subsequent sections of this invention are as follows:

- ULD 900: Software database for data that includes user entries consisting of a user identifier, latitude and longitude, and other aspects as described in subsequent sections.
- DLC 902 converts data into a storable format for the ULD 900
- ULDM 904: Responsible for reading/writing/appending user entries in the ULD 900 and calculating the data that will be entered into those entries by gathering information from the BSC 118-A and the switch (MTX or other) 130.
- Standardization Conversion Hardware/Software 906 converts data into a standardized format for the ULDC 908.
- ULDC 908: Allows remote access of a singular or plurality of ULD's 1512 by a remote database query.

[0138] The machine and process are compatible with existing 2nd generation wireless device network 100 and future 3rd generation wireless device networks 200. Current wireless networks such as in FIG. 1 are commonly referred to as 2G or second-generation networks 100.

[0139] Still referring to FIG. 9, the components that have been added to the architecture of the second-generation wireless network 100 comprise of the primary embodiments of the machine and process. The ULDM 904 is used for acquiring geographic location data from the BSC 118-A (call processing information/TDOA/RSSI and other data such as predetermined location) and user identifying information (phone number) from the switch (MTX or other) 130.

[0140] It then creates a database entry using the user information {phone number}, date/time information and user controlled settings of a plurality of wireless devices 104 and puts it into the ULD 900 in its software database entry format via the DLC 902. The ULD 900 is a software database resource, containing user entries created by the ULDM 904, for other software/hardware applications such as the shown a-Mobility services 144. The ULDC 908 connects to the switch {MTX or other) 130 and allows remote access to the ULD 900. Logical and physical connections between these physical and logical bodies are illustrated as intersystem

logical connections **922**, **148**, **924**, **926**, **928** and the wired link {T1, or other) **910-A** between the switch {MTX or other) **130** and the ULDC **908**.

[0141] Still referring to **FIG. 9**, also within the scope of this invention, is the ability for location to be determined at the wireless device **104**. This could be accomplished if the device contained a GPS unit itself, or a other means of determining location and could acquire its geographic location {latitude/longitude/altitude/time). In such a case, information would be transmitted back to the switch {MTX or other) **130** by the phone and reported to the ULDM **904**. The location would then be transmitted directly into the DLC **902** (of the ULD **900**), and stored in the ULD **900**. In this case, the wireless device **104** is responsible for the determination of its location. Regardless of where the location at the wireless device **104** is computed, this invention's integrity remains the same. The ability to compute the location at the wireless device **104**, or within the wireless device network **100** or **200** is covered by numerous previous patents.

[0142] Still referring to **FIG. 9**, the data can be sent/received by the e-mobility services **144** or directly to the BSC **206** as data. Location information in this case would be sent continuously or limited by features on the wireless device **104**. Implementation of this method with wireless device **104** having GPS equipment, requires the wireless device **104** to be in relative sight to the sky. The GPS unit would require integration and other procedures to integrate with the wireless device **104**. Other methods (as taught in the prior art) of determining the location of the wireless device **104** at the wireless device **104** may not require the wireless device **104** to be in plain sight or relative to the sky. Regardless, the final results once the longitude/latitude data is sent from the wireless device **104** is the same if the data is calculated at the wireless device **104**, or calculated at the ULDM **904**.

[0143] Still referring to **FIG. 9**, to utilize any calculations of locations at the wireless device **104**, that data will need to be transmitted to the radio towers and BTS **110-A**, **110-B**, and **110-C**, along with voice. Various systems exists to accommodate this including time divided multiple access (TOMA), code divided multiple access (CDMA) and others.

[0144] Beyond the 2G wireless device networks **100** (FIG. 1) exists an emerging technology called 3G (FIG. 2), or third generation (networks) **200**. These wireless networks offer greater features and bandwidth to wireless devices **104** on the network. Integration as shown in FIG. 2 is identical to FIG. 1, or to the 2G wireless device network **100**.

#### **ADDITIONAL EMBODIMENTS**

[0145] Additionally embodiments include a means for a plurality of "e-mobility" services **144** to access the ULD **900** through software (possibly SQL or other similar database query methods). Further included is a means for interfacing directly from the BSS manager **126** to the ULDM **904** for maintenance and direct access of said features.

[0146] Further embodiments include adding to the ULDC **908** a means for redundancy in case of hardware/software failure, using optional input/output capable ports. Additionally, creating a user location database coordinator network (ULDCN) (FIG. 16) **1600**, comprising a means for querying a plurality of user location database coordinators (ULDC's) **1502** and their respective ULD's **1512**.

[0147] A further additional embodiment details a process for querying a plurality of ULDC's **1502** in a programmable order so as to optimize the query results.

[0148] A method also claimed is the hierarchy of user location methods (HULM) that comprises a means for the ULDM **904** to select the most accurate location method from a plurality of location methods, for locating the plurality of wireless devices **104** according to variable conditions which exist within the wireless device network **100**. To ensure consumer privacy, a user control setting comprising a means for a "full" privacy flag (meaning an electronic register indicating the user does not want their phones location information tracked) to be set by a wireless device user **102**, alerts the ULDM **904** if it can record latitude and longitude location data to the ULD **900** for that given wireless device user **102**. An "anonymous" privacy flag allows the location of a wireless device **104** to be monitored on a limited basis, by not reporting the identification information of the wireless device **104**.

[0149] An additional embodiment is the addition of a RF remote link **1518** and remote mobile device **1900**, which can be added to the ULDC **908** in order to allow queries of the ULDC **908** from remote locations. Although the ULDC **908** can be queried by the wireless device **104**, the use of the RF remote link **1518** and remote mobile device **1900** allow queries to be performed on a broader RF band than would be found on the wireless device **104**. This broader RF band allows for more data to be transferred at a greater speed than is possible by a typical wireless device **104**.

#### **ALTERNATIVE EMBODIMENTS**

[0150] Alternate embodiments to the invention include the ability for the hierarchy process for query (HPQ) to be programmed by a designated entity, person, or group in such a way as deemed appropriate by that party to ensure a desired search procedure. Additionally the hierarchy of user location methods used by the ULDM **904** could be modified, appended, reprioritized or otherwise changed to use a plurality of location methods as programmed by a person, group or other entity to obtain any desired level of detail regarding the accuracy of the latitude and longitude calculations.

[0151] Other alternatives include the ability for the privacy flag to be locked in the inactive position by the owner of the wireless device **104**, by remote access, if it is to be used for example, by an employee, a child, a thief or if the wireless device **104** is lost. Having the ability for the privacy flag to be automatically turned in the off position when the user of the wireless device **104** dials emergency services such as for example "911" is also an alternative embodiment. Additionally, the ability for the privacy flag to be turned off by the service provider in the case of, for example, court ordered surveillance. Alternative ways to access the privacy flag are having it be controlled and/or implemented from the wireless device **104** or the BSS manager **126**.

[0152] A further alternative embodiment is transferring acquired geographical data, user information, date/time information, other defined data, and/or user controlled settings information for a plurality of wireless devices **104** containing GPS equipment, or other location means, to the ULDM **904** (from the wireless device itself) and then to the ULD **900**. This also

includes the approach of having the means for the location of the wireless device **104** to be computed at the wireless device **104** and then transmitted to the radio tower and BTS **110-A**, to the BSC **118-A or 118-B**, and then into the ULDM **904** and finally to the ULD **900**.

### **Detailed Description of Drawings With Embodiments**

[0153] Referring to **FIG. 9**, is a typical second-generation (2G) wireless device network **100** architecture similar to that found in **FIG. 1**. However, in **FIG. 9**, some of the embodiments of this invention, which include a ULDM **904** a ULD **900** combined with the database logic center (DLC) **902**, a standardization conversion software/hardware apparatus **906**, and a ULDC **908** have been added. When the wireless device user **102** sends voice or data through the wireless device **104**, the voice and data are sent via a radio frequency signal **106** to the radio tower network **108**. The RF signal **106** from the wireless device **104** is then received by the radio tower and BTS (with GPS receiver network **108**). For illustration purposes, the radio towers and BTS **110-A, 110-B, and 110-C** receive the RF signal **106**. The user's voice and data information, along with other information (described in greater detail in **FIG. 12**) is then sent through a dedicated line (T1, T3, microwave or other dedicated line) **910**, to the base station controller (BSC) **118-A**. Information, which has been gathered from the radio tower and BTS with GPS receiver network **108**, is then dispensed from the BSC **118-A** to the switch (MTX or other) **130** and the ULDM **904**.

[0154] The ULDM **904** then decodes the information that is gathered from the base station controller (SSC) **118-A** and the switch (MTX or other) **130**. It computes the location of a wireless device **104** in accordance with another embodiment of this invention, the hierarchy of user location methods (HULM). The hierarchy of user location methods is a series of changeable and programmable algorithms, which incorporates the appropriate location methods as taught in the prior art. The appropriate method for determining the location of the wireless device **104** would consist of many factors including rural or urban locations of radio towers and other BTS information. Many other factors are covered under the prior art.

[0155] The ULDM 904 then communicates with the DLC 902 through an intersystem logical connection 150. The DLC 902 then stores the decoded data in the ULD 900 in the form of longitude and latitude information, date and time information, user identification information, user selected settings and other factors (as illustrated in FIG. 12). The switch (MTX or other) 130 is simply the place where the ULDC 908 communicates data. The ULDM 904 converts and sends the query via the intersystem logical connection 924, to the ULD 900 through the DLC 902. The ULD 900 then uses its DLC 902 to convert query into internally recognized code and then retrieves it from the entry from the ULD 900. The results are passed back to the DLC 902, which converts the entry back into a format used by the ULDM 904. The entry is passed back through the switch, (MTX or other) 130, to the ULDC 908. This decoded data can also be sent through an intersystem logical connection 922 to e-mobility services 144 where the decoded data can be accessed and used by a plurality of entities and applications.

[0156] Still referring to FIG. 9, these e-mobility services 144 can be accessed by other applications within a single service provider's second-generation wireless device network 100. This networking of ULD's 1512 between service providers and other entities is accomplished through the use of two additional embodiments of this invention, a standardization conversion software/hardware 906 and a ULDC 908. The wireless device 104 can interface with a plurality of applications that are accessed through e-mobility services 144. The wireless device 104 can also query the ULD's 1512 and ULDC's 1502 and use this data for applications within the wireless device 104 or other equipment attached to the wireless device 104. These e-mobility service(s) 144, ULD's 1512 and ULDC's 1502 can also be interfaced via the Internet and the publicly switched telephone network (PSTN) 138.

[0157] The standardization conversion software/hardware 906 is known in the prior arts, however its use in this application is considered to be a point of novelty. The purpose of this device is to facilitate a standardization of the software and hardware transmissions from the service providers second generation wireless device network 100, to device is comprising software and hardware outside of the second generation wireless device network 100. However the standardization conversion software/hardware 906, may not be needed within the second generation wireless device network 100 if it is already operating with a hardware and software

system which is compatible with the interfacing of hardware and software outside of the second generation wireless device network **100**.

**[0158]** In an alternative embodiment the standardization conversion software/hardware **906** is comprised within, or as a peripheral of the device external to the second generation wireless device network **100** such as the ULDC **908**.

**[0159]** As previously stated the ULDC **908**, which is referred to in **FIG. 9**, enables the networking of a plurality of ULD **900** which can be accessed through e-mobility services **144** so as to provide a resource, as an embodiment of this invention, for locating individual wireless devices **104** for such applications as (for example) emergency medical services locating a loss or injured wireless device user **102**, or to assist a wireless device user **102** to locate a loss or stolen wireless device **104**. The ULDC **908**, can also be used, in an alternative embodiment of this invention, as a resource to view and monitor the location of a plurality of wireless devices **104** at the same time, which would be useful in such applications such as (for example) vehicle traffic monitoring so as to enable vehicle trip route planning for emergency medical service vehicles trying to find the fastest route of travel to a particular emergency by avoiding congested traffic areas, or for vehicle trip route planning by individual drivers.

**[0160]** Yet another alternative embodiment of the user ULDC **908** is to provide a resource for monitoring the location of a plurality of selected wireless devices **104** so as to be useful in such applications (for example) as monitoring the location of wireless devices **104** operated by police **1906**, so as to enable faster response time by the police **1906** in an emergency situation, or location of wireless devices **104** operated by taxi services or delivery services in order to improve efficiency, or for businesses to monitor the location of employs.

**[0161]** Now referring to **FIG. 10**, the same embodiments of this invention, as illustrated in **FIG. 9**, are illustrated here in the third-generation wireless device network architecture **200**. These embodiments operate the same as in **FIG. 9**.



[0162] For a third generation wireless device network **200**, the differences involved are minor. Primary operation of the embodiment does not change. However, additional embodiments do exist. The ability to send data at higher rates and to allow faster bi-directional communication between the wireless device **104** and the wireless device network **200** are key. These factors allow the realization of real-time applications to be run from the wireless device **104** that could access various E-mobility services **144** and consequently the ULD **900**.

[0163] Now referring to **FIG. 11**, is a flowchart of tracking wireless device's **104** location. The items of this flowchart, which are numbered from **1100** through **1196**, are intended to demonstrate the current state-of-the-art regarding the processing of a call transmission from a wireless device **104** and are therefore prior art. The items of this flowchart, which are numbered **1100** through **1196**, are unique to this convention and should be considered points of novelty. The call process begins **1100**, when the user originates a call **1105**, and the base-station transceiver subsystem (BTS) **300** receives the call **1105**. Information is then sent from the base station transceivers subsystem to the base station controller (BSC) **1110**, at which point the base station controller **206** establishes resources for the call **1120**. The base station controller **206** checks the switch (MTX or other) **130** database for user information **1125**. The switch {MTX or other) **130** authenticates user information and delivers it to the BSC **1130**. From this point the BSC **206** establishes the call and routes the call to its destination **1135**, through the switch (MTX or other) **130** and then to the publicly switched telephone network **138** or directly to other wireless devices **104** on the wireless network **1135**. The call proceeds **1140**, until the call is terminated **1145**. The BSC **206** then acknowledges the end of the call and tears down the resources **1150** at which point the call process ends **1155**.

[0164] Still referring to **FIG. 11**, the location process runs in parallel with the call and begins when the switch (MTX or other) **130** authenticates user information and delivers the call to the BSC **1130**. It is at this point that the switch (MTX or other) **130** passes the call process identification number **1165** to the ULDM **904**. The ULDM **904**, negotiates with the ULD **900** and sets up the entry **1160**. It is at this point when the ULDM **904**, checks to see if the user has activated the full privacy flag **1170**. The full privacy flag **1170**, is an embodiment of this

invention. The privacy flag **1170**, is intended to allow the user to choose whether or not his/her location can be monitored by the ULDM **904**. If the user has chosen to turn his full privacy flag **1170**, on the ULDM **904**, then logs user inactive **1194** and the ULDM **904**, stops tracking **1196**. If the user has not turned their full privacy flag **1170** on, the BSC retrieves data on the call **1175**. This also applies to when a user may opt to have an 'Anonymous Privacy Flag'. In this case, the user's location can only be accessed by external applications as part of an anonymous location query. In such case, the location of a said user could not be associated with any user information. The difference between the "full privacy" flag and the "anonymous" flag is that the full privacy flag will not let any external program access any data, personal or location information. While, on the other hand, the anonymous flag when set, will allow location-based information to be released, but not personal identifying information. These are both electronic registers that exist in the database entry of the user. The querying software checks them first, to discover the access rights to the user's personal and location-based information.

**[0165]** The ULDM **904**, then computes the location and the location time and date information and other information **1180**, which is acquired from the BSC **206** and the switch (MTX for other) **130**. It then sends the updated data information **1185** to the ULD **900**, via the database logic center **1180**. As the call proceeds, user information is updated **1185**. If the call is still active, the ULDM **904** computes the location and adds location time/date information **1180** and other desired information from the BSC **206** and the switch (MTX or other) **130** and then enters this information into the ULD **900**, via the database logic center **1180**. At this point the user information is updated again **1185**. During this process the e-mobility service **144**, applications have full access to the ULD **900**, which can also be accessed directly by base station subsystem (BSS) **1190**. When the user information is updated **1185** and it is determined that the call is not active **1192**, the ULDM **904**, logs the ULD **900**, entry as inactive **1194** and the ULDM **904**, stops tracking the wireless device **1196**.

**[0166]** Referring to **FIG. 12**, this diagram illustrates in greater detail, the inter-working communication between the base-station controller (BSC) **118-A** or **118-8**, the switch (MTX or other) **130** and the ULDM **904**. The ULDM **904** and the BSC **118-A** or **118-B** are connected by an intersystem logical connection **154**. The ULDM **904** and the switch (MTX or other) **130** are

also connected by an inner system logical connection **152**. The BSC **118-A** or **118-B** and the switch (MTX or other) **130** are connected by an inner system logical connection **132**. A wide variety of information is available to be shared between the ULDM **904**, the BSC **118-A** or **118-B**, and the switch (MTX or other) **130** and can be used in the algorithms of the hierarchy of user location methods. Of these, the items that are most important in determining location, include timing (time difference of arrival (TDOA) and round trip delay (RTD) **1200**, signal strength measurements **1210**, and call processing information **1220**, which are obtained from the BSC **118-A** or **118-B**. In addition, the switch (MTX or other) **130** provides the following information which is used to determine the location, including, radio tower and BTS latitude/longitude **1230**, radio tower altitude **1240**, radio tower down tilt **1250**, region type of tower (rural, urban, etc.) **1260**, call process identification number **1270**, HLRNLR information on caller **1280**, and Azimuth on sectors and radio towers **1290**. However, if a location algorithm of the HULM requires an additional item, they would be available to the ULDM **904**, from the switch (MTX or other) **130**, and BSC **118A** or **118-B**. In an alternative embodiment, location information from the wireless device **104** can also be obtained from the BSC, if the wireless device **104** is equipped with GPS or other location equipment.

[**0167**] Now referring to **FIG. 13**, this diagram illustrates a market level query of the ULDC **908**. This ULDC **908**, is an embodiment of this invention and has been previously illustrated in **FIG. 9** and **FIG. 10**. The ULDC **908**, facilitates the interfacing of a plurality of wireless service providers **1300-A**, **1300-B**, **1302-A** and **1302-B**. In this example of a market level query, the ULDC **908**, is queried by an emergency medical services application **1304**, (for example) for the location of the individual wireless device **104**. In this case a query is sent which is carried through a communications link **1306**, to the ULDC **908**. The ULDC **908**, then evaluates the query using another embodiment of this invention, the hierarchy of process for query (HPQ). The hierarchy of process for query (HPQ) is a changeable and programmable method performing queries within a ULDC **908** or a user location database coordinator network **1600**. It simply instructs the ULDC **908**, on which devices to query for the results of the requested information (query).

[0168] Now referring to **FIG. 14**, is a flowchart, which illustrates a query for information pertaining to a single wireless device **104**. As illustrated, the ULDC **908**, waits for a query **1400**. Then, a remote system (for example, emergency medical services for a service provider) sends a query to the ULDC **908** in the form of a phone number and includes its assigned query ID number **1402**. The ULDC **908**, searches all of the ULD **900**, connected to it, in accordance to the parameters set by the hierarchy process for query (HPQ), for the user entry **1404**. The entry that was requested by the remote system would then be found in a ULD **1406**. The entry information is then sent back to the querying remote system, via the query ID number assigned at the beginning of the process **1408**. The remote system then acknowledges the received data from the ULDC **1410**.

[0169] Now referring to **FIG. 15**, is an illustration of components of the ULDC **908** that has an ATM/direct connection **1500-A** with a plurality of a ULDC **908**, in a hierarchy. **1500-B** connects to the ULDC's **908**, uplink connection **1506**, to higher ULDC **908**. The connection **1500-B** should be dedicated in the sense that interruptions are only when planned for and are expected. Suitable connections are T1, T3, microwave or other similar methods. The ULD **900**, access control unit **1510**, allows interface with a plurality of ULD 's **1512**, having bi-directional connections **1500-C** to each. These connections **1500-C**, are communications links (T1, T3, microwave or other dedicated lines) **1306**. CRC checking and other error checking methods are recommended when implementing the software design in the ULDC **908**, control unit interface.

[0170] Still referring to **FIG. 15**, the remote access control unit (RACU) **1516**, allows dial-up, permanent, or other connections/other external source access to the ULDC **908**. The RACU **1516** has accommodations for a plurality of connection options so-called dial-up or regular phone line connections and will require an internal modem to allow external connections of this type. The speed of the modem should not need to exceed to a 1400kbs per port, although a faster modem could be used. Also accommodations for permanent connections should exist. Data line connection adapters for T1, or other digital sources should be integrated. As specific on this integration prior art, simply their presence as a whole is claimed in this invention as unique. The RF mobile link **1518-A**, could also be connected to the RACU **1516**, via a communications link **1500-D**.

[0171] The data-logging unit **1522**, is responsible for storing/logging queries. It records queries and results from the queries, as well as the user/ID number of the requesting entity to an internal software database. This database should be permanent (but replaceable). A hard drive with the storage capacity of 40 GB should suffice and if it reaches its storage threshold data entries are erased starting ((starting with the oldest first). This storage capacity should allow for up to 1-year worth of entries (if not more) to be reported before old entries are erased.

[0172] Still referring to **FIG. 15**, other components comprised with the ULDC **908**, include; ULDC **908** control hardware/software **1524**, a maintenance unit **1526**, a master ULDM **904** and location verification process **1528**, a market or group ULD **1530**, and a mirror database **1532**. The mirror database **1532**, would mirror connected ULD's **1512**, for faster access to information.

[0173] Still referring to **FIG. 15**, in an alternative embodiment, the ULDC **908**, may comprise a DLC **902**, e-mobility services **144** and standardization conversion hardware/software **906**. This standardization conversion hardware/software **906** would enable the ULDC **908** to be more compatible with hardware/software which is external (for example, service provider, user applications, etc.) to the ULDC **908**. Adding e-mobility services **144** to the ULDC **908** would add efficiency to the query process when the ULDC **908** is asked to query a plurality of locations of wireless devices **104**, from a plurality of service providers comprising a plurality of ULD's **1512**.

[0174] **FIG. 16** shows an illustration of an alternative architecture of a ULDCN **1600**. This alternative architecture illustrates the operation of a market-based system. In this architecture, a remote query, (for example) may be sent by an application comprised within the service providers network, to the service provider's e-mobility services **144**, for the location of a wireless device **104**. If it is determined, by the search of the service providers ULD **900**, that the wireless device **104**, is not operating within the service providers wireless device network **100**, the query would be forwarded from the market level ULDC **908**, via a dedicated communications link **910-A**, and then to a national/international user location database coordinator **1602**, via a dedicated line **1630-A**. This national/international ULDC **1602**, will then query other market level ULDC's

**1604, 1606, 1608, 1610, 1612, 1614, 1616**, in the process specified by the hierarchy process for query (HPQ), for the location of the specified wireless device **104**, which may be roaming outside of its home wireless network **100**. This architecture offers the advantage of easily accessible viewing of market level ULDC's **1502**, on the market level and also on a national/international level **1602**.

[0175] Still referring to **FIG. 16**, another notable embodiment which is illustrated in this architecture is the optional communications link **1618**, between the various market level ULDC **1604, 1606, 1608, 1610, 1620, 1612, 1614, 1616**. These optional communications links **1618**, are notable because it offers two important features; the ability from one market to another without using the national/international level ULDC **1602**, and also as an alternative communications link between the market level ULDCN **1600**, and the national/international level ULDC **1602**, in case there is a break in one or more of the communications links **1630-B, 1630-C, 1630-D, 1630-E, 1630-A, 1630-F, 1630-G, or 1630-H**.

[0176] Now referring to **FIG. 17**, is an illustration of the architecture of a regionally based ULDCN **1700**. Underneath the national/international ULDC **1602**, exists a plurality of district user location database coordinator's **1702 and 1704**, with regional user location database coordinator's **1706, 1708, 1710, and 1712**, and market user location database coordinator's **1604, 1606, 1608, 1610, 1620, 1612, 1614, and 1616**, under them respectively. Service providers **1300-A, 1300-B, 1302-A, and 1302-B**, are positioned below the market user location database coordinators **1620**, mentioned above. Optional communications links **1714-A, 1714-B, 1714-C and 1714-D**, exists between district and regional ULDC's **1502**, in order to provide a more efficient means for routing queries, to provide alternative routing possibilities in case of a communications link break, or to compensate for hardware/software problems within the ULDCN **1700**. Queries within the ULDCN **1700**, are performed in accordance with the hierarchy process of query (HPQ). Queries are routed through communications links, which are permanent connections such as (for example) TI lines 13 lines or microwave links **1716-A, 1716-B, 1716-C, 1716-D, 1716-E, 1716-F, 1716-G, 1716-1-1; 1716-I, 1716-J, 1716-K, 1716-L, 1716-M, 1716-N**. These communications links **1716-A through 1716-N**, represent uplink (From ULD/ULDC) and downlinks (From ULD/ULDC).

[0177] Now referring to **FIG. 18**, a direct system is illustrated for connecting to a user location database coordinator network **1800**. This alternative embodiment illustrates the means for service providers a plurality of wireless network, to query a national/international user location database coordinator **1602** directly. These service providers **1300-A, 1300-B, 1302-A, and 1302-B** are linked to the national/international user application database coordinator **1602** via communications links **910-A, 910-B, 910-C, and 910-0**, which are permanent connections such as (for example) T1 lines T3 lines or microwave links. In an alternative embodiment, the service provider may use an optional communications link **1618** in order to provide an alternative method for routing queries.

[0178] Now examining **FIG. 19**, illustrates the external connectivity for sending queries to the ULDC **908**. A plurality of sources as defined in the embodiments can query the ULDC **908**. Additionally, an RF remote link **1518-A** could be set up that would allow queries from remotely enabled remote wireless devices **1900**, such as laptop computers **2450**, and other devices via a radio frequency (RF) link **1902**. These devices would allow queries to come from a plurality of remote wireless devices **1904**. Queries can also come from services such as police **1906**, emergency medical services **1304** or authorized accounts and other entities **1908**. The queries flow to the ULDC **908** and then to the ULD's **1512** and ULDC's **1502** connected. The ULDC **908** follows the HPQ to collect results from queries.

[0179] Defining the external connectivity for queries of the ULDC **908** is a list of externally connected devices. These devices consist of a plurality of users/devices that can request data from the ULDC **908**. They include:

- A single ULDC higher on the hierarchy **1508**
- A plurality of ULD's **1512**
- A plurality of ULDC's **1502**
- EMS Services **1304**
- RF remote link **1518-A**, and indirectly remote wireless query devices **1904**
- Police **1906**
- Authorized accounts and others **1908**

The ULDC **908** is able to multitask and process these connections simultaneously and can be controlled via software multitasking operations (common knowledge). This allows a large number and complexity of ULD **900** queries to occur simultaneously at the ULDC **908**.

[0180] These devices each connect to the ULDC **908** in different ways. The parallel or lower ULDC's **1502**, and ULD's **1512** are attached connection with dedicated lines, satellite, Ti, T3, microwave, etc. **1500-C** and **1500-A**. The plurality ULDC's **1502** higher in the hierarchy **1508** are connected with a dedicated line, satellite, Ti, T3, microwave, etc. **1500-B** through the uplink port (see FIG. 15) of the ULDC **908**. The remaining devices connect individually through the dialup/fixed connections **1306**, **1500-D**, **1910-A** and **1910-B** to the ULDC **908**. The services using this method are the EMS services **1304**, Police **1906**, RF remote link **1518-A**, and other authorized accounts **1908**.

[0181] Each of the connected devices **1304**, **1518-A**, **1906**, and **1908** using the dialup/fixed connection lines **1306**, **1500-D**, **1910-A**, and **1910-B** would need software to interface with the ULDC **908**. This software is common knowledge by and software engineer to develop. It would consist of a program that would have database query abilities, a graphical user interface, and ways to display and organize queries of the ULDC **908**.

[0182] The RF remote link **1518-A** connected to the ULDC **908** has special requirements. Itself, it cannot submit queries alone to the ULDC **908**. Its primary function is to act as a bridge between the ULDC **908** and wireless device **104**, specifically connected to the RF remote link **1518-A**. It converts signals from land lines **142**, (Ti coaxial, other) into a RF spectrum to be sent to the remote mobile devices **1900** designed for the RF link **1910-C**. Similarly the remote mobile devices **1900** that communicate with the ULDC **908** send SF links **1910-C** back to the ULDC **908**. The RF remote link **1518-A** organizes these signals by users and then converts them to landlines **142**, (Ti ,coax,other) and transmits the signal back to the ULDC **908**.

[0183] The functionality of this RF remote network **2500** (see FIG. 25) is to allow remote mobile devices **1900** in the field to be able to query the ULDC **908** on a secure wireless RF link **1902** connection. The SF spectrum for this FR link **1902** would most likely be between 200MHz



and 10Ghz (or any desired frequency). This frequency would have to, however, be authorized by the FCC for use.

**[0184]** The remote wireless devices **1900** could exist as laptop computers **2450**. They would require an additional piece of hardware with a remote RF transmitter/receiver **1518-A** and an attached antenna **2430**. This hardware could exist as a PCMCIA card with a connection to control hardware and the antenna **2430**. Software control would occur on the laptop computer **2450**, itself. The laptop **2450**, would simply have to have the following minimum requirements:

- Sufficient processor/memory and computing ability to run the query software
- At least one PCMCIA type 1 or 3 slot.
- Ability to function on battery power or other wireless power source
- Ability to power transmitting antenna sufficiently
- Computable software operating system (OS) for query software.

**[0185]** The RF link **1902** would be sent using a secure method such as spread spectrum with frequency hopping. Its signal would be sent as RF signals. The receiving antenna at the RF remote link 1518-A would therefore have to be within the range of the remote wireless devices **1900** signal. It would require a transmit and receive antenna **2430** to send and receive signals from the remote wireless devices **1900**. This antenna **2430** should be an omni directional antenna such as a quarter wave monopole. The range of signals it can send and detect would be a function of the receivers sensitivity and noise rejection ability. The rejection of noise should be greatly increased with the use of a spread spectrum signal.

**[0186]** The benefits of the RF remote link **1518-A** and its connected remote mobile devices **1900** it is a secure way to query the ULDC **908**. The remote wireless devices **1900** could be carried by police **1906**, EMS **1304**, and authorized accounts and other entities **1908** that may need to locate wireless devices **104** and their users **102** for emergencies or for any lawful reason.

**[0187]** **FIG. 20** demonstrates the logic of the hierarchy of location methods. The hierarchy decision algorithm is polled **2000** and the decision process proceeds. First the hierarchy attempts to calculate the location (latitude/longitude) of the mobile wireless device **104**, using the digital

signature method **2010** as covered in prior art. Next it verifies the validity of the result by looking at the RSSI of surrounding towers **2020**. If the guess is valid it allows the result to be saved to the ULD **2060**. If the guess is invalid, the location is calculated based on triangulation and RSSI **2030**. Location is compared to fore mentioned criteria (RSSI) **2040** and if the calculation is approved, the location is saved **2050** to the ULD **900**. If the calculation was incorrect, the location is calculated based on RSSI **2040** only, and stored **2050** to the ULD **900** (least accurate method).

[0188] In **FIG. 20** the HULM is described. It begins when data is sent from the BSC. The first method used is the digital signature method of US Patent # 6249252 or similar. If the selection is validated (as shown in **FIG. 21**) the value is added to the ULD **900** entry. If not, combination method based on triangulation and signal strength is used. If that method is not valid the least accurate method based only on RSSI is used **2050**. **FIG. 27** provides examples of location methods. It should be noted that these location methods are only examples and can be changed or modified in order to accommodate new location techniques.

[0189] **FIG. 21** demonstrates the Compare (validation method in **FIG. 20 (2020, 2040)**) method when validating location. First, the computed value **2100** is passed to the algorithm. It looks at whether all the towers in the range of the wireless device **104** are communicating with the wireless device **104** (and their RSSI) **2110**. Then a test zone is established **2120** that is a large but definitive area based on the towers communicating with the wireless device **104** is computed. The computed (original location) is compared to the test zone **2130**. If the computed value resides within this zone then the location is checked as valid **2160**. If it is not, the next method for location **2150** as shown in **Figure 20** is requested.

[0190] In **FIG. 21** the error check method of the **FIG. 20** is shown. After the value is computed for location, it is checked. All towers first report RSSI of the wireless device **104**. Location zone is then determined in a rough sized area. If the measurement falls within this area then the location is accurate. If not a signal to use the next method is returned. Alternatively, wireless devices **104** comprising location equipment such as, for example, GPS, may also be considered as a source for location information, and evaluated on the accuracy of the location method

utilized at the wireless device **104**.

**[0191] FIG. 22** illustrates e-mobility ULD queries **2200**. E-mobility applications **144** can directly query the local ULD **900** through its DLC **902**. These e-mobility applications **144** can also query remote ULD's **1512** by sending queries through the switch (MTX or other) **130**, through and standardization process **906**, to the upper ULDC's **1502** and consequently to any attached ULD's **1512** or ULDC's **1502**.

**[0192]** When queries are returned they are passed based on the query ID back to the e-mobility applications **144** by passing the result to the ULDC **908**, through any standardization processes **906**, to the switch (MTX or other) **130**, and then back to the original e-mobility application **144**.

**[0193]** In **FIG. 22** the method in which e-mobility applications **144** query remote ULD's **1512** is shown. They first send a query to the ULDC **908** through the switch (MTX or other) **130** connection. The query is then sent to relative ULD's **1512** and ULDC's **1502** based on the HPQ. Results are then forwarded back to the ULDC **908** and to the switch (MTX or other) **130**. At this point the result is then sent to the e-mobility applications **144**.

**[0194] FIG. 23** shows an illustration of the RF remote link **1518-A** components. The ULDC **908** connects to the ULDC interface control hardware/software **2340**. Residing logically or physically in the unit is the RF link management hardware/software **2350** that controls decoding/coding of message queues sent between the wireless query devices **1940** and the ULDC **908**. Next is the power control unit **2360** that powers the RF remote link **1518-A** and its transmit/receive hardware. The maintenance unit **2310** allows for external diagnostics and repair of the unit. The transmit control unit **2320** controls data conversion to RF signals. The receiver control unit **2330** controls conversion of received RF Signals. The transmit unit **2304** amplifies and sends signals to the attached antenna **2300** via coax antenna lead cable **2302**. The receive unit **2308** connects to the antenna and detects and isolates the received signals from the antenna **2300** originating from the wireless query devices.

**[0195]** Now referring to **FIG. 24**, the remote wireless devices can exist as laptop computer **2450**

or any other mobile computing device. They would require an additional piece of control hardware **2420** to control *RF* coding and decoding as well as the ability to function as a RE transmitter/receiver **2420** for an attached antenna **2430**. This hardware could exist as a PCMCIA card **2410** with a connection **2440** to control hardware and the antenna **2460**. Software control would occur on the laptop **2450** itself. The laptop **2450** would simply have to have the following minimum requirements:

- Sufficient processor/memory and computing ability to run the query software
- At least one PCMCIA type 1 or 3 slot.
- Ability to function on battery power or other mobile power source
- Ability to power transmitting antenna sufficiently
- Computable Software operating system (OS) for query software.

The transmitted RF signals **1902** would be sent/received from the RE remote Ink 1518-A that would process queries and send them to the ULDC **908** via a data line **1500-D** (Ti/fixed/or other).

**[0196] FIG. 25** illustrates an RF remote link RF network **2500**. To cover the desired land area, towers should be placed as to target, first, dense urban areas. Ideally one RF remote link tower 1518-A would have coverage for this are. Secondly other antenna **1518-B** and **1518-C** could cover this area. Then coverage for less populated areas such as urban **2520** and the sub-urban **2530** would be covered subsequently. The frequency and separation of towers **1518-A, 1518-B, and 1518-C** in areas such as sub-urban **2530** area need not be as dense because less call/queries from mobile query devices **1900** would occur here. The primary coverage is the dense populated **2510** areas.

**[0197] FIG. 26** illustrates the design of a remote mobile query device **2440**. The primary unit is a laptop computing device **2450** that has the required software for its functionality to send/receive queries to the RF remote link **1518-A**. It then connects via a control card (possibly PCMCIA card interface **2410**) to the RF interface control hardware/software unit **2640**. This unit includes transmit and receive control units **2620, 2630** RF front ends **2605, 2608** and an attached antenna **2430** to communicated via RF signals with the RF remote link **1518-A**. Queries to the

ULDC **908** originate from the wireless query device 1900 and are sent to the ULDC **908** via RF transmissions to the remote RF link **1518-A**.

**[0198] FIG. 27** illustrates to hardware and data that is required by the four recommended methods of location. These methods each require different elements to work appropriately. When deciding which method to use, care should be taken that all elements are available (or substitutes). These elements include: switch (MTX), HLR, VLR, ULD, BSC, SIBS Shelves, BTS, wireless device, timing data, signal strength, call processing information, latitude/longitude of BTS's, radio tower, down tilt, region type, azimuth on sectors, HLR/VLR data. Other location methods may also be utilized. Alternatively, wireless devices 104 comprising location equipment such as, for example, GPS, may also be considered as a source for location information, and evaluated on the accuracy of the location method utilized at the wireless device **104**.

## **OPERATIONS**

### **Call Process—Interaction of Invention**

**[0199]** To make clear the interactions of this invention and how it actually functions, refer to **FIG. 11**. It illustrates what happens when a wireless device 104 makes a call and how it is tracked. The diagram shows each logical function in the process.

Here is the process as described in the **FIG. 11**.

#### *Call originates 1100*

1. ULDM **904** gets user information from the switches user database **1165**.
2. ULDM **904** checks ULD to see if the user already has a previous entry **1160**.
3. If user exists in the ULD, then the records' "log status" flag is turned on **1160**.
4. If user does not exist in ULD **900**, then a new entry is made for the user and flagged (log status) to "on" **1160**.
5. The ULDM **904** now checks the entry for the "private" status of the log **1170** (more specifically, existing entries that have been modified by customer request as private).
6. If the entry is private, then the ULDM flags the entry as "inactive" **1194** and stops monitoring **1196** phone.
7. If log is NOT private, the ULDM **904** accesses the BSC with the call number, processes the ID number and retrieves data on the call **1175**.

8. ULDM **904** decodes data and calculates user's geographical location (latitude/longitude) **1180**.
9. ULDM **904** updates user entry in ULD **900** with geographic information **1185**.
10. ULDM **904** updates ULD **900** entry with the current time and date **1185**.
11. ULDM **904** continues updating ULD **900** entry for user while BSC reports call as active **1185**.
12. When call ends, ULDM **904** flags log as inactive **1194** and stops monitoring **1196** call process ID number in BSC.

**[0200]** Still referring to **FIG. 11**, the user entry is created **1160**. It first checks if the entry exists and then, if not, creates one using the format subsequently described. Now referring to **FIG. 9**, to make this process above work, the ULDM **904** has to gather timing information and other measurements, such as in US Patent #6249252, from the BSC **118-A** to make its calculations. Additionally, it combines this with wireless device **104** and radio tower with **BTS 110-A, 110-B, and 110-C** information acquired from the switch (MIX or other) **130**.

**[0201]** Information gathered from the BSC **118-A** includes:

- Timing (TDOA, RID) information from radio towers **110-A, 110-B, and 110-C** talking to the wireless device **104**.
- Signal strength measurements from radio towers **110-A, 110-B, and 110-C** talking to wireless device **104**.
- Call Processing information in the call control hardware/software of the **BTS**.

**[0202]** Information gathered from the switch (MTX or other) **130** include:

- Directionality of each radio tower **110-A, 110-B, and 110-C** talking to wireless, such as AZIMUTH, DOWTILT, etc.
- Telephone number and call processing ID#.
- Latitude/Longitude/Altitude of the **BTS/Radio Towers 110-A, 110-B, and 110C** talking to the wireless device **104**.

**[0203]** Specifically, the ULDM **904** uses multiple methods (covered in the forementioned

patents) to determine latitude and longitude of a wireless device **104** that involves the gathering of the fore mentioned data. Many major methods as covered under numerous patents have described, in detail, individual methods for acquiring a target location. The most prominent and robust is covered in US Patent # 6249252. As its methodology is quite complex, any individual seeking to understand it should read it in its entirety. However good US Patent #6249252 is, it is recommended that a single method not be relied upon solely. Whereas some methods are good for dense urban terrain (conquering, RF multi-path issues) as in the case of US Patent # 6249252, others are better for suburban type terrain.

**[0204]** The choice in methodology as programmed into the software in the ULDM **904** should be transparent to the effect that based on decision protocols one method or a series of methods should be used in various circumstances automatically.

**[0205]** For dense urban areas with high multi-path, a method such as US Patent #6249252 or #6249680 should be used. These patents deal with high RF multi-path in a dense urban environment. As described in their disclosures, they use digital signatures for key 'reference' locations, allowing a wireless device's geographic location to be acquired with reasonable accuracy.

**[0206]** For suburban, rural or other relatively similar environments, simpler location determining methods should be used. Multi-path RF signals are less of an issue and the suburban methods above are far too complicated and would require a high cost to implement, due to tuning. The recommended method is a simpler TDOA/TOA method such as in US Patent #6167275. These methods often also use receive strength as a function.

**[0207]** Often as the case may be, in practical purposes, one of the location determining methods may still not be enough. In this case a third method based mainly on receive strength could be used (as covered in other available patents). What is unique and should be a part of the location determining software portion of this method, is the decision making process on choosing which method to use is determined.

[0208] As a wireless network is deployed, sectors/antennas are classified as rural, suburban, etc., the decision-making software should first reference this type' and then choose which type of methods to use (US Patent #6249252 or like US Patent #6167275).

[0209] A final check should be to use signal strength (RSSI) to verify/discount an erroneous locations. If the location determined does not correspond to a reasonable value (latitude and longitude plus some degree of error) relative to receive strength, the other primary location determining method should be used to calculate to location.

[0210] The selective use of these two location-determining methods, with a validity check using RSSI of receiving antennas, should ensure a reasonable location.

\*\*Note: If both primary location-determining methods fail to give a reasonable location, a very inaccurate estimate on RSSI could be used.

[0211] The selection of the location determining methodologies used to determine geographic location, and priorities on each, should be selected based on the geographic conditions (terrain, tree density, building density, and other) of the wireless communications network. Therefore, the preceding recommendations could be altered and still remain in the spirit of this invention.

#### **ULD User Entries**

[0212] All entries in the ULD 900 must have a coding standard. The ULDM 904 uses this to create entries in the ULD 900. It is recommended that the following standard coding technique be used for entries, as it is very efficient.

<b><u>Bits (ordered left to</u></b>	<b><u>Data Type</u></b>
0-39	User#
40-103	Location
104-151	Date+Time
152	Log
153	Private
154-167	Spare



**User ID# Format** -----XXX-XXX-XX)(X (10 digit) phone number of user  
4 bits per digit = 40 bits

Bits 0-39 Example: 813-513-8776

Binary----10000001001 10101000100111000011101110110

**Location:**

Bit 40	1=North, 0=South
Bits 41-48	degrees (0-179)
Bits 49-54	minutes (0-59)
Bits 55-60	seconds (0-59)
Bits 61-64	hexiseconds (0-59)
Bits 65	1=West, 0=East
Bits 66-73	degrees (0-179)
Bits 74-79	minutes (0-59)
Bits 80-85	seconds (0-59)
Bits 86-89	hexiseconds (0-15)
Bits 90-103	spare (possibly used to denote accuracy)

Example:           39 degrees 13 minutes 12 seconds 8 hexiseconds North  
                  8 degrees 25 minutes 18 seconds 5 hexiseconds West

**Binary:**

100100111001101 001100100010000100001100101001001010000000000000

HEX: 939A644219494000

**Time & Date:**

Bits 104-108	hour (0-24)
Bits 109-114	minute (0-59)
Bits 115-120	second (0-59)
Bits 121-124	hexiseconds (0-15)
Bits 125-128	month (0-12)
Bits 129-133	day (0-31)
Bits 134-145	year (0-4095)
Bits 146-151	extra

Example: 2248:05 12 hexiseconds 7/18/2001

Binary: 10110110000000101110001111001001111101000100

HEX: B602E3C9F44

**Log Status:** Bit 152 1 =logging

0=not logging

**Full Private:** Bit 153 1=Full private mode

0=not full private

**Anonymous** Bit 154 1 =Anonymous Private

**Private** 0=Not Anonymous Private

**Spare** Bits 154-153 extra for future development/expansion. This area may be designated for future registers for other programs which need to add data tot the users database configuration.

Final data entry formatted value-using values in examples:

HEX: 81351 38776939A64421 9494000B602E3C9F44000

### **Accessing the ULD**

[0213] Repeating this process for every user creates the database on the ULD **900**. This database is now accessible via software three ways:

- The ULDM **904**

ULDM **904** is controlled by the BSS Manager **126**

The BSS Manager **126** can then have access to the ULD **900** through the ULDM **904**.

- E-Mobility services **144** (having read only access to the ULD **900**)

The ULDC **908** connection that allows remote queries (Connects via switch (MTX or other) **130**)

[0214] The first and most direct way to access the ULD **900** is from the BSS manager **126**. This device is allowed read, write, and append access to the ULD **900** via the DLC **902**. It can

perform maintenance (editing entries) and other system level events. Querying the ULD 900 can be developed on the software level by SQL or other database query techniques. This patent does not cover nor intend to limit the creative ability of a programmer in developing ways in which to design the software interfaces. These creative approaches would be within the spirit of the patent, as all software written for this invention would have to be written into existing hardware that has proprietary design. However, it should be noted that this does limit the scope of this patent in any way. It is easily achievable though common approach to a software engineer skilled in the area of database management, to write software that could make direct queries of entries by multiple criteria specified by a user at the BSS manager 126.

[0215] The second method of accessing the ULD 900 is by e-mobility 144 software applications that have read only privileges. These software applications, by means of software SQL statements or other similar database query techniques, access user entries in the ULD 900: Software applications such as these can include features like direction finding software (accessible from the "wireless web") where knowing the wireless devices 104 location is necessary. This type of e-mobility 144 software application is made possible by this unique invention—greatly simplifying the amount of time needed in development of the code because it can use the information in the ULD 900.

[0216] The third method is by a connection to a remote ULDC 908. A ULDC 908 is an important element that should be (but is not required) available in conjunction with any ULD 900 or plurality of ULD's 1512. Its primary function is to allow a plurality of connected devices, which can include ULD's 1512 and additional ULDC's 1502, to be remotely queried (using SQL or any other similar method) by any entity, person or other system connected to the ULDC's 1502 access ports. Uses of this could be for emergency services (911, EMS, etc), government requested "taps" and other purposes where locating a wireless device 104 would be useful.

### **ULDC Architecture**

[0217] FIG. 17 shows a generic representation of the ULDC network (ULDN) 1600. Design can vary, but the general hierarchy is always the same, with ULDC's 1502 having only one parent (a ULDC 908) and having multiple children (either ULDC's 1502 or ULD's 1512) The connections

**910-A, 910-B, 910-C, and 910-D** are dedicated data lines (Ti or other).

**[0218]** The internal diagram of a ULDC **908** is shown in **FIG. 15**. Its components are:

- Direct e-mobility services **144**
- Standardization control hardware/software **906**
- Database logic center **902**
- Uplink connection **1506**
- Multiple downlink connections **1534**
  - ULD access control unit **1536**
  - ULDC access control unit **845**
- Remote access control unit **1516**
- Data logging unit **1522**
- Uplink/downlink optional expansion port **1538**
- Maintenance unit **1526**
- ULDC control hardware/software **1524**
- Master ULDM and location process **1528**
- Mirror database **1532**
- Market or group ULD **1530**

**[0219]** The uplink connection **1506** should only be established with a single ULDC **908** higher in the hierarchy of the ULDCN **1600**. This connection **1500-B** is a 2-way ATM connection carried on a Ti or other similar dedicated line, which allows queries from another ULDC **1508** higher on the network hierarchy. The downlink consists of ULD's **1512** and ULDC's **1502** with can be queried (by SQL or other database query means) directly by the ULDC **908**. There are two access control mechanisms, the ULD access control unit **1510** and the ULDC access control unit **1536**, which control access protocols for each type of query. These two devices negotiate and talk to ULD's **1512** and ULDC's **1502** sending and receiving data between them (queries and responses). The connections should be dedicated lines (Ti or other similar) **1500-A** or **1500-C**.

**[0220]** The remote access control unit **1516** is responsible for negotiating remote hosts **1540**, either by dial-up or a dedicated means of connection, to the ULDC **908** for purposes of database

query submission to obtain geographic location information on wireless devices **104**. These connected devices connect through the remote access control unit **1516** and submit queries to it that then are sent to all connected devices for the search, finally returning the results to the logged on host.

**[0221]** To facilitate the querying process, any connected device should be assigned an ID#. These numbers are so when a query is sent, its original "owner" can be passed with it so the results are passed back to the right entity.

**[0222]** The data logging **1522** unit logs queries and the ID# of the user who made the query, to an internal storage device (internal hard drive or other large data storage device). Lastly, the uplink/downlink optional port **1538** is for future expansions such as redundant connections to other ULDC's **1502** to allow querying laterally in the hierarchy of the ULDC network **1700**, as in FIG. 17. Any alterations for specific needs or for compatibility issues to the ULDC's **1502** architecture are conceded to be within the scope of this invention.

**[0223]** To expedite searches and to give a general flow, the following search method is recommended for the ULDC **908** architecture. Alterations for specific integration needs are within the spirit of the invention.

#### **Searching the ULDC**

**[0224]** Each ULDC **908** should contain data about itself in an internal register that is set when devices are attached to it. Such information includes the area code of all the "home" user entries on its system. "Home" users are users that are listed in the HLR's (home location registrars) of the connected devices. This indicates that users with these area codes have a high probability of being found in certain databases. So, generally the area codes listed could include the area codes of users in the HLR of the switch (MIX's or others) **130** (connected to their respective ULDC's **1512**) that are connected to the ULDC **908**.

**[0225]** Each ULDC **908** contains a list (stored in data register) of all the area codes of all searchable devices attached. These devices could be ULDC's **1512** or even other ULDC's **1502**,

where the list of the ULDC 908 (the ULD's 1512 attached to it) would be added to the other higher ULDC's 502 connected to their uplink ports. In this way any ULDC 908 would have all area codes of the database's HLR's below it in the hierarchy.

[0226] Access ID#'s are assigned to any entity or connection to the ULDC 908 that can submit a query. For example, the uplink connection could be by default #1, the plurality of remote terminals could be #2 or higher. This ID is referenced to all queries so results can be associated with the original owner.

[0227] When a search begins, the ULDC 908 query first searches the "chain" of connected devices FIG. 15 looking first at the ULD's 1512 that contains the area code of the queried entry. If no attached ULD 900 contains the area code, then the ULDC 908 then looks at the ULJIC's 1502 with the area code. Doing so causes a great decrease in search time. This continues on until the ULD 900 with the user entry is found.

[0228] The general flow of a query is in FIG. 14. It begins by the ULDC 908 being in IDLE mode (not being queried) waiting for a query. A logged on device sends a query in the form of a phone number and includes its ID#. The query and ID# are logged to the internal logging database. The ULDC 908 searches all connected devices, then when the result is found, it is returned to the ID# included with the query. The logged on device, or host, then acknowledges the data. At this point the ULDC 908 goes back to idle mode.

[0229] A pseudo-code for a search algorithm may look similar to this. Done in SQL or any similar database query language, this would access the ULDC 908 and search for entries.

*Input Query From Host*

*//check attached devices for area code*

*//descriptor*

*m=(number of attached devices)*

*Let n=0*

*Start n-n+1*

*If attached device n (list of area codes) includes query area code*

*Then go to Find {directly query ULD 900}*  
*Else if  $n=m$  go to end*  
*Else if  $n<m$  go to start*  
*Find (repeat process for all layers of devices)*

\*When this search gets to a ULD 900 it should directly query it. If no entry is found it should continue then by search all devices under the ULDC 908 (queried) in the hierarchy.

### **CONCLUSIONS, RAMIFICATIONS AND SCOPE**

[0230] Possible issues that could arise involve privacy and the concern for misuse/abuse. These issues have been considered while developing this technology, and measures to eliminate these worries are implemented in the device.

[0231] Marking user entries as private can reduce privacy worries. Customer service or any other entities connected to the ULD 900 control software would make the change.

[0232] When the system is told to track a user (when the user communicates with the network on his/her wireless device the ULDM 904 automatically starts) a check by the ULDM 904 is immediately done to see if a "full privacy" flag 1170 has been set. If it is, tracking location of the wireless devices 104 by the ULDM 904 and any modification of the entry in the database does not occur. Using this technology, the system cannot inadvertently track users, and privacy is assured. If an "anonymous privacy" flag is set, location information for a user account can only be retrieved—but no user information will be sent. This can be used by external applications that only require the location of a plurality of devices, without regard to user information. Such an application like the Directional Assistance Network uses this to anonymously find devices on roadways.

[0233] Additional concerns lie in who can access this information. Because all information is stored at the switch (MTX or other) 130 of the network, direct access (and append/write access) to the database can only occur there. This assures that no other wireless device 104 on the network can tamper with this information. Only authorized personnel at the

switch (MTX or other) 130 or persons remotely accessing it through the ULDC 908 have access.

[0234] Results of this database and control system are that a diverse range of software applications can be developed that could access and utilize the database. Emergency services could find users on wireless devices 104 on the network, increasing general public health in medical emergencies when users have a wireless device 104.

[0235] Other "e-mobility" 144 software applications could also access the database giving the users of the wireless device 104 access to services such as direction finding software, location/mapping information and many other portals. The benefit is that this information is controlled and stored by a central entity (the ULD 900 on the network, creating a universal portal that is centrally manageable.

[0236] This technology was previously only available to a limited extent by GPS software. GPS requires that a device have its antenna outdoors or in relatively plain view of the sky to work properly. Cost and bulky sizing are also problems with GPS equipment as compared to cellular mobile devices 104. Additionally, adding GPS to wireless devices 104 would integrate smoothly into this invention. It would simply make it not necessary for location calculations to be done at the ULDM 904. Currently, with an increasing amount of wireless devices 104 connected to wireless (CDMA, TDMA, GSM or other) networks 100, it only seems natural that expanding this technology would benefit the population as a whole.

[0237] While the invention has been described in connection with a preferred embodiment, it is not intended to limit the scope of the invention to the particular form set forth, but on the contrary, it is intended to cover such alternatives, modifications, and equivalents as may be included within the spirit and scope of the invention as defined by the appended claims.

#### **Network Tuning System; Summary of the Invention**

[0238] The present invention is directed generally to a machine and process for calculating and displaying wireless device locations and wireless network service problems with reference to related wireless devices on the said wireless network. The present invention can be referred to as



a display system and a wireless network tuning system (WNTS). This invention uses a method(s) for locating wireless devices and referencing their location and performance with wireless network known parameters. The invention allows more readily accessible representation of wireless device locations on a display screen and problems to be presented to wireless network engineers.

**[0239]** More generally, the present invention is directed to a computational machine and process for displaying wireless device locations, and for detecting and referencing wireless network errors with specific geographical location information of the affected wireless devices. The present invention then can allow a detailed display of the wireless network's problems, and correct the network's problems with a fault diagnosis and correction system. In an additional embodiment, the present invention can provide a means to display other user selected objects including, locations of radio towers and BTS's, service effecting factors, criss-cross phonebook database entries, and a geographic/topographic map overlay. Other customized user-selected objects may be displayed as an auxiliary overlay to the display screen.

**[0240]** In an alternative embodiment, this customized display criteria can be created and viewed by users within the wireless network and to users outside of the wireless network and can act as a resource for other hardware and software which have a need to display locations of wireless devices.

**[0241]** In a second alternative embodiment, the present invention provides a means for generating "case files" which can be customized by a user to provide customized queries when a user has a need for information based on, or relating to, the location of a single wireless device or a plurality of wireless devices. This customized criteria is retrieved in the form of a "case file" that can be created and interfaced by users within the wireless network and to users outside of the wireless network.

**[0242]** The abilities of this invention would be to offer a means of displaying the location of a plurality of wireless devices on a display screen, and to allow wireless network engineers to monitor and debug wireless network problems from the switch (MTX or other) with little or no

actual field testing. Problems recorded in the field could be resolved without delay. The WNTS functions in a basic sense by monitoring the wireless network for problems that affect service to connected wireless devices. When these problems are detected the WNTS can then monitor and track all wireless devices in the problem area and record data on faults and problems these wireless device incur relevant to their latitude/longitude. The WNTS can then correct the problem automatically, or make suggestions to the wireless network engineers for the possible cause of the problem and corrective actions, which may fix the problem.

**[0243]** The most common method to debug these problems is for engineers to go to the field and take limited "snaps shots" of the wireless network that only record data for brief periods of time on limited wireless devices. The process and machine as claimed within, allows a plurality of wireless devices to be monitored and recorded over a period of time, as well as wireless network parameters as they interact with the wireless devices, and additionally record faults these wireless devices incur at specific geographic locations.

**[0244]** To be able to employ the embodiments of this method, process, and machine, you must have the ability to find and locate wireless devices on the wireless network. Also, an additional technology that would allow rapid access to this data would be a dynamic database or system designed to store and hold information including latitude and longitude of the said wireless devices. The ability to determine the user's geographic location in the form of latitude and longitude data is disclosed in an attached document entitled, "A machine for providing a dynamic database of geographic location information for a plurality of wireless communications devices and process for making same". This document referenced above, is a United States Provisional Patent, U.S. Serial Number 60/327,327, which was filed on October 0', 2001. This provisional patent application references the use of user location databases (ULD), user location database coordinators (ULDC), and other location means The use of ULD, ULDC, and other location means is disclosed (offered only as an example of location means) in the fore mentioned provisional patent application, but can also include other means of location including a wireless device comprising a global positioning system (GPS).

**[0245]** The fore mentioned provisional patent provides a system that allows a plurality of

wireless devices on a plurality of wireless networks to have their geographical location as well as other bit, of data stored to easily accessible databases continually.

**[0246]** A system such as this allows a plurality of wireless devices to be tracked, and have their locations stored on a dynamic database for query from a plurality of sources. In an alternate embodiment, the dynamic database could be created and contained within the current invention, and could track and store in memory or a physical database, the geographic location and data of designated wireless devices.

**[0247]** This current invention provides a machine and process with a primary goal to allow a new and novel way to correlate wireless network problems and the manner in which they affect wireless devices on the wireless network and also to provide a trouble shooting system to suggest corrective actions to correct wireless network problems. Such a WNTS would allow a fast and efficient way to optimize a wireless network, without the need for field-testing by wireless network engineers.

**[0248]** In an alternative embodiment, the current invention also offers a means for displaying the geographic location of an individual wireless device or a plurality of wireless devices on a display screen. The ability to display the location of wireless devices on a display screen is a useful and novel feature which can be utilized by other applications which require the ability to view and monitor the location of wireless devices. This alternative embodiment also allows for overlays of a geographic street map display and a criss-cross phonebook display and other user selected displays.

**[0249]** Detailed descriptions of the preferred embodiment are provided herein. It is to be understood, however, that the present invention may be embodied in various forms. Therefore, specific details disclosed herein are not to be interpreted as limiting, but rather as a basis for the claims and as a representative basis for teaching one skilled in the art to employ the present invention in virtually any appropriately detailed system, structure or manner. For example, the components contained within the current invention may reside within the same physical hardware, or the components may reside outside the physical hardware.

### **Detailed Description of the Preferred Embodiment**

[0250] Referring to **FIG. 28** the primary architecture of the embodiments **2800** are illustrated. The main divisions between an existing wireless network **100**, and the primary embodiment **2800** are illustrated. The components in the primary embodiments are:

#### **Elements of the Machine and Process (2800)**

The primary elements of the machine and process include:

- Monitoring software **2802**
- BSC access control software **2804**
- Fault diagnosis and correction software **2806**
- Device location software **2808**
- User location database **900**
- User location database coordinator **908**
- Geographic information database **2810**
- Criss-cross phonebook database with lat/long correlations **2812**
- Standardization/conversion hardware/software **906**
- Primary analytic software **2814**
- Internal central processing unit and computer **2816**
- Internal memory storage **2818**
- Case files with lat/long correlations **2820**
- Service effecting factors with lat/long correlations **2822**
- Radio tower lat/long correlations **2824**
- User interface software **2826**
- Correlating mapping software **2828**
- Correlating data for lat/long information **2830**
- Display software **2832**

[0251] These elements are considered to be the basic requirements for such a system. Additional software and or hardware could easily be added to customize or extend the abilities of this invention (**FIG. 28, Box 2800**) without escaping the limits of its intentions and the spirit of its novelty.

Monitoring Software 2802:

[0252] The monitoring software **2802** is designed to monitor a wireless network 100 for errors or problems that result in service disruption to wireless devices **104-A, 104-B, 104-C, 104-D** within the radio tower network **105**. These errors could result in degradation or even loss of service to the wireless devices **104-A, 104-B, 104-C, 104-D**. The monitoring software **2802** interacts directly with the base station controller (BSC) **118-A** and the primary analytic software **2814**.

[0253] The monitoring software **2802** intercepts and decodes error codes produced by the BSC **118-A** and interprets their effects on the wireless device **104-A, 104-B, 104-C, 104-D**. If the error is service affecting then the fault is sent to the primary analytic software **2814**. The fault monitoring software **2802** acts as an accessory to the primary analytic software **2814**, which is where any interpretations of faults are made.

Base Station Controller (BSC) Access Control Software 2804:

[0254] The base station controller (BSC) access control software **2804** is responsible for interfacing the components and processes of the current invention **2800** with the BSC **2804** of a wireless network **100**. The BSC **2804** contains all the call information as well as all the information on wireless network faults. It should be noted that some wireless network designs have the network fault information stored elsewhere, and that the BSC access control software **2804** could be used to access that information at any other location also. The BSC access control software **2804** interacts directly with the BSC **118-A** and the primary analytic software **2814**.

[0255] The BSC access control software **2804** has the primary function of serving as an intermediary software package that can interlace the current invention **2800** and the BSC **118-A** and switch (MTX or other) **130**.

Fault Diagnosis/Correction Software 2806:

[0256] The fault diagnosis and correction software **2606** is activated when a service-affecting fault is sent from the monitoring software **2802** to the primary analytical software **2814**. When the primary analytical software **2814** receives the fault, the primary analytical software **2814** generates a case file **2820**. The fault diagnosis and correction software **2806** examines the factors

of the case file **2820**, the service effecting factors with lat/long **2822**, the radio tower and BTS with lat/long **2824**, and the geographic information database with lat/long **2910**.

[0257] The fault diagnosis and correction software **2806** comprises a programmable diagnosis and correction system, which can be serviced and updated through a user input device (BSS manager or other) **126**. When a case file **2820** is generated by the primary analytic software **2814**, the possible causes of the fault are determined by matching the data contained in the case file **2820** against a list of possible fault causing factors. Once a number of possible causes for the fault have been isolated, the fault diagnosis and correction software **2806** can then perform diagnostic testing within the wireless network **100** to eliminate false positives, and provide a list of possible causes and corrective actions which may be preformed by the wireless network engineers.

[0258] The fault diagnosis and correction software **2806** can operate in three modes:

- Passive diagnosis mode
- Active diagnosis mode
- Automatic correction mode

The passive diagnosis mode examines contents of the case file **2820**, along with the service effecting factors with lat/long **2822**, the radio tower and BTS with lat/long **2824**, and the geographic information database with lat/long **2810**. Once the circumstances of the fault has been matched against the list of possible fault causing factors, and a list of likely causes and corrective actions are determined and tested, the list possible causes and suggested corrective actions is added to the case file **2820**. When wireless network engineers examine the case file **2820**, they can view the list possible causes and suggested corrective actions generated by the fault diagnosis and correction software **2806**.

[0259] The active diagnosis mode allows network engineers to use the automated diagnostic features of the fault diagnosis and correction software **2806** to automate the diagnosis and correction process. The active diagnosis mode is a completely user definable mode. It allows the user to define certain radio towers with BTS's **110-A**, **110-B**, **110-C**, **110-D**, **110-E**, wireless

devices **104-A, 104-B, 104-C, 104-D**, or other criteria to be monitored for faults. This mode requires actual input from the wireless network engineers and cannot start automatically.

**[0260]** Benefits of this mode would be to monitor problems or areas that would not be triggered in the passive mode, or to monitor problems that are anticipated in advance.

**[0261]** The automatic correction mode can be programmed by the wireless network engineers to operate both in the passive diagnosis mode and the active diagnosis mode. When the automatic correction mode is activated, the fault diagnosis / correction software **2806** is allowed to make adjustments to the wireless network **100** if the result of the fault diagnosis testing prove conclusively (or to a very high probability) that the cause of the fault has been determined and that a determined corrective action will fix the problem. When a corrective action is made in the automatic correction mode, the cause of the fault and corrective action taken are recorded in the case file **2820**.

*Device Location Software 2808:*

**[0262]** The device location software **2808** is the package that when activated by the primary analytic software **2814** is able to retrieve information from a database such as a ULD **900**, or a ULDC **908**, that holds geographic information (as well as time, date of the acquired geographic information). Additionally, as an alternative embodiment this device location software **2808** can directly query the BSC **118-A** and calculate the location of a wireless device **104-A, 104-B, 104-C, 104-D**, as instructed by the primary analytic software **2814**. The device location software **2808** interacts directly with the BSC **118-A**, the primary analytic software **2814**, the ULD **900** and/or ULDC **908**.

**[0263]** The device location software **2808** should be able to be passed queries to return the location of:

- A specific wireless device
- All wireless devices on specific BTS's
- All wireless devices on a plurality of BTS's

The device location software **2808** would directly query a dynamic database as discussed above (ULD **900**, ULDC **908**) to retrieve individual locations for wireless devices **104-A, 104-B, 104-C** or **104-D**. Alternatively, if no ULD **900** or ULDC **908** were available, the device location software **2808** would directly access and decode the BSC **118-A** in order to determine the individual location of the wireless device **104-A, 104-B, 104-C, 104-D**. The device location software can also retrieve the location of wireless devices **104-A, 104-B, 104-C, 104-0**, equipped with a GPS system, or other means of determining geographic location such as triangulation, round trip delay, or other means.

[0264] If a plurality of individual wireless devices **104-A, 104-B, 104-C, and 104-D** were queried, they would all be sequentially resolved by queries to the ULD **900**, the ULDC **908**, device location software **2808**, by direct access and decoding of the BSC **118-A**, or by querying the wireless device **104-A, 104-B, 104-C, 104-D**.

[0265] If a specific radio tower and BTS **110-A, 110-B, 110-C, 110-D, 110-E** (and thus all wireless devices connected **104-A, 104-B, 104-C, 104-D**) is requested. Then the device location software **2808** would first query, by means of the BSC access control software **2804**, the BSC **206** and retrieve information on which wireless devices **104-A, 104-B, 104-C, 104-D** where connected to a given radio tower and BTS **110-A, 110-B, 110-C, 110-D, 110-E**. The results of this action would be to retrieve the ID#'s for all the wireless devices **104-A, 104-B, 104-C, 104-D** connected to any radio tower and BTS **110-A, 110-B, 110-C, 110-D, 110-E**.

[0266] If plurality of radio tower and BTS's **110-A, 110-B, 110-C, 110-D, 110-E** (and thus all wireless devices **104-A, 104-B, 104-C, 104-D** connected to) are requested, then the device location software **2808** would first query, by means of the BSC access control software **2804**, the BSC **118-A** and retrieve information on what wireless devices **104-A, 104-B, 104-C, 104-D** where connected to all given radio towers and BTS's **110-A, 110-B, 110-C, 110-D, 110-E**. The results of this action would be to retrieve the ID#'s for all the wireless devices **104-A, 104-B, 104-C, 104-0**, connected to all requested radio towers and BTS's **110-A, 110-B, 110-C, 110-D, 110-E**.



User Location Database 900:

[0267] A user location database (ULD) **900**, is covered under United States Provisional Patent, U.S. Serial Number 60/327,327, which was filed on October 4<sup>th</sup>, 2001, is an important element of this invention, but is not required. A ULD **900** is a database comprising a means for obtaining and storing the geographical data, user information, date/time information and/or user controlled settings information for the plurality of wireless devices **104-A, 104-B, 104-C, 104-D**. This information can be retrieved through e-mobility services **144** as well as through direct queries of either the BSS manager **126** or ULDC **908**.

[0268] As related to the current invention **2800**, the ULD **900** is accessed through an e-mobility connection **2834** and can then supply location information about wireless devices **104-A, 104-B, 104-C, 104-D** connected to the wireless network **100**. The ULD **900** may physically reside within the current invention **2800** or as an alternative embodiment, may be physically located outside the current invention **2800**, and accessed, for example through e-mobility services **144**. Availability of the entries in the database of wireless devices **104-A, 104-B, 104-C, 104-D** depends on the implementation of the ULD **900** into the switch (MTX or other) **130** architecture, as not to be covered by this Patent. Noted, should be the ability of an e-mobility service **144** to be able to calculate location information by direct query of the BSC **118-A** or using other hardware, and following similar methods in acquiring this data as done by the ULD **900**.

User Location Database Coordinator 908:

[0269] A user location database coordinator (ULDC) **908**, is covered under United States Provisional Patent, U.S. Serial Number 60/327,327, which was filed on October 4<sup>th</sup>, 2001, is an important element that should be (but is not required) available in conjunction with any ULD **900** or plurality of ULD's **1512**. Its primary function is to allow a plurality of connected devices, which can include ULD's **1512** and additional ULDCs **1502**, to be remotely queried (using SQL or any other similar method) by any entity, person or other system connected to the ULDC's **1502** access ports. Uses of this could be for emergency services (911, EMS, etc), government requested "taps" and other purposes where locating a wireless device **104-A, 104-B, 104-C, 104-D** would be useful.

[0270] The current embodiment **2800** can use a ULDC **908** to access information on other switches (MTX or other) **130** or physical devices such to obtain location information not contained in its own database. This is especially important when there may be more than a single switch (MTX or other) **130** in a given geographic area. The usefulness is that a ULDC **908** will integrate a plurality of switch (MTX or other) **130** networks together and for a super network, in which a larger diagnostic area can be established.

Geographic Information Database 2810:

[0271] A geographic information database **2810** is a software database. The geographic information database **2810** can reside physically separate as in part of any other storage media connected to the primary analytic software **2814**. It contains in part or in whole database information on:

- Roadway locations (correlated to latitude/longitude)
- Landmark locations (correlated to latitude/longitude)
  - o Residential locations
  - o Commercial building locations
  - o Railway locations
  - o Other user defined objects
- Topological survey information
  - o Altitude referenced to latitude/longitude
  - o Ground slope
  - o Other topological data (user customizable)
- Location information of wireless network equipment
  - o BTS
  - o BTS repeaters
  - o Other equipment
- Ground clutter
- User defined class of objects

[0272] The geographic information database **2810** is used to implement a layer of geographic information onto a display screen **2836**, which is seen by a user of the current invention **2800**.

When the data from the geographic information database **2810** is combined with factors accumulated by the primary analytic software **2814**, the primary display software **2832** can produce useful and convenient data analysis to a user.

Criss-Cross Phonebook with Lat/Long Database 2812:

[0273] The criss-cross phonebook with latitude and longitude database **2812** enables internal or external applications to request phonebook listings on a cross-referenced basis. The criss-cross phonebook database **2812** comprises the longitude and latitude of listings sorted by names, addresses and phone numbers of residences, businesses, wireless devices, and government agencies, as well as category of goods/services sold (for business listings) and the price and availability of said goods and services. The criss-cross phonebook database **2812** can be queried and cross referenced by name, telephone, street address, category of goods and/or services, availability of product and price of goods/services, latitude and longitude, These requested listings may be overlaid onto the display screen **2836** along with other requested display layers.

[0274] This criss-cross phonebook database **2812** is a novel and useful embodiment to the current invention **2800**, because it would allow a display screen **2836** to display, for example, the location of local area hospitals overlaid on the display screen **2836** with the location of a wireless device **104-A, 104-B, 104-C, 104-D**, and a street map from the geographic information database **2810**. This embodiment would enable a user of a wireless device **104-A, 104-B, 104-C, 104-D** to easily determine their geographic position and the geographic location and direction to the closest hospital. Another example would be that it would enable a police department to monitor the locations of the wireless devices **104-A, 104-B, 104-C, 104-D** used by police officers. When the police department receives a call for police response, the police department would be able to determine which police officer is best able to respond. May other examples exist regarding the usefulness of this embodiment for government, business and private users.

Standardization/Conversion Hardware/Software 906:

[0275] The standardization/conversion hardware/software **906** provides a means to standardize and convert protocols thereby providing standardized and converted protocols. These standardized and converted protocols provide a means for the

elements of the present invention **2800** to interface with elements outside of the present invention **2800**. See **FIG. 30** for flowchart of this embodiment.

*Primary Analytic Software 2814:*

[0276] The primary analytic software **2814** is the actual processing center of the current invention **2800**. The primary analytic software **2814** is where correlations between wireless network problems and the related wireless devices **104-A, 104-B, 104-C, 104-D** occur. The primary analytic software **2814** controls all claimed embodiments as listed in **FIG. 28, Box 2800**. The primary analytic software **2814** connects to the monitoring software **2802**, BSC access control software **2804**, fault diagnosis/correction hardware/software **2806**, device location software **2808**, geographic information database **2810**, criss-cross phonebook database **2812**, standardization/conversion hardware/software **906**, the user interface software **2826** and display software **2832**.

[0277] The primary analytic software **2814** can run in three ways

- Passive scanning mode
- Active scanning mode
- Inactive

[0278] In the passive scanning mode of the primary analytic software **2814** is able to monitor and decode all the wireless network errors received from the monitoring software **2802**. All the errors have been pre-filtered by the monitoring software **2802** and include only service affecting errors.

[0279] A configurable element of the primary analytic software **2814** is the level or specific errors that would be considered for the passive mode. These level or specific errors are user defined by configuring them in the primary analytic software's **2814** configuration file. This method would allow specific errors to be monitored passively without supervision by a network engineer.

[0280] When a valid error occurs, the primary analytic software **2814** begins logging the error to a case file **2820**. Then the primary analytic software **2814** analyzes the case file **2820** and

retrieves the wireless device's **104-A, 104-B, 104-C, 104-D** ID#and additionally retrieves the radio tower and BTS's **110-A, 110-B, 110-C, 110-D, 110-E** involved in the error (or alternatively all the radio towers and BTS's **110-A, 110-B, 110-C, 110-D, 110-E** talking to the wireless devices **104-A, 104-B, 104-C, 104-D**. Using this information, the primary analytic software **2814** knows what area of the radio tower network **108** to monitor.

[**0281**] Now, the device location acquisition software **2802** will be queried by the primary analytic software **2814** to retrieve the identity of the radio tower and BTS **110-A, 110-B, 110-C, 110-D, 110-E** ID#'s that were involved with the error codes in the open case file **2818**. The result of the query will contain the latitude and longitude as well as the time of the error. The primary analytic software **2814** then continually queries the device locatiqn software **2808** with the given radio tower and BTS's **110-A, 110-B, 110-C, 110-D, 110-E** thus monitoring all activity on them. The data recorded to the case file **2820** is:

- Latitude and longitude of wireless devices **104-A, 104-B, 104-C, 104-D** on the radio tower and BTS's **110-A, 110-B, 110-C, 110-D, 110-E**
- Errors codes on the radio tower and BTS's **110-A, 110-B, 110-C, 110-D, 110-E** coded to the wireless devices **104-A, 104-B, 104-C, 104-D** involved
- Service effecting factors for each wireless device **104-A, 104-B, 104-C, 104-D** tracked on the radio tower and BTS's **110-A, 110-B, 110-C, 110-D, 110-E**
  - o Forward receive power (**FIG. 37, BOX 3704**)
  - o Forward transmit power (**FIG. 37, BOX 3706**)
  - o Ec/Io (**FIG. 37, BOX 3708**)
  - o Neighbor lists (**FIG. 37, BOX 3710**)
  - o Other user definable factors (**FIG. 37, BOX 3712**)
- Fault diagnosis and correction software's diagnosis and corrective action recommended and/or taken.
- Radio tower and BTS latilong **2824**

[**0282**] The primary analytic software **2814** continues to update the case file **2820** for a user definable time period. When the time is up the case file **2820** is closed and saved to a hard disk. A message is sent to the user input device **126** (BSS manager or other) **126** alerting that a case

file **2820** has been created and giving the initial error that caused the case file **2820** to be started.

[**0283**] The active scanning mode of the primary analytic software **2814** is a completely user definable mode. It allows the user to define certain radio towers and BTS's **110-A, 110-B, 110-C, 110-0, 110-E**, wireless devices **104-A, 104-B, 104-C, 104-D**, or other criteria to be monitored. This mode requires actual input from the network engineers and cannot start automatically.

[**0284**] Benefits of this mode would be to monitor problems or areas that would not be triggered in the passive mode, or to monitor problems that are anticipated in advance.

*Internal CPU and Computer **2816**:*

[**0285**] The internal CPU and computer **2816** are a user preference based on system demand. They could be part of or even exist as hardware currently in the wireless network **100**. Alternately, new hardware could be supplied that can power and run the current invention's **2800** software. The memory bandwidth and CPU power would have to be server level. RAM should be of the ECC type, and a parallel process architecture would surely result in higher performance.

*Internal Storage **2818**:*

[**0286**] Internal storage **2818** of the current invention's **2800** data can be contained in any hardware realizable data storage unit. This internal storage **2818** unit must have the ability to change its size dynamically or have sufficient size such that expansion or reduction in database size will not exceed the physical storage maximum.

[**0287**] For redundancy a suggested method is to employ a RAID storage system where multiple physical storage units contain the same data. They operate simultaneously to protect the data. If one unit fails then another is still running and can provide the data.

[**0288**] Speed is also an important factor. Additional RAID designs employ striping techniques to increase access time of stored data on the physical storage device. The physical storage devices can be hard-drives, magnetic storage media, or other storage methods commonly available.

[0289] The RAID design would be particularly valuable with regards to the ULD 900 and ULDC 908. The RAID design offers a "mirror" database, thereby limiting the demands created by continues quires to the wireless network 100.

Case Files 2820:

[0290] Still referring to FIG. 28, this diagram also illustrates the translation of a case file 2820. The interaction from the user is initiated in the user interface software 2826. The primary analytic software 2814 then sends a queue to the primary display software 2832 for the requested case file 2820.

[0291] Operating in parallel, the case file 2820 is accessed and data is interpreted by the display software 2832. The lat/long information is calculated and correlated with the recorded data. The correlating mapping software 2828 then brings this information together as shown in FIG. 41 and displays it to the display screen 2836 for the user 2848.

Service Effecting Factors with Lat/Long 2822:

[0292] Factors that can be elected to be contained as part of a case file or simply to be track can contain in part or in whole:

- RF signal parameters
  - o Forward receive power
  - o Forward transmit power
  - o Packet/frame loss (frame error rate)
  - o Signal/noise level
  - o Fading
  - o Other user defined objects
- Call success factors
  - o Dropped calls
  - o Blocked calls
  - o Access failures
  - o Handoff sequences

- Hard hand-offs
  - Soft-hand-offs
  - Inter-system hand-offs
  - Call initiate
  - Call end
  - Other user defined objects
- Messaging
    - BTS forward messaging
    - Mobile acknowledgements
    - BTS reverse messaging
    - Error codes
    - Call process messaging
    - Hand-off messaging
    - Call initialization messaging
    - Call ending messaging
    - Other user defined objects
- Mobile connection type
    - Active – voice
    - Active – data
    - IDLE (paging)
    - Other user defined objects

Radio tower and BTS Information 2824:

**[0293]** Radio tower and BTS **110-A, 110-B, 110-C, 110-D, 110-E** location information should be located in the switch (MTX) 130 as part of current 2G/3G wireless network **100/ 200** information. The following information is copied into the geographic information database **2810** from the radio tower and BTS information **2824:**

- Latitude



- Longitude
- Antenna height
- Azimuth
- Down-tilt
- Beam-width
- Other user defined objects

*User Interface Software 2826:*

[0294] The user interface software **2826** is a simple software package that simply defines the look and feel for interfacing with the said machine and process **2800**. It allows setting to be adjusted, configuration files to be created, and a plurality of other factors to be interfaced with. It also allows a graphical user interface (GUI) to be presented to the user **2848**. It connects to the user input devices (BSS manager or other) **126** and the primary analytic software **2814**. As the step is purely and interface problem and is common knowledge to a software programmer, any method employed here is easily within the scope of this invention,

*Correlated Mapping Software 2828:*

[0295] The correlated mapping software **2828** is a realizable software package that the current invention **2800** uses to integrate information from the user location database **900**, the user location database coordinator **908**, the geographic information database **2810**, the criss-cross phonebook database **2812**, the device location software **2808**, the case files **2820**, the service effecting factors **2822**, the radio tower and BTS's **110-A, 110-B, 110-C, 110-D, 110-E** and other sources as directed by the display software **2832**.

[0296] This correlated mapping software **2828** takes all these factors and visually overlays them as to produce an output containing a complete output to the user. The correlated mapping software **2828** extrapolates locations of the case files **2820** contents over time. The physical display can be programmed by the end user for a plurality of display options. These options can include:

- Service affecting factors **2822** related to individual radio tower and BTS's **110-A, 110-B, 110-C, 110-D, 110-E**

- Case files **2820** data at specific times
- Receive strength over entire case file **2820** plotted geographically
- Individual call messaging and indicated with symbols (ex: square for a drop call placed geographically where the drop occurred.)
- User location database **900** data
- User location database coordinator **908** data
- Geographic information database **2810** data
- Criss-cross phonebook database **2812** data
- Device location software **2808** data
- Other user defined objects **2848**

See **Fig. 39** for flowchart of this embodiment.

*Correlated Data for Lat/Long Information 2830:*

**[0297]** This information is simply the final form of the data before it is processed into the final display output for a user **2848**. It has processed by the correlated mapping software **2828** already.

*Display Software 2832:*

**[0298]** The display software **2832** is where the visual output for a case file **FIG. 41** is generated. When the user input device (BSS manager or other) **126** requests a case file **2820**, the display software 2832 is activated to decode and display a meaningful representation to a person at the console. It connects to the display screen **2836** and the primary analytic software **2814**.

**[0299]** First the display software **2832** generates an error code list that that displays all the case files **2820** and which radio towers and BTS's **110-A, 110-B, 110-C, 110-D, 110-E**, were involved. The display software 2832 then decodes the errors and correlates them to the specific wireless devices **104-A, 104-B, 104-C, 104-D** involved and plots the errors on a map. This map would have to location of wireless devices **104-A, 104-B, 104-C, 104-D** when the error occurred. It also superimposes the network factors it recorded for the wireless device **104-A, 104-B, 104-C, 104-D** for a user defined time, before and after the error occurred.

[0300] Alternately, the latitude and longitude coordinates could be translated. Current common knowledge software packages (example: Street Atlas software) allow latitude and longitude coordinates to be translated into addressing information relative to roads and specific postal addressing. Latitude and longitude coordinates obtained by GPS systems on the wireless device **104-A, 104-B, 104-C, 104-D** or a location retrieved through a ULD **900** or ULDC **908** or similar device would be converted to standard addressing.

[0301] Using this method, the engineer can see every wireless device **104-A, 104-B, 104-C, 104-D** that had problems and generated errors, and look at what happened before the problem, and what the result of the error had on the wireless device **104-A, 104-B, 104-C, 104-D**. The huge benefit is that the actual location that the error occurred can be seen without having to do field-testing. For example, a case file **2820** could show a dropped call for a wireless device **104-A, 104-B, 104-C, 104-D**, and show that the ec/lo increased dramatically before the drop. It would also show exactly where it occurred and include all the network factors at the time of the error.

[0302] This is a very beneficial visual display because the engineer can see a plurality of wireless devices **104-A, 104-B, 104-C, 104-D** that had the same problem and quickly find a solution to the problem.

[0303] Interactions between components in **FIG. 28** are indicated as communications links which are used as passive links **2840-A, 2840-B** in the primary analytic software's **2814** passive scanning mode, active links **2846-A, 2846-B, 2846-C** in the active scanning mode, and passive link and/or active links **2834, 2844-A, 2844-B, 2844-C, 2844-D, 2844-E, 2844-F, 2844-G, 2844-H, 2844-I and 2846-A** in both the passive and active scanning modes. These passive and active links may be T-1 lines, T-3 lines, dedicated lines, intersystem logical connections **132** and/or other, depending on the actual physical configuration and geographic location of the components.

[0304] Other links which are illustrated in **FIG. 28**, and which also act as passive and active links include the 1-1 lines **2844-A, 2844-B, 2844-C, 2844-D and 2844-E**, which connect the

radio towers and BTS's **110-A, 110-B, 110-C, 110-D 110-E** in the radio tower and BTS network **108**, to the BSC **118-A**. The BSC **118-A** is connected to the switch (MTX or other) **130** by an intersystem logical connection **132**. The switch (MTX or other) **130** is connected to the publicly switched telephone network **138** with an intersystem logical connection **150**. The switch (MTX or others) **130** is connected to the e-mobility services **144** by an intersystem logical connection **148**. The intersystem logical connections **132, 150** and **148** can also act as passive and active links for the primary analytic software **2814**.

[0305] Now referring to **FIG. 29** is a description of the physical realization of the preferred embodiment. It shows the way in which the embodiment of the said invention can be realized by the use of its supporting hardware. The software detailed by the said embodiment is contained in the hardware. The hardware is required though for a successful implementation of the embodiment, and should be seen as such.

[0306] Shown also, is a network with a central master server **2900** that contains the preferred embodiment **2800** and all software. Access points to the master server **2900** are:

- External access point **2902**
- E-mobility applications 144
- Local access points 2904
- BSC 118-A

[0307] In **FIG. 29** the external access point **2902** are isolated from the master server **2900** by a hardware firewall. It then connects to a high speed Internet gateway **2906** and then to the worldwide web (Internet) **2908**. From this point, individual computers **2910** or devices are able to route commands to the master server **2900** using this said connectivity. Additional external connectivity is allowed by use of a corporate LAN **2912** being tied directly to the external access point **2902**. This access is NOT via any Internet connection, and is thus a secure connection.

[0308] E-mobility applications **144** may also access the system directly. The e-mobility applications 144 system is tied into the BSC **118-A** and switch **130**, and connects to the wireless devices **104** where the e-mobility applications **144** are interfaced by the user.

[0309] Shown in **FIG. 29** is the local access point **2904** connection, which constitutes any local connection to the network. Of these types (external access **2902**, e-mobility applications **144**, local access point **2904** and BSC **206**) local access points **2904** this is the most secure. The local access point **2904** connection is used for configuration and other administrative activity. Any available command for the said embodiment can be executed here through a local connection.

[0310] Still referring to **FIG. 29** a back-up system server **2914** is also installed and attached to the master server **2900**. All data / software / connections are mirrored using a redundant array of independent disks (RAID) or similar method to add redundancy to protect the operational ability of the said embodiment if the master server **2900** were to fail.

[0311] The fourth type of connection, the BSC **118-A**, is shown in its logical connection to the network. The BSC **118-A** provides a means to access the master server **2900** through the switch **130** and the publicly switched telephone network (PSTN) **138**. The ability to access the master server **215** through the BSC **118-A** can allow for alternate connection means including access from internet **3200** and remote sources connected to the BSC **118-A**. The uses could include data exchange or remote operational commands.

[0312] Still referring to **FIG. 29** is the data flow diagram **2916**, which illustrates the type of connections between the components of the network. These connections include; data flow connections, local area network (LAN) connections, intersystem logical connections.

[0313] Now referring to **FIG. 30** is an illustration of the standardization and conversion hardware and software **906** that may be used to interface the said primary embodiments **2800** with hardware and software, which are external to the primary embodiments **2800**. The standardization and conversion hardware and software **906** are an SISO (single input single output) type control structure, where a single input results in a single output. In this case, a command from one protocol is input, and the correct protocol for the receiving machine is sent (after being converted internally).

[0314] The flow of this process begins by a start command **3000** being sent to the standardization

and conversion hardware and software **906**. The standardization and conversion hardware and software **906** checks the protocol against known types using its internal protocol database **3004**. If there is a match, and the protocol is recognized **3006**, then it checks device attached **3008** and determines (or is pre-configured) the appropriate protocol by checking receive devices protocol **3010** from the receive device protocol list **3012**. it then determines if a conversion can be made **3014**. If it can convert the command, then it is converted **3016**. The command is then sent **3018** to the connected device **3020**. The conversion would end" **3022** at this point, and wait for another command. If any of the decision boxes (**3006, 3014**) are 'no" then a 'protocol error" **3024** is recorded and the recorded "protocol error" **3024** is send back to the sending source.

[**0315**] Still referring to **FIG. 30** the standardization and conversion process operates the same in either direction, from the source to destination or the destination to the source. The standardization and conversion process is bidirectional.

[**0316**] Now referring to **FIG. 31** is an illustration of the BSC access control software **2804**. The BSC access control software **2804** is responsible for negotiating a connection between the primary analytic software **2814** and the BSC **118-A**.

[**0317**] Still referring to **FIG. 31**, the execution of its internal operations begins when the primary analytic software **2814** sends a request **3100** to the BSC **118-A**. The BSC access control software **2804** then interrupts the start-idle state **3102** that the BSC access control software **2804** functions in when in idle mode. The BSC access control software **2804** checks to see if there is a new request **3104** form the primary analytic software **2814**. If there was a new request, then the BSC access control software **2804** sends a command to receive the message **3106** from the primary analytic software **2814**. It then compares the command **3108** to a command list **3110** of convertible commands (converting to BSC **118-A** native commands).

[**0318**] The next step is to check if the command is convertible **3112**. If the command is convertible **3112**, then the command is converted **3114** to the BSC **118-A** native code (or protocol). The message (code) is then sent **3116** to the BSC **118-A**. The system then goes back into the start (idle-wait for response mode) **3102** waiting for a new command or a returned

answer from the BSC **118A**. If however, prior to step **3112** the command was not convertible, then a 'command error" will be sent **3118** to the primary analytic software **2814**, and the system will return to the start (idle-wait for response mode) **3102**. In this case, steps **3114**, **3226**, **206**, **3102** are skipped.

[**0319**] Still referring to **FIG. 32**, if no new command from the primary analytic software **2814** is received **3104**, but a result from the BSC **206** is returned **3118**, then the reverse conversion process begins. The BSC **118-A** native code is converted into primary analytic software **2814** native messaging **3120**. The message is then sent **3122** to the primary analytic software **2814**. If no result was received from the BSC **118-A**, then the system would have returned to the start (idle-wait for response mode) **3102**. If a message was sent back **3122** to the primary analytic software **2814**. The system then also returns to the start (idle-wait for response mode) **3102**.

[**0320**] Now referring to **FIG. 32**, the user interface software **3200** is illustrated. The user interface software **3200** is responsible for interfacing the user with the primary analytical software **2814** and other subsystems. It allows a plurality of connections to be used as interfaces:

- Internet **3202**
- Intranet **3204**
- Other user defined objects **2848**
- Local server/workstation **3206**

[**0321**] When these four types begin to negotiate **3210** with the user interface software **3200**, all protocol and other pure connectivity issues are resolved by commonly known techniques, the standardization / conversion hardware / software **906**, or through standard protocols. The first step is for the user interface software **3200** to obtain the login information **3212** from the user. The user interface software **3200** then compares the user's login information **3214** against an encrypted database containing the user list. The database containing this information is termed the "user database" **3216**. If the user is not authenticated **3218**, then the session is terminated **3220**. If the user is authenticated **3218**, then the user interface software **3200** begins to log the user's activities, including login information **3222** to the system log **3224**.

[0322] Still referring to **FIG. 32**, the user interface software **3200** now determines the access rights **3226** of the users and allows the user to access **3228** the primary analytics software's **2814** features that it is allowed to. The system monitors continually the user's activity **3230** for abnormal usage. If there is abnormal usage **3232** then a message is sent to the system administrator **3234** and the session is closed **3236**. If there was normal usage **3232** then the user may continue to access the system **3228**.

[0323] Again referring to **FIG. 32**, the user interface software **3200** also monitors for the users activity duration and when the user has been idle for more than a set time **3238** then the session is closed **3236**. When the user ends the session **3240** the system logs the normal closure of the connection **3242** to the system log **3224** and closes the connection **3236**.

[0324] Now referring to **FIG. 33** is a description of the device location software **2808**. This device location software **2808** package is used to determine the location of a wireless device **104** connected to a wireless network **100/200** or other similar network to which a wireless device **104** may be connected. The commands **3300** form the primary analytic software **2814** to the device location software **2802** is a command to locate **3302** a wireless device **104**, as well as an identifier such as the phone number **3304** of a wireless device **104**. The device location software "starts" **3306** and receives the phone number **3308** of the wireless device **104**. It then checks the phone number to see if it is valid for tracking. If the number is invalid **3310**, meaning the number is not valid for any traceable device, an error message is sent **3312** to the primary analytic software **2814**. If the number is valid **3310**, then the device location software **2802** first can query (if it is connected to) a ULD **900** for the location **3314**. If the number and location is found **3316**, then the latitude/longitude of the device is retrieved **3318**, and then a message is sent **3320** with the latitude/longitude to the primary analytic software **2814** and then finishes **3322**.

[0325] Still referring to **FIG. 33**, if the number of the wireless device **104** was not found **3316** then it queries **3324** a similar device such as a ULDC **908**. If the number of the wireless device **104** and latitude/longitude location is found **3326**, then the latitude/longitude of the wireless device **104** is retrieved **3318**, and then sent **3320** to the primary analytic software **2814** and then finishes **3322**. If the wireless device **104** location is not found **3326**, then the device location



software **2802** queries the BSC **118-A** for location information **3328** including timing information on the number of the wireless device **104** including all radio tower sectors in use. The device location software **2802** can then compute the latitude and longitude directly **3330** from information derived from the BSC **118-A** and radio tower latitude/longitude database **2824** by using calculation techniques **3332**. These calculation techniques include triangulation of round trip delay (RTD) from network timing information, triangulation from the signal strength and other commonly known locations techniques. Referred to by this patent are location techniques disclosed in the Provisional Patent, U.S. Serial Number 60/327,327 that was filed on October <sup>4th</sup>, 2001.

[**0326**] Still referring to **FIG. 33**, the location of the wireless device **104** may also be retrieved from the BSC **118-A** if the wireless device **104** contains a global positioning system (GPS) that may transmit the wireless device's latitude/longitude to the BSC **118-A** via the "keep alive" signal or other signal from the wireless device **104**. Alternatively the location of the wireless device **104** can be determined at the wireless device **104** using triangulation, or other location techniques. If the wireless device **104** is equipped with a GPS unit, this would be the preferred location technique due to the GPS's inherent accuracy. The latitude/longitude of the device is returned, and then sent to the primary analytic software **2814** and then finishes **3322**.

[**0327**] Now referring to **FIG. 34** is a diagram that illustrates methods, which can be chosen to track and isolate wireless devices **104-A, 104-B, 104-C, 104-D** on a radio tower network **108**. These methods are used by the device location software **2802**. In a generic radio tower network **108**, consisting of a plurality of radio towers with base-station transceiver subsystem (BTS)(s) **110-A, 110-B, 110-C, 110-D, 110-E**, there are three primary ways to track wireless devices **104-A, 104-B, 104-C, 104-D**. These three ways are to specify:

1. BTS

- a. a single BTS (eg. **110-A, 110-B**, etc)
- b. a plurality of BTS's **110-A, 110-B, 110-C, 110-D, 110-E**
- c. all BTS's

2. Sector

- a. a sector on a BTS (eg. **3400-B** or **3400-A**)

- b. a plurality of sectors on BTS's (eg. **3400-A, 3400-B, 3402-A, 3402-B**, etc.)
- c. All Sectors

3. Wireless device

- a. a specific wireless device (eg. **104-A** or **104-B**)
- b. a plurality of wireless devices (eg. **104-A, 104-B, 104-C, 104-D**)
- c. All wireless devices

[0328] Still referring to FIG. 34 , these tracking methods are initiated by the primary analytic software **2814**. The primary analytic software **2814** chooses which method to use based on the user's choice which is interfaced at the user input device (BSS manager or other) **126** and consequently the fault monitoring software and other internal configurations.

[0329] Again referring to **FIG. 34**, examples of tracking would be if the primary analytic software **2814** instructed the device location software **2802** to track wireless devices **104-A, 104-B, 104-C, 104-D** on radio tower and BTS **110**. The result returned would be wireless device **104-B, 104-C**. If the primary analytic software **2814** instructed the device location software **2802** to track wireless devices **104-A, 104-B, 104-C, 104-D** on sector **3400-B** the result would be wireless device **104-A**.

[0330] Now referring to **FIG. 35-A** describes the primary analytic software **2814**. The process used by the primary analytic software "starts" **3000** by initializing the primary analytic software/hardware **2814** along with the operating system **3500**. The primary analytic software **2814** then brings up a main menu **3502** for a user using the display software **2832**. The user can select:

- Active mode
- Inactive mode
- Passive mode
- Display case file
- File management
- Exit program

Still referring to FIG. **35-A**, if the user selects inactive mode **3504** then the system is placed in standby mode **3506** and then goes into an idle state **3508**. The primary analytic software **2814** then waits for mouse movement or input action **3510**. When this occurs (mouse or input action) the system returns to the display menu **3502**.

**[0331]** If the user selects the active mode **3512**, then the system displays the active mode menu **3516**. The user is then prompted with a menu selection for the following:

- Track a single wireless device
- Track a list of wireless devices
- Track wireless device by sector

**[0332]** Again referring to FIG. **35-A**, if the user selects 'track a single wireless device **3518**, then the user is prompted to enter an identifier for the phone such as the number for a wireless device **3520**. The user is then prompted to select a time period to track the wireless device **3522**. The primary analytic software **2814** then will record the data for the given time on the wireless device **3528**. The primary analytic software **2814** utilizes the device location software **2802** to perform this process. The primary analytic software **2814** then records the file to a storage medium and the user is prompted to rename file **3526**. The user is then prompted if they wish to continue tracking /track **3528** another wireless device. If the answer is yes **3528**, the user is brought back to the active menu **3530**. If they chose no **3528**, then the user is brought back to the main menu **3536**.

**[0333]** If the user is in the active mode **3512**, they can also select to "track a list of wireless devices" **3536**. If the user selects yes, they can enter them into a plurality phone numbers of wireless devices **104-A 104-B, 104-C, 104-D** they wish to track **3538**. The user then selects a time period **3522** to track the wireless devices **104**. The primary analytic software **2814** then will record the data for the given time on the wireless device **3524**. The primary analytic software **2814** uses the device location software **2802** to record the data on the given time of the wireless device **104**. It then records the file to a storage medium and the user is prompted to rename the file **3526**. The user is then prompted if they wish to continue tracking /track **3528** another wireless device **104**. If the answer is yes **3528**, the user is brought back to the active menu **3530**.

If they chose no **3528**, then the user is brought back to the main menu **3532**.

[0334] Still referring to **FIG. 35-A**, the user can also select to track wireless devices by sector(s) delineation (choosing sectors track on) **3540**. The user is prompted to enter/select/choose a list of sector(s) to track wireless devices on **3542**. The user then selects a time period **3522** to track the wireless devices. The primary analytic software **2814** then will record the data for the given time on the wireless devices **104** with the selected sectors being tracked **3524**. The primary analytic software **2814** utilizes the device location software **2802** to perform this process. The primary analytic software **2814** then records the file to a storage medium and the user is prompted to rename the file **3526**. The user is the prompted if they wish to continue tracking /track **3528** another wireless device. If the answer is yes **3528**, the user is brought back to the active menu **3530**. If they chose no **3528**, then the user is brought back to the main menu **3532**.

[0335] The user interface software **2826** is used to allow the user it interact with the various processes of the primary analytic software.

#### **Figure 35-B**

[0336] Now referring to **FIG. 35-B**, the user is prompted to select the passive mode at the main menu **3544**. If the user selects the passive mode then the system displays the passive mode menu **3546** using the display software **2832**. The user is prompted to enter the sector/BTS (or list) to track in passive mode **3548**. The primary analytic software **2814** then asks the user to enter (if any) the 'error criteria' and if the auto-correct mode should be enabled **3550**. The software then sends the information **3552** to the fault monitoring software **2802**. When a fault is detected **3554**, then the system creates a case file and prompts the user for a name (if none is entered then a default is used) **3556**. The primary analytic software then sends **3558** the case file to the fault diagnostics/ correction software **2806**.

[0337] If the user enables the 'auto-correction mode' then corrections are received **3560** from the fault diagnosis/correction software **2806**. These corrections, contained within the case file, are then sent **3562** to the BSC via the BSC access control software **2804**. The user can then select to hit the cancel key **3564** and go back to the main menu **3566**, or not hit the cancel key, go back to

the passive mode menu **3568**.

**[0338]** Still referring to **FIG. 35-B**, from the main menu, if the user selects to "display case files" **3570**, the user is forwarded to **FIG. 35-C, BOX 3572**. If the user selects file management **3574**, (via the user interface software **2826**) from the main menu, then a list of case files in the user's storage medium are displayed **3576** via the display software **2832**. The user can select a plurality of case files **3578** via the user interface software **2826**. The user is then prompted to delete **3580** selected case files. If the user selects to delete **3582** a chosen case files, the case files are deleted and returned **3584** to a display of listed case files. If the user selects to rename **3586** chosen case files, the case files are renamed **3588** and the user is returned **3584** to the display of stored case files. If the user selects **3586** to not "rename case files", the user is then prompted to "exit" the system **3588**. If the user selects to "exit" the system **3588**, they are returned **3566** to the main menu. If the user does not choose to "exit" the system **3588**, the user is returned **3584** to the display which lists the stored case files.

**[0339]** Again referring to **FIG. 35-B**, the user can at any point select to "exit program" **3589**, from the main menu, shut down the primary analytic software **3590**, and exit the program **3591**.

**[0340]** Now referring to **FIG. 35-C**, the user can select from the main menu to "display case file". The user is then prompted to select/enter a case file name **3572** (via the user interface software **2826**). Then the user is prompted to enter a list of criteria to display **3592** (via the user interface software **2826**). The case file criterion is then sent to the display package **3593** which includes:

- Correlated mapping software **2828**
- Correlated lat/long information **2830**
- Display software **2832**

**[0341]** Still referring to **FIG. 35-C**, the primary analytic software **2814** then waits until the user information is displayed **3594** and the user exits the display package **3595**. When the user is done with the display package **3595**, the user is asked if they want to modify the parameters displayed **3596** (via the user interface software **2826**). If the user chooses to display and edit parameters

3597, then the user is returned back to enter criteria to display 3598. If the user does not chose to display and edit parameters 3599, then they are returned to the main menu (FIG. 35-A, BOX 3502).

[0342] Now referring to FIG. 36 is a flow chart, which describes the monitoring software. The monitoring software begins by receiving a "start" command 3602 from the primary analytic software 2814, and a list of flagged criteria 3604 from the primary analytic software 2814. The monitoring software then "starts" 3000 by monitoring 3606 the BSCII8-A for new messages. The monitoring software does so by accessing the BSC 118-A. If no new message is received 3608, it continues to monitor the BSC for new messages unless a software interrupt is called. If a new message is received from the BSC 3608, then the new message is compared 3606 to the flagged criteria list. If the new message 3610 is not in the flagged criteria list, then the monitoring software resumes looking for new messages from the BSC 3606.

[0343] Still referring to FIG. 36, if the new message was in the flagged criteria list 3608, then the monitoring software extracts 3612 the "flagged criteria" information from the new message. The monitoring software then decodes 3614 and encodes the flagged criteria data into a case file format. The monitoring software then creates 3616 a customized case file based of the specific flagged criteria. The monitoring software then sends 3618 the case file to the primary analytic software. Following the case file formatting process, the monitoring software then resumes waiting for error messages in the flagged criteria list 3606.

[0344] Now referring to FIG. 37, this diagram illustrates the case file generation process and how a case file 2820 is organized. Information included in case files, and encoded in any industry standard database format includes:

- Case file distinguisher (number) 3722
- Individual wireless device number 3724
- Individual wireless device location 3700
- Error codes of device 3704
  - o Forward receive power 3704
  - o Forward transmit power 3706

- Ec/lo **3708**
- Neighbor list **3710**
- Messaging **3712**
- FER **3714**
- Other error codes **3716**
- Service effecting factors **2822**
- Radio tower latitude/longitude locations **2824**
- Other user defined factors **3718**

[0345] The actual case file **2820** is composed of a software database entry as shown. It would include 'N' number of entries for all wireless devices **104-A, 104-B, 104-C, 104-D** being monitored as requested by the primary analytic software **2814**.

[0346] Still referring to **FIG. 37**, the format of the industry standard database can be determined by a software engineer, but one approach may be to use the logical format shown in case file **2820** illustrated herein. Table column labels referring to the above types of criteria are in the case file **2820** structure. Any deviation or other structure can be considered within the scope of this patent because this format is a less than critical element of the patent.

[0347] Now referring to **FIG. 38-A** is a description of the fault diagnosis/correction software **2806**. The inputs **3800** which are past from the primary analytic software **2814**, and utilized by the fault diagnosis/correction software **2806** include case files **2820**, request correction command **3802**, and protocol command exchange **3804**. The fault diagnosis/correction software **2806** then "starts" **3000** when the case file **2820** is received **3806** and the protocol commands are exchanged **3808** from the primary analytic software **2814** and the fault diagnosis/correction software **2806**. The case file **2820** is then parsed **3810** to extract information from the case file **2820**. The case files **2820** data is then separated and sorted into defined (by input data) categories **3812** and each error and related data is stored as database entries **3814** into the local error database **3816**. The fault diagnosis/correction software **2806** then "starts" to examine the error **3818**. The fault diagnosis/correction software **2806** accesses **3820** the stored case files **2820** (stored in the local error database **3816**) and creates an additional entry based on data for 15 seconds (or a length of

time determined by a network engineer for a particular configuration) prior to the error, including the following data:

- Case file distinguisher (number) **3722**
- Individual wireless device number **3724**
- Individual wireless device location **3700**
- Error codes of device **3720**
  - o Forward receive power **3704**
  - o Forward transmit power **3706**
  - o Ec/Ib **3708**
  - o Neighbor list **3710**
  - o Messaging **3712**
  - o FER **3714**
  - o Other error codes **3716**
- Service effecting factors **2822**
- Radio tower latitude/longitude locations **2824**
- Other user defined factors **3718**

[0348] Still referring to **FIG. 38-A**, the fault diagnosis/correction software **2806** can now proceed to apply standard (common knowledge by engineers in the field) techniques to detect and identify errors by type **3822**. The fault diagnosis/correction software **2806** determines data value trends **3824** for data leading up until the error begins. The trend analysis is then stored **3826** as a trend analysis database entry **3828**.

[0349] Again referring to **FIG. 38-A**, the fault diagnosis/correction software **2806** then examines **3830** the trend analysis database entry **3828** and compares preliminary trend analysis criteria **3832** against patterns' that indicate error types and resolutions. These patterns are unique to networks, and should be programmed by network engineers for specific networks/setups. Default patterns are suggested by the embodiment of this patent in **FIG. 38-B**. These can be modified or appended and stay within the scope of this patent's claims.

[0350] Now referring to **FIG. 38-B**, the resulting patterns/error resulting from calculations (as



described in **FIG. 38-A, BOX 3832**) are compared **3836, 3840, 3844, 3848, 3852** to defined error criteria. The resulting error code/pattern evaluation produces messages that are then sent back **3856** to the primary analytic software **2814**. If the auto-correction mode was enabled by the user **3858**, (correction requested) then the fault diagnosis/correction software **2806** makes corrections based on the error codes/patterns. The shown default corrections are **3860, 3862, 3864, 3866, 3868**.

[0351] Still referring to **FIG. 38-B**, corrections that are a result of the fault diagnosis/correction software's **2806** analysis are then sent **3870** to the primary analytic software **2814** where they are processed. If no correction was requested **3858** (auto-correction mode is off), or if there are no more errors **3872** in the local error database **3874**, then the trend analysis data **3828**, stored error data **3878**, is purged **3876**. If there is another error in the "local error database" **3872**, then the fault diagnosis/correction software **2806** returns to the "start" point **3000** of the error examination process **3884**. If there are more errors **3872**, the system returns back to the idle "start" point **3884** were the fault diagnosis/correction software **2806** waits for new messages to be passed from the primary analytic software **2814**.

[0352] Now referring to **FIG. 38-C** is a description of the default error table **3878**, message table **3886**, and correction table **3888**. These tables are used in **FIG. 38-B** as defaults for the fault diagnosis/correction software **2806**. Additions and modifications can be made to these tables **3878, 3886, 3888** and stay within the scope of this patent. These tables **3878, 3886, 3888**, can be customized depending on the configurations of the wireless network, hardware and software considerations, the parameters set by network engineers, or other considerations which would require customizing the configurations of these tables **3878, 3886, 3888**.

[0353] Now referring to **FIG. 39** is a description of the correlated mapping software **2828** flow. Output **3900** methods supplied by the primary analytic software **2814** include command to display an output **3902**, raw data file with network data (case file) **3904**, and mapping element list **3906**. The mapping element list **3906** contains all the elements (types of data) that the user wants to map.

[0354] The correlated mapping software **2828** now "starts" **3000** by checking if the case file is valid **3808**. If the case file is not valid **3808**, the correlated mapping software **2828** sends an error message to the primary analytic software **2814** and the display software **2832**. If the case file is valid **3908**, the correlated mapping software **2828** reads an element from the case file **3912**. The correlated mapping software **2828** then assigns a reference color code to the data element to be used later for mapping **3914**. The correlated mapping software **2828** then correlates the data to latitude/longitude values where the data was recorded **3916**, and stores the correlated data **3918** to a data layer **3920** in memory. If this is not the last element in the case file **3922**, then the correlated mapping software **2828** returns to read a new element in the case file **3912**, and continues reading new elements until all elements have been read **3922**. When the last element has been processed **3922**, the correlated mapping software **2828** groups data layers into one file **3924**, and stores all the file data to a **3926** master data layer **3920** file as a database entry.

[0355] Still referring to **FIG. 39**, the correlated mapping software **2828** then calculates the most extreme west/east/north/south points in the data layer **3928**. The correlated mapping software **2828** then imports **3930** maps **2810**, **2812**, **2824**, **3956** based on these extremes. The correlated mapping software **2828** then saves each of these new maps as an individual layer **3932**. The correlated mapping software **2828** follows by grouping these maps to one data file containing all the layers **3934** and stores them in the master map layer **3936**. Based on the requirements of the mapping element list **3906**, the correlated mapping software **2828** filters the case file data and map layers **3938** so that the resulting data contains only data and map layers **3938** relevant to what needs to be mapped. The filtered data **3942** is saved to the filtered master data layer **3940** and filtered mapping layers **3946** are saved to the filtered master mapping layer **3944**. Both the filtered data layer **3942** and the filtered mapping layers **3946** are combined into the primary display layer data file **3950**. The correlated mapping software **2828** records time and date of data and other configurable information and saved into a secondary data file **3948**. The primary display layer data file **3950** and the secondary data file **3948** are then sent to the primary display software **3952**. The correlated mapping software **2828** now closes itself and purges temporary data **3954**.

[0356] Now referring to **FIG. 40** is description of the display software's operations. The display

software's inputs **4000** are the primary display layer **4002**, the secondary display layer **4004**, and command/info passed to the display software **2832** from the primary analytic software **2814**. The display software **2832** "starts" **3000** by sending the primary display layer **4002** and secondary display layers **4004** to two sub routines.

[0357] Still referring to **FIG. 40**, the primary display layer's **4002** subroutine begins **4006** by reading data from the primary display layer **4002** data file data file. The display software **2832** then checks if the output for the user is defined as full screen **4008**. If the output is a full screen **4008**, as defined in the set-up, the display software **2832** then calculates dimensions for the screen size **4012/4016/4020** for full screen operation. If the output is a "window" screen **4008**, as defined in the set-up, the display software **2832** then calculates dimensions for the screen size **4010/4014/4018** for the window screen operation. The display software **2832** then sends the results **4022** to commonly used/known mapping software **2828**. If this is not the last data layer 4024, the system reads the next layer in **4006** and continues as before.

[0358] Again referring to **FIG. 40**, the secondary subroutine starts **3000** by reading data **4026** from the secondary data file. The display software **2832** checks if the output is defined as full screen **4028**. The display software **2832** then calculates dimensions for the screen size **4032/4036/4040** for full screen operation. If the output is defined as window screen **4028**, the display software **2832** then calculates dimensions for the window screen size **4030/4034/4038** for window screen operation. The display software **2832** sends the results **4024** to commonly used/known mapping software **2828**. If this is not the last secondary data layer, the system reads the next layer in **4006** and continues as before. After both subroutines are finished, the display software **2832** outputs the graphic display to the screen **4046/4048** using commonly known techniques.

[0359] Now referring to **FIG. 41** is a description of the final display output format. The final display has seven or more layers. These layers are:

- Radio tower locations display layer **4100**
- Wireless device locations display layer **4110**
- Service affecting factors (mapped to locations) display layer **4120**

- Error codes (mapped to locations) display layer **4130**
- Criss-cross phonebook entries (i.e. landmarks such as buildings) display layer **4140**
- Auxiliary object locations display layer **4150**
- Geographic/topological street map overlay display layer **4160**

[0360] The final display output is the sum of the above display layers. A plurality of auxiliary object location display layers may be added by the user via the user interface software. By doing so, the user may expand the mapping and display features of the resulting maps.

[0361] Still referring to **FIG. 41**, layer one 4100 is the location (latitude and longitude) of all the radio towers and BTS's **110-A, 110-B, 110-C, 110-D, 110-E** in the radio tower and BTS network **108**.

[0362] Layer two **4110** overlays the latitude/longitude of the wireless devices **104-A, 104-B, 104-C, 104-D** (and the previous locations relative to time) of the wireless devices **104-A, 104-B, 104-C, 104-D**.

[0363] Layer three **4120** plots the service effecting factors in the case file based on the recorded latitude and longitude where the factors **4121, 4122, 4124, 4126, 4128** were recorded.

[0364] Layer four **4130** plots the error codes in the case file based on the recorded latitude and longitude where the factors **4132, 4134, 4136** were recorded.

[0365] Layer five 4140 plots selected entries from the criss-cross phonebook database with lat/long correlations. The displayed entries **4142, 4144 and 4146** could represent such entries as, for example, hospitals, gas stations, restaurants, or a private residence.

[0366] Layer six **4150** plots auxiliary lat/long correlations of user selected/inputted entities **4152, 4154, 4156**.

[0367] Layer seven **4160** overlays a topographic map with road locations with correlated to their actual latitude and longitude locations.

[0368] Still referring to **FIG. 41**, the final display output **4170** is sent to the user and shows all layers above combined together.

### **Alternative Embodiments**

[0369] Now referring to **FIG. 28**, two alternative embodiments are contained within the current invention. The first alternative embodiment provides a means for providing a display screen machine and process, which enables access to the current invention by other applications through e-mobility services **144** or other interfaces. This alternative embodiment could be used by other applications which have a need to display the geographic location of wireless devices **104-A, 104-B, 104-C, 104-D**, geographic location of entries contained with the crisscross phonebook database **2812**, maps of or other data contained within the geographic information database **2810**, user selected auxiliary entries, or other entries contained within the current invention **2800**. The primary elements required by this first alternative embodiment include:

- Expansion to current embodiment to allow external queries to be processed (e-mobility services **144**)
- Alternative Embodiment Requirements
  - o a BSC access control software **2804** and/or a user location database **900** or user location database coordinator **908**
  - o Monitoring software **2802**
  - o Device location software **2808**
  - o Geographic information database **2810**
  - o Criss-cross phonebook with lat/long database **2812**
  - o Standardization/conversion hardware/software **906**
  - o Primary analytic software **2814**
  - o Internal CPU and computer **2816**
  - o Internal storage **2818**
  - o User interface software **2826**
  - o Correlated mapping software **2828**

- Correlated data for lat/long information **2830**
- Display software **2832**
- Inner system logical connection and other connections **132**

The primary external queries will initiate from the e-mobility services **144** of a wireless network **100**. This implementation greatly reduces the necessity for excessive amounts of integration to occur.

[0370] E-mobility services **144** already in current wireless networks **100** have access to the internet though certain firewall, LAN routing, and data protection schemes. This can be exploited by allowing external software to query, using a secure data connection via the internet, the said first alternative embodiment. All calculations, and processing would occur at the wireless networks server.

Access to this data would be limited by defined settings such as.

- Viewable layers in final output
  - Topological data
  - Roadways
  - Location of wireless devices
  - Criss-cross phonebook data
  - Geographic information data
  - Other user defined data
- Service affecting factors
  - Receive strength
  - Signal to noise ratio
  - Other user defined data
- Location and or previous location of the wireless device
  - ULD database tracking
  - ULDC queries to track mobile
  - Other user defined data
- Types of queries
  - Individual wireless device **104**

- Sector of BTS
- BTS
- Network
- ULD **900**
- ULDC **908**
- Device location software **2802**
- Other user defined queries
- Amount of time until processing occurs
- Level of precision in latitude and longitude
- Multiple query submission
  - Have a predefined list of criteria to be submitted at regular intervals to the system
  - Have reports automatically generated and sent through E-mobility applications **144** back to Internet user.
- Ability to report System errors
  - Internet connected user can report false information reported by the system.
  - Internet connected user can report missing information reported by the system.
  - Other user defined objects **2848**

### **External Connectivity of Preferred Embodiment**

**[0371]** Now referring to **FIG. 29**, the physical realization of the preferred embodiment and the alternative embodiments is illustrated. These embodiments include a plurality of methods to develop case files and hence detailed information on users/conditions that exist on a wireless network **100**. When these case files are generated they are stored on the server—which is located at the switch (MTX or other) **130**. This allows rapid use of these case files for debugging and optimization.

**[0372]** The wireless network **100** can however be accessed from access points other than the switch **130**. These locations are the corporate LAN **2912** and the Internet **3202**. Both connections offer secure connections. Examples of secure connections would be secure server language (SSL) and other similar connections.

[0373] Still referring to **FIG. 29**, the ability to access the switch (MIX or other) **130** from an external software package is integrated into the preferred embodiments. These preferred embodiments allows a plurality of software packages to access the databases and primary analytic software **2814** contained within these embodiments. These external software packages can be assigned certain security allowances in addition to individual user privileges. These restrictions would be able to limit software packages that the wireless network **100** has not authorized to various levels of access.

[0374] An example of third-party *I* remote internet **3202** access programs could be a program that a wireless service provider uses to integrate billing information with communications (call, page, text message, etc.) logs. The wireless service provider could set up a location information program that could be marketed to users as a way to access location information regarding communications made on their wireless devices **104** billing statement. This location information program could be accessed by users, allowing them to remotely access the preferred embodiments and initiate a continuous tacking ability on the wireless device **104**, when communications are made or at any other time. A user could also retrieve location information from a web site on the Internet **3202** for any communication (call, page, text message, etc.) on his wireless device bill, for example, thereby allowing the user to access a log of the geographic location information correlated to the user's logged communications. This would allow an employer to monitor the locations of employees at the time communication are sent and received.

[0375] Another example would be for a program issued to police or law enforcement agencies to track a list, of a plurality of wireless devices **104** that could be submitted over the Internet **3202**. This list would get updated at the switch (MTX or other) **130** in the users account and allow case files to be generated on the list of wireless devices **104** the user submitted.

[0376] There are many possible ways to use this external connectivity option, however any use of its features would be considered within the realm of this patent's legal claims.

[0377] The primary elements (access of many options could be defined by access rights of



user/connection type) of this external connectivity would be the following:

- Ability to negotiate a secure connection via the internet **3202**/corporate LAN **2912**
- Ability to authenticate software package and user
- Ability to negotiate commands to create a new user account with the preferred embodiment for the said new user. This account would contain profile, preferences, and storage ability for case files generated for the user.
- Ability to send a list of wireless device identifications **3726** (phone #s, ESN's, etc) of mobile devices that would allow the preferred embodiment to track these items.
- Ability to set tracking modes for the list of identified mobiles that are submitted to the said embodiment. These modes are: Manual (one time tracking only) and automatic (track and record mobile devices for a said period of time at any given interval. These intervals can include time of day, time of call (when the mobile makes a call), and default settings (every 24 hours).
- The ability to submit criteria for tracking other than a unique identifier phone a said wireless device **104**. This can include:
  - o Geographic criteria (track—create case files—for wireless devices in a said geographic region.
  - o Demographic criteria (track wireless devices of users of a said demographic profile
  - o Other customizable criteria
- The ability to simply locate a wireless device **104** and return its location ® The ability to view any saved case files in the user home directory. This includes any manually developed case files as well as case files automatically generated by the user's profile settings—per prior request of the user. The viewing of these said case files would be generated by the preferred embodiments display software **2832** and could have limitations placed n it by access rights. These access rights could limit what layers are displayed on the output. Levels such as network information, cellular tower location, etc could be removed.
- Ability to negotiate file maintenance on a user directory from the remote connection is another option that could have restrictions based on access levels. Maintenance commands could include:

- Delete file
  - Rename file
  - Copy file
  - Etc.
- The ability to remotely submit case files manually for auto-correction (user would require high access).

**[0378]** A specific concern that users would need to be aware of is the ability of their records to be accessed by this system. Wireless devices **104** should be able to submit preference flags that will control access to the tracking and access of their accounts by the said embodiment.

The levels that could be defined for this type of preference are:

1. Open access—any party may access all information about user
2. Limited access (Default option)—information such as the users name, and other private information is masked. Demographic information and the ability to anonymously track the mobile (ex: tracking by demographic information).
3. Polling access—No information is listed under the account, however tracking can still occur but only by geographic region. Results of the track would not include any information other than a generic identifier for the phone
4. No access—under this mode the user may not be tracked, but certain features such as the ability for the user to track him/her self will be disabled.

**[0379]** Ramifications and uses stemming from these access levels are beneficial to the wireless service providers. The wireless service provider can choose to only allow certain levels to be used by a wireless customer. To this regard, under most circumstances they could make it mandatory for most wireless devices to be tracked.

**[0380]** This information is a very valuable commodity. Many applications stemming from this exist beyond the ability for third party applications to simply access, view case files, and setup tracking options.

**[0381]** Two specific claimed additional uses and processes would be:

- Allowing marketing companies access to tracking based on their target audience (demographic/geographic location/etc)
- Traffic Analysis and route planning software

**[0382]** The first process would allow marketing or interested organization/persons to use software to access information about users based on customizable criteria. These criteria could be used to:

- Send wireless messages to the wireless device **104** when it enters a definable geographic region.
- Research consumer habits based on the consumer's profile/demographic information.
- Allow unsolicited interaction with a customer based on a profile set-up by a marketing company with the said process. (for example, and out of town user receives a solicitation for a discounted hotel rate as they enter town).
- Allow a user to request solicitations for specified products or services based on the users geographic location. (For example, the user is at Broadway and V<sup>t</sup> Ave. and wants to know which restaurants in the area have a lunch special.
- Receive a "wireless coupon" for wireless device users **102** on user selected goods and services, based on the users geographic location.
  - o This "wireless coupon" would be realized by transiting the user a coupon code, number or word, etc.,
  - o By putting the user on a "wireless coupon" list comprising the user names and/ or wireless device phone numbers **3724**. This "wireless coupon" list is distributed to the service provider's business.
- Direct the user of the wireless device **104** to the closest service such as a hospital, gas station or restaurant for example.

**[0383]** Of concern to users would be the abuse of this technology. They would be able to block any such attempts by limiting their access rights in their profile, or by wireless providers reaching agreements with its consumers.

**[0384]** The second process is the ability for a directional assistance network (DAN) application

to be developed that could analyze traffic patterns and determine alternate travel patterns that may offer a less congested path for a consumer while driving.

**[0385]** This DAN application would function by first querying the wireless network **100**, ULD **900**, ULDC **908**, or other systems to track all wireless devices **104** in a traffic grid (the geographic criteria would include roadways but not accessible--drivable land). It would then determine which devices are considered to be part of the traffic on a particular roadway.

**[0386]** Because the wireless devices **104** are being tracked by a case file, they can be monitored for movement. If a device is in motion along a roadway grid for more than an allocated (a tunable) time, then it is considered traffic. When this has been calculated, all wireless devices **104** that are not selected are considered to be non-traffic devices.

**[0387]** The system would now look at all moving devices and calculate four attributes:

- Average speed of all wireless devices on a given section of a roadway
- Density of wireless devices on the roadway
- Peak/Min speed of all devices on a road way
- Other programmable criteria

**[0388]** The system would access internal databases to obtain posted traffic speeds on the various road segments. If the average speed is below the posted limit by a programmable amount, then it is deemed congested. If the traffic density is also too dense for the roadway (indicating bumper to bumper) then the traffic density is defined as heavily congested.

**[0389]** Based on these criteria a traffic flow analysis can be done on the entire wireless network **100**. Using the results a program can display to a user where traffic is bad/good in a visual display.

**[0390]** Users can enter into this software a starting location and a destination location. Commonly used software packages are capable of finding simple routes. The standard method would first be used. If the resulting route had a congested element on it, a change would need to

be made for the user.

[0391] The DAN application can then find the fastest route based on roadway congestion. It would tell the route finding software to recalculate a route but NOT use the congested area. The resulting route would be analyzed for congestion again and resubmitted, as before, if necessary.

[0392] The resulting information could easily be sent to the user via the wireless web as a message to their wireless device **104**. The additional programming need would be to interface with an e-mobility application **144** that controls wireless messaging over the wireless web (for example). The route would then be sent directly to the mobile device.

[0393] The user could also select for the route to be continually checked and updates sent to the wireless device **104** until the feature is disabled (by the user reaching the destination) or the feature is timed out by the user entering a time limit. The system knows the identification of the wireless device **104** of the user **102** and then could access the primary embodiment to access the mobile location and travel direction and speed. It could then recalculate the routing information if the user of the wireless device **104** were to get off the primary route. Updates could then be sent to the phone alerting of the change.

#### **Second Alternative Embodiment; Customized Case File Generation**

[0394] The second alternative embodiment comprised within the machine and process of the primary embodiments is a powerful feature for a consumer point of view, which allows the user to have external access to the primary analytical software **2814**. This access, as described in more detail later, can take place from the Internet **3202**, corporate LAN **2912** and from a local computer at the switch (MTX or other) **130**. This access to the primary analytic software **2814** is through a secure connection, and allows the user access to stored case files, the ability to generate customized case files and for use of the primary access software.

[0395] A specific feature of the second alternative embodiment is its ability to allow subprograms the ability to create customized case files. These customized case files contain monitoring data on the wireless network **100** that allow a plurality of data analysis to be made on

the network. This analysis takes place by the fault diagnosis and correction software **2806**. Additional analysis can be done by outside, third party, software. For this reason, special provisions in the preferred embodiments have been made to allow customizable case files to be generated. These custom case files better meet the needs and demands from consumers.

**[0396]** While in normal operation, case files are generated by subprograms as part of their activities. For example, when the user selects the system to monitor for faults and correct them (auto fault correction mode) the system generates case files and then submits them to the fault diagnosis and correction software **2806**. In this instance the generation of the case file is said to be autonomous.

**[0397]** Contrary to this method, case files can also be generated monitoring for specific activities other than faults.

**[0398]** A second mode of generating case files is when the user chooses to have the system create customized case files for specific criteria and simply save the results to a local storage medium. This local medium is defined as part of the storage system that the primary analytic software **2814** is running on. The medium is allocated for storage and divided into user directories that can have information stored into by specific users. A user has the option of looking for wireless network **100** variables other than just *errors*. The system is capable of recording data on the network based on several other criteria such as:

- Single or plurality of said wireless devices based on phone #, ESN, etc.
- Specific sectors on BTS's.
- Plurality of sectors on one or more BTS.
- Time of day
- Geographic criteria (track—create case files—for wireless devices in a said geographic region)
- Demographic criteria (track wireless devices of users of a said demographic profile)
- Other user defined criteria

**[0399]** The first of the customizable criterion is being able to locate devices by a unique

identifier that corresponds to the wireless device **104**. A user may submit a single, or plurality, of identifiers for wireless devices **104** to the preferred embodiment. The monitoring software **2826** will then begin to monitor the network for activity by these devices. Activity can be defined as active calls, active data transfers, or any other form of activity from the wireless device **104**, which would allow tracking on its location to occur. The monitoring software **2802** uses the BSC access control software **2804** to acquire data on these devices and stores it to a local case file for the user's later review.

**[0400]** The next two tracking methods (other than for errors on the network) is when the user specifies specific or a plurality of sectors to track. The primary analytic software **2814** will again use the monitoring software **2802** subprogram to monitor (using the BSC access control software **2904**) the sectors that were specified. All data recorded on these sectors will be stored to a case file **2820** that allows the user to retrieve information and perform data analysis by a third party program at a later time.

**[0401]** The next criteria can be used in conjunction with the above and below criterion for creating case files. The time parameter equals the amount of time for which monitoring should occur on any specified prerequisite criteria. If a user asked for a specific sector to be tracked, the user could then specify for how long (if he didn't then the default time limit—as defined in the software setup—would be used).

**[0402]** Two specialized formats that allow very precise consumer oriented potential are case files **2820** being generated based on geographic and demographic criteria. The first, geographic criteria, is specified by a user in 3 ways: latitude / longitude coordinates and boundaries; geographic criteria that can be chosen from the primary analytic software's **2814** geographic information database **2810**; or from predefined segments. The primary analytic software **2814** responds by translating these inputs into actual sectors that cover these areas. The monitoring software **2802** as well as the device location software **2808** then read in data on active devices in these areas.

**[0403]** A further filter is then applied that removes devices not in the specified geographic region

by comparing their locations with the locations acquired from the device location software **2808**. The result is only devices in the desired region will be recorded to the case file. It also reduces computation power by only monitoring sectors that cover the geographic region chosen by the user. All data recorded on the geographic region will be stored to a case file that allows the user to retrieve information and perform data analysis by a third party program at a later time.

**[0404]** The demographic criterion selection is different, however, in that it can use many of the above criteria to refine its monitoring pattern. Alone, the demographic criterion allows a user to specify demographic information on the user of wireless device **104** on the network to track. This occurs by the user entering the demographic information and the primary analytic software **2814** looking up corresponding users in its local user database. This local user database is derived from a customer profile kept on record by the telecommunication company. Only relevant demographic information can be stored here. Sensitive financial information is not copied here to prevent fraudulent misuse or abuse. The matches are then sent to the monitoring software **2802** to be tracked and recorded to a case file **2820**. Refinements can be used by combining this geographic tracking to limit the area of geographic interest. Time, sector, and other combinations can also be used.

**[0405]** The customizable ability for creating case files **2820** is a component of the preferred embodiment that would allow internal and external programs to generate analysis's that could be beneficial to consumer needs. These needs could be to track a list of employee wireless devices **104** to prevent misuse. Another example is tracking people for targeted marketing strategies.

**[0406]** An important use of case file generation is for non-visible file operations. In these operations, case files are generated for internal programs and used as intermediate steps. When the case file is no longer needed, it is deleted. Its classification would be as a temporary file.

Subprograms that use these temporary case files are:

- Monitoring software **2802**
- Display software **2832**
- Fault diagnostic and correction software **2806**



[0407] The monitoring software **2802** continually creates temporary case files **2820** for internal use. The reason this subprogram uses the temporary case files is so it can capture events that contain errors and send them to the fault diagnostic and correction software **2806**. This software, listed above, then parses the case file and discovers corrections that can be made to the network. Once the corrections are made, the case file can be deleted. This type of internal operation is transparent to the end user, but critical to the normal operation of the primary preferred embodiment.

[0408] The display software **2832** also uses temporary case files when it is required to display certain information to the screen. It parses larger case files into smaller case files so specific information can be analyzed, displayed, and outputted back to the system for further diagnostics. The temporary case files are again transparent to any user's perception.

[0409] Specific examples of a case file being used by the display software **2832** is if a user looks at a larger case file **2820** and then decides to only display certain information (time frame/geographic region/etc). The new display creates a new smaller case file. If the user finds a problem, he can submit the smaller case file for manual correction by the fault diagnostic and correction software **2806**. When this process is done, the temporary case file is again deleted leaving the only original file.

[0410] Circumstances under which temporary case files are not deleted are when a system administrator sets the system to retain these files for debugging or for validation reasons. Modifications to the network by the fault diagnostic and correction software **2806** may need to be checked by engineers after the system makes changes. In this case, retention of the temporary case files is critical.

[0411] Manual deletion, or time marked deletion (delete temp files older than a certain age) is also possible by setting customizable configuration options.

[0412] These listed uses of case files are in no way limiting to the scope of this claimed patent. Derivations and extensions of these ideas are completely within the scope of this patent, and in

no way exceed the spirit in which the herein claimed embodiment is expressed.

**Pro-Active Tuning of a Wireless Device Network**

[0413] Where the primary embodiment of the said patent refers to analyzing the wireless network 100 for errors and then the resulting said processes, there exists the ability for the Network Tuning System (NTS) 2800 to take a pro-active role in network tuning. To allow this possibility to occur, the network must be able to support additional overhead processing. The pro-active tuning requires that the physical hardware used to run the MTX 130 will have enough processing clock cycles and available RAM and storage stage to accommodate this addition. As processing ability varies by MTX 130 design and original provisioning of resources, it is simply stated that the resources will have to be added if they cannot be repositioned from the current architecture.

[0414] The NTS 2800 primary role is to monitor a plurality of sectors or clusters (group of geographically close sectors) for load bearing factors. As a wireless network increases its user load, or due to many other factors, optimum performance is often not obtained. The increased user load can often result in loss of coverage for wireless subscribers. Using the ULD 900 to locate wireless devices and then analyzing network parameters; the pro-active approach allows the NTS 2800 to compensate for various factors that influence network performance.

[0415] Network engineers currently using current industry methods can only design one configuration, which runs until a problem is encountered. At that point, the NTS 2800 could make changes or the network engineer could make modifications based on the network tuning systems reported data and/or recommendations.

**NETWORK FACTORS**

[0416] Factors that can cause the network to perform poorly can occur for varying reasons, and at varying times. The results are the same however, that the perceived Quality of Service, or QoS, is reduced for the user. The primary factors are:

- Thermal interference
- Active Wireless Unit Density

- Terrain Interference
- Network Equipment Performance

#### Thermal Interference

**[0417]** Thermal interference causes Radio Frequency (RF) interference in the RF bands used by wireless subscribers of wireless networks. The core result is that the range a wireless device **104** (cellular phone for example) on a radio tower and BTS network **108** may transmit is reduced significantly. The reduction occurs because the receiver cannot recover the signal in the presence of the thermal noise.

**[0418]** The significance of the noise is that it causes the effective range of a radio tower and BTS network **108** coverage to be reduced. Based on the level of solar activity by the sun this can vary during the daylight hours. The amount of direct daylight is closely proportional to the level of thermal interference causing the strongest periods to be at mid-day and the weakest at sunrise and sunset.

**[0419]** The direct daylight causes the effective area of wireless coverage to vary as the time of day does. Secondly, at nighttime when thermal interference is less; signals can be received/transmitted at much greater lengths. At nighttime the wireless coverage becomes larger than during daylight hours. The primary goal by the pro-active ability of the NTS **2800** is to reduce or eliminate coverage loss due to shrinking radio tower and BTS network **108** coverage area. A secondary goal is to reduce the cross-interference of radio tower and BTS networks **108** when thermal noise is less.

#### Active Wireless Unit Density

**[0420]** Another factor in network coverage is active wireless unit density. Active wireless unit density primarily concerns CDMA/CDMA2000 and other spread spectrum technologies, but has minor implications in technologies such as TDMA, GSM, and other frequency division protocols. The reason that the factor is more affecting to spread spectrum protocols is that due to the fact that users share the same bandwidth, RF activity by individual users are seen as interference to others. The wireless density causes the noise floor to rise and results in a similar

situation as in the thermal noise case.

**[0421]** Technologies such as frequency division typically use guard bands to prevent intra-cluster interference from happening to users in close geographic proximity. There can still be a problem though when frequency reuse levels allow users in relatively close geographic proximity to interfere with each other RF signals.

**[0422]** The typical case would be to consider a sector of a CDMA network. (Note, that this is a real situation using hypothetical numbers that closely approximate actual performance) With only one user, a radio tower and BTS network **108** can send and receive signals to a wireless device **104** at a range of 10km. When a second user in close proximity to the first user and in the coverage of the radio tower and BTS network **108** becomes active, the second user begins to interfere with the wireless device's ability to recover signals from the radio tower and BTS network **108**. The  $E_c/I_0$  reduces from the wireless devices perspective.

**[0423]** As more wireless devices become active, the Echo for each device reduces until the receiver in the wireless device reaches its detection threshold. At this point the wireless device can no longer receive a signal from the tower. The wireless device must move geographically closer to the radio tower and BTS network **108** to receive the signal. The trend tends to decrease coverage for all wireless devices on the sector.

**[0424]** Typical network planning allows for sector coverage overlap and prevents coverage gaps under ideal conditions. When highly dense areas of wireless phones are active, however, coverage may reduce to the point that the typical overlap is no longer present. The high density results in coverage gaps, and loss of wireless device service in the affected areas.

#### Terrain Interference

**[0425]** Terrain Interference is a factor that can be caused by either manmade or natural terrain objects. Man made objects can include:

- New Buildings
- Power Lines

- Artificial Manipulation of natural terrain (cement)
- Other man made objects

Natural terrain interference can be caused by the following factors:

- Foliage Density
- New Foliage
- Leaf Attenuation (density of leafs on Foliage) - Seasonal
- Bodies of Water (water level, location, etc)
- Rain
- Snow

**[0426]** Both natural and manmade factors tend to simply impede RE propagation and cause signal loss. The factors result in radio tower and BTS network **108** coverage that can vary in size. The affect of this is much more gradual than that of active wireless unit density with respect to time.

#### Network Equipment Performance

**[0427]** Network equipment performance inaccuracies are often the case for problems to go unnoticed by a network engineer. The system may be set to have a radio tower and BTS network **108** transmit at a particular power level, but in fact will not. The network equipment performance inaccuracies cause the actual field performance not to follow computer models.

**[0428]** The performance can be seen by evaluation of the sector as it communicates to users. Using the location of users from the ULD **900** the system can determine if the appropriate sectors are communicating with the device. If the incorrect sectors are communicating the transmit level and/or orientation should be changed on the radio tower and BTS network 108 to correct for the field inaccuracies in the equipment.

#### NETWORK COMPENSATION TECHNIQUES

**[0429]** To compensate for performance factors, the system dynamically adjusts the configuration

of the network. The transmit power, intensity, or other transmit measure must be able to be adjusted from the MTX **130**, to make the required changes. The system then can vary the performance dynamically, thus altering RF coverage properties of the network to compensate for the less than optimal network performance.

**[0430]** An additional adjustable factor that is not required but is useful when correcting network hardware performance issues is a variable orientation control for radio tower and BTS network **108** sectors. The variable orientation control would however require additional hardware to be installed to allow remote orientation control of radio tower and BTS network **108**.

#### Thermal Noise

**[0431]** Thermal noise in most cases affects all sectors of a wireless device network relatively equally. The exception is when antennas and hardware on the sectors are exposed to varying amounts of sunlight due to mounting design or location (in a shadow, etc).

**[0432]** The coverage area must be broken into sectors. Computer simulations establish the coverage zone for each sector using ideal factors. **FIG. 48** describes the process for each sector. Each sector undertakes the following process. To adjust for thermal noise interference, the system must first establish the location of all active wireless devices in the predicted coverage zone for a sector **4800**. When the NTS **2800** obtains the location for each device from the ULDIULDC **900/908** or other method, the NTS **2800** records all send and receive powers all devices communicating with the sector via the BSC **300, BOX 4805**.

**[0433]** The measurements are used as follows. The wireless device will transmit at a particular level and report its transmittal strength and/or  $E_c/I_o$  **4810**. The radio tower and BTS network **108** receives the signal from the devices and receives and calculates the normalized  $E_c/I_o$  for the entire sector **4815**.

**[0434]** The network engineer establishes a typical free space loss per unit distance and establishes a minimal  $E_c/I_o$  value for the entire sector. The minimum value can be an included item in the configuration file so the free space loss per unit distance is available to the software.

To establish a minimum value for loss, nighttime measurements would be ideal. The NTS **2800** compares the normalized sector base loss with the minimum loss value. The resulting number indicates the amount of noise affecting the signal **4820**. To insure that the noise is mainly due to thermal conditions, the system can also mathematically remove the added noise by other devices by subtracting the power levels at the distance from the secondary device to the primary devices. The system then increases  $E_c/I_o$  levels to a ratio that compensates for the reduction due to thermal noise. In other words, calculate the amount of reduction in  $E_c/I_o$  due to thermal noise, and then increase the transmit power of the sector until it has increased the  $E_c/I_o$  values to target levels. The increase should be such that the  $E_c$  (energy per chip) increases the ratio back to the base level.

**[0435]** If the recorded  $E_c/I_o$  value of the system is above the normal level by greater than 10dB when the above calculations are done **4825**, the system should reset the transmit power level to its default value and then resample the sector to attempt to get the  $E_c/I_o$  to be at a level that compensates for thermal noise **4830**. If the  $E_c/I_o$  value is less than 10dB above the minimum value **4825**, the NTS **2800** repeats the process for the next sector **4850**. If the  $E_c/I_o$  level is less than the minimum value to maintain coverage, the system should increase the transmit power by some small unit **4835**. If the  $E_c/I_o$  level is 8dB above the minimum level **4840**, the NTS sends an error message to the network engineer **4845**. The NTS then repeats the process for the next sector **4850**. If the  $E_c/I_o$  level is 8dB below the minimum level **4840**, the NTS repeats the process for the same sector **4800**.

#### Active Wireless Unit Density

**[0436] FIG. 49** displays the process to tune a wireless network using the active wireless unit density. To tune the wireless network by active wireless unit density, the NTS **2800** breaks up the coverage area into grids. An example of a grid layout is presented in **FIG. 43**. The number of zones will be determined by the size of the network and the size of each zone. Each zone should be in the range of 0.05-0.25 square-km in size. The zones are analyzed one at a time; say zone 'n' of 'm' total zones.

**[0437]** To compensate for active wireless unit density, the network must first determine the

location of all the mobile units in a particular area **4905**. To get the location of all the wireless devices, the system can submit the coordinates of the zone to the device location software **2808** of the NTS **2800** that queues the ULD **900** for the location of the devices in the sector. It may also retrieve location results via GPS information or direct query of the BSC/MTX **118-A/130**.

**[0438]** When the location has been determined for the wireless devices, the system then determines other sectors currently communicating with the wireless devices. Because QoS is the primary goal and wireless density is a very rapidly changing factor, the Packet loss, Bit Error Rate (BER), or Frame Error Rate (FER) are good standards for measuring the QoS for users. A general practice is that above 2% on any of these parameters is unacceptable for users. A network engineer could however choose the value of this percentage at their discretion for any network configuration.

**[0439]** The NTS **2800** checks if the average density of wireless devices is less than 10 units per  $0.1 \text{ km}^2$  **4910**. If the average density is less than 10 units per  $0.1 \text{ km}^2$ , the NTS **2800** repeats the active wireless unit density tuning process for the next zone **4915**. If the average density is greater than 10 units per  $0.1 \text{ km}^2$ , the BER/FER/Packet Loss value is calculated for each wireless device in the zone **4920**.

**[0440]** The NTS **2800** determines if of the users are experiencing BER, FER, etc of over the threshold limit **4925**. Commonly published studies have shown that if 50% of users with a wireless transmit density of 10 wireless units per  $0.1 \text{ sq km}$  are experiencing error rates greater than 2-20% than they are with a 75-90% likelihood interfering with each other and reducing QoS and coverage. **FIG. 44** shows a typical layout in a wireless network with 3 sector BTS's. Zones B and D have greater than 50% of the active units transmitting with greater than 2-20% BER/FER. QoS is the best measure of network perceived usability and these factors (BER, etc) are used as a gauge by this embodiment to prevent coverage gaps.

**[0441]** Next, the NTS **2800** determines which sector has the largest percentage of users in the zone **4930** and increases the transmit power of the BTS **108** by one unit **4935**. A typical power increase increment would be 1-10dBmW for the transmit strength. The system then checks the



geographically adjacent sectors and makes sure that the unique users on those sectors are not affected by the change (no increase in BER and other determining factors) **4940**. If adjacent sectors are interfered with, the NTS **2800** sends an error message to the network engineer **4950** and the NTS **2800** processes the next zone **4915**. If adjacent sectors are not interfered with, the NTS **2800** checks if the maximum transmit power is reached **4945**.

**[0442]** The maximum level prevents 'overshoot', which is when a sector will project its RF inadvertently into distant sectors coverage. A typical limit could be in the range of 5dBmW to 100dBmW. If the transmit power has not reached the maximum level **4945**, the NTS **2800** repeats the process starting with recording the BER/FER/Packet Loss **4920**. The system will then continue to increase transmit power until the percentage of users failing the 2-20% criteria has either been reduced to below the designated level 50% in spot areas (or another network-engineer prescribed level) or the increase causes an increase in the BER of adjoining sectors polled. If the maximum level is reached, the system sends a report to the network engineer **4950**. The NTS **2800** then analyzes the next zone **4915**.

**[0443]** The technique should be done on every zone in the network. The frequency of the polling and resulting adjustments should be fast, so as stated, adequate processing ability should exist.

#### Terrain Interference

**[0444]** Terrain interference has in some cases limited recoverability in network performance by the pro-active system. In most cases the obstruction cannot be overcome by parameter modifications. To begin the system should query the ULD **900** for the location all wireless devices in the '*theoretical*' zone of coverage for a sector **5005**. This '*theoretical*' zone consists of a predefined geographic area that network engineers expect full coverage from for any given sector on a radio tower and BTS network **108**. Such geographic zones are usually determined during initial network provisioning and are updated when physical changes in RF equipment are made.

**[0445]** A list of all the sectors that all wireless devices in the theoretical zone are communicating with are listed. Devices that are communicating with the sector being diagnosed are kept in a list

(or database entry, file, etc). A list of these sectors, for naming purposes it is called list one, is made for diagnosis. The devices in list one consist of all devices that are both in the theoretical zone and communicating with the sector being diagnosed **5010**. A second list, for naming purposes list two, should be created that contains all devices in the theoretical zone that are not talking to the sector being diagnosed **5015**. Basic interpretation of list two will show all the devices that cannot communicate with the sector being diagnosed. With the exception of software errors, the primary reason is lack of RF coverage from the sector. Software errors can be ruled out by the network tuning system or by a qualified RF engineer using commonly known techniques in the field.

**[0446]** The performance evaluation should be done in zones **5020**. The zones can be defined by percentages of distance from the radio tower and BTS network **108** to the theoretical ending of coverage for the sector **FIG. 45**. Another defining range could be in units of distance, for example meter, miles, feet, etc. There can be an arbitrary number of zones in the system. Further expansion of this method that would only need additional software programming, and does not take away from the novelty of this design, would be to add additional zones in a radial pattern from the radio tower and BTS network **108** in **FIG. 46**. A radial pattern allows multiple zones at the same distance from the radio tower and BTS network **108**. Examples of zones in a 4-zone non-radial divided system are:

- Zone 1 -               0%-25% distance from Sector
- Zone 2 -               25%-50% distance from Sector
- Zone 3 -               50%-75% distance from Sector
- Zone 4—               75%-100% distance from Sector

**[0447]** The zones should be scanned starting from 1 to 4. For a radial divided system, the sub zones should be examined from one radial side to the other, in a sweeping direction that repeats in the same direction for each zone. The scanning should examine list one. List two does not need to be examined because devices are not talking to the sector and would waste both time and resources.

**[0448]** For each zone a calculation of the percentage of devices in list one versus the over all

devices in list one and two for each sector should be made **5025**. If less than 50-80% of the devices in a zone (or sub-grid) are communicating with the radio tower and BTS network **108** sector then an obstruction may exist **5030**. Each sub-grid is flagged either bad or good depending on the communications of the devices in the zone **5035, 5040**. In most cases, the problem areas will result at the extreme edges of the theoretical zone. A second calculation should then be made to calculate the overall coverage of this sector **5045**. The best method is to first disregard all zones on the edges (border zones) of the theoretical coverage **FIG. 47**. The disregard of border zones is most appropriate in radial divided zoning displayed in **FIG. 46**.

**[0449]** With the zones disregarded, the percentage of zones that failed the first criteria (less than 50-80% of the devices in a zone (or sub-zone) are communicating with the radio tower and BTS network **108** sector) should be calculated **5045**. If over 1-20% failed than the system then can attempt to increase transmit power to compensate for this problem **5050**. The power is increased one unit level at a time (as listed in the configuration file). The NTS **2800** checks the power against adjacent sectors as it was with the wireless density factor resolution process as described in this embodiment **5055**. If the wireless density causes interference with an adjacent sector, the NTS **2800** reduces the level by one unit **5060**, sends an error message to the network engineer **5075** and then moves to analyze the next sector **5080**. If there is not interference with adjacent sectors **5055** and the maximum power is not reached **5065**, the NTS **2800** reanalyzes the zones **5070**. The power should be increased until less than 20% of zones in the fail the second calculation (over 1-20% failed) or until a threshold limit is reached on transmit power **5065**. If a limit is reached an error message is sent to the network engineer **5075**.

**[0450]** The technique should be done on every sector in the network. The frequency of the polling and resulting adjustments should be fast, so as stated, adequate processing ability should exist

#### Network Equipment Performance

**[0451]** The network equipment performance of a network can be evaluated by comparing simulated results to actual numbers. **FIG. 51** displays the process to analyze a wireless network using network equipment performance. The NTS **2800** queries the location of all devices on the

theoretical coverage of a sector (say sector "n" of "rn" total sectors in the network) from a ULD **900** and then the received powers (relative to wireless device) are recorded **5105**.

**[0452]** The figures are compared against theoretical numbers for the antenna arrays and their power relative to the locations for wireless units communicating to the hardware. If the measured power levels (receive level) are to off by +/- 20% (compared to theoretical predicted values for the current transmit power) for 80% of the devices then the network equipment is most often the cause **5110**. If the receive level is too high **5115**, the NTS **2800** decreases the transmit power by one unit **5125**. The NTS **2800** then checks if the minimum power level has been reached **5140**. If the minimum level has not been reached, the NTS **2800** checks for interference with adjacent sectors **5145**. If there is no interference, the NTS **2800** repeats the process again for the same sector **5132**. If the minimum power level is reached **5140**, or there is interference with adjacent sectors **5145**, the NTS **2800** sends an error message to the network engineer **5155**, and repeats the process for the next sector **5160**.

**[0453]** If the receive level is too low, the NTS **2800** increases the transmit power by one unit **5120**. The NTS **2800** then checks if the maximum power level has been reached **5135**. If the maximum level has not been reached, the NTS **2800** checks for interference with adjacent sectors **5150**. If there is no interference, the NTS **2800** repeats the process again for the same sector **5132**. If the maximum power level is reached **5135**, or there is interference with adjacent sectors **5150**, the NTS **2800** decreases the transmit power by one unit **5130**, sends an error message to the network engineer **5155**, and repeats the process for the next sector **5160**.

#### IMPLEMENTATION WITH NETWORK TUNING SYSTEM

**[0454]** Implementation using the Network Tuning System requires individual components to perform special functions to accommodate the added functionality of the pro-active monitoring features. The additional features add to the ability of the tuning software allowing it to both correct faults in the system reactively but also proactively monitor and optimize the network to reduce the faults from occurring in the first place.

**[0455]** As stated, the pro-active software **4200** can access the components of the network tuning

system **2800**. The primary analytic software **2814** on the NTS **2800** will run the pro-active software **4200** as an additional subroutine **FIG. 42** and integrate pro-active software **4200** with its native components. The proactive software **4200** can integrate into the NTS **2800** native software structure. The below components of the NTS **2800** are described in regards to their interaction with the pro-active software **4200** and any modifications necessary to allow the NTS **2800** and pro-active software **4200** to integrate seamlessly. The NTS **2800** reference numbers refer to the NTS **FIG. 28**.

#### Monitoring Software (2802)

**[0456]** The monitoring software **2802** in the NTS **2800** is responsible for monitoring the network for error codes generated that indicate irregular network problems and or other indications. The monitoring software **2802** intercepts and decodes error codes produced by the BSC **118-A** and interprets their effects on the wireless device. If the error is service affecting then the fault is sent to the primary analytic software **2814**.

**[0457]** To modify the monitoring software **2802** to allow integration of the proactive system, the monitoring software **2802** should monitor for messaging other than just 'error-codes'. The system needs to monitor for network messaging on individual sectors and clusters of sectors. The primary analytic software **2814** sends a request to the monitoring software **2802** for the network parameters of a single or plurality of sectors. The typical parameters gathered by the monitoring software **2802** and returned to the primary analytic software **2814** for these 'new' types of queries are:

- Echo Forward Link Statistics for active connections
- Ec/Io Reverse Link Statistics for active connections
- Receive Power Forward Link Statistics for active connections
- Receive Power Reverse Link Statistics for active connections
- Reverse Link Transmit Power Statistics for active connections
- Forward Link BER/FER Statistics for active connections
- Reverse Link BER/FER Statistics for active connections
- Reference List of Mobile Identifiers for all Mobile Devices on Sector(s)

- Other User Defined Variables

#### *BSC Access Control Software (2804)*

[0458] The base station controller (BSC) access control software **2804** is responsible for interfacing the components and processes of the current invention with the BSC **118-A** of a wireless network. The BSC **118-A** contains all the call information as well as all the information on network faults. It should be noted that some wireless network designs have the network fault information stored elsewhere, and that the BSC access control software **2804** could be used to access that information at any other location also. The BSC access control software **2804** interacts directly with the BSC **118-A** and the primary analytic software **2814** as well as the monitoring software **2804**.

[0459] The monitoring software **2804** specifically uses the BSC access control software **2804** to retrieve network statistics such as Echo and Receive Powers from the BTS/Sectors(s) for pro-active queries of the pro-active software **4200**.

#### *Fault Diagnosis and Correction Software (2806)*

[0460] The fault diagnosis and correction software **2806** is typically responsible for obtaining case files from the primary analytic software **2814** and generating a solutions and implementing changes to the network to resolve the problem. The modifications necessary to accommodate the pro-active software **4200** are a new set of protocols that are defined for pro-active network monitoring. The protocols are specifically designed to address the four issues: Thermal Interference, Active Wireless Unit Density, Terrain Interference, and Network Equipment Performance. The protocols as described in the 'Network Compensation' section allow the fault diagnosis and correction software **2806** to react to case files that contain the pro-active data and make appropriate changes to the network, as it would do for reactive 'fault' case files.

#### Device Location Software (2808)

[0461] The device location software **2808** is the package that when activated by the primary analytic software **2814** is able to retrieve information from a database such as a ULD **900**, or a ULDC **908**, that holds geographic information (as well as time, date of the acquired geographic

information). Additionally, as an alternative embodiment this device location software **2808** can directly query the BSC **118-A** and calculate the location of a wireless device **104**, as instructed by the primary analytic software **2814**. The device location software **2808** interacts directly with the BSC **118-A**, the primary analytic software **2814**, the User Location Database **900** and/or User Location Database Coordinator **1600**.

**[0462]** To modify the device location software **2808** to allow integration of the proactive software's **4200** new features only limited changes must be made. The first change is that the queries from the primary analytic software **2814** must be given a higher priority than normal queries when they regard pro-active monitoring. When the primary analytic software **2814** queries the monitoring software **2802** for the network statistics of a single or plurality of sectors, the primary analytic software **2814** receives a list of wireless identifiers. The primary analytic software **2814** then immediately queries the device location software **2808** for the location of the said devices returned from the monitoring software **2802**.

**[0463]** To allow for the location to be as synchronized to the data from the sectors, the location should be retrieved quickly. In this case, and messages queued with lower priorities should be bypassed and these queries should be processed first. In practice, the pro-active location queries should only be superceded by manual location submissions (or overrides by an administrator).

#### User Location Database Coordinator (1600)

**[0464]** No modifications to the User Location Database Coordinator (ULDC) **908** or similar software/hardware and necessary because it is simply used as an intermediary to resolve the location of mobile devices.

#### User Location Database (900)

**[0465]** No modifications to the User Location Database (ULD) **900** or similar software/hardware and necessary because it is simply used as a resource to obtain the location of mobile devices.

#### Geographic Information Database (2810)

**[0466]** No modifications to the geographic information database **2810** or similar

software/hardware and necessary because it is simply used as an resource to obtain the mapping information that is not specifically needed for the pro-active software **4200** to operate.

Case Files with Lat/Long Correlations (2820)

**[0467]** Case files are typically created to contain-the appropriate information for reactive diagnostics for the fault diagnosis and correction software **2806**. For the case of a pro-active diagnostic to be performed by the fault diagnosis and correction software **2806**, a modified version of the standard case file must be submitted.

**[0468]** The modifications to the standard case only need to include an additional database field indicating pro-active or reactive case files type. Having this field allows the fault diagnosis and correction software **2806** to determine what diagnostic protocols to use to analyze the case file. In the case of the pro-active field being marked, the system would use the new protocols listed in the 'Network Compensation Techniques' section.

Radio Tower Lat/Long Correlations (2824)

**[0469]** No modifications to the radio tower lat/long correlations 2824 or similar software/database entries and necessary because it is simply used as a resource to obtain the mapping and analytical iQformationl. Its uses are the same in the new configuration that includes the pro-active software 4200.

Internal Memory Storage (2818)

**[0470]** Additional memory should be added to allow the pro-active software **4200** to function with additional overhead and not require hard disk caching of data. The amount may vary by final software implementation and network hardware design. Software engineers using standard provisioning techniques should determine the final amount of additional memory.

Internal Central Processing Unit and Computer (2816)

**[0471]** Additional CPU processing power should be added to allow the pro-active software **4200** to function with additional overhead clock cycles and not encounter CPU maximum utilization at peak operating conditions. The amount of additional processing ability may vary by final



software implementation and network hardware design. Software engineers using standard provisioning techniques should determine the final amount of additional processor ability.

#### User Interface Software (2826)

**[0472]** The modifications to the user interface software **2826** are simply to add additional menu systems to the software to allow integration with the pro-active software **4200**. The following commands should be available for the user and be displayed by the display software for the user.

The order and menu placement is suggested to be as follows:

Main Menu Item: Pro-Active Features

<Pro-Active Features>

- Thermal Interference
  - o Configure Thermal Interference
  - o Activate/Deactivate Thermal Interference
  - o Exit Thermal Interference
- Active Wireless Unit Density
  - o Configure Active Wireless Unit Density
  - o Activate/Deactivate Active Wireless Unit Density
  - o Exit Active Wireless Unit Density
- Terrain Interference
  - o Configure Terrain interference
  - o Activate/Deactivate Terrain Interference
  - o Exit Terrain Interference
- Network Equipment Performance
  - o Configure Network Equipment Performance
  - o Activate/Deactivate Network Equipment Performance
  - o Exit Network Equipment Performance Exit Pro-Active Menu

**[0473]** In the manual verification mode any changes will not occur until a network engineer verifies the change. A list of suggested changes and the case file that is created will be sent to engineers as the changes are created. In auto correction mode all changes will be made immediately. To reduce any system catastrophes network wide changes are limited to certain

tolerances in the diagnostic protocols to eliminate network instability issues.

Correlating Mapping Software (2828)

[0474] No modification to the correlated mapping software **2828** or similar software/hardware is necessary because it is not specifically needed for the proactive software to operate.

Correlating Data For Lat/Long Information (2830)

[0475] No modification to the correlated data for lat/long information **2830** or similar software/database entry(s) is necessary because its uses are the same in the new configuration that includes the pro-active software **4200**.

Display Software (2832)

[0476] The display software **2832** does not need modified because it is used in the same way when the pro-active software is integrated.

Primary Analytic Software (2814)

[0477] The primary analytic software **2814** is the controlling software of the NTS and integrates all the elements into a single software package for a user. From the software, a user may access all features of the system and run either active, passive, or inactive modes. The pro-active system **4200** can integrate in the primary analytic software **2814** in the active and passive modes. However, many features can only be available in the active mode due to the real-time requirements for some pro-active tuning features. Passive mode will always prompt the network engineer before making changes and therefore is unrealistic for most pro-active features.

[0478] All features are available in the active mode while only the terrain and network features are available in the passive mode. The specific reason is listed below for each feature.

[0479] Thermal Interference - The ability for the system to react to thermal interference requires a CASE file to be generated frequently to record network performance factors that indicate thermal interference. A typical interval will be at 10-30 minute intervals. The primary analytic

software **2814** then submits the changes to the fault diagnosis and correction software **2806** where modifications for pro-active diagnostics are implemented. The frequency in manual mode is to frequent for network engineers to manually approve each time. Active mode allows case files to be sent automatically and modifications to be made also.

**[0480]** Active Wireless Unit Density - Active mobile unit density is a rapidly changing factor that changes every second or faster. The processing ability and excess overhead internal trunking affect the time necessary to calculate density. CASE files are generated as fast as possible without affecting other vital processes. The system could not send network engineer approval requests before making changes.

**[0481]** Specific changes to accommodate the inclusion of the pro-active features are very specific. First, all CASE files created that are for pro-active features must have a flag set that indicates that fact. The flag allows fast routing of the diagnostics to be considered by new pro-active decision algorithms. Second, the system must first allocate additional processing power and other resources for pro-active features as the active wireless unit density specifically requires additional processing power that can take away from other processes.

#### USER INTERACTION WITH THE PRO-ACTIVE SYSTEM

**[0482]** The user's primary interaction will be through the display software **2832** and will interact with the additional menu items. As described in the display software section, the user may access these menus to control the new features. Specific interaction and the results are listed below for all the new menu items. Also to be noted, the user may access this system using the existing tuning system's architecture that allows for remote access via intranet, Internet, and other devices.

**[0483]** Main Menu Item: Pro-Active Features **5205**: The additional menu item appears at the main menu, which is presented to a user after logging on to the system and being authenticated.

**[0484]** Thermal Interference **5210**: Selecting this feature enables the system to monitor and adapt to thermal interference.

[0485] Configure Thermal Tuning **5211**: The selection allows the user to edit the thermal tuning configuration file.

[0486] Enable/Disable Thermal Tuning **5212**: The selection toggles enable or disable thermal tuning.

[0487] Exit **5213**: Exits the thermal tuning menu.

[0488] Active Wireless Unit Density **5215**: Selecting this feature enables the system to monitor and adapt to active wireless unit density.

[0489] Configure Active Wireless Unit Density Tuning **5216**: The selection allows the user to edit the active wireless unit density tuning configuration file.

[0490] Enable/Disable Active Wireless Unit Density Tuning **5217**: The selection toggles enable or disable active wireless unit density tuning.

[0491] Exit **5218**: Exits the active wireless unit density tuning menu.

[0492] Terrain Interference **5220**: Selecting this feature enables the system to monitor and adapt to terrain interference.

[0493] Configure Terrain Tuning **5221**: The selection allows the user to edit the terrain tuning configuration file.

[0494] Enable/Disable Terrain Tuning **5222**: The selection toggles enable or disable terrain tuning.

[0495] Exit **5223**: Exits the terrain tuning menu.

[0496] Network Equipment Performance **5225**: Selecting this feature enables the system to

monitor and adapt to network equipment performance.

[0497] Configure Network Equipment Tuning **5226**: The selection allows the user to edit the network equipment tuning configuration file.

[0498] Enable/Disable Network Equipment Tuning **5227**: The selection toggles enable or disable network equipment tuning.

[0499] Exit **5228**: Exits the network equipment tuning menu.

[0500] Exit **5230**: Exits the pro-active tuning menu.

## **LOCATION TRACKING SYSTEM**

### **DETAILED DESCRIPTION OF THE OPERATIONS DRAWINGS**

#### **[0501] FIG. 53**

**FIG. 53** is a flowchart illustrating the process of a user logging into the location tracking system (LTS) **5300**. The LTS **5300** may be provided by a wireless service provider, an internet website provider, an asset tracking service, an employee tracking service, a personal tracking service or other types of service providers. The user accesses the LTS **5300** thru an internet **3202** website, a wireless interface, a wireless service provider, publicly switched telephone network **138**, a fax on demand service, an automated telephone system, a laptop/desktop computer **2910**, a PDA, a wireless device 104, or other types of devices.

[0502] To begin the login process, the LTS **5300** prompts the user to enter a username and password **5302**. The LTS **5300** then waits for the user to respond with a username and password **5304**. If the user responds **5304**, the LTS's **5300** internal CPU and computer **2816** logs the entered username and password **5304** into its internal storage memory **5306**. The LTS **5300** checks the LTS's **5300** membership database for the username and password **5304**. If the LTS **5300** finds the user's record **5312**, the user then enters the desired telephone number, **FIG. 53, BOX 5314. FIG. 54** displays the complete entry process. If the user's records cannot be found **5312**, the LTS **5300** informs the user that there is a problem with the username or password

**5302**, and the user is returned to **FIG. 53, BOX 5302**, as shown in **FIG. 53, BOX 5316**. The LTS **5300** then prompts the user to enter username and password **5302**.

**[0503]** If the user does not enter a username and/or password **5304**, the LTS **5300** prompts the user to become a user of record **5312** by entering personal information and billing information into the LTS **5318**. The LTS **5300** then waits for the user to enter personal and billing information **5320**. If the user does not enter personal and billing information within a specified period of time **5320**, the user is logged off **5322** the LTS **5300**, sent to help menu or forwarded to a service agent or operator **5322**, depending on the configuration of the LTS **5300** settings and the users choice. If the user enters personal and billing information **5320**, the LTS's **5300** internal CPU and computer **2816** logs the personal information and billing information into its internal storage memory **5306**. The LTS **5300** then attempts to verify the user's personal information and billing information **5326** by placing a call through a modem to the LTS's **5300** merchant credit card services account and charges to the users credit card **5326**. If the user's personal and billing information can be verified **5328**, and the users credit card is billed, the LTS **5300** establishes a user record **5312** by transferring the logging the personal and billing information from the internal storage memory **5306** to the LTS's membership database **5308**. The user is then enters the desired telephone number, **FIG. 53, BOX 5332**. **FIG. 54** displays the complete entry process. If the user's personal information and billing information cannot be verified **5328**, the user is notified is a problem with their personal information and billing information and returned to **FIG. 53, BOX 5318**, as shown in **FIG. 53, BOX 5330**.

**[0504]** The user login, personal information and billing information are optional features of this embodiment. The LTS **5300** may be provided at no charge, or offered as a value added feature in conjunction with other services. Whoever, if the user wishes to utilize all the features of the LTS **5300**, a login is required to enable the LTS **5300** to retrieve and access the user's settings and user's entries from the LTS's **5300** memory.

**[0505] FIG. 54**

**FIG. 54** illustrates the initial entry of a phone number that the user wishes to track. Once the user has logged onto the LTS **5300**, the internal computer and CPU **2816** checks the users records

**5312** if the user has a phonebook saved in the membership database **5400**. If the user has phonebook entries saved as part of the user's records, the LTS **5300** gives the user menu choices, **5404**. This process is illustrated in **FIG. 55**.

**[0506]** If the user has not previously saved an entry into the phonebook **5400**, the LTS **5300** then prompts the user to enter the telephone number or identification information of the wireless device **104** the user wishes to locate and/or track **5402**. The LTS **5300** then waits a specified period for the user to enter a telephone number **5406**. If the user enters a telephone number for a wireless device **104** that they wish to track, the LTS **5300** logs the user's entry into the internal storage memory **5306**. The LTS **5300** then queries a user location database(ULD) **900**, user location database coordinator(ULDC) **908**, access users case files **2820**, queries the base station controller (BSC) **206** of a wireless network **100** with the LTS's device location software **2808** for the lat/long coordinates of the wireless device **104** being tracked, Global Positioning System (GPS) Information, or other means of obtaining locations of wireless devices **5406**. The use of ULD **900**, ULDC **908**, and other location means is disclosed (offered only as an example of location means) in a Provisional Patent Application Serial Number 60/327,327; and was files on October 4, 2001. If the wireless device **104** is not located, the user is informed of the problem, and returned to **FIG. 54, BOX 5402**, as illustrated in **FIG. 54, BOX 5416**.

**[0507]** If the wireless device **104** is located **5414**, the LTS **5300** receives the lat/long coordinates and displays the lat/long coordinates to the user in their choice of formats. For example, the location may be overlaid on a display screen **2836** along with a street map overlay **5418**, a map of the overlaid screens may be faxed to a user via a fax on demand service, the location may be converted to a postal address **5422** or cross-street using the LTS's postal address conversion software **5422** and displayed on a screen **2836**, faxed to a user, or read to a user over the phone using the LTS's **5300** automated answering system and voice text read-up software **5426**. Once the wireless device **104** has been located and displayed **5418**, the LTS **5300** prompts the user to enter the specific wireless device **104** into a user phonebook by selecting "phonebook" **5428**. If the user selects "phonebook" **5428** to save the entry to their Phonebook **5430**, the user is forwarded to the phonebook menu section, **FIG. 56, BOX 5600**, as illustrated in **FIG. 54, BOX 5432**. If the user does not select to save the current entry to their phone book **5330**, the user is

forwarded to the phonebook section of the user's choice menu **FIG. 55, BOX 5500**, as illustrated is **FIG. 54, BOX 5434**.

**[0508]** When prompted by the LTS **5406**, if the user does not enter a phone number of the wireless device **104** they wish to locate and/or track, the LTS **5300** prompts the user to enter other identification information such as a persons name, company name, or other identifying information **5438**. If the user does not enter identification information within a specified period of time **5438**, the LTS **5300** logs off the user **5440**. If the user enters identification information **5438**, the LTS **5300** logs the user's entry, and the identification information is then cross referenced against the LTS's Cuss-Cross Phonebook database **2812** or other supplies sources to obtain the phone number for the desired wireless device **5442**. If the LTS **5300** finds the phone number **5410**, the LTS **5300** logs the phone number **5406**, and the location process continues as described as if the user entered the number described above **5408**. If the phone number of the wireless device **104** cannot be located in the Criss-Cross Phonebook database **2812**, the LTS **5300** informs the user the number could not be found and prompts the user to enter a phone number **5412**.

**[0509] FIG. 55**

**FIG. 55** illustrated the processing of the user's choice menu **5502**. The user's choice menu's **5502** physical realization may be in the form of a display screen **2836** navigated by a mouse, keyboard/keypad, interactive display screen, voice recognition or other forms of selection. The user's choice menu **5502** also may be an automated answering system and could be navigated by voice recognition, a keyboard/keypad or other forms of selection.

**[0510]** Initially, the LTS **5300** prompts the user to enter a phone number of a wireless device **104** that the user wants to locate or track by selecting 'locate" **5500**. The LTS **5300** waits a specified period for the user to select 'locate" **5504**. If the user responds by selecting 'locate" **5504**, the LTS **5300** asks the user to enter a phone number by the process described in **FIG. 54, FIG. 55, BOX 5506**.

**[0511]** If the user does not respond within the specified period of time **5504**, the LTS **5300**



prompts the user to select a phonebook entry he wishes to locate **5508**. The LTS **5300** then waits a specified period for the user to select "phonebook" **5530**. If the user responds by selecting "phonebook" **5330**, the user selects the building he wants to display **5510**. **FIG. 56** describes the process.

**[0512]** If the user does not respond within the specified period of time **5530**, the LTS **5300** prompts the user to add, delete or edit a phonebook entry(ies) to a wireless device(s) <sup>104</sup> that the user wants to locate/track by selecting 'Add, Delete or Edit' **5512**. The LTS **5300** then waits a specified period for the user to select "Add, Delete, or Edit" **5514**. If the user responds by selecting "Add, Delete or Edit" **5514**, the LTS **5300** prompts the user to add, delete, or edit phonebook entries **5516**. **FIG. 57** describes the process.

**[0513]** If the user does not respond within the specified period **5514**, the LTS **5300** prompts the user to view selected businesses, government buildings, and/or homes on the display screen by selecting "buildings" **5518**. The LTS **5300** then waits a specified period for the user to select "buildings" **5520**. If the user responds by selecting "buildings" **5520**, the LTS **5300** prompts the user to select buildings to display **5522**. **FIG. 58** describes the process to select buildings for display.

**[0514]** If the user does not respond within the specified period **5520**, the LTS **5300** prompts the user to view a history of call/location/tracking history of phonebook entry(ies) to a wireless device(s) <sup>104</sup> that the user wants to locate/track by selection "view history" **5524**. The LTS **5300** then waits a specified period for the user to select "view history" **5526**. If the user responds by selecting "view history" **5526**, the LTS **5300** forwards the user to the view history process **5528**. **FIG. 67** illustrates the view history process.

**[0515]** If the user does not respond within the specified period of time **5526**, the LTS **5300** prompts the user to print a history of call/location history of phonebook entry(ies) to a wireless device(s) <sup>104</sup> by selecting "print history" **5530**. The LTS **5300** then waits a specified period for the user to select "print history" **5532**. If the user responds by selecting "print history" **5532**, the LTS **5300** forwards the user to the print history process **5534**. **FIG. 68** illustrates the print history

process.

**[0516]** If the user does not respond within the specified period of time **5530**, the LTS **5300** prompts the user to add a history of call/location/tracking history to the wireless service bill by selecting "add to bill" **5536**. The LTS **5300** then waits a specified period for the user to select 'add to bill" **5538**. If the user responds by selecting 'add to bill" **5539**, the LTS **5300** executes the process to add the call/location report to the wireless service bill **5540**. **FIG. 69** illustrates the process to add the call/location report to the wireless service bill. If the user does not respond within the specified period **5538**, the LTS **5300** logs the user off **5542**.

**[0517] FIG. 56**

**FIG. 56**, illustrates the process of entering and selecting phonebook entries. When the user is transferred to the "phonebook" section, the LTS **5300** first queries the user records **5312** to determine if the user is currently locating/tracking the location of a wireless device **5600**. If the LTS **5300** is currently locating/tracking a wireless device **5600**, the LTS **5300** logs the current entry into the phonebook **5602**. The LTS **5300** then displays the user's phonebook including the new entry **5604**. Once the LTS **5300** displays the phonebook **5604**, the LTS **5300** prompts the user to select phonebook entries that they would like to locate/track **5606**. The LTS **5300** then waits a specified period for the user to respond **5608**. If the user selects phonebook entries to be located/tracked **5608**, the LTS **5300** logs the selected phonebook entries and retrieves the location of the wireless devices **104** requested by the user **5610**. The LTS **5300** retrieves the lat/long locations of the wireless devices **104** by querying a ULD **900**, a ULDC **908**, by querying case files **2820** containing lat/long of wireless devices **104**, by querying the wireless network's BSC **206** or by other location means. The LTS **5300** then plots the lat/long of the located wireless devices **104** and overlays the locations onto a street/topographic map **5612**.

**[0518]** If the LTS **5300** is not able to locate a selected entry, the LTS **5300** notifies the user that the entry(ies) could not be located **5614**. The LTS **5300** then prompts the user to select businesses, government buildings and/or private homes to be added to the display screen by selecting "buildings" **5518**. The LTS **5300** then waits a specified period for the user to select "buildings" **5520**. If the user selects "buildings" **5520**, the LTS **5300** prompts the user to select

buildings for display **5522**. **FIG. 58** illustrates the process. If the user does not select "buildings" **5520**, the user is forwarded to the user choice menu **5502**.

**[0519]** If the LTS **5300** is not currently locating/tracking a wireless device 104 when the user logs into the "phonebook" menu **5600**, the LTS **5300** determines if the user has previously established a phonebook containing stored entries, within the user's record **5312**. If the user does have a phonebook within the user's record **5312**, the LTS **5300** displays the user's phonebook **5616**, and the LTS **5300** permits the user to select and locate wireless devices **104** from their phonebook **5606**. If the user does not have a phonebook as part of the user's records **5312**, the user is informed that no phonebook records are contained in the user's record **5618**, and the LTS **5300** forwards the user to the user's choice menu **5502**.

**[0520] FIG. 57**

**FIG. 57** illustrates the "add, delete, and editing phonebook entries menu". The diagram illustrates the process, which allows users to add, delete, and edit phonebook entries. The LTS **5300** prompts the user to add a new entry to the phonebook by selecting "add" **5700**. The LTS **5300** then waits a specified period for the user to respond by selecting "add" **5702**. If the user responds by selecting "add" **5702** a new entry, the LTS **5300** prompts the user to enter a telephone number or identification information **5704**, described in **FIG. 54**.

**[0521]** If the user does not respond **5702**, the LTS **5300** then prompts the user to delete an existing entry in the phonebook by selecting "delete" **5706**. The LTS **5300** then waits a specified period for the user to respond selecting "delete" **5708**. If the user responds by selecting "delete" **5708**, the LTS **5300** allows the user to delete a selected phonebook entry and the LTS **5300** logs the change **5710** to the user's record **5312**. The LTS **5300** then forwards the user to the user's choice menu **5502**.

**[0522]** If the user does not respond within the specified period of time 5708, the LTS **5300** then prompts the user to edit an existing entry in the phonebook by selecting "edit" **5712**. The LTS **5300** then waits a specified period for the user to respond selecting 'edit' **5712**. If the user responds by selecting 'edit' **5714**, the LTS **5300** allows the user to edit a selected phonebook

entry and the LTS 5300 logs the change 5716 to the user's record 5312. The LTS 5300 forwards the user to the user's choice menu 5502. If the user does not respond within the specified period of time 5714, the LTS 5300 forwards the user to the user's choice menu 5502.

**[0523] FIG. 58**

**FIG. 58** illustrates the process of selection "buildings" that will be displayed on the display screen 2836. The LTS 5300 determines the user's current location 5800. The LTS 5300 prompts the user to enter or select a city by city name or zip code if the default city is not desired 5802. The LTS 5300 waits for the user to select a city 5804. If the user selects a different city 5804, the LTS 5300 logs the user's choice and makes it the default city 5806. After the user selects a city, the LTS 5300 checks if the user has entries in the building memory 5808. If the user does not have entries in the building memory 5808, the LTS 5300 sends the user to the building memory choice menu 5810, described in **FIG. 59**. If the user has entries in the building memory 5808, the LTS 5300 asks the user if he wants to select "building memory" 5812. The LTS 5300 waits for user response 5814. If the user does not select "building memory" 5814, the LTS 5300 sends the user to the building memory choice menu 5814 described in **FIG. 59**. If the user selects "building memory" 5814, the LTS 5300 displays the user's building memory and prompts the user to select entries 5816. The LTS 5300 waits for a user response 5818. If the user selects entries, the selected entries are display on the display screen 5820. Then the LTS 5300 sends the user to the building memory choice menu 5810 described in **FIG. 59**. If the user does not select any entries 5818, the LTS 5300 sends the user to the building memory choice menu 5810 described in **FIG. 59**.

**[0524] FIG. 59**

The building memory user's choice menu 5902 allows the user to add, select, and delete entries to their building memory. The LTS 5300 prompts the user to select a business, government office or home by selection "Display Building" 5900. If the user selects "display building" 5902, the LTS 5300 prompts the user to enter the listing they want to display 5904. If the user does not select "display building" 5902, the LTS 5300 prompts the user to add an entry to the building memory by selecting "add" 5906. If the user selects "add" 5908, the LTS 5300 forwards the user to the add building process 5910. **FIG. 60** illustrates the add building process.

[0525] If the user does not select add 5914, the LTS 5300 prompts the user to delete an entry in the building memory by selecting "delete" 5912. If the user selects "delete" 5914, the LTS 5300 logs the user's choice and displays the user's building memory 5916. The LTS 5300 prompts the user to select the entry he wants to delete 5918. If the user selects an entry 5920, the LTS 5300 logs the user's choice and deletes the entry from the building memory 5922. The LTS 5300 then prompts the user to either go to the user's choice menu or log off 5924. If the user selects to go to the user's choice menu 5926, the LTS 5300 returns the user to the user's choice menu 5502. If the user chooses to logoff 5926, the LTS 5300 logs the user off the system 5930.

[0526] If the user does not select an entry to delete 5930, the LTS 5300 then prompts the user to either go to the user's choice menu or log off 5924. If the user selects to go to the user's choice menu 5926, the LTS 5300 returns the user to the user's choice menu 5502. If the user chooses to logoff 5926, the LTS 5300 logs the user off the system 5930.

[0527] If the user does not select the "delete" option 5912, the LTS 5300 then prompts the user to either go to the user's choice menu or log off 5924. If the user selects to go to the user's choice menu 5926, the LTS 5300 returns the user to the user's choice menu 5502. If the user chooses to logoff 5926, the LTS 5300 logs the user off the system 5930.

[0528] **FIG. 60**

**FIG. 60** continues the building memory process and illustrates the process to add an entry to the building memory. The LTS 5300 prompts the user to add a new building by selecting "name", "category", "address", or "phone number" 6000. If the user selects "name" 6002, the LTS 5300 adds the entry by name 6004. **FIG. 63** illustrates the process to add an entry by name. If the user selects "category" 6006, the LTS 5300 adds the entry by category 6008. **FIG. 64** illustrates the process to add an entry by category. If the user selects "address" 6010, the LTS 5300 adds the entry by address 6012. **FIG. 65** illustrates the process to add an entry by address. If the user selects "phone number" 6014, the LTS 5300 adds the entry by phone number 6016. **FIG. 66** illustrates the process to add an entry by phone number. If the user does not select any menu option 6014, the LTS 5300 returns the user to the user's choice menu 5502.

**[0529] FIG. 61**

**FIG. 61** illustrates the process for categorizing the building memory. The LTS 5300 logs the user's choice and prompts the user to enter the desired listing by name, category, address or phone number 6100. If the user enters a listing 6102, the LTS 5300 adds a "listing" 6104. **FIG. 62** illustrates the add "listing" process.

**[0530]** If the user does not enter a "listing" 6102, the LTS 5300 prompts the user to enter the name of the desired entry 6106. If the user enters a name 6108, the LTS 5300 adds the entry by name 6110. **FIG. 63** illustrates the process to add an entry by name. If the user does not enter name 6108, the LTS 5300 prompts the user to enter a category 6112. If the user enters a category 6114, the LTS 5300 adds the entry by category 6116. **FIG. 64** illustrates the process to add an entry by category. If the user does not enter a category 6114, the LTS 5300 prompts the user to enter an address 6118. If the user enters an address 6120, the LTS 5300 adds the entry by address 6122. **FIG. 65** illustrates the process to add an entry by address. If the user does not enter an address 6120, the LTS 5300 prompts the user to enter a phone number 6124. If the user enters a phone number 6126, the LTS 5300 adds the entry by phone number 6128. **FIG. 66** illustrates the process to add an entry by address.

**[0531]** If the user does not enter a phone number 6126, the LTS 5300 returns the user to the user's choice menu 5502.

**[0532] FIG. 62**

**FIG. 62** displays the process to enter a "listing" to the building memory. The LTS 5300 logs the user's entered listing and searches the criss-cross phonebook with the lat/long correlation 2810 or address coordinates for all matching entries 6200. If the listing is not found 1005, the LTS notifies the user the listing is not found 6202 and the user is sent to the user choices menu 5502. If the listing is found 6202, the LTS 5300 displays all the entries that contain the entered "listing" and the LTS 5300 prompts the user to select the desired entry 6206. If the user does not select a listing 6208, the user is sent to the user choices menu 5502. If the user selects an entry 6208, the LTS 5300 displays the selected listing on the display screen 2836 with the following information: name, category of listing, address, and phone number. The LTS 5300 plots and

labels the listing location on a street map with the location of the wireless devices **6210**. The LTS **5300** prompts the user if he wants to save the listing in the building memory **6212**. If the user does not save the listing **6214**, he is sent to the user choices menu **5502**. If the user saves the listing, the LTS **5300** saves the listing in the building memory **6216**, and the LTS **5300** returns the user to the building memory user's choice menu **6218**.

**[0533] FIG. 63**

**FIG. 63** displays the process to enter a "name" to the building memory. The LTS **5300** logs the user's entered name and searches the criss-cross phonebook with the lat/long correlation **2812** or address correlation's for all matching entries **6300**. If the name is not found **6302**, the LTS **5300** notifies the user the listing is not found **6304** and the user is sent to the user choices menu **5502**. If the listing is found **6302**, the LTS **5300** displays all the entries that contain the entered "name" and the LTS **5300** prompts the user to select the desired entry **6306**. If the user does not select a listing **6308**, the user is sent to the user choices menu **5502**. If the user selects an entry **6308**, the LTS **5300** displays the selected listing on the display screen **2836** with the following information: name, category of listing, address, and phone number. The LTS **5300** plots and labels the listing location on a street map with the location of the wireless devices **6310**. The LTS **5300** prompts the user if he wants to save the listing in the building memory **6212**. If the user does not save the listing **6214**, he is sent to the user choices menu **5502**. If the user saves the listing, the LTS **5300** saves the listing in the building memory **6316**, and the LTS **5300** and the LTS **5300** returns the user to the building memory user's choice menu **6218**.

**[0534] FIG. 64**

**FIG. 64** displays the process to enter a "category" to the building memory. The LTS **5300** logs the user's entered listing and searches the criss-cross phonebook with the lat/long correlations **2812** or address coordinates for all matching entries **6400**. If the listing is not found **6402**, the LTS **5300** notifies the user the listing is not found **6404** and the user is sent to the user choices menu **5502**. If the listing is found **6204**, the LTS **5300** displays all the entries that contain the entered "category" and the LTS **5300** prompts the user to select the desired entry **6406**. If the user does not select a listing **6408**, the user is sent to the user choices menu **5502**. If the user selects an entry **6408**, the LTS **5300** displays the selected listing on the display screen **2836** with

the following information: name, category of listing, address, and phone number. The LTS 5300 plots and labels the listing location on a street map with the location of the wireless devices 6410. The LTS 5300 prompts the user if he wants to save the listing in the building memory 6212. If the user does not save the listing 6214, he is sent to the user choices menu 5502. If the user saves the listing, the LTS 5300 saves the listing in the building memory 6216, and the LTS 5300 and the LTS 5300 returns the user to the building memory user's choice menu 6218.

**[0535] FIG. 65**

**FIG. 65** displays the process to enter a "address" to the building memory. The LTS 5300 logs the user's entered listing and searches the criss-cross phonebook with the lat/long correlations 2812 or address coordinates for all matching entries 6500. If the listing is not found 6502, the LTS 5300 notifies the user the listing is not found 6504 and the user is sent to the user choices menu 5502. If the listing is found 6502, the LTS 5300 displays all the entries that contain the entered "address" and the LTS 5300 prompts the user to select the desired entry 6506. If the user does not select a listing 6508, the user is sent to the user choices menu 5502. If the user selects an entry 6508, the LTS 5300 displays the selected listing on the display screen 2836 with the following information: name, category of listing, address, and phone number. The LTS 5300 plots and labels the listing location on a street map with the location of the wireless devices 6510. The LTS 5300 prompts the user if he wants to save the listing in the building memory 6212. If the user does not save the listing 6214, he is sent to the user choices menu 5502. If the user saves the listing, the LTS 5300 saves the listing in the building memory 6216, and the LTS 5300 and the LTS 5300 returns the user to the building memory users choice menu 6218.

**[0536] FIG. 66**

**FIG. 66** displays the process to enter a "phone number" to the building memory. The LTS 5300 logs the user's entered listing and searches the crisscross phonebook with the lat/long correlations 2812 or address coordinates for all matching entries 6600. If the listing is not found 6602, the LTS 5300 notifies the user the listing is not found 6604 and the user is sent to the user choices menu 5502. If the listing is found 6602, the LTS 5300 displays all the entries that contain the entered "phone number" and the LTS 5300 prompts the user to select the desired entry 6606. If the user does not select a listing 6608, the user is sent to the user choices menu 5502. If the user



selects an entry **6608**, the LTS **5300** displays the selected listing on the display screen **2836** with the following information: name, category of listing, address, and phone number. The LTS **5300** plots and labels the listing location on a street map with the location of the wireless devices **6610**. The LTS **5300** prompts the user if he wants to save the listing in the building memory **6212**. If the user does not save the listing **6214**, he is sent to the user choices menu **5502**. If the user saves the listing, the LTS **5300** saves the listing in the building memory **6216**, and the LTS **5300** and the LTS **5300** returns the user to the building memory user's choice menu **6218**.

**[0537] FIG. 67**

The user's history report may be generated by building and/or retrieving case files that are generated at the time that communications are sent/received by the wireless device **104**, and which contain the location of the wireless device **104** at the time of the communication. This tracking method is best for tracking wireless devices **104**, which are used, on a frequent basis during the day.

**[0538]** Alternatively, the user's history report may be generated by building and/or retrieving case files by periodically (every hour, twice a day etc.) querying a user location database **900**, user location database coordinator **908**, or querying the wireless networks base station controller **118-A** or other network components, for the location of the wireless device **104**.

**[0539]** This alternative method of generating a user's history report would be preferred for locating/tracking wireless devices **104** that are not used frequently. If a wireless device **104** only receives one or two communications a day, a periodic report (every hour, etc.) would give a more complete report of the location of the wireless device **104** through the day.

**[0540]** A third method of generating a user's history report is to combine the two methods mentioned above. This involves reporting case files with call/location generated when the wireless device **104** sends/receives a communication, combined with the periodic case file, which is generated periodically (every hour, etc., depending on the selected monitoring period set by the owner of the wireless device **104**, the user of the LTS **5300**, or the wireless service

provider).

**[0541] FIG. 67** shows the process to display call history report. The LTS 5300 prompts the user to select a range of time the report will cover 6700. If the user does not select a time range 6702, the LTS 5300 will send the user to the user choice menu 5502. If the user selects a time range 6702, the LTS 5300 logs the time range 6704 and the LTS 5300 queries the ULD 900 or case file database that correspond with the selected phonebook entries and time range 6706. The ULD 900, GPS, or the BSC 118-A determine the lat/long of the case files 6708. The LTS 5300 correlation software converts the latitude and longitude of the case files to a postal address, cross street, business, government, house name 6710. The LTS 5300 prompts the user to select how he wants to sort the call history 6712. The user can sort the call history by: time of call, location of call, calling party, or wireless phone number 6712. If the user does not select a sort type 6714, the default sort type is used 6716. Otherwise, the LTS 5300 logs the users choice and displays the transcribed postal address in the selected order with the corresponding phone number, length of call, time of call, and calling party 6718. The LTS 5300 then prompts the user to select an individual call record that the user desires to plot on a map 6720. If the user does not select a call record 6722, the LTS 5300 asks the user if he wants to print the call history 6724. If the user selects a call record 6722, the LTS 5300 logs the choice and overlays the calls latitude and longitude location on a topographic street map 6726. The LTS 5300 then prompts the user if he wants to return to the call/location display screen 6728. If the user selects to return to the call/location display screen 6730, the LTS 5300 prompts the user to select a time range for the call history report 6732. Otherwise, the LTS 5300 returns the user to the users choice menu 5502.

**[0542] FIG. 68**

**FIG. 68** shows the process to print call history report. The LTS 5300 prompts the user to select a range of time the report will cover 6800. If the user does not select a time range 6802, the LTS 5300 will send the user to the user choice menu 5502. If the user selects a time range 6802, the LTS 5300 logs the time range 6804 and the LTS 5300 queries the ULD 900 or case file database that correspond with the selected phonebook entries and time range 6806. The ULD 900, GPS, or the BSC 206 determine the latlong of the case files 6808. The LTS 5300 correlation software

converts the latitude and longitude of the case files to a postal address, cross street, business, government, house name **6810**. The LTS **5300** prompts the user to select how he wants to sort the call history **6812**. The user can sort the call history by: time of call, location of call, calling party, or wireless phone number. If the user does not select a sort type **6814**, the default sort type is used **6816**. Otherwise, the LTS **5300** logs the user's choice and displays the transcribed postal address in the selected order with the corresponding phone number, length of call, time of call, and calling party **6818**. The LTS **5300** then prompts the user if he wants to print the history report **6820**. If the user does not print the history report **6822**, the LTS **5300** prompts the user if he wants to include the call history report on the user's phone bill **6826**. If the user prints the call history report **6822**, the LTS **5300** sends the report to the desired printer **6824**. The LTS **5300** then prompts the user if he wants to include the call history report on the user's phone bill **6826**. If the user selects to include the report with the user's phone bill **6828**, the LTS **5300** includes the call history report in the user's phone bill **6832**. Otherwise, the LTS **5300** returns the user to the users choice menu **5502**.

**[0543] FIG. 69**

**FIG. 69** displays the process to include the call history report in the user's phone bill. The LTS asks the user if he wants the call history report included in the billing statement. If the user chooses not to add the call history report **6902**, the LTS **5300** returns the user to the user's choice menu **5502**. If the user chooses to add the call history **6902**, the LTS **5300** logs the user's choice **6904**, and prompts the user to enter authorization information to verify he is the owner of the wireless device **6906**. If the user does not enter authorization information **6908**, the LTS **5300** returns the user to the user's choice menu **5502**. If the user enters authorization information **6908**, the LTS **5300** logs the authorization information and matches the information with wireless providers records **6910**. If the authorization information does not match the records **6914**, the LTS **5300** notifies the user of the mismatch **6916**, and returns the user to the user's choice menu **5502**. If the information matches **6914**, the LTS **5300** prompts the user to approve the charges added to the bill for the call history report **6918**. If the user does not approve the charges **6920**, the LTS **5300** returns the user to user's choice menu **5502**. If the user approves the charges **6920**, the LTS **5300** logs the user's choice and instructs the wireless service to include the call location history report to the bill **6922**. The LTS **5300** prompts the user if he wants to return the user's

choice menu **6924**. If the user selects to returns to the user's choice menu **6926**, the LTS **5300** returns the user to the user's choice menu **5502**. Otherwise the user is logged off the LTS **6930**.

#### **LOCATION TRACKING SYSTEM; SUMMARY**

**[0544]** The location tracking system **5300** is a method of determining the location and then tracking a single or plurality of wireless devices **104** on a given wireless device network(s) **100** based on a criterion provided by a user. Based on this criterion a log is created that record the location and network status of any wireless device **104** fitting the criterion. These logs are recorded to a database and then later transferred to a user database for storage on a local server database.

**[0545]** Accessing the database can be accomplished remotely or locally. Local access is from local service terminals on the network or mainframe. Remote access can be from a TCP/IP, IPX, Dial-up, remote server SQL Queries, and other listed methods. This allows for third party vendors to have access to the said primary embodiment **2800** features and use the technology to create product support and technological spin-offs. Examples of technological spin-offs would be; a cellular phone bill that gives the user's geographic location at the time of each logged call, an internet **3202** website that would allow business owners to track the location of employees or equipment comprising a wireless device **104**, or a geographical advertising system (GAS) that would allow targeted advertising based on the location of the user of a wireless device **104**. Many other technological spin-offs are also possible.

**[0546]** Tracking the wireless devices **104** can be done by utilizing a user location database (ULD) **900**, GPS data from the phone, direct analysis of the network communication parameters, or by other third party methods. When a wireless device **104** is not located on a local server a user location database coordinator (ULDC) **908** or other system can be used to discover the location of a device to allow a log to be created.

**[0547]** Logs can be created and appended as a wireless device **104** roams a local wireless device network **100** or a remote wireless device **1900** network. Using TCP/IP and ATM connections, servers for discreet wireless device networks **100** can communicate together and allow seamless

network interoperability. This allows the tracking logs to record the location of wireless devices **104** on a plurality of wireless device networks **100** having had a request generated from any network connected to the deemed wide-area network. Internet **3202** Protocol 6 and 7 should allow this to become even more practical.

**[0548]** Notification from the server to external programs, users, wireless devices **104** is a native capability of the said primary embodiment **2800**. The messages can be sent alerting the said wireless device **104** of a system event. A user sets up this event when the log setup process begins by the user. The user can have the system send an alert based on a criterion such as the completion of a log. The advantage is that an alert can be sent to external programs triggering an external event. This allows third party software to use this to create a new technology and create a new product for their consumers.

**[0549]** An example is for a wireless device user **102** to be tracked and logged. A message could be sent via SMS (simple message system) to a prescribed wireless device **104** when that wireless device **104** being tracked leaves a certain geographic region. The system would for example allow a parent to be alerted when their child is going somewhere they shouldn't.

**[0550]** The primary embodiment **2800** also describes a method for allowing a large volume of users to access the logging and tracking database. The primary embodiment **2800** describes the method that allows a large volume of tracking to be done and logged simultaneously. By making separate database structures on separate hardware entities the load is divided into active database buffers where logs being created are stored, to a separate structure where inactive logs are saved for users.

**[0551]** A graphical interface and display protocol database **3004** is described that allows users to interact with the system and remotely retrieve meaningful representations of the data from the logs. Tracking logs simply contain data that describes network parameters as well as geographic and timing information. Alone this data is simply text. The said graphical display allows a useful extraction of the data to be represented. Multiple logs can be shown with data overlays including maps, topological information **4160**, and other network parameters.

[0552] The physical structure for the wireless device network **100** is described in including the database hardware implementation, the networking implementation and the processing implementation. Examples of appropriate hardware and peripherals are given. Amounts of storage and hardware configurations are described. RAID architecture is listed and the preferred level of RAID deployment is also suggested for various deployments of the primary embodiment **2800** based on budget and performance.

[0553] A major user interaction of the primary embodiment **2800** is envisioned, but not excluded to, the ability to track and record wireless devices **104** that users have administrative control over. This would allow them to monitor, record, and review where and how their wireless devices **104** are used. Uses could be to monitor the location of workers, children, demographically defined users, and other types.

[0554] Monitoring wireless devices **104** by demographics has the unique ability to allow business to discover the location and moving habits of its customers. An example of this would be for a company to track all wireless devices **104** based on a set of demographic criterion that matches its target audience. The system would then track all wireless devices **104** matching those criterion and record the locations to a server database log, allowing the company to find a location to possibly build a new store that would maximize its exposure to its target customers.

[0555] Another use would be for a company to search for customers (based on a local mailing list of customers phone numbers) and when the customer enters a region (geographic distance) from the store location, a log would be created. A page or message could be sent to an external program indicating the event. A subsequent push' message technology such as SMS could be used to deliver content to the wireless device **104** in the form of an advertisement. This technology would allow the company to restrict its advertising to valid customers of interest and reduce the costs of advertising.

#### DESCRIPTION OF EMBODIMENTS

[0556] Device Tracking and Logging

The wireless device **104** tracking and logging option of the location tracking system **5300** is used to monitor and record the location (latitude/longitude/altitude) of a wireless device **104** over a period of time. The feature requires the use of the device location software **2808**, location database manager<sup>904</sup>, as their associated components. For a wireless device **104** to be tracked it must be able to be recognized by the system. The device location software **2808** allows for a wireless device **104** (wireless device **104**, 2 way pager, satellite phone, GPS enabled device, wireless LAN device, other) to be tracked as long as the system can access the control hardware/software for the appropriate wireless device network **100**.

[0557] For GPS satellite network **114** enabled devices, certain considerations must be taken into account due to the nature of multi-path in cellular environments. Multi-path is the error caused by reflected signals entering the front end of the receiver and masking the real correlation peak. In this case, signal from the GPS satellite network **114** to the wireless device **104**. The effects tend to be more pronounced in a static receiver near large reflecting surfaces, where 15 m in or more in ranging error can be found in extreme cases. In this case, a wireless device **104** slightly indoor or in a city between buildings would be relevant. Monitor or reference stations (in this case the BTS **118-A** of the wireless device network **100**) require special care in placing (the BTS's **118-A**) to avoid unacceptable errors.

[0558] The first line of defense is to use the combination of antenna **2430** cut-off angle and antenna **2430** location that minimizes this problem. It however is not always possible in a wireless device network **100** and can cause undue or uneven accuracy in location ability over a wireless device network **100**. A second approach is to use so-called "narrow correlator" receivers that tend to minimize the impact of multi-path on range tracking accuracy's. The approach does not apply to wireless device networks **100** and should not be used. Overall the effects of GPS satellite network **114** error still allow the most accurate location results. But consideration for its inaccuracies should be noted.

[0559] The wireless devices **104** that can be tracked are limited to the wireless device networks **100** the device location software **2808** is attached to. A noted exception is when a ULD **900** or ULDC network **1600** (or similar) is available for the system to query. In this case the wireless

device **104** will be able to retrieve the location of any wireless device **104** that exists in the database regardless of the type of network it is operating on. The design would be preferred because it creates a type of universal standard that would allow a plurality of wireless devices **100** to be tracked over a variety of networks.

**[0560]** A further requirement for the wireless device **104** to be tracked is that the attached network or ULD **900**/ULDC **908** to the location tracking system **5300** is capable of being polled (by software means) for locations of wireless devices **104** at regular intervals as short as less than one second or as long as many hours. The necessary hardware must exist on the wireless device network **100** to accommodate the required bandwidth and pipe-lining of multiple simultaneous requests for the location of a wireless device **104**.

**[0561]** When no database such as an ULD **900** or ULDC network **1600** is available, the attached networks are required to provide the following elements from internal registers pertaining to an attached wireless device **104** on the wireless device network **100**, as to allow the location tracking system **5300** software to calculate a location for the wireless device **104**:

Base station(s) **118-A** or antenna(s) **2430** location for all network equipment communicating with the wireless device **104** and; The round trip delay time for communications between the network antenna(s) **2430** and the wireless device **104** and/or;

The signal receive strength from the wireless device **104** to the network antenna(s) **2430** and/or;

Other location assisting information

**[0562]** When these design requirements on the network side are available then the location tracking system **5300** is capable of tracking a plurality of wireless devices **104** and recording user records **5312** to an internal/external database that includes the location referenced to time for the said wireless devices **104**.

**[0563]** The location tracking system **5300** software first utilizes the display screen **2836** to display a menu to the user on their display screen **2836** of the wireless device **104** they are



accessing the system from. The menu asks for the user to enter a single or list of wireless devices **104** to be logged. It also asks for a time frame to track these wireless devices **104** for. The time frame can be from the current system time to any given time. It can also begin at a future time and then end at any arbitrary time. Additionally, it can offer a log to be generated that includes only the location and basic other information (1 second duration or other short time). The location tracking system **5300** software would allow subsequent database queries to retrieve call location for all calls to a wireless device **104**. Hence, an additional option that allows a log to be generated for all calls by a wireless device **104** for an indefinite time period is also required.

**[0564]** The user then can specify the log entry filenames for the database entries. When the user enters this information they are prompted with alerting options. These options include the user to be sent a message in the case of a set criterion is met. The user can then enter a list of criteria. These include:

Geographic boundary that wireless devices **104** cannot exceed/enter Distance wireless devices **104** may travel from any user defined location If a wireless device **104** comes within in some distance of a user defines location

**[0565]** When these criteria are entered the user enters their contact information. The location tracking system **5300** will alert the user if any criterion are met and include a message that indicates the wireless device **104** name and database entry that may be viewed to retrieve the results. The alerting options may take any of the following forms but are not limited to:

Email

SMS messaging

Website posting

Online messaging

Page

Text messaging

Automated voice call (synthesized voice) to a voice line Fax

Other messaging protocols that can send to wireless devices **104**

**[0566]** Once the user selects this option the system can ask the user to review the choices. The

user approves them, then the system sends the criteria to the location database manager **904**. The users selected wireless devices **104** will be tracked for the remainder of the selected times. The user connects and they also review a list of active logs and cancel the logging or change the parameters and resubmit them to the location database manager **904**. The system will overwrite the old tracking options for any modified wireless device **104**.

**[0567]** The location database manager **904** now adds the wireless device **104** names (and corresponding wireless device identification **3724** information) into its location queue. The location queue contains the wireless device identifiers **3724** of all wireless devices **104** being logged. The location database manager **904** cycles through the list and determines the location of each wireless device **104** at the said time, and stores that information to a database record as named by the user in the setup.

**[0568]** When a new entry is added to the queue a database entry is established and necessary disk space is allotted for the duration specified by the user. The process assures that the system will not have to slow down to a lot more space later. The database disk space reserved is equal to the data storage rate times the file size per location query times the tracking time plus overhead for the database file entry.

**[0569]** The queue is automatically cycled though. Its size is dynamic because entries to it are constantly being made. Additionally, entries are always being removed from it. As the time(s) for entries to stop recording, as entered by a user, are met, and entry is removed from the queue. The database entry is then moved to a storage database on a different physical medium. The disk space on the primary databases physical drive is then free to be recorded to by a new record.

**[0570]** Users may now access any records on the second database. They may also access records for location tracking(s) in progress. When this occurs the location database manager **904** overwrites the end time to the current time. The location database manager **904** then creates a new entry that starts at the current time and ends at the original end time. The result is that on the next cycle through the queue the record would be stored (up to the current time) to the secondary database so that the user could access the tracking information up to the current time.

[0571] When a user retrieves the user record(s) **5312** the display software **2832** generates a map that covers the geographic boundaries of the users record(s) **5312** being opened. To display the user records **5312** the following information is needed:

- Geographic database **4160**
- Metropolitan road database
- Building location database
- Topographic information **2810**
- Other

[0571] The information is then correlated to the user records **5312** based on the location in terms of latitude and longitude (and possible altitude). At this point the display software **2832** overlays this onto the user records **5312** and displays this information to the user. The user may zoom in and move the geographic boundaries. The resolution of the record will be limited to the time between updates and the distance traveled between those times by the wireless device **104**. Mathematical extrapolations for missing data can be made by commonly known techniques to approximate the location between samples.

#### **Location Database Logs**

[0572] Logs created by the location tracking system **5300** software and database management software must have a consistent format that will allow universal parsing of the formatted data. The content listed in the logs must allow for a complete list of descriptive data to be saved and stored in an efficient manner.

[0573] When the data is stored to the logs key elements. are required to identify the logs owner and relevant network identifiers. The requirements to establish this are the following categories:

- User identifier
- Home network for user
- Current network log is being generated on
- User's permanent storage location

[0574] The next elements listed in the database log are the elements that will be tracked. These

elements will be listed under categories in the log to allow rapid parsing of the log by software after it has been created and stored to a user's local directory of sectionalized portion of a home database structure. The categories are:

- Device ID numbers **3724**
- Network hardware ID numbers
- Event ID numbers

**[0575]** The device ID numbers **3724** correspond to a unique identifier that is assigned to every wireless device **104** on a plurality of wireless device networks **100** that identifies itself and the wireless device network **100** it is on (ESN number, HEX ID code, wireless device **104** number, etc). The network hardware ID numbers are the identifiers of specific radio tower with BTS **110** or radio tower network **105** side equipment that communicates with users. Listed hardware elements here allow all wireless devices **104** communicating with these network components to be logged. Event ID numbers correspond to system events that would allow subsequent tracking of wireless devices **104**. An example is when a wireless device network **100** fault occurs the system will monitor the wireless device **104** that the fault occurred on.

**[0576]** The log has a start and stop time stamp field additionally that allows the date and time of the logs creation and completion to be noted and parsed quickly. Additionally there are time stamps for all recorded data.

**[0577]** The next fields are data log fields. In this section there exists only wireless device ID numbers **3726** because only wireless devices **104** are ever tracked. The structure of this field is:

- Wireless device number **3726**
- Tracking reference ID
  - a plurality of data measurements (taken at sequential times)
    - o Location of device (GPS data or latitude/longitude)
    - o Time of measurement
    - o Date of measurement
    - o Other
      - Network parameters

- Wireless device 104 statistics
- Etc

[0578] There can be many wireless device numbers **3726** in the log as well as many data measurements for each wireless device **104**. The structure allows a plurality of wireless devices **104** to be listed and for each wireless device **104** to have independent amounts of data written to it. The tracking reference ID number allows for a link to the initial reason the wireless device **104** was tracked. An external query can just look for wireless devices 104 with respect to initial tracking criteria. For example, if a criterion was to monitor all wireless devices **104** on 2 physical radio tower network **105**, then a tracking reference ID would be associated with that and affixed to every wireless device **104** log that was created for that reason. The tracking elements each have pre assigned ID numbers that are given by the database manager software and the software then also puts the same ID on each relevant wireless device **104** tracked corresponding to the tracking requirement.

#### **Cumulative Reports for Devices**

[0579] The idea of a cumulative report would be to allow a user to retrieve information on a plurality of database log entries made on a specific or plurality of wireless devices **104**. The reports could be extended to include details on all call activity on a wireless device **104** by allowing that wireless device 104 to have a log generated each time an active call is made. The location tracking system **5300** software is designed to allow this to happen. A short duration track occurs for every call that is made from a wireless device **104** and stored a personal storage space on the secondary database used for user long-term storage.

[0580] The qualifications placed on all tracking a wireless device **104** are that the wireless device **104** must verify a location and all call activity must be valid on the traffic channel. The qualification would exclude certain types of calls from being recorded. In general these calls would not show up as billable calls and would result in a user not being able to even initiate a voice channel on the phone.

[0581] Their duration are typically less than one second. Examples of situations that would not

record data including location of a wireless device 104 are:

- Network Access Failures
- Drop Calls before call is established on Network
- Poor Physical channel properties resulting in a call/network time out
- Hard Block
- Soft Block
- Capacity Block

[0582] All calls that are successfully initiated on the wireless device network **100** will have a location database log created by the location tracking system **5300** software, and subsequently user location database manager **904**. All the logs are then stored into the user directory.

[0583] A possible use of this data is for it to be included in billing data. The user would receive a bill from the wireless device **104** carrier they use that could include call location information on where every call was initiated **6904**. The caller ID features could allow the system to retrieve the number of the phone that was incoming or the outgoing phone dialed. This would also allow the location of that wireless device **104** to be noted.

[0584] The location of the user's wireless device **104** when the call was made would be accomplished by parsing the user's database **3216** by means of SQL techniques or by other database query tools commonly known. Each call logged would be referenced to other call information including time and date. They can then be referenced to calls listed on the billable statement sent to the user. The location would be recorded as a latitude and longitude location. If a user elects the system could convert this to a landmark location or address by referring to a criss-cross latitude longitude map/database. The nearest address could be listed. An additional option would be to list a general area as opposed to an address which could often be incorrect due to location accuracy.

[0585] The dialed number (for outgoing calls) or incoming caller's Id (for received calls) could also have a location listed. To accomplish this, the remote wireless device **1900** would be determined if it is a land line **142** device or a wireless device **104**. If the device is a land locked

device than an address for the phone number will be available through a database from the phone service provider of the number.

**[0586]** If, however, the device is a wireless device **104** unit then this will not work. The wireless device **104** will have to be queried remotely. In this case the system can use an ATM, I based, or other method to query the main service provider of the wireless device **104** for the user location database **900** entry for that user. If authentication is allowed, and a log was made for a call at that time then a location would be available. The location could then be added to a billing cycle.

**[0587]** If as in many cases, the remote wireless device **1900** had no call log made, then the wireless device **104** location can only be guessed upon. The system would have to resort to the users "home" NID and then supply that to the querying system. The NID could be resolved into a city, state, geographic region. The information would be included in the billing cycle as an approximation of the user's location. An appropriate consideration would be to inform on the billing cycle that is location is inaccurate and only an approximation and could be incorrect.

**[0588]** An additional use of a cumulative report would be for an external query to be made on a plurality of logs. The logging criteria could list any data field include wireless device identifiers **3724** (ex: phone #'s), logs from geographic regions, etc. The query could be remote or from an internal memory storage **2818** system. To make this possible, the external query would have to be IP base, ATM, or another universal standard that would allow a plurality of users access to the system and provide a secure data transmission.

**[0589]** The filter can then derive only the logs for a given user, or group of users, personal database folders. The results would then be returned and could be listed either textually or graphically to the user. A text representation would be for a list of database entries that met the specifications to be listed on the screen. A graphical representation could be to plot a map and indicate log locations on it. These options are described in the data log graphical display section.

#### **Data Log Graphical Display**

**[0590]** The user may parse a tracking log in their personal database. These logs will contain the

location tracking system **5300** information for anything the user requested from the location tracking system **5300** software. The user can read this information after it is parsed in text form however a series of latitudes and longitudes will simply be repeated at the update intervals for each time a location was determined. The series of latitudes and longitudes is not very valuable to a user in general. An easy way for the user to gain valuable insight is to display this information on a graphical display unit. This could be a monitor or other display hardware attached to the querying device. It could also be a hard copy reproduced and printed on a printing device.

**[0591]** The log can be parsed and converted to a graphical display for the user by the following method. First, the database entry must be scanned and read all the correlated data for latitude and longitude information **2830** for the tracked wireless device **104**. The most extreme dimensions in for example, east, west, north and south (using Cartesian coordinates) will be noted. In this case you could also use any other dimensionally system convenient (radial, spherical). The extreme locations will be the boundaries of the displayed map. The data points will be plotted on that map, correlating data for latitude and longitude information **2832** to the correlated pixel separation as correlated to the scale of the map. The minimum resolution is the pixel separation at the monitors screen resolution. The distance will be used to disregard location points at distances less than a given amount.

**[0592]** The plotting system can then plot the remaining points to the display screen **2836**. The system will then have a map with the data points plotted to it. To increase accuracy the system may also be able to provide the described functionality that is not common knowledge. All roadways and transportation ways will be illustrated and correlating data for latitude and longitude information **2830** on the map. If a wireless device **104** is traveling in a direction for a given distance and follows a road way but is not on it exactly the software could assume the wireless device **104** is on the roadway and re-center the data points on the roadway to increase accuracy.

**[0593]** The plotting system would allow the system to more accurately display a tracked wireless device **104** to a user. When the location of this wireless device **104** is plotted it would not show



the device passing through buildings or other objects and allow the location of the data point to be shifted to the adjacent roadway or habitable area. Definable parameters would be the distance traveled along a roadway and the distance away from the road way that the software could use as criteria to assume the wireless device **104** is on the road. The distance should be conservative as to prevent obscuring real locations. An appropriate distance could be from 5meters to 100 meters depending on the tuning of a network engineer for a particular situation.

**[0594]** Displaying the wireless device **104** travel vector may also be useful. This Would allow the user to see the relative travel direction and speed of the wireless device **104**. To accomplish this, the system would sample a defined parameter that represents how many data points to average. If the software averages 20 data points then the average direction and velocity would be represented by a vector on the display. The foot of the vector would be at the mean location of the sample range, and the vector length from foot to tip would be proportional to the average velocity over that sample time. The vectors would be plotted for every group of data points. The group size could be adjustable by the user and is accomplishable through any data interface.

**[0595]** Another display option would be for the user to have a real-time replay of the user's location. The display could be accomplished by plotting points to the screen at the minimum pixel separation over the time interval shown. The plotting is easily done and would give the user a perspective of where the user was at various points in time. A text information box can then additionally show the time during the call while points are being plotted.

**[0596]** The display software **2832** that gives the GUI and mapping ability can also show a plurality of log locations for a plurality of log database entries. The mapping can be accomplished by, as before, scanning logs for extreme distances. In this case though, all logs that are selected would have to be scanned for their maximum geographic dimensions. Once this is done, a map could be generated based on the dimensions. The overlay for the logs would be definable by programming, but a convenient method is to determine the initial starting location of each call and then to plot these points for each call on the map.

**[0597]** The user may select points and then the entire route can be plotted on the map. The user

who wants more detail may zoom in. The new dimensionality of the map would require the minimum pixel separation to be re-computed and would then allow more detail or less depending on if the user zoomed in or out.

**[0598]** Alternate method that could be used if more detailed location information is available in future network configurations would be:

- Plotting altitude
- Inside building location
- Plotting call detail (logged speech)

### **Inter Network Communication**

**[0599]** To make the location tracking system **5300** available to other networks outside any single entity, a database sharing system must be established. A most likely case would be for a system such as an ATM routing center or an IP (connectionless) based system to be used.

**[0600]** The first system is beneficial in cases where a large number of database queries may be made. ATM switching allows for a dedicated path to be established between host and user sites and allow a rapid connection once the line is established. Basic benefits to consider when choosing ATM switching are:

- High performance via hardware switching
- Dynamic bandwidth for busy traffic
- Class-of-service support for various traffic type
- Scalability in speed and network size
- Common LAN/WAN architecture
- Opportunities for simplification via VC architecture
- International standards compliance

**[0601]** The benefits of IP switching as opposed to direct ATM connections between wireless device networks **100** are that the complexity is reduced. You only route packets to the next routing point and can take advantage of preexisting hardware on other networks to get your data to the destination, in our case the other wireless device **104** network. The ability to handle

security on a traditional router basis is very complex and the speed at which a router switches or routes a packet is very slow and cumbersome because every packet has to be looked at as it goes through the wireless device network **100**. This can reduce security and is a consideration for any wireless provider when implementing IP switching. With an IP switch (MTX or other) 130-based network, what happens is the first packet is looked at and the supplementary packets do a quick forward look-up and then everything else goes through the network very, quickly, so it's less costly and it's easier to administer.

**[0602]** ATM systems require new and expensive hardware to be added but are often faster and more reliable. The system is also a far more secure method because all information is on a protected network at all times. IP based system here could use the internet **3202** to send requests between wireless device network **100** locations and allow for rapid development and low cost of implementation.

**[0603]** The inter-network structure would allow wireless device networks **100** to query each other for information. Security and fire-wall precautions aside, this allows one wireless device network **100** to retrieve the location of a wireless device **104** on any other wireless device network **100**. The inter-network structure would allow the tracking of the two, or more, wireless devices **104** on a call or other communication. It would also allow tracking wireless devices **104** as they moved off of a network providers system and on to a remote system. IP version 6 provides for the internet **3202** solutions to inter-network wireless device **104** movement and would allow tracking to occur over multiple wireless device networks **100**.

**[0604]** The data logs could then be generated at the remote wireless device network **100** and retrieved by the user's home wireless device network **100**. This would allow tracking beyond the users own network boundaries.

Security

**[0605]** The security of this wireless device network **100** can be viewed in two subsystems. First the network must secure access to the system at a user level access, or group access scheme. Second, the system must secure user system rights. In this regard, it must secure that any user

may not gain access to sensitive information of another user it does not have rights to.

**[0606]** The access of a user to the system will be defined and can be implemented by various methods. Secure Socket Layer (SSL) can be used to guarantee that an external wireless device user **102** has a secure connection. Modern internet **3202** browsers use a SSL to encrypt the information that flows between the browser and the web server. A browser using SSL has established a secure encrypted connection with the server, meaning it is safe to send sensitive data. In the case of a local connection less line security is necessary. 128 bit or higher encryption of data across a wireless device network **100** will allow data to remain private in transit.

**[0607]** To allow for a secure connection various protocols can be used. FTP, and telnet offer some protection, but secure connections such as used by verisign and other companies to establish "user identity" are recommended. The connection types should be connectionless service types. The secure connection ensures that packets never follow the same path across a network such as the internet **3202**. The secure connection allows for less possibility of snooping and more security. On secure connections (point-to-point), connection oriented ATM links can suffice because the line is secure in a physical sense.

**[0608]** Wireless device users **102** will be placed in categories based on access rights. All three categories are defined by an administrator and are adjustable, but generally accepted standards are:

- User
- Super user
- Administrator

**[0609]** A user level access will give the entity connecting to the system the ability to access only files created and stored in its user directory. The user may only request logs be created for wireless devices **104** that have been added to its authorized list by an administrative account.

**[0610]** A super user has access to all the user rights for itself, but may also have rights to the files

and permissions of a group of wireless device users **102**. This would allow the user to track wireless devices **104** listed on other wireless device users **102** accounts.

[0611] An administrator has all the access of the super user but also has the ability to create and delete accounts, as well as file management. This allows the administrator unrestricted access to all files on a server. It can also alter and change system parameters that affect any or all wireless device users **102**.

### **Physical Hardware to Realize Embodiment**

[0612] To implement the primary embodiment **2800** there must be a hardware platform for the software to function from. The term function refers to the normal operation of the software that includes the primary embodiment **2800** as well as any other secondary software packages that would run to assist the primary embodiment **2800**. The secondary processes are commonly known and would not be covered by this patent. An example would be dynamic link libraries that are commonly known and used to linking various software elements.

[0613] The hardware required to implement the user location database manager **904** is inclusive of but not limited to, based on any unique hardware setup:

- Data storage medium
- Data storage controller (RAID, etc)
- Computer **2910** (includes motherboard, CPU, RAM, etc)
- Network interface card

[0614] The data storage medium should consist of a hard disk or other nonvolatile storage medium that is can be accessed by a computer **2910**. It can conform to either, IDE or SCSI standards. Extended standards could include ultra wide SCSI and EIDE as well as other derivations. The claimed scope is that a communications protocol database **3004** and physical layer would provide high bandwidth capacity and high efficiency. Examples of this hardware may be a western digital 10,000 RPM 80GB deskstar hard disk drive.

The data storage controller consists of one of the following generic classes:

- IDE/EIDE/etc
- SCSI/U W-SCSI/etc
- RAID type 1, 2, etc

**[0615]** The controllers are required for the computer **2910** to be allowed to access the hard disk drive. To allow for this to work the computer **2910** must be compatible with the controller. The RAID controller allows a unique benefit to the database and storage architecture. Having many configurations, very high bandwidth and redundancy of data is possible. The accurate usage of RAID architecture is critical for these databases as VERY high bandwidth is required on large wireless device networks **100**. Explained as follows are the recommended RAID types and the considerations in choosing each.

**[0616]** In RAID 0, the controller will store the data across two or more disks, writing the data in blocks across the disks. For example, if you have two disks, block one will be written to disk one, block two to disk two, block three to disk one, and so on. The data will increase performance since the controller can read/write in parallel, but there is no redundancy, if one disk fails, the whole array fails, since the data is spread across the array. RAID 0 is the most efficient level in terms of cost/space/performance, as you will increase performance without sacrificing any disk space, though access times suffer slightly. RAID 0 is best used where cost/performance is critical, but data integrity is not. For this reason the type of RAID would be the least recommended for the primary embodiment **2800** and its databases.

**[0617]** A RAID 1 array consists of two or more disks and acts as one logical disk while mirrored data **1532** is passed between the disks. If you have an array consisting of two 36 GB disks, you will end up with a logical disk of 36 GB, with data being stored on both the physical disks. Hence one of the physical disks can fail, and the array will keep working, and if the disks are hot-swappable, which is the case with most SCSI RAID setups, the failed disk can be swapped for a new disk, and the controller will synch the data between the disks, restoring the array to full functionality, with no downtime. RAID 1 also increases the read performance since both disks can be read at once, while write performance will be more or less identical to that of one single

disk. RAID 1 is a way to achieve good read performance, as well as redundancy. For this reason it is recommended over RAID 0 and will allow higher bandwidth and therefore more throughput from the database to the computer **2910**

**[0618]** Striping with parity increases performance while maintaining a handle on redundancy. RAID 3 does this by implementing a RAID 0 and then creating a separate disk to write parity information. RAID 3 helps, if you lose a disk, that disk's information can be recreated. RAID 3 works on a binary system. (i.e. 11=0parity, 00=0parity, 01 =1 parity, 10=1 parity) You can take any two bits, and recreate the lost one. The benefits of this are performance and safety, although with RAID 3 you put a large strain on the odd disk that contains parity as everything has to be calculated and written to it. For every bit written to any other disk, one gets written there, both bottlenecking performance, and creating more strain on this disk. RAID 5 is considered to be a much better option. A required minimum of 3 disks, and an odd number of disks. RAID 3 is very expensive in terms of CPU power when implemented in software. For this reason this configuration is recommended over RAID 0 but less than RAID 1 for the primary embodiment **2800**.

**[0619]** RAID 5 is a quite common type of RAID but it doesn't offer the performance of RAID 1+0, but is much cheaper. Three or more disks are required for a RAID 5 array. RAID 5 stores parity information (unlike RAID 1 which stores data redundantly) across the disks in the array, this information can then be used to rebuild lost data in case of disk failure. RAID 5 is not recommended at all but is explained such that RAID 5 can next be fully understood.

**[0620]** RAID 50 is the combo of RAID 5 and RAID 0. The major benefit is speed. RAID 50s take the data to write, say 256k, then split that among the RAID 0, so 128k + 128k, then split that among the RAID 5s, so you could be writing 32k + 32k + 32k + 32k + 32k + 32k + 32k + 32k all to separate disks at the same time. The same is true in reverse as well for reading. You could also lose 1 disk out of each array and the controller would keep running. You can stream high amounts of data to several machines at once over the network. To do it right it really should be done on two controllers, or one multi-channel controller to give the arrays as much bandwidth as possible. RAID 50 requires a minimum of 6 disks, and an even number of disks. The setup is

recommended for the database controller. The system will be able to keep up with network connection bandwidth (T-1, T-3, OC-3, etc). The primary embodiment **2800** will operate at maximum efficiency using this setup.

**[0621]** The physical hardware should consist of a processor capable of computing the necessary work load. A dual processor system would reduce the load further. An intel XEON system (dual processor) at 1 GHz or above would suffice. Additional RAM in excess of 1 G would be beneficial and allow fast access to cached data. Similar systems to this are produced by AMD and other chip manufacturers.

**[0622]** The location tracking software **5300** may exist on any of the above said hardware but should have its own reserved storage medium. A low bandwidth connection to the computer **2910** is OK because the software will run from cache memory as it is a static program that is accessed frequently.

**[0623]** The display software **2832** does not require a specific set of hardware, more of a class of hardware. The display hardware **2832** required is a display driver or graphics hardware controller, commonly called a graphics card. Performance of the card need not be high but should allow for an adequate resolution display for the minimum programming of the display software **2832**.

**[0624]** Display hardware **2832** that could be used as the physical display device can be CRT computer **2910** monitor displays, LCD displays of various sizes including palm-top sized displays. Example of this is a Viewsonic 19" CRT G790, this monitor would support up to 1600x1200 at 80Hz refresh which would allow proper viewing of all visual data from the preferred embodiment **2800**

**[0625]** The network interface cards required would be a 121100 base-T or higher connection. Hardware such as a 3COM Etherfast NIC would function properly. External connectivity to the internet **3202** or other high speed data access points is also required which often requires a ATM connection or other gateway routing wireless device **104**.



**[0626] Directional Assistance Network (DAN)**

***THE DAN COMPRISES:***

- A COMPUTER SYSTEM HARDWARE/SOFTWARE
- AN OPERATING SYSTEM
- A DIRECTIONAL ASSISTANCE OPERATING PROGRAM
- AN AUTOMATED TELEPHONE HARDWARE/SOFTWARE
- A VOICE RECOGNITION HARDWARE/SOFTWARE
- TRAFFIC MONITORING AND ROUTE PLANNING HARDWARE /SOFTWARE AND MAPPING HARDWARE/SOFTWARE
- A WIRELESS DEVICE USER LOCATION DATABASE AND DATABASE LOGIC CENTER HARDWARE/SOFTWARE (OPTIONAL IF LOCATION DATA IS OBTAINED FROM AN OUTSIDE DATABASE, E-MOBILITY, ETC.)
- A PSTN USER LOCATION DATABASE AND DATABASE LOGIC CENTER HARDWARE/SOFTWARE (OPTIONAL IF LOCATION DATA IS OBTAINED FROM AN OUTSIDE DATABASE, E-MOBILITY, ETC.)
- LOCATION CONVERSION HARDWARE/SOFTWARE AND DATABASE TO CONVERT STREET ADDRESSES TO LONGITUDE AND LATITUDE DATA, AND TO CONVERT LONGITUDE AND LATITUDE DATA TO STREET ADDRESS DATA.
- A VOICE MAIL SYSTEM
- INTERNET ACCESSABLE
- INTERNET ADDRESS AND WEBSITE.
- ABILITY TO MAKE AND SENT MAPS TO WCD, NAVIGATIONAL SYSTEMS, FAXES, E-MAILS, ETC...
- A LIVE OPERATOR WHO CAN ACCESS, PROGRAM AND SERVICE ALL PARTS OF THE DAN.
- CONVERSION/STANDARDIZATION HARDWARE/SOFTWARE FOR INTERFACING WITH WIRELESS NETWORKS, WIRELESS DEVICES AND PUBLICLY SWITCHED TELEPHONE NETWORKS.
- CONVERSION/STANDARDIZATION HARDWARE/SOFTWARE FOR SENDING AND RECEIVING MAPS, E-MAILS AND FAXES.

### **Detailed Description of the Embodiments**

[0627] **FIG. 70** is a flowchart of the Directional Assistance Network (DAN) query process. To begin the query process, a person seeking directional assistance or location information begins a query for directional assistance by dialing a specified phone number, such as, for example, 411, 511, an 800 number or a dedicated button on a wireless device, navigational system or a land-based communications device **7000**. The user may also process a DAN query via the Internet. The user can enter his DAN query via a keypad or keyboard, through the use of voice recognition software, a live operator or by way of an interactive display screen, such as may be found on a wireless device or a navigational system. The process begins when the DAN **8100** receives the user's call **7002**. The DAN **8100** then queries a user location database (ULD) to determine the user's location and logs to user's location within the DAN **8100**, **BOX 7003**.

[0628] Still referring to **FIG. 70**, **BOX 7003**, if the DAN **8100** determines that the user is calling from a wireless communication device (WCD) **8205**, such as, for example, a cellular phone, an Personal Digital Assistant (FDA), wireless navigational system, etc, then DAN **8100** queries a wireless network's ULD **900** in order to determine the user's location within the wireless network. The wireless network's ULD **900** can exist internally to the DAN **8100** and constructed by the DAN **8100** with information obtained from the wireless network through querying the wireless network's e-mobility services, switch and/or base station controller. The DAN **8100** could also find the user's location without a wireless network's ULD **900**, by retrieving the user's location data from the wireless network on an as needed basis. The DAN **8100** can generate the location on an as needed basis by accessing pertinent location data, which can be obtained from the switch (MTX or other) **130**, and the base station controller (BSC) **206**. The pertinent information would include the round trip delay (RTD), signal strength and other factors needed for determining location of wireless device, which are disclosed in an attached document. The ability to determine the user's geographic location in the form of longitude and latitude data, when calling from a wireless device, is disclosed in an attached document entitled, 'A machine for providing a dynamic database of geographic location information for a plurality of wireless communications devices and process for making same'. This document referenced above, is a United States Provisional Patent, U.S. Serial Number 60/327,327, which was filed on October 4<sup>th</sup>, 2001, is hereby incorporated into this disclosure. Also, the wireless network's ULD **900** may

be comprised of only a single service provider's network, or in may comprise a plurality of service provider's networks data regarding wireless device user location data. The DAN **8100** may use its conversion/standardization hardware/software **8160** to interface with wireless networks and wireless devices.

**[0629]** Still referring to **FIG. 70, BOX 7003**, if the user's call originates from a publicly switched telephone network (PSTN) **138**, the user's location can be determined by querying a PSTN phone location database **8145** which consists of listings of the names of businesses and private residences, their respective street addresses, city, state and corresponding longitude and latitude coordinates, and their telephone numbers. The PSTN phone location database **8145** could be internal or external to the DAN **8100**. The database could also be comprised of a street map location system instead of a longitude and latitude based system. The DAN **8100** could also find the user's location without a PSTN's phone location database **8145**, by retrieving the user's location data from the PSTN **138** on an as needed basis. The location can be generated on an as needed basis within the DAN **8100** by accessing pertinent location data, which can be obtained from the switch (MTX or other) **130**, and the base station controller (BSC) **206** of the PSTN **138**. The DAN **8100** may use its conversion/standardization hardware/software **8160** to interface with the PSTN **138**.

**[0630]** Regardless of whether the user is calling form a wireless device or a landline, once the user's geographic location has been determined and logged into the DAN's voice mapping software **8110**, The DAN's automated telephone system prompts the user with a menu of services **7004**. Still referring to **FIG. 70**, the DAN **8100** first asks the user "If you know the phone number of your desired destination, and would like to receive directions to that destination, please press or say 1" **7006**. The automated telephone system waits for the user's response **7008**. If the user selects "1", the user is forwarded to **FIG. 71, BOX 7100**, the portion of the query process that retrieves the geographic coordinates of the users destination, based on the destination's area code and telephone number **7010**.

**[0631]** Again referring to **FIG. 70, BOX 7008**, if the user does not select "1" within a specified period of time, the automated telephone system continues to instruct the user "For the telephone

number and directions to a specific business or person by name, press or say "2" **7012**. The automated telephone system waits for the user's response **7014**. If the user selects "2", the user is forwarded to **FIG. 72, BOX 7200**, the portion of the query process that retrieves the business or residential listing by the name of the listing **7016**.

**[0632]** Still referring to **FIG. 70, BOX 7014**, if the user does not select "2" within a specified period of time, the automated telephone system continues to instruct the user, "For a phone number and directions to the nearest business by category, such as for example, a gas station or restaurant, press or say "3" **7018**. If the user selects "3", the user is forwarded to **FIG. 73, BOX 7300**, the portion of the query process that retrieves the geographic coordinates of the users destination, based on the category of the business which the user wishes to find **7022**.

**[0633]** Again referring to **FIG. 70, BOX 7020**, if the user does not select "3" within a specified period of time, the automated telephone system continues to instruct the user, "For a phone number and directions to as specific address, press or say "4" **7024**. If the user selects "4", the user is forwarded to **FIG. 74, BOX 7400**, the portion of the query process that retrieves the geographic coordinates of the specific address the user is requesting directions and the phone number **7028**. Still referring to **FIG. 70, BOX 7026**, if the user does not select "4" within a specified period of time, the automated telephone system continues to instruct the user, "To locate or track a wireless device, press or say "5" **7030**. The DAN **8100** then waits a specified period of time for the user to respond by selecting "5" **7032**. If the user selects "5", the user is forwarded to **FIG. 78, BOX 7800** and the DAN **8100** continues it's query process **7034**.

**[0634]** Again referring to **FIG. 70, BOX 7032**, if the user does not select "5" within a specified period of time, the automated telephone system continues to instruct the user, "To repeat these choices, press or say "6" **7036**. The DAN **8100** then waits a specified period of time for the user to respond by selecting "6" **7038**. If the user selects "6", the user is returned to **FIG. 70, BOX 7006**, the portion of the query process which has been described above is repeated **7032**. If the user does not select "6" within a specified period of time, the automated telephone system continues to instruct the user, "To end this call, press or say "9", or hang up" **7040**. The DAN **8100** then waits a specified period of time for the user to respond by selecting "9" **7042**. If the

user selects "9", the call is terminated **7044**. If the user does not select '9" within a specified period of time, the automated telephone system continues to instruct the user, "To be connected to a DAN Operator, press or say "0", or say on the line" **7046**. The automated telephone system then forwards the user's call, to a live operator for assistance **7048**. The live operator has direct access to all components of the DAN **8100** and can assist the user's how are having trouble with the automated system.

[**0635**] Now referring to **FIG. 71**, the automated telephone system instructs the user, "Please dial or speak the area code and phone number of your desired destination to receive directions to that location" **7100**. The automated telephone system waits for the user to dial or speak the area code and telephone number to the desired destination **7102**. The automated telephone system waits for the user to respond within a specified period of time by dialing the phone number **7104**. If the user dials the phone number, the number is matched against numbers within the PSTN phone location database **7110** of business and residential listings, which may be internal or external to the DAN **8100**. The automated telephone system then tells the user, "We have located "X" number possible match(s)" **7114**.

[**0636**] Still referring to **FIG. 71**, if the user does not dial a phone number within the specified period of time, the automated telephone system waits for the user to respond by speaking the phone number **7106**. If the user does not respond within a specified period of time, the user's query is forwarded to **FIG. 71 BOX 7126**, for further processing. If the user responds by speaking the phone number, a voice recognition program within the DAN **8100** converts the user's words into texts **7108**. The DAN **8100** matches the text against telephone numbers contained within the database of business and residential listings **7112**. The automated telephone system tells the user, "We have located "X" number possible match(s)" **7114**.

[**0637**] Again referring to **FIG. 71**, the automated telephone system then instructs the user, "For directions to "listing 1" located at "address 1" with a phone number of "phone 1", press or say "1" **7116**. The automated telephone system then waits a specified period of time for the user to press or say "1" **7118**. If the user selects "1", the user's choice is logged within the DAN **8100**, and the user's query is forwarded to **FIG. 75, BOX 7500**, for further processing **7120**. If the user

does not select "1", the automated telephone system instructs the user, "To repeat listing(s), press or say "4" 7122. The automated telephone system then waits a specified period of time for the user to respond by pressing or saying "4" 7124. If the user does select "4", the automated telephone system returns to FIG. 71, BOX 7116 and repeats the listing. If the user does not select "4" within the specified period of time, the automated telephone system instructs the user, "To request a new listing, press or say "5" 7126. If the user selects "5", the DAN 8100 returns the user to FIG. 70, BOX 7006, where the user can begin to search for a new listing 7130. If the user does not select "5", the automated telephone system instructs the user, "To be connected to a Directional Assistance Operator, press or say "0", or stay online" 7132. The automated telephone system then forwards the user, to a live directional assistance operator for assistance 7134.

[0638] Now referring to FIG. 72, the automated telephone system instructs the user, "Please speak the name of the business or residents you wish to find" 7200. The automated telephone system waits for the user to speak the name of the desired business or person 7202. The voice interface software 8105 and voice mapping software 8110 within the DAN 8100 converts the user's spoken words into text 7204. The DAN 8100 matches the text against names within the PSTN phone location database 8145, which may be internal or external to the DAN 8100, BOX 7206. The automated telephone system then informs the user, "We have located "X" number of possible match(s)" 7208.

[0639] Still referring to FIG. 72, the automated telephone system then instructs that user, "For directions to "listing 1" located at "address 1", with a phone number of "phone number 1", press or say 1" 7210. The automated telephone system then waits a specified period of time for the user to respond by selecting "1" 7212. If the user selects "1", the user's choice is logged into the DAN 8100, and the DAN 8100 forwards the user to FIG. 75, BOX 7500, for further processing 7214. If the user does not respond by selecting "1", the automated telephone system instructs the user, "For directions to "listing 2" located at "address 2", with a phone number of "phone number 2", press or say "2" 7216. The automated telephone system then waits a specified period of time for the user to respond by selecting "2" 7218. If the user selects "2", the user's choice is logged into the DAN 8100, and the DAN 8100 forwards the user to FIG. 75, BOX 7500, for further processing 7220. If the user does not respond by selecting "2", the automated telephone system

instructs the user, "For directions to "listing 3" located at "address 3", with a phone number of "phone number 3", press or say "3" 7222. The automated telephone system then waits a specified period of time for the user to respond by selecting "3" 7224. If the user selects "3", the user's choice is logged into the DAN 8100, and the DAN 8100 forwards the user to FIG. 75, BOX 7500, for further processing 7226.

[0640] Again referring to FIG. 72, if the user does not respond by selecting "3", the automated telephone system instructs the user, "To repeat the previous listing(s), press or say "4" 7228. The automated telephone system then waits a specified period of time for the user to respond by selecting "4" 7230. If the user selects "4", the DAN 8100 returns the user to FIG. 72, BOX 7210, where listings are repeated by the DAN's automated telephone system. If the user does not select the automated telephone system instructs the user, "To request a new listing, press or say "5" 7232. The automated telephone system then waits a specified period of time for the user to respond by selecting "5" 7234. If the user selects "5", the DAN 8100 returns the user's query to FIG. 70, BOX 7006, where a new query process can begin 7236. If the user does not select "5", the automated telephone system instructs the user, "To be connected to a Directional Assistance Operator, Press "0", or say on the line" 7238. The user's call is then forwarded to a live operator for assistance 7240.

[0641] Now referring to FIG. 73, the automated telephone system instructs the user, "Please speak the category of business you wish to find" 7300. The automated telephone system waits for the user to speak the name of the desired business category 7302. The voice interface software 8105 and voice mapping software 8110 within the DAN 8100 converts the user's spoken words into text 7304. The DAN 8100 matches the text against categories within the PSTN phone location database 8145 that most closely correspond to the user's geographic location 7306. If the DAN 8100 does not find any listings within the user's selected category 7308, the automated telephone system informs the user, "No listings were found in this category" 7336. The automated telephone system then instructs the user, "To request a new listing, press or say "5" 7338. The DAN 8100 then waits a specified period of time for the user's response 7340. If the user selects "5", the user is returned to FIG. 70, BOX 7006, for an opportunity to select a new listing 7342. If the user does not select "5", the automated telephone system instructs the

user, "To be connected to a Directional Assistance Operator, Press "0", or say on the line" **7344**. The user's call is then forwarded to a live operator for assistance **7346**.

**[0642]** Still referring to **FIG. 73**, if the DAN **8100** finds the requested category, the listings contained within that category are sorted according to distance from the user's geographic location **7310**. The automated telephone system then informs the user, "We have located "X" number of possible match(s)" **7312**. The number "found" listings that are actually available to the user can be set within the DAN **8100** so as only to provide, for example, only the three closest listings within the selected category.

**[0643]** Still referring to **FIG. 73**, the automated telephone system then instructs that user, "For directions to "listing 1" located at "address 1", with a phone number of 'phone number 1', press or say "1" **7314**. The automated telephone system then waits a specified period of time for the user to respond **7316**. If the user selects "1", the user's choice is logged into the DAN **8100**, and the DAN **8100** forwards the user to **FIG. 75, BOX 7500**, for further processing **7318**. If the user does not respond, the automated telephone system instructs the user, "For directions to "listing 2" located at "address 2", with a phone number of "phone number 2", press or say "2" **7320**. The automated telephone system then waits a specified period of time for the user to respond **7322**. If the user selects "2", the user's choice is logged into the DAN **8100**, and the DAN **8100** forwards the user to **FIG. 75, BOX 7500**, for further processing **7324**. If the user does not respond, the automated telephone system instructs the user, "For directions to "listing 3" located at "address 3", with a phone number of "phone number 3", press or say "3" **7326**. The automated telephone system then waits a specified period of time for the user to respond **7328**. If the user selects "3", the user's choice is logged into the DAN **8100**, and the DAN **8100** forwards the user to **FIG. 75, BOX 7500**, for further processing **7330**.

**[0644]** Again referring to **FIG. 73**, if the user does not respond, the automated telephone system instructs the user, "To repeat the previous listing(s), press or say "4" **7332**. The automated telephone system then waits a specified period of time for the user to respond **7334**. If the user selects "4", the user is returned to **FIG. 73, BOX 7314**, were listings are repeated through the DAN's automated telephone system. If the user does not select "4", the automated telephone



system instructs the user, "To request a new listing, press or say "5" 7338. If the user selects "5", the user's query is returned to **FIG. 70, BOX 7006**, where a new query process can begin 7342. If the user does not select "5", the automated telephone system instructs the user, "To be connected to a Directional Assistance Operator, Press "0", or say on the line" 7344. The user's call is then forwarded to a live operator for assistance 7346.

[0645] Now referring to **FIG. 74**, the automated telephone system instructs the user, "Please speak the complete Street address including city and state, to receive phone number and directions to that address" 7400. The automated telephone system waits for the user to speak the name of the desired business or person 7402. The voice interface software 8105 and voice mapping software 8110 within the DAN 8100 converts the user's spoken words into text 7404. The DAN 8100 matches the text against addresses within the PSTN phone location database 7406. The automated telephone system then informs the user, "We have located "X" number of possible match(s)" 7408.

[0646] Still referring to **FIG. 74**, the automated telephone system then instructs the user, "For directions to "listing 1" located at "address 1", with a phone number of "phone number 1", press or say 1" 7410. The automated telephone system then waits a specified period of time for the user to respond 7412. If the user selects 1", the user's choice is logged into the DAN 8100, and the DAN 8100 forwards the user to **FIG. 75, BOX 7500**, for further processing 7414. If the user does not respond, the automated telephone system instructs the user, "For directions to "listing 2" located at "address 2", with a phone number of "phone number 2", press or say "2" 7416. The automated telephone system then waits a specified period of time for the user to respond 7418. If the user selects '2" the user's choice is logged into the DAN 8100, and the DAN 8100 forwards the user to **FIG. 75, BOX 7500**, for further processing 7420. If the user does not respond, the automated telephone system instructs the user, "For directions to "listing 3" located at "address 3", with a phone number of "phone number 3", press or say "3" 7422. The automated telephone system then waits a specified period of time for the user to respond 7424. If the user selects "3", the user's choice is logged into the DAN 8100, and the DAN 8100 forwards the user to **FIG. 75, BOX 7500**, for further processing 7426.

[0647] Again referring to **FIG. 74**, if the user does not respond, the automated telephone system instructs the user, "To repeat the previous listing(s), press or say "4" **7428**. The automated telephone system then waits a specified period of time for the user to respond **7430**. If the user selects '4", the DAN **8100** returns the user to **FIG. 74**, BOX **7410**, where listings are repeated. If the user does not select "4", the automated telephone system instructs the user, "To request a new listing, press or say "5" **7432**. If the user selects "5", the user's query is returned to **FIG. 70**, BOX **7006**, where a new query process can begin **7436**. If the user does not select "5", the automated telephone system instructs the user, "To be connected to a Directional Assistance Operator, Press "0", or say on the line" **7438**. The user's call is then forwarded to a live operator for assistance **7440**.

[0648] Now referring to **FIG. 75**, the automated telephone system instructs the user, "To receive directions based on fastest travel time with current traffic conditions, press or say 1" **7500**. The automated telephone system waits a specified period of time for the user to respond **7502**. If the user does not respond with a specified period of time, the query process is forwarded to **FIG. 76**, BOX **7600**, for further processing **7506**. If the user does select "1", the traffic monitoring software **8125** and routing software **8120**, within the DAN **8100**, plots the user's location and location of the selected destination, and determines a selected number of possible logical routes. The routes are sent to the DAN's traffic monitoring software and routing software **7504**. The traffic monitoring software **8125** and routing software **8120** queries the wireless network's ULD **900** to examine the flow of traffic based on the movement and density of wireless devices, and calculates the fastest route based on available information including traffic movement, speed limits (if available) and distance **7508**.

[0649] Still referring to **FIG. 75**, upon determining the fastest route, the traffic monitoring software **8125** and routing software **8120** then calculates direction, distance, and estimated travel time **7510**. The automated telephone system then informs the user, "Your destination is "X' miles "North/South" and "Y" miles "East/West", with an estimated driving distance of "W" miles. Current travel time is estimated at '1' minutes" **7512**. The automated telephone system then instructs the user, "To continue with these directions and receive the travel plans, press or say "1" **7514**. The automated telephone system then waits a specified period of time for the user to select

1" **7516**. If that user does not respond with within a specified period of time, the automated telephone system then instruments the user, "To repeat the previous information, press or say "2" **7528**. The automated telephone system then waits a specified period of time for the user to select '2" **7530**. If the user responds by selecting '2", the DAN **8100** returns the user to **FIG. 75, BOX 7512**. If the user does not select "2" within a specified period of time, the automated telephone system then instruments the user, To return to the main menu, or to enter a new destination, press or say "3" **7532**. The automated telephone system then waits a specified period of time for the user to select "3" **7534**. If the user responds by selecting "3", the user is returned to **FIG. 70, BOX 7006** to began a new query **7536**. If the user does not select "3" within a specified period of time, the automated telephone system then informs the user, "Thanking you for using the Direction Assistance Service", and the call is terminated **7526**.

[**0650**] Again referring to **FIG. 75, BOX 7516**, if the user selects "1", the automated telephone system then instructs the user, "To repeat these directions at anytime, press or say "9". The directions are as follows, "XXXXXX" **7518**. The automated telephone system then instructs the user, "To be instructed when to turn, to receive a notice when the fastest route to changes due to traffic conditions, or to receive a map of the travel plan, press or say 1" **7520**. The automated telephone system then waits a specified period of time for the user to select "1" **7522**. . If the user responds by selecting "1", the user is forwarded to **FIG. 79, BOX 7900** for further processing **7524**. If the user does not select "1" within a specified period of time, the automated telephone system then informs the user, "Thanking you for using the Direction Assistance Services", and the call is terminated **7526**.

[**0651**] Now referring to **FIG. 76**, the automated telephone system instructs the user, "To receive directions based shortest travel distance, press or say "2" **7600**. The automated telephone system waits a specified period of time for the user to respond **7602**. If the user does not respond with a specified period of time, the DAN **8100** forwards the query process to **FIG. 77, BOX 7700**, for further processing **7606**. If the user does select "2", the traffic monitoring software **8125** and routing software **8120** comprised within the DAN **8100**, plots the user's location, and location of the selected destination, and determines the shortest possible logical route **7604**. The traffic monitoring software **8125** and routing software **8120** then determines the direction, distance, and

estimated travel time **7610**. The automated telephone system then informs the user, "Your destination is "X" miles "North/South" and "Y" miles "East/West", with an estimated driving distance of "W" miles. Driving time is estimated at "Z" minutes" **7612**. The automated telephone system then instructs the user, "To continue with these directions and receive the travel plans, press or say "1" **7614**. The automated telephone system then waits a specified period of time for the user to select "1" **7616**. If that user does not respond within a specified period of time, the automated telephone system then instructs the user, "To repeat the previous information, press or say "2" **7628**. The automated telephone system then waits a specified period of time for the user to select "2" **7630**. If the user responds by selecting "2", the user is returned to **FIG. 76, BOX 7612**. If the user does not select "2" within a specified period of time, the automated telephone system then instructs the user, "To return to the main menu, or to enter a new destination, press or say "3" **7632**. The automated telephone system then waits a specified period of time for the user to select "3" **7634**. If the user responds by selecting "3", the DAN **8100** returns the user to **FIG. 70, BOX 7006** to begin a new query **7636**. If the user does not select "3" within a specified period of time, the automated telephone system then informs the user, "Thanking you for using the Directional Assistance Services", and the call is terminated **7626**.

**[0652]** Again referring to **FIG. 76, BOX 7616**, if the user selects "1", the automated telephone system then instructs the user, "To repeat these directions at anytime, press or say "9". The directions are as follows, "XXXXXX" **7618**. The automated telephone system then instructs the user, "To be instructed when to turn, or to receive a map of the travel plan, press or say "1" **7620**. The automated telephone system then waits a specified period of time for the user to select "1" **7622**. If the user responds by selecting "1", the DAN **8100** forwards the user to **FIG. 79, BOX 7900** for further processing **7624**. If the user does not select "1" within a specified period of time, the automated telephone system then informs the user, "Thanking you for using the Directional Assistance Services", and the call is terminated **7626**.

**[0653]** Now referring to **FIG. 77**, the automated telephone system instructs the user, "To be connected to your selective listing, press or say "3" **7700**. The automated telephone system waits a specified period of time for the user to respond **7702**. If the user does select "3", the automated telephone system connects the user to their selected listing **7704**. If the user does not respond by

selecting "3" within a specified period of time, the automated telephone system instructs to user, "To repeat these choices, press or say "4" 7706. If the user does select '4", the automated telephone system returns the user to **FIG. 75, BOX 7500**, and the query process continues 7710. If the user does not respond by selecting "4" within a specified period of time, the automated telephone system instructs to user, "To return to the main menu or to enter a new destination, press or say "5" 7712. If the user does select "5", the automated telephone system returns the user to **FIG. 70, BOX 7006**, and the query process starts over 7716. If the user does not respond by selecting "5" within a specified period of time, the automated telephone system returns the user to **FIG. 70, BOX 7046** and the user is connected to a live Directional Assistance Operator 7718.

[0654] Now referring to **FIG. 78**, the automated telephone system instructs the user, "Please dial the area code and phone number of the wireless communications device you want to locate 7800. The automated telephone system then waits a specified period for time for the user to respond by dialing the wireless communications device's phone number the user wishes to find 7802. If the user does not respond within the specified period of time, the automated telephone system instructs the user, "To request a new listing, press or say 4" 7832. If the user does respond within the specified period of time, the telephone phone number is logged into the DAN 8100 and the telephone number is matched against telephone numbers within the wireless communication network's ULD 900, BOX 7804. The DAN 8100 then determines if the requested telephone number is located 7806.

[0655] Still referring to **FIG. 78, BOX 7806**, if the phone number is not found, the automated telephone system instructs the user, "The wireless communications device (WCD) you are trying to locate cannot be found at this time. Please record and message for the wireless communications device's user, or press "4" for more options." If the user selects "4", the query is forwarded to **FIG. 78, BOX 7832**, to begin a new query 7808. If the user does not selected "4", the DAN's voice mail system records the caller's message. The DAN 8100 searches for the wireless communications device periodically. When the wireless communications device is located, the DAN 8100 calls the wireless communications device and plays the recorded message 7810.

[0656] Again referring to **FIG. 78**, **BOX 7806**, if the phone number is found, the automated telephone system tells the user, "We have located the phone number "XXX-XXX-XXXX" **7812**. The automated telephone system then tells the user, "For current location of the wireless communications device, press or say "1" **7814**. The automated telephone system then waits a specified period of time, for the user to respond by pressing 1" **7816**. If the user does not select "1", the automated telephone system forwards the user to **FIG. 78**, **BOX 7832**, to request a new listing. If the user does select "1", the DAN's geographic database mapping software **8155** criss-cross lat/long geographic database **8150** and then converts the longitude and latitude coordinates provided by the wireless communication network's ULD **900** to a street address format **7818**. The automated telephone system then informs the user of the Street address by saying, "The wireless device is currently located at "XXXXXXXX" **7820**. The automated telephone system then instructs the user, "To repeat this location, press or say "2" **7822**. The automated telephone system then waits for the user to respond by selecting "2" **7824**. If the user does select "2" within a specified period of time, the users query is returned to **FIG. 78**, **BOX 7820**, in order to repeat the location information.

[0657] Still referring to **FIG. 78**, **BOX 7824**, if the user does not select "2" within the specified period of time, the automated telephone system then instructs the user, "To receive a map of the wireless device's location, or to track the wireless device, press or say "3" **7826**. The automated telephone system then waits for the user to respond within a selected period of time by selecting "3" **7828**. If that user does select "3" within the specified period of time, the DAN 8100 logs the user's choice and forwards the user's query to **FIG. 79**, **BOX 7900**, for further processing **7830**. Again referring to **FIG. 78**, **BOX 7828**, if the user does not select "3" within the specified period of time, the automated telephone system instructs the user, "To request a new listing, press or say "4" **7832**. The automated telephone system then waits for the user to respond by selecting "4" **7834**. If the user selects "4" within the specified period of time, the user's query is forwarded to **FIG. 70** **BOX 7006** to begin a new query **7836**. If that user does not select "4" within the specified period of time, the automated telephone system instructs the user, "To be connected to the Directional Assistance Operator, press "0" or stay on the line" **7838**. The user is then forwarded to a live Operator for assistance **7840**.

[0658] Now referring to **FIG. 79**, the automated telephone system instructs the user, "To have a map and travel plans sent to your wireless device via a page, press or say "1" **7900**. The automated telephone system then waits for the user to respond by selecting "1" **7902**. If the user selects "1", the DAN **8100** sends a map and travel plans to the standardization/conversion hardware/software **8160** to convert the map and travel plan to a format which will interface with the protocol of the user's wireless device. The map and travel plans are sent to the user's wireless device via a page and are updated if the user requests an update as traffic conditions change to as to offer a faster route. The user can also be notified when to turn if the DAN **8100** monitors the user's location and pages the user when the user is approaching a turn **7904**.

[0659] Again referring to **FIG. 79**, **BOX 7902**, if the user does not select '1', the automated telephone system instructs the user, "To have a map and travel plans sent to your e-mail address, press or say '2" **7906**. The automated telephone system then waits for the user to respond by selecting "2" **7908**. If the user selects "2", the DAN **8100** instructs the user to enter their e-mail address via keypad/keyboard, voice recognition, interactive display screen or other. The DAN **8100** then sends a map and travel plans to the standardization/conversion hardware/software **8160** to convert the map and travel plan to a format which will interface with the protocol of the user's e-mail service and navigational program. The map and travel plans are sent to the user's e-mail address and are updated if the user requests an update as traffic conditions change to as to offer a faster route. The user can also be notified when to turn if the DAN **8100** monitors the user's location and e-mails the user when the user is approaching a turn **7910**.

[0660] Again referring to **FIG. 79**, **BOX 7908**, if the user does not select "2", the automated telephone system instructs the user, "To have a map and travel plans sent to your fax machine, press or say '3" **7912**. The automated telephone system then waits for the user to respond by selecting "3" **7914**. If the user selects "3", the DAN **8100** instructs the user to enter the area code and telephone number where the faxes are to be sent. The DAN **8100** then sends a map and travel plans to the standardization/conversion hardware/software **8160** to convert the map and travel plan to a format, which will interface with the protocol of the user's Fax machine/program. The map and travel plans are sent to the user's fax machine and are updated if the user requests an update as traffic conditions change to as to offer a faster route. The user can also be notified

when to turn if the DAN **8100** monitors the user's location and fax the user when the user is approaching a turn **7816**.

[0661] Again referring to **FIG. 79**, **BOX 7914**, if the user does not select "3", the automated telephone system instructs the user, 'To track a wireless device and have a map of their location sent to your wireless device, e-mail or fax, press or say "4" **7918**. The automated telephone system then waits for the user to respond by selecting "4" **7920**. If the user selects "4", the DAN **8100** instructs the user to enter whether the tracking and map information should be sent to their wireless communication device, e-mail, website, navigational system, computer or fax. The users choice can be entered via a keyboard/keypad, voice recognition, interactive display screen or other. The DAN **8100** then instructs the user to input the wireless device area code and phone number, e-mail address, website address, navigational system address, computer address and/or area code and telephone number were the map and location information is to be sent regarding the wireless device being monitored. The DAN **8100** then sends a map and travel plans to the standardization/conversion hardware/software to convert the map and travel plan to a format, which will interface with the protocol of the user's wireless device, e-mail, website, navigational system, computer system or Fax machine/program. The map and location information are sent to the user's wireless device, e-mail, website, navigational system, computer system or fax machine and are updated if the user requests an update, as monitored wireless device travels from one location to another, or from time to time **7922**.

[0662] Again referring to **FIG. 79**, **BOX 7920**, if the user does not select "4", the automated telephone system instructs the user, "To repeat these choices, press or say "5" **7924**. The automated telephone system then waits for the user to respond by selecting "5" **7926**. If the user selects "5", the users query is returned to **FIG. 79**, **BOX 7900**, to repeat the choices **7928**.

[0663] Again referring to **FIG. 79**, **BOX 7926**, if the user does not select "5", the automated telephone system instructs the user, "To return to the main menu, press or say "6" **7930**. The automated telephone system then waits for the user to respond by selecting "6" **7932**. if the user selects "6", the users query is returned to **FIG. 70**, **BOX 7006**, to restart the query process **7934**. If the user does not select "6", the automated telephone system returns the user to **FIG. 70**, **BOX**



7046, to be connected with a Directional Assistance Operator 7936.

[0664] FIG. 80 is a flowchart describing the operation of the DAN's traffic monitoring software 8125 and routing software 8120. To begin the query process, the traffic monitoring software 8125 and routing software 8120 plots the user's location. If the user is calling from a wireless device, the DAN 8100 queries the wireless network's ULD 900 to retrieve the user's longitude and latitude coordinates. The DAN 8100 then converts the longitude and latitude coordinates to a street address or location. This location is plotted into the traffic monitoring software 8125 and routing software 8120. If the user is calling from a landline within a PSTN 8138, the DAN 8100 retrieves the users location from the PSTN phone location database 8145. Then the DAN 8100 plots the street address provided by the PSTN phone location database into the traffic monitoring software 8125 and routing software 8120 BOX 8000.

[0665] Still referring to FIG. 80, the DAN 8100 then plots the user's desired destination by cross-referencing and retrieving the destination information from the PSTN phone location database 8145. If the user has entered more than one destination, the DAN 8100 can plot multiple destinations for route planning purposes 8002. The traffic monitoring software 8125 and routing software 8120 then determines a selected number of possible logical driving routes and the distance in miles or meters for each possible route 8004. The traffic monitoring software 8125 and routing software 8120 then examines the movement of wireless devices that are traveling the possible logical routes to determine average speed or number of wireless devices on the possible logical routes 8006. The traffic monitoring software 8125 and routing software 8120 then calculates the estimated travel time for each route in order to determine the shortest possible travel time. Routes are considered in order of miles/meters from shortest to longest. The basic formula to obtain the travel time for a possible route is as follows:

Distance (miles/meters) X Average Speed (Miles/Meters Per Hour) = Route Travel Time

[0666] This is the basic formula, but other formulas may be entered into the traffic monitoring software 8125 and routing software 8120 to include such things as number of wireless devices on a route, weather conditions, posted speed limits, train schedules, road work, road closures,

historical average speeds based on time of day/year, etc. **8008**. The traffic monitoring software **8125** and routing software **8120** informs the user of the shortest or fastest route (as per their request) and sends the travel plan and map to the user if requested, in the form the user requested (Page to wireless device, e-mail, fax, etc.). If the user has requested to receive updates, the traffic monitoring software **8125** and routing software **8120** monitors the users location and informs them of faster routes, when to turn, and other requested items **8010**.

#### **Detailed Description of the Preferred Embodiment**

[0667] The directional assistance network (DAN) **8100** is a machine and process that provides a dynamic location routing system and directional assistance to an entity through a variety of remote methods. One objective of the DAN **8100** is to provide a means for an entity to request mapping, voice, or other methods of directions that would give the said entity directions from entity's current geographic location to entity's target location. The routing system allows a plurality of devices to connect to the DAN **8100** and request directional assistance to a plurality of target locations.

[0668] The claimed entities could exist as a:

- Wireless device user
- Land line phone user
- Internet (world-wide-web) user
- Intranet user
- Non-human element such a software package
- Voice-over IP network user
- Dial-up user
- Other user selected entities

[0669] The geographic location based technology would allow the said users to be routed along a path that would take the most direct or most timely route to the user's selected destination. For example, a user of a wireless device could query the DAN **8100** for a display of the user's current location on a street map, and the fastest driving route to the user's place of employment, based on current traffic conditions, distance, and other user defined attributes from available sources. The

routing software **8120** within the DAN **8100** facilitates this process. The routing software **8120** allows a discrete computational analysis of traffic conditions based on recorded data from a plurality of sources. Current day realizable sources of this information are: data sampling from a wireless network, live national traffic alert databases, local traffic database entries, traffic cams, traffic radar gun" database, direct user input, or other available sources.

[0670] The DAN **8100** also comprises traffic monitoring software **8125** that monitors traffic conditions in real time by, for example, tracking the movement of a plurality of wireless devices to determine the location of slow moving traffic. The routing software **8120** uses the traffic monitoring software **8125** to determine routing information, in order to provide directional assistance. This directional assistance is deliverable to the above listed entities.

[0671] The user can select routing information based on the following:

- Time to destination
- Distance to destination
- Alternate routes based on 'way points' set by user
- Scenic routes (pre-programmed scenic information comprised within a criss-cross lat/long geographic database **8150**)
- Routes bases on probability of reaching a destination within time constraints
- Routes to alternate locations of similar interest (Hospitals, etc)
- Routes based on user preferences established in a local preferences database.

[0672] The first step of the routing software's **8120** is to retrieve the current geographic location of the requesting entity. The DAN **8100** retrieves the users current geographic location using the device location software **8115**. The device location software **8115** allows the location of a wireless device, (and-fixed, Internet, or other user defined entity to be obtained. The device location software **8115** has the ability to query external sources for information. In the case of a wireless network, the device location software **8115** would analyze wireless network parameters and data at the base station controller (BSC) **206** or the MTX **130** for call information to determine the location of a wireless device.

[0673] An additional technology that would allow rapid access to this data would be a dynamic database or system designed to store and hold information including latitude and longitude of the said wireless devices.

[0674] The supporting databases required for the above claimed software to function include a criss-cross lat/long geographic database **8150**. The crisscross at/long geographic database **8150** contains latitude and longitude information correlating to actual street locators, such as a directory of listings of business and residential address locations and contact information. Scenic locations, hospitals, and other 'categorized' locations could be extrapolated from this database.

[0675] The geographic database mapping software **8155** controls the criss-cross lat/long geographic database **8150**. The geographic mapping software **8155** allows multiple simultaneous requests, and is responsible for both resolving addressing information to latitude/longitude coordinates and resolving latitude/longitude coordinates to addressing information. To effective processing, the external connections to the criss-cross lat/long geographic database **8150**, and primary logic software **8101**, can utilize an ATM type packet routing. The ATM type pocket routing will allow very fast switching times and transfer speeds.

[0676] To allow the entities to access the claimed primary embodiment, the DAN **8100** contains two similar software packages. The first software package is the voice interface software **8105**. The voice interface software **8105** allows the user to access the functionality of the DAN **8100** via the human voice, To interpret the voice signal of the user, the voice interface software **8105** works with the voice mapping software **8110**. The voice mapping software **8110** interprets voice signals from the user (spoken words) and converts the voice signals into data inputs for the voice interface software **8105**.

[0677] The voice mapping software **8110** allows the user to walk through a series of menus and input information. Menus such as "press 1 to spell or say the name of your destination" will be synthesized and presented to the human user. The user can then respond using their voice, "Hospital". The voice mapping software **8110** would then resolve the spoken work "Hospital" into a data representation of the term. In addition, the voice mapping software **8110** allows target

location information to be resolved into a data-formatted address that can be used along with the routing software to route directions, The next software component utilized by the DAN **8100** is the data interface software **8130**. The data interface software **8130** receives input data in a usable format. The data interface software **8130** simply parses the supplied data and passes it to the DAN's **8100** primary logic software **8101**.

[0678] The external DAN query interface software **8135** allows external connectivity to the DAN **8100**. The external DAN query interface software **8135** adapts and standardizes the many different physical interfaces and protocols that connects with the DAN **8100**. The package is very important because it needs to be able to support many sophisticated entities that connects to the DAN **8100**. The entities supply data in many different ways. These external connections to query devices **8140** can be:

- Physical
  - o Data connections (Ti, DCI, etc)
  - o Telephony connections
  - o Wireless network connection
  - o Direct Dial-up connection
- Data Formats
  - o SQL database entries
  - o Scripting
  - o Unformatted raw ascii text
  - o Formatted text
  - o WAP text entries
- Data Interface Protocols
  - o ftp
  - o http
  - o telnet
  - o dial-up
  - o direct-connect

## SMS

[0679] The external DAN query interface software **8135** takes these external sources and formats the data stream that both the data interface software **8130** and the voice mapping software **8110** use to retrieve information from external sources.

[0680] The DAN **8100** also includes the standardization/conversion hardware/software **8160**. The standardization/conversion hardware/software **8160** is listed under the previously referenced provisional patent. The standardization/conversion hardware/software **8160** functions under a singleinput/single-output (SISO) type control structure, where a single input results in a single output. The standardization/conversion hardware/software **8160** receives a command from one protocol, and outputs the correct protocol to the receiving machine.

[0681] The standardization/conversion hardware/software **8160** receives a command from an external network connection **8165** or from the primary logic software **8101**. The standardization/conversion hardware/software **8160** first checks the received protocol against a pre-configured protocol, and then checks known types of protocols by querying an internal protocol database. If there is a matching protocol found within the internal protocol database, then the standardization/conversion hardware/software **8160** the appropriate protocol by checking the receive protocol list. The standardization/conversion hardware/software **8160** then determines if a conversion can be made. If the standardization/conversion hardware/software **8160** can convert the protocol command, then the command is sent to the connected device. The standardization/conversion hardware/software **8160** waits for another command. If any of the decision boxes are "no" than an error is recorded and send back to the sending source.

[0682] The standardization/conversion hardware/software **8160** differs from the external DAN query interface software **8135** in that the DAN **8100** utilizes the standardization/conversion hardware/software **8160** to connect to networks or other devices and retrieve information used by various subroutines. The general example would be for the DAN **8100** to query a wireless network's MTX **130** and then BSC **206** to retrieve user information.

[0683] Controlling all the software and hardware of the DAN **8101** is the primary logic software **8101**. The primary logic software **8101** generates and processes the usage and pure control commands. Data storage is also part of the primary logic software **8101**. The primary logic software **8101** must be able to process a large volume of external requests and processes created by entities requesting geographic routing information.

[0684] The recommended physical architecture that the DAN **8100** would reside in a hardware that could supply enough bandwidth, memory, physical storage and processing ability to respond to an entities geographic routing request in a reasonable amount of time determined by a customer.

[0685] The location that the DAN **8100** could exist can be any of the following:

- At a wireless switching office
- At telephony switching center/PSTN
- Located on the internet (with some static/dynamic range of IP addresses)

[0686] In alternate embodiments where the DAN **8100** is located at locations other than a wireless network, additional equipment will need to be located at a wireless switch. The DAN linking software **8300** allows remote queries of the wireless switch. The DAN linking software **8300** connects to the e-mobility services **144** that links to the MTX **130**. The DAN linking software **8300** includes the interim linking software **8515**. The interim linking software **8515** negotiates and retrieves data from the MTX **130** or the BSC **206** components of a wireless switch. In addition, the DAN linking software **8300** includes packet routing software/hardware **8520** that allows packets to be passed from wireless devices (the WAP/e-mobility connections) to the DAN **8100** that is remotely located. The DAN linking software **8300** also includes the DAN data query software **8525** to manage the methods used to query the local wireless networks hardware/software.

**[0687] Routing Methodology to obtain directions for requesting entity**

When an entity connected to the DAN **8100** requests directions to an address or location, the DAN **8100** must have access to data sources that gives the location of the wireless device and the target location.

**[0688]** The following are examples of data sources for obtaining this information:

- User location database (ULD) - containing mobile device location information **900**
- User location database coordinator (ULDC) - Containing ability to query multiple ULD's **908**
- Direct query of MTX **130** or BSC **206** for location of wireless devices Location information calculated by GPS at/in the wireless device
- Public addressing database containing addressing for location queried by wireless device.
- PSTN Database with a correlated lat/long information for a fixed device, **8145**
- Location information sent from the querying device to the DAN **8100**

When a wireless device requests directions to a location the following steps to carry out this process:

- The DAN determines the wireless devices current location in terms of latitude/longitude and converting to postal addressing relative to roadways.
- The DAN then determines the location of the target
- The DAN then calculates the route to the target through current streets and roads

**[0689]** The DAN **8100** determines the wireless devices' location with the use of the criss-cross lat/long geographic database **8150**, latitude/longitude coordinates obtained by GPS systems on the wireless device, a location retrieved through a ULD **900** or ULDC **908**, or similar device that calculates the current location.

**[0690]** The criss-cross lat/long geographic database **8150** can convert either an address to a latitude/longitude coordinate or a latitude/longitude coordinate into an address. After obtaining the location of the device in latitude/longitude coordinate form the information is processed and converted to standard addressing.



[0691] Next, the DAN **8100** determines the target's location. The target location address could be resolved by querying a public addressing database for known locations. If the target location is another wireless device, the location would be retrieved through a ULD **900**, or ULDC **908**, or by querying the MTX **130** and/or the BSC **206** controlling the target wireless device, then converted to a standard address by the criss-cross lat/long geographic database **8150**.

[0692] Next, the DAN **8100** determines the most efficient route to the target address. While current commonly known software can accomplish this task, it is limited to resolving routes based on:

- Shortest distance (miles/Kilometers) traveled
- Time to arrive at destination
- User sensitive settings such as scenic routes

[0693] What the commonly used software lacks is the ability to compensate for current road conditions (traffic jams, weather, etc). The DAN **8100** has the ability to resolve routes using information obtained from a wireless network or from other traffic databases, to determine the fastest route in units of time or distance. The routing software **8125** initially determines the route using commonly known methods, but then uses a unique and new method to check the level of traffic congestion along the route.

[0694] The level of traffic congestion can be determined from either gathering information from traffic databases or from obtaining the location of devices on a wireless network. To gather the location of devices on any given segment of a road or route, data can be gathered from a MTX **130**, in combination with a ULD **900** or ULDC **908**, or direct query of the MTX **130** or the BSC **206**.

The information obtained from the ULD/ULDC/Direct Query includes the following:

- Number of wireless devices on the route calculated to target location
- Location of wireless devices on the route calculated to target location
- Current state (active/standby) of wireless devices along calculated route

[0695] The routing software **8120** uses the route wireless device information to determine the congestion of the route. The congestion is measured by the following calculations. First, the location of the wireless devices is correlated to locations on the route. Next, the velocities of the wireless devices are calculated. The velocity is calculated by sampling the location of a device at fixed time intervals. The routing software **8120** then compares the velocities of the devices to the posted speed limits along the different segments of the route. The comparison measures the traffic flow and validates the devices that are in the traffic route and not on a sidewalk or other close area.

[0696] In addition, the routing software **8120** calculates the wireless device geographic density along the route. Average and normal density would be calibrated depending on the size and attributes of the road. For example, a larger road would have a different average density than a smaller road. A multilane highway would have a different average density than a two-lane highway. The average values for wireless device density on roads would have to be adjusted for various road attributes. The routing software **8120** evaluates the current levels and compares them to the average value.

[0697] After the routing software **8120** calculates the traffic density measurement, the routing software **8120** evaluates the traffic conditions along any given route. The routing software **8120** compares the calculated traffic density to a predetermined normal level.

[0698] The comparison is described by the following:

$D_r = D_c/D_n$ , where  $D_r$  = density ratio,  $D_c$  = current density, and  $D_n$  = normal density.

[0699] Using this formula, the density ratio for any traffic condition is calculated. For example, if a current traffic density of a geographic region is **100** units/distance, and the normal density is 50 units/distance, then the density ratio would be 2. The density ratio corresponds to 2 times or 200% more traffic than the normal traffic density for that area.

[0700] The equation that determines the time it would take to cross a geographic segment is defined by the following formula:  $\text{Time} = \alpha \times e^{D_r \cdot \beta}$  where  $\alpha$  is an experimentally determined

scaling factor that a network engineer can tune, and  $\beta$  is the normal time to cross the geographic segment. From this formula it is apparent that when  $\beta$  is adjusted the time can be linearly scaled by the traffic engineer. It is also apparent that when the value of  $D$  changes that the Time changes exponentially. This should make since  $b/c$  as traffic increases, the time does not increase linearly

[0701] For example, when  $D_r$  is 2 (2 times more or 200% the normal traffic) the time to reach the destination is not double the time, but less than that amount of time. Using the formula you can see the affects of the values of  $D_r$  and in **FIG. 86** and **87** respectively.

[0702] After the time calculation is computed an adjusted travel time for the segment is sent to the routing software. Alternate routes based on normal traffic travel times are then send and run through this algorithm. When the route with least time based on actual traffic conditions is found, the DAN **8100** locks the route as the best traffic route. Each segment of the route is completed in this method. The result is a complete route from the origin of the device to the destination that allows for the quickest travel based on time.

[0703] The DAN **8100** then sends the resulting route to the wireless device and the wireless device displays the route to the user. The user can then travel to the location. If the user desires, the software can continually monitor the route and alert the user to changing road conditions and report route corrections to the previous calculated directions. The user can then take additional detours to further speed the time or distance to the route.

[0704] If the user requests directions to a wireless device on the wireless network, the calculated route would obviously not be a static route. The DAN **8100** would continuously update the route as required. The route could be calculated based on the route taken by the wireless device being tracked, or by simply using the method above to determining the fastest route to the target. The current state of the tracked wireless device would be taken into account. If the tracked wireless device were in an active state, then the route would update continuously. However, if the tracked wireless device is not active or if current location information is not available, then the route would not update, and the DAN **8100** can calculate the route using the last known

location of the wireless device. The DAN **8100** would relay the tracked wireless device state to the requesting wireless device.

**ALTERNATE EMBODIMENT TO THE DIRECTIONAL ASSISTANCE NETWORK**

**[0705]** The primary embodiment refers to a system that users on a plurality of devices (wireless/fixed location) may obtain directional mapping from their current locations. The DAN **8100** can also be implemented by an alternate method. The alternate method would include directional mapping databases and software integrated into its system. The method would not take into consideration traffic density and other variables that would affect directional routing.

**[0706]** For the alternative method to work the wireless device would need to contain a map and a latitude/longitude referenced database of target locations. The databases could be cities, metropolitan areas, states, countries, or other variable sized geographic areas. The map would need to contain information on the current location of the wireless device. The wireless device could obtain the current location information from the device itself using GPS or from the wireless network.

**[0707]** The database would need a large storage medium that could be created on a plurality of mediums including but not limited to:

- Hard Disk
- Micro Drive
- Optical Storage Medium (CD/DVD/etc)
- Flash Memory Device
- Memory Card
- EPROM
- EEPROM
- Removable Storage Medium

**[0708]** The alternate embodiment requires the wireless device to have the ability to locate a destination based on address, company name, landmark, etc. If the wireless device cannot find the destination in the internal database, the wireless device queries the wireless network for the

destination information. The wireless network server resolves the request. When the network server finds the destination information, it sends back the latitude and longitude of the destination to the requesting wireless device. The wireless device stores and appends the destination information with the latitude/longitude in the local database for subsequent path resolution. If the wireless network server does not find the destination, then the wireless device alerts the user that the device could not find the destination.

**[0709]** Advantages of the alternative embodiment are the user will be able to:

- Obtain faster routing information
- Not inquire a connection cost
- Not require an active connection to the network

**[0710]** To allow faster routing, the wireless device can query the wireless network server for traffic congestion information. To allow faster routing of the wireless device in regards to time to the destination or for multiple waypoints and then a destination, a query to the server could be requested if a network connection is available. This would allow the network to access traffic databases that contain information on traffic congestion along a route to be analyzed. Each segment of a route could be analyzed and assigned a numerical figure representing the expected amount of time to travel through the segment. The routing at the server could then send corrections to the device and make alterations to the routing information to improve the results given to the user.

**[0711]** The connection to the network by a device would require any, but not limited to, the following connections that could be resolved and eventually routed to TCP/IP or other I routing protocols:

- TCP/IP Network Connection
- IPX/ULD
- PPP/SLIP
- Wireless Networks
  - o 2G
  - o 3G

- 2.5G
  - GSM
  - TDMA
  - CDMA
  - CDMA2000
- Direct Connection

[0712] To make the computations the wireless network the following are required: a database of a plurality of geographic locations with addressing correlated to latitude and longitudes; software to determine the time to travel on a given route; logistic software to determine a faster route; interface with the requesting software.

[0713] The logistics software works by accessing traffic condition databases not claimed by this patent. The basic requirement of the databases is to return information that corresponds to the traffic density of a roadway or other geographic location. When the logistics software acquires this information, the software compares the current traffic density to a predetermined normal level.

[0714] The resulting route can then (after being calculated) be sent to the wireless device or may already exist there and will not need to be updated in this case. The route will then be graphically reproduced or printed as text and displayed to the user. The user can then travel to the location.

### **Description of Figures**

#### **[0715] FIG. 81**

**FIG. 81** describes the structure of the DAN **8100**. The figure shows the DAN **8100** with all the components logically connected. In addition, the figure illustrates the connectivity of the DAN **8100** to external sources. The figure also illustrates other devices internal to the DAN **8100**.

[0716] The DAN **8100** contains two external connectivity points. The tandardization/conversion hardware/software **8160** connects to an external network connection **8165** and connects the DAN **8100** to friendly networks used to obtain additional data. The external directional assistance

network query interface software **8135** connects to external connections to query devices **8140**. The connection point connects to devices/entities that can remotely query the DAN **8100**. Both the standardization/conversion hardware/software **8160** and the external DAN network query interface software **8140** interface with the primary logic software **8101**.

[0717] The primary logic software **8101** handles the primary control and processing for the DAN **8100**. The primary logic software **8101** controls the interaction between the different internal components and external interfaces, and processes all requests by the different components.

[0718] The data interface software **8130** and voice interface software **8105** allow interactivity to external entities accessing the DAN **8100**. Both components interface with the primary logic software **8101**. The voice interface software **8105** utilizes the voice mapping software **8110**. The voice mapping software also interfaces with the primary logic center **8101**.

[0719] The routing software **8120** component interfaces directly with the primary logic software **8101**. The routing software **8120** utilizes the traffic monitoring software **8125**. The routing software **8120** utilizes the device location software **8115** indirectly. The device location software **8115** interfaces with the primary logic software **8101**. Any access of the device location software **8115** must be done through the primary logic software **8101**.

[0720] The database attached to the DAN **8100** is the criss-cross lat/long geographic database **8150**. The geographic database mapping software **8155** controls and interfaces with the criss-cross at/long geographic database **8150**. Both of these components interface with the primary logic software **8101**. The primary logic software **8101** also interfaces with the PSTN phone location database **8145**.

[0721] **FIG. 82**

**FIG. 82** illustrates the primary embodiment of the invention; the DAN **8100** co-located at a wireless network. **FIG. 82** displays devices that interact with the DAN **8100**. Wireless communication device **8205** connects to cellular towers **8235**, Via Ti/other connection links **8232** from the BTS **108**, the wireless communication device **8205** connects with the cellular base

station controller (BSC) **206**. The BSC **206** links **8227** to the MTX **130**. The MTX **130** links to the e-mobility services **144**. The e-mobility services **144** links to the DAN **8100**. The user location database (ULD) **900** and the wireless communications device location software **8270** also connect to the MTX **130**.

[**0722**] The MTX **130** links to the packet data network (PDN) **156**, and to an internet gateway, **8255** and finally to the Internet **8260**. The MTX **130** also links to a publicly switched telephony network (PSTN) **138**. The PSTN **138** contains the PSTN phone location database **8145**. The PSTN **138** connects to fixed location phones **8220** via land lines **142**.

[**0723**] **FIG. 83**

**FIG. 83** illustrates the primary embodiment's alternate location; the DAN **8100** located remotely via the Internet **8260** at a remote server. **FIG. 83** displays devices that ultimately interact with the DAN **8100**. Wireless communication devices **8205** connect to cellular towers (BTS) **108**. Via Ti/other connection link **8232** from the BTS **108**, the wireless communication devices connect with the base station controller (BSC) **206**. The BSC **206** links **8227** to the MTX **130**. The MTX **130** links to the packet data network (PDN) **156** that links to the internet gateway **8255**. The internet gateway **8225** links to the Internet **8260**. The DAN **8100** interfaces **8310** the wireless network through the Internet **8200**. The ULD **900** and the wireless communications device location software **8270** also connects to the MTX **130**.

[**0724**] The MTX **130** links to the e-mobility services **144**. The e-mobility services **144** links to the DAN linking software, **8300**. The MTX **130** also links to a publicly switched telephony network (PSTN) **138**. The PSTN **138** contains the PSTN phone location database **8145**. The PSTN connects to fixed location phones **8220** via land lines **142**.

[**0725**] **FIG. 84**

**FIG. 84** illustrates the DAN **8100** remotely located at the PSTN **215**. **FIG. 84** displays devices that ultimately interact with the DAN **8100**. Wireless communication devices **8205** connect to cellular towers (BTS) **108**. Via Ti/other connection link **8232** from the BTS **108**, the wireless communication devices **8205** connect with the wireless base station controller (BSC) **206**. The



BSC 206 links 8227 to the MIX 130. The MTX 130 connects to the PSTN 138 and then to the DAN 8100. The PSTN connects to other remote PSTN switching centers also. The PSTN 138 contains the PSTN Phone Location Database 8145. The PSTN 138 connects to fixed location phones 8220 via land lines 142.

[0726] The MIX 130 links to the e-mobility services 144. The e-mobility services 144 links to the DAN linking software 8300. The user location database (ULD) 900 and the wireless communications device location software 8270 also connect to the MIX 130.

**[0727] FIG. 85**

**FIG. 85** illustrates the DAN linking software 8300 used by the DAN 8100. The DAN linking software, 8300, allows the DAN 8100 to interface with wireless networks, when it is remotely located. Wireless communications devices 8205 send requests to the DAN 8100 signals via e-mobility services, 144. The interim linking software 8515 receives the signals and routes them to the packet rerouting software/hardware 8520. Packets are then routed to the remotely located DAN 8100. The DAN data query software 8525 connects to the interim linking software 8515. The DAN data query software 8525 allows the DAN 8100 to remotely pass queries to the MTX, 130, which via the e-mobility services 144.

**[0728] FIG. 86**

**FIG. 86** shows the Traffic Time Calculation Performance Based on user or network-defined variables. The figure shows the alpha, an experimentally obtained scaling factor, on the traffic density-time algorithm. The network engineer determines the value of the variables. As shown, the effects of alpha are linearly proportional to the output of the algorithm. So an increase in one variable proportionally affects the output of the equation.

**[0729] FIG. 87**

**FIG. 87** shows the traffic time calculation performance based on a variable traffic density ratio. The effects of  $D_r$ , the density ratio is shown to produce an exponential result for the expected time to travel on any given route. When the traffic density compared to the normal density level increases, as expected the time to travel along that route increases exponentially as well.

## **PRO-ACTIVE TRAFFIC ROUTING SYSTEM**

### Overview

**[0730]** The traffic control system allows network traffic engineers to optimize traffic flow in real-time based on feedback from systems such as the DAN and the LTS. Both of these system poll on data from other resources such as the ULD/ULDC and GPS data from mobile devices. The location tracking system allows network software located (physically or virtually) at the MTX to access information on the movement of mobile devices on a cellular network.

**[0731]** These moving devices, tracked by the LTS, can be filtered to include only devices on roadways, which is of interest and is used by programs such as the DAN to route users from one location to the next allowing them to avoid traffic congestion. This congestion is based on mobile unit density on the roadways.

**[0732]** Of interest to the traffic control software is the density of traffic along roadway section that have various traffic control devices that can be altered remotely. Altering their parameters would allow traffic flow to be altered and ease congestion. Automating this process, the traffic control software would, in real time, allow traffic congestion reduction over many roadways that otherwise would take much longer to implement. These changes are based on various methodologies described in the following text. Additionally, basic software architecture for such a system is recommended, but does not limit the spirit of this invention.

### **[0733] Traffic Control Devices**

To discuss the ability to monitor or control traffic flow, the devices that control this factor should be discussed. Not all devices that control traffic flow can be remotely controlled, and thus cannot be used by the traffic control software. The devices that can work in this system will be listed and discussed in broad terms, as to allow them to apply to many design n a generic sense. Particular devices may be extruded from these descriptions and easily adapted to any specific setup.

**[0734]** The following generic devices are usable for the traffic control system:

- Intersection Traffic Control Lights
- Highway Inlet Traffic Control Lights
- Variable Speed Limit Roadway Signs

**[0735]** Intersection traffic control lights are defined as those lighting systems that include roadway intersection of two or more roadways at a single point, with a lighting system that directs what road way should cross at any given time. Variables that are affected here are the length any roadway may go cross the intersection, and the length of a turn lane being able to direct traffic from one lane to the next during that cycle.

**[0736]** Highway inlet traffic control lights are a simple way to moderate and control the inlet of traffic onto major roadways. These roadways are typically one directional and the inlet is also one directional. The lighting system is usually an on/off system. A red light moderates traffic by allowing one car though at a time, and then stopping the next car for a time limit, then allowing it to pass and enter the highway. The control variable is the hold time between letting cars though.

**[0737]** Variable speed limit roadways signs are signs that can alter posted speed limits based on a remote signal. The speed limit can be controlled remotely thus allowing the posted limit to change and thus control the flow of traffic. The variable here is the posted speed limit.

**[0738]** Detecting Traffic Congestion

Traffic congestion that can be alleviated by a controllable traffic control device must exist at the geographic site of the device. In other words, a device cannot alter congestion for which its function plays no role. The congestion must be co-located at the devices location, or in its field of control. Many devices have a range of control. The specific devices must have their characteristics programmed into the software. These characteristics include range and in what direction, that the device affects flow control. Also, the flow control depends on the type of device.

**[0739]** To detect the traffic congestion the traffic control software must know the location of each device. The system must then know the range and direction to monitor for congestion.

These characteristics, as described above, will allow a profile to be sent to the LTS for each device. The LTS can return the traffic density and average velocity of the mobiles in this region. This information will show the levels of congestion. There should be limits at which the system will modify default values. It should not be necessary to modify the defaults if there is little congestion, as it would result in little or no change to the roadway traffic.

**[0740]** More specifically, for a generic system, the traffic can be monitored in all indicated directions for the defined distance for each. Some default traffic density value should be defined for all directions. Some speed value for traffic can also be assigned. Four possible methods of congestion can be used. The first is to use the system in the DAN. The second is to look at the average velocity of the devices on a roadway. The third is to look at the density of the mobile devices against some default value. The fourth is to look at both the density and the velocity of the devices. Using the fourth method, a formula such as multiplying the average speed and density together to result in a number could allow a basis for more accurate congestion detection. Again a default value could be defined as to indicate when it is exceeded that traffic congestion is bad. An additional value that indicates the severity of congestion could be the percent that the roadway is congested over its default value.

**[0741]** These methods should be chosen based on need and function on any particular design. Further in this description, it will be implied that this method results in two categories, pass and fail. Pass is that the threshold is not met and normal traffic exists. Fail indicates that the limit has been exceeded and the traffic is above tolerable limits.

**[0742]** Described as follows are methods to control and alleviate congestion based on device type.

**[0743]** Methodology for Alleviating Congestion

Various methods are needed based on the type of traffic control device. Described for each classification of device, are the methodologies to reduce congestion.

**[0744]** Intersection Traffic Control Lights

The congestion of traffic control lights should be monitored in the direction of the lighting system along the intersecting roadways for a reasonable distance. This distance can be defined and included in software programming, but a typical value may be 50% of the distance to the next intersection controlled by a traffic control light. This value could vary from one traffic lighting system to the next.

**[0745]** The system should start by analyzing traffic congestion along all roadways at the intersection. The roadways should then either be classified as pass or fail. All fail roadways should have a percentage calculated that indicates the amount over the default value that they are congested. To alleviate the traffic, the roadways that are above the limit should be placed in order of descending percent over-congestion. The most congested roadways should have the timing adjusted such that they are allowed additional time on the crossing direction of the intersection. This would represent a longer green light. This would also scale the turn signal direction. The time increase could be proportional to the percent over-congestion. The second, and descending congestion roadways could function in a similar manner, but give less than the same increase. The roadways with no congestion would have the time crossing decreased.

**[0746]** One additional factor is the time to cycle between all roadways (green light offered for every roadway in intersection). This should increase by some defined amount based on the number of congested roads. There should be a limit though programmed into the software. All timings for individual directions should sum up to this time. To accomplish this, it would be necessary to decrease the total time allowed for crossing on the non congested directions, when and increase occurs in the congested directions. Note, that if no directions are congested, then no changing in timing occurs.

**[0747] Highway Inlet Traffic Control Lights**

This system is relatively simple and is based on the ability of the traffic control system to use the LTS to determine only the traffic density of the roadway that the inlet lets into. The density should examine the average density along the roadway, again using some distance defined for the inlet control device.

**[0748]** The period that the device allows cars to pass is inversely proportional to the density of the traffic along this distance. A set of criteria should be established that would adjust the timing for various densities. Lesser densities mean more cars per unit time can safely enter the highway. The converse is similarly true. These exact timings depend on particular roadways and should be unique to every device and configured initially based on field experiments. Below is an example that demonstrates these criteria for a generic system, using generic values:

Traffic Density	Inlet Entrance Rate
10 cars/100m	20 cars/minute
20 cars/100m	15 cars/minute
30 cars/100m	10 cars/minute
40 cars/100m	5 cars/minute

**[0749]** Variable Speed Limit Roadway Signs

This is a method very similar to above, but is mainly a safety feature that can reduce the possibility of an accident, and thus the primary cause for traffic delays, roadside accidents. The system is inversely proportional to traffic density as above. The system should poll the LTS for device density for a distance defined for the specific device. The speed then should be adjusted to levels that are safe for various traffic densities. As cars are closer together, the safe speed limit decreases. Various brackets of speed to indicate for various ranges of traffic density could be defined and integrated into the software. The traffic control software then can automatically adjust the speed values based on traffic density.

**[0750]** Basic Software Requirements

The software architecture of this system is designed so it can be collocated at the MTX or virtually hosted elsewhere but assessable to the MTX. The software should have access to the LTS and have subroutines written to allow it to submit tracking queries to the LTS to determine traffic density and other necessary factors.

**[0751]** The system should be designed to have an administrator's option to enable and disable the system and any particular devices. The system should allow a device to be added and all its

parameters added as well. As each device is added, a device ID can be associated. This device ID would allow each device to be distinguished among each other. The system could then send electronic signals to the devices through direct or indirect routes to modify parameters on each device. These routes can be custom design or pass over public or private networks that connect the two points. The devices and their modification methodology are not the focus of this patent, however these devices are commonly known technology and software can easily be integrated into this that allows remote control to occur.

## **CALL ROUTING SYSTEM**

### **Overview**

**[0752]** The call routing system allows a user to have calls that are intended for the user's mobile device, routed to alternate location, based on the current location or the device and its proximity to the said alternate locations. The user has the option to supply the phone numbers of devices that the user would like it devices to auto-route incoming calls to when the user is near those locations, and when the feature is activated. The user also submits a geographic distance from the device that when the user's device enters into, will activate the routing feature and allow the user the option of having its calls routed to the new device (user is asked if the new location, is acceptable for routing by SMS or similar 2-way message from server). When the user exits the region near the device (as listed in his preferences) the system again asks if the user wants call to be routed back to the user's mobile device. If the user has no devices near them, a feature also allows nearby public devices to be offered to the user as alternate locations for routing.

**[0753]** The call routing system also allows for outgoing call routing which allows a user, service provider or manufacturer to route outgoing calls to selected phone numbers based on the location of the wireless device. For example, if a user dials "911" for emergency services, the call will be routed to the closest "911" call center, based on the location of the wireless device. An other example of the outgoing call routing system would be a user accessing the internet. When the user dials to connect to the internet, her call may be routed to a local internet access number based on the location of the wireless device. This outgoing call routing system will enable a user of a wireless device to optimize the use of his wireless device by receiving better service at a lower cost.

**[0754] System Design and Function**

For the routing system to function, the system must deploy its software at the MTX of a cellular provider. An alternate location on a intranet or internet is possible, but would require the MTX to link to that service and transport method. The software would rely on a service such as the LTS to allow monitoring and tracking of mobile devices. It also requires a database of user preferences that include: routing numbers and distance from routing numbers to activate routing. Authentication and other system level information for users should also exist. A plurality of users may activate the system, and the system will function for all active users. The LTS acts as an cooperative program that helps the current embodiment in many ways, as listed below. This software requires the flowing methods and function as listed below to be carried out to function properly.

**[0755] Determining Location of User**

To allow the system to operate the user of a mobile device must have his or her devices location monitored by the network. To do this, various methods exist such as the directional assistance network (DAN). The DAN allows a device to be monitored for location and additionally allows system events to be triggered based on the location of the device. The main requirement is that the location of the device be stored in a database or other location such that an external program can queue this information. A possible way to implement this is to use a User Location Database or a User Location Database Network. Other methods would be direct querying of the MTX or BSC to determine the location of a said mobile device, or a mobile device equipped with location information such as GPS or triangulation.

**[0756] Determining Phones Near to User**

To determine the fixed phones near a mobile device the system must first obtain the location of the said mobile device. When the system, using any of the above methods as further explained in accompanying documentation (on LTS, ULD, ULDC), has acquired the devices location, it stores it to a temporary register (software variable). The system must then check the user preferences, as stored in a local or remote configuration file, to determine the routing protocols. In this case, it must check the configuration to see if the user has indicated a phone number to route calls to. If no number exists then the system can attempt to route the call to any public



telephone device in the vicinity. Routing to a private phone system would also be possible, but security and privacy concerns would hamper this. But for completeness, the methodology here applies to all cases.

**[0757]** If the system checks the configuration and no devices are listed, or no devices near the mobile device (near implies a distance parameter that is in the configuration file) exist, then the mobile devices can be sent a message alerting the user that private devices were found. If this is the case, then the user can reply with three options:

- Route to nearest public device
- Route to new private device (user must enter new device ID)
- Turn off Routing

**[0758]** Determining Public Phones Near to User

The user has the option to have the call routed to the nearest public device. If the user chooses this option than the system would query the PSTN and retrieve all public phones within the following parameters. The system currently would have the geographic location of the mobile device. Using the PSTN's public phone network database it would query for a list of devices within the mobile devices telecommunication sub-region. These sub-regions are determined by the telecommunications company, and having indicated a particular region, the system can then retrieve all public device phone numbers.

**[0759]** Having done this, the phone numbers can then be submitted again to the PSTN to resolve their addresses. Using commonly known techniques the system can then calculate the distance form the user (user's device) to the public phone(s) retrieved from the PSTN. The nearest device would then be chosen. This device and its address would then be sent to the user via the messaging capability of the phone, possible using wireless internet or other e-mobility techniques. The user may accept or reject the location. If the user accepts the location then the user would have calls that were routed to his mobile devices, rerouted to the public device. If the user rejects the location, subsequent locations based on distance can be presented (closest to furthest). The user may again either at any time, add a private number, accept the public location, or turn off routing.

**[0760] Determining Fixed (Private) Phones Near to User**

If the user has entered a list of private numbers in the configuration file, or adds a private number when no device in its proximity is found, the system can apply a simpler technique than above. The system can use the features of the LTS to its advantage by setting alert modes. These alert modes will be to create a custom tracking criteria for the device. The tracking criteria would be to create circular regions with a radius found in the configuration file, and instruct the LTS to alert the program when a user enters/exists these regions. Thus two options can exist when a user activates tracking: a user turns on tracking while in a region, a user turns on tracking while not in a region. If the user is not in a region then the system will not receive a message from the LTS, it can then as above, ask the user if they wish to search for a public device.

**[0761]** A second option should be to allow the user to disable public device searching. Thus, a user may not be near a routable location (based on locations in a configuration file) but when a user does enter a region, the system will be alerted by the LTS. When the system is alerted of a user entering a specific region near a listed private phone, then the system will route calls to this device. Conversely, when the user exists this region, the LTS will again notify the system and the users calls will not be routed. As before with the public system, the user (user's device) will be sent a message to ask if routing preferences should be changed. The user can chose to accept new routing or decline it. If routing is declined, then the system will ignore the LTS alert when the user exists the region of the private line. It should however then receive the alert when a user enters another private device region and again prompt the user.

**[0762] Determining Mobile Phone Near to User**

When in the above case a user places in his configuration, or when prompted to add a private device (via a message sent to the mobile device), a routing destination that is itself a mobile device the system must add another subroutine to handle this. The procedure above for a private fixed land phone is the same until the location for the device at the PSTN is queried. At this point, the PSTN would return a result that indicates that the device is a mobile phone. The PSTN would also indicate the service provider for the device.

**[0763]** With this information there are 3 different ways to obtain the location of the device. The

first approach is to use the ULDC network to retrieve the devices location. A second, is to query the service provider (possibly the same service provider as the active user) through a cooperative data sharing agreement and retrieve the mobile location on a ULD. The third option is to directly query a BSCIMTX for information to resolve the mobiles location.

**[0764]** When the tracking system is activated, all number indicated to be mobile numbers will require the system to periodically refresh the location of the devices. This time between refreshing can be configured by a system configuration parameter. When the device is refreshed, a new tracking criteria will be submitted to the LTS and the old criteria deleted. Besides these alteration, the system works just as it did for the land fixed device routing.

**[0765]** System Routing Change

When the mobile device has a new forwarding location the system then forwards this new phone number to the routing ability function of the cellular network. This allows external requests from outside the MTX (incoming calls) to be forwarded to a new number supplied from the current embodiment.

**[0766]** Methods to Alert User of Device of Routing Information

Many methods in current software and hardware designs of cellular networks exists to allow 2 direction communication from a software program on a MTX/Intranet to communicative with a mobile device. Methods which exist now that can accomplish the necessary tasks are:

- SMS
- Wireless Internet
- WML
- Proprietary Software

**[0767]** These methods would require the user to respond in some cases. The system would then receive a response from the user, which would contain the users phone ID thus allowing the system to route the response to the particular mobiles preferences and routing queues.

## GEOGRAPHIC ADVERTISING SYSTEM

### Summary

**[0768]** The geographic advertising system (GAS) is a geographically based advertising system which enables the delivery of targeted advertising to and from wireless device users based on their geographic location. GAS monitors the movement of wireless users via monitoring hardware and software connected to a wireless network or user location database, and when a wireless device meets a certain criteria, the wireless device user may be targeted for an advertising solicitation. For example, a user of a wireless device who has traveled outside his home calling area, may receive a text message on his wireless device telling him of a discount on a hotel room in the area.

**[0769]** A business initiated solicitation to a wireless device may be triggered by:

- Distance between wireless device and soliciting business
- Location of the wireless device's home calling area
- Demographic information (age, sex, race, etc.)
- Historic travel patterns
- If wireless device is currently geographically located at a particular location (For example, shopping at the competition's store)
- Other defined criteria

**[0770]** The solicitation may be delivered by;

- A text message to the wireless device
- A phone call to a wireless device
- A message deposited in the users voice mail
- An e-mail
- Postal mail

**[0771]** A user of a wireless device may also initiate a solicitation by, for example, requesting the prices of hotel rooms within a given geographic radius.

[0772] For a user initiated solicitation, the user may sort by:

- Type of goods and services
- Name of business providing goods and services
- Price of goods and services
- Distance to goods and services
- Other defined criteria

[0773] This GAS can work in conjunction with the DAN or other mapping software to provide driving directions, for example, to the hotel which is soliciting the user.

[0774] ACRONYMS

BSC .....	BASE STATION CONTROLER
BSS MANAGER.....	BASE STATION SUBSYSTEM MANAGER
BTS.....	BASESTATION TRANSCIEVER SUBSYSTEM
GPS.....	GLOBAL POSITIONING SYSTEM
HLR.....	HOME LOCATION REGISTER
MTX.....	METROPOLITAN TELEPHONY EXCHANGE
PSTN.....	PULBLIC SWITCH TELEPHONY NETWORK
RF.....	RADIO FREQUENCY
RSSI.....	RECEIVE STRENGTH SIGNAL
TDOA.....	TIME DIFFERENCE OF ARRIVAL
ULD.....	USER LOCATION DATABASE
ULDC.....	USER LOCATION DATABASE COORDINATOR
ULDCN.....	USER LOCATION DATABASE COORDINATOR
NETWORK	
ULDM.....	USER LOCATION DATABSE MANAGER

**CLAIMS**

**WHAT IS CLAIMED IS:**

1. A method of providing navigation assistance to a user of a communications device, the method comprising:

receiving, by a directional assistance service, an Internet query initiated at the communications device and directed via the Internet to initiate a request for navigational assistance to a destination;

responsive to receiving the Internet query, determining whether or not the communications device is a mobile wireless communications device;

responsive to determining that the communications device is the mobile wireless communications device, the directional assistance service determining and using a present location of the mobile wireless communications device as a location of the communications device;

responsive to determining that the communications device is not the mobile wireless communications device, obtaining a fixed location associated with the communications device to determine the location of the communications device; and

the directional assistance service providing navigation information to the communications device in response to the Internet query, wherein the navigation provides directions for proceeding from the location of the communications device to a location of the destination.

2. The method of Claim 1, wherein the determining and using the present location of the mobile wireless communications device comprises querying an external user location database of a network of the mobile wireless communications device to determine the location of the communications device.

3. The method of Claim 1, wherein the determining and using the present location of the mobile wireless communications device comprises:

the directional assistance service initiating locating the mobile wireless communications device by sending a query to a switch or base station controller of a wireless network; and

building an internal database storing the present location of the mobile wireless communications device with results of the query and using the stored location as the location of the communications device.

4. The method of Claim 1, wherein the obtaining the fixed location associated with the communications device comprises retrieving the fixed location from a database.

5. The method of Claim 4, wherein the retrieving the fixed location from the database comprises querying a public service telephone network (PSTN).

6. The method of Claim 1, further comprising receiving a user input of a destination telephone number at the communications device, wherein the received Internet query includes the destination phone number, and wherein the directional assistance service determines the location of the destination from the destination phone number.

7. The method of Claim 1, further comprising receiving a user input of a destination address at the communications device, wherein the received Internet query includes the destination address, and wherein the directional assistance service determines the location of the destination from the destination address.

8. The method of Claim 1, further comprising receiving a user input of a name of a business at the communications device, wherein the received Internet query includes the name of the business, and wherein the directional assistance service determines the location of the destination from the name of the business.



9. The method of Claim 8, wherein the user input of the name of the business is a first user input, and wherein the method further comprises:

the directional assistance service providing selection between the first user input of the name of the business or a second user input of a destination telephone number at the communications device;

receiving a third user input specifying selection of either user input of the name of the business or the destination telephone number; and

receiving either the first user input of the name of the business or the second user input of the destination telephone number as a destination descriptor, and wherein the received Internet query includes the destination descriptor, and wherein the directional assistance service determines the location of the destination from the destination descriptor.

10. The method of Claim 1, further comprising:

the directional assistance service prompting the user of the communications device to provide an option for selection of suggested nearby businesses as the destination;

responsive to the user selecting the option for selection of the suggested nearby businesses, the directional assistance service suggesting one or more nearby businesses; and

responsive to a user input selecting a selected one of the suggested nearby businesses, sending the Internet query including an identifier of the selected one of the suggested nearby businesses.

11. The method of Claim 10, further comprising:

the directional assistance service prompting the user of the communications device to provide an option for selection of a category of business for the suggested nearby businesses;

responsive to the user selecting the option for selection of the category of business, sending a prompt for the user to specify the category of business; and

responsive to the user specifying the category of business, the directional assistance service suggesting the one or more nearby businesses matching the category of business.

12. The method of Claim 1, further comprising:

the directional assistance service prompting the user of the communications device to provide an option for selection of tracking another communications device that is another mobile wireless communications device; and

responsive to the user selecting the option for tracking the another mobile wireless communications device, the directional assistance service sending the Internet query with an identifier of the another mobile wireless communications device.

13. The method of Claim 1, further comprising:

the directional assistance service prompting the user of the communications device to provide an option for selection between providing one of a destination telephone number, a destination address, a destination business or a category of business;

responsive to the user selecting the option for providing the destination telephone number, receiving a second user input of the destination telephone number, wherein the received Internet query includes the destination telephone number, and wherein the directional assistance service determines the location of the destination from the destination telephone number;

responsive to the user selecting the option for providing the destination address, receiving a third user input of the destination address, wherein the received Internet query includes the destination address, and wherein the directional assistance service determines the location of the destination from the destination address;

responsive to the user selecting the option for providing a category of business, receiving a fourth user input specifying the category of business;

responsive to receiving the fourth user input, the directional assistance service suggesting one or more nearby businesses matching the category of business; and

further responsive to receiving the fourth user input and further responsive to receiving a fifth user input selecting one of the suggested one or more nearby businesses matching the category of business, sending an identifier of the selected one of the suggested one or more nearby businesses in the Internet query, wherein the directional assistance service determines the

location of the destination from the identifier of the selected one of the suggested one or more nearby businesses.

14. The method of Claim 13, wherein the directional assistance service prompting the user of the communications device to provide the option for selection between providing one of the destination telephone number, the destination address, the destination business or the category of businesses further provides an option for locating another mobile wireless communications device, and responsive to the user selecting the option for locating the another mobile wireless communications device, receiving a sixth user input of a telephone number of the another mobile wireless communications device, wherein the received Internet query includes the telephone number of the another mobile wireless communications device, and wherein the directional assistance service determines the location of the destination from the telephone number of the another mobile wireless communications device.

15. A mobile wireless communications network, comprising:

multiple radio-frequency transceivers and associated multiple antennas to which the associated radio-frequency transceivers are coupled, wherein the multiple radio-frequency transceivers are configured for radio-frequency communication with one or more mobile wireless communications devices; and

a directional assistance network coupled to the multiple radio-frequency transceivers, wherein the directional assistance network receives an Internet query initiated at a communications device and directed via the Internet to initiate a request for navigational assistance to a destination and responsive to receiving the Internet query, determines whether or not the communications device is a one of the one or more mobile wireless communications devices, and responsive to determining that the communications device is a one of the one or more mobile wireless communications devices, determines and uses a present location of the communication device as a location of the communications device, wherein the directional assistance network, responsive to determining that the communications device is not one of the one or more mobile wireless communications devices, obtains a fixed location associated with the communications device to determine the location of the communications device, and wherein the directional assistance network provides navigation information to the communications device in response to the Internet query, and wherein the navigation information provides directions for proceeding from the location of the communications device to a location of the destination.

16. The mobile wireless communications network of Claim 15, wherein the directional assistance network determines and uses the present location of the communications device by querying an external user location database of a wireless network to which of the one or more mobile wireless communications devices are connected to determine the location of the communications device.

17. The mobile wireless communications network of Claim 15, wherein the directional assistance network determines and uses the present location of the communications device by initiating locating the communications device by sending a query to a switch or base station controller of a wireless network to which the one or more mobile wireless communications devices are connected, building an internal database storing the present location of the communications device with results of the query and using the stored location as the location of the communications device.

18. The mobile wireless communications network of Claim 15, wherein the directional assistance network obtains the fixed location associated with the communications device by retrieving the fixed location from a database.

19. The mobile wireless communications network of Claim 18, wherein the directional assistance network retrieves the fixed location from the database by querying a public service telephone network (PSTN).

20. The mobile wireless communications network of Claim 15, wherein the communications device further receives a user input of a destination address and sends the Internet query to the directional assistance network including the destination address, and wherein the directional assistance network determines the location of the destination from the destination address.

21. The mobile wireless communications network of Claim 15, wherein the communications device further receives a user input of a destination telephone number and sends the Internet query to the directional assistance network including the destination phone number, and wherein the directional assistance network determines the location of the destination from the destination phone number.

22. The mobile wireless communications network of Claim 15, wherein the communications device further receives a user input of a name of a business, wherein the Internet query received by the directional assistance network includes the name of the business, and wherein the directional assistance network determines the location of the destination from the name of the business.

23. The mobile wireless communications network of Claim 22, wherein the user input of the name of the business is a first user input, and wherein the directional assistance network provides selection between the first user input of the name of the business or a second user input of a destination telephone number via the communications device, wherein the communications device receives a third user input specifying selection of either user input of the name of the business or the destination telephone number and either the first user input of the name of the business or the second user input of the destination telephone number as a destination descriptor, and wherein the communications device sends the Internet query including the destination descriptor, and wherein the directional assistance network determines the location of the destination from the destination descriptor.

24. The mobile wireless communications network of Claim 15, wherein the directional assistance network further prompts the user via the communications device to provide an option for selection of suggested nearby businesses as the destination, and responsive to the user selecting the option for selection of the suggested nearby businesses, the directional assistance network suggests one or more nearby businesses, and wherein responsive to a user input selecting a selected one of the suggested nearby businesses at the communications device, the communication device sends the Internet query including an identifier of the selected one of the suggested nearby businesses.



25. The mobile wireless communications of Claim 24, wherein the directional assistance network further prompts the user of the communications device to provide an option for selection of a category of business for the suggested nearby businesses and responsive to the user selecting the option for selection of the category of business, sends a prompt for the user to specify the category of business, wherein the directional assistance network, responsive to the user specifying the category of business, the directional assistance network suggesting the one or more nearby businesses matching the category of business.

26. The mobile wireless communications network of Claim 15, wherein the directional assistance network further prompts the user via the communications device to provide an option for selection of tracking another communications device that is another mobile wireless communications device, and wherein the communications device, responsive to the user selecting the option for tracking the another communications device, sends the Internet query with an identifier of the another communications device.

27. The mobile wireless network of Claim 15, wherein the directional assistance network prompts the user of the communications device to provide an option for selection between providing one of a destination telephone number, a destination address, a destination business or a category of business, wherein the directional assistance network, responsive to the user selecting the option for providing the destination telephone number, receives a second user input of the destination telephone number in the Internet query, whereby the directional assistance network determines the location of the destination from the destination telephone number, wherein the directional assistance network, responsive to the user selecting the option for providing the destination address, receives a third user input of the destination address in the Internet query, whereby the directional assistance network determines the location of the destination from the destination address, and wherein the directional assistance network, responsive to the user selecting the option for providing a category of business, receives a fourth user input specifying the category of business from the communications device and responsive to receiving the fourth user input, the directional assistance network communicating a suggestion of one or more nearby businesses matching the category of business to the communications device, and receives a fifth user input selecting one of the suggested one or more nearby businesses and sends an identifier of the selected one of the suggested one or more nearby businesses in the Internet query, whereby the directional assistance network determines the location of the destination from the identifier.

28. The mobile wireless communications network of Claim 27, wherein the directional assistance network further prompts the user of the communications device to provide an option for selection of locating another mobile wireless communications device, and responsive to the user selecting the option for locating the another mobile wireless communications device, receives a sixth user input of a telephone number of the another mobile wireless communications device in the Internet query, and wherein the directional assistance network determines the location of the destination from the telephone number of the another mobile wireless communications device.

29. A method of providing navigation assistance to a user of a communications device, the method comprising:

a directional assistance network prompting the user of the communications device to provide an option for selection of suggested nearby businesses as a destination;

responsive to the user selecting the option for selection of suggested nearby businesses, the directional assistance network suggesting one or more nearby businesses;

responsive to a user input selecting a selected one of the suggested nearby businesses, the communications device sending an Internet query including an identifier of the selected one of the suggested nearby businesses.

the directional assistance network receiving the Internet query, wherein the directional assistance network determines a location of the destination from the identifier of the selected one of the suggested nearby businesses;

responsive to receiving the Internet query, determining whether or not the communications device is a mobile wireless communications device;

responsive to determining that the communications device is a mobile wireless communications device, the directional assistance network determining and using a present location of the mobile wireless communications device as a location of the communications device;

responsive to determining that the communications device is not the mobile wireless communications device, obtaining a fixed location associated with the communications device to

determine the location of the communications device by querying a public service telephone network (PSTN) to retrieve the fixed location of the communications device from a database;

the directional assistance network initiating locating the mobile wireless communications device by sending a query to a switch or base station controller of a wireless network; and

building an internal database storing the present location of the mobile wireless communications device with results of the query and using the stored location as the location of the communications device; and

the directional assistance network providing navigation information to the communications device in response to the query, wherein the navigation provides directions for proceeding from the location of the communications device to the location of the destination.

30. A mobile wireless communications network, comprising:

multiple radio-frequency transceivers and associated multiple antennas to which the associated radio-frequency transceivers are coupled, wherein the multiple radio-frequency transceivers are configured for radio-frequency communication with one or more mobile wireless communications devices; and

a directional assistance network coupled to the multiple radio-frequency transceivers, wherein the directional assistance network prompts a user of the communications device to provide an option for selection of suggested nearby businesses as a destination, and responsive to the user selecting the option for selection of suggested nearby businesses, the directional assistance network suggesting one or more nearby businesses, wherein the directional assistance network receives an Internet query initiated at the communications device and directed via the Internet to initiate a request for navigational assistance to a selected one of the one or more nearby businesses as the destination and responsive to receiving the Internet query, determines whether or not the communications device is one of the one or more mobile wireless communications devices, and responsive to determining that the communications device is one of the one or more mobile wireless communications devices determines and uses a present location of the one of the communications device as a location of the communications device by initiating locating the communications device by sending a query to a switch or base station controller of the wireless network, building an internal database storing the present location of the communications device with results of the query and using the stored location as the location of the communications device, and responsive to determining that the communications device is not one of the one or more mobile wireless communications devices, obtains a fixed location associated with the communications device retrieving the fixed location from a database by

querying a public service telephone network (PSTN) to determine the location of the communications device, and wherein the directional assistance network provides navigation information to the communications device in response to the query, wherein the navigation information provides directions for proceeding from the location of the communications device to a location of the destination.

### **Abstract**

A mobile wireless network and a method of operation provide directional assistance in response to an Internet query. The directional assistance is provided from a location of the querying device to a destination that may be selectively prompted based on whether the destination is a nearby business, a type of business, a street address, or another mobile device or fixed telephone location. The location of the querying device is also selectively determined depending on whether the querying device is a wireless device such as a mobile telephone, or whether the device has a presumed fixed location, such as an ordinary telephone connected to a public-switched telephone network (PSTN).



**TYPICAL SECOND GENERATION WIRELESS NETWORK ARCHITECTURE  
(PRIOR ART)**

**FIG. 1**

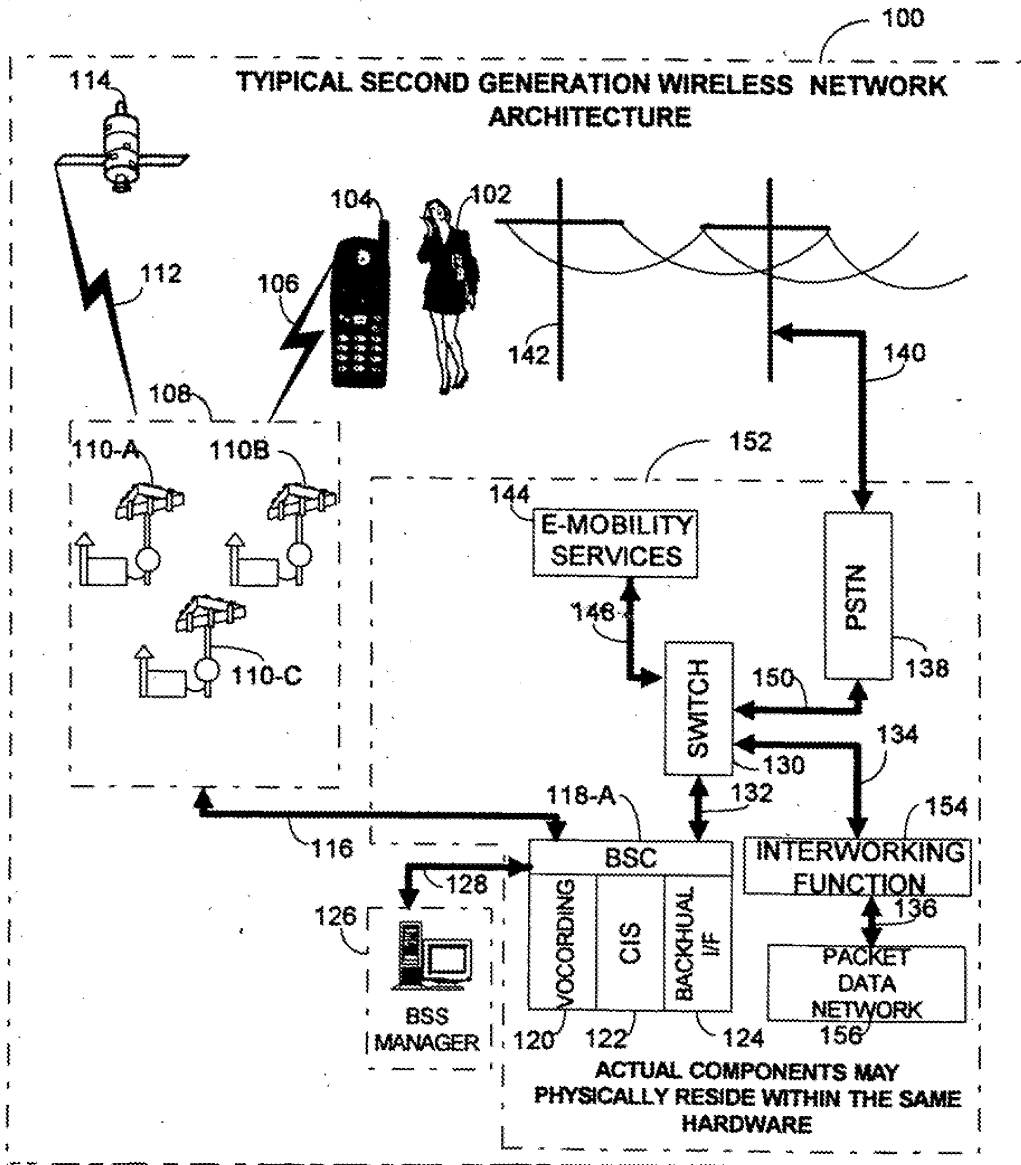

TYPICAL THIRD GENERATION WIRELESS NETWORK ARCHITECTURE (PRIOR ART)

FIG. 2

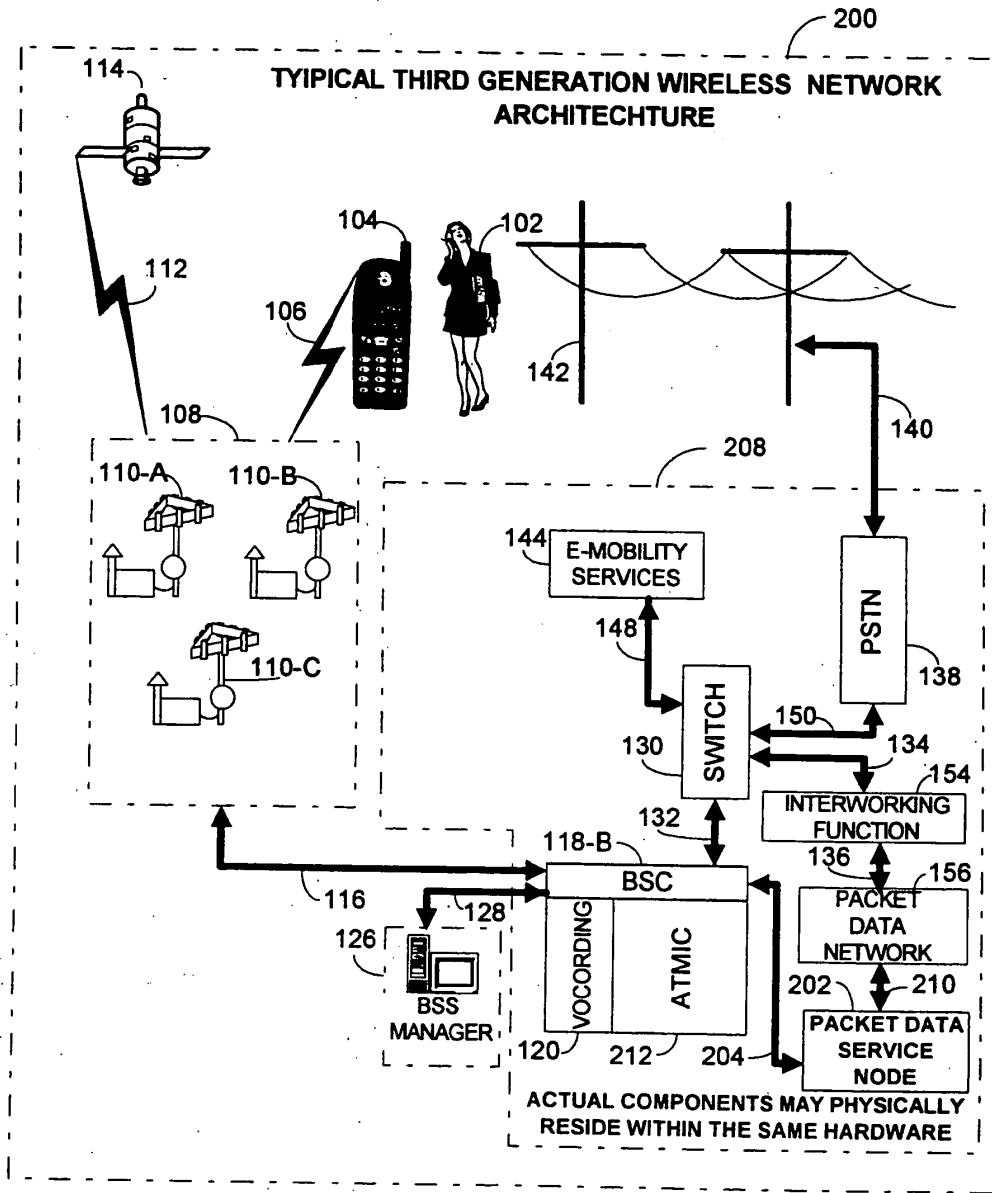

**TYPICAL THREE SECTOR RADIO TOWER  
CONFIGURATION  
(PRIOR ART)**

**FIG. 3**

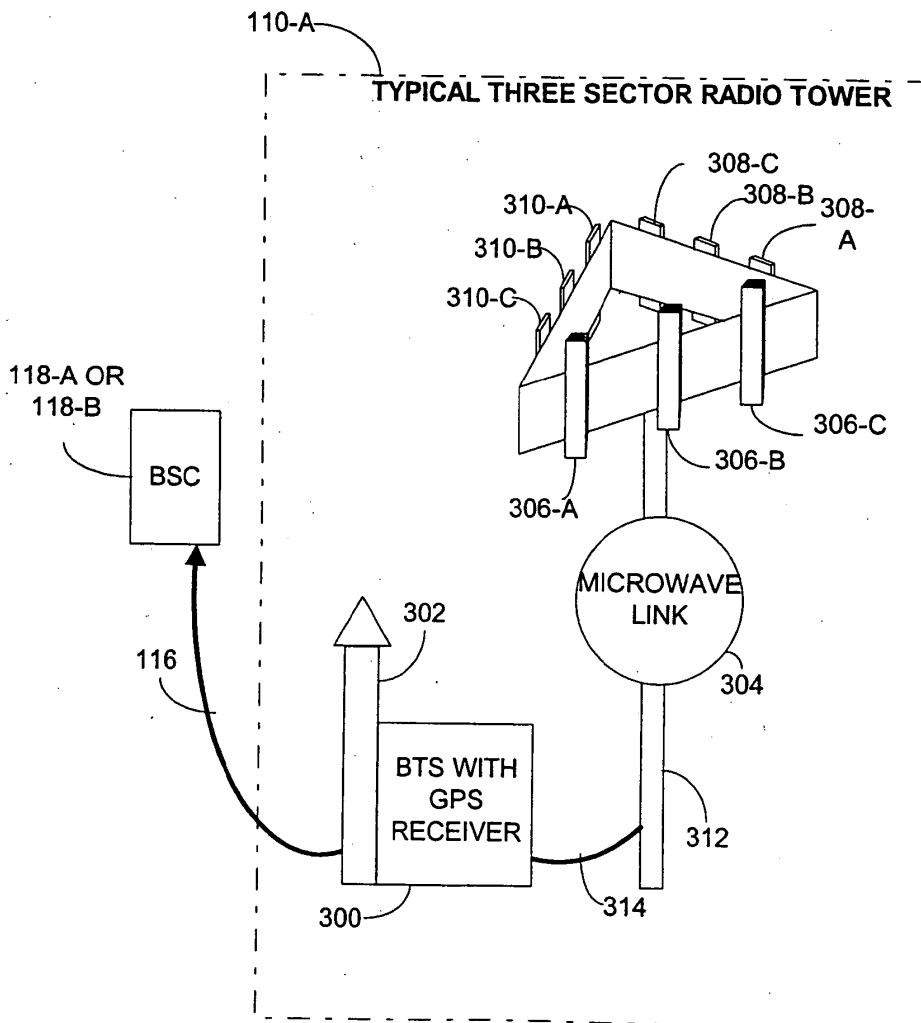

TYPICAL FOOTPRINT CHARACTERISTICS OF EACH SECTOR (SIDE VIEW) *(PRIOR ART)*

FIG. 4

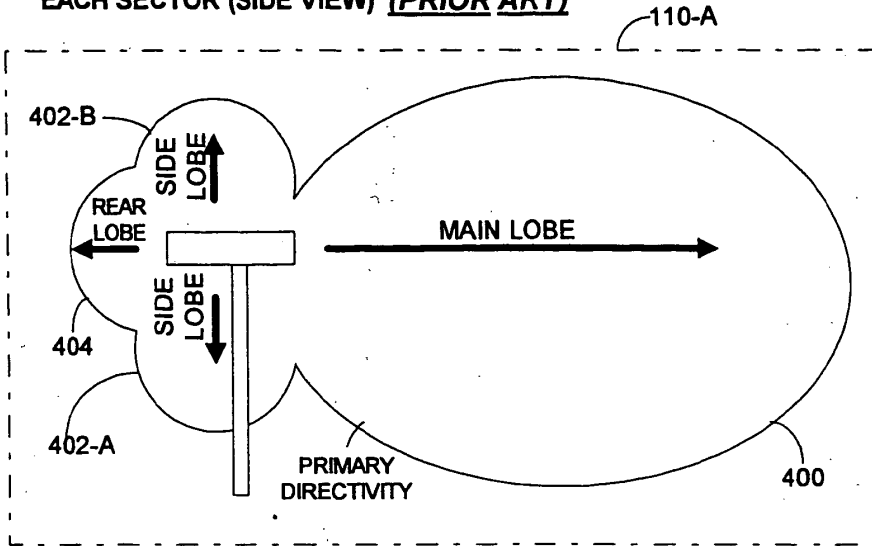

TYPICAL FOOTPRINT CHARACTERISTICS OF EACH SECTOR (TOP VIEW) *(PRIOR ART)*

FIG. 5

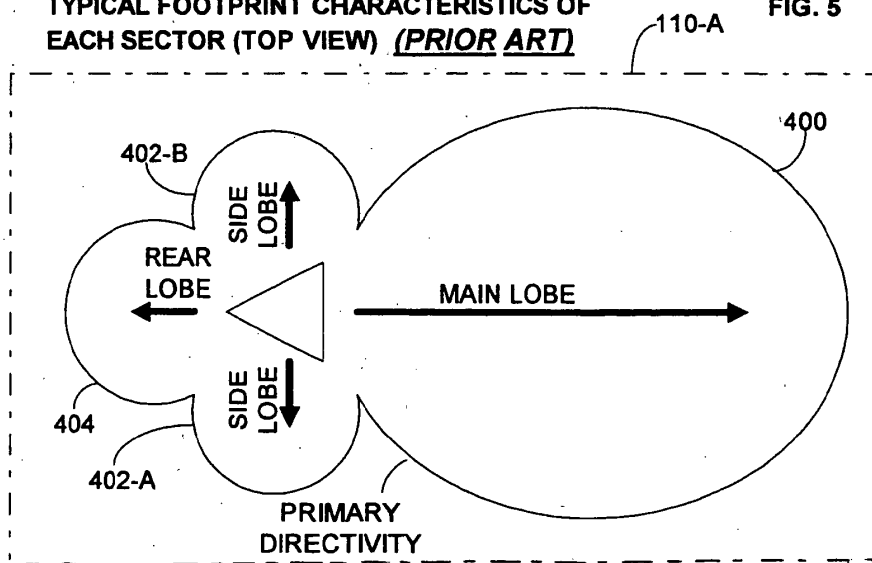

**THREE TOWER LOCATION  
METHOD  
(PRIOR ART)**

**FIG. 6**

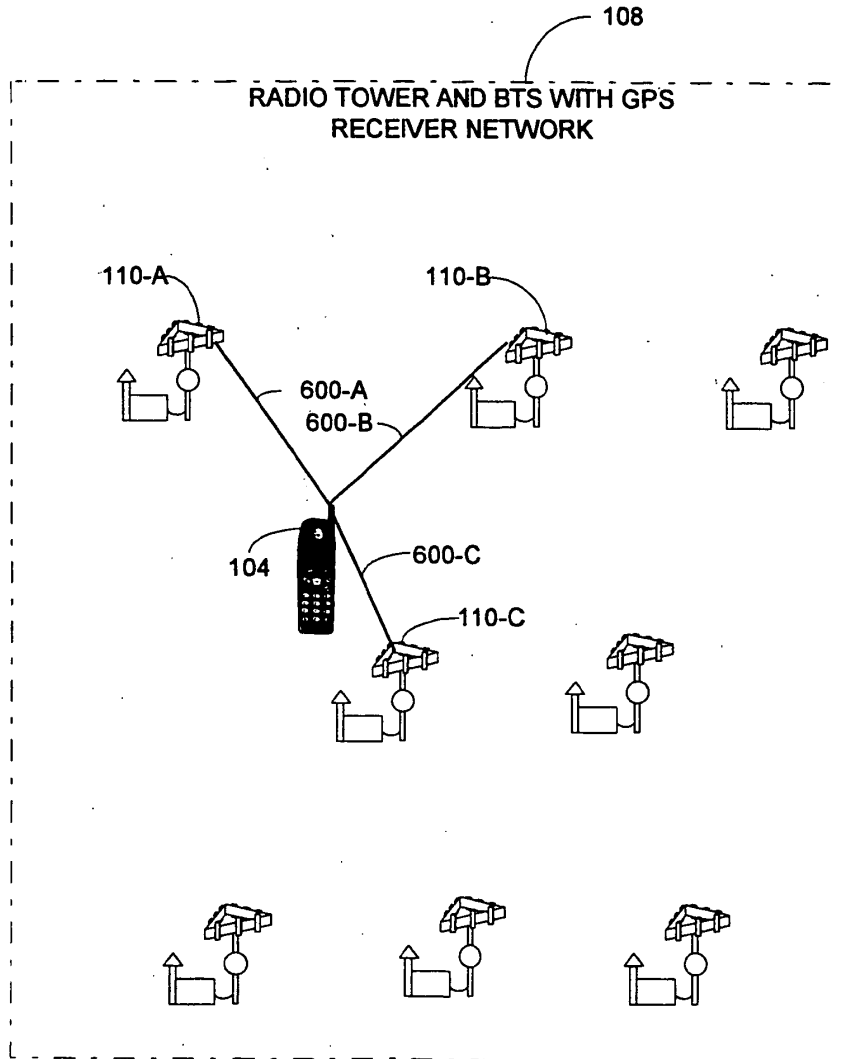

**TWO TOWER LOCATION  
METHOD  
(PRIOR ART)**

**FIG. 7**

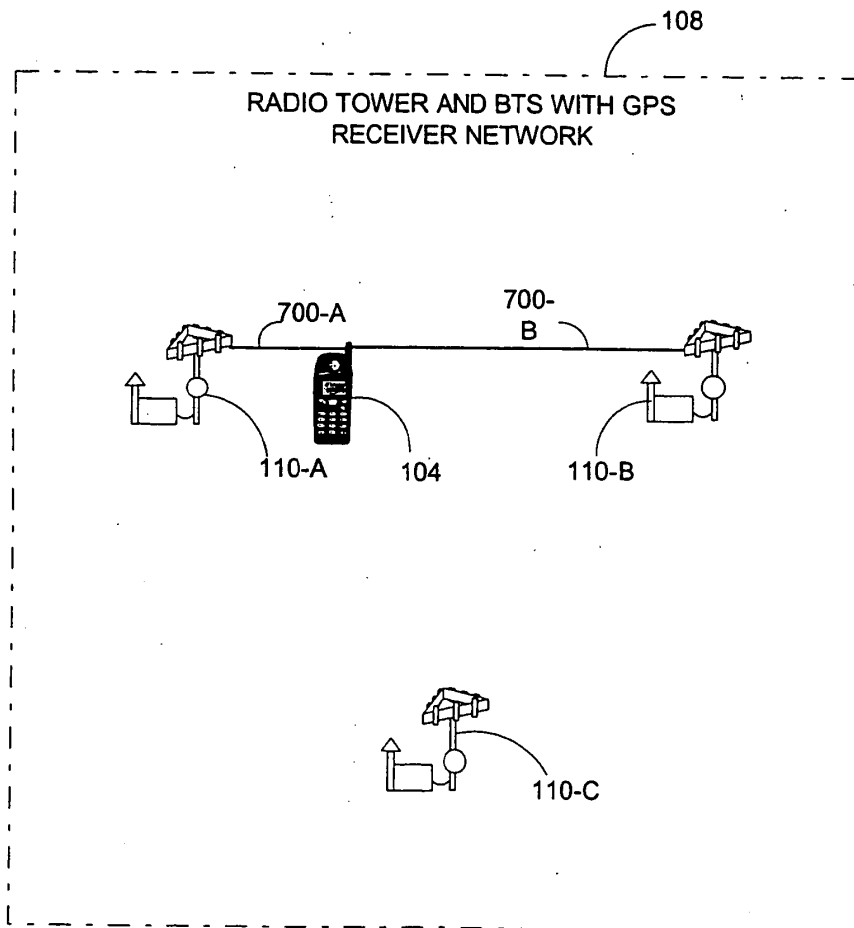

**SINGLE TOWER LOCATION METHOD  
(PRIOR ART)**

**FIG. 8**

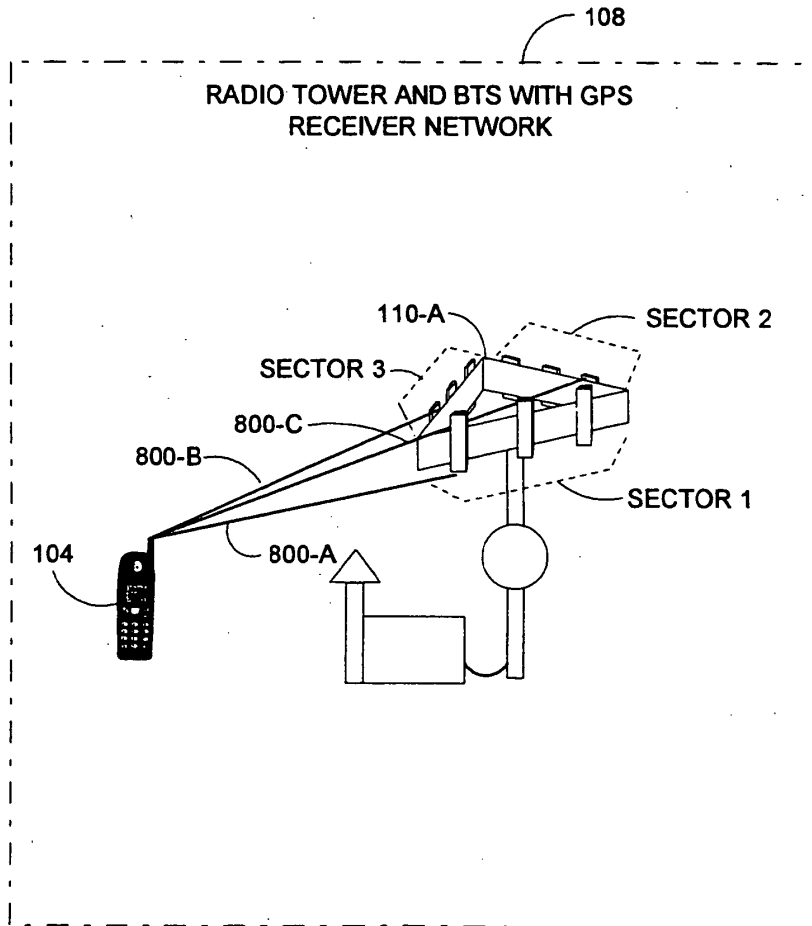

FIG. 9

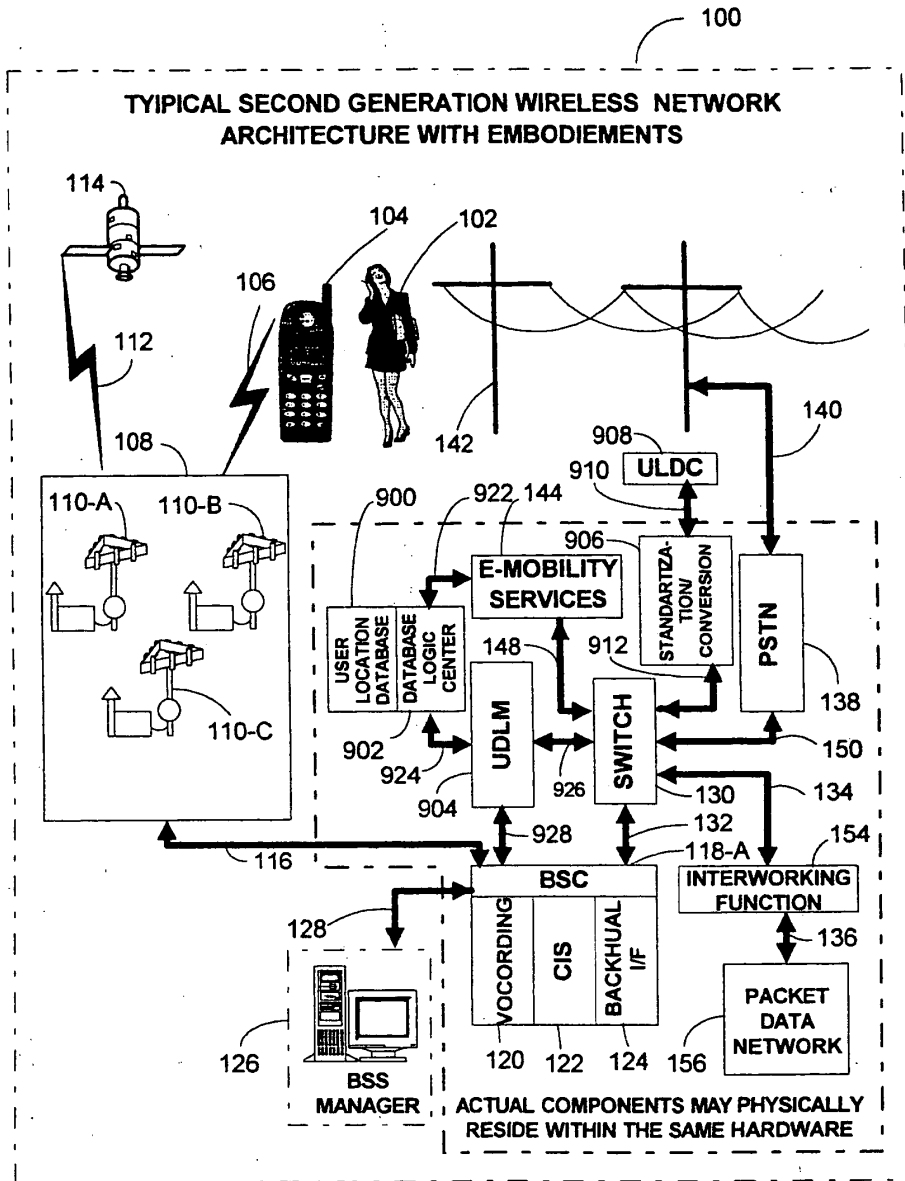
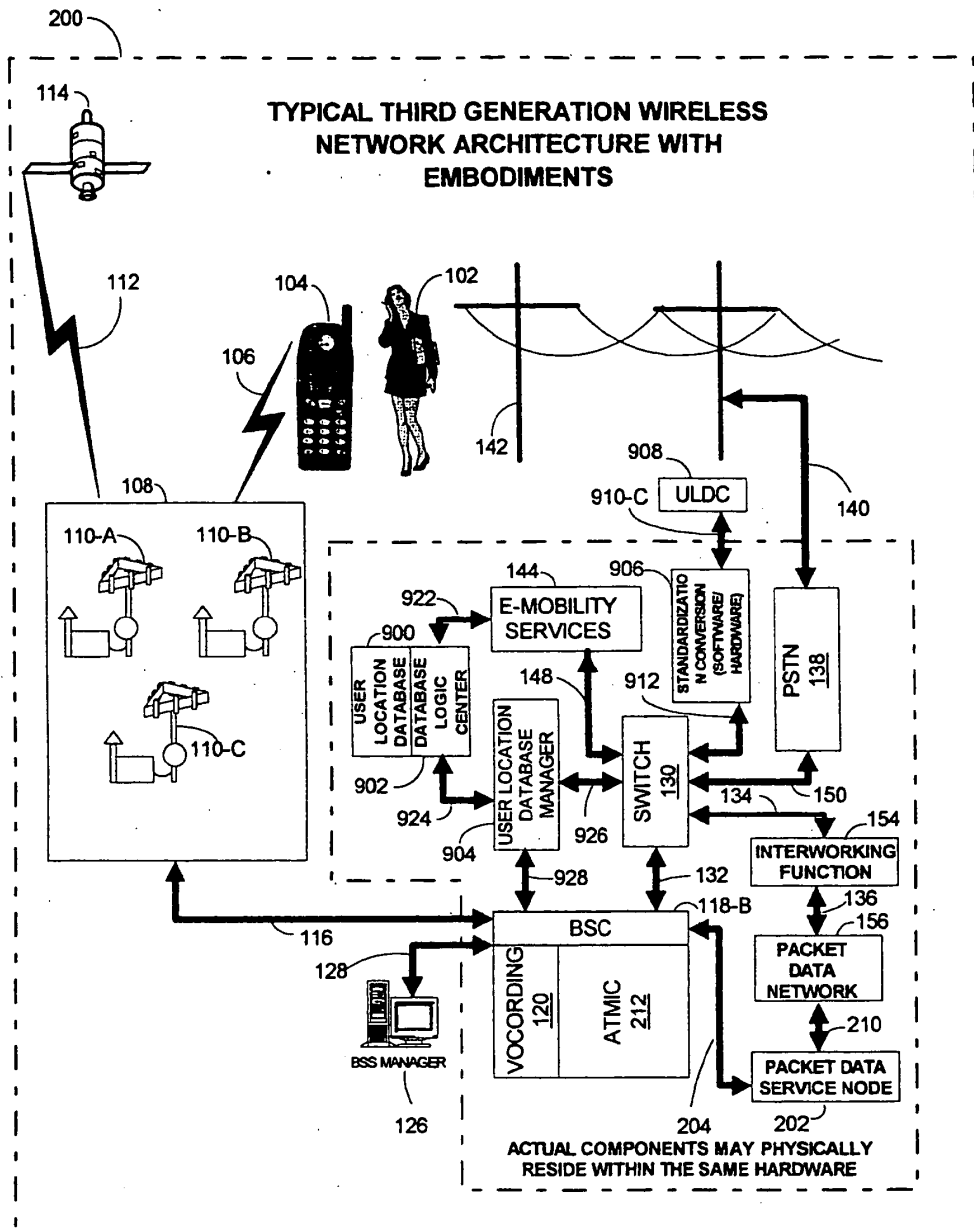

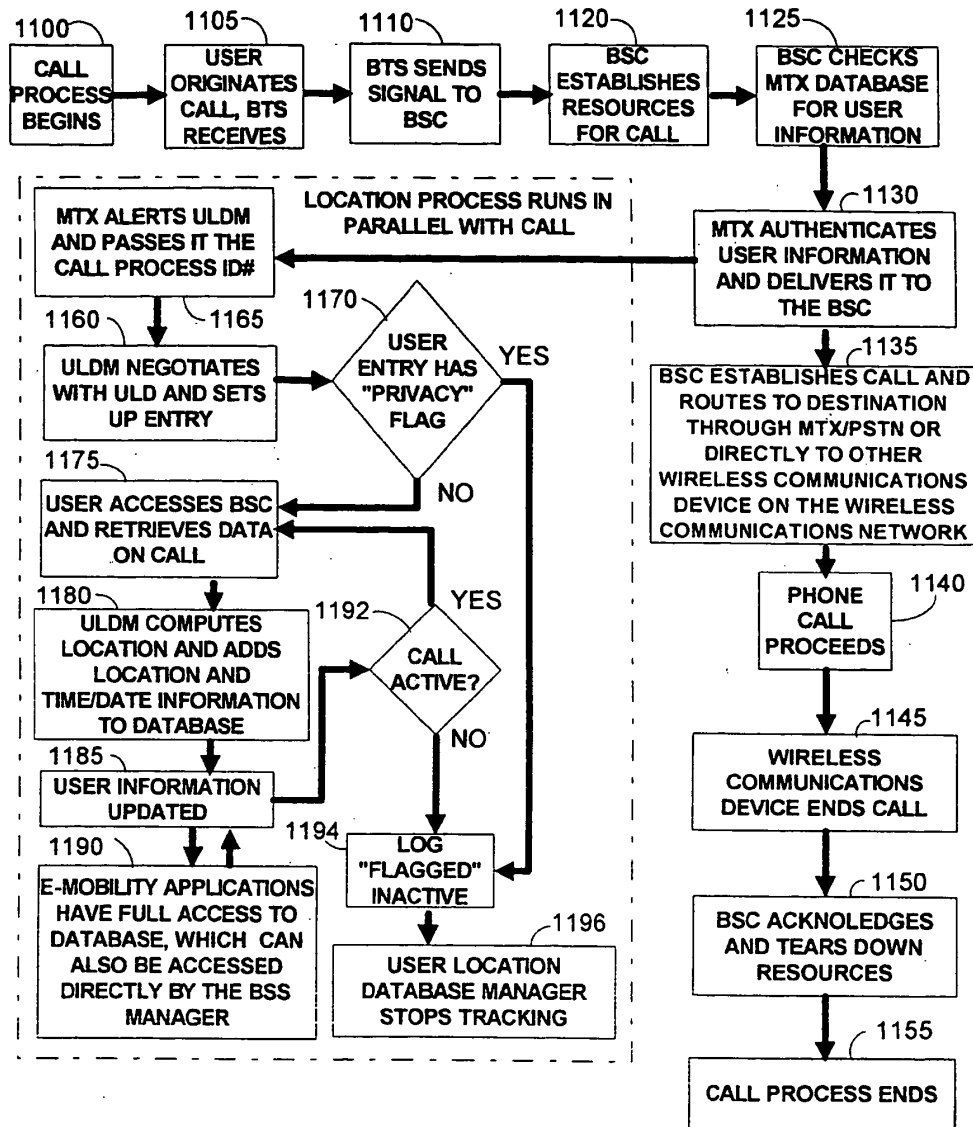

FIG. 10



**FLOWCHART OF TRACKING WIRELESS DEVICES LOCATION**

**FIG. 11**



**INTERWORKING BETWEEN THE BSC, SWITCH AND ULDM**

**FIG. 12**

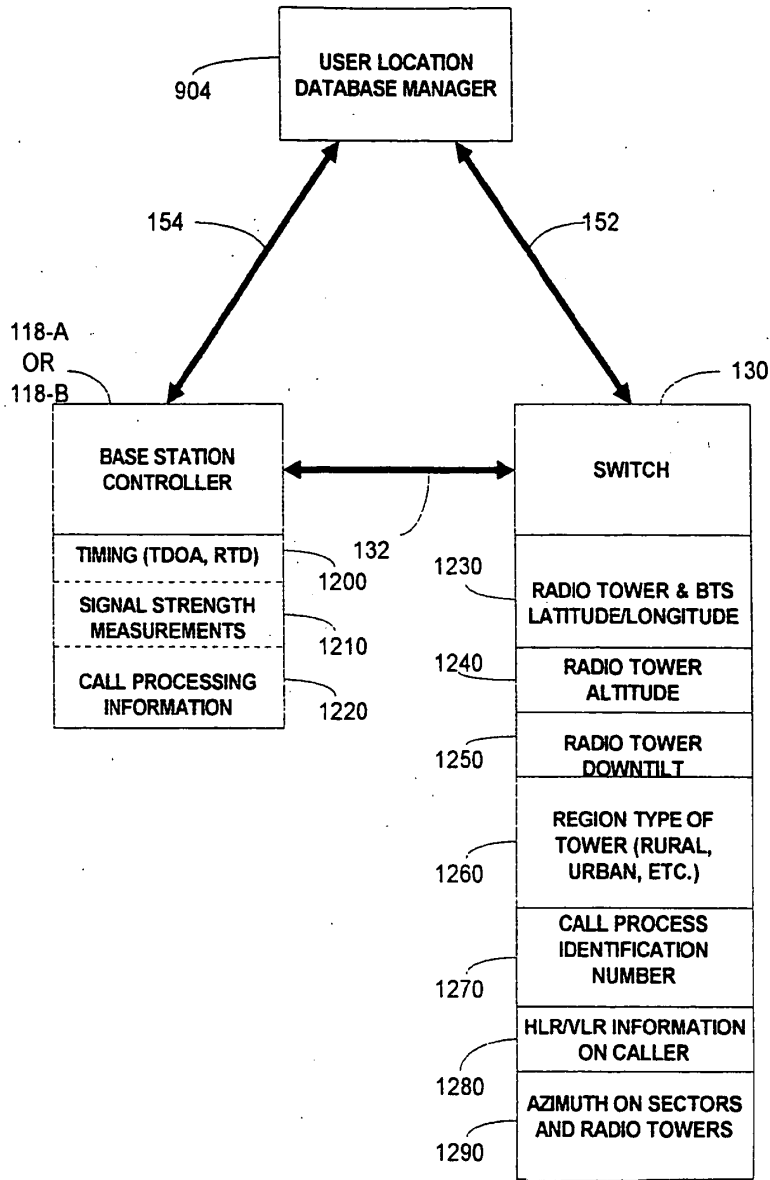

**USER LOCATION DATABASE  
COORDINATOR  
(MARKET LEVEL QUERY)**

**FIG. 13**

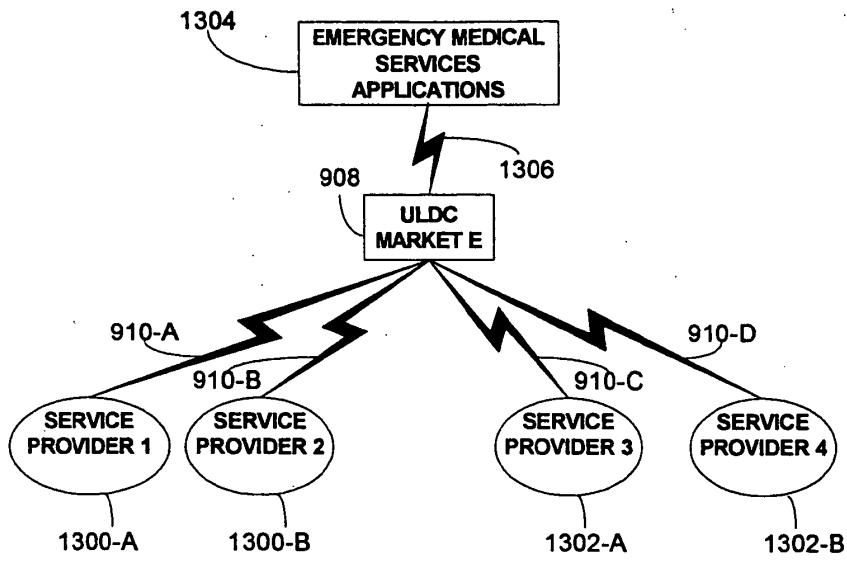

**USER LOCATION DATABASE COORDINATOR  
FLOWCHART**

**FIG. 14**

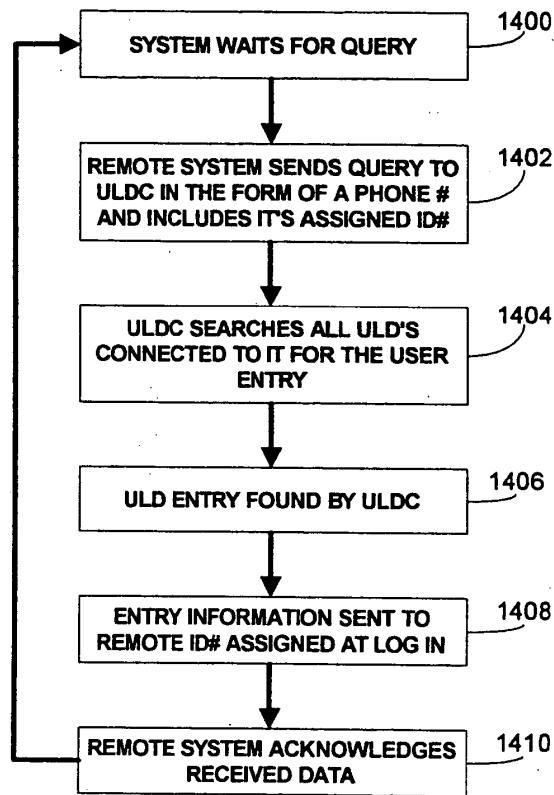

**GENERIC USER LOCATION DATABASE  
COORDINATOR COMPONENTS**

**FIG. 15**

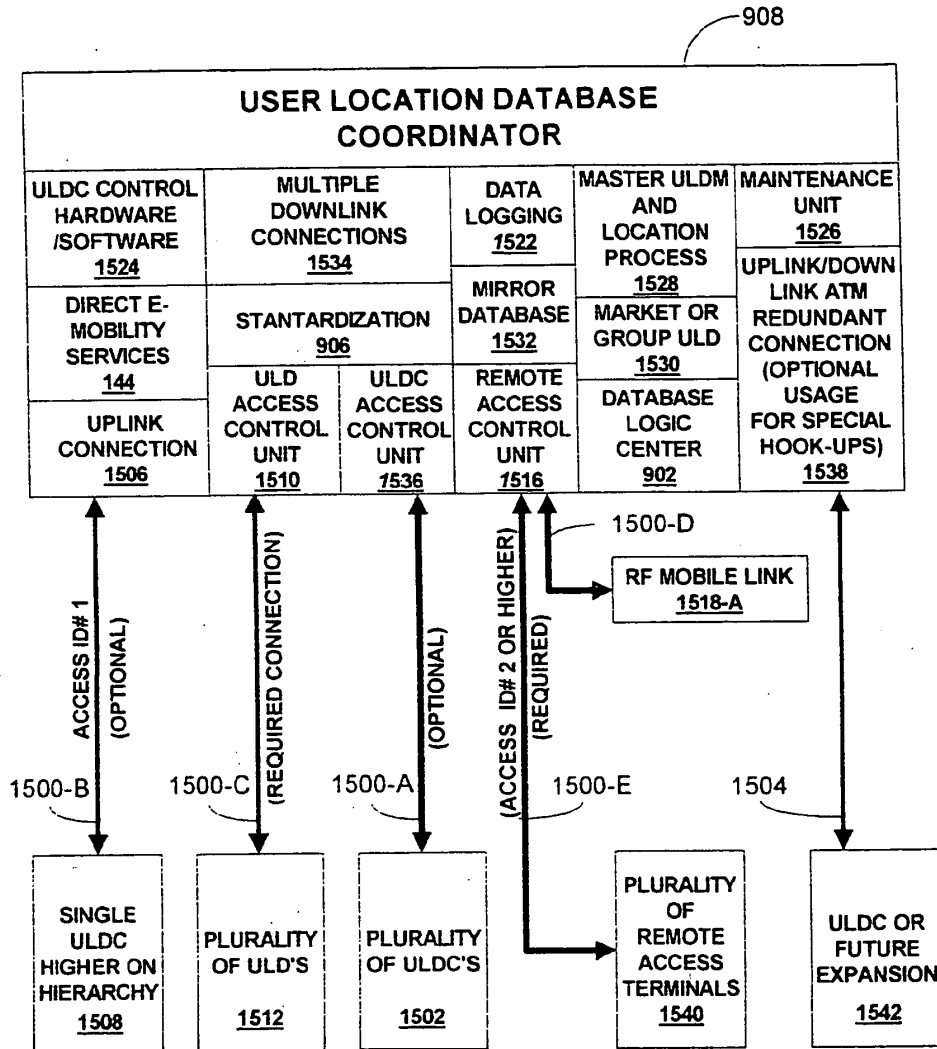

**USER LOCATION DATABASE  
COORDINATOR NETWORK  
(REGION BASED SYSTEM)**

**FIG. 17**

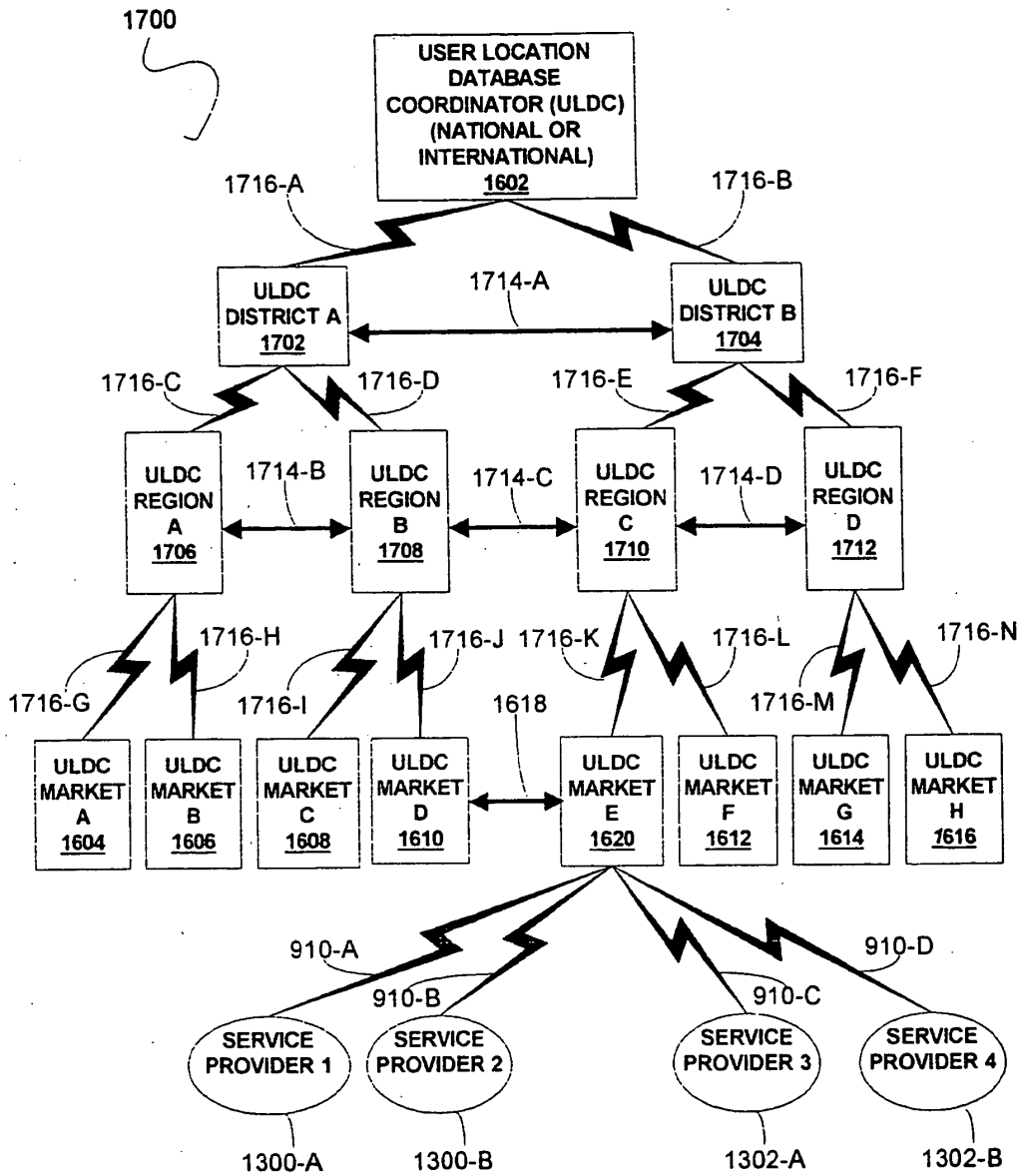

**USER LOCATION DATABASE  
COORDINATOR NETWORK  
(DIRECT SYSTEM)**

**FIG. 18**

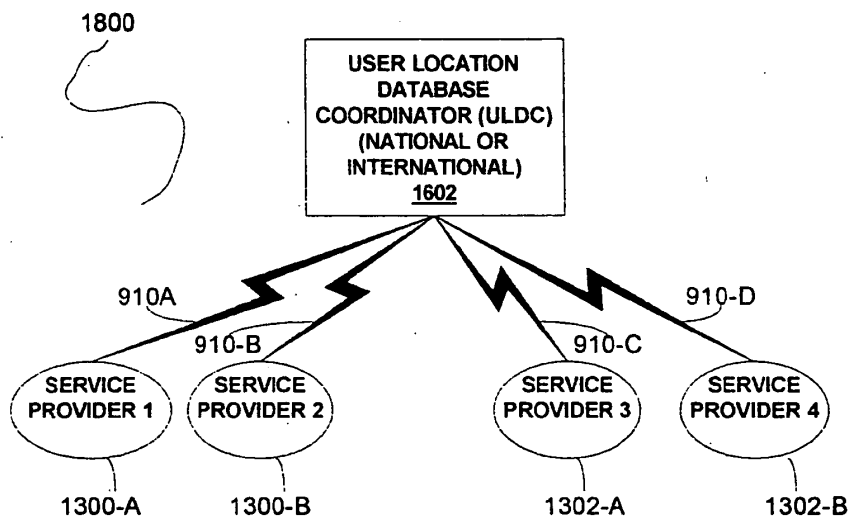



### USER EXTERNAL QUERY CONNECTIVITY

FIG. 19

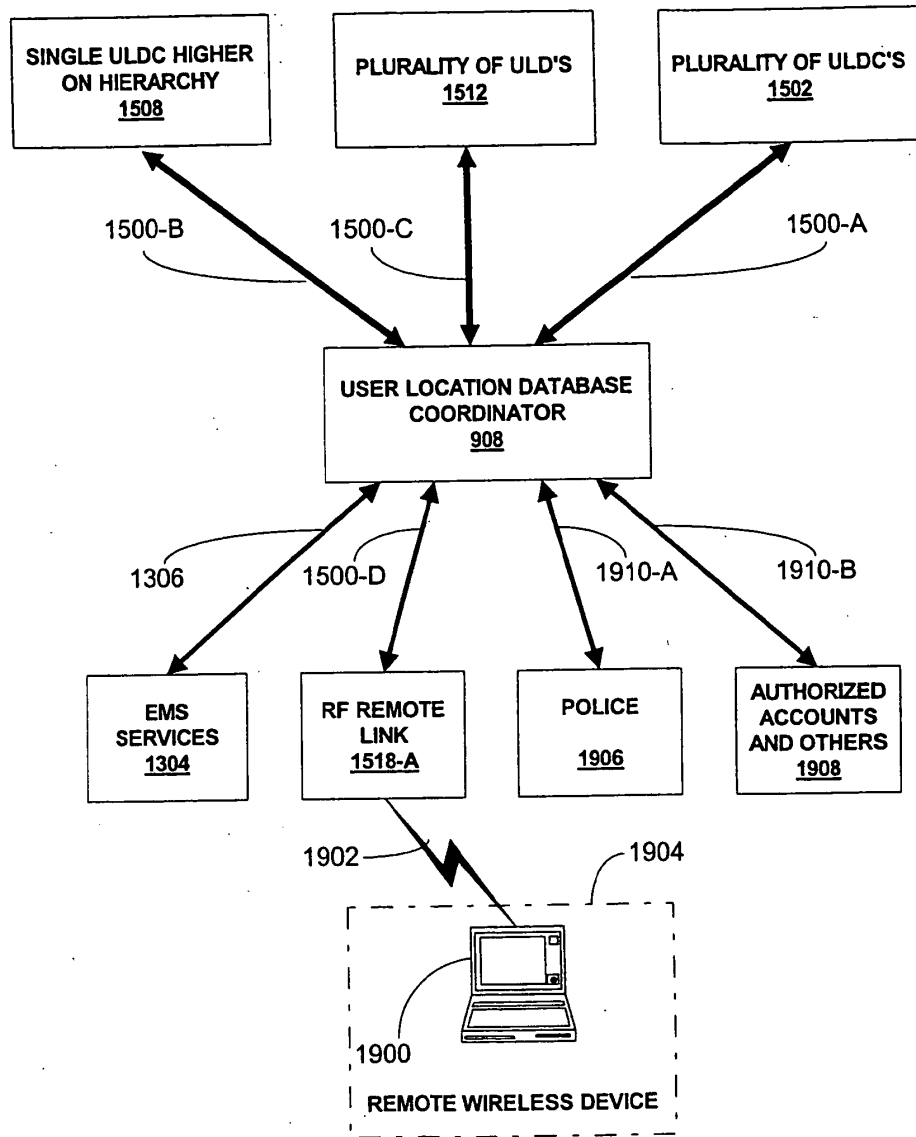

# HIERARCHY OF LOCATION METHODS

FIG. 20

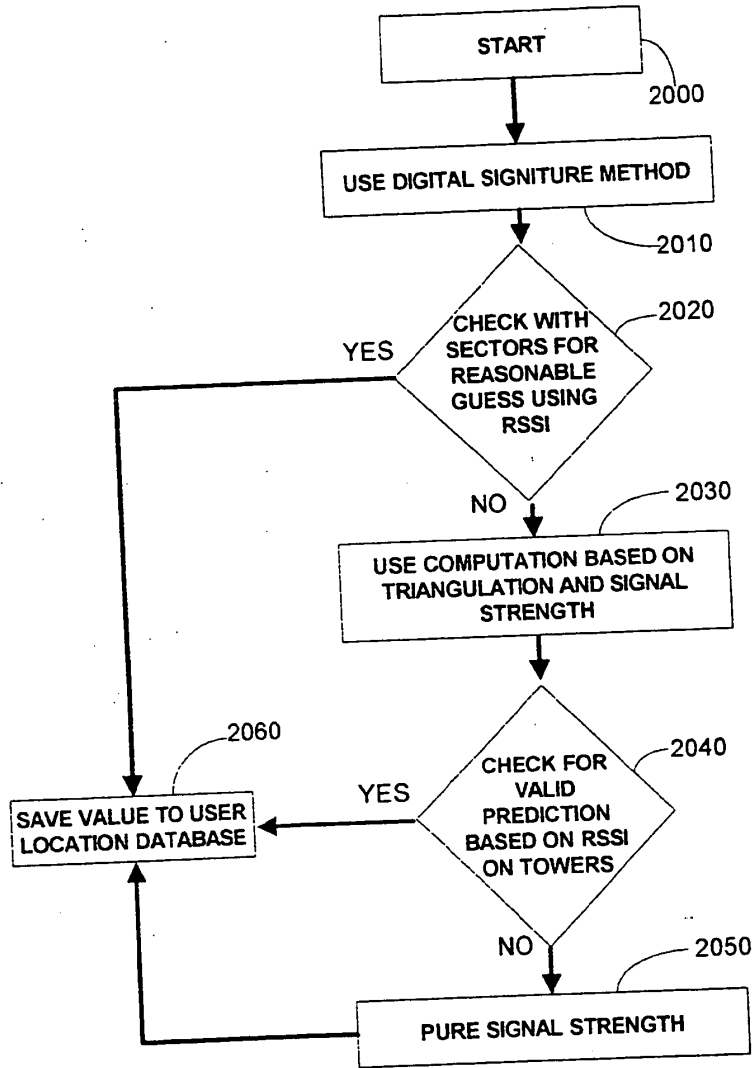

VALUATION OF LOCATION METHODS FIG. 21

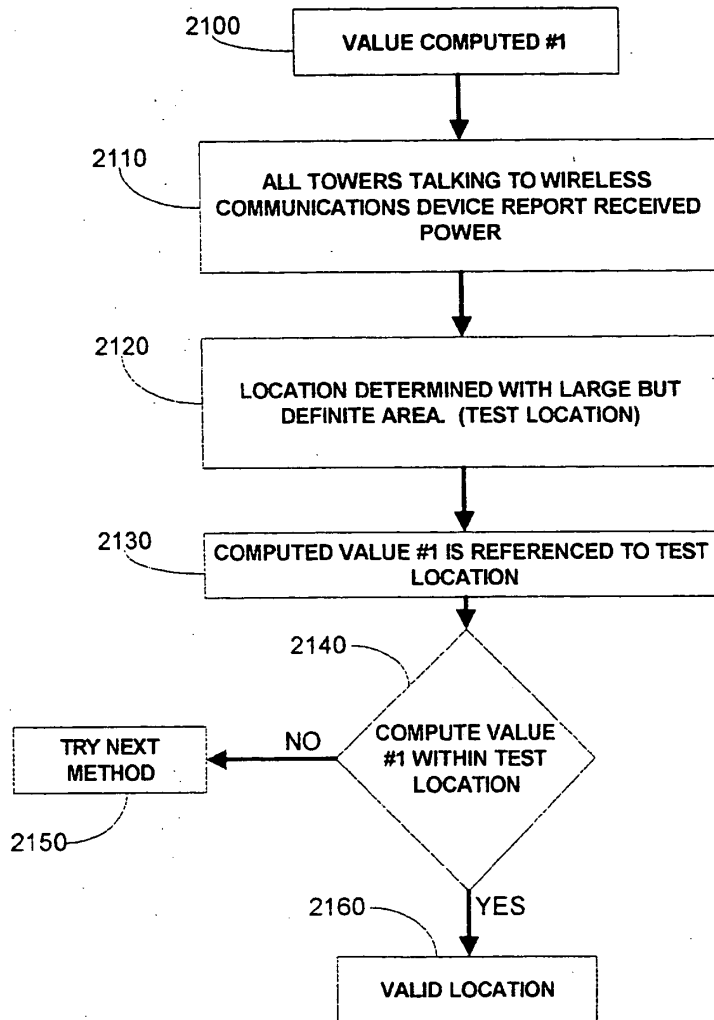

### E-MOBILITY USER LOCATION DATABASE QUERIES

FIG. 22

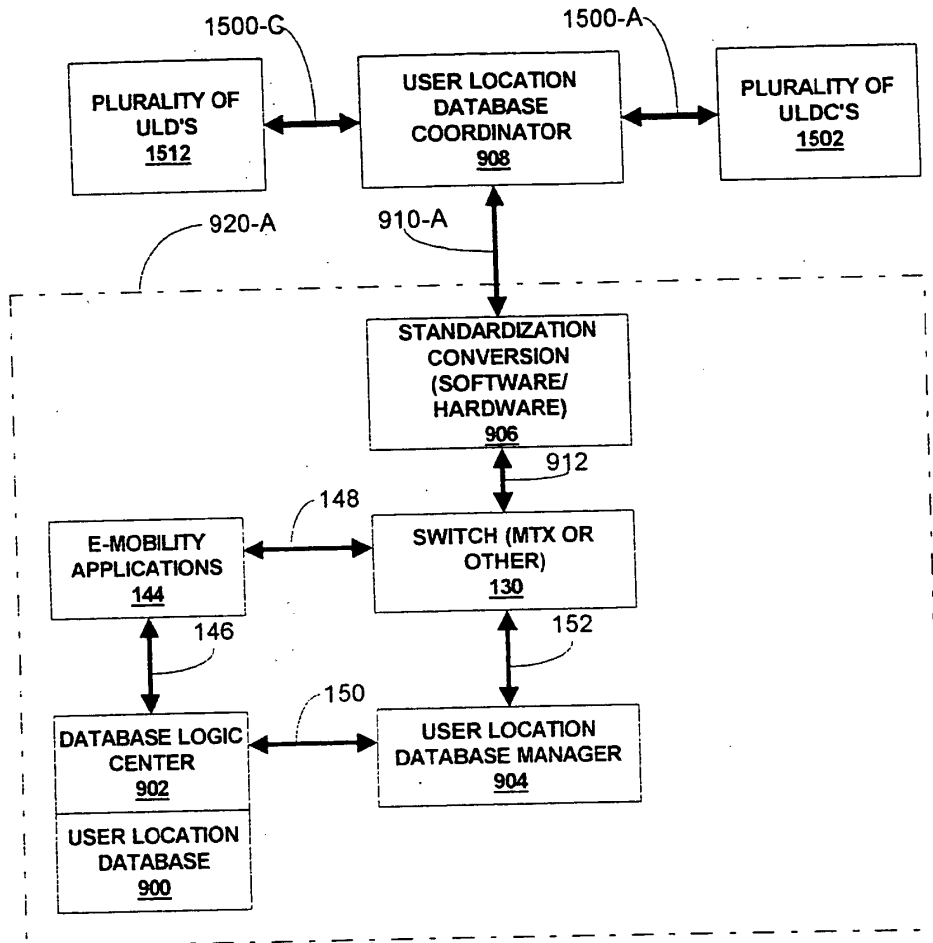

### RF REMOTE LINK COMPONENTS

FIG. 23

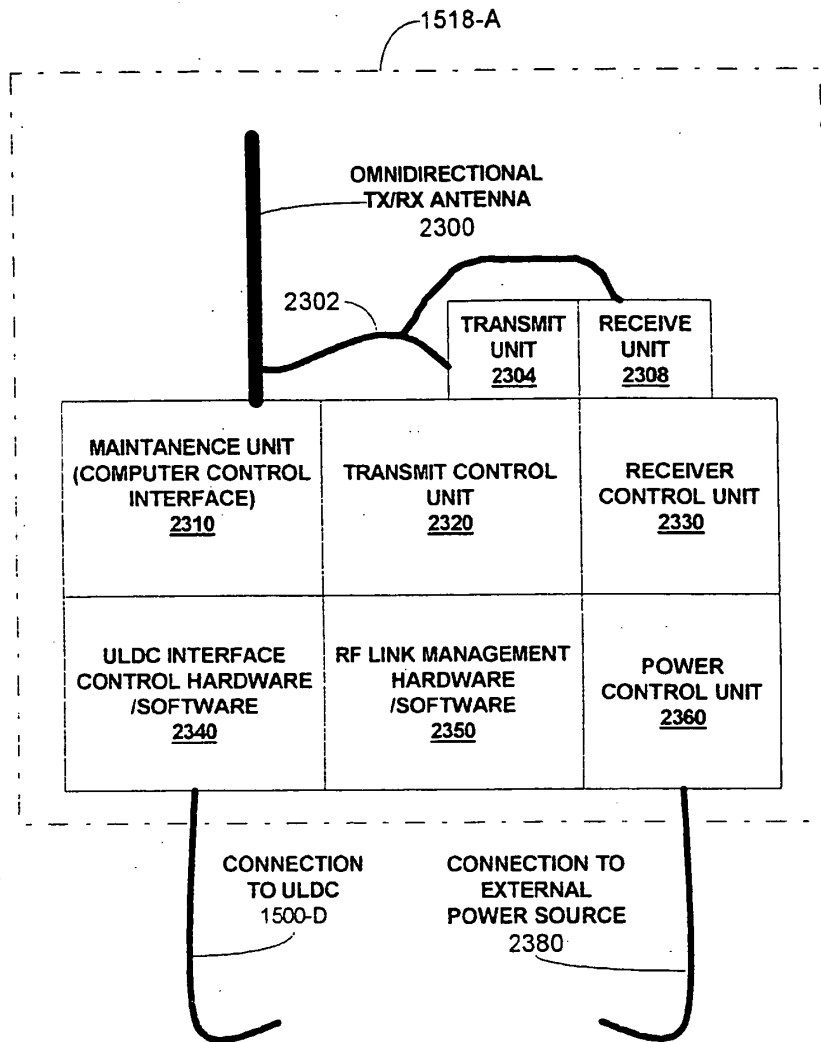

### RF REMOTE LINK TO REMOTE MOBILE DEVICE

FIG. 24

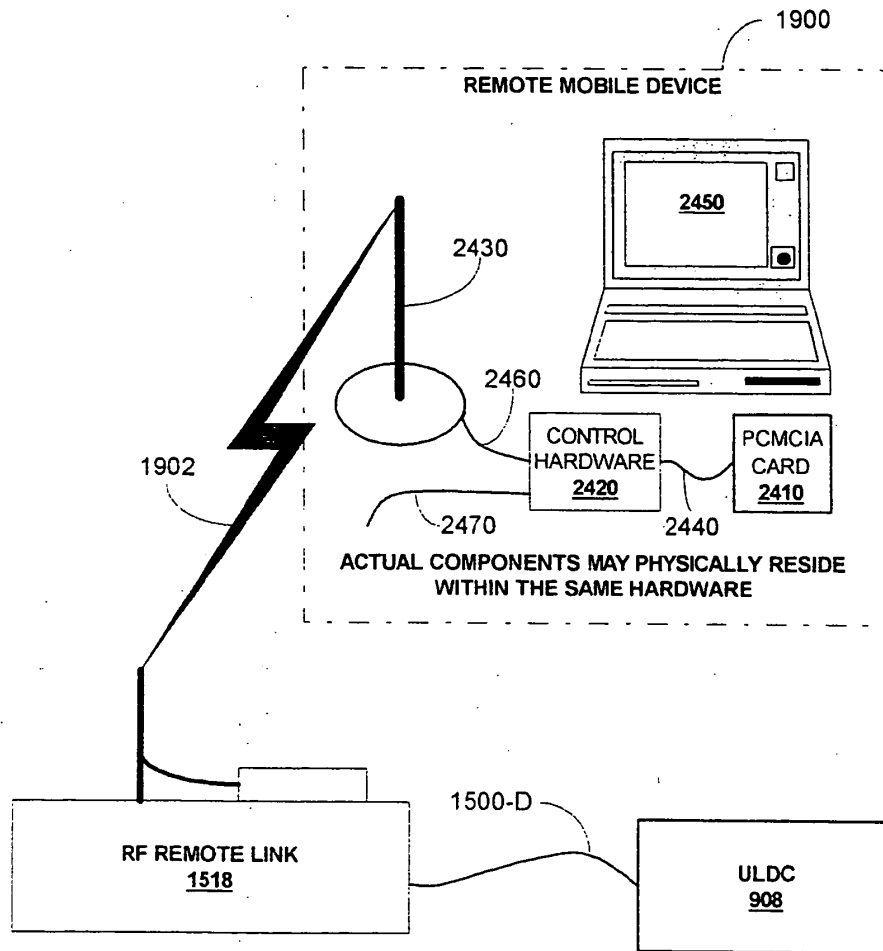

**RF REMOTE LINK NETWORK**

**FIG. 25**

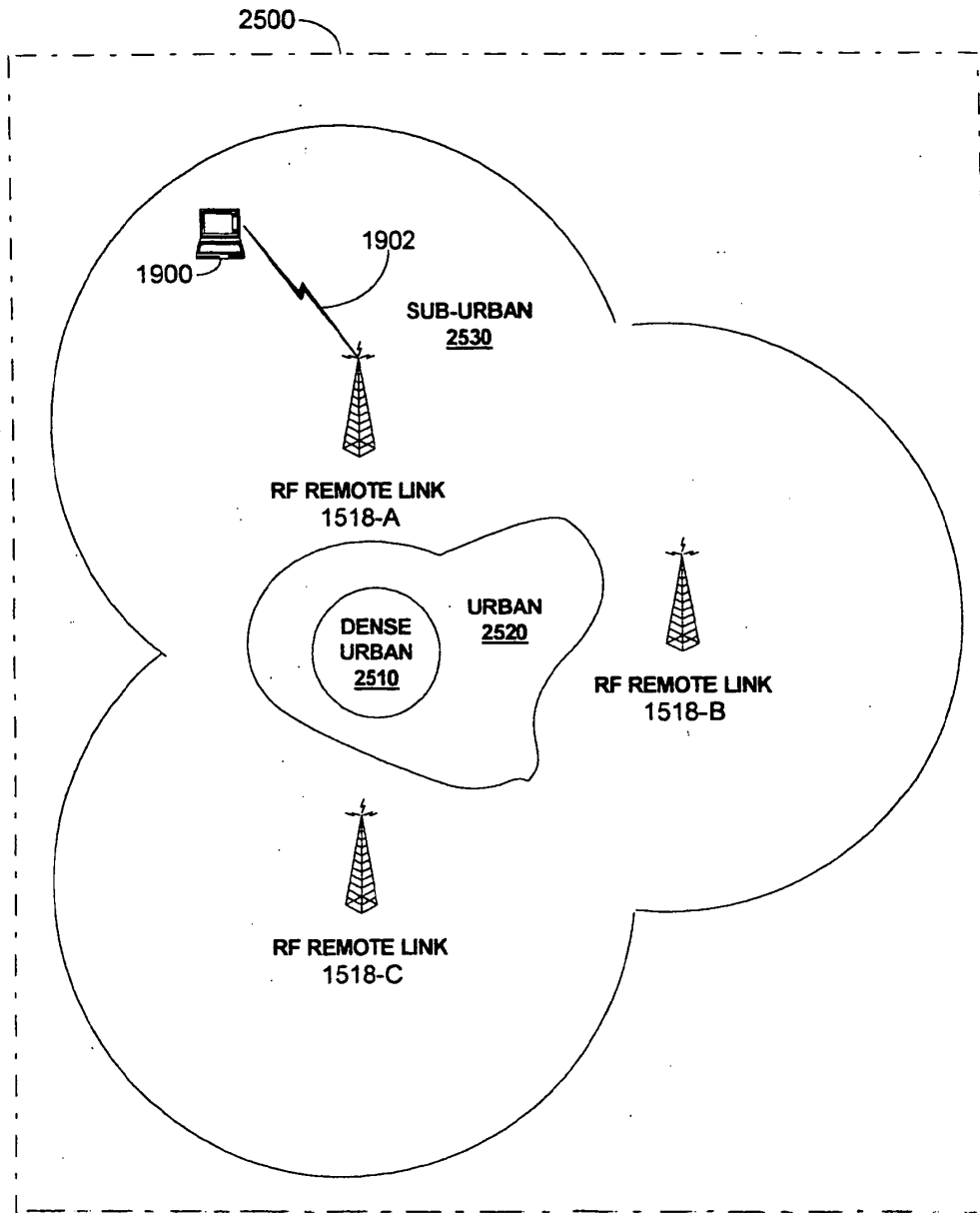

### REMOTE MOBILE DEVICE CONTROL HARDWARE

FIG. 26

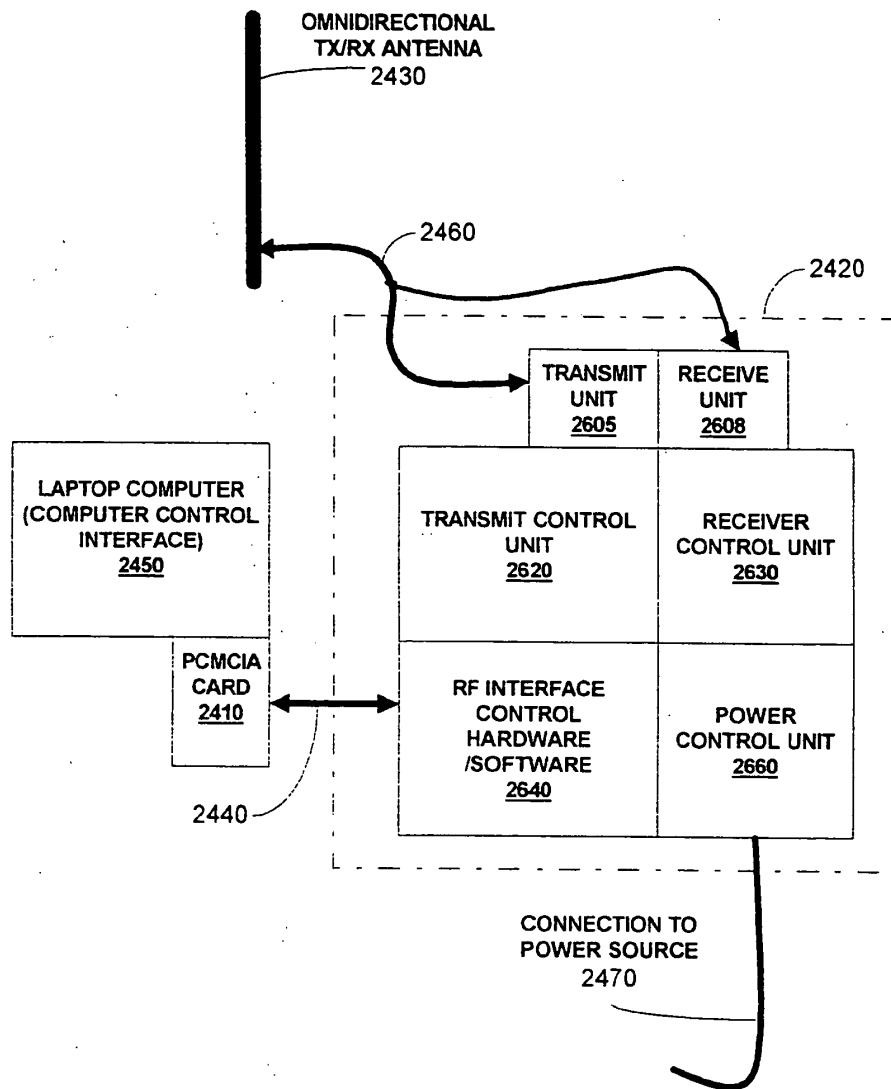



FIG. 27

## COMPONENTS UTILIZED BY ULDM WHEN LOCATING WIRELESS DEVICE

	MTX	HLR	VLR	ULD	BSCSBS	SHELFS	BTS	WIRELESS DEVICE
METHOD 1	X	X	X	X	X	X	X	
METHOD 2	X	X	X	X	X	X		
METHOD 3	X	X	X	X	X	X		
METHOD 4	X	X	X	X				X

METHOD 1: DIGITAL SIGNATURE

METHOD 2: TRIANGULATION AND SIGNAL STRENGTH

METHOD 3: SIGNAL STRENGTH ONLY

METHOD 4: ALTERNATIVE EMBODIMENT; LOCATION DETERMINED AT WIRELESS DEVICE (GPS, TRIANGULATION, ETC.)

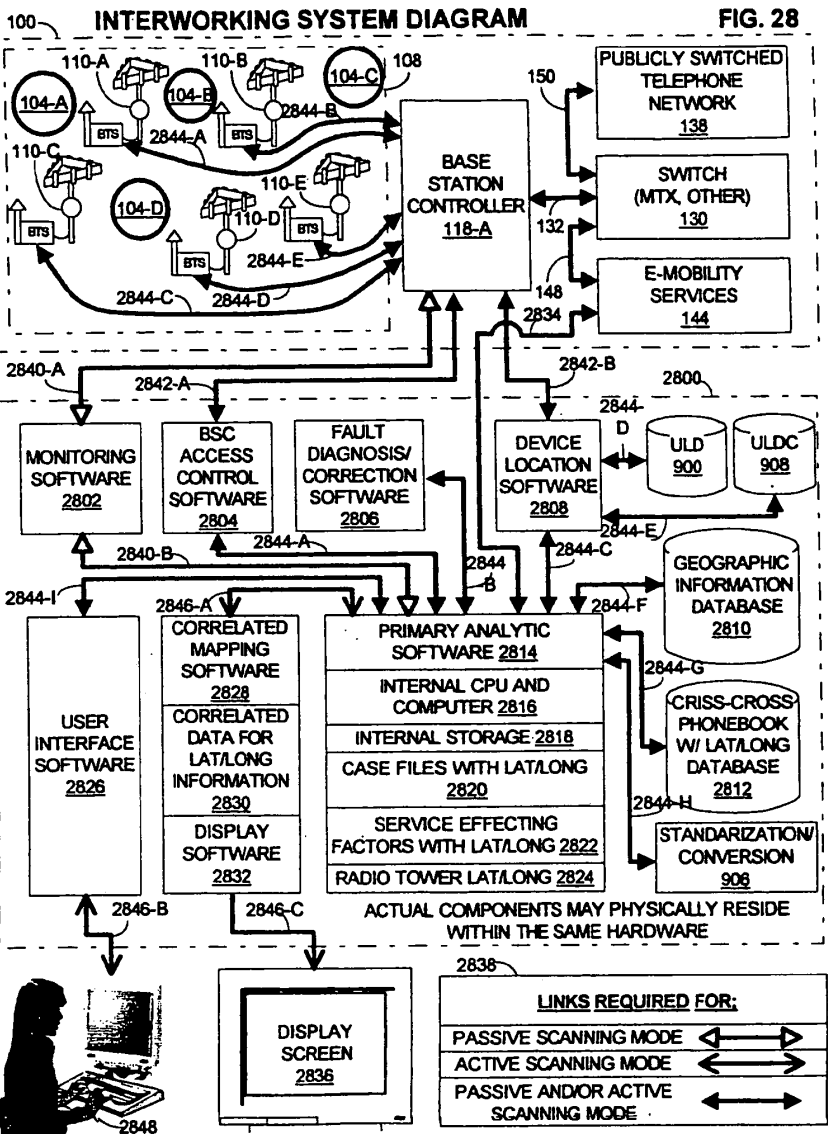

**PHYSICAL REALIZATION OF PREFERRED EMBODIMENTS**

**FIG. 29**

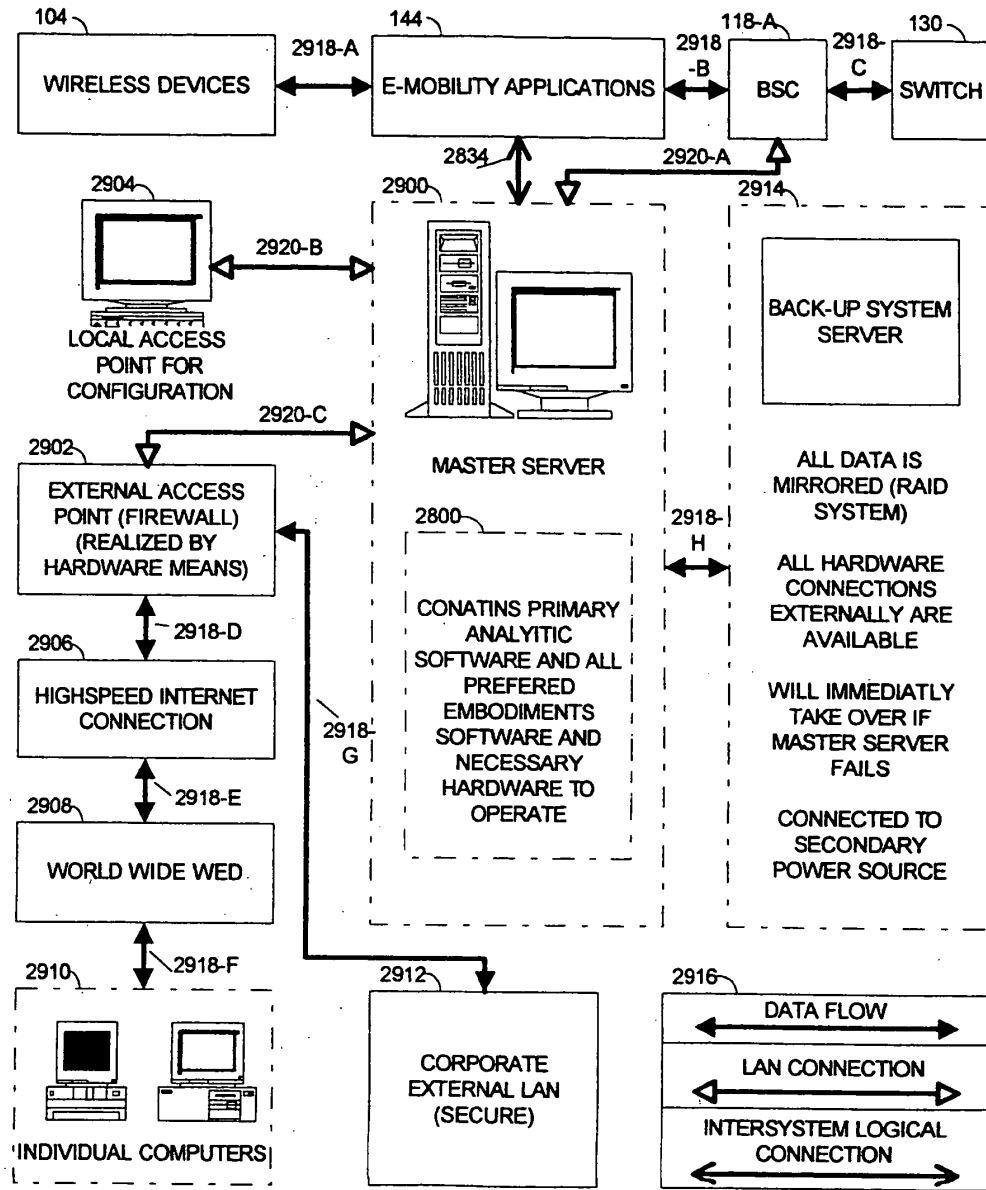

906 STANDARDIAZTION/CONVERSION SOFTWARE FIG. 30

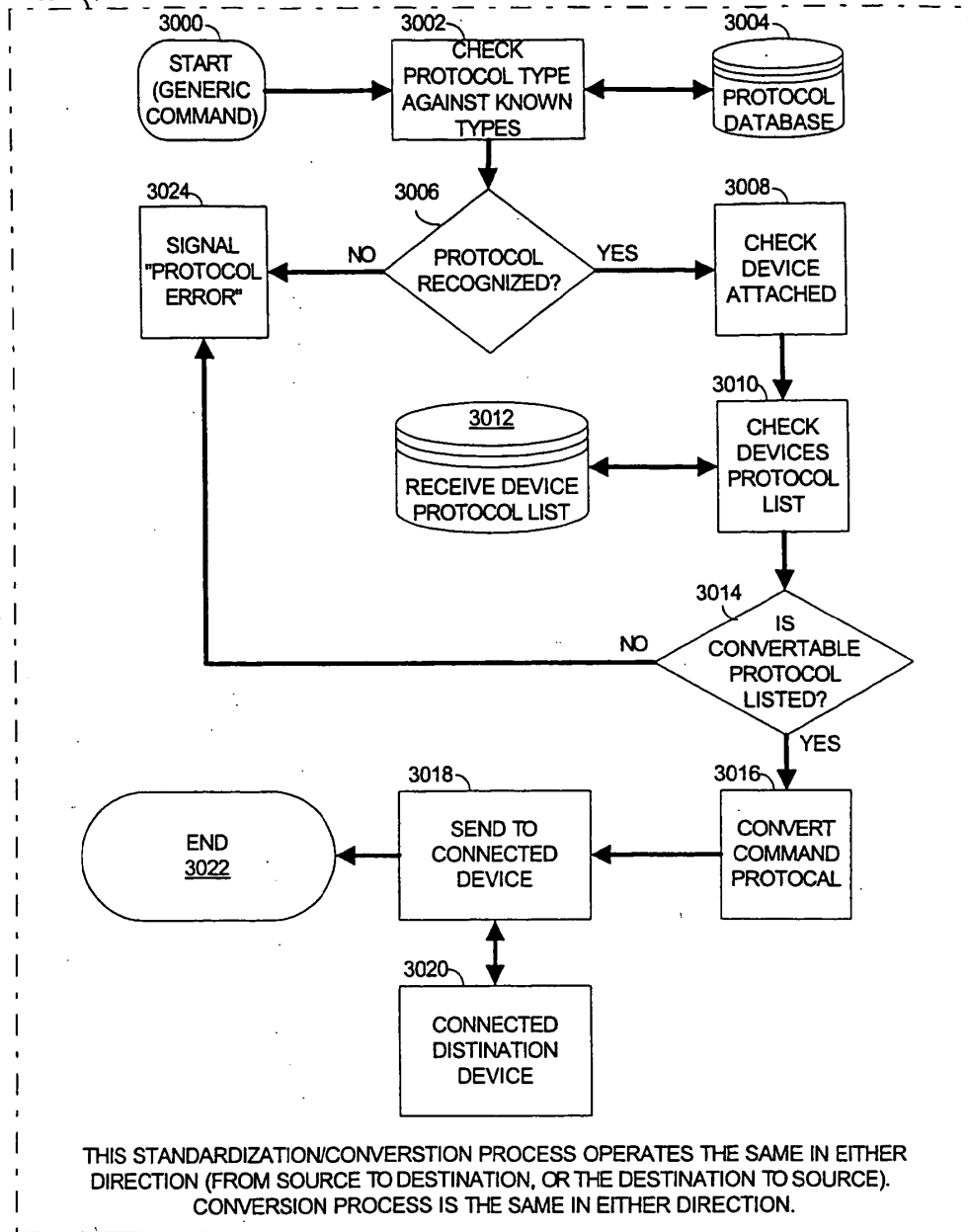

### BSC ACCESS CONTROL SOFTWARE

FIG. 31

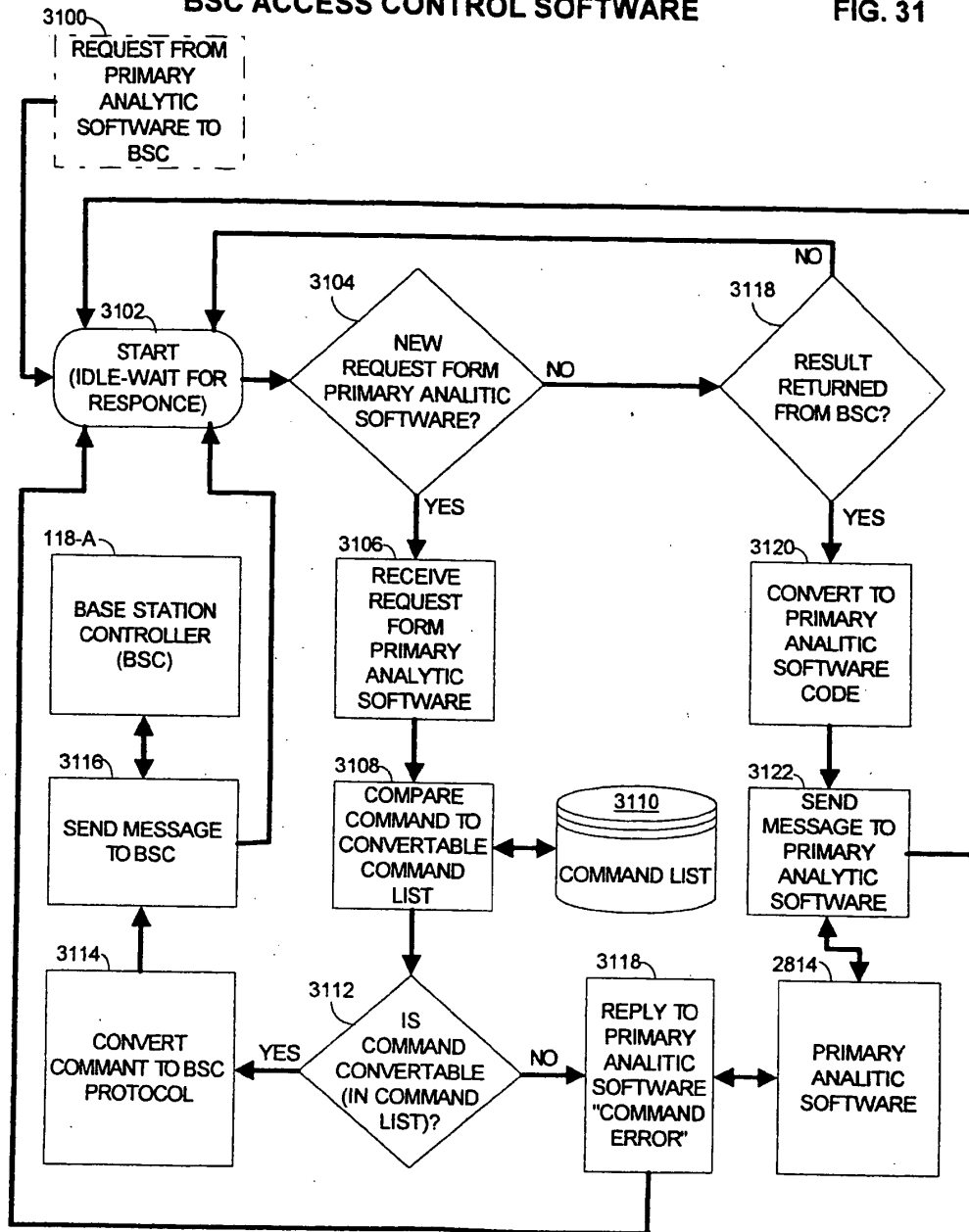

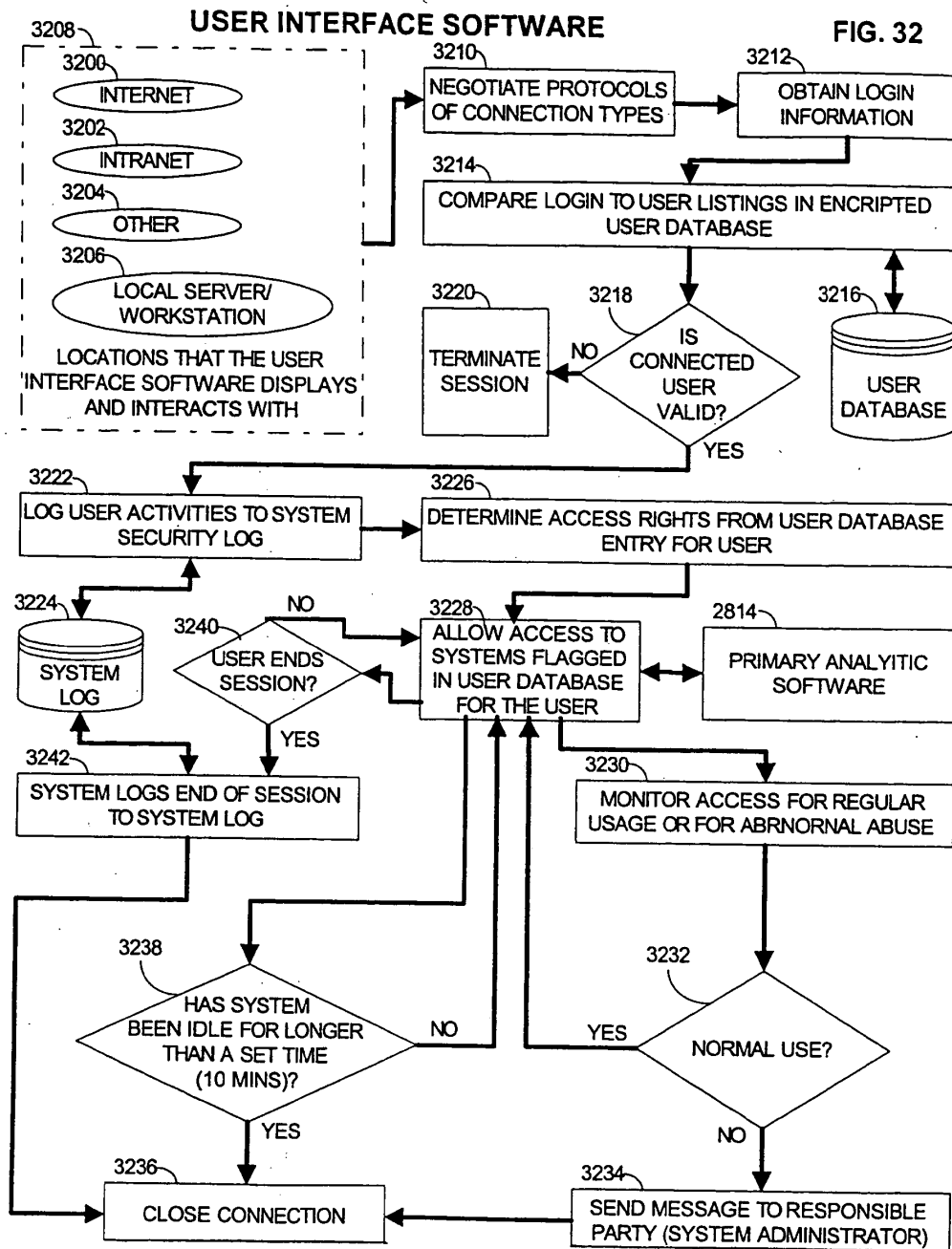

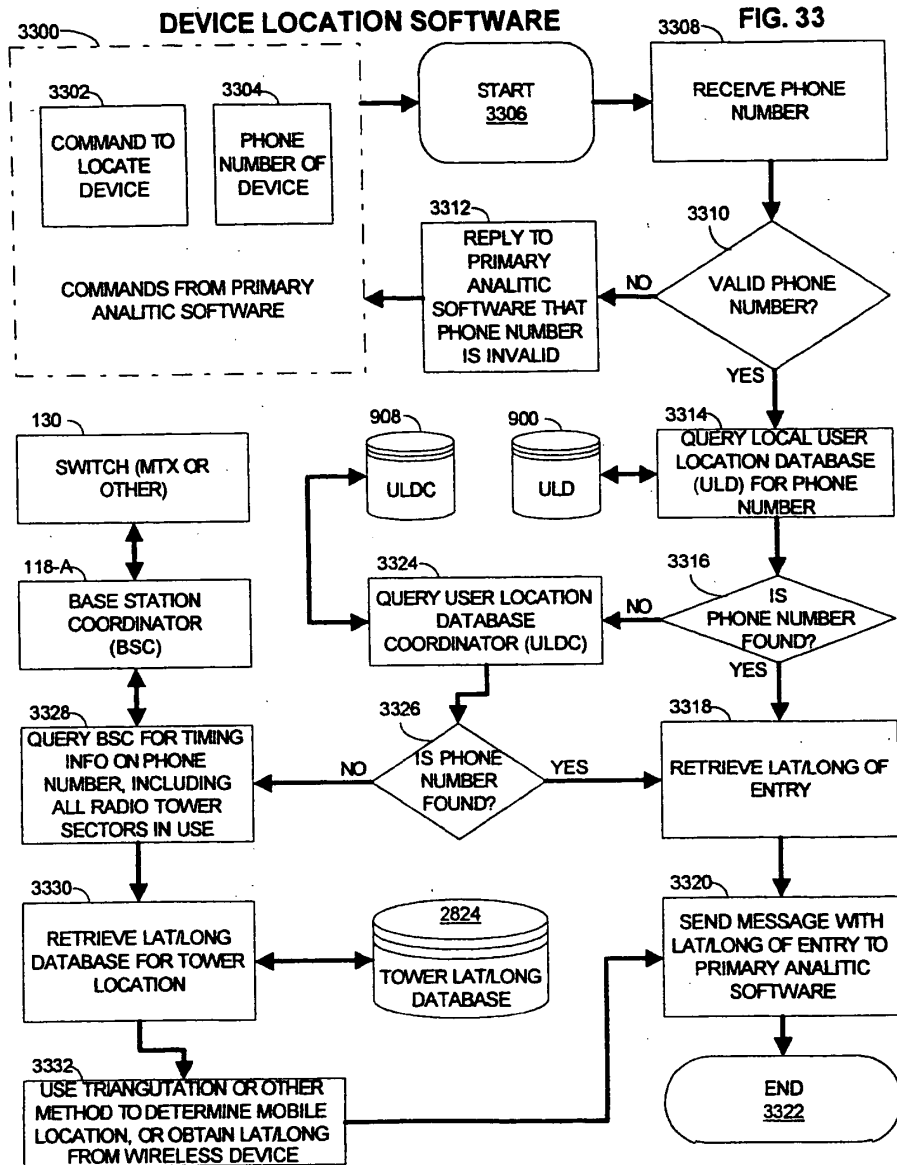

### TARGETING DEVICES TO TRACK

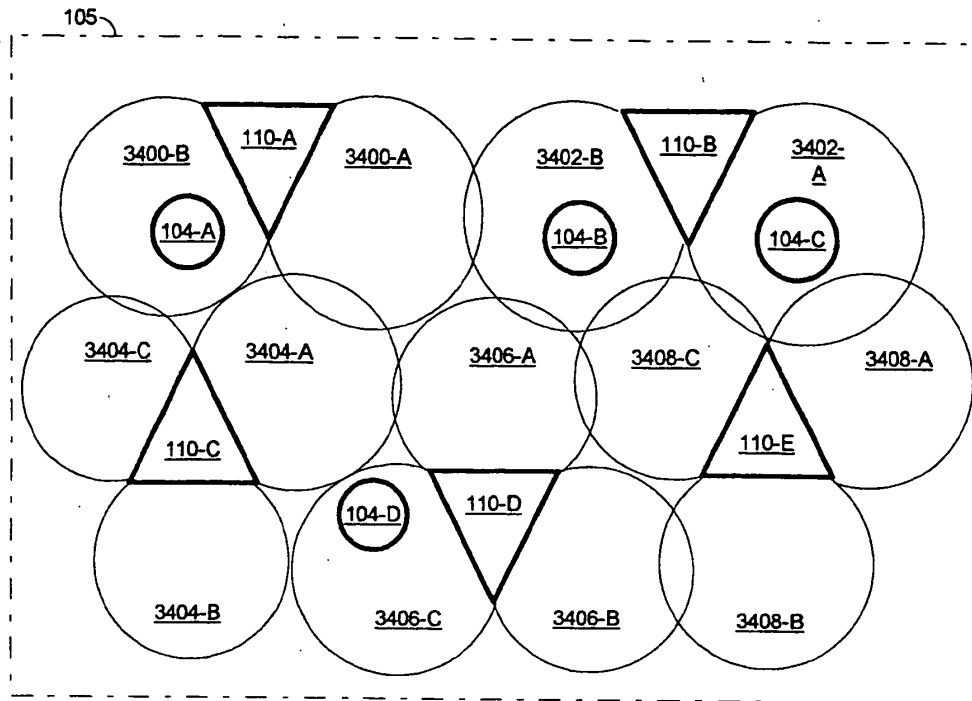
**FIG. 34**

REQUEST>BTS SECTOR 3400-B  
 RETURN<MOBILE #104-A+ ALL WIRELESS DEVICES THAT ENTER SECTOR WHILE TRACKING.

REQUEST>BTS SECTOR 3402-A  
 RETURN<MOBILE #104-C+ ALL WIRELESS DEVICES THAT ENTER SECTOR WHILE TRACKING.

REQUEST>BTS SECTOR 3400-B, 3402-A, 3402-B  
 RREQUEST>BTS SECTOR , 3400-B, RETURN +<MOBILE #104-A+ ALL WIRELESS DEVICES THAT ENTER SECTOR WHILE TRACKING.

REQUEST>INDIVIDUAL OR PLURALITY OF WIRELESS DEVICES  
 RETURN<ALL MOBILES QUERIED ABOVE.



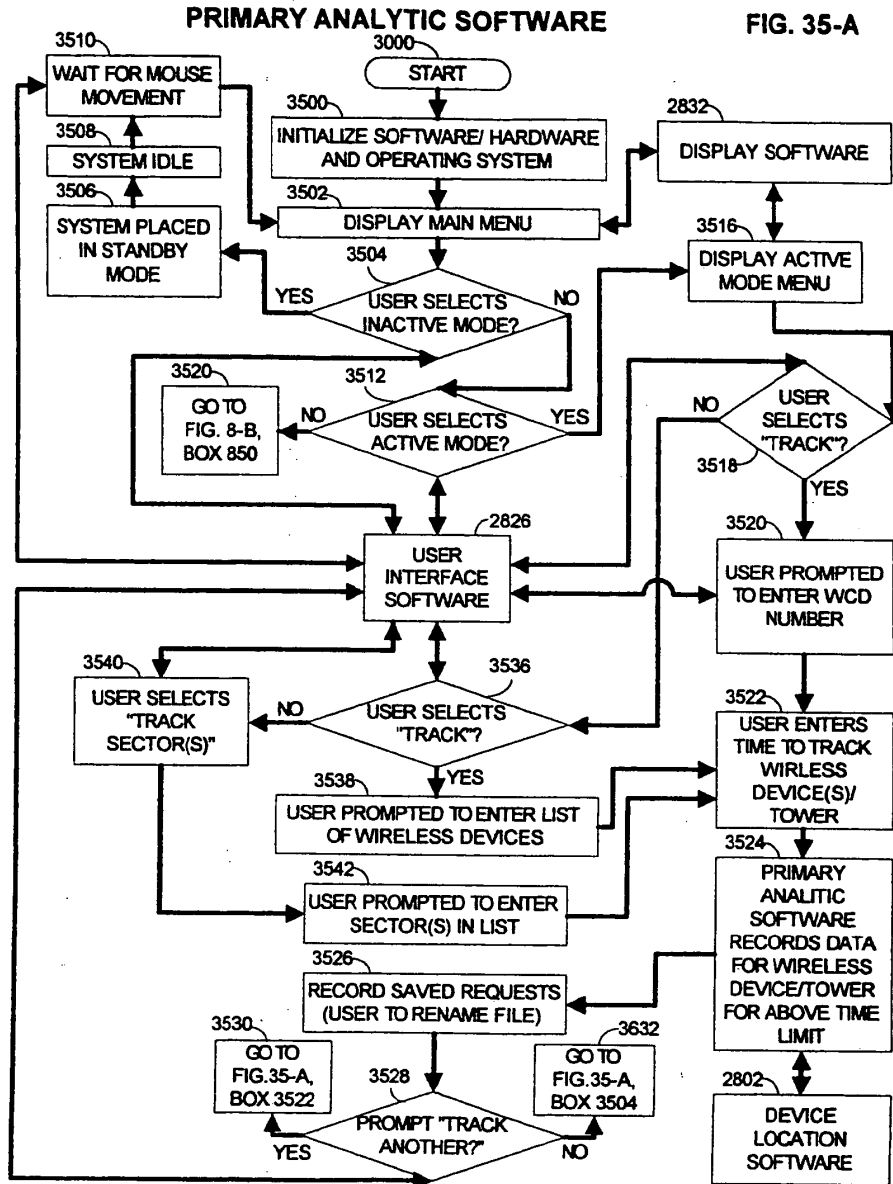

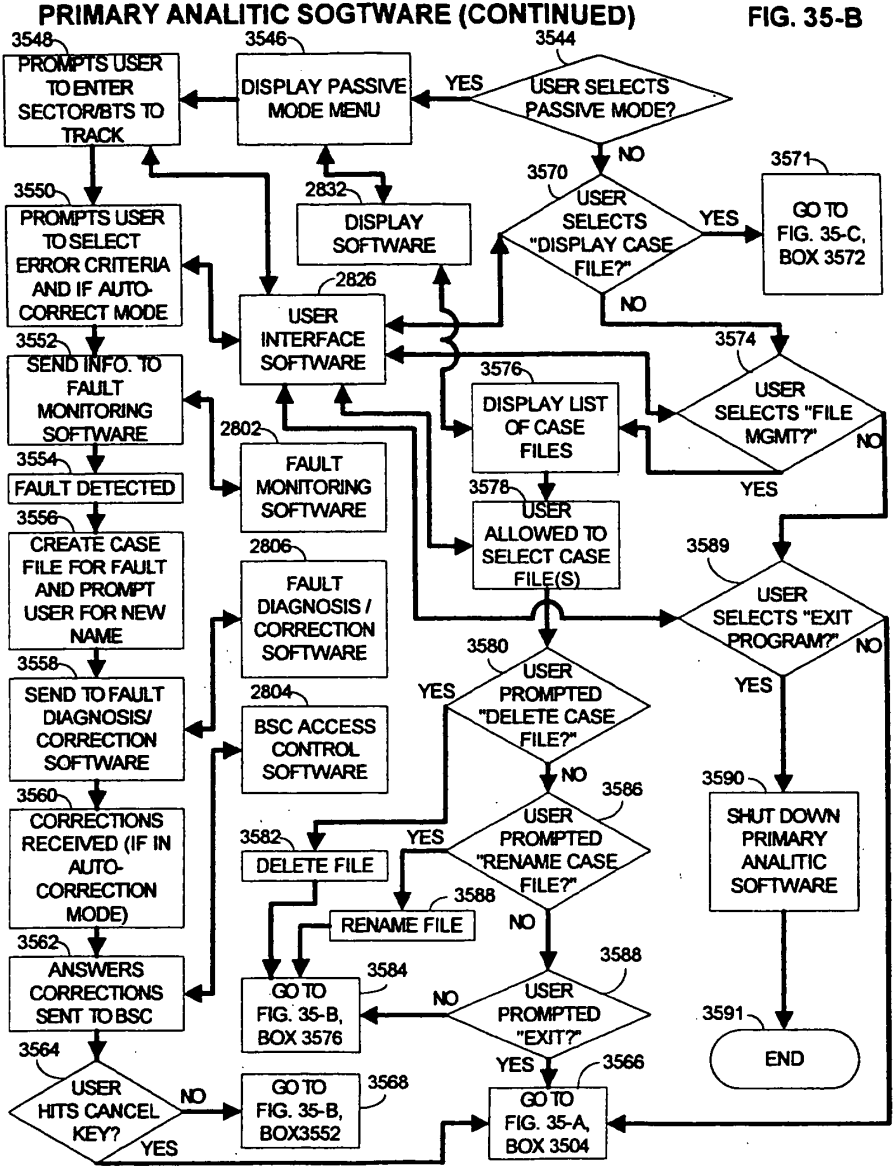

PRIMARY ANALYTIC SOFTWARE (CONTINUED)

FIG. 35-C

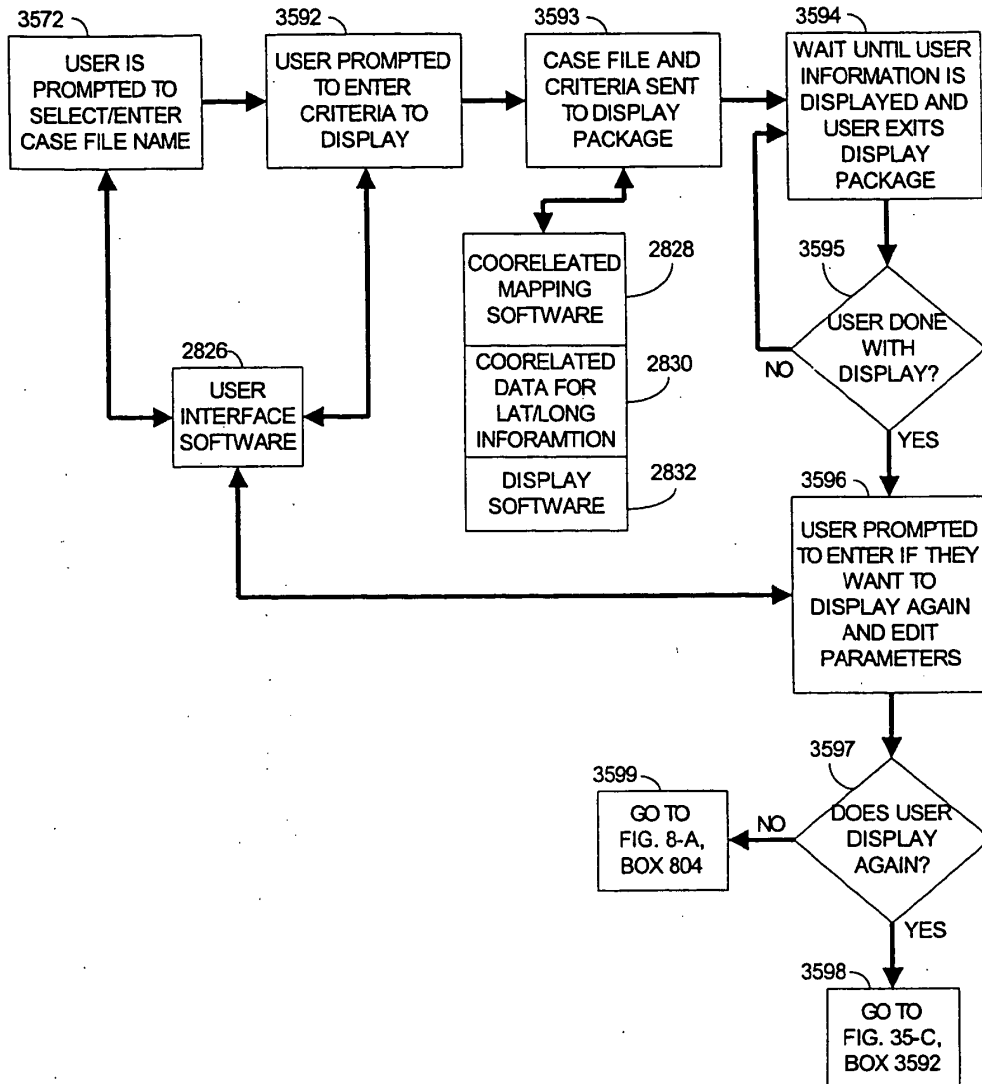

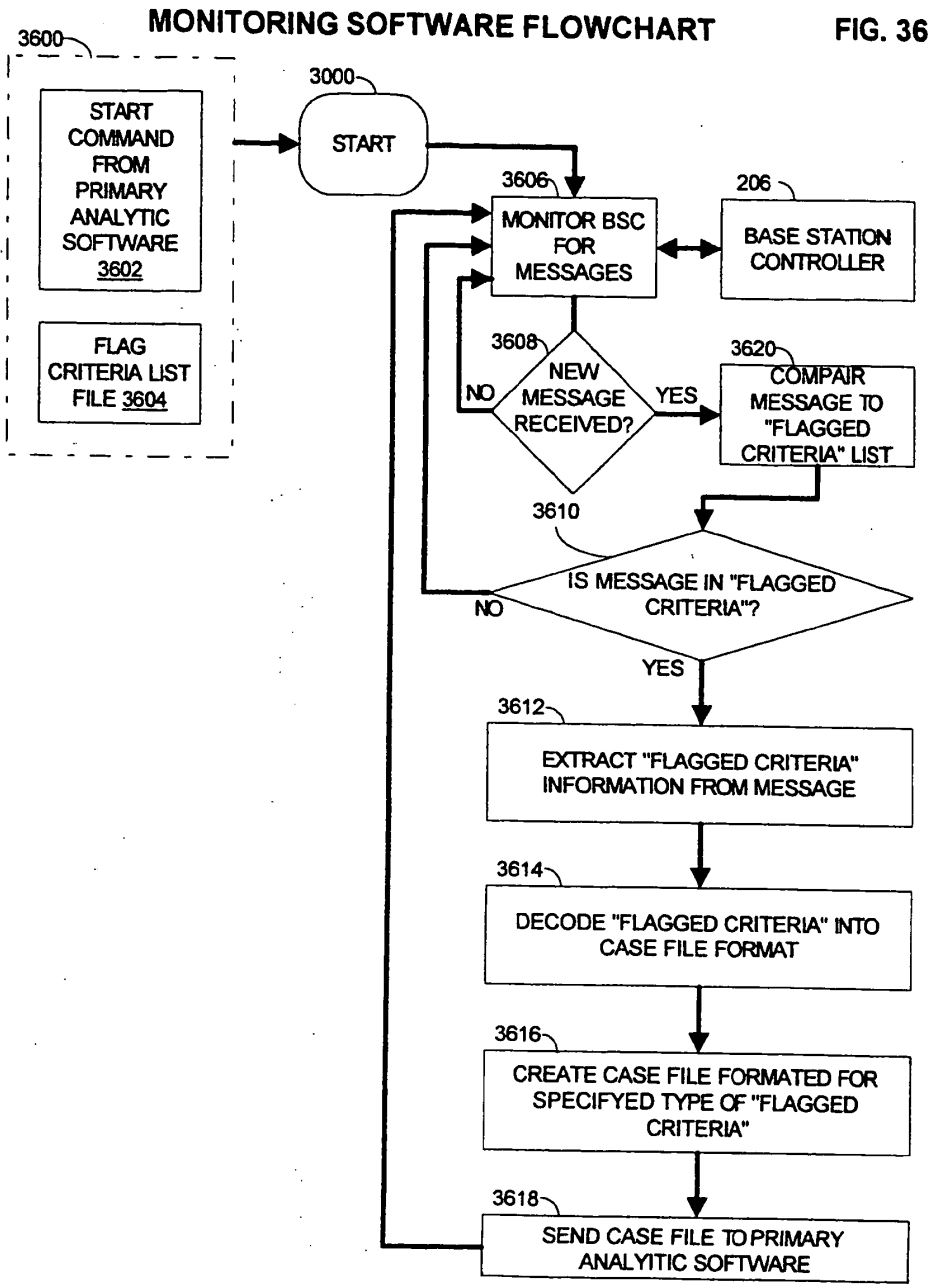

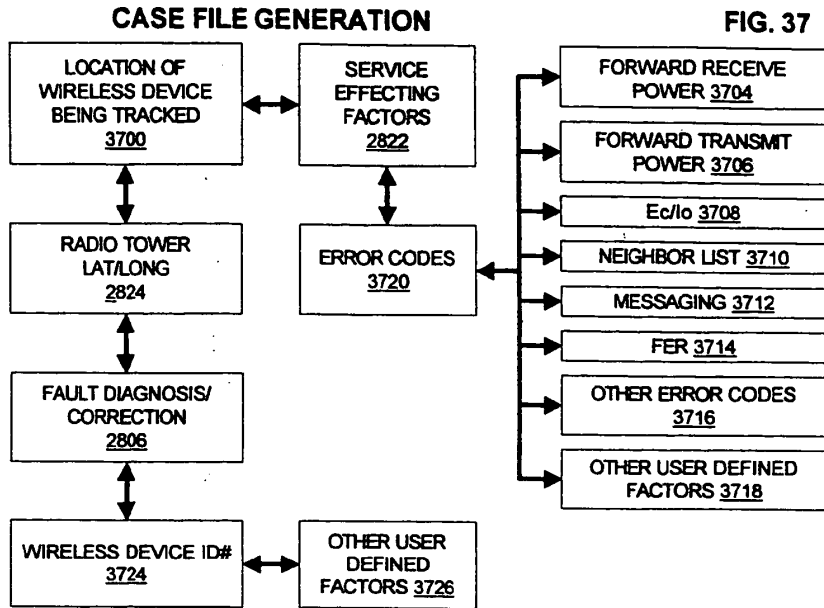

2820

CASE FILE # 3722	INDIVIDUAL WIRELESS DEVICE LOCATION 3700	ERROR CODE 3720	WIRELESS DEVICE ID # 3724	SERVICE EFFECTING FACTORS 2822	RADIO TOWER LAT/LONG 2824	FAULT DIAGNOSIS/CORRECTION 2806	OTHER USER FACTORS 3726
"	"	"	"	"	"	"	"
"	"	"	"	"	"	"	"
"	"	"	"	"	"	"	"
"	"	"	"	"	"	"	"
"	"N" NUMBER OF WIRELESS DEVICES 3728	"	"	"	"	"	"

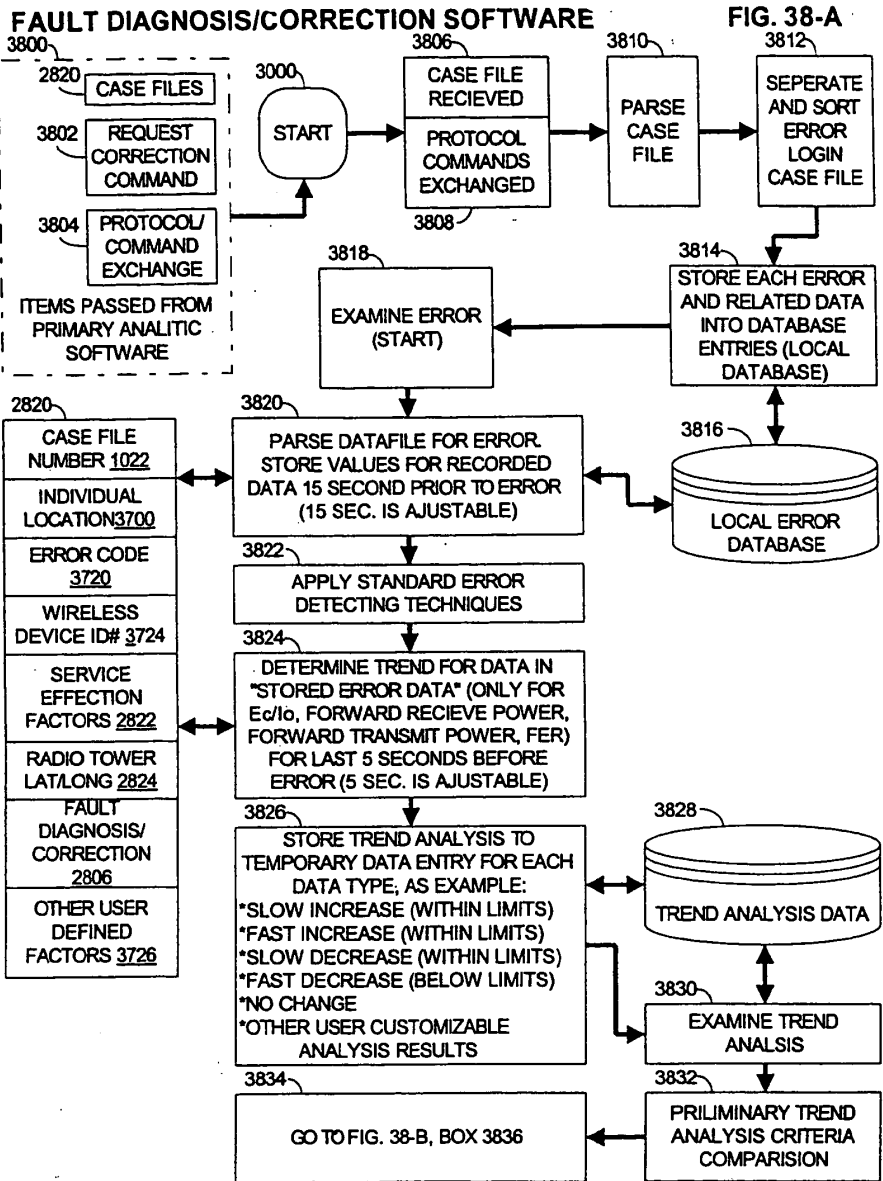

FAULT DIAGNOSIS/CORRECTION SOFTWARE

FIG. 38-B

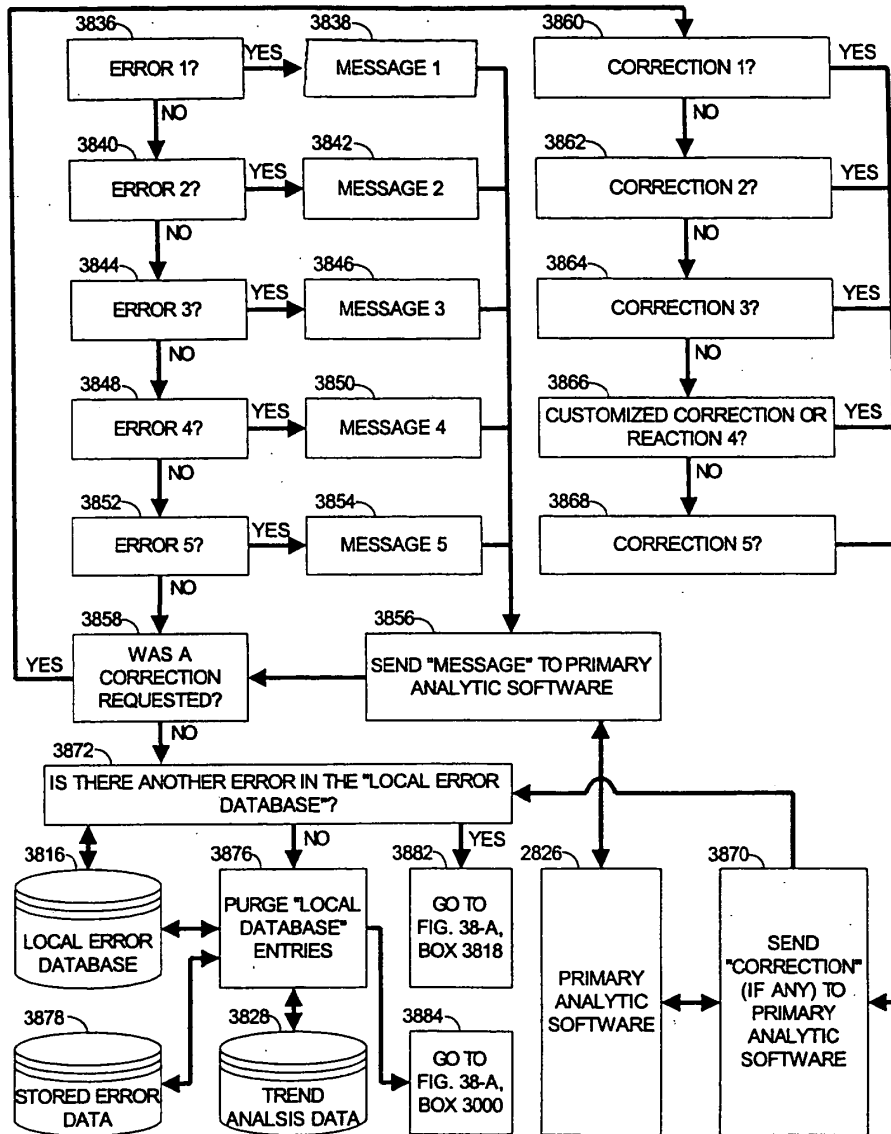

**FAULT DIAGNOSIS/CORRECTION SOFTWARE****FIG. 38-C**

3878

#	ERROR TABLE
1	FER=FAST INCREASE FORWARD RECEIVE POWER=INCREASE? (TOWER RECEIVE STRENGTH)
2	FORWARD RECEIVE POWER=FAST DECREASE FER=FAST INCREASE?
3	$E_c/I_o$ =FAST INCREASE FER=SLOW OR FAST INCREASE?
4	OTHER COMPARISON CRITERIA (USER CUSTOMIZABLE) WITH USER CONCLUSION MESSAGES (CAN EXAMINE ANY DATA IN ERROR DATABASE)?
5	SEND CONCLUSION MESSAGE "UNABLE TO AUTO DETECT ERROR"

3886

#	MESSAGE TABLE
1	"MOBILE CROSS-TALK INTERFERENCE TOO HIGH"
2	"MOBILE OUT OF RANGE OF TOWER"
3	"PN POLLUTION TOO HIGH FOR MOBILE"
4	USER CUSTOMIZABLE MESSAGE FOR CUSTOMIZED ANALYSIS
5	"UNABLE TO DETECT ERROR"

3888

#	CORRECTION TABLE
1	NONE
2	INCREASE TOWER FORWARD TRANSMIT POWER
3	DECREASE FORWARD TRANSMIT POWER ON PN'S IN MOBILE RECEIVE AREA WITH TOWERS GREATER THAN 5KM AWAY
4	SEND CUSTOMIZED CONFIGURATION CHANGE BACK TO PRIMARY ANALYTIC SOFTWARE
5	SEND NO CONFIGURATION CHANGE BACK



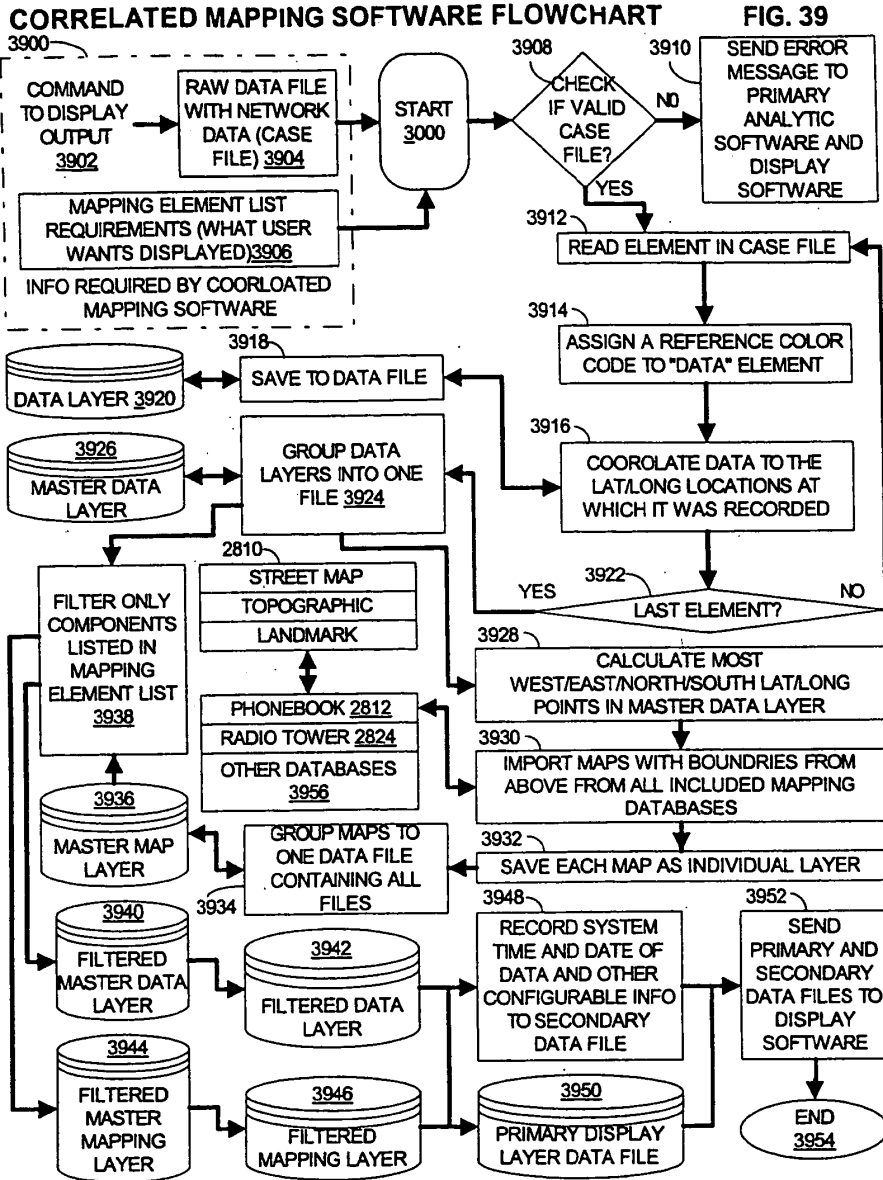

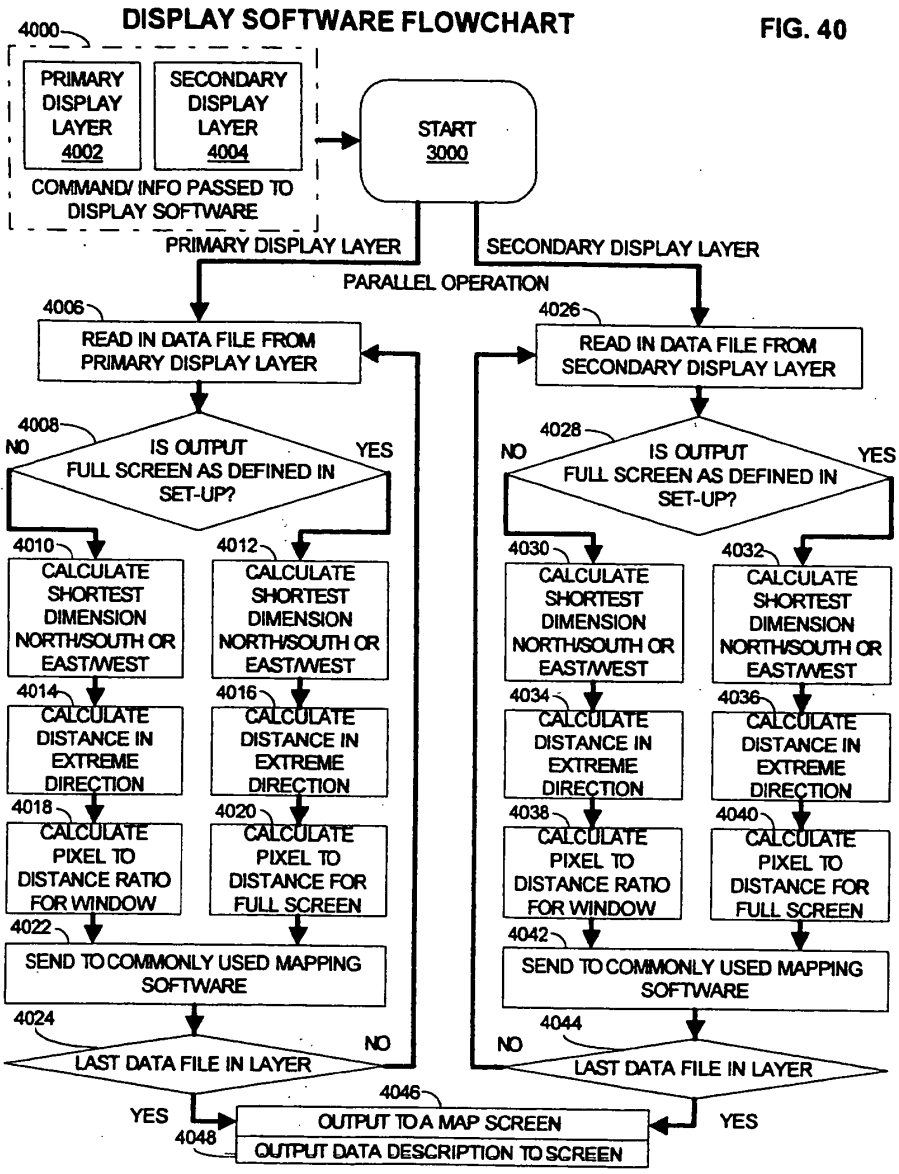

FINAL DISPLAY OUTPUT

FIG. 41

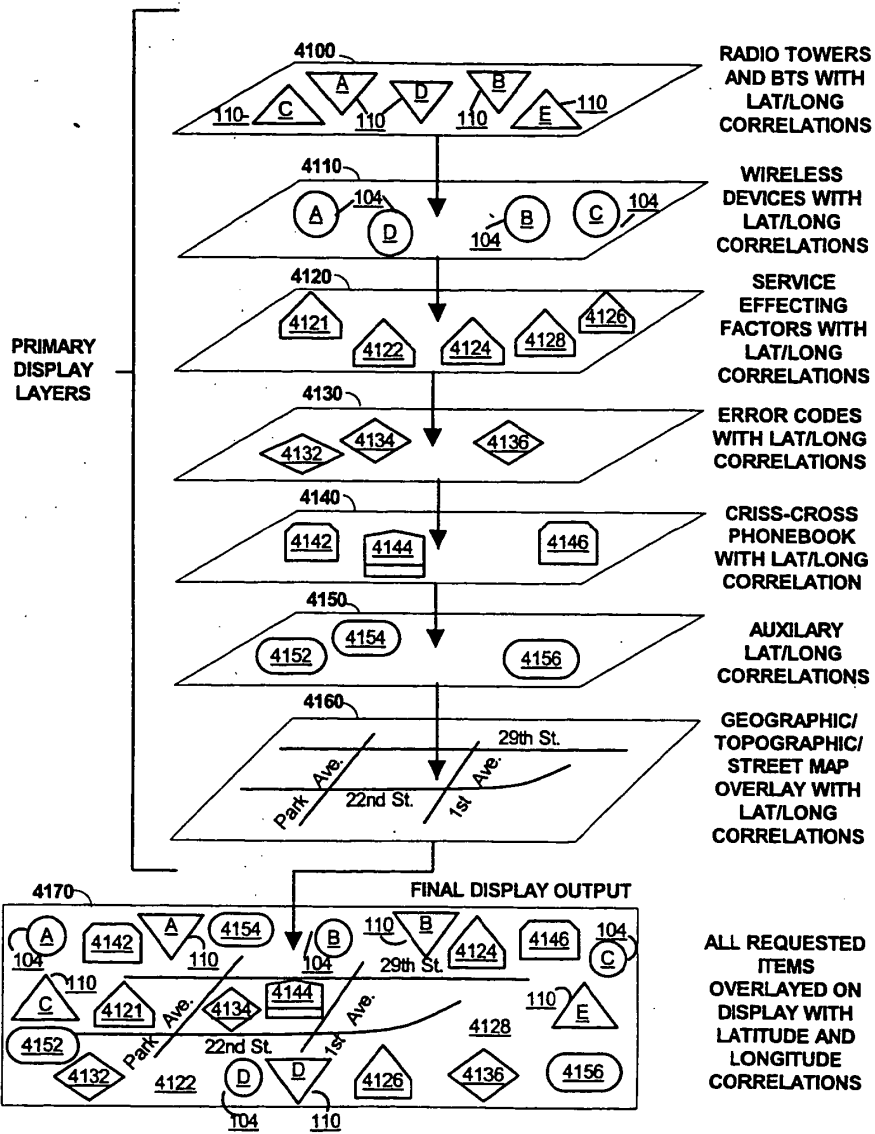

PRO-ACTIVE NETWORK TUNING SOFTWARE

FIG. 42

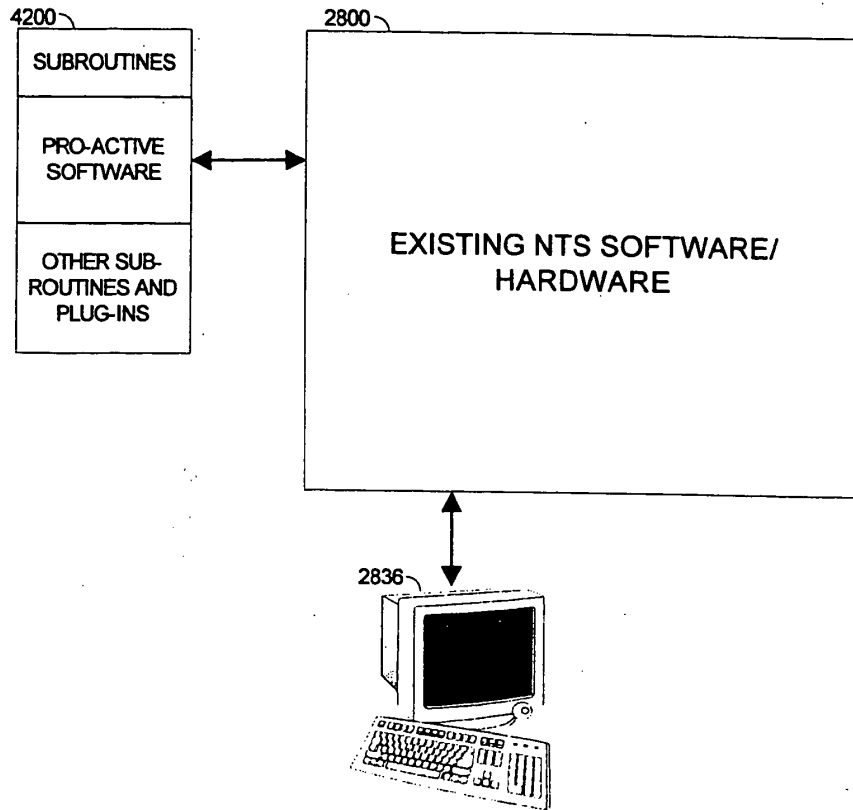

**ACTIVE WIRELESS UNIT DENSITY GEOGRAPHIC ZONING**

**FIG. 43**

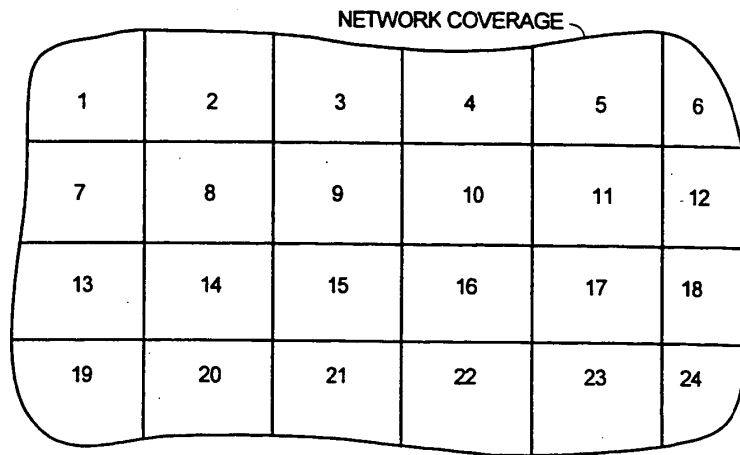

### ACTIVE WIRELESS UNIT DENSITY

FIG. 44

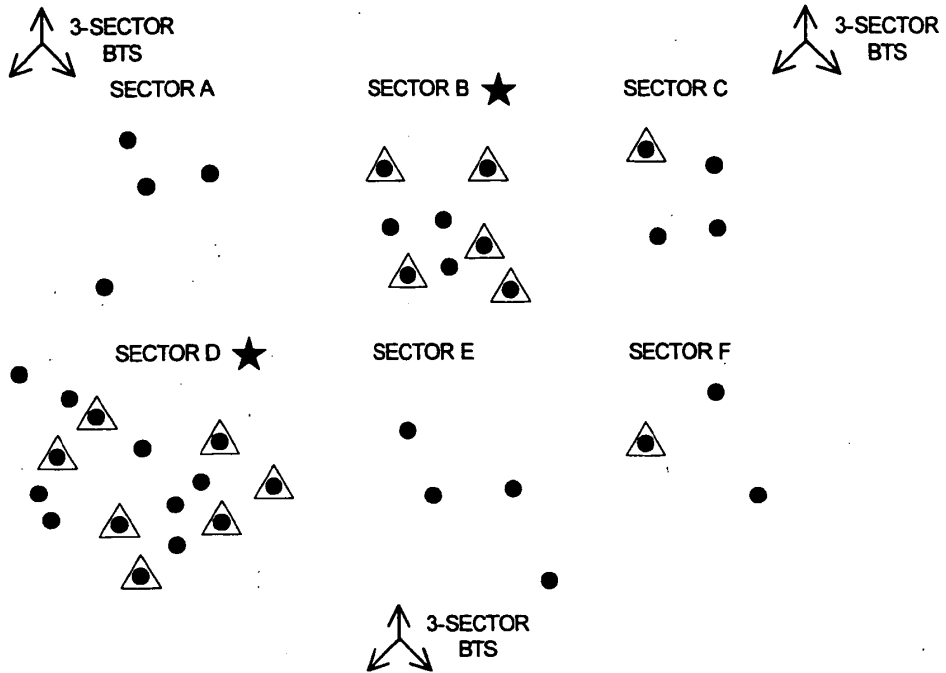

- - WIRELESS UNIT COMMUNICATING TO NETWORK WITH BER/FER LESS THAN 2-20%
- ▲ - WIRELESS UNIT COMMUNICATING TO NETWORK WITH BER/FER GREATER THAN 2-20%
- ★ - SECTOR HAS GREATER THAN 50% OF MOBILES WITH BER/FER OVER 20%

**TERRAIN INTERFERENCE NON-RADIAL ZONING**

**FIG. 45**

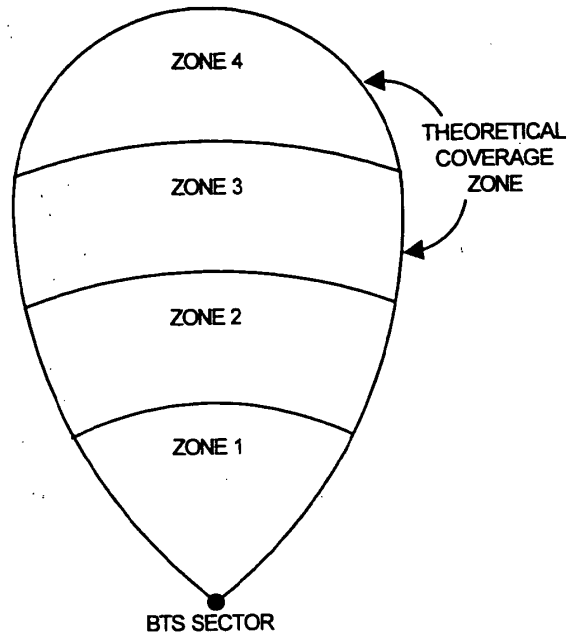

TERRAIN INTEFERENCE RADIAL DIVIDED ZONING FIG. 46

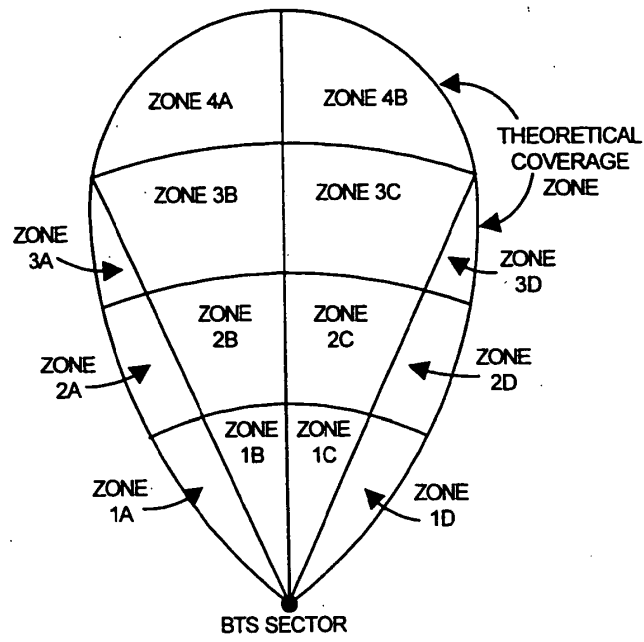



**TERRAIN INTEFERENCE RADIAL DIVIDED BORDER ZONES**

**FIG. 47**

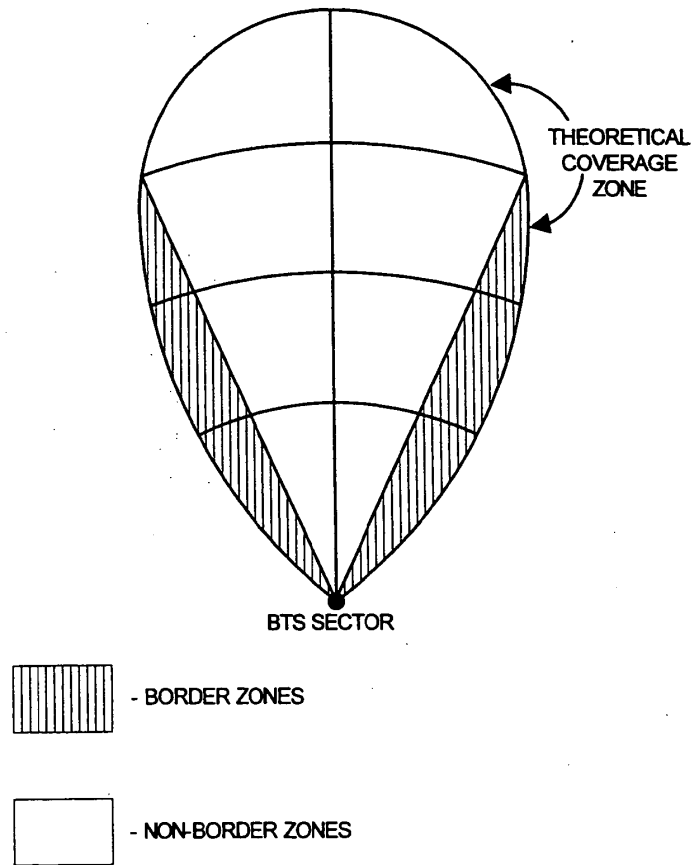

THERMAL PROCESS FLOWCHART

FIG. 48

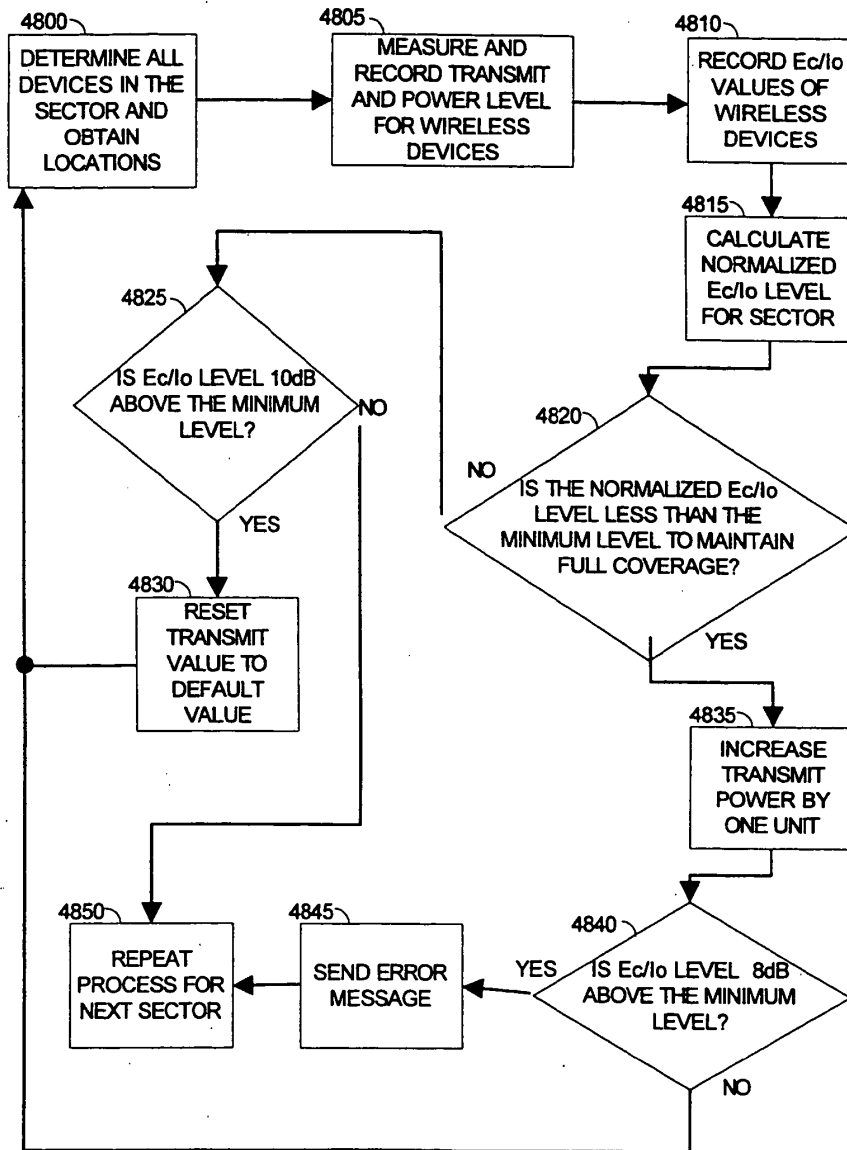

ACTIVE WIRELESS UNIT DENSITY PROCESS

FIG. 49

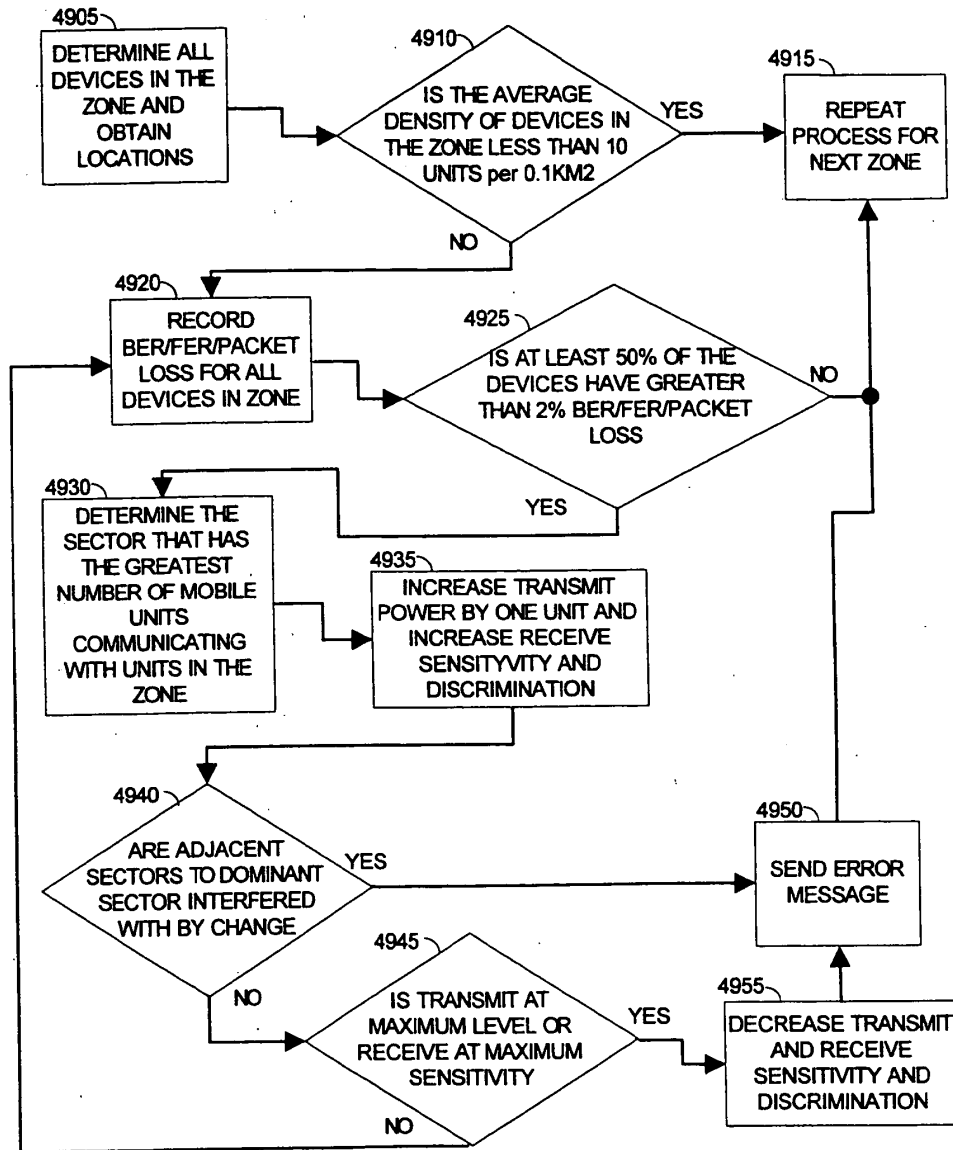

TERRAIN TUNING PROCESS

FIG. 50

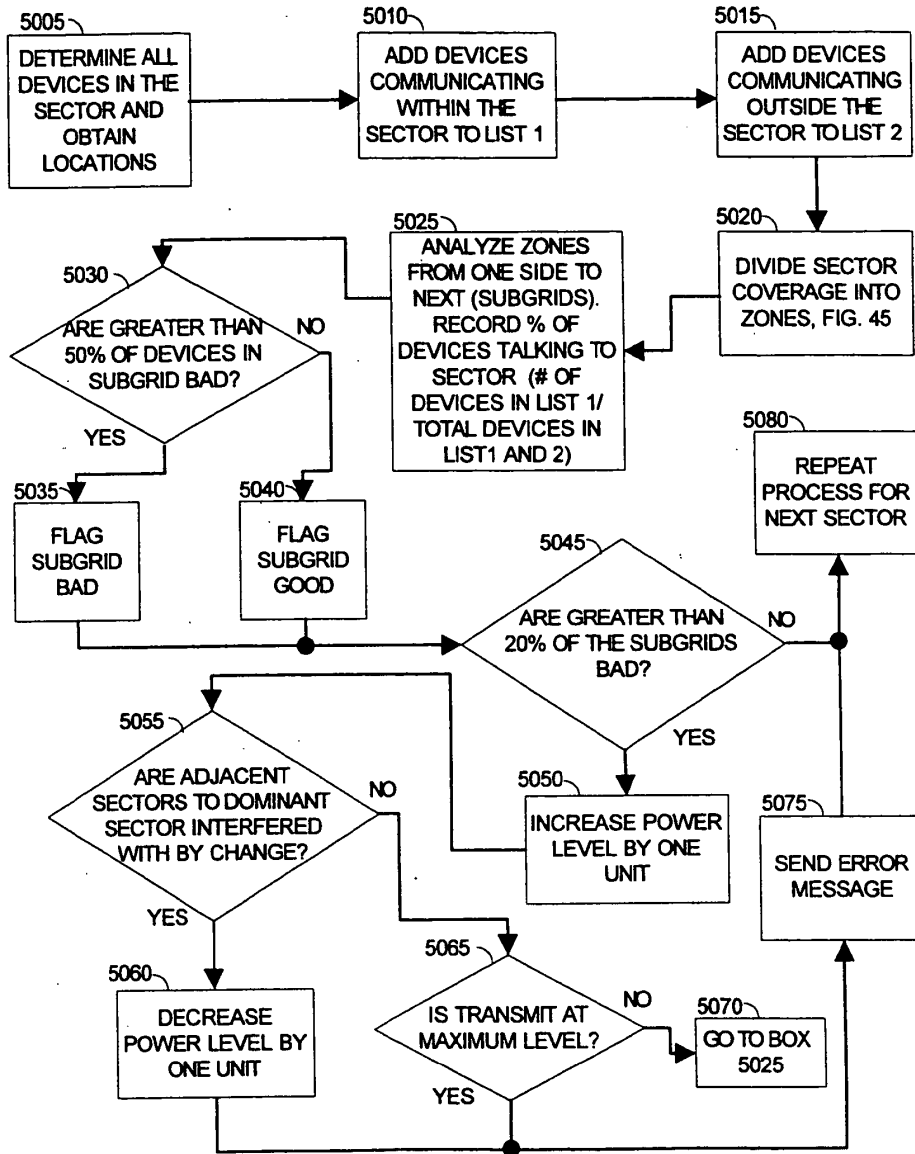

NETWORK EQUIPMENT TUNING FLOWCHART

FIG. 51

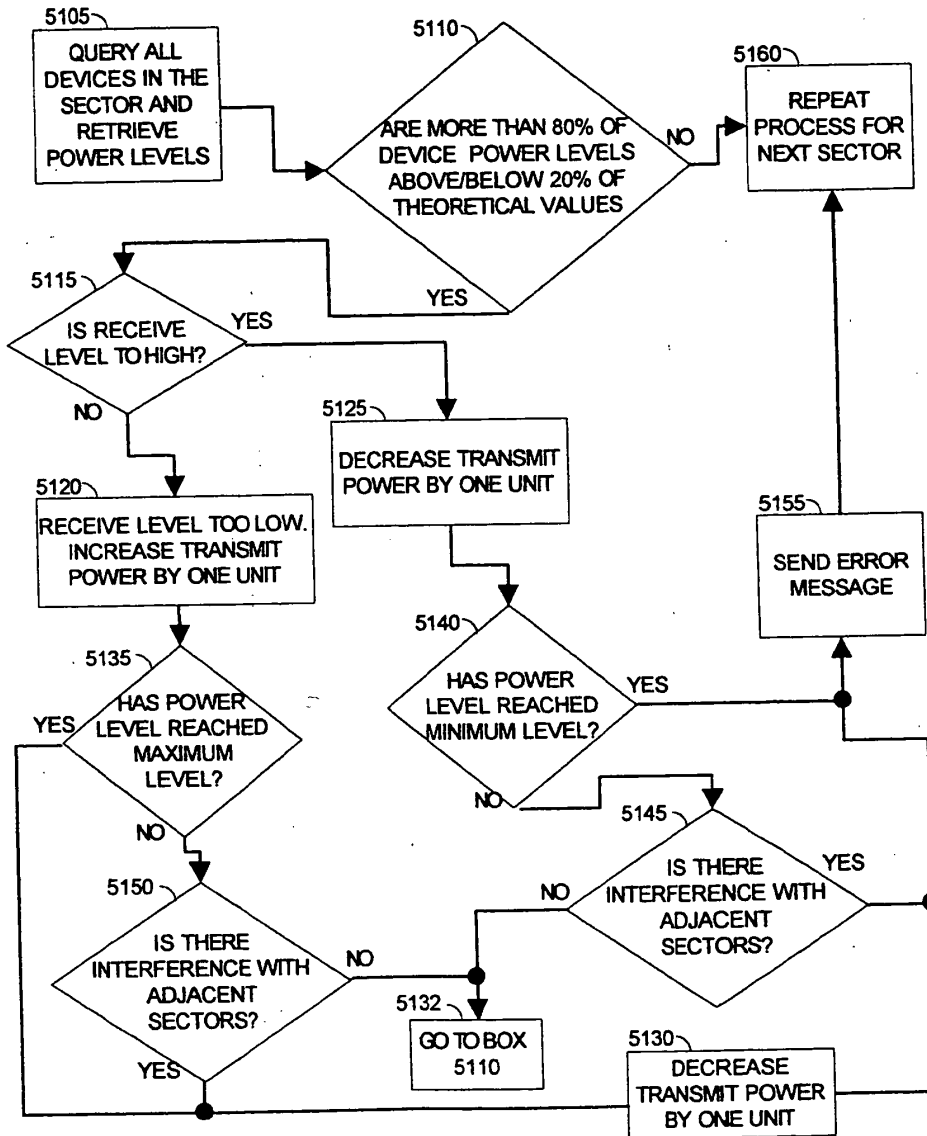

### NTS PRO-ACTIVE SYSTEM MENU

FIG. 52

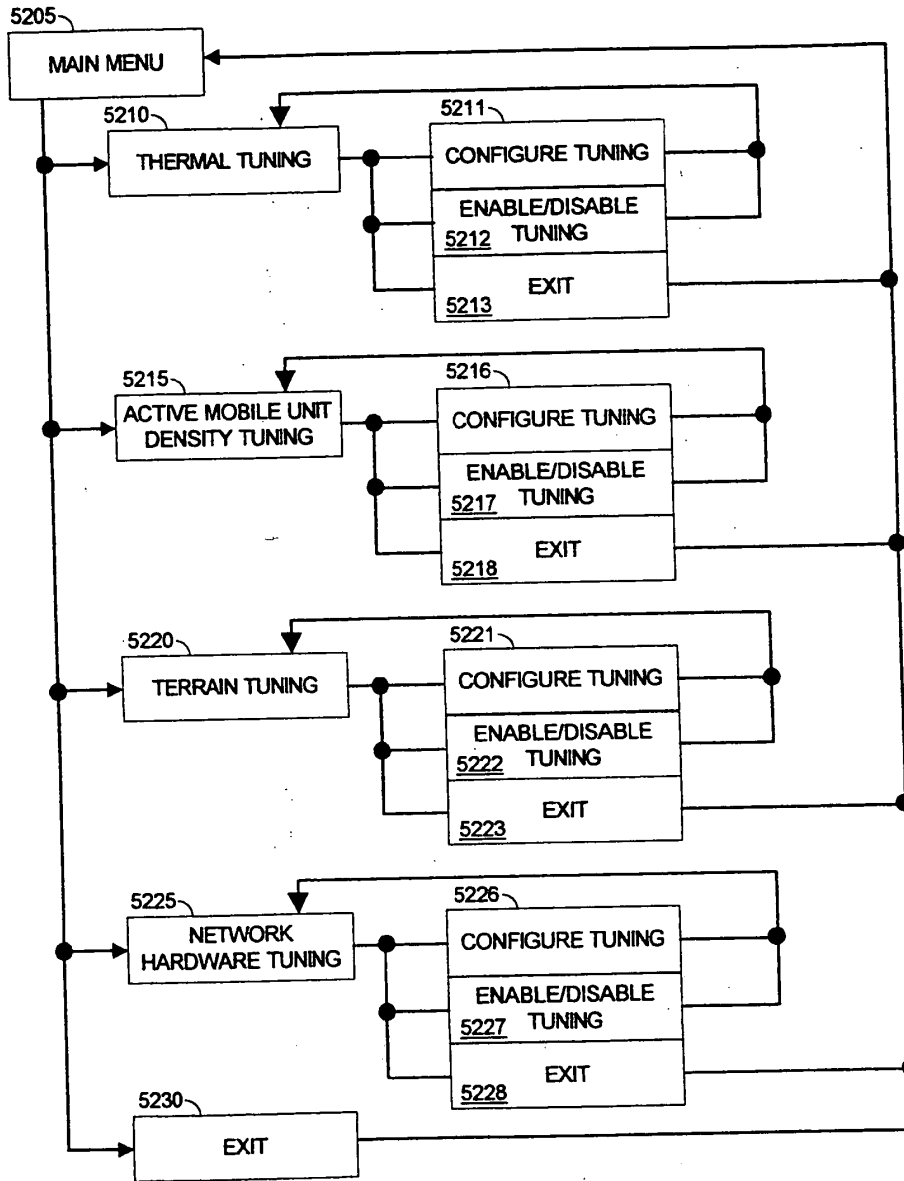

**USER LOGS INTO SYSTEM**

**FIG. 53**

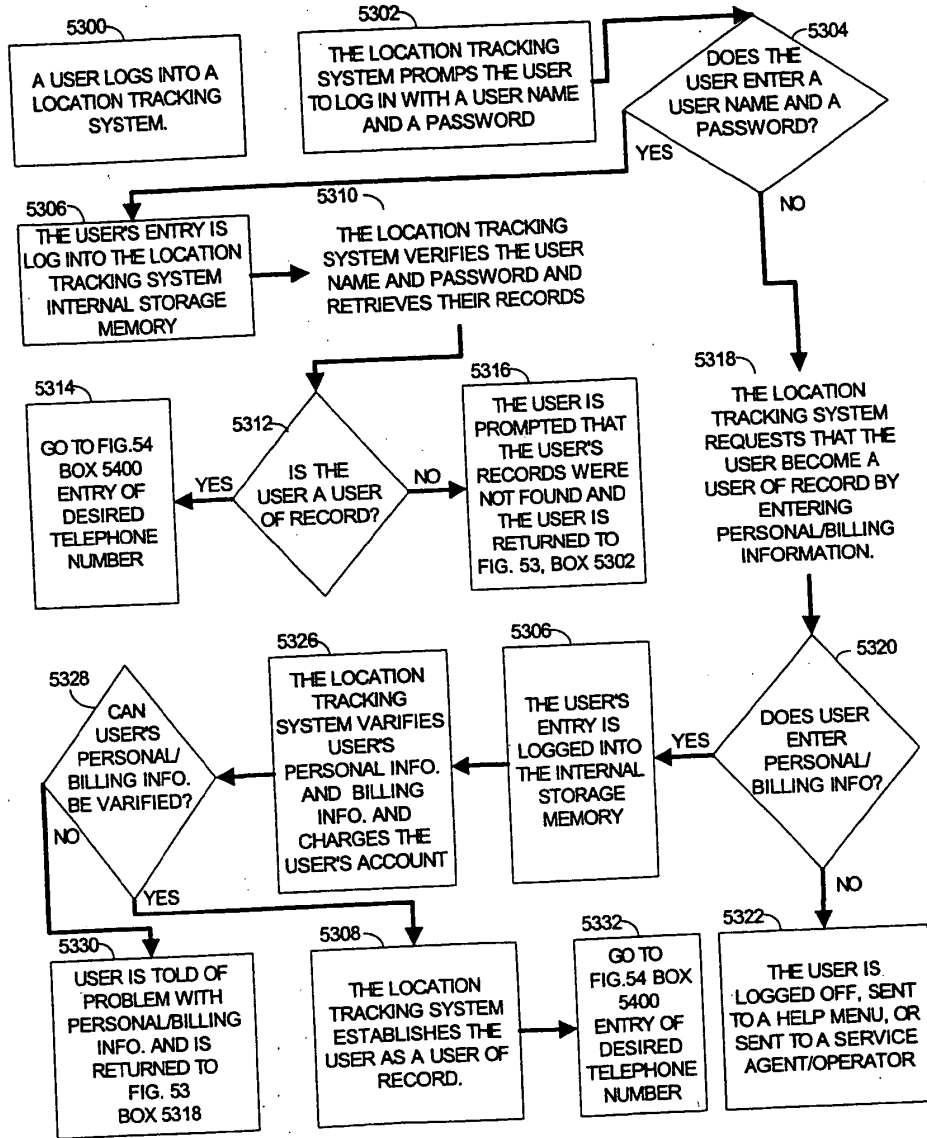

ENTRY OF DESIRED TELEPHONE NUMBER

FIG. 54

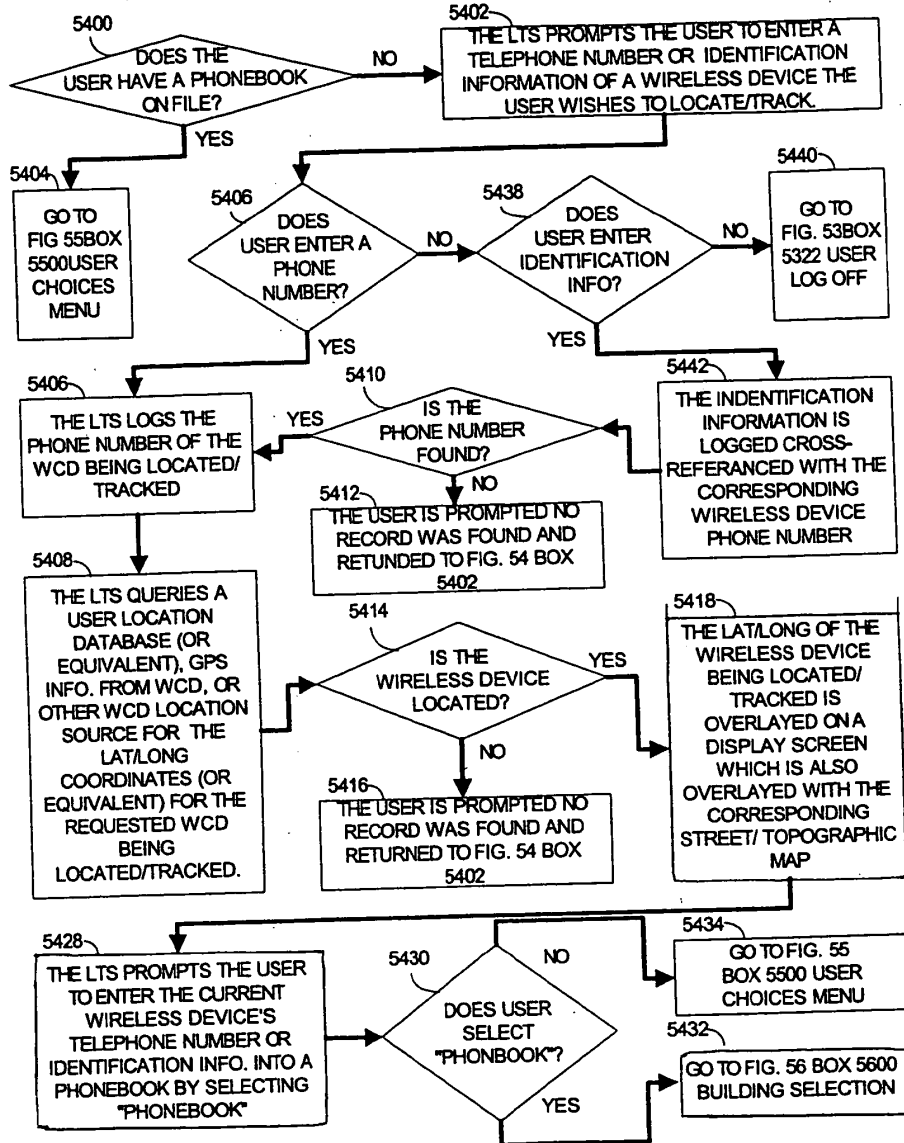



**USER CHOICES MENU**

**FIG. 55**

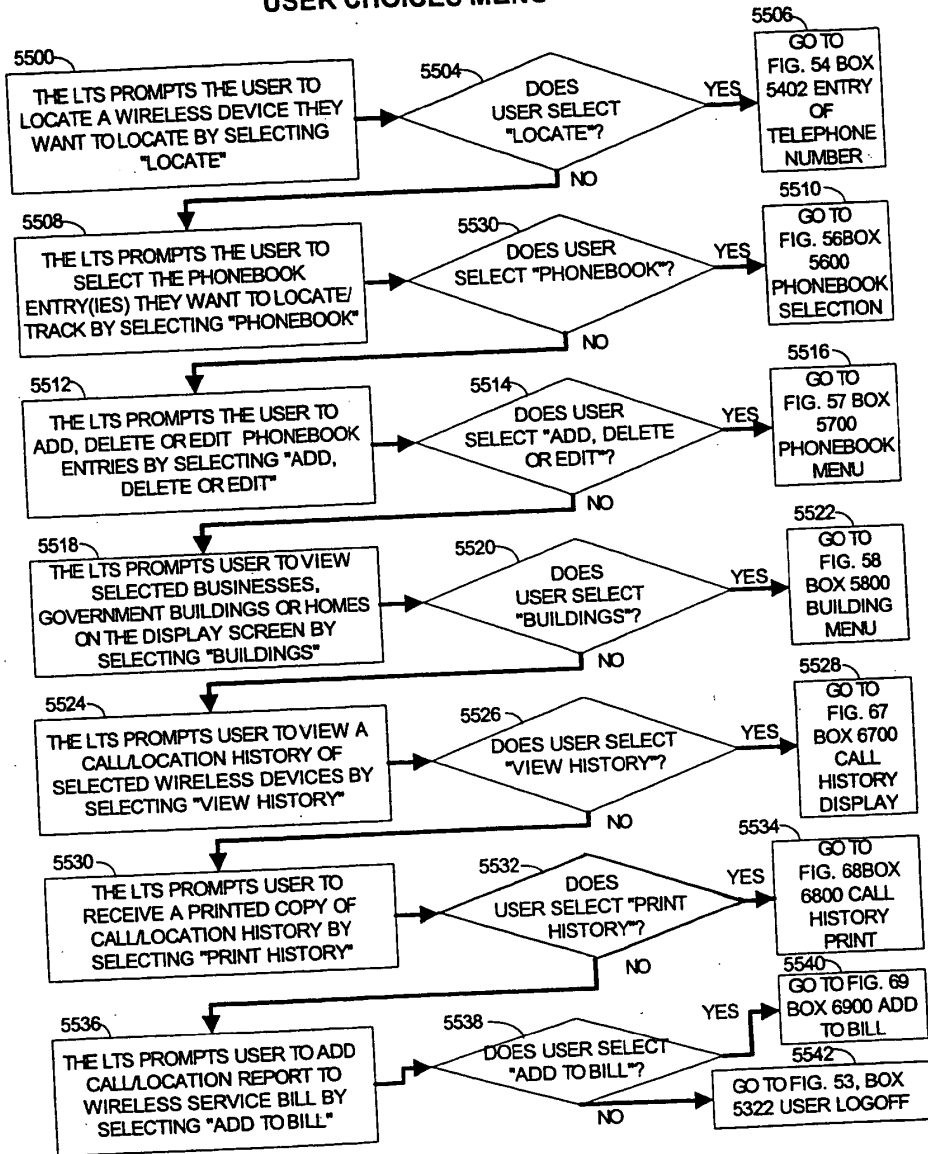

**USER SELECTS BUILDINGS TO DISPLAY FIG. 56**

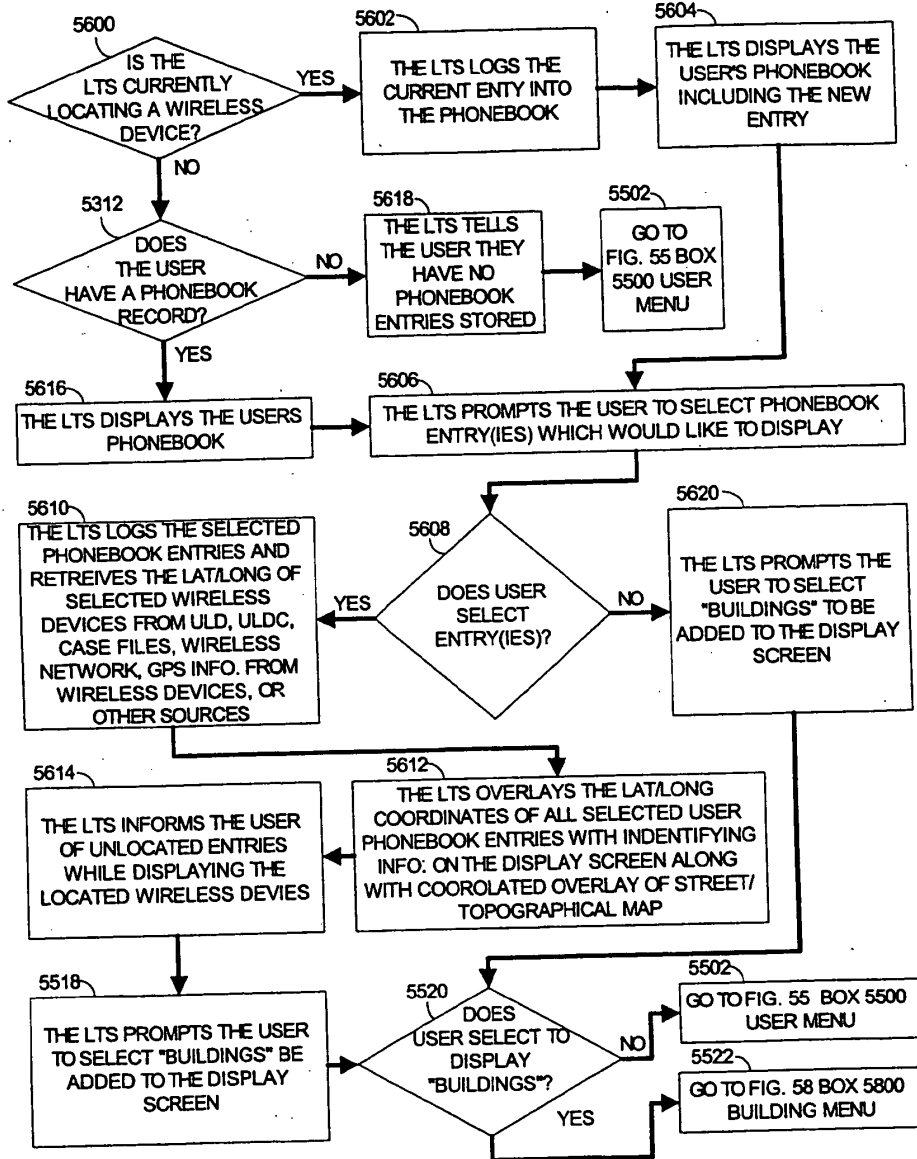

### ADDING, DELETING AND EDITING PHONEBOOK ENTRIES

FIG. 57

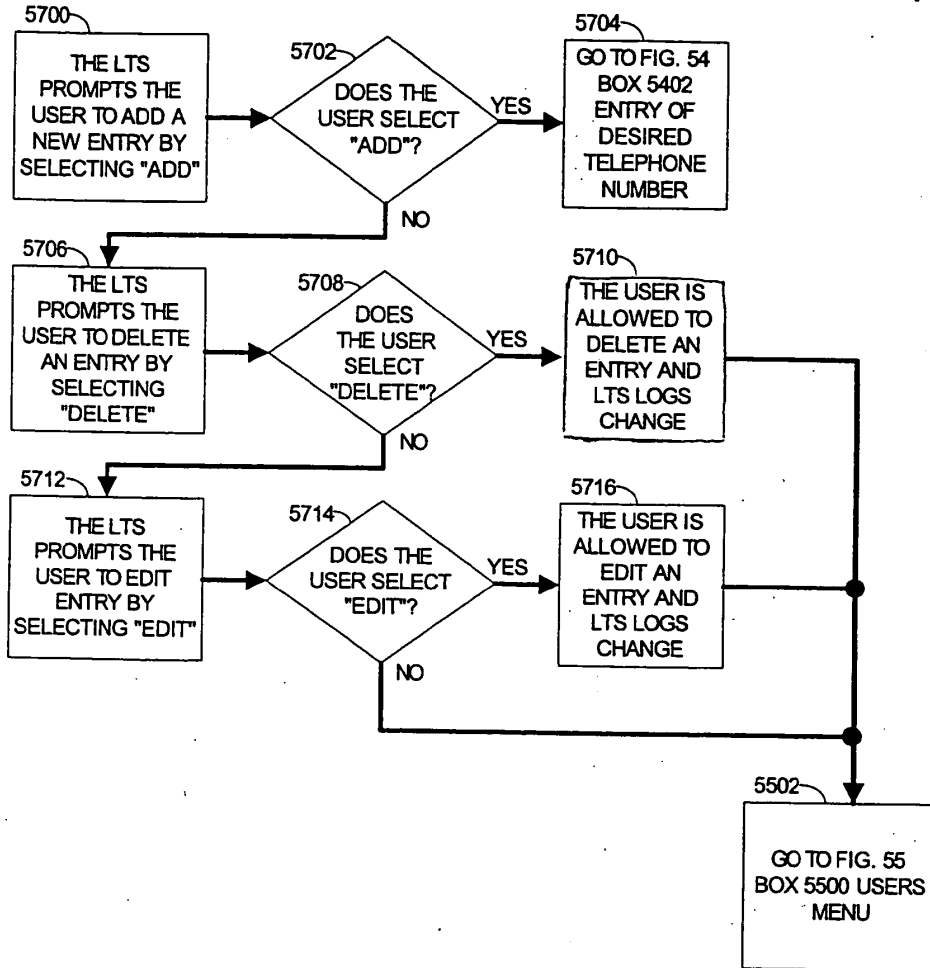

**USER SELECTION ON BUILDING TO DISPLAY**

**FIG. 58**

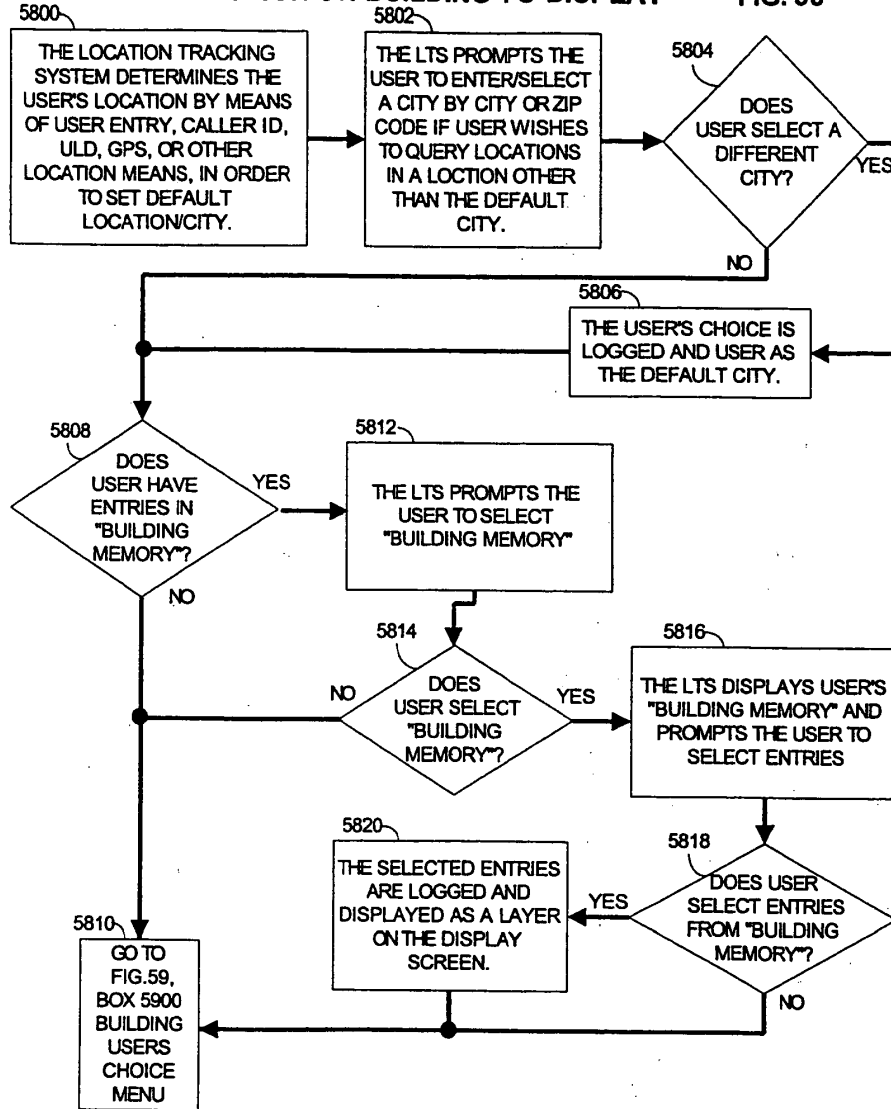

**"BUILDING MEMORY" USER'S CHOICE MENU**

**FIG. 59**

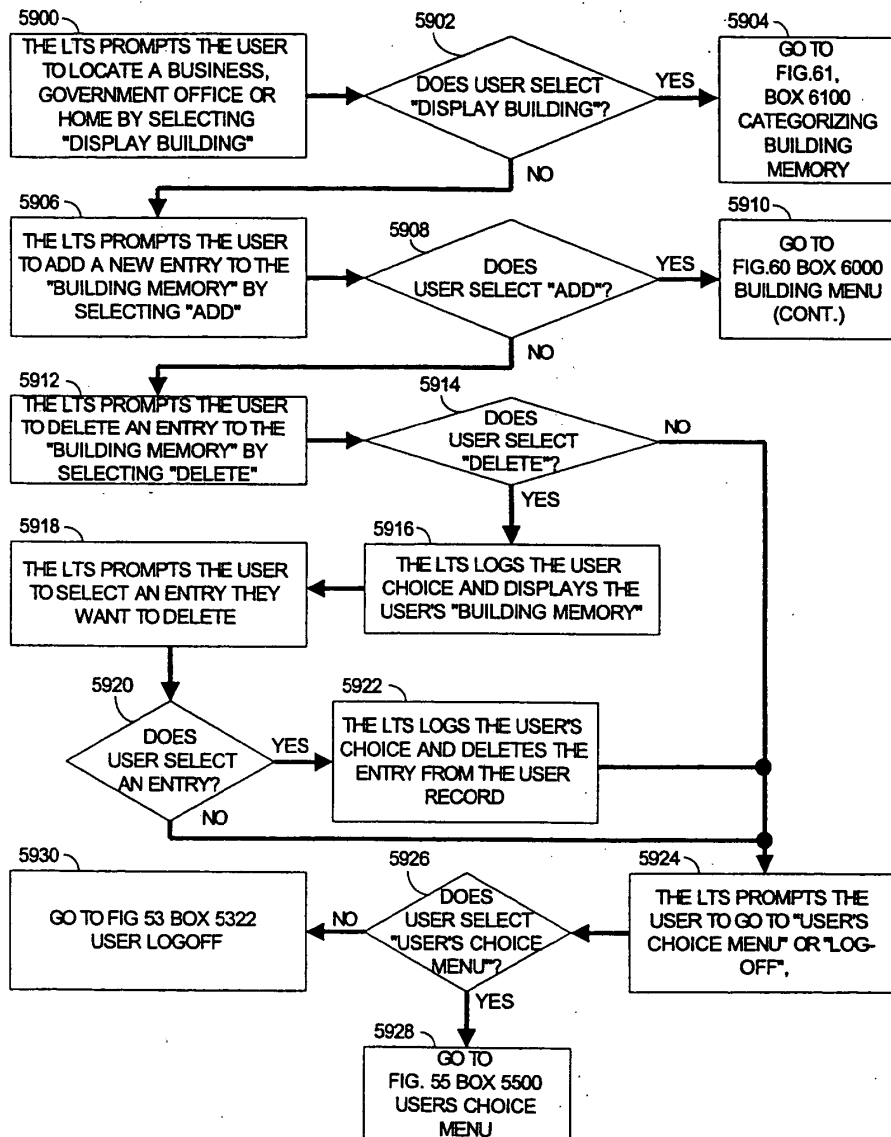

"BUILDING MEMORY" CONTINUED

FIG. 60

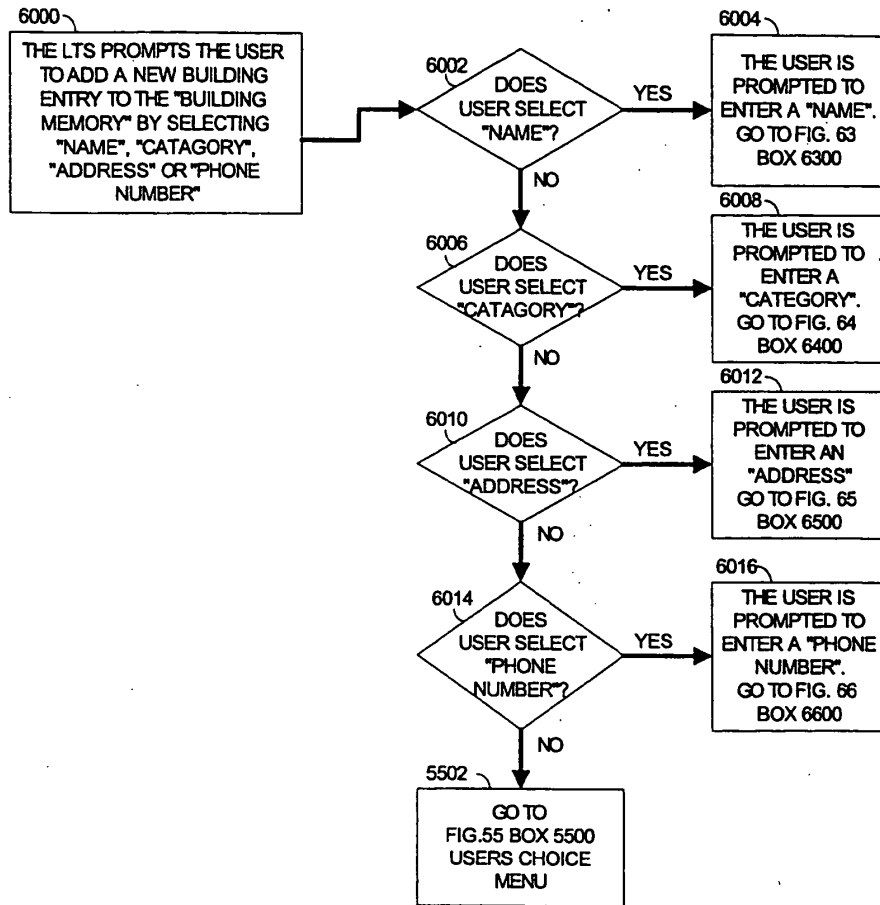

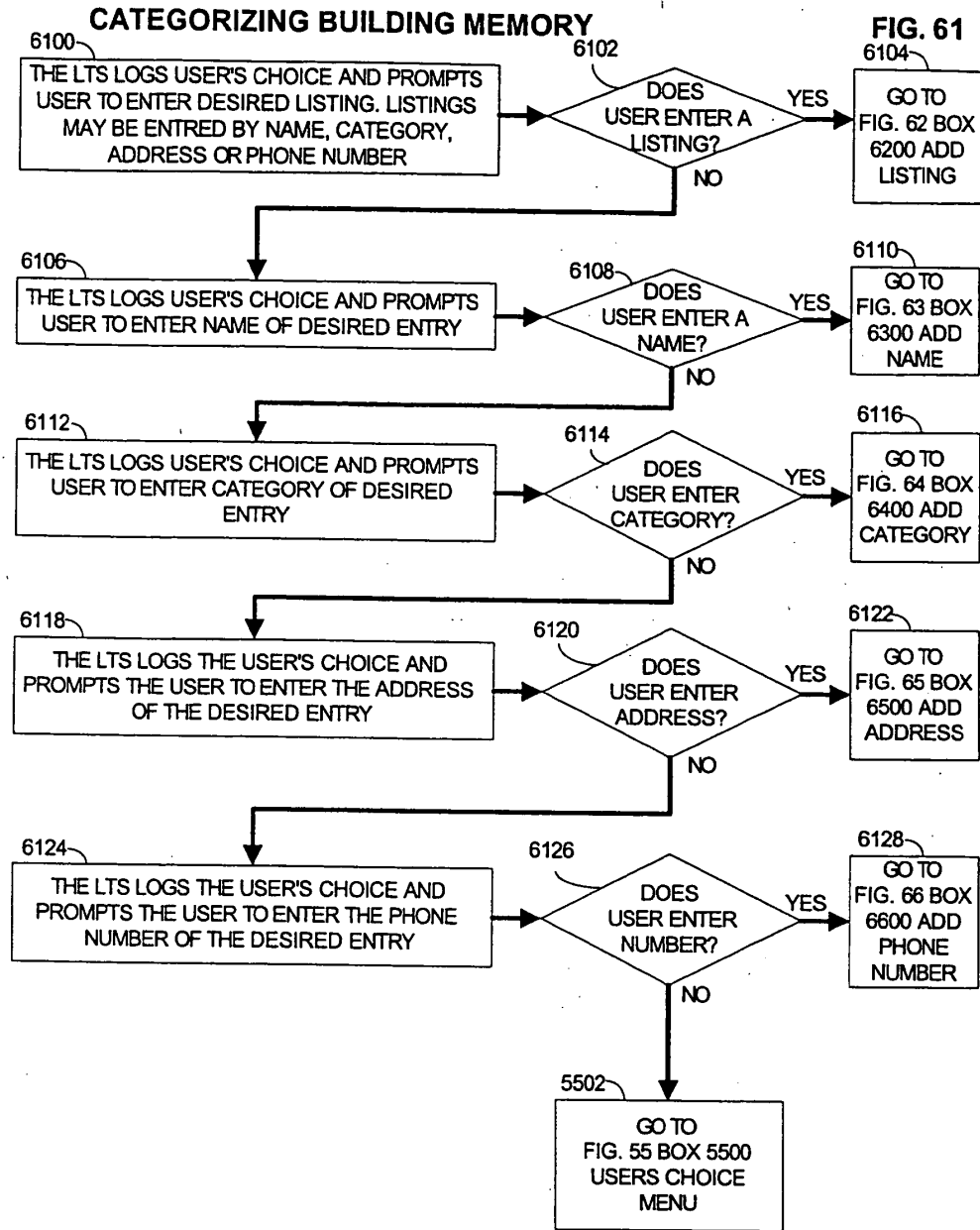

"LISTING" ADDED TO "BUILDING MEMORY"

FIG. 62

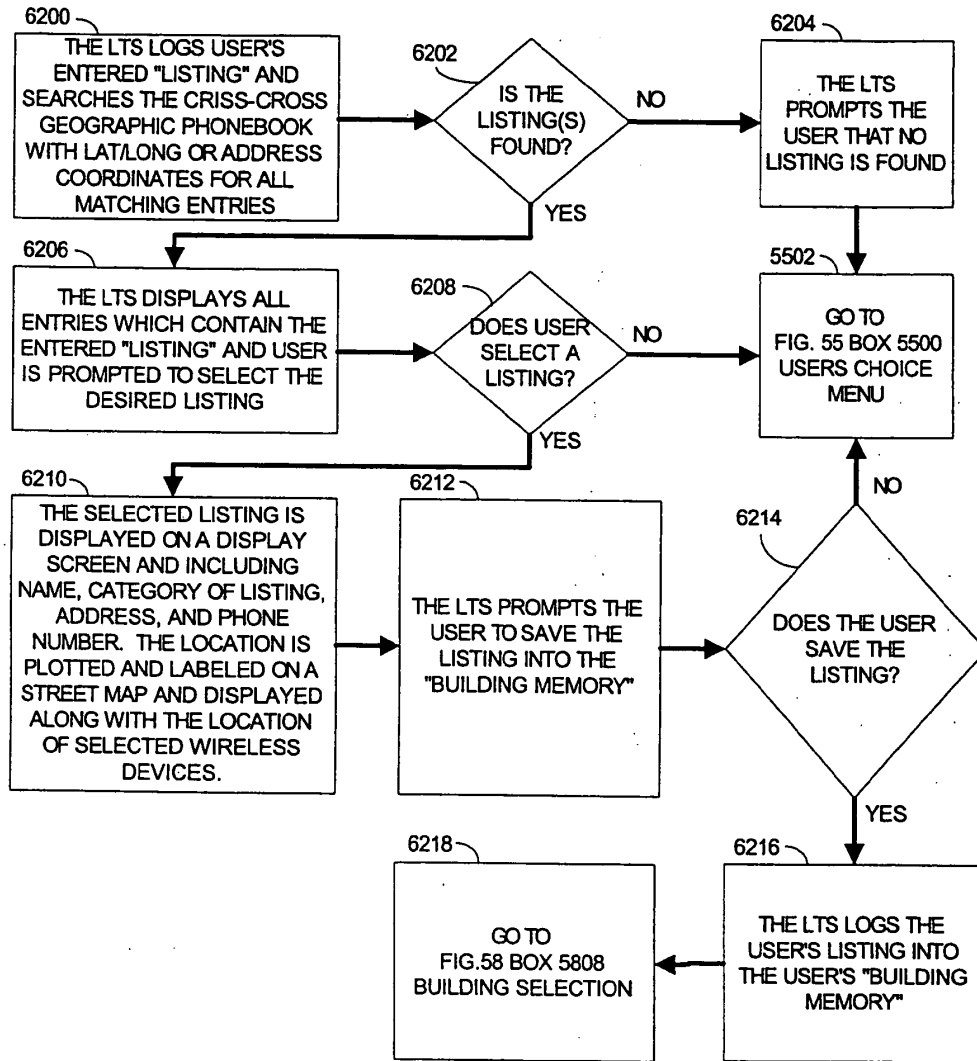



"NAME" ADDED TO "BUILDING MEMORY"

FIG. 63

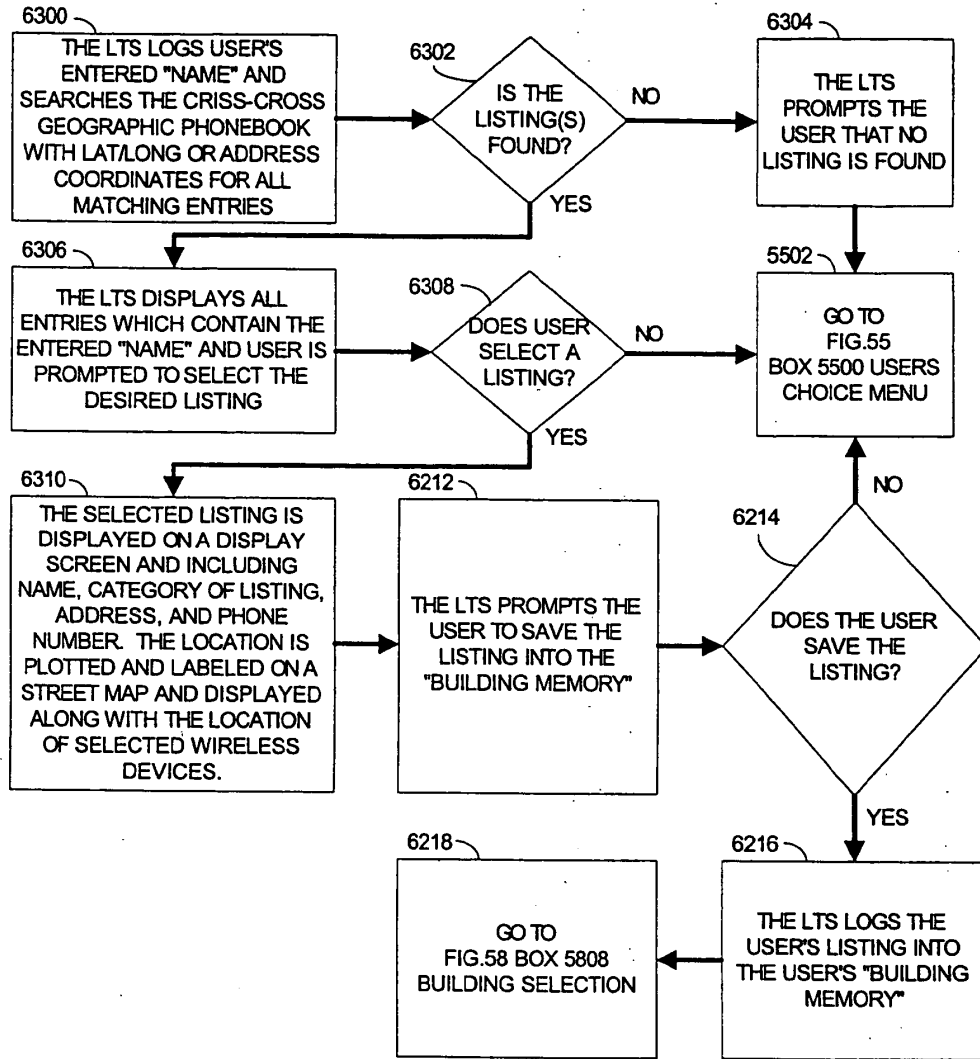

### "CATEGORY" ADDED TO "BUILDING MEMORY"

FIG. 64

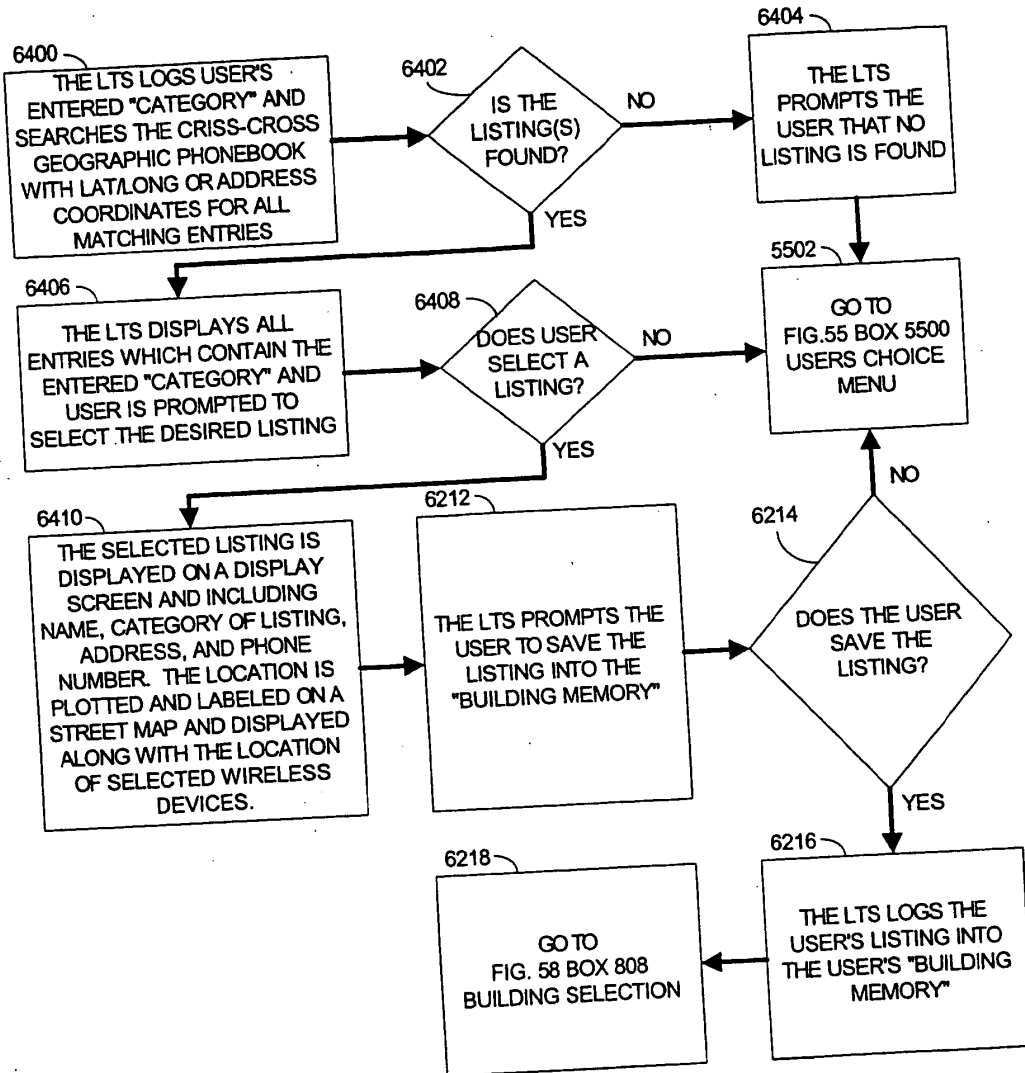

### "ADDRESS" ADDED TO "BUILDING MEMORY"

FIG. 65

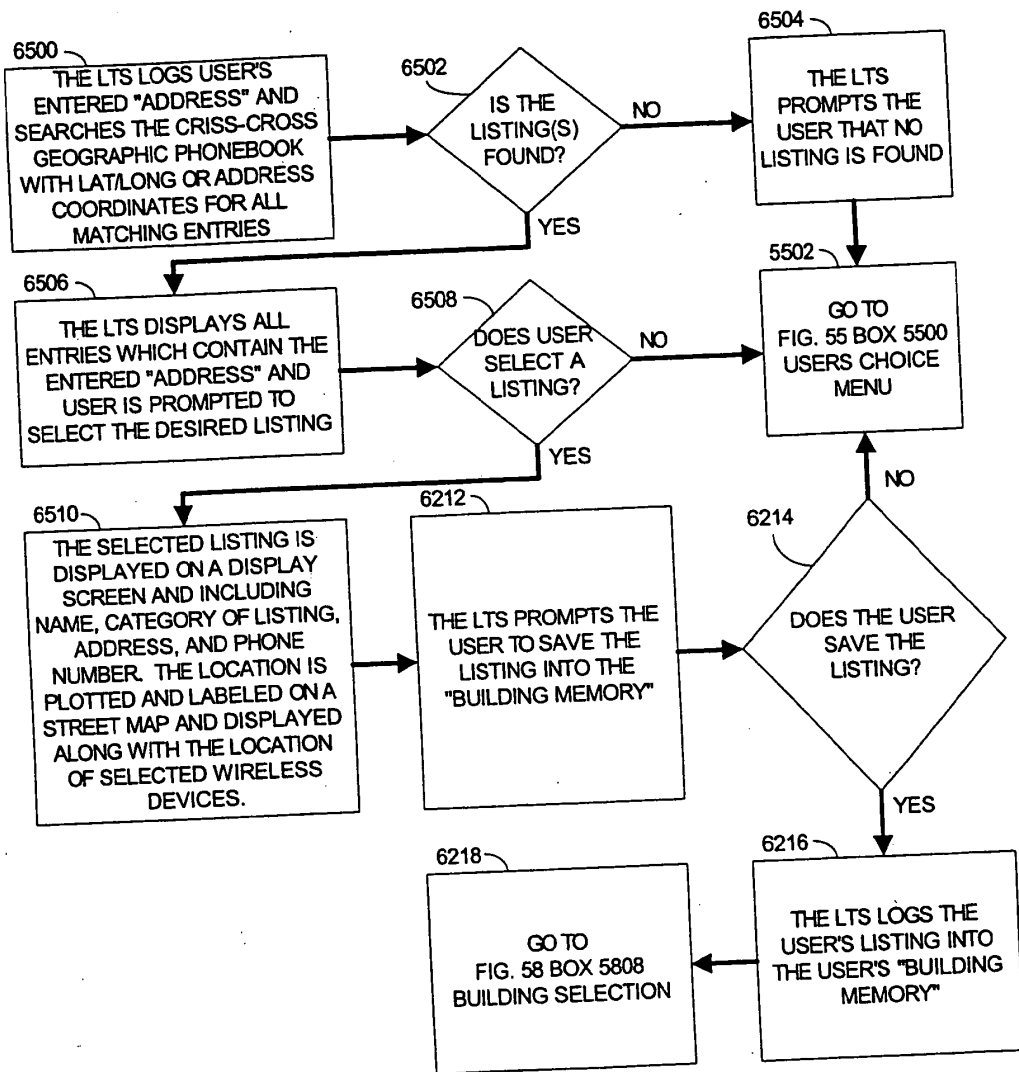

### "PHONE NUMBER" ADDED TO "BUILDING MEMORY" FIG. 66

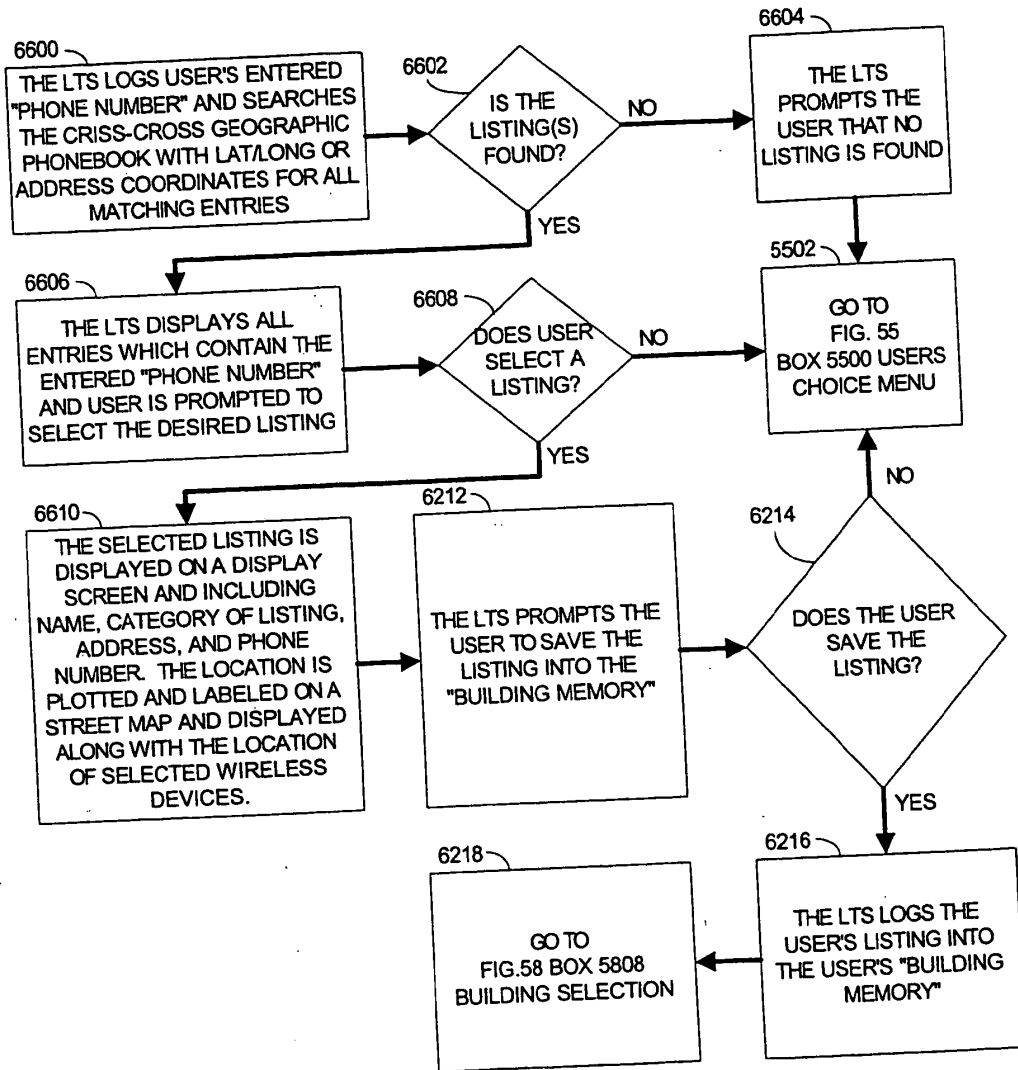

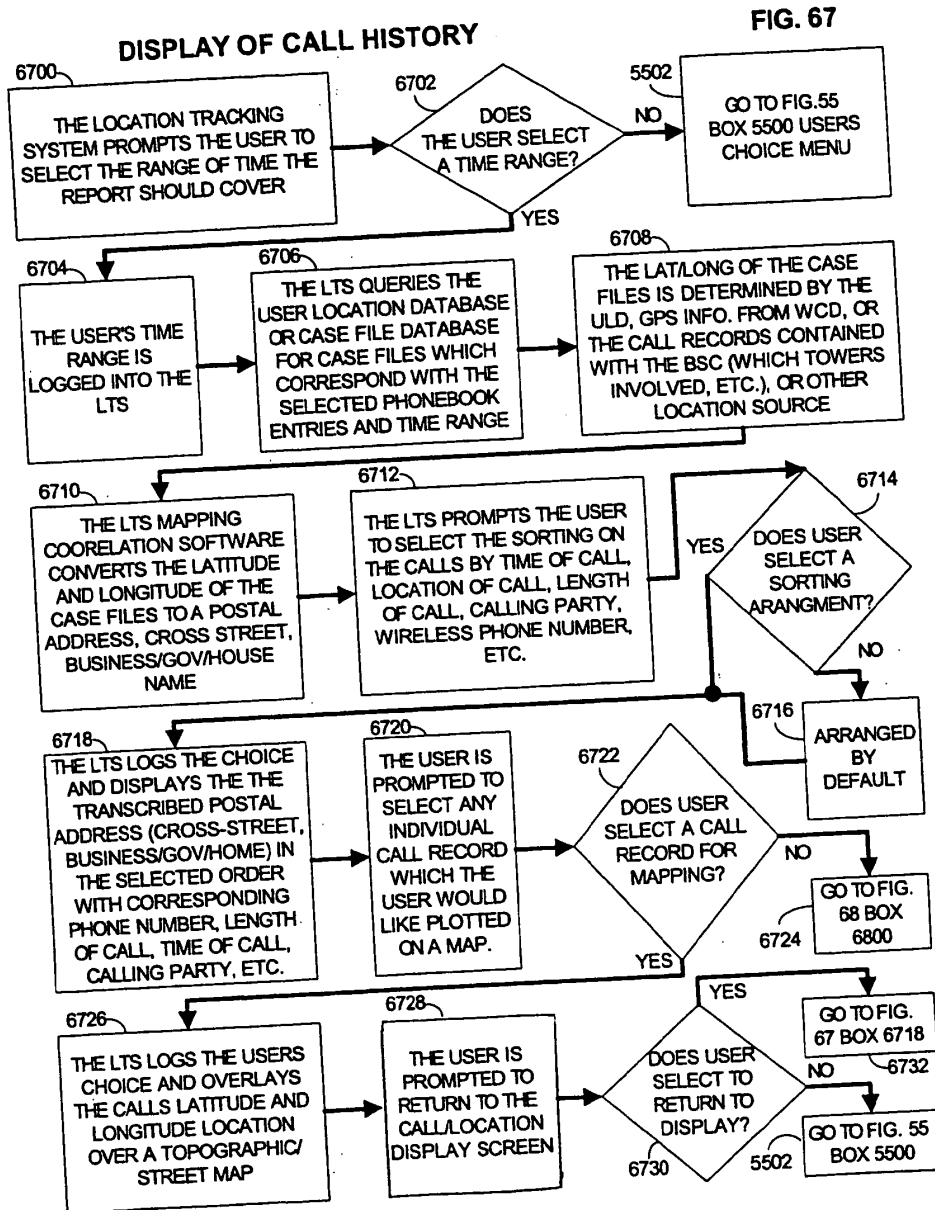

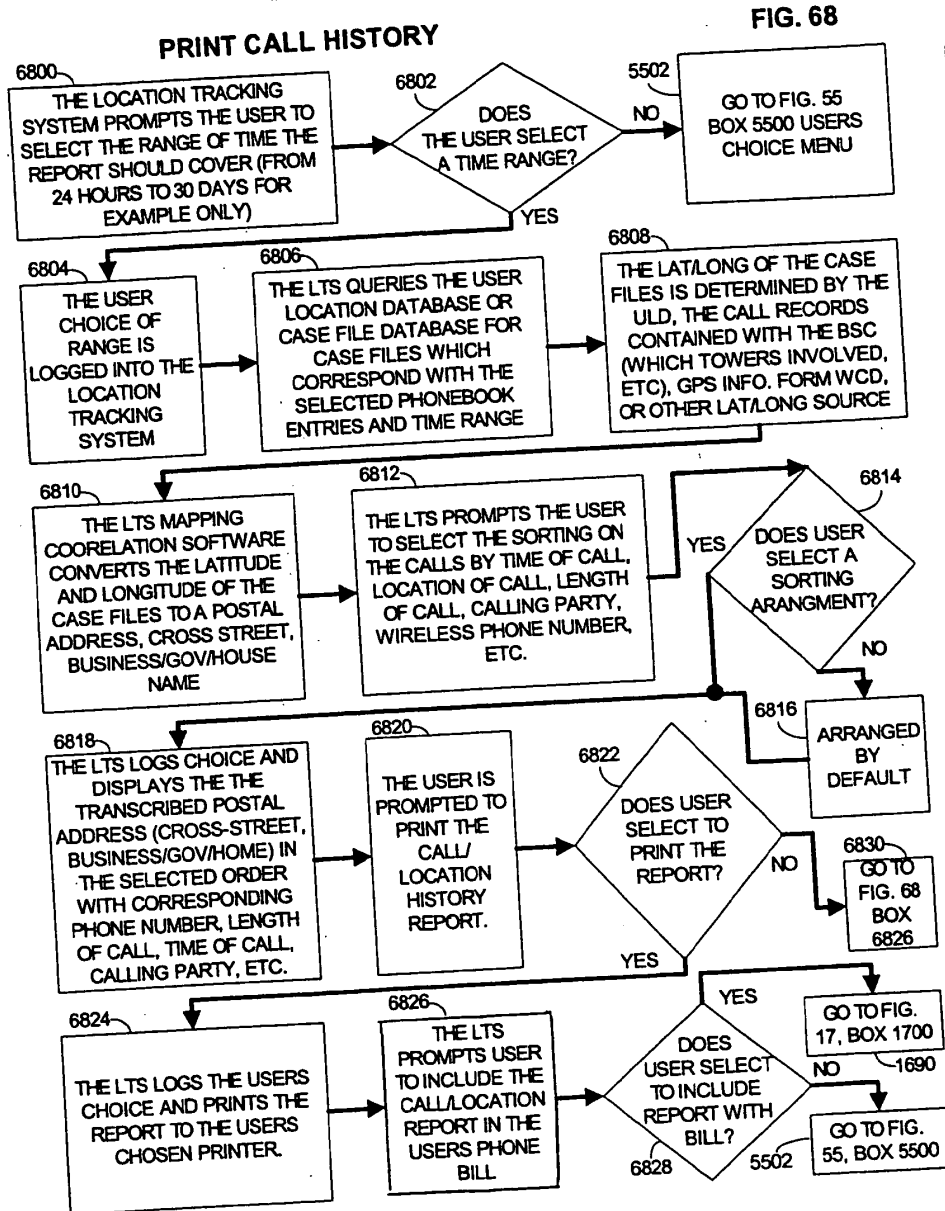

ADD CALL/LOCATION HISTORY TO PHONE BILL FIG. 69

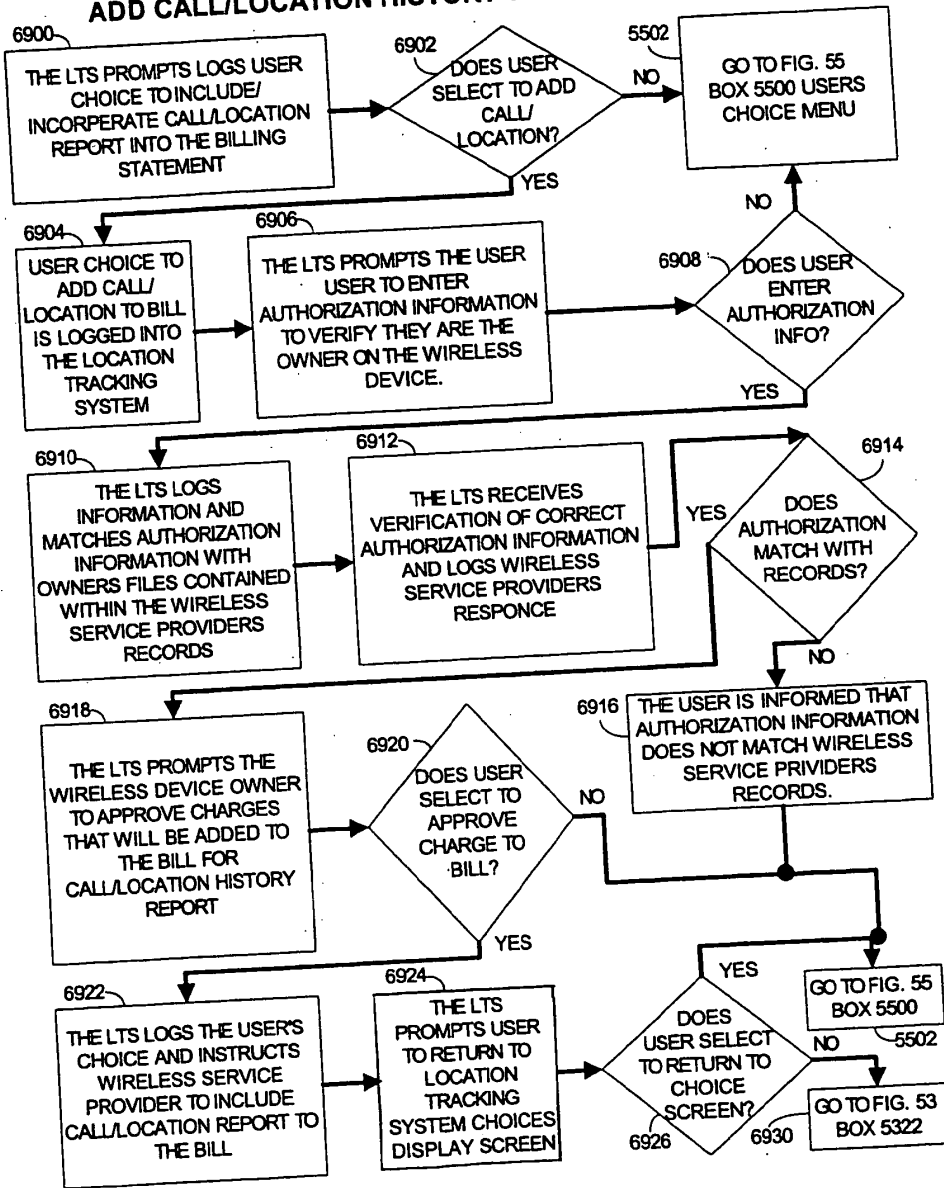

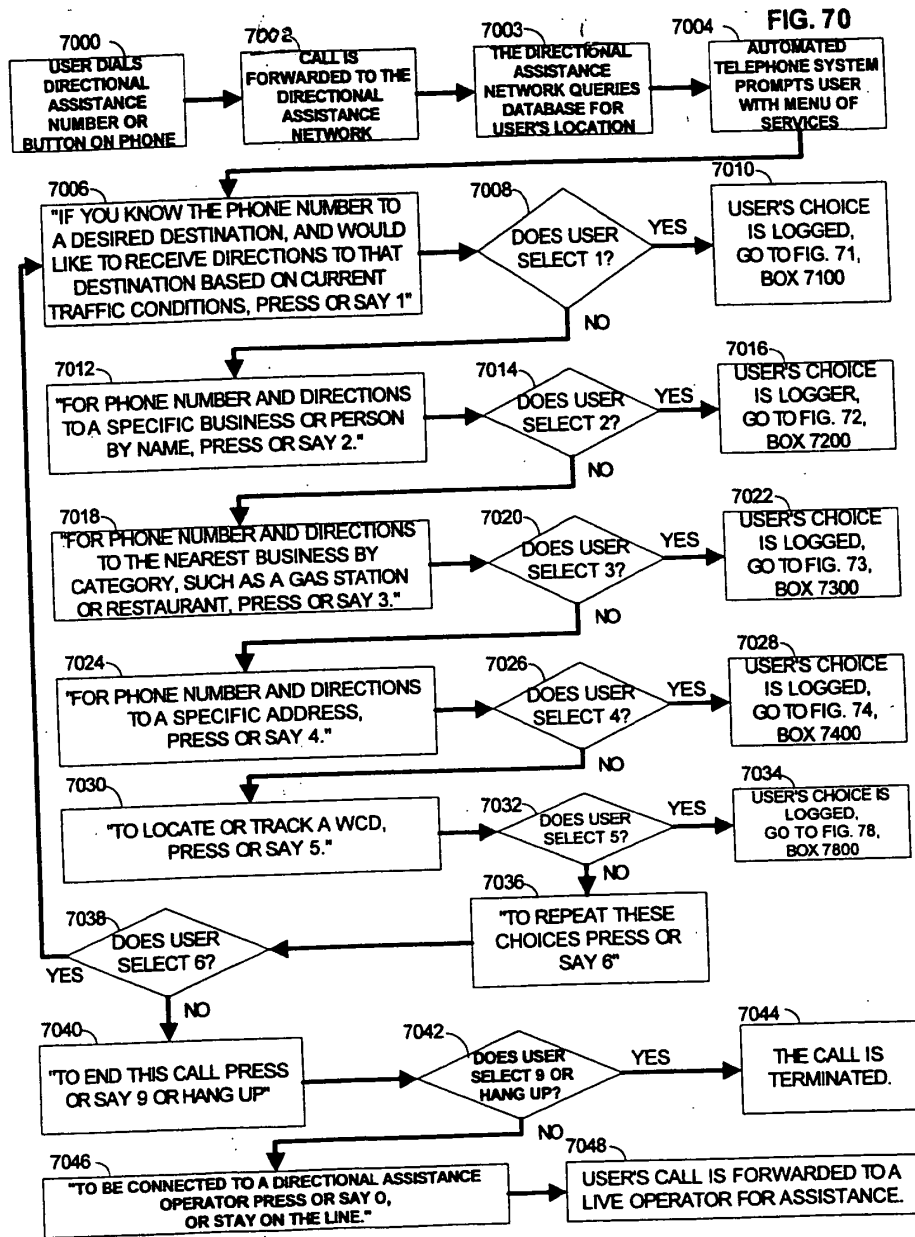



FIG. 71

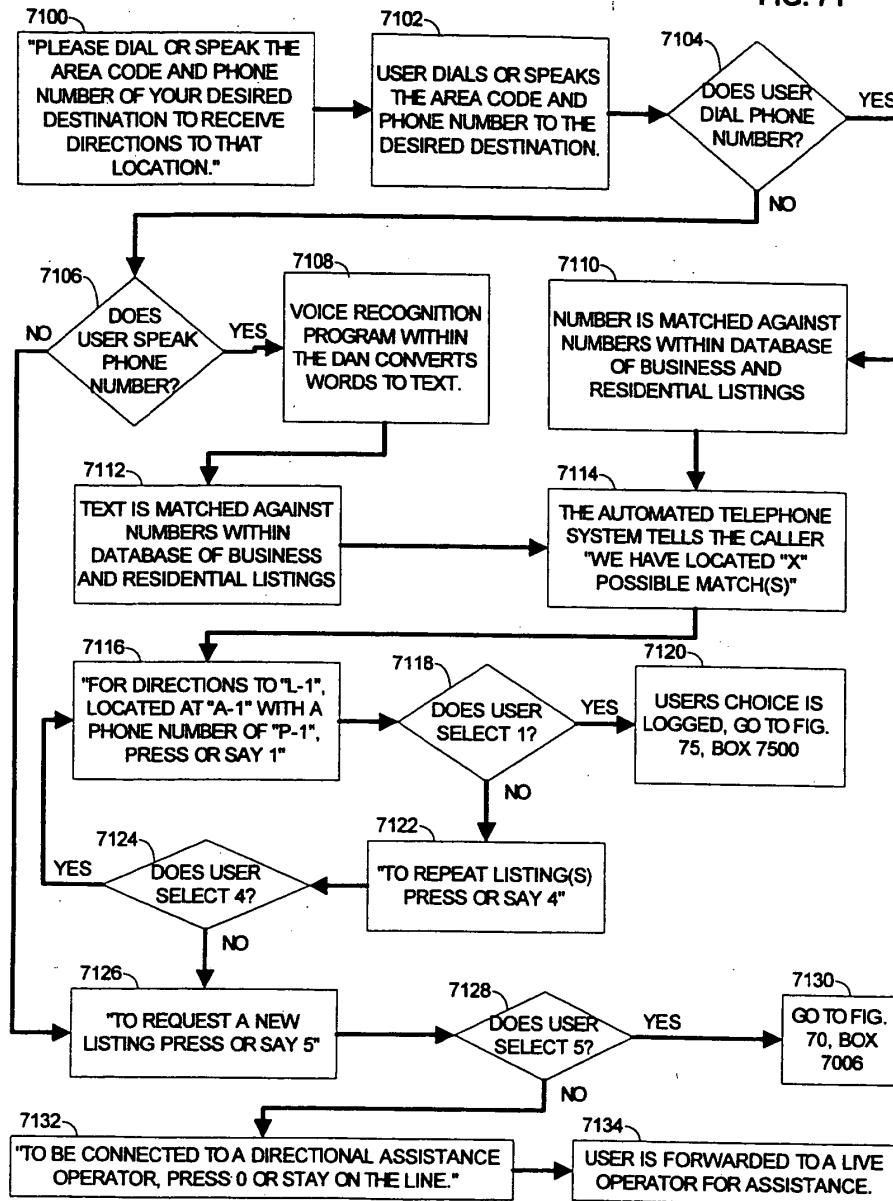
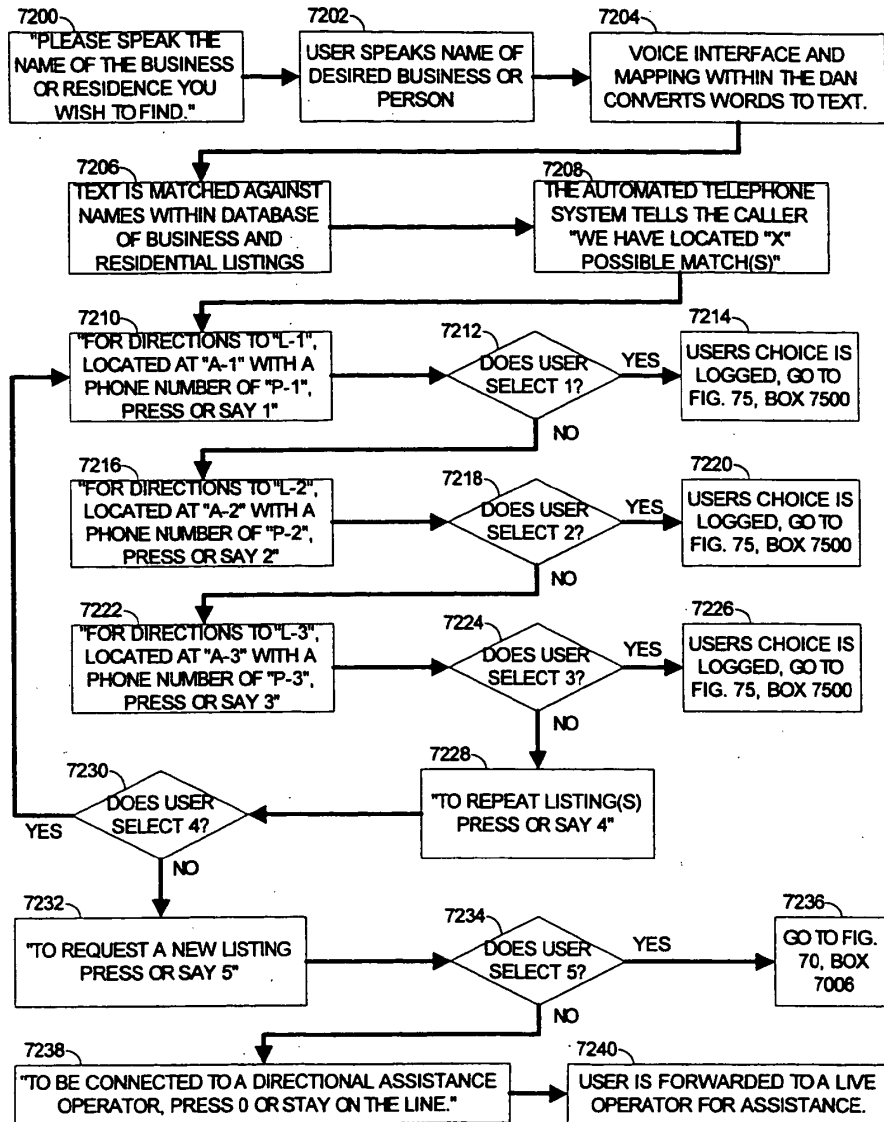

FIG. 72



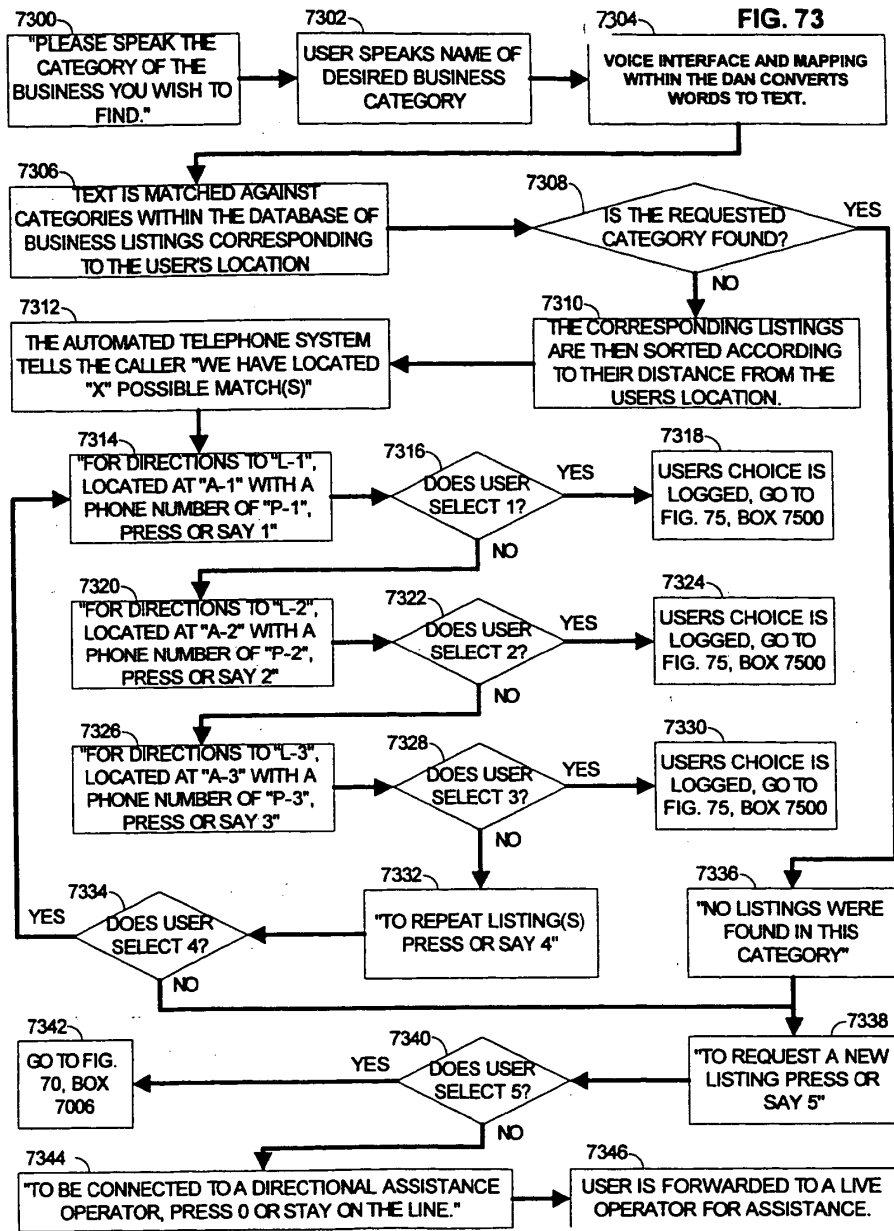
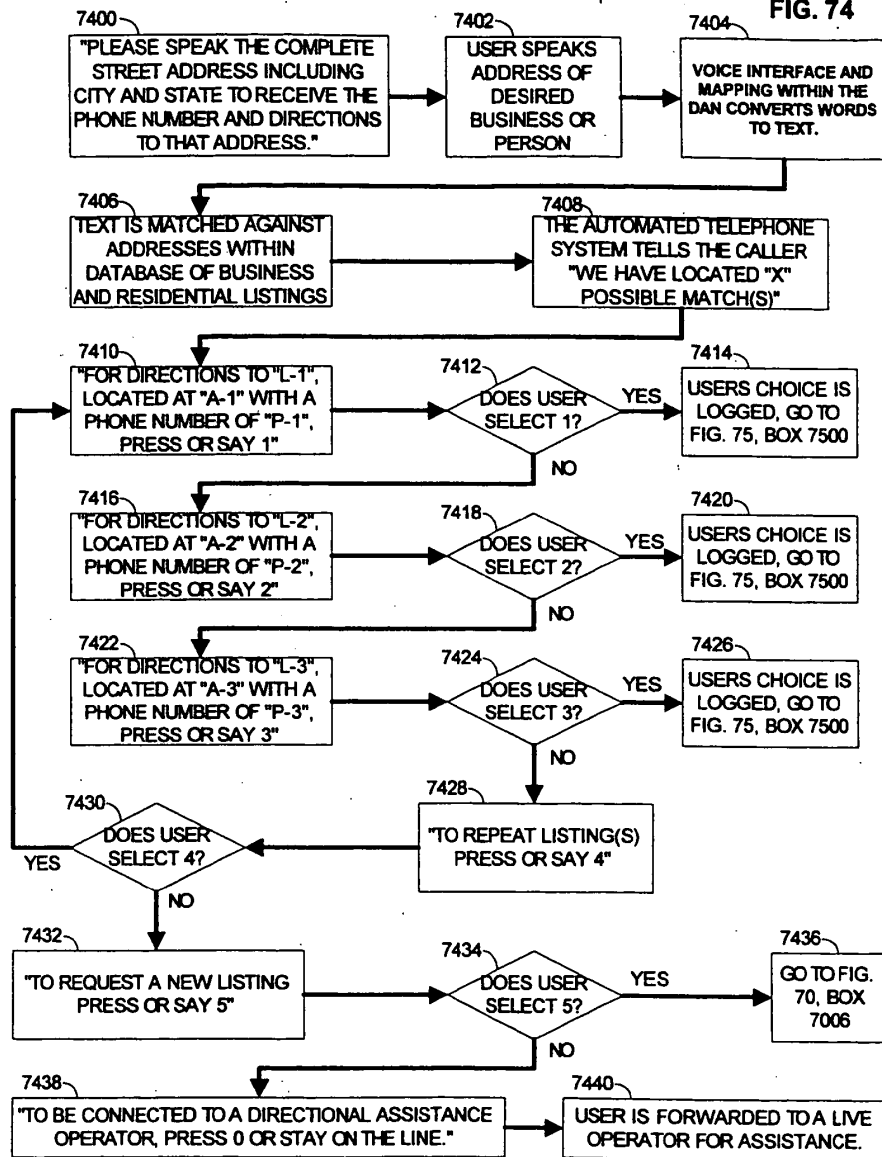
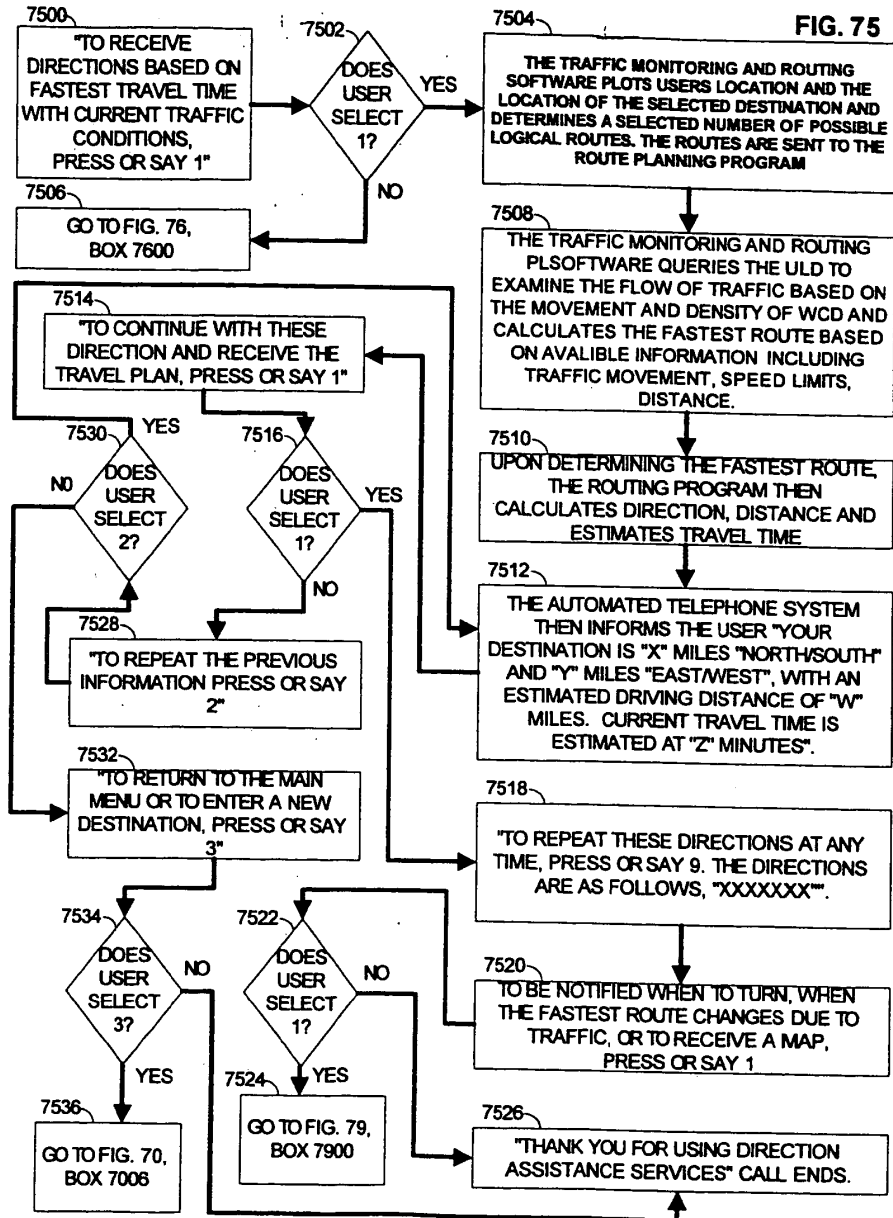

FIG. 74





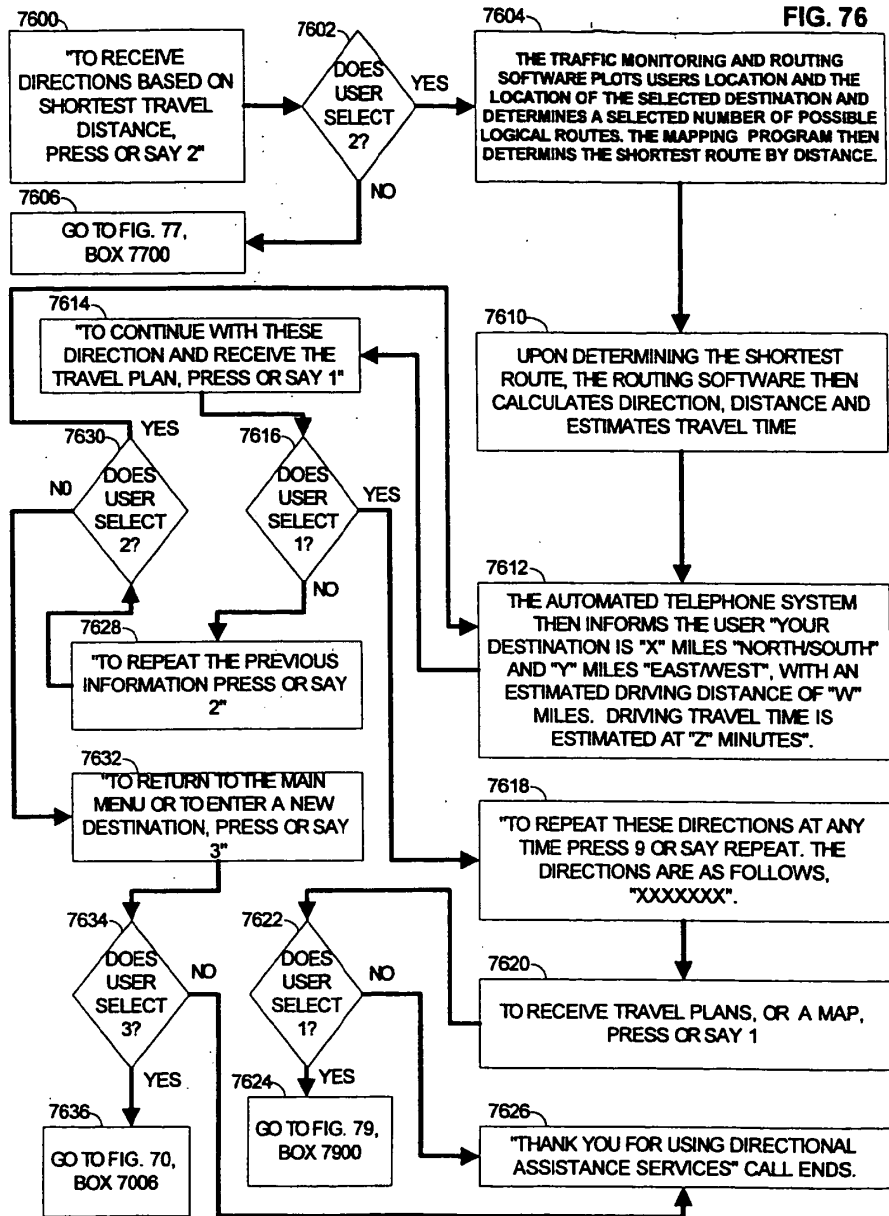
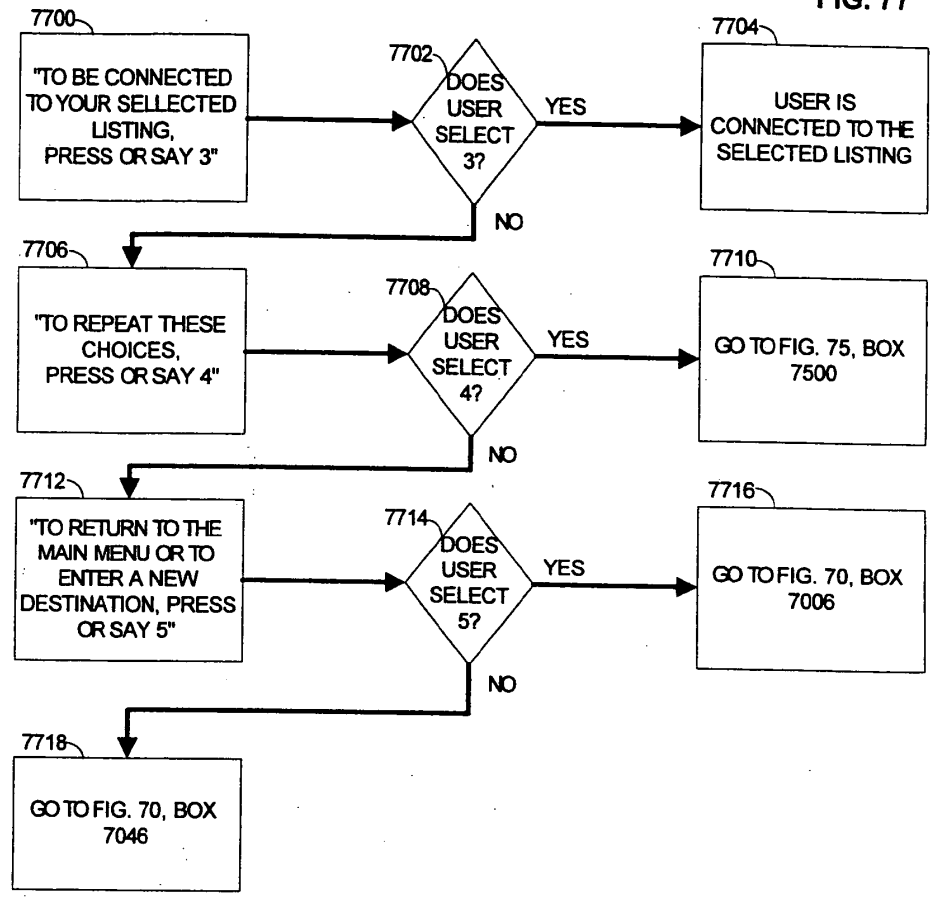
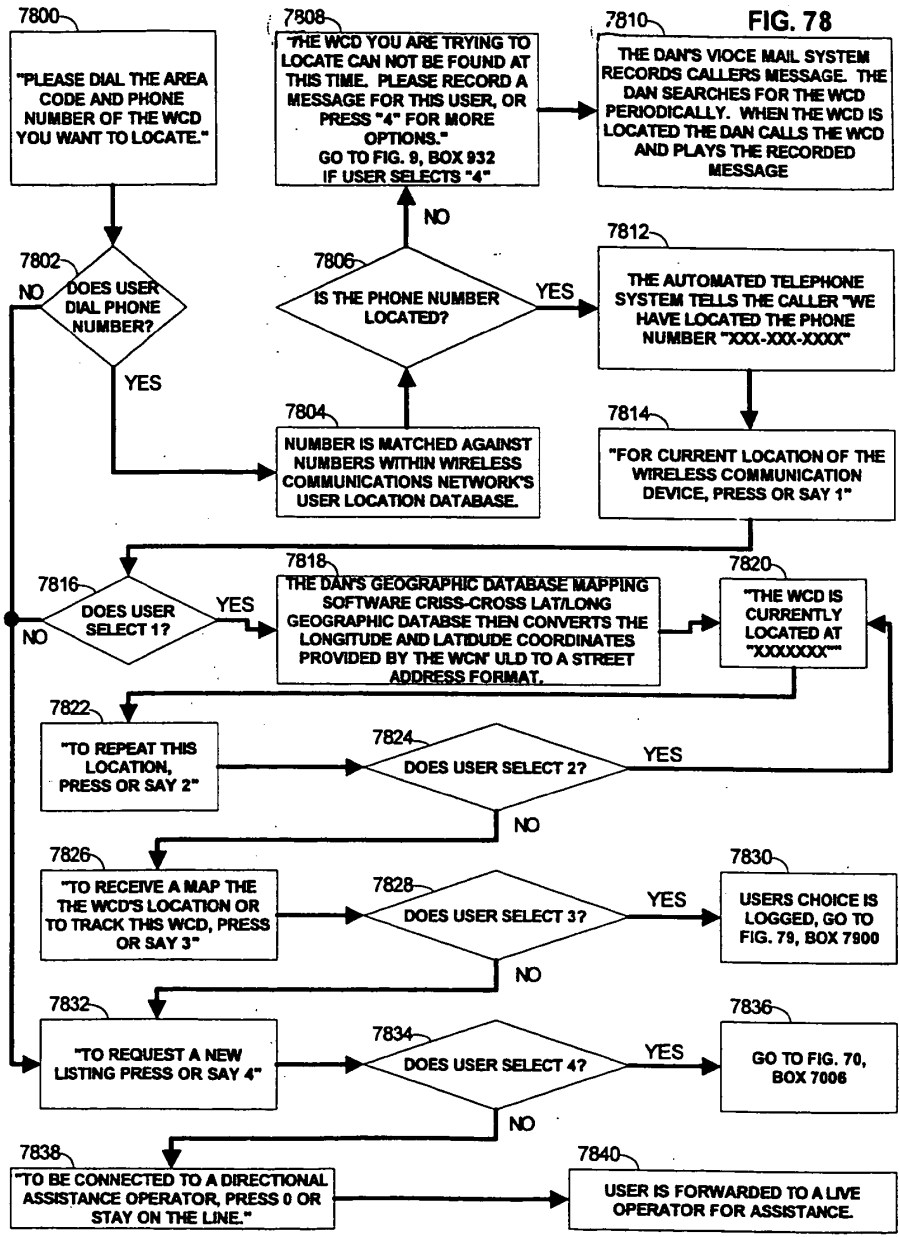
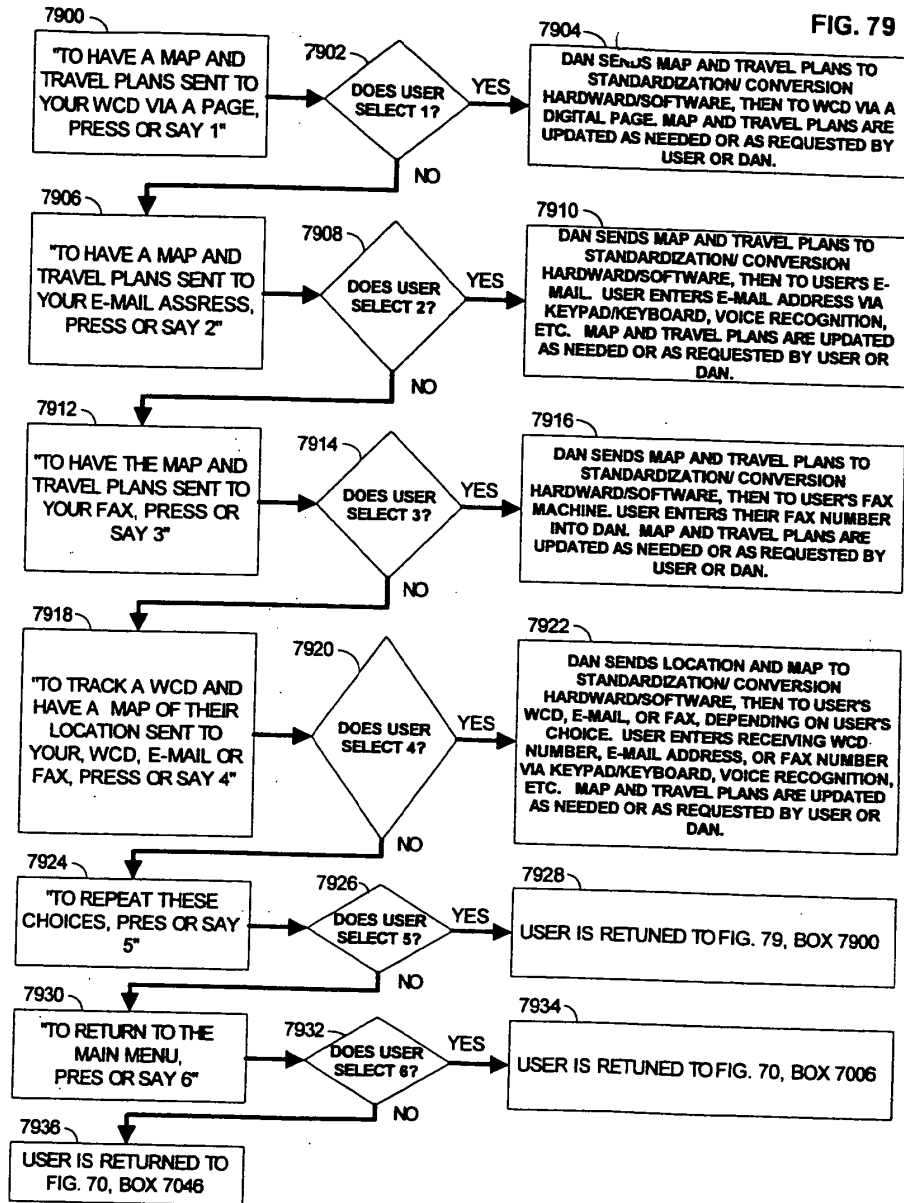

FIG. 77







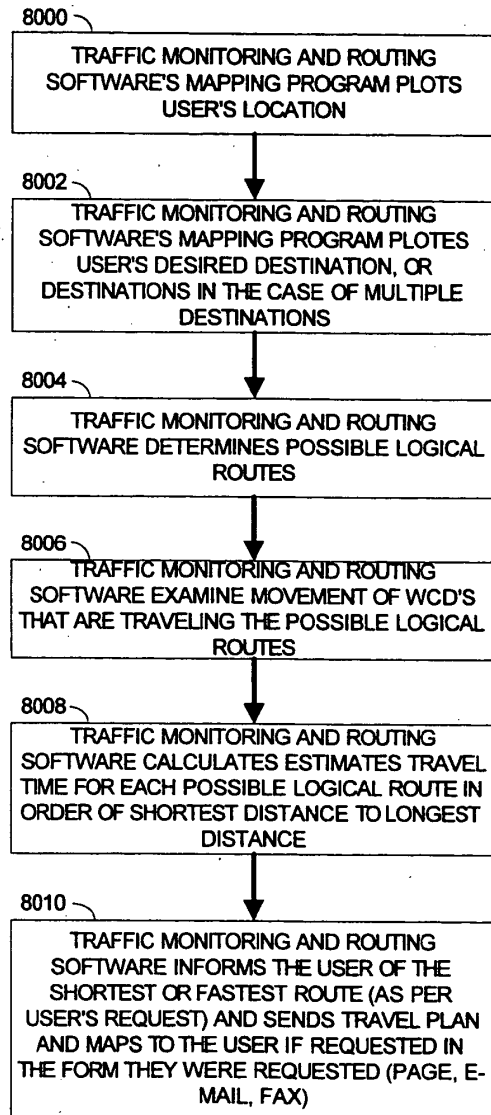

**TRAFFIC MONITORING AND ROUTING  
SOFTWARE PROCESS FLOWCHART****FIG. 80**

DIRECTIONAL ASSISTANCE NETWORK STRUCTURE FIG. 81

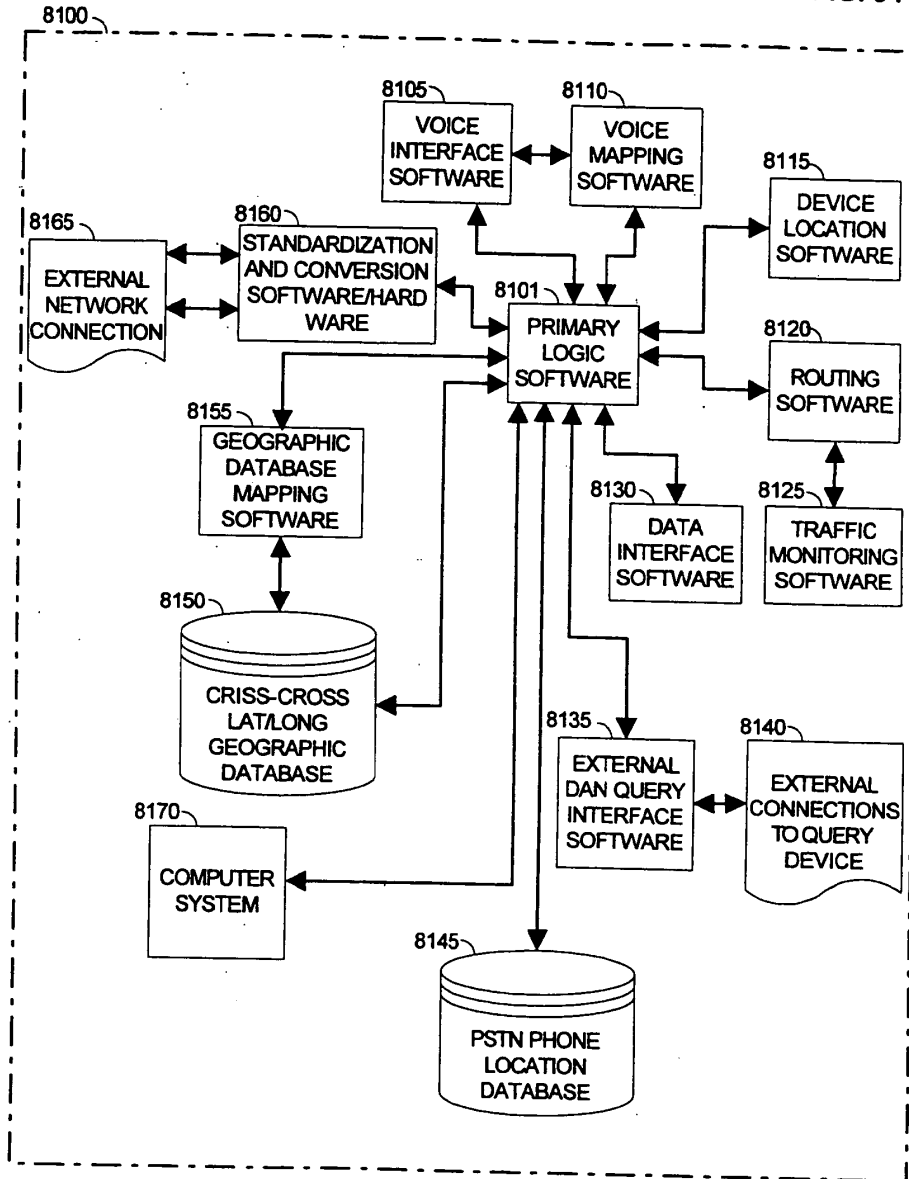

PRIMARY EMBODIMENT'S LOCATION ON A TYPICAL 2/3G CELLULAR NETWORK FIG. 82

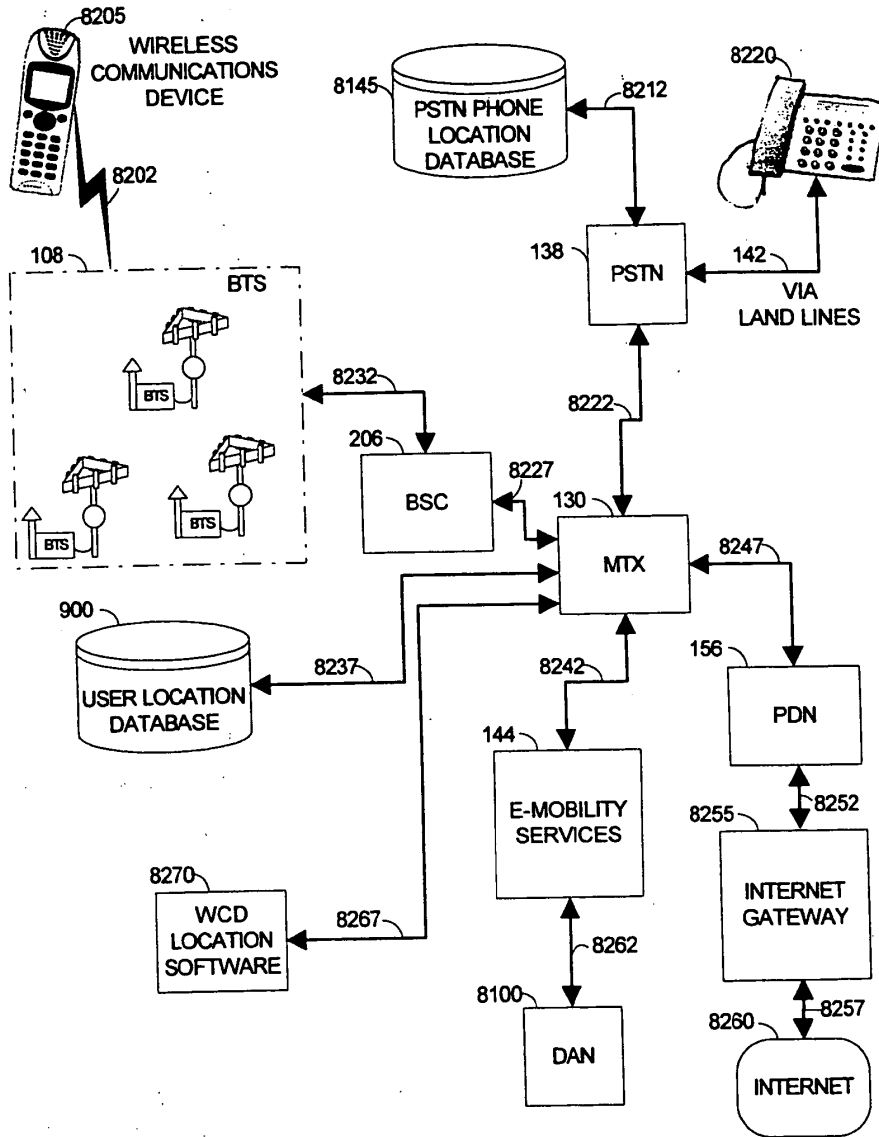

PRIMARY EMBODIMENT'S ALTERNATE LOCATION ON A TYPICAL 2/3G CELLULAR NETWORK FIG. 83

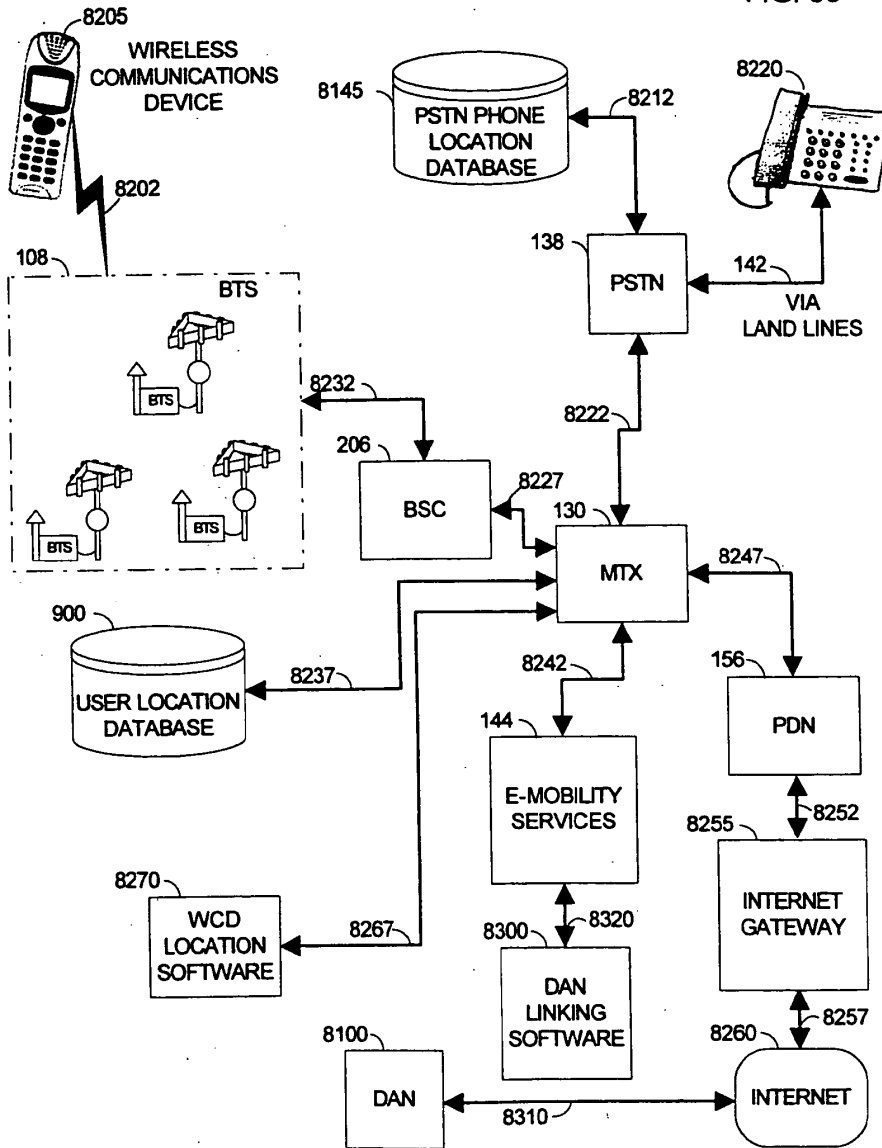

PRIMARY EMBODIMENT'S ALTERNATE LOCATION #2 ON A TYPICAL 2/3G CELLULAR NETWORK FIG. 84

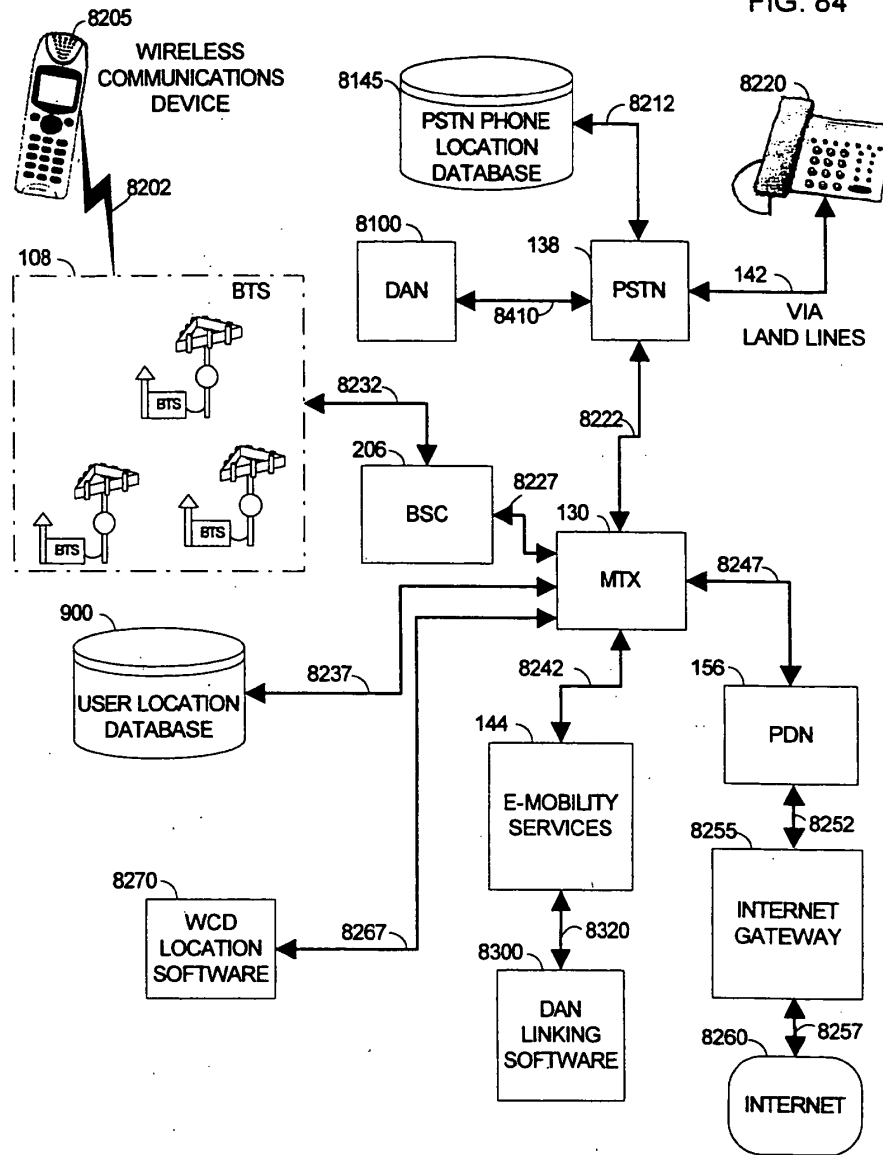

DAN LINKING SOFTWARE

FIG. 85

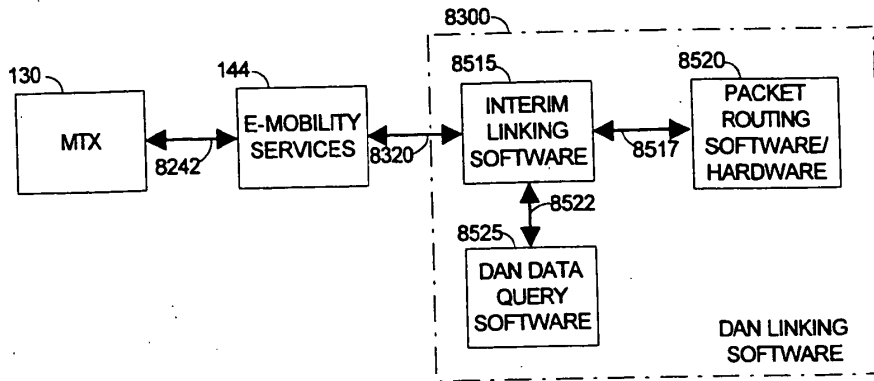

### Traffic Time Calculation Performance Based on Variable a

FIG. 86

$\beta := 2$      $b$  is equal to the amount of time it would take for vehicle to travel the geographic segment under normal conditions.

$a$  is an experimentally determined scaling factor

$Dr := 1$      $Dr$  is equal to the Density Ratio, which in the example is 3.

$$f(\alpha) := \alpha e^{Dr \cdot \beta}$$

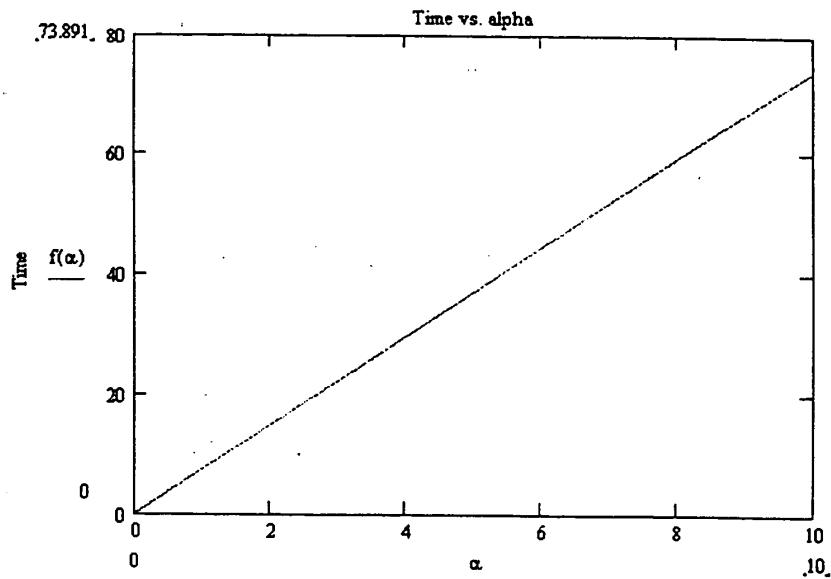



### Traffic Time Calculation Performance Based on Variable Traffic Density Ratio

FIG. 87

- $\beta = 1$        $b$  is equal to the amount of time it would take for vehicle to travel the geographic segment under normal conditions. It is 1 for this example.  
 $\alpha = 1$        $a$  is an experimentally determined scaling factor. It is 1 for this example  
 $D_r$  is equal to the Density Ratio, which in the example is 3.

$$f(D_r) := \alpha \cdot e^{D_r \cdot \beta}$$

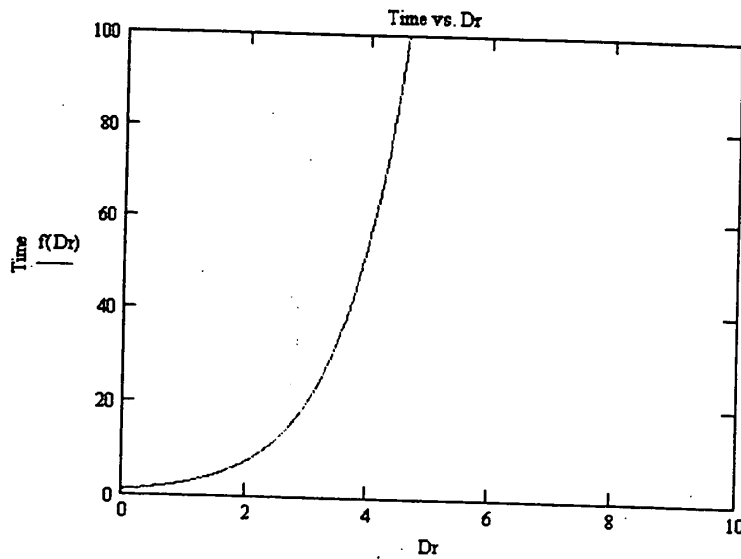

**USER LOCATION DATABASE  
COORDINATOR NETWORK  
(MARKET BASED SYSTEM)**

**FIG. 16**

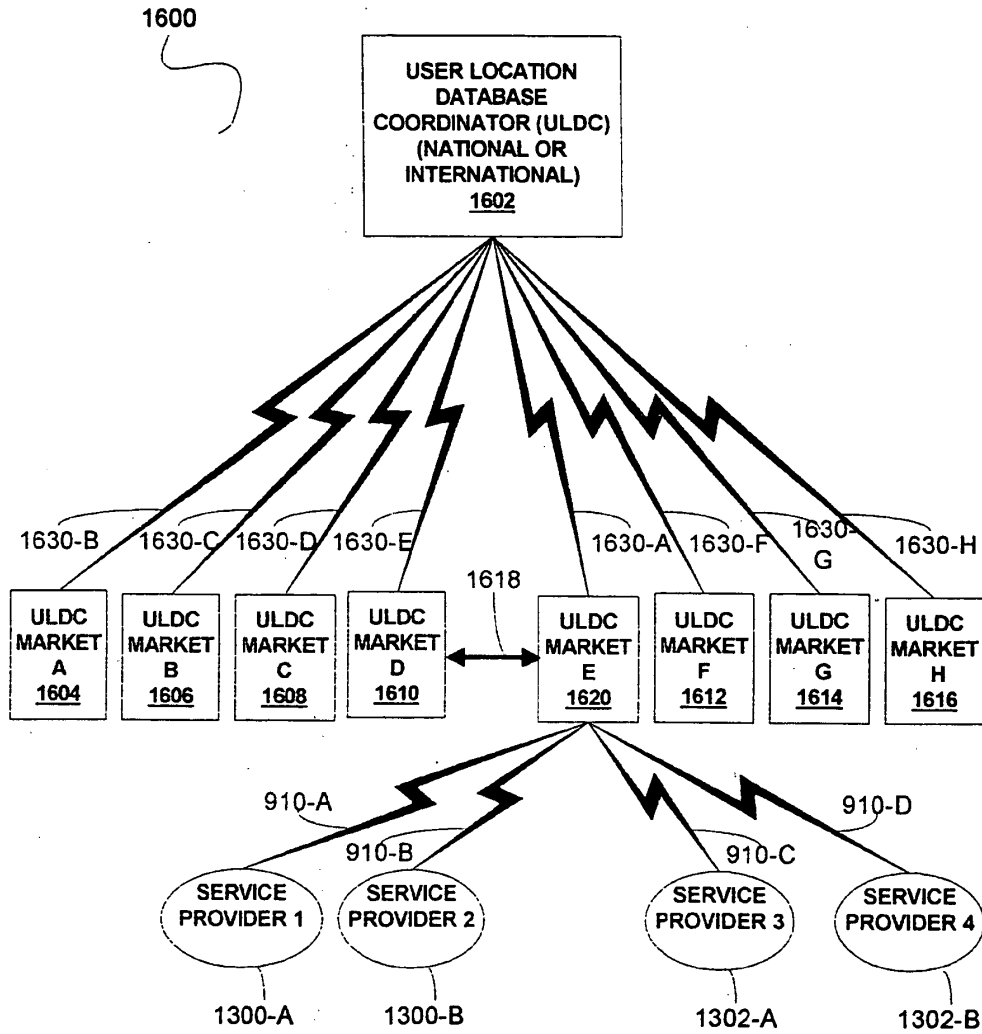

**DECLARATION (37 CFR 1.63) FOR UTILITY OR DESIGN APPLICATION USING AN APPLICATION DATA SHEET (37 CFR 1.76)**

<b>Title of Invention:</b>	<b>MACHINE FOR PROVIDING A DYNAMIC DATABASE OF GEOGRAPHIC LOCATION INFORMATION FOR A PLURALITY OF WIRELESS DEVICES AND PROCESS FOR MAKING SAME</b>
--------------------------------	--

As the below named inventor, I hereby declare that:

This declaration  
is directed to:

The attached application, or

United States application or PCT international application number  
14/642,408 filed on 03/09/2015.

The above-identified application was made or authorized to be made by me.

I believe that I am the original inventor or an original joint inventor of a claimed invention in the application.

I acknowledge the duty to disclose to the Patent and Trademark Office all information known to me to be material to patentability of the subject matter claimed in this application, as "materiality" is defined in 37 C.F.R. 1.56, which I understand includes information that is not cumulative to information already of record, or being made of record in the application, and that (1) establishes, by itself or in combination with other information, a prima facie case of unpatentability of a claim; or (2) refutes, or is inconsistent with, a position the applicant takes in: (i) opposing an argument of unpatentability relied on by the Patent Office, or (ii) asserting an argument of patentability.

I DECLARE THAT ALL STATEMENTS MADE OF MY OWN KNOWLEDGE ARE TRUE AND THAT ALL STATEMENTS MADE ON INFORMATION AND BELIEF ARE BELIEVED TO BE TRUE; AND FURTHER THAT THESE STATEMENTS WERE MADE WITH THE KNOWLEDGE THAT WILLFUL FALSE STATEMENTS AND THE LIKE SO MADE ARE PUNISHABLE BY FINE OR IMPRISONMENT, OR BOTH, UNDER SECTION 1001 OF TITLE 18 OF THE UNITED STATES CODE AND THAT SUCH WILLFUL FALSE STATEMENTS MAY JEOPARDIZE THE VALIDITY OF THE APPLICATION OR ANY PATENT ISSUED THEREON.

**LEGAL NAME OF INVENTOR**

Inventor: Mark Jefferson Reed

Date:

July 3<sup>rd</sup>, 2015

Signature:

Mark Jefferson Reed

Note: An application data sheet (PTO/SB/14 or equivalent), including naming the entire inventive entity, must accompany this form or must have been previously filed. Use an additional PTO/AIA/01 form for each additional inventor.

**DECLARATION (37 CFR 1.63) FOR UTILITY OR DESIGN APPLICATION USING AN APPLICATION DATA SHEET (37 CFR 1.76)**

Title of Invention:	MACHINE FOR PROVIDING A DYNAMIC DATABASE OF GEOGRAPHIC LOCATION INFORMATION FOR A PLURALITY OF WIRELESS DEVICES AND PROCESS FOR MAKING SAME
------------------------	---

As the below named inventor, I hereby declare that:

This declaration  
is directed to:

- The attached application, or
- United States application or PCT international application number 14/642,408 filed on 3/8/2015.

The above-identified application was made or authorized to be made by me.

I believe that I am the original inventor or an original joint inventor of a claimed invention in the application.

I acknowledge the duty to disclose to the Patent and Trademark Office all information known to me to be material to patentability of the subject matter claimed in this application, as "materiality" is defined in 37 C.F.R. 1.56, which I understand includes information that is not cumulative to information already of record, or being made of record in the application, and that (1) establishes, by itself or in combination with other information, a prima facie case of unpatentability of a claim; or (2) refutes, or is inconsistent with, a position the applicant takes in: (i) opposing an argument of unpatentability relied on by the Patent Office, or (ii) asserting an argument of patentability.

I DECLARE THAT ALL STATEMENTS MADE OF MY OWN KNOWLEDGE ARE TRUE AND THAT ALL STATEMENTS MADE ON INFORMATION AND BELIEF ARE BELIEVED TO BE TRUE; AND FURTHER THAT THESE STATEMENTS WERE MADE WITH THE KNOWLEDGE THAT WILLFUL FALSE STATEMENTS AND THE LIKE SO MADE ARE PUNISHABLE BY FINE OR IMPRISONMENT, OR BOTH, UNDER SECTION 1001 OF TITLE 18 OF THE UNITED STATES CODE AND THAT SUCH WILLFUL FALSE STATEMENTS MAY JEOPARDIZE THE VALIDITY OF THE APPLICATION OR ANY PATENT ISSUED THEREON.

**LEGAL NAME OF INVENTOR**

Inventor: Stephen Michael Palik Date: 8/2/2015

Signature: 

Note: An application data sheet (PTO/SB/14 or equivalent), including naming the entire inventive entity, must accompany this form or must have been previously filed. Use an additional PTO/ALA/01 form for each additional inventor.

Under the Paperwork Reduction Act of 1995, no persons are required to respond to a collection of information unless it contains a valid OMB control number.

<b>Application Data Sheet 37 CFR 1.76</b>		Attorney Docket Number	TX1000-C7
		Application Number	
Title of Invention	INTERNET QUERIED DIRECTIONAL NAVIGATION SYSTEM WITH MOBILE AND FIXED ORIGINATING LOCATION DETERMINATION		
The application data sheet is part of the provisional or nonprovisional application for which it is being submitted. The following form contains the bibliographic data arranged in a format specified by the United States Patent and Trademark Office as outlined in 37 CFR 1.76. This document may be completed electronically and submitted to the Office in electronic format using the Electronic Filing System (EFS) or the document may be printed and included in a paper filed application.			

**Secrecy Order 37 CFR 5.2:**

<input type="checkbox"/>	Portions or all of the application associated with this Application Data Sheet may fall under a Secrecy Order pursuant to 37 CFR 5.2 (Paper filers only. Applications that fall under Secrecy Order may not be filed electronically.)
--------------------------	---

**Inventor Information:**

Inventor	1				Remove
Legal Name					
Prefix	Given Name	Middle Name	Family Name	Suffix	
	Mark	Jefferson	Reed		
Residence Information (Select One) • US Residency Non US Residency Active US Military Service					
City	Tucson	State/Province	AZ	Country of Residence	US
Mailing Address of Inventor:					
Address 1	P.O. Box 13044				
Address 2					
City	Tucson	State/Province	AZ		
Postal Code	85732-3044	Country	US		
Inventor	2				Remove
Legal Name					
Prefix	Given Name	Middle Name	Family Name	Suffix	
	Stephen	Michael	Palik		
Residence Information (Select One) • US Residency Non US Residency Active US Military Service					
City	Redondo Beach	State/Province	CA	Country of Residence	US
Mailing Address of Inventor:					
Address 1	1700 Harper Ave.				
Address 2					
City	Redondo Beach	State/Province	CA		
Postal Code	90278	Country	US		
All Inventors Must Be Listed - Additional Inventor Information blocks may be generated within this form by selecting the Add button.					
Add					

**Correspondence Information:**

Enter either Customer Number or complete the Correspondence Information section below. For further information see 37 CFR 1.33(a).
---

Under the Paperwork Reduction Act of 1995, no persons are required to respond to a collection of information unless it contains a valid OMB control number.

<b>Application Data Sheet 37 CFR 1.76</b>		Attorney Docket Number	TX1000-C7
		Application Number	
Title of Invention	INTERNET QUERIED DIRECTIONAL NAVIGATION SYSTEM WITH MOBILE AND FIXED ORIGINATING LOCATION DETERMINATION		

An Address is being provided for the correspondence information of this application.

Customer Number	59911		
Email Address	mitch@harrispatent.com	<input type="button" value="Add Email"/>	<input type="button" value="Remove Email"/>

### Application Information:

Title of the Invention	INTERNET QUERIED DIRECTIONAL NAVIGATION SYSTEM WITH MOBILE AND FIXED ORIGINATING LOCATION DETERMINATION		
Attorney Docket Number	TX1000-C7	Small Entity Status Claimed	<input checked="" type="checkbox"/>
Application Type	Nonprovisional		
Subject Matter	Utility		
Total Number of Drawing Sheets (if any)	90	Suggested Figure for Publication (if any)	70

### Filing By Reference:

Only complete this section when filing an application by reference under 35 U.S.C. 111(c) and 37 CFR 1.57(a). Do not complete this section if application papers including a specification and any drawings are being filed. Any domestic benefit or foreign priority information must be provided in the appropriate section(s) below (i.e., "Domestic Benefit/National Stage Information" and "Foreign Priority Information").

For the purposes of a filing date under 37 CFR 1.53(b), the description and any drawings of the present application are replaced by this reference to the previously filed application, subject to conditions and requirements of 37 CFR 1.57(a).

Application number of the previously filed application	Filing date (YYYY-MM-DD)	Intellectual Property Authority or Country

### Publication Information:

Request Early Publication (Fee required at time of Request 37 CFR 1.219)

**Request Not to Publish.** I hereby request that the attached application not be published under 35 U.S.C. 122(b) and certify that the invention disclosed in the attached application **has not and will not** be the subject of an application filed in another country, or under a multilateral international agreement, that requires publication at eighteen months after filing.

### Representative Information:

Representative information should be provided for all practitioners having a power of attorney in the application. Providing this information in the Application Data Sheet does not constitute a power of attorney in the application (see 37 CFR 1.32). Either enter Customer Number or complete the Representative Name section below. If both sections are completed the customer Number will be used for the Representative Information during processing.

Please Select One:	<input checked="" type="radio"/> Customer Number	<input type="radio"/> US Patent Practitioner	<input type="radio"/> Limited Recognition (37 CFR 11.9)
Customer Number	59911		

<b>Application Data Sheet 37 CFR 1.76</b>		Attorney Docket Number	TX1000-C7
		Application Number	
Title of Invention	INTERNET QUERIED DIRECTIONAL NAVIGATION SYSTEM WITH MOBILE AND FIXED ORIGINATING LOCATION DETERMINATION		

### Domestic Benefit/National Stage Information:

This section allows for the applicant to either claim benefit under 35 U.S.C. 119(e), 120, 121, 365(c), or 386(c) or indicate National Stage entry from a PCT application. Providing benefit claim information in the Application Data Sheet constitutes the specific reference required by 35 U.S.C. 119(e) or 120, and 37 CFR 1.78.

When referring to the current application, please leave the "Application Number" field blank.

Prior Application Status	Pending					Remove
Application Number	Continuity Type	Prior Application Number	Filing or 371(c) Date (YYYY-MM-DD)			
	Continuation of	15468265	2017-03-24			
Prior Application Status	Patented					Remove
Application Number	Continuity Type	Prior Application Number	Filing Date (YYYY-MM-DD)	Patent Number	Issue Date (YYYY-MM-DD)	
15468265	Continuation of	15297222	2016-10-19	9642024	2017-05-02	
Prior Application Status	Patented					Remove
Application Number	Continuity Type	Prior Application Number	Filing Date (YYYY-MM-DD)	Patent Number	Issue Date (YYYY-MM-DD)	
15297222	Continuation of	14642408	2015-03-09	9510320	2016-11-29	
Prior Application Status	Patented					Remove
Application Number	Continuity Type	Prior Application Number	Filing Date (YYYY-MM-DD)	Patent Number	Issue Date (YYYY-MM-DD)	
14642408	Continuation of	11505578	2006-08-17	8977284	2015-03-10	
Prior Application Status	Abandoned					Remove
Application Number	Continuity Type	Prior Application Number	Filing or 371(c) Date (YYYY-MM-DD)			
11505578	Continuation in part of	10255552	2002-09-24			
Prior Application Status	Expired					Remove
Application Number	Continuity Type	Prior Application Number	Filing or 371(c) Date (YYYY-MM-DD)			
10255552	Claims benefit of provisional	60327327	2001-10-04			
Prior Application Status	Expired					Remove
Application Number	Continuity Type	Prior Application Number	Filing or 371(c) Date (YYYY-MM-DD)			
10255552	Claims benefit of provisional	60383528	2002-05-28			
Prior Application Status	Expired					Remove
Application Number	Continuity Type	Prior Application Number	Filing or 371(c) Date (YYYY-MM-DD)			
10255552	Claims benefit of provisional	60352761	2002-01-29			

Under the Paperwork Reduction Act of 1995, no persons are required to respond to a collection of information unless it contains a valid OMB control number.

<b>Application Data Sheet 37 CFR 1.76</b>		Attorney Docket Number	TX1000-C7
		Application Number	
Title of Invention	INTERNET QUERIED DIRECTIONAL NAVIGATION SYSTEM WITH MOBILE AND FIXED ORIGINATING LOCATION DETERMINATION		
Prior Application Status	Expired	<input type="button" value="Remove"/>	
Application Number	Continuity Type	Prior Application Number	Filing or 371(c) Date (YYYY-MM-DD)
10255552	Claims benefit of provisional	60335203	2001-10-23
Prior Application Status	Expired	<input type="button" value="Remove"/>	
Application Number	Continuity Type	Prior Application Number	Filing or 371(c) Date (YYYY-MM-DD)
10255552	Claims benefit of provisional	60383529	2002-05-28
Prior Application Status	Expired	<input type="button" value="Remove"/>	
Application Number	Continuity Type	Prior Application Number	Filing or 371(c) Date (YYYY-MM-DD)
10255552	Claims benefit of provisional	60391469	2002-06-26
Prior Application Status	Expired	<input type="button" value="Remove"/>	
Application Number	Continuity Type	Prior Application Number	Filing or 371(c) Date (YYYY-MM-DD)
10255552	Claims benefit of provisional	60353379	2002-01-30
Prior Application Status	Expired	<input type="button" value="Remove"/>	
Application Number	Continuity Type	Prior Application Number	Filing or 371(c) Date (YYYY-MM-DD)
10255552	Claims benefit of provisional	60381249	2002-05-16
Additional Domestic Benefit/National Stage Data may be generated within this form by selecting the <b>Add</b> button.			<input type="button" value="Add"/>

**Foreign Priority Information:**

This section allows for the applicant to claim priority to a foreign application. Providing this information in the application data sheet constitutes the claim for priority as required by 35 U.S.C. 119(b) and 37 CFR 1.55. When priority is claimed to a foreign application that is eligible for retrieval under the priority document exchange program (PDX)<sup>i</sup> the information will be used by the Office to automatically attempt retrieval pursuant to 37 CFR 1.55(i)(1) and (2). Under the PDX program, applicant bears the ultimate responsibility for ensuring that a copy of the foreign application is received by the Office from the participating foreign intellectual property office, or a certified copy of the foreign priority application is filed, within the time period specified in 37 CFR 1.55(g)(1).

Application Number	Country <sup>i</sup>	Filing Date (YYYY-MM-DD)	Access Code <sup>i</sup> (if applicable)	<input type="button" value="Remove"/>
Additional Foreign Priority Data may be generated within this form by selecting the <b>Add</b> button.				<input type="button" value="Add"/>



Under the Paperwork Reduction Act of 1995, no persons are required to respond to a collection of information unless it contains a valid OMB control number.

<b>Application Data Sheet 37 CFR 1.76</b>	Attorney Docket Number	TX1000-C7
	Application Number	
Title of Invention	INTERNET QUERIED DIRECTIONAL NAVIGATION SYSTEM WITH MOBILE AND FIXED ORIGINATING LOCATION DETERMINATION	

### Statement under 37 CFR 1.55 or 1.78 for AIA (First Inventor to File) Transition Applications

<p>This application (1) claims priority to or the benefit of an application filed before March 16, 2013 and (2) also contains, or contained at any time, a claim to a claimed invention that has an effective filing date on or after March 16, 2013.</p> <p><input type="checkbox"/> NOTE: By providing this statement under 37 CFR 1.55 or 1.78, this application, with a filing date on or after March 16, 2013, will be examined under the first inventor to file provisions of the AIA.</p>
--

<b>Application Data Sheet 37 CFR 1.76</b>	Attorney Docket Number	TX1000-C7
	Application Number	
Title of Invention	INTERNET QUERIED DIRECTIONAL NAVIGATION SYSTEM WITH MOBILE AND FIXED ORIGINATING LOCATION DETERMINATION	

## Authorization or Opt-Out of Authorization to Permit Access:

When this Application Data Sheet is properly signed and filed with the application, applicant has provided written authority to permit a participating foreign intellectual property (IP) office access to the instant application-as-filed (see paragraph A in subsection 1 below) and the European Patent Office (EPO) access to any search results from the instant application (see paragraph B in subsection 1 below).

Should applicant choose not to provide an authorization identified in subsection 1 below, applicant **must opt-out** of the authorization by checking the corresponding box A or B or both in subsection 2 below.

**NOTE:** This section of the Application Data Sheet is **ONLY** reviewed and processed with the **INITIAL** filing of an application. After the initial filing of an application, an Application Data Sheet cannot be used to provide or rescind authorization for access by a foreign IP office(s). Instead, Form PTO/SB/39 or PTO/SB/69 must be used as appropriate.

### 1. Authorization to Permit Access by a Foreign Intellectual Property Office(s)

**A. Priority Document Exchange (PDX)** - Unless box A in subsection 2 (opt-out of authorization) is checked, the undersigned hereby **grants the USPTO authority** to provide the European Patent Office (EPO), the Japan Patent Office (JPO), the Korean Intellectual Property Office (KIPO), the State Intellectual Property Office of the People's Republic of China (SIPO), the World Intellectual Property Organization (WIPO), and any other foreign intellectual property office participating with the USPTO in a bilateral or multilateral priority document exchange agreement in which a foreign application claiming priority to the instant patent application is filed, access to: (1) the instant patent application-as-filed and its related bibliographic data, (2) any foreign or domestic application to which priority or benefit is claimed by the instant application and its related bibliographic data, and (3) the date of filing of this Authorization. See 37 CFR 1.14(h) (1).

**B. Search Results from U.S. Application to EPO** - Unless box B in subsection 2 (opt-out of authorization) is checked, the undersigned hereby **grants the USPTO authority** to provide the EPO access to the bibliographic data and search results from the instant patent application when a European patent application claiming priority to the instant patent application is filed. See 37 CFR 1.14(h)(2).

The applicant is reminded that the EPO's Rule 141(1) EPC (European Patent Convention) requires applicants to submit a copy of search results from the instant application without delay in a European patent application that claims priority to the instant application.

### 2. Opt-Out of Authorizations to Permit Access by a Foreign Intellectual Property Office(s)

A. Applicant **DOES NOT** authorize the USPTO to permit a participating foreign IP office access to the instant application-as-filed. If this box is checked, the USPTO will not be providing a participating foreign IP office with any documents and information identified in subsection 1A above.

B. Applicant **DOES NOT** authorize the USPTO to transmit to the EPO any search results from the instant patent application. If this box is checked, the USPTO will not be providing the EPO with search results from the instant application.

**NOTE:** Once the application has published or is otherwise publicly available, the USPTO may provide access to the application in accordance with 37 CFR 1.14.

<b>Application Data Sheet 37 CFR 1.76</b>	Attorney Docket Number	TX1000-C7
	Application Number	
Title of Invention	INTERNET QUERIED DIRECTIONAL NAVIGATION SYSTEM WITH MOBILE AND FIXED ORIGINATING LOCATION DETERMINATION	

## Applicant Information:

Providing assignment information in this section does not substitute for compliance with any requirement of part 3 of Title 37 of CFR to have an assignment recorded by the Office.			
<b>Applicant</b>	<b>1</b>	<input type="button" value="Remove"/>	
If the applicant is the inventor (or the remaining joint inventor or inventors under 37 CFR 1.45), this section should not be completed. The information to be provided in this section is the name and address of the legal representative who is the applicant under 37 CFR 1.43; or the name and address of the assignee, person to whom the inventor is under an obligation to assign the invention, or person who otherwise shows sufficient proprietary interest in the matter who is the applicant under 37 CFR 1.46. If the applicant is an applicant under 37 CFR 1.46 (assignee, person to whom the inventor is obligated to assign, or person who otherwise shows sufficient proprietary interest) together with one or more joint inventors, then the joint inventor or inventors who are also the applicant should be identified in this section.			
<input type="button" value="Clear"/>			
<input checked="" type="radio"/> Assignee	Legal Representative under 35 U.S.C. 117	Joint Inventor	
Person to whom the inventor is obligated to assign.		Person who shows sufficient proprietary interest	
If applicant is the legal representative, indicate the authority to file the patent application, the inventor is:			
▼			
Name of the Deceased or Legally Incapacitated Inventor: <input type="text"/>			
If the Applicant is an Organization check here. <input checked="" type="checkbox"/>			
Organization Name	<input type="text" value="Traxcell Technologies, LLC"/>		
<b>Mailing Address Information For Applicant:</b>			
Address 1	<input type="text" value="1405 Municipal Ave., Suite 2305"/>		
Address 2	<input type="text"/>		
City	<input type="text" value="Plano"/>	State/Province	<input type="text" value="TX"/>
Country	<input type="text" value="US"/>	Postal Code	<input type="text" value="75074"/>
Phone Number	<input type="text"/>	Fax Number	<input type="text"/>
Email Address	<input type="text"/>		
Additional Applicant Data may be generated within this form by selecting the Add button. <input type="button" value="Add"/>			

## Assignee Information including Non-Applicant Assignee Information:

Providing assignment information in this section does not substitute for compliance with any requirement of part 3 of Title 37 of CFR to have an assignment recorded by the Office.

Under the Paperwork Reduction Act of 1995, no persons are required to respond to a collection of information unless it contains a valid OMB control number.

<b>Application Data Sheet 37 CFR 1.76</b>		Attorney Docket Number	TX1000-C7
		Application Number	
Title of Invention	INTERNET QUERIED DIRECTIONAL NAVIGATION SYSTEM WITH MOBILE AND FIXED ORIGINATING LOCATION DETERMINATION		

<b>Assignee</b>	1
-----------------	---

Complete this section if assignee information, including non-applicant assignee information, is desired to be included on the patent application publication. An assignee-applicant identified in the "Applicant Information" section will appear on the patent application publication as an applicant. For an assignee-applicant, complete this section only if identification as an assignee is also desired on the patent application publication.

Remove

If the Assignee or Non-Applicant Assignee is an Organization check here. 

Prefix	Given Name	Middle Name	Family Name	Suffix

**Mailing Address Information For Assignee including Non-Applicant Assignee:**

Address 1				
Address 2				
City		State/Province		
Country i		Postal Code		
Phone Number		Fax Number		
Email Address				

Additional Assignee or Non-Applicant Assignee Data may be generated within this form by selecting the Add button.

Add

**Signature:**

Remove

**NOTE:** This Application Data Sheet must be signed in accordance with 37 CFR 1.33(b). However, if this Application Data Sheet is submitted with the **INITIAL** filing of the application and either box A or B is **not** checked in subsection 2 of the "Authorization or Opt-Out of Authorization to Permit Access" section, then this form must also be signed in accordance with 37 CFR 1.14(c).

This Application Data Sheet **must** be signed by a patent practitioner if one or more of the applicants is a **juristic entity** (e.g., corporation or association). If the applicant is two or more joint inventors, this form must be signed by a patent practitioner, **all** joint inventors who are the applicant, or one or more joint inventor-applicants who have been given power of attorney (e.g., see USPTO Form PTO/AIA/81) on behalf of **all** joint inventor-applicants.

See 37 CFR 1.4(d) for the manner of making signatures and certifications.

<b>Signature</b>	/Andrew Mitchell Harris #42,638/		Date (YYYY-MM-DD)	2017-09-27	
First Name	Andrew	Last Name	Harris	Registration Number	42638

Additional Signature may be generated within this form by selecting the Add button.

Add

Under the Paperwork Reduction Act of 1995, no persons are required to respond to a collection of information unless it contains a valid OMB control number.

<b>Application Data Sheet 37 CFR 1.76</b>		Attorney Docket Number	TX1000-C7
		Application Number	
Title of Invention	INTERNET QUERIED DIRECTIONAL NAVIGATION SYSTEM WITH MOBILE AND FIXED ORIGINATING LOCATION DETERMINATION		

This collection of information is required by 37 CFR 1.76. The information is required to obtain or retain a benefit by the public which is to file (and by the USPTO to process) an application. Confidentiality is governed by 35 U.S.C. 122 and 37 CFR 1.14. This collection is estimated to take 23 minutes to complete, including gathering, preparing, and submitting the completed application data sheet form to the USPTO. Time will vary depending upon the individual case. Any comments on the amount of time you require to complete this form and/or suggestions for reducing this burden, should be sent to the Chief Information Officer, U.S. Patent and Trademark Office, U.S. Department of Commerce, P.O. Box 1450, Alexandria, VA 22313-1450. DO NOT SEND FEES OR COMPLETED FORMS TO THIS ADDRESS. **SEND TO: Commissioner for Patents, P.O. Box 1450, Alexandria, VA 22313-1450.**

## Privacy Act Statement

The Privacy Act of 1974 (P.L. 93-579) requires that you be given certain information in connection with your submission of the attached form related to a patent application or patent. Accordingly, pursuant to the requirements of the Act, please be advised that: (1) the general authority for the collection of this information is 35 U.S.C. 2(b)(2); (2) furnishing of the information solicited is voluntary; and (3) the principal purpose for which the information is used by the U.S. Patent and Trademark Office is to process and/or examine your submission related to a patent application or patent. If you do not furnish the requested information, the U.S. Patent and Trademark Office may not be able to process and/or examine your submission, which may result in termination of proceedings or abandonment of the application or expiration of the patent.

The information provided by you in this form will be subject to the following routine uses:

1. The information on this form will be treated confidentially to the extent allowed under the Freedom of Information Act (5 U.S.C. 552) and the Privacy Act (5 U.S.C. 552a). Records from this system of records may be disclosed to the Department of Justice to determine whether the Freedom of Information Act requires disclosure of these records.
2. A record from this system of records may be disclosed, as a routine use, in the course of presenting evidence to a court, magistrate, or administrative tribunal, including disclosures to opposing counsel in the course of settlement negotiations.
3. A record in this system of records may be disclosed, as a routine use, to a Member of Congress submitting a request involving an individual, to whom the record pertains, when the individual has requested assistance from the Member with respect to the subject matter of the record.
4. A record in this system of records may be disclosed, as a routine use, to a contractor of the Agency having need for the information in order to perform a contract. Recipients of information shall be required to comply with the requirements of the Privacy Act of 1974, as amended, pursuant to 5 U.S.C. 552a(m).
5. A record related to an International Application filed under the Patent Cooperation Treaty in this system of records may be disclosed, as a routine use, to the International Bureau of the World Intellectual Property Organization, pursuant to the Patent Cooperation Treaty.
6. A record in this system of records may be disclosed, as a routine use, to another federal agency for purposes of National Security review (35 U.S.C. 181) and for review pursuant to the Atomic Energy Act (42 U.S.C. 218(c)).
7. A record from this system of records may be disclosed, as a routine use, to the Administrator, General Services, or his/her designee, during an inspection of records conducted by GSA as part of that agency's responsibility to recommend improvements in records management practices and programs, under authority of 44 U.S.C. 2904 and 2906. Such disclosure shall be made in accordance with the GSA regulations governing inspection of records for this purpose, and any other relevant (i.e., GSA or Commerce) directive. Such disclosure shall not be used to make determinations about individuals.
8. A record from this system of records may be disclosed, as a routine use, to the public after either publication of the application pursuant to 35 U.S.C. 122(b) or issuance of a patent pursuant to 35 U.S.C. 151. Further, a record may be disclosed, subject to the limitations of 37 CFR 1.14, as a routine use, to the public if the record was filed in an application which became abandoned or in which the proceedings were terminated and which application is referenced by either a published application, an application open to public inspections or an issued patent.
9. A record from this system of records may be disclosed, as a routine use, to a Federal, State, or local law enforcement agency, if the USPTO becomes aware of a violation or potential violation of law or regulation.

Substitute for form 1449/PTO  <b>INFORMATION DISCLOSURE                  STATEMENT BY APPLICANT</b>	<b>Complete if Known</b>
	Application Number    --Unknown--
	Filing Date                --Submitted herewith--
	First Named Inventor    Reed
	Examiner Name            -- Unknown --
	Art Unit                    -- Unknown --
	Attorney Docket No.    TX1000-C7

Examiner Initials	Document Number	Publication Date MM-DD-YYYY	Name of Patentee or Applicant of Cited Document	Pages, Columns, Lines, Where Relevant Passages or Relevant Figures Appear
	US-20170195847-A1	07-06-2017	Reed, et al.	
	US-9,642,024-B2	05-02-2017	Reed, et al.	
	US-20160227510-A1	04-15-2016	Reed, et al.	
	US-20150312882-A1	10-29-2015	Reed, et al.	
	US-8,977,284-B2	03-10-2015	Reed	
	US-20030134648-A1	07-17-2003	Reed	
	US-6,845,246-B1	01-18-2005	Steer	
	US-6,931,256-B2	08-16-2005	Mandyam	
	US-6,334,047-B1	12-25-2001	Andersson, et al.	
	US-7,689,240-B2	03-30-2010	Anderson	
	US-7,120,392-B2	10-10-2006	Chu, et al.	
	US-6,157,838	12-05-2000	Di Huo, et al.	
	US-7,574,230-B1	08-11-2009	Oh, et al.	
	US-6,298,306-B1	10-02-2001	Suarez, et al.	
	US-7,634,266-B2	12-15-2009	McDougall, et al.	
	US-6,751,443-B2	06-15-2004	Haymes, et al.	
	US-7,333,820-B2	02-19-2008	Sheha, et al.	
	US-8,218,507-B2	07-10-2012	Palmer, et al.	
	US-7,853,267-B2	12-14-2010	Jensen	
	US-6,901,264	05-31-2005	Myr	
	US-3,419,865	12-31-1968	Chisholm	
	US-4,494,119	01-15-1985	Wimbush	
	US-5,873,040	02-16-1999	Dunn, et al.	
	US-5,930,515	07-27-1999	Ducharme, et al.	
	US-6,308,073-B1	10-23-2001	Petty, et al.	
	US-7,366,522-B2	04-29-2008	Thomas	
	US-6,799,049-B1	09-28-2004	Zellner, et al.	
	US-5,479,482	12-26-1995	Grimes	
	US-6,603,977-B1	08-05-2003	Walsh, et al.	
	US-6,816,720-B2	11-09-2004	Hussain, et al.	
	US-6,839,552-B1	01-04-2005	Martin	
	US-4,818,998	04-04-1989	Apsell, et al.	

Examiner:

Date Considered:

EXAMINER: Initial if reference considered, whether or not citation is in conformance with MPEP 609; Draw line through citation if not in conformance and not considered. Include copy of this form with next communication to applicant.

Substitute for form 1449/PTO  <b>INFORMATION DISCLOSURE STATEMENT BY APPLICANT</b>	<b>Complete if Known</b>
	Application Number    --Unknown--
	Filing Date            --Submitted herewith--
	First Named Inventor    Reed
	Examiner Name         -- Unknown --
	Art Unit                -- Unknown --
	Attorney Docket No.    TX1000-C7

Examiner Initials	Document Number	Publication Date MM-DD-YYYY	Name of Patentee or Applicant of Cited Document	Pages, Columns, Lines, Where Relevant Passages or Relevant Figures Appear
	US-4,908,629	03-13-1990	Apsell, et al.	
	US-4,891,650	01-02-1990	Sheffer	
	US-6,249,252-B1	06-19-2001	Dupray	
	US-6,249,680-B1	06-19-2001	Wax, et al.	
	US-6,167,275	12-26-2000	Oros, et al.	
	US-6,091,956	07-18-2000	Hollenberg	
	US-6,633,761-B1	10-14-2003	Singhal, et al.	
	US-5,561,704	10-01-1996	Salimando	
	US-5,694,335	12-02-1997	Hollenberg	
	US-6,150,961	11-21-2000	Alewine, et al.	
	US-20150309295-A1	10-29-2015	Cocker, et al.	
	US-7,082,365-B2	07-25-2006	Sheha, et al.	
	US-20020052786-A1	05-02-2002	Kim, et al.	
	US-5,933,100	08-03-1999	Golding	
	US-6,052,598	04-18-2000	Rudrapatna, et al.	
	US-6,362,783-B1	03-26-2002	Sigiura, et al.	
	US-6,505,114-B2	01-07-2003	Luciani	
	US-6,314,365-B1	11-06-2001	Smith	
	US-6,490,521-B2	12-03-2002	Wiener	
	US-6,401,035-B2	06-04-2002	Jin	
	US-6,654,683-B2	11-25-2003	Jin, et al.	
	US-7,389,179-B2	06-17-2008	Jin, et al.	
	US-6,151,505	11-21-2000	Larkins, et al.	
	US-6,292,743-B1	09-18-2001	Pu, et al.	
	US-6,111,539	08-29-2000	Mannings, et al.	
	US-5,504,482	04-02-1996	Schreder	
	US-5,712,899	01-27-1998	Pace, II	
	US-6,295,502-B1	09-25-2001	Hancock, et al.	
	US-6,542,816-B1	04-01-2003	Ito, et al.	
	US-5,959,577	09-28-1999	Fan, et al.	
	US-6,088,594	07-11-2000	Kingdon, et al.	
	US-6,677,894-B2	01-13-2004	Sheynblat, et al.	

Examiner: \_\_\_\_\_

Date Considered: \_\_\_\_\_

EXAMINER: Initial if reference considered, whether or not citation is in conformance with MPEP 609; Draw line through citation if not in conformance and not considered. Include copy of this form with next communication to applicant.



Substitute for form 1449/PTO  <b>INFORMATION DISCLOSURE                  STATEMENT BY APPLICANT</b>	<b>Complete if Known</b>
	Application Number    --Unknown--
	Filing Date            --Submitted herewith--
	First Named Inventor    Reed
	Examiner Name         -- Unknown --
	Art Unit                -- Unknown --
	Attorney Docket No.    TX1000-C7

Examiner Initials	Document Number	Publication Date MM-DD-YYYY	Name of Patentee or Applicant of Cited Document	Pages, Columns, Lines, Where Relevant Passages or Relevant Figures Appear
	US-6,243,030-B1	06-05-2001	Levine	
	US-6,442,394-B1	08-27-2002	Valentine, et al.	
	US-6,950,745-B2	09-27-2005	Agnew, et al.	
	US-6,853,915-B2	02-08-2005	Hubschneider, et al.	
	US-5,911,773	06-15-1999	Mutsuga, et al.	
	US-6,163,751	12-19-2000	Van Roekel	
	US-6,278,941-B1	08-21-2001	Yokoyama	
	US-6,341,255-B1	01-22-2002	Lapidot	
	US-7,260,473-B2	08-21-2007	Abe, et al.	
	US-6,421,607-B1	07-16-2002	Gee, et al.	
	US-7,117,085-B2	10-03-2006	Buecher, et al.	
	US-6,317,684-B1	11-13-2001	Roeseler, et al.	
	US-6,484,093-B1	11-19-2002	Ito, et al.	
	US-6,282,491-B1	08-28-2001	Bochmann, et al.	
	US-5,543,789	08-06-1996	Behr, et al.	
	US-5,839,086	11-17-1998	Hirano	
	US-6,336,073-B1	01-01-2002	Ihara, et al.	
	US-6,725,155-B1	04-20-2004	Takahashi, et al.	
	US-6,662,105-B1	12-09-2003	Tada, et al.	
	US-6,847,889-B2	01-25-2005	Park, et al.	
	US-6,614,363-B1	09-02-2003	Behr, et al.	
	US-6,084,955	07-04-2000	Key, et al.	
	US-6,266,514-B1	07-24-2001	O'Donnell	
	US-7,280,803-B2	10-09-2007	Nelson	
	US-6,782,256-B2	08-24-2004	Engholm, et al.	
	US-6,317,605-B1	11-13-2001	Sakuma	
	US-7,333,794-B2	02-19-2008	Zappala	
	US-6,985,839-B1	01-10-2006	Motamedi, et al.	
	US-7,116,990-B2	10-03-2006	Maanoja	
	US-20050043036-A1	02-24-2005	Ioppe, et al.	
	US-7,203,503-B2	04-10-2007	Cedervall, et al.	
	US-6,907,252-B2	06-14-2005	Papadias, et al.	

Examiner: \_\_\_\_\_

Date Considered: \_\_\_\_\_

EXAMINER: Initial if reference considered, whether or not citation is in conformance with MPEP 609; Draw line through citation if not in conformance and not considered. Include copy of this form with next communication to applicant.

Substitute for form 1449/PTO  <b>INFORMATION DISCLOSURE                  STATEMENT BY APPLICANT</b>	<b>Complete if Known</b>
	Application Number    --Unknown--
	Filing Date                --Submitted herewith--
	First Named Inventor    Reed
	Examiner Name            -- Unknown --
	Art Unit                    -- Unknown --
	Attorney Docket No.    TX1000-C7

Examiner Initials	Document Number	Publication Date MM-DD-YYYY	Name of Patentee or Applicant of Cited Document	Pages, Columns, Lines, Where Relevant Passages or Relevant Figures Appear
	US-7,996,017-B2	08-09-2011	Vanttinen	
	US-7,151,940-B2	12-19-2006	Vanttinen, et al.	
	US-6,526,283-B1	02-25-2003	Jang	
	US-7,574,222-B2	08-11-2009	Sawada, et al.	
	US-6,721,542-B1	04-13-2004	Anttila, et al.	
	US-7,149,201-B2	12-12-2006	Hunzinger	
	US-7,024,187-B2	04-04-2006	Moles, et al.	
	US-6,298,233-B1	10-02-2001	Souissi, et al.	
	US-6,925,300-B2	08-02-2005	Horne	
	US-6,073,075	06-06-2000	Kondou	
	US-6,941,220-B2	09-06-2005	Le, et al.	
	US-7,162,367-B2	01-09-2007	Lin, et al.	
	US-20030199260-A1	10-23-2003	Casey, et al.	
	US-20040246147-A1	12-09-2004	Von Grabe	
	US-7,164,921-B2	01-16-2007	Owens, et al.	
	US-6,456,854-B1	09-24-2002	Chern, et al.	
	US-6,944,447-B2	09-13-2005	Portman, et al.	
	US-20020002504-A1	01-03-2002	Engel, et al.	
	US-5,835,061	11-10-1998	Stewart	
	US-6,650,902-B1	11-18-2003	Richton	
	US-6,836,667-B1	12-28-2004	Smith, Jr.	
	US-7,024,205-B1	04-04-2006	Hose	
	US-7,076,244-B2	07-11-2006	Lazaridis, et al.	
	US-20030004743-A1	01-02-2003	Callegari	
	US-20020161633-A1	10-31-2002	Jacob, et al.	
	US-7,103,368-B2	09-05-2006	Teshima	
	US-7,813,741-B2	10-12-2010	Hendrey, et al.	
	US-20020091568-A1	07-11-2002	Kraft, et al.	
	US-6,798,358-B2	09-28-2004	Joyce, et al.	
	US-20020111154-A1	08-15-2002	Eldering, et al.	
	US-7,089,264-B1	08-08-2006	Guido, et al.	

Examiner:

Date Considered:

EXAMINER: Initial if reference considered, whether or not citation is in conformance with MPEP 609; Draw line through citation if not in conformance and not considered. Include copy of this form with next communication to applicant.

Substitute for form 1449/PTO  <b>INFORMATION DISCLOSURE                  STATEMENT BY APPLICANT</b>	<b>Complete if Known</b>
	Application Number    --Unknown--
	Filing Date            --Submitted herewith--
	First Named Inventor    Reed
	Examiner Name         -- Unknown --
	Art Unit                -- Unknown --
	Attorney Docket No.    TX1000-C7

Examiner Initials	Document Number	Publication Date MM-DD-YYYY	Name of Patentee or Applicant of Cited Document	Pages, Columns, Lines, Where Relevant Passages or Relevant Figures Appear
	US-6,795,710-B1	09-21-2004	Creemer	
	US-6,157,841	12-05-2000	Bolduc, et al.	
	US-6,580,914-B1	06-17-2003	Smith	
	US-6,014,090	01-11-2000	Rosen, et al.	
	US-6,970,922-B1	11-29-2005	Spector	
	US-6,492,944-B1	12-10-2002	Stilp	
	US-5,519,760	05-21-1996	Borkowski, et al.	
	US-6,321,092-B1	11-20-2001	Fitch, et al.	
	US-6,456,852-B2	09-24-2002	Bar, et al.	
	US-6,317,604-B1	11-13-2001	Kovach, Jr., et al.	
	US-6,952,181-B2	10-04-2005	Karr, et al.	
	US-6,236,365-B1	05-22-2001	LeBlanc, et al.	
	US-6,961,562-B2	11-01-2005	Ross	
	US-7,123,918-B1	10-17-2006	Goodman	
	US-20040093289-A1	05-13-2004	Bodin	
	US-6,557,139-B2	04-29-2003	Bohnke	
	US-6,233,449-B1	05-15-2001	Glitho, et al.	
	US-7,689,240-B2	03-30-2010	Anderson	
	US-6,839,554-B2	01-04-2005	McDowell, et al.	
	US-20020035605-A1	03-21-2002	McDowell, et al.	
	US-7,546,128-B2	06-09-2009	Smith, et al.	
	US-6,842,620-B2	01-11-2005	Smith, et al.	
	US-5,588,048	12-24-1996	Neville	
	US-20030003900-A1	01-02-2003	Goss, et al.	
	US-7,616,950-B2	11-10-2009	Pearson, et al.	
	US-8,862,106-B2	10-14-2014	Salisbury, et al.	
	US-RE42,937 E	11-15-2011	Want, et al.	
	US-6,847,969-B1	01-25-2005	Mathai, et al.	
	US-6,671,646-B2	12-30-2003	Manegold, et al.	
	US-7,808,369-B2	10-05-2010	Brinton, et al.	

Examiner:

Date Considered:

EXAMINER: Initial if reference considered, whether or not citation is in conformance with MPEP 609; Draw line through citation if not in conformance and not considered. Include copy of this form with next communication to applicant.

Substitute for form 1449/PTO  <b>INFORMATION DISCLOSURE                  STATEMENT BY APPLICANT</b>	<b>Complete if Known</b>
	Application Number    --Unknown--
	Filing Date                --Submitted herewith--
	First Named Inventor    Reed
	Examiner Name            -- Unknown --
	Art Unit                    -- Unknown --
	Attorney Docket No.    TX1000-C7

Examiner Initials	Document Number	Publication Date MM-DD-YYYY	Name of Patentee or Applicant of Cited Document	Pages, Columns, Lines, Where Relevant Passages or Relevant Figures Appear
	US-7,564,375-B2	07-21-2009	Brinton, et al.	
	US-7,362,229-B2	04-22-2008	Brinton, et al.	
	US-7,557,696-B2	07-07-2009	Brinton, et al.	
	US-6,804,626-B2	10-12-2004	Manegold, et al.	
	US-7,117,121-B2	10-03-2006	Brinton, et al.	
	US-5,272,638	12-21-1993	Martin, et al.	
	US-5,465,289	11-07-1995	Kennedy, Jr.	
	US-5,745,865	04-28-1998	Rostoker, et al.	
	US-6,343,290-B1	01-29-2002	Cossins, et al.	
	US-5,844,522	12-01-1998	Sheffer, et al.	
	US-5,987,329	11-16-1999	Yost, et al.	
	US-5,930,717	07-27-1999	Yost, et al.	
	US-6,539,229-B1	03-25-2003	Ali	
	US-6,662,023-B1	12-09-2003	Helle	
	US-6,225,944-B1	05-01-2001	Hayes	
	US-6,246,861-B1	06-12-2001	Messier, et al.	
	US-6,097,336	08-01-2000	Stilp	
	US-6,385,458-B1	05-07-2002	Papadimitriou, et al.	
	US-7,519,372-B2	04-14-2009	MacDonald, et al.	
	US-6,243,588-B1	06-05-2001	Koorapaty, et al.	
	US-5,524,136	06-04-1996	Bar-Noy, et al.	
	US-6,674,403-B2	01-06-2004	Gray, et al.	
	US-20020169539-A1	11-14-2002	Menard, et al.	
	US-5,890,068	03-30-1999	Fattouche, et al.	
	US-6,330,452-B1	12-11-2001	Fattouche, et al.	
	US-7,130,630-B1	10-31-2006	Enzmann, et al.	
	US-7,133,909-B2	11-07-2006	Bahl	
	US-6,236,335-B1	05-22-2001	Goodwin, III	
	US-6,716,101-B1	04-06-2004	Meadows, et al.	
	US-7,525,484-B2	04-28-2009	Dupray, et al.	
	US-8,082,096-B2	12-20-2011	Dupray	

Examiner:

Date Considered:

EXAMINER: Initial if reference considered, whether or not citation is in conformance with MPEP 609; Draw line through citation if not in conformance and not considered. Include copy of this form with next communication to applicant.

Substitute for form 1449/PTO  <b>INFORMATION DISCLOSURE STATEMENT BY APPLICANT</b>	<b>Complete if Known</b>
	Application Number    --Unknown--
	Filing Date            --Submitted herewith--
	First Named Inventor    Reed
	Examiner Name         -- Unknown --
	Art Unit                -- Unknown --
	Attorney Docket No.    TX1000-C7

Examiner Initials	Document Number	Publication Date MM-DD-YYYY	Name of Patentee or Applicant of Cited Document	Pages, Columns, Lines, Where Relevant Passages or Relevant Figures Appear
	US-20030146871-A1	08-07-2003	Karr, et al.	
	US-9,134,398-B2	09-15-2015	Dupray, et al.	
	US-7,274,332-B1	09-25-2007	Dupray	
	US-6,466,565-B1	10-15-2002	Wax, et al.	
	US-6,111,538	08-29-2000	Schuchman, et al.	
	US-8,994,591-B2	03-31-2015	Dupray, et al.	
	US-6,204,813-B1	03-20-2001	Wadell, et al.	
	US-6,064,339	05-16-2000	Wax, et al.	
	US-7,020,475-B2	03-28-2006	Bahl, et al.	
	US-6,799,047-B1	09-28-2004	Bahl, et al.	
	US-6,026,304	02-15-2000	Hilsenrath, et al.	
	US-6,393,294-B1	05-21-2002	Perez-Breva, et al.	
	US-6,269,246-B1	07-31-2001	Rao, et al.	
	US-7,164,883-B2	01-16-2007	Rappaport, et al.	
	US-7,664,492-B1	02-16-2010	Lee, et al.	
	US-7,043,254-B2	05-09-2006	Chawla, et al.	
	US6,973,622-B1	12-06-2005	Rappaport, et al.	
	US-6,631,267-B1	10-07-2003	Clarkson, et al.	
	US-6,842,431-B2	01-11-2005	Clarkson, et al.	
	US-7,120,431-B1	10-10-2006	Huo, et al.	
	US-20030054811-A1	03-20-2003	Han, et al.	
	US-7,319,847-B2	01-15-2008	Xanthos, et al.	
	US-6,587,690-B1	07-01-2003	Di Huo, et al.	
	US-7,096,160-B2	08-22-2006	Skidmore, et al.	
	US-20020155816-A1	10-24-2002	Fodor, et al.	
	US-5,920,607	07-06-1999	Berg	
	US-9,528,843-B2	12-27-2016	Pu, et al.	

Examiner: \_\_\_\_\_

Date Considered: \_\_\_\_\_

EXAMINER: Initial if reference considered, whether or not citation is in conformance with MPEP 609; Draw line through citation if not in conformance and not considered. Include copy of this form with next communication to applicant.

Substitute for form 1449/PTO  <b>INFORMATION DISCLOSURE STATEMENT BY APPLICANT</b>	<b>Complete if Known</b>
	Application Number    --Unknown--
	Filing Date            --Submitted herewith--
	First Named Inventor    Reed
	Examiner Name         -- Unknown --
	Art Unit                -- Unknown --
	Attorney Docket No.    TX1000-C7

Examiner Initials	Document Number	Publication Date MM-DD-YYYY	Name of Patentee or Applicant of Cited Document	Pages, Columns, Lines, Where Relevant Passages or Relevant Figures Appear
	US-7,003,264-B2	02-21-2006	Fodor, et al.	
	US-5,799,154	08-25-1998	Kuriyan	
	US-20020152303-A1	10-17-2002	Dispensa	
	US-6,088,588	07-11-2000	Osborne	
	US-6,745,011-B1	06-01-2004	Hendrickson, et al.	
	US-6,751,443-B2	06-15-2004	Haymes, et al.	
	US-6,650,896-B1	11-18-2003	Haymes, et al.	
	US-7,079,945-B1	07-18-2006	Kaplan	
	US-6,374,177-B1	04-16-2002	Lee, et al.	
	US-20020164998-A1	11-07-2002	Younis	
	US-20030065442-A1	04-03-2003	Touney	
	US-6,405,123-B1	06-11-2002	Rennard, et al.	
	US-6,615,131-B1	09-02-2003	Rennard, et al.	
	US-20020115453-A1	08-22-2002	Poulin, et al.	
	US-6,725,156-B2	04-20-2004	Kaplan	
	US-6,947,837-B2	09-20-2005	Fukushima, et al.	
	US-7,149,625-B2	12-12-2006	Mathews, et al.	
	US-20020194498-A1	12-19-2002	Blight, et al.	
	US-6,609,005-B1	08-19-2003	Chern	

FOREIGN PATENT DOCUMENTS				
Examiner Initial	Foreign Patent Document	Publication Date MM-DD-YYYY	Name of Patentee or Applicant of Cited Document	Pages, Columns, Lines, Where Relevant Passages or Relevant Figures Appear
	EP-1,374,481-B1	11-23-2005	Xanthos, et al.	

Examiner: \_\_\_\_\_ Date Considered: \_\_\_\_\_

EXAMINER: Initial if reference considered, whether or not citation is in conformance with MPEP 609; Draw line through citation if not in conformance and not considered. Include copy of this form with next communication to applicant.

Substitute for form 1449/PTO  <b>INFORMATION DISCLOSURE                  STATEMENT BY APPLICANT</b>	<b>Complete if Known</b>
	Application Number    --Unknown--
	Filing Date            --Submitted herewith--
	First Named Inventor    Reed
	Examiner Name        -- Unknown --
	Art Unit                -- Unknown --
	Attorney Docket No.    TX1000-C7

NON PATENT LITERATURE	
Examiner Initial	Include name of author (in CAPITAL LETTERS), title of the article (when appropriate), title of the item (book, magazine, journal, serial, symposium, catalog, etc.), date, page(s), volume-issue number(s), publisher, city and/or country where published.
	Office Action in 15/297,222 mailed on 12/14/2016, 23 pages (pp. 1-23 in pdf).
	Notice of Allowance in 15/297,222 mailed on 01/12/2017, 6 pages (pp. 1-6 in pdf).
	Office Action in 15/099,960 mailed on 06/28/2016, 15 pages (pp. 1-15 in pdf).
	Notice of Allowance in 15/099,960 mailed on 11/29/2016, 38 pages (pp. 1-38 in pdf).
	Office Action in 14/642,408 mailed on 08/10/2016, 21 pages (pp. 1-21 in pdf).
	Notice of Allowance in 14/642,408 mailed on 09/28/2016, 6 pages (pp. 1-6 in pdf).
	Office Action in 11/505,578 mailed on 07/07/2009, 7 pages (pp. 1-7 in pdf).
	Office Action in 11/505,578 mailed on 05/12/2010, 4 pages (pp. 1-4 in pdf).
	Final Office Action in 11/505,578 mailed on 11/09/2010, 6 pages (pp. 1-6 in pdf).
	Office Action in 11/505,578 mailed on 08/18/2011, 7 pages (pp. 1-7 in pdf).
	Office Action in 11/505,578 mailed on 03/28/2012, 7 pages (pp. 1-7 in pdf).
	Final Office Action in 11/505,578 mailed on 12/12/2012, 8 pages (pp. 1-8 in pdf).
	Notice of Allowance in 11/505,578 mailed on 05/06/2014, 13 pages (pp. 1-13 in pdf).
	Office Action in 10/255,552, mailed on 08/10/05, 12 pages (pp. 1-12 in pdf).
	Final Office Action 10/255,552, mailed on 03/07/06, 19 pages (pp. 1-19 in pdf).
	LUI, et al., "Location Updates and Probabilistic Tracking Algorithms for Mobile Cellular Networks", Fourth International Symposium on Parallel Architectures, Algorithms, and Networks, June 1999, 6 pages (pp. 1-6 in pdf), US.
	KRISHNA, "Performance Issues in Mobile Wireless Networks", Office of Graduate Studies of Texas A&M University, August 1996, 204 pages (pp.1-204 in pdf), US.
	ANONYMOUS, "LADOT'S ADAPTIVE TRAFFIC CONTROL SYSTEM (ATCS)", Presentation at the TRB Workshop on Adaptive Traffic Signal Control Systems, 9 January 2000

Examiner:

Date Considered:

EXAMINER: Initial if reference considered, whether or not citation is in conformance with MPEP 609; Draw line through citation if not in conformance and not considered. Include copy of this form with next communication to applicant.