

[54] **INTERACTIVE, COMPUTERISED GAMING SYSTEM WITH REMOTE TERMINALS**

[76] Inventor: **Julian Menashe**, 54 Copley Park,
 London SW16 3DB, United Kingdom

[21] Appl. No.: **252,538**

[22] Filed: **May 19, 1994**

[30] **Foreign Application Priority Data**

- May 19, 1993 [ZA] South Africa 93/3483
- [51] **Int. Cl.⁶** **A63F 9/22**
- [52] **U.S. Cl.** **463/41; 463/29; 463/16**
- [58] **Field of Search** **273/138 A, 439, 273/269; 463/16, 29, 41**

[56] **References Cited**

U.S. PATENT DOCUMENTS

- 4,494,197 1/1985 Troy et al. .
- 4,856,787 8/1989 Itkis 273/269
- 4,948,138 8/1990 Pease et al. 273/138 A
- 5,324,035 6/1994 Morris et al. 273/138 A
- 5,326,104 7/1994 Pease et al. 273/138 A
- 5,351,970 10/1994 Fioretti 273/439

FOREIGN PATENT DOCUMENTS

- 0542664 5/1993 European Pat. Off. .
- 2147773 5/1985 United Kingdom .

2151054 7/1985 United Kingdom .

Primary Examiner—Angela D. Sykes
Assistant Examiner—Eric F. Winakur
Attorney, Agent, or Firm—Young & Thompson

[57] **ABSTRACT**

The gaming system includes a host computer, a plurality of general purpose terminal computers forming player stations remote from the host, means for providing communication between each of the terminals and the host. Each terminal has a program for generating screen graphics and sound locally in response to control data packets generated by and received from the host. The host generates random numbers for a game being played on a connected terminal within preset criteria for that game in response to data packets received from the terminal. The data packets are of variable length between 1 and 80 bytes. The host sequentially stores the minimum significant information for replaying a game, auditing and security, such as accounting data of each player at the start of each game, random numbers generated by the host, responses received from a player, and whether a game was completed. Play is substantially real-time, because only minimal data is transmitted with functions requiring large amounts of data, such as screen graphics being generated locally. The statuses of host and terminal are restored automatically on re-establishing communication following an interruption to ensure fairness to players and prevent them defeating the outcome of a game.

17 Claims, 1 Drawing Sheet

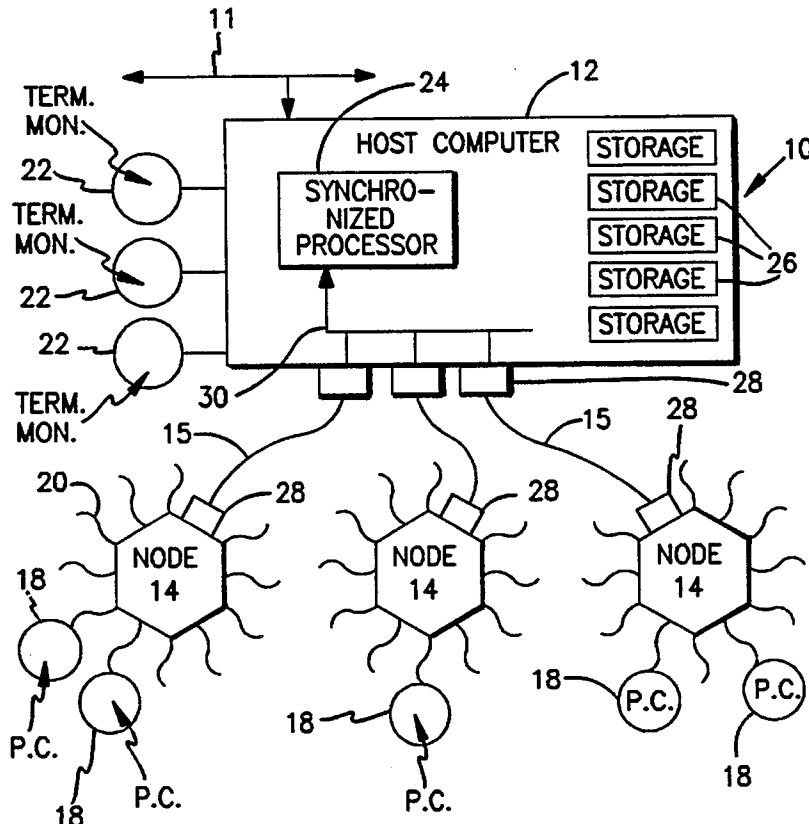

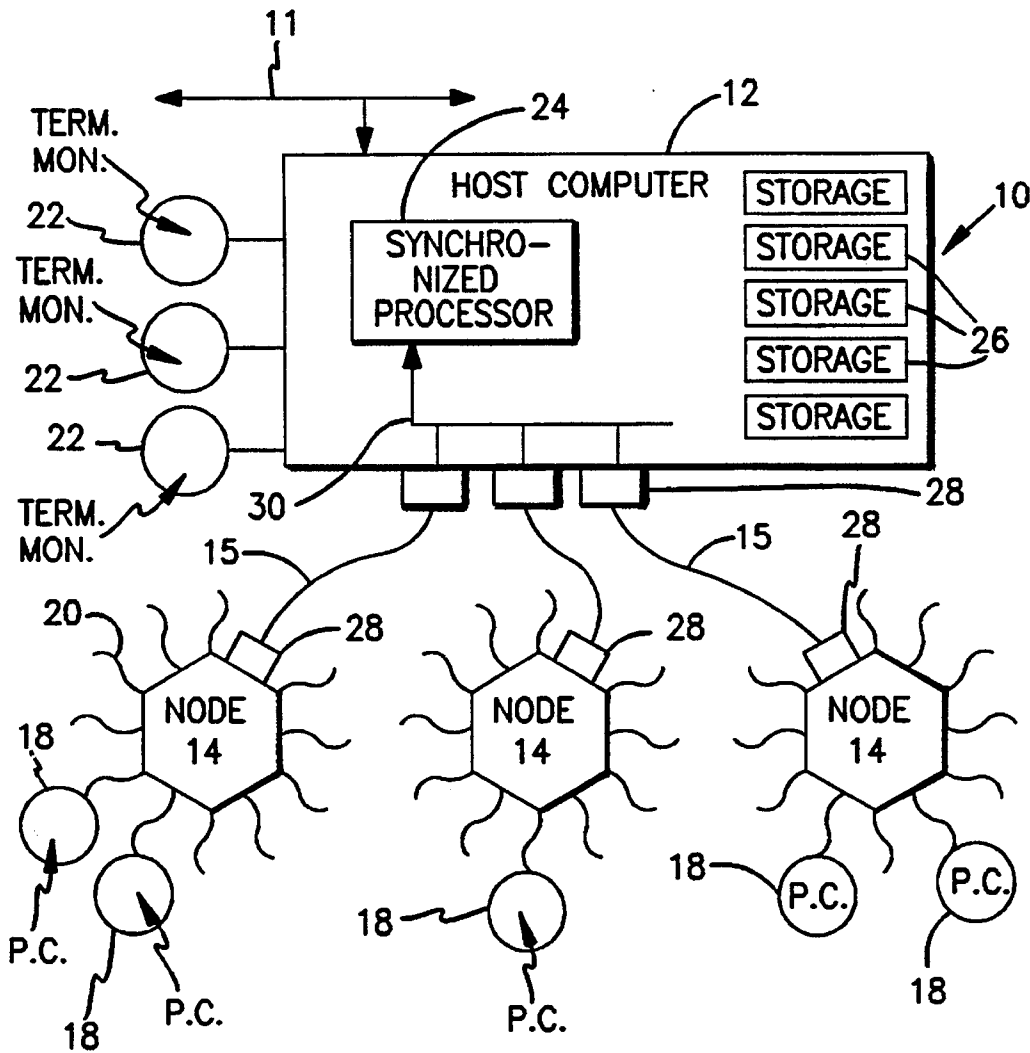

FIG. 1

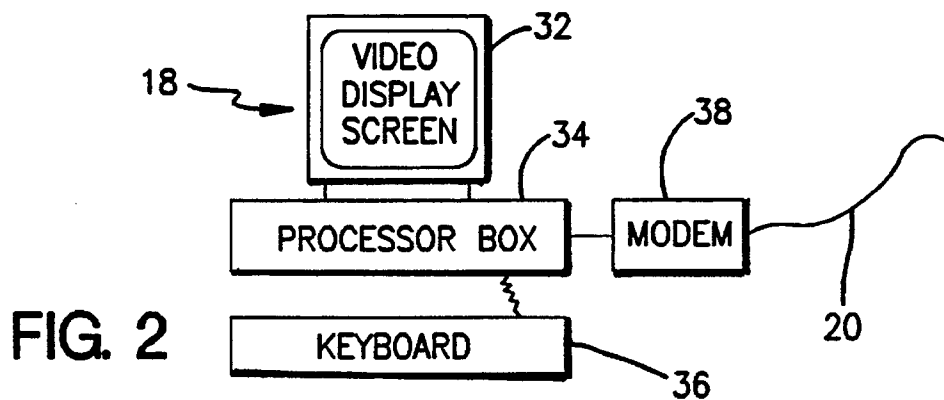

FIG. 2

INTERACTIVE, COMPUTERISED GAMING SYSTEM WITH REMOTE TERMINALS

FIELD OF THE INVENTION

This invention relates to an interactive, real time, realistic "home" computer gaming system using general purpose computers. The system comprises a central or host computer, a plurality of terminal computers forming player stations remote from the host, communicating means for connecting each of the terminals to the host, and program means for operating the computers and the communication between the terminals and host. Aspects of the invention concern auditing and security to ensure fairness for players and prevent players defeating the outcome of a game; fast, efficient communication to enable reliable, low cost, real time, realistic operation; accounting; and enabling players to play a variety of games.

BACKGROUND OF THE INVENTION

Many computerised gaming systems have been proposed having a host and terminals, which may be remote or local, with different operating systems depending largely on the game being played. The broad general groupings are discussed below as a survey of the art.

One group is centred on horse betting using home or agency terminals. Home terminal systems usually use a teletext or teletext type interface to display betting and account data on the terminal and to input bets to the host often coupled with a control for television viewing. Data may also be transmitted through a telephone system. Betting inputs are simple, such a horse or horse couple number. Patents disclosing typical systems are JP 1-269157 to JP 1-269164. Agency terminals are broadly similar, but have betting slip reading and/or printing facilities. Patents disclosing typical systems are FR 2,368,092, GB 2,269,926, 2,262,635, 2,075,369, 2,028,558, 1,491,780. Such systems are not interactive; are not real time because of the delays in transmitting large volumes of data; have limited auditing and/or playback capabilities because of the large amount of data that has to be stored; and are not realistic in that limited information only is displayed on the terminal screens. Auditing and data storage is problematical and generally, if there is a fault, then a bet is voided. Such systems are restricted to one form of gaming only and use dedicated or special equipment; as such are unsuitable for general gaming purposes.

A second group, typified by U.S. Pat. No. 4,922,522 and PCT applications WO 92/10806 and WO 89/05490, are computer based lottery ticket distributing systems. Apart from providing systems for the practical demands of participants, such as selection verification, ticket reading, etc., these systems are primarily concerned with data security and storage. They are not interactive, real time, adaptable to other games, and of necessity use dedicated equipment.

A third group, eg. U.S. Pat. Nos. 3,909,002, 4,339,798 and 4,467,424 concern computerised gaming systems that enable players to participate in casino games, like craps, roulette and keno, at terminals rather than at the tables. With these systems a game actually being played in a casino is displayed to a remote player via a television or dedicated display panel. Players place their bets via panels on the terminals. The outcome of the game and account balances for each player are stored in a central computer and displayed on each player's panel. The system and games being played are not interactive and a croupier enters game details

as it is being played. These systems mimic actual games, are not interactive, require dedicated terminals, need large volumes of data to be stored and transmitted and, because of data transmission problems, are limited to local area use. Such systems are suitable for use in, and are believed to have been used in, hotel casinos.

A fourth group, eg. U.S. Pat. No. 4,760,527 and 4,926,367, provide computerised interactive wagering, specifically playing poker, among a plurality of players. The system uses a central computer and dedicated terminals. Large volumes of data are transmitted between machines to display games and outcomes, so that the terminals are confined to a local area. The games are interactive as among players, but not as between each player and the central computer. The central computer does not simulate a game.

Finally there are so called "television (or video) game" systems which attempt to provide real time, interactive gaming. JP 2-295,338 discloses one such system having a host or central computer transmit screen display data to dedicated terminals via a telephone line. Telephone dial buttons allow a player to input responses. While the game is interactive, real time play is not achieved because of the time required to transmit the volume of data required to generate the screen images. U.S. Pat. No. 4,652,998 discloses a video amusement gaming system using a host and local dedicated machines for playing games, with a prize award pool being provided and awarded depending on allocation of prizes and outcomes of games. Fixed length data packets are transmitted between host and terminals which is inefficient and limit the width of the area of operation and recording of results is limited. With both these systems record storing is minimal and they are not appropriate for wagering.

Generally, while most of such systems as mentioned above concerned with wagering have accounting and auditing/security facilities, these are limited in nature largely because of the volume of data to be stored, the fact that data has to be stored continuously and the problem of errors. For example, to replay an event immediately prior to a fault, one has to store the position of the program being executed, which screens were showing, the state of the memory of the each of the host and each active terminal, and events or inputs leading up to that time of the fault. This is a monumental task, because one can never be sure when a fault is about to occur, and slows operation of each of the computers.

Most known systems thus default to voiding a game in the event of a fault, which is unfair if the fault is beyond the control of the player. On the other hand some system is required to prevent a player from deliberately defeating the outcome of a game.

This invention seeks to provide a casino gaming system capable of interactive, real time, realistic gaming at genuinely remote locations which is economical, secure and reliable. Aspects of the invention seek to minimise telephone line usage and cost and terminal costs; to enable a variety of casino games to be played in such a manner that a player experiences the same "feel", security, etc. as if he were at a casino; and to ensure that faults, deliberate or accidental, in communication and at terminals do not lead to abuse by players or the entity operating the host computer.

Fast, multitasking processing can be achieved by a single, large computer, such as so called "main frame" or "mini" machines. With known technology it is now also possible to achieve the same or even better performance using a local or wide area network of fast, relatively smaller computers each running a multitasking operating system. Technology in this

field is increasing exponentially and it is not unrealistic to expect that within a short while a single "personal" computer or so called "application server" could perform substantially the same function as a current main frame. Thus, the terms "host computer" or "host" used herein are to be interpreted broadly to cover machines ranging from a single computer to a plurality of networked computers capable of performing the tasks of playing games; attending to record keeping, accounting, security and communication functions; and servicing a number of players simultaneously.

The term "simulations" as used herein means computer screen graphics, sound or screen graphics and sound that provide visual and optionally audible messages and representations to a player, such as instructions and game simulations.

SUMMARY OF THE INVENTION

The invention provides a gaming system including a host computer, a plurality of terminal computers forming player stations remote from the host, communicating means for connecting each of the terminals to the host, and program means for operating the computers, wherein: each terminal is a general purpose computer having terminal program means for generating simulations for establishing a secure communication with the host, generating simulations to reproduce at least one game and a current player status in response to host control data packets received from the host, generating terminal control data packets, each representative of a valid response at the terminal, and sending such packets to the host; the host has host program means for generating random numbers for a game being played on a connected terminal within preset criteria for that game in response to a data packet received from the terminal, generating host control data packets for controlling the simulations to be reproduced by the connected terminal; and the data packets are of variable length, each of which is dependent on the minimum relevant information required to be transmitted for playing a game.

Preferably, the terminal program includes game data for generating simulations for a plurality of games.

For auditing and security the host preferably has means for sequentially storing accounting data of each player, the random numbers generated by the host, responses received from each player connected to the host, and whether each game has been completed. The stored information is a record of games played and partially played by a player may be used for automatically restoring the statuses of the host and terminal following an interruption in communication between them and/or for replaying on demand at least a portion of at least one game. This ensures fairness for players in the event of a fault, while protecting the operator of the host against players deliberately defeating the outcome of a game, such as by switching off their computers or breaking communication with the host. Minimal storage capacity is required at the host as the stored information corresponds to a sequence of valid player keystroke responses and random numbers generated by the host.

The communicating means preferably comprises modem means on each computer and a telecommunication link. This is general purpose, relatively inexpensive equipment with low operating costs, so that together with the use of general purpose computers players can participate at home or other remote location at little cost. Operating costs for players may be further minimised by using at least one node device connectable, in use, to each of a plurality of terminal computers located within a desired low charge zone and being constructed to route communication between each active terminal and the host. Players thus pay local-call

charges only or nothing if they communicate with the host via a toll-free number to the node. The host operator bears minimal costs per player of a high quality link from each node to the host for example, because the costs of the link are amortised over a large number of players. This is important for long distance communication, eg. between cities and/or countries.

The use of small, variable length data packets enables fast and reliable communication between the computers, as the volume of transmitted data is minimised for rapid message transmission. Verification, acknowledgement and re-transmission of data, if needed, will also be extremely quick. A typical response time of under half a second may be expected at the terminal from the time a keystroke is made by a player to the time the terminal screen has been fully updated ready to accept the next player keystroke.

Processing is distributed in what is known in the art as a "client/server" system or application; only essential or relevant data is transmitted between the host and terminals, while each computer processes only those portions of the program means needed to produce a required output, such as a result and account data at the host and simulations at the terminals, and data storage and access is done at a defined location. From this flows the advantage for gaming that processing and transmission are both fast, thereby providing substantial real time operation.

Benefits of using general purpose computers as terminals are low cost for the operator and player; ability to modify, improve or add to the system at little expense using readily available equipment and programs supplied by the host operator; low maintenance and operating costs; and giving each player the freedom to choose the speed and quality of performance he or she desires. Fast processing for the host is easily attainable at relatively low cost, as it has relatively little processing to do for each player since processing of simulations is done at the terminals.

The data packets may be suitably encrypted. Passwords may be used for establishing communication between the host and a terminal and for each player, who may play at any terminal by using his password. Technology for this is well known in the art and any suitable techniques may be used.

A feature of the invention is that the games are interactive, ie. each player selects which game he wishes to play, such as blackjack, video poker, slots, etc., and the host simulates outcomes for that game individually for that player depending on the player's choices during the game. Additionally, program options may be provided for several players to play one game simultaneously against "the house" or one another as desired, such as poker, blackjack, and punto banco, according to casino conventions. Thus, a real life simulation of playing in a casino can be offered to players at home or remote terminals. Additionally non- and partially-interactive games, such as lotteries, bingo, roulette, etc. may also be played with little modification.

Further features, variants, and/or advantages, of the invention will become apparent from the following non-limiting description made with reference to the accompanying schematic drawings of a presently preferred embodiment of the invention.

BRIEF DESCRIPTION OF THE DRAWINGS

FIG. 1 shows a schematic of a gaming system for playing casino games at terminals located remotely from the casino; and

FIG. 2 shows a schematic front view of a player terminal.

DESCRIPTION OF PREFERRED EMBODIMENTS

In the drawings the same or similar parts are indicated by the same reference numbers.

The drawings show a computerised gaming system **10** for playing casino games comprising a central or host computer **12** at a casino, telecommunication exchanges or nodes **14** connected by lines or paths **16** to the host, and general purpose computers or PC's **18** serving as player terminals connected by telecommunication lines or paths **20** to the nodes **14**. Further computer terminal monitors **22** as are located at the host.

The host **12** is a fast, powerful, reliable computer, such as a main frame, mini or application server having one or more synchronised processors **24** and fast, reliable, large capacity data storage devices **26** such as that known in the art as a "RAID disk array". The processor/s run several programs simultaneously to determine outcomes of games of chance according to accepted gaming principles and rules under the control of a master program or operating system. The data storage devices **26** store data bases of player, game and accounting information as well as programs for the host and for downloading to the terminals when required. The host has a number of communication devices or cards **28** connected via a bus **30** to the processor/s and each connected to a line **16**. Each device **28** operates bi-directionally to separate and decompress data received in one stream along line **16** into individual streams for each player and compress and compact data into one stream sent out along line **16** to the node **14**.

Each PC **18** has a video display screen **32**, a box **34** with processor, data disk devices, function cards such as sound cards, etc. as known in the art and not separately illustrated, a keyboard **36**, and a modem **38** connected to a line **20**. The PC may also have a mouse, not shown.

Each node **14** is a computerised, electronic, switching exchange for selectively connecting each active PC **18** to the line **16** to transmit data between the host and PC. The node is constructed and operated in a known manner to monitor the flow of data between host and PC's to maximise the total information transfer rate and serve each PC as quickly as possible. Thus each node has a communication device **18** functioning as described above to communicate with the host via line **16** and a plurality of modems for communicating with the PC's **18**.

Each line **16** is a high quality, dedicated link, such as a high speed line, a fibre optic line or a satellite link, adapted to provide continuous, reliable, high-speed data communication between the host and each node. The lines **20** are public communication links or telephone lines which are energised or established when needed to provide communication between each terminal and the host. The lines **16** provide relatively low cost long distance communication for each terminal because of amortisation of their costs over the large number of terminals they serve. The nodes are located such that the terminals connected to each is within a low cost communication charge zone.

Each PC **18**, when used as a terminal for gaming runs a program capable, amongst other things, of generating suitable simulations for a casino game on the display. The same program or several separate program modules may be used for playing a variety of games. The PC does not determine the outcome of any game of chance and thus cannot be considered itself to be a gaming device in the normal sense of the term.

In practice, the system is used as follows.

A person wishing to play a game of chance from a remote PC established an account with a casino or host operator, deposits a opening balance, is allocated a personal password, and is given a gaming software including programs and data for generating screens appropriate to casino games. The gaming program or modifications to it may be downloaded directly from the host via a communications link if required. When the player wishes to play he activates his PC, loads the gaming program, communicates with the casino via the modem and node and "logs in" by supplying his password, which is verified by the host. The host supplies an encryption key code, which is unique for the player and may be unique for the particular communication; the key code is used to code and decipher encrypted data communicated between the PC and host by providing a one-to-one correlation between a set of transmitted characters and a set of program interpretable characters. Communication is now established.

The host then generates and sends a data packet to the PC that is decoded and processed to cause the PC's gaming program to display a game choice screen and the player's account balance. The data packet comprises a start byte, a length byte to indicate the number of sub-packets in this packet, a variable number of sub-packets followed by CRC bytes, i.e. two bytes if CRC **16** is used and four if CRC **32** is used, etc. The sub-packets behave like subroutine arguments to the terminal program. The first 2 bytes define the graphic and sound subroutine to be used and the next 12 bytes the compressed arguments. These bytes can represent 12 ASCII characters or six 2-byte integers or three 4-byte real numbers or a combination of all three for modifying the screen to display the account balance and other information. Multiple sub-packets can be sent in a single packet and multiple packets can be sent until the program running on the host requires input from the player. The last sub-packet is tagged by setting high one of the bits in the 2 bytes defining the subroutine to be called to indicate an end of transmission. The player's terminal acknowledges receipt of each packet by sending an acknowledge byte if the data is good or a negative acknowledge byte if the data is bad and re-transmission is required. The player selects a game to be played using his keyboard or mouse or other input device. A single key is pressed or graphic icon selected and converted to the equivalent keystroke and a data packet of 3 bytes is generated and transmitted. The 3 byte data packet consists of a start byte, a data byte and the one's complement of the data as a check byte. The host acknowledges receipt of the packet if it is received correctly or sends a negative acknowledge requesting re-transmission.

Assuming a card game, such as blackjack, is selected, the host activates: a suitable program module for generating random numbers for blackjack, say 1 to 52 each representing a unique card in a deck of cards; a data base module for evaluating outcomes; and a program module for generating appropriate data packets. The host then generates and transmits a data packet for the PC to reproduce a blackjack simulations on the video display including a request for the player to "place" his bet and a selection of valid keys that correspond to predefined bet values and an audio communication if the PC is capable producing suitable audio effects, such as a voice request to place his bet. The player presses an appropriate key to place his bet and "deal" his cards; this cause the PC's program to generates and transmit a 3 byte data packet to the host. In response, the host, using suitable random number and data base modules and an algorithm to draw unique cards from a deck of cards, "deals" cards for the house and player according to the rules of the

Explore Litigation Insights

Docket Alarm provides insights to develop a more informed litigation strategy and the peace of mind of knowing you're on top of things.

Real-Time Litigation Alerts



Keep your litigation team up-to-date with **real-time alerts** and advanced team management tools built for the enterprise, all while greatly reducing PACER spend.

Our comprehensive service means we can handle Federal, State, and Administrative courts across the country.

Advanced Docket Research



With over 230 million records, Docket Alarm's cloud-native docket research platform finds what other services can't. Coverage includes Federal, State, plus PTAB, TTAB, ITC and NLRB decisions, all in one place.

Identify arguments that have been successful in the past with full text, pinpoint searching. Link to case law cited within any court document via Fastcase.

Analytics At Your Fingertips



Learn what happened the last time a particular judge, opposing counsel or company faced cases similar to yours.

Advanced out-of-the-box PTAB and TTAB analytics are always at your fingertips.

API

Docket Alarm offers a powerful API (application programming interface) to developers that want to integrate case filings into their apps.

LAW FIRMS

Build custom dashboards for your attorneys and clients with live data direct from the court.

Automate many repetitive legal tasks like conflict checks, document management, and marketing.

FINANCIAL INSTITUTIONS

Litigation and bankruptcy checks for companies and debtors.

E-DISCOVERY AND LEGAL VENDORS

Sync your system to PACER to automate legal marketing.