



In the event that a petition to extend time under 37 CFR 1.136 is necessary in the parent application to maintain copendency for this application, a petition for an extension of the necessary time to maintain copendency is hereby requested for the parent application and the Commissioner is hereby authorized to debit our Account Number 10-0447 for the necessary fees.

The filing fee has been calculated as shown below:

	<u>NO. FILED</u>	<u>NO. EXTRA</u>	<u>RATE</u>	<u>FEE</u>
<b><u>BASIC FEE</u></b>				<b><u>\$710</u></b>
<b><u>TOTAL CLAIMS</u></b>	<b><u>36-20</u></b>	<b><u>16</u></b>	<b><u>\$18</u></b>	<b><u>288</u></b>
<b><u>INDEPENDENT CLAIMS</u></b>	<b><u>7-3</u></b>	<b><u>4</u></b>	<b><u>\$80</u></b>	<b><u>320</u></b>
<b><u>MULTIPLE DEPENDENT CLAIM(S) PRESENTED</u></b>			<b><u>\$260</u></b>	
<b><u>TOTAL FEES: ___</u></b>				<b><u>\$1,318</u></b>
<b><u>Deduct one-half of fee for Small Entity</u></b>				<b><u>-</u></b>
<b><u>ASSIGNMENT RECORDAL FEE</u></b>			<b><u>\$40</u></b>	<b><u>40</u></b>
<b><u>TOTAL AMOUNT DUE:</u></b>				<b><u>\$1,358</u></b>

- Please charge my Deposit Account No. 10-0447 in the amount of \$
- Check in the amount of \$1,358.00 is attached. Please charge any deficiency or credit any overpayment to Deposit Account No. 10-0447.
- The Commissioner is hereby authorized to charge payment of the following fees during the pendency of this application or credit any overpayment to Deposit Account No. 10-0447.
  - Any patent application processing fees under 37 CFR 1.17 and under 37 CFR 1.20(d).
  - The issue fee set in 37 CFR 1.18 at or before mailing of the Notice of Allowance, pursuant to 37 CFR 1.311(b).
  - Any filing fees under 37 CFR 1.16 including fees for presentation of extra claims.

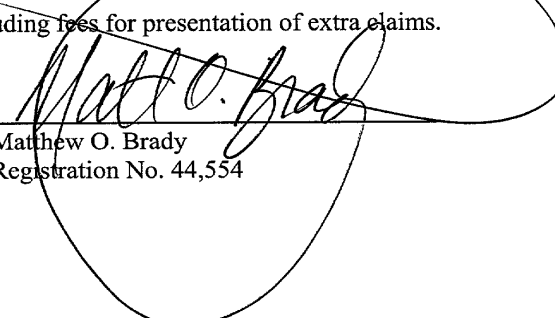
  
 Matthew O. Brady  
 Registration No. 44,554

JENKENS & GILCHRIST  
 3200 Fountain Place  
 1445 Ross Avenue  
 Dallas, Texas 75202-2799  
 312/425-8512 (Direct)  
 312/425-3909 (Fax)



**METHOD OF TRANSFERRING GAMING DATA ON A  
GLOBAL COMPUTER NETWORK**

**FIELD OF THE INVENTION**

5 The present invention relates generally to gaming machines and, more particularly, to a method of transferring data from a gaming establishment to a player at a remote site via a global computer network.

**BACKGROUND OF THE INVENTION**

10 Gaming machines, such as slot machines, video poker machines and the like, have been a cornerstone of the gaming industry for several years. Generally, the popularity of such machines with players is dependent on the likelihood (or perceived likelihood) of winning money and the intrinsic entertainment value of the machine relative to other available gaming options. Shrewd operators consequently strive to employ the most entertaining and exciting machines available because such machines attract frequent play and hence increase profitability to the operator. Accordingly, in  
15 the competitive gaming machine industry, there is a continuing need for gaming machine manufacturers to produce different methods to attract frequent play by enhancing the entertainment value and excitement associated with the game.

20 Many game players want to be able to play gaming machines much more frequently than they are currently able to do. Such players are often limited because of the requisite travel required to attend casinos or other legal gaming establishments located in select portions of the United States. The involvedness, cost and inconvenience of a player being forced to travel to a gaming establishment severely limits the amount of gambling excursions that a player can assume. Furthermore, since these excursions are infrequent, a gaming player is often forced to spend as  
25 much time gambling as possible during the excursion because such a player may not have the means to return to the gaming establishment for several months or years. There is continuing need for a gaming player to be able to gamble more frequently or for a shorter period time than is currently available and to be able to do so from a location remote to the gaming establishment.



The present invention is directed to satisfying these needs. The foregoing and other advantages of the invention will become apparent upon reading the following detailed description.

### SUMMARY OF THE INVENTION

5 A remote gaming method comprising a player accessing, via a remote terminal, a gaming site on a global computer network connected to the remote terminal. The player is able to provide via the remote terminal, personal identification information to the gaming site and select, via the remote terminal, a game of chance located at a gaming establishment for remote play. The remote terminal is located  
10 outside the gaming establishment. The player places, via the remote terminal, a wager for playing the selected game and receives randomly generated text or graphical outcome data at the remote terminal for the selected game. The outcome data being generated by either a gaming server or a gaming machine at the gaming establishment and is subsequently relayed to the gaming site.

### DESCRIPTION OF SPECIFIC EMBODIMENTS

15 While the invention is susceptible to various modifications and alternative forms, specific embodiments have been shown by way of example and will be described in detail herein. However, it should be understood that the invention is not intended to be limited to the particular forms disclosed. Rather, the invention is to  
20 cover all modifications, equivalents, and alternatives falling within the spirit and scope of the invention as defined by the appended claims.

The present invention comprises a method by which data can be transferred from a gaming establishment to a gaming player disposed in a remote location from the gaming establishment. Generally, a player accesses the host gaming  
25 establishment by use of a global computer network. The host gaming establishment engages in gambling-type activities (*e.g.*, a slot machine play) and reports the outcomes to the remote player.

During the 1990's, global computer networks, such as the World Wide Web accessed through the Internet, became increasingly popular outlets. It is contemplated  
30 in accordance with the present invention that other types of global computer networks are available. The Internet is a global communications network built on worldwide

data and telephone networks. Computers connected to the Internet can exchange information with any other connected computer. The backbone of the Internet is founded on various sets of major telephone conduits and switches that exist across the world. These communications conduits are designed to move large volumes of data

5 traffic at extremely high rates of speed.

Each of the major conduits referred to above terminates at a router, which is a large, fast switch that sorts the large volumes of data. Each router is connected to additional, local routing devices. Local routing devices, called "points of presence" provide local Internet access. For example, an Internet termination router located in

10 Chicago may have point of presence routers connected in, for example, Milwaukee and Indianapolis. A router is able to connect as many point of presence routers as the capacity of the switching systems and the Internet will permit.

In addition to point of presence routers, commercial Internet exchanges and global Internet exchanges also connect to the routers. These exchanges transfer data

15 between Internet service providers, both nationally and internationally. When data originates on one U.S. Internet service provider with a destination on another U.S. long distance provider, the data is first routed to the commercial Internet exchange where it makes the transfer between providers.

Personal computers typically connect to a local point of presence router through a local Internet carrier. A local Internet carrier obtains a direct line to the point of presence router and provides a modem or other connection by which a personal computer user achieves Internet access. When the personal computer connects to the modem of the local Internet carrier, the local Internet carrier switches the home computer to the point of presence router, which in turn connects the

25 personal computer to the Internet.

Another method of connecting computers to the Internet is by direct connection through a local area network (LAN) to the point of presence. Multiple personal computers can be connected to a single LAN, which connects to the point of presence through a leased data line. The computers connected to the LAN receive

30 and transmit data to the point of the presence through the LAN.

Attached to most LANs are a variety of different servers including the File Server and the Hypertext Transport Protocol ("HTTP") server. The File Server

EXHIBIT 105066

connects to the LAN and contains the common data files used by the personal computers, the LAN and other servers. An HTTP server is a particular type of server that processes incoming and outgoing data written according to a certain Internet communication protocol, called hypertext transport protocol.

5 As described above, the Internet is able to interconnect every computer on the Internet with every other computer on the Internet. An Internet site typically includes certain data files (called "web pages" that are a part of the World Wide Web) in its File Server. The Internet site HTTP server makes those pages available to other computers on the Internet. An HTTP Server that makes World Wide Web pages  
10 available on the Internet usually includes a so-called "home page," the starting point for outside users to navigate through the underlying World Wide Web pages serviced by the HTTP Server. These World Wide Web pages are written in a special World Wide Web language called Hypertext Markup Language ("HTML"). When a personal computer user wants to view a home page, it can do so by requesting that  
15 data over the Internet. In response, the requisite LAN retrieves the web page data from its File Server and instructs its HTTP Server to transmit the data, addressed via the Internet, to the personal computer that requested the information. The data generally travels from the local leased link to the point of presence router near the location of the LAN, through the Internet, through the point of presence router near  
20 the requesting personal computer, through the local Internet carrier, and into the modem of the requesting personal computer.

Transmission Control Protocol/Internet Protocol ("TCP/IP") controls transmission of data on the Internet to provide World Wide Web communication to users. To insure that data is sent to and received by the appropriate receiver on the  
25 Internet, every device communicating on the Internet is assigned a unique address called an Internet Protocol ("IP") address. Elements of the IP address identify the location in the network that a device is connected. Other parts of the IP address identify the specific device. The IP address number has a three-digit element that identifies the state of the resident and an additional seven digits, three of which  
30 identify the local exchange of the resident and four digits that specifically identify the home of the resident. The IP address is presently a thirty-two bit binary address, readily processed by computers, but cumbersome for use by human users.



server storing the particular home page. When the hypertext is selected, the browser requests a connection to the HTTP server hosting the file and it also requests from the HTTP server the file identified by the URL address. If the HTTP server accepts the connection requested by the browser, the HTTP server proceeds to transmit the requested file back to the browser. Once the browser receives the requested file, it delivers or presents the content of the file to the requesting user.

One of the most popular mediums for browsing the Internet is the World Wide Web. The World Wide Web is a client/server application that helps the user access various HTML pages available at various Internet sites. Its function is to display documents and to make links between items of information available. The user then chooses which links to follow as the user pursues a course through various World Wide Web pages. An Internet World Wide Web site refers to an entity connected to the Internet that supports World Wide Web communications and/or World Wide Web files. A typical web site will include an HTTP server and one or more HTML pages (sometimes referred to as World Wide Web pages).

A web site is usually configured to include a home page and a plurality of HTML pages that may each contain one or more hyperlinks. As a user clicks on one hyperlink in the home page, the user is transported to another HTML page. Further pages may have, for example, a hyperlink that returns the user to the home page or a hyperlink that forwards the user to a subsequent page.

A player can access a global computer network such as the Internet from a personal computer. It is contemplated in accordance with the present invention that other devices, such as a mobile telephone or pager can also access the Internet and allow information transfer as will be described with reference to a personal computer. The remainder of this application will refer to, for simplicity, a personal computer by which a player transmits and receives information regarding information transfer.

As shown in FIG. 1, a personal computer preferably contains a microprocessor 110 that executes instructions from its Read Only Memory (ROM) and during such execution, the microprocessor 110 temporarily stores and accesses information from the Random Access Memory (RAM). The microprocessor 110 is also attached to a remote video display driver and remote monitor 116. The remote monitor 116 displays outcome data of one or more slot machines 160, 161, 162 that has been

0000000000000000000000000000000000

received from a casino server 140 via the Internet 120. Also connected to the microprocessor 110 of the personal computer is a mouse 112, keyboard 114 and/or other accessories that a player may use to input information such as play preferences. Assuming that the player has accessed a casino web site 130 that allows interactive information transfer, the information entered by the player is available to a casino server 140 and one or more slot machines 160, 161, 162 therein.

The remote personal computer and microprocessor 110, as displayed in FIG. 1, is communicatively connected to the casino server 140 and attached data storage unit 150 via the casino web site 130. The casino web site 130 is a remote wagering network controlled by the casino server 140. It is contemplated in accordance with the present invention that the web site 130 may be owned and operated by agencies or organizations separate from the casino; however, it is preferable that the casino server 140 and the casino web site 130 are in constant communication to allow players access to the outcome information emanating from the slot machines 160, 161, 162 within the casino.

At least one slot machine 160 within the casino communicates outcome data to the casino server 140 for transfer to the casino web site 130 and to the player. Outcome data shall be understood to include information including, but not limited to, all game-related activity such as the position of the reels of a slot machine 160, an indication of whether the player has won or lost and the corresponding amount won or lost. This data is passed from the individual slot machine 160 to the casino server 140 and subsequently to the casino web site 130 and player.

Each slot machine 160 has unique identifying characteristics that allow the casino server 140 to distinguish the outcome data as being sent from a particular machine and to store and transmit that data with reference to that particular machine. The casino, via its web site 130, asks the player the type of game from which the player wishes to receive information. For example, the player may choose to be connected to a gaming machine such as a video or mechanical slot machine, video blackjack machine, video poker machine, video roulette machine, video keno machine or a video bingo machine. The slot machines 160, 161, 162 in FIG. 1 may be replaced with any of these other types of gaming machines. After receiving







After gaining access to this address/site, a player will, in order to be able to receive information directed from a casino, need to register, as shown at step 215 of FIG. 2a, with the web site 130. One preferred method of obtaining identification from a player is to create a user identification (“User ID”) number or name and password as commonly performed on many web sites. In order to create such a User ID, the web site 130 will preferably require the input of many pieces of information from a registering participant, such as name, address, telephone number, preferred game or games, preferred bet per game, credit card number, type of credit card, expiration date and other pertinent information. After receiving this information, the casino web site 130 notifies the casino server 140 of the player’s desire to obtain a transfer of information. The casino server 140 processes the information, stores the relevant identification information within the casino player database 155 and assigns a User ID and password to the new player. The User ID and password serve as an identification tag for a player to allow the player to easily and repeatedly enter and receive information associated with the casino web site 130 of the present invention. Once the User ID and password are accepted by the Web Administrator, the player is able to access the games.

Specifically, after accessing the casino web site 130 (or another authorized site designated to handle logging into a casino or gaming establishment), a player can enter or “log in” to, at step 220, the gaming area by providing, for example, the User ID and password, as described above. After receiving this information, the casino web site 130 will process the information, store the relevant identification information within the casino player database 155 and assign a User ID and password to the new player.

The User ID and password serve as an identification tag for a player to allow the player to easily and repeatedly enter and receive information associated with the web site 130. Once the User ID and password are accepted, the player is given an option of the type of game to play, the amount to wager, etc. The player will indicate the preferred options using one or more selection buttons, mouse 112 inputs and/or keyboard 114 inputs. The player must also provide a means to pay for the information to be transferred from the casino to the player via the Internet 120. One preferred method that a player can ensure payment for the information transfer is to

arrange an account with the casino or other organization that maintains control over the web site 130. A player wishing to arrange such an account can deposit funds with the casino in person or arrange for a line of credit in the casino account. Each time a player participates in a game by asking for an information transfer, the casino will deduct from the casino account the amount of the fee for the game or portion of a game that is played. Payouts for winning outcomes can be added to the casino account. It is also contemplated in accordance with the present invention that the session database 154 and remote wagering database 152 can “remember” the amount wagered, lost, and won for a player during a particular gaming session and only remove or add to a casino account, depending on the random outcomes, at the end of a gaming session.

As an initial step in the operation of the present embodiment, the remote player may add funds to the player’s credit balance. Funds are supplied to the player account via a credit card that the player has previously submitted to the casino. It is also contemplated in accordance with the present invention that a player can enter a credit card number via input means such as a mouse 112 and/or a keyboard 114 each time that the player begins an information retrieval session.

The casino web site 130 transmits the player identifying information at step 225 of FIG. 2a to the casino server 140. The casino server 140 accesses the record in the casino player database 155, at step 230, containing the received player identification information. The server proceeds to access the credit availability and credit information of the player. The microprocessor of the server 140 authenticates the player identification number, which involves searching the casino player database 155 for the record having the received player identification numbers. If no record exists in the casino player database 155 having the particular player identification number, then the remote player is rejected and play is disallowed. If the casino player database 155 identifies a record containing the player identification number, the remote player is accepted for remote play.

Once the credit and payment information is accessed, the player is then notified, at step 235 of FIG. 2b, to initiate remote play. Preferably, the remote monitor 116 displays a prompting message requesting that the remote player input the

CHICAGO 137574v1 47079-00077

play preferences. Specifically, the casino server 140 transmits a signal to the casino web site 130 that displays, on the remote monitor 116, the prompting message.

In order to respond to the prompting message and place a specific wager on the outcome of the random number generation, the player communicates, at step 240,  
5 one or more preferences to the casino regarding the slot machine 160 event. The remote player proceeds to enter play preferences via a mouse 112 input, a keyboard 114 input, a touch pen input, a touch screen input or other input means commonly known in the art. For example, the player may determine the amount of wager wished to be placed on a random event or the type of reward that player wishes to receive, if  
10 any. It is also contemplated in accordance with the present invention that the player may decide, via the Internet 120, what types of bonus prizes are desired and/or the different types of options to pursue if or when a bonus round is initiated.

The play preferences and other identifying information are then transmitted from the casino web site 130 and to the casino server 140 for inclusion in the  
15 appropriate field of the player's record in the session database 154, as shown at step 245 of FIG. 2b. Having received the play preferences, the casino server 140 accesses the record in the remote wagering database 152 and proceeds to enter the player identification into the appropriate field of that record.

After creating a record in the remote wagering database 152, the casino server  
20 140 searches the slot machine database 153 for a slot machine(s) that matches (or most nearly matches) the play preferences, at step 250, inputted by the player. The casino then selects that machine(s) for use. The casino server 140 may select slot machines that are currently in use by live players (players physically present at the slot machines) of those that are not in use by live players. The selected slot  
25 machine(s) randomly generates outcome data for transmission to the casino server 140. When generating the outcome data for a remote player, the slot machine does not visually display the outcome data or the generation of the outcome data on the slot machine itself. Such visual presentations by the slot machine itself are reserved for live players physically present at the slot machine.

30 The casino server 140 receives the outcome data from the selected slot machines. Where the outcome data includes the visual representation of the outcome, *i.e.* reel positions, the reel positions may be received by the casino server 140.

Furthermore, so that the casino server 140 can identify which of the received outcome data corresponds to which slot machine, the slot machine transmits the outcome data, at step 255, along with its machine identification number. In alternate embodiments, other machine identifying information may be transmitted with the outcome data.

5           The casino server 140 proceeds to transmit, at step 260, the outcome data for those selected slot machines to the casino web site 130 and then to the player. In the present embodiment, the remote monitor 116 displays the outcome, such as the reel positions (or card values for video poker machines) as well as the payout information, if any. Furthermore, the remote monitor 116 may simulate play of the selected slot  
10          machine based upon the received outcome data by generating a graphical display of spinning reels in the same manner as a conventional slot machine. In alternate embodiments employing gaming devices other than slot machines, the remote monitor 116 similarly may simulate play, such as the graphical dealing of cards or spinning of a roulette wheel.

15           The casino server 140 updates the remote player's credit balance field that is also displayed on the remote monitor 116. After the server updates the player's credit balance field at the casino server 140, the casino server 140 determines whether the player has sufficient funds remaining to allow continued play. After this determination, the casino server 140 relays information through the casino web site  
20          130 to the player and inquires if further play is desired, at step 265 of FIG. 2b. If sufficient funds remain, the remote monitor 116 displays a request by asking the player if continued play is desired and, if so, returns to step 235 and asks for play preferences. If the credit balance contains insufficient funds, the server directs the remote monitor 116 to display a message indicating a lack of funds. In response, the  
25          player may discontinue remote play or the player may deposit additional funds or authorize further credit for continued play, as described above. If play is discontinued for either of the above reasons, the player "cashes out" at step 270 and terminate the play session.

30           The steps for cashing out when remote play is completed are as follows. After indicating that the player no longer wishes to play or does not have further funds to continue playing, the casino web site 130 transmits the player identification number to the casino server 140. The casino server 140 receives the player identification

number and proceeds to access the record in the casino player database 155 corresponding to that player identification number. The casino server 140 proceeds to transmit the value stored in the credit balance field to the credit card.

In one embodiment, the slot machine communicates only the payout information to the casino server 140, which in turn generates a visual representation of an outcome representative of that payout information. For example, outcome data of plus ten coins for one particular type of machine may be represented by a generated visual display on the remote monitor 116. The casino server 140 generates the accurate visual representation of the outcome by accessing the slot machine database 153 and, based upon the machine identification information transmitted with the payout, the record for that slot machine. A payout structure for that particular slot machine is maintained within the record in the appropriate field. The payout structure, like the payout table in the slot machine, correlates the payout received from the slot machine to a possible set of reel positions.

For example, when the reels of a slot machine reveal "cherry-cherry-cherry," the slot machine may have determined that the player should receive a payout of ten coins. The slot machine then communicates to the casino server 140 that the game outcome revealed that the player should receive a payout of ten coins. The casino server 140, by accessing the payout structure, correlates the payout of ten coins back into a set of reel positions and generates a visual representation of the outcome of the slot machine for transmission to the remote monitor 116 for display to the player. Because several reel positions may correspond to the same payout, the casino server 140 may generate reel positions different than the outcome that was visually displayed on the slot machine.

In another embodiment, no live outcome data is received from a slot machine. Instead, the casino server 140 selects historical outcome data previously stored in a field of the slot machine database 153. As when live outcome data is used, the casino server 140 selects the historical outcome data based upon the play preferences. As will be apparent to one skilled in the art, use of historical outcome data is particularly advantageous to slot machine and casino owners. Each portion of outcome data received by the casino server 140 has inherent value. This value stems, at least in part, from the resources required to generate the outcome data, such as capital

investment in each slot machine, electricity to operate the slot machine, and wear on the slot machine from each play. Thus, by storing the outcome data in the historical outcome data field, the system is able to reuse outcome data.

In alternative embodiments, the historical outcome data includes the historical outcome of at least one play of a gaming device, the historical payout of at least one play of a gaming device, or both the historical outcome and historical payout. Where the historical outcome data includes both historical outcome and historical payout information, the casino server merely retrieves the historical outcome data and the system proceeds, as described above, based upon this information. Where the historical outcome data is just historical outcomes, the casino server 140 determines the historical payout information by accessing the payout structure.

Where the historical outcome data includes only historical payout information, the casino server 140 may first generate a visual representation of the corresponding historical outcome. As with a live outcome, the casino server 140 generates a visual representation of the historical outcome by accessing the payout structure and, based upon the known historical payout, generating the visual representation data for transmission to the player. The system proceeds based upon the historical payout and the generated visual representation data.

In yet another embodiment of the present invention, the gaming player enters credit card information into appropriate locations on the casino's web site 130. To accept wagers, the operator of the web site 130 establishes an account commonly referred to as a Merchant Account. The Merchant Account enables Internet businesses to engage in credit card transactions. Similar to traditional storefront businesses, a contractual agreement is made between a commercial bank and the web site business. This agreement allows the web site 130 to accept major credit cards (*i.e.*, Visa, Master Card, Diner's Club, American Express, etc.). To ensure the privacy of the credit card user, the web site 130 of the present invention employs security software designed specifically to safeguard and protect users that engage in credit card transactions via the World Wide Web. Further, if a credit card is used inappropriately on the web site 130 of the present invention, the appropriate credit card owner (and/or credit card) is reimbursed for the losses incurred relating to

03630301 30430301

charges on the site. To avoid credit card fraud, specific measures commonly known in the art are taken to protect the credit card user.

A player deciding to participate in the information transfer is asked to fill out a series of items to verify his or her credit card information. The player fills in items, for example, that ask for the player's name, credit card number, type of credit card, credit card number, credit card expiration date, address, telephone number and other pertinent information. Once the information has been transmitted and verified, the player is able to participate in the information transfer and the Merchant Account software enables the player's charges to be deposited from the credit card account into the business checking account of the Administrator of the Web site 130.

When an outcome is returned to the player, the casino web site 130 inquires if the player would like to continue playing, "cash out" any winnings, or perhaps participate in a bonus game if such is offered by the game. It is noted in accordance with the present invention that the types of slot machines are widely varied and many options that are not discussed here can nonetheless be transferred to the player via the Internet 120 in order to provide more entertainment to the player.

Preferably, the Merchant Account will allow a transaction with a player's credit card only at the end of a gaming session. It is impractical and costly for the Merchant Account to conduct a transaction each time the player participates in the information transfer and each time the player receives a payoff from the information transfer outcome.

It is also contemplated in accordance with a further embodiment of the present invention that the casino server 140 itself (or an auxiliary server coupled to the casino server 140) can generate random numbers and corresponding outcomes to be transmitted to a player via a global computer network. In other words, the game software for the slot machine 160 or other type of gaming machine would reside in the casino server 140. Also, the server 140 and casino web site 130 may be associated with a gaming establishment other than a casino.

Each of these embodiments and obvious variations thereof is contemplated as falling within the spirit and scope of the claimed invention, which is set forth in the following claims:









00307-700000

21. A remote computer located outside a gaming establishment, said remote computer comprising:

means for receiving information identifying a plurality of local gaming machines each engaged in play within said gaming establishment;

5 means for transmitting data from selecting at least a one of said plurality of local gaming machines for information transfer;

means for receiving a text or graphical outcome resulting from a play of said selected local gaming machines; and

means for generating a payout if said outcome meets predetermined criteria.

10

22. A method for transferring gaming data on a global computer network comprising:

receiving player identification information from outside of a gaming establishment;

15 analyzing said player identification information;

requesting player input regarding a random event;

receiving and analyzing said input;

generating a random number within said gaming establishment;

interpreting said random number to determine a text or graphical outcome; and

20 transmitting said outcome to a player through said global computer network.

23. The method of Claim 22, wherein said random event takes place in a microprocessor within a gaming machine located within said gaming establishment.

25 24. The method of Claim 22, wherein said random event takes place in a microprocessor within a gaming establishment server.

25. The method of Claim 22, wherein said global computer network is the Internet.

30

26. A method of receiving transferred data via a global computer network, comprising:





receiving said outcome data at said gaming server; and  
transmitting said outcome data from said gaming server to said gaming site for  
display to said player on said remote terminal in text or graphical form.

SECRET



Fig. 1

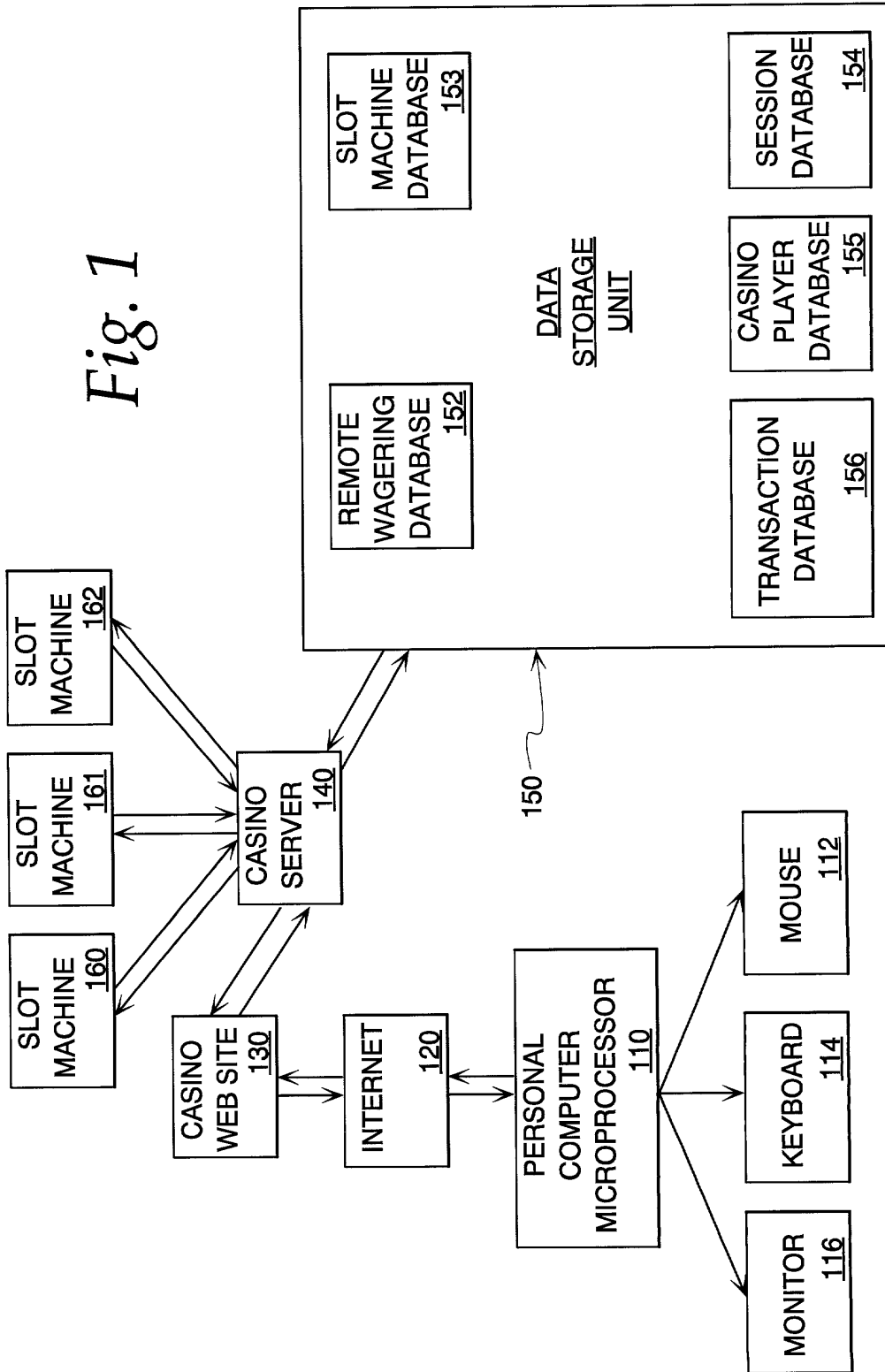



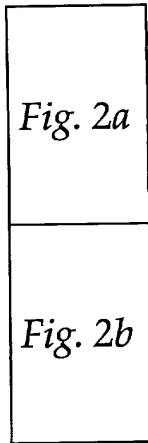

Fig. 2a

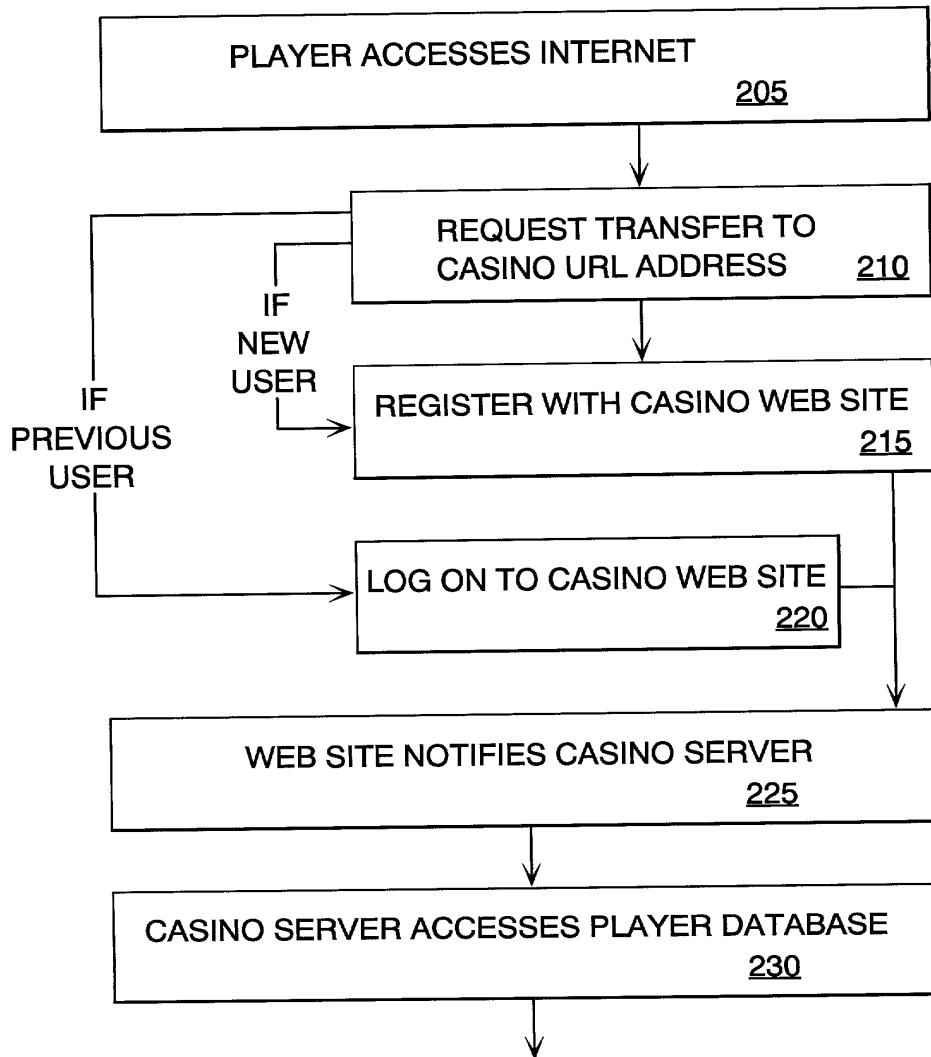

EXHIBIT 2003-000000

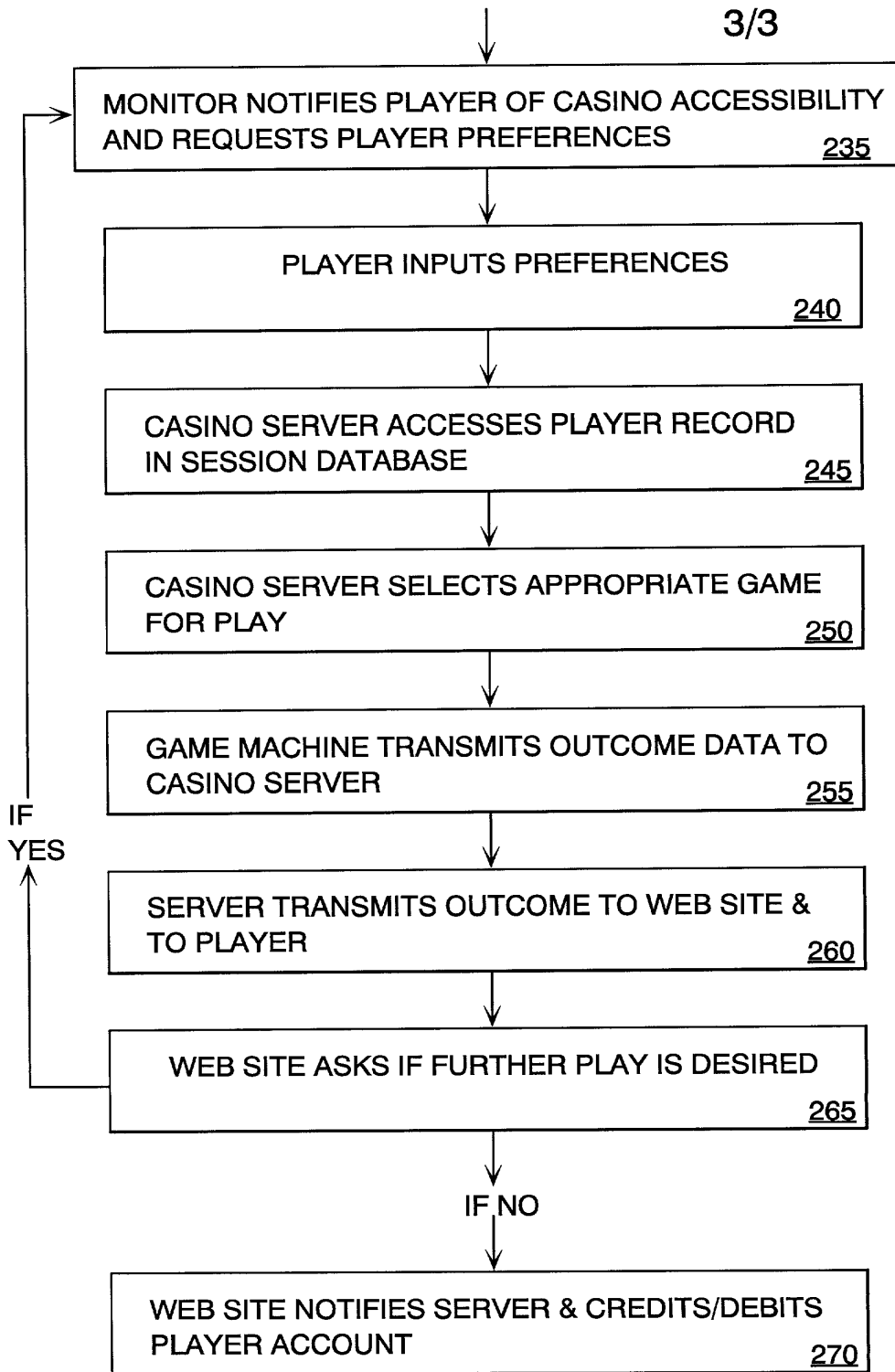

Fig. 2b

**RULES 63 AND 67 (37 C.F.R. 1.63 and 1.67)  
DECLARATION AND POWER OF ATTORNEY**

FOR UTILITY/DESIGN/CIP/PCT NATIONAL APPLICATIONS

As a below named inventor, I hereby declare that:

My residence, post office address and citizenship are as stated below next to my name; and

I believe that I am the original, first and sole inventor of the subject matter which is claimed and for which a patent is sought on the invention entitled: **Method of Transferring Gaming Data on a Global Computer Network**, the specification of which: (mark only one)

- (a) is attached hereto.  
 (b) was filed on \_\_ as Application Serial No. \_\_ and was amended on \_\_\_\_ (if applicable)  
 (c) was filed as PCT International Application No. PCT/ \_\_\_\_ on \_\_\_\_ and was amended on \_\_\_\_ (if applicable).  
 (d) was filed on \_\_ as Application Serial No. \_\_ and was issued a Notice of Allowance on \_\_\_\_.  
 (e) was filed on \_\_ and bearing attorney docket number

I hereby state that I have reviewed and understand the contents of the above identified specification, including the claims as amended by any amendment referred to above or as allowed as indicated above.

I acknowledge the duty to disclose all information known to me to be material to the patentability of this application as defined in 37 CFR ' 1.56. If this is a continuation-in-part (CIP) application, insofar as the subject matter of each of the claims of this application is not disclosed in the prior United States application in the manner provided by the first paragraph of 35 U.S.C. ' 112, I acknowledge the duty to disclose to the Office all information known to me to be material to patentability of the application as defined in 37 CFR ' 1.56 which became available between the filing date of the prior application and the national or PCT international filing date of this application.

I hereby claim foreign priority benefits under 35 U.S.C. ' 119/365 of any foreign application(s) for patent or inventor's certificate listed below and have also identified below any foreign application for patent or inventor's certificate filed by me or my assignee disclosing the subject matter claimed in this application and having a filing date (1) before that of the application on which my priority is claimed or, (2) if no priority is claimed, before the filing date of this application:

PRIOR FOREIGN PATENTS

<u>Number</u>	<u>Country</u>	<u>Month/Day/Year Filed</u>	<u>Date first laid- open or Published</u>	<u>Date patented or Granted</u>		<u>Priority Claimed</u>	
				<u>Yes</u>	<u>No</u>	<u>Yes</u>	<u>No</u>
NONE							

I hereby claim the benefit under 35 U.S.C. ' 120/365 of any United States application(s) listed below and PCT international applications listed above or below:

PRIOR U.S. OR PCT APPLICATIONS

<u>Application No. (series code/serial no.)</u>	<u>Month/Day/Year Filed</u>	<u>Status(pending, abandoned, patented)</u>
NONE		

I hereby appoint:

TIMOTHY G. ACKERMANN, Reg. No. 44,493	GERALD H. GLANZMAN, Reg. No. 25,035	DANIEL G. NGUYEN, Reg. No. 42,933
THOMAS E. ANDERSON, Reg. No. 37,063	J. KEVIN GRAY, Reg. No. 37,141	SPENCER C. PATTERSON, Reg. No. 43,849
BENJAMIN J. BAI, Reg. No. 43,481	STEVEN R. GREENFIELD, Reg. No. 38,166	RUSSELL N. RIPPAMONTI, Reg. No. 39,521
MICHAEL J. BLANKSTEIN, Reg. No. 37,097	JOSHUA A. GRISWOLD, Reg. No. 46,310	ROSS T. ROBINSON, Reg. No. 47,031
MARY JO BOLDINGH, Reg. No. 34,713	J. PAT HEPTIG, Reg. No. 40,643	STEPHEN G. RUDISILL,, Reg. No. 20,087
MARGARET A. BOULWARE, Reg. No. 28,708	SHARON A. ISRAEL, Reg. No. 41,867	HOLLY L. RUDNICK, Reg. No. 43,065
ARTHUR J. BRADY, Reg. No. 42,356	JOHN R. KIRK JR., Reg. No. 24,477	J.L. JENNIE SALAZAR, Reg. No. 45,065
MATTHEW O. BRADY, Reg. No. 44,554	PAUL R. KITCH, Reg. No. 38,206	KEITH W. SAUNDERS, Reg. No. 41,462
DANIEL J. BURNHAM, Reg. No. 39,618	TIMOTHY M. KOWALSKI, Reg. No. 44,192	JERRY R. SELINGER, Reg. No. 26,582
THOMAS L. CANTRELL, Reg. No. 20,849	JAMES F. LEA III, Reg. No. 41,143	Zachary J. Smolinski, Registration No. 47,100
RONALD B. COOLLEY, Reg. No. 27,187	HSIN-WEI LUANG, Reg. No. 44,213	GARY B. SOLOMON, Reg. No. 44,347
THOMAS L. CRISMAN, Reg. No. 24,846	ROBERT W. MASON, Reg. No. 42,848	WAYNE O. STACY, Reg. No. 45,125
STUART D. DWORK, Reg. No. 31,103	ROGER L. MAXWELL, Reg. No. 31,855	STEVE Z. SZCZEPANSKI, Reg. No. 27,957
WILLIAM F. ESSER, Reg. No. 38,053	ROBERT A. McFALL, Reg. No. 28,968	ANDRE M. SZUWALSKI, Reg. No. 35,701
ROGER J. FRENCH, Reg. No. 27,786	STEVEN T. McDONALD, Reg. No. 45,999	ALAN R. THIELE, Reg. No. 30,694
JANET M. GARETTO, Reg. No. 42,568	LISA H. MEYERHOFF, Reg. No. 36,869	TAMSEN VALOIR, Reg. No. 41,417
JOHN C. GATZ, Reg. No. 41,774	STANLEY R. MOORE, Reg. No. 26,958	RAYMOND VAN DYKE, Reg. No. 34,746
RUSSELL J. GENET, Reg. No. 42,571	RICHARD J. MOURA, Reg. No. 34,883	BRIAN D. WALKER, Reg. No. 37,751
	MARK V. MULLER, Reg. No. 37,509	GERALD T. WELCH, Reg. No. 30,332
	P. WESTON MUSSELMAN JR. Reg No. 31,644	HAROLD N. WELLS, Reg. No. 26,044
		WILLIAM D. WIESE, Reg. No. 45,217

all of the firm of **JENKENS & GILCHRIST, a Professional Corporation**, 1445 Ross Avenue, Suite 3200, Dallas, Texas 75202-2799, as my attorneys and/or agents, with full power of substitution and revocation, to prosecute this application, provisionals thereof, continuations, continuations-in-part, divisionals, appeals, reissues, substitutions, and extensions thereof and to transact all business in the United States Patent and Trademark Office connected therewith, to appoint any individuals under an associate power of attorney and to file and prosecute any international patent application filed thereon before any international authorities, and I hereby authorize them to act and rely on instructions from and communicate directly with the person/assignee/attorney/firm/organization who/which first sent this case to them and by whom/which I hereby declare that I have consented after full disclosure to be represented unless/until I instruct them in writing to the contrary.







116  
A  
12/21  
12-22-00

ISSUE SLIP STAPLE AREA (for additional cross references)

POSITION	INITIALS	ID NO.	DATE
FEE DETERMINATION			
O.I.P.E. CLASSIFIER		25	103000
FORMALITY REVIEW	AM	396	12/21/00
RESPONSE FORMALITY REVIEW			

INDEX OF CLAIMS

- ✓ ..... Rejected
- ..... Allowed
- (Through numeral)... Canceled
- | ..... Restricted
- N ..... Non-elected
- I ..... Interference
- A ..... Appeal
- O ..... Objected

Claim	Final	Original	Date
1			
2			
3			
4			
5			
6			
7			
8			
9			
10			
11			
12			
13			
14			
15			
16			
17			
18			
19			
20			
21			
22			
23			
24			
25			
26			
27			
28			
29			
30			
31			
32			
33			
34			
35			
36			
37			
38			
39			
40			
41			
42			
43			
44			
45			
46			
47			
48			
49			
50			

Claim	Final	Original	Date
51			
52			
53			
54			
55			
56			
57			
58			
59			
60			
61			
62			
63			
64			
65			
66			
67			
68			
69			
70			
71			
72			
73			
74			
75			
76			
77			
78			
79			
80			
81			
82			
83			
84			
85			
86			
87			
88			
89			
90			
91			
92			
93			
94			
95			
96			
97			
98			
99			
100			

Claim	Final	Original	Date
101			
102			
103			
104			
105			
106			
107			
108			
109			
110			
111			
112			
113			
114			
115			
116			
117			
118			
119			
120			
121			
122			
123			
124			
125			
126			
127			
128			
129			
130			
131			
132			
133			
134			
135			
136			
137			
138			
139			
140			
141			
142			
143			
144			
145			
146			
147			
148			
149			
150			

BEST AVAILABLE COPY

If more than 150 claims or 10 actions  
staple additional sheet here

(LEFT INSIDE)



jc957 U.S. PTO  
10/16/00

Customer No. 23932

10-17-00

A

Patent Application  
Docket No. 47079-00077

IN THE UNITED STATES PATENT AND TRADEMARK OFFICE

In re patent application of: Shridhar P. Joshi

For: Method of Transferring Gaming Data on a Global Computer Network

jc915 U.S. PTO  
09/28/00  
10/16/00

BOX PATENT APPLICATION  
Assistant Commissioner  
for Patents  
Washington, D.C. 20231

CERTIFICATE OF MAILING BY EXPRESS MAIL
"EXPRESS MAIL" Mailing Label No. <b>EL705449427US</b>
Date of Deposit: <b>October 16, 2000</b>
I hereby certify that this paper or fee is being deposited with the U.S. Postal Service "Express Mail Post Office to Addressee" service under 37 CFR 1.10 on the date indicated above and is addressed to the Assistant Commissioner for Patents, Washington, D.C. 20231
Type or Print Name: <i>Jackie Arnold</i>
Signature: <i>Jackie Arnold</i>

Sir:

PATENT APPLICATION TRANSMITTAL LETTER

Transmitted herewith for filing, please find the following:

- Specification, claims and abstract of the above-referenced patent application (total of 25 pages)
- 3 sheet(s) of drawing(s) ( formal/  informal).
- Combined Declaration and Power of Attorney (signed).
- An Assignment of the invention to: WMS Gaming Inc.
- A verified statement claiming small entity status under 37 CFR 1.9 and 1.27.
- Other (specify): Information Disclosure Statement; Form PTO-1449; references, and Acknowledgment postcard .
- This application is a:
  - Continuation
  - Divisional
  - Continuation-In-Part

of prior copending parent application Serial No. filed on now pending.

Please amend the application to insert the following line in the beginning of the specification:

--This application is a Continuation of prior application Serial No. filed on  
, now pending.--

In the event that a petition to extend time under 37 CFR 1.136 is necessary in the parent application to maintain copendency for this application, a petition for an extension of the necessary time to maintain copendency is hereby requested for the parent application and the Commissioner is hereby authorized to debit our Account Number 10-0447 for the necessary fees.

The filing fee has been calculated as shown below:

	<b>NO. FILED</b>	<b>NO. EXTRA</b>	<b>RATE</b>	<b>FEE</b>
<b>BASIC FEE</b>				<b>\$710</b>
<b>TOTAL CLAIMS</b>	<b>36-20</b>	<b>16</b>	<b>\$18</b>	<b>288</b>
<b>INDEPENDENT CLAIMS</b>	<b>7-3</b>	<b>4</b>	<b>\$80</b>	<b>320</b>
<b>MULTIPLE DEPENDENT CLAIM(S) PRESENTED</b>			<b>\$260</b>	
<b>TOTAL FEES: ___</b>				<b>\$1,318</b>
<b>Deduct one-half of fee for Small Entity</b>				<b>=</b>
<b>ASSIGNMENT RECORDAL FEE</b>			<b>\$40</b>	<b>40</b>
<b>TOTAL AMOUNT DUE:</b>				<b>\$1,358</b>

- Please charge my Deposit Account No. 10-0447 in the amount of \$
- Check in the amount of \$1,358.00 is attached. Please charge any deficiency or credit any overpayment to Deposit Account No. 10-0447.
- The Commissioner is hereby authorized to charge payment of the following fees during the pendency of this application or credit any overpayment to Deposit Account No. 10-0447.
  - Any patent application processing fees under 37 CFR 1.17 and under 37 CFR 1.20(d).
  - The issue fee set in 37 CFR 1.18 at or before mailing of the Notice of Allowance, pursuant to 37 CFR 1.311(b).
  - Any filing fees under 37 CFR 1.16 including fees for presentation of extra claims.

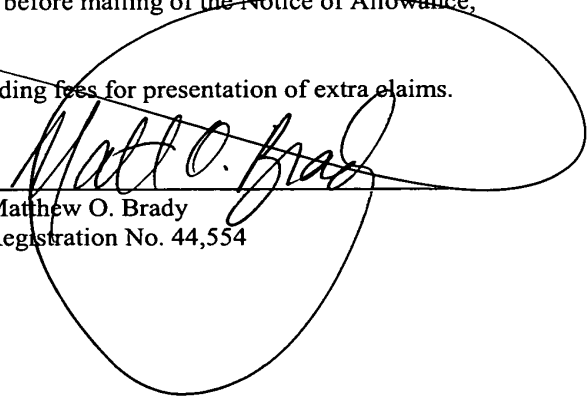
  
 Matthew O. Brady  
 Registration No. 44,554

JENKENS & GILCHRIST  
 3200 Fountain Place  
 1445 Ross Avenue  
 Dallas, Texas 75202-2799  
 312/425-8512 (Direct)  
 312/425-3909 (Fax)

Fig. 1

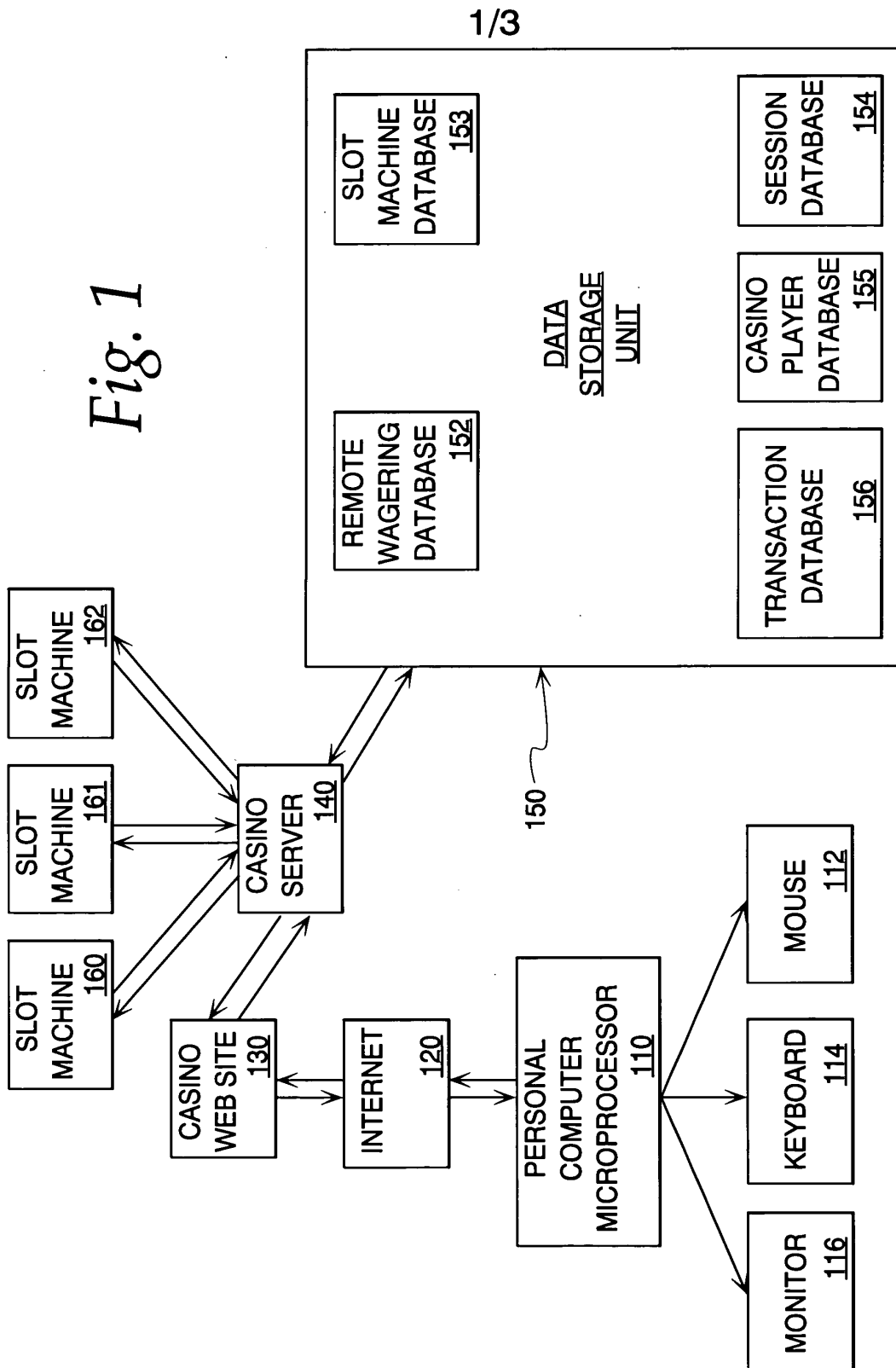



3/3

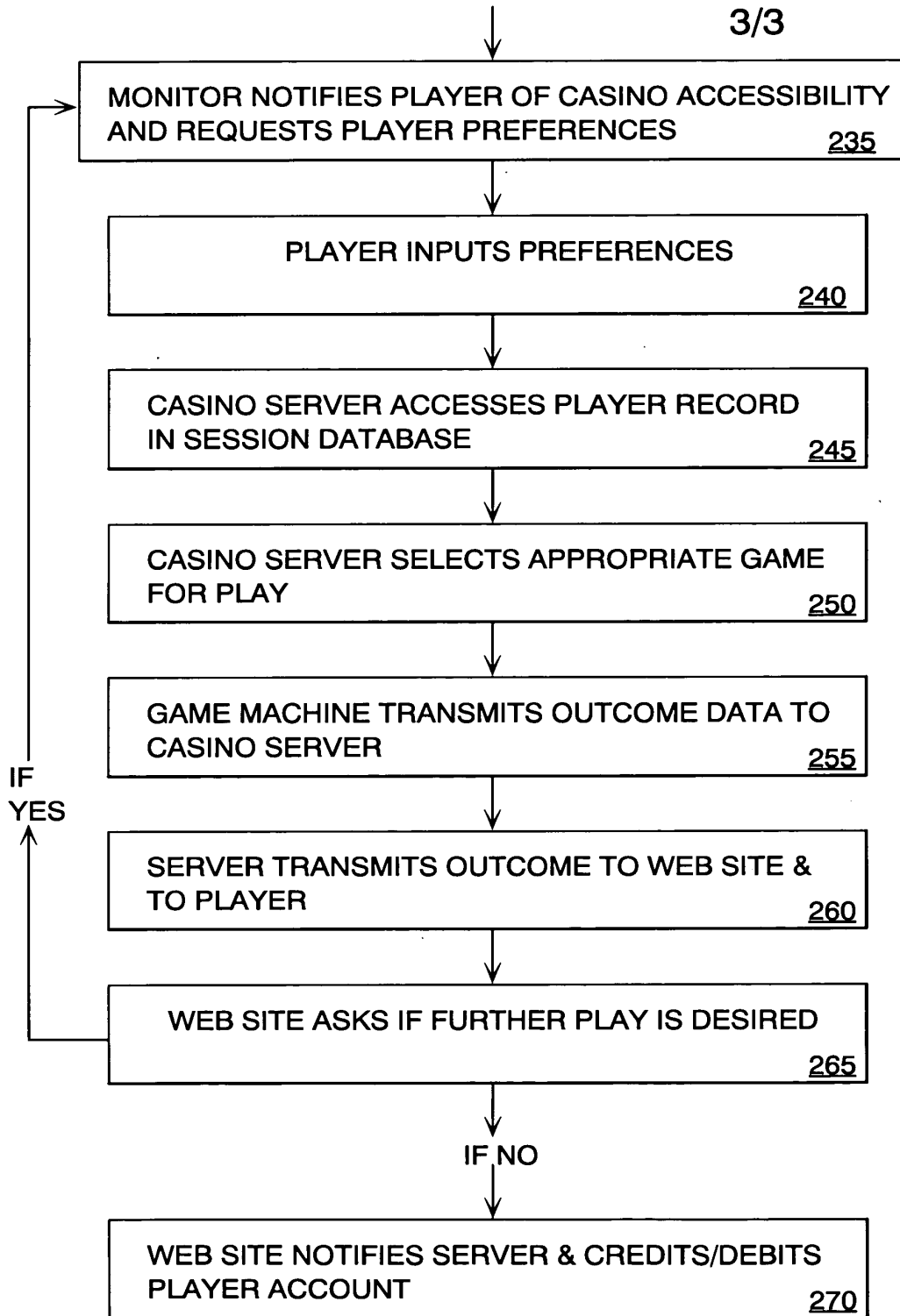

Fig. 2b

Customer No. 23932

PATENT  
47079-00077

---

---

**APPLICATION FOR UNITED STATES LETTERS PATENT**

**For**

**METHOD OF TRANSFERRING GAMING DATA ON A  
GLOBAL COMPUTER NETWORK**

**By**

**Shridhar P. Joshi**

---

---

EXPRESS MAIL MAILING LABEL

NUMBER: EL705449427US

DATE: October 16, 2000

I hereby certify that this paper or fee is being deposited with the United States Postal Service "EXPRESS MAIL POST OFFICE TO ADDRESSEE" service under 37 C.F.R. 1.10 on the date indicated above and is addressed to: Assistant Commissioner for Patents, Washington D.C. 20231.

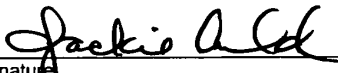
  
Signature \_\_\_\_\_

**METHOD OF TRANSFERRING GAMING DATA ON A  
GLOBAL COMPUTER NETWORK**

**FIELD OF THE INVENTION**

5 The present invention relates generally to gaming machines and, more particularly, to a method of transferring data from a gaming establishment to a player at a remote site via a global computer network.

**BACKGROUND OF THE INVENTION**

10 Gaming machines, such as slot machines, video poker machines and the like, have been a cornerstone of the gaming industry for several years. Generally, the popularity of such machines with players is dependent on the likelihood (or perceived likelihood) of winning money and the intrinsic entertainment value of the machine relative to other available gaming options. Shrewd operators consequently strive to employ the most entertaining and exciting machines available because such machines attract frequent play and hence increase profitability to the operator. Accordingly, in  
15 the competitive gaming machine industry, there is a continuing need for gaming machine manufacturers to produce different methods to attract frequent play by enhancing the entertainment value and excitement associated with the game.

20 Many game players want to be able to play gaming machines much more frequently than they are currently able to do. Such players are often limited because of the requisite travel required to attend casinos or other legal gaming establishments located in select portions of the United States. The involvedness, cost and inconvenience of a player being forced to travel to a gaming establishment severely limits the amount of gambling excursions that a player can assume. Furthermore, since these excursions are infrequent, a gaming player is often forced to spend as  
25 much time gambling as possible during the excursion because such a player may not have the means to return to the gaming establishment for several months or years. There is continuing need for a gaming player to be able to gamble more frequently or for a shorter period time than is currently available and to be able to do so from a location remote to the gaming establishment.





data and telephone networks. Computers connected to the Internet can exchange information with any other connected computer. The backbone of the Internet is founded on various sets of major telephone conduits and switches that exist across the world. These communications conduits are designed to move large volumes of data traffic at extremely high rates of speed.

Each of the major conduits referred to above terminates at a router, which is a large, fast switch that sorts the large volumes of data. Each router is connected to additional, local routing devices. Local routing devices, called "points of presence" provide local Internet access. For example, an Internet termination router located in Chicago may have point of presence routers connected in, for example, Milwaukee and Indianapolis. A router is able to connect as many point of presence routers as the capacity of the switching systems and the Internet will permit.

In addition to point of presence routers, commercial Internet exchanges and global Internet exchanges also connect to the routers. These exchanges transfer data between Internet service providers, both nationally and internationally. When data originates on one U.S. Internet service provider with a destination on another U.S. long distance provider, the data is first routed to the commercial Internet exchange where it makes the transfer between providers.

Personal computers typically connect to a local point of presence router through a local Internet carrier. A local Internet carrier obtains a direct line to the point of presence router and provides a modem or other connection by which a personal computer user achieves Internet access. When the personal computer connects to the modem of the local Internet carrier, the local Internet carrier switches the home computer to the point of presence router, which in turn connects the personal computer to the Internet.

Another method of connecting computers to the Internet is by direct connection through a local area network (LAN) to the point of presence. Multiple personal computers can be connected to a single LAN, which connects to the point of presence through a leased data line. The computers connected to the LAN receive and transmit data to the point of the presence through the LAN.

Attached to most LANs are a variety of different servers including the File Server and the Hypertext Transport Protocol ("HTTP") server. The File Server

connects to the LAN and contains the common data files used by the personal computers, the LAN and other servers. An HTTP server is a particular type of server that processes incoming and outgoing data written according to a certain Internet communication protocol, called hypertext transport protocol.

5 As described above, the Internet is able to interconnect every computer on the Internet with every other computer on the Internet. An Internet site typically includes certain data files (called "web pages" that are a part of the World Wide Web) in its File Server. The Internet site HTTP server makes those pages available to other computers on the Internet. An HTTP Server that makes World Wide Web pages  
10 available on the Internet usually includes a so-called "home page," the starting point for outside users to navigate through the underlying World Wide Web pages serviced by the HTTP Server. These World Wide Web pages are written in a special World Wide Web language called Hypertext Markup Language ("HTML"). When a personal computer user wants to view a home page, it can do so by requesting that  
15 data over the Internet. In response, the requisite LAN retrieves the web page data from its File Server and instructs its HTTP Server to transmit the data, addressed via the Internet, to the personal computer that requested the information. The data generally travels from the local leased link to the point of presence router near the location of the LAN, through the Internet, through the point of presence router near  
20 the requesting personal computer, through the local Internet carrier, and into the modem of the requesting personal computer.

*SUB B2*

~~Transmission Control Protocol/Internet Protocol ("TCP/IP") controls transmission of data on the Internet to provide World Wide Web communication to users. To insure that data is sent to and received by the appropriate receiver on the  
25 Internet, every device communicating on the Internet is assigned a unique address called an Internet Protocol ("IP") address. Elements of the IP address identify the location in the network that a device is connected. Other parts of the IP address identify the specific device. The IP address number has a three-digit element that identifies the state of the resident and an additional seven digits, three of which  
30 identify the local exchange of the resident and four digits that specifically identify the home of the resident. The IP address is presently a thirty-two bit binary address, readily processed by computers, but cumbersome for use by human users.~~

09535503 4016100

Consequently, the majority of IP addresses are assigned mnemonics to make them more "user friendly." The mnemonic consists of two parts: a host name and a domain name. It is this representation of the IP address that is commonly used by Internet users to access Web sites. Conventionally within the World Wide Web, the mnemonic "WWW" is used to represent the host name. The remaining portion of the mnemonic represents the domain or network where the host resides. For example, www.uspto.gov, identifies a host named "www" in the domain (network) "uspto.gov".

The standard protocol used by Internet components to address each other and usually is used as a Uniform Resource Locator ("URL"). This terminology appears as the opening element in the web site address. For example, http://www.uspto.gov, the Uniform Resource Locator indicates that the request is for "http" formatted data, (i.e., a web page as opposed to, for example, an electronic mail message). The home page for the data resides on the "www" HTTP server on the "uspto.gov" LAN (or domain). The name of the file (to be found most likely in the file server supported by the uspto.gov LAN) is "homepage.html."

Once a user has received an "HTML" formatted file corresponding to a web page, the text of the displayed file may prompt the user to request additional information contained in different web page files. The prompts are referred to as "hypertext" and usually show up on a home page (or other web page) in a different color than normal text, thus distinguishing them as hypertext links. Hypertext links in a document allow a reader to jump from one object to another object within the document and to objects outside of the document. Hyperlinks between documents create an informational space with no formal pathways. Hyperlinks may include any kind of hypertext or other hypermedia link connecting one HTML page to another HTML page in the currently displayed web site or in some external web site. HTML is the computer language used to "compose" and represent information on a web page. By clicking a mouse on the hypertext, the user is automatically "transported" from a current web page to a new web page linked to that hypertext.

For example, the master list server sends the request to a Domain Name Server ("DNS") responsible for handling calls to this address. If the DNS recognizes the call, then an affirmation is sent to the master list server that directs the call to the

091606501 433599

server storing the particular home page. When the hypertext is selected, the browser requests a connection to the HTTP server hosting the file and it also requests from the HTTP server the file identified by the URL address. If the HTTP server accepts the connection requested by the browser, the HTTP server proceeds to transmit the requested file back to the browser. Once the browser receives the requested file, it delivers or presents the content of the file to the requesting user.

One of the most popular mediums for browsing the Internet is the World Wide Web. The World Wide Web is a client/server application that helps the user access various HTML pages available at various Internet sites. Its function is to display documents and to make links between items of information available. The user then chooses which links to follow as the user pursues a course through various World Wide Web pages. An Internet World Wide Web site refers to an entity connected to the Internet that supports World Wide Web communications and/or World Wide Web files. A typical web site will include an HTTP server and one or more HTML pages (sometimes referred to as World Wide Web pages).

A web site is usually configured to include a home page and a plurality of HTML pages that may each contain one or more hyperlinks. As a user clicks on one hyperlink in the home page, the user is transported to another HTML page. Further pages may have, for example, a hyperlink that returns the user to the home page or a hyperlink that forwards the user to a subsequent page.

A player can access a global computer network such as the Internet from a personal computer. It is contemplated in accordance with the present invention that other devices, such as a mobile telephone or pager can also access the Internet and allow information transfer as will be described with reference to a personal computer. The remainder of this application will refer to, for simplicity, a personal computer by which a player transmits and receives information regarding information transfer.

As shown in FIG. 1, a personal computer preferably contains a microprocessor 110 that executes instructions from its Read Only Memory (ROM) and during such execution, the microprocessor 110 temporarily stores and accesses information from the Random Access Memory (RAM). The microprocessor 110 is also attached to a remote video display driver and remote monitor 116. The remote monitor 116 displays outcome data of one or more slot machines 160, 161, 162 that has been

00000011000000

received from a casino server 140 via the Internet 120. Also connected to the microprocessor 110 of the personal computer is a mouse 112, keyboard 114 and/or other accessories that a player may use to input information such as play preferences. Assuming that the player has accessed a casino web site 130 that allows interactive information transfer, the information entered by the player is available to a casino server 140 and one or more slot machines 160, 161, 162 therein.

The remote personal computer and microprocessor 110, as displayed in FIG. 1, is communicatively connected to the casino server 140 and attached data storage unit 150 via the casino web site 130. The casino web site 130 is a remote wagering network controlled by the casino server 140. It is contemplated in accordance with the present invention that the web site 130 may be owned and operated by agencies or organizations separate from the casino; however, it is preferable that the casino server 140 and the casino web site 130 are in constant communication to allow players access to the outcome information emanating from the slot machines 160, 161, 162 within the casino.

At least one slot machine 160 within the casino communicates outcome data to the casino server 140 for transfer to the casino web site 130 and to the player. Outcome data shall be understood to include information including, but not limited to, all game-related activity such as the position of the reels of a slot machine 160, an indication of whether the player has won or lost and the corresponding amount won or lost. This data is passed from the individual slot machine 160 to the casino server 140 and subsequently to the casino web site 130 and player.

Each slot machine 160 has unique identifying characteristics that allow the casino server 140 to distinguish the outcome data as being sent from a particular machine and to store and transmit that data with reference to that particular machine. The casino, via its web site 130, asks the player the type of game from which the player wishes to receive information. For example, the player may choose to be connected to a gaming machine such as a video or mechanical slot machine, video blackjack machine, video poker machine, video roulette machine, video keno machine or a video bingo machine. The slot machines 160, 161, 162 in FIG. 1 may be replaced with any of these other types of gaming machines. After receiving

information from the player regarding the type of game desired to be played, the casino web site 130 transmits this information to the casino server 140 at the casino.

5 The slot machine 160 generally possesses myriad random gaming events in which a player has the opportunity to place a wager on the outcome of the random event. Each slot machine 160 includes a microprocessor, clock, and an operating system. The microprocessor executes the instructions for playing the slot machine 160 and includes a random number generator. Random Access Memory (RAM) temporarily stores information passed on to it by the microprocessor.

10 The slot machine 160 is initiated by inserting a coin or coins, using electronic credit or by other methods commonly known in the art. The game begins in response to the player activating a starting device (*e.g.*, by pulling a lever or pushing a button). This activation causes the microprocessor within the slot machine 160 to set the reels in motion and the random number generator randomly selects a number that corresponds to a given outcome. The microprocessor stops the reels to display the symbols corresponding to the selected random number outcome. If the slot machine 15 160 is of the video type, simulated reels are rotated and stopped to place symbols on the reels in visual association with a video display area.

20 In response to the activation of the slot machine 160, the microprocessor's random number generator generates a random number that corresponds to a given outcome. In accordance with one embodiment of the present invention, a remote player, via the Internet 120 or other global computer network, places a wager on the outcome of this random number generation. The casino then transmits the outcome of the random number generation in either a predetermined format or a format selected by the player.

25 The casino server 140 also has a microprocessor, a clock and an operating system associated therewith. The microprocessor of the server executes instruction of a program stored in read-only memory (ROM) and the microprocessor temporarily stores information in RAM. In order to communicate with the remote slot machine 160, each slot machine 160 is connected to the casino server 140. The server includes 30 one or more communications ports to connect with each slot machine 160 and also to the network in order to transmit data to the casino's web site 130 and eventually to the player. Furthermore, the microprocessor of the casino server 140 is united to a data

storage unit 150 comprising a transaction processor 156, a casino player database 155, a session database 154, remote wagering database 152 and a gaming machine database 153.

5 In general, the transaction processor 156 manages the contents of the data storage unit. The casino player database 155 includes multiple records having multiple fields of information related to the identification of each player. The fields within each record include, for example, name, social security number, player identification number, address, telephone number(s), credit card type, number and expiration date, credit balance and other requisite information.

10 The session database 154 comprises multiple records, each record relating to a remote play session. One field in each such record contains the player identification number and other fields include the type of slot machine 160 and its identification number to be accessed, the outcome(s), the bet per game, reel positions and payout. It is contemplated in accordance with the present invention that a remote player may  
15 choose multiple slot machines 160, 161, 162 for remote information transfer.

The remote wagering database 152 includes multiple records, each of which corresponds to a different slot machine 160. Each record comprises fields including the terminal location, the player identification for players using the machine, start and end times for each player and gaming machine type. The information recorded in this  
20 database 152 is used to determine the amount of time that each slot machine 160 is used.

The gaming machine database 153 also contains information regarding each gaming machine. Each slot machine is, as noted above, associated with particular identifying information and this information is stored in one field of the slot machine  
25 database 153. Other fields include machine type, machine denomination, maximum coins allowed, outcome data, and for reel games, reel position and payout. This database 153 allows the casino server 140 to easily search and discover the different machines that possess different types of games.

The general operation of the system according to one embodiment of the  
30 present invention is discussed in connection with FIGS. 2a, 2b. After accessing the Internet 120, at step 205 of FIG. 2a, the player can simply request transfer to a casino's URL address or web site 130, in step 210, in the manner described above.

After gaining access to this address/site, a player will, in order to be able to receive information directed from a casino, need to register, as shown at step 215 of FIG. 2a, with the web site 130. One preferred method of obtaining identification from a player is to create a user identification ("User ID") number or name and password as commonly performed on many web sites. In order to create such a User ID, the web site 130 will preferably require the input of many pieces of information from a registering participant, such as name, address, telephone number, preferred game or games, preferred bet per game, credit card number, type of credit card, expiration date and other pertinent information. After receiving this information, the casino web site 130 notifies the casino server 140 of the player's desire to obtain a transfer of information. The casino server 140 processes the information, stores the relevant identification information within the casino player database 155 and assigns a User ID and password to the new player. The User ID and password serve as an identification tag for a player to allow the player to easily and repeatedly enter and receive information associated with the casino web site 130 of the present invention. Once the User ID and password are accepted by the Web Administrator, the player is able to access the games.

Specifically, after accessing the casino web site 130 (or another authorized site designated to handle logging into a casino or gaming establishment), a player can enter or "log in" to, at step 220, the gaming area by providing, for example, the User ID and password, as described above. After receiving this information, the casino web site 130 will process the information, store the relevant identification information within the casino player database 155 and assign a User ID and password to the new player.

The User ID and password serve as an identification tag for a player to allow the player to easily and repeatedly enter and receive information associated with the web site 130. Once the User ID and password are accepted, the player is given an option of the type of game to play, the amount to wager, etc. The player will indicate the preferred options using one or more selection buttons, mouse 112 inputs and/or keyboard 114 inputs. The player must also provide a means to pay for the information to be transferred from the casino to the player via the Internet 120. One preferred method that a player can ensure payment for the information transfer is to



arrange an account with the casino or other organization that maintains control over the web site 130. A player wishing to arrange such an account can deposit funds with the casino in person or arrange for a line of credit in the casino account. Each time a player participates in a game by asking for an information transfer, the casino will deduct from the casino account the amount of the fee for the game or portion of a game that is played. Payouts for winning outcomes can be added to the casino account. It is also contemplated in accordance with the present invention that the session database 154 and remote wagering database 152 can "remember" the amount wagered, lost, and won for a player during a particular gaming session and only remove or add to a casino account, depending on the random outcomes, at the end of a gaming session.

As an initial step in the operation of the present embodiment, the remote player may add funds to the player's credit balance. Funds are supplied to the player account via a credit card that the player has previously submitted to the casino. It is also contemplated in accordance with the present invention that a player can enter a credit card number via input means such as a mouse 112 and/or a keyboard 114 each time that the player begins an information retrieval session.

The casino web site 130 transmits the player identifying information at step 225 of FIG. 2a to the casino server 140. The casino server 140 accesses the record in the casino player database 155, at step 230, containing the received player identification information. The server proceeds to access the credit availability and credit information of the player. The microprocessor of the server 140 authenticates the player identification number, which involves searching the casino player database 155 for the record having the received player identification numbers. If no record exists in the casino player database 155 having the particular player identification number, than the remote player is rejected and play is disallowed. If the casino player database 155 identifies a record containing the player identification number, the remote player is accepted for remote play.

Once the credit and payment information is accessed, the player is then notified, at step 235 of FIG. 2b, to initiate remote play. Preferably, the remote monitor 116 displays a prompting message requesting that the remote player input the

play preferences. Specifically, the casino server 140 transmits a signal to the casino web site 130 that displays, on the remote monitor 116, the prompting message.

In order to respond to the prompting message and place a specific wager on the outcome of the random number generation, the player communicates, at step 240, one or more preferences to the casino regarding the slot machine 160 event. The remote player proceeds to enter play preferences via a mouse 112 input, a keyboard 114 input, a touch pen input, a touch screen input or other input means commonly known in the art. For example, the player may determine the amount of wager wished to be placed on a random event or the type of reward that player wishes to receive, if any. It is also contemplated in accordance with the present invention that the player may decide, via the Internet 120, what types of bonus prizes are desired and/or the different types of options to pursue if or when a bonus round is initiated.

The play preferences and other identifying information are then transmitted from the casino web site 130 and to the casino server 140 for inclusion in the appropriate field of the player's record in the session database 154, as shown at step 245 of FIG. 2b. Having received the play preferences, the casino server 140 accesses the record in the remote wagering database 152 and proceeds to enter the player identification into the appropriate field of that record.

After creating a record in the remote wagering database 152, the casino server 140 searches the slot machine database 153 for a slot machine(s) that matches (or most nearly matches) the play preferences, at step 250, inputted by the player. The casino then selects that machine(s) for use. The casino server 140 may select slot machines that are currently in use by live players (players physically present at the slot machines) of those that are not in use by live players. The selected slot machine(s) randomly generates outcome data for transmission to the casino server 140. When generating the outcome data for a remote player, the slot machine does not visually display the outcome data or the generation of the outcome data on the slot machine itself. Such visual presentations by the slot machine itself are reserved for live players physically present at the slot machine.

The casino server 140 receives the outcome data from the selected slot machines. Where the outcome data includes the visual representation of the outcome, *i.e.* reel positions, the reel positions may be received by the casino server 140.

Furthermore, so that the casino server 140 can identify which of the received outcome data corresponds to which slot machine, the slot machine transmits the outcome data, at step 255, along with its machine identification number. In alternate embodiments, other machine identifying information may be transmitted with the outcome data.

5           The casino server 140 proceeds to transmit, at step 260, the outcome data for those selected slot machines to the casino web site 130 and then to the player. In the present embodiment, the remote monitor 116 displays the outcome, such as the reel positions (or card values for video poker machines) as well as the payout information, if any. Furthermore, the remote monitor 116 may simulate play of the selected slot  
10 machine based upon the received outcome data by generating a graphical display of spinning reels in the same manner as a conventional slot machine. In alternate embodiments employing gaming devices other than slot machines, the remote monitor 116 similarly may simulate play, such as the graphical dealing of cards or spinning of a roulette wheel.

15           The casino server 140 updates the remote player's credit balance field that is also displayed on the remote monitor 116. After the server updates the player's credit balance field at the casino server 140, the casino server 140 determines whether the player has sufficient funds remaining to allow continued play. After this determination, the casino server 140 relays information through the casino web site  
20 130 to the player and inquires if further play is desired, at step 265 of FIG. 2b. If sufficient funds remain, the remote monitor 116 displays a request by asking the player if continued play is desired and, if so, returns to step 235 and asks for play preferences. If the credit balance contains insufficient funds, the server directs the remote monitor 116 to display a message indicating a lack of funds. In response, the  
25 player may discontinue remote play or the player may deposit additional funds or authorize further credit for continued play, as described above. If play is discontinued for either of the above reasons, the player "cashes out" at step 270 and terminate the play session.

30           The steps for cashing out when remote play is completed are as follows. After indicating that the player no longer wishes to play or does not have further funds to continue playing, the casino web site 130 transmits the player identification number to the casino server 140. The casino server 140 receives the player identification

number and proceeds to access the record in the casino player database 155 corresponding to that player identification number. The casino server 140 proceeds to transmit the value stored in the credit balance field to the credit card.

5 In one embodiment, the slot machine communicates only the payout information to the casino server 140, which in turn generates a visual representation of an outcome representative of that payout information. For example, outcome data of plus ten coins for one particular type of machine may be represented by a generated visual display on the remote monitor 116. The casino server 140 generates the accurate visual representation of the outcome by accessing the slot machine database  
10 153 and, based upon the machine identification information transmitted with the payout, the record for that slot machine. A payout structure for that particular slot machine is maintained within the record in the appropriate field. The payout structure, like the payout table in the slot machine, correlates the payout received from the slot machine to a possible set of reel positions.

15 For example, when the reels of a slot machine reveal "cherry-cherry-cherry," the slot machine may have determined that the player should receive a payout of ten coins. The slot machine then communicates to the casino server 140 that the game outcome revealed that the player should receive a payout of ten coins. The casino server 140, by accessing the payout structure, correlates the payout of ten coins back  
20 into a set of reel positions and generates a visual representation of the outcome of the slot machine for transmission to the remote monitor 116 for display to the player. Because several reel positions may correspond to the same payout, the casino server 140 may generate reel positions different than the outcome that was visually displayed on the slot machine.

25 In another embodiment, no live outcome data is received from a slot machine. Instead, the casino server 140 selects historical outcome data previously stored in a field of the slot machine database 153. As when live outcome data is used, the casino server 140 selects the historical outcome data based upon the play preferences. As  
30 will be apparent to one skilled in the art, use of historical outcome data is particularly advantageous to slot machine and casino owners. Each portion of outcome data received by the casino server 140 has inherent value. This value stems, at least in part, from the resources required to generate the outcome data, such as capital

investment in each slot machine, electricity to operate the slot machine, and wear on the slot machine from each play. Thus, by storing the outcome data in the historical outcome data field, the system is able to reuse outcome data.

In alternative embodiments, the historical outcome data includes the historical  
5 outcome of at least one play of a gaming device, the historical payout of at least one play of a gaming device, or both the historical outcome and historical payout. Where the historical outcome data includes both historical outcome and historical payout information, the casino server merely retrieves the historical outcome data and the system proceeds, as described above, based upon this information. Where the  
10 historical outcome data is just historical outcomes, the casino server 140 determines the historical payout information by accessing the payout structure.

Where the historical outcome data includes only historical payout information, the casino server 140 may first generate a visual representation of the corresponding historical outcome. As with a live outcome, the casino server 140 generates a visual  
15 representation of the historical outcome by accessing the payout structure and, based upon the known historical payout, generating the visual representation data for transmission to the player. The system proceeds based upon the historical payout and the generated visual representation data.

In yet another embodiment of the present invention, the gaming player enters  
20 credit card information into appropriate locations on the casino's web site 130. To accept wagers, the operator of the web site 130 establishes an account commonly referred to as a Merchant Account. The Merchant Account enables Internet businesses to engage in credit card transactions. Similar to traditional storefront businesses, a contractual agreement is made between a commercial bank and the web  
25 site business. This agreement allows the web site 130 to accept major credit cards (*i.e.*, Visa, Master Card, Diner's Club, American Express, etc.). To ensure the privacy of the credit card user, the web site 130 of the present invention employs security software designed specifically to safeguard and protect users that engage in credit card transactions via the World Wide Web. Further, if a credit card is used  
30 inappropriately on the web site 130 of the present invention, the appropriate credit card owner (and/or credit card) is reimbursed for the losses incurred relating to

charges on the site. To avoid credit card fraud, specific measures commonly known in the art are taken to protect the credit card user.

5 A player deciding to participate in the information transfer is asked to fill out a series of items to verify his or her credit card information. The player fills in items, for example, that ask for the player's name, credit card number, type of credit card, credit card number, credit card expiration date, address, telephone number and other pertinent information. Once the information has been transmitted and verified, the player is able to participate in the information transfer and the Merchant Account software enables the player's charges to be deposited from the credit card account into  
10 the business checking account of the Administrator of the Web site 130.

When an outcome is returned to the player, the casino web site 130 inquires if the player would like to continue playing, "cash out" any winnings, or perhaps participate in a bonus game if such is offered by the game. It is noted in accordance with the present invention that the types of slot machines are widely varied and many  
15 options that are not discussed here can nonetheless be transferred to the player via the Internet 120 in order to provide more entertainment to the player.

Preferably, the Merchant Account will allow a transaction with a player's credit card only at the end of a gaming session. It is impractical and costly for the Merchant Account to conduct a transaction each time the player participates in the  
20 information transfer and each time the player receives a payoff from the information transfer outcome.

It is also contemplated in accordance with a further embodiment of the present invention that the casino server 140 itself (or an auxiliary server coupled to the casino server 140) can generate random numbers and corresponding outcomes to be  
25 transmitted to a player via a global computer network. In other words, the game software for the slot machine 160 or other type of gaming machine would reside in the casino server 140. Also, the server 140 and casino web site 130 may be associated with a gaming establishment other than a casino.

Each of these embodiments and obvious variations thereof is contemplated as  
30 falling within the spirit and scope of the claimed invention, which is set forth in the following claims:

**WHAT IS CLAIMED IS:**

1. A method for transferring gaming data to a remote terminal located outside a gaming establishment comprising:

5 receiving at said remote terminal information from a gaming site on a global computer network identifying a plurality of gaming machines at said gaming establishment;

transmitting data from said remote terminal selecting at least one of said gaming machines for remote information transfer;

10 receiving at said remote terminal a text or graphical outcome resulting from a play of said at least one of said gaming machines; and  
generating a payout if said outcome meets predetermined criteria.

15 2. The method of Claim 1, wherein said selected gaming machine comprising a slot machine and wherein said outcome includes a reel position.

3. The method of Claim 1, wherein said step of receiving information includes receiving information selecting at least two of said plurality of gaming machines for remote play.

20 4. The method of claim 3 wherein said step of receiving information includes receiving a gaming machine identifier.

25 5. The method of claim 3 wherein said step of receiving information includes receiving a gaming machine type.

6. The method of claim 3 wherein said step of receiving information includes receiving player preferences.

30 7. The method of claim 1 wherein said selected gaming machine comprises a video poker machine including a display for displaying a poker hand.

000001450060

8. The method of claim 1 wherein said outcome comprises information identifying the value of said payout; and

further comprising the step of using said payout information to simulate a display of said outcome at said remote location.

5

9. The method of claim 1 wherein said selected gaming machine comprises a slot machine and wherein said outcome comprises information identifying a reel position of said gaming machine; and

further comprising the step of using said outcome information to display said reel position at said remote location.

10

10. The method of claim 1 and further including the steps of receiving a player identifier; and

transmitting said player identifier for identification of said player.

15

11. A remote computer for the remote play of a local gaming machine located within a gaming establishment, the remote computer being located outside said gaming establishment, said remote computer comprising:

a microprocessor;

memory connected to said microprocessor and including instructions for controlling said microprocessor; and

20

said microprocessor being operative with said instructions in said memory to: receive information identifying a plurality of local gaming machines located within said gaming establishment,

transmit data selecting at least one of said plurality of local gaming machines for remote play,

25

receive a text or graphical outcome resulting from a local play of said selected gaming machines, and

generate a payout if said outcome meets predetermined criteria.

30

12. The remote computer of claim 11 wherein said selected gaming machine comprises a slot machine and wherein said outcome includes a reel position.



- 5 13. The remote computer of claim 11 wherein said operation of receiving information includes receiving information selecting at least two of said plurality of gaming machines for remote play.
- 14. The remote computer of claim 11 wherein said operation of receiving information includes receiving a gaming machine identifier.
- 10 15. The remote computer of claim 14 wherein said operation of receiving information includes receiving a gaming machine type.
- 16. The remote computer of claim 14 wherein said operation of receiving information includes receiving player preferences.
- 15 17. The remote computer of claim 11 wherein said selected gaming machine comprises a video poker machine including a display for displaying a poker hand.
- 18. The remote computer of claim 11 wherein said outcome comprises data identifying the value of said payout; and  
20 further comprising the operation of using said payout data to simulate a display of said outcome at said remote location.
- 19. The remote computer of claim 11 wherein said outcome comprises information identifying a reel position of said selected gaming machine; and  
25 further comprising the operation of using said outcome data to display said reel position at said remote location.
- 20. The remote computer of claims 11 further including the operations of:  
30 receiving a player identifier; and  
transmitting said player identifier for identification of said player.



CHICAGO 137574v1 47079-00077

5 accessing a global computer network from outside a gaming establishment;  
inputting identification information into said global computer network;  
gaining access to a server within said gaming establishment;  
requesting the generation of a random number, said random number being  
generated from within said gaming establishment; and  
receiving a text or graphical outcome of said random number generation via  
said global computer network.

10 27. The method of Claim 26, wherein said global computer network is the  
Internet.

28. The method of Claim 26, wherein said generation of said random number is  
accomplished at a gaming machine within said gaming establishment.

15 29. The method of Claim 26, wherein said generation of said random number is  
accomplished at a gaming establishment server.

20 30. The method of Claim 26, wherein the step of receiving is accomplished via  
said global computer network.

31. The method of Claim 26, wherein the step of receiving is accomplished  
through the Internet.

25 32. An interactive site on a global computer network comprising:  
a page including one or more game choices to allow a player to participate in a  
remote random event;  
data means to input data;  
outcome means to receive text or graphical outcomes of a remote random  
event; and  
30 notification means to notify said player of said outcomes.

CHICAGO "FOSS" 030306

33. The interactive web site of Claim 32, wherein said page is an Internet-based World Wide Web page.

34. The interactive web site of Claim 32, wherein said remote random event occurs in a slot machine.

35. A remote gaming method comprising:  
accessing, via a remote terminal, a gaming site on a global computer network connected to said remote terminal;  
10 providing, via said remote terminal, personal identification information to said gaming site;  
selecting, via said remote terminal, a game of chance located at a gaming establishment for remote play, said remote terminal being located outside said gaming establishment;  
15 placing, via said remote terminal, a wager for playing said selected game; and receiving randomly-generated text or graphical outcome data at said remote terminal for said selected game, said outcome data being generated by one of a gaming server and a gaming machine at said gaming establishment and relayed to said gaming site.

36. A remote gaming method using a gaming server, a remote terminal, and a gaming site on a global computer network, said gaming server being located at a gaming establishment, said remote terminal being located outside said gaming establishment, said gaming site being provided on said global computer network, the method comprising:

25 receiving, at said gaming server, personal identification information, game selection information, and wager information from a player accessing said gaming site via said remote terminal, said remote terminal being connected to said global computer network;

30 randomly generating outcome data at one of said gaming server and a gaming machine communicatively coupled to said gaming server, said outcome data being generated for a game selected according to said game selection information, said gaming machine being located at said gaming establishment;

receiving said outcome data at said gaming server; and  
transmitting said outcome data from said gaming server to said gaming site for  
display to said player on said remote terminal in text or graphical form.

Add  
B3

CHICAGO 137574v1 47079-00077



**RULES 63 AND 67 (37 C.F.R. 1.63 and 1.67)  
DECLARATION AND POWER OF ATTORNEY**

FOR UTILITY/DESIGN/CIP/PCT NATIONAL APPLICATIONS

As a below named inventor, I hereby declare that:

My residence, post office address and citizenship are as stated below next to my name; and

I believe that I am the original, first and sole inventor of the subject matter which is claimed and for which a patent is sought on the invention entitled: **Method of Transferring Gaming Data on a Global Computer Network**, the specification of which: (mark only one)

- (a) is attached hereto.  
 (b) was filed on \_\_\_ as Application Serial No. \_\_\_ and was amended on \_\_\_\_\_ (if applicable)  
 (c) was filed as PCT International Application No. PCT/\_\_\_\_\_ on \_\_\_\_\_ and was amended on \_\_\_\_\_ (if applicable).  
 (d) was filed on \_\_\_ as Application Serial No. \_\_\_ and was issued a Notice of Allowance on \_\_\_\_\_.  
 (e) was filed on \_\_\_ and bearing attorney docket number

I hereby state that I have reviewed and understand the contents of the above identified specification, including the claims as amended by any amendment referred to above or as allowed as indicated above.

I acknowledge the duty to disclose all information known to me to be material to the patentability of this application as defined in 37 CFR ' 1.56. If this is a continuation-in-part (CIP) application, insofar as the subject matter of each of the claims of this application is not disclosed in the prior United States application in the manner provided by the first paragraph of 35 U.S.C. ' 112, I acknowledge the duty to disclose to the Office all information known to me to be material to patentability of the application as defined in 37 CFR ' 1.56 which became available between the filing date of the prior application and the national or PCT international filing date of this application.

I hereby claim foreign priority benefits under 35 U.S.C. ' 119/365 of any foreign application(s) for patent or inventor's certificate listed below and have also identified below any foreign application for patent or inventor's certificate filed by me or my assignee disclosing the subject matter claimed in this application and having a filing date (1) before that of the application on which my priority is claimed or, (2) if no priority is claimed, before the filing date of this application:

PRIOR FOREIGN PATENTS

<u>Number</u>	<u>Country</u>	<u>Month/Day/Year Filed</u>	<u>Date first laid- open or Published</u>	<u>Date patented or Granted</u>		<u>Priority Claimed</u>	
				<u>Yes</u>	<u>No</u>	<u>Yes</u>	<u>No</u>
NONE							

I hereby claim the benefit under 35 U.S.C. ' 120/365 of any United States application(s) listed below and PCT international applications listed above or below:

PRIOR U.S. OR PCT APPLICATIONS

<u>Application No. (series code/serial no.)</u>	<u>Month/Day/Year Filed</u>	<u>Status(pending, abandoned, patented)</u>
NONE		

I hereby appoint:

- |  |  |   |
|--|--|---|
| TIMOTHY G. ACKERMANN, Reg. No. 44,493  | GERALD H. GLANZMAN, Reg. No. 25,035    | DANIEL G. NGUYEN, Reg. No. 42,933             |
| THOMAS E. ANDERSON, Reg. No. 37,063    | J. KEVIN GRAY, Reg. No. 37,141         | SPENCER C. PATTERSON, Reg. No. 43,849         |
| BENJAMIN J. BAI, Reg. No. 43,481       | STEVEN R. GREENFIELD, Reg. No. 38,166  | RUSSELL N. RIPPAMONTI, Reg. No. 39,521        |
| MICHAEL J. BLANKSTEIN, Reg. No. 37,097 | JOSHUA A. GRISWOLD, Reg. No. 46,310    | ROSS T. ROBINSON, Reg. No. 47,031             |
| MARY JO BOLDINGH, Reg. No. 34,713      | J. PAT HEPTIG, Reg. No. 40,643         | STEPHEN G. RUDISILL,, Reg. No. 20,087         |
| MARGARET A. BOULWARE, Reg. No. 28,708  | SHARON A. ISRAEL, Reg. No. 41,867      | HOLLY L. RUDNICK, Reg. No. 43,065             |
| ARTHUR J. BRADY, Reg. No. 42,356       | JOHN R. KIRK JR., Reg. No. 24,477      | J.L. JENNIE SALAZAR, Reg. No. 45,065          |
| MATTHEW O. BRADY, Reg. No. 44,554      | PAUL R. KITCH, Reg. No. 38,206         | KEITH W. SAUNDERS, Reg. No. 41,462            |
| DANIEL J. BURNHAM, Reg. No. 39,618     | TIMOTHY M. KOWALSKI, Reg. No. 44,192   | JERRY R. SELINGER, Reg. No. 26,582            |
| THOMAS L. CANTRELL, Reg. No. 20,849    | JAMES F. LEA III, Reg. No. 41,143      | Zachary J. Smolinski, Registration No. 47,100 |
| RONALD B. COOLLEY, Reg. No. 27,187     | HSIN-WEI LUANG, Reg. No. 44,213        | GARY B. SOLOMON, Reg. No. 44,347              |
| THOMAS L. CRISMAN, Reg. No. 24,846     | ROBERT W. MASON, Reg. No. 42,848       | WAYNE O. STACY, Reg. No. 45,125               |
| STUART D. DWORK, Reg. No. 31,103       | ROGER L. MAXWELL, Reg. No. 31,855      | STEVE Z. SZCZEPANSKI, Reg. No. 27,957         |
| WILLIAM F. ESSER, Reg. No. 38,053      | ROBERT A. McFALL, Reg. No. 28,968      | ANDRE M. SZUWALSKI, Reg. No. 35,701           |
| ROGER J. FRENCH, Reg. No. 27,786       | STEVEN T. McDONALD, Reg. No. 45,999    | ALAN R. THIELE, Reg. No. 30,694               |
| JANET M. GARETTO, Reg. No. 42,568      | LISA H. MEYERHOFF, Reg. No. 36,869     | TAMSEN VALOIR, Reg. No. 41,417                |
| JOHN C. GATZ, Reg. No. 41,774          | STANLEY R. MOORE, Reg. No. 26,958      | RAYMOND VAN DYKE, Reg. No. 34,746             |
| RUSSELL J. GENET, Reg. No. 42,571      | RICHARD J. MOURA, Reg. No. 34,883      | BRIAN D. WALKER, Reg. No. 37,751              |
|  | MARK V. MULLER, Reg. No. 37,509        | GERALD T. WELCH, Reg. No. 30,332              |
|  | P. WESTON MUSSELMAN JR. Reg No. 31,644 | HAROLD N. WELLS, Reg. No. 26,044              |
|  |  | WILLIAM D. WIESE, Reg. No. 45,217             |

all of the firm of **JENKENS & GILCHRIST, a Professional Corporation**, 1445 Ross Avenue, Suite 3200, Dallas, Texas 75202-2799, as my attorneys and/or agents, with full power of substitution and revocation, to prosecute this application, provisionals thereof, continuations, continuations-in-part, divisionals, appeals, reissues, substitutions, and extensions thereof and to transact all business in the United States Patent and Trademark Office connected therewith, to appoint any individuals under an associate power of attorney and to file and prosecute any international patent application filed thereon before any international authorities, and I hereby authorize them to act and rely on instructions from and communicate directly with the person/assignee/attorney/firm/organization who/which first sent this case to them and by whom/which I hereby declare that I have consented after full disclosure to be represented unless/until I instruct them in writing to the contrary.



Please address all correspondence and direct all telephone calls to:

Michael J. Blankstein, Esq.  
Jenkins & Gilchrist, P.C.  
1445 Ross Avenue, Suite 3200  
Dallas, Texas 75202-2799  
312/425-3900  
312/425-3909 (fax)

I hereby declare that all statements made herein of my own knowledge are true and that all statements made on information and belief are believed to be true; and further that these statements were made with the knowledge that willful false statements and the like so made are punishable by fine or imprisonment, or both, under Section 1001 of Title 18 of the United States Code, and that such willful false statements may jeopardize the validity of the application or any patent issued thereon.

NAMED INVENTOR(S)

1	Shridhar P. Joshi		10/13/00
	<b>Full Name</b>	<b>Inventor's Signature</b>	<b>Date</b>
	7636 Kenton Avenue Skokie, Illinois 60076		India
	<b>Residence</b> (city, state, country)		<b>Citizenship</b>
	7636 Kenton Avenue Skokie, Illinois 60076		
	<b>Post Office Address</b> (include zip code)		

PATENT APPLICATION SERIAL NO. \_\_\_\_\_

U.S. DEPARTMENT OF COMMERCE  
PATENT AND TRADEMARK OFFICE  
FEE RECORD SHEET

10/20/2000 MAHMEDI 00000005 09688501

01 FC:101	710.00	OP
02 FC:102	320.00	OP
03 FC:103	288.00	OP

12/19/2000 EEKUBAY1 00000021 100447 09688501

01 FC:102	80.00	CH
-----------	-------	----

PTO-1556  
(5/87)

U.S. GPO: 1999-459-022/19144

**PATENT APPLICATION FEE DETERMINATION RECORD**  
Effective October 1, 2001

**CLAIMS AS FILED - PART I**

	(Column 1)	(Column 2)
TOTAL CLAIMS		
FOR	NUMBER FILED	NUMBER EXTRA
TOTAL CHARGEABLE CLAIMS	39 minus 20 = *	*
INDEPENDENT CLAIMS	8 minus 3 = *	*
MULTIPLE DEPENDENT CLAIM PRESENT	<input type="checkbox"/>	

\* If the difference in column 1 is less than zero, enter "0" in column 2

SMALL ENTITY TYPE  OR

OTHER THAN SMALL ENTITY

RATE	FEE
BASIC FEE	370.00
X\$ 9=	
X42=	
+140=	
TOTAL	

RATE	FEE
BASIC FEE	740.00
X\$18=	
X84=	
+280=	
TOTAL	

**CLAIMS AS AMENDED - PART II**

	(Column 1)	(Column 2)	(Column 3)
AMENDMENT A	CLAIMS REMAINING AFTER AMENDMENT	HIGHEST NUMBER PREVIOUSLY PAID FOR	PRESENT EXTRA
	Total	Minus	**
	Independent	Minus	***
FIRST PRESENTATION OF MULTIPLE DEPENDENT CLAIM <input type="checkbox"/>			

SMALL ENTITY OR

OTHER THAN SMALL ENTITY

RATE	ADDITIONAL FEE
X\$ 9=	
X42=	
+140=	
TOTAL ADDIT. FEE	

RATE	ADDITIONAL FEE
X\$18=	
X84=	
+280=	
TOTAL ADDIT. FEE	

(Column 1) (Column 2) (Column 3)

	(Column 1)	(Column 2)	(Column 3)
AMENDMENT B	CLAIMS REMAINING AFTER AMENDMENT	HIGHEST NUMBER PREVIOUSLY PAID FOR	PRESENT EXTRA
	Total	Minus	**
	Independent	Minus	***
FIRST PRESENTATION OF MULTIPLE DEPENDENT CLAIM <input type="checkbox"/>			

RATE	ADDITIONAL FEE
X\$ 9=	
X42=	
+140=	
TOTAL ADDIT. FEE	

RATE	ADDITIONAL FEE
X\$18=	
X84=	
+280=	
TOTAL ADDIT. FEE	

(Column 1) (Column 2) (Column 3)

	(Column 1)	(Column 2)	(Column 3)
AMENDMENT C	CLAIMS REMAINING AFTER AMENDMENT	HIGHEST NUMBER PREVIOUSLY PAID FOR	PRESENT EXTRA
	Total	Minus	**
	Independent	Minus	***
FIRST PRESENTATION OF MULTIPLE DEPENDENT CLAIM <input type="checkbox"/>			

RATE	ADDITIONAL FEE
X\$ 9=	
X42=	
+140=	
TOTAL ADDIT. FEE	

RATE	ADDITIONAL FEE
X\$18=	
X84=	
+280=	
TOTAL ADDIT. FEE	

\* If the entry in column 1 is less than the entry in column 2, write "0" in column 3.  
 \*\* If the "Highest Number Previously Paid For" IN THIS SPACE is less than 20, enter "20."  
 \*\*\* If the "Highest Number Previously Paid For" IN THIS SPACE is less than 3, enter "3."  
 The "Highest Number Previously Paid For" (Total or Independent) is the highest number found in the appropriate box in column 1.

BEST AVAILABLE COPY

BEST AVAILABLE COPY

**PATENT APPLICATION FEE DETERMINATION RECORD**  
Effective October 1, 2000

Application or Docket Number

**CLAIMS AS FILED - PART I**

	(Column 1)	(Column 2)
TOTAL CLAIMS	36	
FOR	NUMBER FILED	NUMBER EXTRA
TOTAL CHARGEABLE CLAIMS	36 minus 20=	* 16
INDEPENDENT CLAIMS	8 minus 3 =	* 5
MULTIPLE DEPENDENT CLAIM PRESENT	N	<input type="checkbox"/>

\* If the difference in column 1 is less than zero, enter "0" in column 2

**SMALL ENTITY TYPE**  OR

**OTHER THAN SMALL ENTITY**

RATE	FEE
BASIC FEE	355.00
X\$ 9=	
X40=	
+135=	
TOTAL	

RATE	FEE
BASIC FEE	710.00
X\$18=	288.00
X80=	400
+270=	
TOTAL	1398

**CLAIMS AS AMENDED - PART II**

	(Column 1)		(Column 2)		(Column 3)
AMENDMENT A		CLAIMS REMAINING AFTER AMENDMENT		HIGHEST NUMBER PREVIOUSLY PAID FOR	PRESENT EXTRA
	Total	* 23	Minus	** 36	= -
	Independent	* 5	Minus	*** 8	= -
	FIRST PRESENTATION OF MULTIPLE DEPENDENT CLAIM <input type="checkbox"/>				

**SMALL ENTITY** OR

**OTHER THAN SMALL ENTITY**

RATE	ADDITIONAL FEE
X\$ 9=	
X40=	
+135=	
TOTAL ADDIT. FEE	

RATE	ADDITIONAL FEE
X\$18=	
X80=	
+270=	
TOTAL ADDIT. FEE	

	(Column 1)		(Column 2)		(Column 3)
AMENDMENT B		CLAIMS REMAINING AFTER AMENDMENT		HIGHEST NUMBER PREVIOUSLY PAID FOR	PRESENT EXTRA
	Total	* 26	Minus	** 36	= -
	Independent	* 5	Minus	*** 8	= -
	FIRST PRESENTATION OF MULTIPLE DEPENDENT CLAIM <input type="checkbox"/>				

RATE	ADDITIONAL FEE
X\$ 9=	
X40=	
+135=	
TOTAL ADDIT. FEE	

RATE	ADDITIONAL FEE
X\$18=	
X80=	
+270=	
TOTAL ADDIT. FEE	

	(Column 1)		(Column 2)		(Column 3)
AMENDMENT C		CLAIMS REMAINING AFTER AMENDMENT		HIGHEST NUMBER PREVIOUSLY PAID FOR	PRESENT EXTRA
	Total		Minus		=
	Independent		Minus		=
	FIRST PRESENTATION OF MULTIPLE DEPENDENT CLAIM <input type="checkbox"/>				

RATE	ADDITIONAL FEE
X\$ 9=	
X40=	
+135=	
TOTAL ADDIT. FEE	

RATE	ADDITIONAL FEE
X\$18=	
X80=	
+270=	
TOTAL ADDIT. FEE	

\* If the entry in column 1 is less than the entry in column 2, write "0" in column 3.  
 \*\* If the "Highest Number Previously Paid For" IN THIS SPACE is less than 20, enter "20."  
 \*\*\* If the "Highest Number Previously Paid For" IN THIS SPACE is less than 3, enter "3."  
 The "Highest Number Previously Paid For" (Total or Independent) is the highest number found in the appropriate box in column 1.

Docket No. 47079-00077

#2

IN THE UNITED STATES PATENT AND TRADEMARK OFFICE



Applicant(s):	Shridhar P. Joshi	)	Group Art Unit: Unknown
		)	
Serial No.:	Unassigned	)	Examiner: Unknown
		)	
Filed:	October 16, 2000	)	

For: Method of Transferring Gaming Data on a Global Computer Network

To the Assistant Commissioner  
for Patents  
Washington, D.C. 20231

CERTIFICATE OF MAILING BY EXPRESS MAIL
"EXPRESS MAIL" Mailing Label No. <b>EL705449427US</b>
Date of Deposit: <b>October 16, 2000</b>
I hereby certify that this paper or fee is being deposited with the U.S. Postal Service "Express Mail Post Office to Addressee" service under 37 CFR 1.10 on the date indicated above and is addressed to the Assistant Commissioner for Patents, Washington, D.C. 20231
Type or Print Name <i>Jaekie Arnold</i>
Signature <i>Jaekie Arnold</i>

Dear Sir:

**INFORMATION DISCLOSURE STATEMENT**

In accordance with Applicant's duty under 37 C.F.R. § 1.56 and 1.97, Applicant hereby submits the attached form PTO-1449 (modified) which lists art cited. The art listed therein, while of some relevance, is not necessarily considered to teach or suggest any aspect of the invention described and claimed in the above-identified patent application. This statement is also not to be construed as a representation that a search has, or has not, been conducted or that no better art exists. Rather, this statement discloses only the best art of which the Applicant is aware.

In considering the art set forth below, it may be noted by the Examiner that certain of the references may contain markings, underlinings or other notations. These markings or notations are not to be construed as drawing the Examiner's attention either to selected parts or away from other parts of the references. Any such markings were either present on the copies of the

references obtained by Applicant, or were made thereon during the study of the references by the Applicant and/or his attorneys.

The Examiner is respectfully requested to consider each of the cited references, indicate such consideration by initialing each reference on the enclosed Form PTO-1449 (modified) and return a copy of the same with the next communication to the Applicant. For the convenience of the Examiner in considering the references, copies of the cited references are enclosed with this communication.

Respectfully submitted,



Matthew O. Brady  
Reg. No. 44,554

Jenkins & Gilchrist, P.C.  
1445 Ross Avenue, Suite 3200  
Dallas, Texas 75202-2799  
312/425-8512 (Direct)  
312/425-3909 (Fax)

RECEIVED  
MAR 25 2002  
OPIE/JCWS



UNITED STATES DEPARTMENT OF COMMERCE  
Patent and Trademark Office  
ASSISTANT SECRETARY AND COMMISSIONER  
OF PATENTS AND TRADEMARKS  
Washington, D.C. 20231

3713  
#  
LI  
en  
3-29-02

CHANGE OF ADDRESS/POWER OF ATTORNEY

FILE LOCATION 37C2 SERIAL NUMBER 09688501 PATENT NUMBER  
THE CORRESPONDENCE ADDRESS HAS BEEN CHANGED TO CUSTOMER # 30223  
THE PRACTITIONERS OF RECORD HAVE BEEN CHANGED TO CUSTOMER # 30223  
THE FEE ADDRESS HAS BEEN CHANGED TO CUSTOMER # 30223  
ON 02/19/02 THE ADDRESS OF RECORD FOR CUSTOMER NUMBER 30223 IS:

JENKENS & GILCHRIST, P.C.  
225 WEST WASHINGTON  
SUITE 2600  
CHICAGO IL 60606

AND THE PRACTITIONERS OF RECORD FOR CUSTOMER NUMBER 30223 ARE:

20087 26044 27187 27786 27957 34713 38206 39618 41774 42568  
42571 44192 47100 48311 48655 48733

RECEIVED  
MAR 27 2002  
TECHNOLOGY CENTER R3700

PTO INSTRUCTIONS: PLEASE TAKE THE FOLLOWING ACTION WHEN THE  
CORRESPONDENCE ADDRESS HAS BEEN CHANGED TO CUSTOMER NUMBER:  
RECORD, ON THE NEXT AVAILABLE CONTENTS LINE OF THE FILE JACKET,  
'ADDRESS CHANGE TO CUSTOMER NUMBER'. LINE THROUGH THE OLD  
ADDRESS ON THE FILE JACKET LABEL AND ENTER ONLY THE 'CUSTOMER  
NUMBER' AS THE NEW ADDRESS. FILE THIS LETTER IN THE FILE JACKET.  
WHEN ABOVE CHANGES ARE ONLY TO FEE ADDRESS AND/OR PRACTITIONERS  
OF RECORD, FILE LETTER IN THE FILE JACKET.  
THIS FILE IS ASSIGNED TO GAU 3713.



UNITED STATES PATENT AND TRADEMARK OFFICE

UNITED STATES DEPARTMENT OF COMMERCE  
United States Patent and Trademark Office  
Address: COMMISSIONER OF PATENTS AND TRADEMARKS  
Washington, D.C. 20231  
www.uspto.gov

APPLICATION NO.	FILING DATE	FIRST NAMED INVENTOR	ATTORNEY DOCKET NO.	CONFIRMATION NO.
09/688,501	10/16/2000	Shridhar P. Joshi	47079-00077	3225

30223 7590 08/30/2002

JENKENS & GILCHRIST, P.C.  
225 WEST WASHINGTON  
SUITE 2600  
CHICAGO, IL 60606

EXAMINER

RADA, ALEX P

ART UNIT PAPER NUMBER

3713

DATE MAILED: 08/30/2002

Please find below and/or attached an Office communication concerning this application or proceeding.



<b>Office Action Summary</b>	Application No. 09/688,501	Applicant(s) JOSHI, SHRIDHAR P.	
	Examiner Alex P. Rada	Art Unit 3713	

-- The MAILING DATE of this communication appears on the cover sheet with the correspondence address --

**Period for Reply**

A SHORTENED STATUTORY PERIOD FOR REPLY IS SET TO EXPIRE 1 MONTH(S) FROM THE MAILING DATE OF THIS COMMUNICATION.

- Extensions of time may be available under the provisions of 37 CFR 1.136(a). In no event, however, may a reply be timely filed after SIX (6) MONTHS from the mailing date of this communication.
- If the period for reply specified above is less than thirty (30) days, a reply within the statutory minimum of thirty (30) days will be considered timely.
- If NO period for reply is specified above, the maximum statutory period will apply and will expire SIX (6) MONTHS from the mailing date of this communication.
- Failure to reply within the set or extended period for reply will, by statute, cause the application to become ABANDONED (35 U.S.C. § 133).
- Any reply received by the Office later than three months after the mailing date of this communication, even if timely filed, may reduce any earned patent term adjustment. See 37 CFR 1.704(b).

**Status**

- 1)  Responsive to communication(s) filed on 25 March 2002.
- 2a)  This action is **FINAL**.
- 2b)  This action is non-final.
- 3)  Since this application is in condition for allowance except for formal matters, prosecution as to the merits is closed in accordance with the practice under *Ex parte Quayle*, 1935 C.D. 11, 453 O.G. 213.

**Disposition of Claims**

- 4)  Claim(s) \_\_\_\_\_ is/are pending in the application.
- 4a) Of the above claim(s) \_\_\_\_\_ is/are withdrawn from consideration.
- 5)  Claim(s) \_\_\_\_\_ is/are allowed.
- 6)  Claim(s) \_\_\_\_\_ is/are rejected.
- 7)  Claim(s) \_\_\_\_\_ is/are objected to.
- 8)  Claim(s) 1-36 are subject to restriction and/or election requirement.

**Application Papers**

- 9)  The specification is objected to by the Examiner.
- 10)  The drawing(s) filed on \_\_\_\_\_ is/are: a)  accepted or b)  objected to by the Examiner.  
Applicant may not request that any objection to the drawing(s) be held in abeyance. See 37 CFR 1.85(a).
- 11)  The proposed drawing correction filed on \_\_\_\_\_ is: a)  approved b)  disapproved by the Examiner.  
If approved, corrected drawings are required in reply to this Office action.
- 12)  The oath or declaration is objected to by the Examiner.

**Priority under 35 U.S.C. §§ 119 and 120**

- 13)  Acknowledgment is made of a claim for foreign priority under 35 U.S.C. § 119(a)-(d) or (f).  
a)  All b)  Some \* c)  None of:  
1.  Certified copies of the priority documents have been received.  
2.  Certified copies of the priority documents have been received in Application No. \_\_\_\_\_.  
3.  Copies of the certified copies of the priority documents have been received in this National Stage application from the International Bureau (PCT Rule 17.2(a)).  
\* See the attached detailed Office action for a list of the certified copies not received.
- 14)  Acknowledgment is made of a claim for domestic priority under 35 U.S.C. § 119(e) (to a provisional application).  
a)  The translation of the foreign language provisional application has been received.
- 15)  Acknowledgment is made of a claim for domestic priority under 35 U.S.C. §§ 120 and/or 121.

**Attachment(s)**

- 1)  Notice of References Cited (PTO-892)
- 2)  Notice of Draftsperson's Patent Drawing Review (PTO-948)
- 3)  Information Disclosure Statement(s) (PTO-1449) Paper No(s) \_\_\_\_\_.
- 4)  Interview Summary (PTO-413) Paper No(s). \_\_\_\_\_.
- 5)  Notice of Informal Patent Application (PTO-152)
- 6)  Other:

## DETAILED ACTION

### *Election/Restrictions*

1. Restriction to one of the following inventions is required under 35 U.S.C. 121:
  - I. Claims 1-10, 21, 35, and 36 drawn to transferring game data to a remote terminal, classified in class 463, subclass 43.
  - II. Claims 11-20, drawn to a remote computer structure, classified in class 463, subclass 42.
  - III. Claims 22-25, drawn to a method for transferring gaming data on a global computer network, classified in class 463, subclass 29.
  - IV. Claims 26-31, drawn to a method of receiving transferred data via a global computer network, classified in class 709, subclass 200.
  - V. Claims 32-34, drawn to a web page, classified in class 705, subclass 1.

The inventions are distinct, each from the other because of the following reasons:

2. Inventions I and II are related as subcombinations disclosed as usable together in a single combination. The subcombinations are distinct from each other if they are shown to be separately usable. In the instant case, invention II has separate utility such as personal computer for playing games solely on the personal computer. See MPEP § 806.05(d).
3. Inventions III and IV are related as combination and subcombination. Inventions in this relationship are distinct if it can be shown that (1) the combination as claimed does not require the particulars of the subcombination as claimed for patentability, and (2) that the subcombination has utility by itself or in other combinations (MPEP § 806.05(c)). In the instant case, the combination as claimed does not require the particulars of the subcombination as

claimed because invention IV does not need the global network to access files. The subcombination has separate utility such as a game player playing against another game player on a peer-to-peer connection.

4. Inventions I and V are related as subcombinations disclosed as usable together in a single combination. The subcombinations are distinct from each other if they are shown to be separately usable. In the instant case, invention V has separate utility such as accessing different information not related to games. See MPEP § 806.05(d).

5. Because these inventions are distinct for the reasons given above and have acquired a separate status in the art as shown by their different classification, restriction for examination purposes as indicated is proper.

6. Because these inventions are distinct for the reasons given above and have acquired a separate status in the art because of their recognized divergent subject matter, restriction for examination purposes as indicated is proper.

#### *Conclusion*

Any inquiry concerning this communication or earlier communications from the examiner should be directed to Alex P. Rada whose telephone number is 703-308-7135. The examiner can normally be reached on Monday - Friday, 08:00-16:00.

Alex P. Rada  
Examiner  
Art Unit 3713

APR  
apr  
August 28, 2002

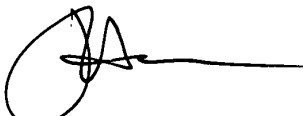
  
JESSICA HARRISON  
PRIMARY EXAMINER



Customer No. 30223

R Kent  
10/11/02  
#5/a  
PATENT  
Election

**IN THE UNITED STATES PATENT AND TRADEMARK OFFICE**

In Re Application Of: )  
)  
Shridhar P. Joshi )  
)  
Application No.: 09/688,501 )  
)  
Filed: October 16, 2000 )  
)  
For: Method Of Transferring Gaming )  
Data On A Global Computer )  
Network )

Atty. Docket No.: 47079-00077  
Examiner: Alex P. Rada  
Group Art Unit: 3713

**RECEIVED**  
OCT - 9 2002  
TECHNOLOGY CENTER R3700

**CERTIFICATE OF MAILING**  
I hereby certify that this correspondence is being deposited with the United States Postal Service as first class mail, postage prepaid, in an envelope addressed to the Commissioner for Patents, Attn: Box Non-Fee Amendment, Washington, D.C. 20231, on September 30, 2002.  
Signature: *Janet L. Newmaker*  
Janet L. Newmaker

**RESPONSE TO RESTRICTION/ELECTION REQUIREMENT**

Commissioner for Patents  
Washington, D.C. 20231

Attn: Box Non-Fee Amendment

Dear Sir:

This is in response to the Office Action dated August 30, 2002. The shortened statutory period for response is one month from the mailing date, i.e., by September 30, 2002, and this response is being submitted within that time period. Please enter the following claim amendments and remarks into the record for this application.

**IN THE CLAIMS:**

Please cancel claims 22-34.

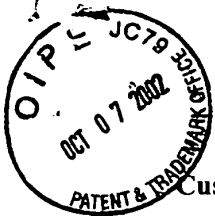

Customer No. 30223

PATENT

IN THE UNITED STATES PATENT AND TRADEMARK OFFICE

In Re Application Of: )  
Shridhar P. Joshi )  
Application No.: 09/688,501 )  
Filed: October 16, 2000 )  
For: Method Of Transferring Gaming )  
Data On A Global Computer )  
Network )

Atty. Docket No.: 47079-00077  
Examiner: Alex P. Rada  
Group Art Unit: 3713

RECEIVED  
OCT - 9 2002

TECHNOLOGY CENTER R3700

CERTIFICATE OF MAILING  
I hereby certify that this correspondence is being deposited with the United States Postal Service as first class mail, postage prepaid, in an envelope addressed to the Commissioner for Patents, Attn: Box Non-Fee Amendment, Washington, D.C. 20231, on September 30, 2002.  
Signature: *Janet L. Newmaker*  
Janet L. Newmaker

AMENDMENT TRANSMITTAL

Commissioner for Patents  
Washington, D.C. 20231

Attn: Box Non-Fee Amendment

Dear Sir:

Transmitted herewith is a "Response To Restriction/Election Requirement" for this application.

The Applicant is other than a small entity.

The proceedings herein are for a patent application, and the provisions of 37 C.F.R. § 1.136 apply.

The Applicant believes that no extension of time is required. This conditional petition is being made, however, to provide for the possibility that the Applicant has inadvertently overlooked the need for a petition for extension of time.

The fee for claims (37 C.F.R. § 1.16(b)-(d)) has been calculated as shown below.

	Claims Remaining	Highest No. Paid For	Extra	Small Entity	Large Entity
Total	22	36	0 x	\$ 9 = \$	\$ 18 = \$ 0
Independent	4	8	0 x	\$ 42 = \$	\$ 84 = \$ 0
Multiple Dependent Claim Presented				\$ 140 = \$	\$ 280 = \$ 0
<b>TOTAL ADDITIONAL FEE</b>					\$ 0

There is no additional fee for claims.

The Commissioner is hereby authorized to charge any additional fees which may be required, or credit any overpayment, to Deposit Account No. 10-0447 (47079-00077). A duplicate copy of this Transmittal is enclosed for that purpose.

Respectfully submitted,



Daniel J. Burnham  
Reg. No. 39,618  
Jenkins & Gilchrist  
225 West Washington Street, Suite 2600  
Chicago, IL 60606-3418  
(312) 425-3900  
Attorney for Applicant

Date: September 30, 2002

## REMARKS

Claims 1-21, 35 and 36 remain in the application for prosecution. Claims 22-34 have been cancelled. Submitted herewith is a clean set of pending claims. The Applicant confirms that the inventorship for the remaining claims has not changed.

The Applicant provisionally elects the invention of Group I, which includes claims 1-10, 21, 35 and 36. The Applicant makes this election, however, with traverse. It is the Applicant's belief that the claims of Group I should be grouped with the claims of Group II as the two are directed to closely related subject matter. As noted in MPEP § 806.05, related inventions "may be" subject to a restriction requirement, and the Applicant respectfully requests the Examiner to combine the claims of Group I and Group II.

In essence, the claims of Group II are directed to an apparatus that performs the process of method claim 1 within Group I. The Applicant notes that had he simply changed the term "computer" in claim 11 to "terminal," then claim 1 of Group I and claim 11 of Group II would have been nearly identical. Further, apparatus claim 11 is nearly identical to apparatus claim 21 in Group I. The functions to be performed by the microprocessor in claim 11 are nearly identical to the steps of claim 1 or the elements of claim 21.

The claims in these two groups seem to be so closely related that the burden on the Examiner of combining these two groups is minimal, compared to the burden on the Applicant for paying for and maintaining two patents on subject matter that is so closely related. The Applicant recognizes that the Examiner is given much deference in these situations when rendering a restriction requirement. The Applicant has cancelled claims in Groups III, IV and V and these claims may be pursued in continuing applications. The Applicant, however, respectfully requests that the Examiner combine Groups I and II.

**Conclusion**

The Applicant believes the claims are allowable over the prior art of record and are in condition for allowance.

If there are any matters which may be resolved or clarified through a telephone interview, the Examiner is respectfully requested to contact the Applicant's undersigned attorney at the number indicated.

Respectfully submitted,

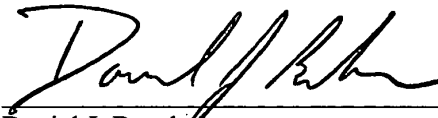

Date: September 30, 2002

---

Daniel J. Burnham  
Reg. No. 39,618  
Jenkins & Gilchrist  
225 West Washington Street, Suite 2600  
Chicago, IL 60606-3418  
(312) 425-3900  
Attorney for Applicant





**Clean Set Of Pending Claims**  
**U.S. Patent Application No. 09/688,501**

**RECEIVED**  
OCT - 9 2002  
TECHNOLOGY CENTER R3700

1. A method for transferring gaming data to a remote terminal located outside a gaming establishment comprising:  
receiving at said remote terminal information from a gaming site on a global computer network identifying a plurality of gaming machines at said gaming establishment;  
transmitting data from said remote terminal selecting at least one of said gaming machines for remote information transfer;  
receiving at said remote terminal a text or graphical outcome resulting from a play of said at least one of said gaming machines; and  
generating a payout if said outcome meets predetermined criteria.
2. The method of Claim 1, wherein said selected gaming machine comprising a slot machine and wherein said outcome includes a reel position.
3. The method of Claim 1, wherein said step of receiving information includes receiving information selecting at least two of said plurality of gaming machines for remote play.
4. The method of claim 3 wherein said step of receiving information includes receiving a gaming machine identifier.
5. The method of claim 3 wherein said step of receiving information includes receiving a gaming machine type.
6. The method of claim 3 wherein said step of receiving information includes receiving player preferences.
7. The method of claim 1 wherein said selected gaming machine comprises a video poker machine including a display for displaying a poker hand.

8. The method of claim 1 wherein said outcome comprises information identifying the value of said payout; and

further comprising the step of using said payout information to simulate a display of said outcome at said remote location.

9. The method of claim 1 wherein said selected gaming machine comprises a slot machine and wherein said outcome comprises information identifying a reel position of said gaming machine; and

further comprising the step of using said outcome information to display said reel position at said remote location.

10. The method of claim 1 and further including the steps of receiving a player identifier; and transmitting said player identifier for identification of said player.

11. A remote computer for the remote play of a local gaming machine located within a gaming establishment, the remote computer being located outside said gaming establishment, said remote computer comprising:

a microprocessor;

memory connected to said microprocessor and including instructions for controlling said microprocessor; and

said microprocessor being operative with said instructions in said memory to:

receive information identifying a plurality of local gaming machines located within said gaming establishment,

transmit data selecting at least one of said plurality of local gaming machines for remote play,

receive a text or graphical outcome resulting from a local play of said selected gaming machines, and

generate a payout if said outcome meets predetermined criteria.

12. The remote computer of claim 11 wherein said selected gaming machine comprises a slot machine and wherein said outcome includes a reel position.

13. The remote computer of claim 11 wherein said operation of receiving information includes receiving information selecting at least two of said plurality of gaming machines for remote play.

14. The remote computer of claim 11 wherein said operation of receiving information includes receiving a gaming machine identifier.

15. The remote computer of claim 14 wherein said operation of receiving information includes receiving a gaming machine type.

16. The remote computer of claim 14 wherein said operation of receiving information includes receiving player preferences.

17. The remote computer of claim 11 wherein said selected gaming machine comprises a video poker machine including a display for displaying a poker hand.

18. The remote computer of claim 11 wherein said outcome comprises data identifying the value of said payout; and  
further comprising the operation of using said payout data to simulate a display of said outcome at said remote location.

19. The remote computer of claim 11 wherein said outcome comprises information identifying a reel position of said selected gaming machine; and  
further comprising the operation of using said outcome data to display said reel position at said remote location.

20. The remote computer of claims 11 further including the operations of: receiving a player identifier; and

transmitting said player identifier for identification of said player.

21. A remote computer located outside a gaming establishment, said remote computer comprising:

means for receiving information identifying a plurality of local gaming machines each engaged in play within said gaming establishment;

means for transmitting data from selecting at least a one of said plurality of local gaming machines for information transfer;

means for receiving a text or graphical outcome resulting from a play of said selected local gaming machines; and

means for generating a payout if said outcome meets predetermined criteria.

35. A remote gaming method comprising:

accessing, via a remote terminal, a gaming site on a global computer network connected to said remote terminal;

providing, via said remote terminal, personal identification information to said gaming site;

selecting, via said remote terminal, a game of chance located at a gaming establishment for remote play, said remote terminal being located outside said gaming establishment;

placing, via said remote terminal, a wager for playing said selected game; and

receiving randomly-generated text or graphical outcome data at said remote terminal for said selected game, said outcome data being generated by one of a gaming server and a gaming machine at said gaming establishment and relayed to said gaming site.

36. A remote gaming method using a gaming server, a remote terminal, and a gaming site on a global computer network, said gaming server being located at a gaming establishment, said remote terminal being located outside said gaming establishment, said gaming site being provided on said global computer network, the method comprising:

receiving, at said gaming server, personal identification information, game selection information, and wager information from a player accessing said gaming site via said remote terminal, said remote terminal being connected to said global computer network;

randomly generating outcome data at one of said gaming server and a gaming machine communicatively coupled to said gaming server, said outcome data being generated for a game selected according to said game selection information, said gaming machine being located at said gaming establishment;

receiving said outcome data at said gaming server; and

transmitting said outcome data from said gaming server to said gaming site for display to said player on said remote terminal in text or graphical form.



UNITED STATES PATENT AND TRADEMARK OFFICE

3  
UNITED STATES DEPARTMENT OF COMMERCE  
United States Patent and Trademark Office  
Address: COMMISSIONER OF PATENTS AND TRADEMARKS  
Washington, D.C. 20231  
www.uspto.gov

APPLICATION NO.	FILING DATE	FIRST NAMED INVENTOR	ATTORNEY DOCKET NO.	CONFIRMATION NO.
09/688,501	10/16/2000	Shridhar P. Joshi	47079-00077	3225

30223            7590            12/17/2002  
JENKENS & GILCHRIST, P.C.  
225 WEST WASHINGTON  
SUITE 2600  
CHICAGO, IL 60606

EXAMINER

RADA, ALEX P

ART UNIT            PAPER NUMBER

3714

DATE MAILED: 12/17/2002

Please find below and/or attached an Office communication concerning this application or proceeding.

KC

<b>Office Action Summary</b>	Application No. 09/688,501	Applicant(s) JOSHI, SHRIDHAR P.	
	Examiner Alex P. Rada	Art Unit 3714	

**-- The MAILING DATE of this communication appears on the cover sheet with the correspondence address --**  
**Period for Reply**

A SHORTENED STATUTORY PERIOD FOR REPLY IS SET TO EXPIRE 3 MONTH(S) FROM THE MAILING DATE OF THIS COMMUNICATION.

- Extensions of time may be available under the provisions of 37 CFR 1.136(a). In no event, however, may a reply be timely filed after SIX (6) MONTHS from the mailing date of this communication.
- If the period for reply specified above is less than thirty (30) days, a reply within the statutory minimum of thirty (30) days will be considered timely.
- If NO period for reply is specified above, the maximum statutory period will apply and will expire SIX (6) MONTHS from the mailing date of this communication.
- Failure to reply within the set or extended period for reply will, by statute, cause the application to become ABANDONED (35 U.S.C. § 133).
- Any reply received by the Office later than three months after the mailing date of this communication, even if timely filed, may reduce any earned patent term adjustment. See 37 CFR 1.704(b).

**Status**

- 1)  Responsive to communication(s) filed on 07 October 2002.
- 2a)  This action is **FINAL**.
- 2b)  This action is non-final.
- 3)  Since this application is in condition for allowance except for formal matters, prosecution as to the merits is closed in accordance with the practice under *Ex parte Quayle*, 1935 C.D. 11, 453 O.G. 213.

**Disposition of Claims**

- 4)  Claim(s) 1-21, 35 and 36 is/are pending in the application.
  - 4a) Of the above claim(s) \_\_\_\_\_ is/are withdrawn from consideration.
- 5)  Claim(s) \_\_\_\_\_ is/are allowed.
- 6)  Claim(s) 1-21, 35 and 36 is/are rejected.
- 7)  Claim(s) \_\_\_\_\_ is/are objected to.
- 8)  Claim(s) \_\_\_\_\_ are subject to restriction and/or election requirement.

**Application Papers**

- 9)  The specification is objected to by the Examiner.
- 10)  The drawing(s) filed on \_\_\_\_\_ is/are: a)  accepted or b)  objected to by the Examiner.  
 Applicant may not request that any objection to the drawing(s) be held in abeyance. See 37 CFR 1.85(a).
- 11)  The proposed drawing correction filed on \_\_\_\_\_ is: a)  approved b)  disapproved by the Examiner.  
 If approved, corrected drawings are required in reply to this Office action.
- 12)  The oath or declaration is objected to by the Examiner.

**Priority under 35 U.S.C. §§ 119 and 120**

- 13)  Acknowledgment is made of a claim for foreign priority under 35 U.S.C. § 119(a)-(d) or (f).
  - a)  All b)  Some \* c)  None of:
    - 1.  Certified copies of the priority documents have been received.
    - 2.  Certified copies of the priority documents have been received in Application No. \_\_\_\_\_.
    - 3.  Copies of the certified copies of the priority documents have been received in this National Stage application from the International Bureau (PCT Rule 17.2(a)).
  - \* See the attached detailed Office action for a list of the certified copies not received.
- 14)  Acknowledgment is made of a claim for domestic priority under 35 U.S.C. § 119(e) (to a provisional application).
  - a)  The translation of the foreign language provisional application has been received.
- 15)  Acknowledgment is made of a claim for domestic priority under 35 U.S.C. §§ 120 and/or 121.

**Attachment(s)**

- 1)  Notice of References Cited (PTO-892)
- 2)  Notice of Draftsperson's Patent Drawing Review (PTO-948)
- 3)  Information Disclosure Statement(s) (PTO-1449) Paper No(s) 2.
- 4)  Interview Summary (PTO-413) Paper No(s). \_\_\_\_\_
- 5)  Notice of Informal Patent Application (PTO-152)
- 6)  Other:

## DETAILED ACTION

### *Election/Restrictions*

1. Applicant's election with traverse of Group I, which includes claims 1-10, 21, 35, and 36 in Paper No. 4 is acknowledged. The traversal is on the ground(s) that Group I should be grouped with the claims of Group II as the two are directed to closely related subject matter. The claims of Group II are directed to an apparatus that performs the process of method claim 1 within Group I. The applicant notes that the simple change of the term "computer" in claim 11 to "terminal," then claims 1 of Group I and claim 11 of Group II would have been nearly identical and the apparatus of claim 11 is nearly identical to apparatus claim 21 in Group I, in which the functions to be performed by the microprocessor in claim 11 are nearly identical to the steps of claim 1 or the elements of claim 21. This is found to be persuasive and therefore Groups I and II have been joined. The original requirement between the other groups is still deemed proper and is therefore made FINAL.

### *Specification*

2. The disclosure is objected to because of the following informalities: the Brief Description of the Several Views of the Drawing(s) is missing in the specification. See MPEP § 608.01(f). Appropriate correction is required.
3. The disclosure is objected to because it contains an embedded hyperlink and/or other form of browser-executable code. Applicant is required to delete the embedded hyperlink and/or other form of browser-executable code. See MPEP § 608.01.



*Claim Rejections - 35 USC § 102*

4. The following is a quotation of the appropriate paragraphs of 35 U.S.C. 102 that form the basis for the rejections under this section made in this Office action:

A person shall be entitled to a patent unless –

(e) the invention was described in (1) an application for patent, published under section 122(b), by another filed in the United States before the invention by the applicant for patent or (2) a patent granted on an application for patent by another filed in the United States before the invention by the applicant for patent, except that an international application filed under the treaty defined in section 351(a) shall have the effects for purposes of this subsection of an application filed in the United States only if the international application designated the United States and was published under Article 21(2) of such treaty in the English language.

5. Claims 1-21, 35, and 36 are rejected under 35 U.S.C. 102(e) as being anticipated by Walker `437.

6. Walker discloses: a means for receiving information identifying a plurality of local gaming machines, a means for transmitting data from a game machine, a means for receiving a text or graphical outcome, a microprocessor, a memory connected to the microprocessor, transmitting text and graphical outcome and a means for generating a payout as recited in claims 1, 11, 21, 35, and 36; the gaming machine comprising a slot machine and the outcome includes a reel position as recited in claims 2 and 12; the receiving information includes receiving information selecting at least two of the gaming machine for remote play as recited in claims 3 and 13; the receiving information includes receiving a game machine identifier, machine type, and player preferences as recited in claims 4-6 and 14-16; the game machine comprising a video poker machine as recited in claims 7 and 17; the outcome comprising information identifying the value of the payout and using the payout information to simulate a display do the outcome at the remote location as recited in claims 8 and 18; the slot machine comprises information identifying a reel position of the gaming machine and the outcome information to display the reel position at

the remote location as recited in claims 9 and 19; and the transmitting the player identifier for identification of the player as recited in claims 10 and 20.

### *Conclusion*

7. The prior art made of record and not relied upon is considered pertinent to applicant's disclosure.

Lvov `011 discloses an electronic gaming system that includes a central computer station, a plurality of peripheral computer station, and a data exchange network.

Saffari `561 discloses a mechanism to enable use of a disabled game resident on multiple platform gamin machines.

Wiltshire `602 discloses a compute gaming system and method of operation thereof are provided the both drastically reduce the cost of gaming station and allow contemporaneous access to multiple game program from a single station.

Vuong `552 discloses a networked based gaming system that enable a plurality of players to place wagers on a real-time game of chance being conducted in a casino via a distributed network system.

Walker `983 discloses a method and device for automated repetitive play of a gaming device.

Baba `371 discloses improper registration of the data of participating teams is prevented in an online-participation game system.

Franchi `533 discloses a casino operation system for controlling the flow of the funds and monitoring gambling activities in a casino or a gaming establishment.

Muta '003 discloses a control of a GUI screen at a server in a remote location obtained without requiring the prior installment of special remote controlling software in a remote controlling machine.

Any inquiry concerning this communication or earlier communications from the examiner should be directed to Alex P. Rada whose telephone number is 703-308-7135. The examiner can normally be reached on Monday - Friday, 08:00-16:00.

If attempts to reach the examiner by telephone are unsuccessful, the examiner's supervisor, Tom Hughes can be reached on 703-308-1806. The fax phone numbers for the organization where this application or proceeding is assigned are 703-872-9302 for regular communications and 703-872-9303 for After Final communications.

Any inquiry of a general nature or relating to the status of this application or proceeding should be directed to the receptionist whose telephone number is 703-308-1148.

<sup>102</sup>  
apr  
December 11, 2002

  
S. THOMAS HUGHES  
SUPERVISORY PATENT EXAMINER  
TECHNOLOGY CENTER 3700

<b>Notice of References Cited</b>	Application/Control No. 09/688,501	Applicant(s)/Patent Under Reexamination JOSHI, SHRIDHAR P.	
	Examiner Alex P. Rada	Art Unit 3714	Page 1 of 1

**U.S. PATENT DOCUMENTS**

*	Document Number Country Code-Number-Kind Code	Date MM-YYYY	Name	Classification	
	A	US-6,361,437	03-2002	Walker et al.	463/23
	B	US-6,117,011	09-2000	Lvov, Denis Ernestovich	463/25
	C	US-6,264,561	07-2001	Saffari et al.	463/42
	D	US-6,409,602	06-2002	Wiltshire et al.	463/42
	E	US-5,762,552	06-1998	Vuong et al.	463/25
	F	US-6,012,983	01-2000	Walker et al.	463/20
	G	US-6,406,371	06-2002	Baba et al.	463/42
	H	US-5,770,533	06-1998	Franchi, John Franco	463/42
	I	US-6,286,003	09-2001	Muta, Hidemasa	707/10
	J	US-			
	K	US-			
	L	US-			
	M	US-			

**FOREIGN PATENT DOCUMENTS**

*	Document Number Country Code-Number-Kind Code	Date MM-YYYY	Country	Name	Classification
	N				
	O				
	P				
	Q				
	R				
	S				
	T				

**NON-PATENT DOCUMENTS**

*	Include as applicable: Author, Title Date, Publisher, Edition or Volume, Pertinent Pages)
	U
	V
	W
	X

\*A copy of this reference is not being furnished with this Office action. (See MPEP § 707.05(a).)  
Dates in MM-YYYY format are publication dates. Classifications may be US or foreign.

#2

<p><b>Form PTO-1449 Modified</b></p> <p><b>List of Patents and Publications Cited by Applicant (Use several sheets if necessary)</b></p> <p><b>U.S. Patent Department of Commerce Patent and Trademark Office</b></p>	<p><b>Docket No.:</b> 47079-00077</p>	<p><b>Serial No.:</b> 09/688501 Unassigned</p>
	<p><b>Applicants:</b> Shridhar P. Joshi</p>	
	<p><b>Filing Date:</b> October 16, 2000</p>	<p><b>Group:</b> Unknown 375</p>

09/688501  
 PTO  
 09/688501  
 10/16/00

**U.S. PATENT DOCUMENTS**

Examiner Initial		Document No.	Date	Name	Class	Subclasses
APR	A-1	4,856,787	08/15/1989	Itkis	—	/
APR	A-2	5,586,937	12/24/1996	Menashe	—	/
APR	A-3	5,823,879	10/20/1998	Goldberg et al	—	/
APR	A-4	6,001,016	12/14/1999	Walker et al	—	/
APR	A-5	6,012,984	01/11/2000	Roseman	—	/
APR	A-6	6,104,815	08/15/2000	Alcorn et al	—	/

**FOREIGN PATENT DOCUMENTS**

Examiner Initial		Document No.	Date	Country	Translation	
					Yes	No
	B-1					

**OTHER DOCUMENTS**

Examiner Initials		Author, Title, Date, Pertinent Pages, Etc.
	C-1	

<b>Date Examined:</b>	<b>Examiner:</b> 12-9-02
-----------------------	--------------------------



Customer No. 30223

Handwritten notes and stamps: 7/18, 3/16/03, RECEIVED, MAR 19 2003, TECHNOLOGY CENTER RA700, PATENT

IN THE UNITED STATES PATENT AND TRADEMARK OFFICE

In Re Application Of:	)	Atty. Docket No.: 47079-00077
	)	
Shridhar P. Joshi	)	Examiner: Alex P. Rada
	)	
Application No.: 09/688,501	)	Group Art Unit: 3714
	)	
Filed: October 16, 2000	)	
	)	
For: Method Of Transferring	)	
Gaming Data On A	)	
Global Computer Network	)	

**CERTIFICATE OF MAILING**

I hereby certify that this correspondence is being deposited with the United States Postal Service as first class mail, postage prepaid, in an envelope addressed to the Commissioner for Patents, Attn: Box Non-Fee Amendment, Washington, D.C. 20231, on March 10, 2003.

Signature: Janet L. Newmaker  
Janet L. Newmaker

**REPLY TO OFFICE ACTION**

Commissioner for Patents  
Washington, D.C. 20231

Attn: Box Non-Fee Amendment

Dear Sir:

This is in response to the Office Action dated December 17, 2002. The shortened statutory period for response is three months from the mailing date, i.e., by March 17, 2003, and this response is being submitted within that time period. Please enter the following claim amendments and remarks into the record for this application.

3714



Customer No. 30223

PATENT

IN THE UNITED STATES PATENT AND TRADEMARK OFFICE

In Re Application Of:	)	Atty. Docket No.: 47079-00077
	)	
Shridhar P. Joshi	)	Examiner: Alex P. Rada
	)	
Application No.: 09/688,501	)	Group Art Unit: 3714
	)	
Filed: October 16, 2000	)	
	)	
For: Method Of Transferring	)	
Gaming Data On A	)	
Global Computer Network	)	

**CERTIFICATE OF MAILING**

I hereby certify that this correspondence is being deposited with the United States Postal Service as first class mail, postage prepaid, in an envelope addressed to the Commissioner for Patents, Attn: Box Non-Fee Amendment, Washington, D.C. 20231, on March 10, 2003.

Signature: Janet L. Newmaker  
Janet L. Newmaker

AMENDMENT TRANSMITTAL

Commissioner for Patents  
Washington, D.C. 20231

Attn: Box Non-Fee Amendment

Dear Sir:

Transmitted herewith is a "Reply To Office Action" for this application.

The Applicant is other than a small entity.

The proceedings herein are for a patent application, and the provisions of 37 C.F.R. § 1.136 apply.

The Applicant believes that no extension of time is required. This conditional petition is being made, however, to provide for the possibility that the Applicant has inadvertently overlooked the need for a petition for extension of time.

RECEIVED  
MAR 19 2003  
TECHNOLOGY CENTER R3700

The fee for claims (37 C.F.R. § 1.16(b)-(d)) has been calculated as shown below.

	Claims Remaining	Highest No. Paid For	Extra	Small Entity	Large Entity
Total	26	36	0 x	\$ 9 = \$	\$ 18 = \$ 0
Independent	5	8	0 x	\$ 42 = \$	\$ 84 = \$ 0
Multiple Dependent Claim Presented				\$ 140 = \$	\$ 280 = \$ 0
<b>TOTAL ADDITIONAL FEE</b>					\$ 0

There is no additional fee for claims.

The Commissioner is hereby authorized to charge any additional fees which may be required, or credit any overpayment, to Deposit Account No. 10-0447 (47079-00077). A duplicate copy of this Transmittal is enclosed for that purpose.

Respectfully submitted,

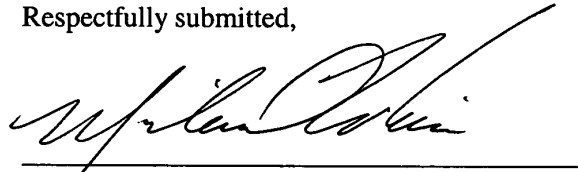

Date: March 5, 2003

Michael L. White  
Reg. No. 39,421  
(773) 961-1267  
Attorney for Applicant



## AMENDMENTS TO THE SPECIFICATION

Page 3, line 15, add the following heading and paragraphs.

---

### BRIEF DESCRIPTION OF THE DRAWINGS

FIG. 1 is a block schematic diagram of a global computing network connecting a personal computer through a web site to a game server.

FIG. 2a and 2b is a flow chart describing the process by which a player uses a remote terminal to wager on a gaming establishment's gaming machine.

---

Page 5, line 22, through page 6, line 16, amend the paragraphs as follows.

Transmission Control Protocol/Internet Protocol ("TCP/IP") controls transmission of data on the Internet to provide World Wide Web communication to users. To insure that data is sent to and received by the appropriate receiver on the Internet, every device communicating on the Internet is assigned a unique address called an Internet Protocol ("IP") address. Elements of the IP address identify the location in the network that a device is connected. Other parts of the IP address identify the specific device. The IP address number has a three-digit element that identifies the state of the resident and an additional seven digits, three of which identify the local exchange of the resident and four digits that specifically identify the home of the resident. The IP address is presently a thirty-two bit binary address, readily processed by computers, but cumbersome for use by human users. Consequently, the majority of IP addresses are assigned mnemonics to make them more "user friendly." The mnemonic consists of two parts: a host name and a domain name. It is this representation of the IP address that is commonly used by Internet users to access Web sites. Conventionally within the World Wide Web, the mnemonic "WWW" is used to represent the host name. The remaining portion of the mnemonic represents

the domain or network where the host resides. ~~For example, www.uspto.gov, identifies a host named "www" in the domain (network) "uspto.gov".~~

B.2  
The standard protocol used by Internet components to address each other and usually is used as a Uniform Resource Locator ("URL"). This terminology appears as the opening element in the web site address. For example, the term "http" in <http://www.uspto.gov>, the Uniform Resource Locator indicates that the request is for "http" formatted data, (i.e., a web page as opposed to, for example, an electronic mail message). The home page for the data resides on the "www" HTTP server on the ~~"uspto.gov" LAN (or domain). The name of the file (to be found most likely in the file server supported by the uspto.gov LAN) is "homepage.html."~~

---

## AMENDMENTS TO THE CLAIMS

Please cancel claims 1-21, 35 and 36. Please add new claims 37-62 as follows.

1-21. (Cancelled)

22-34. (Withdrawn)

35-36. (Cancelled)

---

37. (New) A remote gaming method comprising:

accessing, via a remote terminal, a gaming site on a global computer network connected to said remote terminal;

providing, via said remote terminal, personal identification information to said gaming site;

selecting, via said remote terminal, a game of chance on a gaming machine located at a gaming establishment for remote play, said remote terminal being located outside said gaming establishment;

placing, via said remote terminal, a wager for playing said selected game; and

receiving randomly-generated text or graphical outcome data at said remote terminal for said selected game, said outcome data being generated by one of a gaming server and a gaming machine at said gaming establishment and relayed to said gaming site.

38. (New) A remote gaming method using a gaming server, a remote terminal, and a gaming site on a global computer network, said gaming server being located at a gaming establishment, said remote terminal being located outside said gaming establishment, said gaming site being provided on said global computer network, the method comprising:

receiving, at said gaming server, personal identification information, game selection information, and wager information from a player accessing said gaming site via said remote terminal, said remote terminal being connected to said global computer network;

randomly generating outcome data at one of said gaming server and a gaming machine communicatively coupled to said gaming server, said outcome data being generated for a game selected according to said game selection information, said gaming machine being located at said gaming establishment;

receiving said outcome data at said gaming server; and

transmitting said outcome data from said gaming server to said gaming site for display to said player on said remote terminal in text or graphical form.

39. (New) A method for playing a gaming machine located inside a gaming establishment from a remote terminal located outside the gaming establishment comprising:

establishing a communication link between said remote terminal and a gaming site on a global computer network, said gaming site in communication with a gaming server for collecting outcome data from gaming machines located inside the gaming establishment;

selecting a gaming machine at said gaming establishment using said remote terminal;

making a wager to play the selected gaming machine;

receiving outcome data, including game outcome, at said remote terminal resulting from a play of said gaming machine; and

generating a payout if said game outcome meets predetermined criteria.

40. (New) The method of claim 39 wherein said outcome data comprises information identifying the value of said payout; and further comprising the step of using said payout information to simulate a display of said game outcome at said remote location.
41. (New) The method of claim 39 further comprising using said outcome data to simulate a display of said game outcome on said remote terminal.
42. (New) The method of claim 39, wherein said selected gaming machine comprises a slot machine and wherein said game outcome data includes a reel position.
43. (New) The method of claim 39 wherein said selected gaming machine comprises a video poker machine including a display for displaying a poker hand.
44. (New) The method of claim 39 wherein said step of receiving outcome data includes receiving outcome data from a plurality of gaming machines for remote play.
45. (New) The method of claim 44 wherein said step of receiving outcome data includes receiving a gaming machine identifier.
46. (New) The method of claim 44 wherein said step of receiving outcome data includes receiving a gaming machine type.
47. (New) The method of claim 44 wherein said step of receiving outcome data includes receiving player preferences.
48. (New) The method of claim 39 wherein said selected gaming machine comprises a slot machine and wherein said game outcome comprises information identifying a reel position of said gaming machine; and further comprising the step of using said outcome information to display said reel position on said remote terminal.
49. (New) The method of claim 39 and further including the steps of receiving a player identifier; and transmitting said player identifier for identification of said player.

50. (New) The method of claim 39 wherein said game outcome results from the server initiating game play on the selected gaming machine.

51. (New) The method of claim 39 wherein said game outcome results from the manual game play on the selected gaming machine.

52. (New) A remote computer for the remote play of a local gaming machine located within a gaming establishment and connected to a gaming server, the remote computer being located outside said gaming establishment, said remote computer connected to a gaming site through a global computing network served by said gaming server, said remote computer comprising:

a microprocessor;

memory connected to said microprocessor and including instructions for controlling said microprocessor; and

said microprocessor being operative with said instructions in said memory to:

receive information identifying a plurality of local gaming machines located within said gaming establishment from a gaming server;

transmit data selecting of at least one said plurality of local gaming machines for remote play;

receive a text or graphical outcome resulting from a local play of each said selected local gaming machine; and

generate a payout if said outcome meets predetermined criteria.

53. (New) The remote computer of claim 52 wherein said selected gaming machine comprises a slot machine and wherein said outcome includes a reel position.

54. (New) The remote computer of claim 52 wherein said operation of receiving information includes receiving information selecting at least two of said plurality of local gaming machines for remote play.

55. (New) The remote computer of claim 52 wherein said operation of receiving information includes receiving a gaming machine identifier.

56. (New) The remote computer of claim 52 wherein said operation of receiving information includes receiving a gaming machine type.

57. (New) The remote computer of claim 52 wherein said operation of receiving information includes receiving player preferences.

58. (New) The remote computer of claim 52 wherein said selected gaming machine comprises a video poker machine including a display for displaying a poker hand.

59. (New) The remote computer of claim 52 wherein said outcome comprises data identifying the value of said payout; and further comprising the operation of using said payout data to simulate a display of said outcome at said remote location.

60. (New) The remote computer of claim 52 wherein said outcome comprises information identifying a reel position of said selected gaming machine; and further comprising the operation of using said outcome data to display said reel position at said remote location.

61. (New) The remote computer of claim 52 further including the operations of: receiving a player identifier; and transmitting said player identifier for identification of said player.

62. (New) A remote computer located outside a gaming establishment, said gaming establishment having a plurality of gaming machines linked by a gaming server, said remote computer connected to a gaming site through a global computing network served by said gaming server comprising:

means for receiving information identifying a plurality of local gaming machines each engaged in play within said gaming establishment;

means for transmitting data from selecting at least one of said plurality of local gaming machines for information transfer;

means for receiving a text or graphical outcome resulting from a play of said selected local gaming machines; and

means for generating a payout if said outcome meets predetermined criteria.





## REMARKS

Claims 37-62 are pending in this application. Claims 1-21, 35 and 36 have been cancelled. Claims 37-62 have been added.

### Specification

The Examiner noted that the Brief Description of the Drawings was missing from the specification. The drawing description section has been added to the specification, listing and describing FIGS. 1, 2a and 2b.

The specification was objected to because the specification contained hyperlinks. The hyperlinks have been deleted from the specification.

### Claim Rejections - 35 U.S.C. § 102

Claims 1-10, 21, 35 and 36 were rejected under 35 U.S.C. § 102 as being anticipated by U.S. Patent No. 6,361,437 to Walker ("Walker"). The Office Action alleges that Walker discloses the invention. The Applicant respectfully disagrees on the basis that significant claim features and limitations are missing from Walker.

The present invention can be distinguished from Walker by the fact that the present invention utilizes a worldwide computer network (e.g., the Internet) to remotely connect to a gaming establishment's gaming machines. To accomplish this, the present invention uses an internet website that connects remote terminals over the Internet to a gaming establishment's server which, in turn, is in communication with the gaming establishment's gaming machines.

In contrast, Walker utilizes a Local Area Network (LAN) to connect the gaming establishment's gaming machines through the gaming establishment's slot network server.

Walker states:

*The remote wagering terminals 5 also communicate with the slot network server 4 being coupled to the slot network server 4 via a remote wagering terminal network 10. The remote wagering terminal network 10 is a conventional local area network that is controlled by the server 4. (Column 4, lines 19-23.)*

The local area network described by Walker is **not** a global computing network (Internet), as it only serves terminals that are directly connected to this LAN. Local area networks typically are installed within a very limited geographical range, generally within a building, or, as in this case, within the gaming establishment itself. The remote terminals, the gaming machines, and the slot network server, all connected by a LAN, are all generally located within the gaming establishment. This is in sharp contrast to the present invention which utilizes a global computing network that allows any personal computer to access a gaming establishment's gaming machines from anywhere in the world. The remote terminals described in Walker's patent must be connected to a local area network, preventing them from being used on a global basis.

Furthermore, the remote terminals described by Walker have player tracking card readers and even potentially coin hoppers. Walker states:

*Each remote wagering terminal 5 includes a keypad 7 and a player tracking card reader 8. (Column 4, lines 23-25.)*

*. . . each remote wagering terminal 5 has a starting controller 580, a hopper controller 590, and a hopper 600. As with each slot machine 2, these components are coupled to the CPU 510. (Column 8, lines 9-12.)*

Walker's terminals, because of their specialized equipment (i.e., player tracking card readers and potentially coin hoppers), are intended for use in a limited area where such peripheral devices can be maintained by the gaming establishment, and confirms the localized nature of the remote terminals. This is in contrast to use of the Internet and an internet gaming site to relay

game outcomes from a gaming machine through a gaming server to a personal computer anywhere in the world.

To further overcome this rejection, all remaining independent claims recite a “gaming site” and a “gaming server” to enable gaming machine outcome data to be delivered to a remote terminal over a “global computing network”. For example, independent claim 37 states:

*. . . accessing, via a remote terminal, a gaming site on a global computer network connected to said remote terminal; . . . said outcome data being generated by one of a gaming server and a gaming machine at said gaming establishment and relayed to said gaming site.*

Claim 38 also recites the key components required for an Internet connected wagering method, which states in apart:

*A remote gaming method using a gaming server, a remote terminal, and a gaming site on a global computer network, said gaming server being located at a gaming establishment, said remote terminal being located outside said gaming establishment, said gaming site being provided on said global computer network . . .*

Claim 39 also recites the key components required for an Internet connected wagering method, which states in apart:

*. . . establishing a communication link between said remote terminal and a gaming site on a global computer network, said gaming site in communication with a server for collecting outcome data from gaming machines located inside the gaming establishment; . . .*

Claim 52 also recites the components required for the Internet connection of the remote terminals to the gaming machines:

*A remote computer for the remote play of a local gaming machine . . . connected to a gaming server, said remote computer connected to a gaming site through a global computing network . . .*

Claim 62 also recites the components required for the Internet connection of the remote terminals to the gaming machines:

*A remote computer located outside a gaming establishment . . . having a plurality of gaming machines linked by a gaming server, said remote computer connected to a gaming site through a global computing network served by said gaming server . . .*

The Applicant maintains that the use of a worldwide global computing network (e.g., the Internet) and a gaming site on that network to deliver gaming machine game outcomes from a gaming establishment to remote terminals anywhere in the world is a novel and non-obvious feature over Walker.

### **Conclusion**

The Applicant believes the claims are in condition for allowance, and action towards that end is earnestly solicited.

If there are any matters which may be resolved or clarified through a telephone interview, the Examiner is respectfully requested to contact the Applicant's undersigned attorney at the number indicated.

Respectfully submitted,

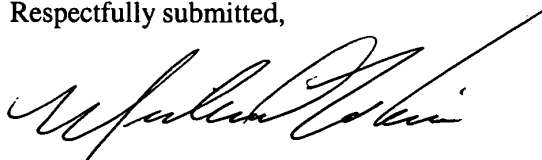

Date: March 5, 2003

---

Michael L. White  
Reg. No. 39,421  
(773) 961-1267  
Attorney for Applicant



UNITED STATES PATENT AND TRADEMARK OFFICE

UNITED STATES DEPARTMENT OF COMMERCE  
United States Patent and Trademark Office  
Address: COMMISSIONER OF PATENTS AND TRADEMARKS  
P.O. Box 1450  
Alexandria, Virginia 22313-1450  
www.uspto.gov

APPLICATION NO.	FILING DATE	FIRST NAMED INVENTOR	ATTORNEY DOCKET NO.	CONFIRMATION NO.
09/688,501	10/16/2000	Shridhar P. Joshi	47079-00077	3225

30223 7590 06/05/2003  
JENKENS & GILCHRIST, P.C.  
225 WEST WASHINGTON  
SUITE 2600  
CHICAGO, IL 60606

EXAMINER

RADA, ALEX P

ART UNIT PAPER NUMBER

3714

DATE MAILED: 06/05/2003

8

Please find below and/or attached an Office communication concerning this application or proceeding.

<b>Office Action Summary</b>	<b>Application No.</b> 09/688,501	<b>Applicant(s)</b> JOSHI, SHRIDHAR P.	
	<b>Examiner</b> Alex P. Rada	<b>Art Unit</b> 3714	

-- The MAILING DATE of this communication appears on the cover sheet with the correspondence address --

**Period for Reply**

A SHORTENED STATUTORY PERIOD FOR REPLY IS SET TO EXPIRE 3 MONTH(S) FROM THE MAILING DATE OF THIS COMMUNICATION.

- Extensions of time may be available under the provisions of 37 CFR 1.136(a). In no event, however, may a reply be timely filed after SIX (6) MONTHS from the mailing date of this communication.
- If the period for reply specified above is less than thirty (30) days, a reply within the statutory minimum of thirty (30) days will be considered timely.
- If NO period for reply is specified above, the maximum statutory period will apply and will expire SIX (6) MONTHS from the mailing date of this communication.
- Failure to reply within the set or extended period for reply will, by statute, cause the application to become ABANDONED (35 U.S.C. § 133).
- Any reply received by the Office later than three months after the mailing date of this communication, even if timely filed, may reduce any earned patent term adjustment. See 37 CFR 1.704(b).

**Status**

- 1)  Responsive to communication(s) filed on 17 March 2003.
- 2a)  This action is **FINAL**.                      2b)  This action is non-final.
- 3)  Since this application is in condition for allowance except for formal matters, prosecution as to the merits is closed in accordance with the practice under *Ex parte Quayle*, 1935 C.D. 11, 453 O.G. 213.

**Disposition of Claims**

- 4)  Claim(s) 37-62 is/are pending in the application.
- 4a) Of the above claim(s) \_\_\_\_\_ is/are withdrawn from consideration.
- 5)  Claim(s) \_\_\_\_\_ is/are allowed.
- 6)  Claim(s) 37-62 is/are rejected.
- 7)  Claim(s) \_\_\_\_\_ is/are objected to.
- 8)  Claim(s) \_\_\_\_\_ are subject to restriction and/or election requirement.

**Application Papers**

- 9)  The specification is objected to by the Examiner.
- 10)  The drawing(s) filed on \_\_\_\_\_ is/are: a)  accepted or b)  objected to by the Examiner.  
    Applicant may not request that any objection to the drawing(s) be held in abeyance. See 37 CFR 1.85(a).
- 11)  The proposed drawing correction filed on \_\_\_\_\_ is: a)  approved b)  disapproved by the Examiner.  
    If approved, corrected drawings are required in reply to this Office action.
- 12)  The oath or declaration is objected to by the Examiner.

**Priority under 35 U.S.C. §§ 119 and 120**

- 13)  Acknowledgment is made of a claim for foreign priority under 35 U.S.C. § 119(a)-(d) or (f).  
    a)  All    b)  Some \*    c)  None of:  
    1.  Certified copies of the priority documents have been received.  
    2.  Certified copies of the priority documents have been received in Application No. \_\_\_\_\_ .  
    3.  Copies of the certified copies of the priority documents have been received in this National Stage application from the International Bureau (PCT Rule 17.2(a)).  
    \* See the attached detailed Office action for a list of the certified copies not received.
- 14)  Acknowledgment is made of a claim for domestic priority under 35 U.S.C. § 119(e) (to a provisional application).  
    a)  The translation of the foreign language provisional application has been received.
- 15)  Acknowledgment is made of a claim for domestic priority under 35 U.S.C. §§ 120 and/or 121.

**Attachment(s)**

- |  |   |
|--|---|
| 1) <input checked="" type="checkbox"/> Notice of References Cited (PTO-892)                  | 4) <input type="checkbox"/> Interview Summary (PTO-413) Paper No(s). _____  |
| 2) <input type="checkbox"/> Notice of Draftsperson's Patent Drawing Review (PTO-948)         | 5) <input type="checkbox"/> Notice of Informal Patent Application (PTO-152) |
| 3) <input type="checkbox"/> Information Disclosure Statement(s) (PTO-1449) Paper No(s) _____ | 6) <input type="checkbox"/> Other:  |

**DETAILED ACTION**

***Response to Amendment***

In response to the amendment filed March 17, 2003 in which the applicant provides corrections to the disclosure, cancels claims 1-21 and 35-36, claims 22-34 withdrawn, adds new claims 37-62, and claims 37-62 are pending in this office action.

***Claim Rejections - 35 USC § 102***

1. The following is a quotation of the appropriate paragraphs of 35 U.S.C. 102 that form the basis for the rejections under this section made in this Office action:

A person shall be entitled to a patent unless –

(e) the invention was described in a patent granted on an application for patent by another filed in the United States before the invention thereof by the applicant for patent, or on an international application by another who has fulfilled the requirements of paragraphs (1), (2), and (4) of section 371(c) of this title before the invention thereof by the applicant for patent.

The changes made to 35 U.S.C. 102(e) by the American Inventors Protection Act of 1999 (AIPA) and the Intellectual Property and High Technology Technical Amendments Act of 2002 do not apply when the reference is a U.S. patent resulting directly or indirectly from an international application filed before November 29, 2000. Therefore, the prior art date of the reference is determined under 35 U.S.C. 102(e) prior to the amendment by the AIPA (pre-AIPA 35 U.S.C. 102(e)).

2. Claims 37 and 38 are rejected under 35 U.S.C. 102(e) as being anticipated by Roseman '984.

3. Roseman discloses accessing via a remote terminal on a global computer network (internet) connected to the remote terminal, providing personal identification information to the

gaming site, selecting a game of chance for remote play, placing a wager for playing the selected game, and receiving randomly-generated text or graphical outcome data at the remote terminal for the selected game and the outcome data being relayed to the gaming site as recited in claims 37 and 38.

4. Claims 39-46, 48, 50-56, 58-60, and 62 are rejected under 35 U.S.C. 102(e) as being anticipated by Wiltshire '602.

5. Wiltshire discloses a communication link between the remote terminal and a gaming site on a global computer network (internet), the gaming site in communication with a gaming server for outcome data from gaming machines located at a gaming establishment, selecting a gaming machine, making a wager to play the selected gaming machine, receiving outcome data including game outcome at the remote terminal resulting from play of the gaming machine, generating a payout, a microprocessor, and the memory connected to the microprocessor as recited in claims 39, 52, and 62; the outcome data having information identifying the value of the payout and simulate a display of the game outcome at the remote location as recited in claims 40 and 59; the outcome data to simulate a display of the game outcome on the remote terminal as recited in claim 41; the selected gaming machine is a slot machine wherein the outcome data includes reel position as recited in claims 42, 48, 53, and 60; the selected gaming machine is a video poker machine including a display for displaying a poker hand as recited in claims 43 and 58; the receiving outcome data includes receiving outcome data from a plurality of gaming machine form remote play as recited in claim 43; the outcome data includes receiving outcome data from a plurality of gaming machines for remote play as recited in claim 44; the outcome data includes a gaming machine identifier and gaming machine type as recited in claim 45-46 and 55-56; the



game outcome results from the server initiating game play on the selected gaming machine as recited in claim 50; the outcome results from the manual game play on the selected gaming machine as recited in claim 51; receiving information includes receiving information selecting at least two plurality of local gaming machines for remote play as recited in claim 54 (see whole document).

*Claim Rejections - 35 USC § 103*

6. The following is a quotation of 35 U.S.C. 103(a) which forms the basis for all obviousness rejections set forth in this Office action:

(a) A patent may not be obtained though the invention is not identically disclosed or described as set forth in section 102 of this title, if the differences between the subject matter sought to be patented and the prior art are such that the subject matter as a whole would have been obvious at the time the invention was made to a person having ordinary skill in the art to which said subject matter pertains. Patentability shall not be negated by the manner in which the invention was made.

7. Claims 47, 49, 57, and 61 is rejected under 35 U.S.C. 103(a) as being unpatentable over Wiltshire `602 in view of Walker `437.

8. Wiltshire discloses the claimed invention as discussed above except for the outcome data including receiving player preferences as recited in claims 47 and 57; a player identifier and transmitting the player identifier for identification of the player as recited in claims 49 and 61.

Walker teaches player preference data. By having player preferences and player identifiers, one of ordinary skill in the art would determine which game player is playing a particular gaming machine. Therefore, it would have been obvious to one of ordinary skill in the art at the time of the applicant's invention was made to modify Wiltshire to include outcome data including receiving player preferences as taught by Walker `437. To do so would distinguish and determine which game player is playing a particular gaming machine.

*Response to Arguments*

9. Applicant's arguments with respect to claims 39-62 have been considered but are moot in view of the new ground(s) of rejection.

*Conclusion*

10. Applicant's amendment necessitated the new ground(s) of rejection presented in this Office action. Accordingly, **THIS ACTION IS MADE FINAL**. See MPEP § 706.07(a). Applicant is reminded of the extension of time policy as set forth in 37 CFR 1.136(a).

A shortened statutory period for reply to this final action is set to expire THREE MONTHS from the mailing date of this action. In the event a first reply is filed within TWO MONTHS of the mailing date of this final action and the advisory action is not mailed until after the end of the THREE-MONTH shortened statutory period, then the shortened statutory period will expire on the date the advisory action is mailed, and any extension fee pursuant to 37 CFR 1.136(a) will be calculated from the mailing date of the advisory action. In no event, however, will the statutory period for reply expire later than SIX MONTHS from the date of this final action.

11. The prior art made of record and not relied upon is considered pertinent to applicant's disclosure.

Spaur '920, Xidos '149, and Karmarkar '709 all disclose different types of Internet gaming.

  
S. THOMAS HUGHES  
SUPERVISORY PATENT EXAMINER  
TECHNOLOGY CENTER 3700

Application/Control Number: 09/688,501  
Art Unit: 3714

Page 6

Any inquiry concerning this communication or earlier communications from the examiner should be directed to Alex P. Rada whose telephone number is 703-308-7135. The examiner can normally be reached on Monday - Friday, 08:00-16:00.

If attempts to reach the examiner by telephone are unsuccessful, the examiner's supervisor, Tom Hughes can be reached on 703-308-1806. The fax phone numbers for the organization where this application or proceeding is assigned are 703-872-9302 for regular communications and 703-872-9303 for After Final communications.

Any inquiry of a general nature or relating to the status of this application or proceeding should be directed to the receptionist whose telephone number is 703-308-1148.

ARZ  
apr  
May 28, 2003

#3

<b>Notice of References Cited</b>	Application/Control No. 09/688,501	Applicant(s)/Patent Under Reexamination JOSHI, SHRIDHAR P.	
	Examiner Alex P. Rada	Art Unit 3714	Page 1 of 1

**U.S. PATENT DOCUMENTS**

*	Document Number Country Code-Number-Kind Code	Date MM-YYYY	Name	Classification
*	A US-6,361,437	03-2002	Walker et al.	463/23
*	B US-6,409,602	06-2002	Wiltshire et al.	463/42
	C US-6,196,920	03-2001	Spaur et al.	463/42
	D US-5,851,149	12-1998	Xidos et al.	463/42
	E US-6,508,709	01-2003	Karmarkar, Jayant S.	463/42
	F US-			
	G US-			
	H US-			
	I US-			
	J US-			
	K US-			
	L US-			
	M US-			

**FOREIGN PATENT DOCUMENTS**

*	Document Number Country Code-Number-Kind Code	Date MM-YYYY	Country	Name	Classification
	N				
	O				
	P				
	Q				
	R				
	S				
	T				

**NON-PATENT DOCUMENTS**

*	Include as applicable: Author, Title Date, Publisher, Edition or Volume, Pertinent Pages)
	U
	V
	W
	X

\*A copy of this reference is not being furnished with this Office action. (See MPEP § 707.05(a).)  
Dates in MM-YYYY format are publication dates. Classifications may be US or foreign.

✓



BOX AF  
RESPONSE UNDER 37 C.F.R. § 1.116  
EXPEDITED PROCEDURE  
EXAMINING GROUP 3714

IN THE UNITED STATES PATENT AND TRADEMARK OFFICE

Application No. : 09/688,501  
Applicant : Shridhar P. Joshi  
Filed : October 16, 2000  
Title : Method Of Transferring Gaming Data On  
A Global Computer Network  
  
TC/A.U. : 3714  
Examiner : Alex P. Rada  
  
Docket No. : 47079-00077  
Customer No. : 30223

RECEIVED

SEP 10 2003

TECHNOLOGY CENTER R3700

*Amdt*  
*# 9/c*  
*(#2)*  
*9/12/03*  
*Bloss*

Commissioner for Patents  
Mail Stop AF  
P.O. Box 1450  
Alexandria, VA 22313-1450

CERTIFICATE OF MAILING

I hereby certify that this correspondence is being deposited with the United States Postal Service as first class mail, postage prepaid, in an envelope addressed to the Commissioner for Patents, Mail Stop AF, P.O. Box 1450, Alexandria, VA 22313-1450, on September 4, 2003.

Signature: *Janet L. Newmaker*  
Janet L. Newmaker

AMENDMENT AFTER FINAL

Dear Sir:

This is in response to the Office Action dated June 5, 2003. The shortened statutory period for response is three months from the mailing date, i.e., by September 5, 2003, and this response is being submitted within that time period. Please enter the following claim amendments and remarks into the record for this application.

Amendments to the claims are reflected in the listing of claims that begins on page 2 of this paper.

Remarks/Arguments begin on page 12 of this paper.

*Do Not Enter*



AF  
3700

Corres. and Mail  
**BOX AF**

**BOX AF**  
**RESPONSE UNDER 37 C.F.R. § 1.116**  
**EXPEDITED PROCEDURE**  
**EXAMINING GROUP 3714**

**IN THE UNITED STATES PATENT AND TRADEMARK OFFICE**

Application No. : 09/688,501  
 Applicant : Shridhar P. Joshi  
 Filed : October 16, 2000  
 Title : Method Of Transferring Gaming Data On  
 A Global Computer Network

TC/A.U. : 3714  
 Examiner : Alex P. Rada

Docket No. : 47079-00077  
 Customer No. : 30223

**RECEIVED**  
SEP 10 2003  
TECHNOLOGY CENTER R3700

Commissioner for Patents  
Mail Stop AF  
P.O. Box 1450  
Alexandria, VA 22313-1450

**CERTIFICATE OF MAILING**

I hereby certify that this correspondence is being deposited with the United States Postal Service as first class mail, postage prepaid, in an envelope addressed to the Commissioner for Patents, Mail Stop AF, P.O. Box 1450, Alexandria, VA 22313-1450, on September 4, 2003.

Signature: Janet L. Newmaker  
Janet L. Newmaker

**AMENDMENT TRANSMITTAL**

Dear Sir:

Transmitted herewith is an "Amendment After Final" for this application.

The Applicant is other than a small entity.

The proceedings herein are for a patent application, and the provisions of 37 C.F.R. § 1.136 apply.

The Applicant believes that no extension of time is required. This conditional petition is being made, however, to provide for the possibility that the Applicant has inadvertently overlooked the need for a petition for extension of time.

The fee for claims (37 C.F.R. § 1.16(b)-(d)) has been calculated as shown below.

	Claims Remaining	Highest No. Paid For	Extra	Small Entity	Large Entity
Total	26	36	0 x	\$ 9 = \$	\$ 18 = \$ 0
Independent	5	8	0 x	\$ 42 = \$	\$ 84 = \$ 0
Multiple Dependent Claim Presented				\$ 140 = \$	\$ 280 = \$ 0
<b>TOTAL ADDITIONAL FEE</b>					\$ 0

There is no additional fee for claims.

The Commissioner is hereby authorized to charge any additional fees which may be required, or credit any overpayment, to Deposit Account No. 10-0447 (47079-00077). A duplicate copy of this Transmittal is enclosed for that purpose.

Respectfully submitted,

Date: September 4, 2003

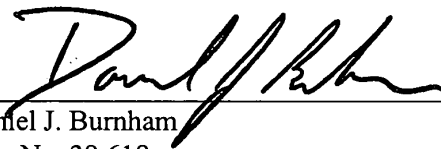
  
 \_\_\_\_\_  
 Daniel J. Burnham  
 Reg. No. 39,618  
 Jenkens & Gilchrist  
 225 West Washington Street, Suite 2600  
 Chicago, IL 60606-3418  
 (312) 425-3900  
 Attorney for Applicant

**Listing of Claims:**

This listing of claims will replace all prior versions and listing of claims in the application.

---

1-21. (Cancelled)

22. (Withdrawn) A method for transferring gaming data on a global computer network comprising:

receiving player identification information from outside of a gaming establishment;

analyzing said player identification information;

requesting player input regarding a random event;

receiving and analyzing said input;

generating a random number within said gaming establishment;

interpreting said random number to determine a text or graphical outcome; and

transmitting said outcome to a player through said global computer network.

23. (Withdrawn) The method of Claim 22, wherein said random event takes place in a microprocessor within a gaming machine located within said gaming establishment.

24. (Withdrawn) The method of Claim 22, wherein said random event takes place in a microprocessor within a gaming establishment server.



25. (Withdrawn) The method of Claim 22, wherein said global computer network is the Internet.

26. (Withdrawn) A method of receiving transferred data via a global computer network, comprising:

accessing a global computer network from outside a gaming establishment;

inputting identification information into said global computer network;

gaining access to a server within said gaming establishment;

requesting the generation of a random number, said random number being generated from within said gaming establishment; and

receiving a text or graphical outcome of said random number generation via said global computer network.

27. (Withdrawn) The method of Claim 26, wherein said global computer network is the Internet.

28. (Withdrawn) The method of Claim 26, wherein said generation of said random number is accomplished at a gaming machine within said gaming establishment.

29. (Withdrawn) The method of Claim 26, wherein said generation of said random number is accomplished at a gaming establishment server.

30. (Withdrawn) The method of Claim 26, wherein the step of receiving is accomplished via said global computer network.

31. (Withdrawn) The method of Claim 26, wherein the step of receiving is accomplished through the Internet.

32. (Withdrawn) An interactive site on a global computer network comprising:  
a page including one or more game choices to allow a player to participate in a remote  
c1 random event;  
data means to input data;  
outcome means to receive text or graphical outcomes of a remote random event; and  
notification means to notify said player of said outcomes.

33. (Withdrawn) The interactive web site of Claim 32, wherein said page is an Internet-based World Wide Web page.

34. (Withdrawn) The interactive web site of Claim 32, wherein said remote random event occurs in a slot machine.

35-36. (Cancelled)

37. (Currently Amended) A remote gaming method comprising:

accessing, via a remote terminal, a gaming site on a global computer network connected to said remote terminal;

providing, via said remote terminal, personal identification information to said gaming site;

selecting, via said remote terminal, a game of chance on a gaming machine located at a gaming establishment for remote play, said remote terminal being located outside said gaming establishment;

placing, via said remote terminal, a wager for playing said selected game; and

receiving randomly-generated text or graphical outcome data at said remote terminal for said selected game, said outcome data being generated by ~~the a gaming server and~~ a gaming machine at said gaming establishment and relayed to said gaming site.

C1

38. (Currently Amended) A remote gaming method using a gaming server, a remote terminal, and a gaming site on a global computer network, said gaming server being located at a gaming establishment, said remote terminal being located outside said gaming establishment, said gaming site being provided on said global computer network, the method comprising:

receiving, at said gaming server, personal identification information, game selection information, and wager information from a player accessing said gaming site via said remote terminal, said remote terminal being connected to said global computer network;

randomly generating outcome data at ~~one of said gaming server~~ and a gaming machine communicatively coupled to said gaming server, said outcome data being generated for a game selected according to said game selection information, said gaming machine being located at said gaming establishment;

receiving said outcome data at said gaming server; and

transmitting said outcome data from said gaming server to said gaming site for display to said player on said remote terminal in text or graphical form.

c |

39. (Previously Presented) A method for playing a gaming machine located inside a gaming establishment from a remote terminal located outside the gaming establishment comprising:

establishing a communication link between said remote terminal and a gaming site on a global computer network, said gaming site in communication with a gaming server for collecting outcome data from gaming machines located inside the gaming establishment;

selecting a gaming machine at said gaming establishment using said remote terminal;

making a wager to play the selected gaming machine;

receiving outcome data, including game outcome, at said remote terminal resulting from a play of said gaming machine; and

generating a payout if said game outcome meets predetermined criteria.

40. (Previously Presented) The method of claim 39 wherein said outcome data comprises information identifying the value of said payout; and further comprising the step of using said payout information to simulate a display of said game outcome at said remote location.

41. (Previously Presented) The method of claim 39 further comprising using said outcome data to simulate a display of said game outcome on said remote terminal.

42. (Previously Presented) The method of claim 39, wherein said selected gaming machine comprises a slot machine and wherein said game outcome data includes a reel position.

C1

43. (Previously Presented) The method of claim 39 wherein said selected gaming machine comprises a video poker machine including a display for displaying a poker hand.

44. (Previously Presented) The method of claim 39 wherein said step of receiving outcome data includes receiving outcome data from a plurality of gaming machines for remote play.

45. (Previously Presented) The method of claim 44 wherein said step of receiving outcome data includes receiving a gaming machine identifier.

46. (Previously Presented) The method of claim 44 wherein said step of receiving outcome data includes receiving a gaming machine type.

47. (Previously Presented) The method of claim 44 wherein said step of receiving outcome data includes receiving player preferences.

48. (Previously Presented) The method of claim 39 wherein said selected gaming machine comprises a slot machine and wherein said game outcome comprises information identifying a reel position of said gaming machine; and further comprising the step of using said outcome information to display said reel position on said remote terminal.

C1

49. (Previously Presented) The method of claim 39 and further including the steps of receiving a player identifier; and transmitting said player identifier for identification of said player.

50. (Previously Presented) The method of claim 39 wherein said game outcome results from the server initiating game play on the selected gaming machine.

51. (Previously Presented) The method of claim 39 wherein said game outcome results from the manual game play on the selected gaming machine.

52. (Previously Presented) A remote computer for the remote play of a local gaming machine located within a gaming establishment and connected to a gaming server, the remote computer being located outside said gaming establishment, said remote computer connected to a gaming site through a global computing network served by said gaming server, said remote computer comprising:

a microprocessor;

memory connected to said microprocessor and including instructions for controlling said microprocessor; and

said microprocessor being operative with said instructions in said memory to:

c ( receive information identifying a plurality of local gaming machines located within said gaming establishment from a gaming server;

transmit data selecting of at least one said plurality of local gaming machines for remote play;

receive a text or graphical outcome resulting from a local play of each said selected local gaming machine; and

generate a payout if said outcome meets predetermined criteria.

53. (Previously Presented) The remote computer of claim 52 wherein said selected gaming machine comprises a slot machine and wherein said outcome includes a reel position.

54. (Previously Presented) The remote computer of claim 52 wherein said operation of receiving information includes receiving information selecting at least two of said plurality of local gaming machines for remote play.

55. (Previously Presented) The remote computer of claim 52 wherein said operation of receiving information includes receiving a gaming machine identifier.

56. (Previously Presented) The remote computer of claim 52 wherein said operation of receiving information includes receiving a gaming machine type.

C1

57. (Previously Presented) The remote computer of claim 52 wherein said operation of receiving information includes receiving player preferences.

58. (Previously Presented) The remote computer of claim 52 wherein said selected gaming machine comprises a video poker machine including a display for displaying a poker hand.

59. (Previously Presented) The remote computer of claim 52 wherein said outcome comprises data identifying the value of said payout; and further comprising the operation of using said payout data to simulate a display of said outcome at said remote location.



60. (Previously Presented) The remote computer of claim 52 wherein said outcome comprises information identifying a reel position of said selected gaming machine; and further comprising the operation of using said outcome data to display said reel position at said remote location.

61. (Previously Presented) The remote computer of claim 52 further including the operations of: receiving a player identifier; and transmitting said player identifier for identification of said player.

62. (Previously Presented) A remote computer located outside a gaming establishment, said gaming establishment having a plurality of gaming machines linked by a gaming server, said remote computer connected to a gaming site through a global computing network served by said gaming server comprising:

means for receiving information identifying a plurality of local gaming machines each engaged in play within said gaming establishment;

means for transmitting data from selecting at least one of said plurality of local gaming machines for information transfer;

means for receiving a text or graphical outcome resulting from a play of said selected local gaming machines; and

means for generating a payout if said outcome meets predetermined criteria.

---

### REMARKS

Claims 37-62 are pending in this application. Claims 1-21, 35 and 36 were previously cancelled. Claims 22-34 were previously withdrawn. Claims 39-62 were previously added. Claims 37 and 38 are currently amended.

#### **Claim Rejections Over Roseman - 35 U.S.C. § 102**

Claims 37 and 38 were rejected under 35 U.S.C. § 102 (e) as being anticipated by U.S. Patent No. 6,012,984 to Roseman ("Roseman"). The Office Action alleges that Roseman discloses the invention. The Applicant respectfully disagrees on the basis that significant claim features and limitations are missing from Roseman.

The present invention can be distinguished from Roseman by the fact that claims 37 and 38 utilize *a gaming machine* to provide random game outcomes to a gaming server. Claim 37 states ". . . said outcome data being generated by the gaming machine at said gaming establishment . . ." Claim 38 states ". . . generating outcome data at a gaming machine communicatively coupled to said gaming server . . ."

Roseman, in contrast, does not use a gaming machine, only a gaming server, to determine the random game outcome. Roseman states that ". . . the game server can be an extensible game engine for allowing the game server to service a plurality of different types of games, such as bingo, . . . as well as provide a plurality of different difficulty levels, themes or other variations in a particular game." (Roseman, column 3, lines 21-26.) Roseman further states that "FIG. 1 depicts a system 10 that comprises a computer network system for providing large arena gaming." (Roseman, column 4, lines 21-22.) By inspection, Roseman's FIG. 1 depicts that the

described large arena gaming system has no gaming machine. *Roseman is silent with respect to using a gaming machine to determine game outcomes.*

Consequently, Roseman is missing a fundamental limitation included in independent claims 37 and 38, i.e., *a gaming machine to determine game outcomes.*

#### **Claim Rejections Over Wiltshire - 35 U.S.C. § 102**

Claims 39-46, 48, 50-56, 58-60 and 62 were rejected under 35 U.S.C. § 102 (e) as being anticipated by U.S. Patent No. 6,409,602 to Wiltshire ("Wiltshire").

The cited claims can be distinguished from Wiltshire since the claims require *a gaming machine* to provide a random game outcome to the gaming server. Independent claims 39, 52 and 62 (and all their dependent claims 40-46, 48, 50, 51, 53-56 and 58-60) use a gaming machine to determine a random game outcome. Independent claim 39 requires "... a gaming server for collecting outcome data from gaming machines located inside the gaming establishment ...". Independent claim 52 requires receiving "... a text or graphical outcome resulting from a local play of each said selected local gaming machine ...". Dependent claim 62 requires "... means for receiving a text or graphical outcome resulting from a play of said selected local gaming machines ...".

*In contrast, Wiltshire does not use a gaming machine to determine game outcomes.* Wiltshire states that "... the gaming programs and the associated gaming display generation programs are executed entirely on the server/host computer, with only input wagering and output screen display related operations being executed on the client/terminal computers ...". (Wiltshire, column 2, lines 45-49.) Wiltshire further states that "[a] computer gaming system 100, in accordance to one embodiment of the invention, is shown in FIG. 1A." (Wiltshire,

column 3, lines 61-62.) Inspection of Wiltshire's FIG. 1A shows no gaming machine. *Wiltshire is silent with respect to using a gaming machine to determine game outcomes.*

Consequently, Wiltshire is missing a fundamental limitation included in independent claims 39, 52 and 62 (and all their associated dependent claims), i.e., *a gaming machine to determine game outcomes.*

#### **Claim Rejections Over Wiltshire In View Of Walker - 35 U.S.C. § 103**

Claims 47, 49, 57 and 61 were rejected under 35 U.S.C. § 103 (a) as being unpatentable over Wiltshire in view of U.S. Patent No. 6,361,437 to Walker ("Walker"). The Office Action alleges that Wiltshire discloses the claimed invention except for "... the outcome data including receiving player preferences as recited in claims 47 and 57; a player identifier and transmitting the player identifier for identification of the player as recited in claims 49 and 61." The Applicant believes, for the following reasons, that the present invention is novel and nonobvious over Wiltshire in view of Walker.

#### **The Proposed Modification Cannot Change The Principle Of Operation Of The Reference**

Wiltshire's principle objective is to "drastically reduce the cost of gaming stations." (Wiltshire, Abstract.) Wiltshire emphasizes the point in the summary of the invention stating, "[t]he present invention provides a computer gaming system and method of operation thereof that both drastically reduces the cost and substantially increases the tamper resistance of individual gaming stations." (Wiltshire, column 2, lines 22-25.)

To accomplish this objective, Wiltshire's operating principle is for the gaming programs to be "executed entirely on the server/host computer." (Wiltshire, Abstract.) Wiltshire further states that "[t]his functionality is implemented by executing various gaming and related game

management programs exclusively on a server/host computer . . .” (Wiltshire, column 2, lines 35-37.) Wiltshire summarizes, stating, “[s]ince the gaming programs and the associated gaming display generation programs are executed entirely on the server/host computer . . . the cost of the hardware and software required for each client/terminal computer is greatly reduced.” (Wiltshire, column 2, lines 45-51.)

Any suggestion to modify Wiltshire’s central server/host computer with the addition of gaming machines to determine game outcome completely changes Wiltshire’s principle of operation. Such a suggestion destroys Wiltshire’s operating principle of centralizing the execution of game programs on a single central computer. The proposed modification of adding gaming machines increases the cost of the gaming system. This is directly counter to Wiltshire’s expressed desire to reduce costs with one centralized central computer. In addition, adding gaming machines increases the potential for tampering with the gaming machines themselves. This, too, is directly counter to Wiltshire’s expressed desire to increase security with one centralized central computer. In fact, Wiltshire’s entire design principle centers on the elimination of gaming machines. Consequently, this proposed modification changes *Wiltshire’s principle of operation by executing gaming programs on a gaming machine rather than on the central server/host computer as taught by Wiltshire.*

#### **The Wiltshire Reference Teaches Away**

Not only does the proposed modification change the principle of operation of the Wiltshire reference, it also teaches away from Wiltshire. Wiltshire teaches executing the gaming programs on a central host/server computer to reduce costs and to increase security. To accomplish these objectives, Wiltshire requires that “. . . the gaming programs are executed

entirely on a server/host computer . . .” (Wiltshire, Abstract.) The suggested modification requires the addition of gaming machines in communication with a central computer to determine game outcomes. *This teaches away from Wiltshire’s express objective of eliminating gaming machines to decrease system costs and increase system security.* Consequently, Wiltshire’s invention teaches away from the use of gaming machines to execute and determine game outcomes.

### Conclusion

For all the reasons listed and described above, the Applicant believes that the claims are novel and nonobvious over the prior art. The Applicant further believes the claims are in condition for allowance, and action towards that end is earnestly solicited.

If any matters may be resolved or clarified through a telephone interview, the Examiner is respectfully requested to contact the Applicant’s undersigned attorney at the number shown.

Respectfully submitted,



Michael L. White  
Reg. No. 39,421  
(773) 961-1267  
Attorney for Applicant

Date: August 28, 2003



UNITED STATES PATENT AND TRADEMARK OFFICE

UNITED STATES DEPARTMENT OF COMMERCE  
United States Patent and Trademark Office  
Address: COMMISSIONER FOR PATENTS  
P.O. Box 1450  
Alexandria, Virginia 22313-1450  
www.uspto.gov

*cu*

APPLICATION NO.	FILING DATE	FIRST NAMED INVENTOR	ATTORNEY DOCKET NO.	CONFIRMATION NO.
09/688,501	10/16/2000	Shridhar P. Joshi	47079-00077	3225

30223      7590      09/23/2003  
JENKENS & GILCHRIST, P.C.  
225 WEST WASHINGTON  
SUITE 2600  
CHICAGO, IL 60606

EXAMINER

RADA, ALEX P

ART UNIT      PAPER NUMBER

3714

DATE MAILED: 09/23/2003

*10*

Please find below and/or attached an Office communication concerning this application or proceeding.

**Advisory Action**

Application No.

09/688,501

Applicant(s)

JOSHI, SHRIDHAR P.

Examiner

Alex P. Rada

Art Unit

3714

--The MAILING DATE of this communication appears on the cover sheet with the correspondence address --

THE REPLY FILED 08 September 2003 FAILS TO PLACE THIS APPLICATION IN CONDITION FOR ALLOWANCE. Therefore, further action by the applicant is required to avoid abandonment of this application. A proper reply to a final rejection under 37 CFR 1.113 may only be either: (1) a timely filed amendment which places the application in condition for allowance; (2) a timely filed Notice of Appeal (with appeal fee); or (3) a timely filed Request for Continued Examination (RCE) in compliance with 37 CFR 1.114.

**PERIOD FOR REPLY** [check either a) or b)]

- a)  The period for reply expires 3 months from the mailing date of the final rejection.
- b)  The period for reply expires on: (1) the mailing date of this Advisory Action, or (2) the date set forth in the final rejection, whichever is later. In no event, however, will the statutory period for reply expire later than SIX MONTHS from the mailing date of the final rejection. ONLY CHECK THIS BOX WHEN THE FIRST REPLY WAS FILED WITHIN TWO MONTHS OF THE FINAL REJECTION. See MPEP 706.07(f).

Extensions of time may be obtained under 37 CFR 1.136(a). The date on which the petition under 37 CFR 1.136(a) and the appropriate extension fee have been filed is the date for purposes of determining the period of extension and the corresponding amount of the fee. The appropriate extension fee under 37 CFR 1.17(a) is calculated from: (1) the expiration date of the shortened statutory period for reply originally set in the final Office action; or (2) as set forth in (b) above, if checked. Any reply received by the Office later than three months after the mailing date of the final rejection, even if timely filed, may reduce any earned patent term adjustment. See 37 CFR 1.704(b).

- 1.  A Notice of Appeal was filed on \_\_\_\_\_. Appellant's Brief must be filed within the period set forth in 37 CFR 1.192(a), or any extension thereof (37 CFR 1.191(d)), to avoid dismissal of the appeal.
- 2.  The proposed amendment(s) will not be entered because:
  - (a)  they raise new issues that would require further consideration and/or search (see NOTE below);
  - (b)  they raise the issue of new matter (see Note below);
  - (c)  they are not deemed to place the application in better form for appeal by materially reducing or simplifying the issues for appeal; and/or
  - (d)  they present additional claims without canceling a corresponding number of finally rejected claims.

NOTE: See Continuation Sheet.

- 3.  Applicant's reply has overcome the following rejection(s): \_\_\_\_\_.
- 4.  Newly proposed or amended claim(s) \_\_\_\_\_ would be allowable if submitted in a separate, timely filed amendment canceling the non-allowable claim(s).
- 5.  The a)  affidavit, b)  exhibit, or c)  request for reconsideration has been considered but does NOT place the application in condition for allowance because: \_\_\_\_\_.
- 6.  The affidavit or exhibit will NOT be considered because it is not directed SOLELY to issues which were newly raised by the Examiner in the final rejection.
- 7.  For purposes of Appeal, the proposed amendment(s) a)  will not be entered or b)  will be entered and an explanation of how the new or amended claims would be rejected is provided below or appended.

The status of the claim(s) is (or will be) as follows:

Claim(s) allowed: \_\_\_\_\_.

Claim(s) objected to: \_\_\_\_\_.

Claim(s) rejected: 37-62

Claim(s) withdrawn from consideration: \_\_\_\_\_.

- 8.  The proposed drawing correction filed on \_\_\_\_\_ is a)  approved or b)  disapproved by the Examiner.
- 9.  Note the attached Information Disclosure Statement(s) (PTO-1449) Paper No(s). \_\_\_\_\_.
- 10.  Other: \_\_\_\_\_

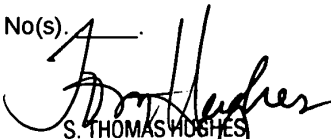
  
S. THOMAS HUGHES  
SUPERVISORY PATENT EXAMINER  
TECHNOLOGY CENTER 3700



Continuation of 2. NOTE: The proposed changes of "said outcome data being generated by a gaming server and a gaming machine at said gaming establishment" to "said outcome data being generated by the gaming machine at said gaming establishment" raises new issues and would require further searching and consideration..

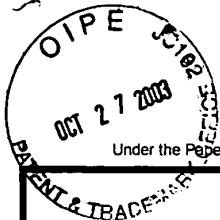

10-29-03

11-4783CE [37X] RCE

PTO/SB/30 (08-00) Approved for use through 10/31/02. OMB 0651-0031 U.S. Patent and Trademark Office: U.S. DEPARTMENT OF COMMERCE Under the Paperwork Reduction Act of 1995, no persons are required to respond to a collection of information unless it displays a valid OMB control number.

# REQUEST FOR CONTINUED EXAMINATION (RCE) TRANSMITTAL

Subsection (b) of 35 U.S.C. § 132, effective on May 29, 2000, provides for continued examination of a utility or plant application filed on or after June 8, 1995. See The American Inventors Protection Act of 1999 (AIPA).

Application Number	09/688,501
Filing Date	October 16, 2000
First Named Inventor	Shridar P. Joshi
Group Art Unit	3714
Examiner Name	Alex P. Rada
Attorney Docket Number	47079-00077

This is a request for Continued Examination (RCE) under 37 C.F.R. § 1.114 of the above-identified application. **NOTE:** 37 C.F.R. § 1.114 is effective on May 29, 2000. If the above identified application was filed prior to May 29, 2000, applicant may wish to consider filing a continued prosecution application (CPA) under 37 C.F.R. § 1.53 (d) (PTO/SB/29) instead of a RCE to be eligible for the patent term adjustment provisions of the AIPA. See Changes to Application Examination and Provisional Application Practice, Final Rule, 65 Fed. Reg. 50092 (Aug. 16, 2000); Interim Rule, 65 Fed. Reg. 14865 (Mar. 20, 2000), 1233 Off. Gaz. Pat. Office 47 (Apr. 11, 2000), which established RCE practice.

### 1. Submission required under 37 C.F.R. §

- a.  Previously submitted
  - i.  Consider the amendment(s)/reply under 37 C.F.R. § 1.116 previously filed on September 4, 2003 (Any unentered amendment(s) referred to above will be entered).
  - ii.  Consider the arguments in the Appeal Brief or Reply Brief previously filed on
  - iii.  Other
- b.  Enclosed
  - i.  Amendment/Reply
  - ii.  Affidavit(s)/Declaration(s)
  - iii.  Information Disclosure Statement (IDS)
  - iv.  Other Petition For Extension Of Time

RECEIVED  
OCT 31 2003  
TECHNOLOGY CENTER R3700

### 2. Miscellaneous

- a.  Suspension of action on the above-identified application is requested under 37 C.F.R. § 1.103(c) for a period of \_\_\_\_\_ months. (Period of suspension shall not exceed 3 months; Fee under 37 C.F.R. § 1.17(i) required)
- b.  Other

### 3. Fees

- The RCE fee under 37 C.F.R. § 1.17(e) is required by 37 C.F.R. § 1.114 when the RCE is filed.
- a.  The Director is hereby authorized to charge the following fees, or credit any overpayments, to Deposit Account No. 10-0447 (47079-00077)
  - i.  RCE fee required under 37 C.F.R. § 1.17(e)      \$ 10/30/2003 BABRAHA1 00000055 09688501
  - ii.  Extension of time fee (37 C.F.R. §§ 1.136 and 1.17)      01 FC:1801
  - iii.  Other      770.00 OP
- b.  Check in the amount of \$1,190.00 enclosed
- c.  Payment by credit card (Form PTO-2038 enclosed)

### SIGNATURE OF APPLICANT, ATTORNEY, OR AGENT REQUIRED

Name (Print/Type)	Daniel J. Burnham	Registration No. (Attorney/Agent)	39,618
Signature		Date	October 27, 2003

### CERTIFICATE OF MAILING OR TRANSMISSION

I hereby certify that this correspondence is being deposited with the United States Postal Service "EXPRESS MAIL POST OFFICE TO ADDRESSEE" service (Express Mail No. EL 831842246 US) under 37 C.F.R. 1.10 on the date indicated below and is addressed to: Commissioner For Patents, Mail Stop RCE, P.O. Box 1450, Alexandria, VA 22313-1450.

Name (Print/Type)	Janet L. Newmaker	Date	October 27, 2003
Signature			

Burden Hour Statement: This form is estimated to take 0.2 hours to complete. Time will vary depending upon the needs of the individual case. Any comments on the amount of time you are required to complete this form should be sent to the Chief Information Officer, U.S. Patent and Trademark Office, Washington, DC 20231. DO NOT SEND FEES OR COMPLETED FORMS TO THIS ADDRESS. SEND Fees and Completed Forms to the following address: Commissioner for Patents, Box RCE, Washington, DC 20231.

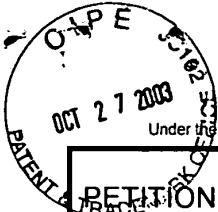

Approved for use through 10/31/2002. OMB 0651-0031  
U.S. Patent and Trademark Office: U.S. DEPARTMENT OF COMMERCE  
Under the Paperwork Reduction Act of 1995, no persons are required to respond to a collection of information unless it displays a valid OMB control number.

*Ed Johnson*  
11-4-03  
2003

<b>PETITION FOR EXTENSION OF TIME UNDER 37 CFR 1.136(a)</b>	Docket Number (Optional) 47079-00077
---	---

In re Application of	Shridhar P. Joshi		
Application Number	09/688,501	Filed	10/16/00
For	Method Of Transferring Gaming Data On A Global Computer Network		
Group Art Unit	3714	Examiner	Alex P. Rada

This is a request under the provisions of 37 CFR 1.136(a) to extend the period for filing a reply in the above identified application.

The requested extension and appropriate non-small-entity fee are as follows (check time period desired):

- One month (37 CFR 1.17(a)(1)) \$ \_\_\_\_\_
- Two months (37 CFR 1.17(a)(2)) \$420.00
- Three months (37 CFR 1.17(a)(3)) \$ \_\_\_\_\_
- Four months (37 CFR 1.17(a)(4)) \$ \_\_\_\_\_
- Five months (37 CFR 1.17(a)(5)) \$ \_\_\_\_\_

Applicant claims small entity status. See 37 CFR 1.27. Therefore, the fee amount shown above is reduced by one-half, and the resulting fee is: \$ \_\_\_\_\_

- A check in the amount of the fee is enclosed.
- Payment by credit card. Form PTO-2038 is attached.
- The Commissioner has already been authorized to charge fees in this application to a Deposit Account.
- The Commissioner is hereby authorized to charge any fees which may be required, or credit any overpayment, to Deposit Account Number 10-0447/47079-00077. have enclosed a duplicate copy of this sheet.

RECEIVED  
OCT 31 2003  
TECHNOLOGY CENTER

- I am the  applicant/inventor  
 assignee of record of the entire interest. See 37 CFR 3.71.  
 Statement under 37 CFR 3.73(b) is enclosed. (Form PTO/SB/96).  
 attorney or agent of record.  
 attorney or agent under 37 CFR 1.34(a).  
 Registration number if acting under 37 CFR 1.34(a) \_\_\_\_\_

**WARNING: Information on this form may become public. Credit card information should not be included on this form. Provide credit card information and authorization on PTO-2038.**

October 27, 2003  
Date

*Daniel J. Burnham*  
Signature

10/30/2003 BABRAHA1 00000055 09688501  
02 FC:1252 420.00 OP

Daniel J. Burnham  
Typed or printed name

NOTE: Signatures of all of the inventors or assignees of record of the entire interest or their representative(s) are required. Submit multiple forms if more than one signature is required, see below.

<input checked="" type="checkbox"/> Total of <u>1</u> form is submitted.
--

Burden Hour Statement: This form is estimated to take 0.1 hours to complete. Time will vary depending upon the needs of the individual case. Any comments on the amount of time you are required to complete this form should be sent to the Chief Information Officer, U.S. Patent and Trademark Office, Washington, DC 20231. DO NOT SEND FEES OR COMPLETED FORMS TO THIS ADDRESS. SEND TO: Commissioner for Patents, Washington, DC 20231.



UNITED STATES PATENT AND TRADEMARK OFFICE

UNITED STATES DEPARTMENT OF COMMERCE  
United States Patent and Trademark Office  
Address: COMMISSIONER FOR PATENTS  
P.O. Box 1450  
Alexandria, Virginia 22313-1450  
www.uspto.gov

on 2

APPLICATION NO.	FILING DATE	FIRST NAMED INVENTOR	ATTORNEY DOCKET NO.	CONFIRMATION NO.
09/688,501	10/16/2000	Shridhar P. Joshi	47079-00077	3225
30223	7590	12/17/2003	EXAMINER	
JENKENS & GILCHRIST, P.C. 225 WEST WASHINGTON SUITE 2600 CHICAGO, IL 60606			RADA, ALEX P	
			ART UNIT	PAPER NUMBER
			3714	

DATE MAILED: 12/17/2003

Please find below and/or attached an Office communication concerning this application or proceeding.

4

<b>Office Action Summary</b>	<b>Application No.</b> 09/688,501	<b>Applicant(s)</b> JOSHI, SHRIDHAR P.	
	<b>Examiner</b> Alex P. Rada	<b>Art Unit</b> 3714	

-- The MAILING DATE of this communication appears on the cover sheet with the correspondence address --

**Period for Reply**

A SHORTENED STATUTORY PERIOD FOR REPLY IS SET TO EXPIRE 3 MONTH(S) FROM THE MAILING DATE OF THIS COMMUNICATION.

- Extensions of time may be available under the provisions of 37 CFR 1.136(a). In no event, however, may a reply be timely filed after SIX (6) MONTHS from the mailing date of this communication.
- If the period for reply specified above is less than thirty (30) days, a reply within the statutory minimum of thirty (30) days will be considered timely.
- If NO period for reply is specified above, the maximum statutory period will apply and will expire SIX (6) MONTHS from the mailing date of this communication.
- Failure to reply within the set or extended period for reply will, by statute, cause the application to become ABANDONED (35 U.S.C. § 133).
- Any reply received by the Office later than three months after the mailing date of this communication, even if timely filed, may reduce any earned patent term adjustment. See 37 CFR 1.704(b).

**Status**

- 1)  Responsive to communication(s) filed on 27 October 2003.
- 2a)  This action is FINAL.                      2b)  This action is non-final.
- 3)  Since this application is in condition for allowance except for formal matters, prosecution as to the merits is closed in accordance with the practice under *Ex parte Quayle*, 1935 C.D. 11, 453 O.G. 213.

**Disposition of Claims**

- 4)  Claim(s) 39-62 is/are pending in the application.
  - 4a) Of the above claim(s) \_\_\_\_\_ is/are withdrawn from consideration.
- 5)  Claim(s) \_\_\_\_\_ is/are allowed.
- 6)  Claim(s) 39-62 is/are rejected.
- 7)  Claim(s) \_\_\_\_\_ is/are objected to.
- 8)  Claim(s) \_\_\_\_\_ are subject to restriction and/or election requirement.

**Application Papers**

- 9)  The specification is objected to by the Examiner.
- 10)  The drawing(s) filed on \_\_\_\_\_ is/are: a)  accepted or b)  objected to by the Examiner.  
 Applicant may not request that any objection to the drawing(s) be held in abeyance. See 37 CFR 1.85(a).  
 Replacement drawing sheet(s) including the correction is required if the drawing(s) is objected to. See 37 CFR 1.121(d).
- 11)  The oath or declaration is objected to by the Examiner. Note the attached Office Action or form PTO-152.

**Priority under 35 U.S.C. §§ 119 and 120**

- 12)  Acknowledgment is made of a claim for foreign priority under 35 U.S.C. § 119(a)-(d) or (f).
  - a)  All    b)  Some \*    c)  None of:
    - 1.  Certified copies of the priority documents have been received.
    - 2.  Certified copies of the priority documents have been received in Application No. \_\_\_\_\_.
    - 3.  Copies of the certified copies of the priority documents have been received in this National Stage application from the International Bureau (PCT Rule 17.2(a)).
  - \* See the attached detailed Office action for a list of the certified copies not received.
- 13)  Acknowledgment is made of a claim for domestic priority under 35 U.S.C. § 119(e) (to a provisional application) since a specific reference was included in the first sentence of the specification or in an Application Data Sheet. 37 CFR 1.78.
  - a)  The translation of the foreign language provisional application has been received.
- 14)  Acknowledgment is made of a claim for domestic priority under 35 U.S.C. §§ 120 and/or 121 since a specific reference was included in the first sentence of the specification or in an Application Data Sheet. 37 CFR 1.78.

**Attachment(s)**

- 1)  Notice of References Cited (PTO-892)
- 2)  Notice of Draftsperson's Patent Drawing Review (PTO-948)
- 3)  Information Disclosure Statement(s) (PTO-1449) Paper No(s) \_\_\_\_\_
- 4)  Interview Summary (PTO-413) Paper No(s). \_\_\_\_\_
- 5)  Notice of Informal Patent Application (PTO-152)
- 6)  Other: \_\_\_\_\_

**DETAILED ACTION**

***Response to Amendment***

In response to the Request for Continuing Examination (RCE) filed October 27, 2003 in which the applicant has amended claims 37 and 38, and claims 37-62 are pending in this office action.

***Claim Rejections - 35 USC § 102***

1. The following is a quotation of the appropriate paragraphs of 35 U.S.C. 102 that form the basis for the rejections under this section made in this Office action:

A person shall be entitled to a patent unless –

(e) the invention was described in a patent granted on an application for patent by another filed in the United States before the invention thereof by the applicant for patent, or on an international application by another who has fulfilled the requirements of paragraphs (1), (2), and (4) of section 371(c) of this title before the invention thereof by the applicant for patent.

The changes made to 35 U.S.C. 102(e) by the American Inventors Protection Act of 1999 (AIPA) and the Intellectual Property and High Technology Technical Amendments Act of 2002 do not apply when the reference is a U.S. patent resulting directly or indirectly from an international application filed before November 29, 2000. Therefore, the prior art date of the reference is determined under 35 U.S.C. 102(e) prior to the amendment by the AIPA (pre-AIPA 35 U.S.C. 102(e)).

2. Claims 37 and 38 are rejected under 35 U.S.C. 102(e) as being anticipated by Roseman '984.

3. Roseman discloses accessing via a remote terminal, a game site on a global computer network (internet) connected to the remote terminal, providing personal identification

information to the gaming site, selecting a game of chance for remote play, placing a wager for playing the selected game, and receiving randomly-generated text or graphical outcome data at the remote terminal for the selected game (game server), in which the examiner interprets the selected game to be the game server being a game machine itself on a gaming site having a plurality of games, and the outcome data being generated by the gaming machine (gaming server) and relayed to the gaming site as recited in claims 37 and 38.

*Claim Rejections - 35 USC § 103*

4. The following is a quotation of 35 U.S.C. 103(a) which forms the basis for all obviousness rejections set forth in this Office action:

(a) A patent may not be obtained though the invention is not identically disclosed or described as set forth in section 102 of this title, if the differences between the subject matter sought to be patented and the prior art are such that the subject matter as a whole would have been obvious at the time the invention was made to a person having ordinary skill in the art to which said subject matter pertains. Patentability shall not be negated by the manner in which the invention was made.

5. Claims 37-62 are rejected under 35 U.S.C. 103(a) as being unpatentable over Walker '016 in view of Wiltshire '602.

6. Walker discloses a communication link between the remote terminal and a gaming site, the gaming site in communication with a gaming server for outcome data from gaming machines located at a gaming establishment, selecting a gaming machine, making a wager to play the selected gaming machine, receiving outcome data including game outcome at the remote terminal resulting from play of the gaming machine (column 2, lines 51-65), generating a payout, a microprocessor, and the memory connected to the microprocessor as recited in claims 37-39, 52, and 62; the outcome data having information identifying the value of the payout and simulate

a display of the game outcome at the remote location (column 5, lines 33-37) as recited in claims 40 and 59; the outcome data to simulate a display of the game outcome on the remote terminal (column 5, lines 33-37) as recited in claim 41; the selected gaming machine is a slot machine wherein the outcome data includes reel position (column 5, lines 33-37) as recited in claims 42, 48, 53, and 60; the selected gaming machine is a video poker machine including a display for displaying a poker hand (column 5, lines 33-37) as recited in claims 43 and 58; the receiving outcome data includes receiving outcome data from a plurality of gaming machine form remote play (column 6, lines 45-56) as recited in claim 44; the outcome data includes a gaming machine identifier and gaming machine type (figure 5 and column 6, lines 31-44) as recited in claim 45-46 and 55-56; the outcome data including receiving player preferences (column 6, lines 8-30) as recited in claims 47 and 57; a player identifier and transmitting the player identifier for identification of the player (column 6, lines 8-30) as recited in claims 49 and 61.

Walker does not expressly disclose the communication link between the remote terminal and a gaming site on a global computer network (Internet) and receiving text or graphical outcome data at the remote terminal for the selected game as recited in claims 37-39, 52, and 62; the game outcome results from the server initiating game play on the selected gaming machine as recited in claim 50; the outcome results from the manual game play on the selected gaming machine as recited in claim 51; receiving information includes receiving information selecting at least two plurality of local gaming machines for remote play as recited in claim 54.

Wiltshire teaches a communication link between the remote terminal and a gaming site on a global computer network (column 5, lines 31-44) and receiving text or graphical outcome data at the remote terminal from the selected game (column 7, lines 7-45), the game outcome



resulting from the server initiating game play on the selected gaming machine (column 8, lines 42-65), the outcome results from the manual game play on the selected gaming machine, and receiving information includes receiving information selecting at least two plurality of local gaming machines for remote play (column 8, lines 42-65). By having a communication link between the remote terminal and a gaming site on a global computer network (Internet) and receiving text or graphical outcome data at the remote terminal for the selected game, one of ordinary skill in the art would allow game players to participate in different casino type games from a secure and tamper proof computer gaming system.

Therefore, it would have been obvious to one of ordinary skill in the art at the time of the invention was made to modify Walker to include a communication link between the remote terminal and a gaming site on a global computer network and receiving text or graphical outcome data at the remote terminal for the selected game, the game outcome resulting from the server initiating game play on the selected gaming machine, the outcome results from the manual game play on the selected gaming machine, and receiving information includes receiving information selecting at least two plurality of local gaming machines for remote play as taught by Wiltshire. To do so would allow game players to participate in different casino type games from a secure and tamper proof computer gaming system

### *Conclusion*

7. The prior art made of record and not relied upon is considered pertinent to applicant's disclosure.

Falciglia `849, Soltesz `069, Robb `580, Schneier `557, and Paravia all disclose different types of gaming system played on a global computer network.

Any inquiry concerning this communication or earlier communications from the examiner should be directed to Alex P. Rada whose telephone number is 703-308-7135. The examiner can normally be reached on Monday - Friday, 08:00-16:00.

If attempts to reach the examiner by telephone are unsuccessful, the examiner's supervisor, Tom Hughes can be reached on 703-308-1806. The fax phone number for the organization where this application or proceeding is assigned is 703-872-9306.

Any inquiry of a general nature or relating to the status of this application or proceeding should be directed to the receptionist whose telephone number is 703-308-1148.

AB2  
Apr

  
S. THOMAS HUGHES  
SUPERVISORY PATENT EXAMINER  
TECHNOLOGY CENTER 3700

<b>Notice of References Cited</b>	Application/Control No. 09/688,501	Applicant(s)/Patent Under Reexamination JOSHI, SHRIDHAR P.	
	Examiner Alex P. Rada	Art Unit 3714	Page 1 of 1

**U.S. PATENT DOCUMENTS**

*	Document Number Country Code-Number-Kind Code	Date MM-YYYY	Name	Classification
*	A US-6,012,984	01-2000	Roseman, Stuart	463/42
*	B US-6,409,602	06-2002	Wiltshire et al.	463/42
*	C US-6,001,016	12-1999	Walker et al.	463/42
	D US-6,508,710	01-2003	Paravia et al.	463/42
	E US-6,264,557	07-2001	Schneier et al.	463/29
	F US-5,830,069	11-1998	Soltesz et al.	463/42
	G US-5,971,849	10-1999	Falciglia, Sal	463/16
	H US-6,488,580	12-2002	Robb, Robert W.	463/23
	I US-			
	J US-			
	K US-			
	L US-			
	M US-			

**FOREIGN PATENT DOCUMENTS**

*	Document Number Country Code-Number-Kind Code	Date MM-YYYY	Country	Name	Classification
	N				
	O				
	P				
	Q				
	R				
	S				
	T				

**NON-PATENT DOCUMENTS**

*	Include as applicable: Author, Title Date, Publisher, Edition or Volume, Pertinent Pages)
	U
	V
	W
	X

\*A copy of this reference is not being furnished with this Office action. (See MPEP § 707.05(a).)  
Dates in MM-YYYY format are publication dates. Classifications may be US or foreign.

54

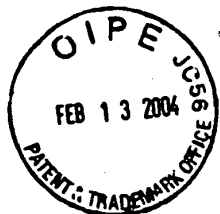

*Examination 3714  
2-23-04  
14/*

IN THE UNITED STATES PATENT AND TRADEMARK OFFICE

RECEIVED  
FEB 19 2004  
TECHNOLOGY CENTER R5780

Application No. : 09/688,501  
 Applicants : Shridhar P. Joshi  
 Filed : October 16, 2000  
 Title : Method Of Transferring Gaming Data On A Global Computer Network  
 TC/A.U. : 3714  
 Examiner : Alex P. Rada  
 Docket No. : 47079-00077  
 Customer No. : 30223

Commissioner for Patents  
 P.O. Box 1450  
 Alexandria, VA 22313-1450

**CERTIFICATE OF MAILING**  
 I hereby certify that this correspondence is being deposited with the United States Postal Service as first class mail, postage prepaid, in an envelope addressed to the Commissioner for Patents, P.O. Box 1450, Alexandria, VA 22313-1450, on February 10, 2004.  
 Signature: *Deborah Ricks*  
 Deborah Ricks

**SECOND INFORMATION DISCLOSURE  
 STATEMENT UNDER 37 C.F.R. §§ 1.97 AND 1.98**

Dear Sir:

In compliance with the duty of disclosure under 37 C.F.R. § 1.56, it is respectfully requested that this Second Information Disclosure Statement be entered, and the references listed on enclosed Form PTO-1449 be considered by the Examiner and made of record. In accordance with 37 C.F.R. § 1.98(d), copies of the listed references are enclosed.

In accordance with 37 C.F.R. §§ 1.97(g) and (h), this Second Information Disclosure Statement is not to be construed as a representation that a search has been made, or an admission that the information disclosed is, or is considered to be, prior art with respect to the present application or material to patentability, as defined in 37 C.F.R. § 1.56.

In accordance with 37 C.F.R. § 1.97(e)(1), attorney for the Applicant hereby certifies that each item of information contained in this Second Information Disclosure Statement was cited in a communication from a foreign patent office in a counterpart foreign application not more than three months prior to the filing of this Second Information Disclosure Statement, as evidenced by the enclosed Search Report published December 19, 2003, for European Application No. EP 01 40 2524.

This Second Information Disclosure Statement is being filed after the mailing date of the first Office Action, but before the mailing date of either a final Office Action under 37 C.F.R. § 1.113 or a Notice of Allowance under 37 C.F.R. § 1.311. In view of the preceding certification, no fee is believed to be due. Should any fee be deemed necessary (except payment of the issue fee), however, the Commissioner is hereby authorized to charge any additional fees which may be required, or credit any overpayment, to Deposit Account No. 10-0447 (47079-00077USPT). A duplicate copy of this Statement is enclosed for that purpose.

Respectfully submitted,

Date: February 10, 2004



---

Sorinel Cimpoes  
Reg. No. 48,311

**Jenkins & Gilchrist, P.C.**  
225 West Washington Street, Suite 2600  
Chicago, Illinois 60606-3418  
Attorneys for Applicant  
(312) 425-8542

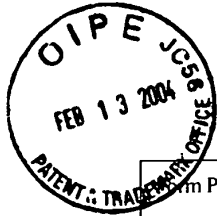

Form PTO-1449 (modified)	Application No.: 09/688,501
<b>LIST OF ART CITED BY APPLICANT</b>	Filing Date: October 16, 2000
	First Named Inventor: Shridhar P. Joshi
	Group Art Unit: 3714
	Examiner: Alex P. Rada
	Attorney Docket No.: 47079-00077USPT
Sheet 1 of 1	

**U.S. PATENT DOCUMENTS**

Examiner Initial	Ref.	Document Number	Date	Name	Class	Sub-Class	Filing Date (if Application)
	A7						

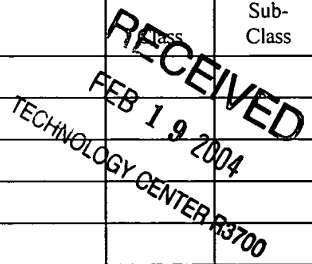

**FOREIGN PATENT DOCUMENTS**

Examiner Initial	Ref.	Document Number	Date	Country	Class	Sub-Class	Translation Yes/No
	B1	EP 0 843 272 A1	05/20/1998	Europe	G06F	19/00	N/A
	B2	EP 0 829 834 A2	03/18/1998	Europe	G07F	17/32	N/A
	B3						
	B4						
	B5						
	B6						
	B7						
	B8						

**OTHER DOCUMENTS (including author, title, date, pertinent pages, etc.)**

Examiner Initial	Ref.	Document Information

**EXAMINER**

**DATE CONSIDERED**

\*Examiner: Initial if citations considered, whether or not citation is in conformance with MPEP 609; draw line through citation if not in conformance and not considered. Include copy of this form with next communication to Applicant.

CHICAGO 278143v1 47079-00077



Europäisches Patentamt  
European Patent Office  
Office européen des brevets



(11) EP 0 843 272 A1

(12) **EUROPEAN PATENT APPLICATION**  
published in accordance with Art. 158(3) EPC

(43) Date of publication:  
20.05.1998 Bulletin 1998/21

(51) Int. Cl.<sup>6</sup>: G06F 19/00  
// G06F161:00

(21) Application number: 95937249.1

(86) International application number:  
PCT/RU95/00241

(22) Date of filing: 10.11.1995

(87) International publication number:  
WO 97/05557 (13.02.1997 Gazette 1997/08)

(84) Designated Contracting States:  
AT BE CH DE DK ES FR GB GR IE IT LI LU MC NL  
PT SE

(72) Inventor:  
Lvov, Denis Ernestovich  
St. Petersburg, 195067 (RU)

(30) Priority: 27.07.1995 RU 95112888  
27.07.1995 RU 95112823

(74) Representative: Kador & Partner  
Comellusstrasse 15  
80469 München (DE)

(71) Applicant:  
Lvov, Denis Ernestovich  
St. Petersburg, 195067 (RU)

(54) **ELECTRONIC GAME SYSTEM, A METHOD OF MANAGING AND REGULATING SAID SYSTEM**

(57) The electronic gaming system (ESG) and the method of system control and adjustment relates to computerized gaming and service systems that implement a computerized programmable control and can be used in local and global networks to establish casinos.

The EGS consists of a central computer station (1) (CCS), peripheral computer stations (25) (PCS) with communications provided between them, a data transmission network (32) (DTN). The CCS consists of a players registration system (3), a game accounts managing system (4), an information tabulating, scoring and searching system (5), a system for recording gaming situations (6), a system for scoring players by the results of the game (7), a wagering and betting system (8), an executive gaming system (9), a data exchange system (10). The CCS also includes an electronic payments system (11), an information protection system (12), a secure communications system (13), a game selection system (14), a mailing system (15). The DTN provides interaction of PCSs with the CCS in an arbitrary combination of PCS types and comprises a communications station (20) and a data transmission network (32).

The method of control and adjustment of said system provides the following actions: a player is identified at his registration by a set of key attributes that are encoded and sent to the central computer station (CCS) where they are compared to the individual information of the protection system. The information is individually encoded and sent as a message to the administrator and the subjects of the system that are present. The

player selects a starting composition of his playing team, selects and indicates the selection criteria, after which the EGS is automatically adjusted. The player is connected to one or more games and is scored by each of them. If the set of key attributes does not coincide, a registration failure is logged in the electronic protocol. The number of registration attempts is limited, and, when exceeded, a warning of an EGS intrusion is generated, and the player's accounts are blocked.

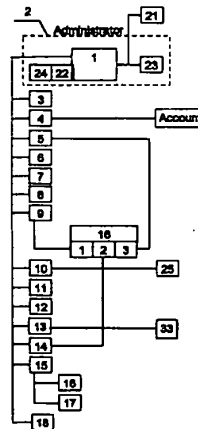

FIG. 1

EP 0 843 272 A1

## Description

## FIELD OF THE INVENTION.

5 The invention relates to electronic games and service systems used in local and global networks for establishing casinos, in administrative and production systems, as well as in stock exchange systems and other communications and marketing systems requiring their parts to interact.

## DESCRIPTION OF THE PRIOR ART

10 The patent "Multi-player type video game playing system" (EP, A1, 0387862, 19.09.90, A63F9/22) is known that describes a playing system consisting of a cylinder-shaped screen with several radially arranged projectors. Each of the projectors is directed at a specific section of the screen. Several player's operating sections are arranged radially toward the screen. The sections, however, can be locally arranged around only one processor and do not provide for connect-  
15 ing service companies to the system as its subjects.

Gaming sets of equipment for gaming centers are known (LP, B, 3-70993, 11.11.91 and JP, B, 3-70994, 11.11.91) that are designed for playing on several group-forming gaming machines with a possibility of settling game accounts for games with several players. They, however, do not permit establishing of a protected network that is not limited by distance and that provides for a possibility of serving several companies and/or players belonging to the system (possibility  
20 of money transactions included) at a diversity of the game basis for wagering, betting and other game events.

Electronic settlement of accounts via networks that provide communications with financial institutions is known, for instance, "Apparatus and method for providing credit for operating a gaming machine" (US, A, 5038022, 06.08.91) and "Installation permettant de participer à distance et en direct à des jeux de casino" (FR, A1, 2666672, 13.03.92). They, however, do not permit establishing of a geographically unlimited gaming system consisting of a plurality of subjects  
25 that envisages a simultaneous modeling of the gaming situation and settling the accounts by the results of the game through a financial institution.

Patents "A communication terminal used as a game machine" (EP, A2, 0477775, 04.01.92) and "Game of skill or chance playable by several participants remote from each other in conjunction with a common event" (US, A, 5083800, 28.01.92) are known that use telephone lines and terminals. The authors, however, did not envisage establishing of a  
30 protected network with service possibilities, including that of money transactions, on a broad gaming basis with various combinations of playing teams.

The patent "Game playing system" (US, A, 4958835, 25.09.90, A63F9/22) is known that describes a system with a plurality of gaming machines interconnected by a communications channel that enables them to exchange data using an identification code for each machine. Upon each reception of data the identifying device of the system checks  
35 whether the data belongs to the transmitting machine. In case the data cannot be identified, the game account is reset and incriminated, and the real account owner is searched for by addressing gaming machines of the system. This system, however, can completely upset a player's game in case of system failure which may entail a money loss on player's bank account and decreases the system reliability.

The patent "Game scoring method" (US, A, 4900027, 19.10.88, G06F15/44) is known describing a computer-based scoring method in which each player is assigned an identifying digital number entered in conjunction with "WE" or "THEY" key depression, thereafter digital numbers indicating scores earned are entered in conjunction with "WE" or "THEY" key. At the end of a game the computer displays a total score for each individual player together with his identifying number. However, it heavily narrows the possibility of selecting a desirable composition of players for a given gaming situation and provides no privacy of players' accounts. The patent "Method of lookahead pipeline for processing  
45 object records in a video system" (US, A, 4894774, 16.01.90, G06F15/44) is known. It describes a method that permits to search an associated database list that contains information on all the objects meeting the preset criteria. An associated list of criteria on this or that object is compiled by which the object is searched for among those available, its position and dimensions on the display are specified together with the address of stored graphic data and the address of the communications index that specifies the address of the next entry in the associated list. After that the list is consecutively searched for those entries that satisfy the preset criteria. This method, however, provides no opportunity for a  
50 player to select a team that meets his criteria for a given gaming situation and to join the situation together with the desired team of players.

A computerized gaming system for playing poker, described in Patent US, A, 4926327, 15.05.90, G06F15/44, is the closest by its engineering essence to the suggested electronic gaming system (EGS). The former consists of a central  
55 computer unit (CCU) and a group of individual player consoles (IPC) interconnected with the CCU. The CCU is equipped with means enabling all players to initiate a set of wagers, a circuit to initiate all poker game events with a simultaneous data exchange, a circuit to evaluate each player's cards and determine the order of finish of the players, a circuit to divide the total amount wagered. Each IPC is equipped with a processor, a circuit to receive and display the



cards assigned to an individual player, a circuit permitting each player to respond to the game events initiated by the processor, a circuit to receive and display wagering data. The system enables a plurality of players to simultaneously wager within the initiation time period equal to the period a player is permitted to wager. The system provides for a multivariant poker game that complies with the parameters set either automatically by the system or manually by the players. It also performs a final scoring for each player after the game is finished. The system permits to install a plurality of IPCs within a local territory, enables each player to monitor game events, and restricts the surrounding people from observing the game results on the IPC display through use of a funnel-shaped screen. The system can be used in casinos. This computer system, however, can offer players only one type of gaming situation and is limited in territory by the possibilities of a given local network. Besides, it provides no opportunity for establishing a protected network that is unlimited by its territory and can serve all its subjects, both players and companies that require a broad gaming basis enabling them to wager in any combinations, perform money transactions through financial institution once the game is over, etc.

A computerized statistical football game described in patent US, A, 4918603, 17.04.90, G06F15/44 can serve as the closest example of the suggested method of system control and adjustment by its engineering essence. The game has means for setting up individual football franchises, for selecting starting player rosters, for scoring performances for each football player. The invention belongs to gaming systems, being able to control gaming situations depending on variations in football team composition and the process of selection and exchange of football players, as well as the process of scoring performances for each football player after they were exchanged between the teams. This method, however, envisages no possibility for a gaming system user to compose a football team with a guaranteed participation of only those subjects that were identified and checked for their affiliation to the system. Besides, it cannot provide privacy of information on the gaming situation within a selected game and on its final results.

#### DISCLOSURE OF THE INVENTION

The invention solves the problem of creating an electronic gaming system that provides a broad variety of gaming situations and helps acquire habits of solving logical and strategic problems, betting and forecasting the results of various gaming situations in interaction with other players, for instance, in totalisator or while playing roulette, as well as wagering in gambling combination games the player participates in, like card games, checkers, chess, etc. The system meets the requirement that a player be able to join a gaming situation any time of day or night disregarding the working hours of an establishment, casino for instance, to play several games at a time or to combine playing with other activities without the necessity to leave the premises comfortable to the user and go someplace else. The possibility of betting real money through player's bank accounts that guarantees confidentiality of his wins, accuracy and verifiability of settlements as well as player's personal safety combined with an opportunity to communicate stimulates him to join a game. All the above is realized in a virtual computer world with participation of real players or groups of players selected by the user who can assess them on the basis of the available information. At the same time all the players remain personally unknown to the participants of the gaming situation.

The basic problem of the invention is also solved by devising a method of controlling and adjusting such systems as described above. The operation of computerized gaming systems, for instance, of casino type, requires integration of functionally similar gaming and servicing situations necessary and/or desirable for a player to join such a system. Moreover, it is required that a specific gaming situation be joined only by those of all the system subjects that are registered in the system and have had their honesty checked. The system must prevent a possibility of an intended intrusion and ensure confidentiality of all gaming events and settlements while providing a high invariance level of offered gaming situations and their combinations.

The electronic gaming system consists of a central computer station (CCS), peripheral computer stations (PCS) and a data transmission network (DTN) to interconnect them.

The CCS includes a computer of the administrator and is equipped with the following systems: a players registration system, a game accounts managing system, an information tabulating, storing and searching system, a system for recording gaming situations, a system for final scoring by the results of the game, a wagering and betting system, an executive gaming system, a data exchange system.

The players registration system is designed to register all new subjects who join the system, those already logged on, or those who leave the system. Thus, the system ensures control over a certain restricted group of included subjects.

The game accounts managing system controls the players' game accounts, executes settlements between the players and the CCS and performs operations on their bank accounts.

The information tabulating, storing and searching system serves to accumulate and process the information on players, gaming situations, selection criteria, etc. and keeps special records of communications sessions that permit to check the validity and correctness of administrator actions and the reliability of system protection.

The system for recording gaming situations keeps records on each of the player-initiated games and stores the cur-

rent gaming situations to permit their restoration in case of a communications failure. Thus, the information in the system is preserved even in case of emergency, enabling a player to check the validity and correctness of settlements.

The wagering and betting system provides a possibility to bet and wager prior to the beginning of a game.

5 The executive gaming system performs a direct control over the blocks that realize the gaming process, provides information input and output as well as other actions necessary to play a game.

Unlike the state-of-the-art central gaming computers, the CCS comprises an electronic payments system, an information protection system, a secure communications system, a game selection system and a mailing system.

The executive gaming system realizes various gaming situations on the basis of the EGS database.

10 The secure communications system provides personal communications of PCS with the CCS administrator or with other PCSs by means of electronic communications.

The communications can also be organized between any two or more arbitrarily formed PCS groups.

The game selection system includes a database on all the gaming situations and permits to select a game by any preset (indicated) criterion, to join the selection, to participate in several games at a time by switching over from one to another.

15 The electronic payments system provides information exchange with financial institutions, such as banks, and executes electronic payments by means of telecommunications.

The information protection system protects personal, financial and general network information used by the players against an unauthorized intrusion, as well as demarcation and redistribution of information and information access among the EGS subjects.

20 The secure communications system provides a direct real-time interactive communications between the system subjects, as well as between a player and the administrator or between groups of players. The system enables a player to overcome the time restriction imposed by working hours of a casino since the latter actually turns into an electronic gaming system.

25 The CCS and PCSs include mailing systems providing a personal electronic mail for PCSs and/or topical electronic billboards, reference systems and a data exchange system. The reference system supplies information on the players that are present in the EGS, a game rating of each of the potential players and offers an opportunity to select a partner by any of the preset criteria.

30 The mailing system is designed to provide an exchange of personal messages between the users and other electronic mail services and to update the electronic billboards. Players' personal messages are transmitted in the form of secure packages and can be processed by addressees both in CCS-connected or CCS-disconnected status, since they require no immediate reaction.

The personal E-mail system provides individual correspondence among players, between players and the administrator or other system subjects within the EGS limits. The system also provides topically-grouped in-system electronic billboards. Such a structure ensures a protected information exchange for the subjects included into the system.

35 The data exchange system provides a protected data exchange between the CCS and PCSs.

The reference system enables a user to easily find the necessary information on the gaming system, thus preventing potential errors on his part that could cause a loss of information or disclosure of his personality. The reference system assists in and simplifies the use of the gaming system.

40 The PCS comprises modems and computers of the players and those of the financial PCSs. The financial PCSs have their own bank accounts. Optionally, they can be equipped with means of radio communications, modems, network and/or radio modems, desktop and/or laptop computers. The modem and computers comprised in a PCS can be stand-alone and/or integrated into a LAN with a terminal. Operation of the CCS in the data exchange network permits it to interact with any arbitrary combination of PCS types. The data transmission network consists of a communications station interacting with both radio and network modems.

45 So, the EGS provides administration, data exchange and execution of gaming processes while ensuring security, privacy and a broad variety of games and services. Moreover, it monitors the players' accounts and will never allow a player to lose more than is deposited on his bank account.

The method of system control and adjustment consists of players registration, selection of a playing team starting composition and scoring each player in a given game.

50 The distinction of the suggested method lies in the fact that a player is identified at his registration by a set of key attributes that are transmitted to the CCS protection system in an encoded form. The information supplied by a player is individually encoded and sent to the administrator as well as the present (installed) subjects of the EGS. Having registered, the player selects a starting composition of teams (groups). To do so, he gets acquainted with the information search system, selects and directly indicates the required criteria, and passes them on to the CCS which performs an automatic adjustment of the EGS. Then the player joins one or more games selected from the game database list. The player is scored by the results of each game he participates in. In case the set of attributes entered by a player does not coincide with the one stored, a registration failure is registered in the electronic protocol and the administrator is informed thereof. The number of registration attempts is limited, and when it is exceeded, the EGS is warned of an intru-

sion. In this case the bank and/or other player's accounts are blocked. After the registration the gaming image of the player can be modified on his request in accordance with the suggested common rules. A player can monitor any of the selected games by switching the games over on his display and can interactively influence the regime of the games installed in the EGS.

5 With games installed, a player can select any information in the process of the game and send it to any subject included into the EGS.

In accordance with the above method, the confidentiality of data transmission, the security of the system and the privacy of bank accounts can be observed by players and the system-included subjects that provide services only when the EGS is comprehensively controlled and adjusted at all stages of its subjects interaction. The above factors are also  
10 provided through use of an information encoding system with individual for each player encoding keys in all of his communications sessions with casino programs.

The suggested electronic gaming system permits to establish an unlimited-by-territory closed-for-public network with confidential services open to all of its included subjects, both players and companies. The system offers a broad gaming basis and provides for money transactions by the results of one or several selected games through players'  
15 bank accounts.

The suggested method prevents an unauthorized access to the system and guarantees privacy of all actions undertaken in the process of or after the gaming situations that are formulated in accordance with the player's requests together with the team members selected by him.

## 20 BRIEF DESCRIPTION OF THE DRAWINGS

The invention is illustrated by drawings that show:

25 Fig.1 - structure of the central computer station;

Fig.2 - structure of possible types of peripheral computer stations;

Fig.2a - option 1: a single peripheral computer station;

30 Fig.2b - option 2: a peripheral computer station of financial companies;

Fig.2c - option 3: a mobile peripheral computer station using radio communications;

35 Fig.2d - option 4: a network peripheral computer station;

Fig.3 - structure of the data transmission network;

Fig.4 - EGS interaction diagram;

40 Fig.5 - displayed list of actions for entering the system;

Fig.6 - displayed structured information from the game selection database;

45 Fig.7 - displayed structured information for selecting players;

Fig.8 - displayed rating of players;

Fig.9 - table for selecting players by preset criteria;

50 Fig.10 - displayed scoring table and account information;

Fig.11 - diagram of the sequence of system-controlling actions;

55 Fig.12 - diagram of the players registration mode;

Fig.13 - diagram of the starting players composition selection mode;

Fig.14 - diagram of the game joining and monitoring mode;

Fig.15 - diagram of player account management and settlements;

Fig.16 - displayed "images" of players.

5 INVENTION EMBODIMENT OPTIONS

The electronic gaming system consists of a CCS (1) that comprises a modem device (21), a server (22), a computer of the administrator (23) and a terminal (24), all operating as a single administrative system (2), see Fig. 1.

10 The CCS structure is a combination of soft- and hardware that stores, collects and controls the information of a computerized gaming system, for instance, of casino type.

The CCS consists of a players registration system (3), a game accounts managing system (4), an information tabulating, storing and searching system (5), a system for recording gaming situations (6), a system for final scoring by the results of the game (7), a wagering and betting system (8), an executive gaming system (9), a data exchange system (10), see Fig.1, 2a-d.

15 The EGS is equipped with peripheral computer stations (PCS) (25) that comprise a system for admitting players (26) to the CCS and a gaming interface system (27), see Fig.2a-d.

Unlike the state-of-the-art central gaming computers, the CCS (1) also comprises an electronic payments system (11), an information protection system (12), a secure communications system (13), a game selection system (14), an executive gaming system (9). The CCS realizes the gaming situations from the database (16') of the executive gaming system (9), see Fig.1. The interaction between the CCS (1) and a PCS (25) is carried out through a data transmission network (32), see Fig.4, comprising a communications station (20) that can communicate both with radio modems (28'), see Fig.2c, and network modems (28), see Fig.2a,b,d. The EGS can also feature, for instance, mailing systems (15), see Fig.1 and 2a-d, that are included into the CCS (1) and PCSs (25).

25 The EGS can, for instance, have either a single a secure communications system (13) or a secure communications system combined with a mailing system (15). The a secure communications system provides electronic communications of a PCS with the administrator computer (23) at the CCS (1), or communications of PCSs (25) among themselves, see Fig.4. The a secure communications system (13) can provide communications of any two or more arbitrarily formed groups (29) of PCSs (25), see Fig.4.

30 The game selection system (14) comprises a database (16'') that describes all types of gaming situations and permits selection of any of them, see Fig.6.

The information tabulating, storing and searching system includes a database (16''') that describes the composition of players and their rating, and permits to select players by any preset criterion, see Fig.8, 9. The PCS includes computers (30) or a computer network (31) and modems (28) of both players and bank and/or other deposit accounts, see Fig.2a-d. The CCS consists of a terminal (24) and a server (22) of the administrator (2), connected to a modem device (21), see Fig.1. The CCS (1) provides interaction of PCSs (25) in any arbitrary combination through the data transmitting network (32). The PCS (25) includes a modem (28) and computers (30, 31) that can be both desk- and laptop. The computers included into the PCS (25) can be either stand-alone, see Fig.2a, or connected to a LAN, see Fig.2d, having a terminal and a modem (28), see Fig.2d.

40 All the systems operate in an interactive mode and are based, by the general classification, on methods of comparison, classification and identification of images (MCCII) that treat comparison as a measuring operation performed by a measuring and computing complex (MCC). The MCC has an hierarchic structure since each system solves its own problem, independently classifies a specific action with this or that type of problem, and interactively passes its decision to an appropriate system. The EGS adequately identifies and organizes the operation of the whole system performing the role of an MCC using MCCII, collects and processes the data obtained as a result of a complex examination of the situation. When necessary, the main gaming functions can be set by a player during a game, or by the administrator in the administrative mode of system operation. A model formulated in terms of fuzzy logic is applied to use the database. Using the rules for composing fuzzy relationships, a diagnostic decision for each data set is worked out that assumes the form of an affirmation, negation or question on further gaming process when applied to the most suitable variant. Versions of such a system are known from publications, for instance,

50

A.С.Клешеев, М.Ю.Черняховская. Системы представления

55

проблемно-ориентированных знаний [Systems for problem-oriented knowledge representation]. Известия АН СССР, 1982, N 5, сс.43-63.

The database is represented by a set of data organized by the SDSA (structured description of subject area) principle with each set physically located as a separate system on the disk

5

(Н.Т.Рустамов, Г.Т.Ибрагимов. Описание инструментальных средств для построения советующих распознающих систем [Description of tools

10

for constructing advising identification systems]. УЭНПО "Кибернетика", АН СССР, Ташкент, 1991 г.

20

Formal language means are used for administrative-type information systems, for instance "DESKTOP SYSTEM"

25

(С.П.Ботуз. Методы и средства отображения многомерных параметрических зависимостей [Methods and means for representation of multi-dimensional parametric dependencies]. Сб.науч.трудов:

30

Информационные технологии искусственного интеллекта. М. ГосИФТП, 1994 г. УДК 681.51/513.2).

35

To realize the suggested method of system control and adjustment, each player, who wishes to participate in the system, performs the following operations from his peripheral computer station (PCS) (25) through a telephone line: activates (36) the PCS, establishes connection (37) with the central computer station CCS (1), starts the player registration system (38), see Fig.11. Each player has a bank and game deposit accounts (34) included into the EGS, as well as his permanent and operational identifying attributes (code, encoding key, password, pseudonym, gaming image) logged in the system. In order to join the system, a player must have a computer connected through a modem to a telephone line and a special software. A physical connection with the GCS, followed by an automatic connection through the telephone line to the CCS (1), is established by registration, see Fig. 11. If the registration is successful (39), the GCS monitor is activated (40) and interaction with the working block of the system (41) becomes possible. The player receives the necessary information (42) from the reference system, selects a game he is interested in (43) and controls the gaming process (44). All the financial settlements resulting from the game are performed by the system (45). In case of a registration failure (46) the PCS is blocked (47), and the system provides an opportunity to personally address (48) the administrator by connecting the player with the administrator, see Fig.11. At this point the player's registration session is stopped.

50

To accomplish registration, see Fig.12, a player activates the registration system (50) by clicking a corresponding item on the PCS-displayed menu and enters, upon request, his identifying attributes (51), i.e. his code, password and pseudonym, in sequence. The registration system compares the received information with the identifying attributes stored in the CCS database. If they coincide (52), a successful registration (53) is logged in the electronic protocol, player's business cards are sent to his constant partners and the administrator (54), and the player is connected to the working block to perform all further actions. Thus, the registration procedure is successfully completed (55). A special system for encoding information with an individual for each player encoding key is used to provide security and privacy of communications between a player and the casino.

55

If the identifying attributes do not coincide (56) with those stored in the CCS database, the attempt is logged in the electronic protocol as a registration failure (57) and is compared with the number of allowed attempts (58). If the number of attempts is exhausted (59), the player is urgently connected to the administrator (60) for a dialog. After the dialog the CCS sends a request "is the personality of the player identified?" (58). If the answer is "yes" (61), a successful registration of the player is automatically logged in the protocol (53), and he is connected to the working block (41). If the answer is "no" (62), an intrusion attempt is logged (63), the player's account is blocked (64) to prevent theft of money. The registration is aborted (65).

In case the number of registration attempts is not exhausted (66) the player enters his identification attributes once again (51). If the registration was accomplished successfully, the player can use the registration system for changing his identifying attributes - pseudonym, password, see Fig.5, and his gaming image, see Fig.16. The player's pseudonym and gaming image can be changed in strict compliance with the preset rules which protects other players against fraud. The player's password can be changed at his will by selecting an arbitrary combination of numerals and letters, both Latin and Cyrillic, or any other characters offered by the computer keyboard.

The registration system is also actuated to log a player's temporary exit from the casino or his final quitting of the system. In such cases appropriate mandatory entries are logged in the protocol and the CCS database. Any data exchange in the EGS is performed through information protection means (12) that encode and decode the information in players' computers.

After a player is connected to the working block (41) in the protected display mode, he can actuate any mode of this block and switch over between several modes. A player can switch over to information or gaming mode, start one or several games, or start selecting players for his team.

In the players searching mode the user actuates the search system (67), specifies his criteria (68) and receives a request "are needed candidatures available?" (69). If the answer is "yes", he can select his partners from the list (70). Then the player's business cards are sent to the selected persons (71), and the partners enter a dialog exchange (72) to specify the criterion of the initiator, for instance, what gaming table the initiator would like to join, see Fig.7, or what players by pseudonym, gaming image or rating he is willing to invite, see Fig.9. Then the system requests "do all partners agree?" (73). If the answer is "yes", the team is considered to be formed (74). If the answer is "no", the system requests "abort players selection?" (75). If the answer is "yes", the selection process is stopped. If the answer is "no", the system repeats its request "do all partners agree?" (73). The required rating of players can be either assigned by the initiator himself or can be chosen by him from the players rating table, see Fig.8, offered by the information system (42). The rating is selected by a probability percent of partner's wins in a specific type game. If the EGS contains games with the specified criteria, the system offers the list of games and the game selection process starts (77), see Fig.14. Prior to the start the player selects his partner by clicking the required line, see Fig.9. The latter receives the player's business card, and then the partners enter a dialog information exchange (72). If the EGS contains no players meeting the set criteria, the initiator sends his invitations to those present (76) and then decides whether to stop partners selection or not.

To select a game, see Fig.14, the player initiates the game selection process (77), selects a game among those offered (78), see Fig.6, and receives a request "is the game active?" (79). If the answer is "yes", the player joins the specified game (79a). If the answer is "no", he is prompted to start the players selection mode (80) followed by a request "is the team formed?" (81). If the answer is "yes", the game starts, if "no" - the game selection procedure is repeated (78).

After the game is finished each of the players is scored and their accounts are settled, see Fig.15. This is done by summing up the points earned during the game (82), converting them into a money equivalent (83) and entering the wins and losses into players' accounts (84). In this case the player receives a request "are bank accounts activated?" (85). If the answer is "yes", electronic payments through banks are executed (86) to accomplish the settlements. If the answer is "no", a corresponding payment line is displayed for the player, see Fig.10. Thus the settlements are accomplished.

The EGS operates as follows: to initiate the EGS, each system subject has to go through the registration procedure by entering his code, pseudonym and password. After the data is entered the player is assigned a registration number with his identifying attributes logged in the CCS. Using his PCS, a player can enter the system through a telephone line any time of day suitable to him. Connection to the system is accomplished by starting one of the programs of the players registration system that dials through a modem the casino phone number and connects to the casino administrator computer. After the connection is established the registration system requests the player to enter his pseudonym, password and code, see Fig.5. Then the system compares the input data with the player's identifying attributes stored in the administrator computer. If they fully coincide, the customer is considered identified and is given the opportunity to use his deposit account that can be either a game or bank account. To perform specific gaming actions, a player chooses a game pseudonym by requesting appropriate data from the information tabulating, storing and searching system through the PCS interface, see Fig.5, selects the gaming team by entering appropriate data into the EGS through his PCS interface, see Fig.7,8 and 9, selects his game by entering appropriate data into the game selection system through

his PCS interface, see Fig.6. To form a desired gaming team, a EGS user sends a request or an advertisement to the mailing system or uses for this purpose other EGS communications systems. To preserve safety and confidentiality, all information exchange between the CCS and a PCS, and among the PCSs is protected by the information protection system, by security means of the data exchange system and - when settling accounts - additionally by security means of the electronic payments system. Each system uses a specific numeric identifier for each player. To perform all the necessary actions, a player gets acquainted with the rules and prompts stored in the reference system. After the game is over, the player's PCS interface displays a table with the results of the game and the operations performed on his deposit account, see Fig.10, 2b.

The game selection mode (see Fig.14) requires the following actions: the player initiates the game selection system (77) that displays the available games through the player's PCS and permits him to select one (78) by clicking it. Partners can be selected either before or after this procedure. So, after the game is installed, the players selection mode is initiated by starting the players search system (67), or the player switches over to join the selected game (79).

Throughout his presence in the EGS a player can dynamically switch over between different activated games and modes, and/or participate in one or several games at a time. The player can either monitor a gaming process or join it in an interactive mode. A player is also offered a possibility to wager or place bets with other players before the game starts or to monitor the process of scoring the points by the game results. All gaming events are logged in the recording system of the EGS. The scoring of points, see Fig.15, is done throughout the gaming process, with its results reflected in the player's game deposit account. After the game is over the account managing system converts the scored points into a money equivalent and the resulting sum is either added or subtracted from the player's bank account deposited with the EGS, provided the account was activated prior to the start of the game. After that electronic payments with the bank are executed (87).

So, each system user can play with any other user of said system at any time with an option of simultaneous participation in several games, and settle accounts by the results of the game through his bank without the necessity to abandon his current occupation.

A player does not have to leave his office or home and is not restricted by the casino working hours, i.e. he can play any time of day or night. Games are played anonymously with full privacy of data in the system and system protection against intrusion provided. Accounts are settled at will either in conventional points or by cashless operations with bank accounts, thus increasing security and forbidding a player to loose more money than is deposited on his account. All gaming events are logged, thus enabling a player to check the validity of all gaming actions and preventing possibility of fraud.

#### INDUSTRIAL APPLICABILITY

The invention can be successfully used for modeling real interrelationship among subjects of free market economy. The method of system control and adjustment relates to electronic network systems that use programmable control. The suggested gaming system can be applied for computerized modeling of real interrelationship among subjects of free market economy after the information pertaining to the processes to be modeled and a list of possible situations are entered into the system database.

#### Claims

1. An electronic gaming system consisting of a central computer station (1), composed of an administrator computer (23), a players registration system (3), a game accounts managing system (4), an information tabulating, storing and searching system (5), a system for recording gaming situations (6), a system for scoring by the results of the game (7), a wagering and betting system (8), an executive gaming system (9), a data exchange system (10); and peripheral computer stations (25), each comprising a system for admitting players to the central computer station (26), a gaming interface system (27); and distinctive by the fact that the central computer station (1) is equipped with an electronic payments system (11), an information protection system (12), a secure communications system (13), a game selection system (14), with the executive gaming system (9) realizing gaming situations from the database (16) of the executive gaming system (9) and the central computer station (1) interacting with peripheral computer stations (25) through a data exchange network (32) equipped with a communications station (20).
2. The electronic gaming system of claim 1 distinctive by the fact that the central computer station (1) and peripheral computer stations (25) include mailing systems (15).
3. The electronic gaming system of claim 1 or 2 distinctive by the fact that the secure communications system (13) comprises a personal communications system (33).

EP 0 843 272 A1

4. The electronic gaming system of claim 3 distinctive by the fact that peripheral computer stations (25) are connected by electronic communications with the administrator computer (23) or between themselves through a personal communications system (33).
- 5 5. The electronic gaming system of claim 4 distinctive by the fact that any two or more arbitrarily formed groups of peripheral stations (25) are interconnected by electronic communications through the personal communications system (33).
- 10 6. The electronic gaming system of claim 1 distinctive by the fact that the game selection system (14) includes a database (16"), describing and selecting different types of gaming situations in any combination of games for players.
7. The electronic gaming system of claim 1 or 6 distinctive by the fact that the information tabulating, storing and searching system includes a database describing and forming players teams and players rating (16") by any player-preset criterion.
- 15 8. The electronic gaming system of claim 1 distinctive by the fact that the peripheral computer stations (25) include computers (30) and modems (28) for both players and bank and/or other deposit game accounts.
9. The electronic gaming system of claim 1 distinctive by the fact that the central computer station (1) consists of a terminal (24) and a server (22) of the administrator (2) connected to a modem device (21).
- 20 10. The electronic gaming system of claim 1 distinctive by the fact that peripheral computer stations (25) are interconnected in any arbitrary combination by means of the central computer station (1) and a data transmission network (32).
- 25 11. A method of system control and adjustment implying that players are registered, the starting composition of players is selected, each player is scored in the selected game, and distinctive by the fact that each player is identified at his registration by a set of key attributes that are passed on to a central computer station (1) in an encoded form where they are compared with the individualized information in the information protection system (12); the information supplied by the player being individually encoded and sent as a message to the administrator (2) and the system subjects present; the starting composition of players is selected on the basis of the criteria offered by the information tabulating, storing and searching system (5) by directly indicating the specific criteria followed by an automatic adjustment of the computerized gaming system; the player is included into one or more games selected by him from a database list of players (16") and each player is scored by the results of each selected game with an automatic control of money transactions on bank and other player's accounts.
- 30 35 12. The method of claim 11 distinctive by the fact that in case the set of key attributes does not coincide at player identification, a registration failure is logged in the electronic protocol and the administrator (2) is advised thereof.
- 40 13. The method of claim 11 distinctive in the fact that a limited number of identification attempts is assigned, and in case it is exceeded the electronic gaming system is warned of an intrusion and the bank and other player accounts are blocked.

45

50

55



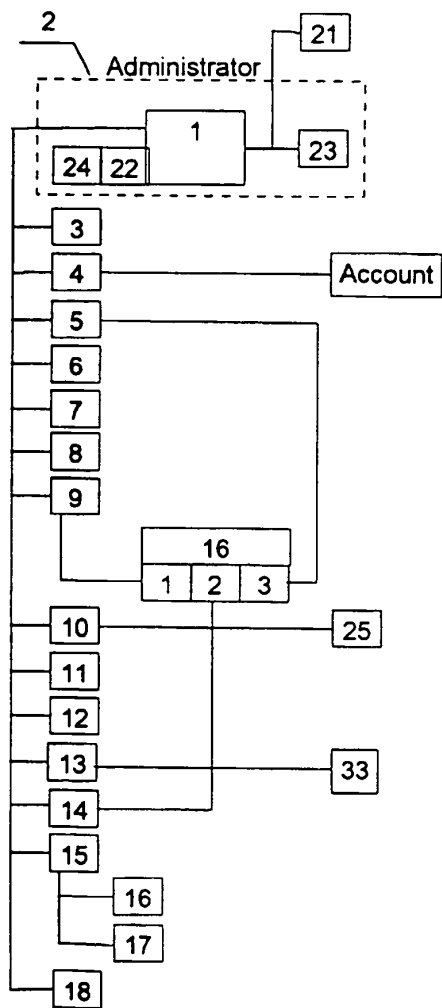

FIG. 1

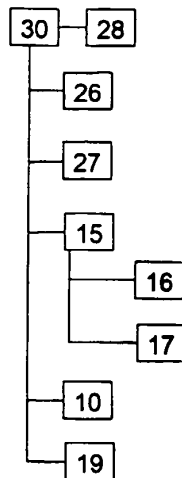

FIG. 2a

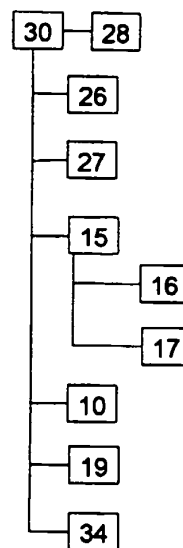

FIG. 2b

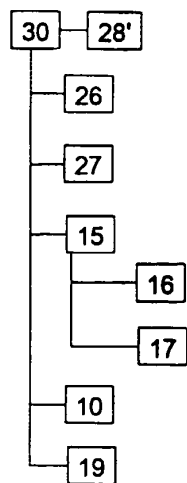

FIG. 2c

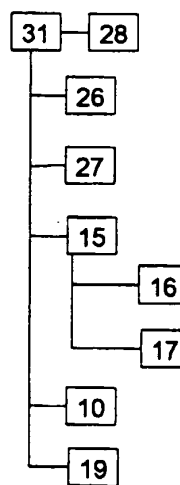

FIG. 2d

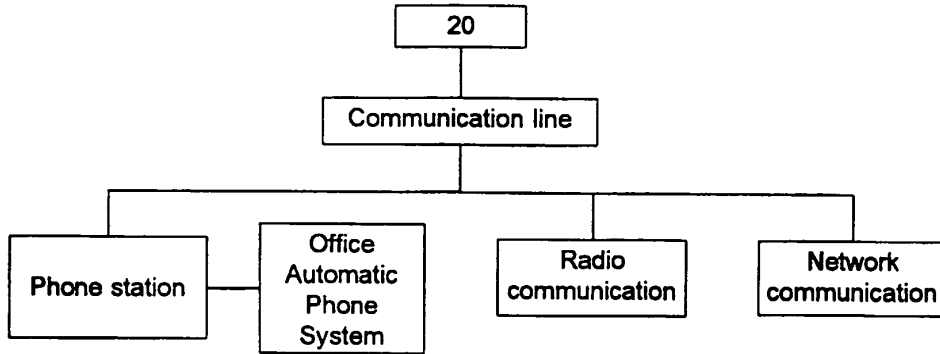

FIG.3.

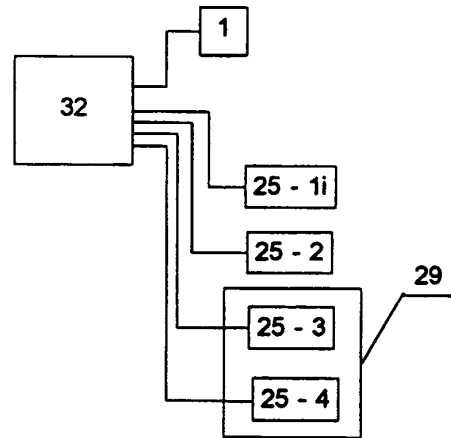

FIG.4

Please Enter
<b>Pseudonym:</b> <i>Alexsander</i>
<b>Password:</b> <i>Putnik239kros</i>
<b>Kode:</b> <i>45AV796</i>

FIG.5

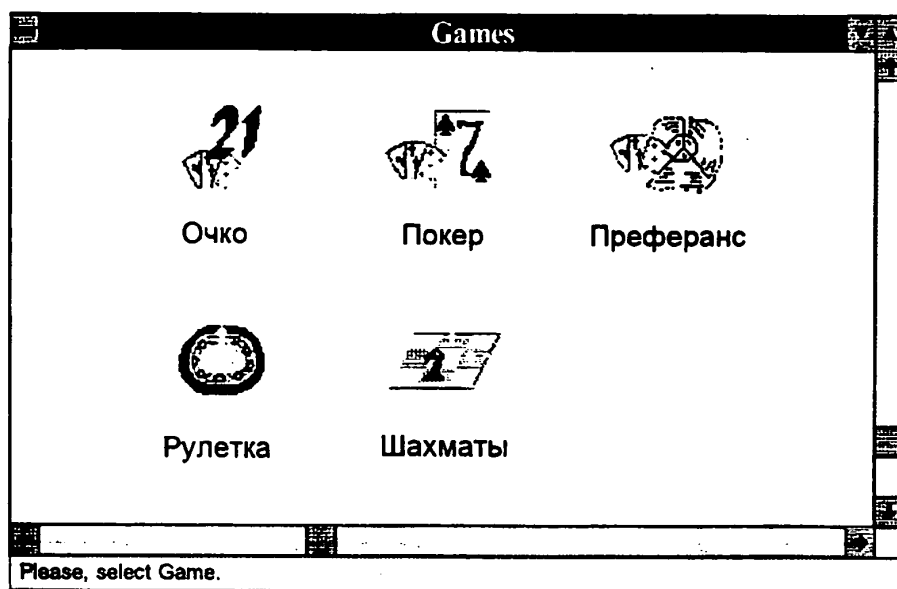

FIG.6

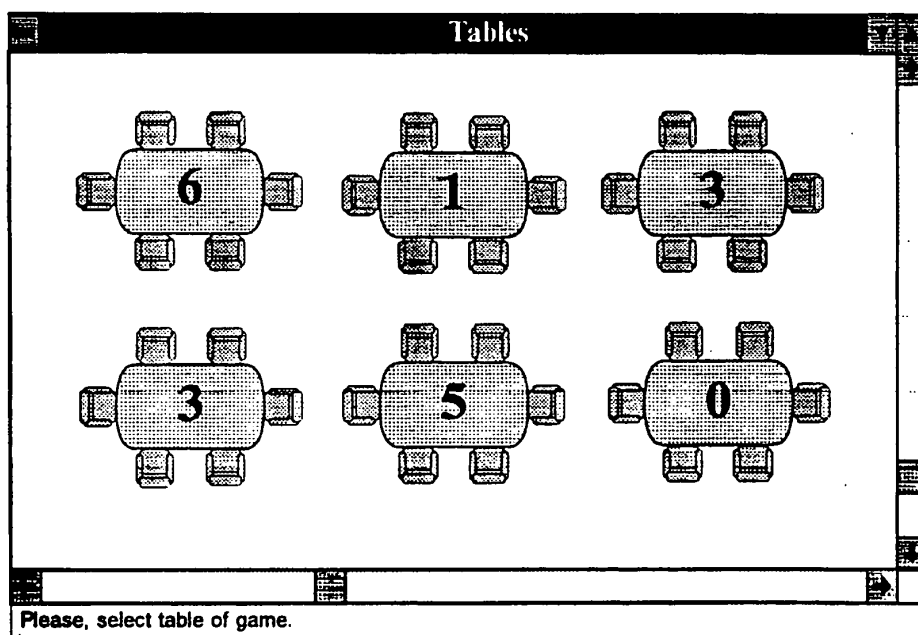

FIG.7

Users statistics					
N	Users	General Rating	Rating of "Покеп"	Rating of "О-ко"	Rating of "Рунетка"
1	Alexander	78	34	66	12
2	Boris Sergeevich	63	36	56	22
3	Victor	61	34	56	22
4	Dmitry	45	12	71	2
5	Ivan	45	12	71	2
6	Pal Palych	5	3	7	24

FIG.8

N	Users	Rating of "Покеп"
1	Victor	34
2	Ivan	12
3	Pal Palych	3

FIG.9

N	Users	Score	Current account
1	Alexander	45	345786
2	Boris Sergeevich	-4	_____
3	Victor	8	_____
4	Dmitry	3	_____
5	Ivan	-20	_____
6	Pal Palych	-32	_____

FIG.10

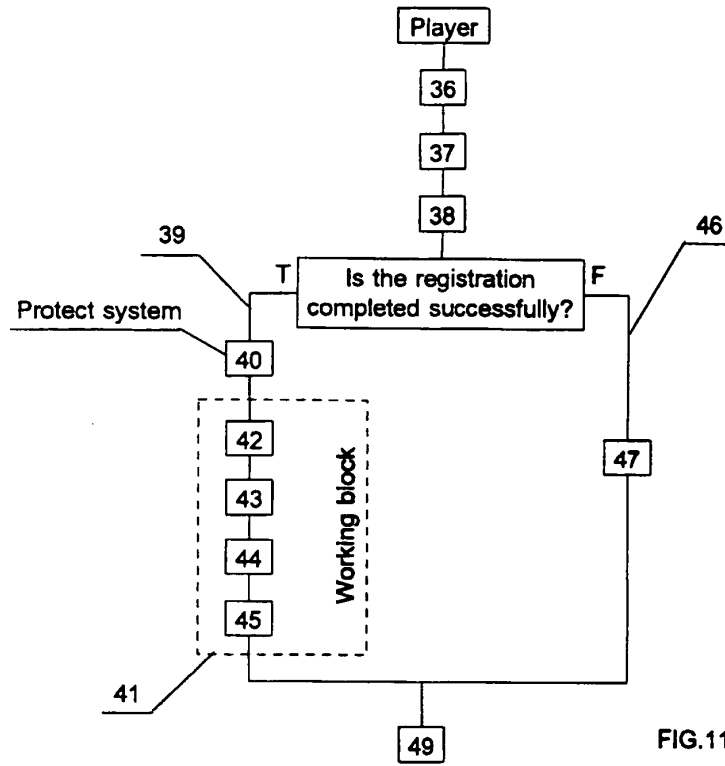

FIG. 11

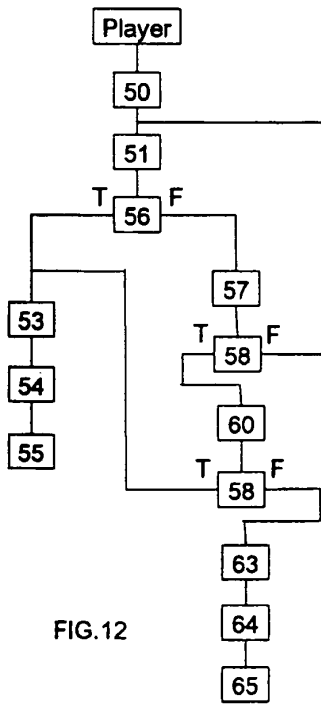

FIG. 12

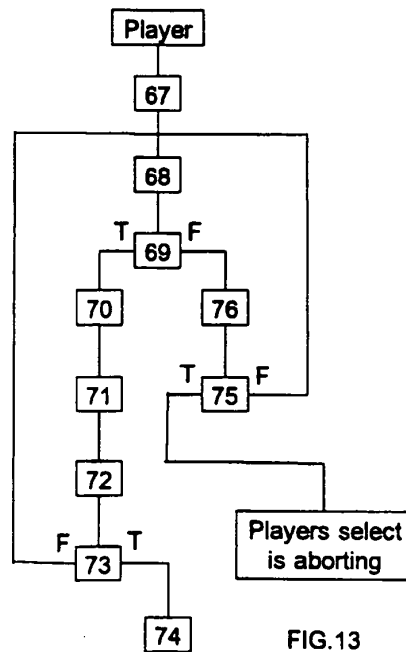

FIG. 13

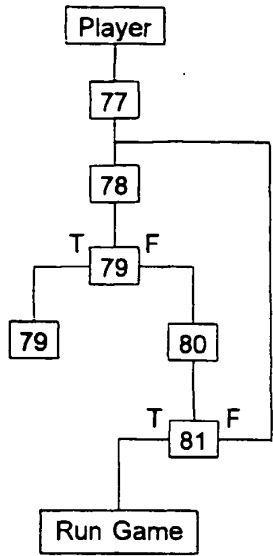

FIG.14

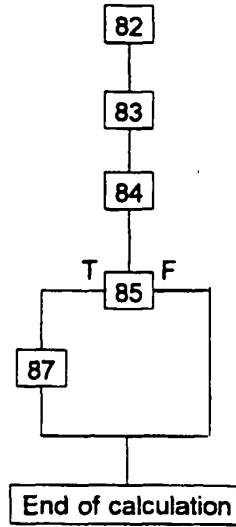

FIG.15

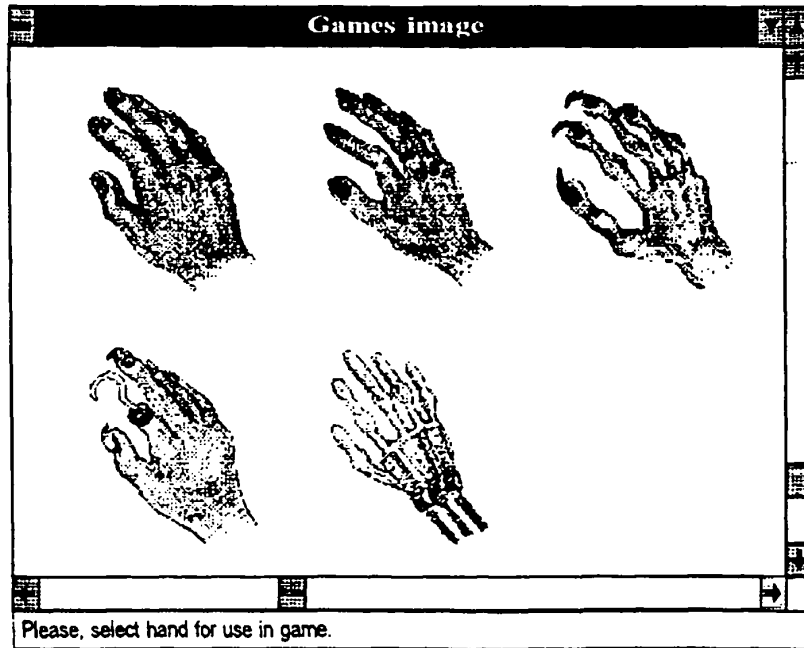

FIG.16

## INTERNATIONAL SEARCH REPORT

International application No.

PCT/RU 95/00241

<b>A. CLASSIFICATION OF SUBJECT MATTER</b>		
IPC6 G06F 19/00//G06F 161:00 According to International Patent Classification (IPC) or to both national classification and IPC		
<b>B. FIELDS SEARCHED</b>		
Minimum documentation searched (classification system followed by classification symbols)		
IPC6: G06F 19/00//G06F 161:00 INT5: G06F15/28, 15/30, 15/44, A63F 9/22, 9/24		
Documentation searched other than minimum documentation to the extent that such documents are included in the fields searched		
Electronic data base consulted during the international search (name of data base and, where practicable, search terms used)		
<b>C. DOCUMENTS CONSIDERED TO BE RELEVANT</b>		
Category*	Citation of document, with indication, where appropriate, of the relevant passages	Relevant to claim No.
A	WO, A1, 93/20526 (CALCULUS MICROSYSTEMS CORPORATION), 14 October 1993 (14.10.93)	1-10, 11-13
A	US, A, 5359510 (ANTHONY L. SABALIAUSKAS), 25 October 1994 (25.10.94)	1-10, 11-13
A	US, A, 4494197 (SEYMOUR TROY), 15 January 1985 (15.01.85)	1-10, 11-13
A	US, A, 4467424 (RICHARD A. HEDGES), 21 August 1984 (21.08.84)	1-10, 11-13
A	US, A, 4910677 (JOSEPH W. REMEDIO), 20 March 1990 (20.03.90)	1-10, 11-13
<input type="checkbox"/> Further documents are listed in the continuation of Box C. <input type="checkbox"/> See patent family annex.		
<p>* Special categories of cited documents:</p> <p>"A" document defining the general state of the art which is not considered to be of particular relevance</p> <p>"E" earlier document but published on or after the international filing date</p> <p>"L" document which may throw doubts on priority claim(s) or which is cited to establish the publication date of another citation or other special reason (as specified)</p> <p>"O" document referring to an oral disclosure, use, exhibition or other means</p> <p>"P" document published prior to the international filing date but later than the priority date claimed</p> <p>"T" later document published after the international filing date or priority date and not in conflict with the application but cited to understand the principle or theory underlying the invention</p> <p>"X" document of particular relevance; the claimed invention cannot be considered novel or cannot be considered to involve an inventive step when the document is taken alone</p> <p>"Y" document of particular relevance; the claimed invention cannot be considered to involve an inventive step when the document is combined with one or more other such documents, such combination being obvious to a person skilled in the art</p> <p>"&amp;" document member of the same patent family</p>		
Date of the actual completion of the international search		Date of mailing of the international search report
29 February 1996 (29.02.96)		5 March 1996 (05.03.96)
Name and mailing address of the ISA/ RU		Authorized officer
Facsimile No.		Telephone No.

Form PCT/ISA/210 (second sheet) (July 1992)



(12) **EUROPEAN PATENT APPLICATION**

(43) Date of publication:  
**18.03.1998 Bulletin 1998/12**

(51) Int. Cl.<sup>6</sup>: **G07F 17/32**

(21) Application number: **97115733.4**

(22) Date of filing: **10.09.1997**

(84) Designated Contracting States:  
**AT BE CH DE DK ES FI FR GB GR IE IT LI LU MC  
 NL PT SE**

• Luciano, Robert A., Jr.  
 Reno, Nevada 89509 (US)  
 • Saffari, Ali  
 Reno, Nevada 89509 (US)

(30) Priority: **10.09.1996 US 711847**

(71) Applicant:  
**International Game Technology  
 Reno, Nevada 89511-8986 (US)**

(74) Representative:  
**Pellkofer, Dieter Dr. et al  
 Manitz, Finsterwald & Partner  
 Patent- und Rechtsanwälte  
 Robert-Koch-Strasse 1  
 80538 München (DE)**

(72) Inventors:  
 • Berg, David A.  
 Reno, Nevada 89502 (US)

(54) **Central random number generation for gaming system**

(57) A gaming system is provided in which a central computer broadcasts a plurality of random number seeds serially for simultaneous receipt of each seed by a plurality of gaming terminals. Each gaming terminal uses the seed to generate a random number which determines the win/loss outcome. Two terminals configured to play the same game which receive the same random number seed will generate the same random number.

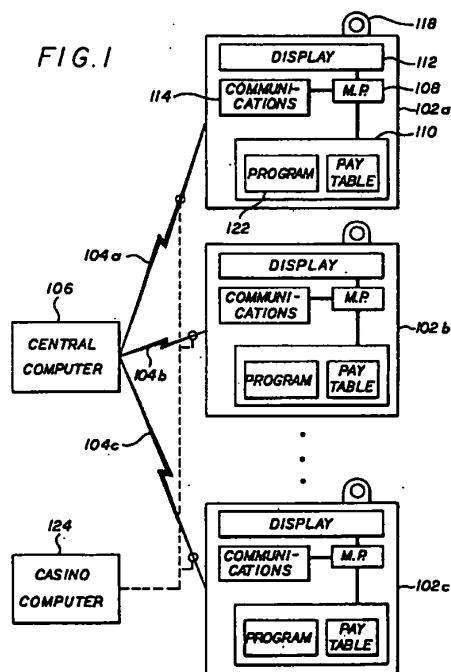



## Description

The present invention relates to a gaming system in which win/loss determination for a particular gaming station is determined by information transmitted from a central computer to a plurality of gaming stations and in particular to a device in which users perceive their gaming decisions as influencing the outcome, even though the outcome is determined from a central computer.

## BACKGROUND INFORMATION

A number of gaming systems include gaming stations or terminals, typically electronic terminals, although partially-mechanical terminals are also possible. Examples of electronic gaming terminals include electronic slot machines, electronic poker-playing machines, electronic keno machines and the like. In a typical situation, a plurality of such machines are provided and a user activates or initiates play on one or more of such machines by an action such as inserting a coin in a coin slot, inserting a credit card and/or smart card, making a selection by a push button, touch screen, etc., e.g. to make a wager. After play is initiated by a user, the gaming terminal determines whether the user has won or lost and outputs this information and/or makes a payoff to the user.

In some situations it is desired that the win/loss determination at given electronic terminals should be determined at a central location, such as a central computer coupled to two or more gaming terminals. Such central determination of win/loss may be mandated by governmental regulations or may be desired in order for a casino or other entity to maintain proper records, control the gaming, reduce or prevent cheating, etc.

In such a centrally-controlled operation, the perception of the user can be important. It is believed that in many situations, the maximum entertainment value of such gaming is achieved when players or users subjectively believe that their manner of play and/or decision to play/not play at a particular time and/or at a particular station influences the win/loss outcome. For example, players often want to feel that they have a better chance of winning if they play selectively at those places or those times when they "feel lucky." It is believed that the entertainment value of gaming is reduced if the players believe that, at the time the game is played, the decision as to whether they win or lose has already been made, and/or is centrally made. Similarly, players wish to believe that two persons playing the same game on two different machines will not necessarily achieve the same win/loss results.

Accordingly, it would be advantageous to provide a system in which the win/loss decision at any of a plurality of electronic terminals is determined by a central computer, (in the sense that, for two machines playing the same game, when they are played in an identical fashion, if one machine is a winner the other will also be

a winner) and yet to increase entertainment value by providing players with a situation in which they perceive that the decision whether and when to play changes the win/loss outcome.

It would be further advantageous to provide a system in which some of the gaming terminals are configured for playing games different from those of other terminals. For example, some terminals may be configured as slot machine-type games while others may be configured as poker-type games. Some gaming terminals may be configured to simulate three-reel 22-position slot machines while others may be configured to simulate five-reel machines each with hundreds or thousands of reel positions (so-called "virtual reel" machines). It would be advantageous to provide this type of gaming environment while still achieving the centrally-generated random number feature, preferably without the need to duplicate elements of the central computer and/or communication links therewith.

## SUMMARY OF THE INVENTION

According to the present invention, a central computer outputs random numbers or game outcome seeds (such as random number seeds) to a plurality of gaming terminals with the central computer outputting numerous game outcome seeds, one after another, preferably on a periodic basis wherein each seed which is broadcast can be received by a plurality of gaming terminals, preferably substantially simultaneously. Each gaming terminal can output a win or loss outcome based on any game outcome seed received from the central computer. Which of the seeds is used for making the win/loss determination at a given gaming terminal depends upon the time at which a user selects or activates that terminal, such as by placing a wager, pushing a button, making a touch screen selection, pulling a lever arm, and the like. In one embodiment, the central computer outputs game outcome seeds at a high frequency, preferably sufficiently rapidly that it would be unlikely for any two machines to be activated or selected at the same time. For example, if random number seeds are broadcast to all connected gaming terminals once every 250 milliseconds, any two gaming terminals would receive the same random number seed only if the players at those two machines activated the machines within 250 milliseconds of one another. Because this near-simultaneous activation would typically be a rare event, the entertainment value of the game will be enhanced because it will be the perception of the players that their decision as to whether and when to play a given machine affects the win/loss outcome (regardless of the fact that the ultimate win/loss determination for any given machine is made at a central computer which simultaneously controls win/loss decisions of a plurality of connected gaming terminals).

### BRIEF DESCRIPTION OF THE DRAWINGS

Fig. 1 is a block diagram of a gaming system according to one embodiment of the present invention;

Fig. 2 depicts a format for transmitting a random number seed according to an embodiment of the present invention;

Fig. 3 is a flow chart of a process for generating and broadcasting periodic random numbers according to an embodiment of the present invention;

Fig. 4 is a flow chart for using centrally generated random number seeds received from a central computer for playing a poker game according to an embodiment of the present invention;

Fig. 5 is a flow chart of a process for using a centrally generated random number seed for playing a keno game according to an embodiment of the present invention;

Fig. 6 is a flow chart of a process for using a centrally generated random number seed for playing a slot machine game according to an embodiment of the present invention.

### DETAILED DESCRIPTION OF THE PREFERRED EMBODIMENTS

As depicted in Fig. 1 according to one embodiment of the invention, each of a plurality of gaming terminals 102a, 102b, 102c is coupled via communication links 104a, 104b, 104c to a central computer 106. A number of types of gaming terminals can be used. In the depicted embodiment, each gaming terminal has a microprocessor 108 coupled to a memory 110, a display or other output device 112, and a communications facility 114. The terminal 102 also includes a device for permitting the user to use or activate the device such as by placing a wager, e.g., using coin slot 118 or other activation device such as a credit card slot, a bill verifier, a smart card receiving slot, a keyboard for receiving an identifier code, one or more buttons by which a user may initiate and/or control play which, if desired, may include touch screen ("virtual") buttons, e.g., presented on the display screen 112, and/or a slot machine-style lever (not shown). The microprocessor 108 operates in accordance with a program 122 stored in memory 110 (or stored in a separate memory such as an EEPROM or flash memory). Although it is possible to provide for all terminals which are coupled to the central computer 106 to be configured to play the same type of game, preferably, the terminals 102 and the programs 122 therein, are configured so that different terminals may be used for playing different types of games, e.g., such that some terminals may be used for playing a slot machine-style game, others may be used for playing a poker-style game, others may be used for playing a keno-style game, and the like. In one embodiment, some or all terminals may be configured so that they

may be used for playing any of a plurality of different games, as selected by casino personnel and/or as selected by the user. In the depicted embodiment, the memory 110 of each terminal 102 stores pay table information, i.e., information which determines, for a given game result, whether that result represents a winning result or a losing result and, if a winning result, the type and/or amount of the payout for such win. If desired, different terminals 102 may be provided with different pay tables, even for terminals which are configured to play the same game. The general manner of constructing a program to control a microprocessor so as to permit a user to play various games and output results is well-known in the art and the manner of constructing the program to further implement the present invention will be understood by those of skill in the programming art after understanding the present disclosure.

The communications device 114 can be any of a plurality of devices known to those of skill in the art for receiving data communication and placing it in a format suitable for transmission to the microprocessor 108. In one embodiment, as described below, communication between the terminals 102 and the central computer 106 is two-way communication so that the communications device 114 also acts to transmit information from the microprocessor to the central computer 106.

The communication links 104 can be of various types, including coaxial cable, telephone cable, optical fiber, microwave communication links, infrared communication links, and the like. In one embodiment, a second computer 124 is coupled to the communication links 104a, 104b, 104c for monitoring the communications, e.g., for bookkeeping and/or security purposes, which may be a computer specific to a particular casino or other geographic location or a subdivision thereof.

Although it is possible, in one embodiment, to provide a system in which the central computer 106 outputs random numbers which are directly used by each of the gaming terminals 102, (if necessary, with translation to a format and/or range suitable for use with a particular game) this configuration can be difficult to implement in a situation in which different types of games use different ranges of random numbers or in which some games may use more or fewer random numbers than others. For example, for a standard poker game, the deal requires the device to generate five (different) random numbers in the range of one through 52 (each number corresponding to one of the cards in a deck) and the draw requires generation of a variable number of random numbers which are different from the original five. The system can be configured either to use a single seed to generate all 5-10 random numbers or can use two or more seeds, e.g. by using one seed for each generated random number (taking care not to repeat numbers already generated.) In a standard keno machine, the microprocessor should generate a plurality of (different) random numbers, e.g. in the range of one through 80. Typically, the player picks as many numbers as

desired.

It would also be possible to provide several systems, each with a central random number generator and coupled terminals, e.g. with each system configured to play a different game, albeit at the cost of requiring more apparatus than might otherwise be needed.

In one embodiment one central computer 106 outputs game outcome "seeds" which are then used by the microprocessors 108 in each of the connected terminals to generate a random number which is appropriate for the particular game being played at that terminal. Transmission of game outcome seeds, (typically, a random number seed) rather than transmitting random numbers which are directly used by the gaming terminals, is believed to reduce the computational load on the central computer (which may additionally have security, bookkeeping or other duties) and the load on the communications links, albeit at the cost of additional computing at the gaming terminals.

Preferably, the relationship between the game outcome seed and the generated random number is deterministic in the sense that for any two gaming terminals which are configured for playing the same game, the random numbers generated by those two terminals will be the same if they are based upon the same seed, even though the microprocessors 108 in the two terminals are operating independently from one another. Procedures for generating a random number in a particular numerical range from a given random number seed are well known to those of skill in the programming art. The random number seed which is generated by the central computer 106 should have a range large enough to produce results in the gaming terminals which appear, at least subjectively to the users, to be random, but small enough to permit effective communication at a high frequency. In one embodiment, the random number seed is an 8-bit binary number (and thus is itself a random number). In one embodiment, the central system provides an associated identification tag for each seed that is transmitted, e.g. so that the seed can be identified and traced back later to check for or analyze instances of cheating.

Fig. 2 depicts one format for transmitting a random number seed although other formats can be used, as will be apparent to those of skill in the art. The random number seed is embedded in a 16-bit-wide field. In the depicted embodiment, the first three bits 202 signify an address, with 000 indicating a global address. The next two bits 204 are a function code indicating what type of communication the present 16-bit field represents. Preferably, at least one of the codes identifies this communication as a random number seed broadcast. The next eight bits 206 are the random number seed, in one embodiment, divided into first and second 4-bit nibbles, each organized with the least significant bit first. The final three bit field 208 is an error detection/correction field such as a cyclical redundancy check (CRC) field or a parity field. In one embodiment, the data is encrypted

by the central computer before transmitting over the links 104a, 104b, 104c and decrypted in the terminals 102 (and, optionally, the casino computer 124) according to decryption keys which may be downloaded, from time to time, or otherwise changed. Encryption assists in preventing cheating.

In one embodiment, the central computer may communicate information other than random number seeds. For example, the computer may poll various gaming terminals or other devices to verify status, retrieve stored data, detect signs of cheating or other irregularities and the like. Although a polling system is described, it is also possible to use an interrupt system, as will be apparent to those of skill in the art.

In one embodiment, the central computer may be configured to detect cheating by receiving status verification data from gaming terminals. In one embodiment a gaming terminal, in response to a poll, sends an electronic signature characteristic of its EEPROM or other component which the central computer can compare to the known correct or authorized signature stored in memory. In another embodiment, the central computer receives reports of wins or payouts from the various terminals. Since the central computer 106 can, if desired, keep a record of which random number seeds were generated at which times (and, if desired, associated identification tags) and can, if desired, keep information necessary to replicate the operation of any connected terminal, it is possible to use the central computer to determine, in response to a reported win, whether there was a random number seed broadcast to that terminal that should have resulted in a win.

The amount of spacing between sequentially-transmitted random number seeds depends on various factors. Although it is possible to configure a gaming terminal to wait for the first seed (or  $n^{\text{th}}$  seed) which is received after a coin drop (or other activation), in one embodiment it is preferred to avoid the wait by buffering or storing received seed and using the last seed (or  $n^{\text{th}}$ -to-last seed) received before activation of play on the terminal. In either case, the smaller the period between successive seeds, the less likely it is that two machines which are activated at about the same time will use the same random number seed. This is believed to provide for greater entertainment value and also to lessen the likelihood that a large number of terminals will receive the same top-winning random number seed and thus output a top-winning payout. Thus, if a new seed is transmitted every 250 milliseconds, two machines would have to be activated within 250 milliseconds of each other in order to use the same random number. On the other hand, more rapid generation of random number seeds places a greater computational burden on both the central computer 106 and the gaming terminals. Preferably, the spacing between successive random number seeds is sufficiently small to substantially prevent a single player from consistently activating two or more machines so as to use the same random

number seed. In one embodiment, random number seeds are broadcast by the central computer 106 such that successive seeds are spaced apart by about one second or less, preferably by about 500 milliseconds or less, more preferably by about 350 milliseconds or less, and even more preferably by about 250 milliseconds or less. In one embodiment, if there are two or more identical winning outcomes (e.g., if two or more systems get the same seed), the multiple winners will share in a pooled prize.

A number of methods can be used for generating periodic timing signals for broadcast of random number seeds. The embodiment depicted in Fig. 3 makes use of a periodic interrupt cycle of 10 milliseconds (1 centisecond). In this embodiment, the number of centiseconds to expire between broadcasts is stored in memory. When a period of 250 milliseconds is desired, the value stored in memory will thus be 25. At the beginning of the procedure this value (e.g. 25) is copied from memory into a counter 302. The counter is decremented 303 and then the computer waits until an interrupt occurs 304. After the interrupt has occurred (i.e. after the passage of 10 milliseconds) it is determined whether the current value of the counter is zero 306. If not 308 the procedure returns to the "decrement counter" step 303. If the counter has been decremented to zero it is determined whether a broadcast flag has been set 310. This permits using a flag to delay broadcast of a random number seed, e.g. if the central computer and/or communication link is engaged in a different, higher priority task. If the broadcast flag is not set, the computer returns to wait for the next interrupt cycle 304. Once the broadcast flag is set, the computer will generate a random number seed (using any of the plurality of random generation procedures well known to those of skill in the programming art) and broadcast the seed 312, properly formatted (Fig. 2) over the communication links 104.

Fig. 4 depicts a manner of using a random number seed in connection with a poker-type game. The procedure begins with activation of play in response to a user input 410 (such as a coin drop, a real or virtual button push, etc.). The gaming terminal microprocessor then determines 412 whether the communication link with the central computer appears to be currently active i.e. whether a random number seed has been received within the last 250 milliseconds. If the link appears to be lost, an appropriate "link lost" procedure will be implemented. Various options are available for this procedure. The microprocessor may freeze the operation of the terminal 414 preventing any further input or output, may, if desired, return money, or credit the account of the user 416 (or alternately may retain the wager), may notify the central computer and/or the casino, may display a signal light, generate a sound, and the like. In one embodiment, the microprocessor continues to monitor for re-establishment of the link 418 (optionally within a predetermined period) and upon regaining the link, automatically continues play.

If it appears that the link is still good, the microprocessor uses the next-received random number seed (or, if desired, a previously-received random number seed, such as the next-to-most-recently received seed, a seed randomly selected from among the ten most recently received seeds or the like) and, on the basis of this seed, generates five different random numbers 422 in the range of 1 through 52. The microprocessor then displays images of playing cards 424 which correspond to the five random numbers that were generated. The microprocessor waits for a period of time to permit the user to select which, if any, of the cards to discard, optionally permitting another wager 426. Following the discard selection, the microprocessor must select draw cards to replace the discarded cards. These draw cards will be selected by generating between one and four random numbers (depending on the number of cards discarded) in the range of 1-52, but not including cards previously included in the deal. Although it would be possible to use the same seed that was used in connection with the deal, in one embodiment it is preferred to use a different seed for the random number generation for draw cards. It is believed that using a second random number both increases the perception of user choice (and thus increases the entertainment value) and also provides for a smaller likelihood of cheating. Accordingly, the device once again determines whether the communication link is still active 428. If the communication link is not active, the procedure branches to a link loss operation which may be identical to the first link loss operation or may be different for the deal and draw situations. If there has not been a loss of communication, the microprocessor uses the next random number seed received from the central computer to generate random numbers corresponding to draw cards to replace the discarded cards 432. The microprocessor then compares the five-card hand with a pay table to determine whether the hand is sufficiently good to justify a win or payoff 434. If there is a win determination, the microprocessor may take various actions such as crediting the account of the user, making an appropriate entry in a user's smart card, controlling a pay-out hopper to place coins into a pay-out tray, placing an appropriate pay-out display on the display screen, generating sounds, lights, and the like. The microprocessor then returns to the original state.

Fig. 5 is a flowchart similar in some respects, to the flowchart Fig. 4 but showing a procedure for playing a Keno game. In Fig. 5, after the user initiates play e.g. by making a wager 510, and choosing up to ten numbers in the range 1-80 512, the microprocessor checks to see whether the communication link is good 514. If not, the microprocessor institutes a "link lost" procedure which may include, e.g. freezing the gaming terminal 516 (i.e. refusing to accept further user input or to provide normal gaming output.) If the communication link is good (or if a lost link is recovered) the microprocessor uses the next seed received from the central computer to cal-

calculate twenty different random numbers in the range of 1-80 518. The microprocessor then determines wins and losses by comparing the number of matches between the user-selected numbers and the generated numbers to a pay table and outputs the results e.g. by reporting to the central computer and/or casino computer, placing an appropriate indication on the display screen, crediting the user's account or smart card, outputting coins or other pay-out and the like 520.

Fig. 6 is a flowchart of a procedure similar to that depicted in Fig. 5 but used for playing a slot machine type game. In the embodiment of Fig. 6 after the user makes a wager 610 such as by inserting a coin in a coin slot, pushing a reel or a virtual button, pulling a lever, and the like, the microprocessor determines whether the communication link is good 612. If the communication link is not good, the microprocessor institutes a "link lost" procedure which may include, e.g. freezing the gaming terminal 614. If the communication link is good and/or if a lost communication link is reestablished, the microprocessor uses the next seed received from the central computer to calculate three different random numbers 616. Each of the random numbers is in a range corresponding to the number of stop positions on the three slot machine reels (or virtual reels, in the case of an electronic slot machine). If there are more than three reels or virtual reels, more than three numbers will be generated. The microprocessor then displays the results such as by displaying a symbol associated with the stop position for each reel (or virtual reel) and determines wins/loss by comparing the symbols at the stop positions with the pay table and outputs the results 618. It should be recognized that other schemes for selecting reel stop positions using a random number may be apparent to one of skill in the art.

In light of the above description number of advantages the present invention can be seen. The invention provides for central generation of win/loss information for a plurality of gaming terminals, but still preserves entertainment value by providing the perception that selection of when and whether to play a particular terminal affects the outcome. Communication of the information is provided in such a way as to permit accounting, taking appropriate action when a communication link is lost, and guarding against cheating.

A number of variations and modifications of the invention can be used. Some aspects of the invention can be used without using other aspects. For example, it is possible to provide rapid spaced-apart random number seeds without making transmission of the seeds strictly periodic. It is possible to transmit different seeds to different groups of terminals. It is possible to transmit different information at the same time by multiplexing messages over communication links. It is possible to provide for remote gaming such as gaming using a dial-up terminal, communication over a global communication systems such as the Internet, communicating over telephone lines, television or other broadcast cable

lines.

Although the invention has been described by way of a preferred embodiment in certain variations and modifications other variations can also be used, the invention being defined by the following claims:

#### Claims

1. A method for using a gaming system comprising:
  - providing a central computer;
  - coupling said central computer to at least one gaming terminal having a terminal processor configured for playing a game;
  - transmitting a series of game outcome seeds from said central computer substantially simultaneously to each gaming terminal;
  - initiating play at a first of said plurality of gaming terminals by calculating a first random number in a range selected for said game of said first gaming terminal, in response to a user action occurring at a first time, wherein said first random number is based on a game outcome seed received at said first gaming terminal from said central computer at said first time;
  - initiating play at a second of said plurality of gaming terminals by calculating a second random number in a range selected for said game at said gaming terminal, in response to a user action occurring at a second time, wherein said second random number is based on a game outcome seed received at said second gaming terminal from said central computer at said second time; and
    - wherein said terminal processors are configured such that when said first and second terminals are configured for playing an identical game when play is initiated on both at predetermined times and when said first and second game outcome seeds are identical, said first and second random numbers calculated by the terminal processors of said first and second gaming terminals will be identical.
2. A method as claimed in claim 1 wherein said period is less than about 250 milliseconds.
3. A method as claimed in claim 1 wherein said central computer is coupled to a plurality of gaming terminals.
4. The method as claimed in claim 3 wherein said games of at least two of said plurality of gaming terminals are different.
5. A method as claimed in claim 1 wherein said transmitting of a series of game outcome seeds occurring at predetermined times.

- 6. A method as claimed in claim 1 wherein said transmitting game outcome seeds are spaced apart by at least a predetermined period.
- 7. A method as claimed in claim 1 wherein said step of transmitting over a communication link selected from among coaxial, telephone cable, fiber optics, microwave links, and infrared links.
- 8. A method as claimed in claim 7 wherein said communication link is used for transmitting a second type of information different from said random number seed.
- 9. A method as claimed in claim 8 wherein said second type of communication includes a polling signal transmitted from said central computer to at least a first of said gaming terminals.
- 10. A method as claimed in claim 8 wherein said second type of communication link includes information sent from said gaming terminal to said central computer.
- 11. A method as claimed in claim 1 wherein said game of at least one of said plurality of gaming terminals uses first and second random numbers based on first and second random number seeds received at said gaming terminal at first and second different times.
- 12. A method as claimed in claim 1 further comprising detecting loss of a communication link between said central computer and said gaming terminal.
- 13. A method as claimed in claim 12 further comprising suspending game play in response to said step of detecting.
- 14. A method as claimed in claim 12 further comprising returning or crediting wagers placed but not yet played in response to said detecting.
- 15. Apparatus for a gaming system comprising:
  - a central computer;
  - a plurality of gaming terminals coupled to said central computer by communication links, each terminal having a terminal processor configured for playing a game;
  - said central computer being programmed to transmit a series of random number seeds from said central computer substantially simultaneously to each of said plurality of gaming terminals, said transmitting of each of said random number seeds being spaced apart by at least a predetermined period;
  - said terminal processor of each gaming terminal

- being programmed to calculate at least a first random number in a range selected for said game of said gaming terminal in response to a user action based on a random number seed received from said central computer;
  - wherein said terminal processors are configured such that when first and second terminals are configured for playing identical games and when said first and second terminals receive identical random number seeds identical first and second random numbers will be calculated by the terminal processors of said first and second gaming terminals.
- 16. Apparatus for using a gaming system comprising:
  - a central computer;
  - a plurality of gaming terminal means, each terminal means having a terminal processor means configured for playing a game;
  - means for coupling said central computer to said plurality of said gaming terminals;
  - means for transmitting a series of random number seeds from said central computer substantially simultaneously to each of said plurality of gaming terminals, said transmitting of each of said random number seeds being spaced apart by at least a predetermined period;
  - means, in a first of said gaming terminals, for initiating play by calculating a first random number in a range selected for said game of said first gaming terminal, in response to a user action occurring at a first time, wherein said first random number is based on a random number seed received at said first gaming terminal from said central computer at said first time;
  - means in a second of said plurality of gaming terminals, for initiating play by calculating a second random number in a range selected for said game at said gaming terminal, in response to a user action occurring at a second time, wherein said second random number is based on a random number seed received at said second gaming terminal from said central computer at said second time;
  - wherein said terminal processors are configured such that when such first and second terminals are configured for playing identical games and when such first and second random number seeds are identical, said first and second random numbers calculated by the terminal processors of said first and second gaming terminals will be identical.
- 17. The apparatus of claim 16 wherein said means for transmitting a series of random number seeds

includes a processor in said central computer and a stored computer program.

18. Apparatus as claimed in claim 16 wherein said means in said first of said plurality of gaming terminals includes a processor and a stored computer program. 5
19. A method for using a gaming system comprising: 10
- providing a central computer;
  - providing a plurality of gaming terminals;
  - transmitting a series of random number seeds from said central computer to each of said plurality of gaming terminals;
  - receiving a user input at least a first of said gaming terminals at a first time;
  - calculating a random number at said first gaming terminal based on one of said series of random number seeds wherein one of said random number seeds is selected by said first terminal on the basis of the time of its receipt relative to said first time. 15 20
20. A method for playing a poker style game comprising: 25
- providing a central computer;
  - providing a plurality of electronic terminals, each of said plurality of electronic terminals including a microprocessor and a memory wherein said memory stores a program for playing a poker style game and a pay table for determining a win/loss result;
  - transmitting a plurality of random number seeds from said central computer to said electronic gaming terminal;
  - receiving a first user input at said first electronic terminal;
  - determining, in said first electronic terminal, whether the communication link between said first electronic terminal and said central computer is operable;
  - when said communication link is operable, calculating five deal random numbers in the range of 1-52 based on the next random number seed received from said central computer after said step of determining whether said communication link is operable;
  - displaying, on a display screen, coupled to said electronic terminal, images of five cards corresponding to said five random numbers;
  - receiving an indication of a wager from said user in said first electronic terminal; receiving from said user an indication of cards which said user chooses to discard in said first electronic terminal;
  - determining whether said communication link

is operable;

if said communication link is operable, calculating a number of draw random numbers equal to the number of cards selected as discard cards by said user in the range between 1-52, none of which are equal to said five deal random numbers to provide five hand random numbers based on the next seed received from said central computer after said step of determining whether said communication link is operable;

determining a win/loss result by comparing said five hand numbers to said pay table and outputting the result thereof.

21. A method for using the gaming system comprising:

- providing a central computer means for selecting random number seeds which are determinative of winning symbols or combinations of symbols;
- providing a plurality of electronic gaming terminals connected on-line to said central computer wherein said random number seeds are communicated from said central computer to said electronic terminals wherein the selection of random number seeds by said central computer is independent of any activation, play, or other manipulation by any user of an electronic terminal;
- said electronic gaming terminal means incorporating a microprocessor that makes random selections of symbols for players, allows said players to make such selections, or draws symbols from a central repository which are communicated to such central computer and displays on a video screen winning symbols or combinations thereof wherein said electronic terminal does not select said winning symbols and wherein said winning symbols are determined on the basis of at least one random number seed communicated from said central computer to said electronic gaming terminal, said random number seed being one of a plurality of seeds transmitted from said central computer to said electronic terminal and when the decision regarding which of said plurality of random number seeds is used for determining said winning symbols is a function of when a user wagers or otherwise activates said electronic terminal.

FIG. 1

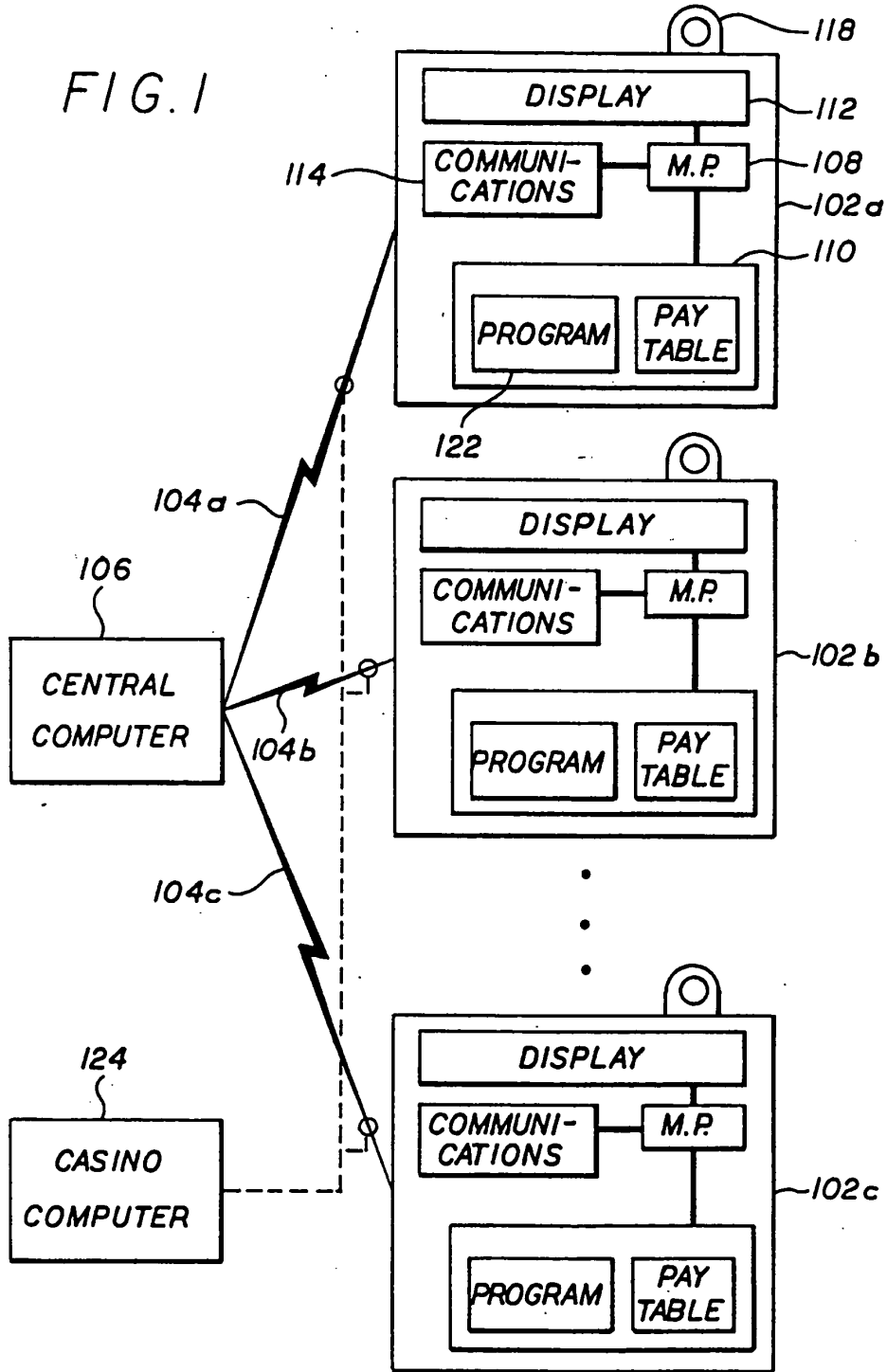
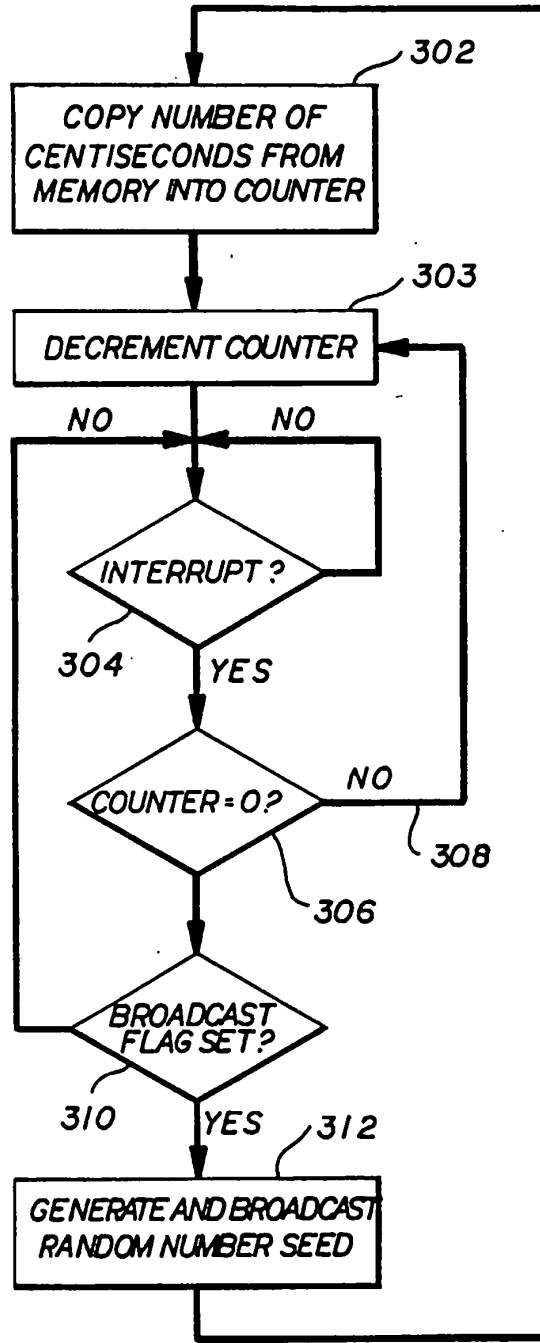



FIG. 3



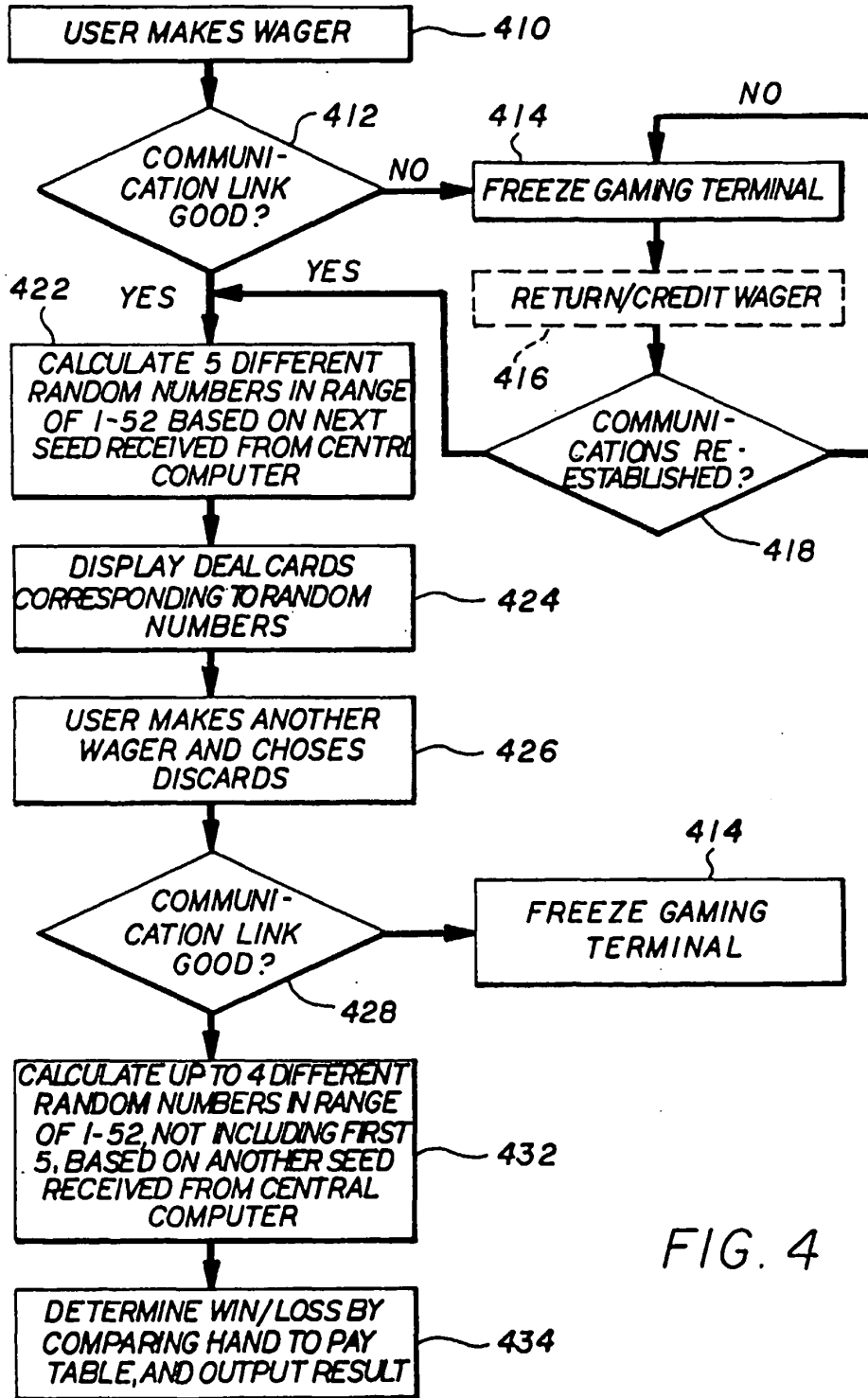

FIG. 4

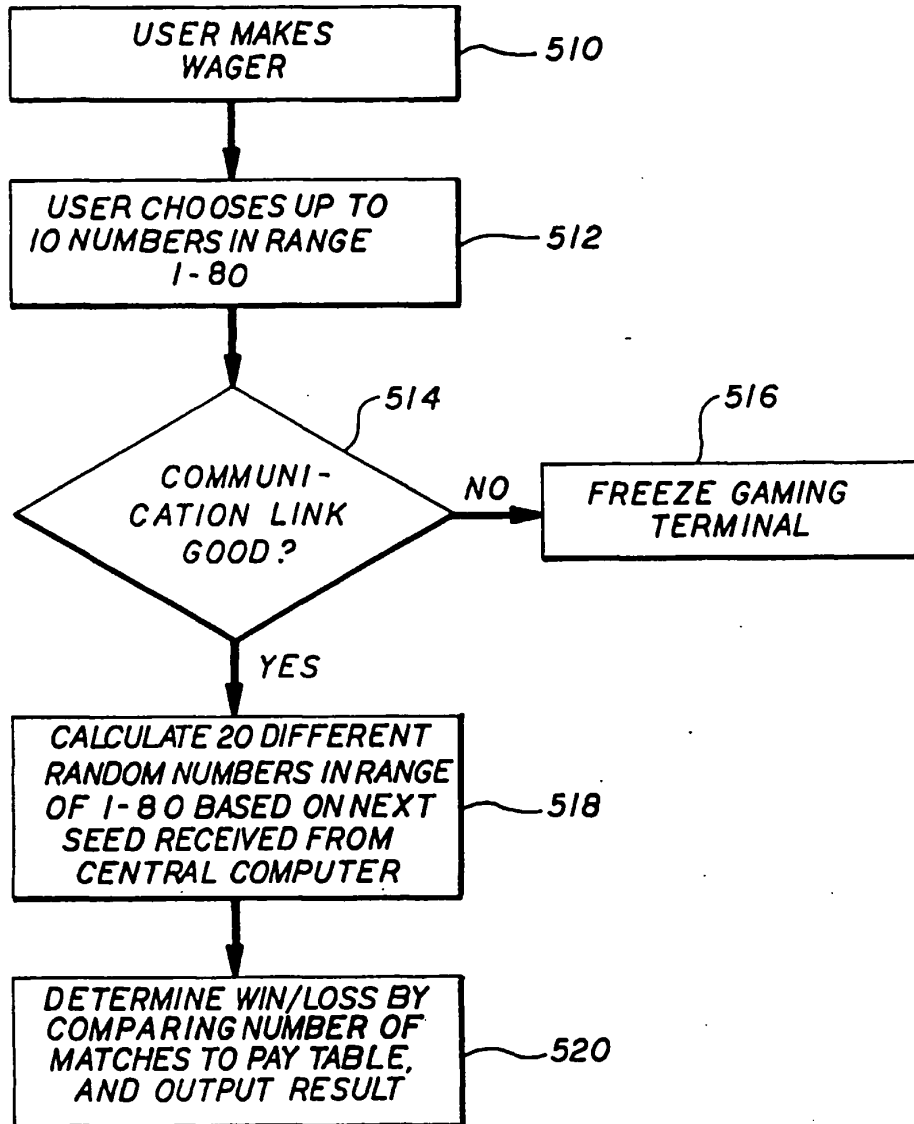

FIG. 5

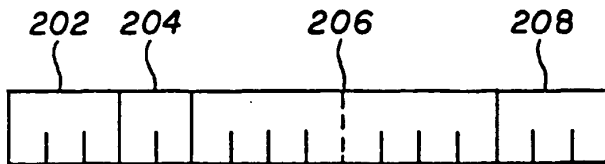

FIG. 2

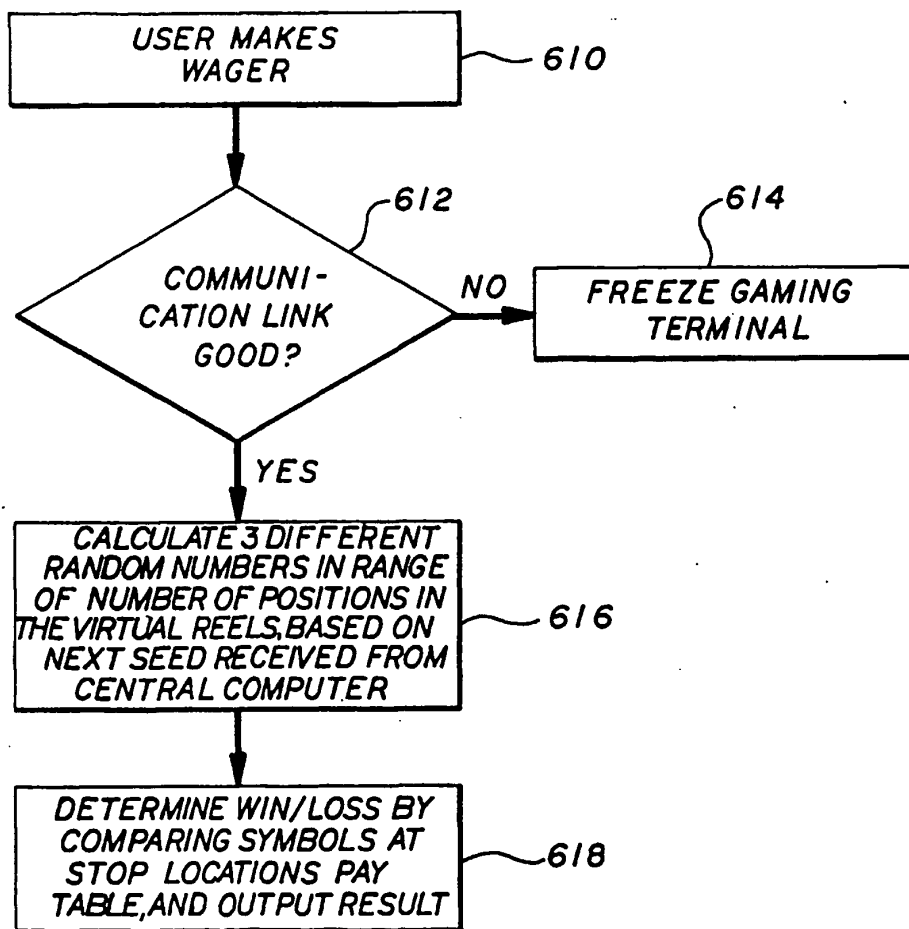
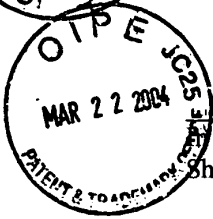
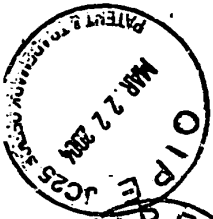

FIG. 6



I hereby certify that this correspondence is being deposited with the U.S. Postal Service with sufficient postage as First Class Mail, in an envelope addressed to: Commissioner for Patents, P.O. Box 1450, Alexandria, VA 22313-1450, on the date shown below.

Dated: March 18, 2004      Signature: *Susan B. Jensen* (Susan B. Jensen)

**IN THE UNITED STATES PATENT AND TRADEMARK OFFICE**

are Patent Application of:  
Shridhar P. Joshi

Application No.: 09/688501

Art Unit: 3714

Filed: October 16, 2000

Examiner: Alex P. Rada

For: METHOD OF TRANSFERRING GAMING  
DATA ON A GLOBAL COMPUTER  
NETWORK

**RECEIVED**

MAR 30 2004

TECHNOLOGY CENTER R3700

**REPLY TO OFFICE ACTION**

Commissioner for Patents  
P.O. Box 1450  
Alexandria, VA 22313-1450

Dear Sir:

**INTRODUCTORY COMMENTS**

This is in response to the Office Action dated December 17, 2003. The shortened statutory period for reply is three months from the mailing date, i.e., by March 17, 2004. This response is being submitted with a petition for a one-month extension of time.

**Amendments to the Claims** are reflected in the listing of claims which begins on page 2 of this paper.

**Remarks/Arguments** begin on page 12 of this paper.

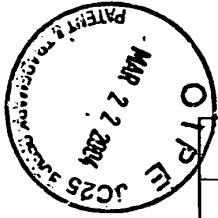

<b>AMENDMENT TRANSMITTAL LETTER</b>			Docket No. 47079-00077USPT		
Application No. 09/688501	Filing Date October 16, 2000	Examiner Alex P. Rada	Art Unit 3714		
Applicant(s): Shridhar P. Joshi					
Invention: METHOD OF TRANSFERRING GAMING DATA ON A GLOBAL COMPUTER NETWORK					
<b>TO THE COMMISSIONER FOR PATENTS</b>					
Transmitted herewith is an amendment in the above-identified application. The fee has been calculated and is transmitted as shown below.					
<b>CLAIMS AS AMENDED</b>					
	Claims Remaining After Amendment	Highest Number Previously Paid	Number Extra Claims Present	Rate	
<b>Total Claims</b>	26	- 62 =	0	x 18	0
<b>Independent Claims</b>	4	- 4 =	0	x 86	0
Multiple Dependent Claims (check if applicable) <input type="checkbox"/>					
<b>Other fee (please specify):</b> Extension for response within first month					110.00
<b>TOTAL ADDITIONAL FEE FOR THIS AMENDMENT:</b>					110.00
<input checked="" type="checkbox"/> Large Entity <span style="margin-left: 200px;"><input type="checkbox"/> Small Entity</span> <input type="checkbox"/> No additional fee is required for this amendment. <input type="checkbox"/> Please charge Deposit Account No. _____ in the amount of \$ _____. A duplicate copy of this sheet is enclosed. <input checked="" type="checkbox"/> A check in the amount of \$ 110.00 to cover the filing fee is enclosed. <input type="checkbox"/> Payment by credit card. Form PTO-2038 is attached. <input checked="" type="checkbox"/> The Director is hereby authorized to charge and credit Deposit Account No. 10-0447 as described below. A duplicate copy of this sheet is enclosed. <input checked="" type="checkbox"/> Credit any overpayment. <input type="checkbox"/> Charge any additional filing or application processing fees required under 37 CFR 1.16 and 1.17.					
<u>Daniel Nguyen</u> Daniel G. Nguyen Attorney Reg. No.: 42,933			Dated: March 18, 2003		
JENKENS & GILCHRIST, A PROFESSIONAL CORPORATION 225 W. Washington, Ste. 2600 Chicago, Illinois 60606-3418 (312) 425-8513					
<div style="border: 1px solid black; padding: 10px; width: fit-content; margin: auto;"> <p style="font-size: 24px; margin: 0;"><b>RECEIVED</b></p> <p style="font-size: 18px; margin: 0;">MAR 30 2004</p> <p style="font-size: 14px; margin: 0;">TECHNOLOGY CENTER R3700</p> </div>					

**AMENDMENTS TO THE CLAIMS**

**Listing of Claims:**

This listing of claims will replace all prior versions and listing of claims in the application.

1-21. (Cancelled)

22. (Withdrawn) A method for transferring gaming data on a global computer network comprising:

receiving player identification information from outside of a gaming establishment;

analyzing said player identification information;

requesting player input regarding a random event;

receiving and analyzing said input;

generating a random number within said gaming establishment;

interpreting said random number to determine a text or graphical outcome; and

transmitting said outcome to a player through said global computer network.

23. (Withdrawn) The method of Claim 22, wherein said random event takes place in a microprocessor within a gaming machine located within said gaming establishment.

24. (Withdrawn) The method of Claim 22, wherein said random event takes place in a microprocessor within a gaming establishment server.

25. (Withdrawn) The method of Claim 22, wherein said global computer network is the Internet.

26. (Withdrawn) A method of receiving transferred data via a global computer network, comprising:

accessing a global computer network from outside a gaming establishment;

inputting identification information into said global computer network;

gaining access to a server within said gaming establishment;

requesting the generation of a random number, said random number being generated from within said gaming establishment; and

receiving a text or graphical outcome of said random number generation via said global computer network.

27. (Withdrawn) The method of Claim 26, wherein said global computer network is the Internet.

28. (Withdrawn) The method of Claim 26, wherein said generation of said random number is accomplished at a gaming machine within said gaming establishment.

29. (Withdrawn) The method of Claim 26, wherein said generation of said random number is accomplished at a gaming establishment server.

30. (Withdrawn) The method of Claim 26, wherein the step of receiving is accomplished via said global computer network.



31. (Withdrawn) The method of Claim 26, wherein the step of receiving is accomplished through the Internet.

32. (Withdrawn) An interactive site on a global computer network comprising:  
a page including one or more game choices to allow a player to participate in a remote random event;  
data means to input data;  
outcome means to receive text or graphical outcomes of a remote random event; and  
notification means to notify said player of said outcomes.

33. (Withdrawn) The interactive web site of Claim 32, wherein said page is an Internet-based World Wide Web page.

34. (Withdrawn) The interactive web site of Claim 32, wherein said remote random event occurs in a slot machine.

35-36. (Cancelled)

37. (Currently Amended) A remote gaming method comprising:

- accessing, via a remote terminal, a gaming site on a global computer network connected to said remote terminal;
- providing, via said remote terminal, personal identification information to said gaming site;
- selecting, via said remote terminal, a game of chance on a gaming machine located at a gaming establishment for remote play, said remote terminal being located outside said gaming establishment;
- placing, via said remote terminal, a wager for playing said selected game; and
- receiving randomly-generated text or graphical outcome data at said remote terminal for said selected game, said outcome data being generated by the gaming machine at said gaming establishment and relayed to said gaming site through a gaming server connected to said gaming site.

38. (Previously Amended) A remote gaming method using a gaming server, a remote terminal, and a gaming site on a global computer network, said gaming server being located at a gaming establishment, said remote terminal being located outside said gaming establishment, said gaming site being provided on said global computer network, the method comprising:

- receiving, at said gaming server, personal identification information, game selection information, and wager information from a player accessing said gaming site via said remote terminal, said remote terminal being connected to said global computer network;

- randomly generating outcome data at a gaming machine communicatively coupled to said gaming server, said outcome data being generated for a game selected

according to said game selection information, said gaming machine being located at said gaming establishment;  
receiving said outcome data at said gaming server; and  
transmitting said outcome data from said gaming server to said gaming site for display to said player on said remote terminal in text or graphical form.

39. (Previously Presented) A method for playing a gaming machine located inside a gaming establishment from a remote terminal located outside the gaming establishment comprising:

establishing a communication link between said remote terminal and a gaming site on a global computer network, said gaming site in communication with a gaming server for collecting outcome data from gaming machines located inside the gaming establishment;  
selecting a gaming machine at said gaming establishment using said remote terminal;  
making a wager to play the selected gaming machine;  
receiving outcome data, including game outcome, at said remote terminal resulting from a play of said gaming machine; and  
generating a payout if said game outcome meets predetermined criteria.

40. (Previously Presented) The method of claim 39 wherein said outcome data comprises information identifying the value of said payout; and further comprising the step of using said payout information to simulate a display of said game outcome at said remote location.

41. (Previously Presented) The method of claim 39 further comprising using said outcome data to simulate a display of said game outcome on said remote terminal.

42. (Previously Presented) The method of claim 39, wherein said selected gaming machine comprises a slot machine and wherein said game outcome data includes a reel position.

43. (Previously Presented) The method of claim 39 wherein said selected gaming machine comprises a video poker machine including a display for displaying a poker hand.

44. (Previously Presented) The method of claim 39 wherein said step of receiving outcome data includes receiving outcome data from a plurality of gaming machines for remote play.

45. (Previously Presented) The method of claim 44 wherein said step of receiving outcome data includes receiving a gaming machine identifier.

46. (Previously Presented) The method of claim 44 wherein said step of receiving outcome data includes receiving a gaming machine type.

47. (Previously Presented) The method of claim 44 wherein said step of receiving outcome data includes receiving player preferences.

48. (Previously Presented) The method of claim 39 wherein said selected gaming machine comprises a slot machine and wherein said game outcome comprises information identifying a reel position of said gaming machine; and further comprising the step of using said outcome information to display said reel position on said remote terminal.

49. (Previously Presented) The method of claim 39 and further including the steps of receiving a player identifier; and transmitting said player identifier for identification of said player.

50. (Previously Presented) The method of claim 39 wherein said game outcome results from the server initiating game play on the selected gaming machine.

51. (Previously Presented) The method of claim 39 wherein said game outcome results from the manual game play on the selected gaming machine.

52. (Previously Presented) A remote computer for the remote play of a local gaming machine located within a gaming establishment and connected to a gaming server, the remote computer being located outside said gaming establishment, said remote computer connected to a gaming site through a global computing network served by said gaming server, said remote computer comprising:

a microprocessor;

memory connected to said microprocessor and including instructions for controlling said microprocessor; and

said microprocessor being operative with said instructions in said memory to:

receive information identifying a plurality of local gaming machines located within said gaming establishment from a gaming server;

transmit data selecting of at least one said plurality of local gaming machines for remote play;

receive a text or graphical outcome resulting from a local play of each said selected local gaming machine; and

generate a payout if said outcome meets predetermined criteria.

53. (Previously Presented) The remote computer of claim 52 wherein said selected gaming machine comprises a slot machine and wherein said outcome includes a reel position.

54. (Previously Presented) The remote computer of claim 52 wherein said operation of receiving information includes receiving information selecting at least two of said plurality of local gaming machines for remote play.

55. (Previously Presented) The remote computer of claim 52 wherein said operation of receiving information includes receiving a gaming machine identifier.
56. (Previously Presented) The remote computer of claim 52 wherein said operation of receiving information includes receiving a gaming machine type.
57. (Previously Presented) The remote computer of claim 52 wherein said operation of receiving information includes receiving player preferences.
58. (Previously Presented) The remote computer of claim 52 wherein said selected gaming machine comprises a video poker machine including a display for displaying a poker hand.
59. (Previously Presented) The remote computer of claim 52 wherein said outcome comprises data identifying the value of said payout; and further comprising the operation of using said payout data to simulate a display of said outcome at said remote location.
60. (Previously Presented) The remote computer of claim 52 wherein said outcome comprises information identifying a reel position of said selected gaming machine; and further comprising the operation of using said outcome data to display said reel position at said remote location.
61. (Previously Presented) The remote computer of claim 52 further including the operations of: receiving a player identifier; and transmitting said player identifier for identification of said player.

62. (Currently Amended) A remote computer located outside a gaming establishment, said gaming establishment having a plurality of gaming machines linked by a gaming server, said remote computer connected to a gaming site through a global computing network served by said gaming server comprising:

means for receiving information identifying a plurality of local gaming machines each engaged in play within said gaming establishment;

means for transmitting data from said remote computer for selecting at least one of said plurality of local gaming machines for information transfer;

means for receiving a text or graphical outcome resulting from a play of said selected local gaming machines; and

means for generating a payout if said outcome meets predetermined criteria.



**REMARKS**

Claims 37-62 were pending in this application. Claims 1-21, 35 and 36 were previously cancelled. Claims 22-34 were previously withdrawn. Claims 39-62 were previously added.

Claims 37 is currently amended in order to clarify that the outcome data is relayed to the gaming site through a gaming server connected to said gaming site. Support for the amendment may be found throughout the specification in general and at least on page 8, lines 7-9.

Claim 62 is currently amended in order to clarify that data is being transmitted from a remote computer. Support for the amendment may be found throughout the specification in general and at least on page 13, lines 3-5.

**Claim Rejections Over Roseman - 35 U.S.C. § 102**

Claims 37 and 38 were rejected under 35 U.S.C. § 102(e) as being anticipated by U.S. Patent No. 6,012,984 to Roseman ("Roseman"). The Office Action alleges that Roseman discloses the invention. In particular, as the Applicant understands it, the Examiner urges that the Roseman gaming server may be interpreted as a "gaming machine." (Office Action, page 3, lines 3-5.) Even assuming the Examiner is correct, the Applicant respectfully traverses the rejection on the basis that significant claim features and limitations are still missing from Roseman.

Claim 37, for example, can be distinguished from Roseman by the fact that it uses a **gaming machine** to generate random game outcomes that are subsequently relayed to a **gaming site**. The claim presently states "...said outcome data being generated by the **gaming machine** at said gaming establishment and relayed to said **gaming site**." The outcomes are then received by remote terminals that have accessed the gaming site. Thus, Claim 37 requires a **gaming machine** that is a separate element from the **gaming site**.

Roseman, in contrast, does not use a gaming machine to generate the random outcomes. Instead, Roseman uses a gaming server that provides web pages to a plurality of

clients terminals (see, e.g., col. 5, lines 12-23). In this regard, the Roseman gaming server essentially functions as a gaming site. Therefore, to the extent the Roseman gaming server may be considered a “gaming machine,” as urged by the Examiner, the Roseman “gaming machine” and the Roseman gaming site are one and the same. Consequently, Roseman is missing a fundamental limitation included in independent Claim 37, i.e., a **gaming machine** that is a separate element from the **gaming site**.

Claim 38 can also be distinguished from Roseman by its use of a gaming machine that is separate from a gaming site. In addition, Claim 38 states “...generating outcome data at a **gaming machine** communicatively coupled to said **gaming server**...” Thus, the **gaming server** in Claim 38 is also a separate element from the **gaming machine**. To the extent the Roseman gaming server may be considered a “gaming machine,” as urged by the Examiner, the gaming server and the “gaming machine” would not be separate elements.

Accordingly, for at least the reasons stated above, withdrawal of the rejection against Claims 37 and 38 over Roseman is respectfully requested.

**Claim Rejections Over Wiltshire In View Of Walker - 35 U.S.C. § 103(a)**

Claims 37-62 were rejected under 35 U.S.C. § 103(a) as being unpatentable over U.S. Patent No. 6,001,016 to Walker (“Walker”) in view of U.S. Patent No. 6,409,602 to Wiltshire (“Wiltshire”). The Examiner alleges that Walker discloses the claimed invention except that:

Walker does not expressly disclose the communication link between the remote terminal and a gaming site on a global computer network (Internet) and receiving text or graphical outcome data at the remote terminal for the selected game as recited in claims 37-39, 52, and 62; the game outcome results from the server initiating game play on the selected gaming machine as recited in claim 50; the outcome results from the manual game play on the selected gaming machine as recited in claim 51; receiving information includes receiving information selecting at least two plurality of local gaming machines for remote play as recited in claim 54. Office Action, page 4, lines 13-19.

The Examiner contends, however, that Wiltshire teaches these aspects of the claimed invention, and that it would have been obvious to one of ordinary skill in the art at the time the invention was made to modify Walker with the teachings of Wiltshire in order to allow players to participate in different casino types games from a secure and tamperproof computer gaming system. Even assuming that there is motivation to combine Walker and Wiltshire, the Applicant

respectfully traverses the rejection on the basis that significant claim features and limitations are missing from the proposed combination.

For example, all of the independent claims (Claims 37-39, 52, and 62) recite a **gaming site** that is connected to or otherwise in communication with a **gaming server** (or the use of these elements). That is, the claims require a **gaming site** that is separate from the **gaming server**. The relevant portions of the claims are reproduced below for the Examiner's convenience. Note that Claim 62 is written in means-plus-function form and must be construed to cover the corresponding structures disclosed in the specification, including the **gaming site** and the **gaming server**. 35 U.S.C. § 112, ¶ 6.

Claim 37: "...receiving randomly-generated text or graphical outcome data at said remote terminal for said selected game, said outcome data being generated by the gaming machine at said gaming establishment and relayed to said **gaming site** through a **gaming server** connected to said gaming site."

Claim 38: "...transmitting said outcome data from said **gaming server** to said **gaming site** for display to said player on said remote terminal in text or graphical form."

Claim 39: "...said **gaming site** in communication with a **gaming server** for collecting outcome data from gaming machines located inside the gaming establishment..."

Claim 52 (preamble): "...said remote computer connected to a **gaming site** through a global computing network served by said **gaming server**..."

Claim 62: "...means for receiving a text or graphical outcome resulting from a play of said selected local gaming machines..."

In contrast, neither Walker nor Wiltshire discloses a **gaming site** that is separate from a **gaming server** (or the use of these elements). Walker merely discloses a server that is connected to multiple slot machines over a local area network (see, e.g., col. 3, lines 60-63; col. 4, lines 2-5; and Figure 1). Likewise, Wiltshire merely discloses a server that is connected to a plurality of remote clients machine via a network interface and communication pathways (see, e.g., col. 3, lines 61-66; and Figure 1D). Nowhere does Walker or Wiltshire (or any other art of

record), taken alone or in combination, disclose both a **gaming site** and a **gaming server** as elements, as recited in the independent claims.

Furthermore, all the independent claims expressly state that the remote terminal or remote computer is located **outside the gaming establishment**. In contrast, Walker appears to teach that the remote wagering terminal is located right there on the premises of the gaming establishment. For example, Walker teaches that “each” remote wagering terminal has a hopper for dispensing coins (see, e.g., col. 7, lines 54-56). Such a hopper would need to be maintained and refilled from time to time with an appropriate amount of coins. It would be extremely difficult to effect such maintenance unless the remote wagering terminal was located right there on the premises. This position is further supported by the statement in Walker that the player will be provided with a “map of all slots machines” (see, e.g., col. 9, lines 36-38). Such a map would only be useful if the player (hence, the remote wagering terminal) was right there on the premises.

As for Claims 40-51 and 53-61, although they recite independently allowable subject matter, these claims depend from independent Claims 37-39, 52, and 62, and are therefore allowable for at least the reasons stated above.

Accordingly, withdrawal of the rejection against Claims 37-62 over Walker in view of Wiltshire is respectively requested.

**CONCLUSION**

In view of the above, each of the presently pending claims in this application is believed to be in immediate condition for allowance. Accordingly, the Examiner is respectfully requested to pass this application to issue.

Dated:

Respectfully submitted,

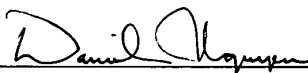
By 

Daniel G. Nguyen

Registration No.: 42,933

JENKENS & GILCHRIST, A PROFESSIONAL CORPORATION

225 W. Washington, Ste. 2600

Chicago, Illinois 60606-3418

(312) 425-3900

(312) 425-3909 (Fax)

Under the Paperwork Reduction Act of 1995, no persons are required to respond to a collection of information unless it displays a valid OMB control number.

<b>PETITION FOR EXTENSION OF TIME UNDER 37 CFR 1.136(a)</b>		Docket No. (Optional) 47079-00077USPT																
	In re Application of Shridhar P. Joshi																	
	Application Number 09/688501	Filed October 16, 2000																
	For: METHOD OF TRANSFERRING GAMING DATA ON A GLOBAL COMPUTER NETWORK																	
	Art Unit 3714	Examiner Alex P. Rada																
<p>This is a request under the provisions of 37 CFR 1.136(a) to extend the period for filing a reply in the above identified application.</p> <p>The requested extension and appropriate non-small-entity fee are as follows (check time period desired):</p> <table border="0"> <tr> <td><input checked="" type="checkbox"/> One month (37 CFR 1.17(a)(1))</td> <td>\$</td> <td>110.00</td> </tr> <tr> <td><input type="checkbox"/> Two months (37 CFR 1.17(a)(2))</td> <td>\$</td> <td></td> </tr> <tr> <td><input type="checkbox"/> Three months (37 CFR 1.17(a)(3))</td> <td>\$</td> <td></td> </tr> <tr> <td><input type="checkbox"/> Four months (37 CFR 1.17(a)(4))</td> <td>\$</td> <td></td> </tr> <tr> <td><input type="checkbox"/> Five months (37 CFR 1.17(a)(5))</td> <td>\$</td> <td></td> </tr> </table> <p><input type="checkbox"/> Applicant claims small entity status. See 37 CFR 1.27. Therefore, the fee amount shown above is reduced by one-half, and the resulting fee is: \$ _____</p> <p><input checked="" type="checkbox"/> A check in the amount of the fee is enclosed.</p> <p><input type="checkbox"/> Payment by credit card. Form PTO-2038 is attached.</p> <p><input type="checkbox"/> The Director has already been authorized to charge fees in this application to a Deposit Account.</p> <p><input checked="" type="checkbox"/> The Director is hereby authorized to charge any fees which may be required, or credit any overpayment, to Deposit Account Number <u>10-0447</u></p> <p>I have enclosed a duplicate copy of this sheet.</p> <p>I am the <input type="checkbox"/> applicant/inventor.  <input type="checkbox"/> assignee of record of the entire interest. See 37 CFR 3.71.  Statement under 37 CFR 3.73(b) is enclosed. (Form PTO/SB/96).  <input type="checkbox"/> attorney or agent of record. Registration Number _____  <input checked="" type="checkbox"/> attorney or agent under 37 CFR 1.34(a).  Registration number if acting under 37 CFR 1.34(a) <u>42,933</u></p> <p><u>March 18, 2004</u> Date</p> <p><u>(713) 951-3354</u> Telephone Number</p> <p><u>Daniel Nguyen</u> Signature</p> <p><u>Daniel G. Nguyen</u> Typed or printed name</p> <p>NOTE: Signatures of all the inventors or assignees of record of the entire interest or their representative(s) are required. Submit multiple forms if more than one signature is required, see below</p>				<input checked="" type="checkbox"/> One month (37 CFR 1.17(a)(1))	\$	110.00	<input type="checkbox"/> Two months (37 CFR 1.17(a)(2))	\$		<input type="checkbox"/> Three months (37 CFR 1.17(a)(3))	\$		<input type="checkbox"/> Four months (37 CFR 1.17(a)(4))	\$		<input type="checkbox"/> Five months (37 CFR 1.17(a)(5))	\$	
<input checked="" type="checkbox"/> One month (37 CFR 1.17(a)(1))	\$	110.00																
<input type="checkbox"/> Two months (37 CFR 1.17(a)(2))	\$																	
<input type="checkbox"/> Three months (37 CFR 1.17(a)(3))	\$																	
<input type="checkbox"/> Four months (37 CFR 1.17(a)(4))	\$																	
<input type="checkbox"/> Five months (37 CFR 1.17(a)(5))	\$																	
<input type="checkbox"/> Total of <u>1</u> forms are submitted.																		

**RECEIVED**  
MAR 30 2004  
TECHNOLOGY CENTER R3700

I hereby certify that this correspondence is being deposited with the U.S. Postal Service with sufficient postage as First Class Mail, in an envelope addressed to: Commissioner for Patents, P.O. Box 1450, Alexandria, VA 22313-1450, on the date shown below.

Dated: March 18, 2004      Signature: Susan B. Jensen (Susan B. Jensen)

03/23/2004 JAD001 00000662 09688501 110.00 DP  
01 FC:1251



3714/18

PTO/SB/21 (08-03)  
 Approved for use through 07/31/2008. OMB 0651-0031  
 U.S. Patent and Trademark Office: U.S. DEPARTMENT OF COMMERCE  
 Under the Paperwork Reduction Act of 1995, no persons are required to respond to a collection of information unless it displays a valid OMB control number.

<b>TRANSMITTAL FORM</b> <small>(to be used for all correspondence after initial filing)</small>	Application Number	09/688501	
	Filing Date	October 16, 2000	
	First Named Inventor	Shridhar P. Joshi	
	Art Unit	3714	
	Examiner Name	Alex P. Rada	
Total Number of Pages in This Submission	23	Attorney Docket Number	47079-00077USPT

ENCLOSURES (Check all that apply)		
<input checked="" type="checkbox"/> Fee Transmittal Form <input checked="" type="checkbox"/> Fee Attached <input checked="" type="checkbox"/> Amendment/Reply <input type="checkbox"/> After Final <input type="checkbox"/> Affidavits/declaration(s) <input checked="" type="checkbox"/> Extension of Time Request <input type="checkbox"/> Express Abandonment Request <input type="checkbox"/> Information Disclosure Statement <input type="checkbox"/> Certified Copy of Priority Document(s) <input type="checkbox"/> Response to Missing Parts/Incomplete Application <input type="checkbox"/> Response to Missing Parts under 37 CFR 1.52 or 1.53	<input type="checkbox"/> Drawing(s) <input type="checkbox"/> Licensing-related Papers <input type="checkbox"/> Petition <input type="checkbox"/> Petition to Convert to a Provisional Application <input type="checkbox"/> Power of Attorney, Revocation Change of Correspondence Address <input type="checkbox"/> Terminal Disclaimer <input type="checkbox"/> Request for Refund <input type="checkbox"/> CD, Number of CD(s) _____	<input type="checkbox"/> After Allowance Communication to Group <input type="checkbox"/> Appeal Communication to Board of Appeals and Interferences <input type="checkbox"/> Appeal Communication to Group (Appeal Notice, Brief, Reply Brief) <input type="checkbox"/> Proprietary Information <input type="checkbox"/> Status Letter <input checked="" type="checkbox"/> Other Enclosure(s) (please identify below): Postcard Check for \$110 #158088 Certificate of Mailing 1.8
Remarks		<b>RECEIVED</b> MAR 30 2004 TECHNOLOGY CENTER R3700

SIGNATURE OF APPLICANT, ATTORNEY, OR AGENT	
Firm or Individual name	JENKENS & GILCHRIST, A PROFESSIONAL CORPORATION Daniel G. Nguyen Reg. No. 42,933
Signature	<i>Daniel Nguyen</i>
Date	March 18, 2004

HOUSTON 305033v1 47079-00077



Under the Paperwork Reduction Act of 1995, no persons are required to respond to a collection of information unless it displays a valid OMB control number.

<h1 style="text-align: center;">FEE TRANSMITTAL</h1> <h2 style="text-align: center;">for FY 2004</h2> <p style="text-align: center; font-size: small;">Effective 10/01/2003, Patent fees are subject to annual revision.</p>		<b>Complete if Known</b>	
		Application Number	09/688501
		Filing Date	October 16, 2000
		First Named Inventor	Shridhar P. Joshi
		Examiner Name	Alex P. Rada
		Art Unit	3714
		Attorney Docket No.	47079-00077USPT
<input type="checkbox"/> Applicant claims small entity status. See 37 CFR 1.27			
<b>TOTAL AMOUNT OF PAYMENT</b> (\$) <b>110.00</b>			

<b>METHOD OF PAYMENT</b> (check all that apply)		<b>FEE CALCULATION</b> (continued)																																																																																																																																																																																																	
<input checked="" type="checkbox"/> Check <input type="checkbox"/> Credit Card <input type="checkbox"/> Money Order <input type="checkbox"/> Other <input type="checkbox"/> None		<b>3. ADDITIONAL FEES</b>																																																																																																																																																																																																	
<input type="checkbox"/> Deposit Account: Deposit Account Number: 10-0447 Deposit Account Name: Jenkens & Gilchrist, a Professional Corporation The Director is authorized to: (check all that apply) <input type="checkbox"/> Charge fee(s) indicated below <input checked="" type="checkbox"/> Credit any overpayments <input checked="" type="checkbox"/> Charge any additional fee(s) or any underpayment of fee(s) <input type="checkbox"/> Charge fee(s) indicated below, except for the filing fee to the above-identified deposit account.		<table border="1"> <thead> <tr> <th colspan="2">Large Entity</th> <th colspan="2">Small Entity</th> <th rowspan="2">Fee Description</th> <th rowspan="2">Fee Paid</th> </tr> <tr> <th>Fee Code</th> <th>Fee (\$)</th> <th>Fee Code</th> <th>Fee (\$)</th> </tr> </thead> <tbody> <tr><td>1051</td><td>130</td><td>2051</td><td>65</td><td>Surcharge - late filing fee or oath</td><td></td></tr> <tr><td>1052</td><td>50</td><td>2052</td><td>25</td><td>Surcharge - late provisional filing fee or cover sheet.</td><td></td></tr> <tr><td>1053</td><td>130</td><td>1053</td><td>130</td><td>Non-English specification</td><td></td></tr> <tr><td>1812</td><td>2,520</td><td>1812</td><td>2,520</td><td>For filing a request for <i>ex parte</i> reexamination</td><td></td></tr> <tr><td>1804</td><td>920*</td><td>1804</td><td>920*</td><td>Requesting publication of SIR prior to Examiner action</td><td></td></tr> <tr><td>1805</td><td>1,840*</td><td>1805</td><td>1,840*</td><td>Requesting publication of SIR after Examiner action</td><td></td></tr> <tr><td>1251</td><td>110</td><td>2251</td><td>55</td><td>Extension for reply within first month</td><td>110.00</td></tr> <tr><td>1252</td><td>420</td><td>2252</td><td>210</td><td>Extension for reply within second month</td><td></td></tr> <tr><td>1253</td><td>950</td><td>2253</td><td>475</td><td>Extension for reply within third month</td><td></td></tr> <tr><td>1254</td><td>1,480</td><td>2254</td><td>740</td><td>Extension for reply within fourth month</td><td></td></tr> <tr><td>1255</td><td>2,010</td><td>2255</td><td>1,005</td><td>Extension for reply within fifth month</td><td></td></tr> <tr><td>1401</td><td>330</td><td>2401</td><td>165</td><td>Notice of Appeal</td><td></td></tr> <tr><td>1402</td><td>330</td><td>2402</td><td>165</td><td>Filing a brief in support of an appeal</td><td></td></tr> <tr><td>1403</td><td>290</td><td>2403</td><td>145</td><td>Request for oral hearing</td><td></td></tr> <tr><td>1451</td><td>1,510</td><td>1451</td><td>1,510</td><td>Petition to institute a public use proceeding</td><td></td></tr> <tr><td>1452</td><td>110</td><td>2452</td><td>55</td><td>Petition to revive - unavoidable</td><td></td></tr> <tr><td>1453</td><td>1,330</td><td>2453</td><td>665</td><td>Petition to revive - unintentional</td><td></td></tr> <tr><td>1501</td><td>1,330</td><td>2501</td><td>665</td><td>Utility issue fee (or reissue)</td><td></td></tr> <tr><td>1502</td><td>480</td><td>2502</td><td>240</td><td>Design issue fee</td><td></td></tr> <tr><td>1503</td><td>640</td><td>2503</td><td>320</td><td>Plant issue fee</td><td></td></tr> <tr><td>1460</td><td>130</td><td>1460</td><td>130</td><td>Petitions to the Commissioner</td><td></td></tr> <tr><td>1807</td><td>50</td><td>1807</td><td>50</td><td>Processing fee under 37 CFR 1.17(q)</td><td></td></tr> <tr><td>1806</td><td>180</td><td>1806</td><td>180</td><td>Submission of Information Disclosure Stmt</td><td></td></tr> <tr><td>8021</td><td>40</td><td>8021</td><td>40</td><td>Recording each patent assignment per property (times number of properties)</td><td></td></tr> <tr><td>1809</td><td>770</td><td>2809</td><td>385</td><td>Filing a submission after final rejection (37 CFR 1.129(a))</td><td></td></tr> <tr><td>1810</td><td>770</td><td>2810</td><td>385</td><td>For each additional invention to be examined (37 CFR 1.129(b))</td><td></td></tr> <tr><td>1801</td><td>770</td><td>2801</td><td>385</td><td>Request for Continued Examination (RCE)</td><td></td></tr> <tr><td>1802</td><td>900</td><td>1802</td><td>900</td><td>Request for expedited examination of a design application</td><td></td></tr> <tr><td colspan="6">Other fee (specify) _____</td></tr> <tr> <td colspan="2"> <b>SUBTOTAL (1)</b> (\$) <b>0.00</b> </td> <td colspan="2"> <b>SUBTOTAL (3)</b> (\$) <b>110.00</b> </td> <td colspan="2"></td> </tr> </tbody> </table>				Large Entity		Small Entity		Fee Description	Fee Paid	Fee Code	Fee (\$)	Fee Code	Fee (\$)	1051	130	2051	65	Surcharge - late filing fee or oath		1052	50	2052	25	Surcharge - late provisional filing fee or cover sheet.		1053	130	1053	130	Non-English specification		1812	2,520	1812	2,520	For filing a request for <i>ex parte</i> reexamination		1804	920*	1804	920*	Requesting publication of SIR prior to Examiner action		1805	1,840*	1805	1,840*	Requesting publication of SIR after Examiner action		1251	110	2251	55	Extension for reply within first month	110.00	1252	420	2252	210	Extension for reply within second month		1253	950	2253	475	Extension for reply within third month		1254	1,480	2254	740	Extension for reply within fourth month		1255	2,010	2255	1,005	Extension for reply within fifth month		1401	330	2401	165	Notice of Appeal		1402	330	2402	165	Filing a brief in support of an appeal		1403	290	2403	145	Request for oral hearing		1451	1,510	1451	1,510	Petition to institute a public use proceeding		1452	110	2452	55	Petition to revive - unavoidable		1453	1,330	2453	665	Petition to revive - unintentional		1501	1,330	2501	665	Utility issue fee (or reissue)		1502	480	2502	240	Design issue fee		1503	640	2503	320	Plant issue fee		1460	130	1460	130	Petitions to the Commissioner		1807	50	1807	50	Processing fee under 37 CFR 1.17(q)		1806	180	1806	180	Submission of Information Disclosure Stmt		8021	40	8021	40	Recording each patent assignment per property (times number of properties)		1809	770	2809	385	Filing a submission after final rejection (37 CFR 1.129(a))		1810	770	2810	385	For each additional invention to be examined (37 CFR 1.129(b))		1801	770	2801	385	Request for Continued Examination (RCE)		1802	900	1802	900	Request for expedited examination of a design application		Other fee (specify) _____						<b>SUBTOTAL (1)</b> (\$) <b>0.00</b>		<b>SUBTOTAL (3)</b> (\$) <b>110.00</b>			
Large Entity		Small Entity		Fee Description	Fee Paid																																																																																																																																																																																														
Fee Code	Fee (\$)	Fee Code	Fee (\$)																																																																																																																																																																																																
1051	130	2051	65	Surcharge - late filing fee or oath																																																																																																																																																																																															
1052	50	2052	25	Surcharge - late provisional filing fee or cover sheet.																																																																																																																																																																																															
1053	130	1053	130	Non-English specification																																																																																																																																																																																															
1812	2,520	1812	2,520	For filing a request for <i>ex parte</i> reexamination																																																																																																																																																																																															
1804	920*	1804	920*	Requesting publication of SIR prior to Examiner action																																																																																																																																																																																															
1805	1,840*	1805	1,840*	Requesting publication of SIR after Examiner action																																																																																																																																																																																															
1251	110	2251	55	Extension for reply within first month	110.00																																																																																																																																																																																														
1252	420	2252	210	Extension for reply within second month																																																																																																																																																																																															
1253	950	2253	475	Extension for reply within third month																																																																																																																																																																																															
1254	1,480	2254	740	Extension for reply within fourth month																																																																																																																																																																																															
1255	2,010	2255	1,005	Extension for reply within fifth month																																																																																																																																																																																															
1401	330	2401	165	Notice of Appeal																																																																																																																																																																																															
1402	330	2402	165	Filing a brief in support of an appeal																																																																																																																																																																																															
1403	290	2403	145	Request for oral hearing																																																																																																																																																																																															
1451	1,510	1451	1,510	Petition to institute a public use proceeding																																																																																																																																																																																															
1452	110	2452	55	Petition to revive - unavoidable																																																																																																																																																																																															
1453	1,330	2453	665	Petition to revive - unintentional																																																																																																																																																																																															
1501	1,330	2501	665	Utility issue fee (or reissue)																																																																																																																																																																																															
1502	480	2502	240	Design issue fee																																																																																																																																																																																															
1503	640	2503	320	Plant issue fee																																																																																																																																																																																															
1460	130	1460	130	Petitions to the Commissioner																																																																																																																																																																																															
1807	50	1807	50	Processing fee under 37 CFR 1.17(q)																																																																																																																																																																																															
1806	180	1806	180	Submission of Information Disclosure Stmt																																																																																																																																																																																															
8021	40	8021	40	Recording each patent assignment per property (times number of properties)																																																																																																																																																																																															
1809	770	2809	385	Filing a submission after final rejection (37 CFR 1.129(a))																																																																																																																																																																																															
1810	770	2810	385	For each additional invention to be examined (37 CFR 1.129(b))																																																																																																																																																																																															
1801	770	2801	385	Request for Continued Examination (RCE)																																																																																																																																																																																															
1802	900	1802	900	Request for expedited examination of a design application																																																																																																																																																																																															
Other fee (specify) _____																																																																																																																																																																																																			
<b>SUBTOTAL (1)</b> (\$) <b>0.00</b>		<b>SUBTOTAL (3)</b> (\$) <b>110.00</b>																																																																																																																																																																																																	
<b>1. BASIC FILING FEE</b> <table border="1"> <thead> <tr> <th colspan="2">Large Entity</th> <th colspan="2">Small Entity</th> <th rowspan="2">Fee Description</th> <th rowspan="2">Fee Paid</th> </tr> <tr> <th>Fee Code</th> <th>Fee (\$)</th> <th>Fee Code</th> <th>Fee (\$)</th> </tr> </thead> <tbody> <tr><td>1001</td><td>770</td><td>2001</td><td>385</td><td>Utility filing fee</td><td></td></tr> <tr><td>1002</td><td>340</td><td>2002</td><td>170</td><td>Design filing fee</td><td></td></tr> <tr><td>1003</td><td>530</td><td>2003</td><td>265</td><td>Plant filing fee</td><td></td></tr> <tr><td>1004</td><td>770</td><td>2004</td><td>385</td><td>Reissue filing fee</td><td></td></tr> <tr><td>1005</td><td>160</td><td>2005</td><td>80</td><td>Provisional filing fee</td><td></td></tr> <tr><td colspan="6"><b>SUBTOTAL (1)</b> (\$) <b>0.00</b></td></tr> </tbody> </table>		Large Entity		Small Entity		Fee Description	Fee Paid	Fee Code	Fee (\$)	Fee Code	Fee (\$)	1001	770	2001	385	Utility filing fee		1002	340	2002	170	Design filing fee		1003	530	2003	265	Plant filing fee		1004	770	2004	385	Reissue filing fee		1005	160	2005	80	Provisional filing fee		<b>SUBTOTAL (1)</b> (\$) <b>0.00</b>																																																																																																																																																									
Large Entity		Small Entity		Fee Description	Fee Paid																																																																																																																																																																																														
Fee Code	Fee (\$)	Fee Code	Fee (\$)																																																																																																																																																																																																
1001	770	2001	385	Utility filing fee																																																																																																																																																																																															
1002	340	2002	170	Design filing fee																																																																																																																																																																																															
1003	530	2003	265	Plant filing fee																																																																																																																																																																																															
1004	770	2004	385	Reissue filing fee																																																																																																																																																																																															
1005	160	2005	80	Provisional filing fee																																																																																																																																																																																															
<b>SUBTOTAL (1)</b> (\$) <b>0.00</b>																																																																																																																																																																																																			
<b>2. EXTRA CLAIM FEES FOR UTILITY AND REISSUE</b> <table border="1"> <thead> <tr> <th colspan="2">Large Entity</th> <th colspan="2">Small Entity</th> <th rowspan="2">Fee Description</th> <th rowspan="2">Fee Paid</th> </tr> <tr> <th>Fee Code</th> <th>Fee (\$)</th> <th>Fee Code</th> <th>Fee (\$)</th> </tr> </thead> <tbody> <tr><td>1202</td><td>18</td><td>2202</td><td>9</td><td>Claims in excess of 20</td><td></td></tr> <tr><td>1201</td><td>86</td><td>2201</td><td>43</td><td>Independent claims in excess of 3</td><td></td></tr> <tr><td>1203</td><td>290</td><td>2203</td><td>145</td><td>Multiple dependent claim, if not paid</td><td></td></tr> <tr><td>1204</td><td>86</td><td>2204</td><td>43</td><td>** Reissue independent claims over original patent</td><td></td></tr> <tr><td>1205</td><td>18</td><td>2205</td><td>9</td><td>** Reissue claims in excess of 20 and over original patent</td><td></td></tr> <tr><td colspan="6"><b>SUBTOTAL (2)</b> (\$) <b>0.00</b></td></tr> </tbody> </table>		Large Entity		Small Entity		Fee Description	Fee Paid	Fee Code	Fee (\$)	Fee Code	Fee (\$)	1202	18	2202	9	Claims in excess of 20		1201	86	2201	43	Independent claims in excess of 3		1203	290	2203	145	Multiple dependent claim, if not paid		1204	86	2204	43	** Reissue independent claims over original patent		1205	18	2205	9	** Reissue claims in excess of 20 and over original patent		<b>SUBTOTAL (2)</b> (\$) <b>0.00</b>																																																																																																																																																									
Large Entity		Small Entity		Fee Description	Fee Paid																																																																																																																																																																																														
Fee Code	Fee (\$)	Fee Code	Fee (\$)																																																																																																																																																																																																
1202	18	2202	9	Claims in excess of 20																																																																																																																																																																																															
1201	86	2201	43	Independent claims in excess of 3																																																																																																																																																																																															
1203	290	2203	145	Multiple dependent claim, if not paid																																																																																																																																																																																															
1204	86	2204	43	** Reissue independent claims over original patent																																																																																																																																																																																															
1205	18	2205	9	** Reissue claims in excess of 20 and over original patent																																																																																																																																																																																															
<b>SUBTOTAL (2)</b> (\$) <b>0.00</b>																																																																																																																																																																																																			

<b>SUBMITTED BY</b>		(Complete if applicable)	
Name (Print/Type)	Daniel G. Nguyen	Registration No. (Attorney/Agent)	42,933
Signature	<i>Daniel Nguyen</i>	Telephone	(713) 951-3354
		Date	March 18, 2004

RECEIVED

MAR 30 2004

TECHNOLOGY CENTER R3700





Under the Paperwork Reduction Act of 1995, no persons are required to respond to a collection of information unless it displays a valid OMB control number.  
Application No. (if known): 09/688501 Attorney Docket No.: 47079-00077USPT

### Certificate of Mailing Under 37 CFR 1.8

I hereby certify that this correspondence is being deposited with the United States Postal Service with sufficient postage as first class mail in an envelope addressed to:

Commissioner for Patents  
P.O. Box 1450  
Alexandria, VA 22313-1450

on March 18, 2004  
Date

RECEIVED

MAR 30 2004

TECHNOLOGY CENTER R3700

  
Signature

Susan B. Jensen

Typed or printed name of person signing Certificate

Note: Each paper must have its own certificate of mailing, or this certificate must identify each submitted paper.

- One Month Request for Extension of Time Under 37 CFR 1.136(a) (1 page)
- First Preliminary Amendment (16 pages)
- Amendment Transmittal (1 page)
- Transmittal (1 page)
- Fee Transmittal (1 page)
- Check in the amount of \$110.00 #158088



UNITED STATES PATENT AND TRADEMARK OFFICE

UNITED STATES DEPARTMENT OF COMMERCE  
United States Patent and Trademark Office  
Address: COMMISSIONER FOR PATENTS  
P.O. Box 1450  
Alexandria, Virginia 22313-1450  
www.uspto.gov

*SW*

APPLICATION NO.	FILING DATE	FIRST NAMED INVENTOR	ATTORNEY DOCKET NO.	CONFIRMATION NO.
-----------------	-------------	----------------------	---------------------	------------------

09/688,501	10/16/2000	Shridhar P. Joshi	47079-00077	3225
------------	------------	-------------------	-------------	------

30223 7590 06/16/2004  
**JENKENS & GILCHRIST, P.C.**  
 225 WEST WASHINGTON  
 SUITE 2600  
 CHICAGO, IL 60606

EXAMINER

RADA, ALEX P

ART UNIT PAPER NUMBER

3714

DATE MAILED: 06/16/2004

Please find below and/or attached an Office communication concerning this application or proceeding.

<b>Office Action Summary</b>	<b>Application No.</b>	<b>Applicant(s)</b>	
	09/688,501	JOSHI, SHRIDHAR P.	
	<b>Examiner</b>	<b>Art Unit</b>	
	Alex P. Rada	3714	

-- The MAILING DATE of this communication appears on the cover sheet with the correspondence address --

**Period for Reply**

A SHORTENED STATUTORY PERIOD FOR REPLY IS SET TO EXPIRE 3 MONTH(S) FROM THE MAILING DATE OF THIS COMMUNICATION.

- Extensions of time may be available under the provisions of 37 CFR 1.136(a). In no event, however, may a reply be timely filed after SIX (6) MONTHS from the mailing date of this communication.
- If the period for reply specified above is less than thirty (30) days, a reply within the statutory minimum of thirty (30) days will be considered timely.
- If NO period for reply is specified above, the maximum statutory period will apply and will expire SIX (6) MONTHS from the mailing date of this communication.
- Failure to reply within the set or extended period for reply will, by statute, cause the application to become ABANDONED (35 U.S.C. § 133). Any reply received by the Office later than three months after the mailing date of this communication, even if timely filed, may reduce any earned patent term adjustment. See 37 CFR 1.704(b).

**Status**

- 1)  Responsive to communication(s) filed on 22 March 2004.
- 2a)  This action is FINAL.
- 2b)  This action is non-final.
- 3)  Since this application is in condition for allowance except for formal matters, prosecution as to the merits is closed in accordance with the practice under *Ex parte Quayle*, 1935 C.D. 11, 453 O.G. 213.

**Disposition of Claims**

- 4)  Claim(s) 37-62 is/are pending in the application.
  - 4a) Of the above claim(s) \_\_\_\_\_ is/are withdrawn from consideration.
- 5)  Claim(s) \_\_\_\_\_ is/are allowed.
- 6)  Claim(s) 37-62 is/are rejected.
- 7)  Claim(s) \_\_\_\_\_ is/are objected to.
- 8)  Claim(s) \_\_\_\_\_ are subject to restriction and/or election requirement.

**Application Papers**

- 9)  The specification is objected to by the Examiner.
- 10)  The drawing(s) filed on \_\_\_\_\_ is/are: a)  accepted or b)  objected to by the Examiner.  
Applicant may not request that any objection to the drawing(s) be held in abeyance. See 37 CFR 1.85(a).  
Replacement drawing sheet(s) including the correction is required if the drawing(s) is objected to. See 37 CFR 1.121(d).
- 11)  The oath or declaration is objected to by the Examiner. Note the attached Office Action or form PTO-152.

**Priority under 35 U.S.C. § 119**

- 12)  Acknowledgment is made of a claim for foreign priority under 35 U.S.C. § 119(a)-(d) or (f).
  - a)  All    b)  Some \*    c)  None of:
  - 1.  Certified copies of the priority documents have been received.
  - 2.  Certified copies of the priority documents have been received in Application No. \_\_\_\_\_.
  - 3.  Copies of the certified copies of the priority documents have been received in this National Stage application from the International Bureau (PCT Rule 17.2(a)).

\* See the attached detailed Office action for a list of the certified copies not received.

**Attachment(s)**

- 1)  Notice of References Cited (PTO-892)
- 2)  Notice of Draftsperson's Patent Drawing Review (PTO-948)
- 3)  Information Disclosure Statement(s) (PTO-1449 or PTO/SB/08)  
Paper No(s)/Mail Date \_\_\_\_\_.
- 4)  Interview Summary (PTO-413)  
Paper No(s)/Mail Date. \_\_\_\_\_.
- 5)  Notice of Informal Patent Application (PTO-152)
- 6)  Other: \_\_\_\_\_.

## DETAILED ACTION

### *Response to Amendment*

In response to the amendment filed March 22, 2004 in which the applicant cancels claims 1-21 and 35-36, withdrawn claims 22-34, amends claims 37 and 62, and claims 37-62 are pending in this office action.

### *Claim Rejections - 35 USC § 103*

1. The following is a quotation of 35 U.S.C. 103(a) which forms the basis for all obviousness rejections set forth in this Office action:

(a) A patent may not be obtained though the invention is not identically disclosed or described as set forth in section 102 of this title, if the differences between the subject matter sought to be patented and the prior art are such that the subject matter as a whole would have been obvious at the time the invention was made to a person having ordinary skill in the art to which said subject matter pertains. Patentability shall not be negated by the manner in which the invention was made.

2. Claims 37 and 38 are rejected under 35 U.S.C. 103(a) as being unpatentable over Roseman '984 in view of Goldberg '366.

3. Roseman discloses the following:

Accessing via a remote terminal, a game site on a global computer network (internet) connected to the remote terminal, providing personal identification information to the gaming site, selecting a game of chance for remote play, placing a wager for playing the selected game, and receiving randomly-generated text or graphical outcome data at the remote terminal for the selected game (game server), in which the examiner interprets the selected game to be the game server being a game machine itself on a gaming site having a

plurality of games, and the outcome data being generated by the gaming machine (gaming server) and relayed to the gaming site as recited in claims 37 and 38.

Roseman does not expressly disclose the following:

A communication link between the remote terminal and a gaming site as recited in claims 37.

Goldberg teaches the following:

A communication link between the remote terminal (318) and a gaming site (308) as recited in claims 37. By having a communication link between the remote terminal and a gaming site, one of ordinary skill in the art would allow game players to participate in different casino type games from a secure gaming system.

Therefore, it would have been obvious to one of ordinary skill in the art at the time of the invention was made to modify Roseman to include communication link between the remote terminal and a gaming site as taught by Goldberg to allow game players to participate in different casino type games from a secure gaming system.

4. Claims 37-62 are rejected under 35 U.S.C. 103(a) as being unpatentable over Walker '016 in view of Goldberg and Wiltshire '602.

5. Walker discloses the following:

A communication link between the remote terminal and a gaming site, the gaming site in communication with a gaming server for outcome data from gaming machines located at a gaming establishment, selecting a gaming machine, making a wager to play the selected gaming machine, receiving outcome data

including game outcome at the remote terminal resulting from play of the gaming machine (column 2, lines 51-65), generating a payout, a microprocessor, and the memory connected to the microprocessor as recited in claims 37-39, 52, and 62.

The outcome data having information identifying the value of the payout and simulate a display of the game outcome at the remote location (column 5, lines 33-37) as recited in claims 40 and 59.

The outcome data to simulate a display of the game outcome on the remote terminal (column 5, lines 33-37) as recited in claim 41.

The selected gaming machine is a slot machine wherein the outcome data includes reel position (column 5, lines 33-37) as recited in claims 42, 48, 53, and 60.

The selected gaming machine is a video poker machine including a display for displaying a poker hand (column 5, lines 33-37) as recited in claims 43 and 58.

The receiving outcome data includes receiving outcome data from a plurality of gaming machine form remote play (column 6, lines 45-56) as recited in claim 44.

The outcome data includes a gaming machine identifier and gaming machine type (figure 5 and column 6, lines 31-44) as recited in claim 45-46 and 55-56.

The outcome data including receiving player preferences (column 6, lines 8-30) as recited in claims 47 and 57.

A player identifier and transmitting the player identifier for identification of the player (column 6, lines 8-30) as recited in claims 49 and 61.

Walker does not expressly disclose the following:

Communication link between the remote terminal and a gaming site on a global computer network (Internet) and receiving text or graphical outcome data at the remote terminal for the selected game as recited in claims 37-39, 52, and 62.

The game outcome results from the server initiating game play on the selected gaming machine as recited in claim 50.

The outcome results from the manual game play on the selected gaming machine as recited in claim 51.

Receiving information includes receiving information selecting at least two plurality of local gaming machines for remote play as recited in claim 54.

Goldberg teaches the following:

A communication link between the remote terminal (318) and a gaming site (308) as recited in claims 37-39, 52, and 62.

Wiltshire teaches the following:

Receiving text or graphical outcome data at the remote terminal from the selected game (column 7, lines 7-45) as recited in claim 37-39, 52, and 62.

The game outcome resulting from the server initiating game play on the selected gaming machine (column 8, lines 42-65) as recited in claim 50

The outcome results from the manual game play on the selected gaming machine, and receiving information includes receiving information selecting at least two plurality of local gaming machines for remote play (column 8, lines 42-65) as recited in claim 51. By having a communication link between the remote terminal and a gaming site on a global computer network (Internet) and receiving

text or graphical outcome data at the remote terminal for the selected game, one of ordinary skill in the art would allow game players to participate in different casino type games from a secure and tamper proof computer gaming system.

Therefore, it would have been obvious to one of ordinary skill in the art at the time of the invention was made to modify Walker to include a communication link between the remote terminal and a gaming site on a global computer network and receiving text or graphical outcome data at the remote terminal for the selected game, the game outcome resulting from the server initiating game play on the selected gaming machine, the outcome results from the manual game play on the selected gaming machine, and receiving information includes receiving information selecting at least two plurality of local gaming machines for remote play as taught by Goldberg and Wiltshire to allow game players to participate in different casino type games from a secure and tamper proof computer gaming system

### *Response to Arguments*

6. Applicant's arguments with respect to claims 37-62 have been considered but are moot in view of the new ground(s) of rejection.

### *Conclusion*

7. The prior art made of record and not relied upon is considered pertinent to applicant's disclosure.

Goldberg `560 and Vuong `552 disclose different types of network type games.



Application/Control Number: 09/688,501  
Art Unit: 3714

Page 7

Any inquiry concerning this communication or earlier communications from the examiner should be directed to Alex P. Rada whose telephone number is 703-308-7135. The examiner can normally be reached on Monday - Friday, 08:00-16:00.

If attempts to reach the examiner by telephone are unsuccessful, the examiner's primary, Jessica Harrison can be reached on 703-308-2217. The fax phone number for the organization where this application or proceeding is assigned is 703-872-9306.

Information regarding the status of an application may be obtained from the Patent Application Information Retrieval (PAIR) system. Status information for published applications may be obtained from either Private PAIR or Public PAIR. Status information for unpublished applications is available through Private PAIR only. For more information about the PAIR system, see <http://pair-direct.uspto.gov>. Should you have questions on access to the Private PAIR system, contact the Electronic Business Center (EBC) at 866-217-9197 (toll-free).

APR  
APR

  
JESSICA HARRISON  
PRIMARY EXAMINER

<b>Notice of References Cited</b>	Application/Control No. 09/688,501	Applicant(s)/Patent Under Reexamination JOSHI, SHRIDHAR P.	
	Examiner Alex P. Rada	Art Unit 3714	Page 1 of 1

**U.S. PATENT DOCUMENTS**

*	Document Number Country Code-Number-Kind Code	Date MM-YYYY	Name	Classification
A	US-5,762,552	06-1998	Vuong et al.	463/25
B	US-6,183,366	02-2001	Goldberg et al.	463/42
C	US-6,204,560	07-2001	Goldberg et al.	463/42
D	US-			
E	US-			
F	US-			
G	US-			
H	US-			
I	US-			
J	US-			
K	US-			
L	US-			
M	US-			

**FOREIGN PATENT DOCUMENTS**

*	Document Number Country Code-Number-Kind Code	Date MM-YYYY	Country	Name	Classification
N					
O					
P					
Q					
R					
S					
T					

**NON-PATENT DOCUMENTS**

*	Include as applicable: Author, Title Date, Publisher, Edition or Volume, Pertinent Pages)
U	
V	
W	
X	

\*A copy of this reference is not being furnished with this Office action. (See MPEP § 707.05(a).) Dates in MM-YYYY format are publication dates. Classifications may be US or foreign.

**Search Notes**



**Application No.**

09/688,501

**Examiner**

Alex P. Rada

**Applicant(s)**

JOSHI, SHRIDHAR P.

**Art Unit**

3714

**SEARCHED**

Class	Subclass	Date	Examiner
463	16-25 29,40-42	6/24/2004	APR

**SEARCH NOTES  
(INCLUDING SEARCH STRATEGY)**

	DATE	EXMR

**INTERFERENCE SEARCHED**

Class	Subclass	Date	Examiner

**Index of Claims**



Application No.

09/688,501

Examiner

Alex P. Rada

Applicant(s)

JOSHI, SHRIDHAR P.

Art Unit

3714

√	Rejected
=	Allowed

-	(Through numeral) Cancelled
+	Restricted

N	Non-Elected
I	Interference

A	Appeal
O	Objected

Claim		Date			
Final	Original	6/12/04			
1					
2					
3					
4					
5					
6					
7					
8					
9					
10					
11					
12					
13					
14					
15					
16					
17					
18					
19					
20					
21					
22					
23					
24					
25					
26					
27					
28					
29					
30					
31					
32					
33					
34					
35					
36					
37	√				
38	√				
39	√				
40	√				
41	√				
42	√				
43	√				
44	√				
45	√				
46	√				
47	√				
48	√				
49	√				
50	√				

Claim		Date			
Final	Original	6/12/04			
51	√				
52	√				
53	√				
54	√				
55	√				
56	√				
57	√				
58	√				
59	√				
60	√				
61	√				
62	√				
63					
64					
65					
66					
67					
68					
69					
70					
71					
72					
73					
74					
75					
76					
77					
78					
79					
80					
81					
82					
83					
84					
85					
86					
87					
88					
89					
90					
91					
92					
93					
94					
95					
96					
97					
98					
99					
100					

Claim		Date			
Final	Original				
101					
102					
103					
104					
105					
106					
107					
108					
109					
110					
111					
112					
113					
114					
115					
116					
117					
118					
119					
120					
121					
122					
123					
124					
125					
126					
127					
128					
129					
130					
131					
132					
133					
134					
135					
136					
137					
138					
139					
140					
141					
142					
143					
144					
145					
146					
147					
148					
149					
150					

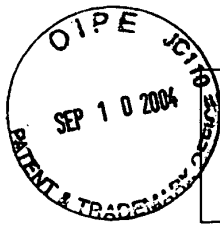

3225  
Cfu

I hereby certify that this correspondence is being deposited with the U.S. Postal Service with sufficient postage as First Class Mail, in an envelope addressed to: MS Amendment, Commissioner for Patents, P.O. Box 1450, Alexandria, VA 22313-1450, on the date shown below.  
Dated: September 8, 2004 Signature: *Susan B. Jensen*  
(Susan B. Jensen)

Docket No.: 47079-00077USPT  
(PATENT)

**IN THE UNITED STATES PATENT AND TRADEMARK OFFICE**

In re Patent Application of:  
Shridhar P. Joshi

Application No.: 09/688501

Art Unit: 3225

Filed: October 16, 2000

Examiner: Alex P. Rada

For: METHOD OF TRANSFERRING GAMING  
DATA ON A GLOBAL COMPUTER  
NETWORK

**AMENDMENT IN RESPONSE TO NON-FINAL OFFICE ACTION**

MS Amendment  
Commissioner for Patents  
P.O. Box 1450  
Alexandria, VA 22313-1450

Dear Sir:

**INTRODUCTORY COMMENTS**

In response to the Office Action dated June 16, 2004, please amend the above-identified U.S. patent application as follows:

**Amendments to the Claims** are reflected in the listing of claims which begins on page 2 of this paper.

**Remarks/Arguments** begin on page 7 of this paper.

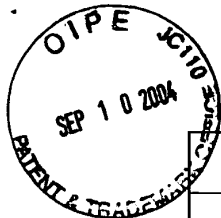

**AMENDMENT TRANSMITTAL LETTER**

Docket No.  
47079-00077USPT

Application No. 09/688501	Filing Date October 16, 2000	Examiner Alex P. Rada	Art Unit 3225
------------------------------	---------------------------------	--------------------------	------------------

Applicant(s): Shridhar P. Joshi

Invention: METHOD OF TRANSFERRING GAMING DATA ON A GLOBAL COMPUTER NETWORK

**TO THE COMMISSIONER FOR PATENTS**

Transmitted herewith is an amendment in the above-identified application.

The fee has been calculated and is transmitted as shown below.

CLAIMS AS AMENDED					
	Claims Remaining After Amendment	Highest Number Previously Paid	Number Extra Claims Present	Rate	
Total Claims	62	- 62 =	0	x	0.00
Independent Claims	5	- 8 =	0	x	0.00
Multiple Dependent Claims (check if applicable) <input type="checkbox"/>					
Other fee (please specify):					
<b>TOTAL ADDITIONAL FEE FOR THIS AMENDMENT:</b>					<b>0.00</b>

- Large Entity  Small Entity
- No additional fee is required for this amendment.
- Please charge Deposit Account No. \_\_\_\_\_ in the amount of \$ \_\_\_\_\_.  
A duplicate copy of this sheet is enclosed.
- A check in the amount of \$ \_\_\_\_\_ to cover the filing fee is enclosed.
- Payment by credit card. Form PTO-2038 is attached.
- The Director is hereby authorized to charge and credit Deposit Account No. 10-0447  
as described below.
- Credit any overpayment.
- Charge any additional filing or application processing fees required under 37 CFR 1.16 and 1.17.

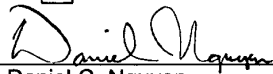
  
 Daniel G. Nguyen  
 Attorney Reg. No.: 42,933  
 JENKENS & GILCHRIST, A PROFESSIONAL CORPORATION  
 225 W. Washington, Ste. 2600  
 Chicago, Illinois 60606-3418  
 (713) 951-3354

Dated: September 8, 2004

I hereby certify that this correspondence is being deposited with the U.S. Postal Service with sufficient postage as First Class Mail, in an envelope addressed to: MS Amendment, Commissioner for Patents, P.O. Box 1450, Alexandria, VA 22313-1450, on the date shown below.

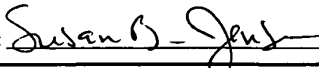
Dated: September 8, 2004      Signature:  (Susan B. Jensen)



PTO/SB/21 (04-04)

Approved for use through 07/31/2006. OMB 0651-0031

U.S. Patent and Trademark Office; U.S. DEPARTMENT OF COMMERCE

Under the Paperwork Reduction Act of 1995, no persons are required to respond to a collection of information unless it displays a valid OMB control number.

<h1>TRANSMITTAL FORM</h1> <p><i>(to be used for all correspondence after initial filing)</i></p>		Application Number	09/688501
		Filing Date	October 16, 2000
		First Named Inventor	Shridhar P. Joshi
		Art Unit	3225
		Examiner Name	Alex P. Rada
Total Number of Pages in This Submission	13	Attorney Docket Number	47079-00077USPT

ENCLOSURES (Check all that apply)		
<input type="checkbox"/> Fee Transmittal Form <input type="checkbox"/> Fee Attached <input checked="" type="checkbox"/> Amendment/Reply <input type="checkbox"/> After Final <input type="checkbox"/> Affidavits/declaration(s) <input type="checkbox"/> Extension of Time Request <input type="checkbox"/> Express Abandonment Request <input type="checkbox"/> Information Disclosure Statement <input type="checkbox"/> Certified Copy of Priority Document(s) <input type="checkbox"/> Response to Missing Parts/ Incomplete Application <input type="checkbox"/> Response to Missing Parts under 37 CFR 1.52 or 1.53	<input type="checkbox"/> Drawing(s) <input type="checkbox"/> Licensing-related Papers <input type="checkbox"/> Petition <input type="checkbox"/> Petition to Convert to a Provisional Application <input type="checkbox"/> Power of Attorney, Revocation Change of Correspondence Address <input type="checkbox"/> Terminal Disclaimer <input type="checkbox"/> Request for Refund <input type="checkbox"/> CD, Number of CD(s) _____	<input type="checkbox"/> After Allowance communication to Technology Center (TC) <input type="checkbox"/> Appeal Communication to Board of Appeals and Interferences <input type="checkbox"/> Appeal Communication to TC (Appeal Notice, Brief, Reply Brief) <input type="checkbox"/> Proprietary Information <input type="checkbox"/> Status Letter <input checked="" type="checkbox"/> Other Enclosure(s) (please identify below): Return Receipt Postcard, and Amendment Transmittal
SIGNATURE OF APPLICANT, ATTORNEY, OR AGENT		
Firm or Individual name	JENKENS & GILCHRIST, A PROFESSIONAL CORPORATION Daniel G. Nguyen - 42,933	
Signature		
Date	September 8, 2004	

I hereby certify that this correspondence is being deposited with the U.S. Postal Service with sufficient postage as First Class Mail, in an envelope addressed to: MS Amendment, Commissioner for Patents, P.O. Box 1450, Alexandria, VA 22313-1450, on the date shown below.	
Dated: September 8, 2004	Signature:  (Susan B. Jensen)

CHICAGO 294242v1 47079-00077

**AMENDMENTS TO THE CLAIMS**

Claims 1-21. (Previously Cancelled)

Claims 22-34. (Previously Withdrawn)

Claims 35-36. (Previously Cancelled)

37. (Currently Amended) A remote gaming method comprising:  
accessing, via a remote terminal, a gaming site on a global computer network connected to said remote terminal;  
providing, via said remote terminal, personal identification information to said gaming site;  
selecting, via said remote terminal, a game of chance ~~on a gaming machine~~ from a plurality of gaming machines located at a gaming establishment for remote play, said remote terminal being located outside said gaming establishment;  
placing, via said remote terminal, a wager for playing said selected game; and  
receiving randomly-generated text or graphical outcome data at said remote terminal for said selected game, said outcome data being generated by ~~the gaming machine~~ one of said plurality of gaming machines at said gaming establishment and relayed to said gaming site through a gaming server connected to said gaming site.

38. (Currently Amended) A remote gaming method using a gaming server, a remote terminal, and a gaming site on a global computer network, said gaming server being located at a gaming establishment, said remote terminal being located outside said gaming establishment, said gaming site being provided on said global computer network, the method comprising:  
receiving, at said gaming server, personal identification information, game selection information, and wager information from a player accessing said gaming site via said remote terminal, said remote terminal being connected to said global computer network;  
randomly generating outcome data at ~~a gaming machine~~ one of a plurality of gaming machines communicatively coupled to said gaming server, said outcome data being generated for a game selected according to said game selection information,



said ~~gaming machine~~ plurality of gaming machines being located at said gaming establishment;

receiving said outcome data at said gaming server; and

transmitting said outcome data from said gaming server to said gaming site for display to said player on said remote terminal in text or graphical form.

39. (Previously Presented) A method for playing a gaming machine located inside a gaming establishment from a remote terminal located outside the gaming establishment comprising:

establishing a communication link between said remote terminal and a gaming site on a global computer network, said gaming site in communication with a gaming server for collecting outcome data from gaming machines located inside the gaming establishment;

selecting a gaming machine at said gaming establishment using said remote terminal;

making a wager to play the selected gaming machine;

receiving outcome data, including game outcome, at said remote terminal resulting from a play of said gaming machine; and

generating a payout if said game outcome meets predetermined criteria.

40. (Previously Presented) The method of claim 39 wherein said outcome data comprises information identifying the value of said payout; and further comprising the step of using said payout information to simulate a display of said game outcome at said remote location.

41. (Previously Presented) The method of claim 39 further comprising using said outcome data to simulate a display of said game outcome on said remote terminal.

42. (Previously Presented) The method of claim 39, wherein said selected gaming machine comprises a slot machine and wherein said game outcome data includes a reel position.

43. (Previously Presented) The method of claim 39 wherein said selected gaming machine comprises a video poker machine including a display for displaying a poker hand.

44. (Previously Presented) The method of claim 39 wherein said step of receiving outcome data includes receiving outcome data from a plurality of gaming machines for remote play.

45. (Previously Presented) The method of claim 44 wherein said step of receiving outcome data includes receiving a gaming machine identifier.

46. (Previously Presented) The method of claim 44 wherein said step of receiving outcome data includes receiving a gaming machine type.

47. (Previously Presented) The method of claim 44 wherein said step of receiving outcome data includes receiving player preferences.

48. (Previously Presented) The method of claim 39 wherein said selected gaming machine comprises a slot machine and wherein said game outcome comprises information identifying a reel position of said gaming machine; and further comprising the step of using said outcome information to display said reel position on said remote terminal.

49. (Previously Presented) The method of claim 39 and further including the steps of receiving a player identifier; and transmitting said player identifier for identification of said player.

50. (Previously Presented) The method of claim 39 wherein said game outcome results from the server initiating game play on the selected gaming machine.

51. (Previously Presented) The method of claim 39 wherein said game outcome results from the manual game play on the selected gaming machine.

52. (Previously Presented) A remote computer for the remote play of a local gaming machine located within a gaming establishment and connected to a gaming server, the remote computer being located outside said gaming establishment, said remote computer connected to a gaming site through a global computing network served by said gaming server, said remote computer comprising:

a microprocessor;

memory connected to said microprocessor and including instructions for controlling said microprocessor; and

said microprocessor being operative with said instructions in said memory to:

receive information identifying a plurality of local gaming machines located within said gaming establishment from a gaming server;

transmit data selecting of at least one said plurality of local gaming machines for remote play;  
receive a text or graphical outcome resulting from a local play of each said selected local gaming machine; and  
generate a payout if said outcome meets predetermined criteria.

53. (Previously Presented) The remote computer of claim 52 wherein said selected gaming machine comprises a slot machine and wherein said outcome includes a reel position.

54. (Previously Presented) The remote computer of claim 52 wherein said operation of receiving information includes receiving information selecting at least two of said plurality of local gaming machines for remote play.

55. (Previously Presented) The remote computer of claim 52 wherein said operation of receiving information includes receiving a gaming machine identifier.

56. (Previously Presented) The remote computer of claim 52 wherein said operation of receiving information includes receiving a gaming machine type.

57. (Previously Presented) The remote computer of claim 52 wherein said operation of receiving information includes receiving player preferences.

58. (Previously Presented) The remote computer of claim 52 wherein said selected gaming machine comprises a video poker machine including a display for displaying a poker hand.

59. (Previously Presented) The remote computer of claim 52 wherein said outcome comprises data identifying the value of said payout; and further comprising the operation of using said payout data to simulate a display of said outcome at said remote location.

60. (Previously Presented) The remote computer of claim 52 wherein said outcome comprises information identifying a reel position of said selected gaming machine; and further comprising the operation of using said outcome data to display said reel position at said remote location.

61. (Previously Presented) The remote computer of claim 52 further including the operations of: receiving a player identifier; and transmitting said player identifier for identification of said player.

62. (Previously Amended) A remote computer located outside a gaming establishment, said gaming establishment having a plurality of gaming machines linked by a gaming server, said remote computer connected to a gaming site through a global computing network served by said gaming server comprising:

means for receiving information identifying a plurality of local gaming machines each engaged in play within said gaming establishment;

means for transmitting data from said remote computer for selecting at least one of said plurality of local gaming machines for information transfer;

means for receiving a text or graphical outcome resulting from a play of said selected local gaming machines; and

means for generating a payout if said outcome meets predetermined criteria.

**REMARKS**

Claims 37-62 were pending in this application. Claims 1-21, 35 and 36 were previously cancelled. Claims 22-34 were previously withdrawn. Claims 39-62 were previously added.

Claims 37 and 38 are currently amended in order to clarify that the game of chance is selected from a plurality of gaming machines residing at the gaming establishment. Support for the amendment may be found throughout the specification in general and at least on page 8, line 23 to page 9, line 2. No new matter was added.

**Claim Rejections Under 35 U.S.C. § 103(a)**

Claims 37-62 were rejected under 35 U.S.C. § 103(a) as being unpatentable over U.S. Patent No. 6,001,016 to Walker (“Walker”) in view of U.S. Patent Nos. 6,409,602 to Wiltshire (“Wiltshire”) and 6,183,366 to Goldberg (“Goldberg”). Claims 37 and 38 were further rejected under 35 U.S.C. § 103(a) as being unpatentable over U.S. Patent No. 6,012,984 to Roseman (“Roseman”) in view of Goldberg. In each case, the Examiner states that a primary reference (Walker and Roseman) fails to disclose a communication link between the remote terminal and a gaming site, but that a secondary reference (Goldberg) teaches the communication link, and it would have been obvious to modify the primary references to include this aspect of the invention. The Applicant respectfully traverses these rejections on the basis that, even if there is motivation to combine (which there is not), significant claim features and limitations are still missing from the proposed combinations.

The Applicant’s invention, as recited in independent claims 37-39, 52, and 62, is directed to a remote gaming method, and a computer therefor, where players at gaming terminals located outside a gaming establishment may play gaming machines located inside the gaming establishment. The invention allows players to play a real gaming machine (i.e., not a virtual gaming machine) without having to be present at the gaming establishment. Prior to the Applicant’s invention, players had to actually travel to the gaming establishment in order to play a real gaming machine. As one might imagine, there are tremendous advantages to being able to play a real gaming machine from one’s home, including savings in time, costs, and the overall convenience and comfort factor.

The Examiner contends that the Applicant's claimed invention is obvious. This, despite the fact that in the more than 10 years the Internet has been widely available, no one came up with the Applicant's invention. The closest thing that the Examiner has found so far is the remote gaming system of Walker. However, Walker also failed to come up with the claimed invention, even though the technological capability surely existed at the time Walker was filed. As explained in the previous response, Walker's "hopper" and "map" would seem to require that players actually be at the gaming establishment. Nowhere does Walker teach or suggest otherwise. Therefore, contrary to the Examiner's contention, Applicant respectfully submits that the claimed invention is anything but obvious.

In any case, combining Walker, Goldberg, and Wiltshire does not produce the claimed invention (the Roseman-Goldberg combination is addressed later herein). All of the independent claims (claims 37-39, 52, and 62) recite **two** intermediate nodes – a gaming server and a gaming site – between the gaming machine and the remote gaming terminal. The gaming machine generates outcome data (e.g., reel position, win/lose indicator, amount won or lost, etc.) and passes the data through the **two** intermediate nodes to the gaming terminal. The relevant portions of the claims are reproduced below for the Examiner's convenience. Note that claim 62 is written in means-plus-function form and must be construed under 35 U.S.C. § 112, ¶ 6, to cover the corresponding structures disclosed in the specification, including the gaming server and the gaming site.

Claim 37: "...receiving randomly-generated text or graphical outcome data at said remote terminal for said selected game, said outcome data being generated by the gaming machine at said gaming establishment and relayed to said **gaming site** through a **gaming server** connected to said gaming site."

Claim 38: "...transmitting said outcome data from said **gaming server** to said **gaming site** for display to said player on said remote terminal in text or graphical form."

Claim 39: "...said **gaming site** in communication with a **gaming server** for collecting outcome data from gaming machines located inside the gaming establishment..."

Claim 52 (preamble): "...said remote computer connected to a **gaming site** through a global computing network served by said **gaming server**..."

Claim 62: "...means for receiving a text or graphical outcome resulting from a play of said selected local gaming machines..."

Neither Walker, Goldberg, nor Wiltshire teaches the concept of using two intermediate nodes. On the contrary, Walker uses only one intermediate node, namely, a slot network server. (See, e.g., Walker, FIG. 1). Likewise, Goldberg also uses only one intermediate node, namely, a gaming site. As for Wiltshire, this reference does not appear to contain any intermediate nodes. (See, e.g., Wiltshire, FIG. 1D). Therefore, modifying Walker (a single-node system) with the teachings of Goldberg (another single-node system) and Wiltshire (a zero-node system) would produce a system that still has at most only one intermediate node.

The Examiner proposes to simply throw a couple of single-node systems together and thereby produce the two-node system of the claimed invention. However, when patentability turns on the question of obviousness, the mere fact that a device in a cited reference could have been modified to yield a device within the claimed invention does not make the modification obvious **unless the prior art suggested the desirability of the modification.** *In re Gordon*, 221 USPQ 1125, 1127 (Fed. Cir. 1984). The Examiner can satisfy the burden of showing the obviousness of the modification "only by showing some objective teaching in the prior art or that knowledge generally available to one of ordinary skill in the art would lead that individual to combine the relevant teachings of the references." *In re Fritch*, 23 USPQ2d 1780, 1783 (Fed. Cir. 1992).

In the present case, there is no motivation to add the Goldberg gaming site to the Walker system, at least not as a separate node. None of the references provide any reason or suggestion for keeping the gaming site separate from the slot network server. Moreover, the trend in high-technology has been steadily moving toward integration, not segregation. This is clearly seen from Goldberg itself in that the gaming site has a game controller incorporated therein, not as a separate node. (See Goldberg, FIG. 3). The numerous benefits of such integration are well-documented, including higher cost savings, better resource management, and a simpler, more streamlined approach overall. Therefore, if a person of ordinary skill in the art were to add the Goldberg gaming site to the Walker system, he or she would do so by combining the two nodes into one. Given the wholesale changes that would have to be made regardless, there is little or no benefit to be gained by keeping them separate.

As for Roseman, this reference (like Wiltshire) also uses zero intermediate nodes. Therefore, the combination of Roseman and Goldberg would again not produce the two-node system of the claimed invention. And in any case, the only potential benefit to adding the Goldberg gaming site is to make Roseman's gaming machine/server accessible via html pages. However, Roseman's gaming machine/server is already accessible via html pages (see, e.g., col. 5, lines 12-45) and would derive little or no benefit from the addition of the Goldberg gaming site. Indeed, the Examiner's proposed combination might negate the advantages of having a single, integrated gaming machine/server generate the html pages in the first place, including reducing the total number of machines/servers needed. Therefore, the Applicant respectfully submits no person of ordinary skill in the art would follow the course outlined by the Examiner.

Nevertheless, in order to expedite allowance of this application, claims 37 and 38 have been amended to clarify that the game of chance is selected from a plurality of gaming machines residing at the gaming establishment. Both Roseman and Goldberg teach a single gaming machine, i.e., a game server in Roseman and a game controller in Goldberg. Therefore, even if there is motivation to combine, the combination of Roseman and Goldberg would not produce the invention as now claimed in amended claims 37 and 38.

Accordingly, for at least the reasons stated above, withdrawal of the rejections against independent claims 37-39, 52, and 62 under 35 U.S.C. § 103(a) is respectfully requested.

As for claims 40-51 and 53-61, although they may recite independently allowable subject matter, these claims depend from independent claims 37-39, 52, and 62, and are therefore allowable for at least the reasons stated above.



Application No.: 09/688501

Docket No.: 47079-00077USPT

**CONCLUSION**

In view of the above, each of the presently pending claims in this application is believed to be in immediate condition for allowance. Accordingly, the Examiner is respectfully requested to pass this application to issue.

Dated: September 8, 2004

Respectfully submitted,

By   
Daniel G. Nguyen

Registration No.: 42,933

JENKENS & GILCHRIST, A PROFESSIONAL  
CORPORATION

225 W. Washington, Ste. 2600

Chicago, Illinois 60606-3418

(713) 951-3354

(713) 951-3314 Facsimile

Attorneys For Applicant

**PATENT APPLICATION FEE DETERMINATION RECORD**  
Effective October 1, 2001

Application or Docket Number

09/688,581

**CLAIMS AS FILED - PART I**

	(Column 1)	(Column 2)
TOTAL CLAIMS		
FOR	NUMBER FILED	NUMBER EXTRA
TOTAL CHARGEABLE CLAIMS	39 minus 20 = *	
INDEPENDENT CLAIMS	8 minus 3 = *	
MULTIPLE DEPENDENT CLAIM PRESENT	<input type="checkbox"/>	

\* If the difference in column 1 is less than zero, enter "0" in column 2

SMALL ENTITY TYPE

OR OTHER THAN SMALL ENTITY

RATE	FEE	OR	RATE	FEE
BASIC FEE	370.00		BASIC FEE	740.00
X\$ 9=		OR	X\$18=	
X42=		OR	X84=	
+140=		OR	+280=	
TOTAL	pd	OR	TOTAL	pd

**CLAIMS AS AMENDED - PART II**

9/10/04

	(Column 1)	(Column 2)	(Column 3)
AMENDMENT A	CLAIMS REMAINING AFTER AMENDMENT	HIGHEST NUMBER PREVIOUSLY PAID FOR	PRESENT EXTRA
Total	* 39	Minus ** 39	= -
Independent	* 8	Minus *** 8	= -
FIRST PRESENTATION OF MULTIPLE DEPENDENT CLAIM	<input type="checkbox"/>		

SMALL ENTITY OR OTHER THAN SMALL ENTITY

RATE	ADDITIONAL FEE	OR	RATE	ADDITIONAL FEE
X\$ 9=		OR	X\$18=	
X42=		OR	X84=	
+140=		OR	+280=	
TOTAL ADDIT. FEE		OR	TOTAL ADDIT. FEE	

	(Column 1)	(Column 2)	(Column 3)
AMENDMENT B	CLAIMS REMAINING AFTER AMENDMENT	HIGHEST NUMBER PREVIOUSLY PAID FOR	PRESENT EXTRA
Total	*	Minus **	=
Independent	*	Minus ***	=
FIRST PRESENTATION OF MULTIPLE DEPENDENT CLAIM	<input type="checkbox"/>		

RATE	ADDITIONAL FEE	OR	RATE	ADDITIONAL FEE
X\$ 9=		OR	X\$18=	
X42=		OR	X84=	
+140=		OR	+280=	
TOTAL ADDIT. FEE		OR	TOTAL ADDIT. FEE	

	(Column 1)	(Column 2)	(Column 3)
AMENDMENT C	CLAIMS REMAINING AFTER AMENDMENT	HIGHEST NUMBER PREVIOUSLY PAID FOR	PRESENT EXTRA
Total	*	Minus **	=
Independent	*	Minus ***	=
FIRST PRESENTATION OF MULTIPLE DEPENDENT CLAIM	<input type="checkbox"/>		

RATE	ADDITIONAL FEE	OR	RATE	ADDITIONAL FEE
X\$ 9=		OR	X\$18=	
X42=		OR	X84=	
+140=		OR	+280=	
TOTAL ADDIT. FEE		OR	TOTAL ADDIT. FEE	

\* If the entry in column 1 is less than the entry in column 2, write "0" in column 3.  
 \*\* If the "Highest Number Previously Paid For" IN THIS SPACE is less than 20, enter "20."  
 \*\*\* If the "Highest Number Previously Paid For" IN THIS SPACE is less than 3, enter "3."  
 The "Highest Number Previously Paid For" (Total or Independent) is the highest number found in the appropriate box in column 1.

BEST AVAILABLE COPY

**PATENT APPLICATION FEE DETERMINATION RECORD**  
Effective October 1, 2001

Application or Docket Number

09/688,501

**CLAIMS AS FILED - PART I**

	(Column 1)	(Column 2)
TOTAL CLAIMS		
FOR	NUMBER FILED	NUMBER EXTRA
TOTAL CHARGEABLE CLAIMS	39 minus 20 =	
INDEPENDENT CLAIMS	8 minus 3 =	
MULTIPLE DEPENDENT CLAIM PRESENT <input type="checkbox"/>		

\* If the difference in column 1 is less than zero, enter "0" in column 2

**CLAIMS AS AMENDED - PART II**

9/10/04

	(Column 1)	(Column 2)	(Column 3)
AMENDMENT A	CLAIMS REMAINING AFTER AMENDMENT	HIGHEST NUMBER PREVIOUSLY PAID FOR	PRESENT EXTRA
Total	39	Minus 39	= -
Independent	8	Minus 8	= -
FIRST PRESENTATION OF MULTIPLE DEPENDENT CLAIM <input type="checkbox"/>			

	(Column 1)	(Column 2)	(Column 3)
AMENDMENT B	CLAIMS REMAINING AFTER AMENDMENT	HIGHEST NUMBER PREVIOUSLY PAID FOR	PRESENT EXTRA
Total	39	Minus 39	= -
Independent	8	Minus 8	= -
FIRST PRESENTATION OF MULTIPLE DEPENDENT CLAIM <input type="checkbox"/>			

	(Column 1)	(Column 2)	(Column 3)
AMENDMENT C	CLAIMS REMAINING AFTER AMENDMENT	HIGHEST NUMBER PREVIOUSLY PAID FOR	PRESENT EXTRA
Total		Minus	=
Independent		Minus	=
FIRST PRESENTATION OF MULTIPLE DEPENDENT CLAIM <input type="checkbox"/>			

\* If the entry in column 1 is less than the entry in column 2, write "0" in column 3.  
 \*\* If the "Highest Number Previously Paid For" IN THIS SPACE is less than 20, enter "20."  
 \*\*\* If the "Highest Number Previously Paid For" IN THIS SPACE is less than 3, enter "3."  
 The "Highest Number Previously Paid For" (Total or Independent) is the highest number found in the appropriate box in column 1.

SMALL ENTITY TYPE  OR OTHER THAN SMALL ENTITY

RATE	FEE	OR	RATE	FEE
BASIC FEE	370.00	OR	BASIC FEE	740.00
X\$ 9=		OR	X\$18=	
X42=		OR	X84=	
+140=		OR	+280=	
TOTAL	pd	OR	TOTAL	pd

SMALL ENTITY OR OTHER THAN SMALL ENTITY

RATE	ADDITIONAL FEE	OR	RATE	ADDITIONAL FEE
X\$ 9=		OR	X\$18=	
X42=		OR	X84=	
+140=		OR	+280=	
TOTAL ADDIT. FEE		OR	TOTAL ADDIT. FEE	

RATE	ADDITIONAL FEE	OR	RATE	ADDITIONAL FEE
X\$ 9=		OR	X\$18=	
X42=		OR	X84=	
+140=		OR	+280=	
TOTAL ADDIT. FEE		OR	TOTAL ADDIT. FEE	

RATE	ADDITIONAL FEE	OR	RATE	ADDITIONAL FEE
X\$ 9=		OR	X\$18=	
X42=		OR	X84=	
+140=		OR	+280=	
TOTAL ADDIT. FEE		OR	TOTAL ADDIT. FEE	

BEST AVAILABLE COPY



UNITED STATES PATENT AND TRADEMARK OFFICE

UNITED STATES DEPARTMENT OF COMMERCE  
United States Patent and Trademark Office  
Address: COMMISSIONER FOR PATENTS  
P.O. Box 1450  
Alexandria, Virginia 22313-1450  
www.uspto.gov

APPLICATION NO.	FILING DATE	FIRST NAMED INVENTOR	ATTORNEY DOCKET NO.	CONFIRMATION NO.
09/688,501	10/16/2000	Shridhar P. Joshi	47079-00077	3225
30223	7590	09/28/2004	EXAMINER	
JENKENS & GILCHRIST, P.C. 225 WEST WASHINGTON SUITE 2600 CHICAGO, IL 60606			RADA, ALEX P	
			ART UNIT	PAPER NUMBER
			3714	

DATE MAILED: 09/28/2004

Please find below and/or attached an Office communication concerning this application or proceeding.



09/688,501

COMMISSIONER FOR PATENTS  
UNITED STATES PATENT AND TRADEMARK OFFICE  
P.O. Box 1450  
ALEXANDRIA, VA 22313-1450  
www.uspto.gov

Notice of Non-Compliant Amendment (37 CFR 1.121)

The amendment document filed on 9/10/04 is considered non-compliant because it has failed to meet the requirements of 37 CFR 1.121. In order for the amendment document to be compliant, correction of the following item(s) is required. Only the corrected section of the non-compliant amendment document must be resubmitted (in its entirety), e.g., the entire "Amendments to the claims" section of applicant's amendment document must be re-submitted. 37 CFR 1.121(h).

THE FOLLOWING CHECKED (X) ITEM(S) CAUSE THE AMENDMENT DOCUMENT TO BE NON-COMPLIANT:

- 1. Amendments to the specification:
  - A. Amended paragraph(s) do not include markings.
  - B. New paragraph(s) should not be underlined.
  - C. Other \_\_\_\_\_
- 2. Abstract:
  - A. Not presented on a separate sheet. 37 CFR 1.72.
  - B. Other \_\_\_\_\_
- 3. Amendments to the drawings: \_\_\_\_\_
- 4. Amendments to the claims:
  - A. A complete listing of all of the claims is not present.
  - B. The listing of claims does not include the text of all pending claims (including withdrawn claims)
  - C. Each claim has not been provided with the proper status identifier, and as such, the individual status of each claim cannot be identified. Note: the status of every claim must be indicated after its claim number by using one of the following 7 status identifiers: (Original), (Currently amended), (Canceled), (Withdrawn), (Previously presented), (New) and (Not entered).
  - D. The claims of this amendment paper have not been presented in ascending numerical order.
  - E. Other: \_\_\_\_\_

For further explanation of the amendment format required by 37 CFR 1.121, see MPEP Sec. 714 and the USPTO website at <http://www.uspto.gov/web/offices/pac/dapp/opla/preognotice/officeflyer.pdf>.

If the non-compliant amendment is a **PRELIMINARY AMENDMENT**, applicant is given ONE MONTH from the mail date of this letter to supply the corrected section which complies with 37 CFR 1.121. Failure to comply with 37 CFR 1.121 will result in non-entry of the preliminary amendment and examination on the merits will commence without consideration of the proposed changes in the preliminary amendment(s). This notice is not an action under 35 U.S.C. 132, and this **ONE MONTH** time limit is not extendable.

If the non-compliant amendment is a reply to a **NON-FINAL OFFICE ACTION** (including a submission for an RCE), and since the amendment appears to be a *bona fide* attempt to be a reply (37 CFR 1.135(c)), applicant is given a **TIME PERIOD** of ONE MONTH from the mailing of this notice within which to re-submit the corrected section which complies with 37 CFR 1.121 in order to avoid abandonment. **EXTENSIONS OF THIS TIME PERIOD ARE AVAILABLE UNDER 37 CFR 1.136(a).**

If the amendment is a reply to a **FINAL REJECTION**, this form may be an attachment to an Advisory Action. The period for response to a final rejection continues to run from the date set in the final rejection, and is not affected by the non-compliant status of the amendment.

Ron Lloyd  
Legal Instruments Examiner (LIE)

703-305-3575  
Telephone No.



3225

IPW

PTO/SB/21 (04-04)  
 Approved for use through 07/31/2006. OMB 0651-0031  
 U.S. Patent and Trademark Office; U.S. DEPARTMENT OF COMMERCE

Under the Paperwork Reduction Act of 1995, no persons are required to respond to a collection of information unless it displays a valid OMB control number.

<b>TRANSMITTAL FORM</b> <small>(to be used for all correspondence after initial filing)</small>	Application Number	09/688501	
	Filing Date	October 16, 2000	
	First Named Inventor	Shridhar P. Joshi	
	Art Unit	3225	
	Examiner Name	Alex P. Rada	
Total Number of Pages in This Submission	15	Attorney Docket Number	47079-00077USPT

ENCLOSURES (Check all that apply)		
<input type="checkbox"/> Fee Transmittal Form <input type="checkbox"/> Fee Attached <input type="checkbox"/> Amendment/Reply <input type="checkbox"/> After Final <input type="checkbox"/> Affidavits/declaration(s) <input type="checkbox"/> Extension of Time Request <input type="checkbox"/> Express Abandonment Request <input type="checkbox"/> Information Disclosure Statement <input type="checkbox"/> Certified Copy of Priority Document(s) <input type="checkbox"/> Response to Missing Parts/ Incomplete Application <input type="checkbox"/> Response to Missing Parts under 37 CFR 1.52 or 1.53	<input type="checkbox"/> Drawing(s) <input type="checkbox"/> Licensing-related Papers <input type="checkbox"/> Petition <input type="checkbox"/> Petition to Convert to a Provisional Application <input type="checkbox"/> Power of Attorney, Revocation Change of Correspondence Address <input type="checkbox"/> Terminal Disclaimer <input type="checkbox"/> Request for Refund <input type="checkbox"/> CD, Number of CD(s) _____	<input type="checkbox"/> After Allowance communication to Technology Center (TC) <input type="checkbox"/> Appeal Communication to Board of Appeals and Interferences <input type="checkbox"/> Appeal Communication to TC (Appeal Notice, Brief, Reply Brief) <input type="checkbox"/> Proprietary Information <input type="checkbox"/> Status Letter <input checked="" type="checkbox"/> Other Enclosure(s) (please identify below): Return Receipt Postcard, Amendment Transmittal, and Response to Notice of Non-Compliance
Remarks		

SIGNATURE OF APPLICANT, ATTORNEY, OR AGENT	
Firm or Individual name	JENKENS & GILCHRIST, A PROFESSIONAL CORPORATION Daniel G. Nguyen - 42,933
Signature	<i>Daniel Nguyen</i>
Date	10/8/04

I hereby certify that this correspondence is being deposited with the U.S. Postal Service with sufficient postage as First Class Mail, in an envelope addressed to: MS Amendment, Commissioner for Patents, P.O. Box 1450, Alexandria, VA 22313-1450, on the date shown below.	
Dated: 10/8/04	Signature: <i>Susan B. Jensen</i> (Susan B. Jensen)

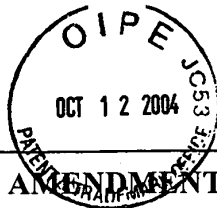

**AMENDMENT TRANSMITTAL LETTER**

Docket No.  
47079-00077USPT

Application No. 09/688501	Filing Date October 16, 2000	Examiner Alex P. Rada	Art Unit 3225
------------------------------	---------------------------------	--------------------------	------------------

Applicant(s): Shridhar P. Joshi

Invention: METHOD OF TRANSFERRING GAMING DATA ON A GLOBAL COMPUTER NETWORK

**TO THE COMMISSIONER FOR PATENTS**

Transmitted herewith is an amendment in the above-identified application.

The fee has been calculated and is transmitted as shown below.

CLAIMS AS AMENDED					
	Claims Remaining After Amendment	Highest Number Previously Paid	Number Extra Claims Present	Rate	
Total Claims	39	- 62 =	0	x	0.00
Independent Claims	8	- 8 =	0	x	0.00
Multiple Dependent Claims (check if applicable) <input type="checkbox"/>					
Other fee (please specify):					
<b>TOTAL ADDITIONAL FEE FOR THIS AMENDMENT:</b>					<b>0.00</b>

- Large Entity  Small Entity
- No additional fee is required for this amendment.
- Please charge Deposit Account No. \_\_\_\_\_ in the amount of \$ \_\_\_\_\_ .  
A duplicate copy of this sheet is enclosed.
- A check in the amount of \$ \_\_\_\_\_ to cover the filing fee is enclosed.
- Payment by credit card. Form PTO-2038 is attached.
- The Director is hereby authorized to charge and credit Deposit Account No. 10-0447  
as described below. A duplicate copy of this sheet is enclosed.
- Credit any overpayment.
- Charge any additional filing or application processing fees required under 37 CFR 1.16 and 1.17.

Daniel G. Nguyen  
Daniel G. Nguyen  
Attorney Reg. No.: 42,933

Dated: 10/8/04

JENKENS & GILCHRIST, A PROFESSIONAL CORPORATION  
225 W. Washington, Ste. 2600  
Chicago, Illinois 60606-3418  
(312) 425-8513

I hereby certify that this correspondence is being deposited with the U.S. Postal Service with sufficient postage as First Class Mail, in an envelope addressed to: MS Amendment, Commissioner for Patents, P.O. Box 1450, Alexandria, VA 22313-1450, on the date shown below.

Dated: 10/8/04 Signature: Susan B. Jensen (Susan B. Jensen)



I hereby certify that this correspondence is being deposited with the U.S. Postal Service with sufficient postage as First Class Mail, in an envelope addressed to: MS Amendment, Commissioner for Patents, P.O. Box 1450, Alexandria, VA 22313-1450, on the date shown below.

Dated: 10/8/04

Signature: Susan B. Jensen  
(Susan B. Jensen)

Docket No.: 47079-00077USPT  
(PATENT)

**IN THE UNITED STATES PATENT AND TRADEMARK OFFICE**

In re Patent Application of:  
Shridhar P. Joshi

Application No.: 09/688501

Art Unit: 3225

Filed: October 16, 2000

Examiner: Alex P. Rada

For: METHOD OF TRANSFERRING GAMING  
DATA ON A GLOBAL COMPUTER  
NETWORK

**RESPONSE TO NOTICE OF NON-COMPLIANCE**

MS Amendment  
Commissioner for Patents  
P.O. Box 1450  
Alexandria, VA 22313-1450

Dear Sir:

**INTRODUCTORY COMMENTS**

In response to the Notice of Non-Compliant Response dated September 28, 2004, Applicant resubmits herewith the reply previously filed in connection with the Office Action dated June 16, 2004.

**Amendments to the Claims** are reflected in the listing of claims which begins on page 2 of this paper.

**Remarks/Arguments** begin on page 9 of this paper.



**AMENDMENTS TO THE CLAIMS**

Claims 1-21. (Previously Cancelled)

22. (Previously Withdrawn) A method for transferring gaming data on a global computer network comprising:

- receiving player identification information from outside of a gaming establishment;
- analyzing said player identification information;
- requesting player input regarding a random event;
- receiving and analyzing said input;
- generating a random number within said gaming establishment;
- interpreting said random number to determine a text or graphical outcome; and
- transmitting said outcome to a player through said global computer network.

23. (Previously Withdrawn) The method of Claim 22, wherein said random event takes place in a microprocessor within a gaming machine located within said gaming establishment.

24. (Previously Withdrawn) The method of Claim 22, wherein said random event takes place in a microprocessor within a gaming establishment server.

25. (Previously Withdrawn) The method of Claim 22, wherein said global computer network is the Internet.

26. (Previously Withdrawn) A method of receiving transferred data via a global computer network, comprising:

- accessing a global computer network from outside a gaming establishment;
- inputting identification information into said global computer network;
- gaining access to a server within said gaming establishment;
- requesting the generation of a random number, said random number being generated from within said gaming establishment; and
- receiving a text or graphical outcome of said random number generation via said global computer network.

27. (Previously Withdrawn) The method of Claim 26, wherein said global computer network is the Internet.

28. (Previously Withdrawn) The method of Claim 26, wherein said generation of said random number is accomplished at a gaming machine within said gaming establishment.

29. (Previously Withdrawn) The method of Claim 26, wherein said generation of said random number is accomplished at a gaming establishment server.

30. (Previously Withdrawn) The method of Claim 26, wherein the step of receiving is accomplished via said global computer network.

31. (Previously Withdrawn) The method of Claim 26, wherein the step of receiving is accomplished through the Internet.

32. (Previously Withdrawn) An interactive site on a global computer network comprising:  
a page including one or more game choices to allow a player to participate in a remote random event;  
data means to input data;  
outcome means to receive text or graphical outcomes of a remote random event; and  
notification means to notify said player of said outcomes.

33. (Previously Withdrawn) The interactive web site of Claim 32, wherein said page is an Internet-based World Wide Web page.

34. (Previously Withdrawn) The interactive web site of Claim 32, wherein said remote random event occurs in a slot machine.

Claims 35-36. (Previously Cancelled)

37. (Currently Amended) A remote gaming method comprising:
- accessing, via a remote terminal, a gaming site on a global computer network connected to said remote terminal;
  - providing, via said remote terminal, personal identification information to said gaming site;
  - selecting, via said remote terminal, a game of chance ~~on a gaming machine~~ from a plurality of gaming machines located at a gaming establishment for remote play, said remote terminal being located outside said gaming establishment;
  - placing, via said remote terminal, a wager for playing said selected game; and
  - receiving randomly-generated text or graphical outcome data at said remote terminal for said selected game, said outcome data being generated by ~~the gaming machine~~ one of said plurality of gaming machines at said gaming establishment and relayed to said gaming site through a gaming server connected to said gaming site.
38. (Currently Amended) A remote gaming method using a gaming server, a remote terminal, and a gaming site on a global computer network, said gaming server being located at a gaming establishment, said remote terminal being located outside said gaming establishment, said gaming site being provided on said global computer network, the method comprising:
- receiving, at said gaming server, personal identification information, game selection information, and wager information from a player accessing said gaming site via said remote terminal, said remote terminal being connected to said global computer network;
  - randomly generating outcome data at ~~a gaming machine~~ one of a plurality of gaming machines communicatively coupled to said gaming server, said outcome data being generated for a game selected according to said game selection information, said ~~gaming machine~~ plurality of gaming machines being located at said gaming establishment;
  - receiving said outcome data at said gaming server; and
  - transmitting said outcome data from said gaming server to said gaming site for display to said player on said remote terminal in text or graphical form.

39. (Previously Presented) A method for playing a gaming machine located inside a gaming establishment from a remote terminal located outside the gaming establishment comprising:

establishing a communication link between said remote terminal and a gaming site on a global computer network, said gaming site in communication with a gaming server for collecting outcome data from gaming machines located inside the gaming establishment;

selecting a gaming machine at said gaming establishment using said remote terminal;

making a wager to play the selected gaming machine;

receiving outcome data, including game outcome, at said remote terminal resulting from a play of said gaming machine; and

generating a payout if said game outcome meets predetermined criteria.

40. (Previously Presented) The method of claim 39 wherein said outcome data comprises information identifying the value of said payout; and further comprising the step of using said payout information to simulate a display of said game outcome at said remote location.

41. (Previously Presented) The method of claim 39 further comprising using said outcome data to simulate a display of said game outcome on said remote terminal.

42. (Previously Presented) The method of claim 39, wherein said selected gaming machine comprises a slot machine and wherein said game outcome data includes a reel position.

43. (Previously Presented) The method of claim 39 wherein said selected gaming machine comprises a video poker machine including a display for displaying a poker hand.

44. (Previously Presented) The method of claim 39 wherein said step of receiving outcome data includes receiving outcome data from a plurality of gaming machines for remote play.

45. (Previously Presented) The method of claim 44 wherein said step of receiving outcome data includes receiving a gaming machine identifier.

46. (Previously Presented) The method of claim 44 wherein said step of receiving outcome data includes receiving a gaming machine type.

47. (Previously Presented) The method of claim 44 wherein said step of receiving outcome data includes receiving player preferences.

48. (Previously Presented) The method of claim 39 wherein said selected gaming machine comprises a slot machine and wherein said game outcome comprises information identifying a reel position of said gaming machine; and further comprising the step of using said outcome information to display said reel position on said remote terminal.

49. (Previously Presented) The method of claim 39 and further including the steps of receiving a player identifier; and transmitting said player identifier for identification of said player.

50. (Previously Presented) The method of claim 39 wherein said game outcome results from the server initiating game play on the selected gaming machine.

51. (Previously Presented) The method of claim 39 wherein said game outcome results from the manual game play on the selected gaming machine.

52. (Previously Presented) A remote computer for the remote play of a local gaming machine located within a gaming establishment and connected to a gaming server, the remote computer being located outside said gaming establishment, said remote computer connected to a gaming site through a global computing network served by said gaming server, said remote computer comprising:

a microprocessor;

memory connected to said microprocessor and including instructions for controlling said microprocessor; and

said microprocessor being operative with said instructions in said memory to:

receive information identifying a plurality of local gaming machines located within said gaming establishment from a gaming server;

transmit data selecting of at least one said plurality of local gaming machines for remote play;

receive a text or graphical outcome resulting from a local play of each said selected local gaming machine; and

generate a payout if said outcome meets predetermined criteria.

53. (Previously Presented) The remote computer of claim 52 wherein said selected gaming machine comprises a slot machine and wherein said outcome includes a reel position.

54. (Previously Presented) The remote computer of claim 52 wherein said operation of receiving information includes receiving information selecting at least two of said plurality of local gaming machines for remote play.

55. (Previously Presented) The remote computer of claim 52 wherein said operation of receiving information includes receiving a gaming machine identifier.

56. (Previously Presented) The remote computer of claim 52 wherein said operation of receiving information includes receiving a gaming machine type.

57. (Previously Presented) The remote computer of claim 52 wherein said operation of receiving information includes receiving player preferences.

58. (Previously Presented) The remote computer of claim 52 wherein said selected gaming machine comprises a video poker machine including a display for displaying a poker hand.

59. (Previously Presented) The remote computer of claim 52 wherein said outcome comprises data identifying the value of said payout; and further comprising the operation of using said payout data to simulate a display of said outcome at said remote location.

60. (Previously Presented) The remote computer of claim 52 wherein said outcome comprises information identifying a reel position of said selected gaming machine; and further comprising the operation of using said outcome data to display said reel position at said remote location.

61. (Previously Presented) The remote computer of claim 52 further including the operations of: receiving a player identifier; and transmitting said player identifier for identification of said player.

.62. (Previously Presented) A remote computer located outside a gaming establishment, said gaming establishment having a plurality of gaming machines linked by a gaming server, said remote computer connected to a gaming site through a global computing network served by said gaming server comprising:

means for receiving information identifying a plurality of local gaming machines each engaged in play within said gaming establishment;

means for transmitting data from said remote computer for selecting at least one of said plurality of local gaming machines for information transfer;

means for receiving a text or graphical outcome resulting from a play of said selected local gaming machines; and

means for generating a payout if said outcome meets predetermined criteria.

**REMARKS**

Claims 37-62 were pending in this application. Claims 1-21, 35 and 36 were previously cancelled. Claims 22-34 were previously withdrawn. Claims 39-62 were previously added.

Claims 37 and 38 are currently amended in order to clarify that the game of chance is selected from a plurality of gaming machines residing at the gaming establishment. Support for the amendment may be found throughout the specification in general and at least on page 8, line 23 to page 9, line 2. No new matter was added.

**Claim Rejections Under 35 U.S.C. § 103(a)**

Claims 37-62 were rejected under 35 U.S.C. § 103(a) as being unpatentable over U.S. Patent No. 6,001,016 to Walker ("Walker") in view of U.S. Patent Nos. 6,409,602 to Wiltshire ("Wiltshire") and 6,183,366 to Goldberg ("Goldberg"). Claims 37 and 38 were further rejected under 35 U.S.C. § 103(a) as being unpatentable over U.S. Patent No. 6,012,984 to Roseman ("Roseman") in view of Goldberg. In each case, the Examiner states that a primary reference (Walker and Roseman) fails to disclose a communication link between the remote terminal and a gaming site, but that a secondary reference (Goldberg) teaches the communication link, and it would have been obvious to modify the primary references to include this aspect of the invention. The Applicant respectfully traverses these rejections on the basis that, even if there is motivation to combine (which there is not), significant claim features and limitations are still missing from the proposed combinations.

The Applicant's invention, as recited in independent claims 37-39, 52, and 62, is directed to a remote gaming method, and a computer therefor, where players at gaming terminals located outside a gaming establishment may play gaming machines located inside the gaming establishment. The invention allows players to play a real gaming machine (i.e., not a virtual gaming machine) without having to be present at the gaming establishment. Prior to the Applicant's invention, players had to actually travel to the gaming establishment in order to play a real gaming machine. As one might imagine, there are tremendous advantages to being able to play a real gaming machine from one's home, including savings in time, costs, and the overall convenience and comfort factor.



The Examiner contends that the Applicant's claimed invention is obvious. This, despite the fact that in the more than 10 years the Internet has been widely available, no one came up with the Applicant's invention. The closest thing that the Examiner has found so far is the remote gaming system of Walker. However, Walker also failed to come up with the claimed invention, even though the technological capability surely existed at the time Walker was filed. As explained in the previous response, Walker's "hopper" and "map" would seem to require that players actually be at the gaming establishment. Nowhere does Walker teach or suggest otherwise. Therefore, contrary to the Examiner's contention, Applicant respectfully submits that the claimed invention is anything but obvious.

In any case, combining Walker, Goldberg, and Wiltshire does not produce the claimed invention (the Roseman-Goldberg combination is addressed later herein). All of the independent claims (claims 37-39, 52, and 62) recite **two** intermediate nodes – a gaming server and a gaming site – between the gaming machine and the remote gaming terminal. The gaming machine generates outcome data (e.g., reel position, win/lose indicator, amount won or lost, etc.) and passes the data through the **two** intermediate nodes to the gaming terminal. The relevant portions of the claims are reproduced below for the Examiner's convenience. Note that claim 62 is written in means-plus-function form and must be construed under 35 U.S.C. § 112, ¶ 6, to cover the corresponding structures disclosed in the specification, including the gaming server and the gaming site.

Claim 37: "...receiving randomly-generated text or graphical outcome data at said remote terminal for said selected game, said outcome data being generated by the gaming machine at said gaming establishment and relayed to said **gaming site** through a **gaming server** connected to said gaming site."

Claim 38: "...transmitting said outcome data from said **gaming server** to said **gaming site** for display to said player on said remote terminal in text or graphical form."

Claim 39: "...said **gaming site** in communication with a **gaming server** for collecting outcome data from gaming machines located inside the gaming establishment..."

Claim 52 (preamble): "...said remote computer connected to a **gaming site** through a global computing network served by said **gaming server**..."

Claim 62: "...means for receiving a text or graphical outcome resulting from a play of said selected local gaming machines..."

Neither Walker, Goldberg, nor Wiltshire teaches the concept of using two intermediate nodes. On the contrary, Walker uses only one intermediate node, namely, a slot network server. (See, e.g., Walker, FIG. 1). Likewise, Goldberg also uses only one intermediate node, namely, a gaming site. As for Wiltshire, this reference does not appear to contain any intermediate nodes. (See, e.g., Wiltshire, FIG. 1D). Therefore, modifying Walker (a single-node system) with the teachings of Goldberg (another single-node system) and Wiltshire (a zero-node system) would produce a system that still has at most only one intermediate node.

The Examiner proposes to simply throw a couple of single-node systems together and thereby produce the two-node system of the claimed invention. However, when patentability turns on the question of obviousness, the mere fact that a device in a cited reference could have been modified to yield a device within the claimed invention does not make the modification obvious **unless the prior art suggested the desirability of the modification**. *In re Gordon*, 221 USPQ 1125, 1127 (Fed. Cir. 1984). The Examiner can satisfy the burden of showing the obviousness of the modification "only by showing some objective teaching in the prior art or that knowledge generally available to one of ordinary skill in the art would lead that individual to combine the relevant teachings of the references." *In re Fritch*, 23 USPQ2d 1780, 1783 (Fed. Cir. 1992).

In the present case, there is no motivation to add the Goldberg gaming site to the Walker system, at least not as a separate node. None of the references provide any reason or suggestion for keeping the gaming site separate from the slot network server. Moreover, the trend in high-technology has been steadily moving toward integration, not segregation. This is clearly seen from Goldberg itself in that the gaming site has a game controller incorporated therein, not as a separate node. (See Goldberg, FIG. 3). The numerous benefits of such integration are well-documented, including higher cost savings, better resource management, and a simpler, more streamlined approach overall. Therefore, if a person of ordinary skill in the art were to add the Goldberg gaming site to the Walker system, he or she would do so by combining the two nodes into one. Given the wholesale changes that would have to be made regardless, there is little or no benefit to be gained by keeping them separate.

As for Roseman, this reference (like Wiltshire) also uses zero intermediate nodes. Therefore, the combination of Roseman and Goldberg would again not produce the two-node system of the claimed invention. And in any case, the only potential benefit to adding the Goldberg gaming site is to make Roseman's gaming machine/server accessible via html pages. However, Roseman's gaming machine/server is already accessible via html pages (see, e.g., col. 5, lines 12-45) and would derive little or no benefit from the addition of the Goldberg gaming site. Indeed, the Examiner's proposed combination might negate the advantages of having a single, integrated gaming machine/server generate the html pages in the first place, including reducing the total number of machines/servers needed. Therefore, the Applicant respectfully submits no person of ordinary skill in the art would follow the course outlined by the Examiner.

Nevertheless, in order to expedite allowance of this application, claims 37 and 38 have been amended to clarify that the game of chance is selected from a plurality of gaming machines residing at the gaming establishment. Both Roseman and Goldberg teach a single gaming machine, i.e., a game server in Roseman and a game controller in Goldberg. Therefore, even if there is motivation to combine, the combination of Roseman and Goldberg would not produce the invention as now claimed in amended claims 37 and 38.

Accordingly, for at least the reasons stated above, withdrawal of the rejections against independent claims 37-39, 52, and 62 under 35 U.S.C. § 103(a) is respectfully requested.

As for claims 40-51 and 53-61, although they may recite independently allowable subject matter, these claims depend from independent claims 37-39, 52, and 62, and are therefore allowable for at least the reasons stated above.

**CONCLUSION**

In view of the above, the Applicant believes this reponse to be in compliance and each of the presently pending claims in this application is believed to be in immediate condition for allowance. Accordingly, the Examiner is respectfully requested to pass this application to issue.

Dated: 10/8/04

Respectfully submitted,

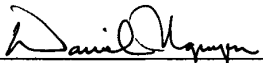
By 

Daniel G. Nguyen  
Registration No.: 42,933  
JENKENS & GILCHRIST, A PROFESSIONAL  
CORPORATION  
225 W. Washington, Ste. 2600  
Chicago, Illinois 60606-3418  
(713) 951-3354  
(713) 951-3314 Facsimile  
Attorneys For Applicant



UNITED STATES PATENT AND TRADEMARK OFFICE

UNITED STATES DEPARTMENT OF COMMERCE  
United States Patent and Trademark Office  
Address: COMMISSIONER FOR PATENTS  
P.O. Box 1450  
Alexandria, Virginia 22313-1450  
www.uspto.gov

*SN*

APPLICATION NO.	FILING DATE	FIRST NAMED INVENTOR	ATTORNEY DOCKET NO.	CONFIRMATION NO.
09/688,501	10/16/2000	Shridhar P. Joshi	47079-00077	3225

30223 7590 12/22/2004  
JENKENS & GILCHRIST, P.C.  
225 WEST WASHINGTON  
SUITE 2600  
CHICAGO, IL 60606

EXAMINER

RADA, ALEX P

ART UNIT PAPER NUMBER

3714

DATE MAILED: 12/22/2004

Please find below and/or attached an Office communication concerning this application or proceeding.

**DETAILED ACTION**

***Response to Amendment***

The reply filed on October 12, 2004 is not fully responsive to the prior Office Action because of the following omission(s) or matter(s): The status identifiers for some of the claims are incorrect. Claims 1-21 and 35-36 must have a status identifier of (cancelled) and claims 22-34 must have the status identifier of (Withdrawn). The examiner notes that the status of every claim must be indicated after its claim number by using one of the following 7 permissible status identifiers: (original), (Currently Amended), (Canceled), (Withdrawn), (Previously Presented), (New) and (Not Entered). See 37 CFR 1.111. Since the above-mentioned reply appears to be *bona fide*, applicant is given **ONE (1) MONTH or THIRTY (30) DAYS** from the mailing date of this notice, whichever is longer, within which to supply the omission or correction in order to avoid abandonment. EXTENSIONS OF THIS TIME PERIOD MAY BE GRANTED UNDER 37 CFR 1.136(a).

***Conclusion***

Any inquiry concerning this communication or earlier communications from the examiner should be directed to Alex P. Rada whose telephone number is 571-272-4452. The examiner can normally be reached on Monday - Friday, 08:00-16:00.

If attempts to reach the examiner by telephone are unsuccessful, the examiner's supervisor, Derris Banks can be reached on 571-272-4419.

AR  
APR



**DERRIS H. BANKS  
SUPERVISORY PATENT EXAMINER  
TECHNOLOGY CENTER 3700**

DFW



PTO/SB/21 (04-04)

Approved for use through 07/31/2006. OMB 0651-0031

U.S. Patent and Trademark Office; U.S. DEPARTMENT OF COMMERCE

Under the Paperwork Reduction Act of 1995, no persons are required to respond to a collection of information unless it displays a valid OMB control number.

<b>TRANSMITTAL FORM</b> <small>(to be used for all correspondence after initial filing)</small>	Application Number	09/688501	
	Filing Date	October 16, 2000	
	First Named Inventor	Shridhar P. Joshi	
	Art Unit	3225	
	Examiner Name	Alex P. Rada	
Total Number of Pages in This Submission	15	Attorney Docket Number	47079-00077USPT

ENCLOSURES (Check all that apply)		
<input type="checkbox"/> Fee Transmittal Form <input type="checkbox"/> Fee Attached <input type="checkbox"/> Amendment/Reply <input type="checkbox"/> After Final <input type="checkbox"/> Affidavits/declaration(s) <input type="checkbox"/> Extension of Time Request <input type="checkbox"/> Express Abandonment Request <input type="checkbox"/> Information Disclosure Statement <input type="checkbox"/> Certified Copy of Priority Document(s) <input type="checkbox"/> Response to Missing Parts/Incomplete Application <input type="checkbox"/> Response to Missing Parts under 37 CFR 1.52 or 1.53	<input type="checkbox"/> Drawing(s) <input type="checkbox"/> Licensing-related Papers <input type="checkbox"/> Petition <input type="checkbox"/> Petition to Convert to a Provisional Application <input type="checkbox"/> Power of Attorney, Revocation Change of Correspondence Address <input type="checkbox"/> Terminal Disclaimer <input type="checkbox"/> Request for Refund <input type="checkbox"/> CD, Number of CD(s) _____	<input type="checkbox"/> After Allowance communication to Technology Center (TC) <input type="checkbox"/> Appeal Communication to Board of Appeals and Interferences <input type="checkbox"/> Appeal Communication to TC (Appeal Notice, Brief, Reply Brief) <input type="checkbox"/> Proprietary Information <input type="checkbox"/> Status Letter <input checked="" type="checkbox"/> Other Enclosure(s) (please identify below): Return Receipt Postcard, Amendment Transmittal, and Response to Notice of Non-Compliance
		Remarks

SIGNATURE OF APPLICANT, ATTORNEY, OR AGENT	
Firm or Individual name	JENKENS & GILCHRIST, A PROFESSIONAL CORPORATION Daniel G. Nguyen - 42,933
Signature	<i>Daniel Nguyen</i>
Date	January 18, 2005

I hereby certify that this correspondence is being deposited with the U.S. Postal Service with sufficient postage as First Class Mail, in an envelope addressed to: MS Amendment, Commissioner for Patents, P.O. Box 1450, Alexandria, VA 22313-1450, on the date shown below.	
Dated: January 18, 2005	Signature: <i>Susan B. Jensen</i> (Susan B. Jensen)



**AMENDMENT TRANSMITTAL LETTER**

Docket No.  
47079-00077USPT

Application No. 09/688501	Filing Date October 16, 2000	Examiner Alex P. Rada	Art Unit 3225
------------------------------	---------------------------------	--------------------------	------------------

Applicant(s): Shridhar P. Joshi

Invention: METHOD OF TRANSFERRING GAMING DATA ON A GLOBAL COMPUTER NETWORK

**TO THE COMMISSIONER FOR PATENTS**

Transmitted herewith is an amendment in the above-identified application.

The fee has been calculated and is transmitted as shown below.

CLAIMS AS AMENDED					
	Claims Remaining After Amendment	Highest Number Previously Paid	Number Extra Claims Present	Rate	
Total Claims	39	- 62 =	0	x	0.00
Independent Claims	8	- 8 =	0	x	0.00
Multiple Dependent Claims (check if applicable) <input type="checkbox"/>					
Other fee (please specify):					
<b>TOTAL ADDITIONAL FEE FOR THIS AMENDMENT:</b>					<b>0.00</b>

- Large Entity  Small Entity
- No additional fee is required for this amendment.
- Please charge Deposit Account No. \_\_\_\_\_ in the amount of \$ \_\_\_\_\_  
A duplicate copy of this sheet is enclosed.
- A check in the amount of \$ \_\_\_\_\_ to cover the filing fee is enclosed.
- Payment by credit card. Form PTO-2038 is attached.
- The Director is hereby authorized to charge and credit Deposit Account No. 10-0447  
as described below. A duplicate copy of this sheet is enclosed.
- Credit any overpayment.
- Charge any additional filing or application processing fees required under 37 CFR 1.16 and 1.17.

Daniel Nguyen  
Daniel G. Nguyen  
Attorney Reg. No.: 42,933

Dated: January 18, 2005

JENKENS & GILCHRIST, A PROFESSIONAL CORPORATION  
225 W. Washington, Ste. 2600  
Chicago, Illinois 60606-3418  
(312) 425-8513

I hereby certify that this correspondence is being deposited with the U.S. Postal Service with sufficient postage as First Class Mail, in an envelope addressed to: MS Amendment, Commissioner for Patents, P.O. Box 1450, Alexandria, VA 22313-1450, on the date shown below.

Dated: January 18, 2005

Signature: Susan B. Jensen (Susan B. Jensen)



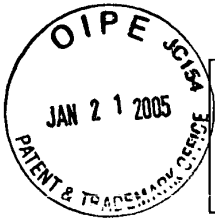

I hereby certify that this correspondence is being deposited with the U.S. Postal Service with sufficient postage as First Class Mail, in an envelope addressed to: MS Amendment, Commissioner for Patents, P.O. Box 1450, Alexandria, VA 22313-1450, on the date shown below.

Dated: January 18, 2005

Signature:

*Susan B. Jensen*  
(Susan B. Jensen)

Docket No.: 47079-00077USPT  
(PATENT)

**IN THE UNITED STATES PATENT AND TRADEMARK OFFICE**

In re Patent Application of:  
Shridhar P. Joshi

Application No.: 09/688501

Art Unit: 3225

Filed: October 16, 2000

Examiner: Alex P. Rada

For: METHOD OF TRANSFERRING GAMING  
DATA ON A GLOBAL COMPUTER  
NETWORK

**RESPONSE TO NOTICE OF NON-COMPLIANCE**

MS Amendment  
Commissioner for Patents  
P.O. Box 1450  
Alexandria, VA 22313-1450

Dear Sir:

**INTRODUCTORY COMMENTS**

Responsive to the Communication (Detailed Action/Response to Amendment) mailed December 22, 2004, reconsideration and allowance of the present application is respectfully requested in view of the following amendments and remarks.

**Amendments to the Claims** are reflected in the listing of claims which begins on page 2 of this paper.

**Remarks/Arguments** begin on page 9 of this paper.

CHICAGO 302202v1 47079-00077

**AMENDMENTS TO THE CLAIMS**

Claims 1-21. (Cancelled)

22. (Withdrawn) A method for transferring gaming data on a global computer network comprising:

- receiving player identification information from outside of a gaming establishment;
- analyzing said player identification information;
- requesting player input regarding a random event;
- receiving and analyzing said input;
- generating a random number within said gaming establishment;
- interpreting said random number to determine a text or graphical outcome; and
- transmitting said outcome to a player through said global computer network.

23. (Withdrawn) The method of Claim 22, wherein said random event takes place in a microprocessor within a gaming machine located within said gaming establishment.

24. (Withdrawn) The method of Claim 22, wherein said random event takes place in a microprocessor within a gaming establishment server.

25. (Withdrawn) The method of Claim 22, wherein said global computer network is the Internet.

26. (Withdrawn) A method of receiving transferred data via a global computer network, comprising:

- accessing a global computer network from outside a gaming establishment;
- inputting identification information into said global computer network;
- gaining access to a server within said gaming establishment;
- requesting the generation of a random number, said random number being generated from within said gaming establishment; and
- receiving a text or graphical outcome of said random number generation via said global computer network.

27. (Withdrawn) The method of Claim 26, wherein said global computer network is the Internet.

28. (Withdrawn) The method of Claim 26, wherein said generation of said random number is accomplished at a gaming machine within said gaming establishment.

29. (Withdrawn) The method of Claim 26, wherein said generation of said random number is accomplished at a gaming establishment server.

30. (Withdrawn) The method of Claim 26, wherein the step of receiving is accomplished via said global computer network.

31. (Withdrawn) The method of Claim 26, wherein the step of receiving is accomplished through the Internet.

32. (Withdrawn) An interactive site on a global computer network comprising:  
a page including one or more game choices to allow a player to participate in a remote random event;  
data means to input data;  
outcome means to receive text or graphical outcomes of a remote random event; and  
notification means to notify said player of said outcomes.

33. (Withdrawn) The interactive web site of Claim 32, wherein said page is an Internet-based World Wide Web page.

34. (Withdrawn) The interactive web site of Claim 32, wherein said remote random event occurs in a slot machine.

Claims 35-36. (Cancelled)

37. (Currently Amended) A remote gaming method comprising:
- accessing, via a remote terminal, a gaming site on a global computer network connected to said remote terminal;
  - providing, via said remote terminal, personal identification information to said gaming site;
  - selecting, via said remote terminal, a game of chance ~~on a gaming machine~~ from a plurality of gaming machines located at a gaming establishment for remote play, said remote terminal being located outside said gaming establishment;
  - placing, via said remote terminal, a wager for playing said selected game; and
  - receiving randomly-generated text or graphical outcome data at said remote terminal for said selected game, said outcome data being generated by ~~the gaming machine~~ one of said plurality of gaming machines at said gaming establishment and relayed to said gaming site through a gaming server connected to said gaming site.
38. (Currently Amended) A remote gaming method using a gaming server, a remote terminal, and a gaming site on a global computer network, said gaming server being located at a gaming establishment, said remote terminal being located outside said gaming establishment, said gaming site being provided on said global computer network, the method comprising:
- receiving, at said gaming server, personal identification information, game selection information, and wager information from a player accessing said gaming site via said remote terminal, said remote terminal being connected to said global computer network;
  - randomly generating outcome data at ~~a gaming machine~~ one of a plurality of gaming machines communicatively coupled to said gaming server, said outcome data being generated for a game selected according to said game selection information, said ~~gaming machine~~ plurality of gaming machines being located at said gaming establishment;
  - receiving said outcome data at said gaming server; and
  - transmitting said outcome data from said gaming server to said gaming site for display to said player on said remote terminal in text or graphical form.

39. (Previously Presented) A method for playing a gaming machine located inside a gaming establishment from a remote terminal located outside the gaming establishment comprising:

- establishing a communication link between said remote terminal and a gaming site on a global computer network, said gaming site in communication with a gaming server for collecting outcome data from gaming machines located inside the gaming establishment;
- selecting a gaming machine at said gaming establishment using said remote terminal;
- making a wager to play the selected gaming machine;
- receiving outcome data, including game outcome, at said remote terminal resulting from a play of said gaming machine; and
- generating a payout if said game outcome meets predetermined criteria.

40. (Previously Presented) The method of claim 39 wherein said outcome data comprises information identifying the value of said payout; and further comprising the step of using said payout information to simulate a display of said game outcome at said remote location.

41. (Previously Presented) The method of claim 39 further comprising using said outcome data to simulate a display of said game outcome on said remote terminal.

42. (Previously Presented) The method of claim 39, wherein said selected gaming machine comprises a slot machine and wherein said game outcome data includes a reel position.

43. (Previously Presented) The method of claim 39 wherein said selected gaming machine comprises a video poker machine including a display for displaying a poker hand.

44. (Previously Presented) The method of claim 39 wherein said step of receiving outcome data includes receiving outcome data from a plurality of gaming machines for remote play.

45. (Previously Presented) The method of claim 44 wherein said step of receiving outcome data includes receiving a gaming machine identifier.

46. (Previously Presented) The method of claim 44 wherein said step of receiving outcome data includes receiving a gaming machine type.

47. (Previously Presented) The method of claim 44 wherein said step of receiving outcome data includes receiving player preferences.

48. (Previously Presented) The method of claim 39 wherein said selected gaming machine comprises a slot machine and wherein said game outcome comprises information identifying a reel position of said gaming machine; and further comprising the step of using said outcome information to display said reel position on said remote terminal.

49. (Previously Presented) The method of claim 39 and further including the steps of receiving a player identifier; and transmitting said player identifier for identification of said player.

50. (Previously Presented) The method of claim 39 wherein said game outcome results from the server initiating game play on the selected gaming machine.

51. (Previously Presented) The method of claim 39 wherein said game outcome results from the manual game play on the selected gaming machine.

52. (Previously Presented) A remote computer for the remote play of a local gaming machine located within a gaming establishment and connected to a gaming server, the remote computer being located outside said gaming establishment, said remote computer connected to a gaming site through a global computing network served by said gaming server, said remote computer comprising:

- a microprocessor;
- memory connected to said microprocessor and including instructions for controlling said microprocessor; and
- said microprocessor being operative with said instructions in said memory to:
  - receive information identifying a plurality of local gaming machines located within said gaming establishment from a gaming server;
  - transmit data selecting of at least one said plurality of local gaming machines for remote play;
  - receive a text or graphical outcome resulting from a local play of each said selected local gaming machine; and
  - generate a payout if said outcome meets predetermined criteria.

53. (Previously Presented) The remote computer of claim 52 wherein said selected gaming machine comprises a slot machine and wherein said outcome includes a reel position.

54. (Previously Presented) The remote computer of claim 52 wherein said operation of receiving information includes receiving information selecting at least two of said plurality of local gaming machines for remote play.

55. (Previously Presented) The remote computer of claim 52 wherein said operation of receiving information includes receiving a gaming machine identifier.

56. (Previously Presented) The remote computer of claim 52 wherein said operation of receiving information includes receiving a gaming machine type.

57. (Previously Presented) The remote computer of claim 52 wherein said operation of receiving information includes receiving player preferences.

58. (Previously Presented) The remote computer of claim 52 wherein said selected gaming machine comprises a video poker machine including a display for displaying a poker hand.

59. (Previously Presented) The remote computer of claim 52 wherein said outcome comprises data identifying the value of said payout; and further comprising the operation of using said payout data to simulate a display of said outcome at said remote location.

60. (Previously Presented) The remote computer of claim 52 wherein said outcome comprises information identifying a reel position of said selected gaming machine; and further comprising the operation of using said outcome data to display said reel position at said remote location.

61. (Previously Presented) The remote computer of claim 52 further including the operations of: receiving a player identifier; and transmitting said player identifier for identification of said player.

62. (Previously Presented) A remote computer located outside a gaming establishment, said gaming establishment having a plurality of gaming machines linked by a gaming server, said remote computer connected to a gaming site through a global computing network served by said gaming server comprising:

means for receiving information identifying a plurality of local gaming machines each engaged in play within said gaming establishment;

means for transmitting data from said remote computer for selecting at least one of said plurality of local gaming machines for information transfer;

means for receiving a text or graphical outcome resulting from a play of said selected local gaming machines; and

means for generating a payout if said outcome meets predetermined criteria.



**REMARKS**

Claims 37-62 were pending in this application. Claims 1-21, 35 and 36 were previously cancelled. Claims 22-34 were previously withdrawn. Claims 39-62 were previously added.

Claims 37 and 38 are currently amended in order to clarify that the game of chance is selected from a plurality of gaming machines residing at the gaming establishment. Support for the amendment may be found throughout the specification in general and at least on page 8, line 23 to page 9, line 2. No new matter was added.

**Claim Rejections Under 35 U.S.C. § 103(a)**

Claims 37-62 were rejected under 35 U.S.C. § 103(a) as being unpatentable over U.S. Patent No. 6,001,016 to Walker ("Walker") in view of U.S. Patent Nos. 6,409,602 to Wiltshire ("Wiltshire") and 6,183,366 to Goldberg ("Goldberg"). Claims 37 and 38 were further rejected under 35 U.S.C. § 103(a) as being unpatentable over U.S. Patent No. 6,012,984 to Roseman ("Roseman") in view of Goldberg. In each case, the Examiner states that a primary reference (Walker and Roseman) fails to disclose a communication link between the remote terminal and a gaming site, but that a secondary reference (Goldberg) teaches the communication link, and it would have been obvious to modify the primary references to include this aspect of the invention. The Applicant respectfully traverses these rejections on the basis that, even if there is motivation to combine (which there is not), significant claim features and limitations are still missing from the proposed combinations.

The Applicant's invention, as recited in independent claims 37-39, 52, and 62, is directed to a remote gaming method, and a computer therefor, where players at gaming terminals located outside a gaming establishment may play gaming machines located inside the gaming establishment. The invention allows players to play a real gaming machine (i.e., not a virtual gaming machine) without having to be present at the gaming establishment. Prior to the Applicant's invention, players had to actually travel to the gaming establishment in order to play a real gaming machine. As one might imagine, there are tremendous advantages to being able to play a real gaming machine from one's home, including savings in time, costs, and the overall convenience and comfort factor.

The Examiner contends that the Applicant's claimed invention is obvious. This, despite the fact that in the more than 10 years the Internet has been widely available, no one came up with the Applicant's invention. The closest thing that the Examiner has found so far is the remote gaming system of Walker. However, the Walker inventors also failed to come up with the claimed invention, even though the technological capability surely existed at the time Walker was filed. As explained in the previous response, Walker's "hopper" and "map" would seem to require that players actually be at the gaming establishment. Nowhere does Walker teach or suggest otherwise. Therefore, contrary to the Examiner's contention, Applicant respectfully submits that the claimed invention is anything but obvious.

In any case, combining Walker, Goldberg, and Wiltshire does not produce the claimed invention (the Roseman-Goldberg combination is addressed later herein). All of the independent claims (claims 37-39, 52, and 62) recite **two** intermediate nodes – a gaming server and a gaming site – between the gaming machine and the remote gaming terminal. The gaming machine generates outcome data (e.g., reel position, win/lose indicator, amount won or lost, etc.) and passes the data through the **two** intermediate nodes to the gaming terminal. The relevant portions of the claims are reproduced below for the Examiner's convenience. Note that claim 62 is written in means-plus-function form and must be construed under 35 U.S.C. § 112, ¶ 6, to cover the corresponding structures disclosed in the specification, including the gaming server and the gaming site.

Claim 37: "...receiving randomly-generated text or graphical outcome data at said remote terminal for said selected game, said outcome data being generated by the gaming machine at said gaming establishment and relayed to said **gaming site** through a **gaming server** connected to said gaming site."

Claim 38: "...transmitting said outcome data from said **gaming server** to said **gaming site** for display to said player on said remote terminal in text or graphical form."

Claim 39: "...said **gaming site** in communication with a **gaming server** for collecting outcome data from gaming machines located inside the gaming establishment..."

Claim 52 (preamble): "...said remote computer connected to a **gaming site** through a global computing network served by said **gaming server**..."

Claim 62: "...means for receiving a text or graphical outcome resulting from a play of said selected local gaming machines..."

Neither Walker, Goldberg, nor Wiltshire teaches the concept of using two intermediate nodes. On the contrary, Walker uses only one intermediate node, namely, a slot network server. (See, e.g., Walker, FIG. 1). Likewise, Goldberg also uses only one intermediate node, namely, a gaming site. As for Wiltshire, this reference does not appear to contain any intermediate nodes. (See, e.g., Wiltshire, FIG. 1D). Therefore, modifying Walker (a single-node system) with the teachings of Goldberg (another single-node system) and Wiltshire (a zero-node system) would produce a system that still has at most only one intermediate node.

The Examiner proposes to simply throw a couple of single-node systems together and thereby produce the two-node system of the claimed invention. However, when patentability turns on the question of obviousness, the mere fact that a device in a cited reference could have been modified to yield a device within the claimed invention does not make the modification obvious **unless the prior art suggested the desirability of the modification.** *In re Gordon*, 221 USPQ 1125, 1127 (Fed. Cir. 1984). The Examiner can satisfy the burden of showing the obviousness of the modification "only by showing some objective teaching in the prior art or that knowledge generally available to one of ordinary skill in the art would lead that individual to combine the relevant teachings of the references." *In re Fritch*, 23 USPQ2d 1780, 1783 (Fed. Cir. 1992).

In the present case, there is no motivation to add the Goldberg gaming site to the Walker system, at least not as a separate node. None of the references provide any reason or suggestion for keeping the gaming site separate from the slot network server. Moreover, the trend in high-technology has been steadily moving toward integration, not segregation. This is clearly seen from Goldberg itself in that the gaming site has a game controller incorporated in it, not as a separate node. (See Goldberg, FIG. 3). The numerous benefits of such integration are well-documented, including higher cost savings, better resource management, and a simpler, more streamlined approach overall. Therefore, if a person of ordinary skill in the art were to add the Goldberg gaming site to the Walker system, he or she would do so by combining the two nodes into one. Given the wholesale changes that would have to be made either way, there is little or no benefit to be gained by keeping them separate.

As for Roseman, this reference (like Wiltshire) also uses zero intermediate nodes. Therefore, the combination of Roseman and Goldberg would again not produce the two-node system of the claimed invention. And in any case, the only potential benefit to adding the Goldberg gaming site is to make Roseman's gaming machine/server accessible via html pages. However, Roseman's gaming machine/server is already accessible via html pages (see, e.g., col. 5, lines 12-45) and would derive little or no benefit from the addition of the Goldberg gaming site. Indeed, the Examiner's proposed combination might negate the advantages of having a single, integrated gaming machine/server generate the html pages in the first place, including the advantage of reducing the total number of machines/servers needed. Therefore, the Applicant respectfully submits no person of ordinary skill in the art would follow the course outlined by the Examiner.

Nevertheless, in order to expedite allowance of this application, claims 37 and 38 have been amended to clarify that the game of chance is selected from a **plurality of gaming machines** residing at the gaming establishment. Both Roseman and Goldberg teach a single gaming machine, i.e., a game server in Roseman and a game controller in Goldberg. Therefore, even if there is motivation to combine, the combination of Roseman and Goldberg would not produce the invention as now claimed in amended claims 37 and 38.

Accordingly, for at least the reasons stated above, withdrawal of the rejections against independent claims 37-39, 52, and 62 under 35 U.S.C. § 103(a) is respectfully requested.

As for claims 40-51 and 53-61, although they may recite independently allowable subject matter, these claims depend from independent claims 37-39, 52, and 62, and are therefore allowable for at least the reasons stated above.

Application No.: 09/688501

Docket No.: 47079-00077USPT

**CONCLUSION**

In view of the above, the Applicant believes this response to be in compliance and each of the presently pending claims in this application is believed to be in immediate condition for allowance. Accordingly, the Examiner is respectfully requested to pass this application to issue.

Dated: January 18, 2005

Respectfully submitted,

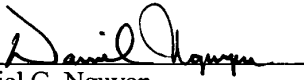
By 

Daniel G. Nguyen

Registration No.: 42,933

JENKENS & GILCHRIST, A PROFESSIONAL  
CORPORATION

225 W. Washington, Ste. 2600

Chicago, Illinois 60606-3418

(713) 951-3354

(713) 951-3314 Facsimile

Attorneys For Applicant

**PATENT APPLICATION FEE DETERMINATION RECORD**  
Effective October 1, 2001

Application or Docket Number

09/688,501

**CLAIMS AS FILED - PART I**

	(Column 1)	(Column 2)
TOTAL CLAIMS		
FOR	NUMBER FILED	NUMBER EXTRA
TOTAL CHARGEABLE CLAIMS	39	minus 20 =
INDEPENDENT CLAIMS	8	minus 3 =
MULTIPLE DEPENDENT CLAIM PRESENT	<input type="checkbox"/>	

\* If the difference in column 1 is less than zero, enter "0" in column 2

**CLAIMS AS AMENDED - PART II**

9/10/04

	(Column 1)	(Column 2)	(Column 3)
AMENDMENT A	CLAIMS REMAINING AFTER AMENDMENT	HIGHEST NUMBER PREVIOUSLY PAID FOR	PRESENT EXTRA
Total	39	minus 39	= -
Independent	8	minus 8	= -
FIRST PRESENTATION OF MULTIPLE DEPENDENT CLAIM	<input type="checkbox"/>		

	(Column 1)	(Column 2)	(Column 3)
AMENDMENT B	CLAIMS REMAINING AFTER AMENDMENT	HIGHEST NUMBER PREVIOUSLY PAID FOR	PRESENT EXTRA
Total	39	minus 39	= -
Independent	8	minus 8	= -
FIRST PRESENTATION OF MULTIPLE DEPENDENT CLAIM	<input type="checkbox"/>		

1-21-05

	(Column 1)	(Column 2)	(Column 3)
AMENDMENT C	CLAIMS REMAINING AFTER AMENDMENT	HIGHEST NUMBER PREVIOUSLY PAID FOR	PRESENT EXTRA
Total	38	minus 39	= -
Independent	8	minus 8	= -
FIRST PRESENTATION OF MULTIPLE DEPENDENT CLAIM	<input type="checkbox"/>		

\* If the entry in column 1 is less than the entry in column 2, write "0" in column 3.  
 \* If the "Highest Number Previously Paid For" in THIS SPACE is less than 20, enter "20."  
 \* If the "Highest Number Previously Paid For" in THIS SPACE is less than 3, enter "3."  
 The "Highest Number Previously Paid For" (Total or Independent) is the highest number found in the appropriate box in column 1.

**SMALL ENTITY TYPE  OR OTHER THAN SMALL ENTITY**

RATE	FEE	OR	RATE	FEE
BASIC FEE	370.00	OR	BASIC FEE	740.00
X\$ 9=		OR	X\$18=	
X42=		OR	X84=	
+140=		OR	+280=	
TOTAL	pd	OR	TOTAL	pd

SMALL ENTITY OR OTHER THAN SMALL ENTITY

RATE	ADDITIONAL FEE	OR	RATE	ADDITIONAL FEE
X\$ 9=		OR	X\$18=	
X42=		OR	X84=	
+140=		OR	+280=	
TOTAL ADDIT. FEE		OR	TOTAL ADDIT. FEE	

RATE	ADDITIONAL FEE	OR	RATE	ADDITIONAL FEE
X\$ 9=		OR	X\$18=	
X42=		OR	X84=	
+140=		OR	+280=	
TOTAL ADDIT. FEE		OR	TOTAL ADDIT. FEE	

RATE	ADDITIONAL FEE	OR	RATE	ADDITIONAL FEE
X\$ 9=		OR	X\$18=	
X42=		OR	X84=	
+140=		OR	+280=	
TOTAL ADDIT. FEE		OR	TOTAL ADDIT. FEE	

RECT AVAIL ARLE PDV



UNITED STATES PATENT AND TRADEMARK OFFICE

UNITED STATES DEPARTMENT OF COMMERCE  
United States Patent and Trademark Office  
Address: COMMISSIONER FOR PATENTS  
P.O. Box 1450  
Alexandria, Virginia 22313-1450  
www.uspto.gov

APPLICATION NO.	FILING DATE	FIRST NAMED INVENTOR	ATTORNEY DOCKET NO.	CONFIRMATION NO.
09/688,501	10/16/2000	Shridhar P. Joshi	47079-00077	3225
30223	7590	04/20/2005	EXAMINER RADA, ALEX P	
JENKENS & GILCHRIST, P.C. 225 WEST WASHINGTON SUITE 2600 CHICAGO, IL 60606			ART UNIT	
			PAPER NUMBER 3714	

DATE MAILED: 04/20/2005

Please find below and/or attached an Office communication concerning this application or proceeding.

52

<b>Office Action Summary</b>	<b>Application No.</b> 09/688,501	<b>Applicant(s)</b> JOSHI, SHRIDHAR P.	
	<b>Examiner</b> Alex P. Rada	<b>Art Unit</b> 3714	

-- The MAILING DATE of this communication appears on the cover sheet with the correspondence address --

**Period for Reply**

A SHORTENED STATUTORY PERIOD FOR REPLY IS SET TO EXPIRE 3 MONTH(S) FROM THE MAILING DATE OF THIS COMMUNICATION.

- Extensions of time may be available under the provisions of 37 CFR 1.136(a). In no event, however, may a reply be timely filed after SIX (6) MONTHS from the mailing date of this communication.
- If the period for reply specified above is less than thirty (30) days, a reply within the statutory minimum of thirty (30) days will be considered timely.
- If NO period for reply is specified above, the maximum statutory period will apply and will expire SIX (6) MONTHS from the mailing date of this communication.
- Failure to reply within the set or extended period for reply will, by statute, cause the application to become ABANDONED (35 U.S.C. § 133). Any reply received by the Office later than three months after the mailing date of this communication, even if timely filed, may reduce any earned patent term adjustment. See 37 CFR 1.704(b).

**Status**

- 1)  Responsive to communication(s) filed on 21 January 2005.
- 2a)  This action is FINAL.
- 2b)  This action is non-final.
- 3)  Since this application is in condition for allowance except for formal matters, prosecution as to the merits is closed in accordance with the practice under *Ex parte Quayle*, 1935 C.D. 11, 453 O.G. 213.

**Disposition of Claims**

- 4)  Claim(s) 22-34 and 37-62 is/are pending in the application.
  - 4a) Of the above claim(s) 22-34 is/are withdrawn from consideration.
- 5)  Claim(s) \_\_\_\_\_ is/are allowed.
- 6)  Claim(s) 37-62 is/are rejected.
- 7)  Claim(s) \_\_\_\_\_ is/are objected to.
- 8)  Claim(s) \_\_\_\_\_ are subject to restriction and/or election requirement.

**Application Papers**

- 9)  The specification is objected to by the Examiner.
- 10)  The drawing(s) filed on \_\_\_\_\_ is/are: a)  accepted or b)  objected to by the Examiner.  
Applicant may not request that any objection to the drawing(s) be held in abeyance. See 37 CFR 1.85(a).  
Replacement drawing sheet(s) including the correction is required if the drawing(s) is objected to. See 37 CFR 1.121(d).
- 11)  The oath or declaration is objected to by the Examiner. Note the attached Office Action or form PTO-152.

**Priority under 35 U.S.C. § 119**

- 12)  Acknowledgment is made of a claim for foreign priority under 35 U.S.C. § 119(a)-(d) or (f).
    - a)  All    b)  Some \*    c)  None of:
      - 1.  Certified copies of the priority documents have been received.
      - 2.  Certified copies of the priority documents have been received in Application No. \_\_\_\_\_.
      - 3.  Copies of the certified copies of the priority documents have been received in this National Stage application from the International Bureau (PCT Rule 17.2(a)).
- \* See the attached detailed Office action for a list of the certified copies not received.

**Attachment(s)**

- 1)  Notice of References Cited (PTO-892)
- 2)  Notice of Draftsperson's Patent Drawing Review (PTO-948)
- 3)  Information Disclosure Statement(s) (PTO-1449 or PTO/SB/08)  
Paper No(s)/Mail Date \_\_\_\_\_.
- 4)  Interview Summary (PTO-413)  
Paper No(s)/Mail Date. \_\_\_\_\_.
- 5)  Notice of Informal Patent Application (PTO-152)
- 6)  Other: \_\_\_\_\_.



**DETAILED ACTION**

***Response to Amendment***

In response to the amendment filed January 21, 2005 in which the applicant withdraws claims 22-34, previously canceled claims 1-21 and 35-36, amends claims 37-38, and claims 37-62 are pending in this office action.

***Claim Rejections - 35 USC § 103***

1. The following is a quotation of 35 U.S.C. 103(a) which forms the basis for all obviousness rejections set forth in this Office action:

(a) A patent may not be obtained though the invention is not identically disclosed or described as set forth in section 102 of this title, if the differences between the subject matter sought to be patented and the prior art are such that the subject matter as a whole would have been obvious at the time the invention was made to a person having ordinary skill in the art to which said subject matter pertains. Patentability shall not be negatived by the manner in which the invention was made.

2. Claims 37-38 are rejected under 35 U.S.C. 103(a) as being unpatentable over Wiltshire et al. (US 6,409,602) in view of Paravia et al. (US 6,508,710).

3. Wiltshire et al discloses the following:

Accessing via a remote terminal (client/terminal), a gaming site (310 of figure 3) on a global computer network (column 8, lines 15-34) connected to the remote terminal (client/terminal), selecting a game of chance from a plurality of gaming machine located at a gaming establishment for remote play (figures 4b-9D), the remote terminal being located outside the gaming establishment, placing a wager for playing the selected game and receiving randomly-generated text or graphical outcome data at the remote terminal for the selected game the outcome data being generated by one of the plurality of gaming machines at the gaming

establishment and relayed to the gaming site through a gaming server connected to the gaming site, in which the examiner interprets the server/host containing the different programs and data of the different chance game to be a functional equivalent to placing a wager for playing the selected game and receiving randomly-generated text or graphical outcome data at the remote terminal for the selected game the outcome data being generated by one of the plurality of gaming machines at the gaming establishment and relayed to the gaming site through a gaming server connected to the gaming site (column 7, lines 7-56 and figures 2-3) as recited in claims 37-38.

Wiltshire et al does expressly disclose the following:

Providing via the remote terminal, personal identification information to the gaming site as recited in claims 37-38.

Paravia et al teaches the following:

Providing via the remote terminal, personal identification information to the gaming site (column 6, lines 49-55 and item 142 of figure 2) as recited in claims 37-38. By having providing personal identification information to the gaming site, one of ordinary skill in the art would provide a verification and permission to game players that are permitted to play.

Therefore, it would have been obvious to one of ordinary skill in the art at the time of the invention was made to modify Wiltshire et al to include personal identification information to the gaming site as taught Paravia et al to provide a verification and permission to game players that are permitted to play.

4. Claims 39-62 are rejected under 35 U.S.C. 103(a) as being unpatentable over Wiltshire et al. (US 6,409,602) in view of Walker et al. (US 6,001,016).
5. Wiltshire et al discloses the following:

Establishing a communication link between the remote terminal (client/terminal) and a gaming site (310 of figure 3) on a global computer network (column 8, lines 15-34), the gaming site in communication with a gaming server (server/host), selecting a gaming machine (figures 4B-9D) at the gaming establishment using the remote terminal, making a wager to play the selected gaming machine, receiving outcome data, including game outcome at the remote terminal resulting from a play of the gaming machine (figures 4B-9D), and generating a payout if the game outcome meets predetermined criteria (figure 4B, column 7, lines 7-56, and column 8, lines 15-34) as recited in claim 39.

The game outcome resulting from the server initiating game play on the selected gaming machine (column 8, lines 42-65) as recited in claim 50.

The remote computer having a microprocessor, memory connected to the microprocessor and including instructions for controlling the microprocessor, and the microprocessor being operative with the instructions in the memory to receive information identifying a plurality of local gaming machine located within the gaming establishment from a gaming server, receive a text or graphical outcome resulting from a local play of each of the selected gaming machines and generate payout if the outcome meets predetermined criteria (figures 4B-9D, column 6, line 44 – column 7, line 6, column 7, lines 7-56, and column 8, lines 15-34) as recited in claim 52.

The gaming server having means for receiving information identifying a plurality of gaming machines (figures 4B-9D) each engaged in play within the gaming establishment, means for receiving a text or graphical outcome resulting from a ply of the selected gaming machines and means for generating a payout if the outcome meets predetermined criteria (figures 4B-9D, column 6, line 44 – column 7, line 6, column 7, lines 7-56, and column 8, lines 15-34) as recited in claim 62.

Wiltshire et al does not expressly disclose the following:

The gaming server collecting outcome data from the gamine machines located inside the gaming establishment as recited in claims 39, 52 and 62.

The outcome data having information identifying the value of the payout and simulate a display of the game outcome at the remote location as recited in claims 40 and 59.

The outcome data to simulate a display of the game outcome on the remote terminal as recited in claim 41.

The selected gaming machine is a slot machine wherein the outcome data includes reel position as recited in claims 42, 48, 53, and 60.

The selected gaming machine is a video poker machine including a display for displaying a poker hand as recited in claims 43 and 58.

The receiving outcome data includes receiving outcome data from a plurality of gaming machine form remote play as recited in claim 44.

The outcome data includes a gaming machine identifier and gaming machine type as recited in claim 45-46 and 55-56.

The outcome data including receiving player preferences as recited in claims 47 and 57.

A player identifier and transmitting the player identifier for identification of the player as recited in claims 49 and 61.

Walker et al teaches the following:

The gaming server collecting outcome data from the gaming machines located inside the gaming establishment (figure 1) as recited in claims 39, 52 and 62.

The outcome data having information identifying the value of the payout and simulate a display of the game outcome at the remote location (column 5, lines 33-37) as recited in claims 40 and 59.

The outcome data to simulate a display of the game outcome on the remote terminal (column 5, lines 33-37) as recited in claim 41.

The selected gaming machine is a slot machine wherein the outcome data includes reel position (column 5, lines 33-37) as recited in claims 42, 48, 53-54, and 60.

The selected gaming machine is a video poker machine including a display for displaying a poker hand (column 5, lines 33-37) as recited in claims 43 and 58.

The receiving outcome data includes receiving outcome data from a plurality of gaming machine form remote play (column 6, lines 45-56) as recited in claim 44.

The outcome data includes a gaming machine identifier and gaming machine type (figure 5 and column 6, lines 31-44) as recited in claim 45-46 and 55-56.

The outcome data including receiving player preferences (column 6, lines 8-30) as recited in claims 47 and 57.

A player identifier and transmitting the player identifier for identification of the player (column 6, lines 8-30) as recited in claims 49 and 61.

The outcome results from the manual game play on the selected gaming machine (summary) as recited in claim 51. By transmitting data from the gaming machine located in the gaming establishment, one of ordinary skill in the art would provide a system that does not require human intervention and live video transmission of the game being played.

Therefore, it would have been obvious to one of ordinary skill in the art at the time of the invention was made to modify Wiltshire et al to include the gaming server collecting outcome data from the gaming machines located inside the gaming establishment, the outcome data having information identifying the value of the payout and simulate a display of the game outcome at the remote location, the outcome data to simulate a display of the game outcome on the remote terminal, the selected gaming machine is a slot machine wherein the outcome data includes reel position, the selected gaming machine is a video poker machine including a display for displaying a poker hand, the receiving outcome data includes receiving outcome data from a plurality of gaming machine form remote play, the outcome data includes a gaming machine identifier and gaming

machine type, the outcome data including receiving player preferences, and a player identifier and transmitting the player identifier for identification of the player as taught by Walker et al to provide a system that does not require human intervention and live video transmission of the game being played.

*Response to Arguments*

6. Applicant's arguments with respect to claims 37-62 have been considered but are moot in view of the new ground(s) of rejection.

*Conclusion*

Any inquiry concerning this communication or earlier communications from the examiner should be directed to Alex P. Rada whose telephone number is 571-272-4452. The examiner can normally be reached on Monday - Friday, 08:00-16:00.

If attempts to reach the examiner by telephone are unsuccessful, the examiner's acting supervisor, Jessica Harrison can be reached on 571-272-4449. The fax phone number for the organization where this application or proceeding is assigned is 703-872-9306.

APR  
APR

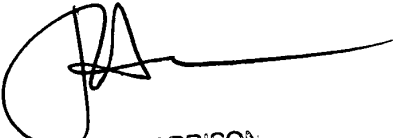

JESSICA HARRISON  
PRIMARY EXAMINER

<b>Notice of References Cited</b>	Application/Control No. 09/688,501	Applicant(s)/Patent Under Reexamination JOSHI, SHRIDHAR P.	
	Examiner Alex P. Rada	Art Unit 3714	Page 1 of 1

**U.S. PATENT DOCUMENTS**

*	Document Number Country Code-Number-Kind Code	Date MM-YYYY	Name	Classification
A	US-6,409,602	06-2002	Wiltshire et al.	463/42
B	US-6,508,710	01-2003	Paravia et al.	463/42
C	US-6,001,016	12-1999	Walker et al.	463/42
D	US-			
E	US-			
F	US-			
G	US-			
H	US-			
I	US-			
J	US-			
K	US-			
L	US-			
M	US-			

**FOREIGN PATENT DOCUMENTS**

*	Document Number Country Code-Number-Kind Code	Date MM-YYYY	Country	Name	Classification
N					
O					
P					
Q					
R					
S					
T					

**NON-PATENT DOCUMENTS**

*	Include as applicable: Author, Title Date, Publisher, Edition or Volume, Pertinent Pages)
U	
V	
W	
X	

\*A copy of this reference is not being furnished with this Office action. (See MPEP § 707.05(a).)  
Dates in MM-YYYY format are publication dates. Classifications may be US or foreign.



**Index of Claims**



Application No.

09/688,501

Examiner

Alex P. Rada

Applicant(s)

JOSHI, SHRIDHAR P.

Art Unit

3714

√	Rejected
=	Allowed

-	(Through numeral) Cancelled
+	Restricted

N	Non-Elected
I	Interference

A	Appeal
O	Objected

Claim		Date			
Final	Original	4/13/05			
1					
2					
3					
4					
5					
6					
7					
8					
9					
10					
11					
12					
13					
14					
15					
16					
17					
18					
19					
20					
21					
22	N				
23	N				
24	N				
25	N				
26	N				
27	N				
28	N				
29	N				
30	N				
31	N				
32	N				
33	N				
34	N				
35					
36					
37	√				
38	√				
39	√				
40	√				
41	√				
42	√				
43	√				
44	√				
45	√				
46	√				
47	√				
48	√				
49	√				
50	√				

Claim		Date			
Final	Original	4/13/05			
51	√				
52	√				
53	√				
54	√				
55	√				
56	√				
57	√				
58	√				
59	√				
60	√				
61	√				
62	√				
63					
64					
65					
66					
67					
68					
69					
70					
71					
72					
73					
74					
75					
76					
77					
78					
79					
80					
81					
82					
83					
84					
85					
86					
87					
88					
89					
90					
91					
92					
93					
94					
95					
96					
97					
98					
99					
100					

Claim		Date			
Final	Original				
101					
102					
103					
104					
105					
106					
107					
108					
109					
110					
111					
112					
113					
114					
115					
116					
117					
118					
119					
120					
121					
122					
123					
124					
125					
126					
127					
128					
129					
130					
131					
132					
133					
134					
135					
136					
137					
138					
139					
140					
141					
142					
143					
144					
145					
146					
147					
148					
149					
150					

**Search Notes**

Application No.

09/688,501

Applicant(s)

JOSHI, SHRIDHAR P.

Examiner

Alex P. Rada

Art Unit

3714

**SEARCHED**

Class	Subclass	Date	Examiner
463	16-25 29	6/24/2004	APR
	40-42		
Search	Updated	4/13/2005	APR

**INTERFERENCE SEARCHED**

Class	Subclass	Date	Examiner

**SEARCH NOTES  
(INCLUDING SEARCH STRATEGY)**

	DATE	EXMR

3114

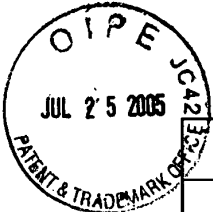

<b>AMENDMENT TRANSMITTAL LETTER</b>			Docket No. 47079-00077USPT	
Application No. 09/688501	Filing Date October 16, 2000	Examiner A. P. Rada	Art Unit 3714	

Applicant(s): Shridhar P. Joshi

Invention: METHOD OF TRANSFERRING GAMING DATA ON A GLOBAL COMPUTER NETWORK

**TO THE COMMISSIONER FOR PATENTS**

Transmitted herewith is an amendment in the above-identified application.  
The fee has been calculated and is transmitted as shown below.

CLAIMS AS AMENDED					
	Claims Remaining After Amendment	Highest Number Previously Paid	Number Extra Claims Present	Rate	
Total Claims	26	- 36 =	0	x	0
Independent Claims	5	- 8 =	0	x	0
Multiple Dependent Claims (check if applicable) <input type="checkbox"/>					
Other fee (please specify):					
<b>TOTAL ADDITIONAL FEE FOR THIS AMENDMENT:</b>					0.00

- Large Entity  Small Entity
- No additional fee is required for this amendment.
- Please charge Deposit Account No. \_\_\_\_\_ in the amount of \$ \_\_\_\_\_  
A duplicate copy of this sheet is enclosed.
- A check in the amount of \$ \_\_\_\_\_ to cover the filing fee is enclosed.
- Payment by credit card. Form PTO-2038 is attached.
- The Director is hereby authorized to charge and credit Deposit Account No. 10-0447  
as described below. A duplicate copy of this sheet is enclosed.
- Credit any overpayment.
- Charge any additional filing or application processing fees required under 37 CFR 1.16 and 1.17.

Daniel G. Nguyen Dated: July 20, 2005  
Daniel G. Nguyen  
Attorney Reg. No.: 42,933

JENKENS & GILCHRIST, A PROFESSIONAL CORPORATION  
225 W. Washington, Ste. 2600  
Chicago, Illinois 60606-3418  
(312) 425-8513

I hereby certify that this correspondence is being deposited with the U.S. Postal Service with sufficient postage as First Class Mail, in an envelope addressed to: MS Amendment, Commissioner for Patents, P.O. Box 1450, Alexandria, VA 22313-1450, on the date shown below.

Dated: July 20, 2005 Signature: Gwen Landry-Witt (Gwen J. Landry-Witt)



I hereby certify that this correspondence is being deposited with the U.S. Postal Service with sufficient postage as First Class Mail, in an envelope addressed to: MS Amendment, Commissioner for Patents, P.O. Box 1450, Alexandria, VA 22313-1450, on the date shown below.

Dated: July 20, 2005

Signature

*Gwendolyn Landry-Witt*  
(Gwendolyn Landry-Witt)

Docket No.: 47079-00077USPT  
(PATENT)

**IN THE UNITED STATES PATENT AND TRADEMARK OFFICE**

In re Patent Application of:  
Shridhar P. Joshi

Confirmation No: 3225

Application No.: 09/688501

Art Unit: 3714

Filed: October 16, 2000

Examiner: Alex P. Rada

For: METHOD OF TRANSFERRING GAMING  
DATA ON A GLOBAL COMPUTER  
NETWORK

**RESPONSE TO NON-FINAL OFFICE ACTION**

MS Amendment  
Commissioner for Patents  
P.O. Box 1450  
Alexandria, VA 22313-1450

Dear Sir:

**INTRODUCTORY COMMENTS**

Responsive to the Communication mailed April 20, 2005, reconsideration and allowance of the present application is respectfully requested in view of the following remarks.

**Remarks/Arguments** begin on page 2 of this paper.

**REMARKS**

Claims 37-62 were pending in this application. No claims were added, amended, or cancelled. Hence, claims 37-62 remain pending in this application. A copy of the currently pending claims is provided in the Appendix for the convenience of the Examiner.

Claims 22-36 were previously cancelled in response to a Restriction Requirement dated August 30, 2002. Therefore, Applicant has changed their status identifiers from "Withdrawn" to "Cancelled" in order to reflect the cancelled status.

**Claim Rejections Under 35 U.S.C. § 103(a)**

Independent claims 37-38 were rejected under 35 U.S.C. § 103(a) as being unpatentable over the combination of U.S. Patent Nos. 6,409,602 to Wiltshire et al. ("Wiltshire") and 6,580,710 to Paravia et al. ("Paravia"). The Examiner states that Wiltshire discloses each element of these claims except for the provision of personal identification information to the gaming sites via the remote terminal. The Examiner contends, however, that Paravia teaches this aspect of the invention, and that it would have been obvious to combine Wiltshire and Paravia to arrive at the claimed invention.

Claims 39-62 were rejected under 35 U.S.C. § 103(a) as being unpatentable over the combination of Wiltshire and U.S. Patent No. 6,001,016 to Walker ("Walker"). With respect to independent claims 39, 52, and 62, the Examiner states that Wiltshire discloses each element of these claims except for the collection of outcome data from the gaming machines located in the gaming establishment. The Examiner contends, nevertheless, that Walker teaches this aspect of the invention, and that it would have been obvious to combine Wiltshire and Walker to arrive at the claimed invention.

Applicant respectfully traverses these rejections on the basis that, even if there is motivation to combine the above references (which there is not), significant claim features and limitations are still missing from the proposed combinations.

**Arguments in Support of the Claims**

Applicant's invention, as recited in independent claims 37-39, 52, and 62, is directed to a remote gaming method, and a computer therefor, where players at gaming terminals located

outside a gaming establishment may play gaming machines located in the gaming establishment. As Applicant tried to explain in the previous response, the invention allows players to play a real gaming machine (i.e., not a virtual gaming machine) without having to be present at the gaming establishment. There are tremendous advantages to being able to play a real gaming machine without having to be present at the gaming establishment, including the benefits of reduced time, cost, and the overall convenience and comfort factor.

The Examiner contends that Wiltshire discloses each element of independent claims 37-39, 52, and 62 except for the aspects mentioned above, but that these aspects are obvious in light of Paravia and Walker. Applicant respectfully disagrees.

The most glaring defect in Wiltshire is the lack of a gaming site, as recited in the independent claims. The Examiner attempts to convert the “access website” 310 in FIG. 3 of Wiltshire into a gaming site. *Office Action, pages 2 and 4*. However, the access website 310 is merely a software download site for downloading the Wiltshire installation software. Once the software is installed, the website 310 contributes nothing else to Wiltshire (i.e., provides no gaming data or information to the client/terminal), as is abundantly clear from FIG. 3 and the accompanying text.

Indeed, Wiltshire actually distinguishes its system from website-based casino games in the Background section. For example, Wiltshire discusses the operation of non-website-based gaming stations versus casino gaming websites, concluding that existing non-website-based gaming stations are inferior because the gaming program is executed only on the individual gaming stations. *Col. 1, line 51 to col. 2, line 13*. (Wiltshire then explains in the Summary section that its gaming stations are an improvement because they use a gaming program that is executed on a server/host computer.) Thus, a person of ordinary skill in the art reading Wiltshire would have the perception that Wiltshire is actually distinguishable over website-based casino games.

Other differences between the claimed invention and Wiltshire include the use of **two separate intermediate nodes** – a gaming server and a gaming site – between the gaming machines and the remote gaming terminal. That is, the outcome data from the gaming machines passes through **two separate intermediate nodes** before arriving at the gaming terminal. Wiltshire fails to disclose any intermediate nodes, since the outcome data travels directly from

the host/server computer (which the Examiner compares to the claimed gaming machines) to the client/terminals. *See, e.g., Wiltshire's FIG. 1.*

In any event, there is a fundamental difference between Wiltshire and the claimed invention, namely, the use of actual gaming machines in the claimed invention versus a virtual gaming machine in Wiltshire. The Examiner glosses over this important distinction by saying that a host/server computer executing casino game programs is **functionally equivalent** to gaming machines in a gaming establishment. Applicant respectfully submits that the Examiner has failed to meet the criteria for raising such a functional equivalency rejection.

According to MPEP 2144.06, a functional equivalent must be recognized in the prior art and may not be based on the mere fact that the components are functional or mechanical equivalents:

**In order to rely on equivalence as a rationale supporting an obviousness rejection, the equivalency must be recognized in the prior art, and cannot be based on applicant's disclosure or the mere fact that the components at issue are functional or mechanical equivalents.** *In re Ruff*, 256 F.2d 590, 118 USPQ 340 (CCPA 1958) (The mere fact that components are claimed as members of a Markush group cannot be relied upon to establish the equivalency of these components. However, an applicant's expressed recognition of an art-recognized or obvious equivalent may be used to refute an argument that such equivalency does not exist.); *In re Scott*, 323 F.2d 1016, 139 USPQ 297 (CCPA 1963) (Claims were drawn to a hollow fiberglass shaft for archery and a process for the production thereof where the shaft differed from the prior art in the use of a paper tube as the core of the shaft as compared with the light wood or hardened foamed resin core of the prior art. The Board found the claimed invention would have been obvious, reasoning that the prior art foam core is the functional and mechanical equivalent of the claimed paper core. The court reversed, holding that components which are functionally or mechanically equivalent are not necessarily obvious in view of one another, and in this case, the use of a light wood or hardened foam resin core does not fairly suggest the use of a paper core.); *Smith v. Hayashi*, 209 USPQ 754 (Bd. of Pat. Inter. 1980) (The mere fact that phthalocyanine and selenium function as equivalent photoconductors in the claimed environment was not sufficient to establish that one would have been obvious over the other. However, there was evidence that both phthalocyanine and selenium were known photoconductors in the art of electrophotography. "This, in our view, presents strong evidence of obviousness in substituting one for the other in an electrophotographic environment as a photoconductor." 209 USPQ at 759.).

(MPEP 2144.06, emphasis added).

In the present case, nothing in Wiltshire suggests that a virtual gaming machine is functionally equivalent to an actual gaming machine in a gaming establishment. The Examiner has not produced any evidence from Wiltshire or any other art of record that a person of ordinary skill in the art recognizes a virtual gaming machine to be functionally equivalent to a gaming

machine in a gaming establishment. Without this evidence, Applicant respectfully submits there can be no basis for a rejection under functional equivalency.

Moreover, Applicant respectfully submits that the principle of functional equivalency is misapplied here. Functional equivalency is properly applied where two components are physical equivalents, either mechanically, chemically, or the like. *See MPEP 2144.06.* Otherwise, all simulations would be functional equivalents of their actual counterparts, and vice versa. For example, under the Examiner's assertion, a tank simulation/training system would be functionally equivalent to the operation of a real tank by the U.S. Army and, hence, not patentable. Wiltshire itself would be a functional equivalent of existing gaming machines and therefore not patentable.

Accordingly, based on the foregoing Wiltshire defects, even if there is motivation to combine Wiltshire with Paravia and/or Walker in the manner urged by the Examiner, the resulting combination would still not produce the claimed invention. Thus, withdrawal of the rejections against independent claims 37-39, 52, and 62 is respectfully requested.

As for dependent claims 40-51 and 53-61, although they may recite independently allowable subject matter, these claims depend from the independent claims and are therefore allowable for at least the same reasons. Accordingly, withdrawal of the rejections against the dependent claims is also respectfully requested.

### CONCLUSION

In view of the above, Applicant believes each of the presently pending claims in this application is believed to be in immediate condition for allowance.

Dated: July 20, 2005

Respectfully submitted,

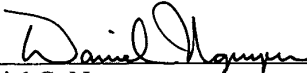
By 

Daniel G. Nguyen

Registration No.: 42,933

JENKENS & GILCHRIST, A PROFESSIONAL CORPORATION

225 W. Washington, Ste. 2600

Chicago, Illinois 60606-3418

(713) 951-3354

(713) 951-3314 Facsimile

Attorneys For Applicant

5



**APPENDIX**

Claims 1-36. (Cancelled)

37. (Previously Presented) A remote gaming method comprising:
- accessing, via a remote terminal, a gaming site on a global computer network connected to said remote terminal;
  - providing, via said remote terminal, personal identification information to said gaming site;
  - selecting, via said remote terminal, a game of chance from a plurality of gaming machines located at a gaming establishment for remote play, said remote terminal being located outside said gaming establishment;
  - placing, via said remote terminal, a wager for playing said selected game; and
  - receiving randomly-generated text or graphical outcome data at said remote terminal for said selected game, said outcome data being generated by one of said plurality of gaming machines at said gaming establishment and relayed to said gaming site through a gaming server connected to said gaming site.
38. (Previously Presented) A remote gaming method using a gaming server, a remote terminal, and a gaming site on a global computer network, said gaming server being located at a gaming establishment, said remote terminal being located outside said gaming establishment, said gaming site being provided on said global computer network, the method comprising:
- receiving, at said gaming server, personal identification information, game selection information, and wager information from a player accessing said gaming site via said remote terminal, said remote terminal being connected to said global computer network;
  - randomly generating outcome data at one of a plurality of gaming machines communicatively coupled to said gaming server, said outcome data being generated for a game selected according to said game selection information, said plurality of gaming machines being located at said gaming establishment;
  - receiving said outcome data at said gaming server; and
  - transmitting said outcome data from said gaming server to said gaming site for display to said player on said remote terminal in text or graphical form.

39. (Previously Presented) A method for playing a gaming machine located inside a gaming establishment from a remote terminal located outside the gaming establishment comprising:
- establishing a communication link between said remote terminal and a gaming site on a global computer network, said gaming site in communication with a gaming server for collecting outcome data from gaming machines located inside the gaming establishment;
  - selecting a gaming machine at said gaming establishment using said remote terminal;
  - making a wager to play the selected gaming machine;
  - receiving outcome data, including game outcome, at said remote terminal resulting from a play of said gaming machine; and
  - generating a payout if said game outcome meets predetermined criteria.
40. (Previously Presented) The method of claim 39 wherein said outcome data comprises information identifying the value of said payout; and further comprising the step of using said payout information to simulate a display of said game outcome at said remote location.
41. (Previously Presented) The method of claim 39 further comprising using said outcome data to simulate a display of said game outcome on said remote terminal.
42. (Previously Presented) The method of claim 39, wherein said selected gaming machine comprises a slot machine and wherein said game outcome data includes a reel position.
43. (Previously Presented) The method of claim 39 wherein said selected gaming machine comprises a video poker machine including a display for displaying a poker hand.
44. (Previously Presented) The method of claim 39 wherein said step of receiving outcome data includes receiving outcome data from a plurality of gaming machines for remote play.
45. (Previously Presented) The method of claim 44 wherein said step of receiving outcome data includes receiving a gaming machine identifier.
46. (Previously Presented) The method of claim 44 wherein said step of receiving outcome data includes receiving a gaming machine type.
47. (Previously Presented) The method of claim 44 wherein said step of receiving outcome data includes receiving player preferences.

48. (Previously Presented) The method of claim 39 wherein said selected gaming machine comprises a slot machine and wherein said game outcome comprises information identifying a reel position of said gaming machine; and further comprising the step of using said outcome information to display said reel position on said remote terminal.

49. (Previously Presented) The method of claim 39 and further including the steps of receiving a player identifier; and transmitting said player identifier for identification of said player.

50. (Previously Presented) The method of claim 39 wherein said game outcome results from the server initiating game play on the selected gaming machine.

51. (Previously Presented) The method of claim 39 wherein said game outcome results from the manual game play on the selected gaming machine.

52. (Previously Presented) A remote computer for the remote play of a local gaming machine located within a gaming establishment and connected to a gaming server, the remote computer being located outside said gaming establishment, said remote computer connected to a gaming site through a global computing network served by said gaming server, said remote computer comprising:

a microprocessor;

memory connected to said microprocessor and including instructions for controlling said microprocessor; and

said microprocessor being operative with said instructions in said memory to:

receive information identifying a plurality of local gaming machines located within said gaming establishment from a gaming server;

transmit data selecting of at least one said plurality of local gaming machines for remote play;

receive a text or graphical outcome resulting from a local play of each said selected local gaming machine; and

generate a payout if said outcome meets predetermined criteria.

53. (Previously Presented) The remote computer of claim 52 wherein said selected gaming machine comprises a slot machine and wherein said outcome includes a reel position.
54. (Previously Presented) The remote computer of claim 52 wherein said operation of receiving information includes receiving information selecting at least two of said plurality of local gaming machines for remote play.
55. (Previously Presented) The remote computer of claim 52 wherein said operation of receiving information includes receiving a gaming machine identifier.
56. (Previously Presented) The remote computer of claim 52 wherein said operation of receiving information includes receiving a gaming machine type.
57. (Previously Presented) The remote computer of claim 52 wherein said operation of receiving information includes receiving player preferences.
58. (Previously Presented) The remote computer of claim 52 wherein said selected gaming machine comprises a video poker machine including a display for displaying a poker hand.
59. (Previously Presented) The remote computer of claim 52 wherein said outcome comprises data identifying the value of said payout; and further comprising the operation of using said payout data to simulate a display of said outcome at said remote location.
60. (Previously Presented) The remote computer of claim 52 wherein said outcome comprises information identifying a reel position of said selected gaming machine; and further comprising the operation of using said outcome data to display said reel position at said remote location.
61. (Previously Presented) The remote computer of claim 52 further including the operations of: receiving a player identifier; and transmitting said player identifier for identification of said player.

62. (Previously Presented) A remote computer located outside a gaming establishment, said gaming establishment having a plurality of gaming machines linked by a gaming server, said remote computer connected to a gaming site through a global computing network served by said gaming server comprising:

means for receiving information identifying a plurality of local gaming machines each engaged in play within said gaming establishment;

means for transmitting data from said remote computer for selecting at least one of said plurality of local gaming machines for information transfer;

means for receiving a text or graphical outcome resulting from a play of said selected local gaming machines; and

means for generating a payout if said outcome meets predetermined criteria.

Under the Paperwork Reduction Act of 1995, no persons are required to respond to a collection of information unless it displays a valid OMB control number.

PATENT APPLICATION FEE DETERMINATION RECORD Substitute for Form PTO-875					Application or Docket Number <b>09/688,501</b>						
CLAIMS AS FILED - PART I					SMALL ENTITY		OR		OTHER THAN SMALL ENTITY		
(Column 1)		(Column 2)									
FOR	NUMBER FILED	NUMBER EXTRA			RATE	FEE			RATE	FEE	
BASIC FEE (37 CFR 1.16(a))						\$				\$	
TOTAL CLAIMS (37 CFR 1.16(c))	39	minus 20 =	-		X \$	=			X \$	=	
INDEPENDENT CLAIMS (37 CFR 1.16(b))	8	minus 3 =	-		X \$	=			X \$	=	
MULTIPLE DEPENDENT CLAIM PRESENT (37 CFR 1.16(d))					+\$	=			+\$	=	
* If the difference in column 1 is less than zero, enter "0" in column 2.					TOTAL				TOTAL		
CLAIMS AS AMENDED - PART II					SMALL ENTITY		OR		OTHER THAN SMALL ENTITY		
(Column 1)		(Column 2)		(Column 3)							
AMENDMENT A	CLAIMS REMAINING AFTER AMENDMENT		HIGHEST NUMBER PREVIOUSLY PAID FOR	PRESENT EXTRA		RATE	ADDITIONAL FEE			RATE	ADDITIONAL FEE
	Total (37 CFR 1.16(c))	26	Minus	39	=	X \$	=			X \$	=
	Independent (37 CFR 1.16(b))	5	Minus	8	=	X \$	=			X \$	=
	FIRST PRESENTATION OF MULTIPLE DEPENDENT CLAIM (37 CFR 1.16(d))					+\$	=			+\$	=
					TOTAL ADD'L FEE				TOTAL ADD'L FEE		
AMENDMENT B	CLAIMS REMAINING AFTER AMENDMENT		HIGHEST NUMBER PREVIOUSLY PAID FOR	PRESENT EXTRA		RATE	ADDITIONAL FEE			RATE	ADDITIONAL FEE
	Total (37 CFR 1.16(c))		Minus	**	=	X \$	=			X \$	=
	Independent (37 CFR 1.16(b))		Minus	***	=	X \$	=			X \$	=
	FIRST PRESENTATION OF MULTIPLE DEPENDENT CLAIM (37 CFR 1.16(d))					+\$	=			+\$	=
					TOTAL ADD'L FEE				TOTAL ADD'L FEE		
AMENDMENT C	CLAIMS REMAINING AFTER AMENDMENT		HIGHEST NUMBER PREVIOUSLY PAID FOR	PRESENT EXTRA		RATE	ADDITIONAL FEE			RATE	ADDITIONAL FEE
	Total (37 CFR 1.16(c))		Minus	**	=	X \$	=			X \$	=
	Independent (37 CFR 1.16(b))		Minus	***	=	X \$	=			X \$	=
	FIRST PRESENTATION OF MULTIPLE DEPENDENT CLAIM (37 CFR 1.16(d))					+\$	=			+\$	=
					TOTAL ADD'L FEE				TOTAL ADD'L FEE		

\* If the entry in column 1 is less than the entry in column 2, write "0" in column 3.  
 \*\* If the "Highest Number Previously Paid For" IN THIS SPACE is less than 20, enter "20".  
 \*\*\* If the "Highest Number Previously Paid For" IN THIS SPACE is less than 3, enter "3".  
 The "Highest Number Previously Paid For" (Total or Independent) is the highest number found in the appropriate box in column 1.

This collection of information is required by 37 CFR 1.16. The information is required to obtain or retain a benefit by the public which is to file (and by the USPTO to process) an application. Confidentiality is governed by 35 U.S.C. 122 and 37 CFR 1.14. This collection is estimated to take 12 minutes to complete, including gathering, preparing, and submitting the completed application form to the USPTO. Time will vary depending upon the individual case. Any comments on the amount of time you require to complete this form and/or suggestions for reducing this burden, should be sent to the Chief Information Officer, U.S. Patent and Trademark Office, U.S. Department of Commerce, P.O. Box 1450, Alexandria, VA 22313-1450. DO NOT SEND FEES OR COMPLETED FORMS TO THIS ADDRESS. SEND TO: Commissioner for Patents, P.O. Box 1450, Alexandria, VA 22313-1450.

If you need assistance in completing the form, call 1-800-PTO-9199 and select option 2.



UNITED STATES PATENT AND TRADEMARK OFFICE

UNITED STATES DEPARTMENT OF COMMERCE  
United States Patent and Trademark Office  
Address: COMMISSIONER FOR PATENTS  
P.O. Box 1450  
Alexandria, Virginia 22313-1450  
www.uspto.gov

APPLICATION NO.	FILING DATE	FIRST NAMED INVENTOR	ATTORNEY DOCKET NO.	CONFIRMATION NO.
09/688,501	10/16/2000	Shridhar P. Joshi	47079-00077	3225
30223	7590	11/02/2005	EXAMINER	
JENKENS & GILCHRIST, P.C. 225 WEST WASHINGTON SUITE 2600 CHICAGO, IL 60606			RADA, ALEX P	
			ART UNIT	PAPER NUMBER
			3713	

DATE MAILED: 11/02/2005

Please find below and/or attached an Office communication concerning this application or proceeding.

Torkh

<b>Office Action Summary</b>	<b>Application No.</b> 09/688,501	<b>Applicant(s)</b> JOSHI, SHRIDHAR P.	
	<b>Examiner</b> Alex P. Rada	<b>Art Unit</b> 3713	

-- The MAILING DATE of this communication appears on the cover sheet with the correspondence address --  
**Period for Reply**

A SHORTENED STATUTORY PERIOD FOR REPLY IS SET TO EXPIRE 3 MONTH(S) OR THIRTY (30) DAYS, WHICHEVER IS LONGER, FROM THE MAILING DATE OF THIS COMMUNICATION.

- Extensions of time may be available under the provisions of 37 CFR 1.136(a). In no event, however, may a reply be timely filed after SIX (6) MONTHS from the mailing date of this communication.
- If NO period for reply is specified above, the maximum statutory period will apply and will expire SIX (6) MONTHS from the mailing date of this communication.
- Failure to reply within the set or extended period for reply will, by statute, cause the application to become ABANDONED (35 U.S.C. § 133). Any reply received by the Office later than three months after the mailing date of this communication, even if timely filed, may reduce any earned patent term adjustment. See 37 CFR 1.704(b).

**Status**

- 1)  Responsive to communication(s) filed on 25 July 2005.
- 2a)  This action is **FINAL**.
- 2b)  This action is non-final.
- 3)  Since this application is in condition for allowance except for formal matters, prosecution as to the merits is closed in accordance with the practice under *Ex parte Quayle*, 1935 C.D. 11, 453 O.G. 213.

**Disposition of Claims**

- 4)  Claim(s) 37-62 is/are pending in the application.
  - 4a) Of the above claim(s) \_\_\_\_\_ is/are withdrawn from consideration.
- 5)  Claim(s) \_\_\_\_\_ is/are allowed.
- 6)  Claim(s) 37-62 is/are rejected.
- 7)  Claim(s) \_\_\_\_\_ is/are objected to.
- 8)  Claim(s) \_\_\_\_\_ are subject to restriction and/or election requirement.

**Application Papers**

- 9)  The specification is objected to by the Examiner.
- 10)  The drawing(s) filed on \_\_\_\_\_ is/are: a)  accepted or b)  objected to by the Examiner.  
 Applicant may not request that any objection to the drawing(s) be held in abeyance. See 37 CFR 1.85(a).  
 Replacement drawing sheet(s) including the correction is required if the drawing(s) is objected to. See 37 CFR 1.121(d).
- 11)  The oath or declaration is objected to by the Examiner. Note the attached Office Action or form PTO-152.

**Priority under 35 U.S.C. § 119**

- 12)  Acknowledgment is made of a claim for foreign priority under 35 U.S.C. § 119(a)-(d) or (f).
    - a)  All   b)  Some \*   c)  None of:
    - 1.  Certified copies of the priority documents have been received.
    - 2.  Certified copies of the priority documents have been received in Application No. \_\_\_\_\_.
    - 3.  Copies of the certified copies of the priority documents have been received in this National Stage application from the International Bureau (PCT Rule 17.2(a)).
- \* See the attached detailed Office action for a list of the certified copies not received.

**Attachment(s)**

- 1)  Notice of References Cited (PTO-892)
- 4)  Interview Summary (PTO-413)  
Paper No(s)/Mail Date. \_\_\_\_\_
- 2)  Notice of Draftsperson's Patent Drawing Review (PTO-948)
- 5)  Notice of Informal Patent Application (PTO-152)
- 3)  Information Disclosure Statement(s) (PTO-1449 or PTO/SB/08)  
Paper No(s)/Mail Date \_\_\_\_\_
- 6)  Other: \_\_\_\_\_



### DETAILED ACTION

In response to the amendment filed July 25, 2005 in which the applicant had previously canceled claims 1-21, and 35-36, cancels claims 22-34, submits arguments and claims 37-62 are pending in this application.

#### *Claim Rejections - 35 USC § 103*

1. The following is a quotation of 35 U.S.C. 103(a) which forms the basis for all obviousness rejections set forth in this Office action:

(a) A patent may not be obtained though the invention is not identically disclosed or described as set forth in section 102 of this title, if the differences between the subject matter sought to be patented and the prior art are such that the subject matter as a whole would have been obvious at the time the invention was made to a person having ordinary skill in the art to which said subject matter pertains. Patentability shall not be negated by the manner in which the invention was made.

2. Claims 37-38 are rejected under 35 U.S.C. 103(a) as being unpatentable over Wiltshire et al. (US 6,409,602) in view of Paravia et al. (US 6,508,710).

3. Wiltshire et al discloses the following:

Accessing via a remote terminal (client/terminal), a gaming site (310 of figure 3) on a global computer network (column 8, lines 15-34) connected to the remote terminal (client/terminal), selecting a game of chance from a plurality of gaming machine located at a gaming establishment for remote play (figures 4b-9D), the remote terminal being located outside the gaming establishment, placing a wager for playing the selected game and receiving randomly-generated text or graphical outcome data at the remote terminal for the selected game the outcome data being generated by one of the plurality of gaming machines at the gaming establishment and relayed to the gaming site through a gaming server connected to the gaming site,

in which the examiner interprets the server/host containing the different programs and data of the different chance game to be a functional equivalent to placing a wager for playing the selected game and receiving randomly-generated text or graphical outcome data at the remote terminal for the selected game the outcome data being generated by one of the plurality of gaming machines at the gaming establishment and relayed to the gaming site through a gaming server connected to the gaming site (column 7, lines 7-56 and figures 2-3) as recited in claims 37-38.

Wiltshire et al does expressly disclose the following:

Providing via the remote terminal, personal identification information to the gaming site as recited in claims 37-38.

Paravia et al teaches the following:

Providing via the remote terminal, personal identification information to the gaming site (column 6, lines 49-55 and item 142 of figure 2) as recited in claims 37-38. By having providing personal identification information to the gaming site, one of ordinary skill in the art would provide a verification and permission to game players that are permitted to play.

Therefore, it would have been obvious to one of ordinary skill in the art at the time of the invention was made to modify Wiltshire et al to include personal identification information to the gaming site as taught Paravia et al to provide a verification and permission to game players that are permitted to play.

4. Claims 39-62 are rejected under 35 U.S.C. 103(a) as being unpatentable over Wiltshire et al. (US 6,409,602) in view of Walker et al. (US 6,001,016).
5. Wiltshire et al discloses the following:

Establishing a communication link between the remote terminal (client/terminal) and a gaming site (310 of figure 3) on a global computer network (column 8, lines 15-34), the gaming site in communication with a gaming server (server/host), selecting a gaming machine (figures 4B-9D) at the gaming establishment using the remote terminal, making a wager to play the selected gaming machine, receiving outcome data, including game outcome at the remote terminal resulting from a play of the gaming machine (figures 4B-9D), and generating a payout if the game outcome meets predetermined criteria (figure 4B, column 7, lines 7-56, and column 8, lines 15-34) as recited in claim 39.

The game outcome resulting from the server initiating game play on the selected gaming machine (column 8, lines 42-65) as recited in claim 50.

The remote computer having a microprocessor, memory connected to the microprocessor and including instructions for controlling the microprocessor, and the microprocessor being operative with the instructions in the memory to receive information identifying a plurality of local gaming machine located within the gaming establishment from a gaming server, receive a text or graphical outcome resulting from a local play of each of the selected gaming machines and generate payout if the outcome meets predetermined criteria (figures 4B-9D, column 6, line 44 – column 7, line 6, column 7, lines 7-56, and column 8, lines 15-34) as recited in claim 52.

The gaming server having means for receiving information identifying a plurality of gaming machines (figures 4B-9D) each engaged in play within the gaming establishment, means for receiving a text or graphical outcome resulting from a play of the selected gaming machines and means for generating a payout if the outcome

meets predetermined criteria (figures 4B-9D, column 6, line 44 – column 7, line 6, column 7, lines 7-56, and column 8, lines 15-34) as recited in claim 62.

Wiltshire et al does not expressly disclose the following:

The gaming server collecting outcome data from the gamine machines located inside the gaming establishment as recited in claims 39, 52 and 62.

The outcome data having information identifying the value of the payout and simulate a display of the game outcome at the remote location as recited in claims 40 and 59.

The outcome data to simulate a display of the game outcome on the remote terminal as recited in claim 41.

The selected gaming machine is a slot machine wherein the outcome data includes reel position as recited in claims 42, 48, 53, and 60.

The selected gaming machine is a video poker machine including a display for displaying a poker hand as recited in claims 43 and 58.

The receiving outcome data includes receiving outcome data from a plurality of gaming machine form remote play as recited in claim 44.

The outcome data includes a gaming machine identifier and gaming machine type as recited in claim 45-46 and 55-56.

The outcome data including receiving player preferences as recited in claims 47 and 57.

A player identifier and transmitting the player identifier for identification of the player as recited in claims 49 and 61.

Walker et al teaches the following:

The gaming server collecting outcome data from the gaming machines located inside the gaming establishment (figure 1) as recited in claims 39, 52 and 62.

The outcome data having information identifying the value of the payout and simulate a display of the game outcome at the remote location (column 5, lines 33-37) as recited in claims 40 and 59.

The outcome data to simulate a display of the game outcome on the remote terminal (column 5, lines 33-37) as recited in claim 41.

The selected gaming machine is a slot machine wherein the outcome data includes reel position (column 5, lines 33-37) as recited in claims 42, 48, 53-54, and 60.

The selected gaming machine is a video poker machine including a display for displaying a poker hand (column 5, lines 33-37) as recited in claims 43 and 58.

The receiving outcome data includes receiving outcome data from a plurality of gaming machine form remote play (column 6, lines 45-56) as recited in claim 44.

The outcome data includes a gaming machine identifier and gaming machine type (figure 5 and column 6, lines 31-44) as recited in claim 45-46 and 55-56.

The outcome data including receiving player preferences (column 6, lines 8-30) as recited in claims 47 and 57.

A player identifier and transmitting the player identifier for identification of the player (column 6, lines 8-30) as recited in claims 49 and 61.

The outcome results from the manual game play on the selected gaming machine (summary) as recited in claim 51. By transmitting data from the gaming machine located in the gaming establishment, one of ordinary skill in the art would

provide a system that does not require human intervention and live video transmission of the game being played.

Therefore, it would have been obvious to one of ordinary skill in the art at the time of the invention was made to modify Wiltshire et al to include the gaming server collecting outcome data from the game machines located inside the gaming establishment, the outcome data having information identifying the value of the payout and simulate a display of the game outcome at the remote location, the outcome data to simulate a display of the game outcome on the remote terminal, the selected gaming machine is a slot machine wherein the outcome data includes reel position, the selected gaming machine is a video poker machine including a display for displaying a poker hand, the receiving outcome data includes receiving outcome data from a plurality of gaming machine form remote play, the outcome data includes a gaming machine identifier and gaming machine type, the outcome data including receiving player preferences, and a player identifier and transmitting the player identifier for identification of the player as taught by Walker et al to provide a system that does not require human intervention and live video transmission of the game being played.

### ***Response to Arguments***

6. Applicant's arguments filed July 25, 2005 have been fully considered but they are not persuasive.

Applicant contends that the Wiltshire reference lacks a gaming site and the "access website" in figure 3 is merely a software download site for downloading the installation software. Once the

Art Unit: 3713

software is installed, the website 310 contribute nothing else to Wiltshire (i.e., provides no gaming data or information to the client/terminal). The Wiltshire reference does not disclose the user of two separate intermediate nodes – a gaming server and a gaming site – between the gaming machines and the remote gaming terminal. The outcome data from the gaming machine passes through two separate intermediate nodes noted before arriving at the gaming terminal.

In response the Wiltshire reference does disclose a gaming site (website) in figure 3, item 310. Wiltshire discloses in col. 8, lines 15-34 that a user accesses a website (gaming site) using a web browser such as Internet Explorer, Netscape Navigator or the like and downloads the program from the website (gaming site). The gaming data or information to the client/terminal is executed from the server/host computer, which updates the state (randomly-generated or graphical outcome data) of the game accordingly (col. 7, lines 7-44 and figure 2).

In response to applicant's argument that the references fail to show certain features of applicant's invention, it is noted that the features upon which applicant relies (i.e., two separate intermediate nodes, a real gaming machine) are not recited in the rejected claim(s). Although the claims are interpreted in light of the specification, limitations from the specification are not read into the claims. See *In re Van Geuns*, 988 F.2d 1181, 26 USPQ2d 1057 (Fed. Cir. 1993). The Wiltshire reference does disclose data passing through two separate intermediate nodes. Figure 1A discloses a first node being the network interface (115), which may access the Internet or a particular website on the Internet and the second node is the server/host (110).

Applicant contends that the host/server computer executing casino game programs is not a functionally equivalent to the gaming machines in a gaming establishment. Any evidence from Wiltshire or any other art recognizes a virtual gaming machine to be functionally equivalent to a gaming machine in a gaming establishment.

In response to applicant's arguments that the host/server computer executing casino game programs is not a functional equivalent to a gaming machine in a gaming establishment, it is noted that a gaming machine at a gaming establishment is just a computer that runs a program either on the gaming machine or communication to a server like in Walker (6,001,016), Karmarkar (6,508,709), and Paravia (6,508,710) to name a few. Since a physical embodiment of various games have been re-implement into microcomputer-based video gaming stations for the last 20 years (Wiltshire-background), it is obvious to a person of ordinary skill in the art would recognize that gaming machine can be re-implemented into a video gaming system, which is nothing more than a cabinet having a monitor, a program either on the gaming machine or communication to a server, and some means of accepting and dispensing wagers. When a gaming machine calculates the game results on the gaming machine at a gaming site, the functional equivalent to that would be a gaming machine running a program and the calculations are carried out on a sever located at a gaming a site and routed back to the gaming machine at the gaming site. The only difference is the gaming results are calculated on the server and communicated back to the gaming machine instead of calculating the gaming results at the gaming machine itself. If you take the same computer based video gaming machine and place that video game program on a home PC, the only things that have changed are how the program (results and calculations) are being communicated and how wagers are accepted and payouts awarded. Therefore, a host/server computer executing a casino game program is functionally equivalent to a gaming machine in a gaming establishment.

***Conclusion***

7. **THIS ACTION IS MADE FINAL.** Applicant is reminded of the extension of time policy as set forth in 37 CFR 1.136(a).



A shortened statutory period for reply to this final action is set to expire THREE MONTHS from the mailing date of this action. In the event a first reply is filed within TWO MONTHS of the mailing date of this final action and the advisory action is not mailed until after the end of the THREE-MONTH shortened statutory period, then the shortened statutory period will expire on the date the advisory action is mailed, and any extension fee pursuant to 37 CFR 1.136(a) will be calculated from the mailing date of the advisory action. In no event, however, will the statutory period for reply expire later than SIX MONTHS from the mailing date of this final action.

Any inquiry concerning this communication or earlier communications from the examiner should be directed to Alex P. Rada whose telephone number is 571-272-4452. The examiner can normally be reached on Monday - Friday, 08:00-16:00.

If attempts to reach the examiner by telephone are unsuccessful, the examiner's supervisor, Xuan Thai can be reached on 571-272-7147. The fax phone number for the organization where this application or proceeding is assigned is 571-273-8300.

Information regarding the status of an application may be obtained from the Patent Application Information Retrieval (PAIR) system. Status information for published applications may be obtained from either Private PAIR or Public PAIR. Status information for unpublished applications is available through Private PAIR only. For more information about the PAIR system, see <http://pair-direct.uspto.gov>. Should you have questions on access to the Private PAIR system, contact the Electronic Business Center (EBC) at 866-217-9197 (toll-free).

  
APR

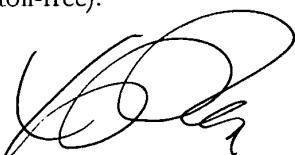
  
XUAN M. THAI  
SUPERVISORY PATENT EXAMINER  
TC3700

<b>Notice of References Cited</b>	Application/Control No. 09/688,501	Applicant(s)/Patent Under Reexamination JOSHI, SHRIDHAR P.	
	Examiner Alex P. Rada	Art Unit 3713	Page 1 of 1

**U.S. PATENT DOCUMENTS**

*	Document Number Country Code-Number-Kind Code	Date MM-YYYY	Name	Classification
A	US-6,409,602	06-2002	Wiltshire et al.	463/42
B	US-6,508,710	01-2003	Paravia et al.	463/42
C	US-6,001,016	12-1999	Walker et al.	463/42
D	US-6,508,709	01-2003	Karmarkar, Jayant S.	463/42
E	US-			
F	US-			
G	US-			
H	US-			
I	US-			
J	US-			
K	US-			
L	US-			
M	US-			

**FOREIGN PATENT DOCUMENTS**

*	Document Number Country Code-Number-Kind Code	Date MM-YYYY	Country	Name	Classification
N					
O					
P					
Q					
R					
S					
T					

**NON-PATENT DOCUMENTS**

*	Include as applicable: Author, Title Date, Publisher, Edition or Volume, Pertinent Pages)
U	
V	
W	
X	

\*A copy of this reference is not being furnished with this Office action. (See MPEP § 707.05(a).)  
Dates in MM-YYYY format are publication dates. Classifications may be US or foreign.

**Index of Claims**



Application/Control No.

09/688,501

Examiner

Alex P. Rada

Applicant(s)/Patent under Reexamination

JOSHI, SHRIDHAR P.

Art Unit

3713

√	Rejected
=	Allowed

-	(Through numeral) Cancelled
+	Restricted

N	Non-Elected
I	Interference

A	Appeal
O	Objected

Claim		Date			
Final	Original	10/19/05			
1					
2					
3					
4					
5					
6					
7					
8					
9					
10					
11					
12					
13					
14					
15					
16					
17					
18					
19					
20					
21					
22					
23					
24					
25					
26					
27					
28					
29					
30					
31					
32					
33					
34					
35					
36					
37	√				
38	√				
39	√				
40	√				
41	√				
42	√				
43	√				
44	√				
45	√				
46	√				
47	√				
48	√				
49	√				
50	√				

Claim		Date			
Final	Original	10/19/05			
51	√				
52	√				
53	√				
54	√				
55	√				
56	√				
57	√				
58	√				
59	√				
60	√				
61	√				
62	√				
63					
64					
65					
66					
67					
68					
69					
70					
71					
72					
73					
74					
75					
76					
77					
78					
79					
80					
81					
82					
83					
84					
85					
86					
87					
88					
89					
90					
91					
92					
93					
94					
95					
96					
97					
98					
99					
100					

Claim		Date			
Final	Original				
101					
102					
103					
104					
105					
106					
107					
108					
109					
110					
111					
112					
113					
114					
115					
116					
117					
118					
119					
120					
121					
122					
123					
124					
125					
126					
127					
128					
129					
130					
131					
132					
133					
134					
135					
136					
137					
138					
139					
140					
141					
142					
143					
144					
145					
146					
147					
148					
149					
150					

**Search Notes**



Application/Control No.

09/688,501

Examiner

Alex P. Rada

Applicant(s)/Patent under  
Reexamination

JOSHI, SHRIDHAR P.

Art Unit

3713

**SEARCHED**

Class	Subclass	Date	Examiner
463	16-25 29,40-42	6/24/2004	APR
Search	Updated	4/13/2005	APR
Above	Updated	10/19/2005	APR

**SEARCH NOTES  
(INCLUDING SEARCH STRATEGY)**

	DATE	EXMR

**INTERFERENCE SEARCHED**

Class	Subclass	Date	Examiner



PTO/SB/92 (09-04)  
Approved for use through 07/31/2006. OMB 0651-0031  
U.S. Patent and Trademark Office; U.S. DEPARTMENT OF COMMERCE

Under the Paperwork Reduction Act of 1995, no persons are required to respond to a collection of information unless it displays a valid OMB control number.

Application No. (if known): 09/688501

Attorney Docket No.: 47079-00077USPT

### Certificate of Mailing under 37 CFR 1.8

I hereby certify that this correspondence is being deposited with the United States Postal Service with sufficient postage as first class mail in an envelope addressed to:

MS AF  
Commissioner for Patents  
P.O. Box 1450  
Alexandria, VA 22313-1450

on December 30, 2005  
Date

Signature

Daniel G. Nguyen

Typed or printed name of person signing Certificate

42,933

Registration Number, if applicable

(713) 951-3300

Telephone Number

Note: Each paper must have its own certificate of mailing, or this certificate must identify each submitted paper.

Amendment After Final Action (37 C.F.R. Section 1.116) (10 pages)  
Amendment Transmittal (1 page)  
Postcard

CHICAGO 322022V1 47079-00077



AF-13714  
Zjed

<b>AMENDMENT TRANSMITTAL LETTER</b>			Docket No. 47079-00077USPT		
Application No. 09/688501	Filing Date October 16, 2000	Examiner A. P. Rada	Art Unit 3714		
Applicant(s): Bradley A. Rose					
Invention: METHOD OF TRANSFERRING GAMING DATA ON A GLOBAL COMPUTER NETWORK					
<b>TO THE COMMISSIONER FOR PATENTS</b>					
Transmitted herewith is an amendment in the above-identified application. The fee has been calculated and is transmitted as shown below.					
<b>CLAIMS AS AMENDED</b>					
	Claims Remaining After Amendment	Highest Number Previously Paid	Number Extra Claims Present	Rate	
<b>Total Claims</b>	62	- 62 =		x	
<b>Independent Claims</b>	4	- 7 =		x	
Multiple Dependent Claims (check if applicable) <input type="checkbox"/>					
Other fee (please specify):					
<b>TOTAL ADDITIONAL FEE FOR THIS AMENDMENT:</b>					0.00
<input checked="" type="checkbox"/> Large Entity <span style="margin-left: 200px;"><input type="checkbox"/> Small Entity</span>					
<input checked="" type="checkbox"/> No additional fee is required for this amendment.					
<input type="checkbox"/> Please charge Deposit Account No. _____ in the amount of \$ _____ . A duplicate copy of this sheet is enclosed.					
<input type="checkbox"/> A check in the amount of \$ _____ to cover the filing fee is enclosed.					
<input type="checkbox"/> Payment by credit card. Form PTO-2038 is attached.					
<input checked="" type="checkbox"/> The Director is hereby authorized to charge and credit Deposit Account No. <u>10-0447</u> as described below. A duplicate copy of this sheet is enclosed. (47079-00077-D.Nguyen)					
<input checked="" type="checkbox"/> Credit any overpayment.					
<input checked="" type="checkbox"/> Charge any additional filing or application processing fees required under 37 CFR 1.16 and 1.17.					
 Daniel G. Nguyen Attorney Reg. No.: 42,933			Dated: <u>December 30, 2005</u>		
JENKENS & GILCHRIST, A PROFESSIONAL CORPORATION 225 W. Washington, Ste. 2600 Chicago, Illinois 60606-3418 (312) 425-8513					



Docket No.: 47079-00077USPT  
(PATENT)

**IN THE UNITED STATES PATENT AND TRADEMARK OFFICE**

---

In re Patent Application of:  
Shridhar P. Joshi

Confirmation No: 3225

Application No.: 09/688501

Art Unit: 3714

Filed: October 16, 2000

Examiner: Alex P. Rada

For: METHOD OF TRANSFERRING GAMING  
DATA ON A GLOBAL COMPUTER  
NETWORK

---

**RESPONSE TO FINAL OFFICE ACTION**

MS AF  
Commissioner for Patents  
P.O. Box 1450  
Alexandria, VA 22313-1450

Dear Sir:

**INTRODUCTORY COMMENTS**

Responsive to the Final Office Action mailed November 2, 2005, reconsideration and allowance of the present application is respectfully requested in view of the following remarks.

**Amendments to the Claims** are reflected in the listing of claims that begins on page 2 of this paper.

**Remarks/Arguments** begin on page 2 of this paper.

CHICAGO 321887v2 47079-00077



Under the Paperwork Reduction Act of 1995, no persons are required to respond to a collection of information unless it displays a valid OMB control number.

Application No. (if known): 09/688501

Attorney Docket No.: 47079-00077USPT

### Certificate of Mailing under 37 CFR 1.8

I hereby certify that this correspondence is being deposited with the United States Postal Service with sufficient postage as first class mail in an envelope addressed to:

MS AF  
Commissioner for Patents  
P.O. Box 1450  
Alexandria, VA 22313-1450

on December 30, 2005  
Date

*Daniel Nguyen*  
Signature

Daniel G. Nguyen  
Typed or printed name of person signing Certificate

42,933  
Registration Number, if applicable

(713) 951-3300  
Telephone Number

Note: Each paper must have its own certificate of mailing, or this certificate must identify each submitted paper.

Amendment After Final Action (37 C.F.R. Section 1.116) (10 pages)  
Amendment Transmittal (1 page)  
Postcard





AF-13714  
Zjed

<b>AMENDMENT TRANSMITTAL LETTER</b>			Docket No. 47079-00077USPT		
Application No. 09/688501	Filing Date October 16, 2000	Examiner A. P. Rada	Art Unit 3714		
Applicant(s): Bradley A. Rose					
Invention: METHOD OF TRANSFERRING GAMING DATA ON A GLOBAL COMPUTER NETWORK					
<b>TO THE COMMISSIONER FOR PATENTS</b>					
Transmitted herewith is an amendment in the above-identified application. The fee has been calculated and is transmitted as shown below.					
<b>CLAIMS AS AMENDED</b>					
	Claims Remaining After Amendment	Highest Number Previously Paid	Number Extra Claims Present	Rate	
<b>Total Claims</b>	62	- 62 =		x	
<b>Independent Claims</b>	4	- 7 =		x	
Multiple Dependent Claims (check if applicable) <input type="checkbox"/>					
Other fee (please specify):					
<b>TOTAL ADDITIONAL FEE FOR THIS AMENDMENT:</b>					0.00
<input checked="" type="checkbox"/> Large Entity <span style="margin-left: 200px;"><input type="checkbox"/> Small Entity</span>					
<input checked="" type="checkbox"/> No additional fee is required for this amendment.					
<input type="checkbox"/> Please charge Deposit Account No. _____ in the amount of \$ _____ A duplicate copy of this sheet is enclosed.					
<input type="checkbox"/> A check in the amount of \$ _____ to cover the filing fee is enclosed.					
<input type="checkbox"/> Payment by credit card. Form PTO-2038 is attached.					
<input checked="" type="checkbox"/> The Director is hereby authorized to charge and credit Deposit Account No. <u>10-0447</u> as described below. A duplicate copy of this sheet is enclosed. (47079-00077-D.Nguyen)					
<input checked="" type="checkbox"/> Credit any overpayment.					
<input checked="" type="checkbox"/> Charge any additional filing or application processing fees required under 37 CFR 1.16 and 1.17.					
Daniel G. Nguyen Attorney Reg. No.: 42,933			Dated: <u>December 30, 2005</u>		
JENKENS & GILCHRIST, A PROFESSIONAL CORPORATION 225 W. Washington, Ste. 2600 Chicago, Illinois 60606-3418 (312) 425-8513					



Docket No.: 47079-00077USPT  
(PATENT)

**IN THE UNITED STATES PATENT AND TRADEMARK OFFICE**

---

In re Patent Application of:  
Shridhar P. Joshi

Confirmation No: 3225

Application No.: 09/688501

Art Unit: 3714

Filed: October 16, 2000

Examiner: Alex P. Rada

For: METHOD OF TRANSFERRING GAMING  
DATA ON A GLOBAL COMPUTER  
NETWORK

---

**RESPONSE TO FINAL OFFICE ACTION**

MS AF  
Commissioner for Patents  
P.O. Box 1450  
Alexandria, VA 22313-1450

Dear Sir:

**INTRODUCTORY COMMENTS**

Responsive to the Final Office Action mailed November 2, 2005, reconsideration and allowance of the present application is respectfully requested in view of the following remarks.

**Amendments to the Claims** are reflected in the listing of claims that begins on page 2 of this paper.

**Remarks/Arguments** begin on page 2 of this paper.

CHICAGO 321887v2 47079-00077

**REMARKS**

Claims 37-62 were pending in this application. No claims were added, amended, or cancelled. Hence, claims 37-62 remain pending in this application.

No new matter was added.

**Claim Rejections Under 35 U.S.C. § 103(a)**

Independent claims 37-38 were rejected under 35 U.S.C. § 103(a) as being unpatentable over the combination of U.S. Patent Nos. 6,409,602 to Wiltshire et al. (“Wiltshire”) and 6,580,710 to Paravia et al. (“Paravia”). The Examiner states that Wiltshire discloses each element of these claims except for the provision of personal identification information to the gaming sites via the remote terminal. The Examiner contends, however, that Paravia teaches this aspect of the invention, and that it would have been obvious to combine Wiltshire and Paravia to arrive at the claimed invention.

Claims 39-62 were rejected under 35 U.S.C. § 103(a) as being unpatentable over the combination of Wiltshire and U.S. Patent No. 6,001,016 to Walker (“Walker”). With respect to independent claims 39, 52, and 62, the Examiner states that Wiltshire discloses each element of these claims except for the collection of outcome data from the gaming machines located in the gaming establishment. The Examiner contends, nevertheless, that Walker teaches this aspect of the invention, and that it would have been obvious to combine Wiltshire and Walker to arrive at the claimed invention.

Applicant respectfully traverses these rejections on the basis that, even if there is motivation to combine the above references (which there is not), significant claim features and limitations are still missing from the proposed combinations.

**Arguments in Support of the Claims**

Applicant’s invention, as recited in amended independent claims 37-39, 52, and 62, is directed to a remote gaming method, and a computer therefor, where players at gaming terminals located outside a gaming establishment may play gaming machines located inside the gaming establishment. Outcome data is randomly generated by each gaming machine of the “plurality

of gaming machines”. In this regard, the remote gaming method (and computer therefor) of the claimed invention may be considered to be decentralized.

Wiltshire’s video gaming system, on the other hand, is centralized. In Wiltshire, a central server/host computer executing a gaming program provides all the wagering game content to a plurality of client/terminal computers. *See, e.g., col. 2, lines 35-44.* Nowhere does Wiltshire (or any other art of record) disclose or suggest a remote gaming method (or computer therefor) involving a plurality of gaming machines, as recited in the claimed invention.

Because of the defects in Wiltshire, the Examiner has resorted to the concept of a **functional equivalent** to reject the claims. In a previous communication, Applicant explained that a functional equivalent must be recognized in the prior art. This recognition must **NOT** be the Examiner’s own recognition, but must instead be found in the prior art. *See MPEP 2144.06.* In other words, Wiltshire or another prior art reference of record must state that a centralized video gaming system (i.e., a system where all the gaming content are provided by a single computer) is functionally equivalent to a decentralized gaming system (i.e., a system where each gaming machine provides its own gaming content).

The Examiner has responded by referring to statement from Wiltshire’s background: “Since a physical embodiment of various games have been re-implement (sic) into microcomputer-based video gaming stations for the last 20 years (Wiltshire-background), it is obvious to a person of ordinary skill in the art would (sic) recognize that gaming machine can be re-implemented into a video gaming system, ...” *Office Action, page 9, lines 5-8.*

Exactly how the above statement supports the Examiner’s functional equivalency position is unclear to Applicant. The use of the term “microcomputer-based” to differentiate the games from the past necessarily means that those games are **NOT** microcomputer-based (i.e., those games used real dice, cards, wheels, etc.). However, Applicant’s gaming machines **ARE** microcomputer-based. Therefore, to the extent the Examiner compares Applicant’s gaming machines to non-microcomputer-based games from the past, the comparison is flawed. Accordingly, Applicant respectfully submits that the Examiner has still failed to meet the standard for raising a functionally equivalent rejection.

As demonstrated above, Wiltshire’s comment regarding the games from the past has, at best, a neutral effect on Applicant’s remote gaming method (and computer therefor).

Wiltshire's other comments, however, clearly distinguish a centralized video gaming system from Applicant's decentralized gaming method (and computer therefor):

However, in all of these non-website-based systems the gaming program is executed in whole or in part on the individual gaming station. As a result, each gaming station becomes expensive to manufacture. Because the physical structure of the gaming station is designed to accommodate a particular game, multiple gaming stations require additional hardware and, therefore, further increase the cost of a cluster of these stations.

In addition, since the games are executed on individual gaming stations, modifications and upgrades to the gaming programs require access to the individual gaming stations, which renders the gaming stations inaccessible to the patron during the modification and/or upgrade process.

*Wiltshire, col. 2, lines 6-18.*

As can be seen, Wiltshire plainly teaches that a centralized video gaming system is far superior to gaming systems in which the gaming program is executed on the individual gaming station, as in the case of Applicant's gaming method (and computer therefor). Having clearly taught away from decentralized gaming systems, Applicant respectfully submits that Wiltshire cannot now be used to support a completely contrary position, as urged by the Examiner.

Moreover, there are significant advantages to Applicant's gaming method (and computer therefor) that are not available in Wiltshire (or any other art of record). For example, players who favor a specific gaming machine at the gaming establishment would be able to select/play that very same gaming machine (i.e., same floor location, same bank, same cabinet, same processor, etc.) from their home. *See, e.g., claim 39.* Thus, consider a person from Southern California who has just returned from a Las Vegas gaming establishment where he/she especially enjoyed playing one particular gaming machine from amongst a plurality gaming machines. With the claimed gaming method (and computer therefor), the person can go online and select/play the very same gaming machine he/she enjoyed playing in the Las Vegas gaming establishment.

In addition, as the Examiner is no doubt aware, many players of wagering games believe strongly in luck and are often sentimental or superstitious about a certain gaming machine. Oftentimes, these players will return to the same physical gaming machine, believing that doing so will bring them luck. Moreover, players frequently trade stories and rumors with each other about certain gaming machines that have performed particularly well (or not so well). With applicant's gaming method (and computer therefor), these players have the option of going

Application No.: 09/688501

Docket No.: 47079-00077USPT

home and remotely selecting/playing the very same gaming machine that is the object of the sentiments, superstitions, or rumors. Such an option is not available with the centralized gaming system of Wiltshire.

Accordingly, based on the foregoing, even if there is motivation to combine Wiltshire with Paravia and/or Walker in the manner urged by the Examiner, the resulting combination would still not produce the claimed invention. Therefore, withdrawal of the rejections against independent claims 37-39, 52, and 62 is respectfully requested.

As for dependent claims 40-51 and 53-61, although they may recite independently allowable subject matter, these claims depend from the independent claims and are therefore allowable for at least the same reasons. Accordingly, withdrawal of the rejections against the dependent claims is also respectfully requested.

#### CONCLUSION

In view of the above, Applicant believes each of the presently pending claims in this application is believed to be in immediate condition for allowance.

Dated December 30, 2005

Respectfully submitted,

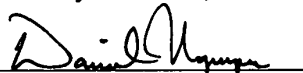
By   
Daniel G. Nguyen

Registration No.: 42,933  
JENKENS & GILCHRIST, A PROFESSIONAL  
CORPORATION  
225 W. Washington, Ste. 2600  
Chicago, Illinois 60606-3418  
(713) 951-3354  
(713) 951-3314 Facsimile  
Attorneys For Applicant

**APPENDIX**

Claims 1-36. (Cancelled)

37. (Previously Presented) A remote gaming method comprising:  
accessing, via a remote terminal, a gaming site on a global computer network connected to said remote terminal;  
providing, via said remote terminal, personal identification information to said gaming site;  
selecting, via said remote terminal, a game of chance from a plurality of gaming machines located at a gaming establishment for remote play, said remote terminal being located outside said gaming establishment;  
placing, via said remote terminal, a wager for playing said selected game; and  
receiving randomly-generated text or graphical outcome data at said remote terminal for said selected game, said outcome data being generated by one of said plurality of gaming machines at said gaming establishment and relayed to said gaming site through a gaming server connected to said gaming site.
38. (Previously Presented) A remote gaming method using a gaming server, a remote terminal, and a gaming site on a global computer network, said gaming server being located at a gaming establishment, said remote terminal being located outside said gaming establishment, said gaming site being provided on said global computer network, the method comprising:  
receiving, at said gaming server, personal identification information, game selection information, and wager information from a player accessing said gaming site via said remote terminal, said remote terminal being connected to said global computer network;  
randomly generating outcome data at one of a plurality of gaming machines communicatively coupled to said gaming server, said outcome data being generated for a game selected according to said game selection information, said plurality of gaming machines being located at said gaming establishment;  
receiving said outcome data at said gaming server; and  
transmitting said outcome data from said gaming server to said gaming site for display to said player on said remote terminal in text or graphical form.

39. (Previously Presented) A method for playing a gaming machine located inside a gaming establishment from a remote terminal located outside the gaming establishment comprising:

establishing a communication link between said remote terminal and a gaming site on a global computer network, said gaming site in communication with a gaming server for collecting outcome data from gaming machines located inside the gaming establishment;

selecting a gaming machine at said gaming establishment using said remote terminal;

making a wager to play the selected gaming machine;

receiving outcome data, including game outcome, at said remote terminal resulting from a play of said gaming machine; and

generating a payout if said game outcome meets predetermined criteria.

40. (Previously Presented) The method of claim 39 wherein said outcome data comprises information identifying the value of said payout; and further comprising the step of using said payout information to simulate a display of said game outcome at said remote location.

41. (Previously Presented) The method of claim 39 further comprising using said outcome data to simulate a display of said game outcome on said remote terminal.

42. (Previously Presented) The method of claim 39, wherein said selected gaming machine comprises a slot machine and wherein said game outcome data includes a reel position.

43. (Previously Presented) The method of claim 39 wherein said selected gaming machine comprises a video poker machine including a display for displaying a poker hand.

44. (Previously Presented) The method of claim 39 wherein said step of receiving outcome data includes receiving outcome data from a plurality of gaming machines for remote play.

45. (Previously Presented) The method of claim 44 wherein said step of receiving outcome data includes receiving a gaming machine identifier.

46. (Previously Presented) The method of claim 44 wherein said step of receiving outcome data includes receiving a gaming machine type.

47. (Previously Presented) The method of claim 44 wherein said step of receiving outcome data includes receiving player preferences.



48. (Previously Presented) The method of claim 39 wherein said selected gaming machine comprises a slot machine and wherein said game outcome comprises information identifying a reel position of said gaming machine; and further comprising the step of using said outcome information to display said reel position on said remote terminal.

49. (Previously Presented) The method of claim 39 and further including the steps of receiving a player identifier; and transmitting said player identifier for identification of said player.

50. (Previously Presented) The method of claim 39 wherein said game outcome results from the server initiating game play on the selected gaming machine.

51. (Previously Presented) The method of claim 39 wherein said game outcome results from the manual game play on the selected gaming machine.

52. (Previously Presented) A remote computer for the remote play of a local gaming machine located within a gaming establishment and connected to a gaming server, the remote computer being located outside said gaming establishment, said remote computer connected to a gaming site through a global computing network served by said gaming server, said remote computer comprising:

- a microprocessor;
- memory connected to said microprocessor and including instructions for controlling said microprocessor; and
- said microprocessor being operative with said instructions in said memory to:
  - receive information identifying a plurality of local gaming machines located within said gaming establishment from a gaming server;
  - transmit data selecting of at least one said plurality of local gaming machines for remote play;
  - receive a text or graphical outcome resulting from a local play of each said selected local gaming machine; and
  - generate a payout if said outcome meets predetermined criteria.

53. (Previously Presented) The remote computer of claim 52 wherein said selected gaming machine comprises a slot machine and wherein said outcome includes a reel position.

54. (Previously Presented) The remote computer of claim 52 wherein said operation of receiving information includes receiving information selecting at least two of said plurality of local gaming machines for remote play.

55. (Previously Presented) The remote computer of claim 52 wherein said operation of receiving information includes receiving a gaming machine identifier.

56. (Previously Presented) The remote computer of claim 52 wherein said operation of receiving information includes receiving a gaming machine type.

57. (Previously Presented) The remote computer of claim 52 wherein said operation of receiving information includes receiving player preferences.

58. (Previously Presented) The remote computer of claim 52 wherein said selected gaming machine comprises a video poker machine including a display for displaying a poker hand.

59. (Previously Presented) The remote computer of claim 52 wherein said outcome comprises data identifying the value of said payout; and further comprising the operation of using said payout data to simulate a display of said outcome at said remote location.

60. (Previously Presented) The remote computer of claim 52 wherein said outcome comprises information identifying a reel position of said selected gaming machine; and further comprising the operation of using said outcome data to display said reel position at said remote location.

61. (Previously Presented) The remote computer of claim 52 further including the operations of: receiving a player identifier; and transmitting said player identifier for identification of said player.

62. (Previously Presented) A remote computer located outside a gaming establishment, said gaming establishment having a plurality of gaming machines linked by a gaming server, said remote computer connected to a gaming site through a global computing network served by said gaming server comprising:

means for receiving information identifying a plurality of local gaming machines each engaged in play within said gaming establishment;

means for transmitting data from said remote computer for selecting at least one of said plurality of local gaming machines for information transfer;

means for receiving a text or graphical outcome resulting from a play of said selected local gaming machines; and

for generating a payout if said outcome meets predetermined criteria.

Under the Paperwork Reduction Act of 1995, no persons are required to respond to a collection of information unless it displays a valid OMB control number.

PATENT APPLICATION FEE DETERMINATION RECORD					Application #/ Docket Number <b>09/688,501</b>					
CLAIMS AS FILED - PART I					SMALL ENTITY		OR		OTHER THAN SMALL ENTITY	
FOR	NUMBER FILED	NUMBER EXTRA			RATE	FEE		RATE	FEE	
BASIC FEE (37 CFR 1.16(d))						\$			\$	
TOTAL CLAIMS (37 CFR 1.16(c))						X \$		X \$		
INDEPENDENT CLAIMS (37 CFR 1.16(b))						X \$		X \$		
MULTIPLE DEPENDENT CLAIM PRESENT (37 CFR 1.16(d))						+ \$		+ \$		
* If the difference in column 1 is less than zero, enter "0" in column 2.					TOTAL			TOTAL		
CLAIMS AS AMENDED - PART II					SMALL ENTITY		OR		OTHER THAN SMALL ENTITY	
AMENDMENT A	CLAIMS REMAINING AFTER AMENDMENT	HIGHEST NUMBER PREVIOUSLY PAID FOR	PRESENT EXTRA		RATE	ADDITIONAL FEE		RATE	ADDITIONAL FEE	
	Total (37 CFR 1.16(d))	Minus	**		X \$			X \$		
	Independent (37 CFR 1.16(b))	Minus	***		X \$			X \$		
	FIRST PRESENTATION OF MULTIPLE DEPENDENT CLAIM (37 CFR 1.16(d))					+ \$			+ \$	
* If the entry in column 1 is less than the entry in column 2, write "0" in column 3.					TOTAL ADD'L FEE			TOTAL ADD'L FEE		
AMENDMENT B	CLAIMS REMAINING AFTER AMENDMENT	HIGHEST NUMBER PREVIOUSLY PAID FOR	PRESENT EXTRA		RATE	ADDITIONAL FEE		RATE	ADDITIONAL FEE	
	Total (37 CFR 1.16(d))	Minus	**		X \$			X \$		
	Independent (37 CFR 1.16(b))	Minus	***		X \$			X \$		
	FIRST PRESENTATION OF MULTIPLE DEPENDENT CLAIM (37 CFR 1.16(d))					+ \$			+ \$	
* If the entry in column 1 is less than the entry in column 2, write "0" in column 3.					TOTAL ADD'L FEE			TOTAL ADD'L FEE		
AMENDMENT C	CLAIMS REMAINING AFTER AMENDMENT	HIGHEST NUMBER PREVIOUSLY PAID FOR	PRESENT EXTRA		RATE	ADDITIONAL FEE		RATE	ADDITIONAL FEE	
	Total (37 CFR 1.16(d))	Minus	**		X \$			X \$		
	Independent (37 CFR 1.16(b))	Minus	***		X \$			X \$		
	FIRST PRESENTATION OF MULTIPLE DEPENDENT CLAIM (37 CFR 1.16(d))					+ \$			+ \$	
* If the entry in column 1 is less than the entry in column 2, write "0" in column 3.					TOTAL ADD'L FEE			TOTAL ADD'L FEE		

This collection of information is required by 37 CFR 1.16. The information is required to obtain or retain a benefit by the public which is to file (and by the USPTO to process) an application. Confidentiality is governed by 35 U.S.C. 122 and 37 CFR 1.14. This collection is estimated to take 12 minutes to complete, including gathering, preparing, and submitting the completed application form to the USPTO. Time will vary depending upon the individual case. Any comments on the amount of time you require to complete this form and/or suggestions for reducing this burden, should be sent to the Chief Information Officer, U.S. Patent and Trademark Office, U.S. Department of Commerce, P.O. Box 1450, Alexandria, VA 22313-1450. DO NOT SEND FEES OR COMPLETED FORMS TO THIS ADDRESS. SEND TO: Commissioner for Patents, P.O. Box 1450, Alexandria, VA 22313-1450.

If you need assistance in completing this form, call 1-800-PTO-9199 and select option 2.



UNITED STATES PATENT AND TRADEMARK OFFICE

UNITED STATES DEPARTMENT OF COMMERCE  
United States Patent and Trademark Office  
Address: COMMISSIONER FOR PATENTS  
P.O. Box 1450  
Alexandria, Virginia 22313-1450  
www.uspto.gov

APPLICATION NO.	FILING DATE	FIRST NAMED INVENTOR	ATTORNEY DOCKET NO.	CONFIRMATION NO.
09/688,501	10/16/2000	Shridhar P. Joshi	47079-00077	3225
30223	7590	01/25/2006	EXAMINER	
JENKENS & GILCHRIST, P.C. 225 WEST WASHINGTON SUITE 2600 CHICAGO, IL 60606			RADA, ALEX P	
			ART UNIT	PAPER NUMBER
			3713	

DATE MAILED: 01/25/2006

Please find below and/or attached an Office communication concerning this application or proceeding.

e

<b>Advisory Action Before the Filing of an Appeal Brief</b>	<b>Application No.</b> 09/688,501	<b>Applicant(s)</b> JOSHI, SHRIDHAR P.	
	<b>Examiner</b> Alex P. Rada	<b>Art Unit</b> 3713	

--The MAILING DATE of this communication appears on the cover sheet with the correspondence address --

THE REPLY FILED 03 January 2006 FAILS TO PLACE THIS APPLICATION IN CONDITION FOR ALLOWANCE.

1.  The reply was filed after a final rejection, but prior to or on the same day as filing a Notice of Appeal. To avoid abandonment of this application, applicant must timely file one of the following replies: (1) an amendment, affidavit, or other evidence, which places the application in condition for allowance; (2) a Notice of Appeal (with appeal fee) in compliance with 37 CFR 41.31; or (3) a Request for Continued Examination (RCE) in compliance with 37 CFR 1.114. The reply must be filed within one of the following time periods:

- a)  The period for reply expires \_\_\_\_\_ months from the mailing date of the final rejection.
- b)  The period for reply expires on: (1) the mailing date of this Advisory Action, or (2) the date set forth in the final rejection, whichever is later. In no event, however, will the statutory period for reply expire later than SIX MONTHS from the mailing date of the final rejection.

Examiner Note: If box 1 is checked, check either box (a) or (b). ONLY CHECK BOX (b) WHEN THE FIRST REPLY WAS FILED WITHIN TWO MONTHS OF THE FINAL REJECTION. See MPEP 706.07(f).

Extensions of time may be obtained under 37 CFR 1.136(a). The date on which the petition under 37 CFR 1.136(a) and the appropriate extension fee have been filed is the date for purposes of determining the period of extension and the corresponding amount of the fee. The appropriate extension fee under 37 CFR 1.17(a) is calculated from: (1) the expiration date of the shortened statutory period for reply originally set in the final Office action; or (2) as set forth in (b) above, if checked. Any reply received by the Office later than three months after the mailing date of the final rejection, even if timely filed, may reduce any earned patent term adjustment. See 37 CFR 1.704(b).

**NOTICE OF APPEAL**

2.  The Notice of Appeal was filed on \_\_\_\_\_. A brief in compliance with 37 CFR 41.37 must be filed within two months of the date of filing the Notice of Appeal (37 CFR 41.37(a)), or any extension thereof (37 CFR 41.37(e)), to avoid dismissal of the appeal. Since a Notice of Appeal has been filed, any reply must be filed within the time period set forth in 37 CFR 41.37(a).

**AMENDMENTS**

3.  The proposed amendment(s) filed after a final rejection, but prior to the date of filing a brief, will not be entered because

- (a)  They raise new issues that would require further consideration and/or search (see NOTE below);
- (b)  They raise the issue of new matter (see NOTE below);
- (c)  They are not deemed to place the application in better form for appeal by materially reducing or simplifying the issues for appeal; and/or
- (d)  They present additional claims without canceling a corresponding number of finally rejected claims.

NOTE: \_\_\_\_\_. (See 37 CFR 1.116 and 41.33(a)).

4.  The amendments are not in compliance with 37 CFR 1.121. See attached Notice of Non-Compliant Amendment (PTOL-324).

5.  Applicant's reply has overcome the following rejection(s): \_\_\_\_\_.

6.  Newly proposed or amended claim(s) \_\_\_\_\_ would be allowable if submitted in a separate, timely filed amendment canceling the non-allowable claim(s).

7.  For purposes of appeal, the proposed amendment(s): a)  will not be entered, or b)  will be entered and an explanation of how the new or amended claims would be rejected is provided below or appended.

The status of the claim(s) is (or will be) as follows:

Claim(s) allowed: \_\_\_\_\_.

Claim(s) objected to: \_\_\_\_\_.

Claim(s) rejected: 37-62.

Claim(s) withdrawn from consideration: \_\_\_\_\_.

**AFFIDAVIT OR OTHER EVIDENCE**

8.  The affidavit or other evidence filed after a final action, but before or on the date of filing a Notice of Appeal will not be entered because applicant failed to provide a showing of good and sufficient reasons why the affidavit or other evidence is necessary and was not earlier presented. See 37 CFR 1.116(e).

9.  The affidavit or other evidence filed after the date of filing a Notice of Appeal, but prior to the date of filing a brief, will not be entered because the affidavit or other evidence failed to overcome all rejections under appeal and/or appellant fails to provide a showing of a good and sufficient reasons why it is necessary and was not earlier presented. See 37 CFR 41.33(d)(1).

10.  The affidavit or other evidence is entered. An explanation of the status of the claims after entry is below or attached.

**REQUEST FOR RECONSIDERATION/OTHER**

11.  The request for reconsideration has been considered but does NOT place the application in condition for allowance because: See Continuation Sheet.

12.  Note the attached Information Disclosure Statement(s). (PTO/SB/08 or PTO-1449) Paper No(s) \_\_\_\_\_.

13.  Other: \_\_\_\_\_.

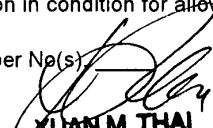
  
**XUAN M. THAI**  
**SUPERVISORY PATENT EXAMINER**  
 T 3700

Continuation of 11. does NOT place the application in condition for allowance because: Applicant contends that the claimed invention is directed toward a remote gaming method and a computer therefore, where players at gaming terminal located outside a gaming establishment may play gaming machines located inside the gaming establishment.

The definition of the word "remote" is separated by an interval or space greater than usual. Wiltshire discloses communication pathways that are remote having any type of local area, wide area, or global communication pathways, including the Internet and th World Wide Web (col. 5, lines 31-33). Thus Wiltshire is capable of a remote gaming method and a computer, where players at gaming terminals located outside (remote) a gaming establishment playing gaming mahcines located inside the gaming establishment. Applicant contends that the examiner has failed to meet the standard for raising a functinally equivalent rejection.

The examiner notes that the statement used in the office action on page 9, lines 5-8 was to make a point that physical gaming machines were re-introcudes as video based gaming machine, which is very commin and very well known in industry today. As noted in the Final office action, when a gaming machine calculates the game results on the gaming machine at a gaming site, the functional equivalent to that would be a gaming machine running a program and the calculations are carried out on a sever located at a gaming a site and routed back to the gaming machine at the gaming site. The only difference is the gaming results are calculated on the server and communicated back to the gaming machine instead of calculating the gaming results at the gaming machine itself. If you take the same computer based video gaming machine and place that video game program on a home PC, the only things that have changed are how the program (results and calculations) are being communicated and how wagers are accepted and payouts awarded. Therefore, a host/server computer executing a casino game program is functionally equivalent to a gaming machine in a gaming establishment..



Docket No.: 47079-00077USPT  
(PATENT)

**IN THE UNITED STATES PATENT AND TRADEMARK OFFICE**

In re Patent Application of:  
Shridhar P. Joshi

Confirmation No: 3225

Application No.: 09/688501

Art Unit: 3714

Filed: October 16, 2000

Examiner: Alex P. Rada

For: METHOD OF TRANSFERRING GAMING  
DATA ON A GLOBAL COMPUTER  
NETWORK

OK TO ENTER  
1-23-06

**RESPONSE TO FINAL OFFICE ACTION**

MS AF  
Commissioner for Patents  
P.O. Box 1450  
Alexandria, VA 22313-1450

Dear Sir:

**INTRODUCTORY COMMENTS**

Responsive to the Final Office Action mailed November 2, 2005, reconsideration and allowance of the present application is respectfully requested in view of the following remarks.

Amendments to the Claims are reflected in the listing of claims that begins on page 2 of this paper.

Remarks/Arguments begin on page 2 of this paper.

CHICAGO 321887v2 47079-00077





AF  
IPW

PTO/SB/31 (04-05)  
Approved for use through 07/31/2006. OMB 0651-0031  
U.S. Patent and Trademark Office; U.S. DEPARTMENT OF COMMERCE  
Under the Paperwork Reduction Act of 1995, no persons are required to respond to a collection of information unless it displays a valid OMB control number

<b>NOTICE OF APPEAL FROM THE EXAMINER TO THE BOARD OF PATENT APPEALS AND INTERFERENCES</b>		Docket Number (Optional) 47079-00077	
In re Application of Bradley A. Rose			
Application Number 09/688501		Filed October 16, 2000	
For METHOD OF TRANSFERRING GAMING DATA ON A GLOBAL COMPUTER NETWORK			
Art Unit 3714		Examiner A. P. Rada	

Applicant hereby **appeals** to the Board of Patent Appeals and Interferences from the last decision of the examiner.

The fee for this Notice of Appeal is (37 CFR 41.20(b)(1)) \$ 500.00

Applicant claims small entity status. See 37 CFR 1.27. Therefore, the fee shown above is reduced by half, and the resulting fee is: \$ \_\_\_\_\_

A check in the amount of the fee is enclosed.

Payment by credit card. Form PTO-2038 is attached.

The Director has already been authorized to charge fees in this application to a Deposit Account. I have enclosed a duplicate copy of this sheet.

The Director is hereby authorized to charge any fees which may be required, or credit any overpayment to Deposit Account No. 10-0447.

A petition for an extension of time under 37 CFR 1.136(a) (PTO/SB/22) is enclosed.

I am the

- applicant /inventor.
- assignee of record of the entire interest.  
See 37 CFR 3.71. Statement under 37 CFR 3.73(b) is enclosed. (Form PTO/SB/96)

attorney or agent of record.  
Registration number 42,933

attorney or agent acting under 37 CFR 1.34.  
Registration number if acting under 37 CFR 1.34. \_\_\_\_\_

Signature

Daniel G. Nguyen  
Typed or printed name

(713) 951-3354  
Telephone number

March 2, 2006  
Date

NOTE: Signatures of all the inventors or assignees of record of the entire interest or their representative(s) are required. Submit multiple forms if more than one signature is required, see below\*.

\*Total of 1 forms are submitted.

03/07/2006 MAHMED1 00000017 09688501  
01 FC:1401 500.00 DP



Under the Paperwork Reduction Act of 1995, no persons are required to respond to a collection of information unless it displays a valid OMB control number.

Application No. (if known): 09/688501

Attorney Docket No.: 47079-00077

### Certificate of Mailing under 37 CFR 1.8

I hereby certify that this correspondence is being deposited with the United States Postal Service with sufficient postage as first class mail in an envelope addressed to:

MS AF  
Commissioner for Patents  
P.O. Box 1450  
Alexandria, VA 22313-1450

on March 2, 2006  
Date

  
Signature

Gwen J. Landry-Witt

Typed or printed name of person signing Certificate

Registration Number, if applicable

(713) 286-2041  
Telephone Number

Note: Each paper must have its own certificate of mailing, or this certificate must identify each submitted paper.

- One Month Request for Extension of Time Under 37 CFR 1.136(a) (1 page)
- Notice of Appeal (1 page)
- Transmittal (1 page)
- Fee Transmittal Form (1 page)
- Check in the amount of \$620.00



PTO/SB/21 (09-04)

Approved for use through 07/31/2006. OMB 0651-0031  
 U.S. Patent and Trademark Office; U.S. DEPARTMENT OF COMMERCE

Under the Paperwork Reduction Project of 1995, no persons are required to respond to a collection of information unless it displays a valid OMB control number.

<h1>TRANSMITTAL FORM</h1> <p><i>(to be used for all correspondence after initial filing)</i></p>	Application Number	09/688501	
	Filing Date	October 16, 2000	
	First Named Inventor	Bradley A. Rose	
	Art Unit	3714	
	Examiner Name	A. P. Rada	
Total Number of Pages in This Submission	6	Attorney Docket Number	47079-00077

ENCLOSURES (Check all that apply)		
<input checked="" type="checkbox"/> Fee Transmittal Form <input checked="" type="checkbox"/> Fee Attached <input type="checkbox"/> Amendment/Reply <input type="checkbox"/> After Final <input type="checkbox"/> Affidavits/declaration(s) <input checked="" type="checkbox"/> Extension of Time Request <input type="checkbox"/> Express Abandonment Request <input type="checkbox"/> Information Disclosure Statement <input type="checkbox"/> Certified Copy of Priority Document(s) <input type="checkbox"/> Reply to Missing Parts/Incomplete Application <input type="checkbox"/> Reply to Missing Parts under 37 CFR 1.52 or 1.53	<input type="checkbox"/> Drawing(s) <input type="checkbox"/> Licensing-related Papers <input type="checkbox"/> Petition <input type="checkbox"/> Petition to Convert to a Provisional Application <input type="checkbox"/> Power of Attorney, Revocation Change of Correspondence Address <input type="checkbox"/> Terminal Disclaimer <input type="checkbox"/> Request for Refund <input type="checkbox"/> CD, Number of CD(s) _____ <input type="checkbox"/> Landscape Table on CD	<input type="checkbox"/> After Allowance Communication to TC <input type="checkbox"/> Appeal Communication to Board of Appeals and Interferences <input checked="" type="checkbox"/> Appeal Communication to TC (Appeal Notice, Brief, Reply Brief) <input type="checkbox"/> Proprietary Information <input type="checkbox"/> Status Letter <input checked="" type="checkbox"/> Other Enclosure(s) (please identify below): Return Receipt Postcard
Remarks		

SIGNATURE OF APPLICANT, ATTORNEY, OR AGENT			
Firm Name	JENKENS & GILCHRIST, A PROFESSIONAL CORPORATION		
Signature			
Printed name	Daniel G. Nguyen		
Date	March 2, 2006	Reg. No.	42,933

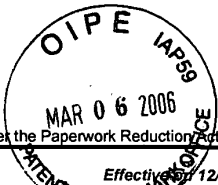

Under the Paperwork Reduction Act of 1995, no person are required to respond to a collection of information unless it displays a valid OMB control number.

Effective 12/08/2004. Fees pursuant to the Consolidated Appropriations Act, 2005 (H.R. 4818). <b>FEE TRANSMITTAL</b> <b>For FY 2005</b>	<b>Complete if Known</b>	
	Application Number	09/688501
	Filing Date	October 16, 2000
	First Named Inventor	Bradley A. Rose
	Examiner Name	A. P. Rada
<input type="checkbox"/> Applicant claims small entity status. See 37 CFR 1.27	Art Unit	3714
<b>TOTAL AMOUNT OF PAYMENT</b>	<b>(\$)</b> 620.00	Attorney Docket No. 47079-00077

**METHOD OF PAYMENT** (check all that apply)

Check  
  Credit Card  
  Money Order  
  None  
  Other (please identify): \_\_\_\_\_

Deposit Account  
 Deposit Account Number: 10-0447  
 Deposit Account Name: Jenkins & Gilchrist, a Professional Corporation

For the above-identified deposit account, the Director is hereby authorized to: (check all that apply)

Charge fee(s) indicated below  
  Charge fee(s) indicated below, **except for the filing fee**

Charge any additional fee(s) or underpayment of fee(s) under 37 CFR 1.16 and 1.17  
  Credit any overpayments

**FEE CALCULATION**

**1. BASIC FILING, SEARCH, AND EXAMINATION FEES**

Application Type	FILING FEES		SEARCH FEES		EXAMINATION FEES		Fees Paid (\$)
	Fee (\$)	Small Entity Fee (\$)	Fee (\$)	Small Entity Fee (\$)	Fee (\$)	Small Entity Fee (\$)	
Utility	300	150	500	250	200	100	_____
Design	200	100	100	50	130	65	_____
Plant	200	100	300	150	160	80	_____
Reissue	300	150	500	250	600	300	_____
Provisional	200	100	0	0	0	0	_____

**2. EXCESS CLAIM FEES**

Fee Description	Small Entity	
	Fee (\$)	Fee (\$)
Each claim over 20 (including Reissues)	50	25
Each independent claim over 3 (including Reissues)	200	100
Multiple dependent claims	360	180

Total Claims    Extra Claims    Fee (\$)    =    Fee Paid (\$)  
 62    - 62 = \_\_\_\_\_ x \_\_\_\_\_ = \_\_\_\_\_

Multiple Dependent Claims  
Fee (\$)    Fee Paid (\$)  
 \_\_\_\_\_    \_\_\_\_\_

Indep. Claims    Extra Claims    Fee (\$)    =    Fee Paid (\$)  
 4    - 7 = \_\_\_\_\_ x \_\_\_\_\_ = \_\_\_\_\_

**3. APPLICATION SIZE FEE**

If the specification and drawings exceed 100 sheets of paper (excluding electronically filed sequence or computer listings under 37 CFR 1.52(e)), the application size fee due is \$250 (\$125 for small entity) for each additional 50 sheets or fraction thereof. See 35 U.S.C. 41(a)(1)(G) and 37 CFR 1.16(s).

Total Sheets	Extra Sheets	Number of each additional 50 or fraction thereof	Fee (\$)	Fee Paid (\$)
_____	- 100 = _____	/50 _____ (round up to a whole number) x _____	= _____	_____

**4. OTHER FEE(S)**

	Fees Paid (\$)
Non-English Specification, \$130 fee (no small entity discount)	
Other (e.g., late filing surcharge): 1251 Extension for response within first month	120.00
1401 Notice of appeal	500.00

**SUBMITTED BY**

Signature	<i>Daniel G. Nguyen</i>	Registration No. (Attorney/Agent)	42,933	Telephone	(713) 951-3354
Name (Print/Type)	Daniel G. Nguyen	Date	March 2, 2006		

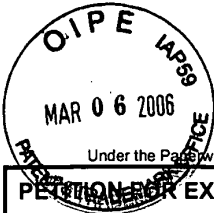

Under the Paperwork Reduction Act of 1995, no persons are required to respond to a collection of information unless it displays a valid OMB control number.

<b>PETITION FOR EXTENSION OF TIME UNDER 37 CFR 1.136(a) FY 2005</b> (Fees pursuant to the Consolidated Appropriations Act, 2005 (H.R. 4818).)		Docket Number (Optional) 47079-00077																									
Application Number 09/688501		Filed October 16, 2000																									
For METHOD OF TRANSFERRING GAMING DATA ON A GLOBAL COMPUTER NETWORK																											
Art Unit 3714		Examiner A. P. Rada																									
<p>This is a request under the provisions of 37 CFR 1.136(a) to extend the period for filing a reply in the above identified application.</p> <p>The requested extension and fee are as follows (check time period desired and enter the appropriate fee below):</p> <table style="width: 100%; border-collapse: collapse;"> <thead> <tr> <th style="width: 60%;"></th> <th style="text-align: center; width: 15%;">Fee</th> <th style="text-align: center; width: 15%;">Small Entity Fee</th> <th style="width: 10%;"></th> </tr> </thead> <tbody> <tr> <td><input checked="" type="checkbox"/> One month (37 CFR 1.17(a)(1))</td> <td style="text-align: center;">\$120</td> <td style="text-align: center;">\$60</td> <td style="text-align: center;">\$ 120.00</td> </tr> <tr> <td><input type="checkbox"/> Two months (37 CFR 1.17(a)(2))</td> <td style="text-align: center;">\$450</td> <td style="text-align: center;">\$225</td> <td style="text-align: center;">\$</td> </tr> <tr> <td><input type="checkbox"/> Three months (37 CFR 1.17(a)(3))</td> <td style="text-align: center;">\$1020</td> <td style="text-align: center;">\$510</td> <td style="text-align: center;">\$</td> </tr> <tr> <td><input type="checkbox"/> Four months (37 CFR 1.17(a)(4))</td> <td style="text-align: center;">\$1590</td> <td style="text-align: center;">\$795</td> <td style="text-align: center;">\$</td> </tr> <tr> <td><input type="checkbox"/> Five months (37 CFR 1.17(a)(5))</td> <td style="text-align: center;">\$2160</td> <td style="text-align: center;">\$1080</td> <td style="text-align: center;">\$</td> </tr> </tbody> </table> <p><input type="checkbox"/> Applicant claims small entity status. See 37 CFR 1.27.</p> <p><input checked="" type="checkbox"/> A check in the amount of the fee is enclosed.</p> <p><input type="checkbox"/> Payment by credit card. Form PTO-2038 is attached.</p> <p><input type="checkbox"/> The Director has already been authorized to charge fees in this application to a Deposit Account.</p> <p><input checked="" type="checkbox"/> The Director is hereby authorized to charge any fees which may be required, or credit any overpayment, to Deposit Account Number <u>10-0447</u></p> <p>(Dep. Acct. Ref.: 47079-00077 – D.Burnham)</p> <p>I am the <input type="checkbox"/> applicant/inventor.</p> <p><input type="checkbox"/> assignee of record of the entire interest. See 37 CFR 3.71. Statement under 37 CFR 3.73(b) is enclosed. (Form PTO/SB/96).</p> <p><input checked="" type="checkbox"/> attorney or agent of record. Registration Number <u>42,933</u></p> <p><input type="checkbox"/> attorney or agent under 37 CFR 1.34. Registration number if acting under 37 CFR 1.34 _____</p> <p style="text-align: center;"><u>Daniel Nguyen</u> Signature</p> <p style="text-align: center;">March 2, 2006 Date</p> <p style="text-align: center;"><u>Daniel G. Nguyen</u> Typed or printed name</p> <p style="text-align: center;">(713) 951-3354 Telephone Number</p> <p>NOTE: Signatures of all the inventors or assignees of record of the entire interest or their representative(s) are required. Submit multiple forms if more than one signature is required, see below.</p> <p><input type="checkbox"/> Total of <u>1</u> forms are submitted.</p>					Fee	Small Entity Fee		<input checked="" type="checkbox"/> One month (37 CFR 1.17(a)(1))	\$120	\$60	\$ 120.00	<input type="checkbox"/> Two months (37 CFR 1.17(a)(2))	\$450	\$225	\$	<input type="checkbox"/> Three months (37 CFR 1.17(a)(3))	\$1020	\$510	\$	<input type="checkbox"/> Four months (37 CFR 1.17(a)(4))	\$1590	\$795	\$	<input type="checkbox"/> Five months (37 CFR 1.17(a)(5))	\$2160	\$1080	\$
	Fee	Small Entity Fee																									
<input checked="" type="checkbox"/> One month (37 CFR 1.17(a)(1))	\$120	\$60	\$ 120.00																								
<input type="checkbox"/> Two months (37 CFR 1.17(a)(2))	\$450	\$225	\$																								
<input type="checkbox"/> Three months (37 CFR 1.17(a)(3))	\$1020	\$510	\$																								
<input type="checkbox"/> Four months (37 CFR 1.17(a)(4))	\$1590	\$795	\$																								
<input type="checkbox"/> Five months (37 CFR 1.17(a)(5))	\$2160	\$1080	\$																								

03/07/2006 MAHMED1 00000017 09688501

02 FC:1251

120.00 0P



UNITED STATES PATENT AND TRADEMARK OFFICE

UNITED STATES DEPARTMENT OF COMMERCE  
United States Patent and Trademark Office  
Address: COMMISSIONER FOR PATENTS  
P.O. Box 1450  
Alexandria, Virginia 22313-1450  
www.uspto.gov

APPLICATION NO.	FILING DATE	FIRST NAMED INVENTOR	ATTORNEY DOCKET NO.	CONFIRMATION NO.
09/688,501	10/16/2000	Shridhar P. Joshi	47079-00077	3225

30223 7590 03/07/2006

JENKENS & GILCHRIST, P.C.  
225 WEST WASHINGTON  
SUITE 2600  
CHICAGO, IL 60606

EXAMINER

RADA, ALEX P

ART UNIT PAPER NUMBER

3713

DATE MAILED: 03/07/2006

Please find below and/or attached an Office communication concerning this application or proceeding.

<b>Interview Summary</b>	<b>Application No.</b>	<b>Applicant(s)</b>	
	09/688,501	JOSHI, SHRIDHAR P.	
	<b>Examiner</b>	<b>Art Unit</b>	
	Alex P. Rada	3713	

All participants (applicant, applicant's representative, PTO personnel):

- (1) Alex P. Rada. (3) Corbett Coburn (Primary).  
(2) Daniel G. Nguyen. (4) \_\_\_\_\_.

Date of Interview: 01 March 2006.

Type: a)  Telephonic b)  Video Conference  
c)  Personal [copy given to: 1)  applicant 2)  applicant's representative]

Exhibit shown or demonstration conducted: d)  Yes e)  No.  
If Yes, brief description: \_\_\_\_\_.

Claim(s) discussed: 37 and 52.

Identification of prior art discussed: Wiltshire et al, Walker et al., and Karmarkar.

Agreement with respect to the claims f)  was reached. g)  was not reached. h)  N/A.

Substance of Interview including description of the general nature of what was agreed to if an agreement was reached, or any other comments: See Continuation Sheet.

(A fuller description, if necessary, and a copy of the amendments which the examiner agreed would render the claims allowable, if available, must be attached. Also, where no copy of the amendments that would render the claims allowable is available, a summary thereof must be attached.)

THE FORMAL WRITTEN REPLY TO THE LAST OFFICE ACTION MUST INCLUDE THE SUBSTANCE OF THE INTERVIEW. (See MPEP Section 713.04). If a reply to the last Office action has already been filed, APPLICANT IS GIVEN A NON-EXTENDABLE PERIOD OF THE LONGER OF ONE MONTH OR THIRTY DAYS FROM THIS INTERVIEW DATE, OR THE MAILING DATE OF THIS INTERVIEW SUMMARY FORM, WHICHEVER IS LATER, TO FILE A STATEMENT OF THE SUBSTANCE OF THE INTERVIEW. See Summary of Record of Interview requirements on reverse side or on attached sheet.

Examiner Note: You must sign this form unless it is an Attachment to a signed Office action.

  
\_\_\_\_\_  
Examiner's signature, if required

## Summary of Record of Interview Requirements

### Manual of Patent Examining Procedure (MPEP), Section 713.04, Substance of Interview Must be Made of Record

A complete written statement as to the substance of any face-to-face, video conference, or telephone interview with regard to an application must be made of record in the application whether or not an agreement with the examiner was reached at the interview.

### Title 37 Code of Federal Regulations (CFR) § 1.133 Interviews Paragraph (b)

In every instance where reconsideration is requested in view of an interview with an examiner, a complete written statement of the reasons presented at the interview as warranting favorable action must be filed by the applicant. An interview does not remove the necessity for reply to Office action as specified in §§ 1.111, 1.135. (35 U.S.C. 132)

### 37 CFR §1.2 Business to be transacted in writing.

All business with the Patent or Trademark Office should be transacted in writing. The personal attendance of applicants or their attorneys or agents at the Patent and Trademark Office is unnecessary. The action of the Patent and Trademark Office will be based exclusively on the written record in the Office. No attention will be paid to any alleged oral promise, stipulation, or understanding in relation to which there is disagreement or doubt.

The action of the Patent and Trademark Office cannot be based exclusively on the written record in the Office if that record is itself incomplete through the failure to record the substance of interviews.

It is the responsibility of the applicant or the attorney or agent to make the substance of an interview of record in the application file, unless the examiner indicates he or she will do so. It is the examiner's responsibility to see that such a record is made and to correct material inaccuracies which bear directly on the question of patentability.

Examiners must complete an Interview Summary Form for each interview held where a matter of substance has been discussed during the interview by checking the appropriate boxes and filling in the blanks. Discussions regarding only procedural matters, directed solely to restriction requirements for which interview recordation is otherwise provided for in Section 812.01 of the Manual of Patent Examining Procedure, or pointing out typographical errors or unreadable script in Office actions or the like, are excluded from the interview recordation procedures below. Where the substance of an interview is completely recorded in an Examiners Amendment, no separate Interview Summary Record is required.

The Interview Summary Form shall be given an appropriate Paper No., placed in the right hand portion of the file, and listed on the "Contents" section of the file wrapper. In a personal interview, a duplicate of the Form is given to the applicant (or attorney or agent) at the conclusion of the interview. In the case of a telephone or video-conference interview, the copy is mailed to the applicant's correspondence address either with or prior to the next official communication. If additional correspondence from the examiner is not likely before an allowance or if other circumstances dictate, the Form should be mailed promptly after the interview rather than with the next official communication.

The Form provides for recordation of the following information:

- Application Number (Series Code and Serial Number)
- Name of applicant
- Name of examiner
- Date of interview
- Type of interview (telephonic, video-conference, or personal)
- Name of participant(s) (applicant, attorney or agent, examiner, other PTO personnel, etc.)
- An indication whether or not an exhibit was shown or a demonstration conducted
- An identification of the specific prior art discussed
- An indication whether an agreement was reached and if so, a description of the general nature of the agreement (may be by attachment of a copy of amendments or claims agreed as being allowable). Note: Agreement as to allowability is tentative and does not restrict further action by the examiner to the contrary.
- The signature of the examiner who conducted the interview (if Form is not an attachment to a signed Office action)

It is desirable that the examiner orally remind the applicant of his or her obligation to record the substance of the interview of each case. It should be noted, however, that the Interview Summary Form will not normally be considered a complete and proper recordation of the interview unless it includes, or is supplemented by the applicant or the examiner to include, all of the applicable items required below concerning the substance of the interview.

A complete and proper recordation of the substance of any interview should include at least the following applicable items:

- 1) A brief description of the nature of any exhibit shown or any demonstration conducted,
- 2) an identification of the claims discussed,
- 3) an identification of the specific prior art discussed,
- 4) an identification of the principal proposed amendments of a substantive nature discussed, unless these are already described on the Interview Summary Form completed by the Examiner,
- 5) a brief identification of the general thrust of the principal arguments presented to the examiner,  
(The identification of arguments need not be lengthy or elaborate. A verbatim or highly detailed description of the arguments is not required. The identification of the arguments is sufficient if the general nature or thrust of the principal arguments made to the examiner can be understood in the context of the application file. Of course, the applicant may desire to emphasize and fully describe those arguments which he or she feels were or might be persuasive to the examiner.)
- 6) a general indication of any other pertinent matters discussed, and
- 7) if appropriate, the general results or outcome of the interview unless already described in the Interview Summary Form completed by the examiner.

Examiners are expected to carefully review the applicant's record of the substance of an interview. If the record is not complete and accurate, the examiner will give the applicant an extendable one month time period to correct the record.

### Examiner to Check for Accuracy

If the claims are allowable for other reasons of record, the examiner should send a letter setting forth the examiner's version of the statement attributed to him or her. If the record is complete and accurate, the examiner should place the indication, "Interview Record OK" on the paper recording the substance of the interview along with the date and the examiner's initials.



Continuation of Substance of Interview including description of the general nature of what was agreed to if an agreement was reached, or any other comments: Applicant further elaborated on the claimed invention. Applicant faxed proposed amendments for discussion. The examiner noted that the Wiltshire reference would still meet the proposed amended claims. The examiner suggested language along the lines of the server and the physical gaming machine co-existing or within the same gaming establishment. The proposed language might over the reference Wiltshire pending further searching and consideration. The examiner also noted the Kamarkar reference to applicant. Proposed arguments and amendments would be taken into consideration upon filing a response pending further consideration and searching.

# Jenkins & Gilchrist

A PROFESSIONAL CORPORATION

1401 MCKINNEY  
SUITE 2600  
HOUSTON, TEXAS 77010-4034

(713) 951-3300  
FACSIMILE (713) 951-3314

www.jenkins.com

AUSTIN, TEXAS

CHICAGO, ILLINOIS

DALLAS, TEXAS

LOS ANGELES, CALIFORNIA

PASADENA, CALIFORNIA

SAN ANTONIO, TEXAS

WASHINGTON, D.C.

FROM THE DESK OF:  
Daniel G. Nguyen  
(713) 951-3354

RECIPIENT	COMPANY	FAX NO.	PHONE NO.
1. Examiner Alex P. Rada		571-273-4452	571-272-4452

• MESSAGE •

Examiner Rada,

I would be grateful for a telephone interview to discuss these proposed claim amendments at your convenience. I would like to talk specifically about the main benefit derived from the claimed invention, namely, that a person would be able to leave a casino, go home to another city or state, and still play the same gaming machine he/she played while in the casino. This aspect would be particularly important if the person developed a special affinity for a specific gaming machine while he/she was in the casino. I don't think this benefit would be possible with the prior art references of record.

Daniel G. Nguyen

**NOTICE OF CONFIDENTIALITY**

The information contained in and transmitted with this facsimile is

1. SUBJECT TO THE ATTORNEY-CLIENT PRIVILEGE;
2. ATTORNEY WORK PRODUCT; OR
3. CONFIDENTIAL.

It is intended only for the individual or entity designated above. You are hereby notified that any dissemination, distribution, copying, or use of or reliance upon the information contained in and transmitted with this facsimile by or to anyone other than the recipient designated above by the sender is *unauthorized* and *strictly prohibited*. If you have received this facsimile in error, please notify Jenkins & Gilchrist, a professional corporation by telephone at (713) 951-3300 immediately. Any facsimile erroneously transmitted to you should be immediately returned to the sender by U.S. Mail, or if authorization is granted by the sender, destroyed.

Time: 6:35 PM

Date: February 23, 2006

Emp #: 3986

Billing #: 47079-00077

Total Pages (+ Cover): 6

Docket No.: 47079-00077USPT  
(PATENT)

**IN THE UNITED STATES PATENT AND TRADEMARK OFFICE**

In re Patent Application of:  
Shridhar P. Joshi

Confirmation No: 3225

Application No.: 09/688501

Art Unit: 3714

Filed: October 16, 2000

Examiner: Alex P. Rada

For: METHOD OF TRANSFERRING GAMING  
DATA ON A GLOBAL COMPUTER  
NETWORK

**PROPOSED AMENDMENTS FOR TELEPHONE INTERVIEW**

Claims 1-36. (Cancelled)

37. (Currently Amended) A remote gaming method comprising:  
accessing, via a remote terminal, a gaming site on a global computer network connected to said remote terminal;  
providing, via said remote terminal, personal identification information to said gaming site;  
selecting, via said remote terminal, a game of chance from a plurality of physical gaming machines located at a gaming establishment for remote play, said remote terminal being located outside said gaming establishment, said physical gaming machines playable by a player at said gaming establishment;  
placing, via said remote terminal, a wager for playing said selected game; and  
receiving randomly-generated text or graphical outcome data at said remote terminal for said selected game, said outcome data being generated by one of said plurality of physical gaming machines at said gaming establishment and relayed to said gaming site through a gaming server connected to said gaming site.
38. (Currently Amended) A remote gaming method using a gaming server, a remote terminal, and a gaming site on a global computer network, said gaming server being located at a gaming

Application No.: 09/688501

Docket No.: 47079-00077USPT

establishment, said remote terminal being located outside said gaming establishment, said gaming site being provided on said global computer network, the method comprising:

receiving, at said gaming server, personal identification information, game selection information, and wager information from a player accessing said gaming site via said remote terminal, said remote terminal being connected to said global computer network;

randomly generating outcome data at one of a plurality of physical gaming machines communicatively coupled to said gaming server, said outcome data being generated for a game selected according to said game selection information, said plurality of physical gaming machines being located at said gaming establishment and playable by said player at said gaming establishment;

receiving said outcome data at said gaming server; and

transmitting said outcome data from said gaming server to said gaming site for display to said player on said remote terminal in text or graphical form.

39. (Currently Amended) A method for playing a physical gaming machine located inside a gaming establishment from a remote terminal located outside the gaming establishment comprising:

establishing a communication link between said remote terminal and a gaming site on a global computer network, said gaming site in communication with a gaming server for collecting outcome data from physical gaming machines located inside the gaming establishment;

selecting a physical gaming machine at said gaming establishment using said remote terminal;

making a wager to play the selected physical gaming machine;

receiving outcome data, including game outcome, at said remote terminal resulting from a play of said physical gaming machine; and

generating a payout if said game outcome meets predetermined criteria.

40. (Previously Presented) The method of claim 39 wherein said outcome data comprises information identifying the value of said payout; and further comprising the step of using said payout information to simulate a display of said game outcome at said remote location.

Application No.: 09/688501

Docket No.: 47079-00077USPT

41. (Previously Presented) The method of claim 39 further comprising using said outcome data to simulate a display of said game outcome on said remote terminal.
42. (Previously Presented) The method of claim 39, wherein said selected gaming machine comprises a slot machine and wherein said game outcome data includes a reel position.
43. (Previously Presented) The method of claim 39 wherein said selected gaming machine comprises a video poker machine including a display for displaying a poker hand.
44. (Previously Presented) The method of claim 39 wherein said step of receiving outcome data includes receiving outcome data from a plurality of gaming machines for remote play.
45. (Previously Presented) The method of claim 44 wherein said step of receiving outcome data includes receiving a gaming machine identifier.
46. (Previously Presented) The method of claim 44 wherein said step of receiving outcome data includes receiving a gaming machine type.
47. (Previously Presented) The method of claim 44 wherein said step of receiving outcome data includes receiving player preferences.
48. (Previously Presented) The method of claim 39 wherein said selected gaming machine comprises a slot machine and wherein said game outcome comprises information identifying a reel position of said gaming machine; and further comprising the step of using said outcome information to display said reel position on said remote terminal.
49. (Previously Presented) The method of claim 39 and further including the steps of receiving a player identifier; and transmitting said player identifier for identification of said player.
50. (Previously Presented) The method of claim 39 wherein said game outcome results from the server initiating game play on the selected gaming machine.
51. (Previously Presented) The method of claim 39 wherein said game outcome results from the manual game play on the selected gaming machine.

Application No.: 09/688501

Docket No.: 47079-00077USPT

52. (Currently Amended) A remote computer for the remote play of a physical gaming machine located within a gaming establishment and connected to a gaming server, the remote computer being located outside said gaming establishment, said remote computer connected to a gaming site through a global computing network served by said gaming server, said remote computer comprising:

Deleted: local

a microprocessor;  
memory connected to said microprocessor and including instructions for controlling said microprocessor; and

said microprocessor being operative with said instructions in said memory to:  
receive information identifying a plurality of physical gaming machines located within said gaming establishment from a gaming server, said physical gaming machine playable by a player at said gaming establishment;

Deleted: local

transmit data selecting of at least one said plurality of physical gaming machines for remote play;

Deleted: local

receive a text or graphical outcome resulting from a local play of each said selected physical gaming machine; and  
generate a payout if said outcome meets predetermined criteria.

Deleted: local

53. (Previously Presented) The remote computer of claim 52 wherein said selected gaming machine comprises a slot machine and wherein said outcome includes a reel position.

54. (Previously Presented) The remote computer of claim 52 wherein said operation of receiving information includes receiving information selecting at least two of said plurality of local gaming machines for remote play.

55. (Previously Presented) The remote computer of claim 52 wherein said operation of receiving information includes receiving a gaming machine identifier.

56. (Previously Presented) The remote computer of claim 52 wherein said operation of receiving information includes receiving a gaming machine type.

57. (Previously Presented) The remote computer of claim 52 wherein said operation of receiving information includes receiving player preferences.

Application No.: 09/688501

Docket No.: 47079-00077USPT

58. (Previously Presented) The remote computer of claim 52 wherein said selected gaming machine comprises a video poker machine including a display for displaying a poker hand.

59. (Previously Presented) The remote computer of claim 52 wherein said outcome comprises data identifying the value of said payout; and further comprising the operation of using said payout data to simulate a display of said outcome at said remote location.

60. (Previously Presented) The remote computer of claim 52 wherein said outcome comprises information identifying a reel position of said selected gaming machine; and further comprising the operation of using said outcome data to display said reel position at said remote location.

61. (Previously Presented) The remote computer of claim 52 further including the operations of: receiving a player identifier; and transmitting said player identifier for identification of said player.

62. (Currently Amended) A remote computer located outside a gaming establishment, said gaming establishment having a plurality of physical gaming machines linked by a gaming server, said remote computer connected to a gaming site through a global computing network served by said gaming server comprising:

means for receiving information identifying a plurality of physical gaming machines each engaged in play by a player within said gaming establishment;

means for transmitting data from said remote computer for selecting at least one of said plurality of physical gaming machines for information transfer;

means for receiving a text or graphical outcome resulting from a play of said selected physical gaming machines; and

for generating a payout if said outcome meets predetermined criteria.

Deleted: local

Deleted: local

Deleted: local

I hereby certify that this paper (along with any paper referred to as being attached or enclosed) is being deposited with the U.S. Postal Service on the date shown below with sufficient postage as First Class Mail, in an envelope addressed to: Commissioner for Patents, P.O. Box 1450, Alexandria, VA 22313-1450.

Dated: April 7, 2006

Signature:

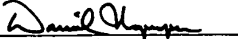
  
Daniel G. Nguyen

1FW 3714  
Docket No.: 47079-00077USPT  
(PATENT)

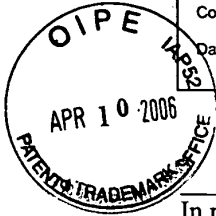

**IN THE UNITED STATES PATENT AND TRADEMARK OFFICE**

In re Patent Application of:  
Bradley A. Rose

Application No.: 09/688501

Group Art Unit: 3714

Filed: October 16, 2000

Examiner: A. P. Rada

For: METHOD OF TRANSFERRING GAMING  
DATA ON A GLOBAL COMPUTER  
NETWORK

**TRANSMITTAL LETTER**

Commissioner for Patents  
P.O. Box 1450  
Alexandria, VA 22313-1450

Dear Sir:

Enclosed are the following items for filing in connection with the above-referenced Patent Application:

1. Statement of substance of interview (6 pages)
2. Acknowledgement postcard

The Director is hereby authorized to charge any deficiency in the fees filed, asserted to be filed or which should have been filed herewith (or with any paper hereafter filed in this application by this firm) to our Deposit Account No. 10-0447, under Order No. 47079-00077USPT.

Dated: April 7, 2006

Respectfully submitted,

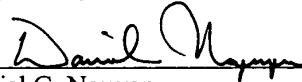
By   
Daniel G. Nguyen

Registration No.: 42,933  
JENKENS & GILCHRIST, A PROFESSIONAL  
CORPORATION  
225 W. Washington, Ste. 2600  
Chicago, Illinois 60606-3418  
(312) 425-3900  
Attorneys For Applicant

CHICAGO 327593v1 47079-00077



I hereby certify that this paper (along with any paper referred to as being attached or enclosed) is being deposited with the U.S. Postal Service on the date shown below with sufficient postage as First Class Mail, in an envelope addressed to: Commissioner for Patents, P.O. Box 1450, Alexandria, VA 22313-1450.

Dated: April 7, 2006

Signature: Daniel G. Nguyen  
Daniel G. Nguyen

Docket No.: 47079-00077USPT  
(PATENT)

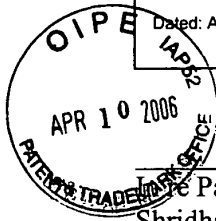

**IN THE UNITED STATES PATENT AND TRADEMARK OFFICE**

Patent Application of:  
Shridhar P. Joshi

Confirmation No: 3225

Application No.: 09/688501

Art Unit: 3714

Filed: October 16, 2000

Examiner: Alex P. Rada

For: METHOD OF TRANSFERRING GAMING  
DATA ON A GLOBAL COMPUTER  
NETWORK

**STATEMENT OF SUBSTANCE OF INTERVIEW**

Commissioner for Patents  
P.O. Box 1450  
Alexandria, VA 22313-1450

Dear Sir:

Applicant submits this Statement of Substance of Interview in accordance with 37 CFR 1.133(b), MPEP § 502.03 and § 713.01 for a telephone interview on March 1, 2006, regarding Applicant's proposed claim amendments (reproduced herewith). During said interview, Applicant attempted to explain various player benefits that are available only through the remote gaming system/method of the claimed invention, including the ability to play the same "lucky" gaming machine in both a gaming establishment **and** from at home. No agreement was reached and the proposed amendments were not entered. Applicant thanks the Examiner for the courtesy extended during the telephone interview.

Dated: April 7, 2006

Respectfully submitted,

By Daniel G. Nguyen  
Daniel G. Nguyen

Registration No.: 42,933  
JENKENS & GILCHRIST, A PROFESSIONAL  
CORPORATION  
225 W. Washington, Ste. 2600  
Chicago, Illinois 60606-3418  
(713) 951-3354  
(713) 951-3314 Facsimile  
Attorneys For Applicant

**PROPOSED AMENDMENTS DISCUSSED DURING TELEPHONE INTERVIEW**

Claims 1-36. (Cancelled)

37. (Currently Amended) A remote gaming method comprising:  
accessing, via a remote terminal, a gaming site on a global computer network connected to said remote terminal;  
providing, via said remote terminal, personal identification information to said gaming site;  
selecting, via said remote terminal, a game of chance from a plurality of physical gaming machines located at a gaming establishment for remote play, said remote terminal being located outside said gaming establishment, said physical gaming machines playable by a player at said gaming establishment;  
placing, via said remote terminal, a wager for playing said selected game; and  
receiving randomly-generated text or graphical outcome data at said remote terminal for said selected game, said outcome data being generated by one of said plurality of physical gaming machines at said gaming establishment and relayed to said gaming site through a gaming server connected to said gaming site.

38. (Currently Amended) A remote gaming method using a gaming server, a remote terminal, and a gaming site on a global computer network, said gaming server being located at a gaming establishment, said remote terminal being located outside said gaming establishment, said gaming site being provided on said global computer network, the method comprising:

receiving, at said gaming server, personal identification information, game selection information, and wager information from a player accessing said gaming site via said remote terminal, said remote terminal being connected to said global computer network;

randomly generating outcome data at one of a plurality of physical gaming machines communicatively coupled to said gaming server, said outcome data being generated for a game selected according to said game selection information, said plurality of physical gaming machines being located at said gaming establishment and playable by said player at said gaming establishment;

receiving said outcome data at said gaming server; and

transmitting said outcome data from said gaming server to said gaming site for display to said player on said remote terminal in text or graphical form.

39. (Currently Amended) A method for playing a physical gaming machine located inside a gaming establishment from a remote terminal located outside the gaming establishment comprising: establishing a communication link between said remote terminal and a gaming site on a global computer network, said gaming site in communication with a gaming server for collecting outcome data from physical gaming machines located inside the gaming establishment; selecting a physical gaming machine at said gaming establishment using said remote terminal; making a wager to play the selected physical gaming machine; receiving outcome data, including game outcome, at said remote terminal resulting from a play of said physical gaming machine; and generating a payout if said game outcome meets predetermined criteria.

40. (Previously Presented) The method of claim 39 wherein said outcome data comprises information identifying the value of said payout; and further comprising the step of using said payout information to simulate a display of said game outcome at said remote location.

41. (Previously Presented) The method of claim 39 further comprising using said outcome data to simulate a display of said game outcome on said remote terminal.

42. (Previously Presented) The method of claim 39, wherein said selected gaming machine comprises a slot machine and wherein said game outcome data includes a reel position.

43. (Previously Presented) The method of claim 39 wherein said selected gaming machine comprises a video poker machine including a display for displaying a poker hand.

44. (Previously Presented) The method of claim 39 wherein said step of receiving outcome data includes receiving outcome data from a plurality of gaming machines for remote play.

45. (Previously Presented) The method of claim 44 wherein said step of receiving outcome data includes receiving a gaming machine identifier.

46. (Previously Presented) The method of claim 44 wherein said step of receiving outcome data includes receiving a gaming machine type.

47. (Previously Presented) The method of claim 44 wherein said step of receiving outcome data includes receiving player preferences.

48. (Previously Presented) The method of claim 39 wherein said selected gaming machine comprises a slot machine and wherein said game outcome comprises information identifying a reel position of said gaming machine; and further comprising the step of using said outcome information to display said reel position on said remote terminal.

49. (Previously Presented) The method of claim 39 and further including the steps of receiving a player identifier; and transmitting said player identifier for identification of said player.

50. (Previously Presented) The method of claim 39 wherein said game outcome results from the server initiating game play on the selected gaming machine.

51. (Previously Presented) The method of claim 39 wherein said game outcome results from the manual game play on the selected gaming machine.

52. (Currently Amended) A remote computer for the remote play of a ~~local-physical~~ gaming machine located within a gaming establishment and connected to a gaming server, the remote computer being located outside said gaming establishment, said remote computer connected to a gaming site through a global computing network served by said gaming server, said remote computer comprising:

a microprocessor;

memory connected to said microprocessor and including instructions for controlling said microprocessor; and

said microprocessor being operative with said instructions in said memory to:

receive information identifying a plurality of ~~local-physical~~ gaming machines located within said gaming establishment from a gaming server, said physical gaming machine playable by a player at said gaming establishment;

transmit data selecting of at least one said plurality of ~~local-physical~~ gaming machines for remote play;

receive a text or graphical outcome resulting from a local play of each said selected ~~local-physical~~ gaming machine; and

generate a payout if said outcome meets predetermined criteria.

53. (Previously Presented) The remote computer of claim 52 wherein said selected gaming machine comprises a slot machine and wherein said outcome includes a reel position.

54. (Previously Presented) The remote computer of claim 52 wherein said operation of receiving information includes receiving information selecting at least two of said plurality of local gaming machines for remote play.

55. (Previously Presented) The remote computer of claim 52 wherein said operation of receiving information includes receiving a gaming machine identifier.

56. (Previously Presented) The remote computer of claim 52 wherein said operation of receiving information includes receiving a gaming machine type.

57. (Previously Presented) The remote computer of claim 52 wherein said operation of receiving information includes receiving player preferences.

58. (Previously Presented) The remote computer of claim 52 wherein said selected gaming machine comprises a video poker machine including a display for displaying a poker hand.

59. (Previously Presented) The remote computer of claim 52 wherein said outcome comprises data identifying the value of said payout; and further comprising the operation of using said payout data to simulate a display of said outcome at said remote location.

60. (Previously Presented) The remote computer of claim 52 wherein said outcome comprises information identifying a reel position of said selected gaming machine; and further comprising the operation of using said outcome data to display said reel position at said remote location.

61. (Previously Presented) The remote computer of claim 52 further including the operations of: receiving a player identifier; and transmitting said player identifier for identification of said player.

62. (Currently Amended) A remote computer located outside a gaming establishment, said gaming establishment having a plurality of physical gaming machines linked by a gaming server, said remote computer connected to a gaming site through a global computing network served by said gaming server comprising:

means for receiving information identifying a plurality of ~~local~~-physical gaming machines each engaged in play by a player within said gaming establishment;

means for transmitting data from said remote computer for selecting at least one of said plurality of ~~local~~-physical gaming machines for information transfer;

means for receiving a text or graphical outcome resulting from a play of said selected ~~local~~ physical gaming machines; and

for generating a payout if said outcome meets predetermined criteria.

AF  
Zhu

Customer No. 30223

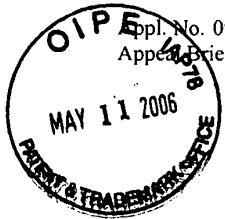

Appl. No. 09/688501  
Appeal Brief

PATENT

IN THE UNITED STATES PATENT AND TRADEMARK OFFICE

Appl. No. : 09/688501  
 Applicant : Shridhar P. Joshi  
 Filed : October 16, 2000  
 Title : METHOD OF TRANSFERRING GAMING DATA ON A GLOBAL  
 COMPUTER NETWORK  
 Conf. No. : 3225  
 Art Unit : 3714  
 Examiner : Alex P. Rada  
 Docket No. : 47079-00077

APPEAL BRIEF PURSUANT TO 37 C.F.R. § 41.37

**MAIL STOP APPEAL BRIEF—PATENTS**

U.S. Patent and Trademark Office  
 Commissioner for Patents  
 P.O. Box 1450  
 Alexandria, VA 22313-1450

Dear Commissioner:

This Appeal Brief is filed pursuant to Applicant's appeal to the Board of Patent Appeals and Interferences from the final rejection of claims 37-62. The due date for this Appeal Brief is May 6, 2006.

05/12/2006 TBESHAKI 00000022 100447 09688501  
 01 FC:1402 500.00 DA

**TABLE OF CONTENTS**

I. Real Party in Interest.....3

II. Related Appeals and Interferences.....4

III. Status of Claims .....5

IV. Status of Amendments.....6

V. Summary of Claimed Subject Matter.....7

    A. Summary of Invention.....7

    B. Summary of Independent Claim 37 .....7

    C. Summary of Independent Claim 38 .....8

    D. Summary of Independent Claim 39 .....8

    E. Summary of Independent Claim 52 .....8

    F. Summary of Independent Claim 62 .....9

    G. Summary of Dependent Claims 46, 47, 50, 56, and 57 .....10

VI. Grounds of Rejection to be Reviewed on Appeal.....11

VII. Argument.....12

    A. The Law of Obviousness.....12

    B. Rejection of Claims 37 and 38 under 35 U.S.C. § 103 .....13

    C. Rejection of Claims 39, 52, and 62 under 35 U.S.C. § 103 .....16

    D. Rejection of Claims 46, 47, 50, 56, and 57 under 35 U.S.C. § 103 .....18

VIII. Claims Appendix.....20

IX. Evidence Appendix .....21

X. Related Proceedings Appendix .....22



**I. REAL PARTY IN INTEREST**

The real party in interest is WMS Gaming Inc., assignee of the above-referenced application, having a place of business at 3401 North California Avenue, Chicago, Illinois 60618.

## **II. RELATED APPEALS AND INTERFERENCES**

There are no other appeals or interferences that will directly affect or be directly affected by or have a bearing on the Board of Patent Appeals and Interferences in the present appeal.

### **III. STATUS OF CLAIMS**

Currently pending 37-62 have been rejected and are the claims being appealed. Claims 1-36 have been cancelled. No claims have been allowed.

#### **IV. STATUS OF AMENDMENTS**

No amendments were filed after the final rejection. All previous claim amendments have been entered.

## **V. SUMMARY OF CLAIMED SUBJECT MATTER**

### **A. Summary of Invention**

Applicants' invention is Generally directed to a remote gaming method in which players located outside a casino or gaming establishment may play gaming machines located inside the gaming establishment. *See, e.g., p. 3, lines 5-14.* As seen in FIG. 1, the remotely located players may access the gaming machines (160, 161, 162) by connecting to a casino web site (130) over the Internet (120) via a remote terminal (110). *See, e.g., p. 7, line 21 to p. 8, line 6.* The casino web site (130) receives randomly-generated outcome data from the gaming machines (160, 161, 162) through a casino server (140) and provides that outcome data to the remote terminal (110). *See, e.g., p. 13, line 3 to p. 14, line 14.* Each gaming machine (160, 161, 162) has uniquely identifying characteristics that allow the casino server (140) to distinguish data from that gaming machine (160, 161, 162) from other gaming machines. *See, e.g., p. 8, lines 23-25.*

To play, the remotely located players simply sign in to the casino web site (130) through the remote terminal (110) and specify one or more player preferences. *See, e.g., p. 13, lines 3-12.* The player preferences are then transmitted from the casino web site (130) to the casino server (140), which subsequently matches the player preferences to one or more wagering games/gaming machines (160, 161, 162) in the gaming establishment. *See, e.g., p. 13, lines 19-29.*

### **B. Summary of Independent Claim 37**

Independent claim 37 is directed to a method of accessing a gaming site on a global computer network using a remote terminal. The method comprises, among other things, selecting a game of chance from a plurality of gaming machines located at a gaming establishment for remote play. The method further comprises placing a wager for playing the selected game via the remote terminal and receiving randomly-generated text or graphical outcome data at the remote terminal for the selected game. The outcome data is generated by one of the plurality of gaming machines at the gaming establishment and relayed to the gaming site through a gaming server.

**C. Summary of Independent Claim 38**

Independent claim 38 is directed to a remote gaming method that uses a gaming server a remote terminal, and a gaming site on a global computer network. The method comprises, among other things, randomly generating outcome data at one of a plurality of gaming machines communicatively coupled to the gaming server. The outcome data is generated for a game selected according to game selection information, the plurality of gaming machines being located at the gaming establishment. The method further comprises receiving the outcome data at the gaming server and transmitting the outcome data from the gaming server to the gaming site for display to the player on the remote terminal in text or graphical form.

The method of claim 38 differs from claim 37 in that it is from the perspective of the gaming establishment, whereas the method of claim 37 is from the perspective of the remote terminal.

**D. Summary of Independent Claim 39**

Independent claim 39 is directed to a method for playing a gaming machine located inside a gaming establishment from a remote terminal located outside the gaming establishment. The method comprises, among other things, establishing a communication link between the remote terminal and a gaming site on a global computer network. The gaming site is in communication with a gaming server for collecting outcome data from gaming machines located inside the gaming establishment. The method further comprises selecting a gaming machine at the gaming establishment using the remote terminal and making a wager to play the selected gaming machine. Outcome data, including game outcome, is received at the remote terminal resulting from a play of the gaming machine, and a payout is generated if the game outcome meets predetermined criteria.

The method of claim 39 differs from claims 37 and 38 in that it selects a particular gaming machine for remote play instead of a wagering game.

**E. Summary of Independent Claim 52**

Independent claim 52 is directed to a remote computer for the remote play of a local gaming machine located within a gaming establishment, the remote computer being located

outside the gaming establishment. The remote computer comprises a microprocessor, memory connected to the microprocessor and including instructions for controlling the microprocessor. The microprocessor is operative with the instructions in the memory to receive information identifying a plurality of local gaming machines located within the gaming establishment from a gaming server and to transmit data selecting at least one of the plurality of local gaming machines for remote play. The microprocessor is further operative with the instructions in the memory to receive a text or graphical outcome resulting from a local play of each the selected local gaming machine and generate a payout if the outcome meets predetermined criteria.

Claim 52 differs from the previous independent claims in that it is an apparatus claim, not a method claim.

#### **F. Summary of Independent Claim 62**

Independent claim 62 is also directed to a remote computer located outside a gaming establishment. The remote computer comprises means for receiving information identifying a plurality of local gaming machines each engaged in play within the gaming establishment and means for transmitting data from the remote computer for selecting at least one of the plurality of local gaming machines for information transfer. The remote computer further comprises means for receiving a text or graphical outcome resulting from a play of the selected local gaming machines and for generating a payout if the outcome meets predetermined criteria.

Claim 62 differs from claim 52 in that it is written in means-plus-function language and therefore, in accordance with 35 U.S.C. §112, sixth paragraph, must be interpreted to cover only the structures (and equivalents thereof) disclosed in the specification for performing the recited functions. For example, with respect to the “means for receiving information,” the recited function is receiving information identifying a plurality of local gaming machines, and the structure disclosed for performing that function is the remote terminal (110) and associated selection buttons, mouse (112), and/or keyboard (114). *See, e.g., p. 11, lines 27-30.* With respect to the “means for transmitting data,” the recited function is transmitting data from the remote computer for selecting at least one of the plurality of local gaming machines, and the structure disclosed for performing that function is the casino web site (130). *See, e.g., p. 13, lines 13-18.* As for the “means for receiving a text or graphical outcome” and “for generating a

payout,” the recited functions are receiving a text or graphical outcome resulting from a play of the selected local gaming machines, and generating a payout if the outcome meets predetermined criteria, respectively. The disclosed structure for performing the recited functions is the casino server (140). *See, e.g., p. 14, lines 5-14; p. 15, lines 4-14.*

**G. Summary of Dependent Claims 46, 47, 50, 56, and 57**

Dependent claims 46 and 56 relate to an aspect of the invention where the outcome data includes a gaming machine type.

Claims 47 and 57 relate to an aspect of the invention where the outcome data includes player preferences.

Claim 50 relates to an aspect of the invention where the game outcome results from the gaming server initiating game play on the selected gaming machine.

As discussed below, each of these dependent claims includes subject matter that is not taught or suggested in the prior art.



**VI. GROUNDS OF REJECTION TO BE REVIEWED ON APPEAL**

Whether claims 37-38 are unpatentable under 35 U.S.C. § 103(a) over U.S. Patent Nos. 6,409,602 to Wiltshire et al. (“Wiltshire”) and 6,580,710 to Paravia et al. (“Paravia”).

Whether claims 39-62 are unpatentable under 35 U.S.C. § 103(a) over Wiltshire and U.S. Patent No. 6,001,016 to Walker (“Walker”).

## VII. ARGUMENT

### A. The Law of Obviousness

Obviousness requires that all the limitations of a claim must be taught or suggested by the combined prior art references. M.P.E.P. § 2143.03 (citing *In re Royka*, 490 F.2d 981, 985, 180 U.S.P.Q. 580, 583 (C.C.P.A. 1974)). A *prima facie* case of obviousness requires three basic criteria:

First, there must be some suggestion or motivation, either in the references themselves or in the knowledge generally available to one of ordinary skill in the art, to modify the reference or to combine reference teachings. Second, there must be a reasonable expectation of success. Finally, the prior art reference (or references when combined) must teach or suggest all the claim limitations. The teaching or suggestion to make the claimed combination and the reasonable expectation of success must both be found in the prior art, not in applicant's disclosure.

M.P.E.P. § 2143 (citing *In re Vaeck*, 947 F.2d 488, 493, 20 U.S.P.Q.2d 1438, 1442 (Fed. Cir. 1991)).

Although a prior art reference may be modified to meet the claimed limitation, the resultant modified reference is not obvious unless the prior art also suggests or motivates the desirability of the modification. *In re Mills*, 916 F.2d 680, 682, 16 U.S.P.Q.2d 1430, 1432 (Fed. Cir. 1990) (citing *In re Gordon*, 733 F.2d 900, 902, 221 U.S.P.Q. 1125, 1127 (Fed. Cir. 1984)). Obviousness cannot "be established using hindsight or in view of the teachings or suggestions of the invention." *Ex parte Maguire*, 2002 WL 1801466, \*4 (Bd. Pat. App. & Inter. 2002) (Appendix F) (quoting *Para-Ordnance Mfg. Inc. v. SGS Importers Int'l Inc.*, 73 F.3d 1085, 1087, 37 U.S.P.Q.2d 1237, 1239 (Fed. Cir. 1995), *cert. denied*, 519 U.S. 822 (1996)). Further, the proposed modification cannot render the prior art "unsatisfactory for its intended purpose" nor can it "change the principle of operation" of a reference. M.P.E.P. § 2143.01 (citing *In re Gordon*, 733 F.2d at 902, 221 U.S.P.Q. at 1127 and *In re Ratti*, 270 F.2d 810, 813, 123 U.S.P.Q. 349, 352 (C.C.P.A. 1959)).

Obviousness also requires that a reference be considered as a whole, including those portions that teach away from the Applicant's claimed invention. *See W.L. Gore & Assoc., Inc. v. Garlock, Inc.*, 721 F.3d 1540, 1550-51, 220 U.S.P.Q. 303, 311 (Fed. Cir. 1983) ("[T]he totality

of a reference's teaching must be considered."); *see also* M.P.E.P. § 2141.02 (stating that prior art must be considered in its entirety including disclosures that teach away from the claims). Indicia of teaching away in a reference gives insight into the question of obviousness. *Monarch Knitting Mach. Corp. v. Sulzer Morat GMBH*, 139 F.3d 877, 885, 45 U.S.P.Q.2d 1977, 1984 (Fed. Cir. 1998). A prior art reference may be considered to teach away when "a person of ordinary skill, upon reading the reference, would be discouraged from following the path set out in the reference, or would be led in a direction divergent from the path that was taken by the applicant." *Monarch Knitting*, 139 F.3d at 885, 45 U.S.P.Q.2d at 1984 (quoting *In re Gurley*, 27 F.3d 551, 553, 31 U.S.P.Q. 1130, 1131 (Fed. Cir. 1994)).

**B. Rejection of Claims 37 and 38 under 35 U.S.C. § 103**

**1. Wiltshire and Paravia do not teach or suggest remote play of a game of chance from a plurality of "gaming machines" in a gaming establishment.**

A *prima facie* case of obviousness has not been established for claims 37 and 38 because Wiltshire and Paravia fail to teach or suggest remote play of a game of chance from a plurality of "gaming machines" in a gaming establishment. Such remote play allows players to play the game of chance without having to be present at the gaming establishment.

There are inherent advantages to being able to play a game of chance from an actual, real-life gaming machine in a gaming establishment without having to be present at the gaming establishment. For example, players may have a preference for the games of chance from gaming machines at a particular gaming establishment. Possibly, the players were very "lucky" during their last visit to the gaming establishment. The invention recited in claims 37 and 38 allows the players to play a game of chance from the very same gaming machines without having to be present at the gaming establishment.

Casino operators also benefit. As stated in the specification, resources are required to operate the gaming machines, including capital investment in each gaming machine, electricity to run the gaming machines, and maintenance of wear on the gaming machines resulting from game play. *See, e.g., p. 15, line 31 to p. 6, line 2.* By making existing gaming machines at the gaming establishment available to players located outside the casino, the casino operators can increase revenue without investing in new gaming machines. Moreover, the existing gaming machines

have already completed regulatory review and would not need to do so again for remote play, thus providing further cost savings to the casino operators.

None of the above benefits are available in Wiltshire. This is because Wiltshire does not teach or suggest remote play of a game of chance from a plurality of gaming machines in a gaming establishment. In contrast, Wiltshire teaches a computer gaming system involving a host/server computer connected to a plurality of remote client/terminal computers. *See, e.g., col. 3, lines 61-66.* One or more game programs are executed on the server/host computer for playing casino games. *See, e.g., col. 4, lines 35-38; col. 5, lines 45-50.* The one or more game programs generate casino game images that are then transferred from the server/host computer to the client/terminal computers. *See, e.g., col. 7, lines 18-22.* But while the computer gaming system of Wiltshire allows remote play of a game of chance, **the game of chance comes from the server/host computer, not gaming machines in a gaming establishment.**

Paravia also fails to teach or suggest remote play of a game of chance from a plurality of gaming machines in a gaming establishment. To the contrary, Paravia merely teaches a system for allowing players to place wagers on various sporting events over the Internet. *See, e.g., col. 9, lines 62-65.* Examples of such sporting events include basketball games, auto-racing events, to boating events, political polling results, jury trials, impeachment hearings, and the like. *See, e.g., col. 9, lines 25-42.* Such events involve a certain level of skill (i.e., the outcomes are not purely random because the player's knowledge influences their wager) and are therefore not considered by persons having ordinary skill in the art to be games of chance. Nowhere does Paravia teach or suggest remote play of games of chance, much less games of chance from gaming machines in a gaming establishment.

**2. Wiltshire's "host/server computer" executing casino software is not functionally equivalent to "gaming machines" in a gaming establishment.**

The Examiner attempts to gloss over the above differences between Wiltshire's host/server computer executing casino software and the claimed games of chance on a plurality of gaming machines in a gaming establishment by stating that the two are "functionally equivalent." *See, e.g., Office Action mailed November 2, 2005, p. 9, lines 10-19; Advisory Action Mailed January 25, 2006, p. 2, lines 9-17.* However, when viewed from a sufficiently broad

perspective, almost anything may be functionally equivalent to almost anything else. For example, an airplane is functionally equivalent to a hot air balloon in that both are machines capable of flight, but the two function on entirely different principles. Therefore, to establish a *prima facie* case of functional equivalency, the Examiner must comply with M.P.E.P. § 2144.06, reproduced in part below:

In order to rely on equivalence as a rationale supporting an obviousness rejection, **the equivalency must be recognized in the prior art**, and cannot be based on applicant's disclosure or the mere fact that the components at issue are functional or mechanical equivalents. *In re Ruff*, 256 F.2d 590, 118 U.S.P.Q. 340 (C.C.P.A. 1958).

(Emphasis added.)

In the present case, nothing in Wiltshire suggests that a host/server computer executing casino software is recognized in the prior art as functionally equivalent to games of chance on a plurality of gaming machines in a gaming establishment. Nor has the Examiner produced any other prior art evidence that a person of ordinary skill in the art recognizes such a functional equivalency. **Without this showing, Applicant respectfully submits there can be no basis for a rejection under functional equivalency.**

Moreover, the invention recited in claims 37 and 38 operates on entirely different principles than the remote gaming system of Wiltshire. For example, the claimed invention is considered to be a "distributed" system insofar as each gaming machine generates its own outcome data. Therefore, each gaming machine must be uniquely identifiable from other gaming machines in order to avoid mixing the outcome data. *See, e.g., p. 8, lines 23-25*. The remote gaming system of Wiltshire, on the other hand, is considered to be a "centralized" system insofar as all outcome data is generated by the host/server computer. As such, an entirely different set of protocols is needed, one that does not include a unique identification for the host/server computer.

### 3. Summary of Arguments for claims 37 and 38.

Based on the foregoing, the Examiner's position fails because (i) Wiltshire and Paravia do not teach or suggest remote play of a game of chance from a plurality of "gaming machines" in a gaming establishment, and (ii) Wiltshire's "host/server computer" executing casino software

is not functionally equivalent to “gaming machines” in a gaming establishment. Accordingly, Applicant respectfully request withdrawal of the rejection of claims 37 and 38 under 35 U.S.C. § 103.

**C. Rejection of Claims 39, 52, and 62 under 35 U.S.C. § 103**

**1. Wiltshire and Walker fail to teach or suggest selecting a gaming machine within a gaming establishment from “a remote terminal located outside the gaming establishment.”**

A *prima facie* case of obviousness has not been established for claims 39, 52, and 62 for the reasons stated above with respect to claims 37 and 39, and also because Wiltshire and Walker fail to teach or suggest “selecting a gaming machine” in a gaming establishment from a remote terminal located outside the gaming establishment. Such an arrangement is particularly useful where a player located outside the gaming establishment has a preference for one or more of the gaming machines inside the gaming establishment, possibly because the player developed an emotional attachment to the gaming machine on a previous visit to the gaming establishment. For example, the gaming establishment may have 20 slot machines on its premises, and the player may have developed a preference for a particular one of these slot machines during his/her previous visit. The invention claimed in claims 39, 52, and 62 allows the player to select that particular slot machine for remote play after he/she leaves the gaming establishment.

As explained above, Wiltshire teaches a computer gaming system involving a host/server computer connected to a plurality of remote client/terminal computers. *See, e.g., col. 3, lines 61-66.* One or more game programs are executed on the server/host computer for playing casino games. *See, e.g., col. 4, lines 35-38; col. 5, lines 45-50.* The one or more game programs generate casino game images that are then transferred from the server/host computer to the client/terminal computers. *See, e.g., col. 7, lines 18-22.* The images illustrate various casino games supported by the computer gaming system. *See, e.g., col. 8, lines 49-51.*

Each of the available casino games is represented by an image of a “virtual button” that the player may actually play that casino game. *See, e.g., col. 8, lines 51-55.* But while the computer gaming system of Wiltshire allows players to select a casino game for remote play, **nowhere does Wiltshire even teach or suggest selecting a gaming machine**, much less selecting a gaming machine within a gaming establishment from a remote terminal located

outside the gaming establishment. Stated another way, Wiltshire does not distinguish between the individual gaming machines, such as slot machine A versus slot machine B (which may be the same type of slot machine), only the types of casino games, such as blackjack versus poker.

Walker also fails to teach or suggest selecting a gaming machine within the gaming establishment from a remote terminal located outside the gaming establishment. In Walker, multiple slot machines are in communication with a slot network server that, in turn, is in communication with a plurality of remote wagering terminals. *See, e.g., col. 3, line 60 to col. 4, line 2.* Each slot machine communicates outcome data to the slot network server, and the slot network server relays the outcome data to the remote wagering terminals. *See, e.g., col. 10, lines 31-35.*

However, Walker appears to teach that **the remote wagering terminal is located right there on the premises of the gaming establishment.** For example, Walker teaches that “each” remote wagering terminal has a hopper for dispensing coins. *See, e.g., col. 7, lines 54-56.* Such a hopper would need to be maintained and refilled from time to time with an appropriate amount of coins. It would be extremely difficult to effect such maintenance unless the remote wagering terminal was located right there on the premises. This position is further supported by the statement in Walker that the player will be provided with a “map of all slots machines.” *See, e.g., col. 9, lines 36-38.* Such a map would only be useful if the player (hence, the remote wagering terminal) was right there on the premises. In addition, Walker teaches that the player is able to enter (on the remote wagering terminal) the ID number of each slot machine because each slot machine prominently displays an ID tag. *See e.g., col. 9, lines 33-38.* Clearly, the player (hence, the remote wagering terminal) must be on the premises with the slot machines in order to be able to see the ID tags. Thus, Walker fails to teach or suggest selecting a gaming machine within a gaming establishment from a remote terminal located outside the gaming establishment.

**2. Wiltshire and Walker fail to teach or suggest “relaying outcome data” through a gaming site.**

Wiltshire fails to teach or suggest relaying outcome data through a gaming site. The Examiner contends that the “website” in FIG. 3 of Wiltshire is a gaming site. *Office Action mailed November 2, 2005, p. 8, lines 6-11.* However, Wiltshire teaches very clearly that the

website is merely a software download site for downloading the client/terminal software. For example, Wiltshire states that once the software is installed on the client/terminal computer, the client/terminal computer connects to the host/server computer, **not to the website**. See, e.g., col. 8, lines 27-31. Nowhere does Wiltshire teach or suggest relaying outcome data through the website. Indeed, after its mention in col. 8, lines 27-31, the website is never referenced again throughout the remainder of Wiltshire.

Walker also fails to teach or suggest relaying outcome data through a gaming site. To the contrary, as can be seen in FIG. 1, Walker teaches that the remote wagering terminals are connected directly to the slot network server via a local area network. See, e.g., col. 4, lines 2-5. Indeed, **a full text search of Walker for the term “website” or even just “site” returned zero hits.**

### **3. Summary of Arguments for claims 39, 52, and 62.**

Based on the foregoing, the Examiner’s position fails because (i) Wiltshire and Walker fail to teach or suggest selecting a gaming machine within a gaming establishment from a remote terminal located outside the gaming establishment, and (ii) Wiltshire and Walker fail to teach or suggest “relaying outcome data” through a gaming site. Accordingly, Applicant respectfully request withdrawal of the rejection of claims 39, 52, and 62 under 35 U.S.C. §103.

#### **D. Rejection of Claims 46, 47, 50, 56, and 57 under 35 U.S.C. § 103**

##### **1. Walker fails to teach or suggest outcome data that includes a “gaming machine type,” as required by claims 46 and 56.**

A *prima facie* case of obviousness has not been established against dependent claims 46 and 56 because Walker fails to teach or suggest outcome data that includes a gaming machine type. For example, Walker teaches that the outcome data may include whether the player has won or lost, the amount won (if any), the amount of lost (if any), and the visual representation of the outcome of a play on the slot machine, such as the positions of the reels. See, e.g., col. 4 lines 13-17. **However, nowhere does Walker teach or suggest that the outcome data may include a gaming machine type.**



2. **Walker fails to teach or suggest outcome data that includes “player preferences,” as required by claims 47 and 57.**

A *prima facie* case of obviousness has also not been established against dependent claims 47 and 57 because Walker fails to teach or suggest outcome data that includes player preferences. As mentioned above, Walker teaches outcome data that may include whether the player has won or lost, the amount won (if any), the amount lost (if any), and the visual representation of the outcome of a play on the slot machine, such as the positions of the reels. *See, e.g., col. 4 lines 13-17. However, nowhere does Walker teach or suggest that the outcome data may include player preferences.*

3. **Walker fails to teach or suggest a gaming server initiating game play, as required by claims 50.**

Finally, a *prima facie* case of obviousness has not been established against dependent claim 50 because Walker fails to teach or suggest the gaming server initiating game play on the selected gaming machine. For example, Walker teaches that the slot network server selects slot machines that are currently being play by players physically present at the slot machines for remote play in order to obtain live outcome data. *See, e.g., col. 10, lines 16-19.* Therefore, the players physically present at the slot machines are the ones who initiate game play, **not the slot network server**. The slot network server simply taps into the live outcome data from the slot machines and relays that data to the remote wagering terminals.

**VIII. CLAIMS APPENDIX**

A copy of the currently pending claims is attached as Appendix A.

**IX. EVIDENCE APPENDIX**

Copies of the Wiltshire, Paravia, and Walker patents are attached as Appendices B, C and D, respectively. A copy of an Office Action mailed November 2, 2005, finally rejecting the claims is attached as Appendix E. A copy of an Advisory Action mailed January 25, 2006, maintaining the rejections is attached as Appendix F.

**X. RELATED PROCEEDINGS APPENDIX**

None.

**CONCLUSION**

For at least the foregoing reasons, the final rejection of all the appealed claims should be reversed.

A check in the amount of \$500.00 is enclosed herewith as required by 37 C.F.R. § 41.20(b)(2) for filing this Appeal Brief. The Commissioner is authorized to charge any additional fees inadvertently omitted that may be required (except the issue fee) now or during the pendency of this application to JENKENS & GILCHRIST, P.C. Deposit Account No. 10-0447 (47079-00077).

**The PTO did not receive the following listed item(s) a check for \$ 500-**

Date: May 8, 2006

Respectfully submitted,

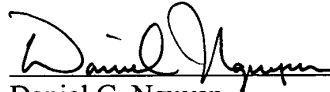

\_\_\_\_\_  
Daniel G. Nguyen  
Reg. No. For 2,933  
JENKENS & GILCHRIST, P.C.  
225 West Washington Street  
Suite 2600  
Chicago, IL 60606-3418  
(713) 951-3354  
(713) 951-3314 (fax)  
ATTORNEYS FOR APPLICANTS

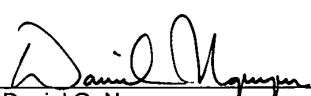

<b>TRANSMITTAL OF APPEAL BRIEF</b>			Docket No. 47079-00077USPT
In re Application of: Shridhar P. Joshi			
Application No. 09/688501	Filing Date October 16, 2000	Examiner A. P. Rada	Group Art Unit 3714
Invention: METHOD OF TRANSFERRING GAMING DATA ON A GLOBAL COMPUTER NETWORK			
<b><u>TO THE COMMISSIONER OF PATENTS:</u></b>			
Transmitted herewith is the Appeal Brief in this application, with respect to the Notice of Appeal filed: <u>March 6, 2006</u> .			
The fee for filing this Appeal Brief is <u>\$ 500.00</u> .			
<input checked="" type="checkbox"/> Large Entity <input type="checkbox"/> Small Entity			
<input type="checkbox"/> A petition for extension of time is also enclosed.			
The fee for the extension of time is _____ .			
<input type="checkbox"/> A check in the amount of _____ is enclosed.			
<input checked="" type="checkbox"/> Charge the amount of the fee to Deposit Account No. <u>10-0447</u> . This sheet is submitted in duplicate.			
<input type="checkbox"/> Payment by credit card. Form PTO-2038 is attached.			
<input checked="" type="checkbox"/> The Director is hereby authorized to charge any additional fees that may be required or credit any overpayment to Deposit Account No. <u>10-0447</u> . This sheet is submitted in duplicate.			
 Daniel G. Nguyen Attorney Reg. No. : 42,933 JENKENS & GILCHRIST, A PROFESSIONAL CORPORATION 225 W. Washington, Ste. 2600 Chicago, Illinois 60606-3418 (713) 951-3354		Dated: <u>May 8, 2006</u>	

**APPENDIX A – CLAIMS ON APPEAL**

Claims 1-36. (Cancelled)

37. (Previously Presented) A remote gaming method comprising:
- accessing, via a remote terminal, a gaming site on a global computer network connected to said remote terminal;
  - providing, via said remote terminal, personal identification information to said gaming site;
  - selecting, via said remote terminal, a game of chance from a plurality of gaming machines located at a gaming establishment for remote play, said remote terminal being located outside said gaming establishment;
  - placing, via said remote terminal, a wager for playing said selected game; and
  - receiving randomly-generated text or graphical outcome data at said remote terminal for said selected game, said outcome data being generated by one of said plurality of gaming machines at said gaming establishment and relayed to said gaming site through a gaming server connected to said gaming site.

38. (Previously Presented) A remote gaming method using a gaming server, a remote terminal, and a gaming site on a global computer network, said gaming server being located at a gaming establishment, said remote terminal being located outside said gaming establishment, said gaming site being provided on said global computer network, the method comprising:

receiving, at said gaming server, personal identification information, game selection information, and wager information from a player accessing said gaming site via said remote terminal, said remote terminal being connected to said global computer network;

randomly generating outcome data at one of a plurality of gaming machines communicatively coupled to said gaming server, said outcome data being generated for a game selected according to said game selection information, said plurality of gaming machines being located at said gaming establishment;

receiving said outcome data at said gaming server; and

transmitting said outcome data from said gaming server to said gaming site for display to said player on said remote terminal in text or graphical form.



39. (Previously Presented) A method for playing a gaming machine located inside a gaming establishment from a remote terminal located outside the gaming establishment comprising:

establishing a communication link between said remote terminal and a gaming site on a

global computer network, said gaming site in communication with a gaming

server for collecting outcome data from gaming machines located inside the

gaming establishment;

selecting a gaming machine at said gaming establishment using said remote terminal;

making a wager to play the selected gaming machine;

receiving outcome data, including game outcome, at said remote terminal resulting from a

play of said gaming machine; and

generating a payout if said game outcome meets predetermined criteria.

40. (Previously Presented) The method of claim 39 wherein said outcome data comprises information identifying the value of said payout; and further comprising the step of using said payout information to simulate a display of said game outcome at said remote location.

41. (Previously Presented) The method of claim 39 further comprising using said outcome data to simulate a display of said game outcome on said remote terminal.

42. (Previously Presented) The method of claim 39, wherein said selected gaming machine comprises a slot machine and wherein said game outcome data includes a reel position.

43. (Previously Presented) The method of claim 39 wherein said selected gaming machine comprises a video poker machine including a display for displaying a poker hand.

44. (Previously Presented) The method of claim 39 wherein said step of receiving outcome data includes receiving outcome data from a plurality of gaming machines for remote play.
45. (Previously Presented) The method of claim 44 wherein said step of receiving outcome data includes receiving a gaming machine identifier.
46. (Previously Presented) The method of claim 44 wherein said step of receiving outcome data includes receiving a gaming machine type.
47. (Previously Presented) The method of claim 44 wherein said step of receiving outcome data includes receiving player preferences.
48. (Previously Presented) The method of claim 39 wherein said selected gaming machine comprises a slot machine and wherein said game outcome comprises information identifying a reel position of said gaming machine; and further comprising the step of using said outcome information to display said reel position on said remote terminal.
49. (Previously Presented) The method of claim 39 and further including the steps of receiving a player identifier; and transmitting said player identifier for identification of said player.
50. (Previously Presented) The method of claim 39 wherein said game outcome results from the server initiating game play on the selected gaming machine.
51. (Previously Presented) The method of claim 39 wherein said game outcome results from the manual game play on the selected gaming machine.

52. (Previously Presented) A remote computer for the remote play of a local gaming machine located within a gaming establishment and connected to a gaming server, the remote computer being located outside said gaming establishment, said remote computer connected to a gaming site through a global computing network served by said gaming server, said remote computer comprising:

a microprocessor;

memory connected to said microprocessor and including instructions for controlling said microprocessor; and

said microprocessor being operative with said instructions in said memory to:

receive information identifying a plurality of local gaming machines located within said gaming establishment from a gaming server;

transmit data selecting of at least one said plurality of local gaming machines for remote play;

receive a text or graphical outcome resulting from a local play of each said selected local gaming machine; and

generate a payout if said outcome meets predetermined criteria.

53. (Previously Presented) The remote computer of claim 52 wherein said selected gaming machine comprises a slot machine and wherein said outcome includes a reel position.

54. (Previously Presented) The remote computer of claim 52 wherein said operation of receiving information includes receiving information selecting at least two of said plurality of local gaming machines for remote play.

55. (Previously Presented) The remote computer of claim 52 wherein said operation of receiving information includes receiving a gaming machine identifier.
56. (Previously Presented) The remote computer of claim 52 wherein said operation of receiving information includes receiving a gaming machine type.
57. (Previously Presented) The remote computer of claim 52 wherein said operation of receiving information includes receiving player preferences.
58. (Previously Presented) The remote computer of claim 52 wherein said selected gaming machine comprises a video poker machine including a display for displaying a poker hand.
59. (Previously Presented) The remote computer of claim 52 wherein said outcome comprises data identifying the value of said payout; and further comprising the operation of using said payout data to simulate a display of said outcome at said remote location.
60. (Previously Presented) The remote computer of claim 52 wherein said outcome comprises information identifying a reel position of said selected gaming machine; and further comprising the operation of using said outcome data to display said reel position at said remote location.
61. (Previously Presented) The remote computer of claim 52 further including the operations of: receiving a player identifier; and transmitting said player identifier for identification of said player.

62. (Previously Presented) A remote computer located outside a gaming establishment, said gaming establishment having a plurality of gaming machines linked by a gaming server, said remote computer connected to a gaming site through a global computing network served by said gaming server comprising:

means for receiving information identifying a plurality of local gaming machines each engaged in play within said gaming establishment;

means for transmitting data from said remote computer for selecting at least one of said plurality of local gaming machines for information transfer;

means for receiving a text or graphical outcome resulting from a play of said selected local gaming machines; and

for generating a payout if said outcome meets predetermined criteria.



UNITED STATES PATENT AND TRADEMARK OFFICE

UNITED STATES DEPARTMENT OF COMMERCE  
United States Patent and Trademark Office  
Address: COMMISSIONER FOR PATENTS  
P.O. Box 1450  
Alexandria, Virginia 22313-1450  
www.uspto.gov

APPLICATION NO.	FILING DATE	FIRST NAMED INVENTOR	ATTORNEY DOCKET NO.	CONFIRMATION NO.
09/688,501	10/16/2000	Shridhar P. Joshi	47079-00077	3225

30223 7590 11/02/2005  
JENKENS & GILCHRIST, P.C.  
225 WEST WASHINGTON  
SUITE 2600  
CHICAGO, IL 60606

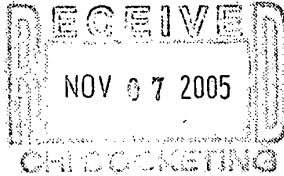

EXAMINER

RADA, ALEX P

ART UNIT PAPER NUMBER

3713

DATE MAILED: 11/02/2005

Please find below and/or attached an Office communication concerning this application or proceeding.

DOCKETED

INIT. JR DATE: 11/3/05  
Resp. to Provoke  
ACTION: \_\_\_\_\_ DATE: 1/2/06  
Final Rej. Due 2/2/06  
Final Rej. Deadline 5/2/06

<b>Office Action Summary</b>	Application No.	Applicant(s)	
	09/688,501	JOSHI, SHRIDHAR P.	
	Examiner	Art Unit	
	Alex P. Rada	3713	

-- The MAILING DATE of this communication appears on the cover sheet with the correspondence address --

**Period for Reply**

A SHORTENED STATUTORY PERIOD FOR REPLY IS SET TO EXPIRE 3 MONTH(S) OR THIRTY (30) DAYS, WHICHEVER IS LONGER, FROM THE MAILING DATE OF THIS COMMUNICATION.

- Extensions of time may be available under the provisions of 37 CFR 1.136(a). In no event, however, may a reply be timely filed after SIX (6) MONTHS from the mailing date of this communication.
- If NO period for reply is specified above, the maximum statutory period will apply and will expire SIX (6) MONTHS from the mailing date of this communication.
- Failure to reply within the set or extended period for reply will, by statute, cause the application to become ABANDONED (35 U.S.C. § 133). Any reply received by the Office later than three months after the mailing date of this communication, even if timely filed, may reduce any earned patent term adjustment. See 37 CFR 1.704(b).

**Status**

- 1)  Responsive to communication(s) filed on 25 July 2005.  
2a)  This action is FINAL.    2b)  This action is non-final.  
3)  Since this application is in condition for allowance except for formal matters, prosecution as to the merits is closed in accordance with the practice under *Ex parte Quayle*, 1935 C.D. 11, 453 O.G. 213.

**Disposition of Claims**

- 4)  Claim(s) 37-62 is/are pending in the application.  
4a) Of the above claim(s) \_\_\_\_\_ is/are withdrawn from consideration.  
5)  Claim(s) \_\_\_\_\_ is/are allowed.  
6)  Claim(s) 37-62 is/are rejected.  
7)  Claim(s) \_\_\_\_\_ is/are objected to.  
8)  Claim(s) \_\_\_\_\_ are subject to restriction and/or election requirement.

**Application Papers**

- 9)  The specification is objected to by the Examiner.  
10)  The drawing(s) filed on \_\_\_\_\_ is/are: a)  accepted or b)  objected to by the Examiner.  
Applicant may not request that any objection to the drawing(s) be held in abeyance. See 37 CFR 1.85(a).  
Replacement drawing sheet(s) including the correction is required if the drawing(s) is objected to. See 37 CFR 1.121(d).  
11)  The oath or declaration is objected to by the Examiner. Note the attached Office Action or form PTO-152.

**Priority under 35 U.S.C. § 119**

- 12)  Acknowledgment is made of a claim for foreign priority under 35 U.S.C. § 119(a)-(d) or (f).  
a)  All    b)  Some \*    c)  None of:  
1.  Certified copies of the priority documents have been received.  
2.  Certified copies of the priority documents have been received in Application No. \_\_\_\_\_.  
3.  Copies of the certified copies of the priority documents have been received in this National Stage application from the International Bureau (PCT Rule 17.2(a)).

\* See the attached detailed Office action for a list of the certified copies not received.

**Attachment(s)**

- |  |   |
|--|---|
| 1) <input checked="" type="checkbox"/> Notice of References Cited (PTO-892)  | 4) <input type="checkbox"/> Interview Summary (PTO-413)<br>Paper No(s)/Mail Date. _____ |
| 2) <input type="checkbox"/> Notice of Draftsperson's Patent Drawing Review (PTO-948)                                   | 5) <input type="checkbox"/> Notice of Informal Patent Application (PTO-152)             |
| 3) <input type="checkbox"/> Information Disclosure Statement(s) (PTO-1449 or PTO/SB/08)<br>Paper No(s)/Mail Date _____ | 6) <input type="checkbox"/> Other: _____  |

### DETAILED ACTION

In response to the amendment filed July 25, 2005 in which the applicant had previously canceled claims 1-21, and 35-36, cancels claims 22-34, submits arguments and claims 37-62 are pending in this application.

#### *Claim Rejections - 35 USC § 103*

1. The following is a quotation of 35 U.S.C. 103(a) which forms the basis for all obviousness rejections set forth in this Office action:

(a) A patent may not be obtained though the invention is not identically disclosed or described as set forth in section 102 of this title, if the differences between the subject matter sought to be patented and the prior art are such that the subject matter as a whole would have been obvious at the time the invention was made to a person having ordinary skill in the art to which said subject matter pertains. Patentability shall not be negated by the manner in which the invention was made.

2. Claims 37-38 are rejected under 35 U.S.C. 103(a) as being unpatentable over Wiltshire et al. (US 6,409,602) in view of Paravia et al. (US 6,508,710).

3. Wiltshire et al discloses the following:

Accessing via a remote terminal (client/terminal), a gaming site (310 of figure 3) on a global computer network (column 8, lines 15-34) connected to the remote terminal (client/terminal), selecting a game of chance from a plurality of gaming machine located at a gaming establishment for remote play (figures 4b-9D), the remote terminal being located outside the gaming establishment, placing a wager for playing the selected game and receiving randomly-generated text or graphical outcome data at the remote terminal for the selected game the outcome data being generated by one of the plurality of gaming machines at the gaming establishment and relayed to the gaming site through a gaming server connected to the gaming site,



in which the examiner interprets the server/host containing the different programs and data of the different chance game to be a functional equivalent to placing a wager for playing the selected game and receiving randomly-generated text or graphical outcome data at the remote terminal for the selected game the outcome data being generated by one of the plurality of gaming machines at the gaming establishment and relayed to the gaming site through a gaming server connected to the gaming site (column 7, lines 7-56 and figures 2-3) as recited in claims 37-38.

Wiltshire et al does expressly disclose the following:

Providing via the remote terminal, personal identification information to the gaming site as recited in claims 37-38.

Paravia et al teaches the following:

Providing via the remote terminal, personal identification information to the gaming site (column 6, lines 49-55 and item 142 of figure 2) as recited in claims 37-38. By having providing personal identification information to the gaming site, one of ordinary skill in the art would provide a verification and permission to game players that are permitted to play.

Therefore, it would have been obvious to one of ordinary skill in the art at the time of the invention was made to modify Wiltshire et al to include personal identification information to the gaming site as taught Paravia et al to provide a verification and permission to game players that are permitted to play.

4. Claims 39-62 are rejected under 35 U.S.C. 103(a) as being unpatentable over Wiltshire et al. (US 6,409,602) in view of Walker et al. (US 6,001,016).
5. Wiltshire et al discloses the following:

Establishing a communication link between the remote terminal (client/terminal) and a gaming site (310 of figure 3) on a global computer network (column 8, lines 15-34), the gaming site in communication with a gaming server (server/host), selecting a gaming machine (figures 4B-9D) at the gaming establishment using the remote terminal, making a wager to play the selected gaming machine, receiving outcome data, including game outcome at the remote terminal resulting from a play of the gaming machine (figures 4B-9D), and generating a payout if the game outcome meets predetermined criteria (figure 4B, column 7, lines 7-56, and column 8, lines 15-34) as recited in claim 39.

The game outcome resulting from the server initiating game play on the selected gaming machine (column 8, lines 42-65) as recited in claim 50.

The remote computer having a microprocessor, memory connected to the microprocessor and including instructions for controlling the microprocessor, and the microprocessor being operative with the instructions in the memory to receive information identifying a plurality of local gaming machine located within the gaming establishment from a gaming server, receive a text or graphical outcome resulting from a local play of each of the selected gaming machines and generate payout if the outcome meets predetermined criteria (figures 4B-9D, column 6, line 44 – column 7, line 6, column 7, lines 7-56, and column 8, lines 15-34) as recited in claim 52.

The gaming server having means for receiving information identifying a plurality of gaming machines (figures 4B-9D) each engaged in play within the gaming establishment, means for receiving a text or graphical outcome resulting from a play of the selected gaming machines and means for generating a payout if the outcome

meets predetermined criteria (figures 4B-9D, column 6, line 44 – column 7, line 6, column 7, lines 7-56, and column 8, lines 15-34) as recited in claim 62.

Wiltshire et al does not expressly disclose the following:

The gaming server collecting outcome data from the gamine machines located inside the gaming establishment as recited in claims 39, 52 and 62.

The outcome data having information identifying the value of the payout and simulate a display of the game outcome at the remote location as recited in claims 40 and 59.

The outcome data to simulate a display of the game outcome on the remote terminal as recited in claim 41.

The selected gaming machine is a slot machine wherein the outcome data includes reel position as recited in claims 42, 48, 53, and 60.

The selected gaming machine is a video poker machine including a display for displaying a poker hand as recited in claims 43 and 58.

The receiving outcome data includes receiving outcome data from a plurality of gaming machine form remote play as recited in claim 44.

The outcome data includes a gaming machine identifier and gaming machine type as recited in claim 45-46 and 55-56.

The outcome data including receiving player preferences as recited in claims 47 and 57.

A player identifier and transmitting the player identifier for identification of the player as recited in claims 49 and 61.

Walker et al teaches the following:

The gaming server collecting outcome data from the gaming machines located inside the gaming establishment (figure 1) as recited in claims 39, 52 and 62.

The outcome data having information identifying the value of the payout and simulate a display of the game outcome at the remote location (column 5, lines 33-37) as recited in claims 40 and 59.

The outcome data to simulate a display of the game outcome on the remote terminal (column 5, lines 33-37) as recited in claim 41.

The selected gaming machine is a slot machine wherein the outcome data includes reel position (column 5, lines 33-37) as recited in claims 42, 48, 53-54, and 60.

The selected gaming machine is a video poker machine including a display for displaying a poker hand (column 5, lines 33-37) as recited in claims 43 and 58.

The receiving outcome data includes receiving outcome data from a plurality of gaming machine form remote play (column 6, lines 45-56) as recited in claim 44.

The outcome data includes a gaming machine identifier and gaming machine type (figure 5 and column 6, lines 31-44) as recited in claim 45-46 and 55-56.

The outcome data including receiving player preferences (column 6, lines 8-30) as recited in claims 47 and 57.

A player identifier and transmitting the player identifier for identification of the player (column 6, lines 8-30) as recited in claims 49 and 61.

The outcome results from the manual game play on the selected gaming machine (summary) as recited in claim 51. By transmitting data from the gaming machine located in the gaming establishment, one of ordinary skill in the art would

provide a system that does not require human intervention and live video transmission of the game being played.

Therefore, it would have been obvious to one of ordinary skill in the art at the time of the invention was made to modify Wiltshire et al to include the gaming server collecting outcome data from the gaming machines located inside the gaming establishment, the outcome data having information identifying the value of the payout and simulate a display of the game outcome at the remote location, the outcome data to simulate a display of the game outcome on the remote terminal, the selected gaming machine is a slot machine wherein the outcome data includes reel position, the selected gaming machine is a video poker machine including a display for displaying a poker hand, the receiving outcome data includes receiving outcome data from a plurality of gaming machine form remote play, the outcome data includes a gaming machine identifier and gaming machine type, the outcome data including receiving player preferences, and a player identifier and transmitting the player identifier for identification of the player as taught by Walker et al to provide a system that does not require human intervention and live video transmission of the game being played.

#### ***Response to Arguments***

6. Applicant's arguments filed July 25, 2005 have been fully considered but they are not persuasive.

Applicant contends that the Wiltshire reference lacks a gaming site and the "access website" in figure 3 is merely a software download site for downloading the installation software. Once the

Art Unit: 3713

software is installed, the website 310 contribute nothing else to Wiltshire (i.e., provides no gaming data or information to the client/terminal). The Wiltshire reference does not disclose the user of two separate intermediate nodes – a gaming server and a gaming site – between the gaming machines and the remote gaming terminal. The outcome data from the gaming machine passes through two separate intermediate nodes noted before arriving at the gaming terminal.

In response the Wiltshire reference does disclose a gaming site (website) in figure 3, item 310. Wiltshire discloses in col. 8, lines 15-34 that a user accesses a website (gaming site) using a web browser such as Internet Explorer, Netscape Navigator or the like and downloads the program from the website (gaming site). The gaming data or information to the client/terminal is executed from the server/host computer, which updates the state (randomly-generated or graphical outcome data) of the game accordingly (col. 7, lines 7-44 and figure 2).

In response to applicant's argument that the references fail to show certain features of applicant's invention, it is noted that the features upon which applicant relies (i.e., two separate intermediate nodes, a real gaming machine) are not recited in the rejected claim(s). Although the claims are interpreted in light of the specification, limitations from the specification are not read into the claims. See *In re Van Geuns*, 988 F.2d 1181, 26 USPQ2d 1057 (Fed. Cir. 1993). The Wiltshire reference does disclose data passing through two separate intermediate nodes. Figure 1A discloses a first node being the network interface (115), which may access the Internet or a particular website on the Internet and the second node is the server/host (110).

Applicant contends that the host/server computer executing casino game programs is not a functionally equivalent to the gaming machines in a gaming establishment. Any evidence from Wiltshire or any other art recognizes a virtual gaming machine to be functionally equivalent to a gaming machine in a gaming establishment.

In response to applicant's arguments that the host/server computer executing casino game programs is not a functional equivalent to a gaming machine in a gaming establishment, it is noted that a gaming machine at a gaming establishment is just a computer that runs a program either on the gaming machine or communication to a server like in Walker (6,001,016), Karmarkar (6,508,709), and Paravia (6,508,710) to name a few. Since a physical embodiment of various games have been re-implement into microcomputer-based video gaming stations for the last 20 years (Wiltshire-background), it is obvious to a person of ordinary skill in the art would recognize that gaming machine can be re-implemented into a video gaming system, which is nothing more than a cabinet having a monitor, a program either on the gaming machine or communication to a server, and some means of accepting and dispensing wagers. When a gaming machine calculates the game results on the gaming machine at a gaming site, the functional equivalent to that would be a gaming machine running a program and the calculations are carried out on a sever located at a gaming site and routed back to the gaming machine at the gaming site. The only difference is the gaming results are calculated on the server and communicated back to the gaming machine instead of calculating the gaming results at the gaming machine itself. If you take the same computer based video gaming machine and place that video game program on a home PC, the only things that have changed are how the program (results and calculations) are being communicated and how wagers are accepted and payouts awarded. Therefore, a host/server computer executing a casino game program is functionally equivalent to a gaming machine in a gaming establishment.

#### ***Conclusion***

7. **THIS ACTION IS MADE FINAL.** Applicant is reminded of the extension of time policy as set forth in 37 CFR 1.136(a).

A shortened statutory period for reply to this final action is set to expire THREE MONTHS from the mailing date of this action. In the event a first reply is filed within TWO MONTHS of the mailing date of this final action and the advisory action is not mailed until after the end of the THREE-MONTH shortened statutory period, then the shortened statutory period will expire on the date the advisory action is mailed, and any extension fee pursuant to 37 CFR 1.136(a) will be calculated from the mailing date of the advisory action. In no event, however, will the statutory period for reply expire later than SIX MONTHS from the mailing date of this final action.

Any inquiry concerning this communication or earlier communications from the examiner should be directed to Alex P. Rada whose telephone number is 571-272-4452. The examiner can normally be reached on Monday - Friday, 08:00-16:00.

If attempts to reach the examiner by telephone are unsuccessful, the examiner's supervisor, Xuan Thai can be reached on 571-272-7147. The fax phone number for the organization where this application or proceeding is assigned is 571-273-8300.

Information regarding the status of an application may be obtained from the Patent Application Information Retrieval (PAIR) system. Status information for published applications may be obtained from either Private PAIR or Public PAIR. Status information for unpublished applications is available through Private PAIR only. For more information about the PAIR system, see <http://pair-direct.uspto.gov>. Should you have questions on access to the Private PAIR system, contact the Electronic Business Center (EBC) at 866-217-9197 (toll-free).

  
APR

571-273-4452

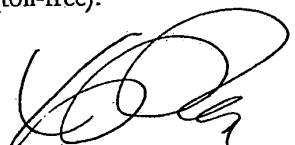
  
XUAN M. THAI  
SUPERVISORY PATENT EXAMINER  
TC3700



<b>Notice of References Cited</b>	Application/Control No. 09/688,501	Applicant(s)/Patent Under Reexamination JOSHI, SHRIDHAR P.	
	Examiner Alex P. Rada	Art Unit 3713	Page 1 of 1

**U.S. PATENT DOCUMENTS**

*	Document Number Country Code-Number-Kind Code	Date MM-YYYY	Name	Classification
A	US-6,409,602	06-2002	Wiltshire et al.	463/42
B	US-6,508,710	01-2003	Paravia et al.	463/42
C	US-6,001,016	12-1999	Walker et al.	463/42
D	US-6,508,709	01-2003	Karmarkar, Jayant S.	463/42
E	US-			
F	US-			
G	US-			
H	US-			
I	US-			
J	US-			
K	US-			
L	US-			
M	US-			

**FOREIGN PATENT DOCUMENTS**

*	Document Number Country Code-Number-Kind Code	Date MM-YYYY	Country	Name	Classification
N					
O					
P					
Q					
R					
S					
T					

**NON-PATENT DOCUMENTS**

*	Include as applicable: Author, Title Date, Publisher, Edition or Volume, Pertinent Pages)
U	
V	
W	
X	

\*A copy of this reference is not being furnished with this Office action. (See MPEP § 707.05(a).)  
Dates in MM-YYYY format are publication dates. Classifications may be US or foreign.



UNITED STATES PATENT AND TRADEMARK OFFICE

UNITED STATES DEPARTMENT OF COMMERCE  
United States Patent and Trademark Office  
Address: COMMISSIONER FOR PATENTS  
P.O. Box 1450  
Alexandria, Virginia 22313-1450  
www.uspto.gov

APPLICATION NO.	FILING DATE	FIRST NAMED INVENTOR	ATTORNEY DOCKET NO.	CONFIRMATION NO.
09/688,501	10/16/2000	Shridhar P. Joshi	47079-00077	3225

30223 7590 01/25/2006  
JENKENS & GILCHRIST, P.C.  
225 WEST WASHINGTON  
SUITE 2600  
CHICAGO, IL 60606

RECEIVED  
JAN 30 2006  
CHI DOCKETING

EXAMINER

RADA, ALEX P

ART UNIT PAPER NUMBER

3713

DATE MAILED: 01/25/2006

Please find below and/or attached an Office communication concerning this application or proceeding.

DOCKETED

INIT. JR DATE: 1/30/06  
Resp. Due  
ACTION: \_\_\_\_\_ DATE: 2/2/06  
AA Deadline 5/2/06

<b>Advisory Action Before the Filing of an Appeal Brief</b>	<b>Application No.</b> 09/688,501	<b>Applicant(s)</b> JOSHI, SHRIDHAR P.	
	<b>Examiner</b> Alex P. Rada	<b>Art Unit</b> 3713	

--The MAILING DATE of this communication appears on the cover sheet with the correspondence address --

THE REPLY FILED 03 January 2006 FAILS TO PLACE THIS APPLICATION IN CONDITION FOR ALLOWANCE.

1.  The reply was filed after a final rejection, but prior to or on the same day as filing a Notice of Appeal. To avoid abandonment of this application, applicant must timely file one of the following replies: (1) an amendment, affidavit, or other evidence, which places the application in condition for allowance; (2) a Notice of Appeal (with appeal fee) in compliance with 37 CFR 41.31; or (3) a Request for Continued Examination (RCE) in compliance with 37 CFR 1.114. The reply must be filed within one of the following time periods:

- a)  The period for reply expires \_\_\_\_\_ months from the mailing date of the final rejection.  
b)  The period for reply expires on: (1) the mailing date of this Advisory Action, or (2) the date set forth in the final rejection, whichever is later. In no event, however, will the statutory period for reply expire later than SIX MONTHS from the mailing date of the final rejection.  
Examiner Note: If box 1 is checked, check either box (a) or (b). ONLY CHECK BOX (b) WHEN THE FIRST REPLY WAS FILED WITHIN TWO MONTHS OF THE FINAL REJECTION. See MPEP 706.07(f).

Extensions of time may be obtained under 37 CFR 1.136(a). The date on which the petition under 37 CFR 1.136(a) and the appropriate extension fee have been filed is the date for purposes of determining the period of extension and the corresponding amount of the fee. The appropriate extension fee under 37 CFR 1.17(a) is calculated from: (1) the expiration date of the shortened statutory period for reply originally set in the final Office action; or (2) as set forth in (b) above, if checked. Any reply received by the Office later than three months after the mailing date of the final rejection, even if timely filed, may reduce any earned patent term adjustment. See 37 CFR 1.704(b).

**NOTICE OF APPEAL**

2.  The Notice of Appeal was filed on \_\_\_\_\_. A brief in compliance with 37 CFR 41.37 must be filed within two months of the date of filing the Notice of Appeal (37 CFR 41.37(a)), or any extension thereof (37 CFR 41.37(e)), to avoid dismissal of the appeal. Since a Notice of Appeal has been filed, any reply must be filed within the time period set forth in 37 CFR 41.37(a).

**AMENDMENTS**

3.  The proposed amendment(s) filed after a final rejection, but prior to the date of filing a brief, will not be entered because  
(a)  They raise new issues that would require further consideration and/or search (see NOTE below);  
(b)  They raise the issue of new matter (see NOTE below);  
(c)  They are not deemed to place the application in better form for appeal by materially reducing or simplifying the issues for appeal; and/or  
(d)  They present additional claims without canceling a corresponding number of finally rejected claims.

NOTE: \_\_\_\_\_. (See 37 CFR 1.116 and 41.33(a)).

4.  The amendments are not in compliance with 37 CFR 1.121. See attached Notice of Non-Compliant Amendment (PTOL-324).  
5.  Applicant's reply has overcome the following rejection(s): \_\_\_\_\_.  
6.  Newly proposed or amended claim(s) \_\_\_\_\_ would be allowable if submitted in a separate, timely filed amendment canceling the non-allowable claim(s).  
7.  For purposes of appeal, the proposed amendment(s): a)  will not be entered, or b)  will be entered and an explanation of how the new or amended claims would be rejected is provided below or appended.  
The status of the claim(s) is (or will be) as follows:  
Claim(s) allowed: \_\_\_\_\_  
Claim(s) objected to: \_\_\_\_\_  
Claim(s) rejected: 37-62.  
Claim(s) withdrawn from consideration: \_\_\_\_\_

**AFFIDAVIT OR OTHER EVIDENCE**

8.  The affidavit or other evidence filed after a final action, but before or on the date of filing a Notice of Appeal will not be entered because applicant failed to provide a showing of good and sufficient reasons why the affidavit or other evidence is necessary and was not earlier presented. See 37 CFR 1.116(e).  
9.  The affidavit or other evidence filed after the date of filing a Notice of Appeal, but prior to the date of filing a brief, will not be entered because the affidavit or other evidence failed to overcome all rejections under appeal and/or appellant fails to provide a showing a good and sufficient reasons why it is necessary and was not earlier presented. See 37 CFR 41.33(d)(1).  
10.  The affidavit or other evidence is entered. An explanation of the status of the claims after entry is below or attached.

**REQUEST FOR RECONSIDERATION/OTHER**

11.  The request for reconsideration has been considered but does NOT place the application in condition for allowance because:  
See Continuation Sheet.  
12.  Note the attached Information Disclosure Statement(s). (PTO/SB/08 or PTO-1449) Paper No(s) \_\_\_\_\_  
13.  Other: \_\_\_\_\_

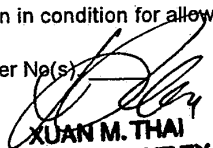
  
**XUAN M. THAI**  
**SUPERVISORY PATENT EXAMINER**  
TC3700

Continuation of 11. does NOT place the application in condition for allowance because: Applicant contends that the claimed invention is directed toward a remote gaming method and a computer therefore, where players at gaming terminal located outside a gaming establishment may play gaming machines located inside the gaming establishment.

The definition of the word "remote" is separated by an interval or space greater than usual. Wiltshire discloses communication pathways that are remote having any type of local area, wide area, or global communication pathways, including the Internet and th World Wide Web (col. 5, lines 31-33). Thus Wiltshire is capable of a remote gaming method and a computer, where players at gaming terminals located outside (remote) a gaming establishment playing gaming mahcines located inside the gaming establishment. Applicant contends that the examiner has failed to meet the standard for raising a functinally equivalent rejection.

The examiner notes that the statement used in the office action on page 9, lines 5-8 was to make a point that physical gaming machines were re-introcudes as video based gaming machine, which is very commin and very well known in industry today. As noted in the Final office action, when a gaming machine calculates the game results on the gaming machine at a gaming site, the functional equivalent to that would be a gaming machine running a program and the calculations are carried out on a sever located at a gaming a site and routed back to the gaming machine at the gaming site. The only difference is the gaming results are calculated on the server and communicated back to the gaming machine instead of calculating the gaming results at the gaming machine itself. If you take the same computer based video gaming machine and place that video game program on a home PC, the only things that have changed are how the program (results and calculations) are being communicated and how wagers are accepted and payouts awarded. Therefore, a host/server computer executing a casino game program is functionally equivalent to a gaming machine in a gaming establishment..



Application No. (if known): 09/688501

Attorney Docket No.: 47079-00077

### Certificate of Mailing under 37 CFR 1.8

I hereby certify that this correspondence is being deposited with the United States Postal Service with sufficient postage as first class mail in an envelope addressed to:

Mail Stop Appeal Brief - Patents  
U.S. Patent and Trademark Office  
Commissioner for Patents  
P.O. Box 1450  
Alexandria, VA 22313-1450

on March 8, 2006  
Date

Signature

Daniel G. Nguyen

Typed or printed name of person signing Certificate

42,933

Registration Number, if applicable

(713) 951-3300

Telephone Number

Note: Each paper must have its own certificate of mailing, or this certificate must identify each submitted paper.

Appeal Brief Transmittal (1 page)  
Appeal Brief (23 pages)  
Appendices A-F



UNITED STATES PATENT AND TRADEMARK OFFICE

UNITED STATES DEPARTMENT OF COMMERCE  
United States Patent and Trademark Office  
Address: COMMISSIONER FOR PATENTS  
P.O. Box 1450  
Alexandria, Virginia 22313-1450  
www.uspto.gov

APPLICATION NO.	FILING DATE	FIRST NAMED INVENTOR	ATTORNEY DOCKET NO.	CONFIRMATION NO.
09/688,501	10/16/2000	Shridhar P. Joshi	47079-00077	3225
30223	7590	07/11/2006	EXAMINER	
JENKENS & GILCHRIST, P.C. 225 WEST WASHINGTON SUITE 2600 CHICAGO, IL 60606			ART UNIT	PAPER NUMBER

DATE MAILED: 07/11/2006

Please find below and/or attached an Office communication concerning this application or proceeding.

<b>Notification of Non-Compliant Appeal Brief (37 CFR 41.37)</b>	<b>Application No.</b> 09/688,501	<b>Applicant(s)</b> JOSHI, SHRIDHAR P.	
	<b>Examiner</b> Alex P. Rada	<b>Art Unit</b> 3712	

--The MAILING DATE of this communication appears on the cover sheet with the correspondence address--

The Appeal Brief filed on 11 May 2006 is defective for failure to comply with one or more provisions of 37 CFR 41.37.

To avoid dismissal of the appeal, applicant must file an amended brief or other appropriate correction (see MPEP 1205.03) within **ONE MONTH** or **THIRTY DAYS** from the mailing date of this Notification, whichever is longer. **EXTENSIONS OF THIS TIME PERIOD MAY BE GRANTED UNDER 37 CFR 1.136.**

1.  The brief does not contain the items required under 37 CFR 41.37(c), or the items are not under the proper heading or in the proper order.
2.  The brief does not contain a statement of the status of all claims, (e.g., rejected, allowed, withdrawn, objected to, canceled), or does not identify the appealed claims (37 CFR 41.37(c)(1)(iii)).
3.  At least one amendment has been filed subsequent to the final rejection, and the brief does not contain a statement of the status of each such amendment (37 CFR 41.37(c)(1)(iv)).
4.  (a) The brief does not contain a concise explanation of the subject matter defined in each of the independent claims involved in the appeal, referring to the specification by page and line number and to the drawings, if any, by reference characters; and/or (b) the brief fails to: (1) identify, for each independent claim involved in the appeal and for each dependent claim argued separately, every means plus function and step plus function under 35 U.S.C. 112, sixth paragraph, and/or (2) set forth the structure, material, or acts described in the specification as corresponding to each claimed function with reference to the specification by page and line number, and to the drawings, if any, by reference characters (37 CFR 41.37(c)(1)(v)).
5.  The brief does not contain a concise statement of each ground of rejection presented for review (37 CFR 41.37(c)(1)(vi)).
6.  The brief does not present an argument under a separate heading for each ground of rejection on appeal (37 CFR 41.37(c)(1)(vii)).
7.  The brief does not contain a correct copy of the appealed claims as an appendix thereto (37 CFR 41.37(c)(1)(viii)).
8.  The brief does not contain copies of the evidence submitted under 37 CFR 1.130, 1.131, or 1.132 or of any other evidence entered by the examiner **and relied upon by appellant in the appeal**, along with a statement setting forth where in the record that evidence was entered by the examiner, as an appendix thereto (37 CFR 41.37(c)(1)(ix)).
9.  The brief does not contain copies of the decisions rendered by a court or the Board in the proceeding identified in the Related Appeals and Interferences section of the brief as an appendix thereto (37 CFR 41.37(c)(1)(x)).
10.  Other (including any explanation in support of the above items):

For a single ground of rejection, Appellant is required to argue all the claims together or, if Appellant wishes to argue some claims separately, Appellant must show why the claims are separately patentable. Merely arguing that the claims contain additional limitations is not considered a valid showing of separate patentability. Appellant has argued claims separately without showing why they are separately patentable. Therefore the appeal brief is improper.

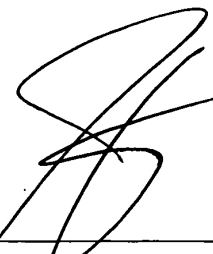

**JOHN M. HOTALING, II  
PRIMARY EXAMINER**

AF 90

PTO/SB/21 (09-04)

Approved for use through 07/31/2006. OMB 0651-0031

U.S. Patent and Trademark Office; U.S. DEPARTMENT OF COMMERCE

Under the Paperwork Reduction Act of 1995, no persons are required to respond to a collection of information unless it displays a valid OMB control number.



# TRANSMITTAL FORM

(to be used for all correspondence after initial filing)

Application Number		09/688501
Filing Date		October 16, 2000
First Named Inventor		Shridhar P. Joshi
Art Unit		3714
Examiner Name		A. P. Rada
Attorney Docket Number		47079-00077USPT
Total Number of Pages in This Submission	6	

## ENCLOSURES (Check all that apply)

<input type="checkbox"/> Fee Transmittal Form	<input type="checkbox"/> Drawing(s)	<input type="checkbox"/> After Allowance Communication to TC
<input type="checkbox"/> Fee Attached	<input type="checkbox"/> Licensing-related Papers	<input type="checkbox"/> Appeal Communication to Board of Appeals and Interferences
<input type="checkbox"/> Amendment/Reply	<input type="checkbox"/> Petition	<input checked="" type="checkbox"/> Appeal Communication to TC (Appeal Notice, Brief, Reply Brief)
<input type="checkbox"/> After Final	<input type="checkbox"/> Petition to Convert to a Provisional Application	<input type="checkbox"/> Proprietary Information
<input type="checkbox"/> Affidavits/declaration(s)	<input type="checkbox"/> Power of Attorney, Revocation Change of Correspondence Address	<input type="checkbox"/> Status Letter
<input type="checkbox"/> Extension of Time Request	<input type="checkbox"/> Terminal Disclaimer	<input checked="" type="checkbox"/> Other Enclosure(s) (please identify below):
<input type="checkbox"/> Express Abandonment Request	<input type="checkbox"/> Request for Refund	Certificate of mailing Postcard
<input type="checkbox"/> Information Disclosure Statement	<input type="checkbox"/> CD, Number of CD(s) _____	
<input type="checkbox"/> Certified Copy of Priority Document(s)	<input type="checkbox"/> Landscape Table on CD	
<input type="checkbox"/> Reply to Missing Parts/ Incomplete Application	<input type="text"/> Remarks	
<input type="checkbox"/> Reply to Missing Parts under 37 CFR 1.52 or 1.53		

## SIGNATURE OF APPLICANT, ATTORNEY, OR AGENT

Firm Name	JENKENS & GILCHRIST, A PROFESSIONAL CORPORATION		
Signature			
Printed name	Daniel G. Nguyen		
Date	August 11, 2006	Reg. No.	42,933





Docket No.: 47079-00077USPT  
(PATENT)

**IN THE UNITED STATES PATENT AND TRADEMARK OFFICE**

In re Patent Application of:  
Shridhar P. Joshi

Application No.: 09/688501

Confirmation No.: 3225

Filed: October 16, 2000

Art Unit: 3714

For: METHOD OF TRANSFERRING GAMING  
DATA ON A GLOBAL COMPUTER  
NETWORK

Examiner: A. P. Rada

**RESPONSE TO NOTICE OF NON-COMPLIANT APPEAL BRIEF**

Mail Stop Appeal Brief - Patents  
Commissioner for Patents  
P.O. Box 1450  
Alexandria, VA 22313-1450

Dear Sir:

In response to the Notice of Non-Compliant Appeal Brief dated July 11, 2006, please reconsider Appellant's currently pending appeal brief in view of the remarks herein.

Appellant's appeal brief filed May 8, 2006, was deemed by the Examiner to be non-compliant under 37 CFR § 41.37(c)(1)(vii) (the "Arguments Section"). The Examiner explained the reason for the notice of non-compliance as follows:

For a single ground of rejection, Appellant is required to argue all the claims together or, if Appellant wishes to argue some claims separately, Appellant must show why the claims are separately patentable. Merely arguing that the claims contain additional limitations is not considered a valid showing of separate patentability. Appellant has argued claims separately without showing why they are separately patentable. Therefore the appeal brief is improper.

*Notice of Non-Compliant Appeal Brief dated July 11, 2006, p. 2.*

During a telephone conference on July 25, 2006, the Examiner clarified that Section VII, Item D on page 18 of the appeal brief is non-compliant because it argues one or more dependent

CHICAGO 335364v1 47079-00077

claims without showing how those dependent claims are separately patentable over their respective independent claims. The Examiner explained that while Appellant had made a showing of separate patentability over the prior art, Appellant had failed to show why the dependent claims were “separately patentable” over the independent claims.

In a follow-up telephone conference on August 8, 2006, the Examiner reiterated his position that arguments directed separately to one or more dependent claims **must** show how those dependent claims are separately patentable over both the prior art **and** the independent claims. The Examiner further stated during the second telephone conference that a showing of separate patentability over the independent claims would necessarily provoke a Restriction Requirement for the argued dependent claims. In other words, Appellant’s options were to (i) withdraw all arguments on the separate patentability of any dependent claims, or (ii) argue in a manner that would cause the Examiner to issue a Restriction Requirement. When asked, however, the Examiner stated he was not aware of any authority for his position, only that this is what he “has always been told.”

Appellant is very grateful for the courtesy of the two telephone conferences, but must respectfully disagree with the Examiner’s position for the following reasons: (1) it is inconsistent with the opening premise of the Arguments Section of 37 CFR § 41.37, (2) it is unreasonable in view of the provision of the Arguments Section permitting claims to be argued separately, and (3) it is contrary to the opinions of personnel at the Board of Patent Appeals and Interferences and the Office of Patent Legal Administration.

1. *The Examiner’s position is inconsistent with the opening premise of 37 CFR § 41.37(c)(1)(vii)*

The first sentence of the Arguments Section (reproduced below) requires Appellants to state their contentions with respect to each **ground of rejection**. As the Examiner is aware, the grounds of rejection at issue on appeal are based entirely on the prior art. Therefore, in accordance with the first sentence of the Arguments Section, Appellant should be required to make a showing of separate patentability **only** with respect to the prior art. Appellant respectfully submits that requiring Appellant to also make a showing of separate patentability over the independent claims is inconsistent with the Arguments Section’s opening premise.

The contentions of Appellant with respect to each **ground of rejection** presented for review in paragraph (c)(1)(vi) of this section, and the basis therefor, with citations of the statutes, regulations, authorities, and parts of the record relied on. Any arguments or authorities not included in the brief or a reply brief filed pursuant to § 41.41 will be refused consideration by the Board, unless good cause is shown. Each ground of rejection must be treated under a separate heading. For each ground of rejection applying to two or more claims, **the claims may be argued separately or as a group**. When multiple claims subject to the same ground of rejection are argued as a group by Appellant, the Board may select a single claim from the group of claims that are argued together to decide the appeal with respect to the group of claims as to the ground of rejection on the basis of the selected claim alone. Notwithstanding any other provision of this paragraph, the failure of Appellant to separately argue claims which Appellant has grouped together shall **constitute a waiver of any argument that the Board must consider the patentability of any grouped claim separately**. Any claim argued separately should be placed under a subheading identifying the claim by number. Claims argued as a group should be placed under a subheading identifying the claims by number. A statement which merely points out what a claim recites will not be considered an argument for separate patentability of the claim.

37 CFR § 41.37(c)(1)(vii) (*emphasis added*).

2. *The Examiner's position is unreasonable in view of the provision of the Arguments Section permitting claims to be argued separately*

In addition, the fourth sentence of the Arguments Section (highlighted above) allows claims to be argued as a group or separately for each ground of rejection. Indeed, failure to separately argue a claim constitutes a **waiver** of arguments with respect to that claim. Thus, the Arguments Section clearly contemplates and even encourages Appellants to argue claims separately. However, if the Examiner's approach were followed, such a strategy would result in a Restriction Requirement because Appellant would be required to show separate patentability over the independent claims in the arguments. A Restriction Requirement is clearly not an outcome that the Arguments Section intended at this advance stage of the prosecution and moreover would be **unfair** to Appellant given the numerous opportunities the Examiner has already had to raise such a Restriction Requirement. Accordingly, Appellant respectfully submits that the Examiner's position is unreasonable in view of the provision of the Arguments Section permitting claims to be argued separately.

3. *The Examiner's position contradicts the opinions of personnel at the Board of Patent Appeals and Interferences and the Office of Patent Legal Administration*

On August 11, 2006, in an attempt to obtain further guidance, Appellant separately solicited second opinions from Examiner Dale Shaw at the Board of Patent Appeals and Interferences and Attorney Robert Spar in the Office of Patent Legal Administration. After hearing Appellant's explanation as outlined above, both Examiner Shaw and Attorney Spar expressed the opinion that the Arguments Section did **not** require a showing of separate patentability over the independent claims for dependent claims that are argued separately. Appellant therefore respectfully submits that the Examiner's position is contrary to the opinions of personnel at the Board of Patent Appeals and Interferences and the Office of Patent Legal Administration.

**CONCLUSION**

In view of the above remarks, Appellant believes the currently pending appeal brief is in compliance with all provisions of 37 CFR § 41.37 and withdrawal of the Notice of Non-Compliant Appeal Brief is respectfully requested.

Dated: August 11, 2006

Respectfully submitted,

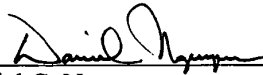
By 

Daniel G. Nguyen

Registration No.: 42,933

JENKENS & GILCHRIST, A PROFESSIONAL  
CORPORATION

225 W. Washington, Ste. 2600

Chicago, Illinois 60606-3418

(312) 425-3900

Attorneys For Appellant



Under the Paperwork Reduction Act of 1995, no persons are required to respond to a collection of information unless it displays a valid OMB control number.

Application No. (if known): 09/688501

Attorney Docket No.: 47079-00077USPT

## Certificate of Mailing under 37 CFR 1.8

I hereby certify that this correspondence is being deposited with the United States Postal Service with sufficient postage as first class mail in an envelope addressed to:

Mail Stop Appeal Brief - Patents  
Commissioner for Patents  
P.O. Box 1450  
Alexandria, VA 22313-1450

on August 11, 2006  
Date

Signature

Daniel G. Nguyen

Typed or printed name of person signing Certificate

42,933  
Registration Number, if applicable

(713) 951-3354  
Telephone Number

Note: Each paper must have its own certificate of mailing, or this certificate must identify each submitted paper.

Response to Notice of Non-Compliant Appeal Brief (4 pages)  
Transmittal (1 page)  
Postcard (1 page)



UNITED STATES PATENT AND TRADEMARK OFFICE

UNITED STATES DEPARTMENT OF COMMERCE  
United States Patent and Trademark Office  
Address: COMMISSIONER FOR PATENTS  
P.O. Box 1450  
Alexandria, Virginia 22313-1450  
www.uspto.gov

APPLICATION NO.	FILING DATE	FIRST NAMED INVENTOR	ATTORNEY DOCKET NO.	CONFIRMATION NO.
09/688,501	10/16/2000	Shridhar P. Joshi	47079-00077	3225

30223 7590 10/30/2006  
JENKENS & GILCHRIST, P.C.  
225 WEST WASHINGTON  
SUITE 2600  
CHICAGO, IL 60606

EXAMINER

RADA, ALEX P

ART UNIT PAPER NUMBER

3714

DATE MAILED: 10/30/2006

Please find below and/or attached an Office communication concerning this application or proceeding.



UNITED STATES PATENT AND TRADEMARK OFFICE

Commissioner for Patents  
United States Patent and Trademark Office  
P.O. Box 1450  
Alexandria, VA 22313-1450  
www.uspto.gov

**BEFORE THE BOARD OF PATENT APPEALS  
AND INTERFERENCES**

Application Number: 09/688,501  
Filing Date: October 16, 2000  
Appellant(s): JOSHI, SHRIDHAR P.

**MAILED**  
**OCT 30 2006**  
**GROUP 3700**

---

Daniel G. Nguyen  
For Appellant

**EXAMINER'S ANSWER**

This is in response to the appeal brief filed May 11, 2006 appealing from the Office action mailed November 11, 2005.

**(1) Real Party in Interest**

A statement identifying by name the real party in interest is contained in the brief.

**(2) Related Appeals and Interferences**

The examiner is not aware of any related appeals, interferences, or judicial proceedings which will directly affect or be directly affected by or have a bearing on the Board's decision in the pending appeal.

**(3) Status of Claims**

The statement of the status of claims contained in the brief is correct.

**(4) Status of Amendments After Final**

The appellant's statement of the status of amendments after final rejection contained in the brief is correct.

**(5) Summary of Claimed Subject Matter**

The summary of claimed subject matter contained in the brief is correct.

**(6) Grounds of Rejection to be Reviewed on Appeal**

The appellant's statement of the grounds of rejection to be reviewed on appeal is correct.

**(7) Claims Appendix**

The copy of the appealed claims contained in the Appendix to the brief is correct.



**(8) Evidence Relied Upon**

6,409,602	Wiltshire et al.	6-2002
6,001,016	Walker et al.	12-1999
6,508,709	Karmarkar	1-2003
6,508,710	Paravia et al.	1-2003

**(9) Grounds of Rejection**

The following ground(s) of rejection are applicable to the appealed claims:

***Claim Rejections - 35 USC § 103***

1. The following is a quotation of 35 U.S.C. 103(a) which forms the basis for all obviousness rejections set forth in this Office action:

(a) A patent may not be obtained though the invention is not identically disclosed or described as set forth in section 102 of this title, if the differences between the subject matter sought to be patented and the prior art are such that the subject matter as a whole would have been obvious at the time the invention was made to a person having ordinary skill in the art to which said subject matter pertains. Patentability shall not be negated by the manner in which the invention was made.

2. Claims 37-38 are rejected under 35 U.S.C. 103(a) as being unpatentable over Wiltshire et al. (US 6,409,602) in view of Paravia et al. (US 6,508,710).

3. Wiltshire et al discloses the following:

Accessing via a remote terminal (client/terminal), a gaming site (310 of figure 3) on a global computer network (column 8, lines 15-34) connected to the remote terminal (client/terminal), selecting a game of chance from a plurality of gaming machine located at a gaming establishment for remote play (figures 4b-9D), the remote terminal being located outside the gaming establishment, placing a wager for

playing the selected game and receiving randomly-generated text or graphical outcome data at the remote terminal for the selected game the outcome data being generated by one of the plurality of gaming machines at the gaming establishment and relayed to the gaming site through a gaming server connected to the gaming site, in which the examiner interprets the server/host containing the different programs and data of the different chance game to be a functional equivalent to placing a wager for playing the selected game and receiving randomly-generated text or graphical outcome data at the remote terminal for the selected game the outcome data being generated by one of the plurality of gaming machines at the gaming establishment and relayed to the gaming site through a gaming server connected to the gaming site (column 7, lines 7-56 and figures 2-3) as recited in claims 37-38.

Wiltshire et al does expressly disclose the following:

Providing via the remote terminal, personal identification information to the gaming site as recited in claims 37-38.

Paravia et al teaches the following:

Providing via the remote terminal, personal identification information to the gaming site (column 6, lines 49-55 and item 142 of figure 2) as recited in claims 37-38. By having providing personal identification information to the gaming site, one of ordinary skill in the art would provide a verification and permission to game players that are permitted to play.

Therefore, it would have been obvious to one of ordinary skill in the art at the time of the invention was made to modify Wiltshire et al to include personal

Art Unit: 3714

identification information to the gaming site as taught Paravia et al to provide a verification and permission to game players that are permitted to play.

4. Claims 39-62 are rejected under 35 U.S.C. 103(a) as being unpatentable over Wiltshire et al. (US 6,409,602) in view of Walker et al. (US 6,001,016).

5. Wiltshire et al discloses the following:

Establishing a communication link between the remote terminal (client/terminal) and a gaming site (310 of figure 3) on a global computer network (column 8, lines 15-34), the gaming site in communication with a gaming server (server/host), selecting a gaming machine (figures 4B-9D) at the gaming establishment using the remote terminal, making a wager to play the selected gaming machine, receiving outcome data, including game outcome at the remote terminal resulting from a play of the gaming machine (figures 4B-9D), and generating a payout if the game outcome meets predetermined criteria (figure 4B, column 7, lines 7-56, and column 8, lines 15-34) as recited in claim 39.

The game outcome resulting from the server initiating game play on the selected gaming machine (column 8, lines 42-65) as recited in claim 50.

The remote computer having a microprocessor, memory connected to the microprocessor and including instructions for controlling the microprocessor, and the microprocessor being operative with the instructions in the memory to receive information identifying a plurality of local gaming machine located within the gaming establishment from a gaming server, receive a text or graphical outcome resulting from a local play of each of the selected gaming machines and generate payout if the

outcome meets predetermined criteria (figures 4B-9D, column 6, line 44 – column 7, line 6, column 7, lines 7-56, and column 8, lines 15-34) as recited in claim 52.

The gaming server having means for receiving information identifying a plurality of gaming machines (figures 4B-9D) each engaged in play within the gaming establishment, means for receiving a text or graphical outcome resulting from a ply of the selected gaming machines and means for generating a payout if the outcome meets predetermined criteria (figures 4B-9D, column 6, line 44 – column 7, line 6, column 7, lines 7-56, and column 8, lines 15-34) as recited in claim 62.

Wiltshire et al does not expressly disclose the following:

The gaming server collecting outcome data from the gamine machines located inside the gaming establishment as recited in claims 39, 52 and 62.

The outcome data having information identifying the value of the payout and simulate a display of the game outcome at the remote location as recited in claims 40 and 59.

The outcome data to simulate a display of the game outcome on the remote terminal as recited in claim 41.

The selected gaming machine is a slot machine wherein the outcome data includes reel position as recited in claims 42, 48, 53, and 60.

The selected gaming machine is a video poker machine including a display for displaying a poker hand as recited in claims 43 and 58.

The receiving outcome data includes receiving outcome data from a plurality of gaming machine form remote play as recited in claim 44.

The outcome data includes a gaming machine identifier and gaming machine type as recited in claim 45-46 and 55-56.

The outcome data including receiving player preferences as recited in claims 47 and 57.

A player identifier and transmitting the player identifier for identification of the player as recited in claims 49 and 61.

Walker et al teaches the following:

The gaming server collecting outcome data from the gaming machines located inside the gaming establishment (figure 1) as recited in claims 39, 52 and 62.

The outcome data having information identifying the value of the payout and simulate a display of the game outcome at the remote location (column 5, lines 33-37) as recited in claims 40 and 59.

The outcome data to simulate a display of the game outcome on the remote terminal (column 5, lines 33-37) as recited in claim 41.

The selected gaming machine is a slot machine wherein the outcome data includes reel position (column 5, lines 33-37) as recited in claims 42, 48, 53-54, and 60.

The selected gaming machine is a video poker machine including a display for displaying a poker hand (column 5, lines 33-37) as recited in claims 43 and 58.

The receiving outcome data includes receiving outcome data from a plurality of gaming machine form remote play (column 6, lines 45-56) as recited in claim 44.

The outcome data includes a gaming machine identifier and gaming machine type (figure 5 and column 6, lines 31-44) as recited in claim 45-46 and 55-56.

The outcome data including receiving player preferences (column 6, lines 8-30) as recited in claims 47 and 57.

A player identifier and transmitting the player identifier for identification of the player (column 6, lines 8-30) as recited in claims 49 and 61.

The outcome results from the manual game play on the selected gaming machine (summary) as recited in claim 51. By transmitting data from the gaming machine located in the gaming establishment, one of ordinary skill in the art would provide a system that does not require human intervention and live video transmission of the game being played.

Therefore, it would have been obvious to one of ordinary skill in the art at the time of the invention was made to modify Wiltshire et al to include the gaming server collecting outcome data from the gaming machines located inside the gaming establishment, the outcome data having information identifying the value of the payout and simulate a display of the game outcome at the remote location, the outcome data to simulate a display of the game outcome on the remote terminal, the selected gaming machine is a slot machine wherein the outcome data includes reel position, the selected gaming machine is a video poker machine including a display for displaying a poker hand, the receiving outcome data includes receiving outcome data from a plurality of gaming machine from remote play, the outcome data includes a gaming machine identifier and gaming machine type, the outcome data including receiving player preferences, and a player identifier and transmitting the player identifier for identification of the player as taught by Walker et al to provide a

system that does not require human intervention and live video transmission of the game being played.

**(10) Response to Argument**

Appellant contends that Wiltshire and Paravia do not teach or suggest remote play of a game of chance from a plurality of “gaming machines” in a gaming establishment. Appellant further contends that the “host/server” computer executing casino software is not functionally equivalent to “gaming machines” in a gaming establishment.

The examiner respectfully disagrees. Wiltshire discloses a virtual casino where a player can choose which type of game to play as shown in figures 4B to 9D. The gaming establishment is the virtual casino on the server/host computer (110) having a plurality of gaming machines being played remotely from the client/terminal computers as shown in figure 1. Gaming programs and the associated gaming display generation programs are executed entirely on the server/host computer, with only input wagering and output screen display related operations being executed on the client/terminal computers. The communication (130) from the client/terminal computers to the server/host computers (110) are achieved through any type of local area, wide area or global communication pathways, including the Internet and the World Wide Web.

In response to applicant’s arguments that the host/server computer executing casino game programs is not a functional equivalent to a gaming machine in a gaming establishment, it is noted that a gaming machine at a gaming establishment is just a computer that runs a program either on the gaming machine or communication to a server like in Walker (6,001,016), Karmarkar (6,508,709), and Paravia (6,508,710) to name a few. Since a physical embodiment of various games have been re-implemented into microcomputer-based video gaming stations for the last 20 years

Art Unit: 3714

(Wiltshire-background), it is obvious to a person of ordinary skill in the art would recognize that gaming machine can be re-implemented into a video gaming system, which is nothing more than a cabinet having a monitor, a program either on the gaming machine or communication to a server, and some means of accepting and dispensing wagers. This reimplementation has been motivated by reliability, manufacturability, and ultimately, total cost of maintaining the computer (video) gaming station during its useful life. Computer systems having been devised where a cluster of gaming stations are controlled by a central computer. The central computer can "download" and thereby change the game program being executed by a gaming station or even allow players at different gaming stations to play against one another. When a gaming machine calculates the game results on the gaming machine at a gaming site, the functional equivalent to that would be a gaming machine running a program and the calculations are carried out on a server located at a gaming site and routed back to the gaming machine at the gaming site. The only difference is the gaming results are calculated on the server and communicated back to the gaming machine instead of calculating the gaming results at the gaming machine itself. If you take the same computer based video gaming machine and place that video game program on a home PC, the only things that have changed are how the program (results and calculations) are being communicated and how wagers are accepted and payouts awarded. Therefore, a host/server computer executing a casino game program is functionally equivalent to a gaming machine in a gaming establishment.

Appellant contends that Wiltshire and Walker fail to teach or suggest selecting a gaming machine within a gaming establishment from "a remote terminal located outside the gaming establishment."

In response to appellant's arguments, the recitation a gaming machine with a gaming establishment from a remote terminal located outside the gaming establishment has not been given



Art Unit: 3714

patentable weight because the recitation occurs in the preamble. A preamble is generally not accorded any patentable weight where it merely recites the purpose of a process or the intended use of a structure, and where the body of the claim does not depend on the preamble for completeness but, instead, the process steps or structural limitations are able to stand alone. See *In re Hiraio*, 535 F.2d 67, 190 USPQ 15 (CCPA 1976) and *Kropa v. Robie*, 187 F.2d 150, 152, 88 USPQ 478, 481 (CCPA 1951). The claimed invention as disclosed by Wiltshire recites establishing a communication link between the remote terminal (client/terminal) and a gaming site (310 of figure 3) on a global computer network (column 8, lines 15-34), the gaming site in communication with a gaming server (server/host), selecting a gaming machine (figures 4B-9D) at the gaming establishment using the remote terminal, where the selection of a game like video poker, keno, slots, big bertha, black etc., is selecting a gaming machine at the gaming establishment using the remote terminal. Wiltshire further discloses making a wager to play the selected gaming machine, receiving outcome data, including game outcome at the remote terminal resulting from a play of the gaming machine (figures 4B-9D), and generating a payout if the game outcome meets predetermined criteria (figure 4B, column 7, lines 7-56, and column 8, lines 15-34). Wiltshire discloses a gaming site (website) in figure 3, item 310. Wiltshire discloses in col. 8, lines 15-34 that a user accesses a website (gaming site) using a web browser such as Internet Explorer, Netscape Navigator or the like and downloads the program from the website (gaming site). The gaming data or information to the client/terminal is executed from the server/host computer, which updates the state (randomly-generated or graphical outcome data) of the game accordingly (col. 7, lines 7-44 and figure 2). Wiltshire further discloses connecting to the host/server computer from a client/terminal computer, which the client/terminal is a remote terminal located outside the gaming establishment by communication means of any local area, wide

area or global communication pathways, including the Internet and the World Wide Web. Walker was cited to teach the elements not expressly disclosed by Wiltshire as noted in the office action.

Appellant contends that Wiltshire and Walker fail to teach or suggest “relaying outcome data through a gaming site.”

In response to appellant's arguments, the recitation of “relaying outcome data through a gaming site” has not been given patentable weight because the recitation occurs in the preamble. A preamble is generally not accorded any patentable weight where it merely recites the purpose of a process or the intended use of a structure, and where the body of the claim does not depend on the preamble for completeness but, instead, the process steps or structural limitations are able to stand alone. See *In re Hirao*, 535 F.2d 67, 190 USPQ 15 (CCPA 1976) and *Kropa v. Robie*, 187 F.2d 150, 152, 88 USPQ 478, 481 (CCPA 1951). Wiltshire does disclose a gaming site (website) in figure 3, item 310. Wiltshire further discloses in col. 8, lines 15-34 that a user accesses a website (gaming site) using a web browser such as Internet Explorer, Netscape Navigator or the like and downloads the program from the website (gaming site). The gaming data or information to the client/terminal is executed from the server/host computer, which updates the state (randomly-generated or graphical outcome data) of the game accordingly (col. 7, lines 7-44 and figure 2). The program that gets downloaded to the client/terminal is nothing more than a user interface that connects to the server through the different communication means like the Internet and the World Wide Webb to name a few. The data coming from the sever/host through the Internet and/or the World Wide Webb to the client/terminal is the same as the outcome data being relayed through the gaming site to the remote terminal. Regardless of how the data is relayed through the gaming site or directly to the remote terminal, the data being relayed does not change the outcome of the game.

Appellant contends that Walker fails to teach or suggest outcome data that includes a “gaming machine type,” as required by claims 46 and 56.

The Examiner respectfully disagrees. Walker teaches in figure 5, col. 6, lines 31-44 that multiple records are kept for each record pertaining to the remote play session of a particular player, as identified by a remote wagering terminal ID number, number of slot machines to be accessed, slot machine type, bet per pull, outcomes credit balance etc. Walker further teaches that the outcome data includes all game activity-related information, which includes the type of game being played or game type. For example, if a user picks a slot machine to play, then the outcome data of slot machine being displayed on the screen would be the outcome of results of the spinning reels, win or loss, which is the gaming machine type.

Appellant contends that Walker fails to teach or suggest outcome data that includes “player preferences,” as required by claims 47 and 57.

The Examiner respectfully disagrees. Walker teaches that the outcome data includes all game activity-related information, which also includes the player preferences. Walker further teaches that a player enter play preferences at a remote wagering terminal and the remote wagering terminal transmits the play preference to a network sever that stores the play preferences. Based upon the play preferences, the network server identifies the outcome data from one or more slot machines and transmits this outcome data from those slot machines to the remote wagering terminal. In other words, if the player chooses to play one or more gaming machines at the same time the outcome data will transmit the outcome data of one or more gaming machines based on the player preference.

Appellant contends that Walker fails to teach or suggest a gaming sever initiating game play, as required by claims 50.

The Examiner respectfully disagrees. Walker was not used to disclose a gaming sever initiating game play. Wiltshire was used to disclose the game outcome resulting from the server initiating game play on the selected gaming machine on col. 8, lines 42-65.

**(11) Related Proceeding(s) Appendix**

No decision rendered by a court or the Board is identified by the examiner in the Related Appeals and Interferences section of this examiner's answer.

For the above reasons, it is believed that the rejections should be sustained.

Respectfully submitted,

Alex P. Rada

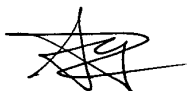

Conferees:

John Hotaling



**JOHN M. HOTALING, II  
PRIMARY EXAMINER**

Corbett Coburn

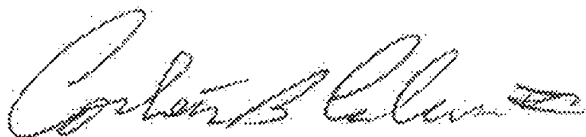

**CORBETT B. COBURN  
PRIMARY EXAMINER**



UNITED STATES PATENT AND TRADEMARK OFFICE

UNITED STATES DEPARTMENT OF COMMERCE  
United States Patent and Trademark Office  
Address: COMMISSIONER FOR PATENTS  
P.O. Box 1450  
Alexandria, Virginia 22313-1450  
www.uspto.gov

APPLICATION NO.	FILING DATE	FIRST NAMED INVENTOR	ATTORNEY DOCKET NO.	CONFIRMATION NO.
09/688,501	10/16/2000	Shridhar P. Joshi	47079-00077	3225
30223	7590	11/15/2006	EXAMINER	
JENKENS & GILCHRIST, P.C. 225 WEST WASHINGTON SUITE 2600 CHICAGO, IL 60606			RADA, ALEX P	
			ART UNIT	PAPER NUMBER
			3714	

DATE MAILED: 11/15/2006

Please find below and/or attached an Office communication concerning this application or proceeding.



**UNITED STATES DEPARTMENT OF COMMERCE**

**U.S. Patent and Trademark Office**

Address: COMMISSIONER FOR PATENTS  
P.O. Box 1450  
Alexandria, Virginia 22313-1450

APPLICATION NO./ CONTROL NO.	FILING DATE	FIRST NAMED INVENTOR / PATENT IN REEXAMINATION	ATTORNEY DOCKET NO.
---------------------------------	-------------	---	---------------------

EXAMINER

ART UNIT	PAPER
----------	-------

20061113

DATE MAILED:

**Please find below and/or attached an Office communication concerning this application or proceeding.**

Commissioner for Patents

The IDS filed February 13, 2004 is considered by the examiner.



**JOHN M. HOTALING, II  
PRIMARY EXAMINER**



Form PTO-1449 (modified)	Application No.: 09/688,501
<b>LIST OF ART CITED BY APPLICANT</b>	Filing Date: October 16, 2000
	First Named Inventor: Shridhar P. Joshi
	Group Art Unit: 3714
	Examiner: Alex P. Rada
	Attorney Docket No.: 47079-00077USPT
Sheet 1 of 1	

**U.S. PATENT DOCUMENTS**

Examiner Initial	Ref.	Document Number	Date	Name	Class	Sub-Class	Filing Date (if Application)
	A7						
<del>RECEIVED FEB 19 2004 TECHNOLOGY CENTER 83700</del>							

**FOREIGN PATENT DOCUMENTS**

Examiner Initial	Ref.	Document Number	Date	Country	Class	Sub-Class	Translation Yes/No
AR	B1	EP 0 843 272 A1	05/20/1998	Europe	G06F	19/00	N/A
AR	B2	EP 0 829 834 A2	03/18/1998	Europe	G07F	17/32	N/A
	B3						
	B4						
	B5						
	B6						
	B7						
	B8						

**OTHER DOCUMENTS (including author, title, date, pertinent pages, etc.)**

Examiner Initial	Ref.	Document Information

EXAMINER 	DATE CONSIDERED 11-13-06
--	--------------------------

\*Examiner: Initial if citations considered, whether or not citation is in conformance with MPEP 609; draw line through citation if not in conformance and not considered. Include copy of this form with next communication to Applicant.

CHICAGO 278143v1 47079-00077



United States Patent and Trademark Office

Under Secretary of Commerce for Intellectual Property and  
Director of the United States Patent and Trademark Office  
P.O. Box 1450  
Alexandria, Virginia 22313-1450  
www.uspto.gov

JENKENS & GILCHRIST, P.C.  
225 WEST WASHINGTON  
SUITE 2600  
CHICAGO, IL 60606

Appeal No: 2007-1924  
Application: 09/688,501  
Appellant: Shridhar P. Joshi

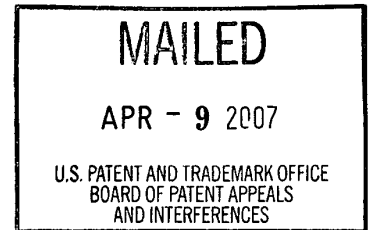

**Board of Patent Appeals and Interferences  
Docketing Notice**

Application 09/688,501 was received from the Technology Center at the Board on March 07, 2007 and has been assigned Appeal No: 2007-1924.

A review of the file indicates that the following documents have been filed by appellant:

Appeal Brief filed on: August 10, 2006  
Reply Brief filed on: NONE  
Request for Hearing filed on: NONE

In all future communications regarding this appeal, please include both the application number and the appeal number.

The mailing address for the Board is:

**BOARD OF PATENT APPEALS AND INTERFERENCES  
UNITED STATES PATENT AND TRADEMARK OFFICE  
P.O. BOX 1450  
ALEXANDRIA, VIRGINIA 22313-1450**

The facsimile number of the Board is 571-273-0052. Because of the heightened security in the Washington D.C. area, facsimile communications are recommended. Telephone inquiries can be made by calling 571-272-9797 and should be directed to a Program and Resource Administrator.

By order of the Board of Patent Appeals and Interferences





UNITED STATES PATENT AND TRADEMARK OFFICE

UNITED STATES DEPARTMENT OF COMMERCE  
United States Patent and Trademark Office  
Address: COMMISSIONER FOR PATENTS  
P.O. Box 1450  
Alexandria, Virginia 22313-1450  
www.uspto.gov

APPLICATION NUMBER	PATENT NUMBER	GROUP ART UNIT	FILE WRAPPER LOCATION
09/688,501		3714	37M1

## Correspondence Address / Fee Address Change

The following fields have been set to Customer Number 70243 on 05/03/2007

- Correspondence Address
- Maintenance Fee Address

**The address of record for Customer Number 70243 is:**

NIXON PEABODY LLP  
161 N CLARK ST.  
48TH FLOOR  
CHICAGO, IL 60601-3213

To: Scanning (Remsen Bldg.)  
From: Board of Patent Appeals  
and Interferences (BPAI)

Scanning Coversheet



Serial No. 09/688,501

Incoming \_\_\_\_\_ Date Received: \_\_\_\_\_

Outgoing  Date Mailed: 08/07/07

TOC Code: APDP

Document Name: Board Decision

Annotations: Affirmed-in-part

Note: Check box if this paper has been mailed by BPAI.

The opinion in support of the decision being entered today is *not* binding precedent  
of the Board.

UNITED STATES PATENT AND TRADEMARK OFFICE

---

BEFORE THE BOARD OF PATENT APPEALS  
AND INTERFERENCES

---

*Ex parte* SHRIDHAR P. JOSHI

---

Appeal 2007-1924  
Application 09/688,501<sup>1</sup>  
Technology Center 3700

---

Decided: August 8, 2007

---

Before JENNIFER D. BAHR, LINDA E. HORNER, and DAVID B. WALKER,  
*Administrative Patent Judges.*

WALKER, *Administrative Patent Judge.*

DECISION ON APPEAL

---

<sup>1</sup> The real party in interest is WMS Gaming, Inc. of Chicago, Illinois.

Appeal 2007-1924  
Application 09/688,501

## STATEMENT OF THE CASE

Shridhar P. Joshi (“Appellant”) seeks our review under 35 U.S.C. § 134 of the Examiner’s final rejection of claims 37-62. We have jurisdiction under 35 U.S.C. § 6(b). We affirm-in-part.<sup>2</sup>

## THE INVENTION

Appellant claims:

A remote gaming method comprising a player accessing, via a remote terminal, a gaming site on a global computer network connected to the remote terminal. The player is able to provide via the remote terminal, personal identification information to the gaming site and select, via the remote terminal, a game of chance located at a gaming establishment for remote play. The remote terminal is located outside the gaming establishment. The player places, via the remote terminal, a wager for playing the selected game and receives randomly generated text or graphical outcome data at the remote terminal for the selected game. The outcome data being generated by either a gaming server or a gaming machine at the gaming establishment and is subsequently relayed to the gaming site.

(Specification 3:5-14).

Claims 37 and 39, reproduced below, are representative of the subject matter on appeal.

37. A remote gaming method comprising:

---

<sup>2</sup> Only those arguments actually made by Appellant have been considered in this decision. Arguments which Appellant could have made but chose not to make in the Briefs have not been considered and are deemed to be waived. *See* 37 C.F.R. § 41.37(c)(1)(vii) (2004).

Appeal 2007-1924  
Application 09/688,501

accessing, via a remote terminal, a gaming site on a global computer network connected to said remote terminal;

providing, via said remote terminal, personal identification information to said gaming site;

selecting, via said remote terminal, a game of chance from a plurality of gaming machines located at a gaming establishment for remote play, said remote terminal being located outside said gaming establishment;

placing, via said remote terminal, a wager for playing said selected game; and

receiving randomly-generated text or graphical outcome data at said remote terminal for said selected game, said outcome data being generated by one of said plurality of gaming machines at said gaming establishment and relayed to said gaming site through a gaming server connected to said gaming site.

39. A method for playing a gaming machine located inside a gaming establishment from a remote terminal located outside the gaming establishment comprising:

establishing a communication link between said remote terminal and a gaming site on a global computer network, said gaming site in communication with a gaming server for collecting outcome data from gaming machines located inside the gaming establishment;

selecting a gaming machine at said gaming establishment using said remote terminal;

making a wager to play the selected gaming machine;

Appeal 2007-1924  
Application 09/688,501

receiving outcome data, including game outcome,  
at said remote terminal resulting from a play of said  
gaming machine; and

generating a payout if said game outcome meets  
predetermined criteria.

### THE REJECTIONS

The Examiner relies upon the following as evidence in support of the  
rejections:

Walker	US 6,001,016	Dec. 14, 1999
Wiltshire	US 6,409,602 B1	Jun. 25, 2002
Paravia	US 6,508,710 B1	Jan. 21, 2003

The following rejections are before us for review.

1. Claims 37-38 are rejected under 35 U.S.C. § 103(a) as unpatentable over Wiltshire in view of Paravia.
2. Claims 39-62 are rejected under 35 U.S.C. § 103(a) as unpatentable over Wiltshire in view of Walker.

### ISSUES

The issues before us are whether Appellant has shown that the Examiner erred in rejecting the following claims under 35 U.S.C. § 103(a): (1) claims 37-38 as unpatentable over Wiltshire in view of Paravia; and (2) claims 39-62 as unpatentable over Wiltshire in view of Walker. The first issue turns on whether Wiltshire or Paravia discloses selecting a game of chance from a plurality of

Appeal 2007-1924  
Application 09/688,501

gaming machines located within a gaming establishment and generating outcome data at one of a plurality of gaming machines located within the gaming establishment. The second rejection turns on whether Wiltshire or Walker discloses (1) selecting a gaming machine within a gaming establishment from a remote terminal located outside the gaming establishment; and (2) a gaming website that is in communications with a gaming server for collecting outcome data from gaming machines located inside a gaming establishment.

#### FINDINGS OF FACT

We find the following enumerated findings to be supported by at least a preponderance of the evidence. *Ethicon, Inc. v. Quigg*, 849 F.2d 1422, 1427, 7 USPQ2d 1152, 1156 (Fed. Cir. 1988) (explaining the general evidentiary standard for proceedings before the Office).

1. Wiltshire teaches a computer gaming system and method of operation wherein the gaming programs are executed entirely on a server/host computer, with only wagering input and display output operations being executed on the client/terminal computers to reduce the cost of hardware and software required for each client/terminal computer (Wiltshire, col. 2, ll. 22-51).
2. Wiltshire does not disclose selecting, via a remote terminal, a game of chance from a plurality of gaming machines located at a gaming establishment for remote play (Wiltshire, *passim*).

Appeal 2007-1924  
Application 09/688,501

3. Wiltshire also does not teach randomly generating outcome data at one of a plurality of gaming machines located within a gaming establishment (Wiltshire, *passim*).
4. Wiltshire further discloses a computer gaming system wherein a gaming server/host computer is connected to a plurality of remote client/terminal computers via network interface and communications pathways (Wiltshire, col. 3, ll. 61-66). Wiltshire teaches that the communications pathways can be any type of local area, wide area or global communication pathways, including the Internet and the World Wide Web (Wiltshire, col. 5, ll. 30-32). Wiltshire teaches that the client terminal first connects to a website to download the terminal software, installs the software on the client/terminal, and then uses the software to connect to the server/host computer (Wiltshire, col. 8, ll. 15-33).
5. Wiltshire does not teach that the website for downloading the client/terminal software is in communication with a gaming server for collecting outcome data from gaming machines located inside a gaming establishment (Wiltshire, *passim*).
6. Paravia teaches an automated gaming service for one or more players that can be implemented in a computer-based environment to allow automated computation of wagers, payouts, and other parameters (Paravia, col. 1, 60-67).



7. Paravia does not disclose selecting, via a remote terminal, a game of chance from a plurality of gaming machines located at a gaming establishment for remote play (Paravia, *passim*).
8. Paravia also does not teach randomly generating outcome data at one of a plurality of gaming machines located within a gaming establishment (Paravia, *passim*).
9. Walker teaches a method and system for remote play of a gaming device, such as a slot machine using a gaming server, a plurality of gaming devices, and a remote wagering terminal. The gaming devices are configured to generate outcome data and automatically communicate the outcome data to the gaming server, which is configured to select outcome data from at least one of the gaming devices for receipt by the remote wagering terminal (Walker, col. 2, ll. 51-59).
10. Walker teaches a remote wagering terminal that transmits the play preferences to a slot network server that stores the play preferences. Based on the play preferences, the slot network server identifies the outcome data from one or more slot machines and transmits this outcome data from those slot machines to the remote wagering terminal (Walker, col. 3, ll. 42-48).
11. Walker discloses an alternate embodiment wherein the remote wagering terminal does not make a payout but rather directs the slot network server to increment the credit balance by the amount of the payout (Walker, col. 7, ll. 60-64).

12. Walker does not teach a gaming website in communication with a gaming server for collecting outcome data from gaming machines located inside the gaming establishment (Walker, *passim*).
13. Claim 6 of Walker discloses “said step of receiving data includes receiving a slot machine type” (Walker, col. 13, ll. 11-12).
14. Claim 7 of Walker discloses “wherein said step of receiving data includes receiving player preferences” (Walker, col. 13, ll. 13-14).

#### PRINCIPLES OF LAW

“Section 103 forbids issuance of a patent when ‘the differences between the subject matter sought to be patented and the prior art are such that the subject matter as a whole would have been obvious at the time the invention was made to a person having ordinary skill in the art to which said subject matter pertains.’” *KSR Int’l Co. v. Teleflex Inc.*, 127 S.Ct. 1727, 1734, 82 USPQ2d 1385, 1391 (2007). The question of obviousness is resolved on the basis of underlying factual determinations including (1) the scope and content of the prior art, (2) any differences between the claimed subject matter and the prior art, (3) the level of skill in the art, and (4) where in evidence, so-called secondary considerations. *Graham v. John Deere Co.*, 383 U.S. 1, 17-18, 148 USPQ 459, 467 (1966). *See also KSR*, 127 S.Ct. at 1734, 82 USPQ2d at 1391 (“While the sequence of these questions might be reordered in any particular case, the [*Graham*] factors continue to define the inquiry that controls.”).

In rejecting claims under 35 U.S.C. § 103(a), the examiner bears the initial

Appeal 2007-1924  
Application 09/688,501

burden of establishing a prima facie case of obviousness. *In re Oetiker*, 977 F.2d 1443, 1445, 24 USPQ2d 1443, 1444 (Fed. Cir. 1992). *See also In re Piasecki*, 745 F.2d 1468, 1472, 223 USPQ 785, 788 (Fed. Cir. 1984). Only if this initial burden is met does the burden of coming forward with evidence or argument shift to the appellant. *Id.* at 1445, 24 USPQ2d at 1444. *See also Piasecki*, 745 F.2d at 1472, 223 USPQ at 788. Obviousness is then determined on the basis of the evidence as a whole and the relative persuasiveness of the arguments. *See Oetiker*, 977 F.2d at 1445, 24 USPQ2d at 1444; *Piasecki*, 745 F.2d at 1472, 223 USPQ at 788.

#### ANALYSIS

##### **A. Rejection of claims 37-38 under 35 U.S.C. § 103(a) as unpatentable over Wiltshire in view of Paravia.**

Contrary to the findings of the Examiner, Wiltshire discloses neither selecting a game of chance from a plurality of gaming machines located within a gaming establishment nor generating outcome data at one of a plurality of gaming machines located within a gaming establishment (Findings of Fact 2-3). The Examiner's reference to Figures 4B-9D of Wiltshire does not meet the missing limitations, because the displayed gaming machines are virtual machines and the gaming programs are executed entirely on a server/host computer (Finding of Fact 1). Paravia also fails to teach the missing limitations. The Examiner has provided no reference showing the missing limitations, nor has he made a prima facie case of obviousness of claims 37-38 over Wiltshire in view of Paravia.

**B. Rejection of claims 39-62 under 35 U.S.C. § 103(a) as unpatentable over Wiltshire in view of Walker.**

Appellant argues that the rejection of independent claims 39, 52, and 62 is improper because “Wiltshire and Walker fail to teach or suggest selecting a gaming machine within a gaming establishment from ‘a remote terminal located outside the gaming establishment.’” (Br. 16). Wiltshire teaches accessing a game server which runs gaming programs from a remote terminal, but does not disclose selecting a gaming machine within a gaming establishment from a remote terminal located outside the gaming establishment (Findings of Fact 1-2). Walker teaches entering play preferences at a remote wagering terminal that are used by a slot network server to select one or more slot machines (Finding of Fact 10).

Appellant argues that Walker appears to teach that “the remote wagering terminal is located right there on the premises of the gaming establishment.” (Br. 17) The Appellant relies in part on the fact that Walker discloses coin hoppers with each slot machine that would be difficult to service if the remote wagering terminals were not located in the gambling establishment (Br. 17). However, Walker also discloses an alternate embodiment wherein the remote wagering terminal does not make a payout but rather directs the slot network server to increment the credit balance by the amount of the payout (Finding of Fact 11). Walker does not explicitly limit the location of the remote wagering terminal to the gaming establishment, and its name at least implies the contrary. Moreover, Wiltshire teaches remote client/terminals that would meet the remote terminal limitation of claims 39, 52, and 62.

Appeal 2007-1924  
Application 09/688,501

Appellant also argues that the rejection of claims 39, 52, and 62 is improper because “Wiltshire and Walker fail to teach or suggest ‘relaying outcome data’ through a gaming site” (Br. 17). Appellant is correct, but only as to claim 39, because the disputed limitation does not appear in the language of claims 52 or 62. Wiltshire discloses a website for downloading client/terminal software, but does not teach that the website is in communication with a gaming server for collecting outcome data from gaming machines located inside a gaming establishment as required by independent claim 39 (Findings of Fact 4-5). Walker does not correct that deficiency (Finding of Fact 12). The Examiner has provided no reference showing the missing limitation, nor has he made a prima facie case of obviousness over Wiltshire in view of Walker with respect to claim 39 and its dependent claims, 40-51.

Because the disputed claim limitation is not present in claims 52 and 62, Appellant has not shown that the Examiner erred in rejecting claims 52 and 62. Moreover, because Appellant separately argues only claims 56 and 57, claims 53-55 and 58-61 fall with claim 52. *See* 37 C.F.R. § 41.37(c)(1)(vii). *See also In re Young*, 927 F.2d 588, 590, 18 USPQ2d 1089, 1091 (Fed. Cir. 1991).

Appellant argues that “Walker fails to teach or suggest outcome data that includes a ‘gaming machine type,’ as required by claims 46 and 56.” (Br. 18). Appellant misstates the language of claim 56, which actually requires that “said operation of receiving information includes receiving a gaming machine type” (Br. Claim Appendix 6). In fact, claim 6 of Walker discloses “said step of receiving data includes receiving a slot machine type,” (Finding of Fact 13), which meets the

Appeal 2007-1924  
Application 09/688,501

limitation of claim 56 of “receiving a gaming machine type.” Appellant has not shown that the Examiner erred in rejecting claim 56.

Appellant further argues that “Walker fails to teach or suggest outcome data that includes ‘player preferences’ as required by claims 47 and 57.” (Br. 19). Appellant misstates the language of claim 57, which actually requires that “said operation of receiving information includes receiving player preferences” (Br. Claim Appendix 6). In fact, claim 7 of Walker discloses “wherein said step of receiving data includes receiving player preferences,” (Finding of Fact 14), which meets the disputed limitation of claim 57. Appellant has not shown that the Examiner erred in rejecting claim 57.

#### CONCLUSIONS

We conclude that Appellant has shown that the Examiner erred in rejecting claims 37-51 under 35 U.S.C. § 103(a), but has not shown that the Examiner erred in rejecting claims 52-62 under 35 U.S.C. § 103(a).

#### DECISION

The decision of the Examiner to reject claims 37-51 under 35 U.S.C. § 103(a) is reversed. The decision of the Examiner to reject claims 52-62 under 35 U.S.C. § 103(a) is affirmed.

Appeal 2007-1924  
Application 09/688,501

No time period for taking any subsequent action in connection with this appeal may be extended under 37 C.F.R. § 1.136(a). *See* 37 C.F.R. § 1.136(a)(1)(iv) (2006).

AFFIRMED-IN-PART

JRG

NIXON PEABODY LLP  
161 N CLARK ST.  
48TH FLOOR  
CHICAGO, IL 60601-3213



IN THE UNITED STATES PATENT AND TRADEMARK OFFICE

Application No. : 09/688,501  
 Applicants : Shridhar P. Joshi  
 Filed : October 16, 2000  
 Title : METHOD OF TRANSFERRING GAMING DATA ON A  
 GLOBAL COMPUTER NETWORK  
 TC/A.U. : 3714  
 Examiner : Alex P. Rada  
 Docket No. : 247079-00077USPT  
 Customer No. : 70243

MS Amendment  
 Commissioner for Patents  
 P.O. Box 1450  
 Alexandria, VA 22313-1450

**CERTIFICATE OF MAILING**

I hereby certify that this correspondence is being deposited with the United States Postal Service as first class mail, postage prepaid, in an envelope addressed to the MS Amendment, Commissioner for Patents, P.O. Box 1450, Alexandria, VA 22313-1450, on October 9, 2007.

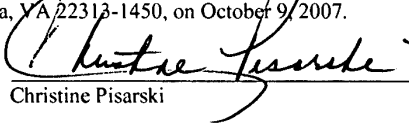
Signature:   
Christine Pisarski

**AMENDMENT AND RESPONSE TO BOARD DECISION DATED AUGUST 8, 2007**

Dear Sir:

This is in response to the Office Action dated August 8, 2007. The shortened statutory period for response is two months from the mailing date, i.e., by October 8, 2007, and this response is being filed on October 9, 2007, because October 8, 2007 is a federal holiday. Please enter the following amendments and remarks into the record for this application.

Amendments to the claims are reflected in the listing of claims which begins on page 2 of this paper.

Remarks/Arguments begin on page 6 of this paper.



**Listing of Claims:**

This listing of claims will replace all prior versions, and listing, of claims in the application.

Claims 1-36. (Cancelled)

37. (Previously Presented) A remote gaming method comprising:
- accessing, via a remote terminal, a gaming site on a global computer network connected to said remote terminal;
  - providing, via said remote terminal, personal identification information to said gaming site;
  - selecting, via said remote terminal, a game of chance from a plurality of gaming machines located at a gaming establishment for remote play, said remote terminal being located outside said gaming establishment;
  - placing, via said remote terminal, a wager for playing said selected game; and
  - receiving randomly-generated text or graphical outcome data at said remote terminal for said selected game, said outcome data being generated by one of said plurality of gaming machines at said gaming establishment and relayed to said gaming site through a gaming server connected to said gaming site.

38. (Previously Presented) A remote gaming method using a gaming server, a remote terminal, and a gaming site on a global computer network, said gaming server being located at a gaming establishment, said remote terminal being located outside said gaming establishment, said gaming site being provided on said global computer network, the method comprising:

receiving, at said gaming server, personal identification information, game selection information, and wager information from a player accessing said gaming site via said remote terminal, said remote terminal being connected to said global computer network;

randomly generating outcome data at one of a plurality of gaming machines communicatively coupled to said gaming server, said outcome data being generated for a game selected according to said game selection information, said plurality of gaming machines being located at said gaming establishment;

receiving said outcome data at said gaming server; and

transmitting said outcome data from said gaming server to said gaming site for display to said player on said remote terminal in text or graphical form.

39. (Previously Presented) A method for playing a gaming machine located inside a gaming establishment from a remote terminal located outside the gaming establishment comprising:

establishing a communication link between said remote terminal and a gaming site on a global computer network, said gaming site in communication with a gaming server for collecting outcome data from gaming machines located inside the gaming establishment;

selecting a gaming machine at said gaming establishment using said remote terminal;

making a wager to play the selected gaming machine;

receiving outcome data, including game outcome, at said remote terminal resulting from a play of said gaming machine; and

generating a payout if said game outcome meets predetermined criteria.

40. (Previously Presented) The method of claim 39 wherein said outcome data comprises information identifying the value of said payout; and further comprising the step of using said payout information to simulate a display of said game outcome at said remote location.

41. (Previously Presented) The method of claim 39 further comprising using said outcome data to simulate a display of said game outcome on said remote terminal.

42. (Previously Presented) The method of claim 39, wherein said selected gaming machine comprises a slot machine and wherein said game outcome data includes a reel position.

43. (Previously Presented) The method of claim 39 wherein said selected gaming machine comprises a video poker machine including a display for displaying a poker hand.

44. (Previously Presented) The method of claim 39 wherein said step of receiving outcome data includes receiving outcome data from a plurality of gaming machines for remote play.

45. (Previously Presented) The method of claim 44 wherein said step of receiving outcome data includes receiving a gaming machine identifier.

46. (Previously Presented) The method of claim 44 wherein said step of receiving outcome data includes receiving a gaming machine type.

47. (Previously Presented) The method of claim 44 wherein said step of receiving outcome data includes receiving player preferences.

48. (Previously Presented) The method of claim 39 wherein said selected gaming machine comprises a slot machine and wherein said game outcome comprises information identifying a reel position of said gaming machine; and further comprising the step of using said outcome information to display said reel position on said remote terminal.

49. (Previously Presented) The method of claim 39 and further including the steps of receiving a player identifier; and transmitting said player identifier for identification of said player.

50. (Previously Presented) The method of claim 39 wherein said game outcome results from the server initiating game play on the selected gaming machine.

51. (Previously Presented) The method of claim 39 wherein said game outcome results from the manual game play on the selected gaming machine.

Claims 52-62. (Cancelled)

Application No. 09/688,501  
Amendment and Response To Board Decision Dated August 8, 2007

### **REMARKS/ARGUMENTS**

Claims 37-51 remain in the application for further prosecution. No claims have been amended. Claims 52-62 have been canceled.

#### **Previous Rejections under 35 USC § 103(a)**

Claims 37-38 are rejected under 35 U.S.C. § 103(a) as unpatentable over U.S. Patent No. 6,409,602 (Wiltshire) in view of U.S. Patent No. 6,508,710 (Paravia).

Claims 39-62 are rejected under 35 U.S.C. § 103(a) as unpatentable over U.S. Patent No. 6,409,602 (Wiltshire) in view of U.S. Patent No. 6,001,016 (Walker).

Those rejections were appealed.

#### **Decision of the Board of Appeals Dated August 8, 2007**

The Board reversed the Examiner's rejection of claims 37-51. However, the Board affirmed the Examiner's rejection of claims 52-62.

Applicants have now canceled Claims 52-62. Accordingly, the Applicant's respectfully request that a Notice of Allowance be issued in this matter with regard to pending claims 37-51.

Application No. 09/688,501  
Amendment and Response To Board Decision Dated August 8, 2007

**Conclusion**

It is the Applicants' belief that all of the claims are now in condition for allowance and action towards that effect is respectfully requested.

If there are any matters which may be resolved or clarified through a telephone interview, the Examiner is requested to contact the undersigned attorney at the number indicated. It is believed that no fees are presently due; however, should any additional fees be required (except for payment of the issue fee), the Commissioner is authorized to deduct the fees from Nixon Peabody Deposit Account No. 50-4181, Order No. 247079-00077USPT.

Respectfully submitted,

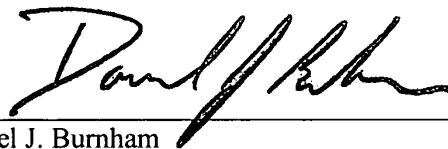

Date: October 9, 2007

---

Daniel J. Burnham  
Reg. No. 39,618  
NIXON PEABODY LLP  
161 North Clark Street., 48<sup>th</sup> Floor  
Chicago, Illinois 60601-3213  
(312) 425-3900 (Telephone)  
(312) 425-3909 (Facsimile)  
Attorney for Applicants



JAW

### AMENDMENT TRANSMITTAL LETTER

Docket No.  
247079-00077USPT

Application No.  
09/688501

Filing Date  
October 16, 2000

Examiner  
Alex P. Rada

Art Unit  
3225

Applicant(s): Shridhar P. Joshi

Invention: METHOD OF TRANSFERRING GAMING DATA ON A GLOBAL COMPUTER NETWORK

#### TO THE COMMISSIONER FOR PATENTS

Transmitted herewith is an amendment in the above-identified application.  
The fee has been calculated and is transmitted as shown below.

CLAIMS AS AMENDED						
	Claims Remaining After Amendment	Highest Number Previously Paid	Number Extra Claims Present	Rate		
Total Claims	15	- 26 =	0	x	50.00	0.00
Independent Claims	3	- 5 =	0	x	200.00	0.00
Multiple Dependent Claims (check if applicable) <input type="checkbox"/>						
Other fee (please specify):						
<b>TOTAL ADDITIONAL FEE FOR THIS AMENDMENT:</b>						0.00

- Large Entity  Small Entity
- No additional fee is required for this amendment.
- Please charge Deposit Account No. \_\_\_\_\_ in the amount of \$ \_\_\_\_\_.  
A duplicate copy of this sheet is enclosed.
- A check in the amount of \$ \_\_\_\_\_ to cover the filing fee is enclosed.
- Payment by credit card. Form PTO-2038 is attached.
- The Director is hereby authorized to charge and credit Deposit Account No. 50-4181  
as described below. A duplicate copy of this sheet is enclosed.
- Credit any overpayment.
- Charge any additional filing or application processing fees required under 37 CFR 1.16 and 1.17.

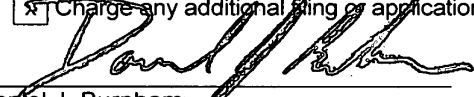
  
 Daniel J. Burnham  
 Attorney Reg. No.: 39,618

Dated: October 9, 2007

NIXON PEABODY, LLP.  
 161 North Clark Street., 48<sup>th</sup> Floor  
 Chicago, Illinois 60601-3213  
 (312) 425-3900

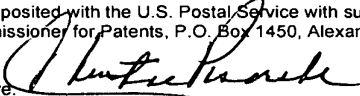
I hereby certify that this correspondence is being deposited with the U.S. Postal Service with sufficient postage as First Class Mail, in an envelope addressed to: MS Amendment, Commissioner for Patents, P.O. Box 1450, Alexandria, VA 22313-1450, on the date shown below.  
 Dated: October 9, 2007  
 Signature:  (Christine Pisarski)



Application No. 09/688,501

Attorney Docket No.: 247079-00077USPT

## Certificate of Mailing Under 37 CFR 1.8

I hereby certify that this correspondence is being deposited with the United States Postal Service with sufficient postage as **First Class Mail** in an envelope addressed to:

Commissioner for Patents  
MS Amendments  
P.O. Box 1450  
Alexandria, VA 22313-1450

on October 9, 2007  
Date

Signature

Christine Pisarski

Typed or printed name of person signing Certificate

N/A  
Registration Number, if applicable

(312) 425-3900  
Telephone Number

Note: Each paper must have its own certificate of mailing, or this certificate must identify each submitted paper.

1. Amendment and Response to Board Decision Dated August 8, 2007 (7 pgs);
2. Amendment Transmittal (in duplicate (2 pgs);
3. Certificate of Mailing (1 pg); and
4. Acknowledgement Postcard



Under the Paperwork Reduction Act of 1995, no persons are required to respond to a collection of information unless it displays a valid OMB control number.

<b>PATENT APPLICATION FEE DETERMINATION RECORD</b> Substitute for Form PTO-875					Application or Docket Number <b>09/688,501</b>		Filing Date <b>10/16/2000</b>		<input type="checkbox"/> To be Mailed						
<b>APPLICATION AS FILED – PART I</b>															
(Column 1)			(Column 2)			SMALL ENTITY <input type="checkbox"/>		OR			OTHER THAN SMALL ENTITY				
FOR		NUMBER FILED	NUMBER EXTRA		RATE (\$)	FEE (\$)	OR		RATE (\$)	FEE (\$)					
<input type="checkbox"/> BASIC FEE <small>(37 CFR 1.16(a), (b), or (c))</small>		N/A	N/A		N/A				N/A						
<input type="checkbox"/> SEARCH FEE <small>(37 CFR 1.16(k), (i), or (m))</small>		N/A	N/A		N/A		N/A								
<input type="checkbox"/> EXAMINATION FEE <small>(37 CFR 1.16(o), (p), or (q))</small>		N/A	N/A		N/A		N/A								
TOTAL CLAIMS <small>(37 CFR 1.16(i))</small>		minus 20 =	*		X \$ =		OR		X \$ =						
INDEPENDENT CLAIMS <small>(37 CFR 1.16(h))</small>		minus 3 =	*		X \$ =		OR		X \$ =						
<input type="checkbox"/> APPLICATION SIZE FEE <small>(37 CFR 1.16(s))</small>		If the specification and drawings exceed 100 sheets of paper, the application size fee due is \$250 (\$125 for small entity) for each additional 50 sheets or fraction thereof. See 35 U.S.C. 41(a)(1)(G) and 37 CFR 1.16(s).													
<input type="checkbox"/> MULTIPLE DEPENDENT CLAIM PRESENT <small>(37 CFR 1.16(j))</small>															
* If the difference in column 1 is less than zero, enter "0" in column 2.															
<b>APPLICATION AS AMENDED – PART II</b>										SMALL ENTITY		OR		OTHER THAN SMALL ENTITY	
(Column 1)			(Column 2)			(Column 3)			SMALL ENTITY		OR		OTHER THAN SMALL ENTITY		
AMENDMENT	<b>10/15/2007</b>	CLAIMS REMAINING AFTER AMENDMENT		HIGHEST NUMBER PREVIOUSLY PAID FOR	PRESENT EXTRA	RATE (\$)	ADDITIONAL FEE (\$)		RATE (\$)	ADDITIONAL FEE (\$)					
	Total <small>(37 CFR 1.16(o))</small>	* 15	Minus	** 39	= 0	X \$ =		OR	X \$50=	0					
	Independent <small>(37 CFR 1.16(h))</small>	* 3	Minus	***8	= 0	X \$ =		OR	X \$210=	0					
	<input type="checkbox"/> Application Size Fee <small>(37 CFR 1.16(s))</small>														
	<input type="checkbox"/> FIRST PRESENTATION OF MULTIPLE DEPENDENT CLAIM <small>(37 CFR 1.16(j))</small>														
						TOTAL ADD'L FEE		OR	TOTAL ADD'L FEE	0					
AMENDMENT		CLAIMS REMAINING AFTER AMENDMENT		HIGHEST NUMBER PREVIOUSLY PAID FOR	PRESENT EXTRA	RATE (\$)	ADDITIONAL FEE (\$)		RATE (\$)	ADDITIONAL FEE (\$)					
	Total <small>(37 CFR 1.16(o))</small>	*	Minus	**	=	X \$ =		OR	X \$ =						
	Independent <small>(37 CFR 1.16(h))</small>	*	Minus	***	=	X \$ =		OR	X \$ =						
	<input type="checkbox"/> Application Size Fee <small>(37 CFR 1.16(s))</small>														
	<input type="checkbox"/> FIRST PRESENTATION OF MULTIPLE DEPENDENT CLAIM <small>(37 CFR 1.16(j))</small>														
						TOTAL ADD'L FEE		OR	TOTAL ADD'L FEE						
* If the entry in column 1 is less than the entry in column 2, write "0" in column 3.															
** If the "Highest Number Previously Paid For" IN THIS SPACE is less than 20, enter "20".															
*** If the "Highest Number Previously Paid For" IN THIS SPACE is less than 3, enter "3".															
The "Highest Number Previously Paid For" (Total or Independent) is the highest number found in the appropriate box in column 1.															
Legal Instrument Examiner: Brenda Webb															

This collection of information is required by 37 CFR 1.16. The information is required to obtain or retain a benefit by the public which is to file (and by the USPTO to process) an application. Confidentiality is governed by 35 U.S.C. 122 and 37 CFR 1.14. This collection is estimated to take 12 minutes to complete, including gathering, preparing, and submitting the completed application form to the USPTO. Time will vary depending upon the individual case. Any comments on the amount of time you require to complete this form and/or suggestions for reducing this burden, should be sent to the Chief Information Officer, U.S. Patent and Trademark Office, U.S. Department of Commerce, P.O. Box 1450, Alexandria, VA 22313-1450. DO NOT SEND FEES OR COMPLETED FORMS TO THIS ADDRESS. **SEND TO: Commissioner for Patents, P.O. Box 1450, Alexandria, VA 22313-1450.**

If you need assistance in completing the form, call 1-800-PTO-9199 and select option 2.

## EAST Search History

Ref #	Hits	Search Query	DBs	Default Operator	Plurals	Time Stamp
L1	7914	(463/16-25,29,40-42).CCLS.	US-PGPUB; USPAT; USOCR	OR	OFF	2007/10/25 16:16
L2	3161455	@ad<="20001016"	US-PGPUB; USPAT; USOCR	OR	ON	2007/10/25 16:16
L3	1845	1 and 2	US-PGPUB; USPAT; USOCR	OR	ON	2007/10/25 16:26
L8	0	((remote with terminal) and (gam\$3 with site) and (casino establishment) and (personal with identification) and server and wager and game and network).clm.	US-PGPUB; USPAT; USOCR	OR	ON	2007/10/25 16:22
L9	0	((remote with terminal) and (gam\$3 with site) and (casino establishment) and (personal with identification) and server and wager and (gam\$3 with machine) and network).clm.	US-PGPUB; USPAT; USOCR	OR	ON	2007/10/25 16:23
L10	0	3 and ((remote with terminal) and (gam\$3 with site) and (casino establishment) and (personal with identification) and server and wager and (gam\$3 with machine) and network).clm.	US-PGPUB; USPAT; USOCR	OR	ON	2007/10/25 16:26
L11	3543	(463/16,42).CCLS.	US-PGPUB; USPAT; USOCR	OR	OFF	2007/10/25 16:26
L12	742	11 and 2	US-PGPUB; USPAT; USOCR	OR	ON	2007/10/25 16:26
L13	0	12 and ((remote with terminal) and (gam\$3 with site) and (casino establishment) and (personal with identification) and server and wager and (gam\$3 with machine) and network).clm.	US-PGPUB; USPAT; USOCR	OR	ON	2007/10/25 16:26



UNITED STATES PATENT AND TRADEMARK OFFICE

UNITED STATES DEPARTMENT OF COMMERCE
United States Patent and Trademark Office
Address: COMMISSIONER FOR PATENTS
P.O. Box 1450
Alexandria, Virginia 22313-1450
www.uspto.gov

NOTICE OF ALLOWANCE AND FEE(S) DUE

70243 7590 11/08/2007
NIXON PEABODY LLP
161 N CLARK ST.
48TH FLOOR
CHICAGO, IL 60601-3213

EXAMINER
RADA, ALEX P

ART UNIT PAPER NUMBER
3714

DATE MAILED: 11/08/2007

Table with 5 columns: APPLICATION NO., FILING DATE, FIRST NAMED INVENTOR, ATTORNEY DOCKET NO., CONFIRMATION NO.
09/688,501 10/16/2000 Shridhar P. Joshi 47079-00077 3225

TITLE OF INVENTION: METHOD OF TRANSFERRING GAMING DATA ON A GLOBAL COMPUTER NETWORK

Table with 7 columns: APPLN. TYPE, SMALL ENTITY, ISSUE FEE DUE, PUBLICATION FEE DUE, PREV. PAID ISSUE FEE, TOTAL FEE(S) DUE, DATE DUE
nonprovisional NO \$1440 \$0 \$0 \$1440 02/08/2008

THE APPLICATION IDENTIFIED ABOVE HAS BEEN EXAMINED AND IS ALLOWED FOR ISSUANCE AS A PATENT. PROSECUTION ON THE MERITS IS CLOSED. THIS NOTICE OF ALLOWANCE IS NOT A GRANT OF PATENT RIGHTS. THIS APPLICATION IS SUBJECT TO WITHDRAWAL FROM ISSUE AT THE INITIATIVE OF THE OFFICE OR UPON PETITION BY THE APPLICANT. SEE 37 CFR 1.313 AND MPEP 1308.

THE ISSUE FEE AND PUBLICATION FEE (IF REQUIRED) MUST BE PAID WITHIN THREE MONTHS FROM THE MAILING DATE OF THIS NOTICE OR THIS APPLICATION SHALL BE REGARDED AS ABANDONED. THIS STATUTORY PERIOD CANNOT BE EXTENDED. SEE 35 U.S.C. 151. THE ISSUE FEE DUE INDICATED ABOVE DOES NOT REFLECT A CREDIT FOR ANY PREVIOUSLY PAID ISSUE FEE IN THIS APPLICATION. IF AN ISSUE FEE HAS PREVIOUSLY BEEN PAID IN THIS APPLICATION (AS SHOWN ABOVE), THE RETURN OF PART B OF THIS FORM WILL BE CONSIDERED A REQUEST TO REAPPLY THE PREVIOUSLY PAID ISSUE FEE TOWARD THE ISSUE FEE NOW DUE.

HOW TO REPLY TO THIS NOTICE:

I. Review the SMALL ENTITY status shown above.

If the SMALL ENTITY is shown as YES, verify your current SMALL ENTITY status:

- A. If the status is the same, pay the TOTAL FEE(S) DUE shown above.
B. If the status above is to be removed, check box 5b on Part B - Fee(s) Transmittal and pay the PUBLICATION FEE (if required) and twice the amount of the ISSUE FEE shown above, or

If the SMALL ENTITY is shown as NO:

- A. Pay TOTAL FEE(S) DUE shown above, or
B. If applicant claimed SMALL ENTITY status before, or is now claiming SMALL ENTITY status, check box 5a on Part B - Fee(s) Transmittal and pay the PUBLICATION FEE (if required) and 1/2 the ISSUE FEE shown above.

II. PART B - FEE(S) TRANSMITTAL, or its equivalent, must be completed and returned to the United States Patent and Trademark Office (USPTO) with your ISSUE FEE and PUBLICATION FEE (if required). If you are charging the fee(s) to your deposit account, section "4b" of Part B - Fee(s) Transmittal should be completed and an extra copy of the form should be submitted. If an equivalent of Part B is filed, a request to reapply a previously paid issue fee must be clearly made, and delays in processing may occur due to the difficulty in recognizing the paper as an equivalent of Part B.

III. All communications regarding this application must give the application number. Please direct all communications prior to issuance to Mail Stop ISSUE FEE unless advised to the contrary.

IMPORTANT REMINDER: Utility patents issuing on applications filed on or after Dec. 12, 1980 may require payment of maintenance fees. It is patentee's responsibility to ensure timely payment of maintenance fees when due.

**PART B - FEE(S) TRANSMITTAL**

Complete and send this form, together with applicable fee(s), to: **Mail** **Mail Stop ISSUE FEE**  
**Commissioner for Patents**  
**P.O. Box 1450**  
**Alexandria, Virginia 22313-1450**  
 or **Fax** **(571)-273-2885**

**INSTRUCTIONS:** This form should be used for transmitting the ISSUE FEE and PUBLICATION FEE (if required). Blocks 1 through 5 should be completed where appropriate. All further correspondence including the Patent, advance orders and notification of maintenance fees will be mailed to the current correspondence address as indicated unless corrected below or directed otherwise in Block 1, by (a) specifying a new correspondence address; and/or (b) indicating a separate "FEE ADDRESS" for maintenance fee notifications.

CURRENT CORRESPONDENCE ADDRESS (Note: Use Block 1 for any change of address)

Note: A certificate of mailing can only be used for domestic mailings of the Fee(s) Transmittal. This certificate cannot be used for any other accompanying papers. Each additional paper, such as an assignment or formal drawing, must have its own certificate of mailing or transmission.

70243                      7590                      11/08/2007  
**NIXON PEABODY LLP**  
 161 N CLARK ST.  
 48TH FLOOR  
 CHICAGO, IL 60601-3213

**Certificate of Mailing or Transmission**  
 I hereby certify that this Fee(s) Transmittal is being deposited with the United States Postal Service with sufficient postage for first class mail in an envelope addressed to the Mail Stop ISSUE FEE address above, or being facsimile transmitted to the USPTO (571) 273-2885, on the date indicated below.

_____	(Depositor's name)
_____	(Signature)
_____	(Date)

APPLICATION NO.	FILING DATE	FIRST NAMED INVENTOR	ATTORNEY DOCKET NO.	CONFIRMATION NO.
09/688,501	10/16/2000	Shridhar P. Joshi	47079-00077	3225

TITLE OF INVENTION: METHOD OF TRANSFERRING GAMING DATA ON A GLOBAL COMPUTER NETWORK

APPLN. TYPE	SMALL ENTITY	ISSUE FEE DUE	PUBLICATION FEE DUE	PREV. PAID ISSUE FEE	TOTAL FEE(S) DUE	DATE DUE
nonprovisional	NO	\$1440	\$0	\$0	\$1440	02/08/2008

EXAMINER	ART UNIT	CLASS-SUBCLASS
RADA, ALEX P	3714	463-042000

1. Change of correspondence address or indication of "Fee Address" (37 CFR 1.363). <input type="checkbox"/> Change of correspondence address (or Change of Correspondence Address form PTO/SB/122) attached. <input type="checkbox"/> "Fee Address" indication (or "Fee Address" Indication form PTO/SB/47; Rev 03-02 or more recent) attached. Use of a Customer Number is required.	2. For printing on the patent front page, list (1) the names of up to 3 registered patent attorneys or agents OR, alternatively, _____ 1 (2) the name of a single firm (having as a member a registered attorney or agent) and the names of up to 2 registered patent attorneys or agents. If no name is listed, no name will be printed. _____ 2 _____ 3
---	--

3. ASSIGNEE NAME AND RESIDENCE DATA TO BE PRINTED ON THE PATENT (print or type)

PLEASE NOTE: Unless an assignee is identified below, no assignee data will appear on the patent. If an assignee is identified below, the document has been filed for recordation as set forth in 37 CFR 3.11. Completion of this form is NOT a substitute for filing an assignment.

(A) NAME OF ASSIGNEE \_\_\_\_\_ (B) RESIDENCE: (CITY and STATE OR COUNTRY) \_\_\_\_\_

Please check the appropriate assignee category or categories (will not be printed on the patent) :  Individual  Corporation or other private group entity  Government

4a. The following fee(s) are submitted: <input type="checkbox"/> Issue Fee <input type="checkbox"/> Publication Fee (No small entity discount permitted) <input type="checkbox"/> Advance Order - # of Copies _____	4b. Payment of Fee(s): (Please first reapply any previously paid issue fee shown above) <input type="checkbox"/> A check is enclosed. <input type="checkbox"/> Payment by credit card. Form PTO-2038 is attached. <input type="checkbox"/> The Director is hereby authorized to charge the required fee(s), any deficiency, or credit any overpayment, to Deposit Account Number _____ (enclose an extra copy of this form).
--	---

5. Change in Entity Status (from status indicated above)

a. Applicant claims SMALL ENTITY status. See 37 CFR 1.27.  b. Applicant is no longer claiming SMALL ENTITY status. See 37 CFR 1.27(g)(2).

NOTE: The Issue Fee and Publication Fee (if required) will not be accepted from anyone other than the applicant; a registered attorney or agent, or the assignee or other party in interest as shown by the records of the United States Patent and Trademark Office.

Authorized Signature \_\_\_\_\_ Date \_\_\_\_\_  
 Typed or printed name \_\_\_\_\_ Registration No. \_\_\_\_\_

This collection of information is required by 37 CFR 1.311. The information is required to obtain or retain a benefit by the public which is to file (and by the USPTO to process) an application. Confidentiality is governed by 35 U.S.C. 122 and 37 CFR 1.14. This collection is estimated to take 12 minutes to complete, including gathering, preparing, and submitting the completed application form to the USPTO. Time will vary depending upon the individual case. Any comments on the amount of time you require to complete this form and/or suggestions for reducing this burden, should be sent to the Chief Information Officer, U.S. Patent and Trademark Office, U.S. Department of Commerce, P.O. Box 1450, Alexandria, Virginia 22313-1450. DO NOT SEND FEES OR COMPLETED FORMS TO THIS ADDRESS. SEND TO: Commissioner for Patents, P.O. Box 1450, Alexandria, Virginia 22313-1450.

Under the Paperwork Reduction Act of 1995, no persons are required to respond to a collection of information unless it displays a valid OMB control number.



UNITED STATES PATENT AND TRADEMARK OFFICE

UNITED STATES DEPARTMENT OF COMMERCE
United States Patent and Trademark Office
Address: COMMISSIONER FOR PATENTS
P.O. Box 1450
Alexandria, Virginia 22313-1450
www.uspto.gov

Table with 5 columns: APPLICATION NO., FILING DATE, FIRST NAMED INVENTOR, ATTORNEY DOCKET NO., CONFIRMATION NO.
09/688,501 10/16/2000 Shridhar P. Joshi 47079-00077 3225

70243 7590 11/08/2007
NIXON PEABODY LLP
161 N CLARK ST.
48TH FLOOR
CHICAGO, IL 60601-3213

EXAMINER

RADA, ALEX P

ART UNIT PAPER NUMBER

3714

DATE MAILED: 11/08/2007

Determination of Patent Term Adjustment under 35 U.S.C. 154 (b)
(application filed on or after May 29, 2000)

The Patent Term Adjustment to date is 551 day(s). If the issue fee is paid on the date that is three months after the mailing date of this notice and the patent issues on the Tuesday before the date that is 28 weeks (six and a half months) after the mailing date of this notice, the Patent Term Adjustment will be 551 day(s).

If a Continued Prosecution Application (CPA) was filed in the above-identified application, the filing date that determines Patent Term Adjustment is the filing date of the most recent CPA.

Applicant will be able to obtain more detailed information by accessing the Patent Application Information Retrieval (PAIR) WEB site (http://pair.uspto.gov).

Any questions regarding the Patent Term Extension or Adjustment determination should be directed to the Office of Patent Legal Administration at (571)-272-7702. Questions relating to issue and publication fee payments should be directed to the Customer Service Center of the Office of Patent Publication at 1-(888)-786-0101 or (571)-272-4200.

10

<b>Notice of Allowability</b>	<b>Application No.</b>	<b>Applicant(s)</b>	
	09/688,501	JOSHI, SHRIDHAR P.	
	<b>Examiner</b>	<b>Art Unit</b>	
	Alex P. Rada	3714	

**-- The MAILING DATE of this communication appears on the cover sheet with the correspondence address--**

All claims being allowable, PROSECUTION ON THE MERITS IS (OR REMAINS) CLOSED in this application. If not included herewith (or previously mailed), a Notice of Allowance (PTOL-85) or other appropriate communication will be mailed in due course. **THIS NOTICE OF ALLOWABILITY IS NOT A GRANT OF PATENT RIGHTS.** This application is subject to withdrawal from issue at the initiative of the Office or upon petition by the applicant. See 37 CFR 1.313 and MPEP 1308.

- 1.  This communication is responsive to 10/15/07.
  - 2.  The allowed claim(s) is/are 37-51.
  - 3.  Acknowledgment is made of a claim for foreign priority under 35 U.S.C. § 119(a)-(d) or (f).
    - a)  All    b)  Some\*    c)  None    of the:
    - 1.  Certified copies of the priority documents have been received.
    - 2.  Certified copies of the priority documents have been received in Application No. \_\_\_\_\_.
    - 3.  Copies of the certified copies of the priority documents have been received in this national stage application from the International Bureau (PCT Rule 17.2(a)).
- \* Certified copies not received: \_\_\_\_\_.

Applicant has THREE MONTHS FROM THE "MAILING DATE" of this communication to file a reply complying with the requirements noted below. Failure to timely comply will result in ABANDONMENT of this application. **THIS THREE-MONTH PERIOD IS NOT EXTENDABLE.**

- 4.  A SUBSTITUTE OATH OR DECLARATION must be submitted. Note the attached EXAMINER'S AMENDMENT or NOTICE OF INFORMAL PATENT APPLICATION (PTO-152) which gives reason(s) why the oath or declaration is deficient.
  - 5.  CORRECTED DRAWINGS ( as "replacement sheets") must be submitted.
    - (a)  including changes required by the Notice of Draftsperson's Patent Drawing Review ( PTO-948) attached
      - 1)  hereto or 2)  to Paper No./Mail Date \_\_\_\_\_.
    - (b)  including changes required by the attached Examiner's Amendment / Comment or in the Office action of Paper No./Mail Date \_\_\_\_\_.
- Identifying indicia such as the application number (see 37 CFR 1.84(c)) should be written on the drawings in the front (not the back) of each sheet. Replacement sheet(s) should be labeled as such in the header according to 37 CFR 1.121(d).
- 6.  DEPOSIT OF and/or INFORMATION about the deposit of BIOLOGICAL MATERIAL must be submitted. Note the attached Examiner's comment regarding REQUIREMENT FOR THE DEPOSIT OF BIOLOGICAL MATERIAL.

**Attachment(s)**

- |  |  |
|--|--|
| 1. <input type="checkbox"/> Notice of References Cited (PTO-892)   | 5. <input type="checkbox"/> Notice of Informal Patent Application                      |
| 2. <input type="checkbox"/> Notice of Draftsperson's Patent Drawing Review (PTO-948)                       | 6. <input type="checkbox"/> Interview Summary (PTO-413),<br>Paper No./Mail Date _____. |
| 3. <input type="checkbox"/> Information Disclosure Statements (PTO/SB/08),<br>Paper No./Mail Date _____    | 7. <input type="checkbox"/> Examiner's Amendment/Comment                               |
| 4. <input type="checkbox"/> Examiner's Comment Regarding Requirement for Deposit<br>of Biological Material | 8. <input checked="" type="checkbox"/> Examiner's Statement of Reasons for Allowance   |
|  | 9. <input type="checkbox"/> Other _____.   |

## **DETAILED ACTION**

### ***Response to Amendment***

In response to the amendment filed October 15, 2007 wherein applicant cancels claims 1-36, 52-62 and claims 37-51 are pending in this application.

### ***Reasons for Allowance***

Claims 37-51 are allowed for the reasons set forth in the decision of The Board of Patent Appeals and Interferences filed August 7, 2007.

### ***Conclusion***

Any inquiry concerning this communication or earlier communications from the examiner should be directed to Alex P. Rada whose telephone number is 571-272-4452. The examiner can normally be reached on Monday - Friday, 08:00-16:00.

If attempts to reach the examiner by telephone are unsuccessful, the examiner's supervisor, Robert Pezzuto can be reached on 571-272-6996. The fax phone number for the organization where this application or proceeding is assigned is 571-273-8300.

Art Unit: 3714

Information regarding the status of an application may be obtained from the Patent Application Information Retrieval (PAIR) system. Status information for published applications may be obtained from either Private PAIR or Public PAIR. Status information for unpublished applications is available through Private PAIR only. For more information about the PAIR system, see <http://pair-direct.uspto.gov>. Should you have questions on access to the Private PAIR system, contact the Electronic Business Center (EBC) at 866-217-9197 (toll-free). If you would like assistance from a USPTO Customer Service Representative or access to the automated information system, call 800-786-9199 (IN USA OR CANADA) or 571-272-1000.

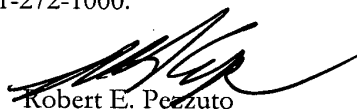
  
Robert E. Pezzuto  
Supervisory Patent Examiner  
Art Unit 3714

  
APR





UNITED STATES PATENT AND TRADEMARK OFFICE

UNITED STATES DEPARTMENT OF COMMERCE  
 United States Patent and Trademark Office  
 Address: COMMISSIONER FOR PATENTS  
 P.O. Box 1450  
 Alexandria, Virginia 22313-1450  
 www.uspto.gov

BIB DATA SHEET

CONFIRMATION NO. 3225

<b>SERIAL NUMBER</b> 09/688,501	<b>FILING or 371(c) DATE</b> 10/16/2000	<b>CLASS</b> 463	<b>GROUP ART UNIT</b> 3714	<b>ATTORNEY DOCKET NO.</b> 47079-00077		
<b>APPLICANTS</b> Shridhar P. Joshi, Skokie, IL;						
** CONTINUING DATA ***** <i>NONE AM</i>						
** FOREIGN APPLICATIONS ***** <i>NONE ATZ</i>						
** IF REQUIRED, FOREIGN FILING LICENSE GRANTED ** 12/21/2000						
Foreign Priority claimed <input type="checkbox"/> Yes <input checked="" type="checkbox"/> No	35 USC 119(a-d) conditions met <input type="checkbox"/> Yes <input type="checkbox"/> No	<input type="checkbox"/> Met after Allowance Initials	<b>STATE OR COUNTRY</b> IL	<b>SHEETS DRAWINGS</b> 3	<b>TOTAL CLAIMS</b> <i>28 JS</i>	<b>INDEPENDENT CLAIMS</b> <i>23</i>
<b>ADDRESS</b> NIXON PEABODY LLP 161 N CLARK ST. 48TH FLOOR CHICAGO, IL 60601-3213 UNITED STATES						
<b>TITLE</b> Method of transferring gaming data on a global computer network						
<b>FILING FEE RECEIVED</b> 1398	FEES: Authority has been given in Paper No. _____ to charge/credit DEPOSIT ACCOUNT No. _____ for following:			<input type="checkbox"/> All Fees <input type="checkbox"/> 1.16 Fees (Filing) <input type="checkbox"/> 1.17 Fees (Processing Ext. of time) <input type="checkbox"/> 1.18 Fees (Issue) <input type="checkbox"/> Other _____ <input type="checkbox"/> Credit		

<b>Issue Classification</b> 	<b>Application/Control No.</b> 09/688,501	<b>Applicant(s)/Patent under Reexamination</b> JOSHI, SHRIDHAR P.
	<b>Examiner</b> Alex P. Rada	<b>Art Unit</b> 3714

ISSUE CLASSIFICATION										
ORIGINAL				INTERNATIONAL CLASSIFICATION						
CLASS		SUBCLASS		CLAIMED			NON-CLAIMED			
463		42		A	63	F	9	/24		/
CROSS REFERENCES										/
CLASS	SUBCLASS (ONE SUBCLASS PER BLOCK)									/
463	16									/
										/
										/
										/
										/

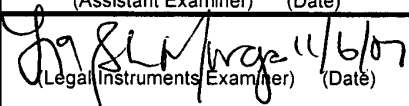
Alex F. R. P. Rada II 10/25/2007 (Assistant Examiner) (Date)	 <b>ROBERT E. PEZZUTO</b> PRIMARY EXAMINER (Primary Examiner) (Date)	<b>Total Claims Allowed: 15</b>				
 (Legal Instruments Examiner) (Date)		<table border="1" style="width: 100%;"> <tr> <th>O.G. Print Claim(s)</th> <th>O.G. Print Fig.</th> </tr> <tr> <td style="text-align: center;">1</td> <td style="text-align: center;">1</td> </tr> </table>	O.G. Print Claim(s)	O.G. Print Fig.	1	1
O.G. Print Claim(s)	O.G. Print Fig.					
1	1					

<input type="checkbox"/> Claims renumbered in the same order as presented by applicant		<input type="checkbox"/> CPA		<input type="checkbox"/> T.D.		<input type="checkbox"/> R.1.47	
Final	Original	Final	Original	Final	Original	Final	Original
	1		31		61		91
	2		32		62		92
	3		33		63		93
	4		34		64		94
	5		35		65		95
	6		36		66		96
	7	1	37		67		97
	8	2	38		68		98
	9	3	39		69		99
	10	4	40		70		100
	11	5	41		71		101
	12	6	42		72		102
	13	7	43		73		103
	14	8	44		74		104
	15	9	45		75		105
	16	10	46		76		106
	17	11	47		77		107
	18	12	48		78		108
	19	13	49		79		109
	20	14	50		80		110
	21	15	51		81		111
	22		52		82		112
	23		53		83		113
	24		54		84		114
	25		55		85		115
	26		56		86		116
	27		57		87		117
	28		58		88		118
	29		59		89		119
	30		60		90		120
							121
							122
							123
							124
							125
							126
							127
							128
							129
							130
							131
							132
							133
							134
							135
							136
							137
							138
							139
							140
							141
							142
							143
							144
							145
							146
							147
							148
							149
							150
							151
							152
							153
							154
							155
							156
							157
							158
							159
							160
							161
							162
							163
							164
							165
							166
							167
							168
							169
							170
							171
							172
							173
							174
							175
							176
							177
							178
							179
							180
							181
							182
							183
							184
							185
							186
							187
							188
							189
							190
							191
							192
							193
							194
							195
							196
							197
							198
							199
							200
							201
							202
							203
							204
							205
							206
							207
							208
							209
							210

**Index of Claims**



Application/Control No.

09/688,501

Examiner

Alex P. Rada

Applicant(s)/Patent under Reexamination

JOSHI, SHRIDHAR P.

Art Unit

3714

√	Rejected
=	Allowed

-	(Through numeral) Cancelled
+	Restricted

N	Non-Elected
I	Interference

A	Appeal
O	Objected

Claim		Date			
Final	Original	10/25/07			
	1				
	2				
	3				
	4				
	5				
	6				
	7				
	8				
	9				
	10				
	11				
	12				
	13				
	14				
	15				
	16				
	17				
	18				
	19				
	20				
	21				
	22				
	23				
	24				
	25				
	26				
	27				
	28				
	29				
	30				
	31				
	32				
	33				
	34				
	35				
	36				
1	37	=			
2	38	=			
3	39	=			
4	40	=			
5	41	=			
6	42	=			
7	43	=			
8	44	=			
9	45	=			
10	46	=			
11	47	=			
12	48	=			
13	49	=			
14	50	=			

Claim		Date			
Final	Original	10/25/07			
15	51	=			
	52				
	53				
	54				
	55				
	56				
	57				
	58				
	59				
	60				
	61				
	62				
	63				
	64				
	65				
	66				
	67				
	68				
	69				
	70				
	71				
	72				
	73				
	74				
	75				
	76				
	77				
	78				
	79				
	80				
	81				
	82				
	83				
	84				
	85				
	86				
	87				
	88				
	89				
	90				
	91				
	92				
	93				
	94				
	95				
	96				
	97				
	98				
	99				
	100				

Claim		Date			
Final	Original				
	101				
	102				
	103				
	104				
	105				
	106				
	107				
	108				
	109				
	110				
	111				
	112				
	113				
	114				
	115				
	116				
	117				
	118				
	119				
	120				
	121				
	122				
	123				
	124				
	125				
	126				
	127				
	128				
	129				
	130				
	131				
	132				
	133				
	134				
	135				
	136				
	137				
	138				
	139				
	140				
	141				
	142				
	143				
	144				
	145				
	146				
	147				
	148				
	149				
	150				

**Search Notes**



Application/Control No.

09/688,501

Examiner

Alex P. Rada

Applicant(s)/Patent under Reexamination

JOSHI, SHRIDHAR P.

Art Unit

3714

**SEARCHED**

Class	Subclass	Date	Examiner

**INTERFERENCE SEARCHED**

Class	Subclass	Date	Examiner
463	42	10/25/2007	APR
463	16	10/25/2007	APR

**SEARCH NOTES  
(INCLUDING SEARCH STRATEGY)**

	DATE	EXMR
Updated East search	10/25/2007	APR
Interference and Class/subclass search	10/25/2007	APR



RCE 3714  
JFW

<p align="center"><b>Request For Continued Examination (RCE) Transmittal</b></p> <p>Address to: Commissioner for Patents P.O. Box 1450 Alexandria, VA 22313-1450</p>	Application Number	09/688,501
	Filing Date	October 16, 2000
	First Named Inventor	Shridhar P. Joshi
	Art Unit	3714
	Examiner Name	Alex P. Rada
	Attorney Docket Number	247079-000077USPT

This is a Request for Continued Examination (RCE) under 37 CFR 1.114 of the above-identified application. Request for Continued Examination (RCE) practice under 37 CFR 1.114 does not apply to any utility or plant application filed prior to June 8, 1995, or to any design application.

1. **Submission required under 37 CFR 1.114** Note: If the RCE is proper, any previously filed unentered amendments and amendments enclosed with the RCE will be entered in the order in which they were filed unless applicant instructs otherwise. If applicant does not wish to have any previously filed unentered amendment(s) entered, applicant must request non-entry of such amendment(s).

a.  Previously submitted. If a final Office action is outstanding, any amendments filed after the final Office action may be considered as a submission even if this box is not checked.

i.  Consider the arguments in the Appeal Brief or Reply Brief previously filed on \_\_\_\_\_

ii.  Other \_\_\_\_\_

b.  Enclosed

i.  Amendment/Reply

ii.  Affidavit(s)/Declaration(s)

iii.  Information Disclosure Statement (IDS)

iv.  Other \_\_\_\_\_

2. **Miscellaneous**

a.  Suspension of action on the above-identified application is requested under 37 CFR 1.103(c) for a period of \_\_\_\_\_ months. (Period of suspension shall not exceed 3 months; Fee under 37 CFR 1.17(i) required)

b.  Other \_\_\_\_\_

3. **Fees** The RCE fee under 37 CFR 1.17(e) is required by 37 CFR 1.114 when the RCE is filed.

a.  The Director is hereby authorized to charge the following fees, or credit any overpayments, to Deposit Account No. 50-4181. I have enclosed a duplicate copy of this sheet.

i.  RCE fee required under 37 CFR 1.17(e)

ii.  Extension of time fee (37 CFR 1.136 and 1.17) (for one month)

iii.  Other Check for RCE Fee

b.  Check in the amount of \$ 810.00 enclosed

c.  Payment by credit card (Form PTO-2038 enclosed)

SIGNATURE OF APPLICANT, ATTORNEY, OR AGENT REQUIRED			
Signature		Date	December 3, 2007
Name (Print/Type)	Justin D. Swindells	Registration No.	48,733



IN THE UNITED STATES PATENT AND TRADEMARK OFFICE

Application No.: 09/688,501  
Applicant: Shridhar P. Joshi  
Filed: October 16, 2000  
Title: Method Of Transferring Gaming Data On A Global Computer Network  
TC/A.U.: 3714  
Examiner: Alex P. Rada

Docket No.: 247079-000077USPT  
Customer No.: 70243

MS Amendment  
Commissioner for Patents  
P.O. Box 1450  
Alexandria, VA 22313-1450

CERTIFICATE OF MAILING

I hereby certify that this correspondence is being deposited with the United States Postal Service as first class mail, postage prepaid, in an envelope addressed to the Commissioner for Patents, P.O. Box 1450, Alexandria, VA 22313-1450, on December 3, 2007.

Signature: 

Joanna Pinos

**THIRD INFORMATION DISCLOSURE  
STATEMENT UNDER 37 C.F.R. §§ 1.97 AND 1.98**

Dear Sir:

In compliance with the duty of disclosure under 37 C.F.R. § 1.56, it is respectfully requested that this Third Information Disclosure Statement be entered, and the references listed on enclosed Form PTO-1449 be considered by the Examiner and made of record. In accordance with the waiver of 37 C.F.R. § 1.98(d), copies of the listed references are enclosed.

This Third Information Disclosure Statement is being submitted concurrent with a Request for Continued Examination. Payment of the \$810.00 fee identified in 37 C.F.R. § 1.17(e) to request continued examination pursuant to 37 C.F.R. § 1.114 is authorized in the enclosed Request For Continued Examination. No other fees are believed due at this time; however, the Commissioner is authorized to charge any additional fees that may be due or credit any overpayments (except the issue fee), while this application is pending, to Nixon Peabody LLP Deposit Account No. 50-4181 (Ref. No. 247079-000077USPT).

Respectfully submitted,



Date: December 3, 2007

---

Justin D. Swindells  
Registration No. 48,733  
NIXON PEABODY LLP  
161 North Clark Street  
48<sup>th</sup> Floor  
Chicago, Illinois 60601  
312-425-3900

ATTORNEY FOR APPLICANT

Form PTO-1449 (modified)	Atty. Docket No. 247079-000077USPT	Serial No. 09/688,501
List of Patents and Publications for Applicant's <b>3RD INFORMATION DISCLOSURE STATEMENT</b>	Applicant Shridhar P. Joshi	
	Filing Date: 10/16/00	Group: 3714

Page 1 of 2

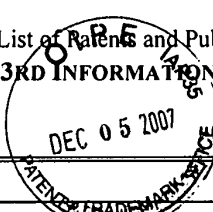

### U.S. Patent Documents

Exam. Init.	Ref. Des.	Document Number	Date	Name	Class	Sub Class	Filing Date if App.
	C01	4,858,930	8/22/89	Sato	273	85	
	C02	5,489,103	2/6/96	Okamoto	273	433	
	C03	5,655,961	8/12/97	Acres et al.	463	27	
	C04	5,707,286	1/13/98	Carlson	463	16	
	C05	5,759,102	6/2/98	Pease et al.	463	42	
	C06	5,800,268	9/1/98	Molnick	463	40	
	C07	5,816,918	10/6/98	Kelly et al.	463	16	
	C08	5,971,271	10/26/99	Wynn et al.	235	380	
	C09	5,999,808	12/7/99	LaDue	455	412	
	C10	6,077,162	6/20/00	Weiss	463	26	
	C11	6,080,062	6/27/00	Olson	463	42	
	C12	6,089,975	7/18/00	Dunn	463	16	
	C13	6,113,495	9/5/00	Walker et al.	463	42	
	C14	6,135,884	10/24/00	Hedrick et al.	463	20	
	C15	6,135,887	10/24/00	Pease et al.	463	42	
	C16	6,210,274	4/3/01	Carlson	463	16	
	C17	6,272,223	8/7/01	Carlson	380	251	
	C18	6,273,821	8/14/01	Moriguchi	463	42	
	C19	6,287,200	9/11/01	Sharma	463	40	
	C20	6,334,104	12/25/01	Hirai	704	258	
	C21	6,346,048	2/12/02	Ogawa et al.	463	42	
	C22	6,354,946	3/12/02	Finn	463	40	
	C23	6,402,618	6/11/02	Reed et al.	463	40	
	C24	6,409,602	6/25/02	Wiltshire et al.	463	42	
	C25	6,428,413	8/6/02	Carlson	463	16	
	C26	6,454,650	9/24/02	Aronin	463	17	
	C27	6,652,378	11/25/03	Cannon et al.	463	20	

<b>EXAMINER:</b>	<b>DATE CONSIDERED:</b>
EXAMINER: INITIAL IF REFERENCE CONSIDERED, WHETHER OR NOT CITATION IS IN CONFORMANCE WITH MPEP609; DRAW LINE THROUGH CITATION IF NOT IN CONFORMANCE AND NOT CONSIDERED. INCLUDE COPY OF THIS FORM WITH NEXT COMMUNICATION TO APPLICANT.	

*INFORMATION DISCLOSURE STATEMENT — PTO-1449 (MODIFIED)*



Form PTO-1449 (modified)	Atty. Docket No. 247079-000077USPT	Serial No. 09/688,501
List of Patents and Publications for Applicant's <b>3RD INFORMATION DISCLOSURE STATEMENT</b>	Applicant Shridhar P. Joshi	
	Filing Date: 10/16/00	Group: 3714
Page 2 of 2		

U.S. Patent Documents							
Exam. Init.	Ref. Des.	Document Number	Date	Name	Class	Sub Class	Filing Date if App.
	C28	6,749,510	6/15/04	Giobbi	463	42	
	C29	6,805,634	10/19/04	Wells et al.	463	42	
	C30	6,986,055	1/10/06	Carlson	713	200	
	C31	7,260,834	8/21/07	Carlson	726	4	
	C32	2001/0044337 A1	11/22/01	Rowe et al.	463	29	
	C33	2001/0044339 A1	11/22/01	Cordero et al.	463	42	
	C34	2002/0045484 A1	4/18/02	Eck et al.	463	42	
	C35	2002/0037767 A1	3/28/02	Ebin	463	25	
	C36	2002/0137217 A1	9/26/02	Rowe	436	42	
	C37	2002/0138594 A1	9/26/02	Rowe	709	219	
	C38	2002/0073043 A1	6/13/02	Herman et al.	705	64	
	C39	2002/0087876 A1	7/4/02	Larose	713	200	
	C40	2002/0116615 A1	8/22/02	Nguyen et al.	713	168	
	C41	2003/0162589 A1	8/28/03	Nguyen et al.	463	25	
	C42	2003/0028567	2/6/03	Carlson	708	250	
	C43	2004/0209660 A1	10/21/04	Carlson et al.	463	01	
	C44	2005/0193209	9/1/05	Saunders et al.	713	182	
	C45	2006/0165235	7/27/06	Carlson	380	268	

FOREIGN PATENT DOCUMENTS							
Examiner Initial	Ref.	Document Number	Date	Country	Class	Sub-Class	Translation Yes/No
	D1	WO 98/35309 A1	8/13/98	PCT	G06F		
	D2	WO 01/91866 A1	12/6/01	PCT	A63F		
	D3	WO 04/034223 A2	4/22/04	PCT	G06F		

<b>EXAMINER:</b>	<b>DATE CONSIDERED:</b>
EXAMINER: INITIAL IF REFERENCE CONSIDERED, WHETHER OR NOT CITATION IS IN CONFORMANCE WITH MPEP609; DRAW LINE THROUGH CITATION IF NOT IN CONFORMANCE AND NOT CONSIDERED. INCLUDE COPY OF THIS FORM WITH NEXT COMMUNICATION TO APPLICANT.	

INFORMATION DISCLOSURE STATEMENT — PTO-1449 (MODIFIED)

10821305.1



INTERNATIONAL APPLICATION PUBLISHED UNDER THE PATENT COOPERATION TREATY (PCT)

<p>(51) International Patent Classification <sup>6</sup> : <b>G06F 17/60</b></p>	<p><b>A1</b></p>	<p>(11) International Publication Number: <b>WO 98/35309</b> (43) International Publication Date: 13 August 1998 (13.08.98)</p>
<p>(21) International Application Number: PCT/AU98/00072 (22) International Filing Date: 10 February 1998 (10.02.98) (30) Priority Data: PO 5041 10 February 1997 (10.02.97) AU PO 8622 15 August 1997 (15.08.97) AU (71) Applicant (for all designated States except US): ARISTOCRAT LEISURE INDUSTRIES PTY. LTD. [AU/AU]; 85-113 Dunning Avenue, Rosebery, NSW 2018 (AU). (72) Inventor; and (75) Inventor/Applicant (for US only): MUIR, Robert, Linley [AU/AU]; 2/9 Premier Street, Neutral Bay, NSW 2089 (AU). (74) Agent: F.B. RICE &amp; CO.; 605 Darling Street, Balmain, NSW 2041 (AU).</p>		<p>(81) Designated States: AL, AM, AT, AU, AZ, BA, BB, BG, BR, BY, CA, CH, CN, CU, CZ, DE, DK, EE, ES, FI, GB, GE, GH, GM, GW, HU, ID, IL, IS, JP, KE, KG, KP, KR, KZ, LC, LK, LR, LS, LT, LU, LV, MD, MG, MK, MN, MW, MX, NO, NZ, PL, PT, RO, RU, SD, SE, SG, SI, SK, SL, TJ, TM, TR, TT, UA, UG, US, UZ, VN, YU, ZW, ARIPO patent (GH, GM, KE, LS, MW, SD, SZ, UG, ZW), Eurasian patent (AM, AZ, BY, KG, KZ, MD, RU, TJ, TM), European patent (AT, BE, CH, DE, DK, ES, FI, FR, GB, GR, IE, IT, LU, MC, NL, PT, SE), OAPI patent (BF, BJ, CF, CG, CI, CM, GA, GN, ML, MR, NE, SN, TD, TG).</p> <p><b>Published</b> With international search report.</p>

(54) Title: DISTRIBUTED GAME ACCELERATOR

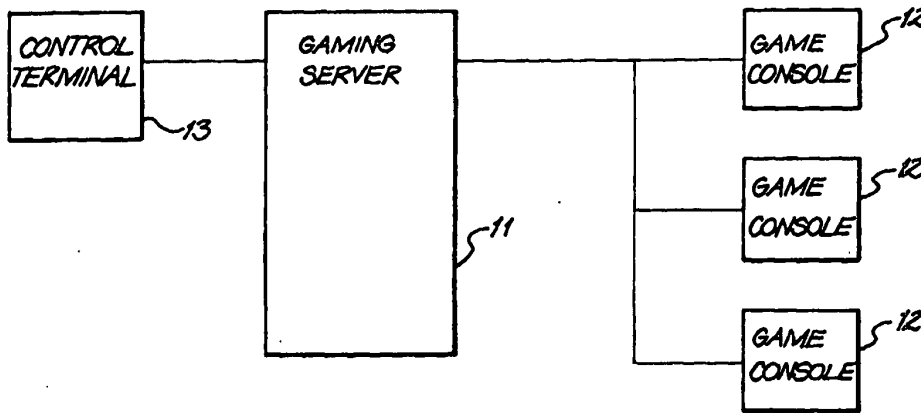

(57) Abstract

A method and apparatus are provided, in which a gaming server (11) is responsible for accounting, game play, and payouts, while the game console (12) is primarily responsible for presenting the user interface. In the general case, communication delays are eliminated by generating game outcomes locally to the console which will be used to determine game outcome to the console prior to the player making their selection. The random numbers used to generate game outcomes are generated in a highly secure device and cannot be used to determine the correct choice of player selection or influence the game outcome. When the player makes a selection the random numbers are already available to the console and the game outcome can be determined and displayed immediately, independent of communication delays.

**FOR THE PURPOSES OF INFORMATION ONLY**

Codes used to identify States party to the PCT on the front pages of pamphlets publishing international applications under the PCT.

AL	Albania	ES	Spain	LS	Lesotho	SI	Slovenia
AM	Armenia	FI	Finland	LT	Lithuania	SK	Slovakia
AT	Austria	FR	France	LU	Luxembourg	SN	Senegal
AU	Australia	GA	Gabon	LV	Latvia	SZ	Swaziland
AZ	Azerbaijan	GB	United Kingdom	MC	Monaco	TD	Chad
BA	Bosnia and Herzegovina	GE	Georgia	MD	Republic of Moldova	TG	Togo
BB	Barbados	GH	Ghana	MG	Madagascar	TJ	Tajikistan
BE	Belgium	GN	Guinea	MK	The former Yugoslav Republic of Macedonia	TM	Turkmenistan
BF	Burkina Faso	GR	Greece	ML	Mali	TR	Turkey
BG	Bulgaria	HU	Hungary	MN	Mongolia	TT	Trinidad and Tobago
BJ	Benin	IE	Ireland	MR	Mauritania	UA	Ukraine
BR	Brazil	IL	Israel	MW	Malawi	UG	Uganda
BY	Belarus	IS	Iceland	MX	Mexico	US	United States of America
CA	Canada	IT	Italy	NE	Niger	UZ	Uzbekistan
CF	Central African Republic	JP	Japan	NL	Netherlands	VN	Viet Nam
CG	Congo	KE	Kenya	NO	Norway	YU	Yugoslavia
CH	Switzerland	KG	Kyrgyzstan	NZ	New Zealand	ZW	Zimbabwe
CI	Côte d'Ivoire	KP	Democratic People's Republic of Korea	PL	Poland		
CM	Cameroon	KR	Republic of Korea	PT	Portugal		
CN	China	KZ	Kazakistan	RO	Romania		
CU	Cuba	LC	Saint Lucia	RU	Russian Federation		
CZ	Czech Republic	LI	Liechtenstein	SD	Sudan		
DE	Germany	LK	Sri Lanka	SE	Sweden		
DK	Denmark	LR	Liberia	SG	Singapore		
EE	Estonia						

## *Distributed game accelerator*

### Introduction

The present invention relates to the field of gaming machines and in particular the invention provides a method and apparatus for speeding up the response time of games played over a network, beyond that achievable using traditional systems.

### Background of the Invention

Traditionally gaming machines have been provided as stand alone devices connected via a network for information gathering, however in the recent past, distributed gaming systems have been proposed to meet the changing needs of the gaming industry.

In a distributed gaming system games are split across the server and console. In its simplest form, when the player presses the 'play' button on the console, the console relays that fact to the server. The server may then decide to start a game, and if so instructs the console to initiate a spinning reel display. The spinning reel display will run for a set period and then come to a stop with a certain set of symbols showing, as directed by the server. The players account is adjusted by the server according to the game outcome. The console is instructed of the account details by the server for display.

It is a fundamental requirement for security that the game outcome and accounting are solely determined by the server. The console simply provides a user interface. If the game were to be in any way independently controlled by the console then the potential would exist for tampering. Therefore considerable data must be exchanged between the server and console, however communication delays limit the speed and interactivity of games.

The combinations of a game describe the mathematical structure of the game and define all possible games, including the winning patterns and the payouts associated with each. From the combinations the game statistics are determined, including the theoretical return to the player.

A limitation and crucial factor in game play in a traditional distributed gaming system is the response time of games to user input. This time is determined by network and server response times. If either of these is not adequate then the user will notice delays in playing the game.

A game used as an example is the red/black double up. It is a common feature game requiring a fast response time. A card is shown face down on the display so that the colour cannot be seen. The game selects a colour for the card, and the player tries to guess what colour the card is, ie. red or black. The player has a 50% chance of guessing the correct colour and wins double or nothing.

Consider the red/black double up game. When the player makes a selection they expect to instantly be shown the outcome. Any delay must be kept small for the game to be playable. In existing systems it was a requirement that the network did not impose significant delays, or alternatively that games played on the system were designed to make such delays less noticeable.

In this context, the term "outcome" can have two meanings:-

- a) the indicia or images displayed at the end of a game
- b) the result of the gamble (ie, win/loss and value of prize).

The first of these outcomes we will call the 'game outcome' while the second we will call the 'gamble outcome'. In most game types, game outcome and the gamble outcome are directly linked. However, in some instances, such as the red/black gamble referred to above, they are not because the game outcome is a particular colour of card while the gamble outcome will depend upon which colour was selected by the player. The gamble outcome is also determined by the size of bet selected by the player. The term "outcome" describes the combination of both the game outcome and the gamble outcome.

### **Summary of the Invention**

According to a first aspect, the present invention provides a method of operating a gaming system including at least one gaming console, the console including secure storage means and a user interface allowing a user to initiate a game and observe a result, the method including the steps of:

storing game or gamble outcome information in the secure storage means for use by the console to produce a game or gamble outcome;  
and

upon receipt of a user input initiating a game, producing a game play sequence including a game and/or gamble outcome indication determined by the game or gamble outcome information stored in the secure storage means alone or in combination with a user input.

According to a second aspect, the present invention provides a gaming system including at least one gaming console, the console including secure storage means and a user interface allowing a user to initiate a game and observe a result, the system including:

5 secure storage means for storing game or gamble outcome information used by the console to produce a game or gamble outcome; and

game control means in the console arranged to receive a user input initiating a game and to produce a game play sequence including a game and/or gamble outcome indication determined by the game or gamble outcome information stored in the secure storage means alone or in combination with a user input.

According to a third aspect, the present invention provides a secure storage means for use in a gaming console which includes a user interface allowing a user to initiate a game and observe a result, the secure storage means being arranged to store game or gamble outcome information used to produce a game or gamble outcome.

According to a fourth aspect, the present invention provides a secure removable control device for use in a gaming console which includes a user interface allowing a user to initiate a game and observe a result, the control device being arranged to generate game or gamble outcome information used by the console to produce a game or gamble outcome.

The information stored in the secure storage means or generated by the control device may be a sequential list of outcome information relating to a sequence of future games to be played on the console, a set of random numbers sufficient to generate one or more entire game outcomes, or a random number seed from which outcome information relating to a sequence of future games to be played on the console is generated by operation of a pseudo-random number algorithm. Preferably, the game outcome information generated by a pseudo-random number algorithm, will be in the form of a set of random numbers sufficient to generate an entire game outcome.

In one possible embodiment the outcome information is a random number indicating a gamble outcome value and the secure processing means in the console then chooses a game outcome which will achieve that gamble

outcome value, however generally the information will indicate an outcome and the gamble outcome value will be determined from the game outcome.

Preferably the secure storage means or control device is removably connectable to or readable and writable by the console.

5 In one embodiment, the information relating to future game outcomes stored in the secure storage means is stored before the secure storage means is connected to the console. Preferably the secure storage means is a programmable card which is preprogrammed with outcome information before or after acquisition by a user and is inserted into the console by the  
10 user to produce one or more game outcomes on the respective console.

In one embodiment the production of the game outcome indication is performed in a secure processing means connected to the secure storage means by way of a secure communications path.

15 Preferably also the secure processing means or control device includes a smartcard or smartcard chip which is either removably inserted into or permanently fixed in the console.

The console and therefore the secure storage means or control device, may or may not be connected to the server when the game is played, but in either event, when the secure storage means or control device is next  
20 connected to the server, it will generate and send a signal to the server indicating that the stored precalculated result has been used.

According to a further aspect, the present invention provides a virtual casino including a plurality of virtual gaming machines (or gaming consoles, each gaming machine or console having dedicated accounting, and  
25 combinations, being uniquely identified and capable of being returned to at any time by the player provided it is not in use by another player.

In a virtual casino, as in a traditional casino, if another player is using a particular virtual machine then, the player must wait or play another machine. Preferably embodiments of the invention will allow a player to  
30 view a virtual machine while it is being played by another player.

The return remains with the machine for the life of that machine. Unused return is mathematically equivalent to money and can thus be transferred between games, either as money or combinations changes. To be  
35 fair to players and prevent the casino from cheating, when player accounts are shut down, virtual game machines are ended, the gaming site is to be closed, or jackpots are cancelled, etc, the extra accumulated return owed to

players is transferred from the various accounts and redistributed among the players, as jackpots, credits, combinations, etc.

Preferably, the game outcome determining data is stored in the secure storage means and the game outcome is calculated from the data in a secure processing means connected to the secure storage means by way of a secure communications path.

The data precalculated by the server and sent to the secure storage means in the console, may be in the form of a set of random numbers sufficient to generate an entire game outcome (ie, 5 random numbers in the case of a slot machine with a 5 reel display) or alternatively, the precalculated data may be a random seed from which the secure processing means may calculate the required number of random numbers using a pseudo-random number generating program. In another alternative arrangement, the server may calculate an actual game outcome (eg, reel stopping positions or indicia) and transmit codes indicating these positions although this arrangement is inconvenient in a machine capable of playing any one of a number of player selectable games as the server would have to precalculate outcomes for each possible game.

In an alternate embodiment, predetermined outcomes can be implemented using a smartcard as the secure storage and processing means, with predetermined bets and outcomes stored simply as a list of values. Initially all values on the card (except the first which is the initial value of the card) are hidden and playing games discloses the values one by one. The player may redeem the card at any time for the amount of the last disclosed value. The console displays an appropriate game which generates the new value. The player buys a smartcard (or downloads values from a casino) with a fixed number of values. An advantage of this system is that the casino knows the wins and losses of every card released and can adjust the pattern of wins and losses as desired.

In another embodiment a smartcard is provided with a list of predetermined outcomes, with the player making bets on each outcome. The outcomes are initially hidden and are disclosed one at a time as games are played. For each outcome disclosed the player first makes a bet, which is written to the smartcard (in non-volatile memory). The total value owed to the player is simply the sum of wins and losses for each bet and outcome. The player redeems the card for value stored by returning the card. This may



be implemented with a very simple and hence cheap smartcard, requiring only secure memory storage with controlled access. In another implementation the value is redeemed via secure communications with a game server.

5       The smartcard may be programmed with multiple functions, only one of which is a gaming accelerator. In other modes the smartcard may for example be used as an ID card, a credit card, a bankcard (eg. ATM), etc. The protocol to access the smartcard may be an extension to another, perhaps primary, mode of the smartcard.

10       In yet another possible alternative arrangement, the server calculates a number indicating a gamble outcome value (per unit bet) and the secure processing means in the console then chooses an outcome which will achieve that win value. This arrangement will work better with some games than others, although, the concept could be altered to suit each game played.

15       In preferred embodiments of the invention, signals generated by the server and console to send game outcomes or to indicate game play, are encrypted prior to being sent.

20       Preferably, also encrypted signals are each provided with a piece of unique information prior to encryption such that different signals containing the same game information are not the same after encryption.

25       Preferably also, the server includes an auditing function to check the game and/or gamble outcome data returned from the secure device in the console.

30       In one embodiment of the invention, the secure storage and processing means is a smart card which may be permanently fixed in the console or may be removable and may also be used to carry player identification and credit information. Preferably, when a smart card is used as the secure memory and processing means, the encryption and decryption in the console of signals to and from the server and the game outcome calculation will be performed by the smart card.

35       In one preferred form of the invention, an hierarchical network of gaming servers are provided with the console connected to low order, low security network servers which perform low security and routine control and communication, while passing high security signals to higher level gaming servers having higher security.

**Brief Description of the Drawings**

Embodiments of the invention will now be described, by way of example, with reference to the accompanying drawings in which:-

Figure 1 is a block diagram of a distributed gaming system;

5 Figure 2 is a more detailed block diagram of the server and console components of a distributed gaming system of Figure 1;

Figure 3 is a flow chart showing an initialisation sequence for a system according to the present invention;

10 Figure 4 is a flow chart showing a sequence of steps in the playing of a game on a system according to the present invention;

Figure 5 is a diagram showing a Blackjack hand as it is initially dealt;

Figure 6 is a diagram of a message format for a message from the smartcard and server;

15 Figure 7 is a flow chart showing a random number buffering arrangement;

Figure 8 is a block diagram of a system employing a random number server;

Figure 9 is a block diagram of a distributed gaming system including a security server; and

20 Figure 10 is a block diagram of a distributed gaming system including a network of gaming servers.

**Detailed Description of the Embodiments**

Embodiments of the invention will now be described in which the gaming server 11 (refer to figure 1) is responsible for accounting, game play, 25 and payouts, while the game console 12 is primarily responsible for presenting the user interface. The console 12 may also keep accounts for the player and run the game combinations, but only as an aid to the rapid update of the display. The real accounts and the combinations are held on the server 11 and the player will be paid as the server determines. Although the 30 console 12 can in theory be tampered with to affect the combinations and accounting any changes will be local to the console 12, and cannot affect the accounting on the server 11, and hence payout. For the sake of completeness, a control terminal 13 is illustrated in figure 1. This control terminal is used by the system operator to manage the gaming server 11.

For a system able to transparently cope with significant delays occurring throughout the system several advantages can be derived as follows, depending on the embodiment used.

- A slower response time from the server 11 is allowable. A cheaper, lower performance server system may be used. In a multiple server installation extra servers may even be eliminated. In addition server software will be easier to develop due to the lower performance constraints.
- Network delays may be allowed to increase. Cheaper, lower performance networking may be allowed. Internet gaming performance can be improved.
- Delays associated with distance are ultimately limited by the speed of light, and cannot be overcome. International delays are therefore significant and cannot be reduced beyond a certain point. However embodiments of the invention can reduce or eliminate the effect of such delays.

Network and server delays may be eliminated or significantly reduced at the console 12 in some circumstances by not waiting for a response from the server 11 before giving the player feedback. Some games do not require knowledge of the gamble or game outcome to continue, although the game cannot be completed until it is known.

In the general case, the delay can be effectively eliminated by sending the random numbers which will be used to determine game or gamble outcomes to the console 12 prior to the player making their selection. These numbers are stored in a highly secure device 23 and cannot be used by the player (or a cheat) to determine the correct choice of player selection. When the player makes a selection the random numbers are already available at the console 12 and the game outcome can be determined and displayed immediately.

Games may be played locally on the console 12 in a similar way to that found in a traditional gaming machine. The key difference being that game outcomes are not determined by the console 12, and that they are audited by the server 11. The player's choice is passed to the secure device 23 and it informs the console 12 of the subsequent game outcome. An unforgeable message is generated to advise the game server 11 of the game outcome.

In the embodiment illustrated in the block diagram of figure 2, it will be seen that the server 11 includes a CPU 14 and is used to store

combinations 16 and to perform random number generation 15. The server 11 is connected to one or more consoles 12 via a network 17 and each console 12 includes a CPU 21, a user interface 22 and a secure storage and processing device 23 arranged to provide encryption/decryption functions 24 and game outcome logic 25.

The secure storage and processing means in the console 12 may be achieved by using a relatively standard processor on a separate board within a security cage using techniques presently common in the gaming industry or these functions may be realised in a secure software routine that continuously checks itself for tampering or makes use of a hardware device to constantly monitor itself for validity. The software embodiment, could for example make use of a hardware decryption circuit that decrypts the program and data on the fly during executions and constantly sends encrypted messages to the server 11 to indicate the valid status of the decryption circuit.

In the preferred implementation the secure random number storage and processing device 23 is an ISO 7816 smartcard (or smartcard chip) with embedded microprocessor 21, program ROM and E<sup>2</sup>PROM. The smartcard 23 is provided with an encryption function 24 either via software or a hardware accelerator. The smartcard 23 has a 5 pin interface with serial communications for connection to a reader in the console 12.

The smartcard 23 may be inserted into the console 12 by the player or embedded within it by the manufacturer. A smartcard or smartcard chip may also be enclosed within a module which is inserted into the console 12, for example, within a PCMCIA card which is then plugged into a personal computer.

In the following description the smartcard 23 and server 11 are sometimes referred to as communicating directly with each other, without the aid of the console 12. This is for simplicity of description, but it must be realised that the console 12 must act as the intermediary. The console 12 does not interpret or modify any such communications.

In the following embodiments, the game outcome data is preferably transmitted from the server 11 and stored in the console 12 as a random number seed from which any number of random numbers required for the game may be generated.

The game server 11 is responsible for accounting, game play, and payouts, while the game console 12 is primarily responsible for presenting the user interface. The console 12 may also keep accounts for the player and run the game combinations, but only as an aid to the rapid update of the user interface. The real account and combinations is held on the server 11 and the player will be paid as the server 11 determines. The console in effect presents a simulation of the game that is run on the server. Although the console 12 can in theory be tampered with to affect its combinations and accounting any changes will be local to the console 12, and cannot affect the accounting on the server 11, and hence payout.

#### **Predetermined Outcomes**

In the preferred implementation random numbers within the secure storage and processing device 23 are used to generate game outcomes as required by the console 12. In an alternate method, called predetermined outcomes, the server 11 determines game outcomes prior to games being played and securely transmits them to the secure storage and processing device 23. When a game is played the console 12 requests one of these game outcomes from the secure storage and processing device 23 and produces a display appropriate to the outcome. Game outcome messages are preferably secured using encryption techniques to prevent cheats decoding messages to determine the outcomes before they are played. Alternately physical security of the communications medium may be used.

For example, consider the red/black double-up game. In the preferred implementation the outcome is dependent on the match between the player selection and random number within the smartcard 23. Using predetermined outcomes the secure storage and processing device 23 contains a predetermined win or lose outcome and the player selection makes no difference to the game outcome. The console 12 outputs an appropriate win or lose display according to the predetermined outcome and player selection. If the player wins the console 12 shows the hidden card the same colour as the player's choice, while if the player loses the console shows the opposite colour. The secure storage and processing device 23 generates an unforgeable message to the server 11 informing it of the outcome selected and the amount bet.

Consider also slot games. Again outcome is predetermined, but with the win outcome also containing a win multiplier which is the multiple of

the bet that the player wins. The console 12 displays the outcome appropriate to the win or loss, which may be selected randomly from a range of possible win or loss displays.

The console 12 requests and buffers game outcomes from the server 11 appropriate to the games to be played. Before all of the outcomes have been used the console 12 requests replacement outcomes from the server 11.

In an alternate application, predetermined outcomes can be implemented using a smartcard 23 as the secure storage and processing device 23, with predetermined bets and outcomes stored simply as a list of values. Initially all values on the card (except the first which is the initial value of the card) are hidden and playing games discloses the values one by one. The player may redeem the card at any time for the amount of the last disclosed value. The console 12 displays an appropriate game which generates the new value. The player buys a smartcard (or downloads values from a remote casino) with a fixed number of values. An advantage of this system is that the casino knows the wins and losses of every card released and can adjust the pattern of wins and losses as desired.

In another application a smartcard 23 is provided with a list of predetermined outcomes, with the player making bets on each outcome. The outcomes are initially hidden and are disclosed one at a time as games are played. For each outcome disclosed the player first makes a bet, which is written to the smartcard 23 (in non-volatile memory). The total value owed to the player is simply the sum of wins and losses for each bet and outcome. The player redeems the card for value stored by returning the card. This may be implemented with a very simple and hence cheap smartcard, requiring only secure memory storage with controlled access. In another implementation the value is redeemed via secure communications with a game server 11.

In another implementation the secure storage means and secure processing means are two separate devices, preferably smartcards. Predetermined outcomes and/or bets are loaded from the server to the secure storage means. When the secure processing means and secure storage means are in communication games may be played as the secure processing means uses the predetermined outcomes stored on the secure storage means. The secure storage means may also store the players credit account which is gambled on and adjusted by the secure processing means during game play,

or alternatively a separate secure storage means, preferably yet a further smartcard or smartcard chip is provided to store credit account information. One application of this implementation is where the secure storage means is a multi-application smartcard where the smartcard acts as a secure filing system. Each application is a separate smartcard with secure access to the data file area. The gaming system is simply one of the many applications, with the secure processing means being the other smartcard. A secure access means provides the off-line communication between server and secure storage means to download or update the stored predetermined outcomes and/or credit information.

### Applications

In Internet applications the smartcard 23 may be used in conjunction with a PC via a standard smartcard interface or an adaptor such as a PCMCIA card, or directly connected to a network computing device with built in smartcard interface (eg. Sony WebTV, Oracle NC).

The smartcard 23 (or socket) may be integrated with a modem and game program memory within a module for a game console (eg Sony Playstation or Nintendo Ultra64). The game console 12 is then capable of highly interactive gambling.

The smartcard 23 may have multiple functions, only one of which is a gaming accelerator. In other modes the smartcard 23 may for example be used as an ID card, a credit card, a bankcard (eg. ATM), etc. The protocol to access the smartcard 23 may be an extension to another, perhaps primary, mode of the smartcard.

A secure storage and processing device may be used to enhance security in an otherwise traditional distributed gaming system (such as Internet, hotel in-room gaming or on a ship) by securing the game outcome determining function of the server. Depending on the implementation used and as described elsewhere, random numbers (or game outcomes) are either generated by the secure storage and processing device or received from a random number server at a more secure location. Random numbers (or game outcomes) generated at another location are securely (eg. by encryption) communicated to the game server and hence secure storage and processing device by a communication link or a storage medium such as a CD-ROM or hard disk. The game server sends player requests to the secure

storage and processing device and receives game outcomes, which it then communicates to the player consoles.

#### **Software method of disguising delays**

Network and server delays may be effectively eliminated at the console 12 in some situations by not waiting for a response from the server 11 before giving the player feedback. The game console 12 must be able to process user input and take actions without waiting for commands from the server 11. For example when the user presses play, a message is sent to the server 11 as usual, but the reels also start spinning immediately.

To maintain security it is essential that the outcome of games be determined only by the server 11, but this does not limit the starting of reel spins (or other events), only stopping of the reels. The typical reel spin time of three seconds can easily encompass a network/server delay of two seconds before the game outcome is received and the reels slow down and stop.

If the response was not received within a set period, say 30 seconds, the console 12 would abort the game without the usual stop and clearly indicate to the player that the current game display is invalid, but that a game may have taken place. A message is then sent from the console 12 to the server 11 indicating a time-out error. Two events may have occurred

The server 11 did not receive a start of game message, therefore the game did not take place. A new game may be played.

The server 11 received the start of game message and played the game, but the console 12 did not receive the servers game outcome message. The game has taken place and the players account updated, but the player does not know what happened. The game is redisplayed on the console 12 as soon as possible.

#### **Preferred Implementation**

In the preferred implementation the secure storage and processing device 23 is an ISO 7816 smartcard (or smartcard chip) with embedded microprocessor, program ROM and E<sup>2</sup>PROM. The smartcard 23 is capable of encryption either via software or a hardware accelerator. A smartcard has a 5 pin interface with serial communications.

The implementation could also be a microcontroller or a secure multi-component module. The key requirement being that it is not possible to determine the internal operation of the module, and hence the random numbers or security keys.



**Initialisation**

Communication must be established between the server 11 and smartcard 23 prior to any games taking place. Each smartcard 23 is provided with a unique preprogrammed ID number and secret encryption key.

5 Preferably the ID number and secret encryption key are encoded into the smartcard after manufacture but before distribution to the casino or users. The server is informed of the card ID and matching encryption key, which will be the same as the smartcard's key or different depending on whether symmetric or asymmetric encryption is used.

10 Referring to figure 3, during initialisation the console 12 reads 101, 102 the ID from the smartcard 23 and informs 103, 104 the server 11. The server 11 uses the ID to look up the encryption key used to communicate with the smartcard 23 and allows the console 12 access to the account information once the server 11 has authenticated the smartcard 23. The console 12 may  
15 access the player's account for information including credit available, game preferences and game initialisation, following authentication of the smartcard 23 by encrypted communications.

The ID is not itself required during communication with the smartcard 23, as due to the encryption, if the wrong ID is supplied communications  
20 cannot take place. An exception to this is in an alternate implementation where the same keys are used for all cards, when the ID must be encoded into all messages to prevent the same random numbers being played on more than one card. Although the ID may be the smartcard's public encryption key, preferably, in the interests of security this is not disclosed.

25 Console to server communication of the smartcard ID is one of the few types of message that is not encrypted, as it is performed by the console 12 rather than the smartcard 23. In an alternate implementation these messages may also be encrypted using a public key that the server 11 publishes. Encrypted messages may thus be sent to the server 11 that only the server is  
30 able to decode.

35 Referring again to Figure 3, in the preferred implementation the server 11 first checks 105 the smartcard 23 for unacknowledged games, and the smartcard responds 106 with details of the outstanding games it is holding. The server then transmits 107 an initial game state to the console 12 and enables initiation of game play 109. Where the previous game was interrupted (eg. due to a communications failure or player choice) this

restores the last state of the game. Preferably the initial state includes the current value of the players account. It may also be requested during game play to ensure that the game simulation that the player sees correctly reflects the true account held by the server.

5 In some types of game the combination being played depends on previous games, changing during the course of game play. For example, after 100 games with a return of 85% the player is given 10 games at 90% return. This change in combinations affects the long-term return to the player and therefore the method of initialisation, which can be one of:

- 10
- The server 11 always initialises the game to the same state, maximising the return to the server.
  - The last game state is recorded in the player's account and the same state is restored during initialisation.

15 The last game state of the player is randomly assigned to the next player to play that game. This is analogous to the situation in a casino, when one player finishes with a gaming machine and the next player starts. The average return to the casino does not increase.

#### **Virtual Casino**

20 To further simulate an actual casino environment a Virtual Casino may be created. The Virtual Casino contains a (preferably large) number of virtual gaming machines which act like gaming machines in a traditional casino. Each has it's own accounting, combinations, etc, is uniquely identified and can be returned to at any time by the player, but may only be played by one player at a time. If a player is using a particular virtual machine then as in a traditional casino other players must wait or play another machine. Therefore the return remains with the machine for the life of that machine. To further simulate a real casino players may be able to observe another player play a virtual gaming machine and to start playing that virtual gaming machine when the current player ceases. A queue

25

30 mechanism may be used where multiple players want to play the same virtual gaming machine.

Unused return is mathematically equivalent to money and can thus be transferred between games, either as money or combinations changes. To be fair to players and prevent the casino from cheating, when player accounts are shut down, virtual game machines are ended, the gaming site is to be closed, or jackpots are cancelled, etc, the extra accumulated return owed to

35

players is transferred from the various accounts and redistributed among the players, as jackpots, credits, combinations, etc.

### Game Play

5 In the preferred implementation the smart card generates the random numbers used to calculate game outcomes from an initial seed set prior to use of smart card and optionally periodically updated from the server.

10 In an alternate implementation random number seeds are generated by the server 11 and sent to the smart card prior to each game. In this implementation, the random number seed, combined with an auto-incrementing index (the seed index) is encrypted such that only the smart card can decode it. The smartcard 23 uses the seed to generate as many random numbers as required for the next game. Each time a new seed is generated a unique new index is used. The index is unique to a game and is used to identify that game to the server 11 for the game outcome, and again for the server to acknowledge receipt of the game outcome to the smartcard 23.

15 Figure 4 illustrates the game play sequence, following initialisation in Figure 3 and the selection of a game to play. Once the player has selected the game type the console 12 sends the selection to the smartcard 23, together with the game description and amount bet. The smartcard 23 then writes the game type, player choice(s), amount bet, game outcome and card index to its internal E<sup>2</sup>PROM memory. The smartcard 23 must inform the server 11 of the amount bet, otherwise tampering could occur with the server being told that losses had small bets, while wins had large bets.

20 The console 12 then requests a game outcome, which the smartcard 23 generates, stores in E<sup>2</sup>PROM and then sends to the console, which can immediately display the result to the player. The smartcard 23 also generates an unforgeable encrypted game outcome message for the server containing the game type, gamble, player choice(s), amount bet game outcome, and card index which it sends to the console 12, and hence to the server 11. The server 11 decrypts the message and is thus informed of the game played and is able to adjust the account correctly. The server 11 then sends an acknowledgment to the smartcard 23, which responds by erasing that outcome from its E<sup>2</sup>PROM. Games are recorded in the smartcards E<sup>2</sup>PROM until acknowledged by the server 11. Unacknowledged games will quickly fill the available memory and stop the smartcard from accepting new games.

Security is dependent on it being impossible to determine what encrypted message to send back to the server 11 if the wrong choice of gamble is made. Only the smartcard has this information.

The game type uniquely identifies each type of game to the server 11. Many games may share the same combinations, but each has a different game type. Note that the combination type may be sent instead of the game type, but auditing (to check popularity of games, for example) is better served by sending the game type.

In another variation, after initialisation (eg. power up), the card may refuse all games until any outstanding game outcomes in E<sup>2</sup>PROM have been acknowledged by the server 11.

So far only the first game has been accelerated. To eliminate delays in subsequent games two factors must be considered

- A new game must be able to take place before the server 11 acknowledges receipt of the first game outcome.
- New random numbers must be available immediately.

When the server 11 has not yet acknowledged the previous game before the player starts the next, a number of game outcomes may be stored in E<sup>2</sup>PROM. The next game may be played immediately assuming more random numbers and space is available. Games can continue to be played until the limit of E<sup>2</sup>PROM memory is reached, random numbers are no longer available, the total value of player losses in outstanding games reaches the preset loss limit, etc.

The server 11 may at times require that all game outcomes outstanding in the smartcard must be acknowledged, in particular before the player collects money from their account. The server 11 may query the smartcard for outstanding games, or in an alternate implementation simply maintain a list of the random numbers seeds that have not yet been used.

In the alternative implementation, where the server generates a random number seed for each game, before a game starts a random number seed is generated 108 (refer to Figure 4 and Figure 7) by the server 11, combined with the seed index, encrypted, and sent to the console 12 where it is stored 121 at or prior to start of game play 123. Referring to Figure 7, maintenance of the seed buffer is performed by a background task that regularly tests 140 the state of the seed buffer in the console 12 and if it contains less than a predetermined number of seeds, a request 107 is

generated to the server 11 for more seeds. As the seeds are encrypted and contain an encrypted sequence number, the buffer does not need to be maintained in a secure part of the console 12.

When a game requires a seed to generate a set of random numbers, the console 12 tests the buffer 150 to ensure it is not empty and then retrieves 5 151 a seed and sends 124 the seed to the smart card where it is received 157 and any required additional random numbers generated. In the event that a game requires only one random number, the seed may be used directly as the random number, however, where more numbers are required, the smartcard 10 uses a pseudo-random number algorithm known to the server 11, such that the server can predict the numbers generated by the seed.

Only the smartcard is able to receive and decrypt 124 the seed. Referring to figure 4 the smartcard uses the seed to generate 129 as many random numbers as required for the next game outcome. Each time a new 15 seed is generated 108 a unique new index is used. The index is unique to a game and is used to identify that game to the server 11 when reporting 130 the game outcome, and again for the server to acknowledge receipt 132, 133 of the game outcome to the smartcard.

Once the type of game has been selected 123 by the player the console 20 12 waits 125 for the player to press play 126 and then sends this information to the smartcard with a request 127 for a game outcome, together with the game type and amount bet. The smartcard then writes 128 the received seed index or card index, game type, gamble type, player choice, amount bet and outcome (note: the outcome is not strictly required as the server is also able 25 determine it) to its internal E<sup>2</sup>PROM memory.

The smartcard informs the server 11 of the amount bet otherwise tampering could occur with the server being told that loses had small bets, while wins had large bets.

The game outcome 131 is then sent to the console 12, which can 30 immediately display the result to the player. The smartcard also generates 129 an unforgeable encrypted game outcome message for the server 11 containing the seed index, game type, gamble type, player choice, amount bet and game outcome, which it sends to the console 12, and hence 130 to the server. The server 11 decrypts the message and is thus informed of the game played and is able to adjust 132 the account correctly. The server 11 35 then sends 133 an acknowledgment to the smartcard which responds by

erasing 134 the outcome from its E<sup>2</sup>PROM. When the game is complete 135 the console 12 waits 125 for another player input 126 to commence another game.

Security is dependent on it being impossible to determine what encrypted message to send back to the server 11 if the wrong choice of gamble is made. Only the smartcard knows this and this information is not accessible

When each new random number seed is received the embedded index is checked against that of the most recent game outcome stored in E<sup>2</sup>PROM.

There are three possible outcomes;

- The received index is newer (ie. larger) than that of the last stored game, indicating that it is a new seed, for a new game.
- The received index is the same as the stored index, indicating that the game has already taken place, and the console 12 is so informed. No new gamble choice will be accepted. This may occur if the system aborted the game without completing the transaction (ie. power down) to the console 12, or server 11. It also acts to prevent cheating where the encrypted random numbers are resent and the gamble is tried again with a different choice.
- The received index is older (ie. less) than that of the last stored game. This is either the result of an error in the system or an attempt at cheating. This condition is signalled back to the console 12 and the set of random numbers discarded.

In a variation on the implementation described above, the index must be the next in the sequence for the smartcard to accept the communication. For example, if the last index was 1000, the next must be 1001.

In another variation, after initialisation, (ie, power up) the card may refuse all games until any outstanding game outcomes in E<sup>2</sup>PROM have been acknowledged by the server 11.

Where taxes are required to be paid to government these may be calculated from the player accounts.

#### **High Loss Gambles**

If the value of a gamble is large it may easily exceed the value of the smartcard. If the smartcard is destroyed then any losses outstanding on the smartcard and of which the server 11 is not aware are lost with the smartcard and the player will not have their account on the server debited with the loss.

In some cases it would therefore be in the players best interest to destroy the smartcard and avoid large losses.

A loss limit is programmed into the smartcard, to prevent a single gamble or a series of gambles above the set limit. The loss limit is set by the smartcard issuer to be that value at which it is not worth tampering with the smartcard in this way. In applications where the smartcard is physically secure and there is no question of such tampering, as in a traditional casino environment, a loss limit is not required.

When a series of gambles has been made and are still outstanding (unacknowledged) on the smartcard, the order of notifying the server 11 of game outcomes may be modified to give priority to losses over wins.

One or more of the following methods may be used to deal with high loss games

- The player is charged for a new smartcard. For example a player paying \$50 for a smartcard will not profit by destroying a smartcard with only \$50 losses on it. The loss limit in this case may be \$50.
- The loss limit is set to such a point that even though it is possible to make money by destroying the smartcard it is not economically worthwhile.
- The issuer may detect players who regularly destroy cards and refuse further business with them. Analysis software on the server 11 or off-line aids in detecting suspicious activity.
- The player makes a guarantee to the server 11 for a play limit. If the smartcard is destroyed the player forfeits the amount guaranteed. For example the player guarantees \$500, and the server 11 instructs the smartcard of a new loss limit of \$500. This is analogous to transferring money into the smartcard and if the smartcard is destroyed the player loses \$500.
- The player may only be able to withdraw money from their account on the server 11 by using the smartcard. If the account is in net credit then the player would have to keep the smartcard safe.
- The player must present the smartcard in person to collect winnings, so that the smartcard can be physically examined. This would typically be used if tampering were suspected or the value of the win was large.
- The system may revert to the traditional distributed gaming mode for high value gambles, where games are played directly from the server 11 and the smartcard is not used. The gamble is set up on the server 11, the outcome

solely determined by the server after the player selection and then transmitted to the console 12.

- For high value gambles the console 12 requests a gamble amount from the server 11. The player is then committed to gambling this value or cancelling it via the correct (secure) method. The server 11 responds with an encrypted gamble confirmation message to the smartcard which allows the game to proceed. If tampering takes place and the server 11 never receives a response from the smartcard, the player forfeits the gamble amount initially set up on the server. This method has the delays associated with the traditional method and that this invention is designed to eliminate.
- The smartcard may be a multipurpose card, and destroying it may not be worth the trouble caused, due to the nature of the other functions. It may, for example, also be a bank or credit card.

An attempt may be made to tamper with the system by deleting a losing game outcome message before it reaches the server 11, or system errors may cause the loss of messages. Therefore the previous game is stored in E<sup>2</sup>PROM until the server 11 acknowledges receipt (with an unforgeable message) of the encrypted game outcome message for that game, upon which it may be deleted. The encrypted acknowledge message will at least include an acknowledge code and the card index that identifies that game. One or more of the following methods may be used to detect and prevent tampering where losing messages are deleted.

The server 11 monitors responses from the console 12 and quickly detects lost messages. This is possible using the card index and/or in an alternate implementation the random number seed index. If the cause of lost messages is determined to be the player he is deterred from tampering.

When a message is lost the server 11 cannot acknowledge that game. It will remain in the cards E<sup>2</sup>PROM and contribute to the loss limit and memory space taken up. Eventually the smartcard will become unusable.

Game outcomes are stored in the smartcards E<sup>2</sup>PROM until acknowledged by the server 11. In one implementation, any subsequent communications between the smartcard and server allows the server 11 to uncover these stored outcomes. Therefore to lose messages the smartcard may never again communicate with the server 11. In this implementation all game outcome messages to the server 11 may additionally contain the



number of game outcomes stored in the smartcard. The server 11 may then request these game outcomes from the smartcard.

#### **Game and Function Description To Smart Card**

5 The console 12 informs the smartcard, and hence the server 11, of the game type to be played. Theoretically this is sufficient for the smartcard to know the combinations for that game and the gamble that is about to take place. However a smartcard preprogrammed with this information will not be able to deal with new games, and the large number of possible games may overrun its memory capacity. Therefore in practice it is preferable for the  
10 console 12 to also describe the gamble to the smartcard and hence the server 11.

The game is described to the smartcard using a minimal number of generic descriptions or commands. For some games the generic commands may not be adequate to describe the game and game specific commands may  
15 need to be added. As the smartcard contains a microprocessor virtually any type of game command may be added. In response to a command the smartcard generates a response, stores the appropriate information in the E<sup>2</sup>PROM (for later transmission to the server 11) and then sends a response to the console 12. Generally a game is described by:

- 20 • The console 12 sends a message to the smart card describing some state of the game to the server 11. The card does not interpret the message, but encodes it for transmission to the server 11. By sending the message to the smartcard the console 12 proves to the server 11 that the message (eg. a player selection) was made at a particular point in the game. Messages  
25 include start of game, end of game, player selections, game type, amount bet etc.
- The smartcard generates an array of M random numbers, each in the range 1 to N. The numbers may be independently selected (ie duplicates may exist) or of unique values. The console 12 subsequently requests numbers  
30 from the array, with the smartcard recording the requests and values for transmission to the server 11. Note that a request for a single random number in the range 1 to N is a simple case of an array in which M = 1.

When an array is required exceeding the maximum memory capacity of the smartcard the array is split into multiple sub-arrays that are generated  
35 independently. Using a selection algorithm that is common to both console

12 and server 11 the arrays are merged (in the console 12 and server 11) and if necessary duplicate values are reselected from the smartcard.

Many games have a fixed sequence of events, however the sequence of events in some games depends on the actions of the player. The server 11 must be able to determine the end of a gamble to update the players account. Preferably the console 12 informs the smartcard, and hence the server of the start and end of games, although this may not be necessary for some types of game in which these are implicit. For example, a winning slot game may be followed by a sequence of up to 5 double-ups. The server 11 is able to determine that the game ends if the player loses on the slot game or any of the double-ups, but must be informed if the player chooses not to play the double-ups.

Card games (eg blackjack) usually deal cards from a single deck of 52, which is reshuffled for each game. Traditional casino games usually deal from a deck of 6 packs of cards, to hinder card counting. Games using 6 packs of cards can be handled in two ways. Preferably cards (random numbers) are selected from the smartcard independently and sequentially. If a card is selected that has already been selected 6 or more times then it is reselected until a valid card is selected. Alternately a special game description command can be added that is able to generate an array representing 6 shuffled packs of cards.

Another example of a special game description command is the use of multiple arrays. The preferred implementation is able to generate and select values from only one array. If a game were implemented that required generation and selection of multiple arrays, extra commands would need to be added. Preferably when such commands are added compatibility with old games is maintained.

#### **Double-Up Game Description**

In red/black double-up the player chooses a number (colour) between 1 and 2 which the console 12 sends to the smartcard as a message to the server 11. The console 12 then requests the smartcard to generate a random number between 1 and 2. If the player selection matches the smartcard selection the player wins, otherwise the player loses. Both the console 12 and server 11 can determine the game outcome from the player choice and the smartcards randomly determined choice.

Alternatively the smartcard first generates the random number, the player selects a colour, and only then does the smartcard disclose the colour chosen.

Using the card index the server 11 verifies the player selected the card colour before the colour was disclosed by the smartcard.

#### **Odds Gamble Game Description**

An odds gamble is similar to double up, except the player chooses the odds to play. The odds chosen are both the random number range and the amount by which the stake will be multiplied if the player wins.

Preferably the player chooses the odds, N to 1 (eg. 2:1 or 3:1), and the smartcard generates a random number in the range 1 to N. If the random number is the winning value (eg 1) the player wins, otherwise the player loses.

Alternately the player chooses the odds, N to 1, then makes a selection. The game is described to the smartcard as a player selection of a number (from 1 to N) followed by a smartcard generated random number in the range 1 to N. If player and smartcard selections match the player wins.

#### **Slots Game Description**

A typical spinning reel slot game has 3 reels, each of 30 symbols with 3 symbols from each reel visible to the player on the screen. This particular game requires the generation of 3 independent random numbers in the range 1 to 30, representing the final stopping positions of each of the 3 reels. A choice made by the player is not applicable in this situation.

The console 12 requests an array of 3 independently selected random numbers from the smartcard, each random number being in the range 1 to 30. The smartcard then returns the result to the console 12 and server 11, as to which of the N possibilities was randomly selected for each selection in the array of M, as described previously. In the case that reel strips have different numbers of stop positions a random number is generated in the appropriate range for each.

#### **Blackjack Game Description**

The game of blackjack is more complex and requires a game specific command. In one implementation of blackjack four cards 201, 202, 203, 204 are selected from a deck, two for the dealer 201, 202 and two for the player 203,204 (See Figure 5). One of the dealer's cards 201 and both player cards are displayed to the player. The other dealer card 202 is hidden. If the

displayed dealer card is an ace the player may choose to take an insurance bet against a dealer blackjack (ie that the hidden card has a count of ten). If the dealer has a blackjack the game ends and the player is paid a win only if they took an insurance bet. If the dealer did not have a blackjack the game continues. Using the usual rules of blackjack the player and dealer choose additional cards from the deck.

First, a shuffled deck of cards is created by generating an array of up to fifty two unique random numbers, each in the range one to fifty two. Next the console 12 reads three of the cards from the array and displays to the player the two player cards 203, 204 and one dealer card 201, leaving the second dealer card 202 displayed facedown. If the displayed dealer card is an ace then using a blackjack specific command the console 12 checks if the second dealer card 202 has a count of ten. The smartcard does not disclose the actual value of the card 202, only if it had a count of ten, or not.

Additional player cards are selected as required from the remaining numbers in the array.

#### **Keno Game Description**

To play Keno the player selects X unique numbers in the range 1 to Z and the console 12 selects Y unique numbers in the range 1 to Z. Typically X = 10, Y = 20, and Z = 80. The console 12 compares the X player selected numbers with the Y console selected numbers and pays the player according to the number that match.

First the player makes a selection of X numbers, which are sent as a message for the server 11 to the smartcard. This proves the player selection before the smartcard generates the console selection

The console 12 then requests the smartcard to generate an array of Y unique numbers in the range 1 to Z and reads the generated numbers. The console 12 reads these numbers and scores the game according to the quantity that match.

#### **Accounting Description**

In the preferred implementation the server performs accounting. Alternatly the smartcard may also be used to perform accounting to allow independant auditing of player gambling and hence provide enhanced security against tampering at the server and help in resolving player disputes. Although the console can keep accounts these are not secure and are therefore of limited value. In this implementation an extra function

description is used for the player bet, so that the smartcard can keep appropriate accounting of bets, wins and losses. These accounts may be read independantly (of the server) from the smartcard but cannot be modified, except by the playing of games.

#### 5 **Download of Code to the Smartcard**

To increase flexibility of the smartcard, code may be downloaded to it from the console 12. Security of the smartcard may be maintained in two ways:

- The code that can be executed is restricted such that no possible code that is downloaded can compromise security. A simple interpreted language could easily satisfy this condition.
- Downloaded code is encrypted such that only an authorised source could have generated it. Alternately a digital signature is used to show that the code is from an approved source.

15 A copy of the code or a one way hash function of it, is sent from the smartcard to the server 11 as a means of verification, with the server confirming the code before it is executed.

#### **Off-line Gaming**

The smartcard may be used in off-line gaming, in which the games may be played without continuous communication with a server 11.

The smartcard is used to generate and record game outcomes of games played without communication to the server 11. When communication is re-established with the server 11 the recorded games are sent to the server for verification and account update.

- 25 • A personal gaming machine comprising of a small hand held console, similar in concept to a "Gameboy™" games console or Radica:™ gaming toy, into which the smartcard is either inserted by the player or embedded by the manufacturer.
- A traditional gaming machine with enhanced security features provided by an embedded smartcard.
- 30 • Gaming on a home or business computer, with the computer as the console 12. Credits may be transferred to the card via a communications link to the casino. The computer may be an Internet terminal and credits transferred via Internet.
- 35 • A plug in module for a game console 12 (eg. Sony Playstation or Nintendo Ultra64), containing the game program (game data) for the console 12 and

the smart card. The module may additionally have a modem for communications.

In an off-line gaming application the number of games played is limited by the non-volatile storage available on the card and therefore data compression techniques may be used to increase the data storage capacity of the card.

Alternately the card may perform verification of the combinations for games itself instead of sending the game descriptions to the server 11. Therefore, the game descriptions are not stored within the card (except for the most recent, as required for game recall), saving space and increasing the number of games that may be played independently of the server 11. The server 11 need only check the total of wins and losses for these games. However, only games with combinations known to the smartcard can be compressed in this way. Any other game combinations played take the usual amount of non-volatile storage. In this implementation both the smartcard and console 12 may store game descriptions intended for later communication to the server 11, but they are not essential for security.

#### **Server Verification Of Games**

The server 11 verifies the games played on the console 12 using the game description message from the smartcard. At least the following checks are made:

- If implemented, the server 11 checks that the random number seed index is valid.
- The game descriptions are consistent with the game type selected.
- The gamble is correct for the game type played.
- The amount bet is valid, including maximum bet, maximum win, etc.
- The game has been fully described and that no messages from the smartcard are missing.
- The server 11 may know the initial random number and hence be able to calculate all future random numbers. It can therefore check the random numbers generated by the smartcard.

For example, a game may allow up to five red/black double ups following a win on a spinning reel game. The server 11 would check that the double up followed a win, that no more than five double ups were played, that each successive double up was played only as a result of a win on the previous game, and that the odds described to the smartcard for each game

were correct. The gamble is not complete until the last double up has been played, and preferably the end of game message has been sent. The server 11 cannot update the account until each of the outcomes is known, in the correct sequence. The game type is therefore different for each of the games played (ie. there are a maximum of six game types played), or another field is added to the game description message to describe which game in the sequence is being played.

Additionally games may be validated by another server 11 whose sole purpose is to verify games. All communications between smartcard and server 11 are copied to the verification server by the game server. The verification server 11 must know the encryption keys used for communication between game server and smartcards 23. A jurisdictional body may, for example, use a verification server 11 to verify the correct operation of the casinos operating within its authority.

Optionally, the encrypted game outcome messages from the smartcard to server include the random numbers used to determine the game outcome. The server verifies that the random numbers produce the specified game outcomes and that the random numbers are valid (either by checking the sequence or statistical tests).

#### **Game Recovery**

In the event of an interruption to the game sequence (power down, communications failure, console failure etc.) it is possible to recover to the same position in the sequence via several means, including;

- The console 12 may have non-volatile storage from which it can recover its previous state of play.
- Outstanding game outcomes in the smartcard are first transmitted to the server 11. Once all game outcomes have been acknowledged, the server 11 has a complete record of the state of game play and the console 12 may then request the current state.
- In an alternate implementation the smartcard stores information sufficient to restore a game in its non-volatile memory, which is passed on request from the smartcard to console 12.

#### **Communications**

Prior to encryption messages may include a message type identification code and a message integrity code (eg. CRC or checksum or secure hash). An additional integrity code added after encryption ensures

successful transmission of data over the communications link between the server 11 and console 12. Therefore, when either the smart card or server 11 detects errors within the encrypted message either may assume that these are not communication errors and that tampering is taking place and hence take appropriate action.

The console 12 may require secure communications with the server 11 separate to that required by the smartcard. This may include the need to download game graphics, sound and code, or player account information. Two methods may be used to accomplish this:

- The servers 11 and console 12 communicate using the smartcard as the encryption means. The console 12 effectively encrypts and decrypts data using the smartcard as the encryption engine.
- The console 12 requests an encryption key from the server 11 for the game session. The key is generated by the server 11, encrypted, and sent to the smartcard. The smartcard decrypts the key and gives it to the console 12 which then uses it for private communications with the server 11.

In a variation on the preferred implementation the console 12 or smartcard suspends games when communication delays with the server 11 exceed a preset time limit, thus ensuring that when the server or network is not operating the console does not play games.

#### **Server To Smart Card Messages**

The server 11 and hence the console 12, may send the following messages to the smartcard, as described elsewhere in this document:

- Send random number seed to the smartcard.
- Request previous game outcomes from the smartcard.
- Request last game outcome from the smartcard.
- Request Card ID (or public key) from the smartcard.
- Send game outcome receipt acknowledge to the smartcard.
- Security poll requiring an immediate and unforgeable response.

Messages from the server 11 are encrypted to prevent eavesdropping or tampering, especially where game outcomes and random numbers are being sent. The server 11 unforgeably identifies itself to the smartcard in its communications by:

- Encrypting messages using the smartcards encryption key, if that key is secret and shared only between the server 11 and smartcard.



- By the server 11 having at least one other encryption key that is a secret known only to the server and smartcard(s).
- By the server 11 having a public key pair and encrypting or signing messages with its private key. The smartcard(s) verify messages with the public key.

To ensure cryptographic freshness and prevent attacks by replaying messages to the smartcard, the message may contain two additional fields (similar to those in smartcard to server messages) in which:

- A randomising code ensures that otherwise identical messages produce different messages when encrypted.
- An index field is used to determine if the message is fresh. Typically this field contains an incrementing 32-bit number and for a message to be valid it must contain a larger index number than the last valid message.

A replay attack might, for example, replay the transmission of a random number seed and cause it to be reused. The optimum game choices could then easily be determined.

#### **Smart Card To Server Messages**

Each command sent to the smartcard used to describe games or generate game outcomes for the console 12 also generates an encrypted and unforgeable message to the server 11 (See Figure 6). Each type of game description or command will cause a different type of message to the server 11 to be generated. Each message is comprised of the card index, game description and optional integrity code (eg. checksum or CRC), which is then encrypted. Therefore four basic messages types are used (message from console 12 to server 11, random number array generation and selection, and the blackjack specific command) with more being added as required.

The card index is used to uniquely identify and sequence each game description sent from console 12 to the smart card, and hence to the server 11. It is automatically incremented for each description and used by the server 11 to determine the order and completeness of all games. Typically the card index is a 32-bit number. For example, if the server 11 receives messages with card indexes of one and three only, it knows that it is missing message two. If a message is lost and needs to be resent to the server 11 the original card index is used and the message is identical, except in an implementation where a randomising number is included in the message. It also knows that game description two was made after description one, and

that three was after two. The card index also prevents tampering by replay attacks in which messages are recorded and resent to the server.

To improve security a randomising code may be included in the encrypted message to ensure that every message from the smartcard is unique, even if it contains otherwise identical data. The randomising code is different for each transmission and would typically be a simple count value or random number. The server 11 ignores the randomising code.

In the alternate implementation where random number seeds are generated by the server 11 the encrypted game outcome message sent from the smartcard to the server also includes the index number that was received with the random number seed used for that game. Including the index ensures that all packets of encrypted data sent back to the server 11 are unique, and that a previous winning game outcome message cannot be resent to the server. The server 11 checks the index number to ensure that this game outcome has not been previously recorded. Old messages or messages for games that have never occurred are evidence of attempted tampering. The random numbers may also be included in this return packet as further confirmation.

Messages to and from the smartcard may be combined reduce the amount of data transmitted and the response time. The response time of the card to game commands is composed of communications times, command processing time, and E<sup>2</sup>PROM write time. Therefore to reduce the response time commands to, and results from, the smartcard may be combined. For example, if the E<sup>2</sup>PROM write time is 5ms, three commands each resulting in writes to E<sup>2</sup>PROM would require at least 15ms. However if the commands are combined only a single 5ms E<sup>2</sup>PROM write is required, saving 10ms.

Attacks on smartcard security may be attempted by timing analysis of smartcard responses to commands from the console 12. Two methods may be used to prevent this:

- A small random time delay may be introduced into all communication from the smartcard to the console 12.
- All responses from the smartcard are delayed to the maximum time that any response could take. All messages therefore take the same amount of time from initiation.

### Random Number Generation

The random numbers used to determine game outcomes are generated either within the smartcard, by the server 11 and sent to the smartcard, or a combination of both.

#### 5 Smartcard Generated Random Numbers

In the preferred implementation the smartcard generates the random numbers required for outcomes from an initial seed. The seed may be set once during configuration/manufacture or updated at various times by the server 11. An implementation that does not allow the server 11 to update the  
10 seed eliminates the possibility that a compromised server can be used to influence or determine the game outcome and hence cheat the system. In an implementation in which the random number seed can be updated the principals set forth for server generated random numbers are also applicable.

An obvious point of attack is the random number generator as it is on  
15 the smartcard. An automated attack can play a large number of games and record the outcomes to try to determine the random number sequence. One or more of the following methods can be used to prevent this attack:

- The random number generator is reseeded from the server 11 periodically. Each time the generator is reseeded the attack analysis would have to  
20 restart.
- When the set limit on the generator is reached without a new seed the smartcard refuses to accept new gambles.
- The delay between generating random numbers can be sufficiently large that it takes too long to determine the sequence by exhaustive trial.
- The generator used is unpredictable, even if its output can be recorded.
- The results output from the smartcard do not indicate the exact random  
25 number generated, only a region in which it falls. Thus the random number is quantised, becoming much harder to determine.
- An automated attack would preferably be made without gambling and thereby losing money. Therefore zero value gambles are either not  
30 allowed or enable a different type of random number generator. If this generator is compromised it is of no help in real games.
- The smartcard generates an internal random number from an initial seed set during manufacture and combines (eg. exclusive or) it with a random  
35 number generated with a seed sent from the server 11. The random

number sequence therefore changes when a new server seed is sent, but a compromised server cannot influence the outcome of games.

#### **Server Generated Random Numbers**

5 In this alternate implementation the server 11 generates random numbers and transmits them to the smartcard prior to the game requiring them. The server may generate all the random numbers required for games, but preferably a single random number seed is used to generate all the random numbers required for a game, reducing the amount of data transferred. For example, a five-reel slot game requires at least five random  
10 numbers, but five random numbers are easily generated from a single random number seed.

In a variation encrypted random seeds must be used within a set time period. Seeds having a limited lifetime, of say 1 hour, shorten the time seeds are available for malicious decrypting. Both encrypted and non-encrypted  
15 'use by dates' are attached to each encrypted seed to enable the console 12 and smartcard to discard seeds that are no longer valid. If a game is played with an invalid seed the server 11 will declare that game void. To prevent tampering whereby messages about losing games are delayed and voided by the server only wins are voided, not losses.

20 In another variation random numbers are continually sent to the smartcard. The smartcard discards all those that it does not use, and optionally informs the server 11 that it has done so.

When the console 12 is initialised for game play it requires random number seeds for the smartcard. These may be stored locally from the  
25 previous game session or will be generated on request, by the server 11. The console 12 stores multiple seeds in a buffer (Figure 7), the quantity being determined by the delay associated in requesting more over the network.  
30

The console 12 or an intermediate level server in an hierarchical system may store seeds and these can be used in a new session. The console  
30 12 is therefore able to immediately supply random number seeds to the smartcard as required and when the console buffer runs low it will request more from the server 11.  
35

Where the random number seeds are sent with a unique index the server 11 may need to determine the last seed used by the smartcard, to  
35 enable the next numbers in the sequence to be generated. In this implementation the server 11 is able to query the smartcard during

initialisation for the sequence number (or entire game outcome message) of the last game played.

In an alternative implementation, random number seeds are sent from the server 11 with an embedded index number, which is returned to the server with the game outcome that was created with that random number. The index number prevents cheating where a random number seed is reused and further enables the server 11 to verify game outcomes. When each new random number seed is received the embedded index is checked against that of the most recent game outcome stored in E<sup>2</sup>PROM. There are three possible outcomes:

- The received index is newer (ie. larger) than that of the last stored game, indicating that it is a new seed, for a new game.
- The received index is the same as the stored index, indicating that the game has already taken place, and the console 12 is so informed. No new gamble choice will be accepted.
- The received index is older (ie. less) than that of the last stored game. This is either the result of an error in the system or an attempt at cheating. This condition is signalled back to the console 12 and the random number seed discarded.

Optionally the index must be the next in the sequence for the smartcard to accept the communication. For example, if the last index was 1000, the next must be 1001. In an alternate implementation is for the next random number seed to be sent in response to the encrypted game outcome for the last game being received by the server 11. However, a delay may occur before the next game if sufficient seeds are not available during subsequent games.

#### **Random Number Server**

In a variation on server generated random numbers and to increase security or control over gaming (by government jurisdiction), a random number server 114 (Figure 8) may be used to create random number seeds. The random number server 114 generates and encrypts seeds using an encryption key not known to the game server(s) 11 and sends them to the game server(s) 11 for distribution to the player consoles 12 and hence smartcards 23. It is therefore not possible for a compromised server to be used to influence or determine the outcome of games.

Random seeds may be encoded such that they can only be used by a specific smartcard, to reduce the possibility of cheating by sending the same seed to multiple smartcards.

The smartcard may generate an acknowledgment message to confirm that it has received the random number seed, which the game (or verification) servers then use to verify the correct operation of the system. When sending the acknowledgment message, the smartcard's card index is incremented, allowing the game (or verification) server to detect when the same random number has been used by multiple smartcards, as acknowledgments cannot be deleted without detection.

Multiple sources of random numbers may be combined within the smartcard to produce the random number to be used to generate the game outcome. The multiple sources may be used for each random number required or periodically used to randomise the sequence further, for example, the server sends the smartcard its own random number together with that from two independent random number servers. The smartcard in addition has its own random number generator seeded during manufacture of the card. The four random numbers are combined (eg. exclusive or) to form the random number(s) used to generate a game outcome. So long as at least one of the sources of a random number is not compromised the game outcome cannot be influenced or predicted.

#### **Security**

Preferably security will be provided in signals transmitted between a game server and a smartcard by use of cryptographic techniques, with the following general principles being employed:

1. All critical transmissions will be encrypted using state-of-the-art encryption schemes;
2. Key management schemes will be used to ensure the security of IDs and keys;
3. The freshness of all transmissions will be ensured and monitored
4. Mutual authentication of principals will be routinely implemented.
5. Cryptographically strong, unbiased pseudo-random number generators will be used through-out the implementation.

In applications where the smartcard is associated with a single player or account (such as Internet gaming) it is an ideal means of identifying the player to the console. Preferably to prevent unauthorised use of the

smartcard players are required to identify themselves to the smartcard in order for it to function, typically using a pin number, password or biometric identification. Multiple accounts (eg. members of a family) may be accessed using a single smartcard and multiple pins, passwords or biometric identification.

Although smartcards are very hard to compromise, they cannot be assumed to be perfectly secure. The potential for breaking the security on the smartcard is acknowledged and the system designed to minimise the damage caused. One or more of the following methods may be used to improve security or detect or limit damage:

- A measure of physical security may be provided when the smartcard is not player accessible. This is only applicable in situations where the player is not required to access the smartcard.
- A different encryption key is used on each smartcard, so that if one smartcard is compromised not all cards are compromised.
- The smartcard issuer (eg. Casino) may retain the ownership rights to cards and can reclaim a smartcard at any time. This allows them to check for physical compromise and remove any cards from use that seem to be suspicious.
- The server 11 can cancel a smartcard. The server 11 will not allow any transactions with that smartcard and may notify its human attendants of any such attempts.
- To prevent stolen cards being used the card ID is programmed when the cards are manufactured. Cards cannot be used without the server 11 knowing the card ID and hence stolen cards cannot (safely) be used.
- When the smartcard detects attempted tampering via erroneous requests it may respond with a randomly generated response message that appears the same as a correct response, but is meaningless.
- When the smartcard detects attempted tampering via erroneous requests it may delay its response to the next request by a significant time. Automated tampering will be slowed down to the point of worthlessness, but normal activity will never encounter delays.
- The server 11 examines the pattern wins and losses associated with individual cards for evidence of tampering. For example, if the return to the player exceeds the statistically likely amount or a statistically

significant distribution exists in the size of bets between wins and losses (ie. large bets on wins and small bets on losses).

- A smartcard that is used from a second location at a distance from the first location that is impossible to reach in the time between uses. This may indicate duplicate smartcards 23.

In some applications where the smartcard is continuously on-line, such as hotel in-room gaming, security may be enhanced by the server 11 periodically establishing secure communications with the smartcard. Only the smartcard is able to correctly respond, hence there is some assurance that the smartcard is not being tampered with. In addition the smartcard may require a similar response from the server 11, to check for itself that tampering is not taking place, and take appropriate action (eg shut down) if it is.

Verifiability of the smartcard may be enhanced by a command causing the smartcard to dump its entire memory contents. Security demands that this command can only be issued by an authorised source, typically a server 11 (in which case the memory dump may be encrypted) or test equipment. Preferably the command is encrypted using the server 11 encryption key or a key reserved especially for this purpose.

#### **Encryption**

The purpose of encryption between server 11 and smartcard 23 is to both hide the data (especially random numbers) and authenticate the source of the message.

Either symmetric or asymmetric (public key) encryption may be used for smartcard to server communications. When public key encryption is used the public key need not be made public (except in an hierarchical system or to identify the smartcard to the server 11).

Preferably each smartcard has its own unique key, so that in the event of a single key (or smartcard) being compromised the entire system is not compromised. The server 11 uses a different key for communicating with each smartcard.

Alternatively, cards use the same key for communication with the server 11, which simplifies key management, but leads to potential security problems

In the hierarchical or verification server system public key or a hybrid encryption scheme may be preferred as it enables a feature where each of the