

- [54] MULTIPLE PROTOCOL ROUTING
- [75] Inventors: **Ross W. Callon**, Bedford; **Radia J. Perlman**, Acton; **Eric C. Rosen**, Arlington, all of Mass.; **John Harper**, Reading, England
- [73] Assignee: **Digital Equipment Corporation**, Maynard, Mass.
- [21] Appl. No.: 577,437
- [22] Filed: Sep. 4, 1990
- [51] Int. Cl.⁵ H04J 3/26; H04L 12/56
- [52] U.S. Cl. 370/60; 370/94.1; 370/54; 370/79; 370/85.13
- [58] Field of Search 370/94.1, 85.13, 85.14, 370/60, 79, 54

[56] References Cited

U.S. PATENT DOCUMENTS

4,706,081	11/1987	Hart et al.	370/61
4,831,620	5/1989	Conway et al.	340/825.05
4,893,307	1/1990	McKay et al.	370/94.1
5,018,133	5/1991	Tsukakoshi et al.	370/85.13
5,031,174	7/1991	Natsume	370/85.14

OTHER PUBLICATIONS

John M. McQuillan et al.; "The New Routing Algorithm for the ARPANET"; *IEEE*; vol. Com-28, No. 5; May 1980.

E. W. Dijkstra; "A Note on Two Problems in Connexion with Graphs"; *Numerische Mathematik*; pp. 269-271 1959.

"Protocol for Providing the Connectionless-Mode Network Service"; ISO 8473; Mar. 1987.

"Intermediate system to Intermediate system Intra-Domain routing exchange protocol for use in Conjunction with the Protocol for providing the Connectionless-mode Network Service"; ISO 10589; Oct. 15, 1989.

"Information processing systems-Telecommunications and information exchange between systems-End system to Intermediate system routing exchange protocol for use in conjunction . . ."; ISO 9542; Mar. 26, 1988.

"Internet Protocol," Darpa Internet Program, Protocol Specification; RFC 791; Sep. 1981.

J. Postel; "Internet Control Message Protocol," Darpa

Internet, Program Protocol Specification; RFC 792; Sep. 1981.

R. Braden, J. Postel; "Requirements for Internet Gateways," RFC 1009; Jun. 1987.

J. Moy; "The OSPF Specification," RFC 1131; Oct. 1989.

C. L. Hedrick, L. Bosack; "An Introduction to IGRP," Jul. 26, 1989.

Callon et al., "Routing in an Internetwork Environment," pp. 4-9.

Shoch et al., "Mutual Encapsulation of Internetwork Protocols," IEN 140, Apr. 1980.

Primary Examiner—Douglas W. Olms
 Assistant Examiner—Min Jung
 Attorney, Agent, or Firm—Fish & Richardson

[57] ABSTRACT

A method for connecting a network so that TCP/IP and OSI 8473 packets may be routed in the same domain. The independence of the addresses is maintained: one device in the network may be assigned only a TCP/IP address, and another device may be assigned only a ISO 8473 address. Furthermore, all of the routers share link state information by using a common link state packet format (such as the ISO 10589 format); thus routes through the network may be computed without regard for the protocols supported by the routers along the route. Where necessary, packets are encapsulated and forwarded through routers which are not capable in the protocol of the packet. In some disclosed embodiments, all of the routers in a given area support a given protocol (or, in fact, have identical capabilities, in which case encapsulation is not required). In these embodiments, the encapsulation is performed by suitable modifications to each router's packet forwarding procedures. In other disclosed embodiments, these topological restrictions are removed, and the network is expanded to support additional protocols. In these embodiments, the Dijkstra algorithm is also modified to generate information on how to encapsulate and forward packets through the network.

24 Claims, 20 Drawing Sheets

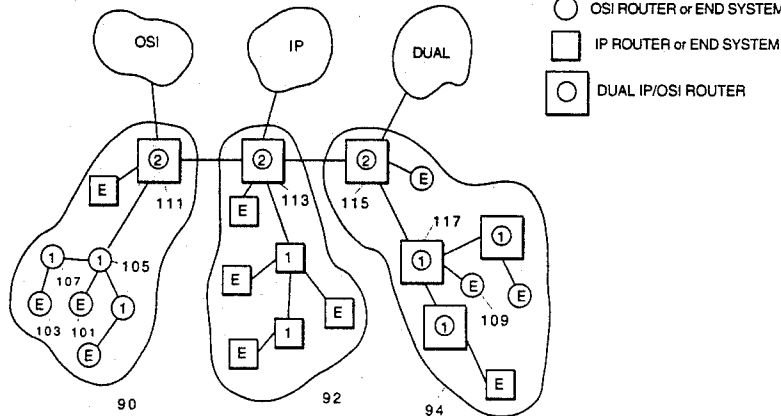

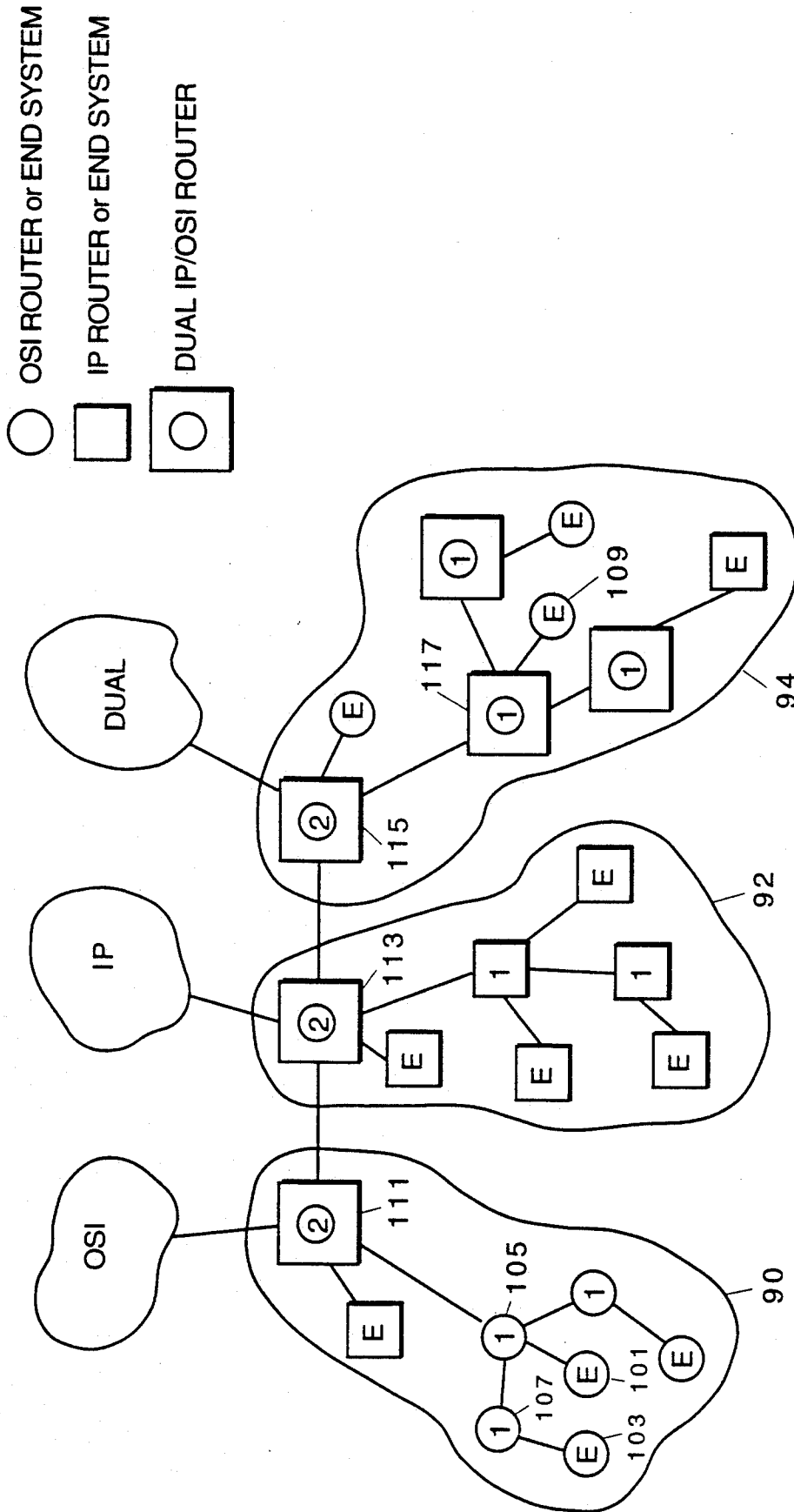

FIG. 1A

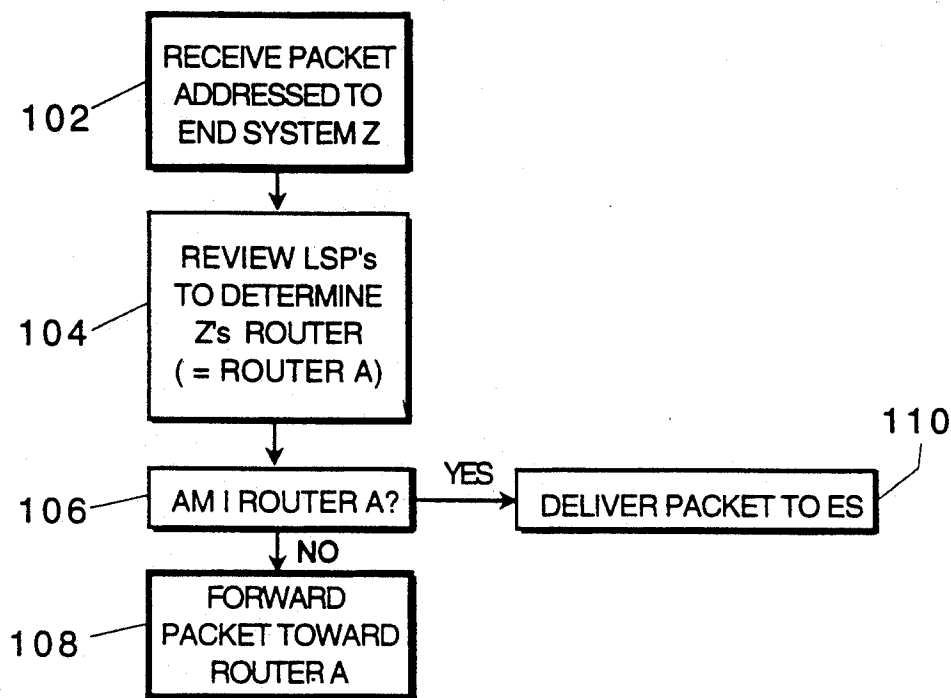

FIG. 1B

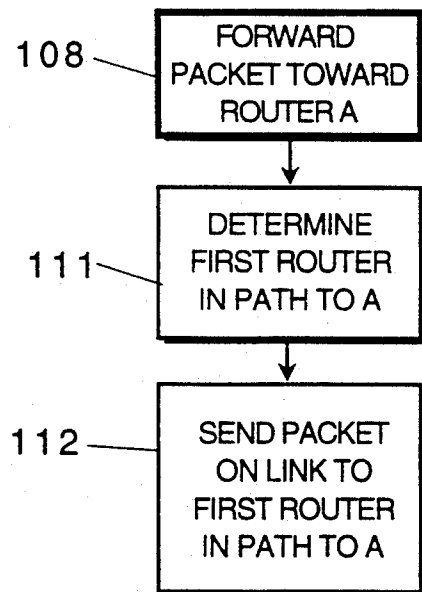

FIG. 1C

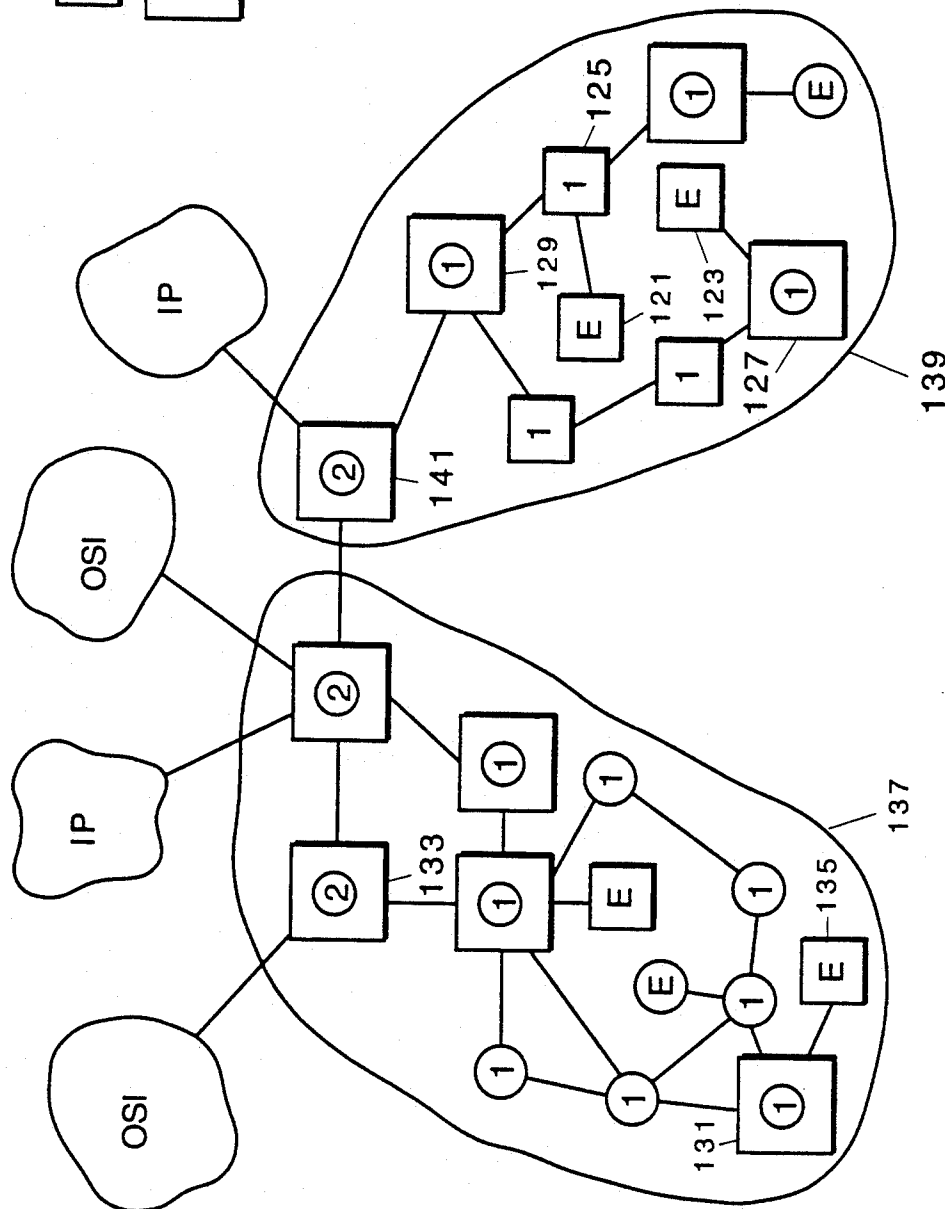
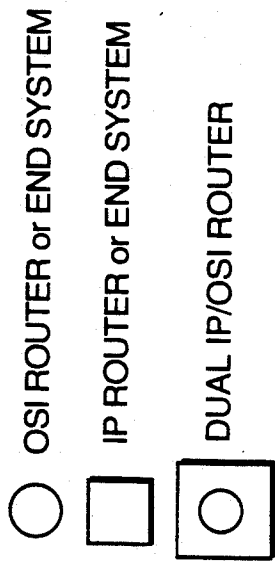

FIG. 2A

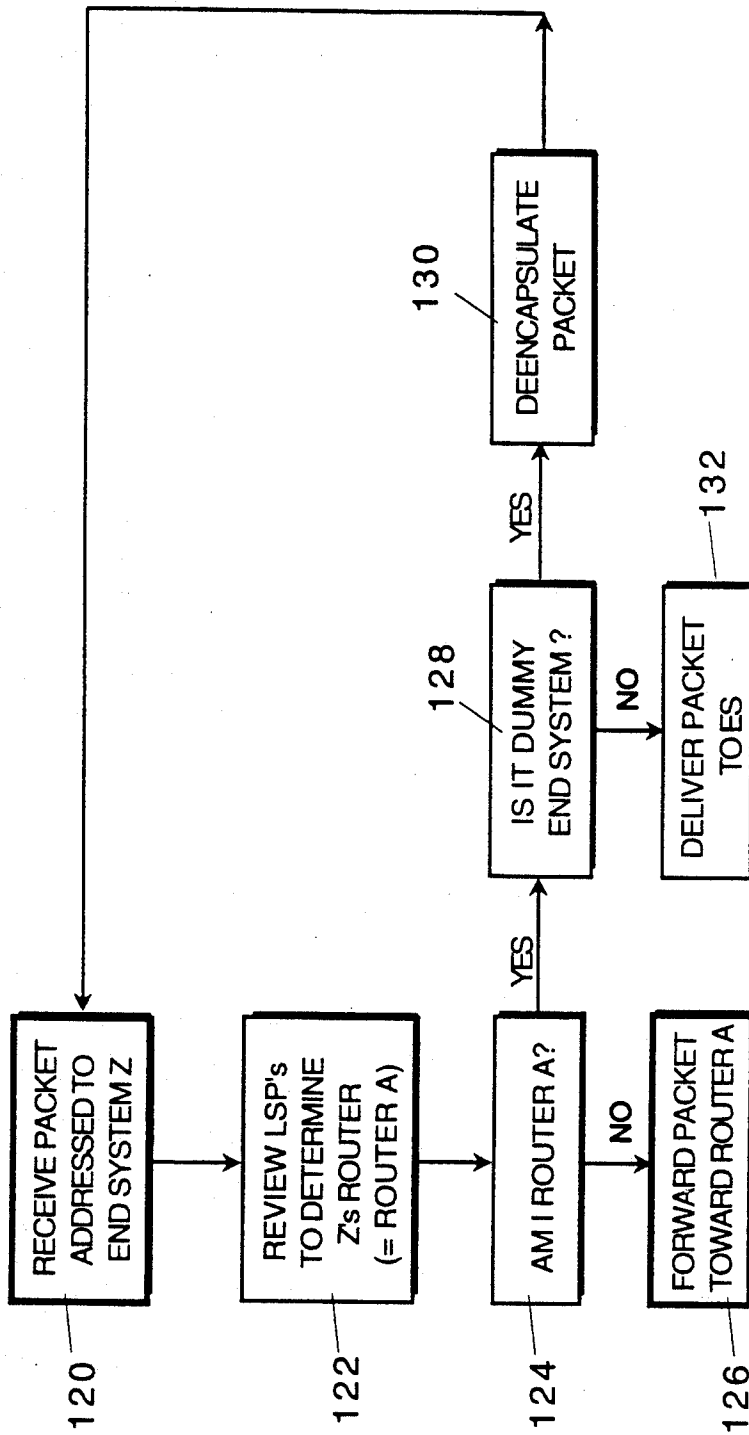

FIG. 2B

Explore Litigation Insights

Docket Alarm provides insights to develop a more informed litigation strategy and the peace of mind of knowing you're on top of things.

Real-Time Litigation Alerts



Keep your litigation team up-to-date with **real-time alerts** and advanced team management tools built for the enterprise, all while greatly reducing PACER spend.

Our comprehensive service means we can handle Federal, State, and Administrative courts across the country.

Advanced Docket Research



With over 230 million records, Docket Alarm's cloud-native docket research platform finds what other services can't. Coverage includes Federal, State, plus PTAB, TTAB, ITC and NLRB decisions, all in one place.

Identify arguments that have been successful in the past with full text, pinpoint searching. Link to case law cited within any court document via Fastcase.

Analytics At Your Fingertips



Learn what happened the last time a particular judge, opposing counsel or company faced cases similar to yours.

Advanced out-of-the-box PTAB and TTAB analytics are always at your fingertips.

API

Docket Alarm offers a powerful API (application programming interface) to developers that want to integrate case filings into their apps.

LAW FIRMS

Build custom dashboards for your attorneys and clients with live data direct from the court.

Automate many repetitive legal tasks like conflict checks, document management, and marketing.

FINANCIAL INSTITUTIONS

Litigation and bankruptcy checks for companies and debtors.

E-DISCOVERY AND LEGAL VENDORS

Sync your system to PACER to automate legal marketing.