



US 20050268298A1

(19) **United States**

(12) **Patent Application Publication**
Hunt et al.

(10) **Pub. No.: US 2005/0268298 A1**

(43) **Pub. Date: Dec. 1, 2005**

(54) **SYSTEM, METHOD AND PROGRAM TO MIGRATE A VIRTUAL MACHINE**

(52) **U.S. Cl. 718/1**

(75) **Inventors: Jennifer A. Hunt, Endicott, NY (US); Steven Shultz, Endicott, NY (US)**

(57) **ABSTRACT**

Correspondence Address:
IBM CORPORATION
IPLAW IQ0A/40-3
1701 NORTH STREET
ENDICOTT, NY 13760 (US)

(73) **Assignee: INTERNATIONAL BUSINESS MACHINES CORPORATION, ARMONK, NY**

(21) **Appl. No.: 10/843,931**

(22) **Filed: May 11, 2004**

Publication Classification

(51) **Int. Cl.⁷ G06F 9/46**

A system, method and program product for migrating a first virtual machine from a first real computer to a second real computer or from a first LPAR to a second LPAR in a same real computer. Before migration, the first virtual machine comprises an operating system and an application in a first private memory private to the first virtual machine. A communication queue of the first virtual machine resides in a shared memory shared by the first and second computers or the first and second LPARs. The operating system and application are copied from the first private memory to the shared memory. The operating system and application are copied from the shared memory to a second private memory private to the first virtual machine in the second computer or second LPAR. Then, the first virtual machine is resumed in the second computer or second LPAR.

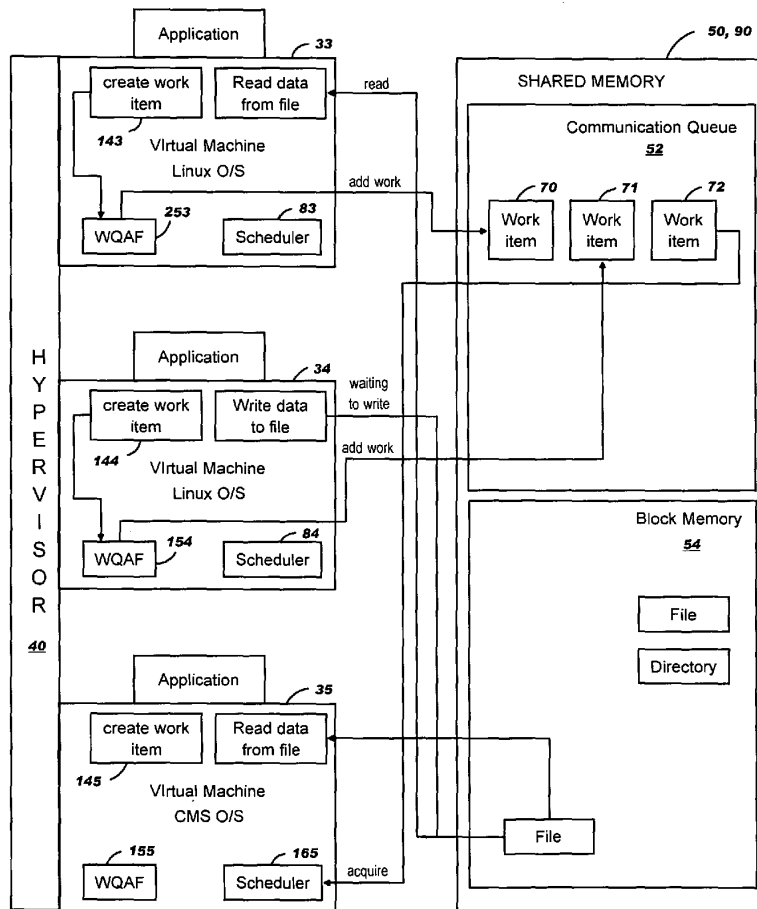

FIG. 1

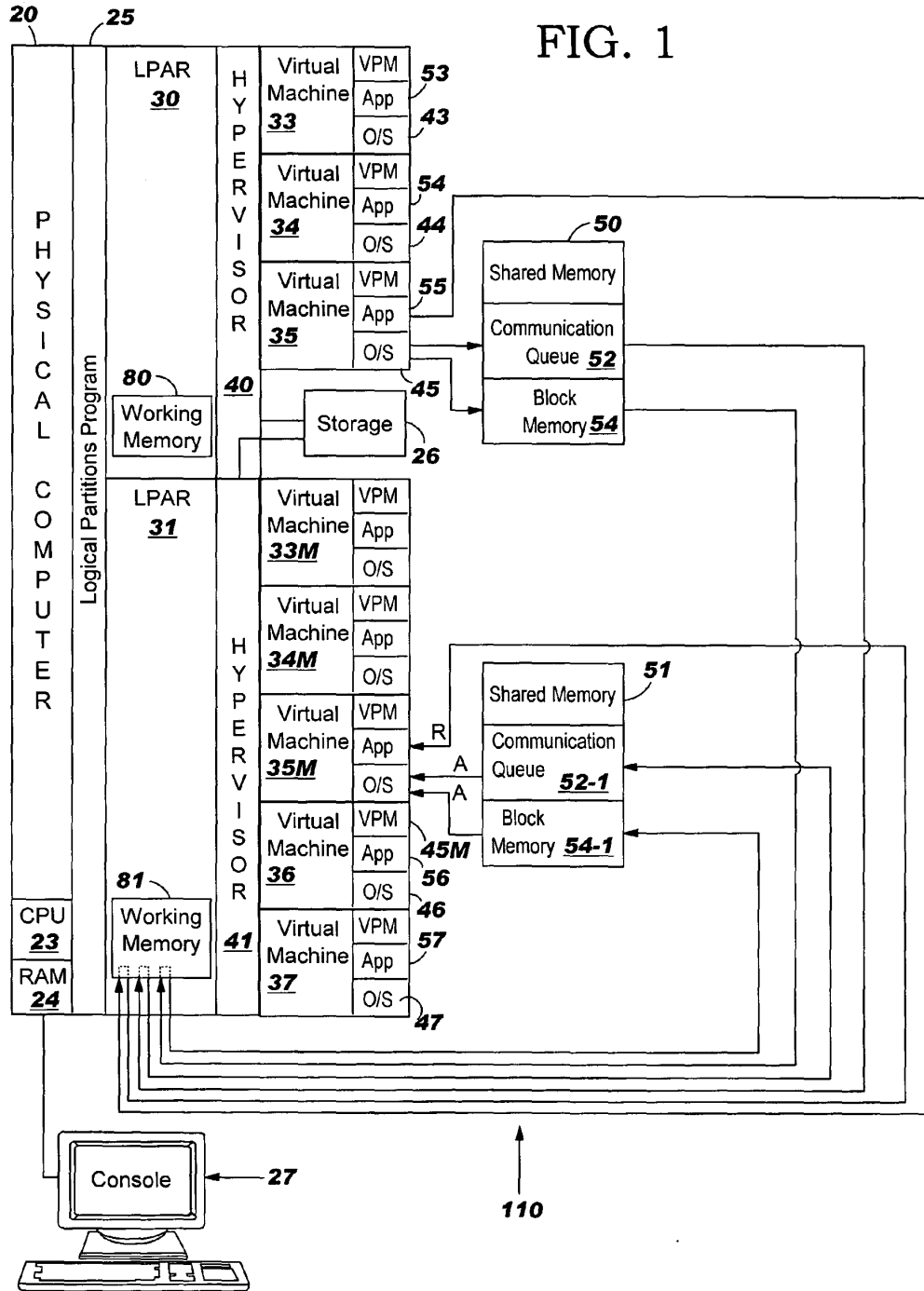
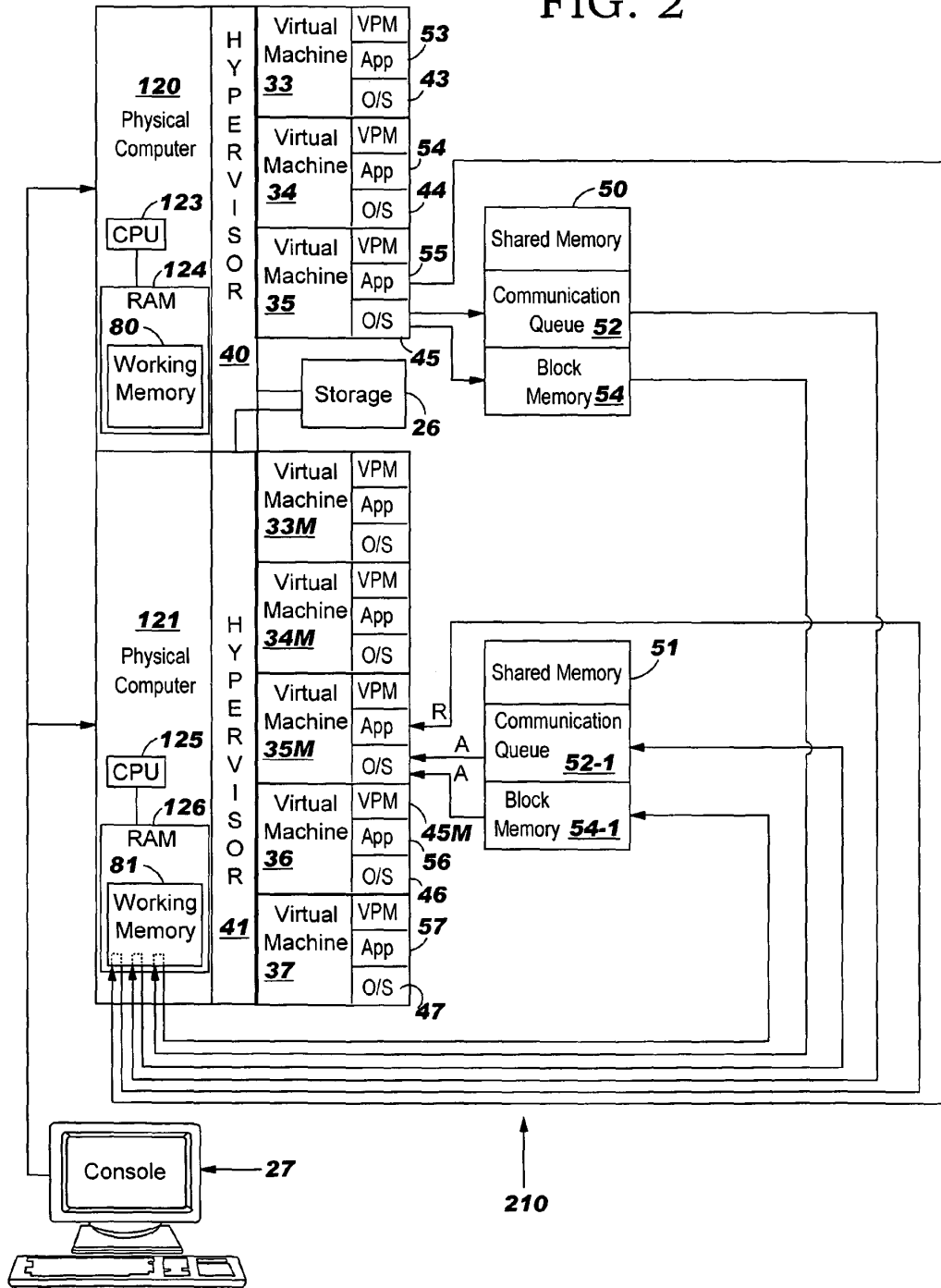

FIG. 2



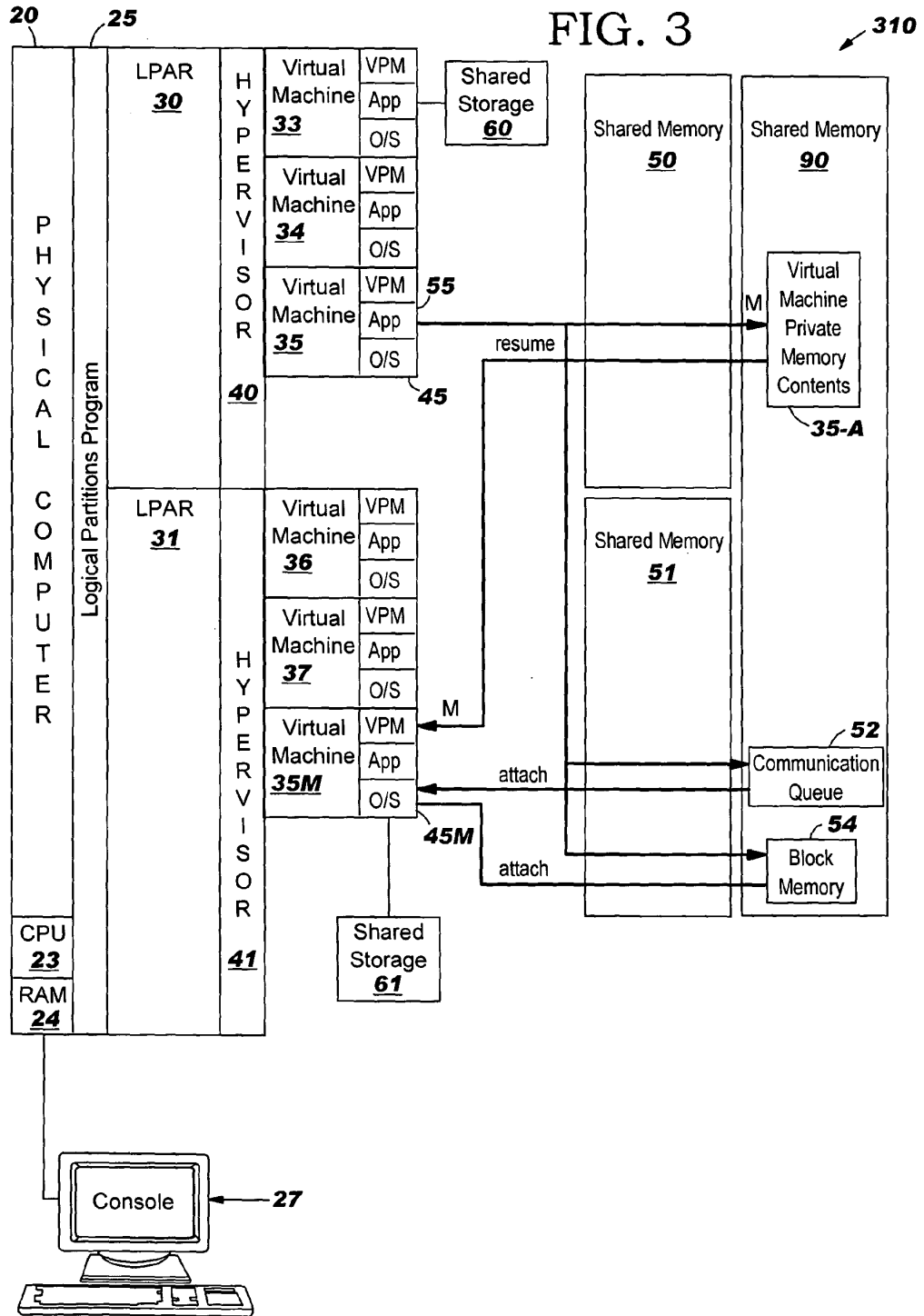
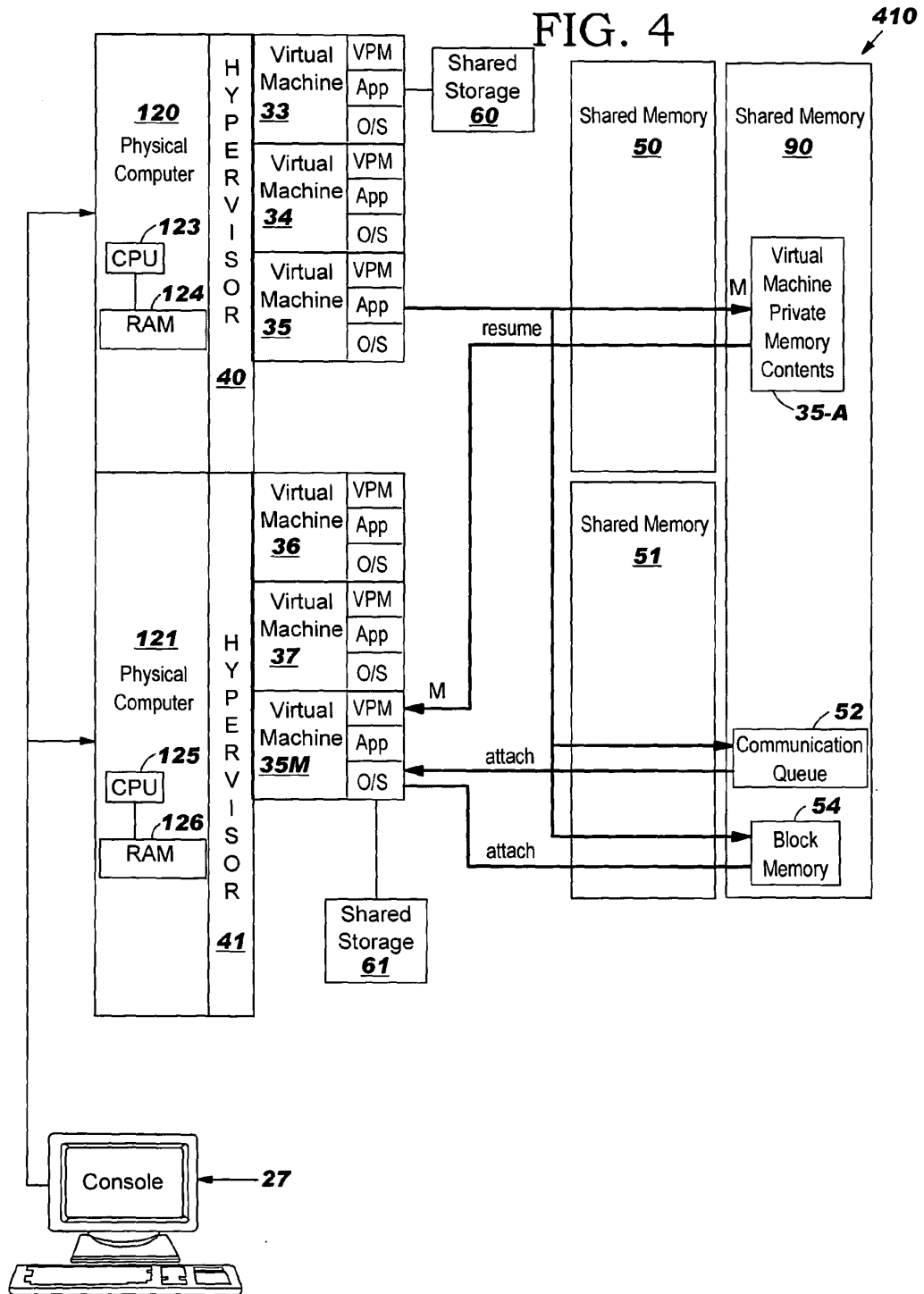

FIG. 4



Explore Litigation Insights

Docket Alarm provides insights to develop a more informed litigation strategy and the peace of mind of knowing you're on top of things.

Real-Time Litigation Alerts



Keep your litigation team up-to-date with **real-time alerts** and advanced team management tools built for the enterprise, all while greatly reducing PACER spend.

Our comprehensive service means we can handle Federal, State, and Administrative courts across the country.

Advanced Docket Research



With over 230 million records, Docket Alarm's cloud-native docket research platform finds what other services can't. Coverage includes Federal, State, plus PTAB, TTAB, ITC and NLRB decisions, all in one place.

Identify arguments that have been successful in the past with full text, pinpoint searching. Link to case law cited within any court document via Fastcase.

Analytics At Your Fingertips



Learn what happened the last time a particular judge, opposing counsel or company faced cases similar to yours.

Advanced out-of-the-box PTAB and TTAB analytics are always at your fingertips.

API

Docket Alarm offers a powerful API (application programming interface) to developers that want to integrate case filings into their apps.

LAW FIRMS

Build custom dashboards for your attorneys and clients with live data direct from the court.

Automate many repetitive legal tasks like conflict checks, document management, and marketing.

FINANCIAL INSTITUTIONS

Litigation and bankruptcy checks for companies and debtors.

E-DISCOVERY AND LEGAL VENDORS

Sync your system to PACER to automate legal marketing.