

block having the same size of the transform unit according to the scan pattern.

**[0103]** The prediction mode decoder 230 reconstructs the intra prediction mode of the current prediction mode on the basis of the intra prediction information and the size information on the current prediction unit received from the entropy decoder 210. The received intra prediction information is restored through an inverse process of the process shown in FIG. 4.

**[0104]** The reference pixel generator 240 generates unavailable reference pixels of the current prediction unit, and adaptively filters the reference pixels according to the intra prediction mode of the current prediction unit received from the prediction mode decoder 230. A method of generating the reference pixels and a method of filtering the reference pixels are the same as those of the reference pixel generator 142 in the intra predictor 140 of FIG. 2.

**[0105]** Specifically, it is determined whether reference pixels of the current prediction unit are available. The reference pixels of the current prediction unit used for intra prediction consist of a corner reference pixel positioned at  $(x = -1, y = -1)$ ,  $2L$  upper reference pixels positioned at  $(x = 0, \dots, \text{and } 2L-1, y = -1)$ , and  $2M$  left reference pixels positioned at  $(x = 0, y = 0, \dots, \text{and } 2M-1)$ . Here,  $L$  is a width of the current prediction unit, and  $M$  is a height of the current prediction unit.

**[0106]** When the reference pixels for generating a prediction block are unavailable or insufficient, reference pixels are generated.

**[0107]** When all the reference pixels are unavailable, reference pixels are generated with a predetermined value.

**[0108]** When some of the reference pixels are unavailable, it is determined whether the unavailable reference pixels exist in only one direction from available pixels or between the available pixels.

**[0109]** When the unavailable reference pixels exist in only one direction from the available pixels, reference pixels are generated by copying the value of an available pixel closest to the unavailable pixel. For example, when the current prediction unit is positioned at an upper boundary of a picture or a slice, the corner reference pixel and the upper reference pixels are unavailable. Thus, in this case, the corner reference pixel and the upper reference pixels can be generated by copying a reference pixel positioned at  $(x = -1, y = 0)$ . Alternatively, reference pixels may be generated using an available reference pixel of the closest position and one or more available reference pixels. For example, when the corner reference pixel having a position  $(x = -1, y = -1)$  and reference pixels at positions  $(x = 0, \dots, \text{and } L-1, y = -1)$  are available and reference pixels at positions  $(x = L, \dots, 2L-1, y = -1)$  are unavailable, reference pixels at the unavailable positions can be generated using change in a difference between a reference pixel at a position  $(x = L-1, y = -1)$  and a corner reference pixel value or another reference pixel value.

**[0110]** When the unavailable reference pixels exist between the available pixels, reference pixels are generated using two available pixels  $p$  and  $q$  adjacent to the unavailable reference pixels. For example, when the corner reference pixel and the  $L$  upper reference pixels positioned at  $(x = 0, \dots, \text{and } L-1, y = -1)$  are unavailable, reference pixels existing between the reference pixel  $p$  at a position  $(x = -1, y = 0)$  and the reference pixel  $q$  at a position  $(x = L, y = -1)$  can be generated using the reference pixels  $p$  and  $q$ .

**[0111]** The generated reference pixel values may be obtained by rounding off an average of the reference pixel  $p$  and the reference pixel  $q$ . Also, the reference pixel values may be generated using change in difference between pixels values of the reference pixel  $p$  and the reference pixel  $q$ . In this case, the reference pixel values may be generated by linear interpolation according to positions corresponding to the generated pixel values or using a weighted average of the two reference pixels.

**[0112]** Meanwhile, when a plurality of prediction units are on an upper side of the current prediction unit, there is a high possibility that a difference between boundary pixels present on both sides of a boundary between two of the upper prediction units will be higher than a difference between adjacent pixels in each upper prediction unit. This results from an error caused by a quantization parameter. It is highly probable that the error will occur in directional intra prediction modes in which the prediction block is generated using two adjacent reference pixels.

**[0113]** In particular, modes (mode numbers 3, 6 and 9) having a direction of  $45^\circ$  with reference to a horizontal or vertical direction of FIG. 3 are most seriously affected. In the vertical and horizontal intra prediction modes (mode numbers 0 and 1), one pixel is used to generate the prediction block, and thus the vertical and horizontal intra prediction modes are slightly affected.

**[0114]** For this reason, a filter (smoothing filter) is applied to the reference pixels in the directional intra prediction modes 3, 6 and 9, and is not applied to the reference pixels in the vertical and horizontal intra prediction modes. In the DC mode out of non-directional modes, the filter is not applied either. For these modes, whether or not to apply the filter may be determined regardless of a size of the current prediction unit.

**[0115]** In directional intra prediction modes existing between the intra prediction mode 3, 6 or 9 and the horizontal or vertical intra prediction mode, the filter (smoothing filter) can be adaptively applied to reference pixels. It is preferable to increase a probability of applying the filter (smoothing filter) as the direction of the directional intra prediction mode is relatively closer to the direction of the intra prediction mode having the direction of  $45^\circ$ . Specifically, when a first directional intra prediction mode is closer in directivity to the intra prediction mode having the direction of  $45^\circ$  than a second directional intra prediction mode, if a filter is applied to the second directional intra prediction mode, the filter is also applied to the first

directional intra prediction mode. On the other hand, if the filter is applied to the first directional intra prediction mode, the filter may or may not be applied to the second directional intra prediction mode.

[0116] There is a high possibility that a change in difference between pixels in a prediction unit of a large size will be less than a change in difference between pixels in a prediction unit of a small size. Thus, the number of directional modes in which the filter is applied may be increased or the stronger filter may be applied as the size of the prediction unit increases. On the other hand, when a prediction unit becomes smaller than a specific size, the filter may not be applied.

[0117] For one example, in the intra prediction mode 3, 6 or 9 having the direction of 45°, a first filter may be applied to a prediction unit having a size equal to or smaller than a first size, and a second filter that is stronger than the first filter may be applied to a prediction unit having a size larger than the first size. The first size may vary according to directional prediction modes.

[0118] For another example, in the intra prediction mode 5 existing between the vertical intra prediction mode and the intra prediction mode 6 having the direction of 45°, no filter may be applied to a prediction unit having a size equal to or smaller than a second size, the first filter may be applied to a prediction unit having a size larger than the second size and equal to or smaller than a third size, and the second filter may be applied to a prediction unit having a size larger than the third size. The second size and the third size may vary according to directional prediction modes.

[0119] The first filter may be a 3-tap filter [1, 2, 1] or a 5-tap filter [1, 2, 4, 2, 1]. The second filter has a greater smoothing effect than the first filter.

[0120] The prediction block generator 250 generates a prediction block according to the intra prediction mode of the current prediction unit received from the prediction mode decoder 230. A method of generating the prediction block is the same as that of the prediction block generator 142 in the intra predictor 140 of FIG. 2.

[0121] That is, in the directional intra prediction mode, the corresponding reference pixels vary according to the intra prediction modes. For example, in the vertical mode, L upper reference pixels positioned at  $(x = 0, \dots, \text{and } L-1, y = -1)$  are used, and in the horizontal mode, L left reference pixels positioned at  $(x = -1, y = 0, \dots, \text{and } L-1)$  are used.

[0122] In non-directional intra prediction modes, the corner pixel, L upper reference pixels positioned at  $(x = 0, \dots, \text{and } L-1, y = -1)$  and L left reference pixels positioned at  $(x = -1, y = 0, \dots, \text{and } L-1)$  are used. The non-directional intra prediction modes are the DC mode and the planar mode.

[0123] In the planar mode, a reference pixel of a prediction block is generated using the corner reference pixel, a left reference pixel and an upper reference pixel. When a reference pixel to be generated is positioned at  $(a, b)$ , the reference pixel of the prediction block  $X(a, b)$

is generated using the corner reference pixel  $C(x = -1, y = -1)$ , an upper reference pixel  $T(x = a, y = -1)$  and a left reference pixel  $L(x = -1, y = b)$ . Specifically,  $X(a, b)$  may be  $L(x = -1, y = b) + T(x = a, y = -1) - C(x = -1, y = -1)$ .

[0124] In the intra prediction mode existing to the right side of the vertical mode (mode number 0) of FIG. 3, there is a possibility that differences between pixels of a lower left region of the generated prediction block and pixels of the original prediction unit will increase if the prediction block is generated using only upper reference pixels. However, when a prediction block is generated using upper reference pixels and left reference pixels for several modes among the modes, the difference can be reduced. This effect is greatest in the intra prediction mode 6. Also in intra prediction modes existing under the horizontal mode (mode number 1) of FIG. 3, same method may be applied, and the effect is greatest in the intra prediction mode 9.

[0125] Thus, in the prediction mode 6 or 9, a prediction pixel may be generated using corresponding (for example, positioned at 45° of the prediction pixel) one upper interpolation reference pixel and one left interpolation reference pixel. The prediction pixel may be generated by linear interpolation of the one upper interpolation reference pixel and the one left interpolation reference pixel or using a rounded off average. Likewise, in a predetermined number of intra prediction modes adjacent to mode 6 or 9, a prediction block may be generated using the left reference pixels and the upper reference pixels. In this case, to reduce complexity, the aforementioned method may not be applied in intra prediction modes having mode numbers greater than a predetermined mode number (for example, 9 or 17). Also, the method may be applied to only a current prediction unit having a size equal to or larger than a predetermined size. The predetermined size is  $8 \times 8$  or  $16 \times 16$ .

[0126] The prediction block post-processor 260 adaptively filters the prediction block generated by the prediction block generator 250 according to the intra prediction mode of the current prediction unit received from the prediction mode decoder 230. The prediction block post-processor may be integrated into the prediction block generator 250. A prediction block filtering method is the same as that of the prediction block post-processor 144 of the intra predictor 140 of FIG. 2.

[0127] That is, to reduce differences in pixel values between a reference pixel and pixels in the prediction block adjacent to the reference pixel, the prediction block filter 260 adaptively filters some or all pixels in the prediction block adjacent to the reference pixel according to the intra prediction mode. The pixels adjacent to the reference pixel exist in the prediction block.

[0128] In the planar mode, pixels in the prediction block adjacent to a reference pixel are generated using the reference pixel, and thus no filter is applied.

[0129] In the DC mode, an average of reference pixels is used to generate prediction pixel, and thus a filter is applied. Different type of filter can be used according to

the size of the prediction unit (the size of the prediction block). In a prediction unit of a large size, a filter that is the same as used in a prediction unit of a small size or a strong filter having a great smoothing effect can be used.

[0130] Meanwhile, in intra prediction modes existing to the right side of the vertical mode (mode number 0) of FIG. 3, if the prediction block is generated using only upper reference pixels, there exists a possibility that a difference between a pixel in the generated prediction block and the corresponding pixel of the original prediction unit will increase as the position of the pixel in the generated prediction block is going down to the under-left region. In particular, the difference remarkably increases in the intra prediction mode 6.

[0131] Likewise, in intra prediction modes existing under the horizontal mode (mode number 1) of FIG. 3, if a prediction block is generated using only left reference pixels, there exists a possibility that a difference between a pixel in the generated prediction block and the corresponding pixel of the original prediction unit will increase as the position of the pixel in the generated prediction block is going to the upper-right region. The difference remarkably increases in the intra prediction mode 9.

[0132] In the vertical mode (mode number 0), a difference between a pixel in the prediction block and the corresponding pixel of the original prediction unit increases as the position of the pixel is going down. In the horizontal mode (mode number 1), a difference between a pixel in the prediction block and the corresponding pixel of the original prediction unit increases as the position of the pixel is going right.

[0133] Therefore, to reduce the difference, some prediction pixels in the prediction block can be adaptively filtered according to the directional intra prediction mode. In this case, the some prediction pixels in the prediction block are filtered using reference pixels in the prediction unit not used for generating the prediction block.

[0134] A region to be filtered may be set differently according to a directional intra prediction mode. As a direction of intra prediction mode gets closer to mode 6 or mode 9, the region to be filtered may become larger or remain the same.

[0135] For one example, when a size of a prediction unit is  $2N \times 2N$  in the intra prediction mode 6, a filter may be applied to only a predetermined number (1~3) of intra prediction modes adjacent to the intra prediction mode 6 among intra prediction modes existing to the right side of the vertical mode (mode number 0). In this case, to reduce complexity, no filter may be applied to the intra prediction mode having a mode number greater than a predetermined mode number (for example, 9 or 17). Also, some pixels in the prediction block may be adaptively filtered according to a size of the prediction unit. As the size of the prediction unit increases, the number of pixels to be filtered may increase or remain the same.

[0136] For another example, in the intra prediction mode 6, the prediction block may not be filtered if the

size of the prediction unit is  $4 \times 4$ . If the size of the prediction unit is  $8 \times 8$  or  $16 \times 16$ , only four lower left boundary pixels of the prediction block among eight pixels positioned at ( $x = 0, y = 0, \dots$ , and 7) may be filtered. If the size of the prediction unit is  $32 \times 32$  or larger, all eight of the boundary pixels may be filtered.

[0137] Strength of filter to be applied to the pixels in the prediction block may also vary according to the size of the prediction unit. As the size of the prediction unit increases, the filter strength may increase or remain the same.

[0138] The image reconstructor 270 receives a prediction block from the prediction block generator 250 or the prediction block filter 260 in units of prediction units according to the intra prediction mode. The image reconstructor 270 receives a residual block reconstructed by the residual signal decoder 220 in units of transform units. The image reconstructor 270 generates a reconstructed image by adding the received prediction block and residual block. The image may be reconstructed in units of coding units.

[0139] While the invention has been shown and described with reference to certain exemplary embodiments thereof, it will be understood by those skilled in the art that various changes in form and details may be made therein without departing from the spirit and scope of the invention as defined by the appended claims.

## Claims

1. An intra prediction decoding apparatus, comprising:

an entropy decoder configured to restore quantized residual coefficients, intra prediction information and size information on a prediction unit from a received bit stream;

a prediction mode decoder configured to restore an intra prediction mode of the current prediction unit on the basis of the intra prediction information and the size information on the current prediction unit received from the entropy decoder; a residual signal decoder configured to restore a residual signal according to the intra prediction mode received from the prediction mode decoder;

a reference pixel generator configured to generate unavailable reference pixels of the current prediction unit, and to adaptively filter the reference pixels on the basis of the intra prediction mode of the current prediction unit received from the prediction mode decoder;

a prediction block generator configured to generate a prediction block using reference pixels corresponding to the intra prediction mode received from the prediction mode decoder;

a prediction block filter configured to adaptively filter the prediction block generated from the pre-

diction block generator according to the intra prediction mode received from the prediction mode decoder; and  
 an image reconstructor configured to receive the prediction block from the prediction block generator or a prediction block filter in units of prediction units according to the intra prediction mode received from the prediction mode decoder, and generate a reconstructed image using a restored residual block received from the residual signal decoder.

2. The intra prediction decoding apparatus of claim 1, wherein the reference pixel generator adaptively filters the reference pixels according to a size of a prediction unit in intra prediction modes having direction between intra prediction mode 3, 6 or 9 having a direction of 45° and the horizontal mode or the vertical mode.
3. The intra prediction decoding apparatus of claim 1, wherein the reference pixel generator applies no filter to reference pixels of a prediction unit smaller than a predetermined size.
4. The intra prediction decoding apparatus of claim 1, wherein, when, among a first directional mode and a second directional mode present between a horizontal mode or a vertical mode and an intra prediction mode 3, 6 or 9 having direction of 45° with respect to the horizontal mode or the vertical mode, the first directional mode has closer directivity to the intra prediction mode having the direction of 45° than the second directional mode, if the reference pixel generator applies a filter to reference pixels of the second directional mode, the reference pixel generator also applies the filter to reference pixels of the first directional mode.
5. The intra prediction decoding apparatus of claim 1, wherein, when the intra prediction mode is a planar mode, the prediction block generator generates predicted pixels of the prediction block using a corner reference pixel, a left reference pixel and an upper reference pixel.
6. The intra prediction decoding apparatus of claim 1, wherein, when the intra prediction mode is a vertical mode, the reference pixel generator does not filter the reference pixels, and the prediction block filter uses reference pixels that have not been used for generating the prediction block to filter some pixels in the prediction block.
7. The intra prediction decoding apparatus of claim 1, wherein, when the intra prediction mode is an intra prediction mode having direction of 45° with respect to a vertical mode (mode number 6) or among a pre-

determined number of intra prediction modes having directivity close to the intra prediction mode, the prediction block generator generates the prediction block using upper reference pixels and left reference pixels.



FIG. 1

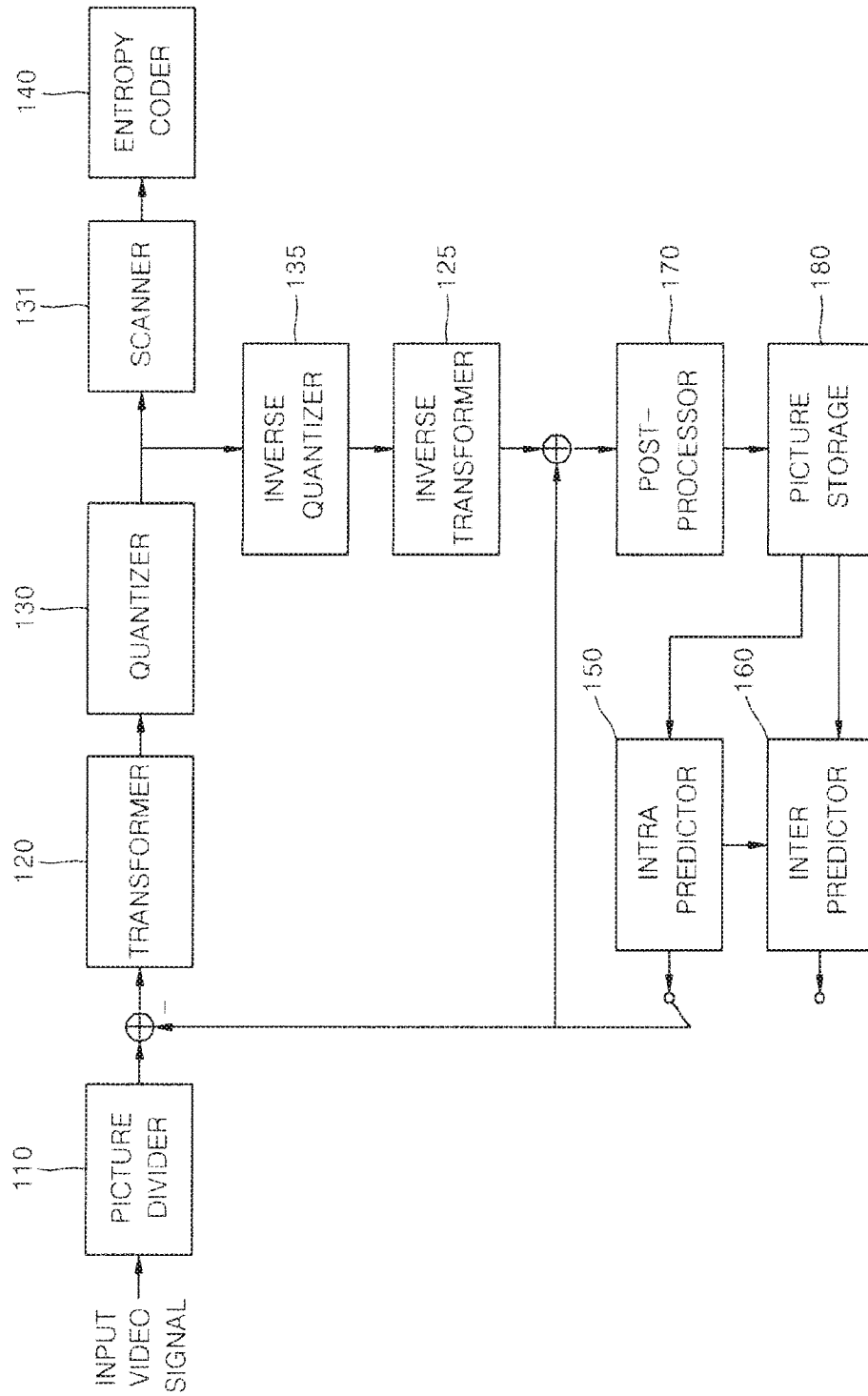

FIG. 2

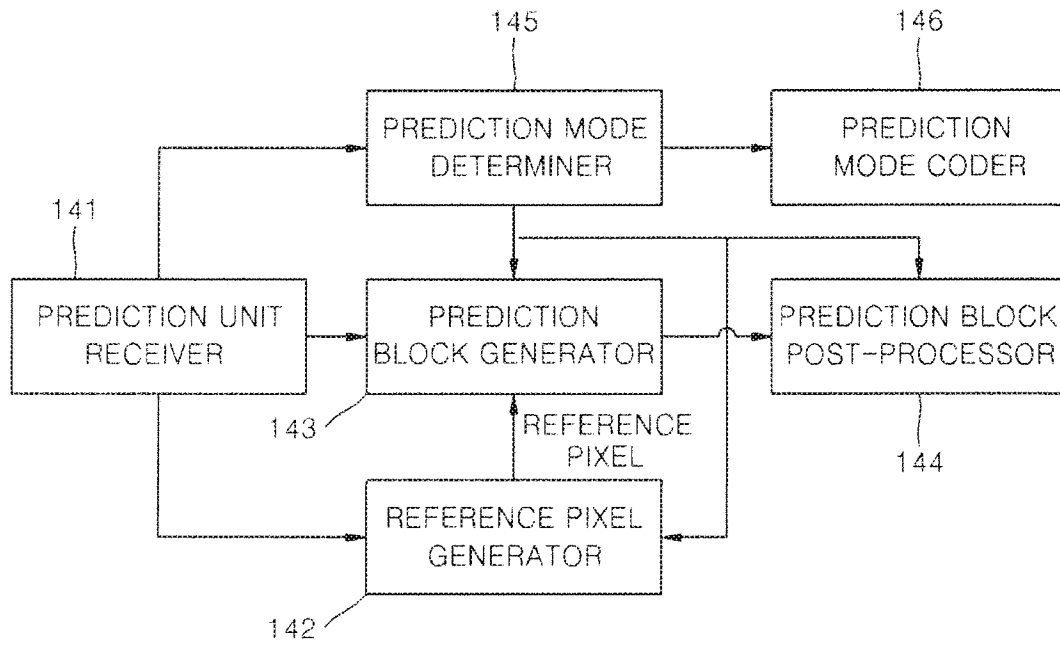

FIG. 3

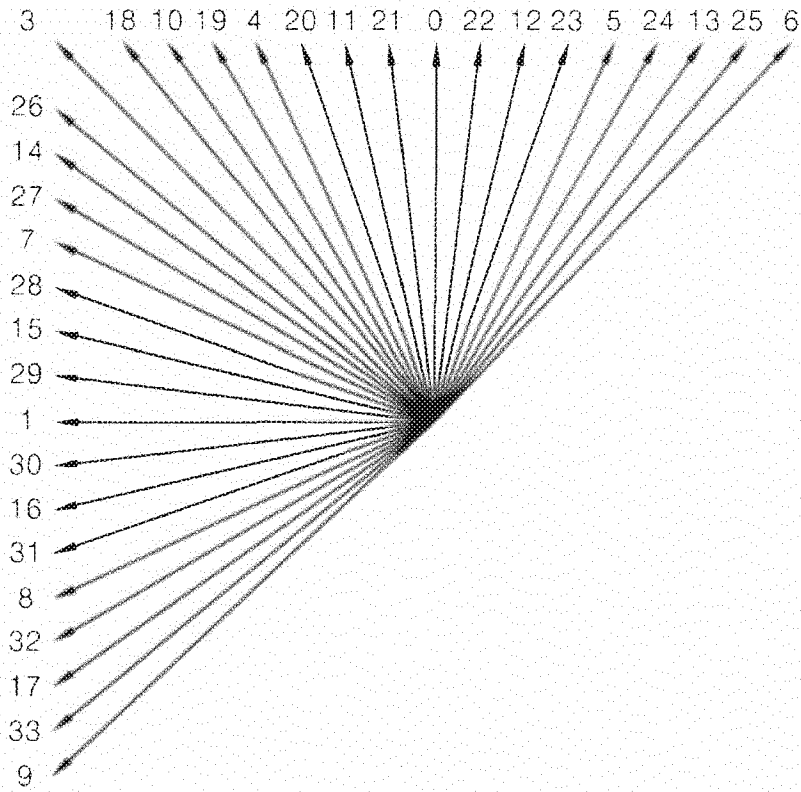

FIG. 4

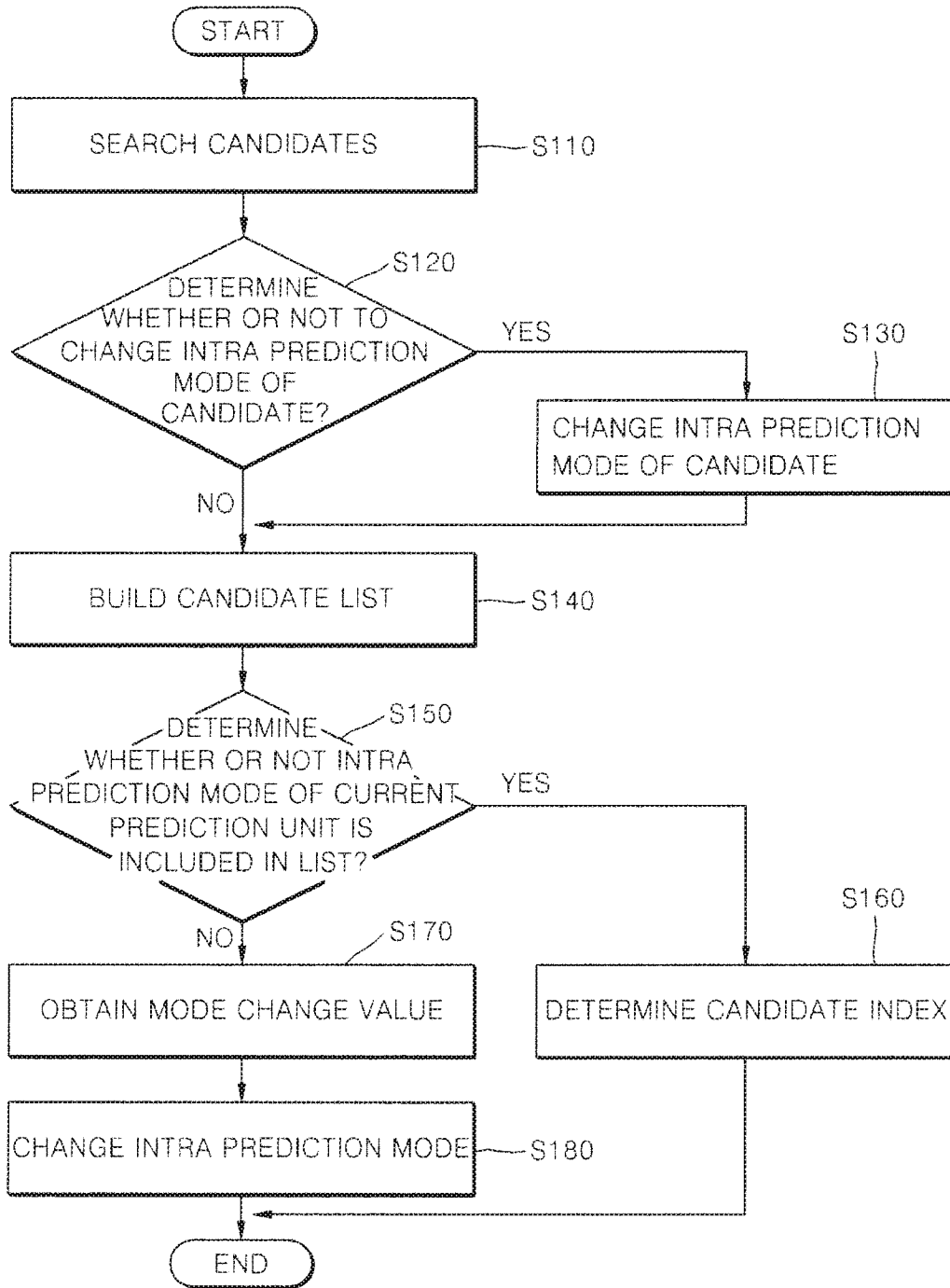
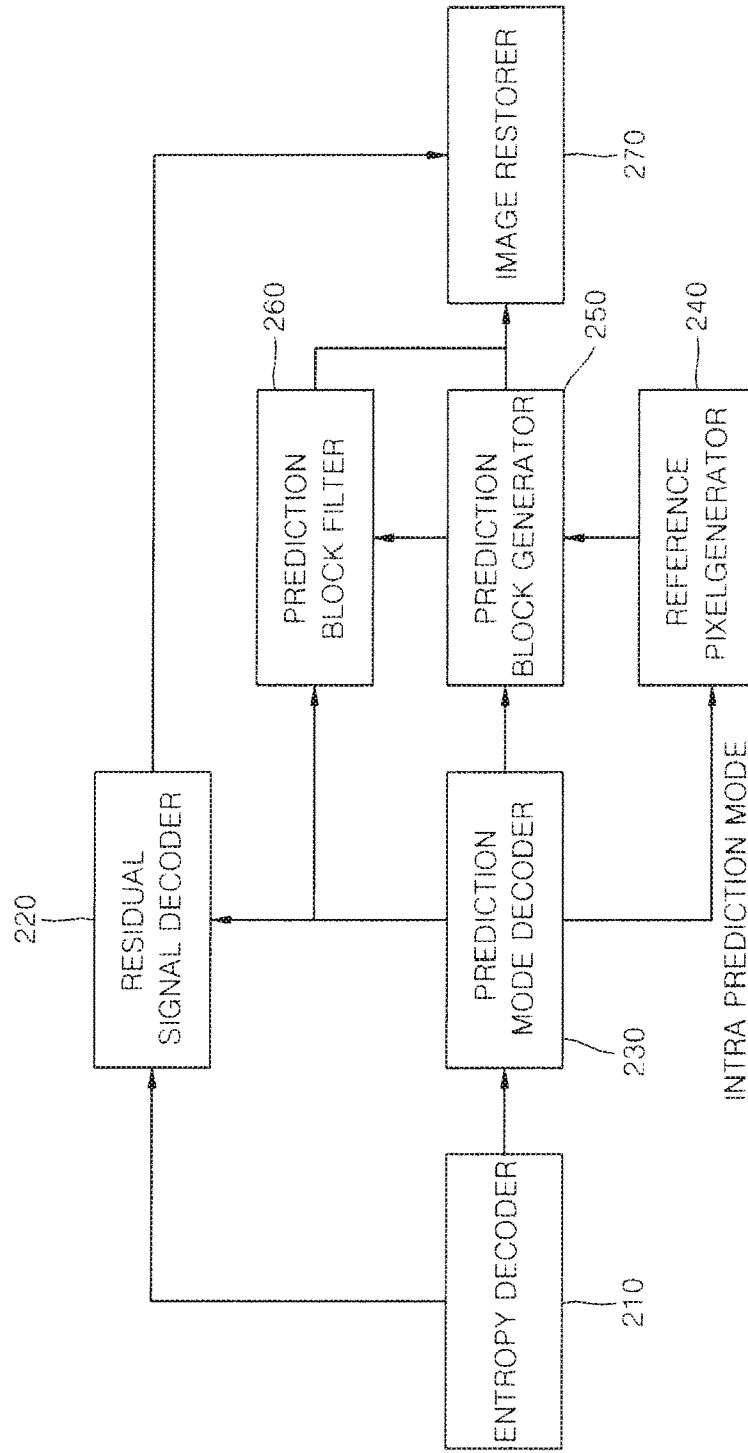
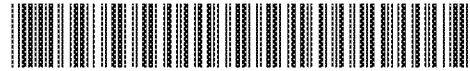

FIG. 5



(19)



(11)

**EP 2 600 614 A2**

(12)

**EUROPEAN PATENT APPLICATION**  
published in accordance with Art. 153(4) EPC

(43) Date of publication:

**05.06.2013 Bulletin 2013/23**

(51) Int Cl.:

**H04N 7/34 (2006.01)**

(21) Application number: **11814798.2**

(86) International application number:

**PCT/KR2011/005592**

(22) Date of filing: **29.07.2011**

(87) International publication number:

**WO 2012/018198 (09.02.2012 Gazette 2012/06)**

(84) Designated Contracting States:

**AL AT BE BG CH CY CZ DE DK EE ES FI FR GB  
GR HR HU IE IS IT LI LT LU LV MC MK MT NL NO  
PL PT RO RS SE SI SK SM TR**

(72) Inventor: **Oh, Soo-mi**

**Seoul 138-908 (KR)**

(74) Representative: **Grünecker, Kinkeldey,**

**Stockmair & Schwanhäusser**

**Leopoldstrasse 4**

**80802 München (DE)**

(30) Priority: **28.06.2011 KR 20110062603**

**31.07.2010 KR 20100074462**

(71) Applicant: **Oh, Soo-mi**

**Seoul 138-908 (KR)**

**(54) PREDICTION BLOCK GENERATING DEVICE**

(57) A prediction block generating device of the present invention determines additional information for generating a prediction block included in an additional information container received, and an intra prediction mode of a current prediction unit using available intra prediction mode candidate information of the current prediction unit, generates reference pixels that are not in an unavailable position for generating an intra prediction block by using available reference pixels, adaptively fil-

ters the reference pixels close to the current prediction unit based on the determined intra prediction mode of the current prediction unit or size information of the current prediction unit, and generates a prediction block of the current prediction unit using the reference pixels corresponding to the determined intra prediction mode of the current prediction unit. Therefore, the present invention can improve image compression ratio by generating the prediction block close to an original image.

FIG. 1

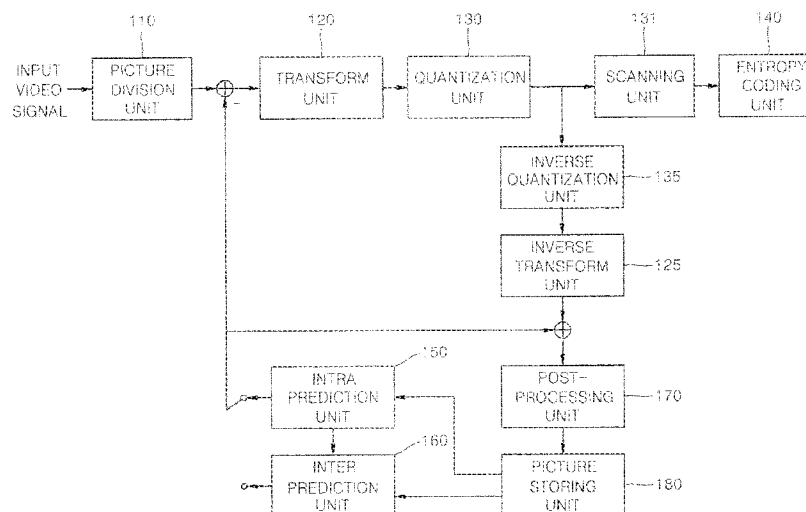

EP 2 600 614 A2

IPR2021-00827

**Description**

[Technical Field]

**[0001]** The present invention relates to a prediction block generating device, and more particularly, to an apparatus of generating a prediction block capable of minimize the amount of coding bits of a residual block.

[Background Art]

**[0002]** In image compression methods such as Motion Picture Experts Group (MPEG)-1, MPEG-2, MPEG-4 and H.264/MPEG-4 Advanced Video Coding (AVC), one picture is divided into macroblocks (MBs) to encode an image. Then, the respective MBs are encoded using inter prediction or intra prediction.

**[0003]** In intra prediction, a current block of a current picture is encoded not using a reference picture, but using values of pixels spatially adjacent to the current block. An intra prediction mode with little distortion is selected by comparing a prediction block generated using the adjacent pixel values with an original MB. Then, using the selected intra prediction mode and the adjacent pixel values, prediction values of the current block are calculated. Differences between the prediction values and pixels values of the original current block are calculated and then encoded through transform coding, quantization and entropy coding. The intra prediction mode is also encoded.

**[0004]** Intra prediction modes are generally classified into 4×4 intra prediction mode, 8×8 intra prediction mode and 16×16 intra prediction mode for luminance components and intra prediction mode for chrominance components.

**[0005]** In 16×16 intra prediction mode according to a prior art, there are four modes of a vertical mode, a horizontal mode, a direct current (DC) mode and a plane mode.

**[0006]** In 4×4 intra prediction according to the prior art, there are nine modes of a vertical mode, a horizontal mode, a DC mode, a diagonal down-left mode, a diagonal down-right mode, a vertical right mode, a vertical left mode, a horizontal-up mode and a horizontal-down mode.

**[0007]** Each prediction mode has indexed according to the frequency of use of the respective modes. The vertical mode of which mode number is 0 shows the highest possibility of being used most frequently for performing intra prediction on a target block, and the horizontal-up mode of which mode number is 8 shows the highest possibility of being used most infrequently.

**[0008]** According to H.264 standards, a current block is encoded using a total of 13 modes, that is, 4 modes of the 4×4 intra prediction and 9 modes of the 16×16 intra prediction. A bit stream of the current block is generated according to an optimal mode among these modes.

**[0009]** However, when some or all values of pixels ad-

acent to current block do not exist or are not already encoded, it is impossible to apply some or all of the intra prediction modes to the current block. Also, when intra prediction is performed by selecting prediction mode among applicable intra mode, a residue signal between a prediction block and the current block becomes large. Therefore, the coding efficiency is degraded.

[Disclosure]

[Technical Problem]

**[0010]** The present invention is directed to an apparatus of generating a prediction block similar to an original block.

[Technical Solution]

**[0011]** One aspect of the present invention provides an apparatus including: an intra prediction mode decoding unit configured to restore an intra prediction mode of a current prediction unit using additional information included in a received additional information container and available intra prediction mode candidate information of the current prediction unit; a reference pixel generating unit configured to generate reference pixels using available reference pixels; a reference pixel filtering unit configured to adaptively filter the reference pixels based on the restored intra prediction mode of the current prediction unit and a size of the current prediction unit; and a prediction block generating unit configured to generate a prediction block of the current prediction unit using the reference pixels corresponding to the restored intra prediction mode.

(Advantageous Effects)

**[0012]** An apparatus according to the present invention generates reference pixels and adaptively filters the reference pixels in order to generate a prediction block minimizing the difference between the prediction block and an original block. Also, by adaptively filtering the prediction block according to intra prediction mode, residual signals become smaller and thus an image compression can be improved.

[Description of Drawings]

**[0013]**

FIG. 1 is a block diagram illustrating a moving picture coding apparatus according to the present invention. FIG. 2 is a flow chart illustrating an operation of a scanning unit according to the present invention. FIG. 3 is a block diagram illustrating a moving picture decoding apparatus according to the present invention. FIG. 4 is a block diagram illustrating an intra predic-

tion unit according to the present invention.

FIG. 5 is a conceptual diagram showing positions of reference pixels used for intra prediction according to the present invention.

FIG. 6 a flow chart illustrating a process of generating reference pixels according to the present invention.

FIG. 7 is a block diagram illustrating an intra prediction unit of a moving picture decoding apparatus according to the present invention.

[Mode for Invention]

**[0014]** Hereinafter, various embodiments of the present invention will be described in detail with reference to the accompanying drawings. However, the present invention is not limited to the exemplary embodiments disclosed below, but can be implemented in various types. Therefore, many other modifications and variations of the present invention are possible, and it is to be understood that within the scope of the disclosed concept, the present invention may be practiced otherwise than as has been specifically described.

**[0015]** For image coding, each picture consists of a plurality of slices, and each slice consists of a plurality of coding units. Since an image of a high-definition (HD) grade or higher has many smooth regions, an image compression can be improved by encoding the image with coding units of larger than an MB of which size is  $16 \times 16$ .

**[0016]** A size of the coding unit according to the present invention may be  $16 \times 16$ ,  $32 \times 32$  or  $64 \times 64$ . A size of the coding unit may also be  $8 \times 8$  or less. A coding unit of the largest size is referred to as a super macroblock (SMB). A size of SMB is indicated by a smallest size of the coding unit and depth information. The depth information indicates a difference value between the size of SMB and the smallest size of the coding unit.

**[0017]** Therefore, coding units to be used for coding pictures may be SMB or sub-block of SMB. The coding units are set to defaults value or are indicated in a sequence header.

**[0018]** A SMB consists of one or more coding units. The SMB has a form of a recursive coding tree so as to include the coding units and a division structure of the coding units. When the SMB is not divided into four sub-coding units, the coding tree may consist of information indicating that the SMB is not divided and one coding unit. When the SMB is divided into four sub-coding units, the coding tree may consist of information indicating that the SMB is divided and four sub-coding trees. Likewise, each sub-coding tree has the same structure as the SMB. However, a coding unit of the smallest coding unit (SCU) size is not divided into sub-coding units.

**[0019]** Meanwhile, each coding unit in the coding tree is subjected to intra prediction or inter prediction in units of the coding unit itself or a sub-block. A unit in which the intra prediction or the inter prediction is performed is referred to as a prediction unit. A size of the prediction unit may be  $2N \times 2N$  or  $N \times N$  for intra prediction. A size of the

prediction unit may be  $2N \times 2N$ ,  $2N \times N$ ,  $N \times 2N$  or  $N \times N$  for inter prediction. Here,  $2N$  denotes horizontal and vertical lengths of a coding unit.

**[0020]** A coding unit includes a prediction mode of the prediction unit and size information (partmode) on the prediction unit. To improve coding efficiency, the prediction mode and the size information may be combined and joint-coded. In this case, each coding unit includes a joint-coded prediction type (pred\_type).

**[0021]** A coding unit includes one or more additional information container. Each additional information container contains additional information required for generating a prediction block of each prediction unit. In intra prediction, the additional information includes encoded intra prediction information. In inter prediction, the additional information includes encoded motion information. The motion information includes a motion vector and a reference picture index.

**[0022]** A coding unit also includes a residual signal container for residual signals of the coding unit. The residual signal container contains one transform tree, one luminance residual signal container and two chrominance residual signal containers. The transform tree indicates whether the residual signals of the transform units in the residual signal container exist or not. The residual signal container consists of a recursive tree structure. The residual signal container for the coding unit is exemplified. If the coding unit is not divided into four sub-coding unit, the residual signal container contains quantization information (residual quantization parameter) and an encoded residual signal. If the coding unit is divided into four sub-coding unit, the residual signal container contains quantization information and four residual signal sub-containers. Each residual signal sub-container has same structure of the residual signal container of the coding unit, but does not contain the quantization information.

**[0023]** Meanwhile, only a case that the coding unit is equally divided into prediction units is described. However, when the above-described equal division is used for an image that has a boundary in a specific direction or at a specific position according to a characteristic, different prediction units are used for similar pieces of data at the boundary, and a residual signal cannot be effectively reduced.

**[0024]** In this case, for compressing a residual signal, it may be more effective to divide SMB or MB in a specific direction according to a shape of the boundary of the image and perform intra or inter prediction.

**[0025]** The simplest adaptive mode is to divide a coding unit into two blocks using a straight line so as to extract statistical dependency of a prediction region on local topography. A boundary of an image is matched to straight line and divided. In this case, dividable directions may be limited to a predetermined number. For example, a method of dividing a block may be limited to four directions of horizontal, vertical, upward diagonal and downward diagonal directions. Also, the division may be lim-



ited to the horizontal and vertical directions only. The number of dividable directions can be three, five, seven and so on. The number of dividable directions may vary according to a size of the coding block. For example, for a coding unit of a large size, the number of dividable directions may be relatively increased.

[0026] In inter prediction, when one coding unit is divided into two prediction units for more adaptive prediction, motion estimation and motion compensation should be performed on each of prediction units. Motion information for each prediction unit is derived, and a residual signal between a prediction block derived from the motion information for each prediction unit is encoded.

[0027] After obtaining residual signals for the respective two prediction blocks divided from one coding unit, the two residual signals may be added to generate one residual signal for one coding unit. The residual signal for one coding unit is transformed and encoded. In this case, it is a high possibility that there will be difference between overall distributions of the residual signals of the respective two prediction blocks with the center of the boundary, and thus a residual signal of one coding unit can be generated by multiplying a value of any one region by a predetermined value. Also, boundary region of the two residual signals may be caused to overlap, and smoothing may be performed on the overlapping boundary region to generate one residual signal.

[0028] In another method, a block may be generated by performing padding according to respective division regions of the block, and encoded. In other words, when a current division region is encoded among the two division regions, one block may be configured by padding another division region constituting the block with a value of the current division region, and then subjected to two-dimensional (2D) transform coding.

[0029] FIG. 1 is a block diagram illustrating a moving picture coding apparatus according to the present invention.

[0030] Referring to FIG. 1, a moving picture coding apparatus 100 according to the present invention includes a picture division unit 110, a transform unit 120, a quantization unit 130, a scanning unit 131, an entropy coding unit 140, an intra prediction unit 150, an inter prediction unit 160, an inverse quantization unit 135, an inverse transform unit 125, a post-processing unit 170, a picture storing unit 180, a subtracter 190 and an adder 195.

[0031] The picture division unit 110 analyzes an input video signal to divide each largest coding unit (LCU) of a picture into coding units each of which has a predetermined size, determine prediction mode of each coding unit, and determines size of prediction unit per each coding unit. The picture division unit 110 sends the prediction unit to be encoded to the intra prediction unit 150 or the inter prediction unit 160 according to the prediction mode. Also, the picture division unit 110 sends the prediction units to be encoded to the subtracter 190.

[0032] The transform unit 120 transforms a residual block. The residual block consists of a residual signal

between an original block inputted and a prediction block generated by the intra prediction unit 150 or the inter prediction unit 160. The residual block may consist of a coding unit. The residual block consisting of a coding unit is divided into optimal transform units and transformed. A transform matrix type may be adaptively determined according to a prediction mode (intra or inter). Also, a residual signal of intra prediction has directivity according to an intra prediction mode, and thus a transform matrix may be adaptively determined according to the intra prediction mode. The transform unit may be transformed by two (horizontal and vertical) one-dimensional (1D) transform matrices. In inter prediction, one predetermined transform matrix type is determined. In intra prediction, there is a high possibility that the residual block will have vertical directivity when the intra prediction mode is horizontal. Thus, a discrete cosine transform (DCT) based integer matrix is applied to the vertical direction, and a discrete sine transform (DST) or Karhunen Loève transform (KLT) based integer matrix is applied to the horizontal direction. When the intra prediction mode is vertical, a DST or KLT based integer matrix is applied to the vertical direction, and a DCT based integer matrix is applied to the horizontal direction. Also, in intra prediction, the transform matrix may be adaptively determined according to a size of the transform units.

[0033] The quantization unit 130 determines a quantization step size for quantizing coefficients of the transformed residual block. The quantization step size is determined per coding unit of a predetermined size or more. The predetermined size may be  $8 \times 8$  or  $16 \times 16$ . Using the determined quantization step size and a quantization matrix determined by a prediction mode, the coefficients of the transform block are quantized. The quantization unit 130 uses quantization step sizes of coding units adjacent to a current coding unit as a quantization step size predictor of the current coding unit. The quantization unit 130 sequentially retrieves coding units in the following scan order; a left coding unit of the current coding unit, an above coding unit of the current coding unit, and an above left coding unit of the current coding unit. Then, the quantization unit 130 generates the quantization step size predictor of the current coding unit using one or two valid quantization step sizes. For example, the first valid quantization step size encountered in the scan order may be determined as the quantization step size predictor. An average of two valid quantization step size retrieved in the scan order may be determined as the quantization step size predictor, and one valid quantization step size is determined as the quantization step size predictor when only the one quantization step size is valid. When the quantization step size predictor is determined, a difference between the quantization step size and the quantization step size predictor is transmitted to the entropy coding unit 140.

[0034] When a slice is divided into coding units, there may be none of a left coding unit, an above coding unit and an above left coding unit of the current coding unit.

But, there may be a previous coding unit of the current coding unit in the coding order in the maximum coding unit. Thus, coding units adjacent to the current coding unit and the previous coding unit of the current coding unit in the coding order in the maximum coding unit may be candidates. In this case, the above scan order may be changed to the following scan order; 1) the left coding unit of the current coding unit, 2) the above coding unit of the current coding unit, 3) the above left coding unit of the current coding unit and 4) the previous coding unit of the current coding unit. The scan order may be changed, or the above left coding unit may be omitted in the scan order.

[0035] The quantized transform block is provided to the inverse quantization unit 135 and the scanning unit 131.

[0036] The scanning unit 131 scans the coefficients of the quantized transform block, thereby converting the coefficients into 1 D quantized coefficients. Since distribution of the coefficients of the transform block after quantization may be dependent on an intra prediction mode, a coefficient scanning pattern is determined according to the intra prediction mode. The coefficient scanning pattern may also be determined according to the size of the transform unit.

[0037] The inverse quantization unit 135 inversely quantizes the quantized coefficients. The inverse transform unit 125 restores a residual block of the spatial domain from the inversely quantized transform coefficients. The adder generates a reconstructed block by adding the residual block reconstructed by the inverse transform unit 125 and the prediction block from the intra prediction unit 150 or the inter prediction unit 160.

[0038] The post-processing unit 170 performs a de-blocking filtering process for removing blocking artifact generated in a reconstructed picture, an adaptive offset application process for complementing a difference between the reconstructed picture and the original image per pixel, and an adaptive loop filter process for complementing a difference between the reconstructed picture and the original image in a coding unit.

[0039] The de-blocking filtering process may be applied to a boundary between prediction units having a predetermined size or more and a boundary between transform units. The predetermined size may be  $8 \times 8$ . The de-blocking filtering process includes a step of determining a boundary to be filtered, a step of determining boundary filtering strength to be applied to the boundary, a step of determining whether or not to apply a de-blocking filter, and a step of selecting a filter to be applied to the boundary when it is determined to apply the de-blocking filter.

[0040] Whether or not to apply the de-blocking filter is determined according to i) whether or not the boundary filtering strength is greater than 0 and ii) whether or not a value indicating the difference between boundary pixels of P block and Q block is smaller than a first reference value determined according to a quantization parameter.

[0041] Two or more filters may exist. When an absolute value of a difference between two pixels adjacent to the block boundary is equal to or larger than a second reference value, a weak filter is selected. The second reference value is determined by the quantization parameter and the boundary filtering strength.

[0042] The adaptive offset application process is intended to reduce a difference (distortion) between a pixel subjected to the de-blocking filter and the original pixel. It may be determined whether or not to perform the adaptive offset application process according to pictures or slices. A picture or slice may be divided into a plurality of offset regions, and an offset mode may be determined per the offset region. There may be four edge offset modes and two band offset modes. In the case of an edge offset type, an edge type to which each pixel belongs is determined, and an offset corresponding to the edge type is applied. The edge type is determined on the basis of distribution of two values of pixels adjacent to a current pixel.

[0043] The adaptive loop filter process may be performed on the basis of a value obtained by comparing an original image and a reconstructed image to which the de-blocking filtering process or the adaptive offset application process is applied. An adaptive loop filter (ALF) is detected through one Laplacian activity value on the basis of a  $4 \times 4$  block. The determined ALF can be applied to all pixels included in a  $4 \times 4$  block or an  $8 \times 8$  block. Whether or not to apply an ALF may be determined according to coding units. A size and coefficients of a loop filter may vary according to each coding unit. A slice header may include information indicating whether or not to apply the ALF to each coding unit, filter coefficient information and filter shape information, and so on. In the case of chrominance components, whether or not to apply the ALF may be determined in picture units. Unlike luminance, the loop filter may have a rectangular shape.

[0044] The picture storing unit 180 receives post-processed image data from the post-processing unit 160, and stores the image in picture units. A picture may be an image in a frame or a field. The picture storing unit 180 has a buffer (not shown) capable of storing a plurality of pictures.

[0045] The inter prediction unit 160 performs motion estimation using one or more reference pictures stored in the picture storing unit 180, and determines reference picture indexes indicating the reference pictures and motion vectors. According to the reference picture index and the motion vector, the inter prediction unit 160 extracts a prediction block corresponding to a prediction unit to be encoded from a reference picture selected among a plurality of reference pictures stored in the picture storing unit 180 and outputs the extracted prediction block.

[0046] The intra prediction unit 150 performs intra prediction using reconstructed pixel values within a current picture. The intra prediction unit 150 receives the current prediction unit to be predictively encoded, selects one of a predetermined number of intra prediction modes, and

performs intra prediction. The predetermined number of intra prediction modes may depend on the size of the current prediction unit. The intra prediction unit adaptively filters the reference pixels to generate the intra prediction block. When some of reference pixels are not available, it is possible to generate the reference pixels at the un-

available positions using one or more available reference pixels.

**[0047]** The entropy coding unit 140 entropy-codes the quantized coefficients quantized by the quantization unit 130, intra prediction information received from the intra prediction unit 150, motion information received from the inter prediction unit 160, and so on.

**[0048]** FIG. 2 is a flow chart illustrating an operation of the scanning unit 131 according to the present invention.

**[0049]** It is determined whether the current quantized coefficients block is divided into a plurality of subsets (S110). The determination is based on a size of the current transform unit. If the size of the current transform unit is larger than a first reference size, the encoded quantized coefficients are divided into a plurality of subsets. The first reference size may be  $4 \times 4$  or  $8 \times 8$ . The first reference size may be transmitted to a decoder by a picture header or a slice header.

**[0050]** When the quantized coefficients block is not divided into a plurality of subsets, a scan pattern to be applied to the quantized coefficients block is determined (S120). The step S120 may be performed prior to the step S110 or regardless of the step S110.

**[0051]** The quantized coefficients of the quantized coefficients block are scanned according to the determined scan pattern (S130). The scan pattern is adaptively determined according to the prediction mode and the intra prediction mode. In inter prediction mode, only one predetermined scan pattern (for example, zigzag scan) can be applied. In intra prediction mode, a scan pattern determined according to the intra prediction mode may be applied. Also, one of a predetermined number of scan patterns may be selected to scan the coefficients, and scan pattern information may be transmitted to the decoder. In intra prediction mode, a scan pattern determined according to the intra prediction mode may be applied. For example, a horizontal scan is applied to a vertical intra prediction mode and a predetermined number of intra prediction modes adjacent to the vertical intra prediction mode. A vertical scan is applied to a horizontal intra prediction mode and a predetermined number of intra prediction modes adjacent to the horizontal intra prediction mode. The predetermined number varies according to a number of allowed intra prediction modes of a prediction unit (or a number of directional intra prediction modes) or a size of a prediction block. For example, if the number of allowable intra prediction modes on the current prediction unit is 16, the predetermined number may be two in each of both directions based on the horizontal or vertical intra prediction mode. If the number of allowable directional intra prediction modes is 33, the predetermined number may be four in each of both directions

based on the horizontal or vertical intra prediction mode. Meanwhile, Zigzag scan is applied to non-directional modes. A non-directional mode may be a direct current (DC) mode or a planar mode.

**[0052]** If it is determined that the quantized coefficients block is divided into a plurality of subsets, the quantized coefficients block is divided into a plurality of subsets (S140). The plurality of subsets consist of one main subset and one or more remaining subsets. The main subset is located at an upper left side and covers a DC coefficient, and the one or more remaining subsets cover region other than the main subset.

**[0053]** A scan pattern to be applied to the subsets is determined (S150). The determined scan pattern is applied to all the subsets. The scan pattern is adaptively determined according to the prediction mode and the intra prediction mode. The step S150 may be performed prior to the step S110 or regardless of the step S110.

**[0054]** When the size of the quantized coefficients block (that is, the size of the transform unit) is larger than a second reference size, the zigzag scan pattern may be applied to the quantized coefficients block. The second reference size is, for example,  $8 \times 8$ . Therefore, the step S150 is performed when the first reference size is smaller than the second reference size.

**[0055]** In inter prediction mode, only one predetermined scan pattern (for example, zigzag scan) can be applied to each subset. In intra prediction mode, the scan pattern is adaptively determined as the same as the step S120.

**[0056]** The quantized coefficients in the subsets may be scanned in a reverse direction. In other words, according to the scan pattern, the quantized coefficients other than 0 may be scanned and entropy-coded in the reverse direction beginning with the last quantized coefficient other than 0 in the subsets.

**[0057]** Next, the quantized coefficients of each subset are scanned according to the scan pattern (S160). The quantized coefficients in each subset are scanned in the reverse direction. That is, the quantized transform coefficients are scanned from a last non-zero coefficient to other non-zero coefficients according to the scan pattern, and entropy-coded.

**[0058]** The zigzag scan may be applied to scan the subsets. The subsets may be scanned beginning with the main subset to the remaining subsets in a forward direction, or can be scanned in the reverse direction. A scan pattern for scanning the subsets may be set the same as a scan pattern for scanning the quantized coefficients in the subsets.

**[0059]** The moving picture coding apparatus 100 according to the present invention transmits information capable of indicating a position of the last non-zero quantized coefficient of the transform unit to a decoder. The moving picture coding apparatus 100 also transmits information capable of indicating a position of the last non-zero quantized coefficient in each subset to the decoder.

**[0060]** FIG. 3 is a block diagram illustrating a moving

picture decoding apparatus according to the present invention.

[0061] The moving picture decoding apparatus according to the present invention includes an entropy decoding unit 210, an inverse scanning unit 220, an inverse quantization unit 230, an inverse transform unit 240, an intra prediction unit 250, an inter prediction unit 260, a post-processing unit 270, a picture storing unit 280, an adder 290 and an intra/inter changing switch 295.

[0062] The entropy decoding unit 210 extracts intra prediction information, inter prediction information and quantized coefficients information from a received bit stream. The entropy decoding unit 210 transmits the inter prediction information to the inter prediction unit 260, intra prediction information to the intra prediction unit 250 and the inverse transform unit 240 and the inverse quantized coefficients information to the inverse scanning unit 220.

[0063] The inverse scanning unit 220 converts the quantized coefficients information into a two dimensional quantized transform block. One of a plurality of inverse scan patterns is selected for the conversion. The inverse scan pattern is selected based on at least one of the prediction mode and the intra prediction mode. An operation of the inverse scanning unit 220 is the same as the inverse operation of the scanning unit 131 of FIG. 1. For example, if a size of a current transform unit to be decoded is larger than the first reference size, each subset are inversely scanned according to the selected inverse scan pattern and an inverse quantized block having a size of the transform unit is generated using the plurality of subsets inversely scanned.

[0064] The inverse quantization unit 230 determines a quantization step size predictor of the current coding unit. The operation to determine the quantization step size predictor is same as the procedure of the quantization unit 130 of FIG. 1. The inverse quantization unit adds the determined quantization step size predictor and a received residual quantization step size to generate a quantization step size of the current coding unit. The inverse quantization unit 230 restores inverse quantized coefficients using a quantization matrix determined by the quantization step size. The quantization matrix varies according to the size of the current block to be restored. The quantization matrix may be selected for a block having the same size on the basis of at least one of a prediction mode and an intra prediction mode of the current block.

[0065] The inverse transform unit 240 inversely transforms the inverse quantized block to restore a residual block. The inverse transform matrix to be applied to the inverse quantized block is adaptively determined according to the prediction mode (intra or inter) and the intra prediction mode. The determination procedure of the inverse transform matrix is the same as the procedure in the transform unit 120 of FIG. 1.

[0066] The adder 290 adds the restored residual block restored by the inverse transform unit 240 and a prediction block generated by the intra prediction unit 250 or

the inter prediction unit 260 to generate a reconstructed image block.

[0067] The intra prediction unit 250 restores the intra prediction mode of the current block based on the intra prediction information received from the entropy decoding unit 210, and generates a prediction block according to the restored intra prediction mode.

[0068] The inter prediction unit 260 restores reference picture indexes and motion vectors based on the inter prediction information received from the entropy decoding unit 210, and generated a prediction block using the reference picture indexes and the motion vectors. When motion compensation with fractional precision is applied, the prediction block is generated using an interpolation filter.

[0069] The post-processing unit 270 operates the same as the post-processing unit 160 of FIG. 1

[0070] The picture storing unit 280 stores the post-processed reconstructed image by the post-processing unit 270.

[0071] FIG. 4 is a block diagram illustrating the intra prediction unit 150 of a moving picture coding unit 100 according to the present invention.

[0072] Referring to FIG. 4, the intra prediction unit 150 includes a reference pixel generating unit 151, a reference pixel filtering unit 152, a prediction mode determining unit 153, a prediction block generating unit 154, a prediction block filtering unit 155 and a prediction mode coding unit 156.

[0073] The reference pixel generating unit 151 determines that it is necessary to generate reference pixels for intra prediction, and generates reference pixels if it is necessary to generate the reference pixels.

[0074] FIG. 5 is a conceptual diagram showing positions of reference pixels used for intra prediction according to the present invention. As shown in FIG. 5, the reference pixels consist of above reference pixels, left reference pixels and a corner reference pixel of the current prediction unit. The above reference pixels of the current prediction unit are pixels (regions C and D) present over double the width of the current prediction unit, and the left reference pixels of the current prediction unit are pixels (regions A and B) present over double the height of the current prediction unit.

[0075] The reference pixel generating unit 151 determines whether the reference pixels are available or not. If one or more reference pixels are not available, the reference pixel generation unit 151 generates reference pixels at the unavailable positions using available reference pixel.

[0076] First, a case in which all reference pixels in any one of upper and left regions of a current prediction unit to be encoded are unavailable will be described.

[0077] For example, when the current prediction unit is located at the upper boundary of a picture or a slice, the above reference pixels (regions C and D) and the corner reference pixel of the current prediction unit do not exist. When the current prediction unit is located at

the left boundary of a picture or a slice, the left reference pixels (regions A and B) and the corner reference pixel do not exist. In those cases, reference pixels are generated by copying the value of an available pixel closest to the unavailable pixel. That is, when the current prediction unit is located at the upper boundary of a picture or a slice, the above reference pixels can be generated by copying the uppermost left reference pixel (that is, a reference pixel located in the uppermost position of region A). When the current prediction unit is located at the left boundary of a picture or a slice, the left reference pixels can be generated by copying the leftmost above reference pixel (that is, a reference pixel located in the leftmost position of region C). The above-mentioned method is applied by default, but the method may vary per sequence, picture or slice if necessary.

[0078] Next, a case in which some of reference pixels in an above or left reference pixels of a current prediction unit to be encoded are unavailable will be described. There are two cases in which 1) available reference pixels are present in only one direction with respect to the unavailable reference pixels, and 2) available reference pixels are present in both directions with respect to the unavailable reference pixels.

Case 1) will be described.

[0079] For example, when the current block is located at the right boundary of a picture or a slice or a LCU, the reference pixels covering area D are not available. Also, when the current block is located at the below boundary of a picture or a slice or a LCU, the reference pixels covering area B are not available. In this case, the reference pixels are generated by copying the values of available pixels closest to the unavailable pixel. Also, the reference pixels are generated using two or more available pixels closest to the unavailable pixel.

Case 2) will be described.

[0080] For example, when the current block is located at the upper boundary of a slice and the above left block of the current block is available, the reference pixels covering area C are not available, but the reference pixels covering areas A and D are available. When available reference pixels are thus present in both directions, one available reference pixel present at the closest position in each direction is selected, and reference pixels at the unavailable positions are generated using the selected reference pixels (i.e., the uppermost reference pixel in region A and the leftmost reference pixel in region D).

[0081] A value obtained by rounding off an average of the two reference pixels (pixels present at the closest positions in the respective directions) may be generated as a reference pixel value. However, when an unavailable reference pixel region is large, there is a high possibility that a step difference will occur between an available pixel and a generated pixel, and thus it is useful to gen-

erate reference pixels using linear interpolation. Specifically, in consideration of a position with respect to two available reference pixels, an unavailable reference pixel at the current position can be generated.

5 [0082] Next, a case in which all reference pixels in above and left sides of a current prediction unit to be encoded are unavailable will be described. For example, when a current prediction unit is adjacent to a left upper boundary of a picture or a slice, there are no available reference pixels.

10 [0083] In this case, some or all reference pixels can be generated using two or more pixels present in the current prediction unit. The number of pixels that are present in the current prediction unit and used for generating the reference pixels may be two or three.

15 [0084] FIG. 6 is a flow chart illustrating a process of generating reference pixels according to the present invention.

[0085] Referring to FIG. 6, the process of generating reference pixels using two pixels is as follows. A left above pixel ○ and one of a right above pixel □, a left below pixel △ and a right below pixel ▽ of the current prediction unit may be used.

20 [0086] When the left above pixel ○ and the right above pixel □ of the current prediction unit are used, the left above pixel and the right above pixel are copied to the corresponding positions on a upper side and the right above pixel and the copied reference pixels are used to generate reference pixels covering area C. The reference pixels are generated using an average or linear interpolation. The reference pixels covering D are generated by copying the right above pixel □ or by using a plurality of the generated above pixels. When the left above pixel ○ and the left below pixel △ of the current prediction unit are used, the same method is applied. When the left above pixel ○ and the right below pixel ▽ are used, the right below pixel ▽ is copied to the corresponding reference pixel position in horizontal direction and vertical direction and then the residual reference pixels are generated as the same as described above.

30 [0087] The process of generating reference pixels using three pixels is as follows. A left above pixel ○, a right above pixel □ and a left below pixel △ of the current prediction unit may be used. The pixels are copied to the corresponding reference pixel position and then the residual reference pixels are generated using the copied pixels. The residual reference pixels are generated as the same as described above.

35 [0088] Meanwhile, when a method as described above is used, the values of the pixels used to generate the reference pixels are transmitted to the decoder. To minimize the amount of bits to be transmitted, the value of the left above pixel ○ and the difference between the value of the left above pixel ○ and the values of other pixels. The value of the left above pixel may be a quantized value or be entropy-coded.

40 [0089] When a slice type is intra (I), it is more effective to generate the reference pixels using two or more pixels.

[0090] Another method of generating reference pixels when all reference pixels in upper and left sides of a current prediction unit to be encoded are unavailable will be described. This method is effective when a slice type is not intra (I).

[0091] First, it is determined whether pixels are present at the same positions as reference pixels of a current prediction unit in a reference picture encoded previously to a current block. When pixels are present, the pixels in the reference picture are copied to generate reference pixels of the current prediction unit.

[0092] When pixels are not present, it is determined whether pixels are present at the closest positions (1 pixel apart) to reference pixels of the current prediction unit. When pixels are present, the pixels are copied and used as the reference pixels of the current prediction unit.

[0093] The reference pixel filtering unit 152 adaptively filters reference pixels of the current prediction unit. Low-pass filter is applied to smooth a variance of pixel values between the reference pixels. The low-pass filter may be a 3-tap filter [1, 2, 1] or a 5-tap filter [1, 2, 4, 2, 1].

[0094] The filter may be adaptively applied according to a size of the current block. If the size of the current block is equal to or smaller than a predetermined size, the filter may not be applied. The predetermined size may be 4x4.

[0095] The filter may also be adaptively applied according to a size of the current block and intra prediction mode.

[0096] If intra prediction mode is the horizontal mode or the vertical mode, pixels of a prediction block are generated using one reference pixel. Therefore, a filter is not applied in the horizontal mode and the vertical mode. In the DC mode, a prediction pixel is generated using average of the reference pixels. Therefore, a filter is not applied in the DC mode because the prediction pixel is not affected by the difference between the reference pixels.

[0097] In the intra prediction mode 3, 6 or 9 having a direction of 45° with reference to the horizontal or vertical direction, a filter is applied regardless of the size of the prediction unit or applied when the current block is larger than a smallest prediction unit. A first filter may be applied to a prediction unit having a size smaller than a predetermined size, and a second filter stronger than the first filter may be applied to a prediction unit having a size equal to or larger than the predetermined size. The predetermined size may be 16x16.

[0098] In the intra prediction modes other than the vertical mode, the horizontal mode, the DC mode and the intra prediction mode 3, 6 and 9, a filter may be adaptively applied according to the size of the current prediction unit and the intra prediction mode. However, in the planar mode, filtering of reference pixels may be performed.

[0099] Also, the filter may not be applied to some or all reference pixels generated through linear combination.

[0100] The prediction block generating unit 153 generates a prediction block corresponding to the intra pre-

dition mode. The prediction block is generated using the reference pixels or linear combination of the reference pixels based on the intra prediction mode. The reference pixels to be used to generate the prediction block may be filtered by the reference pixel filtering unit 152.

[0101] The prediction block filtering unit 154 adaptively filters the generated prediction block according to the intra prediction mode to minimize the residual signal between the prediction block and the current block to be encoded. The difference between a reference pixel and a prediction pixel adjacent to the reference pixel varies according to the intra prediction mode. Therefore, filtering of the prediction pixel adjacent to the reference pixel enables the difference to be decreased.

[0102] In the DC mode, the prediction block consists of averages of reference pixels, and a step difference may occur between pixels in a prediction block adjacent to the reference pixels. Therefore, the prediction pixels of upper line and left line which are adjacent to the reference pixels are filtered using the reference pixels. The upper left prediction pixel adjacent two reference pixels (the upper reference pixel and the left reference pixel) is filtered by 3-tap filter. The other prediction pixels (pixels of upper line and pixels of left line in the prediction block) and adjacent to one reference pixel are filtered by 2-tap filter.

[0103] In the vertical mode (mode 0), the diagonal down-left mode (mode 6), and the intra prediction modes (modes 22, 12, 23, 5, 24, 13, 25) between the mode 0 and mode 6, a prediction block is generated using only above reference pixels of the prediction unit. Therefore, the difference between a reference pixel and a prediction pixel adjacent to the reference pixel and of the upper line in the prediction block may be larger as the position of the prediction pixel goes down.

[0104] Also, in the horizontal mode (mode 1), the diagonal up-right mode (mode 9), and the intra prediction modes (modes 30, 16, 31, 8, 32, 17, 33) between the mode 1 and mode 9, a prediction block is generated using only left reference pixels. Therefore, the difference between a reference pixel and a prediction pixel adjacent to the reference pixel and of the upper line in the prediction block may be larger as the position of the prediction pixel goes right.

[0105] Accordingly, some prediction pixels of the prediction block may be filtered for compensate the difference in directional intra prediction mode other than DC mode.

[0106] In the mode 6, all or some prediction pixels adjacent to the left reference pixel and of left line in the prediction block are filtered. The pixels of the left line may be, for example, N/2 pixels in a lower portion of the left line. Here, N is the height of the current prediction unit.

[0107] In the mode 9, all or some prediction pixels adjacent to the above reference pixel and of upper line in the prediction block are filtered. The pixels of the upper line may be, for example, M/2 pixels in a right portion of the upper line. Here, M is the width of the current predic-

tion unit.

[0108] In a predetermined number of directional intra prediction modes which are closer to the mode 6 and exist between mode 0 and mode 6, the same filtering method as in the mode 6 can be used. In this case, the farther from mode number 6 a mode is, the smaller or equal the number of pixels to be filtered may be.

[0109] The same filtering method can be used in the directional intra prediction modes between mode 1 and mode 9.

[0110] Meanwhile, the filter is adaptively applied according to the size of the current prediction unit. For example, a filter is not applied to a predetermined size or less according to the intra prediction mode.

[0111] The prediction block filtering unit 154 may be integrated into the prediction block generating unit 153. Also, a prediction block may be generated to bring about effects of the prediction block filtering. In this case, the prediction block is generated by using the combination of the generating operation and the filtering operation.

[0112] The intra prediction mode determining unit 155 determines the intra prediction mode of a current prediction unit using reference pixels. The intra prediction mode determining unit 155 selects one intra prediction mode in which the amount of coding bits of a residual block is minimized as the intra prediction mode of the current prediction unit. To generate a residual block, a prediction block is generated according to each intra prediction mode. The prediction block may be generated by using the reference pixels filtered by the reference pixel filtering unit or may be a block filtered by the prediction block filtering unit 154.

[0113] The prediction block transmitting unit 157 transmits the prediction block generated based on the intra prediction mode by the prediction mode determining unit 155 to the subtracter.

[0114] The prediction mode coding unit 156 encodes the intra prediction mode of the current prediction unit determined by the intra prediction mode determining unit 155. The intra prediction mode coding unit 156 may be integrated into the intra prediction unit 150 or into the entropy coding unit 140.

[0115] The prediction mode coding unit 156 encodes the intra prediction mode of the current prediction unit using an above intra prediction mode of the current prediction unit and a left intra prediction mode of the current prediction unit.

[0116] First, the above intra prediction mode and the left intra prediction mode of the current prediction unit are derived. When there exist a plurality of above prediction units of the current prediction unit, the plurality of above prediction units are scanned in a predetermined direction (for example, from right to left) to determine the intra prediction mode of a first available prediction unit as an above intra prediction mode. Also, when there exist a plurality of left prediction units of the current prediction unit, the plurality of left prediction units are scanned in a predetermined direction (for example, from bottom to top)

to determine the intra prediction mode of a first available prediction unit as a left intra prediction mode. Alternatively, among a plurality of available prediction units, the intra prediction mode of an available prediction unit having the lowest intra prediction mode number may be set as an above intra prediction mode.

[0117] When the above intra prediction mode or the left intra prediction mode is not available, the DC mode (mode 2) may be set to as the above intra prediction mode or the left intra prediction mode. The above intra prediction mode or the left intra prediction mode is treated as unavailable when there does not exist a corresponding prediction unit.

[0118] Next, the above intra prediction mode or the left intra prediction mode is converted into one of the predetermined number of intra prediction modes when the above intra prediction mode number or the left intra prediction mode number is equal to or greater than the number of intra prediction modes permissible for the current prediction unit. The predetermined number may vary according to a size of the current prediction unit. For example, when the size of the current prediction unit is  $4 \times 4$ , the intra prediction mode is converted into one of nine modes (mode 0 to mode 8), and when the size of the current prediction unit is  $64 \times 64$ , the intra prediction mode is mapped into one of three modes (mode 0 to mode 2). The intra prediction mode may be converted into one of the intra prediction modes permissible for the current prediction unit.

[0119] Next, if the intra prediction mode of the current prediction unit is the same as any one of the above and left intra prediction modes, a flag indicating that the intra prediction mode of the current prediction unit is the same as any one of the above and left intra prediction modes and a flag indicating one of the above and left intra prediction modes are transmitted to the decoder. In this case, if the above and left intra prediction modes are same, the flag indicating one of the above and left intra prediction modes can be omitted. Also, if only one of the above and left intra prediction modes is available and the available intra prediction mode is same with the intra prediction mode of the current prediction block, the flag indicating one of the above and left intra prediction modes can be omitted.

[0120] But, if the intra prediction mode of the current prediction unit is not the same as any one of the above and left intra prediction modes, the intra prediction mode number of the current prediction unit is compared with the above intra prediction mode number and the left intra prediction mode number. The number of cases in which the left or upper intra prediction mode numbers is not greater than the intra prediction mode number of the current prediction unit is calculated, and a value obtained by subtracting the number of cases from the intra prediction mode number of the current prediction unit is determined as a final intra prediction mode number of the current prediction unit to be transmitted. Here, when the left and upper intra prediction mode numbers are identical,



the left and upper intra prediction modes are regarded as one.

[0121] According to whether or not the upper and left intra prediction modes are identical, a table for entropy-coding the determined final intra prediction mode is determined.

[0122] FIG. 7 is a block diagram illustrating the intra prediction unit 250 of a moving picture decoding apparatus 200 according to the present invention.

[0123] The intra prediction unit 250 according to the present invention includes a prediction mode decoding unit 251, a reference pixel generating unit 252, a reference pixel filtering unit 253, a prediction block generating unit 254, a prediction block filtering unit 255 and a prediction block transmitting unit 256.

[0124] The prediction mode decoding unit 251 restores the intra prediction mode of a current prediction unit as follows.

[0125] First, the prediction mode decoding unit 251 receives additional information included in the additional information container for generating a prediction block. The additional information includes a prediction flag and residual prediction information. The prediction flag indicates whether the intra prediction mode of the current prediction unit is the same as one of intra prediction modes of adjacent prediction units. The residual prediction information includes information determined by the prediction flag. If the prediction flag is 1, the residual prediction information may include an index of the intra prediction mode candidate. The index of the intra prediction mode designates the intra prediction mode candidate. If the prediction flag is 0, the residual information may include residual intra prediction mode number.

[0126] Intra prediction mode candidates of the current prediction unit are derived. The intra prediction mode candidates are derived using intra prediction modes of adjacent prediction units. For convenience, a case in which the intra prediction mode candidate of the current prediction unit are limited to upper and left intra prediction modes will be described. When there are a plurality of above prediction units or a plurality of left prediction units, the intra prediction mode of the above or left prediction unit is determined as the same as described in the operation of the intra prediction encoding unit 156 of the coding apparatus 100. Also, when the mode number of an available intra prediction mode candidate is equal to or greater than the number of intra prediction modes permissible for the current prediction unit, the available intra prediction mode candidate is converted into one of the permissible modes for the current prediction unit as described in the intra prediction encoding unit 156.

[0127] Next, when the received prediction flag indicates that the current prediction unit has the same intra prediction mode as an adjacent prediction unit, and there is the prediction mode candidate index, a prediction mode indicated by the prediction mode candidate index is determined as the intra prediction mode of the current prediction unit.

[0128] If the received prediction flag indicates that the current prediction unit has the same intra prediction mode as an adjacent prediction unit, but there is no prediction mode candidate index and one available intra prediction mode of the adjacent prediction unit, the available intra prediction mode is restored to the intra prediction mode of the current prediction unit.

[0129] If the received prediction flag indicates that the current prediction unit does not have the same intra prediction mode as an adjacent prediction unit, a received residual intra prediction mode value is compared with intra prediction mode numbers of the available intra prediction mode candidates to restore the intra prediction mode of the current prediction unit.

[0130] The reference pixel generating unit 252 generates reference pixels using the same method as described in the reference pixel generating unit 151 of the coding apparatus 100. However, the reference pixel generator 252 is different from the reference pixel generator 151 of the coding apparatus 100 in that it adaptively generates reference pixels according to the intra prediction mode restored by the prediction mode decoder 251. That is, the reference pixel generating unit 252 may generate reference pixels only when the reference pixels used for generating a prediction block and determined by the intra prediction mode are not available.

[0131] The reference pixel filtering unit 253 adaptively filters the reference pixels based on the intra prediction mode restored by the prediction decoding unit 251 and a size of the prediction block. The filtering condition and a filter are same as those of the reference pixel filtering unit 152 of the coding apparatus 100.

[0132] The prediction block generating unit 254 generates a prediction block using the reference pixels according to the intra prediction mode restored by the prediction mode decoding unit 251.

[0133] The prediction block filtering unit 255 adaptively filters the prediction block according to the intra prediction mode restored by the prediction mode decoding unit 251. The filtering operation is the same as that of the prediction block filtering unit 154 of the coding apparatus 100.

[0134] The prediction block transmitting unit 256 transmits the prediction block received from the prediction block generator 254 or the prediction block filtering unit 255 to the adder 290.

## Claims

1. A prediction block generating device of a moving picture decoding apparatus, comprising:

a prediction mode decoding unit configured to determine an intra prediction mode of a current prediction unit using additional information included in a received additional information container and intended to generate a prediction block, and available intra prediction mode can-



didate information of the current prediction unit;  
 a reference pixel generating unit configured to  
 generate reference pixels at unavailable posi-  
 tions using available reference pixels so as to  
 generate an intra prediction block;

a reference pixel filtering unit configured to  
 adaptively filter reference pixels adjacent to the  
 current prediction unit on the basis of the deter-  
 mined intra prediction mode of the current pre-  
 diction unit or size information on the current pre-  
 diction unit; and

a prediction block generating unit configured to  
 generate a prediction block of the current pre-  
 diction unit using reference pixels correspond-  
 ing to the determined intra prediction mode of  
 the current prediction unit.

2. The prediction block generating device of claim 1,  
 further comprising:

a prediction block filtering unit configured to filter  
 some pixels in the prediction block generated  
 by the prediction block generating unit on the  
 basis of the determined intra prediction mode of  
 the current prediction unit,  
 wherein positions of the some pixels are deter-  
 mined according to the intra prediction mode.

3. The prediction block generating device of claim 1,  
 wherein, when available pixels are present in only  
 one direction, the reference pixel generating unit  
 generates the reference pixels at the unavailable po-  
 sitions using the closest available pixel.

4. The prediction block generating device of claim 1,  
 wherein the reference pixel filtering unit adaptively  
 performs filtering according to the size of the current  
 prediction unit.

5. The prediction block generating device of claim 1,  
 wherein the reference pixel filtering unit filters the  
 reference pixels using a filter of which value is [1, 2,  
 1].

6. The prediction block generating device of claim 1,  
 wherein the reference pixel filtering unit does not per-  
 form filtering on a prediction unit having a predeter-  
 mined size or less.

7. The prediction block generating device of claim 1,  
 wherein, when an intra prediction mode in which one  
 reference pixel is used to generate each pixel in the  
 prediction block is applied, the reference pixel filter-  
 ing unit does not filter the reference pixels.

8. The prediction block generating device of claim 1,  
 wherein the reference pixel filtering unit does not fil-  
 ter the reference pixels in a planar mode.

9. The prediction block generating device of claim 2,  
 wherein the prediction block filtering unit generates  
 the prediction block using the reference pixels on  
 any one of a left side and an upper side, and filters  
 some pixels in the prediction block generated ac-  
 cording to an intra prediction mode having a direc-  
 tion of 45° with reference to a horizontal direction or a  
 vertical direction.

10. The prediction block generating device of claim 1,  
 wherein the prediction block filtering unit filters re-  
 ference pixels in an intra prediction mode having a  
 direction of 45° with reference to a horizontal direc-  
 tion or a vertical direction.

FIG. 1

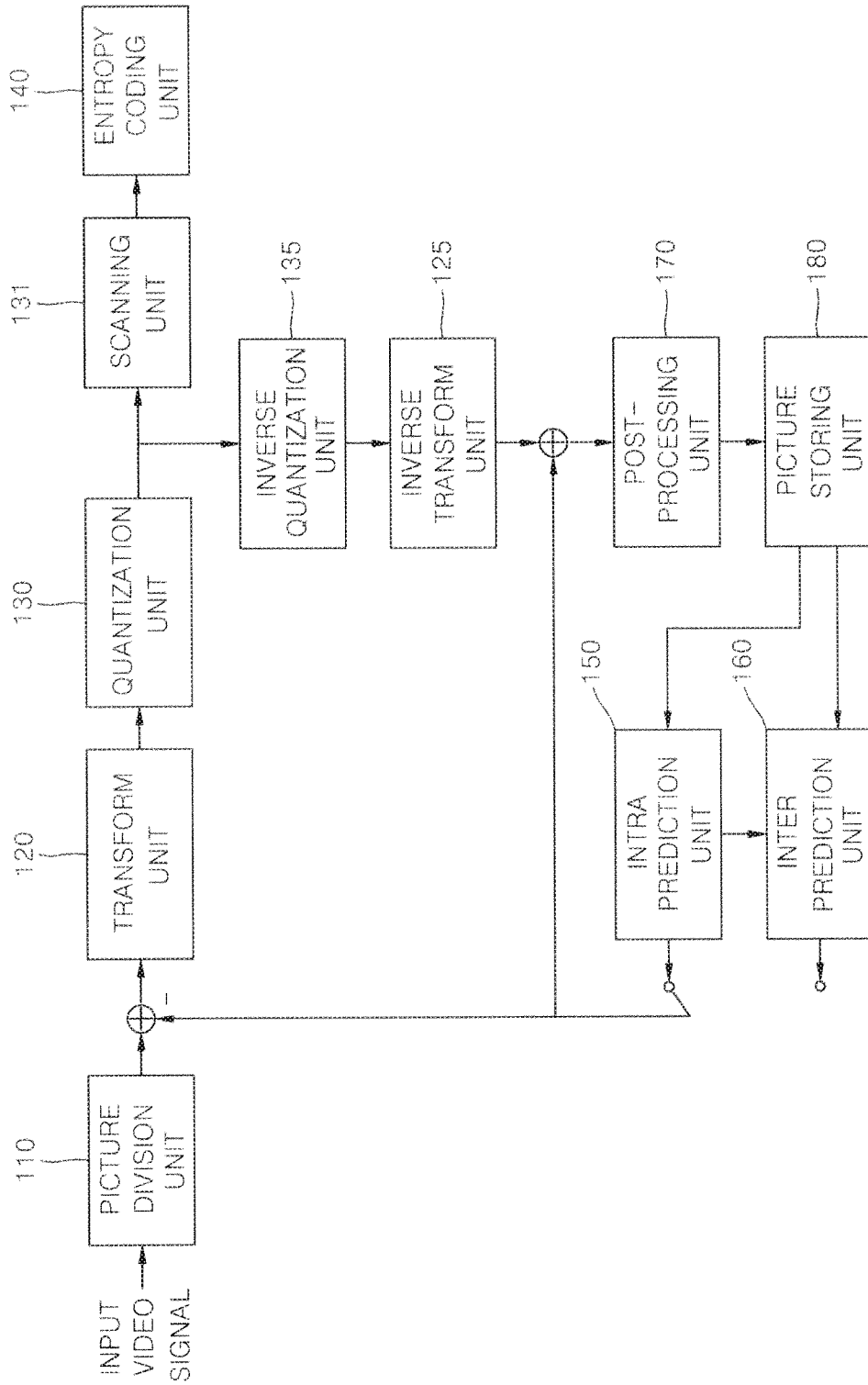

FIG. 2

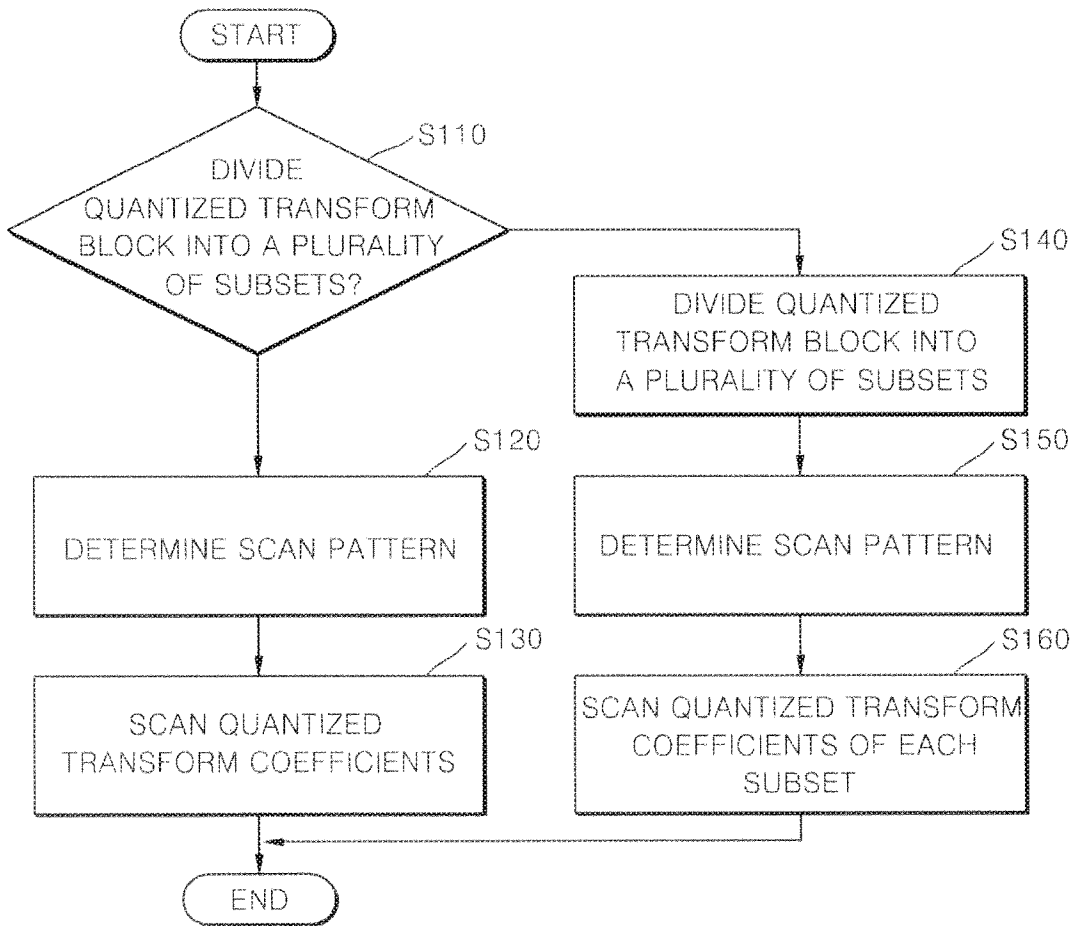

FIG. 3

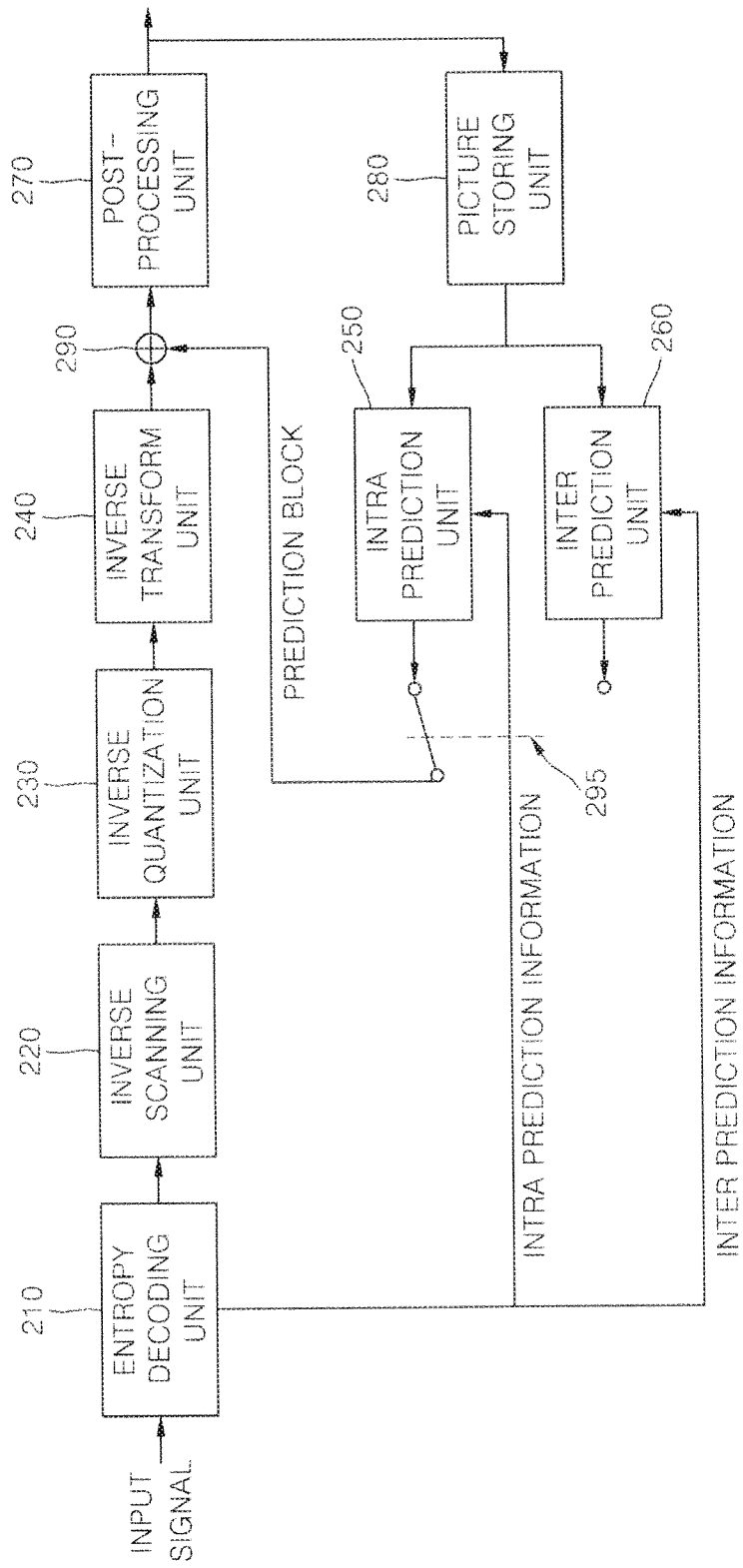

FIG. 4

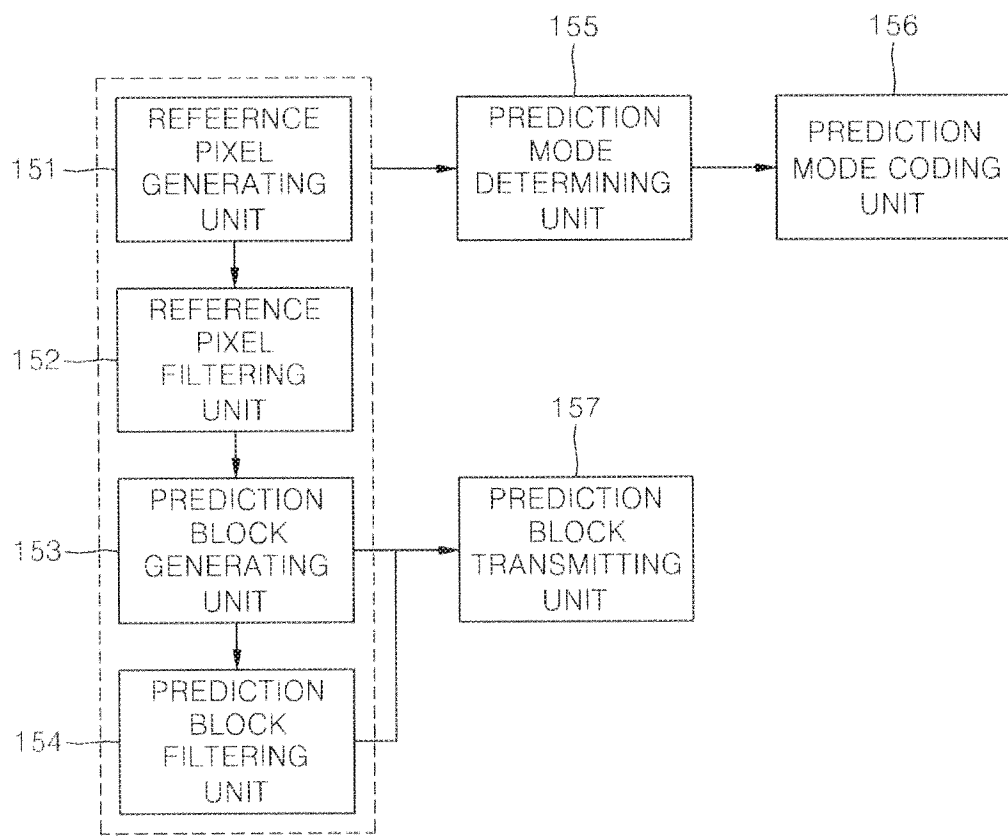

FIG. 5

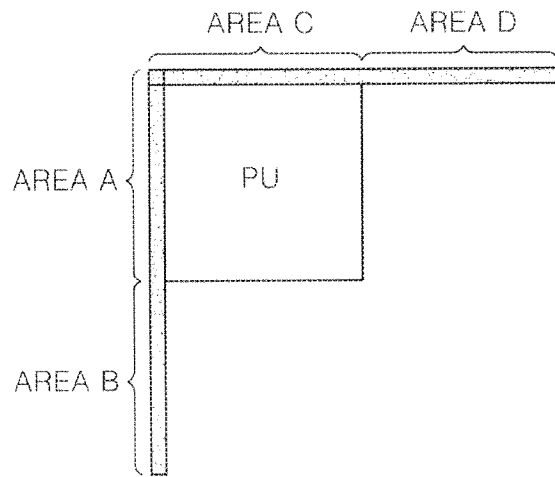

FIG. 6

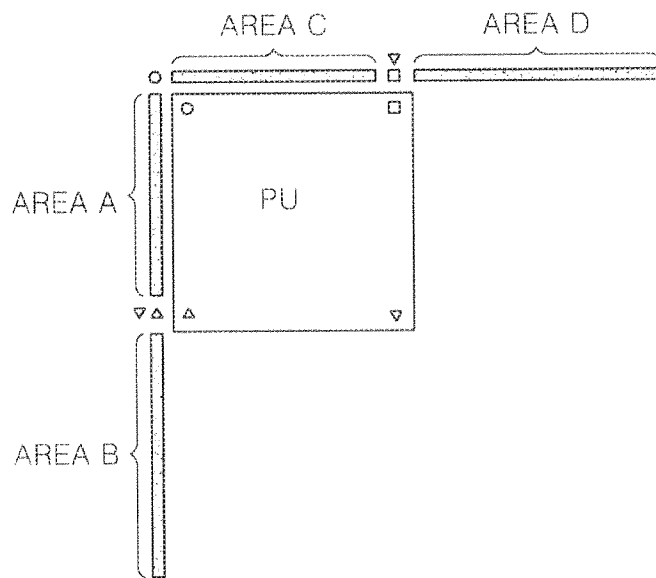
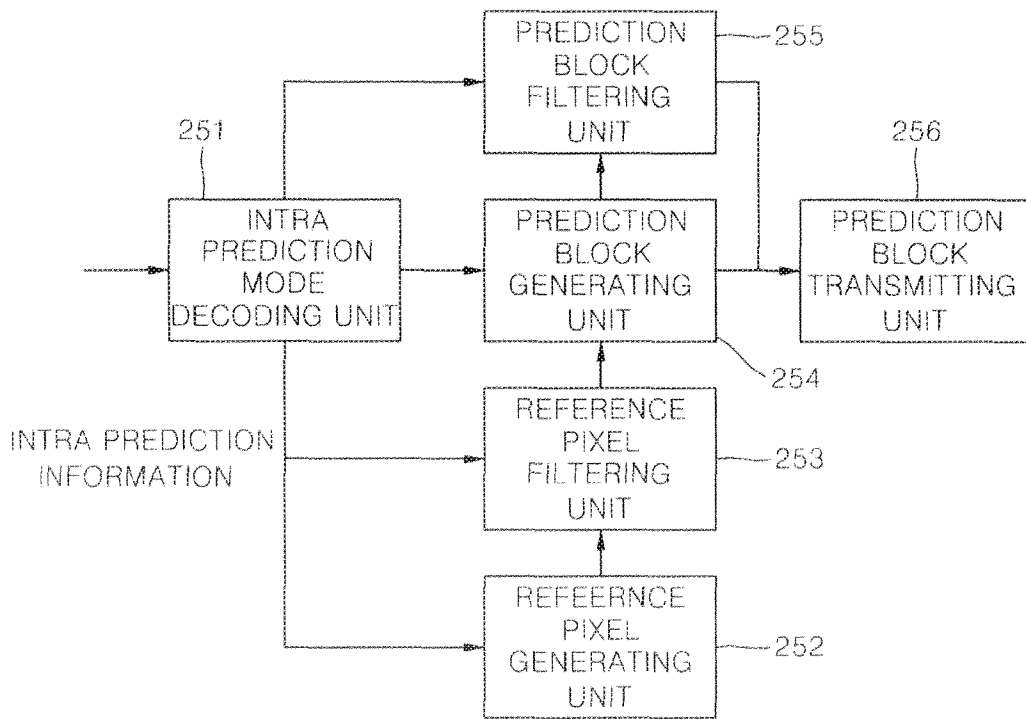

FIG. 7





Espacenet

Bibliographic data: JP2005512419 (A) — 2005-04-28

METHOD FOR CONDUCTING A DIRECTED PREDICTION OF AN IMAGE BLOCK

Inventor(s):

Applicant(s):

Classification: - international: H03M7/36; H04N19/11; H04N19/117; H04N19/593; H04N19/61; H04N19/82; H04N19/86;  
 (IPC1-7): H03M7/36; H04N7/32  
 - cooperative: H04N19/11; H04N19/117; H04N19/593; H04N19/61; H04N19/82; H04N19/86

Application number: JP20030550511 20020912

Priority number (s): DE2001158658 20011130 ; WO2002DE03390 20020912

Also published as: JP4268875 (B2) WO03049452 (A2) WO03049452 (A3) US2004136458 (A1) US7379499 (B2) more

Abstract not available for JP2005512419 (A)  
 Abstract of corresponding document: WO03049452 (A2)

Edge picture elements (A, B, C, D; E, F, G, H; I) of already predicted neighboring image blocks (A', B') are used in order to conduct a directed prediction of an image block (C'). According to the direction of prediction, the picture elements used for the prediction are pre-filtered along a block edge of the image block (C') to be currently predicted in order to suppress prediction artifacts.

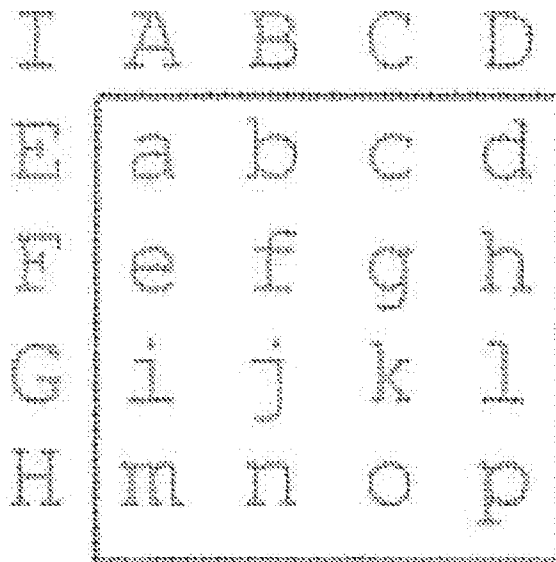



(19) 日本国特許庁 (JP)

(12) 公表特許公報 (A)

(11) 特許出願公表番号

特表2005-512419

(P2005-512419A)

(43) 公表日 平成17年4月28日 (2005.4.28)

(51) Int. Cl. <sup>7</sup>	F 1	テーマコード (参考)
HO4N 7/32	HO4N 7/137	5C059
HO3M 7/36	HO3M 7/36	5J064

審査請求 未請求 予備審査請求 未請求 (全 14 頁)

(21) 出願番号	特願2003-550511 (P2003-550511)	(71) 出願人	390023711
(86) (22) 出願日	平成14年9月12日 (2002.9.12)		ローベルト ボッシュ ゲゼルシャフト
(85) 翻訳文提出日	平成16年5月28日 (2004.5.28)		ミット ベシュレンクテル ハフツング
(86) 国際出願番号	PCT/DE2002/003390		ROBERT BOSCH GMBH
(87) 国際公開番号	W02003/049452		ドイツ連邦共和国 シュツツガルト (
(87) 国際公開日	平成15年6月12日 (2003.6.12)		番地なし)
(31) 優先権主張番号	101 58 658.2		Stuttgart, Germany
(32) 優先日	平成13年11月30日 (2001.11.30)	(74) 代理人	100061815
(33) 優先権主張国	ドイツ (DE)		弁理士 矢野 敏雄
(81) 指定国	EP (AT, BE, BG, CH, CY, CZ, DE, DK, EE, ES, FI, FR, GB, GR, IE, IT, LU, MC, NL, PT, SE, SK, TR), CN, JP, KR, US	(74) 代理人	100114890
			弁理士 アインゼル・フェリックス＝ラインハルト
		(74) 代理人	230100044
			弁護士 ラインハルト・アインゼル

最終頁に続く

(54) 【発明の名称】 画像ブロックの指向性予測方法

(57) 【要約】

画像ブロック (C') の指向性の予測のため、すでに予測された隣接画像ブロック (A', B') の周縁画素 (A, B, C, D; E, F, G, H; I) を利用する。予測アーチファクトを抑制する目的で、予測に利用される画素を予測方向に依存して現在予測すべき画像ブロック (C') のブロック周縁部に沿って予備フィルタリングする。

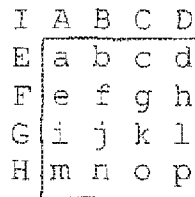

## 【特許請求の範囲】

## 【請求項1】

画像ブロック（C'）の画素（a, b, . . . , p）の指向性予測方法たとえば4×4よりも多くの画素から成るサイズをもつ画像ブロックのイントラ予測のための指向性予測方法において、

すでに予測された少なくとも1つの隣接画像ブロック（A', B'）の周囲画素（A, B, C, D; E, F, G, H）を現在の画像ブロック（C'）の予測に利用し、

予測方向に依存して予測に利用される画素を、予測すべき現在の画像ブロック（C'）のブロック周縁部に沿って予備フィルタリングすることを特徴とする、

指向性予測方法。

10

## 【請求項2】

少なくとも1つの隣接画像ブロックにおいて現在の画像ブロックの予測に利用される画素を1つの予測ベクトルにまとめ、該予測ベクトルの方向に沿って予測に利用される画素のローパスフィルタリングを行う、請求項1記載の方法。

## 【請求項3】

ローパスフィルタリングにおいてゼロポジションを最も強く重み付ける、請求項2記載の方法。

## 【請求項4】

ローパスフィルタリングのために現在の画像ブロックのブロック周縁領域を越えている画素も利用する、請求項1から3のいずれか1項記載の方法。

20

## 【請求項5】

予測のためブロック周縁領域を越えている画素を、前記予測ベクトルをブロック周縁部において延長することによって取得する、請求項4記載の方法。

## 【請求項6】

前記予測ベクトルの延長のため、該予測ベクトルの始端または終端におけるベクトル成分値を用いる、請求項5記載の方法。

## 【請求項7】

前記予測ベクトルの延長のため、隣接画像ブロックにおいて現在予測すべき画像ブロックと共通のブロック周縁部をもたない予測済みの画素を利用する、請求項5記載の方法。

## 【発明の詳細な説明】

30

## 【技術分野】

## 【0001】

従来の技術

本発明は複数の画素から成る画像ブロックの指向性予測方法に関し、たとえば4×4の画素よりも多くの画素数をもつ画像ブロックのイントラ予測のための方法に関する。

## 【0002】

文献[1] [http://standard.pictel.com/ftp/video-site/0109\\_San/](http://standard.pictel.com/ftp/video-site/0109_San/) のたとえば9頁～11頁から、ビデオ符号化標準H. 26Lのために4×4ピクセル（画素）ブロックまたは16×16ピクセルブロックにおけるイントラ予測を実施することが知られている。イントラ予測とは、現在の画像における伝送された情報だけが予測信号生成に利用されることを意味する（たとえばビデオシーケンスの第1の画像が常に「イントラ」符号化される）。4×4の予測のために文献[1]の場合には6個のモードを利用することができ、これらのモードは予測の行われる方向の点で異なっている。この場合、すでに予測された（符号化された）周辺画像ブロックの周辺画素が予測に利用される。

40

## 【0003】

請求項1の構成によれば、現在の画像ブロックの予測のためにやはりすでに予測された少なくとも1つの隣接画像ブロックの周辺画素が利用される。しかしこれに加えて、現在予測すべき画像ブロックのブロック周辺部に沿った予測方向に依存して、予測に利用される各画素がまえもってフィルタリングされる。このような予備フィルタリングによって予測特性が改善されることになり、殊に周辺長の大きいブロックすなわち4つの画素よりも

50

大きい周辺長をもつブロックについて改善されるようになる。

【0004】

本発明の基礎とする認識は、 $4 \times 4$ の画素よりも大きいブロックサイズたとえば $4 \times 8$ 、 $8 \times 4$ 、 $8 \times 8$ 、 $16 \times 8 \sim 16 \times 16$ のブロックサイズに対して指向性の予測を用いると、予測される画像ブロックに非常に目立つ構造が発生し、それによって再構成された画像において過度に強いアーチファクトが引き起こされることである。本発明による予備フィルタリングによれば予測信号が平滑化されてこのようなアーチファクトが回避され、そのことでこの種の予測画像ブロックを伝送するための符号化プロセスが主観的かつ客観的に改善されることになる。

【0005】

請求項2に記載の構成により、予測に利用される隣接画像ブロックの画素が1つの予測ベクトルにまとめられ、この予測ベクトルの方向に沿ってローパスフィルタリングが行われることになる。この構成によって、個別にフィルタリングする場合よりも処理の手間が簡単になる。

【0006】

請求項3に記載されているように、ゼロポジションすなわち現在予測すべき画素のポジションにおいてローパスフィルタリングを最も強く重み付けることにより予測ベクトルの経過特性が維持され続けるが、フィルタリングによってベクトルの平滑化が行われることになる。隣接する予測値が現在のポジションに及ぼす影響は、その予測値が現在ポジションから隔たっていればいるほど僅かになる。このことによって、ブロックサイズが大きくなるときに殊に効果的にアーチファクトが減衰する。

【0007】

請求項4に記載の構成もアーチファクト抑圧に有利にはたらく。

【0008】

請求項5～7にはブロック周辺部処理の有利な構成が示されている。殊に予測ベクトルをその周辺値によって続けることによって処理や記憶の手間が簡単になり、その結果、符号化効率が高まる。

【0009】

図面

次に、図面を参照しながら本発明の実施例について説明する。

【0010】

図1には、予測すべき画像ブロックがその隣接ブロックとともに示されている。

【0011】

図2には、現在予測すべき画像ブロックがその個別画素およびエッジにおける隣接ブロックの画素とともに示されている。

【0012】

図3には、種々の予測モードにおける予測方向が示されている。

【0013】

図4には、 $4 \times 4$ 画素のサイズをもつ画像ブロックがすでに予測された隣接ブロックの画素を利用して予測された画素とともに示されている。

【0014】

図5には、フィルタリングされていない予測による $8 \times 8$ 画素のサイズの画像ブロックが示されている。

【0015】

図6には、図5と同じ画像ブロックであるが本発明に従って予備フィルタリングされた画像ブロックが示されている。

【0016】

実施例の説明

本来の説明に立ち入る前に、理解を深める目的で文献[1]により知られている方向依存型のイントラ予測について詳しく説明する。文献[1]によるイントラ予測は、 $4 \times 4$

10

20

30

40

50

画素ブロックまたは $16 \times 16$ 画素ブロックにおいて実行される。 $4 \times 4$ 予測に対して6つのモードを用いることができ、それらのモードは予測の行われる方向の点で異なっている。この場合、すでに符号化された隣接画像ブロックの周辺画素（周辺ピクセル）が予測に利用される。図1には、現在予測すべき画像ブロックC'に対し考えられる隣接ブロックA'およびB'が描かれている。図2には現在の画像ブロックC'が自身の画素a, b, c~pおよび隣接画像ブロックの周辺画素とともに示されており、詳しくは上方で接する画像ブロックA'の画素A, B, C, Dと、左側で接する隣接画像ブロックB'の画素E, F, G, Hと、左上部のコーナーで接する隣接画像ブロック（図1では破線で示す）の画素Iとともに示されている。

【0017】

DC（直流成分）予測においては、画像ブロックC'のすべての画素に対する平均値としてポジションA~Hの平均値が利用されるが、このようなDC予測のほかに、それぞれ異なる予測方向をもつ5つのモードを使用することができる。水平方向と垂直方向の予測のほかにも3つの予測方向が可能である。これらの予測方向は図3に示されている。図4にはモード1による予測の例が示されている。このモードの場合、画素A~Dだけが予測に用いられる。モード1の場合には以下のようにして予測が行われる：

【0018】

【表1】

予測する画素	やり方
a	$(A+B)/2$
e	B
b, i	$(B+C)/2$
f, m	C
c, j	$(C+D)/2$
d, g, h, k, l, n, o, p	D

【0019】

$16 \times 16$ 画素ブロックをベースとする予測はアクティビティの僅かな画像領域において用いられる。この場合、DC予測、水平方向および垂直方向の予測、ならびにいくらか煩雑になる「平面的な」予測を用いることができる。イントラ予測法の完全な説明についてはH.26L-Test-Modell (TML) [1]を参照されたい。

【0020】

$4 \times 4$ 予測のために示された方法を他のブロックサイズにそのまま拡張することができる。このために予測が相応に続けられる。

【0021】

$4 \times 4$ 画像ブロックのために先に定義した形式の指向性予測を、 $4 \times 4$ 画素よりも大きい画像ブロックたとえば $4 \times 8$ ,  $8 \times 4$ ,  $8 \times 8$ ,  $16 \times 8$ , . . . ,  $16 \times 16$ の画素をもつ画像ブロックのために使用すべき場合、予測された画像ブロックにおいて著しく目立つ構造の発生する可能性があり、これにより再構成された画像において強いアーチファクトが引き起こされてしまう。本発明による措置によればこのようなアーチファクトが回避され、それによって符号化プロセスが主観的にも客観的にも改善される。

【0022】

ここでの説明は、TML [1]において $4 \times 4$ 画像ブロックのイントラ符号化に使用される指向性の予測モードを前提とする。この場合、 $4 \times 8$ ,  $8 \times 4$ ,  $8 \times 8$ ,  $8 \times 16$ ,  $16 \times 8$ ,  $16 \times 16$ というサイズの画像ブロックが考察される。 $4$ 画素よりも長いエッジにおいて、つまり $8$ 画素または $16$ 画素のエッジにおいてフィルタリングが行われる。この方法を他のブロックサイズならびに予測方向に使用することができる。

10

20

30

40

50

## 【0023】

以下ではM行およびN列のサイズをもつ現在の画像ブロックの画素を  $P(i, j)$ ,  $i = 0, \dots, N-1, j = 0, \dots, M-1$  として表す。予測に利用される隣接画像ブロックの画素はポジション  $P(-1, j)$  と  $P(i, -1)$  に位置する。これらは以下では長さ  $N_f$  の予測ベクトル  $V(n)$  にまとめられる。したがって先に示した  $4 \times 4$  ブロックに対するモード1の予測は  $N_f = 4$  である：  
 $V(n) = P(n, -1) = [A, B, C, D]$ ,  $n = 0, \dots, 3$

画像ブロックの予測のためには  $V(n)$  ではなく、フィルタリングされたバージョン  $V_f(n)$  が用いられる。フィルタリングのために、適切な長さLの(ローパス)フィルタが利用される。以下に例を示す：

10

## 【0024】

## 【表2】

エッジ長	フィルタ $h(n)$	フィルタ長L
8	$7/32, 18/32, 7/32$	3
16	$3/32, 7/32, 12/32, 7/32, 3/32$	5

## 【0025】

予備フィルタリングは予測方向に依存する。先に示したモード1では、現在予測すべき画像ブロックC'のブロック上縁に沿って行われる。予備フィルタリングは予測ベクトル  $V(n)$  の方向に沿って行われる。

20

## 【0026】

ローパスフィルタリングにより予測信号の平滑化が行われる。周縁部処理のために複数の可能性が存在する。すなわち、

— 右側および下方の周縁部に対して、ブロック周縁領域を越えている符号化済みの画素が利用され、たとえば  $V(n) = P(n, -1)$  ただし  $n = N, \dots, N_f - 1$  である。

— 左側および上方の周縁部に対して、エッジに沿って予測ベクトルが継続され、たとえば、

$V(n) = P(n, -1)$ 、この場合  $n = 0, \dots, N_f - 1$

30

$V(n) = P(-1, -(n+2))$ 、この場合  $n = -\text{int}(L/2), \dots, -1$  ただし  $\text{int}(x)$  は "rounding by truncation" (切り捨てによる丸め込み) を意味する。

## 【0027】

図5には、予備フィルタリングの作用がモード1による予測において  $8 \times 8$  画像ブロックについて例示されている。図5にはフィルタリングされていない予測が示されており、図6には、8画素のエッジ長に対して先に挙げた長さ3のフィルタによる予備フィルタリングにおいて予測された画像ブロックが示されている。

## 【0028】

次に、想定可能な予備フィルタリングの実施について述べる。

40

## 【0029】

この場合、 $8 \times 8$  ブロックであり  $P(i, j)$ ,  $i, j = 0, \dots, 7$ , 予測ベクトルは  $V(n)$ ,  $n = 0, \dots, 7$  とする。

## 【0030】

ここではエッジ長8の画像ブロックに対し3タップフィルタによりフィルタリングが行われ、ここでフィルタ係数  $h(n) = (7 \ 18 \ 7) / 32$  である。

## 【0031】

周縁部において一定に継続される予備フィルタリングにより以下ようになる：

$$V_f(0) = (7 * V(0) + 18 * V(0) + 7 * V(1)) / 32$$

$$V_f(1) = (7 * V(0) + 18 * V(2) + 7 * V(3)) / 32$$

50

$$V_f(2) = (7 * V(1) + 18 * V(3) + 7 * V(4)) / 32$$

...

$$V_f(7) = (7 * V(6) + 18 * V(7) + 7 * V(7)) / 32$$

ついでベクトル  $V_f(n)$ ,  $n = 0, \dots, 7$  が現在の画像ブロック  $C'$  の予測に用いられる。

#### 【0032】

図5に示されているように粗い量子化の場合、本発明による方法を用いなければ予測による強いアーチファクトが見えてしまう。本発明による方法を用いると、その代わりに（ローパスフィルタによるフィルタリングにおいて）柔らかい経過が生じようになる。すべてのAC（交流成分）係数がゼロまで量子化されている画像ブロックの場合、予測モードおよび使用されているフィルタの情報があれば、隣接画像ブロックの周縁画素からダイレクトに画像ブロックを求めることができる。

10

#### 【0033】

文献

[1] G. Bjontegaard, Thomas Wiegand (eds.), 'H.26L Test Model Long-Term (TML) 8', Doc. VCEG-N10, ITU-T Q6/SG16 VCEG, 14. Meeting, Santa Barbara, CA, September 2001

#### 【図面の簡単な説明】

#### 【0034】

【図1】 予測すべき画像ブロックをその隣接ブロックとともに示す図である。

20

【図2】 現在予測すべき画像ブロックをその個別画素およびエッジにおける隣接ブロックの画素とともに示す図である。

【図3】 種々の予測モードにおける予測方向を示す図である。

【図4】  $4 \times 4$  画素のサイズをもつ画像ブロックをすでに予測された隣接ブロックの画素を利用して予測された画素とともに示す図である。

【図5】 フィルタリングされていない予測による  $8 \times 8$  画素のサイズの画像ブロックを示す図である。

【図6】 図5と同じ画像ブロックであるが本発明に従って予備フィルタリングされた画像ブロックを示す図である。

【図 1】

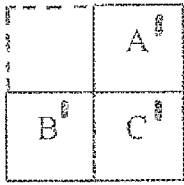

Fig. 1

【図 3】

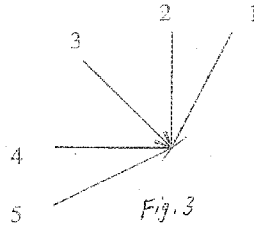

Fig. 3

【図 4】

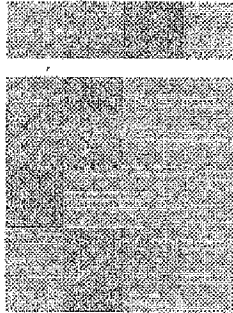

Fig. 4

【図 2】

I	A	B	C	D
E	a	b	c	d
F	e	f	g	h
G	i	j	k	l
H	m	n	o	p

Fig. 2

【図 5】

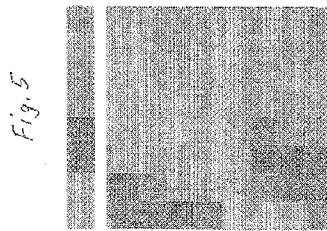

Fig. 5

【図 6】

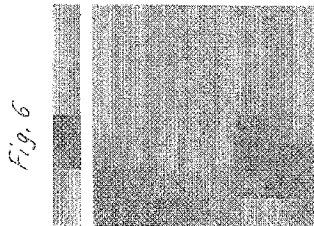

Fig. 6

## 【國際調查報告】

INTERNATIONAL SEARCH REPORT		Inventor's Application No. PCT/DE 02/03390
A. CLASSIFICATION OF SUBJECT MATTER IPC 7 HO4N7/34 HC4N7/26		
According to International Patent Classification (IPC) or to both national classification and IPC		
B. FIELDS SEARCHED		
Minimum documentation searched (classification system followed by classification symbols) IPC 7 HO4N		
Documentation searched other than minimum documentation to the extent that such documents are included in the fields searched		
Electronic data base consulted during the international search (name of data base and, where practical, search terms used) PAJ, EPO-Internal, WPI Data, INSPEC, COMPENDEX		
C. DOCUMENTS CONSIDERED TO BE RELEVANT		
Category *	Citation of document, with indication, where appropriate, of the relevant passages	Relevant to claim No.
A	G. BJONTEGAARD (ED): "H.26L TEST MODEL LONG TERM NUMBER 8 (TML-8) DRAFT " ITU-T TELECOMMUNICATION STANDARIZATION SECTOR OF ITU, 2 April 2001 (2001-04-02), pages 16-19, XPD02250455 GENEVA, CH cited in the application the whole document	1
A	PATENT ABSTRACTS OF JAPAN vol. 013, no. 468 (E-834), 23 October 1989 (1989-10-23) & JP 01 183276 A (FUJITSU LTD), 21 July 1989 (1989-07-21) abstract	1
<input checked="" type="checkbox"/> Further documents are listed in the continuation of box C. <input checked="" type="checkbox"/> Patent family members are listed in annex.		
* Special categories of cited documents : *A* document defining the general state of the art which is not considered to be of particular relevance *E* earlier document but published on or after the international filing date *L* document which may throw doubts on priority claim(s) or which is cited to establish the publication date of another citation or other special reason (as specified) *O* document referring to an oral disclosure, use, exhibition or other means *P* document published prior to the international filing date but after the priority date claimed *T* later document published after the international filing date or priority date and not in conflict with the application but cited to understand the principle or theory underlying the invention *X* document of particular relevance, the claimed invention cannot be considered novel or cannot be considered to involve an inventive step when the document is taken alone *Y* document of particular relevance, the claimed invention cannot be considered to involve an inventive step when the document is combined with one or more other such documents, such combination being obvious to a person skilled in the art. *Z* document member of the same patent family		
Date of the actual completion of the international search 7 August 2003		Date of making of the international search report 21/08/2003
Name and mailing address of the ISA European Patent Office, P.B. 5876 Patentstr 2 PL - 2280 HV Rijswijk Tel. (+31-70) 340-2040, Tx. 31 651 epo nl, Fax: (+31-70) 340-3016		Authorized officer Foglia, P

Form PCT/ISA/210 (second sheet) (July 1992)



## INTERNATIONAL SEARCH REPORT

 Int'l Application No  
 PCT/DE 02/03390

C.(Continuation) DOCUMENTS CONSIDERED TO BE RELEVANT		
Category	Citation of documents, with indication, where appropriate, of the relevant passages	Relevant to claim No.
A	WO 91 14340 A (THOMSON CONSUMER ELECTRONICS) 19 September 1991 (1991-09-19) page 10, paragraph 3 - paragraph 4; figure 1 -----	1
A	EP 1 146 748 A (SHARP KK) 17 October 2001 (2001-10-17) abstract -----	2
A	WO 98 41025 A (KALEVO OSSI ;NOKIA OYJ (FI); KARCZEWICZ MARTA (FI)) 17 September 1998 (1998-09-17) abstract page 2, line 22 - line 29 page 9, line 4 - line 8; figure 3 -----	1

Form PCT/ISA/210 (continuation of second sheet) (July 1992)

## INTERNATIONAL SEARCH REPORT

Information on patent family members

International Application No.  
PCT/DE 02/03390

Parent document cited in search report		Publication date	Patent family member(s)	Publication date
JP 01183276	A	21-07-1989	JP 2887168 B2	26-04-1999
WO 9114340	A	19-09-1991	AT 154485 T	15-06-1997
			AU 7480691 A	10-10-1991
			DE 69126525 D1	17-07-1997
			DE 69126525 T2	25-09-1997
			WO 9114340 A1	19-09-1991
			EP 0519995 A1	30-12-1992
			JP 2891773 B2	17-05-1999
			JP 5505080 T	29-07-1993
			KR 235815 B1	15-12-1999
EP 1146748	A	17-10-2001	EP 1146748 A2	17-10-2001
			JP 2001320586 A	16-11-2001
WO 9841025	A	17-09-1998	FI 971060 A	14-09-1998
			AU 6402298 A	29-09-1998
			DE 69806580 D1	22-08-2002
			DE 69806580 T2	13-02-2003
			EP 1198141 A2	17-04-2002
			EP 0966841 A1	29-12-1999
			WO 9841025 A1	17-09-1998
			JP 2002501691 T	15-01-2002

INTERNATIONAL SEARCH REPORT

INTERNATIONALER RECHERCHENBERICHT

Internes Anzeichen  
PCT/DE 02/03390

<b>A. KLASSIFIZIERUNG DES ANMELDUNGSGEGENSTANDES</b> IPK 7 H04N7/34 H04N7/26		
Nach der internationalen Patentklassifikation (IPK) oder nach der nationalen Klassifikation und der IPK		
<b>B. RECHERCHIERTE GEBIETE</b> Recherchierte Mindestprüfstoß (Klassifikationssystem und Klassifikationssymbole) IPK 7 H04N		
Recherchierte aber nicht zum Mindestprüfstoß gehörende Veröffentlichungen, soweit diese unter die recherchierten Gebiete fallen		
Während der internationalen Recherche konsultierte elektronische Datenbank (Name der Datenbank und evtl. verwendete Suchbegriffe) PAJ, EPO-Internal, WPI Data, INSPEC, COMPENDEX		
<b>C. ALS WESENTLICH ANGESEHENE UNTERLAGEN</b>		
Kategorie*	Bezeichnung der Veröffentlichung, soweit erforderlich unter Angabe der in Betracht kommenden Teile	Betr. Anspruch Nr.
A	G. BJONTEGAARD (ED): "H.26L TEST MODEL LONG TERM NUMBER 8 (TML-8) DRAFTO " ITU-T TELECOMMUNICATION STANDARIZATION SECTOR OF ITU, 2. April 2001 (2001-04-02), Seiten 16-19, XPO02250455 GENEVA, CH in der Anmeldung erwähnt das ganze Dokument	1
A	PATENT ABSTRACTS OF JAPAN vol. 013, no. 468 (E-834), 23. Oktober 1989 (1989-10-23) & JP 01 193276 A (FUJITSU LTD), 21. Juli 1989 (1989-07-21) Zusammenfassung	1
--- -/--		
<input checked="" type="checkbox"/> Weitere Veröffentlichungen sind der Fortsetzung von Feld C zu entnehmen		
<input checked="" type="checkbox"/> Siehe Anhang Patentfamilie		
* Besondere Kategorien von angegebenen Veröffentlichungen :		
<input type="checkbox"/> A* Veröffentlichung, die den allgemeinen Stand der Technik definiert, aber nicht als besonders bedeutsam anzusehen ist		
<input type="checkbox"/> E* älteres Dokument, das jedoch erst am oder nach dem internationalen Anmeldedatum veröffentlicht worden ist		
<input type="checkbox"/> I* Veröffentlichung, die geeignet ist, einen Prioritätsanspruch zweifelhaft erscheinen zu lassen, oder durch die das Veröffentlichungsdatum einer anderen im Recherchenbericht genannten Veröffentlichung belegt werden soll oder die aus einem anderen besonderen Grund angegeben ist (wie ausgesetzt)		
<input type="checkbox"/> O* Veröffentlichung, die sich auf eine mündliche Offenbarung, ohne Benutzung, ohne Ausübung oder andere Maßnahmen bezieht		
<input type="checkbox"/> P* Veröffentlichung, die vor dem internationalen Anmeldedatum, aber nach dem beanspruchten Prioritätsdatum veröffentlicht worden ist		
<input type="checkbox"/> S** Spätere Veröffentlichung, die nach dem internationalen Anmeldedatum oder dem Prioritätsdatum veröffentlicht worden ist, und mit der Anmeldung nicht kollidiert, sondern nur zum Verständnis des der Erfindung zugrundeliegenden Prinzips oder der ihr zugrundeliegenden Theorie angegeben ist		
<input type="checkbox"/> X* Veröffentlichung von besonderer Bedeutung, die beanspruchte Erfindung kann allein aufgrund dieser Veröffentlichung nicht als neu oder auf erfinderscher Tätigkeit beruhend betrachtet werden		
<input type="checkbox"/> Y* Veröffentlichung von besonderer Bedeutung, die beanspruchte Erfindung kann nicht als auf erfinderscher Tätigkeit beruhend betrachtet werden, wenn die Veröffentlichung mit einer oder mehreren anderen Veröffentlichungen dieser Kategorie in Verbindung gebracht wird und diese Verbindung für einen Fachmann selbständig ist		
<input type="checkbox"/> Z** Veröffentlichung, die Mitglied derselben Patentfamilie ist		
Datum des Abschlusses der internationalen Recherche		Absendedatum des internationalen Recherchenberichts
7. August 2003		21/08/2003
Name und Postanschrift der internationalen Recherchenbehörde Europäisches Patentamt, P.B. 5518 Patentleer 2 NL - 2250 HV Rijswijk Tel. (+31-70) 540-2540, Tx: 31 651 upc nl, Fac (+31-70) 540-3016		Bevollmächtigter Beauftragter Foglia, P

Formblatt P07/IS/R/10 (Sept. 9) (Juli 1992)

## INTERNATIONALER RECHERCHENBERICHT

 Nr.  
 des Aktenzeichens  
 PCT/DE 02/03390

C (Fortsetzung) ALS WESENTLICH ANGESEHENE UNTERLAGEN		
Kategorie	Bezeichnung der Veröffentlichung, soweit erforderlich unter Angabe der in Betracht kommenden Teile	Betr. Anspruch Nr.
A	WO 91 14340 A (THOMSON CONSUMER ELECTRONICS) 19. September 1991 (1991-09-19) Seite 10, Absatz 3 - Absatz 4; Abbildung 1	1
A	EP 1 146 748 A (SHARP KK) 17. Oktober 2001 (2001-10-17) Zusammenfassung	2
A	WO 98 41025 A (KALEVO OSSI ; NOKIA OYJ (FI); KARCZEWICZ MARTA (FI)) 17. September 1998 (1998-09-17) Zusammenfassung Seite 2, Zeile 22 - Zeile 29 Seite 9, Zeile 4 - Zeile 8; Abbildung 3	1

1

Formblatt PCT/SM/210 (Fortsetzung von Blatt 2) (Juli 1992)

## INTERNATIONALER RECHERCHENBERICHT

Angaben zu Veröffentlichungen, die zur selben Patentfamilie gehören

In  
plus A-Merkzeichen  
PCT/DE 02/03390

Im Recherchenbericht angeführtes Patentdokument		Datum der Veröffentlichung	Mitglied(er) der Patentfamilie	Datum der Veröffentlichung
JP 01183276	A	21-07-1989	JP 2887168 B2	26-04-1999
WO 9114340	A	19-09-1991	AT 154485 T	15-06-1997
			AU 7480691 A	10-10-1991
			DE 69126525 D1	17-07-1997
			DE 69126525 T2	25-09-1997
			WO 9114340 A1	19-09-1991
			EP 0519995 A1	30-12-1992
			JP 2891773 B2	17-05-1999
			JP 5505080 T	29-07-1993
			KR 235815 B1	15-12-1999
EP 1146748	A	17-10-2001	EP 1146748 A2	17-10-2001
			JP 2001320586 A	16-11-2001
WO 9841025	A	17-09-1998	FI 971060 A	14-09-1998
			AU 6402298 A	29-09-1998
			DE 69806580 D1	22-08-2002
			DE 69806580 T2	13-02-2003
			EP 1198141 A2	17-04-2002
			EP 0966841 A1	29-12-1999
			WO 9841025 A1	17-09-1998
			JP 2002501691 T	15-01-2002

Formblatt P0175A/E10 (Anhang Patentfamilie) (Juli 1992)

---

フロントページの続き

(72)発明者 アーヒム ダールホフ

ドイツ連邦共和国 アーヘン プレーメンベルク 24

(72)発明者 マティアス ヴィーン

ドイツ連邦共和国 アーヘン マウアーシュトラッセ 7

Fターム(参考) 5C059 KK03 MA04 PP25 UA02 UA12

5J064 AA00 BA04 BC11 BC21 BD02

## Electronic Acknowledgement Receipt

<b>EFS ID:</b>	26799773
<b>Application Number:</b>	14825825
<b>International Application Number:</b>	
<b>Confirmation Number:</b>	1431
<b>Title of Invention:</b>	METHOD AND APPARATUS FOR PERFORMING INTRA-PREDICTION USING ADAPTIVE FILTER
<b>First Named Inventor/Applicant Name:</b>	Jin Ho LEE
<b>Customer Number:</b>	96767
<b>Filer:</b>	Woochoon William Park/Lena Maxey
<b>Filer Authorized By:</b>	Woochoon William Park
<b>Attorney Docket Number:</b>	PA0929-2C
<b>Receipt Date:</b>	31-AUG-2016
<b>Filing Date:</b>	13-AUG-2015
<b>Time Stamp:</b>	14:05:51
<b>Application Type:</b>	Utility under 35 USC 111(a)

### Payment information:

Submitted with Payment	no
------------------------	----

### File Listing:

Document Number	Document Description	File Name	File Size(Bytes)/ Message Digest	Multi Part /.zip	Pages (if appl.)
1	Information Disclosure Statement (IDS) Form (SB08)	PA0929-2C_IDS_sb08a.pdf	613364  <small>74de1ef900f2c8e96ba3a3a09f64cf50328505a5</small>	no	5

### Warnings:

IPR2021-00827

<b>Information:</b>					
2	Foreign Reference	EP1845732A2.pdf	767713	no	26
			a8ed5bdb370106d5ef313aa6fd21c0da20708584		
<b>Warnings:</b>					
<b>Information:</b>					
3	Foreign Reference	WO2011021839A2.pdf	6130253	no	54
			c4d46dbfd6ddb07214e868a655cec3efaba2e7e8		
<b>Warnings:</b>					
<b>Information:</b>					
4	Foreign Reference	EP2600613A2.pdf	598071	no	18
			47b49ab86295cce231328ae9e0ad8a8fb6634f20		
<b>Warnings:</b>					
<b>Information:</b>					
5	Foreign Reference	EP2600614A2.pdf	505420	no	18
			1fb5756461eb0f19772f39b76f8b62b0ac4f3c78		
<b>Warnings:</b>					
<b>Information:</b>					
6	Foreign Reference	JP2005512419A.pdf	665857	no	15
			ea3cb93bc30d203ec8a915f39614cb3c5ff6e0a7		
<b>Warnings:</b>					
<b>Information:</b>					
7	Non Patent Literature	Variable_Block-Size_Transforms_for_H264-AVC.pdf	3303996	no	10
			277c7ce8a798ebca1b29c2e9a1ba36af2d4bfb43		
<b>Warnings:</b>					
<b>Information:</b>					
8	Non Patent Literature	Adaptive_In-Loop_Prediction_Refinement_for_Video_Coding.pdf	1149880	no	4
			25e0bccf931dc71c45c0b5ba8f17120c83d112b8		
<b>Warnings:</b>					
<b>Information:</b>					



9	Non Patent Literature	Description_of_video_coding_technology_proposal_by_ETRI.pdf	2581492	no	37
			4b4a02e44ac285acb72b17a380d586298b4c0daab		

**Warnings:**

**Information:**

10	Non Patent Literature	CE13_Mode_Dependent_Hybrid_Intra_Smoothing.pdf	223205	no	5
			1977bd55b7f4f84f033251aa8a804aeff16ab7de		

**Warnings:**

**Information:**

11	Non Patent Literature	An_Interpolation_Method_by_Predicting_the_Direction_of_Pixel_Texture_Changing.pdf	699561	no	5
			0a7e2c8b93f5f12c3ec137df3f2905a1bb85a782		

**Warnings:**

**Information:**

<b>Total Files Size (in bytes):</b>			17238812		
-------------------------------------	--	--	----------	--	--

**This Acknowledgement Receipt evidences receipt on the noted date by the USPTO of the indicated documents, characterized by the applicant, and including page counts, where applicable. It serves as evidence of receipt similar to a Post Card, as described in MPEP 503.**

**New Applications Under 35 U.S.C. 111**

**If a new application is being filed and the application includes the necessary components for a filing date (see 37 CFR 1.53(b)-(d) and MPEP 506), a Filing Receipt (37 CFR 1.54) will be issued in due course and the date shown on this Acknowledgement Receipt will establish the filing date of the application.**

**National Stage of an International Application under 35 U.S.C. 371**

**If a timely submission to enter the national stage of an international application is compliant with the conditions of 35 U.S.C. 371 and other applicable requirements a Form PCT/DO/EO/903 indicating acceptance of the application as a national stage submission under 35 U.S.C. 371 will be issued in addition to the Filing Receipt, in due course.**

**New International Application Filed with the USPTO as a Receiving Office**

**If a new international application is being filed and the international application includes the necessary components for an international filing date (see PCT Article 11 and MPEP 1810), a Notification of the International Application Number and of the International Filing Date (Form PCT/RO/105) will be issued in due course, subject to prescriptions concerning national security, and the date shown on this Acknowledgement Receipt will establish the international filing date of the application.**

**IN THE UNITED STATES PATENT AND TRADEMARK OFFICE**

Assignee: ELECTRONICS AND TELECOMMUNICATIONS RESEARCH INSTITUTE	
Inventor(s): Jin Ho LEE et al.	Group Art Unit: 2482
U.S. Serial No.: 14/825,825	Examiner: to be assigned
Filing Date: August 13, 2015	
Title: METHOD AND APPARATUS FOR PERFORMING INTRA-PREDICTION USING ADAPTIVE FILTER	

**TRANSMITTAL OF A PETITION UNDER 37 CFR 1.78(e)****Office of Petitions**

The Commissioner for Patents  
P.O. Box 1450  
Alexandria VA 22313-1450

Dear Sir or Madam:

The present U.S. Patent Application No. 14/825,825 filed on August 13, 2015 requires claims for the benefit of a prior-filed international application PCT/KR2011/002514 filed on April 11, 2011. Therefore, the applicant hereby petitions to claim the benefit of a prior-filed international application by submitting the following:

1. Reference required by 35 U.S.C. 120 and 37 CFR 1.78(d)(2) included in the corrected Application Data Sheet;
2. The fee under 37 CFR 1.17(m) (\$850.00 for small entity); and
3. A statement that the entire delay between the date the benefit claim was due under 37 CFR 1.78(d)(3) and the date the benefit claim was filed was unintentional.

The USPTO is encouraged to contact the undersigned by telephone to discuss any issues remaining.

Respectfully submitted,

Dated: April 6, 2016

Electronic signature: /W. William Park/  
W. William Park, Reg. No. 55,523  
William Park & Associates Ltd.  
930 N. York Road, Suite 201  
Hinsdale IL 60521

630-908-7652

**IN THE UNITED STATES PATENT AND TRADEMARK OFFICE**

Assignee: ELECTRONICS AND TELECOMMUNICATIONS RESEARCH INSTITUTE	
Inventor(s): Jin Ho LEE et al.	Group Art Unit: 2482
U.S. Serial No.: 14/825,825	Examiner: to be assigned
Filing Date: August 13, 2015	
Title: METHOD AND APPARATUS FOR PERFORMING INTRA-PREDICTION USING ADAPTIVE FILTER	

**STATEMENT UNDER 37 C.F.R. 1.78(e)(3)****Office of Petitions**

The Commissioner for Patents  
P.O. Box 1450  
Alexandria VA 22313-1450

Sir or Madam:

With respect to the above-identified non-provisional application filed on August 13, 2015, the applicant respectfully submits that the entire delay between the date the benefit claim of the international application PCT/KR2011/002514 was due under 37 CFR 1.78(d)(3) and the date the benefit claim of said international application was filed was unintentional.

The applicant asserts the parent application of the above-identified application (13/640,014) provides sufficient information that the entire delay was indeed unintentional.

The USPTO is encouraged to contact the undersigned by telephone to discuss any issues remaining.

Respectfully submitted,

Dated: April 6, 2016

Electronic signature: /W. William Park/  
W. William Park, Reg. No. 55,523  
William Park & Associates Ltd.  
930 N. York Road, Suite 201  
Hinsdale IL 60521  
630-908-7652

## Electronic Patent Application Fee Transmittal

<b>Application Number:</b>	14825825			
<b>Filing Date:</b>	13-Aug-2015			
<b>Title of Invention:</b>	METHOD AND APPARATUS FOR PERFORMING INTRA-PREDICTION USING ADAPTIVE FILTER			
<b>First Named Inventor/Applicant Name:</b>				
<b>Filer:</b>	Woochoon William Park/Mariana Maxey			
<b>Attorney Docket Number:</b>	PA0929-2C			
Filed as Small Entity				
<b>Filing Fees for Utility under 35 USC 111(a)</b>				
<b>Description</b>	<b>Fee Code</b>	<b>Quantity</b>	<b>Amount</b>	<b>Sub-Total in USD(\$)</b>
<b>Basic Filing:</b>				
Pet. Delay Sub or Restore Priority-Claim	2454	1	850	850
<b>Pages:</b>				
<b>Claims:</b>				
<b>Miscellaneous-Filing:</b>				
<b>Petition:</b>				
<b>Patent-Appeals-and-Interference:</b>				
<b>Post-Allowance-and-Post-Issuance:</b>				

Description	Fee Code	Quantity	Amount	Sub-Total in USD(\$)
<b>Extension-of-Time:</b>				
<b>Miscellaneous:</b>				
<b>Total in USD (\$)</b>				<b>850</b>

## Electronic Acknowledgement Receipt

<b>EFS ID:</b>	25415949
<b>Application Number:</b>	14825825
<b>International Application Number:</b>	
<b>Confirmation Number:</b>	1431
<b>Title of Invention:</b>	METHOD AND APPARATUS FOR PERFORMING INTRA-PREDICTION USING ADAPTIVE FILTER
<b>First Named Inventor/Applicant Name:</b>	
<b>Customer Number:</b>	96767
<b>Filer:</b>	Woochoon William Park/Mariana Maxey
<b>Filer Authorized By:</b>	Woochoon William Park
<b>Attorney Docket Number:</b>	PA0929-2C
<b>Receipt Date:</b>	06-APR-2016
<b>Filing Date:</b>	13-AUG-2015
<b>Time Stamp:</b>	16:44:38
<b>Application Type:</b>	Utility under 35 USC 111(a)

### Payment information:

Submitted with Payment	yes
Payment Type	Credit Card
Payment was successfully received in RAM	\$850
RAM confirmation Number	3387
Deposit Account	506178
Authorized User	DAVID, JONATHAN

The Director of the USPTO is hereby authorized to charge indicated fees and credit any overpayment as follows:

Charge any Additional Fees required under 37 CFR 1.16 (National application filing, search, and examination fees)

Charge any Additional Fees required under 37 CFR 1.17 (Patent application and reexamination processing fees)

IPR-2021-00827

Charge any Additional Fees required under 37 CFR 1.19 (Document supply fees)  
 Charge any Additional Fees required under 37 CFR 1.20 (Post Issuance fees)  
 Charge any Additional Fees required under 37 CFR 1.21 (Miscellaneous fees and charges)

**File Listing:**

Document Number	Document Description	File Name	File Size(Bytes)/ Message Digest	Multi Part /.zip	Pages (if appl.)
1	Application Data Sheet to update/ correct info	CorrectedADS.pdf	77479	no	6
			f7b0a491559a7a3845c32279b551e8d1033b64b0		
<b>Warnings:</b>					
<b>Information:</b>					
2	Petition for review by the Office of Petitions	PA0929-2C_Petition_Transmittal.pdf	16969	no	2
			4f58ac1f6938866e4d296bb911eed52956aed64		
<b>Warnings:</b>					
<b>Information:</b>					
3	Transmittal Letter	PA0929-2C_Statement_.pdf	15496	no	1
			6222864a2ff8b31ea3c554505528d1971b34a88c		
<b>Warnings:</b>					
<b>Information:</b>					
4	Fee Worksheet (SB06)	fee-info.pdf	30635	no	2
			64ee9f73826b150ae7815dca4dd976154e952c86		
<b>Warnings:</b>					
<b>Information:</b>					
<b>Total Files Size (in bytes):</b>			140579		

**This Acknowledgement Receipt evidences receipt on the noted date by the USPTO of the indicated documents, characterized by the applicant, and including page counts, where applicable. It serves as evidence of receipt similar to a Post Card, as described in MPEP 503.**

**New Applications Under 35 U.S.C. 111**

**If a new application is being filed and the application includes the necessary components for a filing date (see 37 CFR 1.53(b)-(d) and MPEP 506), a Filing Receipt (37 CFR 1.54) will be issued in due course and the date shown on this Acknowledgement Receipt will establish the filing date of the application.**

**National Stage of an International Application under 35 U.S.C. 371**

**If a timely submission to enter the national stage of an international application is compliant with the conditions of 35 U.S.C. 371 and other applicable requirements a Form PCT/DO/EO/903 indicating acceptance of the application as a national stage submission under 35 U.S.C. 371 will be issued in addition to the Filing Receipt, in due course.**

**New International Application Filed with the USPTO as a Receiving Office**

**If a new international application is being filed and the international application includes the necessary components for an international filing date (see PCT Article 11 and MPEP 1810), a Notification of the International Application Number and of the International Filing Date (Form PCT/RO/105) will be issued in due course, subject to prescriptions concerning national security, and the date shown on this Acknowledgement Receipt will establish the international filing date of the application.**



**CORRECTED ADS FORM**

Application Number	14825825
Title of Invention	METHOD AND APPARATUS FOR PERFORMING INTRA-PREDICTION USING ADAPTIVE FILTER

**Inventor Information**

**\*\*If no data is shown, no data has been corrected\*\***

	Data of Record	Updated Data
Order Number		
Name		

**Residence Information**

Residency		
City		
Country of Residence		

**Mailing Address of Inventor**

Address 1		
Address 2		
City,State/Province, Postal Code		
Country		

### Application Information

	Data of Record	Updated Data
Title of Invention	METHOD AND APPARATUS FOR PERFORMING INTRA-PREDICTION USING ADAPTIVE FILTER	
Attorney Docket Number	PA0929-2C	
Entity Type	Small	

### Domestic Benefit/National Stage Information

**\*\*If no data is shown, no data has been corrected\*\***

This section allows for the applicant to either claim benefit under 35 U.S.C. 119(e), 120, 121,365(c), or 386(c) or indicate National Stage entry from a PCT application. Providing this information in the application data sheet constitutes the specific reference required by 35 U.S. C. 119(e) or 120, and 37 CFR 1.78(a).

	Data of Record	Updated Data
Prior Application Status	pending	
Application Number	14825825	
Continuity Type	CON	
Prior Application Number	13640014	
Filing Date (YYYY-MM-DD)	2012-10-08	
Patent Number		
Issue Date (YYYY-MM-DD)	0001-01-01	

	Data of Record	Updated Data
Prior Application Status		<u>pending</u>
Application Number		<u>13640014</u>
Continuity Type		<u>NST</u>
Prior Application Number		<u>PCT/KR2011/002514</u>
Filing Date (YYYY-MM-DD)		<u>2011-04-11</u>
Patent Number		
Issue Date (YYYY-MM-DD)		

## Foreign Priority Information

**\*\*If no data is shown, no data has been corrected\*\***

This section allows for the applicant to claim priority to a foreign application. Providing this information in the application data sheet constitutes the claim for priority as required by 35 U.S.C. 119(b) and 37 CFR 1.55. When priority is claimed to a foreign application that is eligible for retrieval under the priority document exchange program (PDX) the information will be used by the Office to automatically attempt retrieval pursuant to 37 CFR 1.55(i)(1) and (2). Under the PDX program, applicant bears the ultimate responsibility for ensuring that a copy of the foreign application is received by the Office from the participating foreign intellectual property office, or a certified copy of the foreign priority application is filed, within the time period specified in 37 CFR 1.55(g)(1).

	Data of Record	Updated Data
Application Number		<u>10-2011-0032766</u>
Country		<u>KR</u>
Filing Date		<u>2011-04-08</u>
Access Code		
	Data of Record	Updated Data
Application Number		<u>10-2011-0026079</u>
Country		<u>KR</u>
Filing Date		<u>2011-03-23</u>
Access Code		

	Data of Record	Updated Data
Application Number		<u>10-2010-0032778</u>
Country		<u>KR</u>
Filing Date		<u>2010-04-09</u>
Access Code		

### Applicant Information

**\*\*If no data is shown, no data has been corrected\*\***

Providing assignment information in this section does not substitute for compliance with any requirement of part 3 of Title 37 of CFR to have an assignment recorded by the Office.

	Data of Record	Updated Data
Applicant Type		
If applicant is the legal representative, indicate the authority to file the patent application, the inventor is		
Name of the Deceased or Legally Incapacitated Inventor		
Applicant is an Organization		
Name		
Organization Name		
Address 1		
Address 2		
City,State/Province,Postal Code		
Country		
Phone Number		
Fax Number		

Email Address

## Assignee Information including Non-Applicant Assignee Information

**\*\*If no data is shown, no data has been corrected\*\***

Providing this information in the application data sheet does not substitute for compliance with any requirement of part 3 of Title 37 of the CFR to have an assignment recorded in the Office

	Data of Record	Updated Data
Order		
Applicant is an Organization		
Name		
Organization Name		

### Mailing Address

Address 1		
Address 2		
City,State/Province,Postal Code		
Country		
Phone Number		
Fax Number		
Email Address		

## Signature

NOTE: This Application Data Sheet must be signed in accordance with 37 CFR 1.33(b).

This Application Data Sheet **must** be signed by a patent practitioner if one or more of the applicants is a **juristic entity** (e.g., corporation or association). If the applicant is two or more joint inventors, this form must be signed by a patent practitioner, **all** joint inventors who are the applicant, or one or more joint inventor-applicants who have been given power of attorney (e.g., see USPTO Form PTO/AIA/81) on behalf of **all** joint inventor-applicants.

See 37 CFR 1.4(d) for the manner of making signatures and certifications.

Corrected ADS 1.0

Signature	/WOOCHOON PARK/	Registration Number	55523
First Name	WOOCHOON	Last Name	PARK



UNITED STATES PATENT AND TRADEMARK OFFICE

UNITED STATES DEPARTMENT OF COMMERCE
United States Patent and Trademark Office
Address: COMMISSIONER FOR PATENTS
P.O. Box 1450
Alexandria, Virginia 22313-1450
www.uspto.gov

Table with 4 columns: APPLICATION NUMBER (14/825,825), FILING OR 371(C) DATE (08/13/2015), FIRST NAMED APPLICANT (Jin Ho LEE), ATTY. DOCKET NO./TITLE (PA0929-2C)

CONFIRMATION NO. 1431

PUBLICATION NOTICE

96767
William Park & Associates LTD.
930 N. York Road, Suite 201
Hinsdale, IL 60521



Title:METHOD AND APPARATUS FOR PERFORMING INTRA-PREDICTION USING ADAPTIVE FILTER

Publication No.US-2016-0044337-A1
Publication Date:02/11/2016

NOTICE OF PUBLICATION OF APPLICATION

The above-identified application will be electronically published as a patent application publication pursuant to 37 CFR 1.211, et seq. The patent application publication number and publication date are set forth above.

The publication may be accessed through the USPTO's publically available Searchable Databases via the Internet at www.uspto.gov. The direct link to access the publication is currently http://www.uspto.gov/patft/.

The publication process established by the Office does not provide for mailing a copy of the publication to applicant. A copy of the publication may be obtained from the Office upon payment of the appropriate fee set forth in 37 CFR 1.19(a)(1). Orders for copies of patent application publications are handled by the USPTO's Office of Public Records. The Office of Public Records can be reached by telephone at (703) 308-9726 or (800) 972-6382, by facsimile at (703) 305-8759, by mail addressed to the United States Patent and Trademark Office, Office of Public Records, Alexandria, VA 22313-1450 or via the Internet.

In addition, information on the status of the application, including the mailing date of Office actions and the dates of receipt of correspondence filed in the Office, may also be accessed via the Internet through the Patent Electronic Business Center at www.uspto.gov using the public side of the Patent Application Information and Retrieval (PAIR) system. The direct link to access this status information is currently http://pair.uspto.gov/. Prior to publication, such status information is confidential and may only be obtained by applicant using the private side of PAIR.

Further assistance in electronically accessing the publication, or about PAIR, is available by calling the Patent Electronic Business Center at 1-866-217-9197.

Office of Data Management, Application Assistance Unit (571) 272-4000, or (571) 272-4200, or 1-888-786-0101



UNITED STATES PATENT AND TRADEMARK OFFICE

UNITED STATES DEPARTMENT OF COMMERCE  
United States Patent and Trademark Office  
Address: COMMISSIONER FOR PATENTS  
P.O. Box 1450  
Alexandria, Virginia 22313-1450  
www.uspto.gov

APPLICATION NUMBER	FILING OR 371(C) DATE	FIRST NAMED APPLICANT	ATTY. DOCKET NO./TITLE
14/825,825	08/13/2015	Jin Ho LEE	PA0929-2C

**CONFIRMATION NO. 1431**

**IMPROPER CFR REQUEST**

96767  
William Park & Associates LTD.  
930 N. York Road, Suite 201  
Hinsdale, IL 60521



Date Mailed: 01/20/2016

**RESPONSE TO REQUEST FOR CORRECTED FILING RECEIPT**

***Continuity, Priority Claims, Petitions, and Non-Publication Requests***

In response to your request for a corrected Filing Receipt, the Office is unable to comply with your request because:

- The priority or continuity claim has not been entered because it was not filed during the required time period. Applicant may wish to consider filing a petition to accept an unintentionally delayed claim for priority. See 37 CFR 1.55 or 1.78.

Questions about the contents of this notice and the requirements it sets forth should be directed to the Office of Data Management, Application Assistance Unit, at (571) 272-4000 or (571) 272-4200 or 1-888-786-0101.

/mmasfaw/



**IN THE UNITED STATES PATENT AND TRADEMARK OFFICE**

Inventor(s): Jin Ho LEE et al.	Group Art Unit: 2482
U.S. Serial No.: 14/825,825	Examiner: n/a
Filing Date: August 13, 2015	
Title: METHOD AND APPARATUS FOR PERFORMING INTRA-PREDICTION USING ADAPTIVE FILTER	

**CORRECTED APPLICATION DATA SHEET  
CLAIMING PRIORITY THROUGH REFERENCE**

The Commissioner for Patents  
P.O. Box 1450  
Alexandria VA 22313-1450

Dear Sir/Madam:

The present application is a continuation of US13/640,014 (filed on October 8, 2012), which is a 371 of The PCT application PCT/KR2011/002514 filed on April 11, 2011 which claims foreign priority to Korean applications KR10-2010-0032778, KR10-2011-0026079, and KR10-2011-0032766, filed April 09, 2010, March 23, 2011, and April 08, 2011 respectively.

The intermediate PCT application information was inadvertently omitted in the Application Data Sheet filed on August 13, 2015 for the present application. The missing PCT information resulted in a broken chain of benefit. As such, the three foreign priority applications were omitted from the Filing Receipt, though they were submitted in the ADS filed August 13, 2015.

Upon resubmission of the ADS during the pendency of the prior filed applications, and within 4 months from the filing of the present application, the applicant asserts that the three foreign priority applications are hereby claimed through continuity.

The following documents are submitted herewith:

- 1) A Web Based E-processing ADS showing correct benefit information and the additions underlined.

- 2) A supplemental Application Data Sheet to replace the previously filed Application Data Sheet.

Additionally, the applicant requests that a Corrected Filing Receipt be issued reflecting the changes indicated here and proven through reference.

The USPTO is encouraged to contact the undersigned by telephone to discuss any issues remaining.

Respectfully submitted,

Dated: January 13, 2016  
Electronic signature: /W. William Park/  
W. William Park, Reg. No. 55,523  
William Park & Associates Ltd.  
930 N. York Road, Suite 201  
Hinsdale IL 60521  
630-908-7652

**CORRECTED ADS FORM**

Application Number	14825825
Title of Invention	METHOD AND APPARATUS FOR PERFORMING INTRA-PREDICTION USING ADAPTIVE FILTER

**Inventor Information**

**\*\*If no data is shown, no data has been corrected\*\***

	Data of Record	Updated Data
Order Number		
Name		

**Residence Information**

Residency		
City		
Country of Residence		

**Mailing Address of Inventor**

Address 1		
Address 2		
City,State/Province, Postal Code		
Country		

### Application Information

	Data of Record	Updated Data
Title of Invention	METHOD AND APPARATUS FOR PERFORMING INTRA-PREDICTION USING ADAPTIVE FILTER	
Attorney Docket Number	PA0929-2C	
Entity Type	Small	

### Domestic Benefit/National Stage Information

**\*\*If no data is shown, no data has been corrected\*\***

This section allows for the applicant to either claim benefit under 35 U.S.C. 119(e), 120, 121,365(c), or 386(c) or indicate National Stage entry from a PCT application. Providing this information in the application data sheet constitutes the specific reference required by 35 U.S. C. 119(e) or 120, and 37 CFR 1.78(a).

	Data of Record	Updated Data
Prior Application Status	pending	
Application Number	14825825	
Continuity Type	CON	
Prior Application Number	13640014	
Filing Date (YYYY-MM-DD)	2012-10-08	
Patent Number		
Issue Date (YYYY-MM-DD)	0001-01-01	

	Data of Record	Updated Data
Prior Application Status		<u>pending</u>
Application Number		<u>13640014</u>
Continuity Type		<u>NST</u>
Prior Application Number		<u>PCT/KR2011/002514</u>
Filing Date (YYYY-MM-DD)		<u>2011-04-11</u>
Patent Number		
Issue Date (YYYY-MM-DD)		

## Foreign Priority Information

**\*\*If no data is shown, no data has been corrected\*\***

This section allows for the applicant to claim priority to a foreign application. Providing this information in the application data sheet constitutes the claim for priority as required by 35 U.S.C. 119(b) and 37 CFR 1.55. When priority is claimed to a foreign application that is eligible for retrieval under the priority document exchange program (PDX) the information will be used by the Office to automatically attempt retrieval pursuant to 37 CFR 1.55(i)(1) and (2). Under the PDX program, applicant bears the ultimate responsibility for ensuring that a copy of the foreign application is received by the Office from the participating foreign intellectual property office, or a certified copy of the foreign priority application is filed, within the time period specified in 37 CFR 1.55(g)(1).

	Data of Record	Updated Data
Application Number		<u>10-2010-0032778</u>
Country		<u>KR</u>
Filing Date		<u>2010-04-09</u>
Access Code		
	Data of Record	Updated Data
Application Number		<u>10-2011-0026079</u>
Country		<u>KR</u>
Filing Date		<u>2011-03-23</u>
Access Code		

	Data of Record	Updated Data
Application Number		<u>10-2011-0032766</u>
Country		<u>KR</u>
Filing Date		<u>2011-04-08</u>
Access Code		

### Applicant Information

**\*\*If no data is shown, no data has been corrected\*\***

Providing assignment information in this section does not substitute for compliance with any requirement of part 3 of Title 37 of CFR to have an assignment recorded by the Office.

	Data of Record	Updated Data
Applicant Type		
If applicant is the legal representative, indicate the authority to file the patent application, the inventor is		
Name of the Deceased or Legally Incapacitated Inventor		
Applicant is an Organization		
Name		
Organization Name		
Address 1		
Address 2		
City,State/Province,Postal Code		
Country		
Phone Number		
Fax Number		

Email Address

## Assignee Information including Non-Applicant Assignee Information

**\*\*If no data is shown, no data has been corrected\*\***

Providing this information in the application data sheet does not substitute for compliance with any requirement of part 3 of Title 37 of the CFR to have an assignment recorded in the Office

	Data of Record	Updated Data
Order		
Applicant is an Organization		
Name		
Organization Name		

### Mailing Address

Address 1		
Address 2		
City,State/Province,Postal Code		
Country		
Phone Number		
Fax Number		
Email Address		

## Signature

NOTE: This Application Data Sheet must be signed in accordance with 37 CFR 1.33(b).

This Application Data Sheet **must** be signed by a patent practitioner if one or more of the applicants is a **juristic entity** (e.g., corporation or association). If the applicant is two or more joint inventors, this form must be signed by a patent practitioner, **all** joint inventors who are the applicant, or one or more joint inventor-applicants who have been given power of attorney (e.g., see USPTO Form PTO/AIA/81) on behalf of **all** joint inventor-applicants.

See 37 CFR 1.4(d) for the manner of making signatures and certifications.

Corrected ADS 1.0

Signature	/WOOCHOON PARK/	Registration Number	55523
First Name	WOOCHOON	Last Name	PARK



## Electronic Acknowledgement Receipt

<b>EFS ID:</b>	24612911
<b>Application Number:</b>	14825825
<b>International Application Number:</b>	
<b>Confirmation Number:</b>	1431
<b>Title of Invention:</b>	METHOD AND APPARATUS FOR PERFORMING INTRA-PREDICTION USING ADAPTIVE FILTER
<b>First Named Inventor/Applicant Name:</b>	
<b>Customer Number:</b>	96767
<b>Filer:</b>	Woochoon William Park
<b>Filer Authorized By:</b>	
<b>Attorney Docket Number:</b>	PA0929-2C
<b>Receipt Date:</b>	13-JAN-2016
<b>Filing Date:</b>	13-AUG-2015
<b>Time Stamp:</b>	16:08:58
<b>Application Type:</b>	Utility under 35 USC 111(a)

### Payment information:

Submitted with Payment	no
------------------------	----

### File Listing:

Document Number	Document Description	File Name	File Size(Bytes)/ Message Digest	Multi Part /.zip	Pages (if appl.)
1	Request for Corrected Filing Receipt	PA0929-2C_Transmittal_Letter.pdf	16932 <small>48be7e8dfcdec83fe0066bc656a1a2d087ac5541</small>	no	2

### Warnings:

### Information:

IPR2021-00827

2	Application Data Sheet to update/ correct info	CorrectedADS.pdf	77487  ffe882b78332be386c6b50ab7f66cf471935 d089	no	6
---	---	------------------	---	----	---

**Warnings:**

**Information:**

<b>Total Files Size (in bytes):</b>	94419
-------------------------------------	-------

**This Acknowledgement Receipt evidences receipt on the noted date by the USPTO of the indicated documents, characterized by the applicant, and including page counts, where applicable. It serves as evidence of receipt similar to a Post Card, as described in MPEP 503.**

**New Applications Under 35 U.S.C. 111**

**If a new application is being filed and the application includes the necessary components for a filing date (see 37 CFR 1.53(b)-(d) and MPEP 506), a Filing Receipt (37 CFR 1.54) will be issued in due course and the date shown on this Acknowledgement Receipt will establish the filing date of the application.**

**National Stage of an International Application under 35 U.S.C. 371**

**If a timely submission to enter the national stage of an international application is compliant with the conditions of 35 U.S.C. 371 and other applicable requirements a Form PCT/DO/EO/903 indicating acceptance of the application as a national stage submission under 35 U.S.C. 371 will be issued in addition to the Filing Receipt, in due course.**

**New International Application Filed with the USPTO as a Receiving Office**

**If a new international application is being filed and the international application includes the necessary components for an international filing date (see PCT Article 11 and MPEP 1810), a Notification of the International Application Number and of the International Filing Date (Form PCT/RO/105) will be issued in due course, subject to prescriptions concerning national security, and the date shown on this Acknowledgement Receipt will establish the international filing date of the application.**



UNITED STATES PATENT AND TRADEMARK OFFICE

UNITED STATES DEPARTMENT OF COMMERCE
United States Patent and Trademark Office
Address: COMMISSIONER FOR PATENTS
P.O. Box 1450
Alexandria, Virginia 22313-1450
www.uspto.gov

Table with 7 columns: APPLICATION NUMBER, FILING or 371(c) DATE, GRP ART UNIT, FIL FEE REC'D, ATTY. DOCKET NO, TOT CLAIMS, IND CLAIMS. Row 1: 14/825,825, 08/13/2015, 2482, 730, PA0929-2C, 3, 1

CONFIRMATION NO. 1431

UPDATED FILING RECEIPT

96767
William Park & Associates LTD.
930 N. York Road, Suite 201
Hinsdale, IL 60521



Date Mailed: 11/02/2015

Receipt is acknowledged of this non-provisional patent application. The application will be taken up for examination in due course. Applicant will be notified as to the results of the examination. Any correspondence concerning the application must include the following identification information: the U.S. APPLICATION NUMBER, FILING DATE, NAME OF APPLICANT, and TITLE OF INVENTION. Fees transmitted by check or draft are subject to collection. Please verify the accuracy of the data presented on this receipt. If an error is noted on this Filing Receipt, please submit a written request for a Filing Receipt Correction. Please provide a copy of this Filing Receipt with the changes noted thereon. If you received a "Notice to File Missing Parts" for this application, please submit any corrections to this Filing Receipt with your reply to the Notice. When the USPTO processes the reply to the Notice, the USPTO will generate another Filing Receipt incorporating the requested corrections

Inventor(s)

Jin Ho LEE, Daejeon-si, KOREA, REPUBLIC OF;
Hui Yong KIM, Daejeon-si, KOREA, REPUBLIC OF;
Se Yoon JEONG, Daejeon-si, KOREA, REPUBLIC OF;
Suk Hee CHO, Daejeon-si, KOREA, REPUBLIC OF;
Ha Hyun LEE, Seoul, KOREA, REPUBLIC OF;
Jong Ho KIM, Daejeon-si, KOREA, REPUBLIC OF;
Sung Chang LIM, Daejeon-si, KOREA, REPUBLIC OF;
Jin Soo CHOI, Daejeon-si, KOREA, REPUBLIC OF;
Jin Woong KIM, Daejeon-si, KOREA, REPUBLIC OF;
Chie Teuk AHN, Daejeon-si, KOREA, REPUBLIC OF;

Applicant(s)

Electronics and Telecommunications Research Institute, Daejeon, KOREA, REPUBLIC OF;

Power of Attorney: The patent practitioners associated with Customer Number 96767

Domestic Priority data as claimed by applicant

This application is a CON of 13/640,014 10/08/2012

Foreign Applications for which priority is claimed (You may be eligible to benefit from the Patent Prosecution Highway program at the USPTO. Please see http://www.uspto.gov for more information.) - None.

Foreign application information must be provided in an Application Data Sheet in order to constitute a claim to foreign priority. See 37 CFR 1.55 and 1.76.

Permission to Access - A proper Authorization to Permit Access to Application by Participating Offices (PTO/SB/39 or its equivalent) has been received by the USPTO.

**If Required, Foreign Filing License Granted:** 08/27/2015

The country code and number of your priority application, to be used for filing abroad under the Paris Convention, is **US 14/825,825**

**Projected Publication Date:** 02/11/2016

**Non-Publication Request:** No

**Early Publication Request:** No

**\*\* SMALL ENTITY \*\***

**Title**

METHOD AND APPARATUS FOR PERFORMING INTRA-PREDICTION USING ADAPTIVE FILTER

**Preliminary Class**

375

**Statement under 37 CFR 1.55 or 1.78 for AIA (First Inventor to File) Transition Applications:** No

### **PROTECTING YOUR INVENTION OUTSIDE THE UNITED STATES**

Since the rights granted by a U.S. patent extend only throughout the territory of the United States and have no effect in a foreign country, an inventor who wishes patent protection in another country must apply for a patent in a specific country or in regional patent offices. Applicants may wish to consider the filing of an international application under the Patent Cooperation Treaty (PCT). An international (PCT) application generally has the same effect as a regular national patent application in each PCT-member country. The PCT process **simplifies** the filing of patent applications on the same invention in member countries, but **does not result** in a grant of "an international patent" and does not eliminate the need of applicants to file additional documents and fees in countries where patent protection is desired.

Almost every country has its own patent law, and a person desiring a patent in a particular country must make an application for patent in that country in accordance with its particular laws. Since the laws of many countries differ in various respects from the patent law of the United States, applicants are advised to seek guidance from specific foreign countries to ensure that patent rights are not lost prematurely.

Applicants also are advised that in the case of inventions made in the United States, the Director of the USPTO must issue a license before applicants can apply for a patent in a foreign country. The filing of a U.S. patent application serves as a request for a foreign filing license. The application's filing receipt contains further information and guidance as to the status of applicant's license for foreign filing.

Applicants may wish to consult the USPTO booklet, "General Information Concerning Patents" (specifically, the section entitled "Treaties and Foreign Patents") for more information on timeframes and deadlines for filing foreign patent applications. The guide is available either by contacting the USPTO Contact Center at 800-786-9199, or it can be viewed on the USPTO website at <http://www.uspto.gov/web/offices/pac/doc/general/index.html>.

For information on preventing theft of your intellectual property (patents, trademarks and copyrights), you may wish to consult the U.S. Government website, <http://www.stopfakes.gov>. Part of a Department of Commerce initiative, this website includes self-help "toolkits" giving innovators guidance on how to protect intellectual property in specific countries such as China, Korea and Mexico. For questions regarding patent enforcement issues, applicants may call the U.S. Government hotline at 1-866-999-HALT (1-866-999-4258).

**LICENSE FOR FOREIGN FILING UNDER**  
**Title 35, United States Code, Section 184**  
**Title 37, Code of Federal Regulations, 5.11 & 5.15**

**GRANTED**

The applicant has been granted a license under 35 U.S.C. 184, if the phrase "IF REQUIRED, FOREIGN FILING LICENSE GRANTED" followed by a date appears on this form. Such licenses are issued in all applications where the conditions for issuance of a license have been met, regardless of whether or not a license may be required as set forth in 37 CFR 5.15. The scope and limitations of this license are set forth in 37 CFR 5.15(a) unless an earlier license has been issued under 37 CFR 5.15(b). The license is subject to revocation upon written notification. The date indicated is the effective date of the license, unless an earlier license of similar scope has been granted under 37 CFR 5.13 or 5.14.

This license is to be retained by the licensee and may be used at any time on or after the effective date thereof unless it is revoked. This license is automatically transferred to any related applications(s) filed under 37 CFR 1.53(d). This license is not retroactive.

The grant of a license does not in any way lessen the responsibility of a licensee for the security of the subject matter as imposed by any Government contract or the provisions of existing laws relating to espionage and the national security or the export of technical data. Licensees should apprise themselves of current regulations especially with respect to certain countries, of other agencies, particularly the Office of Defense Trade Controls, Department of State (with respect to Arms, Munitions and Implements of War (22 CFR 121-128)); the Bureau of Industry and Security, Department of Commerce (15 CFR parts 730-774); the Office of Foreign Assets Control, Department of Treasury (31 CFR Parts 500+) and the Department of Energy.

**NOT GRANTED**

No license under 35 U.S.C. 184 has been granted at this time, if the phrase "IF REQUIRED, FOREIGN FILING LICENSE GRANTED" DOES NOT appear on this form. Applicant may still petition for a license under 37 CFR 5.12, if a license is desired before the expiration of 6 months from the filing date of the application. If 6 months has lapsed from the filing date of this application and the licensee has not received any indication of a secrecy order under 35 U.S.C. 181, the licensee may foreign file the application pursuant to 37 CFR 5.15(b).

---

***SelectUSA***

The United States represents the largest, most dynamic marketplace in the world and is an unparalleled location for business investment, innovation, and commercialization of new technologies. The U.S. offers tremendous resources and advantages for those who invest and manufacture goods here. Through SelectUSA, our nation works to promote and facilitate business investment. SelectUSA provides information assistance to the international investor community; serves as an ombudsman for existing and potential investors; advocates on behalf of U.S. cities, states, and regions competing for global investment; and counsels U.S. economic development organizations on investment attraction best practices. To learn more about why the United States is the best country in the world to develop technology, manufacture products, deliver services, and grow your business, visit <http://www.SelectUSA.gov> or call +1-202-482-6800.

**PATENT APPLICATION FEE DETERMINATION RECORD**

Substitute for Form PTO-875

Application or Docket Number  
14/825,825

**APPLICATION AS FILED - PART I**

(Column 1) (Column 2)

FOR	NUMBER FILED	NUMBER EXTRA
BASIC FEE (37 CFR 1.16(a), (b), or (c))	N/A	N/A
SEARCH FEE (37 CFR 1.16(k), (l), or (m))	N/A	N/A
EXAMINATION FEE (37 CFR 1.16(o), (p), or (q))	N/A	N/A
TOTAL CLAIMS (37 CFR 1.16(j))	3	minus 20 = *
INDEPENDENT CLAIMS (37 CFR 1.16(h))	1	minus 3 = *
APPLICATION SIZE FEE (37 CFR 1.16(s))	If the specification and drawings exceed 100 sheets of paper, the application size fee due is \$310 (\$155 for small entity) for each additional 50 sheets or fraction thereof. See 35 U.S.C. 41(a)(1)(G) and 37 CFR 1.16(s).	
MULTIPLE DEPENDENT CLAIM PRESENT (37 CFR 1.16(j))		

\* If the difference in column 1 is less than zero, enter "0" in column 2.

**SMALL ENTITY**

RATE(\$)	FEE(\$)
N/A	70
N/A	300
N/A	360
x 40 =	0.00
x 210 =	0.00
	0.00
	0.00
<b>TOTAL</b>	<b>730</b>

**OR OTHER THAN SMALL ENTITY**

RATE(\$)	FEE(\$)
N/A	
N/A	
N/A	
<b>TOTAL</b>	

**APPLICATION AS AMENDED - PART II**

(Column 1) (Column 2) (Column 3)

AMENDMENT A		CLAIMS REMAINING AFTER AMENDMENT		HIGHEST NUMBER PREVIOUSLY PAID FOR	PRESENT EXTRA
	Total (37 CFR 1.16(i))	*	Minus	**	=
Independent (37 CFR 1.16(h))	*	Minus	***	=	
Application Size Fee (37 CFR 1.16(s))					
FIRST PRESENTATION OF MULTIPLE DEPENDENT CLAIM (37 CFR 1.16(j))					

**SMALL ENTITY**

RATE(\$)	ADDITIONAL FEE(\$)
x =	
x =	
<b>TOTAL ADD'L FEE</b>	

**OR OTHER THAN SMALL ENTITY**

RATE(\$)	ADDITIONAL FEE(\$)
x =	
x =	
<b>TOTAL ADD'L FEE</b>	

(Column 1) (Column 2) (Column 3)

AMENDMENT B		CLAIMS REMAINING AFTER AMENDMENT		HIGHEST NUMBER PREVIOUSLY PAID FOR	PRESENT EXTRA
	Total (37 CFR 1.16(i))	*	Minus	**	=
Independent (37 CFR 1.16(h))	*	Minus	***	=	
Application Size Fee (37 CFR 1.16(s))					
FIRST PRESENTATION OF MULTIPLE DEPENDENT CLAIM (37 CFR 1.16(j))					

**SMALL ENTITY**

RATE(\$)	ADDITIONAL FEE(\$)
x =	
x =	
<b>TOTAL ADD'L FEE</b>	

**OR OTHER THAN SMALL ENTITY**

RATE(\$)	ADDITIONAL FEE(\$)
x =	
x =	
<b>TOTAL ADD'L FEE</b>	

\* If the entry in column 1 is less than the entry in column 2, write "0" in column 3.

\*\* If the "Highest Number Previously Paid For" IN THIS SPACE is less than 20, enter "20".

\*\*\* If the "Highest Number Previously Paid For" IN THIS SPACE is less than 3, enter "3".

The "Highest Number Previously Paid For" (Total or Independent) is the highest found in the appropriate box in column 1.

**IN THE UNITED STATES PATENT AND TRADEMARK OFFICE**

Inventor(s): Jin Ho LEE et al.	Group Art Unit: 2482
U.S. Serial No.: 14/825,825	Examiner: n/a
Filing Date: August 13, 2015	
Title: METHOD AND APPARATUS FOR PERFORMING INTRA-PREDICTION USING ADAPTIVE FILTER	

**REPLY TO NOTICE OF INCOMPLETE REPLY****Mail Stop Missing Parts**

The Commissioner for Patents  
P.O. Box 1450  
Alexandria VA 22313-1450

Dear Sir/Madam:

The applicant received the Notice of Incomplete Reply mailed October 23, 2015, maintaining the due dates of the Notice to File Corrected Application Papers ("the Notice") mailed August 28, 2015, setting a 2-month shortened statutory period for a reply ending on October 28, 2015. The Notice to File Corrected Application Papers required an amendment to the specification or replacement drawings in compliance with 37 CFR 1.84 for FIGS. 8-9. Enclosed is a copy of the Notice of Incomplete Reply.

In response, the applicant submits herewith replacement drawings in compliance with 37 CFR 1.84. Included is a marked up version along with a clean version to remove drawings labeled "FIG. 8" and "FIG. 9" and replace it with "FIG. 8." (FIG. 8 has been canceled and FIG. 9 has been renumbered to FIG. 8).

The applicant hereby asserts that the substitute specification filed herewith contains no new matter.

The USPTO is encouraged to contact the undersigned by telephone to discuss any issues remaining.

Respectfully submitted,  
Dated: October 26, 2015  
Electronic signature: /W. William Park/  
W. William Park, Reg. No. 55,523  
William Park & Associates Ltd.  
930 N. York Road, Suite 201  
Hinsdale IL 60521  
630-908-7652





UNITED STATES PATENT AND TRADEMARK OFFICE

UNITED STATES DEPARTMENT OF COMMERCE
United States Patent and Trademark Office
Address: COMMISSIONER FOR PATENTS
P.O. Box 1450
Alexandria, Virginia 22313-1450
www.uspto.gov

Table with 4 columns: APPLICATION NUMBER (14/825,825), FILING OR 371(C) DATE (08/13/2015), FIRST NAMED APPLICANT (Jin Ho LEE), ATTY. DOCKET NO./TITLE (PA0929-2C)

CONFIRMATION NO. 1431
FORMALITIES LETTER

96767
William Park & Associates LTD.
930 N. York Road, Suite 201
Hinsdale, IL 60521



Date Mailed: 10/23/2015

NOTICE OF INCOMPLETE REPLY (NONPROVISIONAL)

Filing Date Granted

The U.S. Patent and Trademark Office has received your reply on 10/15/2015 to the Notice to File Missing Parts (Notice) mailed 08/28/2015 and it has been entered into the nonprovisional application. The reply, however, does not include the following items required in the Notice. A complete reply must be timely filed to prevent ABANDONMENT of the above-identified application. Replies should be mailed to: Mail Stop Missing Parts, Commissioner for Patents, P.O. Box 1450, Alexandria VA 22313-1450.

Applicant is given TWO MONTHS from the date of the Notice to File Missing Parts (Notice) mailed 08/28/2015 within which to file all required items and pay any fees required below to avoid abandonment. Extensions of time may be obtained by filing a petition accompanied by the extension fee under the provisions of 37 CFR 1.136(a).

Items Required to Avoid Abandonment:

The required items noted below SHOULD be filed along with any items required above. The filing date of this nonprovisional application will be the date of receipt of the items required above.

The application is informal since it does not comply with the regulations for the reason(s) indicated below.

The required item(s) identified below must be timely submitted to avoid abandonment:

- A substitute specification in compliance with 37 CFR 1.52, 1.121(b)(3), and 1.125, is required. The substitute specification must be submitted with markings and be accompanied by a clean version (without markings) as set forth in 37 CFR 1.125(c) and a statement that the substitute specification contains no new matter (see 37 CFR 1.125(b)). The specification, claims, and/or abstract page(s) submitted is not acceptable and cannot be scanned or properly stored because:
• The application contains drawings, but the specification does not contain a brief description of the several views of the drawings as required by 37 CFR 1.74 and 37 CFR 1.77(b)(9).

Applicant is cautioned that correction of the above items may cause the specification and drawings page count to exceed 100 pages. If the specification and drawings exceed 100 pages, applicant will need to submit the required application size fee.

Replies must be received in the USPTO within the set time period or must include a proper Certificate of Mailing or Transmission under 37 CFR 1.8 with a mailing or transmission date within the set time period. For more information and a suggested format, see Form PTO/SB/92 and MPEP 512.

Replies should be mailed to:

Mail Stop Missing Parts  
Commissioner for Patents  
P.O. Box 1450  
Alexandria VA 22313-1450

Registered users of EFS-Web may alternatively submit their reply to this notice via EFS-Web, including a copy of this Notice and selecting the document description "Applicant response to Pre-Exam Formalities Notice".  
<https://portal.uspto.gov/authenticate/AuthenticateUserLocalEPF.html>

For more information about EFS-Web please call the USPTO Electronic Business Center at 1-866-217-9197 or visit our website at <http://www.uspto.gov/ebc>.

If you are not using EFS-Web to submit your reply, you must include a copy of this notice.

Questions about the contents of this notice and the requirements it sets forth should be directed to the Office of Data Management, Application Assistance Unit, at **(571) 272-4000** or **(571) 272-4200** or **1-888-786-0101**.

/dnguyen/

---

Marked Up Drawings

U.S. Serial No. 14/825,825

FIG. 1

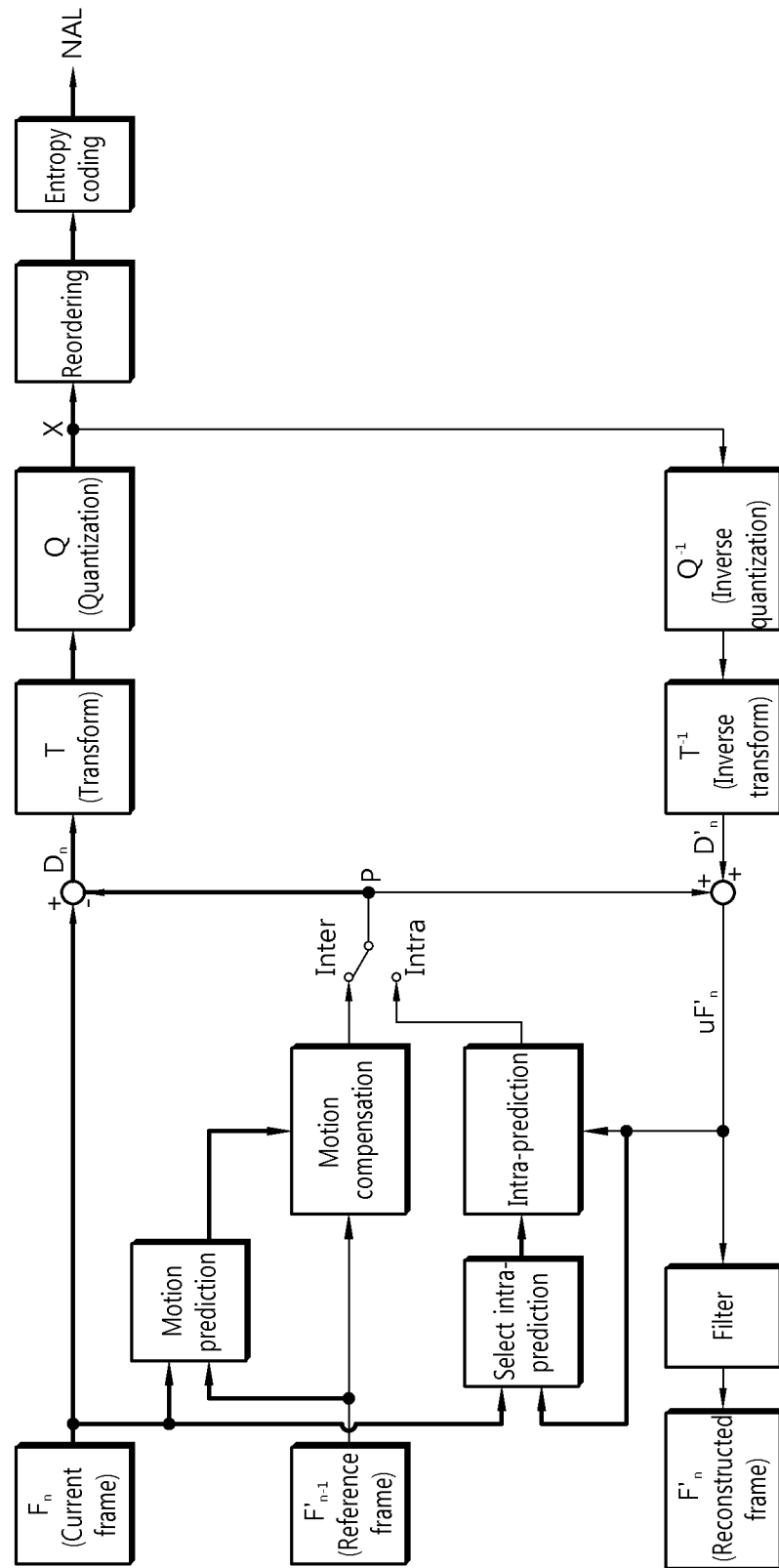

FIG. 2

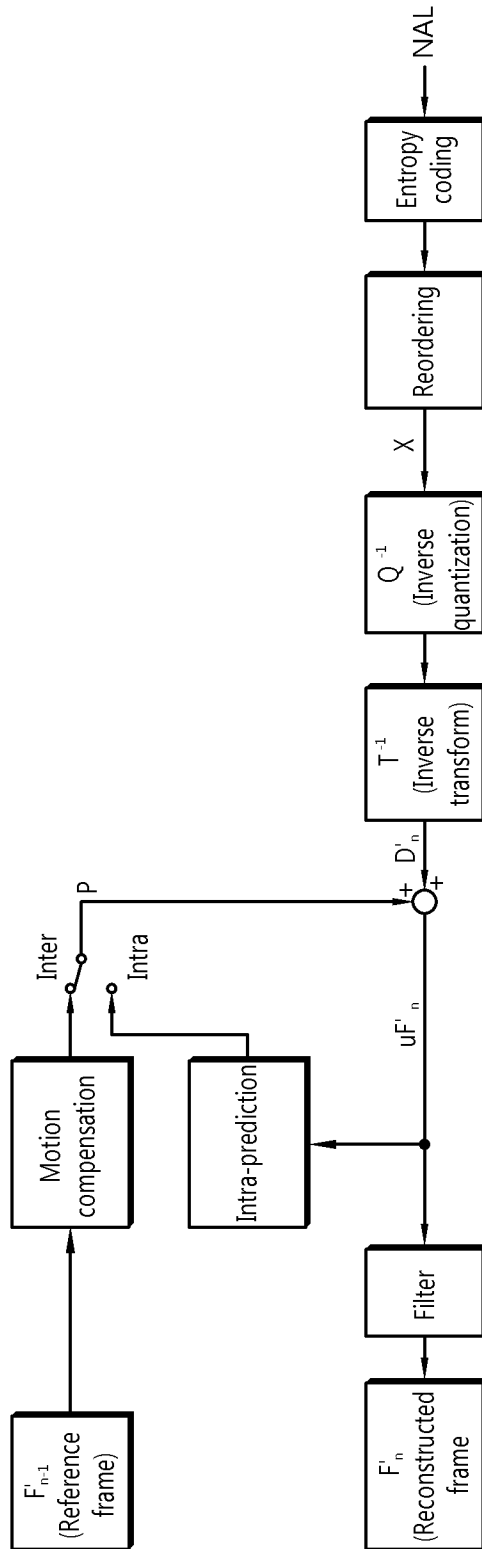

FIG. 3

M	A	B	C	D	E	F	G	H
I	a	b	c	d				
J	e	f	g	h				
K	i	j	k	l				
L	m	n	o	p				

# FIG. 4

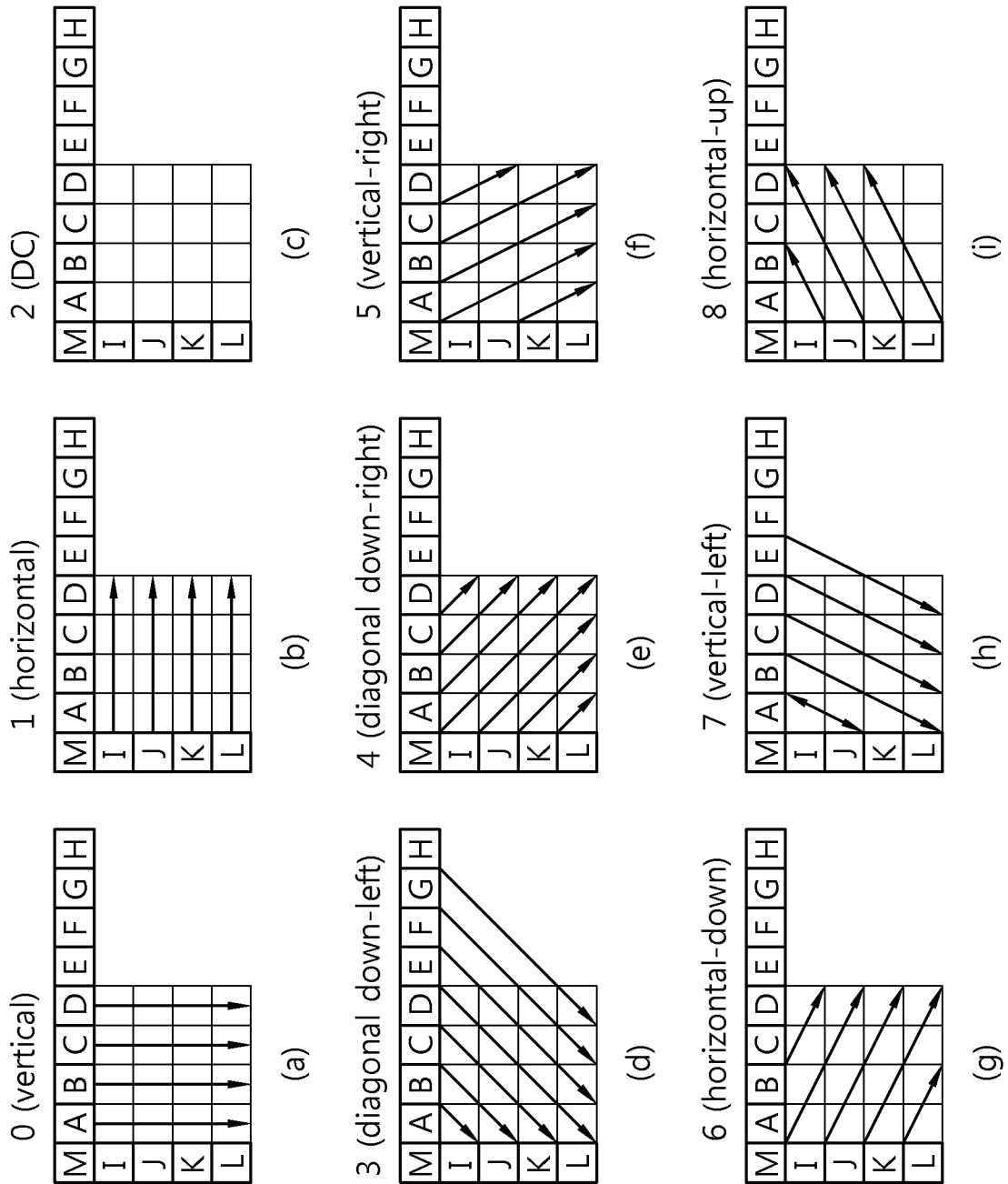

FIG. 5

Z	A	B	C	D	E	F	G	H	I	J	K	L	M	N	O	P
Q																
R																
S																
T																
U																
V																
W																
X																



FIG. 6

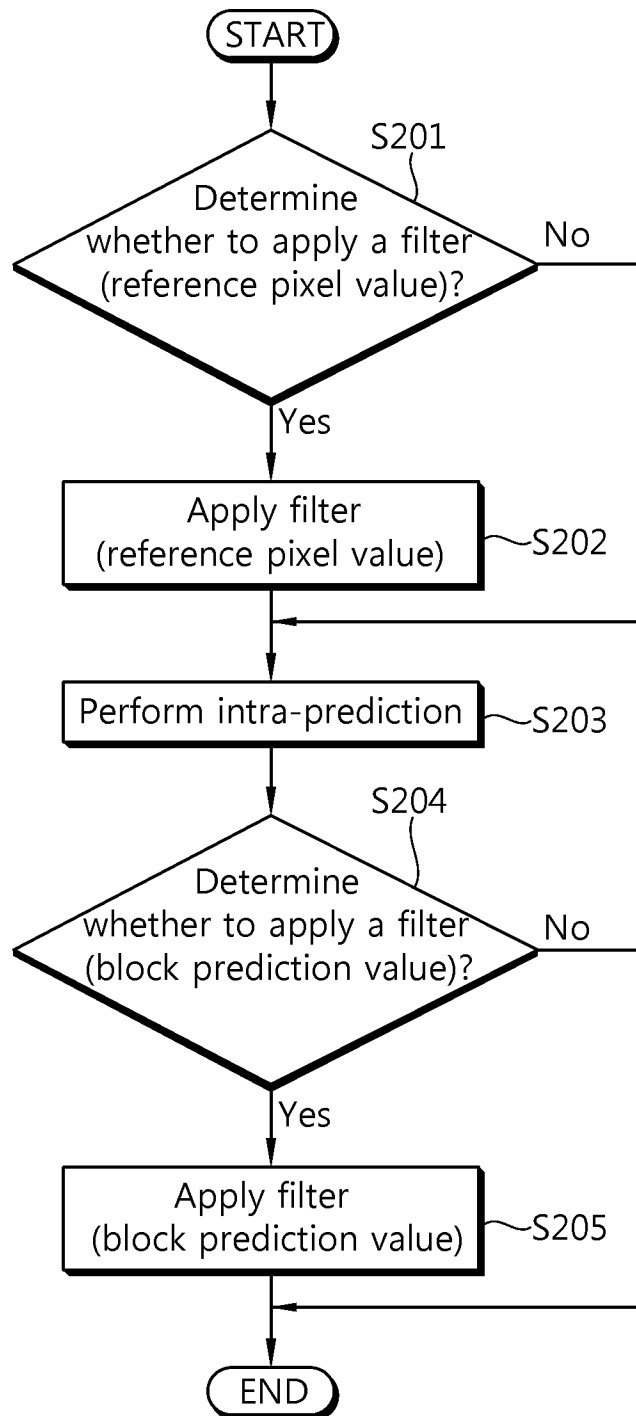

FIG. 7

Z	A	B	C	D	E	F	G	H	I	J	K	L	M	N	O	P
Q	a1	b1	c1	d1	e1	f1	g1	h1								
R	a2	b2	c2	d2	e2	f2	g2	h2								
S	a3	b3	...	...	...	...	...	...								
T	a4	b4	...	...	...	...	...	...								
U	a5	b5	...	...	...	...	...	...								
V	a6	b6	...	...	...	f6	g6	h6								
W	a7	b7	...	...	...	f7	g7	h7								
X	a8	b8	...	...	...	f8	g8	h8								

FIG. 8

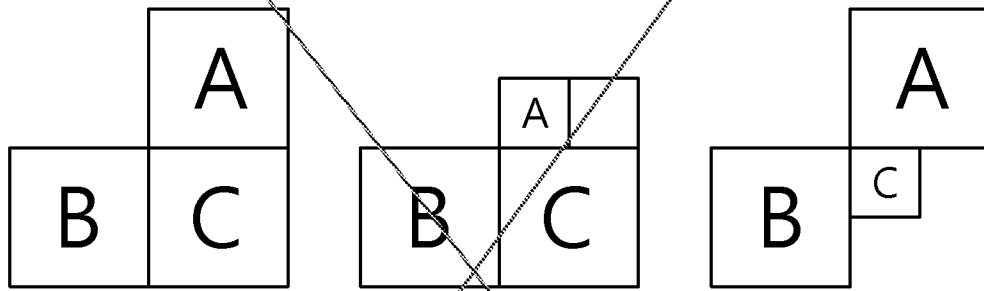
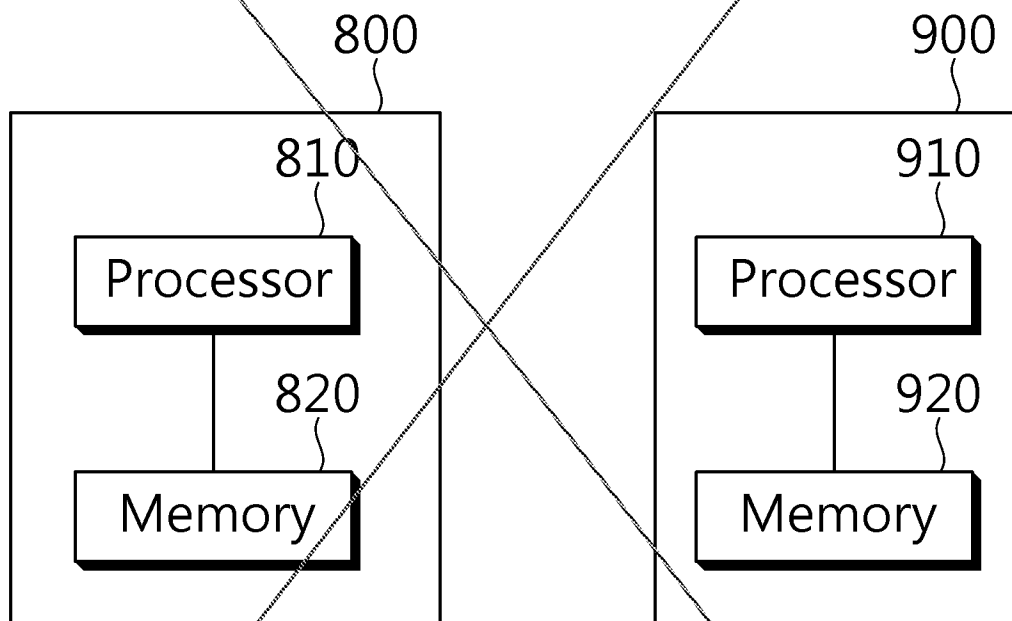

FIG. 9



Replacement Drawings

U.S. Serial No. 14/825,825

FIG. 1

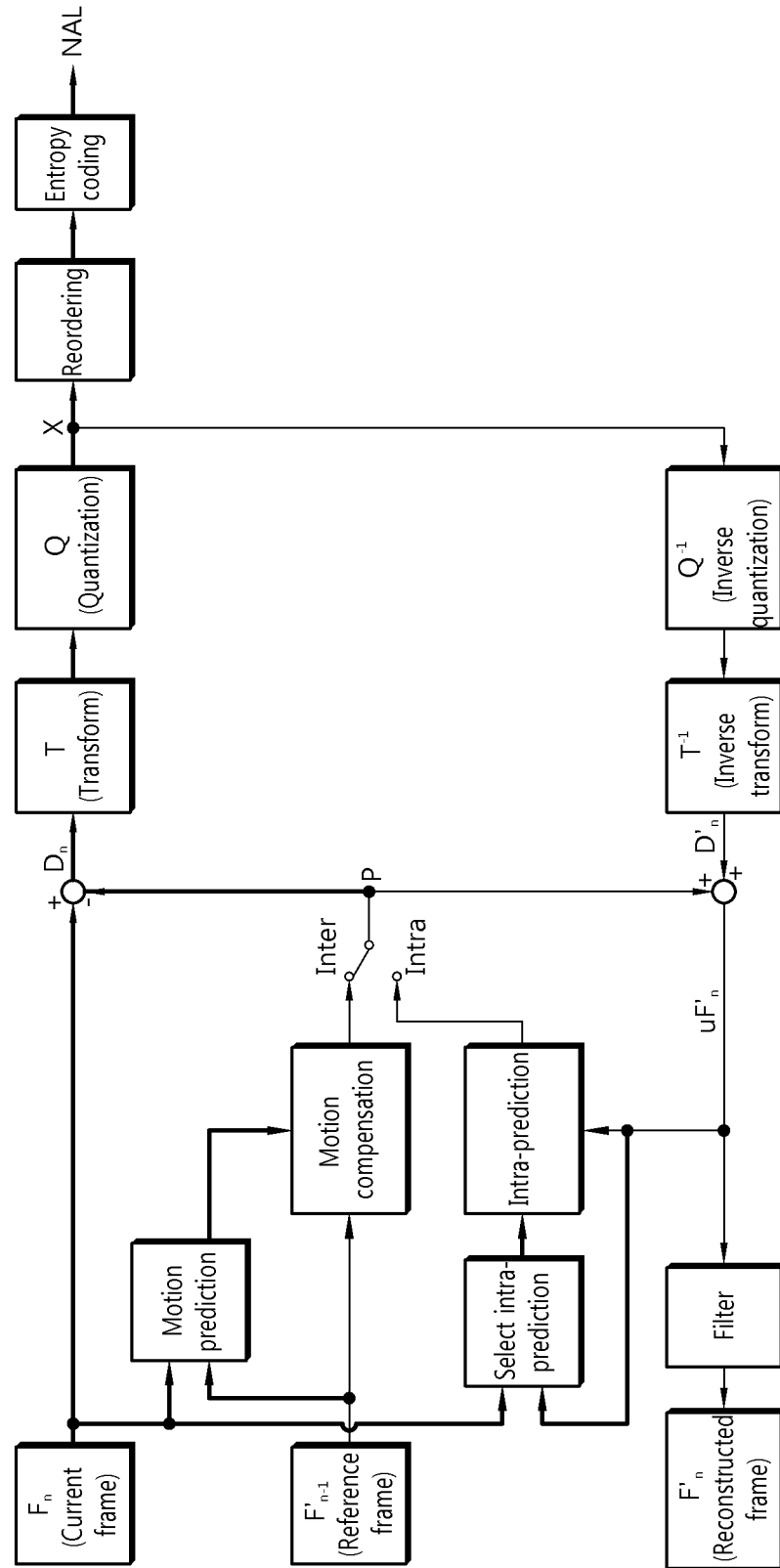

FIG. 2

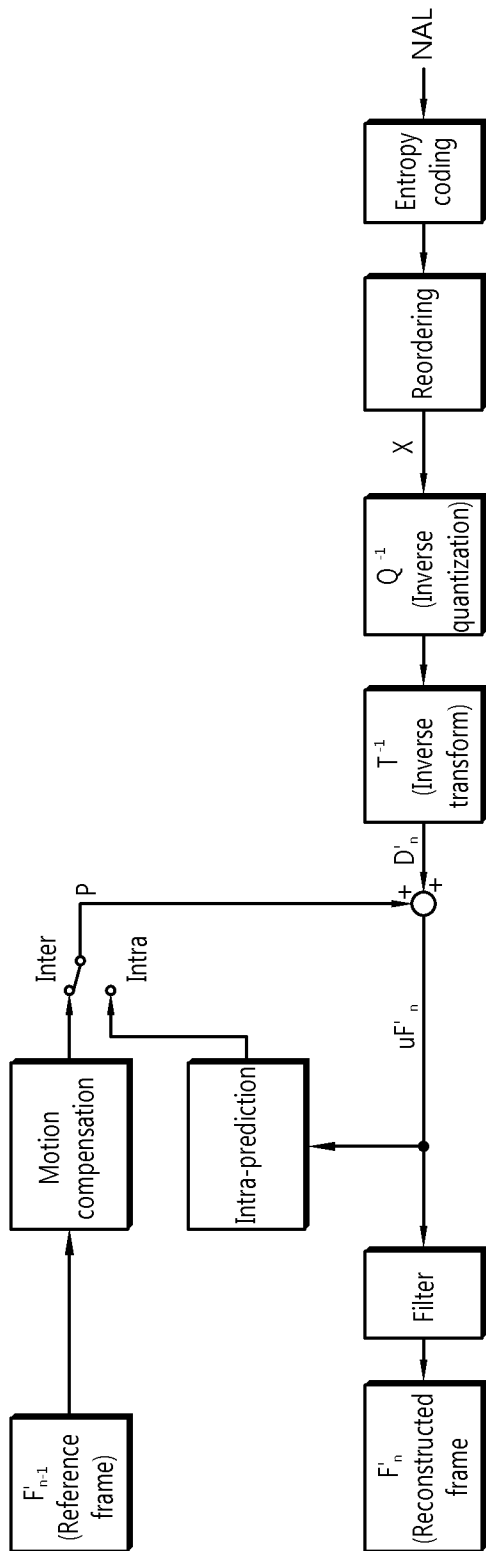

FIG. 3

M	A	B	C	D	E	F	G	H
I	a	b	c	d				
J	e	f	g	h				
K	i	j	k	l				
L	m	n	o	p				



# FIG. 4

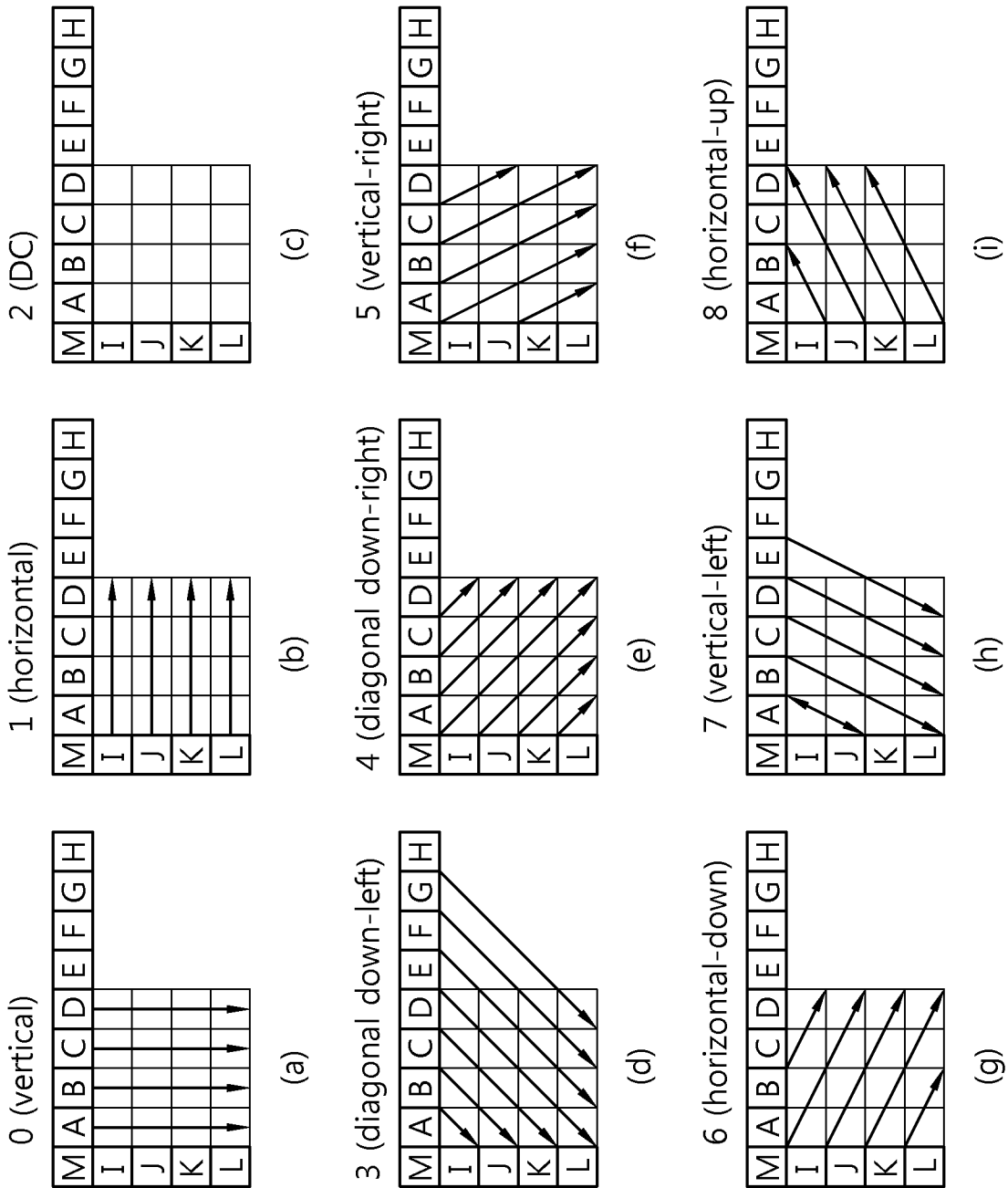

FIG. 5

Z	A	B	C	D	E	F	G	H	I	J	K	L	M	N	O	P
Q																
R																
S																
T																
U																
V																
W																
X																

FIG. 6

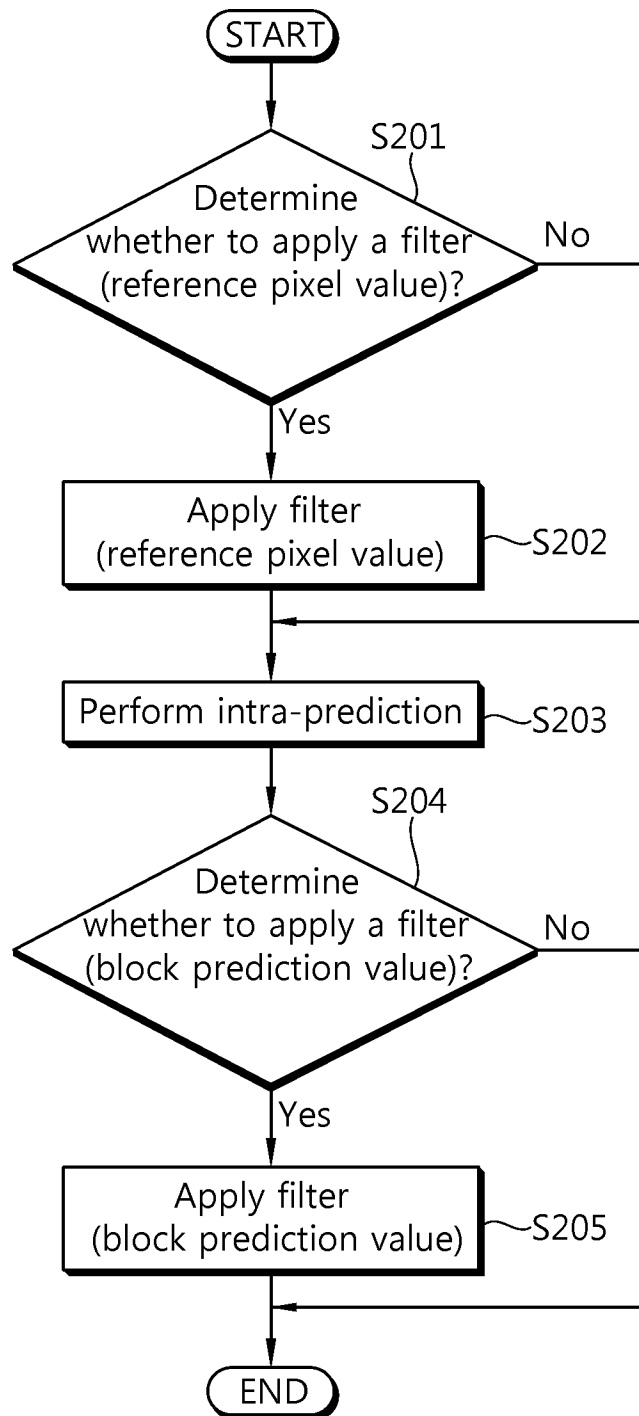
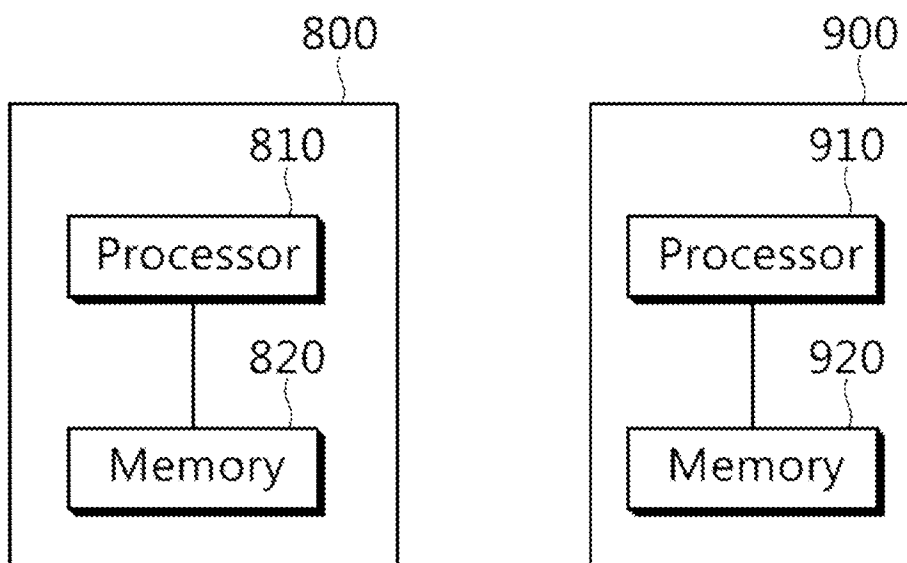

FIG. 7

	Z	A	B	C	D	E	F	G	H	I	J	K	L	M	N	O	P
Q	a1	b1	c1	d1	e1	f1	g1	h1									
R	a2	b2	c2	d2	e2	f2	g2	h2									
S	a3	b3	...	...	...	...	...	...									
T	a4	b4	...	...	...	...	...	...									
U	a5	b5	...	...	...	...	...	...									
V	a6	b6	...	...	...	...	f6	g6	h6								
W	a7	b7	...	...	...	...	f7	g7	h7								
X	a8	b8	...	...	...	...	f8	g8	h8								

FIG. 8



## Electronic Acknowledgement Receipt

<b>EFS ID:</b>	23895287
<b>Application Number:</b>	14825825
<b>International Application Number:</b>	
<b>Confirmation Number:</b>	1431
<b>Title of Invention:</b>	METHOD AND APPARATUS FOR PERFORMING INTRA-PREDICTION USING ADAPTIVE FILTER
<b>First Named Inventor/Applicant Name:</b>	Jin Ho LEE
<b>Customer Number:</b>	96767
<b>Filer:</b>	Woochoon William Park/Mariana Maxey
<b>Filer Authorized By:</b>	Woochoon William Park
<b>Attorney Docket Number:</b>	PA0929-2C
<b>Receipt Date:</b>	26-OCT-2015
<b>Filing Date:</b>	13-AUG-2015
<b>Time Stamp:</b>	19:04:11
<b>Application Type:</b>	Utility under 35 USC 111(a)

### Payment information:

Submitted with Payment	no
------------------------	----

### File Listing:

Document Number	Document Description	File Name	File Size(Bytes)/ Message Digest	Multi Part /.zip	Pages (if appl.)
1	Applicant Response to Pre-Exam Formalities Notice	PA0929-2C_Transmittal_with_copy_of_NIR.pdf	91736 <small>5762380968def9f15dfa2cd3e1512f96b951431a</small>	no	4

### Warnings:

### Information:

IPR2021-00827

2	Drawings-only black and white line drawings	PA0929-2C_Substitute_drawings.pdf	245029 b3819e137143b9b42ad2c26b62baea8522662314	no	19
---	---	-----------------------------------	--	----	----

**Warnings:**

**Information:**

<b>Total Files Size (in bytes):</b>	336765
-------------------------------------	--------

**This Acknowledgement Receipt evidences receipt on the noted date by the USPTO of the indicated documents, characterized by the applicant, and including page counts, where applicable. It serves as evidence of receipt similar to a Post Card, as described in MPEP 503.**

**New Applications Under 35 U.S.C. 111**

**If a new application is being filed and the application includes the necessary components for a filing date (see 37 CFR 1.53(b)-(d) and MPEP 506), a Filing Receipt (37 CFR 1.54) will be issued in due course and the date shown on this Acknowledgement Receipt will establish the filing date of the application.**

**National Stage of an International Application under 35 U.S.C. 371**

**If a timely submission to enter the national stage of an international application is compliant with the conditions of 35 U.S.C. 371 and other applicable requirements a Form PCT/DO/EO/903 indicating acceptance of the application as a national stage submission under 35 U.S.C. 371 will be issued in addition to the Filing Receipt, in due course.**

**New International Application Filed with the USPTO as a Receiving Office**

**If a new international application is being filed and the international application includes the necessary components for an international filing date (see PCT Article 11 and MPEP 1810), a Notification of the International Application Number and of the International Filing Date (Form PCT/RO/105) will be issued in due course, subject to prescriptions concerning national security, and the date shown on this Acknowledgement Receipt will establish the international filing date of the application.**

**PATENT APPLICATION FEE DETERMINATION RECORD**

Substitute for Form PTO-875

Application or Docket Number  
14/825,825

**APPLICATION AS FILED - PART I**

(Column 1) (Column 2)

FOR	NUMBER FILED	NUMBER EXTRA
BASIC FEE (37 CFR 1.16(a), (b), or (c))	N/A	N/A
SEARCH FEE (37 CFR 1.16(k), (l), or (m))	N/A	N/A
EXAMINATION FEE (37 CFR 1.16(o), (p), or (q))	N/A	N/A
TOTAL CLAIMS (37 CFR 1.16(j))	3	minus 20 = *
INDEPENDENT CLAIMS (37 CFR 1.16(h))	1	minus 3 = *
APPLICATION SIZE FEE (37 CFR 1.16(s))	If the specification and drawings exceed 100 sheets of paper, the application size fee due is \$310 (\$155 for small entity) for each additional 50 sheets or fraction thereof. See 35 U.S.C. 41(a)(1)(G) and 37 CFR 1.16(s).	
MULTIPLE DEPENDENT CLAIM PRESENT (37 CFR 1.16(j))		

\* If the difference in column 1 is less than zero, enter "0" in column 2.

**SMALL ENTITY**

RATE(\$)	FEE(\$)
N/A	70
N/A	300
N/A	360
x 40 =	0.00
x 210 =	0.00
	0.00
	0.00
<b>TOTAL</b>	<b>730</b>

**OR OTHER THAN SMALL ENTITY**

RATE(\$)	FEE(\$)
N/A	
N/A	
N/A	
<b>TOTAL</b>	

**APPLICATION AS AMENDED - PART II**

(Column 1) (Column 2) (Column 3)

AMENDMENT A		CLAIMS REMAINING AFTER AMENDMENT		HIGHEST NUMBER PREVIOUSLY PAID FOR	PRESENT EXTRA
	Total (37 CFR 1.16(j))	*	Minus	**	=
Independent (37 CFR 1.16(h))	*	Minus	***	=	
Application Size Fee (37 CFR 1.16(s))					
FIRST PRESENTATION OF MULTIPLE DEPENDENT CLAIM (37 CFR 1.16(j))					

**SMALL ENTITY**

RATE(\$)	ADDITIONAL FEE(\$)
x =	
x =	
<b>TOTAL ADD'L FEE</b>	

**OR OTHER THAN SMALL ENTITY**

RATE(\$)	ADDITIONAL FEE(\$)
x =	
x =	
<b>TOTAL ADD'L FEE</b>	

(Column 1) (Column 2) (Column 3)

AMENDMENT B		CLAIMS REMAINING AFTER AMENDMENT		HIGHEST NUMBER PREVIOUSLY PAID FOR	PRESENT EXTRA
	Total (37 CFR 1.16(j))	*	Minus	**	=
Independent (37 CFR 1.16(h))	*	Minus	***	=	
Application Size Fee (37 CFR 1.16(s))					
FIRST PRESENTATION OF MULTIPLE DEPENDENT CLAIM (37 CFR 1.16(j))					

**SMALL ENTITY**

RATE(\$)	ADDITIONAL FEE(\$)
x =	
x =	
<b>TOTAL ADD'L FEE</b>	

**OR OTHER THAN SMALL ENTITY**

RATE(\$)	ADDITIONAL FEE(\$)
x =	
x =	
<b>TOTAL ADD'L FEE</b>	

\* If the entry in column 1 is less than the entry in column 2, write "0" in column 3.

\*\* If the "Highest Number Previously Paid For" IN THIS SPACE is less than 20, enter "20".

\*\*\* If the "Highest Number Previously Paid For" IN THIS SPACE is less than 3, enter "3".

The "Highest Number Previously Paid For" (Total or Independent) is the highest found in the appropriate box in column 1.





UNITED STATES PATENT AND TRADEMARK OFFICE

UNITED STATES DEPARTMENT OF COMMERCE
United States Patent and Trademark Office
Address: COMMISSIONER FOR PATENTS
P.O. Box 1450
Alexandria, Virginia 22313-1450
www.uspto.gov

Table with 4 columns: APPLICATION NUMBER (14/825,825), FILING OR 371(C) DATE (08/13/2015), FIRST NAMED APPLICANT (Jin Ho LEE), ATTY. DOCKET NO./TITLE (PA0929-2C)

CONFIRMATION NO. 1431
FORMALITIES LETTER

96767
William Park & Associates LTD.
930 N. York Road, Suite 201
Hinsdale, IL 60521



Date Mailed: 10/23/2015

NOTICE OF INCOMPLETE REPLY (NONPROVISIONAL)

Filing Date Granted

The U.S. Patent and Trademark Office has received your reply on 10/15/2015 to the Notice to File Missing Parts (Notice) mailed 08/28/2015 and it has been entered into the nonprovisional application. The reply, however, does not include the following items required in the Notice. A complete reply must be timely filed to prevent ABANDONMENT of the above-identified application. Replies should be mailed to: Mail Stop Missing Parts, Commissioner for Patents, P.O. Box 1450, Alexandria VA 22313-1450.

Applicant is given TWO MONTHS from the date of the Notice to File Missing Parts (Notice) mailed 08/28/2015 within which to file all required items and pay any fees required below to avoid abandonment. Extensions of time may be obtained by filing a petition accompanied by the extension fee under the provisions of 37 CFR 1.136(a).

Items Required to Avoid Abandonment:

The required items noted below SHOULD be filed along with any items required above. The filing date of this nonprovisional application will be the date of receipt of the items required above.

The application is informal since it does not comply with the regulations for the reason(s) indicated below.

The required item(s) identified below must be timely submitted to avoid abandonment:

- A substitute specification in compliance with 37 CFR 1.52, 1.121(b)(3), and 1.125, is required. The substitute specification must be submitted with markings and be accompanied by a clean version (without markings) as set forth in 37 CFR 1.125(c) and a statement that the substitute specification contains no new matter (see 37 CFR 1.125(b)). The specification, claims, and/or abstract page(s) submitted is not acceptable and cannot be scanned or properly stored because:
• The application contains drawings, but the specification does not contain a brief description of the several views of the drawings as required by 37 CFR 1.74 and 37 CFR 1.77(b)(9).

Applicant is cautioned that correction of the above items may cause the specification and drawings page count to exceed 100 pages. If the specification and drawings exceed 100 pages, applicant will need to submit the required application size fee.

Replies must be received in the USPTO within the set time period or must include a proper Certificate of Mailing or Transmission under 37 CFR 1.8 with a mailing or transmission date within the set time period. For more information and a suggested format, see Form PTO/SB/92 and MPEP 512.

Replies should be mailed to:

Mail Stop Missing Parts  
Commissioner for Patents  
P.O. Box 1450  
Alexandria VA 22313-1450

Registered users of EFS-Web may alternatively submit their reply to this notice via EFS-Web, including a copy of this Notice and selecting the document description "Applicant response to Pre-Exam Formalities Notice".  
<https://portal.uspto.gov/authenticate/AuthenticateUserLocalEPF.html>

For more information about EFS-Web please call the USPTO Electronic Business Center at 1-866-217-9197 or visit our website at <http://www.uspto.gov/ebc>.

If you are not using EFS-Web to submit your reply, you must include a copy of this notice.

Questions about the contents of this notice and the requirements it sets forth should be directed to the Office of Data Management, Application Assistance Unit, at **(571) 272-4000** or **(571) 272-4200** or **1-888-786-0101**.

/dnguyen/

---

**IN THE UNITED STATES PATENT AND TRADEMARK OFFICE**

Inventor(s): Jin Ho LEE et al.	Group Art Unit: 2482
U.S. Serial No.: 14/825,825	Examiner: n/a
Filing Date: August 13, 2015	
Title: METHOD AND APPARATUS FOR PERFORMING INTRA-PREDICTION USING ADAPTIVE FILTER	

**REPLY TO NOTICE TO FILE CORRECTED APPLICATION PAPERS****Mail Stop Missing Parts**

The Commissioner for Patents  
P.O. Box 1450  
Alexandria VA 22313-1450

Sir:

In the Notice to File Corrected Application Papers ("the Notice") mailed August 28, 2015, setting a 2-month shortened statutory period for a reply ending on October 28, 2015, amendment to the specification or replacement drawings in compliance with 37 CFR 1.84 for FIGS. 8-9 were required.

In response, the applicant submits a **replacement** drawing for FIG. 8 in compliance with 37 CFR 1.84. The replacement drawing of FIG. 8 replaces the originally filed drawings labeled "FIG. 8" and "FIG. 9" (where FIG. 8 has been canceled and FIG. 9 has been renumbered to FIG. 8).

The USPTO is encouraged to contact the undersigned by telephone to discuss any issues remaining.

Respectfully submitted,

Dated: October 15, 2015

Electronic signature: /W. William Park/  
W. William Park, Reg. No. 55,523  
William Park & Associates Ltd.  
930 N. York Road, Suite 201  
Hinsdale IL 60521  
630-908-7652

Replacement Sheet  
U.S. Serial No. 14/825,825

FIG. 8

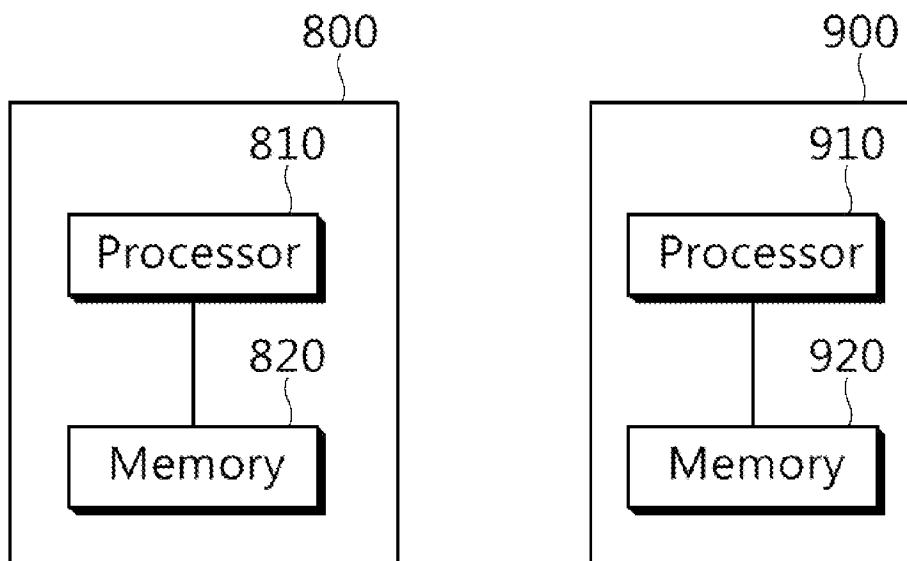

## Electronic Acknowledgement Receipt

<b>EFS ID:</b>	23791380
<b>Application Number:</b>	14825825
<b>International Application Number:</b>	
<b>Confirmation Number:</b>	1431
<b>Title of Invention:</b>	METHOD AND APPARATUS FOR PERFORMING INTRA-PREDICTION USING ADAPTIVE FILTER
<b>First Named Inventor/Applicant Name:</b>	Jin Ho LEE
<b>Customer Number:</b>	96767
<b>Filer:</b>	Woochoon William Park/Daniel Yu
<b>Filer Authorized By:</b>	Woochoon William Park
<b>Attorney Docket Number:</b>	PA0929-2C
<b>Receipt Date:</b>	15-OCT-2015
<b>Filing Date:</b>	13-AUG-2015
<b>Time Stamp:</b>	12:10:36
<b>Application Type:</b>	Utility under 35 USC 111(a)

### Payment information:

Submitted with Payment	no
------------------------	----

### File Listing:

Document Number	Document Description	File Name	File Size(Bytes)/ Message Digest	Multi Part /.zip	Pages (if appl.)
1	Miscellaneous Incoming Letter	PA0929-2C_Reply_to_NFCAP. pdf	81756 <small>9e189f8dd771eeb2ffe476950c574b2df7bfc9ef</small>	no	2

### Warnings:

### Information:

IPR2021-00827

**This Acknowledgement Receipt evidences receipt on the noted date by the USPTO of the indicated documents, characterized by the applicant, and including page counts, where applicable. It serves as evidence of receipt similar to a Post Card, as described in MPEP 503.**

**New Applications Under 35 U.S.C. 111**

**If a new application is being filed and the application includes the necessary components for a filing date (see 37 CFR 1.53(b)-(d) and MPEP 506), a Filing Receipt (37 CFR 1.54) will be issued in due course and the date shown on this Acknowledgement Receipt will establish the filing date of the application.**

**National Stage of an International Application under 35 U.S.C. 371**

**If a timely submission to enter the national stage of an international application is compliant with the conditions of 35 U.S.C. 371 and other applicable requirements a Form PCT/DO/EO/903 indicating acceptance of the application as a national stage submission under 35 U.S.C. 371 will be issued in addition to the Filing Receipt, in due course.**

**New International Application Filed with the USPTO as a Receiving Office**

**If a new international application is being filed and the international application includes the necessary components for an international filing date (see PCT Article 11 and MPEP 1810), a Notification of the International Application Number and of the International Filing Date (Form PCT/RO/105) will be issued in due course, subject to prescriptions concerning national security, and the date shown on this Acknowledgement Receipt will establish the international filing date of the application.**

**PATENT APPLICATION FEE DETERMINATION RECORD**

Substitute for Form PTO-875

Application or Docket Number  
14/825,825

**APPLICATION AS FILED - PART I**

(Column 1) (Column 2)

FOR	NUMBER FILED	NUMBER EXTRA
BASIC FEE (37 CFR 1.16(a), (b), or (c))	N/A	N/A
SEARCH FEE (37 CFR 1.16(k), (l), or (m))	N/A	N/A
EXAMINATION FEE (37 CFR 1.16(o), (p), or (q))	N/A	N/A
TOTAL CLAIMS (37 CFR 1.16(j))	3	minus 20 = *
INDEPENDENT CLAIMS (37 CFR 1.16(h))	1	minus 3 = *
APPLICATION SIZE FEE (37 CFR 1.16(s))	If the specification and drawings exceed 100 sheets of paper, the application size fee due is \$310 (\$155 for small entity) for each additional 50 sheets or fraction thereof. See 35 U.S.C. 41(a)(1)(G) and 37 CFR 1.16(s).	
MULTIPLE DEPENDENT CLAIM PRESENT (37 CFR 1.16(j))		

\* If the difference in column 1 is less than zero, enter "0" in column 2.

**SMALL ENTITY**

RATE(\$)	FEE(\$)
N/A	70
N/A	300
N/A	360
x 40 =	0.00
x 210 =	0.00
	0.00
	0.00
<b>TOTAL</b>	<b>730</b>

**OR OTHER THAN SMALL ENTITY**

RATE(\$)	FEE(\$)
N/A	
N/A	
N/A	
<b>TOTAL</b>	

**APPLICATION AS AMENDED - PART II**

(Column 1) (Column 2) (Column 3)

AMENDMENT A		CLAIMS REMAINING AFTER AMENDMENT		HIGHEST NUMBER PREVIOUSLY PAID FOR	PRESENT EXTRA
	Total (37 CFR 1.16(i))	*	Minus	**	=
	Independent (37 CFR 1.16(h))	*	Minus	***	=
	Application Size Fee (37 CFR 1.16(s))				
FIRST PRESENTATION OF MULTIPLE DEPENDENT CLAIM (37 CFR 1.16(j))					

**SMALL ENTITY**

RATE(\$)	ADDITIONAL FEE(\$)
x =	
x =	
<b>TOTAL ADD'L FEE</b>	

**OR OTHER THAN SMALL ENTITY**

RATE(\$)	ADDITIONAL FEE(\$)
x =	
x =	
<b>TOTAL ADD'L FEE</b>	

(Column 1) (Column 2) (Column 3)

AMENDMENT B		CLAIMS REMAINING AFTER AMENDMENT		HIGHEST NUMBER PREVIOUSLY PAID FOR	PRESENT EXTRA
	Total (37 CFR 1.16(i))	*	Minus	**	=
	Independent (37 CFR 1.16(h))	*	Minus	***	=
	Application Size Fee (37 CFR 1.16(s))				
FIRST PRESENTATION OF MULTIPLE DEPENDENT CLAIM (37 CFR 1.16(j))					

**SMALL ENTITY**

RATE(\$)	ADDITIONAL FEE(\$)
x =	
x =	
<b>TOTAL ADD'L FEE</b>	

**OR OTHER THAN SMALL ENTITY**

RATE(\$)	ADDITIONAL FEE(\$)
x =	
x =	
<b>TOTAL ADD'L FEE</b>	

\* If the entry in column 1 is less than the entry in column 2, write "0" in column 3.  
 \*\* If the "Highest Number Previously Paid For" IN THIS SPACE is less than 20, enter "20".  
 \*\*\* If the "Highest Number Previously Paid For" IN THIS SPACE is less than 3, enter "3".  
 The "Highest Number Previously Paid For" (Total or Independent) is the highest found in the appropriate box in column 1.



UNITED STATES PATENT AND TRADEMARK OFFICE

UNITED STATES DEPARTMENT OF COMMERCE
United States Patent and Trademark Office
Address: COMMISSIONER FOR PATENTS
P.O. Box 1450
Alexandria, Virginia 22313-1450
www.uspto.gov

Table with 7 columns: APPLICATION NUMBER, FILING or 371(c) DATE, GRP ART UNIT, FIL FEE REC'D, ATTY. DOCKET NO, TOT CLAIMS, IND CLAIMS. Row 1: 14/825,825, 08/13/2015, 2482, 730, PA0929-2C, 3, 1

CONFIRMATION NO. 1431

FILING RECEIPT

96767
William Park & Associates LTD.
930 N. York Road, Suite 201
Hinsdale, IL 60521



Date Mailed: 08/28/2015

Receipt is acknowledged of this non-provisional patent application. The application will be taken up for examination in due course. Applicant will be notified as to the results of the examination. Any correspondence concerning the application must include the following identification information: the U.S. APPLICATION NUMBER, FILING DATE, NAME OF APPLICANT, and TITLE OF INVENTION. Fees transmitted by check or draft are subject to collection. Please verify the accuracy of the data presented on this receipt. If an error is noted on this Filing Receipt, please submit a written request for a Filing Receipt Correction. Please provide a copy of this Filing Receipt with the changes noted thereon. If you received a "Notice to File Missing Parts" for this application, please submit any corrections to this Filing Receipt with your reply to the Notice. When the USPTO processes the reply to the Notice, the USPTO will generate another Filing Receipt incorporating the requested corrections

Inventor(s)

Jin Ho LEE, Daejeon-si, KOREA, REPUBLIC OF;
Hui Yong KIM, Daejeon-si, KOREA, REPUBLIC OF;
Se Yoon JEONG, Daejeon-si, KOREA, REPUBLIC OF;
Suk Hee CHO, Daejeon-si, KOREA, REPUBLIC OF;
Ha Hyun LEE, Seoul, KOREA, REPUBLIC OF;
Jong Ho KIM, Daejeon-si, KOREA, REPUBLIC OF;
Sung Chang LIM, Daejeon-si, KOREA, REPUBLIC OF;
Jin Soo CHOI, Daejeon-si, KOREA, REPUBLIC OF;
Jin Woong KIM, Daejeon-si, KOREA, REPUBLIC OF;
Chie Teuk AHN, Daejeon-si, KOREA, REPUBLIC OF;

Applicant(s)

Electronics and Telecommunications Research Institute, Daejeon, KOREA, REPUBLIC OF;

Power of Attorney: The patent practitioners associated with Customer Number 96767

Domestic Priority data as claimed by applicant

This application is a CON of 13/640,014 10/08/2012

Foreign Applications for which priority is claimed (You may be eligible to benefit from the Patent Prosecution Highway program at the USPTO. Please see http://www.uspto.gov for more information.) - None.

Foreign application information must be provided in an Application Data Sheet in order to constitute a claim to foreign priority. See 37 CFR 1.55 and 1.76.

Permission to Access - A proper Authorization to Permit Access to Application by Participating Offices (PTO/SB/39 or its equivalent) has been received by the USPTO.



**If Required, Foreign Filing License Granted:** 08/27/2015

The country code and number of your priority application, to be used for filing abroad under the Paris Convention, is **US 14/825,825**

**Projected Publication Date:** To Be Determined - pending completion of Corrected Papers

**Non-Publication Request:** No

**Early Publication Request:** No

**\*\* SMALL ENTITY \*\***

**Title**

METHOD AND APPARATUS FOR PERFORMING INTRA-PREDICTION USING ADAPTIVE FILTER

**Preliminary Class**

375

**Statement under 37 CFR 1.55 or 1.78 for AIA (First Inventor to File) Transition Applications:** No

### **PROTECTING YOUR INVENTION OUTSIDE THE UNITED STATES**

Since the rights granted by a U.S. patent extend only throughout the territory of the United States and have no effect in a foreign country, an inventor who wishes patent protection in another country must apply for a patent in a specific country or in regional patent offices. Applicants may wish to consider the filing of an international application under the Patent Cooperation Treaty (PCT). An international (PCT) application generally has the same effect as a regular national patent application in each PCT-member country. The PCT process **simplifies** the filing of patent applications on the same invention in member countries, but **does not result** in a grant of "an international patent" and does not eliminate the need of applicants to file additional documents and fees in countries where patent protection is desired.

Almost every country has its own patent law, and a person desiring a patent in a particular country must make an application for patent in that country in accordance with its particular laws. Since the laws of many countries differ in various respects from the patent law of the United States, applicants are advised to seek guidance from specific foreign countries to ensure that patent rights are not lost prematurely.

Applicants also are advised that in the case of inventions made in the United States, the Director of the USPTO must issue a license before applicants can apply for a patent in a foreign country. The filing of a U.S. patent application serves as a request for a foreign filing license. The application's filing receipt contains further information and guidance as to the status of applicant's license for foreign filing.

Applicants may wish to consult the USPTO booklet, "General Information Concerning Patents" (specifically, the section entitled "Treaties and Foreign Patents") for more information on timeframes and deadlines for filing foreign patent applications. The guide is available either by contacting the USPTO Contact Center at 800-786-9199, or it can be viewed on the USPTO website at <http://www.uspto.gov/web/offices/pac/doc/general/index.html>.

For information on preventing theft of your intellectual property (patents, trademarks and copyrights), you may wish to consult the U.S. Government website, <http://www.stopfakes.gov>. Part of a Department of Commerce initiative, this website includes self-help "toolkits" giving innovators guidance on how to protect intellectual property in specific countries such as China, Korea and Mexico. For questions regarding patent enforcement issues, applicants may call the U.S. Government hotline at 1-866-999-HALT (1-866-999-4258).

**LICENSE FOR FOREIGN FILING UNDER**  
**Title 35, United States Code, Section 184**  
**Title 37, Code of Federal Regulations, 5.11 & 5.15**

**GRANTED**

The applicant has been granted a license under 35 U.S.C. 184, if the phrase "IF REQUIRED, FOREIGN FILING LICENSE GRANTED" followed by a date appears on this form. Such licenses are issued in all applications where the conditions for issuance of a license have been met, regardless of whether or not a license may be required as set forth in 37 CFR 5.15. The scope and limitations of this license are set forth in 37 CFR 5.15(a) unless an earlier license has been issued under 37 CFR 5.15(b). The license is subject to revocation upon written notification. The date indicated is the effective date of the license, unless an earlier license of similar scope has been granted under 37 CFR 5.13 or 5.14.

This license is to be retained by the licensee and may be used at any time on or after the effective date thereof unless it is revoked. This license is automatically transferred to any related applications(s) filed under 37 CFR 1.53(d). This license is not retroactive.

The grant of a license does not in any way lessen the responsibility of a licensee for the security of the subject matter as imposed by any Government contract or the provisions of existing laws relating to espionage and the national security or the export of technical data. Licensees should apprise themselves of current regulations especially with respect to certain countries, of other agencies, particularly the Office of Defense Trade Controls, Department of State (with respect to Arms, Munitions and Implements of War (22 CFR 121-128)); the Bureau of Industry and Security, Department of Commerce (15 CFR parts 730-774); the Office of Foreign Assets Control, Department of Treasury (31 CFR Parts 500+) and the Department of Energy.

**NOT GRANTED**

No license under 35 U.S.C. 184 has been granted at this time, if the phrase "IF REQUIRED, FOREIGN FILING LICENSE GRANTED" DOES NOT appear on this form. Applicant may still petition for a license under 37 CFR 5.12, if a license is desired before the expiration of 6 months from the filing date of the application. If 6 months has lapsed from the filing date of this application and the licensee has not received any indication of a secrecy order under 35 U.S.C. 181, the licensee may foreign file the application pursuant to 37 CFR 5.15(b).

---

***SelectUSA***

The United States represents the largest, most dynamic marketplace in the world and is an unparalleled location for business investment, innovation, and commercialization of new technologies. The U.S. offers tremendous resources and advantages for those who invest and manufacture goods here. Through SelectUSA, our nation works to promote and facilitate business investment. SelectUSA provides information assistance to the international investor community; serves as an ombudsman for existing and potential investors; advocates on behalf of U.S. cities, states, and regions competing for global investment; and counsels U.S. economic development organizations on investment attraction best practices. To learn more about why the United States is the best country in the world to develop technology, manufacture products, deliver services, and grow your business, visit <http://www.SelectUSA.gov> or call +1-202-482-6800.



UNITED STATES PATENT AND TRADEMARK OFFICE

UNITED STATES DEPARTMENT OF COMMERCE
United States Patent and Trademark Office
Address: COMMISSIONER FOR PATENTS
P.O. Box 1450
Alexandria, Virginia 22313-1450
www.uspto.gov

Table with 4 columns: APPLICATION NUMBER (14/825,825), FILING OR 371(C) DATE (08/13/2015), FIRST NAMED APPLICANT (Jin Ho LEE), ATTY. DOCKET NO./TITLE (PA0929-2C)

CONFIRMATION NO. 1431

FORMALITIES LETTER



96767
William Park & Associates LTD.
930 N. York Road, Suite 201
Hinsdale, IL 60521

Date Mailed: 08/28/2015

NOTICE TO FILE CORRECTED APPLICATION PAPERS

Filing Date Granted

An application number and filing date have been accorded to this application. The application is informal since it does not comply with the regulations for the reason(s) indicated below. Applicant is given TWO MONTHS from the date of this Notice within which to correct the informalities indicated below. Extensions of time may be obtained by filing a petition accompanied by the extension fee under the provisions of 37 CFR 1.136(a).

The required item(s) identified below must be timely submitted to avoid abandonment:

- A substitute specification in compliance with 37 CFR 1.52, 1.121(b)(3), and 1.125, is required. The substitute specification must be submitted with markings and be accompanied by a clean version (without markings) as set forth in 37 CFR 1.125(c) and a statement that the substitute specification contains no new matter (see 37 CFR 1.125(b)). The specification, claims, and/or abstract page(s) submitted is not acceptable and cannot be scanned or properly stored because:
The application contains drawings, but the specification does not contain a brief description of the several views of the drawings as required by 37 CFR 1.74 and 37 CFR 1.77(b)(9).

Applicant is cautioned that correction of the above items may cause the specification and drawings page count to exceed 100 pages. If the specification and drawings exceed 100 pages, applicant will need to submit the required application size fee.

Replies must be received in the USPTO within the set time period or must include a proper Certificate of Mailing or Transmission under 37 CFR 1.8 with a mailing or transmission date within the set time period. For more information and a suggested format, see Form PTO/SB/92 and MPEP 512.

Replies should be mailed to:

Mail Stop Missing Parts  
Commissioner for Patents  
P.O. Box 1450  
Alexandria VA 22313-1450

Registered users of EFS-Web may alternatively submit their reply to this notice via EFS-Web, including a copy of this Notice and selecting the document description "Applicant response to Pre-Exam Formalities Notice".  
<https://portal.uspto.gov/authenticate/AuthenticateUserLocalEPF.html>

For more information about EFS-Web please call the USPTO Electronic Business Center at 1-866-217-9197 or visit our website at <http://www.uspto.gov/ebc>.

If you are not using EFS-Web to submit your reply, you must include a copy of this notice.

Questions about the contents of this notice and the requirements it sets forth should be directed to the Office of Data Management, Application Assistance Unit, at **(571) 272-4000** or **(571) 272-4200** or **1-888-786-0101**.

/spkannathip/

---



UNITED STATES PATENT AND TRADEMARK OFFICE

UNITED STATES DEPARTMENT OF COMMERCE
United States Patent and Trademark Office
Address: COMMISSIONER FOR PATENTS
P.O. Box 1450
Alexandria, Virginia 22313-1450
www.uspto.gov

Table with 4 columns: APPLICATION NUMBER (14/825,825), FILING OR 371(C) DATE (08/13/2015), FIRST NAMED APPLICANT (Jin Ho LEE), ATTY. DOCKET NO./TITLE (PA0929-2C)

CONFIRMATION NO. 1431

IMPROPER CFR REQUEST



96767
William Park & Associates LTD.
930 N. York Road, Suite 201
Hinsdale, IL 60521

Date Mailed: 08/28/2015

RESPONSE TO REQUEST FOR CORRECTED FILING RECEIPT

Continuity, Priority Claims, Petitions, and Non-Publication Requests

In response to your request for a corrected Filing Receipt, the Office is unable to comply with your request because:

Improper Priority Claim(s) to Prior-Filed Foreign Application(s)

The instant application was not filed within twelve (12) months from the filing date of the prior-filed foreign application, and there is no benefit claim to an intermediate nonprovisional or international application designating the United States filed within 12 months of the filing date of the foreign application.

Alternatively, if the instant application (or intermediate application) was filed within 14 months of the prior foreign application, applicant may file a petition (in the instant application) to restore the right of priority if the delay in filing the application within the 12 month time period was unintentional.

For applications filed on or after September 16, 2012, applicant must submit a corrected application data sheet (ADS) to include a foreign priority claim.

Timeliness: The required reference for the benefit claim to an intermediate nonprovisional or international application designating the United States must be filed during the pendency of the instant application and within the later of: (1) four months from the actual filing date of the instant application, or the national stage commencement date if the instant application is a national stage application under 35 U.S.C. 371; or (2) sixteen months from the filing date of the prior-filed application.

Questions about the contents of this notice and the requirements it sets forth should be directed to the Office of Data Management, Application Assistance Unit, at (571) 272-4000 or (571) 272-4200 or 1-888-786-0101.

/spkannathip/

---

<b>INFORMATION DISCLOSURE STATEMENT BY APPLICANT</b> ( Not for submission under 37 CFR 1.99)	Application Number		14825825	
	Filing Date		2015-08-13	
	First Named Inventor	Jin Ho LEE		
	Art Unit			
	Examiner Name			
	Attorney Docket Number		PA0929-2C	

U.S.PATENTS						Remove
Examiner Initial*	Cite No	Patent Number	Kind Code <sup>1</sup>	Issue Date	Name of Patentee or Applicant of cited Document	Pages,Columns,Lines where Relevant Passages or Relevant Figures Appear
	1					

If you wish to add additional U.S. Patent citation information please click the Add button. Add

U.S.PATENT APPLICATION PUBLICATIONS						Remove
Examiner Initial*	Cite No	Publication Number	Kind Code <sup>1</sup>	Publication Date	Name of Patentee or Applicant of cited Document	Pages,Columns,Lines where Relevant Passages or Relevant Figures Appear
	1					

If you wish to add additional U.S. Published Application citation information please click the Add button. Add

FOREIGN PATENT DOCUMENTS								Remove
Examiner Initial*	Cite No	Foreign Document Number <sup>3</sup>	Country Code <sup>2</sup> j	Kind Code <sup>4</sup>	Publication Date	Name of Patentee or Applicant of cited Document	Pages,Columns,Lines where Relevant Passages or Relevant Figures Appear	T <sup>5</sup>
	1	2012134085	WO	A2	2012-10-04	IBEX PT HOLDINGS CO., LTD.		<input type="checkbox"/>

If you wish to add additional Foreign Patent Document citation information please click the Add button Add

NON-PATENT LITERATURE DOCUMENTS				Remove
Examiner Initials*	Cite No	Include name of the author (in CAPITAL LETTERS), title of the article (when appropriate), title of the item (book, magazine, journal, serial, symposium, catalog, etc), date, pages(s), volume-issue number(s), publisher, city and/or country where published.		T <sup>5</sup>

<b>INFORMATION DISCLOSURE STATEMENT BY APPLICANT</b> ( Not for submission under 37 CFR 1.99)	Application Number		14825825	
	Filing Date		2015-08-13	
	First Named Inventor	Jin Ho LEE		
	Art Unit			
	Examiner Name			
	Attorney Docket Number		PA0929-2C	

1	Hui Yong KIM et al., Description of video coding technology proposal by ETRI, JCT-VC, April 19, 2010, pgs. 1-9, ETRI, Daejeon, South Korea.	<input type="checkbox"/>
---	---	--------------------------

If you wish to add additional non-patent literature document citation information please click the Add button **Add**

**EXAMINER SIGNATURE**

Examiner Signature	Date Considered
--------------------	-----------------

\*EXAMINER: Initial if reference considered, whether or not citation is in conformance with MPEP 609. Draw line through a citation if not in conformance and not considered. Include copy of this form with next communication to applicant.

<sup>1</sup> See Kind Codes of USPTO Patent Documents at [www.USPTO.GOV](http://www.USPTO.GOV) or MPEP 901.04. <sup>2</sup> Enter office that issued the document, by the two-letter code (WIPO Standard ST.3). <sup>3</sup> For Japanese patent documents, the indication of the year of the reign of the Emperor must precede the serial number of the patent document. <sup>4</sup> Kind of document by the appropriate symbols as indicated on the document under WIPO Standard ST.16 if possible. <sup>5</sup> Applicant is to place a check mark here if English language translation is attached.



<b>INFORMATION DISCLOSURE STATEMENT BY APPLICANT</b> ( Not for submission under 37 CFR 1.99)	Application Number	14825825
	Filing Date	2015-08-13
	First Named Inventor	Jin Ho LEE
	Art Unit	
	Examiner Name	
	Attorney Docket Number	PA0929-2C

**CERTIFICATION STATEMENT**

Please see 37 CFR 1.97 and 1.98 to make the appropriate selection(s):

That each item of information contained in the information disclosure statement was first cited in any communication from a foreign patent office in a counterpart foreign application not more than three months prior to the filing of the information disclosure statement. See 37 CFR 1.97(e)(1).

**OR**

That no item of information contained in the information disclosure statement was cited in a communication from a foreign patent office in a counterpart foreign application, and, to the knowledge of the person signing the certification after making reasonable inquiry, no item of information contained in the information disclosure statement was known to any individual designated in 37 CFR 1.56(c) more than three months prior to the filing of the information disclosure statement. See 37 CFR 1.97(e)(2).

See attached certification statement.

Fee set forth in 37 CFR 1.17 (p) has been submitted herewith.

None

**SIGNATURE**

A signature of the applicant or representative is required in accordance with CFR 1.33, 10.18. Please see CFR 1.4(d) for the form of the signature.

Signature	/Woochoon W. Park/	Date (YYYY-MM-DD)	2015-08-25
Name/Print	Woochoon W. Park	Registration Number	55523

This collection of information is required by 37 CFR 1.97 and 1.98. The information is required to obtain or retain a benefit by the public which is to file (and by the USPTO to process) an application. Confidentiality is governed by 35 U.S.C. 122 and 37 CFR 1.14. This collection is estimated to take 1 hour to complete, including gathering, preparing and submitting the completed application form to the USPTO. Time will vary depending upon the individual case. Any comments on the amount of time you require to complete this form and/or suggestions for reducing this burden, should be sent to the Chief Information Officer, U.S. Patent and Trademark Office, U.S. Department of Commerce, P.O. Box 1450, Alexandria, VA 22313-1450. **DO NOT SEND FEES OR COMPLETED FORMS TO THIS ADDRESS. SEND TO: Commissioner for Patents, P.O. Box 1450, Alexandria, VA 22313-1450.**

## Privacy Act Statement

The Privacy Act of 1974 (P.L. 93-579) requires that you be given certain information in connection with your submission of the attached form related to a patent application or patent. Accordingly, pursuant to the requirements of the Act, please be advised that: (1) the general authority for the collection of this information is 35 U.S.C. 2(b)(2); (2) furnishing of the information solicited is voluntary; and (3) the principal purpose for which the information is used by the U.S. Patent and Trademark Office is to process and/or examine your submission related to a patent application or patent. If you do not furnish the requested information, the U.S. Patent and Trademark Office may not be able to process and/or examine your submission, which may result in termination of proceedings or abandonment of the application or expiration of the patent.

The information provided by you in this form will be subject to the following routine uses:

1. The information on this form will be treated confidentially to the extent allowed under the Freedom of Information Act (5 U.S.C. 552) and the Privacy Act (5 U.S.C. 552a). Records from this system of records may be disclosed to the Department of Justice to determine whether the Freedom of Information Act requires disclosure of these records.
2. A record from this system of records may be disclosed, as a routine use, in the course of presenting evidence to a court, magistrate, or administrative tribunal, including disclosures to opposing counsel in the course of settlement negotiations.
3. A record in this system of records may be disclosed, as a routine use, to a Member of Congress submitting a request involving an individual, to whom the record pertains, when the individual has requested assistance from the Member with respect to the subject matter of the record.
4. A record in this system of records may be disclosed, as a routine use, to a contractor of the Agency having need for the information in order to perform a contract. Recipients of information shall be required to comply with the requirements of the Privacy Act of 1974, as amended, pursuant to 5 U.S.C. 552a(m).
5. A record related to an International Application filed under the Patent Cooperation Treaty in this system of records may be disclosed, as a routine use, to the International Bureau of the World Intellectual Property Organization, pursuant to the Patent Cooperation Treaty.
6. A record in this system of records may be disclosed, as a routine use, to another federal agency for purposes of National Security review (35 U.S.C. 181) and for review pursuant to the Atomic Energy Act (42 U.S.C. 218(c)).
7. A record from this system of records may be disclosed, as a routine use, to the Administrator, General Services, or his/her designee, during an inspection of records conducted by GSA as part of that agency's responsibility to recommend improvements in records management practices and programs, under authority of 44 U.S.C. 2904 and 2906. Such disclosure shall be made in accordance with the GSA regulations governing inspection of records for this purpose, and any other relevant (i.e., GSA or Commerce) directive. Such disclosure shall not be used to make determinations about individuals.
8. A record from this system of records may be disclosed, as a routine use, to the public after either publication of the application pursuant to 35 U.S.C. 122(b) or issuance of a patent pursuant to 35 U.S.C. 151. Further, a record may be disclosed, subject to the limitations of 37 CFR 1.14, as a routine use, to the public if the record was filed in an application which became abandoned or in which the proceedings were terminated and which application is referenced by either a published application, an application open to public inspections or an issued patent.
9. A record from this system of records may be disclosed, as a routine use, to a Federal, State, or local law enforcement agency, if the USPTO becomes aware of a violation or potential violation of law or regulation.

(12) 특허협력조약에 의하여 공개된 국제출원

(19) 세계지식재산권기구  
국제사무국



(10) 국제공개번호  
WO 2012/134085 A2

(43) 국제공개일  
2012년 10월 4일 (04.10.2012)

- (51) 국제특허분류:  
H04N 7/34 (2006.01)
- (21) 국제출원번호: PCT/KR2012/001923
- (22) 국제출원일: 2012년 3월 16일 (16.03.2012)
- (25) 출원언어: 한국어
- (26) 공개언어: 한국어
- (30) 우선권정보:  
10-2011-0030294 2011년 4월 1일 (01.04.2011) KR
- (71) 출원인 (US 을(를) 제외한 모든 지정국에 대하여): 주식회사 아이벡스퍼티홀딩스 (IBEX PT HOLDINGS CO., LTD.) [KR/KR]; 서울특별시 강남구 역삼동 823-26 두산위브센티움 1315 호, 135-080 Seoul (KR).
- (72) 발명자: 김광제
- (75) 발명자/출원인 (US 에 한하여): 김광제 (KIM, Kwangje) [KR/KR]; 서울시 성북구 하월곡동 222 두산아파트 108-501, 136-130 seoul (KR). 오현오 (OH, Hyunoh) [KR/KR]; 경기도 과천시 원문동 래미안슈르 322-1102, 427-739 Gyeonggi do (KR).
- (74) 대리인: 특허법인 로얄 (ROYAL PATENT LAW OFFICE); 서울특별시 관악구 남현동 1059-11 도원회관빌딩 1층, 151-800 Seoul (KR).

- (81) 지정국 (별도의 표시가 없는 한, 가능한 모든 종류의 국내 권리의 보호를 위하여): AE, AG, AL, AM, AO, AT, AU, AZ, BA, BB, BG, BH, BR, BW, BY, BZ, CA, CH, CL, CN, CO, CR, CU, CZ, DE, DK, DM, DO, DZ, EC, EE, EG, ES, FI, GB, GD, GE, GH, GM, GT, HN, HR, HU, ID, IL, IN, IS, JP, KE, KG, KM, KN, KP, KR, KZ, LA, LC, LK, LR, LS, LT, LU, LY, MA, MD, ME, MG, MK, MN, MW, MX, MY, MZ, NA, NG, NI, NO, NZ, OM, PE, PG, PH, PL, PT, QA, RO, RS, RU, RW, SC, SD, SE, SG, SK, SL, SM, ST, SV, SY, TH, TJ, TM, TN, TR, TT, TZ, UA, UG, US, UZ, VC, VN, ZA, ZM, ZW.
- (84) 지정국 (별도의 표시가 없는 한, 가능한 모든 종류의 역내 권리의 보호를 위하여): ARIPO (BW, GH, GM, KE, LR, LS, MW, MZ, NA, RW, SD, SL, SZ, TZ, UG, ZM, ZW), 유라시아 (AM, AZ, BY, KG, KZ, MD, RU, TJ, TM), 유럽 (AL, AT, BE, BG, CH, CY, CZ, DE, DK, EE, ES, FI, FR, GB, GR, HR, HU, IE, IS, IT, LT, LU, LV, MC, MK, MT, NL, NO, PL, PT, RO, RS, SE, SI, SK, SM, TR), OAPI (BF, BJ, CF, CG, CI, CM, GA, GN, GQ, GW, ML, MR, NE, SN, TD, TG).

공개:

- 국제조사보고서 없이 공개하며 보고서 접수 후 이를 별도 공개함 (규칙 48.2(g))

(54) Title: METHOD FOR DECODING IMAGE IN INTRA PREDICTION MODE

(54) 발명의 명칭 : 인트라 예측 모드에서의 영상 복호화 방법

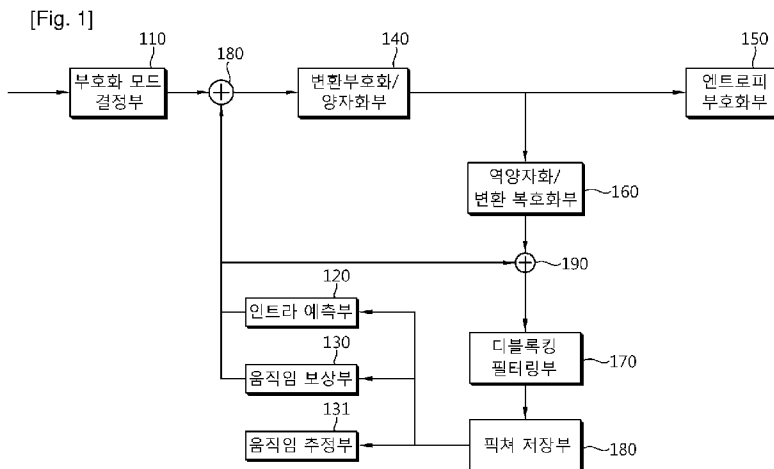

- 110 ... Encoding mode determination unit
- 120 ... Intra prediction unit
- 130 ... Motion compensation unit
- 131 ... Motion estimation unit
- 140 ... Conversion encoding/quantization unit
- 150 ... Entropy encoding unit
- 160 ... Reverse quantization/conversion decoding unit
- 170 ... Deblocking filtering unit
- 180 ... Picture storing unit

(57) Abstract: Disclosed is a method for encoding a video for encoding a video signal at a low data rate while maintaining a high image quality. In order to minimize the number of bits required for a residual block, ineffective reference pixels adjacent to a current block are generated using at least one of restored effective reference pixels adjacent to the current block. In addition, an intra prediction mode of the current block is determined using the effective reference pixels adjacent to the current block of the current block, and filtered reference pixels after the generated reference pixels are filtered. Therefore, generating a reference block most similar to the current block minimizes the volume of data required on the residual block of the current block.

(57) 요약서: 높은 영상 품질을 유지하면서 낮은 데이터 레이트로 동영상 신호를 부호화하기 위한 동영상 부호화 방법이 개시된다. 잔차 블록에 소요되는 비트수를 최소화하기 위해 현재 블록에 인접한 유효하지 않은 참조 화소들을 상기 현재 블록에 인접한 복원된 유효한 적어도 하나 이상의 참조 화소들을 이용하여 생성한다. 또한, 상기 현재 블록의 상기 현재 블록에 인접한 유효한 참조 화소들과, 상기 생성된 참조 화소들을 필터링한 후에 상기 필터링된 참조 화소들을 이용하여 현재 블록의 인트라 예측 모드를 결정한다. 따라서, 현재 블록과 가장 유사한 참조 블록을 생성함으로써, 현재 블록의 잔차 블록에 소요되는 데이터량을 최소화할 수 있는

IPR2021-00827

WO 2012/134085 A2

## 명세서

### 발명의 명칭: 인트라 예측 모드에서의 영상 복호화 방법

#### 기술분야

- [1] 본 발명은 인트라 예측 모드에서의 영상 복호화 방법에 관한 것으로, 더욱 상세하게는 현재 블록의 참조화소들을 적응적으로 생성하고 필터링하여 원본 영상에 가까운 예측 블록을 생성하는 영상 복호화 방법에 관한 것이다.

#### 배경기술

- [2] 높은 영상 품질을 유지하면서 낮은 데이터 레이트로 동영상 신호를 효율적으로 전송하기 위해 다양한 디지털 동영상 압축 기술이 제안되어 왔다. 이러한 동영상 압축 기술로는 H.261, MPEG-2/H.262, H.263, MPEG-4, AVC/H.264등이 있다. 상기한 압축 기술은 이산 코사인 변환(DCT: Discrete Cosine Transform) 기법, 움직임 보상(MC: Motion Compensation) 기법, 양자화(Quantization) 기법, 엔트로피 부호화(Entropy coding) 기법 등을 포함하고 있다.
- [3] 높은 영상 품질을 유지하기 위해서는, 동영상 부호화시 많은 양의 데이터를 요구하게 된다. 그러나, 동영상 데이터를 전달하기 위해 허용되는 대역폭은 한정되어 있어, 부호화 데이터 전송시에 적용할 수 있는 데이터 레이트를 제한할 수 있다. 예를 들어, 위성방송 시스템의 데이터 채널이나 디지털 케이블 텔레비전 네트워크의 데이터 채널은 일반적으로 고정 비트 레이트(CBR: Constant Bit Rate)로 데이터를 보내고 있다.
- [4] 따라서, 동영상 부호화는 되도록이면 처리 방식의 복잡도와 전송 데이터율을 줄이면서도 고화질을 얻도록 하기 위한 동영상 부호화 방식이 제안되고 있다.
- [5] 예를 들어, H.264/AVC 표준은 인트라 부호화시 주변 화소값들을 이용하여 공간영역에서의 인트라 예측 부호화를 수행한다. 주변의 어떤 화소값을 이용할지 결정하는 것이 부호화 효율 향상에 중요한데, 이를 위해 최적의 인트라 예측 방향을 정하고 이 방향에 해당하는 주변 화소값들을 사용하여 부호화할 화소의 예측값을 계산한다.
- [6] 그러나, 예측 블록의 크기가 커지고 다양해지면, 현재 블록에 인접한 참조 블록들의 수가 복수개가 존재할 가능성이 높아지게 된다. 이 경우에는 상기 참조 블록들의 양쪽 경계에 위치하는 참조 화소들 사이에는 단차가 발생할 수 있게 된다. 단차가 발생할 경우, 상기 참조 화소들을 이용하여 인트라 예측을 수행할 경우, 예측 블록 생성 후의 잔차 블록들은 고주파 성분을 많이 함유할 가능성이 높게 되어 부호화 효율을 떨어뜨리게 되는 문제점이 있다.

[7]

#### 발명의 상세한 설명

#### 기술적 과제

- [8] 본 발명이 이루고자 하는 기술적 과제는 원본 영상에 가까운 인트라 예측

블록을 복원하는 방법을 제공하는데 있다. 이에 따라 인트라 예측 모드에서의 복원블록 생성시의 복원해야 할 잔차 신호의 부호화량을 최소화하여 영상의 화질을 높이면서 데이터량을 줄이는 방법을 제공하는데 있다.

### 과제 해결 수단

- [9] 상기 기술적 과제를 해결하기 위한 본 발명의 목적을 달성하기 위한 본 발명에 따른 인트라 예측 모드에서의 영상 복호화 방법은 현재 블록의 인트라 예측 모드를 복원하는 단계, 현재 블록의 이용 가능하지 않은 참조화소가 존재하면, 이용 가능한 참조화소를 이용하여 이용 가능하지 않은 참조화소를 생성하는 단계, 현재 블록의 상기 복원된 인트라 예측 모드 및 현재 블록의 크기에 기초하여 상기 참조화소를 적응적으로 필터링하는 단계, 및 현재 블록의 인트라 예측 모드 및 상기 참조화소 또는 필터링된 참조화소를 이용하여 현재 블록의 예측블록을 생성하는 단계를 포함하고, 상기 이용 가능하지 않은 참조화소의 위치로부터 미리 정해진 방향으로 가장 가까운 위치의 이용 가능한 참조화소의 화소값을 이용 가능하지 않은 참조화소의 화소값으로 설정한다.
- [10] 또한, 상기 기술적 과제를 해결하기 위하여, 본 발명은 상기 이용 가능하지 않은 참조화소의 위치로부터 미리 정해진 방향으로 가장 가까운 위치의 이용 가능한 참조화소가 존재하지 않으면, 반대방향의 가장 가까운 위치의 이용 가능한 참조화소의 화소값을 이용 가능하지 않은 참조화소의 화소값으로 설정한다.
- [11] 또한, 상기 기술적 과제를 해결하기 위하여, 본 발명은 현재 블록의 크기가 커질수록 참조화소를 필터링하는 인트라 예측 모드의 수를 같거나 크게 설정한다.

### 발명의 효과

- [12] 본 발명에 따르면, 이용 가능하지 않은 참조화소를 이용 가능한 참조화소로부터 생성하고, 참조 화소를 현재 블록의 크기 및 인트라 예측 모드에 따라서 적응적으로 필터링한 후에 예측 블록을 생성함으로써, 원본 영상과 유사한 예측 블록을 생성할 수 있는 효과가 있다. 또한, 예측 블록을 원본 영상과 유사하게 예측함으로써, 부호화 및 복호화시의 잔차신호를 최소화하여 영상의 압축성능을 높일 뿐 아니라, 부호화 및 복호화 효율을 극대화할 수 있는 효과가 있다.

### 도면의 간단한 설명

- [13] 도 1은 본 발명의 실시예에 따른 동영상 부호화 장치를 나타내는 블록도이다.
- [14] 도 2는 본 발명의 실시예에 따른 인트라 예측부의 동작을 나타내는 블록도이다.
- [15] 도 3은 본 발명의 실시예에 따른 플래너 모드 예측을 설명하기 위한 도면이다.
- [16] 도 4는 본 발명의 실시예에 따른 동영상 복호화 장치를 나타내는 블록도이다.
- [17] 도 5는 본 발명의 실시예에 따른 인트라 블록을 복원하기 위한 순서도이다.

### 발명의 실시를 위한 최선의 형태

- [18] 이하, 본 발명의 여러가지 실시예들을 예시적인 도면을 통해 상세히 설명한다.

본 발명은 다양한 변경을 가할 수 있고 여러 가지 실시예를 가질 수 있는 바, 본 발명을 특정한 실시 형태에 대해 한정하려는 것이 아니며, 본 발명의 사상 및 기술 범위에 포함되는 모든 변경, 균등물 내지 대체물을 포함하는 것으로 이해되어야 한다. 각 도면을 설명하면서 유사한 참조부호를 유사한 구성요소에 대해 사용하였다.

[19]

[20] 도 1은 본 발명의 실시예에 따른 동영상 부호화 장치를 나타내는 블록도이다.

[21] 도 1를 참조하면, 동영상 부호화 장치는 부호화 모드 결정부(110), 인트라 예측부(120), 움직임 보상부(130), 움직임 추정부(131), 변환부호화/양자화부(140), 엔트로피 부호화부(150), 양자화/변환복호화부(141), 디블록킹 필터링부(160), 픽처 저장부(170), 감산부(180) 및 가산부(190)를 포함한다.

[22] 부호화 모드 결정부(110)는 입력되는 비디오 신호를 분석하여 픽처를 소정 크기의 부호화 블록으로 분할하고, 분할된 소정 크기의 부호화 블록에 대한 부호화 모드를 결정한다. 상기 부호화 모드는 인트라 예측 부호화 및 인터 예측 부호화를 포함한다.

[23] 픽처는 복수의 슬라이스로 구성되고, 슬라이스는 복수개의 최대 부호화 단위(Largest coding unit: LCU)로 구성된다. 상기 LCU는 복수개의 부호화 단위(CU)로 분할될 수 있고, 부호기는 분할여부를 나타내는 정보(flag)를 비트스트림에 추가할 수 있다. 복호기는 LCU의 위치를 어드레스(LcuAddr)를 이용하여 인식할 수 있다. 분할이 허용되지 않는 경우의 부호화 단위(CU)는 예측 단위(Prediction unit: PU)로 간주되고, 복호기는 PU의 위치를 PU 인덱스를 이용하여 인식할 수 있다.

[24] 예측 단위(PU)는 복수개의 파티션으로 나뉠 수 있다. 또한 예측 단위(PU)는 복수개의 변환 단위(Transform unit: TU)로 구성될 수 있다.

[25] 부호화 모드 결정부(110)는 결정된 부호화 모드에 따른 소정 크기의 블록 단위(예를 들면, PU 단위 또는 TU 단위)로 영상 데이터를 감산기(180)로 보낸다.

[26] 변환부호화/양자화부(140)는 감산기(180)에 의해 산출된 잔차 블록을 공간 영역으로부터 주파수 영역으로 변환한다. 예를 들면, 잔차 블록에 대해서 2차원의 이산 코사인 변환(DCT) 또는 이산 사인 변환(DST) 기반의 변환을 실행한다. 또한, 변환부호화/양자화부(140)는 변환 계수를 양자화하기 위한 양자화 스텝 사이즈를 결정하고, 결정된 양자화 스텝 사이즈를 이용하여 변환 계수를 양자화한다. 결정된 양자화 스텝 사이즈 및 부호화 모드에 따라 양자화 매트릭스가 결정될 수 있다.

[27] 양자화된 2차원의 변환 계수는 미리 정해진 스캐닝 방법 중 하나에 의해 1차원의 양자화 변환 계수로 변환된다. 상기 변환된 1차원의 양자화 변환 계수의 시퀀스는 엔트로피 부호화부(150)로 공급된다.

[28] 역양자화/변환복호화부(141)는 변환부호화/양자화부(140)에 의해 양자화된

양자화 계수를 역양자화한다. 또한, 역양자화에 의해 얻어지는 역양자화 계수를 역변환한다. 이에 따라, 주파수 영역으로 변환된 잔차 블록을 공간 영역의 잔차 블록으로 복원할 수 있다.

- [29] 디블록킹 필터링부(160)는 역양자화/역변환부호화부(141)로부터 역양자화 및 역변환된 영상 데이터를 입력 받아 블록킹(blocking) 효과를 제거하기 위한 필터링을 수행한다.
- [30] 픽처 저장부(170)는 필터링된 영상 데이터를 디블록킹 필터링부(160)로부터 입력 받아 픽처(picture) 단위로 영상을 복원하여 저장한다. 픽처는 프레임 단위의 영상이거나 필드 단위의 영상일 수 있다. 픽처 저장부(170)는 다수의 픽처를 저장할 수 있는 버퍼(도시되지 않음)를 구비한다. 버퍼에 저장된 다수의 픽처는 인트라 예측 및 움직임 추정을 위해 제공된다. 인트라 예측 또는 움직임 추정을 위해 제공되는 상기 픽처들은 참조 픽처로 불리운다.
- [31] 움직임 추정부(131)는 상기 픽처 저장부(170)에 저장된 적어도 하나의 참조 픽처를 제공받아 움직임 추정을 수행하여 움직임 벡터, 참조 픽처를 나타내는 인덱스 및 블록 모드를 포함한 모션 데이터(Motion Data)를 출력한다.
- [32] 예측 정밀도를 최적화하기 위해서, 소수 화소 정밀도, 예를 들면, 1/2 또는 1/4 화소 정밀도로 움직임 벡터를 결정한다. 움직임 벡터가 소수 화소 정밀도를 가질 수 있으므로, 움직임 보상부(130)는 소수 화소 위치의 화소값을 산출하기 위한 보간 필터를 참조 픽처에 적용함으로써, 정수 화소 위치의 화소값으로부터 소수 화소 위치의 화소값을 산출한다.
- [33] 움직임 보상부(130)는 움직임 추정부(131)로부터 입력된 모션 데이터에 따라, 픽처 복원부(135)에 저장된 다수의 참조 픽처들 중 움직임 추정에 이용된 참조 픽처로부터, 부호화하고자 하는 블록에 대응하는 예측 블록을 추출하여 출력한다.
- [34] 움직임 보상부(130)는 소수 정밀도의 움직임 보상에 필요한 적응적 보간 필터의 필터 특성을 결정한다. 필터 특성은, 예를 들면, 적응적 보간 필터의 필터 타입을 나타내는 정보, 및, 적응적 보간 필터의 사이즈를 나타내는 정보 등이다. 필터의 사이즈는, 예를 들면, 적응적 보간 필터의 필터 계수의 수인 탭 수 등이다.
- [35] 구체적으로, 움직임 보상부(130)는 적응적 보간 필터로서, 분리형 및 비분리형 적응적 필터 중 어느 하나를 결정할 수 있다. 그리고 나서, 결정된 적응적 보간 필터의 탭 수, 및, 각 필터 계수의 값을 결정한다. 필터 계수의 값은, 정수 화소와의 상대적인 소수 화소의 위치마다 다르게 결정될 수 있다. 또한, 움직임 보상부(160)는, 필터 계수가 고정인 복수개의 비적응적 보간 필터를 이용할 수도 있다.
- [36] 움직임 보상부(130)는, 보간 필터의 특성을 소정의 처리 단위로 설정할 수 있다. 예를 들면, 소수 화소 단위, 부호화 기본 단위(부호화 유닛), 슬라이스 단위, 픽처 단위, 또는, 시퀀스 단위로 설정할 수 있다. 또한, 1개의 영상 데이터에 대해서, 1개의 특성을 설정해도 된다. 따라서, 소정의 처리 단위 내에서는, 동일한 필터

특성을 이용하므로, 움직임 보상부(130)는 필터 특성을 일시적으로 유지하는 메모리를 구비한다. 이 메모리는 필요에 따라, 필터 특성 및 필터 계수 등을 유지한다. 예를 들면, 움직임 보상부(130)는, 1 픽처마다 필터 특성을 결정하고, 슬라이스 단위로 필터 계수를 결정할 수 있다.

- [37] 움직임 보상부(130)는, 픽처 저장부(170)로부터 참조 픽처를 수신하고, 결정된 적응적 보간 필터를 이용하여 필터 처리를 적용함으로써, 소수 정밀도의 예측 참조 화상을 생성한다.
- [38] 그리고, 생성된 참조 화상과, 움직임 추정부(131)에 의해 결정된 움직임 벡터에 의거하여 소수 화소 정밀도의 움직임 보상을 행함으로써, 예측 블록을 생성한다.
- [39] 감산부(180)는 부호화하고자 하는 입력 블록을 픽처 간 예측 부호화하는 경우, 움직임 보상 예측부(137)로부터 입력 블록에 대응하는 참조 픽처 내의 블록을 입력받아 입력 매크로 블록과의 차분 연산을 수행하여 잔차 신호(residue signal)를 출력한다.
- [40] 인트라 예측부(120)는 예측이 수행되는 픽처 내부의 재구성된 화소값을 이용하여 인트라 예측 부호화를 수행한다. 인트라 예측부는 예측 부호화할 현재 블록을 입력 받아 현재 블록의 크기에 따라 미리 설정된 복수개의 인트라 예측 모드 중에 하나를 선택하여 인트라 예측을 수행한다. 인트라 예측부(120)는 현재 블록에 인접한 이전에 부호화된 화소들을 이용해 현재 블록의 인트라 예측 모드를 결정하고, 상기 결정된 모드에 대응하는 예측 블록을 생성한다.
- [41] 현재 픽처에 포함된 영역 중에서 이전에 부호화된 영역은 인트라 예측부(120)가 이용할 수 있도록 다시 복호화되어 픽처 저장부(170)에 저장되어 있다. 인트라 예측부(120)는 픽처 저장부(170)에 저장되어 있는 현재 픽처의 이전에 부호화된 영역에서 현재 블록에 인접한 화소 또는 인접하지 않지만 적용 가능한 화소들을 이용하여 현재 블록의 예측 블록을 생성한다.
- [42] 인트라 예측부(120)는 인트라 블록을 예측하기 위하여 인접 화소를 적응적으로 필터링할 수 있다. 복호기에서의 동일한 동작을 위해 부호기에서 필터링 여부를 알려주는 정보를 전송할 수 있다. 또는 현재 블록의 인트라 예측 모드 및 현재 블록의 크기 정보에 기초하여 필터링 여부를 결정할 수 있다.
- [43] 영상 부호화 장치에 의해 사용되는 예측 타입은 상기 부호화 모드 결정부에 의해 입력 블록이 인트라 모드 또는 인터 모드로 부호화되는지 여부에 의존한다.
- [44] 인트라 모드와 인터 모드의 전환은, 인트라/인터 전환 스위치에 의해 제어된다.
- [45] 엔트로피 부호화부(150)는 변환/양자화부(140)에 의해 양자화된 양자화 계수와 움직임 추정부(131)에 의해 생성된 움직임 정보를 엔트로피 부호화한다. 또한, 인트라 예측 모드, 제어 데이터(예를 들면, 양자화 스텝 사이즈 등) 등도 부호화될 수 있다. 또한, 움직임 보상부(130)에 의해 결정된 필터 계수도 부호화되어 비트 스트림으로서 출력한다.
- [46]
- [47] 도 2는 본 발명에 따른 인트라 예측부(120)의 동작을 나타내는 블록도이다.



- [48] 먼저, 부호화 모드 결정부(110)에 의해 예측 모드 정보 및 예측 블록의 크기를 수신한다(S110). 예측 모드 정보는 인트라 모드를 나타낸다. 예측 블록의 크기는 64x64, 32x32, 16x16, 8x8, 4x4 등의 정방형일 수 있으나, 이에 한정하지 않는다. 즉, 상기 예측 블록의 크기가 정방형이 아닌 비정방형일 수도 있다.
- [49] 다음으로, 예측 블록의 인트라 예측 모드를 결정하기 위해 참조 화소를 픽처 저장부(170)로부터 읽어 들인다. 상기 이용 가능하지 않은 참조 화소가 존재하는지 여부를 검토하여 참조 화소 생성 여부를 판단한다(S120). 상기 참조 화소들은 현재 블록의 인트라 예측 모드를 결정하는데 사용된다.
- [50] 현재 블록이 현재 픽처의 상측 경계에 위치하는 경우에는 현재 블록의 상측에 인접한 화소들이 정의되지 않는다. 또한, 현재 블록이 현재 픽처의 좌측 경계에 위치하는 경우에는 현재 블록의 좌측에 인접한 화소들이 정의되지 않는다. 이러한 화소들은 이용 가능한 화소들이 아닌 것으로 판단한다. 또한, 현재 블록이 슬라이스 경계에 위치하여 슬라이스의 상측 또는 좌측에 인접하는 화소들이 먼저 부호화되어 복원되는 화소들이 아닌 경우에도 이용 가능한 화소들이 아닌 것으로 판단한다.
- [51] 상기와 같이 현재 블록의 좌측 또는 상측에 인접한 화소들이 존재하지 않거나, 미리 부호화되어 복원된 화소들이 존재하지 않는 경우에는 이용 가능한 화소들만을 이용하여 현재 블록의 인트라 예측 모드를 결정할 수도 있다.
- [52] 그러나, 현재 블록의 이용 가능한 참조 화소들을 이용하여 이용 가능하지 않은 위치의 참조 화소들을 생성할 수도 있다(S130). 예를 들어, 상측 블록의 화소들이 이용 가능하지 않은 경우에는 좌측 화소들의 일부 또는 전부를 이용하여 상측 화소들을 생성할 수 있고, 그 역으로도 가능하다. 즉, 이용 가능하지 않은 위치의 참조 화소로부터 미리 정해진 방향으로 가장 가까운 위치의 이용 가능한 참조 화소를 복사하여 참조 화소로 생성할 수 있다. 미리 정해진 방향에 이용 가능한 참조 화소가 존재하지 않는 경우에는 반대 방향의 가장 가까운 위치의 이용 가능한 참조 화소를 복사하여 참조 화소로 생성할 수 있다.
- [53] 한편, 현재 블록의 상측 또는 좌측 화소들이 존재하는 경우에도 상기 화소들이 속하는 블록의 부호화 모드에 따라 이용 가능하지 않은 참조 화소로 결정될 수 있다. 예를 들어, 현재 블록의 상측에 인접한 참조 화소가 속하는 블록이 인트라 부호화되어 복원된 블록일 경우에는 상기 화소들을 이용 가능하지 않은 화소들로 판단할 수 있다. 이 경우에는 현재 블록에 인접한 블록이 인트라 부호화되어 복원된 블록에 속하는 화소들을 이용하여 이용 가능한 참조 화소들을 생성할 수 있다. 이 경우에는 부호기에서 부호화 모드에 따라 이용 가능한 참조 화소를 판단한다는 정보를 복호기로 전송해야 한다.
- [54] 다음으로, 상기 참조 화소들을 이용하여 현재 블록의 인트라 예측 모드를 결정한다(S140). 현재 블록에 허용 가능한 인트라 예측 모드의 수는 블록의 크기에 따라 달라질 수 있다. 예를 들어, 현재 블록의 크기가 8x8, 16x16, 32x32인 경우에는 34개의 인트라 예측 모드가 존재할 수 있고, 현재 블록의 크기가 4x4인

경우에는 17개의 인트라 예측 모드가 존재할 수 있다. 상기 34개 또는 17개의 인트라 예측 모드는 적어도 하나 이상의 비방향성 모드(non-directional mode)와 복수개의 방향성 모드들(directional modes)로 구성될 수 있다. 하나 이상의 비방향성 모드는 DC 모드 및/또는 플래너(planar) 모드일 수 있다. DC 모드 및 플래너모드가 비방향성 모드로 포함되는 경우에는, 현재 블록의 크기에 관계없이 35개의 인트라 예측 모드가 존재할 수도 있다. 이때에는 2개의 비방향성 모드(DC 모드 및 플래너 모드)와 33개의 방향성 모드를 포함할 수 있다.

- [55] 플래너 모드는 현재 블록의 우하측(bottom-right)에 위치하는 적어도 하나의 화소값(또는 상기 화소값의 예측값, 이하 제1 참조값이라 함)과 참조화소들을 이용하여 현재 블록의 예측 블록을 생성한다.
- [56] 도 3을 참조하여 플래너 모드를 설명한다. 도 3은 현재 블록이 8x8 블록일 경우의 플래너 모드 예측을 설명하기 위한 도면이다.
- [57] 현재 블록의 우하측(bottom-right)에 위치하는 제 1 참조값(D)과 현재 블록의 좌측에 인접하는 현재 블록의 가장 아래쪽 화소에 인접하는 화소값(C)을 이용하여 그 사이에 위치하는 화소들에 대응하는 예측 화소들을 생성한다. 마찬가지로 상기 제1참조값(D)과 현재 블록의 상측에 인접하는 화소들 중 현재 블록의 가장 우측의 화소와 인접하는 화소값(B)을 이용하여 그 사이에 위치하는 화소들에 대응하는 예측 화소들을 생성한다. 상기 예측 화소를 생성하기 위해서 선형결합을 사용할 수 있다. 그러나, 화소들의 배치가 선형이 아닌 경우에는 미리 정해진 비선형 결합으로 상기 예측 화소들을 생성할 수 있다.
- [58] 다음으로, 생성된 예측 화소들(즉, 화소 C와 D 사이의 화소들 및 화소 B와 D 사이의 화소들)과 현재 블록에 인접한 화소들(즉, A와 B 사이의 화소들 및 A와 C 사이의 화소들)을 이용하여 나머지 예측 화소들을 생성한다. 상기 예측 화소들은 상측 및 좌측에 인접한 2개의 화소 및 하측 및 우측에 생성된 2개의 화소들을 선형결합하여 생성할 수 있다. 또한, 상기 결합은 반드시 선형일 필요는 없으며, 화소들의 분포를 고려한 비선형 결합일 수도 있다. 이와 같이, 플래너 모드에서는 예측 화소를 생성하기 위해 사용되는 참조화소들의 수가 예측 화소의 위치에 따라 달라질 수 있다.
- [59] 한편, 현재 블록의 좌측 참조화소들은 이용 가능하나, 상측 참조화소들이 이용 가능하지 않는 경우가 발생할 수 있다. 이때에는, 상기 제1 참조값 또는 상기 좌측 참조화소들 중 하나를 이용하여 상기 상측 참조화소들을 생성할 수 있다. 즉, 좌측 참조화소들만 이용 가능할 경우에는 좌측 참조화소들 중 최상측에 위치한 참조화소를 복사하여 상측 참조화소들을 생성할 수 있고, 상기 제1 참조값과 상기 상측 화소에 가장 근접한 위치에 있는 참조화소를 이용하여 B와 D 사이의 예측화소들을 생성할 수 있다.
- [60] 마찬가지로, 현재 블록의 상측 참조화소들은 이용 가능하나, 좌측 참조화소들이 이용 가능하지 않은 경우에는 상기 상측 참조화소들 중 최좌측에

- 위치한 참조화소를 복사하여 좌측 참조화소를 생성할 수 있고, 상기 좌측 참조화소와 제1 참조값을 이용하여 C와 D 사이의 예측화소들을 생성할 수 있다.
- [61] 한편, 상기 제1 참조값 또는 이를 나타내는 정보는 비트스트림에 추가되어 복호기로 전송되거나, 복호기가 상기 제1 참조값을 유도할 수도 있다.
- [62] 상기 제1 참조값 또는 이를 나타내는 정보를 복호기로 전송하는 방법을 사용할 경우에는 현재 블록에 인접한 부호화되어 복원된 화소들 중 적어도 하나 이상을 이용한 제1 참조값의 예측값과 상기 제1 참조값과의 차이값을 전송하는 것이 비트수를 줄일 수 있다. 이를 위해 상기 제1 참조값의 예측값은 (1) 현재 블록에 인접한 참조 화소들의 평균값, (2) A, B, C의 평균값, (3) B와 C의 평균값 중 어느 하나일 수 있다. 또 다른 방법으로는, A와 C의 차이값과 A와 B의 차이값을 비교하여 차이값이 작은 방향을 나타내는 어느 하나(B또는 C)로 결정할 수도 있다.
- [63] 상기 제1 참조값을 부호기와 복호기가 유도할 경우에는 부호기와 복호기가 동일한 참조값을 유도할 수 있어야 한다. 이를 위해 부호기에서는 제1 참조값을 생성하기 위해 참조 화소 A, B, C를 이용할 수 있다. 화면이 평탄하게 변한다는 가정 하에서는 (1) B와 A의 차이값을 C에 더한 값 또는 C와 A의 차이값을 B에 더한 값, 즉  $(B+C-A)$ , (2) B와 C의 평균값 중 어느 하나를 제1 참조값으로 설정할 수 있다. 이 경우, B, C 대신에 B의 인접 참조화소 및 C의 인접 참조화소를 이용할 수도 있다. 이와 같이, 부호기와 복호기가 동일하게 제1 참조값을 복원할 수 있으므로, 제1 참조값 또는 이를 나타내는 정보를 복호기로 전송할 필요가 없어 전송 비트 수를 줄일 수 있다.
- [64]
- [65] 다음으로, 현재 블록의 인트라 예측 모드가 결정되면, 예측 블록을 생성한다(S150). 상기 예측 블록은 현재 블록의 인트라 예측 모드에 기초하여 참조 화소(생성된 화소 포함) 또는 이들의 선형결합을 이용하여 생성한다. DC 모드는 현재 블록에 인접한 참조 화소들의 평균값을 이용하여 현재 블록의 예측 블록을 생성한다. 상기 참조화소들은 이용 가능한 참조화소 및 생성된 참조화소를 모두 포함할 수 있다.
- [66] 다음으로, 현재 블록의 인트라 예측 모드가 결정되면 상기 인트라 예측 모드를 부호화한다(S160). 상기 인트라 예측 모드의 부호화는 인트라 예측부(120)에서 행해질 수도 있고, 별도의 인트라 예측 모드 부호화 장치(미도시) 또는 엔트로피 부호화부(150)에서 행해질 수도 있다.
- [67] 한편, 현재 블록에 인접한 참조 블록들의 수가 다양한 경우에는 상기 참조 블록들의 경계에 위치하는 참조 화소들 간에 단차가 발생할 수 있다. 이 경우, 예측 블록 생성 후의 잔차 블록들은 고주파 성분을 많이 함유할 가능성이 높게 된다. 따라서, 참조 블록들 사이의 블록킹 아티팩트(blocking artifact)가 현재의 블록에도 영향을 미치는 문제가 발생한다. 이러한 문제점은 현재 블록의 크기가 클수록 빈도수가 높아지게 된다. 반대로, 참조 블록의 사이즈가 현재 블록의

사이즈보다 클 경우에는 이러한 문제가 발생하지 않을 수 있다.

- [68] 따라서, 상기의 문제점을 극복하기 위한 하나의 방법은 상기 참조 화소들을 적응적으로 필터링하여 새로운 참조 화소들을 생성하는 것이다. 이는 인트라 예측 모드를 결정하기 전에 수행할 수도 있다. 인트라 예측 모드 및 예측 블록의 크기에 따라 미리 상기 참조 화소들을 적응적으로 필터링하여 새로운 참조 화소들을 생성하고, 원래의 참조 화소 및 상기 생성된 새로운 참조 화소들을 이용하여 현재 블록의 인트라 예측 모드를 결정할 수도 있다. 그러나, 현재 블록의 인트라 예측 모드를 결정한 후에 상기 방법을 수행할 수도 있다. 블록킹 아티팩트의 문제는 블록의 크기가 커질수록 커지므로, 특정 크기의 블록의 범위에서는 블록의 크기가 커질수록 참조 화소를 필터링하는 예측모드의 수를 같거나 크게 할 수 있다.
- [69] 상기 이용 가능한 참조 화소의 필터링이 필요한 경우에는, 상기한 참조 화소들 간의 단차의 차이 정도에 따라 2개 이상의 필터를 적응적으로 적용할 수도 있다. 상기 필터는 저역 통과 필터인 것이 바람직하다. 예를 들어, 2개의 필터를 이용할 경우, 제1 필터는 3-tap 필터, 제2 필터는 5-tap 필터일 수 있다. 제2 필터는 제1 필터를 2번 적용하는 필터일 수도 있다. 상기 필터의 필터계수는 대칭적인 것이 바람직하다. 또는 복잡도 감소를 위해 1개의 필터만을 사용할 수도 있다.
- [70] 또한, 상기한 필터가 현재 블록(인트라 예측이 수행될 블록)의 크기에 따라 적응적으로 적용되는 것이 바람직하다. 즉, 필터를 적용할 경우, 현재 블록의 크기가 제1 크기보다 작을 경우에는 대역폭이 좁은 필터를 적용하거나 필터를 적용하지 않을 수 있으며, 제1 크기~제2 크기의 현재 블록에 대해서는 필터를 적용하는 인트라 예측 모드의 수를 증가시키는 것이 바람직하다. 상기 인트라 예측이 수행될 현재 블록은 변환블록의 크기일 수 있다.
- [71] DC 모드의 경우에는 참조 화소들의 평균값으로 예측 블록이 생성되므로, 필터를 적용할 필요가 없다. 즉, 필터를 적용할 경우 불필요한 연산량만이 많아지게 된다. 또한, 영상이 수직 방향으로 연관성(correlation)이 있는 수직 모드에서는 참조 화소에 필터를 적용할 필요가 없다. 영상이 수평 방향으로 연관성이 있는 수평 모드에서도 참조 화소에 필터를 적용할 필요가 없다. 이와 같이, 필터링의 적용 여부는 현재 블록의 인트라 예측 모드와도 연관성이 있으므로, 현재 블록의 인트라 예측 모드 및 인트라 예측이 수행될 블록의 크기에 기초하여 참조 화소를 적응적으로 필터링할 수 있다. 인트라 예측이 수행될 블록의 크기가 미리 정해진 크기(예를 들어, 4x4)보다 작은 경우에는 참조 화소를 필터링하지 않는다. 또는 복잡도 감소를 위해 미리 정해진 크기보다 큰 경우에도 참조 화소를 필터링하지 않을 수도 있다. 상기 블록의 크기가 미리 정해진 크기 범위 내에 속하는 경우에는, 대각선 방향의 인트라 예측 모드(수평 또는 수직 모드와 45도 각도의 방향성을 갖는 모드)와 수평 방향의 인트라 예측 모드 사이의 인트라 예측 모드들 중 어느 하나의 모드에서 참조 화소가 필터링되면, 상기 모드와 대각선 방향의 인트라 예측 모드 사이의 방향성

모드들에서는 참조화소를 필터링한다.

[72]

[73] 상기의 문제점을 극복하기 위한 또 다른 방법은 상기 참조 화소들을 이용하여 생성된 예측 블록의 일부 화소들을 적응적으로 필터링하여 새로운 예측 블록을 생성하는 것이다. 현재 블록의 인트라 예측 모드에 따라 예측 블록의 예측 화소들 중 참조화소들과 접하는 예측 화소들을 적어도 하나 이상의 참조 화소들을 이용하여 보정할 수 있다. 이는 예측 블록 생성시에 함께 적용될 수도 있다.

[74] 예를 들어, DC 모드에서는 예측 화소들 중 참조화소들과 접하는 예측 화소는 상기 예측 화소와 접하는 참조화소를 이용하여 필터링한다. 따라서, 예측 화소의 위치에 따라 1개 또는 2개의 참조화소를 이용하여 예측 화소를 필터링한다. DC 모드에서의 예측화소의 필터링은 모든 크기의 예측 블록에 적용할 수 있다.

[75] 수직 모드에서는 예측 블록의 예측 화소들 중 좌측 참조화소와 접하는 예측화소들은 상기 예측블록을 생성하는데 이용되는 상측화소 이외의 참조화소들을 이용하여 변경될 수 있다. 마찬가지로, 수평 모드에서는 생성된 예측 화소들 중 상측 참조화소와 접하는 예측화소들은 상기 예측블록을 생성하는데 이용되는 좌측화소 이외의 참조화소들을 이용하여 변경될 수 있다.

[76]

[77] 한편, 현재 블록과 상기 인트라 예측부(120)에 의해 생성된 예측 블록의 잔차 블록은 변환부호화/양자화부(140) 및 엔트로피 부호화부(150)를 통해 부호화된다.

[78] 상기 잔차 블록은 먼저 변환 부호화된다. 효과적인 에너지 압축을 위해, 상기 잔차 블록에 적용할 변환 부호화를 위한 변환 블록의 크기를 먼저 결정하고, 결정된 크기의 블록 단위로 변환 부호화한다. 또는 변환 변환의 크기는 미리 결정되어 있을 수도 있다. 이 경우, 인트라 예측을 수행하는 현재 블록의 크기가 변환블록의 크기일 수도 있다. 인트라 예측 모드 값에 따라 서로 다른 변환 부호화 방식이 적용될 수 있다. 예를 들어, DC mode로 인트라 예측된 잔차 블록에 대해서는 수평 및 수직방향으로 정수기반 DCT(Discrete cosinetransform)를, planar mode에 대해서는 수평 및 수직 방향으로 정수기반 DST(Discrete sine transform)을 적용할 수도 있다. 이는 소정크기보다 작거나 같은 블록에 대해서 적용할 수 있다. 그러나, 소정 크기보다 큰 변환블록에 대해서는 인트라 예측 모드에 관계없이 정수기반 DCT만을 적용할 수도 있다. 수평 및 수직 방향 DCT 방식과 DST 방식이 예측 모드에 따라 적응적으로 적용될 수도 있다.

[79] 다음으로, 변환 부호화된 잔차 블록이 양자화한다. 잔차 블록의 크기에 따라 서로 다른 양자화 매트릭스가 적용된다. 또한, 동일한 크기의 잔차 블록의 경우에도 서로 다른 양자화 매트릭스가 적용될 수 있다. 즉, 변환 부호화된 잔차 블록의 계수들의 분포에 기초하여 적어도 2개 이상의 양자화 매트릭스 중 가장

- 효과적인 양자화 매트릭스를 적용할 수 있다. 이 경우에는 상기 양자화 매트릭스를 나타내는 정보를 복호기로 전송한다. 또한, 인트라 예측 모드에 따라 서로 다른 양자화 매트릭스를 변환 부호화된 잔차 블록에 적용할 수도 있다.
- [80] 다음으로, 상기 2차원의 양자화된 계수들을 미리 정해진 복수개의 스캔 패턴 중 하나를 선택하여 1차원의 양자화 계수 시퀀스로 변경한 후에 엔트로피 부호화한다. 상기 스캔 패턴은 인트라 예측 모드에 따라 결정될 수도 있고, 인트라 예측 모드와 변환블록의 크기에 따라 결정될 수도 있다.
- [81]
- [82] 도 4는 본 발명의 실시예에 따른 동영상 복호화 장치를 나타내는 블록도이다.
- [83] 도 4를 참조하면, 본 발명에 따른 동영상 복호화 장치는, 엔트로피 복호부(210), 역양자화/역변환부(220), 가산기(270), 더블록킹 필터부(250), 픽처 저장부(260), 인트라 예측부(230), 움직임 보상 예측부(240) 및 인트라/인터전환 스위치(280)를 구비한다.
- [84] 엔트로피 복호부(210)는, 동영상 부호화 장치로부터 전송되는 부호화 비트스트림을 복호하여, 인트라 예측 모드 인덱스, 움직임 정보, 양자화 계수 시퀀스 등으로 분리한다. 엔트로피 복호부(210)는 복호된 움직임 정보를 움직임 보상 예측부(240)에 공급한다. 엔트로피 복호부(210)는 상기 인트라 예측 모드 인덱스를 상기 인트라 예측부(230), 역양자화/역변환부(220)로 공급한다. 또한, 상기 엔트로피
- [85] 복호화(210)는 상기 역양자화 계수 시퀀스를 역양자화/역변환부(220)로 공급한다.
- [86] 역양자화/역변환부(220)는 상기 양자화 계수 시퀀스를 2차원 배열의 역양자화 계수로 변환한다. 상기 변환을 위해 복수개의 스캐닝 패턴 중에 하나를 선택한다. 현재 블록의 예측모드(즉, 인트라 예측 및 인터 예측 중의 어느 하나)와 인트라 예측 모드 및 변환 블록의 크기에 기초하여 복수개의 스캐닝 패턴 중 하나를 선택한다. 상기 인트라 예측 모드는 인트라 예측부 또는 엔트로피 복호화부로부터 수신한다.
- [87] 역양자화/역변환부(220)는 상기 2차원 배열의 역양자화 계수에 복수개의 양자화 매트릭스 중 선택된 양자화 매트릭스를 이용하여 양자화 계수를 복원한다. 상기 양자화 매트릭스는 부호기로부터 수신된 정보를 이용하여 결정될 수도 있다. 복원하고자 하는 현재 블록(변환 블록)의 크기에 따라 서로 다른 양자화 매트릭스가 적용되며, 동일 크기의 블록에 대해서도 상기 현재 블록의 예측 모드 및 인트라 예측 모드 중 적어도 하나에 기초하여 양자화 매트릭스를 선택할 수 있다. 그리고, 상기 복원된 양자화 계수를 역변환하여 잔차 블록을 복원한다.
- [88] 가산기(270)는 역양자화/역변환부(220)에 의해 복원된 잔차 블록과 인트라 예측부(230) 또는 움직임 보상 예측부(240)에 의해 생성되는 예측 블록을 가산함으로써, 영상 블록을 복원한다.

- [89] 디블록킹 필터(250)는 가산기(270)에 의해 생성된 복원 영상에 디블록킹 필터 처리를 실행한다. 이에 따라, 양자화 과정에 따른 영상 손실에 기인하는 디블록킹 아티팩트를 줄일 수 있다.
- [90] 픽처 저장부(260)는 디블록킹 필터(250)에 의해 디블록킹 필터 처리가 실행된 로컬 복호 영상을 유지하는 프레임 메모리이다.
- [91] 인트라 예측부(230)는 엔트로피 복호화부(210)로부터 수신된 인트라 예측 모드 인덱스에 기초하여 현재 블록의 인트라 예측 모드를 복원한다. 그리고, 복원된 인트라 예측 모드에 따라 예측 블록을 생성한다.
- [92] 움직임 보상 예측부(240)는 움직임 벡터 정보에 기초하여 픽처 저장부(240)에 저장된 픽처로부터 현재 블록에 대한 예측 블록을 생성한다. 소수 정밀도의 움직임 보상이 적용될 경우에는 선택된 보간 필터를 적용하여 예측 블록을 생성한다.
- [93] 인트라/인터 전환 스위치(280)는 부호화 모드에 기초하여 인트라 예측부(250)와 움직임 보상 예측부(260)의 어느 하나에서 생성된 예측 블록을 가산기(235)에 제공한다.
- [94]
- [95] 이하, 상기도 4를 참조하여, 현재 블록을 인트라 예측을 통해 복원하는 과정을 설명한다. 도 5는 본 발명의 실시예에 따른 인트라 블록을 복원하기 위한 순서도이다.
- [96] 먼저, 수신된 비트스트림으로부터 현재 블록의 인트라 예측 모드를 복호한다(S310).
- [97] 이를 위해, 엔트로피 복호부(210)는 복수개의 인트라 예측 모드 테이블 중 하나를 참조하여 현재 블록의 제1 인트라 예측 모드 인덱스를 복원한다.
- [98] 상기 복수개의 인트라 예측 모드 테이블은 부호기와 복호기가 공유하는 테이블로서, 현재 블록에 인접한 복수개의 블록들의 인트라 예측 모드의 분포에 따라 선택된 어느 하나의 테이블이 적용될 수 있다. 일례로써, 현재 블록의 좌측 블록의 인트라 예측 모드와 현재 블록의 상측 블록의 인트라 예측 모드가 동일하면 제1 인트라 예측 모드 테이블을 적용하여 현재 블록의 제1 인트라 예측 모드 인덱스를 복원하고, 동일하지 않으면 제2 인트라 예측 모드 테이블을 적용하여 현재 블록의 제1 인트라 예측 모드 인덱스를 복원할 수 있다. 또 다른 예로써, 현재 블록의 상측 블록과 좌측 블록의 인트라 예측 모드가 모두 방향성 예측 모드(directional intra prediction mode)일 경우에는, 상기 상측 블록의 인트라 예측 모드의 방향과 상기 좌측 블록의 인트라 예측 모드의 방향이 소정 각도 이내이면, 제1 인트라 예측 모드 테이블을 적용하여 현재 블록의 제1 인트라 예측 모드 인덱스를 복원하고, 소정 각도를 벗어나면 제2 인트라 예측 모드 테이블을 적용하여 현재 블록의 제1 인트라 예측 모드 인덱스를 복원할 수도 있다.
- [99] 엔트로피 복호부(210)는 복원된 현재 블록의 제1 인트라 예측 모드 인덱스를

인트라 예측부(230)로 전송한다. 상기 제1 인트라 예측 모드를 인덱스를 수신한 인트라 예측부(230)는 상기 인덱스가 최소값을 가질 경우(즉, 0)에는 현재 블록의 최대가능모드를 현재 블록의 인트라 예측 모드로 결정한다. 그러나, 상기 인덱스가 0 이외의 값을 가질 경우에는 현재 블록의 최대가능모드가 나타내는 인덱스와 상기 제1 인트라 예측 모드 인덱스를 비교한다. 비교 결과, 상기 제1 인트라 예측 모드 인덱스가 상기 현재 블록의 최대가능모드가 나타내는 인덱스보다 작지 않으면, 상기 제1 인트라 예측 모드 인덱스에 1을 더한 제2 인트라 예측 모드 인덱스에 대응하는 인트라 예측 모드를 현재 블록의 인트라 예측 모드로 결정하고, 그렇지 않으면 상기 제1 인트라 예측 모드 인덱스에 대응하는 인트라 예측 모드를 현재 블록의 인트라 예측 모드를 결정한다.

- [100] 현재 블록에 허용 가능한 인트라 예측 모드는 적어도 하나 이상의 비방향성 모드(non-directional mode)와 복수개의 방향성 모드들(directional modes)로 구성될 수 있다. 하나 이상의 비방향성 모드는 DC 모드 및/또는 플래너(planar) 모드일 수 있다. 또한, DC 모드와 플래너 모드 중 어느 하나가 적응적으로 상기 허용 가능한 인트라 예측 모드 셋에 포함될 수 있다. 이를 위해, 픽처 헤더 또는 슬라이스 헤더에 상기 허용 가능한 인트라 예측 모드 셋에 포함되는 비방향성 모드를 특징하는 정보가 포함될 수 있다.
- [101] 다음으로, 인트라 예측부(230)는 인트라 예측 블록을 생성하기 위해, 참조 화소들을 픽처 저장부(260)로부터 읽어 들이고, 이용 가능하지 않은 참조 화소가 존재하는지 여부를 판단한다(S320). 상기 판단은 현재 블록의 복호된 인트라 예측 모드를 적용하여 인트라 예측 블록을 생성하는데 이용되는 참조 화소들의 존재 여부에 따라 행해질 수도 있다.
- [102] 다음으로, 인트라 예측부(230)는 참조 화소를 생성할 필요가 있을 경우에는 미리 복원된 이용 가능한 참조 화소들을 이용하여 이용 가능하지 않은 위치의 참조 화소들을 생성한다(S325). 이용 가능하지 않은 참조 화소에 대한 정의 및 참조 화소의 생성 방법은 도 2에 따른 인트라 예측부(120)에서의 동작과 동일하다. 다만, 현재 블록의 복호된 인트라 예측 모드에 따라 인트라 예측 블록을 생성하는데 이용되는 참조 화소만들을 선택적으로 복원할 수도 있다.
- [103] 다음으로, 인트라 예측부(230)는 예측 블록을 생성하기 위하여, 참조 화소들에 필터를 적용할지 여부를 판단한다(S330). 즉, 인트라 예측부(230)는 현재 블록의 인트라 예측 블록을 생성하기 위하여 참조 화소들에 대해 필터링을 적용할지 여부를 상기 복호된 인트라 예측 모드 및 현재 예측 블록의 크기에 기초하여 결정한다. 블록킹 아티팩트의 문제는 블록의 크기가 커질수록 커지므로, 블록의 크기가 커질수록 참조 화소를 필터링하는 예측모드의 수를 증가시킬 수 있다. 그러나, 블록이 소정 크기보다 커지는 경우에는 평탄한 영역으로 볼 수 있으므로 복잡도 감소를 위해 참조 화소를 필터링하지 않을 수 있다.
- [104] 상기 참조 화소에 필터 적용이 필요하다고 판단된 경우에는 필터를 이용하여 상기 참조 화소들을 필터링한다(S335).



- [105] 상기한 참조 화소들 간의 단차의 차이 정도에 따라 적어도 2개 이상의 필터를 적응적으로 적용할 수도 있다. 상기 필터의 필터계수는 대칭적인 것이 바람직하다.
- [106] 또한, 상기한 2개 이상의 필터가 현재 블록의 크기에 따라 적응적으로 적용될 수도 있다. 즉, 필터를 적용할 경우, 크기가 작은 블록에 대해서는 대역폭이 좁은 필터를, 크기가 큰 블록들에 대해서는 대역폭이 넓은 필터를 적용할 수도 있다.
- [107] DC 모드 경우에는 참조 화소들의 평균값으로 예측 블록이 생성되므로, 필터를 적용할 필요가 없다. 즉, 필터를 적용할 경우 불필요한 연산량만이 많아지게 된다. 또한, 영상이 수직 방향으로 연관성(correlation)이 있는 수직 모드에서는 참조화소에 필터를 적용할 필요가 없다. 영상이 수평 방향으로 연관성이 있는 수평 모드에서도 참조화소에 필터를 적용할 필요가 없다. 이와 같이, 필터링의 적용 여부는 현재 블록의 인트라 예측 모드와도 연관성이 있으므로, 현재 블록의 인트라 예측 모드 및 예측 블록의 크기에 기초하여 참조화소를 적응적으로 필터링할 수 있다.
- [108] 다음으로, 상기 복원된 인트라 예측 모드에 따라, 상기 참조 화소 또는 상기 필터링된 참조 화소들을 이용하여 예측 블록을 생성한다(S340). 상기 예측 블록의 생성은 도 2의 부호기에서의 동작과 동일하므로 생략한다. 플래너 모드의 경우에도 도 2의 부호기에서의 동작과 동일하므로 생략한다.
- [109]
- [110] 다음으로, 상기 생성된 예측 블록을 필터링할지 여부를 판단한다(S350). 상기 필터링 여부의 판단은 슬라이스 헤더 또는 부호화 유닛 헤더에 포함된 정보를 이용할 수 있다. 또한, 현재 블록의 인트라 예측 모드에 따라 결정될 수도 있다.
- [111] 상기 생성된 예측 블록을 필터링할 것으로 판단할 경우, 생성된 예측 블록을 필터링한다(S335). 구체적으로, 현재 블록에 인접한 이용 가능한 참조 화소들을 이용하여 생성된 예측 블록의 특정 위치의 화소를 필터링하여 새로운 화소를 생성한다. 이는 예측 블록 생성시에 함께 적용될 수도 있다. 예를 들어, DC 모드에서는 예측 화소들 중 참조화소들과 접하는 예측 화소는 상기 예측 화소와 접하는 참조화소를 이용하여 필터링한다. 따라서, 예측 화소의 위치에 따라 1개 또는 2개의 참조화소를 이용하여 예측 화소를 필터링한다. DC 모드에서의 예측화소의 필터링은 모든 크기의 예측 블록에 적용할 수 있다. 수직 모드에서는 예측 블록의 예측 화소들 중 좌측 참조화소와 접하는 예측화소들은 상기 예측블록을 생성하는데 이용되는 상측화소 이외의 참조화소들을 이용하여 변경될 수 있다. 마찬가지로, 수평 모드에서는 생성된 예측 화소들 중 상측 참조화소와 접하는 예측화소들은 상기 예측블록을 생성하는데 이용되는 좌측화소 이외의 참조화소들을 이용하여 변경될 수 있다.
- [112]
- [113] 이와 같은 방식으로 복원된 현재 블록의 예측 블록과 복호화한 현재 블록의 잔차 블록을 이용하여 현재 블록이 복원된다.

[114]

[115]     상기에서는 본 발명의 바람직한 실시예를 참조하여 설명하였지만, 해당 기술 분야의 숙련된 당업자는 하기의 특허 청구의 범위에 기재된 본 발명의 사상 및 영역으로부터 벗어나지 않는 범위 내에서 본 발명을 다양하게 수정 및 변경시킬 수 있음을 이해할 수 있을 것이다.

[116]

## 청구범위

- [청구항 1] 인트라 예측 모드에서의 영상 복호화 방법에 있어서,  
 현재 블록의 인트라 예측 모드를 복원하는 단계;  
 현재 블록의 이용 가능하지 않은 참조화소가 존재하면, 이용 가능한 참조화소를 이용하여 참조화소를 생성하는 단계;  
 현재 블록의 상기 복원된 인트라 예측 모드 및 현재 블록의 크기에 기초하여 상기 참조화소를 적응적으로 필터링하는 단계; 및  
 현재 블록의 인트라 예측 모드 및 상기 참조화소를 이용하여 현재 블록의 예측블록을 생성하는 단계를 포함하고,  
 상기 참조화소를 생성하는 단계는 상기 이용 가능하지 않은 참조화소의 위치로부터 미리 정해진 방향으로 가장 가까운 위치의 이용 가능한 참조화소의 화소값을 이용 가능하지 않은 참조화소의 화소값으로 설정하는 것을 특징으로 하는 영상 복호화 방법.
- [청구항 2] 상기 제1항에 있어서, 상기 이용 가능하지 않은 참조화소의 위치로부터 미리 정해진 방향으로 이용 가능한 참조화소가 존재하지 않으면, 반대 방향의 가장 가까운 위치의 이용 가능한 참조화소의 화소값을 이용 가능하지 않은 참조화소의 화소값으로 설정하는 것을 특징으로 하는 영상 복호화 방법.
- [청구항 3] 제1항에 있어서, 현재 블록의 잔차 블록을 역양자화하고 역변환하는 과정을 더 포함하고, 상기 역양자화를 위하여 부호기로부터 수신된 정보에 따라 결정되는 양자화 매트릭스를 이용하여 상기 잔차블록을 역양자화하는 것을 특징으로 하는 영상 복호화 방법.
- [청구항 4] 제1항에 있어서, 상기 참조화소를 적응적으로 필터링하는 단계는 현재 블록의 인트라 예측모드가 수평 또는 수직 모드이면, 참조화소를 필터링하지 않는 것을 특징으로 하는 영상 복호화 방법.
- [청구항 5] 제1항에 있어서, 수평 모드와 대각선 방향의 인트라 예측 모드 사이의 특정 방향을 갖는 인트라 예측 모드에서 참조화소가 필터링되면, 상기 특정 방향의 인트라 예측 모드와 상기 대각선 방향의 인트라 예측 모드 사이의 방향성 모드에서는 참조화소를 필터링하는 것을 특징으로 하는 영상 복호화 방법.
- [청구항 6] 제1항에 있어서, 현재 블록의 인트라 예측모드가 수직 모드이면, 예측 블록의 좌측 경계 예측 화소들은 예측 블록 생성에 이용되는 상측 화소 이외의 참조화소들을 이용하여 변경되는 것을 특징으로 하는 영상 복호화 방법.
- [청구항 7] 제1항에 있어서, 현재 블록의 인트라 예측 모드가 플래너

모드이면, 현재 블록의 제1 참조값, 현재 블록의 우상측 코너 참조 화소와 접하는 참조화소 및 현재 블록의 좌하측 코너화소와 접하는 참조화소를 이용하여 예측 블록의 우측 경계 및 아래쪽 경계에 위치하는 예측화소를 생성하는 것을 특징으로 하는 영상 복호화 방법.

[청구항 8]

제7항에 있어서, 상기 제1 참조값은 현재 블록의 2개의 미리 정해진 위치의 화소의 화소값의 평균값을 이용하여 생성하는 것을 특징으로 하는 영상 복호화 방법.

[청구항 9]

제1항에 있어서, 현재 블록의 예측 모드가 DC 모드이면, 현재 블록의 크기에 관계없이 예측 블록의 예측 화소들 중 참조화소들과 접하는 예측 화소들을 상기 적어도 하나 이상의 참조화소들을 이용하여 필터링하는 것을 특징으로 하는 영상 복호화 방법.

[Fig. 1]

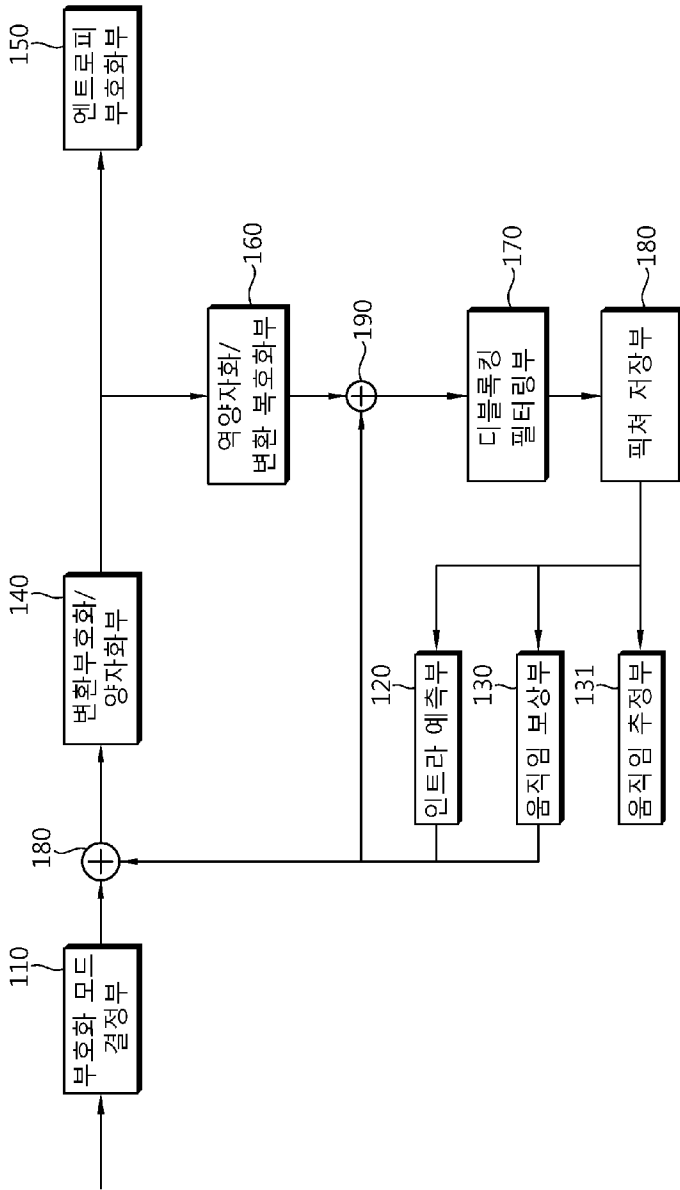

[Fig. 2]

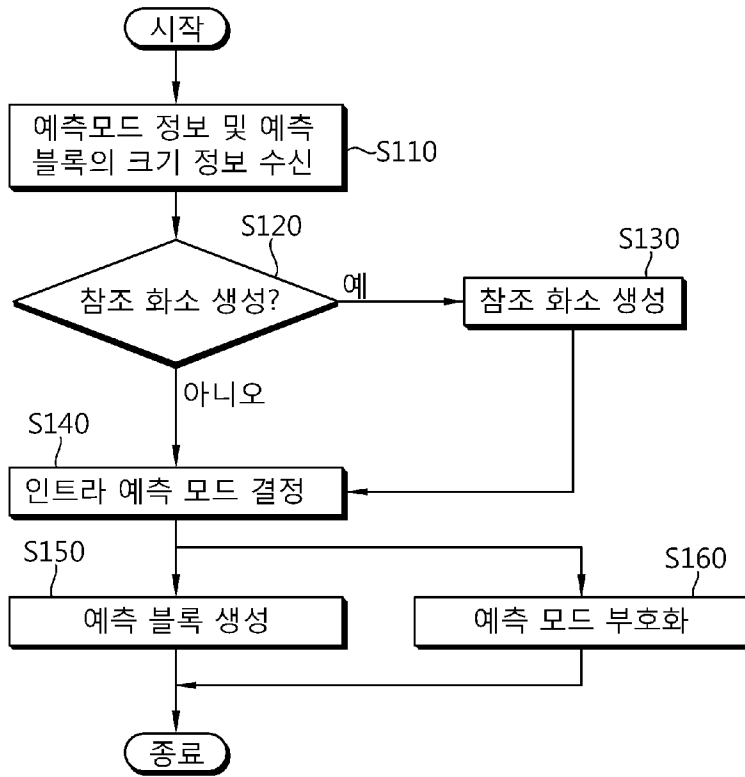

[Fig. 3]

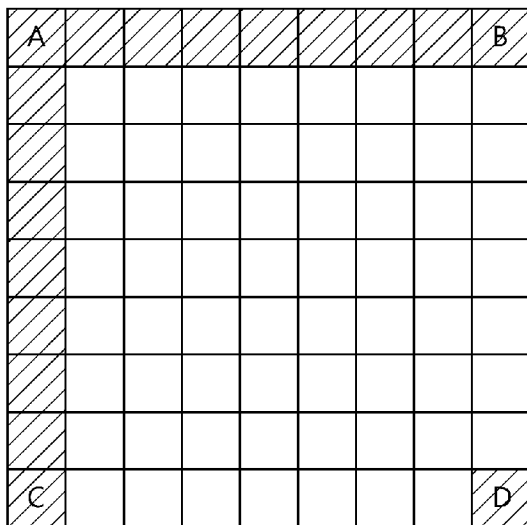

[Fig. 4]

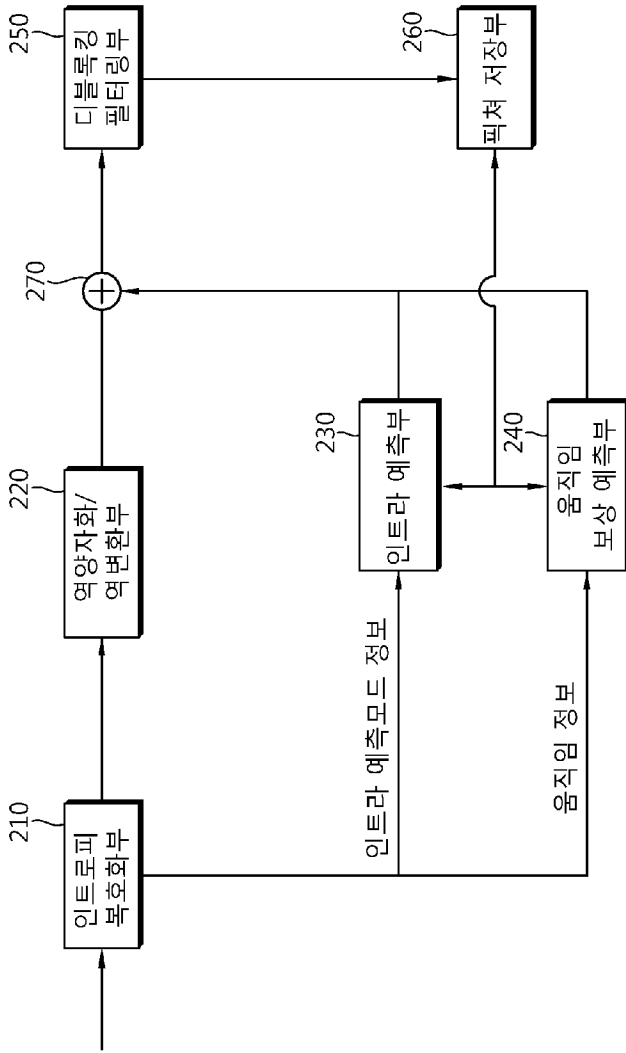

[Fig. 5]

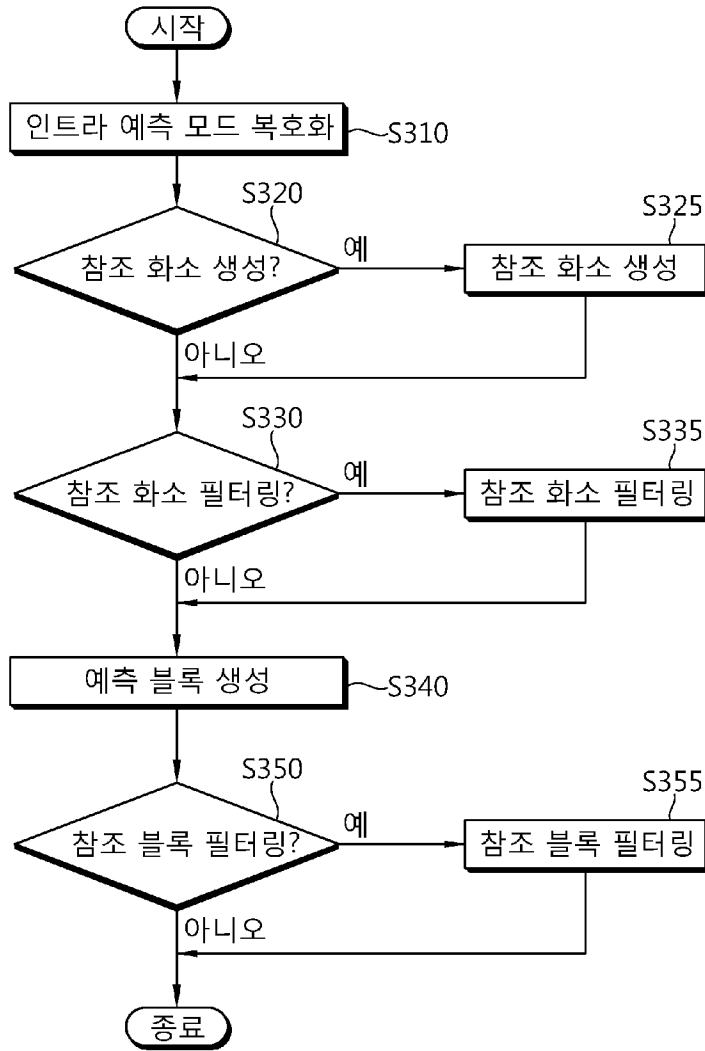



(12) 특허협력조약에 의하여 공개된 국제출원

(19) 세계지식재산권기구  
국제사무국



(10) 국제공개번호  
WO 2012/134085 A3

(43) 국제공개일  
2012년 10월 4일 (04.10.2012)

- (51) 국제특허분류: H04N 7/34 (2006.01)
- (21) 국제출원번호: PCT/KR2012/001923
- (22) 국제출원일: 2012년 3월 16일 (16.03.2012)
- (25) 출원언어: 한국어
- (26) 공개언어: 한국어
- (30) 우선권정보: 10-2011-0030294 2011년 4월 1일 (01.04.2011) KR
- (71) 출원인 (US 을(를) 제외한 모든 지정국에 대하여): 주식회사 아이벡스퍼티홀딩스 (IBEX PT HOLDINGS CO., LTD.) [KR/KR]; 135-080 서울특별시 강남구 역삼동 823-26 두산위브센티움 1315 호, Seoul (KR).
- (72) 발명자: 김광제
- (75) 발명자/출원인 (US 에 한하여): 김광제 (KIM, Kwangje) [KR/KR]; 136-130 서울시 성북구 하월곡동 222 두산아파트 108-501, seoul (KR). 오현오 (OH, Hyunoh) [KR/KR]; 427-739 경기도 과천시 원문동 래미안슈르 322-1102, Gyeonggi do (KR).
- (74) 대리인: 특허법인 로얄 (ROYAL PATENT LAW OFFICE); 151-800 서울특별시 관악구 남현동 1059-11 동원회관빌딩 1층, Seoul (KR).

- (81) 지정국 (별도의 표시가 없는 한, 가능한 모든 종류의 국내 권리의 보호를 위하여): AE, AG, AL, AM, AO, AT, AU, AZ, BA, BB, BG, BH, BR, BW, BY, BZ, CA, CH, CL, CN, CO, CR, CU, CZ, DE, DK, DM, DO, DZ, EC, EE, EG, ES, FI, GB, GD, GE, GH, GM, GT, HN, HR, HU, ID, IL, IN, IS, JP, KE, KG, KM, KN, KP, KR, KZ, LA, LC, LK, LR, LS, LT, LU, LY, MA, MD, ME, MG, MK, MN, MW, MX, MY, MZ, NA, NG, NI, NO, NZ, OM, PE, PG, PH, PL, PT, QA, RO, RS, RU, RW, SC, SD, SE, SG, SK, SL, SM, ST, SV, SY, TH, TJ, TM, TN, TR, TT, TZ, UA, UG, US, UZ, VC, VN, ZA, ZM, ZW.
- (84) 지정국 (별도의 표시가 없는 한, 가능한 모든 종류의 역내 권리의 보호를 위하여): ARIPO (BW, GH, GM, KE, LR, LS, MW, MZ, NA, RW, SD, SL, SZ, TZ, UG, ZM, ZW), 유라시아 (AM, AZ, BY, KG, KZ, MD, RU, TJ, TM), 유럽 (AL, AT, BE, BG, CH, CY, CZ, DE, DK, EE, ES, FI, FR, GB, GR, HR, HU, IE, IS, IT, LT, LU, LV, MC, MK, MT, NL, NO, PL, PT, RO, RS, SE, SI, SK, SM, TR), OAPI (BF, BJ, CF, CG, CI, CM, GA, GN, GQ, GW, ML, MR, NE, SN, TD, TG).

공개:

- 국제조사보고서와 함께 (조약 제 21 조(3))
- (88) 국제조사보고서 공개일: 2013년 1월 3일

(54) Title: METHOD FOR DECODING IMAGE IN INTRA PREDICTION MODE

(54) 발명의 명칭: 인트라 예측 모드에서의 영상 복호화 방법

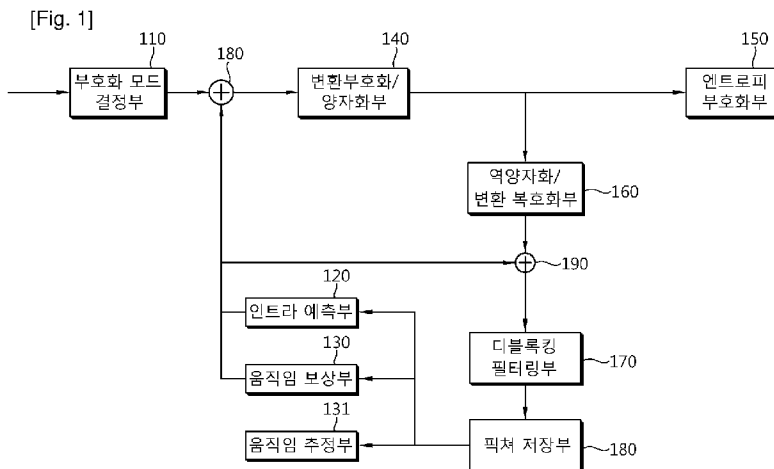

- 110 ... Encoding mode determination unit
- 120 ... Intra prediction unit
- 130 ... Motion compensation unit
- 131 ... Motion estimation unit
- 140 ... Conversion encoding/quantization unit
- 150 ... Entropy encoding unit
- 160 ... Reverse quantization/conversion decoding unit
- 170 ... Deblocking filtering unit
- 180 ... Picture storing unit

(57) Abstract: Disclosed is a method for encoding a video for encoding a video signal at a low data rate while maintaining a high image quality. In order to minimize the number of bits required for a residual block, ineffective reference pixels adjacent to a current block are generated using at least one of restored effective reference pixels adjacent to the current block. In addition, an intra prediction mode of the current block is determined using the effective reference pixels adjacent to the current block of the current block, and filtered reference pixels after the generated reference pixels are filtered. Therefore, generating a reference block most similar to the current block minimizes the volume of data required on the residual block of the current block.

(57) 요약서: 높은 영상 품질을 유지하면서 낮은 데이터 레이트로 동영상 신호를 부호화하기 위한 동영상 부호화 방법이 개시된다. 잔차 블록에 소요되는 비트수를 최소화하기 위해 현재 블록에 인접한 유효하지 않은 참조 화소들을 상기 현재 블록에 인접한 복원된 유효한 적어도 하나 이상의 참조 화소들을 이용하여 생성한다. 또한, 상기 현재 블록의 상기 현재 블록에 인접한 유효한 참조 화소들과, 상기 생성된 참조 화소들을 필터링한 후에 상기 필터링된 참조 화소들을 이용하여 현재 블록의 인트라 예측 모드를 결정한다. 따라서, 현재 블록과 가장 유사한 참조 블록을 생성함으로써, 현재 블록의 잔차 블록에 소요되는 데이터량을 최소화할 수 있는

WO 2012/134085 A3

IPR2021-00827

## A. CLASSIFICATION OF SUBJECT MATTER

**H04N 7/34(2006.01)i**

According to International Patent Classification (IPC) or to both national classification and IPC

## B. FIELDS SEARCHED

Minimum documentation searched (classification system followed by classification symbols)

H04N 7/34; H04N 7/24; H04N 7/32; H04N 7/26

Documentation searched other than minimum documentation to the extent that such documents are included in the fields searched  
 Korean Utility models and applications for Utility models: IPC as above  
 Japanese Utility models and applications for Utility models: IPC as above

Electronic data base consulted during the international search (name of data base and, where practicable, search terms used)

eKOMPASS (KIPO internal) &amp; Keywords: "intra prediction, filtering"

## C. DOCUMENTS CONSIDERED TO BE RELEVANT

Category*	Citation of document, with indication, where appropriate, of the relevant passages	Relevant to claim No.
A	KR 10-2011-0018189 A (SAMSUNG ELECTRONICS CO., LTD.) 23 February 2011 See abstract, figure 2, page 5, [0034]-[0042] and claim 1.	1-9
A	KR 10-2010-0132973 A (THOMSON LICENSING) 20 December 2010 See abstract, page 14, [0121]-[0131] and claim 1.	1-9
A	EP 2293567 A2 (SAMSUNG ELECTRONICS CO., LTD.) 09 March 2011 See abstract and figure 1.	1-9

 Further documents are listed in the continuation of Box C.
  See patent family annex.

\* Special categories of cited documents:

"A" document defining the general state of the art which is not considered to be of particular relevance

"E" earlier application or patent but published on or after the international filing date

"L" document which may throw doubts on priority claim(s) or which is cited to establish the publication date of another citation or other special reason (as specified)

"O" document referring to an oral disclosure, use, exhibition or other means

"P" document published prior to the international filing date but later than the priority date claimed

"T" later document published after the international filing date or priority date and not in conflict with the application but cited to understand the principle or theory underlying the invention

"X" document of particular relevance; the claimed invention cannot be considered novel or cannot be considered to involve an inventive step when the document is taken alone

"Y" document of particular relevance; the claimed invention cannot be considered to involve an inventive step when the document is combined with one or more other such documents, such combination being obvious to a person skilled in the art

"&amp;" document member of the same patent family

Date of the actual completion of the international search

08 OCTOBER 2012 (08.10.2012)

Date of mailing of the international search report

08 OCTOBER 2012 (08.10.2012)

Name and mailing address of the ISA/KR

 Korean Intellectual Property Office  
 Government Complex-Daejeon, 139 Seonsa-ro, Daejeon 302-701,  
 Republic of Korea

Facsimile No. 82-42-472-7140

Authorized officer

Telephone No.

IPR2021-00827

Patent document cited in search report	Publication date	Patent family member	Publication date
KR 10-2011-0018189 A	23.02.2011	CA 2768694 A1	24.02.2011
		CN 102484719 A	30.05.2012
		EP 2454883 A2	23.05.2012
		US 2011-0038415 A1	17.02.2011
		US 2012-0140824 A1	07.06.2012
		WO 2011-021839 A2	24.02.2011
KR 10-2010-0132973 A	20.12.2010	CN 102090062 A	08.06.2011
		EP 2263381 A1	22.12.2010
		JP 2011-517230 A	26.05.2011
		WO 2009-126299 A1	15.10.2009
EP 2293567 A2	09.03.2011	AU 2009-258401 A1	17.12.2009
		CN 102124739 A	13.07.2011
		JP 2011-523321 A	04.08.2011
		KR 10-2009-0129926 A	17.12.2009
		US 2011-0090967 A1	21.04.2011
		WO 2009-151232 A2	17.12.2009

**A. 발명이 속하는 기술분류(국제특허분류(IPC))**  
  
**H04N 7/34(2006.01)i**

**B. 조사된 분야**

조사된 최소문헌(국제특허분류를 기재)  
H04N 7/34; H04N 7/24; H04N 7/32; H04N 7/26

조사된 기술분야에 속하는 최소문헌 이외의 문헌  
한국등록실용신안공보 및 한국공개실용신안공보: 조사된 최소문헌란에 기재된 IPC  
일본등록실용신안공보 및 일본공개실용신안공보: 조사된 최소문헌란에 기재된 IPC

국제조사에 이용된 전산 데이터베이스(데이터베이스의 명칭 및 검색어(해당하는 경우))  
eKOMPASS(특허청 내부 검색시스템) & 키워드: "인트라 예측, 필터링"

**C. 관련 문헌**

카테고리*	인용문헌명 및 관련 구절(해당하는 경우)의 기재	관련 청구항
A	KR 10-2011-0018189 A (삼성전자주식회사) 2011.02.23 요약, 도면2, 페이지5, [0034]-[0042] 및 청구항1.	1-9
A	KR 10-2010-0132973 A (툼슨 라이선싱) 2010.12.20 요약, 페이지14, [0121]-[0131] 및 청구항1.	1-9
A	EP 2293567 A2 (SAMSUNG ELECTRONICS CO., LTD.) 2011.03.09 요약 및 도면1.	1-9

추가 문헌이 C(계속)에 기재되어 있습니다.  대응특허에 관한 별지를 참조하십시오.

\* 인용된 문헌의 특별 카테고리:  
 "A" 특별히 관련이 없는 것으로 보이는 일반적인 기술수준을 정의한 문헌  
 "E" 국제출원일보다 빠른 출원일 또는 우선일을 가지나 국제출원일 이후에 공개된 선출원 또는 특허 문헌  
 "L" 우선권 주장에 의문을 제기하는 문헌 또는 다른 인용문헌의 공개일 또는 다른 특별한 이유(이유를 명시)를 밝히기 위하여 인용된 문헌  
 "O" 구두 개시, 사용, 전시 또는 기타 수단을 언급하고 있는 문헌  
 "P" 우선일 이후에 공개되었으나 국제출원일 이전에 공개된 문헌  
 "T" 국제출원일 또는 우선일 후에 공개된 문헌으로, 출원과 상충하지 않으며 발명의 기초가 되는 원리나 이론을 이해하기 위해 인용된 문헌  
 "X" 특별한 관련이 있는 문헌. 해당 문헌 하나만으로 청구된 발명의 신규성 또는 진보성이 없는 것으로 본다.  
 "Y" 특별한 관련이 있는 문헌. 해당 문헌이 하나 이상의 다른 문헌과 조합하는 경우로 그 조합이 당업자에게 자명한 경우 청구된 발명은 진보성이 없는 것으로 본다.  
 "&" 동일한 대응특허문헌에 속하는 문헌

국제조사의 실제 완료일 2012년 10월 08일 (08.10.2012)	국제조사보고서 발송일 <b>2012년 10월 08일 (08.10.2012)</b>
--	--

ISA/KR의 명칭 및 우편주소 대한민국 특허청 (302-701) 대전광역시 서구 청사로 189, 4동 (둔산동, 정부대전청사) 팩스 번호 82-42-472-7140	심사관 김영태 전화번호 82-42-481-8367	IPR2021-00827
--	-----------------------------------	---------------

국제조사보고서에서 인용된 특허문헌	공개일	대응특허문헌	공개일
KR 10-2011-0018189 A	2011.02.23	CA 2768694 A1 CN 102484719 A EP 2454883 A2 US 2011-0038415 A1 US 2012-0140824 A1 WO 2011-021839 A2	2011.02.24 2012.05.30 2012.05.23 2011.02.17 2012.06.07 2011.02.24
KR 10-2010-0132973 A	2010.12.20	CN 102090062 A EP 2263381 A1 JP 2011-517230 A WO 2009-126299 A1	2011.06.08 2010.12.22 2011.05.26 2009.10.15
EP 2293567 A2	2011.03.09	AU 2009-258401 A1 CN 102124739 A JP 2011-523321 A KR 10-2009-0129926 A US 2011-0090967 A1 WO 2009-151232 A2	2009.12.17 2011.07.13 2011.08.04 2009.12.17 2011.04.21 2009.12.17

(19) 日本国特許庁(JP)

(12) 公表特許公報(A)

(11) 特許出願公表番号

特表2014-512129  
(P2014-512129A)

(43) 公表日 平成26年5月19日(2014.5.19)

(51) Int. Cl. F I テーマコード (参考)  
H04N 19/50 (2014.01) H04N 7/137 Z 5C159

審査請求 未請求 予備審査請求 未請求 (全 21 頁)

(21) 出願番号	特願2014-502448 (P2014-502448)	(71) 出願人	513244041 アイベックス・ビイティ・ホールディング ス・カンパニー・リミテッド 大韓民国・135-080・ソウル・カン ナム・グ・イエオクサム・ドン・823- 26・ドゥーサン ウィヴ センティウム ・ナンバー1315
(86) (22) 出願日	平成24年3月16日 (2012.3.16)	(74) 代理人	100064621 弁理士 山川 政樹
(85) 翻訳文提出日	平成25年11月6日 (2013.11.6)	(74) 代理人	100098394 弁理士 山川 茂樹
(86) 国際出願番号	PCT/KR2012/001923		
(87) 国際公開番号	W02012/134085		
(87) 国際公開日	平成24年10月4日 (2012.10.4)		
(31) 優先権主張番号	10-2011-0030294		
(32) 優先日	平成23年4月1日 (2011.4.1)		
(33) 優先権主張国	韓国 (KR)		

最終頁に続く

(54) 【発明の名称】 イントラ予測モードにおける映像復号化方法

(57) 【要約】

高い映像品質を維持しつつ、低いデータレートで動画像信号を符号化するための動画像符号化方法が開始される。残差ブロックにかかるビット数を最小化するために、現在ブロックに隣接した有効でない参照画素を前記現在ブロックに隣接した、復元された有効な少なくとも1つ以上の参照画素を用いて生成する。また、前記現在ブロックに隣接した有効な参照画素と、前記生成された参照画素をフィルタリングした後、前記フィルタリングされた参照画素を用いて現在ブロックのイントラ予測モードを決定する。したがって、現在ブロックと最も類似した参照ブロックを生成することにより、現在ブロックの残差ブロックにかかるデータ量を最小化できるという効果がある。

【選択図】 図1

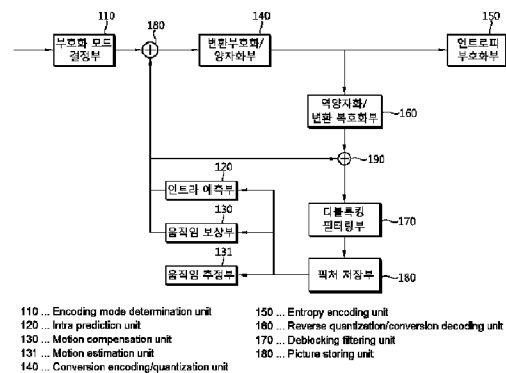

## 【特許請求の範囲】

## 【請求項 1】

イントラ予測モードにおける映像復号化方法であって、  
 現在ブロックのイントラ予測モードを復元するステップと、  
 現在ブロックの利用可能でない参照画素が存在すれば、利用可能な参照画素を用いて参照画素を生成するステップと、

現在ブロックの前記復元されたイントラ予測モード及び現在ブロックのサイズに基づいて、前記参照画素を適応的にフィルタリングするステップと、

現在ブロックのイントラ予測モード及び前記参照画素を用いて現在ブロックの予測ブロックを生成するステップと、

を含み、

前記参照画素を生成するステップは、前記利用可能でない参照画素の位置から予め決められた方向に最も近い位置の利用可能な参照画素の画素値を利用可能でない参照画素の画素値として設定することを特徴とする映像復号化方法。

## 【請求項 2】

前記利用可能でない参照画素の位置から予め決められた方向に利用可能な参照画素が存在しなければ、反対方向の最も近い位置の利用可能な参照画素の画素値を利用可能でない参照画素の画素値として設定することを特徴とする請求項 1 に記載の映像復号化方法。

## 【請求項 3】

現在ブロックの残差ブロックを逆量子化し、逆変換する過程をさらに含み、前記逆量子化のために、符号器から受信された情報により決定される量子化マトリックスを用いて前記残差ブロックを逆量子化することを特徴とする請求項 1 に記載の映像復号化方法。

## 【請求項 4】

前記参照画素を適応的にフィルタリングするステップは、現在ブロックのイントラ予測モードが水平または垂直モードであれば、参照画素をフィルタリングしないことを特徴とする請求項 1 に記載の映像復号化方法。

## 【請求項 5】

水平モードと対角線方向のイントラ予測モード間の特定方向を有するイントラ予測モードで参照画素がフィルタリングされれば、前記特定方向のイントラ予測モードと前記対角線方向のイントラ予測モードとの間の方向性モードでは、参照画素をフィルタリングすることを特徴とする請求項 1 に記載の映像復号化方法。

## 【請求項 6】

現在ブロックのイントラ予測モードが垂直モードであれば、予測ブロックの左側境界予測画素は、予測ブロック生成に用いられる上側画素以外の参照画素を用いて変更されることを特徴とする請求項 1 に記載の映像復号化方法。

## 【請求項 7】

現在ブロックのイントラ予測モードがプラナーモードであれば、現在ブロックの第 1 の参照値、現在ブロックの右上側コーナ参照画素と接する参照画素、及び現在ブロックの左下側コーナ画素と接する参照画素を用いて予測ブロックの右側境界及び下側境界に位置する予測画素を生成することを特徴とする請求項 1 に記載の映像復号化方法。

## 【請求項 8】

前記第 1 の参照値は、現在ブロックの 2 個の予め決められた位置の画素の画素値の平均値を用いて生成することを特徴とする請求項 7 に記載の映像復号化方法。

## 【請求項 9】

現在ブロックの予測モードが DC モードであれば、現在ブロックのサイズに関係なく、予測ブロックの予測画素のうち、参照画素と接する予測画素を前記少なくとも 1 つ以上の参照画素を用いてフィルタリングすることを特徴とする請求項 1 に記載の映像復号化方法。

## 【発明の詳細な説明】

## 【技術分野】

10

20

30

40

50

## 【0001】

本発明は、イントラ予測モードにおける映像復号化方法に関し、より詳細には、現在ブロックの参照画素を適応的に生成し、フィルタリングして原本映像に近い予測ブロックを生成する映像復号化方法に関する。

## 【背景技術】

## 【0002】

高い映像品質を維持しつつ、低いデータレートで動画像信号を効率的に伝送するために、様々なデジタル動画像圧縮技術が提案されてきた。このような動画像圧縮技術としては、H. 261、MPEG-2/H. 262、H. 263、MPEG-4、AVC/H. 264などがある。前記した圧縮技術は、離散コサイン変換(DCT: Discrete Cosine Transform)技法、動き補償(MC: Motion Compensation)技法、量子化(Quantization)技法、エントロピー符号化(Entropy coding)技法などを含んでいる。

10

## 【0003】

高い映像品質を維持するためには、動画像符号化の際に、多くの量のデータを求めるようになる。しかし、動画像データを伝達するために許容される帯域幅は限定されており、符号化データの伝送時に適用できるデータレートを制限することができる。例えば、衛星放送システムのデータチャネルやデジタルケーブルテレビジョンネットワークのデータチャネルは、一般に固定ビットレート(CBR: Constant Bit Rate)でデータを送っている。

20

## 【0004】

したがって、動画像符号化は、なるべく処理方式の複雑度と伝送データ率を減らしながらも、高画質を得るようにするための動画像符号化方式が提案されている。

## 【0005】

例えば、H. 264/AVC標準は、イントラ符号化の際に、周辺画素値を用いて空間領域におけるイントラ予測符号化を行う。周辺のある画素値を用いるのか決定することが符号化効率の向上に重要であるが、このために、最適のイントラ予測方向を決め、この方向に該当する周辺画素値を用いて符号化する画素の予測値を計算する。

## 【0006】

しかし、予測ブロックのサイズが大きくなり多様化すれば、現在ブロックに隣接した参照ブロックの数が複数個存在する可能性が高まるようになる。この場合には、前記参照ブロックの両方境界に位置する参照画素間には段差が発生できるようになる。段差が生じ、前記参照画素を用いてイントラ予測を行う場合、予測ブロック生成後の残差ブロックは、高周波成分を多く含有する可能性が高くなり、符号化効率を低下させるという問題がある。

30

## 【発明の概要】

## 【発明が解決しようとする課題】

## 【0007】

本発明が解決しようとする技術的課題は、原本映像に近いイントラ予測ブロックを復元する方法を提供することにある。これにより、イントラ予測モードにおける復元ブロック生成時の復元すべき残差信号の符号化量を最小化して映像の画質を高めながら、データ量を減らす方法を提供することにある。

40

## 【課題を解決するための手段】

## 【0008】

上記技術的課題を解決し、本発明の目的を達成するための本発明に係るイントラ予測モードにおける映像復号化方法は、現在ブロックのイントラ予測モードを復元するステップと、現在ブロックの利用可能でない参照画素が存在すれば、利用可能な参照画素を用いて利用可能でない参照画素を生成するステップと、現在ブロックの前記復元されたイントラ予測モード及び現在ブロックのサイズに基づいて、前記参照画素を適応的にフィルタリングするステップと、現在ブロックのイントラ予測モード及び前記参照画素またはフィルタ

50



リングされた参照画素を用いて現在ブロックの予測ブロックを生成するステップとを含み、前記利用可能でない参照画素の位置から予め決められた方向に最も近い位置の利用可能な参照画素の画素値を利用可能でない参照画素の画素値として設定する。

【0009】

また、上記技術的課題を解決するために、本発明は、前記利用可能でない参照画素の位置から予め決められた方向に最も近い位置の利用可能な参照画素が存在しなければ、反対方向の最も近い位置の利用可能な参照画素の画素値を利用可能でない参照画素の画素値として設定する。

【0010】

また、上記技術的課題を解決するために、本発明は、現在ブロックのサイズが大きくなるほど、参照画素をフィルタリングするイントラ予測モードの数を同じであるか、大きく設定する。

【発明の効果】

【0011】

本発明によれば、利用可能でない参照画素を利用可能な参照画素から生成し、参照画素を現在ブロックのサイズ及びイントラ予測モードにしたがって適応的にフィルタリングした後、予測ブロックを生成することにより、原本映像と類似した予測ブロックを生成できるという効果がある。また、予測ブロックを原本映像と類似して予測することにより、符号化及び復号化時の残差信号を最小化して映像の圧縮性能を高めるだけでなく、符号化及び復号化の効率を極大化することができるという効果がある。

【図面の簡単な説明】

【0012】

【図1】図1は、本発明の実施形態に係る動画像符号化装置を示したブロック図である。

【0013】

【図2】図2は、本発明の実施形態に係るイントラ予測部の動作を示したブロック図である。

【0014】

【図3】図3は、本発明の実施形態に係るプラナーモード予測を説明するための図である。

【0015】

【図4】図4は、本発明の実施形態に係る動画像復号化装置を示したブロック図である。

【0016】

【図5】図5は、本発明の実施形態に係るイントラブロックを復元するための順序図である。

【発明を実施するための形態】

【0017】

以下、本発明の様々な実施形態を例示的な図面を介して詳細に説明する。本発明は、様々な変更を加えることができ、様々な実施形態を有することができる。本発明を特定の実施形態に対して限定しようとするものではなく、本発明の思想及び技術範囲に含まれる全ての変更、均等物ないし代替物を含むものと理解されなければならない。各図面を説明しながら、類似した参照符号を類似した構成要素に対して使用した。

【0018】

図1は、本発明の実施形態に係る動画像符号化装置を示したブロック図である。

【0019】

図1に示すように、動画像符号化装置は、符号化モード決定部110、イントラ予測部120、動き補償部130、動き推定部131、変換符号化・量子化部140、エントロピー符号化部150、逆量子化・変換復号化部141、デブロッキングフィルタリング部160、ピクチャー保存部170、減算部180、及び加算部190を備える。

【0020】

符号化モード決定部110は、入力されるビデオ信号を分析してピクチャーを所定サイ

ズの符号化ブロックに分割し、分割された所定サイズの符号化ブロックに対する符号化モードを決定する。前記符号化モードは、イントラ予測符号化及びインター予測符号化を含む。

#### 【0021】

ピクチャーは、複数のスライスで構成され、スライスは、複数個の最大符号化単位（Largest coding unit：LCU）で構成される。前記LCUは、複数個の符号化単位（CU）に分割されることができ、符号器は、分割可否を表す情報（flag）をビットストリームに追加することができる。復号器は、LCUの位置をアドレス（LcuAddr）を用いて認識することができる。分割が許容されない場合の符号化単位（CU）は、予測単位（Prediction unit：PU）としてみなされ、復号器は、PUの位置をPUインデックスを用いて認識することができる。

10

#### 【0022】

予測単位（PU）は、複数個のパーティションに分けられることができる。また、予測単位（PU）は、複数個の変換単位（Transform unit：TU）で構成され得る。

#### 【0023】

符号化モード決定部110は、決定された符号化モードによる所定サイズのブロック単位（例えば、PU単位またはTU単位）で映像データを減算器180に送る。

#### 【0024】

変換符号化・量子化部140は、減算器180により算出された残差ブロックを空間領域から周波数領域に変換する。例えば、残差ブロックに対して2次元の離散コサイン変換（DCT）または離散サイン変換（DST）基盤の変換を実行する。また、変換符号化・量子化部140は、変換係数を量子化するための量子化ステップサイズを決定し、決定された量子化ステップサイズを用いて変換係数を量子化する。決定された量子化ステップサイズ及び符号化モードによって量子化マトリックスが決定され得る。

20

#### 【0025】

量子化された2次元の変換係数は、予め決められたスキャニング方法のうち、1つにより1次元の量子化変換係数に変換される。前記変換された1次元の量子化変換係数のシーケンスは、エントロピ符号化部150に供給される。

#### 【0026】

逆量子化・変換復号化部141は、変換符号化・量子化部140により量子化された量子化係数を逆量子化する。また、逆量子化により得られる逆量子化係数を逆変換する。これにより、周波数領域に変換された残差ブロックを空間領域の残差ブロックに復元することができる。

30

#### 【0027】

デブロッキングフィルタリング部160は、逆量子化・変換復号化部141から逆量子化及び逆変換された映像データを受信してブロッキング（blocking）効果を除去するためのフィルタリングを行う。

#### 【0028】

ピクチャー保存部170は、フィルタリングされた映像データをデブロッキングフィルタリング部160から受信してピクチャー（picture）単位に映像を復元して保存する。ピクチャーは、フレーム単位の映像であるか、フィールド単位の映像でありうる。ピクチャー保存部170は、複数のピクチャーを保存できるバッファ（図示せず）を備える。バッファに保存された複数のピクチャーは、イントラ予測及び動き推定のために提供される。イントラ予測または動き推定のために提供される前記ピクチャーは参照ピクチャーと呼ばれる。

40

#### 【0029】

動き推定部131は、前記ピクチャー保存部170に保存された少なくとも1つの参照ピクチャーが提供されて、動き推定を行って動きベクトル、参照ピクチャーを表すインデックス、及びブロックモードを含むモーションデータ（Motion Data）を出力

50

する。

#### 【0030】

予測精度を最適化するために、少数画素精度、例えば、 $1/2$ または $1/4$ 画素精度で動きベクトルを決定する。動きベクトルが少数画素精度を有し得るので、動き補償部130は、少数画素位置の画素値を算出するための補間フィルタを参照ピクチャーに適用することにより、整数画素位置の画素値から少数画素位置の画素値を算出する。

#### 【0031】

動き補償部130は、動き推定部131から入力されたモーションデータによって、ピクチャー復元部135に保存された複数の参照ピクチャーのうち、動き推定に用いられた参照ピクチャーから、符号化しようとするブロックに対応する予測ブロックを抽出して出力する。

10

#### 【0032】

動き補償部130は、少数精度の動き補償に必要な適応的補間フィルタのフィルタ特性を決定する。フィルタ特性は、例えば、適応的補間フィルタのフィルタタイプを表す情報及び適応的補間フィルタのサイズを表す情報などである。フィルタのサイズは、例えば、適応的補間フィルタのフィルタ係数の数であるタブ数などである。

#### 【0033】

具体的に、動き補償部130は、適応的補間フィルタとして、分離型及び非分離型適応的フィルタのうち、いずれか1つを決定することができる。次いで、決定された適応的補間フィルタのタブ数及び各フィルタ係数の値を決定する。フィルタ係数の値は、整数画素との相対的な少数画素の位置ごとに異なるように決定され得る。また、動き補償部130は、フィルタ係数が固定である複数個の非適応的補間フィルタを用いることもできる。

20

#### 【0034】

動き補償部130は、補間フィルタの特性を所定の処理単位に設定することができる。例えば、少数画素単位、符号化基本単位（符号化ユニット）、スライス単位、ピクチャー単位、またはシーケンス単位に設定することができる。また、1個の映像データに対して、1個の特性を設定してもよい。したがって、所定の処理単位内では、同じフィルタ特性を利用するので、動き補償部130は、フィルタ特性を一時的に維持するメモリを備える。このメモリは必要に応じて、フィルタ特性及びフィルタ係数などを維持する。例えば、動き補償部130は、1ピクチャーごとにフィルタ特性を決定し、スライス単位にフィルタ係数を決定することができる。

30

#### 【0035】

動き補償部130は、ピクチャー保存部170から参照ピクチャーを受信し、決定された適応的補間フィルタを用いてフィルタ処理を適用することにより、少数精度の予測参照画像を生成する。

#### 【0036】

そして、生成された参照画像と、動き推定部131により決定された動きベクトルとに基づいて少数画素精度の動き補償を行うことにより、予測ブロックを生成する。

#### 【0037】

減算部180は、符号化しようとする入力ブロックをピクチャー間予測符号化する場合、動き補償予測部137から入力ブロックに対応する参照ピクチャー内のブロックを受信して入力マクロブロックとの差分演算を行って残差信号（residue signal）を出力する。

40

#### 【0038】

イントラ予測部120は、予測が行われるピクチャー内部の再構成された画素値を用いてイントラ予測符号化を行う。イントラ予測部は、予測符号化する現在ブロックを受信して現在ブロックのサイズによって予め設定された複数個のイントラ予測モードのうち、1つを選択してイントラ予測を行う。イントラ予測部120は、現在ブロックに隣接した以前に符号化された画素を用いて現在ブロックのイントラ予測モードを決定し、前記決定されたモードに対応する予測ブロックを生成する。

50

## 【0039】

現在ピクチャーに含まれた領域のうち、以前に符号化された領域は、イントラ予測部120が利用できるように再度復号化されてピクチャー保存部170に保存されている。イントラ予測部120は、ピクチャー保存部170に保存されている現在ピクチャーの以前に符号化された領域で現在ブロックに隣接した画素または隣接しないが、適用可能な画素を用いて現在ブロックの予測ブロックを生成する。

## 【0040】

イントラ予測部120は、イントラブロックを予測するために隣接画素を適応的にフィルタリングすることができる。復号器における同じ動作のために、符号器でフィルタリング可否を報知する情報を伝送することができる。または、現在ブロックのイントラ予測モード及び現在ブロックのサイズ情報に基づいてフィルタリング可否を決定することができる。

10

## 【0041】

映像符号化装置により使用される予測タイプは、前記符号化モード決定部により入力ブロックがイントラモードまたはインターモードに符号化されるか否かに依存する。

## 【0042】

イントラモードとインターモードとの切換は、イントラ・インター切換スイッチにより制御される。

## 【0043】

エントロピ符号化部150は、変換符号化・量子化部140により量子化された量子化係数と動き推定部131により生成された動き情報とをエントロピ符号化する。また、イントラ予測モード、制御データ（例えば、量子化ステップサイズ等）等も符号化され得る。さらに、動き補償部130により決定されたフィルタ係数も符号化されてビットストリームとして出力する。

20

## 【0044】

図2は、本発明に係るイントラ予測部120の動作を示したブロック図である。

## 【0045】

まず、符号化モード決定部110により予測モード情報及び予測ブロックのサイズを受信する(S110)。予測モード情報は、イントラモードを表す。予測ブロックのサイズは、 $64 \times 64$ 、 $32 \times 32$ 、 $16 \times 16$ 、 $8 \times 8$ 、 $4 \times 4$ 等の正方形でありうるが、これに限定しない。すなわち、前記予測ブロックのサイズが正方形でない非正方形でありうる。

30

## 【0046】

次に、予測ブロックのイントラ予測モードを決定するために、参照画素をピクチャー保存部170から読み込む。前記利用可能でない参照画素が存在するか否かを検討して参照画素生成可否を判断する(S120)。前記参照画素は、現在ブロックのイントラ予測モードを決定するのに使用される。

## 【0047】

現在ブロックが現在ピクチャーの上側境界に位置する場合には、現在ブロックの上側に隣接した画素が定義されない。また、現在ブロックが現在ピクチャーの左側境界に位置する場合には、現在ブロックの左側に隣接した画素が定義されない。このような画素は、利用可能な画素でないものと判断する。さらに、現在ブロックがスライス境界に位置して、スライスの上側または左側に隣接する画素が先に符号化されて復元される画素でない場合にも、利用可能な画素でないものと判断する。

40

## 【0048】

上記のように、現在ブロックの左側または上側に隣接した画素が存在しないか、予め符号化されて復元された画素が存在しない場合には、利用可能な画素のみを用いて現在ブロックのイントラ予測モードを決定することもできる。

## 【0049】

しかし、現在ブロックの利用可能な参照画素を用いて利用可能でない位置の参照画素を

50

生成することもできる（S 1 3 0）。例えば、上側ブロックの画素が利用可能でない場合には、左側画素の一部または全部を用いて上側画素を生成することができ、その逆にも可能である。すなわち、利用可能でない位置の参照画素から予め決められた方向に最も近い位置の利用可能な参照画素を複製して参照画素として生成することができる。予め決められた方向に利用可能な参照画素が存在しない場合には、反対方向の最も近い位置の利用可能な参照画素を複製して参照画素として生成することができる。

#### 【0050】

一方、現在ブロックの上側または左側画素が存在する場合にも、前記画素が属するブロックの符号化モードによって利用可能でない参照画素として決定され得る。例えば、現在ブロックの上側に隣接した参照画素が属するブロックがインター符号化されて復元されたブロックである場合には、前記画素を利用可能でない画素として判断することができる。この場合には、現在ブロックに隣接したブロックがイントラ符号化されて復元されたブロックに属する画素を用いて利用可能な参照画素を生成することができる。この場合には、符号器で符号化モードによって利用可能な参照画素を判断するという情報を復号器に伝送しなければならない。

10

#### 【0051】

次に、前記参照画素を用いて現在ブロックのイントラ予測モードを決定する（S 1 4 0）。現在ブロックに許容可能なイントラ予測モードの数は、ブロックのサイズによって変わることができる。例えば、現在ブロックのサイズが $8 \times 8$ 、 $16 \times 16$ 、 $32 \times 32$ である場合には、34個のイントラ予測モードが存在でき、現在ブロックのサイズが $4 \times 4$ である場合には、17個のイントラ予測モードが存在できる。前記34個または17個のイントラ予測モードは、少なくとも1つ以上の非方向性モード（non-directional mode）と複数個の方向性モード（directional modes）とで構成され得る。1つ以上の非方向性モードは、DCモード及び／又はプラナー（planar）モードでありうる。DCモード及びプラナーモードが非方向性モードに含まれる場合には、現在ブロックのサイズに関係なく、35個のイントラ予測モードが存在することもできる。このときには、2個の非方向性モード（DCモード及びプラナーモード）と33個の方向性モードとを含むことができる。

20

#### 【0052】

プラナーモードは、現在ブロックの右下側（bottom-right）に位置する少なくとも1つの画素値（または前記画素値の予測値、以下、第1の参照値とする）と参照画素とを用いて現在ブロックの予測ブロックを生成する。

30

#### 【0053】

図3を参照してプラナーモードを説明する。図3は、現在ブロックが $8 \times 8$ ブロックである場合のプラナーモード予測を説明するための図である。

#### 【0054】

現在ブロックの右下側（bottom-right）に位置する第1の参照値Dと現在ブロックの左側に隣接する現在ブロックの最も下方の画素に隣接する画素値Cとを用いて、その間に位置する画素に対応する予測画素を生成する。同様に、前記第1の参照値Dと現在ブロックの上側に隣接する画素とのうち、現在ブロックの最も右側の画素と隣接する画素値Bを用いて、その間に位置する画素に対応する予測画素を生成する。前記予測画素を生成するために、線形結合を使用することができる。しかし、画素の配置が線形でない場合には、予め決められた非線形結合で前記予測画素を生成することができる。

40

#### 【0055】

次に、生成された予測画素（すなわち、画素CとDとの間の画素及び画素BとDとの間の画素）及び現在ブロックに隣接した画素（すなわち、AとBとの間の画素及びAとCとの間の画素）を用いて残りの予測画素を生成する。前記予測画素は、上側及び左側に隣接した2個の画素及び下側及び右側に生成された2個の画素を線形結合して生成することができる。また、前記結合は、必ず線形である必要はなく、画素の分布を考慮した非線形結合でありうる。このように、プラナーモードでは、予測画素を生成するために使用される

50

参照画素の数が予測画素の位置によって変わり得る。

【0056】

一方、現在ブロックの左側参照画素は利用可能であるが、上側参照画素が利用可能でない場合が生じ得る。このときには、前記第1の参照値または前記左側参照画素のうち、1つを用いて前記上側参照画素を生成することができる。すなわち、左側参照画素のみ利用可能な場合には、左側参照画素のうち、最上側に位置した参照画素を複製して上側参照画素を生成することができ、前記第1の参照値と前記上側画素とに最も近接した位置にある参照画素を用いてBとDとの間の予測画素を生成することができる。

【0057】

同様に、現在ブロックの上側参照画素は利用可能であるが、左側参照画素が利用可能でない場合には、前記上側参照画素のうち、最左側に位置した参照画素を複製して左側参照画素を生成することができ、前記左側参照画素と第1の参照値とを用いてCとDとの間の予測画素を生成することができる。

10

【0058】

一方、前記第1の参照値またはこれを表す情報は、ビットストリームに追加されて復号器に伝送されるか、復号器が前記第1の参照値を導くこともできる。

【0059】

前記第1の参照値またはこれを表す情報を復号器に伝送する方法を利用する場合には、現在ブロックに隣接した、符号化されて復元された画素のうち、少なくとも1つ以上を用いた第1の参照値の予測値と前記第1の参照値との差分値を伝送することがビット数を減らし得る。このために、前記第1の参照値の予測値は、(1)現在ブロックに隣接した参照画素の平均値、(2)A、B、Cの平均値、(3)BとCの平均値のうち、いずれか1つでありうる。もう1つの方法では、AとCの差分値とAとBの差分値とを比較して、差分値が小さい方向を表すいずれか1つ(BまたはC)に決定することもできる。

20

【0060】

前記第1の参照値を符号器と復号器が導く場合には、符号器と復号器が同じ参照値を導くことができなければならない。このために、符号器では、第1の参照値を生成するために参照画素A、B、Cを用いることができる。画面が平坦に変わるという仮定下では、(1)BとAとの差分値をCに足した値またはCとAとの差分値をBに足した値、すなわち(B+C-A)、(2)BとCとの平均値のうち、いずれか1つを第1の参照値として設定することができる。この場合、B、Cの代わりに、Bの隣接参照画素及びCの隣接参照画素を用いることもできる。このように、符号器と復号器とが同様に第1の参照値を復元できるので、第1の参照値またはこれを表す情報を復号器に伝送する必要がなく、伝送ビット数を減らすことができる。

30

【0061】

次に、現在ブロックのイントラ予測モードが決定されれば、予測ブロックを生成する(S150)。前記予測ブロックは、現在ブロックのイントラ予測モードに基づいて参照画素(生成された画素を含む)またはこれらの線形結合を用いて生成する。DCモードは、現在ブロックに隣接した参照画素の平均値を用いて現在ブロックの予測ブロックを生成する。前記参照画素は、利用可能な参照画素及び生成された参照画素を全て含むことができる。

40

【0062】

次に、現在ブロックのイントラ予測モードが決定されれば、前記イントラ予測モードを符号化する(S160)。前記イントラ予測モードの符号化は、イントラ予測部120で行われることができ、別のイントラ予測モード符号化装置(図示せず)またはエントロピ符号化部150で行われることもできる。

【0063】

一方、現在ブロックに隣接した参照ブロックの数が様々な場合には、前記参照ブロックの境界に位置する参照画素間に段差が生じ得る。この場合、予測ブロック生成後の残差ブロックは、高周波成分を多く含有する可能性が高くなる。したがって、参照ブロック間の

50

ブロッキングアーティファクト ( b l o c k i n g a r t i f a c t ) が現在のブロックにも影響を及ぼすという問題が生じる。このような問題は、現在ブロックのサイズが大きいほど頻度数が高まるようになる。逆に、参照ブロックのサイズが現在ブロックのサイズより大きい場合には、このような問題が生じない可能性もある。

#### 【0064】

したがって、上記の問題点を克服するための1つの方法は、前記参照画素を適応的にフィルタリングして新しい参照画素を生成することである。これは、イントラ予測モードを決定する前に行うこともできる。イントラ予測モード及び予測ブロックのサイズによって予め前記参照画素を適応的にフィルタリングして新しい参照画素を生成し、元の参照画素及び前記生成された新しい参照画素を用いて現在ブロックのイントラ予測モードを決定することもできる。しかし、現在ブロックのイントラ予測モードを決定した後に上記の方法を行うこともできる。ブロッキングアーティファクトの問題は、ブロックのサイズが大きくなるほど大きくなるので、特定サイズのブロックの範囲では、ブロックのサイズが大きくなるほど参照画素をフィルタリングする予測モードの数を同じあるか、大きくすることができる。

10

#### 【0065】

前記利用可能な参照画素のフィルタリングが必要な場合には、前記した参照画素間の段差の程度によって2個以上のフィルタを適応的に適用することもできる。前記フィルタは、低域通過フィルタであることが好ましい。例えば、2個のフィルタを用いる場合、第1のフィルタは3-tapフィルタ、第2のフィルタは5-tapフィルタでありうる。第2のフィルタは、第1のフィルタを2回適用するフィルタでありうる。前記フィルタのフィルタ係数は、対称的なことが好ましい。または、複雑度の減少のために、1個のフィルタのみを使用することもできる。

20

#### 【0066】

また、前記したフィルタが、現在ブロック (イントラ予測が行われるブロック) のサイズによって適応的に適用されることが好ましい。すなわち、フィルタを適用する場合、現在ブロックのサイズが第1のサイズより小さい場合には、帯域幅が狭いフィルタを適用するか、フィルタを適用しないこともありうるし、第1のサイズ~第2のサイズの現在ブロックに対しては、フィルタを適用するイントラ予測モードの数を増加させることが好ましい。前記イントラ予測が行われる現在ブロックは、変換ブロックのサイズでありうる。

30

#### 【0067】

DCモードの場合には、参照画素の平均値で予測ブロックが生成されるので、フィルタを適用する必要がない。すなわち、フィルタを適用する場合、不要な演算量のみが多くなる。また、映像が垂直方向に連関性 ( c o r r e l a t i o n ) のある垂直モードでは、参照画素にフィルタを適用する必要がない。映像が水平方向に連関性のある水平モードでも、参照画素にフィルタを適用する必要がない。このように、フィルタリングの適用可否は、現在ブロックのイントラ予測モードとも連関性があるので、現在ブロックのイントラ予測モード及びイントラ予測が行われるブロックのサイズに基づいて参照画素を適応的にフィルタリングすることができる。イントラ予測が行われるブロックのサイズが予め決められたサイズ (例えば、4×4) より小さい場合には、参照画素をフィルタリングしない。または、複雑度の減少のために、予め決められたサイズより大きい場合にも、参照画素をフィルタリングしないこともありうる。前記ブロックのサイズが予め決められたサイズ範囲内に属する場合には、対角線方向のイントラ予測モード (水平または垂直モードと45度角度の方向性を有するモード) と水平方向のイントラ予測モードとの間のイントラ予測モードのうち、いずれか1つのモードで参照画素がフィルタリングされれば、前記モードと対角線方向のイントラ予測モード間の方向性モードでは、参照画素をフィルタリングする。

40

#### 【0068】

上記の問題点を克服するためのさらに他の方法は、前記参照画素を用いて生成された予測ブロックの一部画素を適応的にフィルタリングして新しい予測ブロックを生成すること

50

である。現在ブロックのイントラ予測モードによって予測ブロックの予測画素のうち、参照画素と接する予測画素を少なくとも1つ以上の参照画素を用いて補正することができる。これは、予測ブロック生成時に共に適用されることもできる。

#### 【0069】

例えば、DCモードでは、予測画素のうち、参照画素と接する予測画素は、前記予測画素と接する参照画素を用いてフィルタリングする。したがって、予測画素の位置によって1個または2個の参照画素を用いて予測画素をフィルタリングする。DCモードにおける予測画素のフィルタリングは、全てのサイズの予測ブロックに適用することができる。

#### 【0070】

垂直モードでは、予測ブロックの予測画素のうち、左側参照画素と接する予測画素は、前記予測ブロックを生成するのに用いられる上側画素以外の参照画素を用いて変更され得る。同様に、水平モードでは、生成された予測画素のうち、上側参照画素と接する予測画素は、前記予測ブロックを生成するのに用いられる左側画素以外の参照画素を用いて変更され得る。

10

#### 【0071】

一方、現在ブロックと前記イントラ予測部120により生成された予測ブロックとの残差ブロックは、変換符号化・量子化部140及びエントロピ符号化部150を介して符号化される。

#### 【0072】

前記残差ブロックは、先に変換符号化される。効果的なエネルギー圧縮のために、前記残差ブロックに適用する変換符号化のための変換ブロックのサイズを先に決定し、決定されたサイズのブロック単位で変換符号化する。または、変換のサイズは予め決定されていることもありうる。この場合、イントラ予測を行う現在ブロックのサイズが変換ブロックのサイズでありうる。イントラ予測モード値によって互いに異なる変換符号化方式が適用され得る。例えば、DC modeにイントラ予測された残差ブロックに対しては、水平及び垂直方向に整数基盤DCT (Discrete cosine transform) を、プラナーモード (planar mode) に対しては水平及び垂直方向に整数基盤DST (Discrete sine transform) を適用することもできる。これは、所定サイズより小さいか、同じブロックに対して適用することができる。しかし、所定サイズより大きい変換ブロックに対しては、イントラ予測モードに関係なく、整数基盤DCTのみを適用することもできる。水平及び垂直方向DCT方式とDST方式が予測モードによって適応的に適用されることもできる。

20

30

#### 【0073】

次に、変換符号化された残差ブロックが量子化する。残差ブロックのサイズによって互いに異なる量子化マトリックスが適用される。また、同じサイズの残差ブロックの場合にも、互いに異なる量子化マトリックスが適用され得る。すなわち、変換符号化された残差ブロックの係数の分布に基づいて、少なくとも2個以上の量子化マトリックスのうち、最も効果的な量子化マトリックスを適用することができる。この場合には、前記量子化マトリックスを表す情報を復号器に伝送する。また、イントラ予測モードによって互いに異なる量子化マトリックスを変換符号化された残差ブロックに適用することもできる。

40

#### 【0074】

次に、前記2次元の量子化された係数を予め決められた複数個のスキャンパターンのうち、1つを選択して1次元の量子化係数シーケンスに変更した後、エントロピ符号化する。前記スキャンパターンは、イントラ予測モードによって決定されることができ、イントラ予測モードと変換ブロックとのサイズによって決定されることもできる。

#### 【0075】

図4は、本発明の実施形態に係る動画像復号化装置を示したブロック図である。

#### 【0076】

図4に示すように、本発明に係る動画像復号化装置は、エントロピ復号化部210、逆量子化・逆変換部220、加算器270、デブロッキングフィルタリング部250、ピク

50



チャー保存部 260、イントラ予測部 230、動き補償予測部 240、及びイントラ・インター切替スイッチ 280を備える。

【0077】

エントロピ復号化部 210は、動画像符号化装置から伝送される符号化ビットストリームを復号して、イントラ予測モードインデックス、動き情報、量子化係数シーケンスなどに分離する。エントロピ復号化部 210は、復号された動き情報を動き補償予測部 240に供給する。エントロピ復号化部 210は、前記イントラ予測モードインデックスを前記イントラ予測部 230、逆量子化・逆変換部 220に供給する。また、前記エントロピ復号部 210は、前記逆量子化係数シーケンスを逆量子化・逆変換部 220に供給する。

【0078】

逆量子化・逆変換部 220は、前記量子化係数シーケンスを2次元配列の逆量子化係数に変換する。前記変換のために、複数個のスキヤニングパターンのうち、1つを選択する。現在ブロックの予測モード（すなわち、イントラ予測及びインター予測のうち、いずれか1つ）とイントラ予測モードと変換ブロックとのサイズに基づいて複数個のスキヤニングパターンのうち、1つを選択する。前記イントラ予測モードは、イントラ予測部またはエントロピ復号化部から受信する。

【0079】

逆量子化・逆変換部 220は、前記2次元配列の逆量子化係数に複数個の量子化マトリックスのうち、選択された量子化マトリックスを用いて量子化係数を復元する。前記量子化マトリックスは、符号器から受信された情報を利用して決定されることもできる。復元しようとする現在ブロック（変換ブロック）のサイズによって互いに異なる量子化マトリックスが適用され、同一サイズのブロックに対しても、前記現在ブロックの予測モード及びイントラ予測モードのうち、少なくとも1つに基づいて量子化マトリックスを選択することができる。そして、前記復元された量子化係数を逆変換して残差ブロックを復元する。

【0080】

加算器 270は、逆量子化・逆変換部 220により復元された残差ブロックとイントラ予測部 230または動き補償予測部 240により生成される予測ブロックとを加算することにより、映像ブロックを復元する。

【0081】

デブロッキングフィルタリング部 250は、加算器 270により生成された復元映像にデブロッキングフィルタ処理を実行する。これにより、量子化過程による映像損失に基づくデブロッキングアーティファクトを減らすことができる。

【0082】

ピクチャー保存部 260は、デブロッキングフィルタリング部 250によりデブロッキングフィルタ処理が実行されたローカル復号映像を維持するフレームメモリである。

【0083】

イントラ予測部 230は、エントロピ復号化部 210から受信されたイントラ予測モードインデックスに基づいて現在ブロックのイントラ予測モードを復元する。そして、復元されたイントラ予測モードによって予測ブロックを生成する。

【0084】

動き補償予測部 240は、動きベクトル情報に基づいてピクチャー保存部 240に保存されたピクチャーから現在ブロックに対する予測ブロックを生成する。少数精度の動き補償が適用される場合には、選択された補間フィルタを適用して予測ブロックを生成する。

【0085】

イントラ・インター切替スイッチ 280は、符号化モードに基づいてイントラ予測部 250と動き補償予測部 260とのうち、いずれか1つで生成された予測ブロックを加算器 270に提供する。

【0086】

以下、前記図4を参照して、現在ブロックをイントラ予測を介して復元する過程を説明

IPR2021-00827

10

20

30

40

50

する。図5は、本発明の実施形態に係るイントラブロックを復元するための順序図である。

【0087】

まず、受信されたビットストリームから現在ブロックのイントラ予測モードを復号する(S310)。

【0088】

このために、エントロピ復号化部210は、複数個のイントラ予測モードテーブルのうち1つを参照して現在ブロックの第1のイントラ予測モードインデックスを復元する。

【0089】

前記複数個のイントラ予測モードテーブルは、符号器と復号器が共有するテーブルであって、現在ブロックに隣接した複数個のブロックのイントラ予測モードの分布によって選択されたいずれか1つのテーブルが適用され得る。一例として、現在ブロックの左側ブロックのイントラ予測モードと現在ブロックの上側ブロックのイントラ予測モードとが同じであれば、第1のイントラ予測モードテーブルを適用して現在ブロックの第1のイントラ予測モードインデックスを復元し、同じでなければ、第2のイントラ予測モードテーブルを適用して現在ブロックの第1のイントラ予測モードインデックスを復元することができる。さらに他の例として、現在ブロックの上側ブロックと左側ブロックのイントラ予測モードが共に方向性予測モード(*directional intra prediction mode*)である場合には、前記上側ブロックのイントラ予測モードの方向と前記左側ブロックのイントラ予測モードの方向とが所定角度以内であれば、第1のイントラ予測モードテーブルを適用して現在ブロックの第1のイントラ予測モードインデックスを復元し、所定角度を外れれば、第2のイントラ予測モードテーブルを適用して現在ブロックの第1のイントラ予測モードインデックスを復元することもできる。

【0090】

エントロピ復号化部210は、復元された現在ブロックの第1のイントラ予測モードインデックスをイントラ予測部230に伝送する。前記第1のイントラ予測モードインデックスを受信したイントラ予測部230は、前記インデックスが最小値を有する場合(すなわち、0)には、現在ブロックの最大可能モードを現在ブロックのイントラ予測モードとして決定する。しかし、前記インデックスが0以外の値を有する場合には、現在ブロックの最大可能モードが表すインデックスと前記第1のイントラ予測モードインデックスとを比較する。比較の結果、前記第1のイントラ予測モードインデックスが前記現在ブロックの最大可能モードが表すインデックスより小さくなければ、前記第1のイントラ予測モードインデックスに1を足した第2のイントラ予測モードインデックスに対応するイントラ予測モードを現在ブロックのイントラ予測モードとして決定し、それとも、前記第1のイントラ予測モードインデックスに対応するイントラ予測モードを現在ブロックのイントラ予測モードとして決定する。

【0091】

現在ブロックに許容可能なイントラ予測モードは、少なくとも1つ以上の非方向性モード(*non-directional mode*)と複数個の方向性モード(*directional modes*)とで構成され得る。1つ以上の非方向性モードは、DCモード及び/又はプラナー(*planar*)モードでありうる。また、DCモードとプラナーモードのうち、いずれか1つが適応的に前記許容可能なイントラ予測モードセットに含まれ得る。このために、ピクチャーヘッダまたはスライスヘッダに前記許容可能なイントラ予測モードセットに含まれる非方向性モードを特定する情報が含まれ得る。

【0092】

次に、イントラ予測部230は、イントラ予測ブロックを生成するために、参照画素をピクチャー保存部260から読み込み、利用可能でない参照画素が存在するか否かを判断する(S320)。前記判断は、現在ブロックの復号されたイントラ予測モードを適用してイントラ予測ブロックを生成するのに用いられる参照画素の存在可否によって行なわれることもできる。

## 【0093】

次に、イントラ予測部230は、参照画素を生成する必要がある場合には、予め復元された利用可能な参照画素を用いて利用可能でない位置の参照画素を生成する（S325）。利用可能でない参照画素に対する定義及び参照画素の生成方法は、図2によるイントラ予測部120における動作と同様である。ただし、現在ブロックの復号されたイントラ予測モードによってイントラ予測ブロックを生成するのに用いられる参照画素のみを選択的に復元することもできる。

## 【0094】

次に、イントラ予測部230は、予測ブロックを生成するために、参照画素にフィルタを適用するか否かを判断する（S330）。すなわち、イントラ予測部230は、現在ブロックのイントラ予測ブロックを生成するために、参照画素に対してフィルタリングを適用するか否かを前記復号されたイントラ予測モード及び現在予測ブロックのサイズに基づいて決定する。ブロックングアーティファクトの問題は、ブロックのサイズが大きくなるほど大きくなるので、ブロックのサイズが大きくなるほど参照画素をフィルタリングする予測モードの数を増加させることができる。しかし、ブロックが所定サイズより大きくなる場合には、平坦な領域とみなすことができるので、複雑度の減少のために参照画素をフィルタリングしないこともありうる。

## 【0095】

前記参照画素にフィルタ適用が必要であると判断された場合には、フィルタを用いて前記参照画素をフィルタリングする（S335）。

## 【0096】

前記した参照画素間の段差の程度によって少なくとも2個以上のフィルタを適応的に適用することもできる。前記フィルタのフィルタ係数は対称的であることが好ましい。

## 【0097】

また、前記した2個以上のフィルタが現在ブロックのサイズによって適応的に適用されることもできる。すなわち、フィルタを適用する場合、サイズが小さいブロックに対しては帯域幅が狭いフィルタを、サイズが大きいブロックに対しては帯域幅が広いフィルタを適用することもできる。

## 【0098】

DCモードの場合には、参照画素の平均値で予測ブロックが生成されるので、フィルタを適用する必要がない。すなわち、フィルタを適用する場合、不要な演算量のみが多くなる。また、映像が垂直方向に連関性（*correlation*）のある垂直モードでは、参照画素にフィルタを適用する必要がない。映像が水平方向に連関性のある水平モードでも、参照画素にフィルタを適用する必要がない。このように、フィルタリングの適用可否は、現在ブロックのイントラ予測モードとも連関性があるので、現在ブロックのイントラ予測モード及び予測ブロックのサイズに基づいて参照画素を適応的にフィルタリングすることができる。

## 【0099】

次に、前記復元されたイントラ予測モードによって、前記参照画素または前記フィルタリングされた参照画素を用いて予測ブロックを生成する（S340）。前記予測ブロックの生成は、図2の符号器における動作と同じであるため、省略する。プラナーモードの場合にも、図2の符号器における動作と同じであるため、省略する。

## 【0100】

次に、前記生成された予測ブロックをフィルタリングするか否かを判断する（S350）。前記フィルタリング可否の判断は、スライスヘッダまたは符号化ユニットヘッダに含まれた情報を利用することができる。また、現在ブロックのイントラ予測モードによって決定されることもできる。

## 【0101】

前記生成された予測ブロックをフィルタリングするものと判断する場合、生成された予測ブロックをフィルタリングする（S335）。具体的に、現在ブロックに隣接した利用

可能な参照画素を用いて生成された予測ブロックの特定位置の画素をフィルタリングして新しい画素を生成する。これは、予測ブロック生成時に共に適用されることもできる。例えば、DCモードでは、予測画素のうち、参照画素と接する予測画素は、前記予測画素と接する参照画素を用いてフィルタリングする。したがって、予測画素の位置によって1個または2個の参照画素を用いて予測画素をフィルタリングする。DCモードにおける予測画素のフィルタリングは、全てのサイズの予測ブロックに適用することができる。垂直モードでは、予測ブロックの予測画素のうち、左側参照画素と接する予測画素は、前記予測ブロックを生成するのに用いられる上側画素以外の参照画素を用いて変更され得る。同様に、水平モードでは、生成された予測画素のうち、上側参照画素と接する予測画素は、前記予測ブロックを生成するのに用いられる左側画素以外の参照画素を用いて変更され得る。

10

【0102】

このような方式で復元された現在ブロックの予測ブロックと復号化した現在ブロックの残差ブロックとを用いて現在ブロックが復元される。

【0103】

上記では、本発明の好ましい実施形態を参照して説明したが、当該技術分野の熟練された当業者は、下記の特許請求の範囲に記載された本発明の思想及び領域から逸脱しない範囲内で本発明を様々に修正及び変更させることができるということが理解できるであろう。

【図1】

FIG. 1

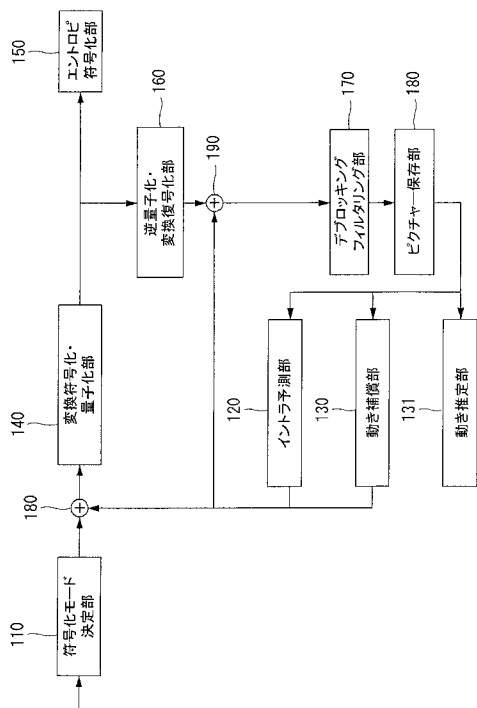

【図2】

FIG. 2

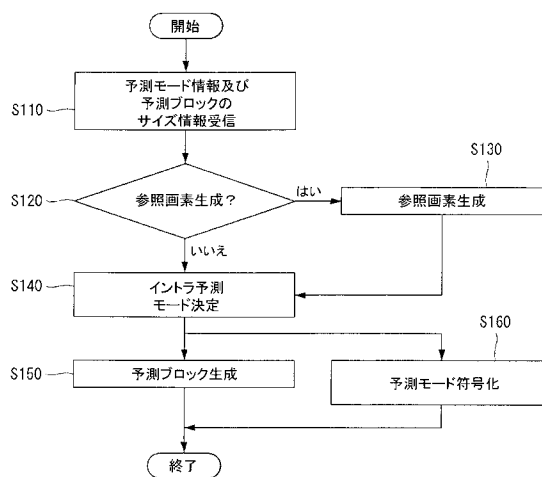

【図3】

[Fig. 3]

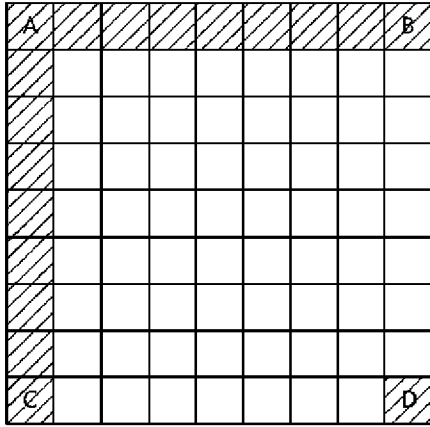

【図4】

FIG. 4

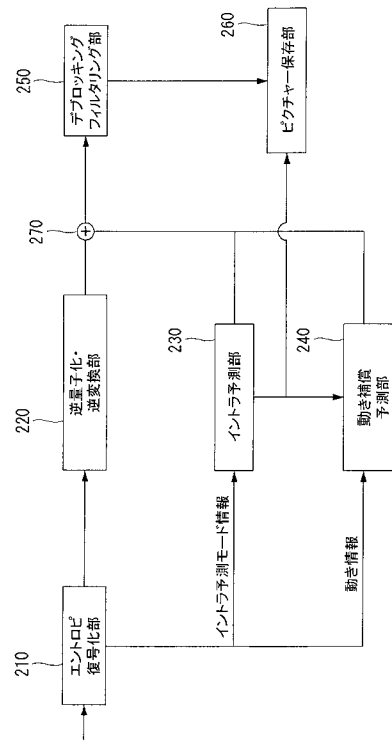

【図5】

FIG. 5

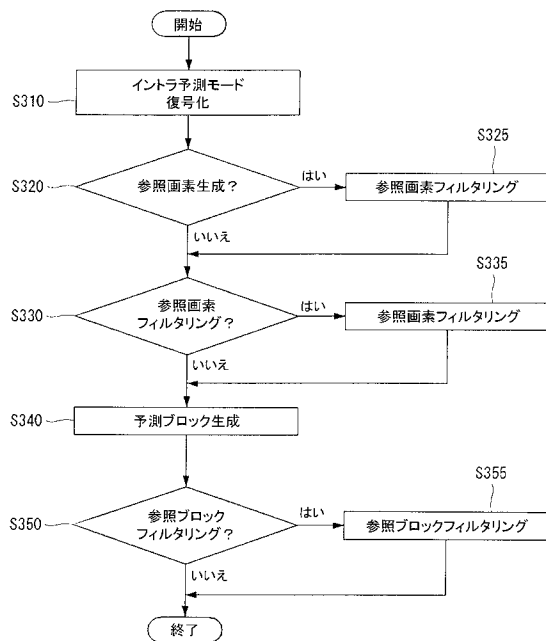

## 【国際調査報告】

## INTERNATIONAL SEARCH REPORT

International application No.

PCT/KR2012/001923

A. CLASSIFICATION OF SUBJECT MATTER <b>H04N 7/34(2006.01)i</b> According to International Patent Classification (IPC) or to both national classification and IPC		
B. FIELDS SEARCHED Minimum documentation searched (classification system followed by classification symbols) H04N 7/34; H04N 7/24; H04N 7/32; H04N 7/26  Documentation searched other than minimum documentation to the extent that such documents are included in the fields searched Korean Utility models and applications for Utility models: IPC as above Japanese Utility models and applications for Utility models: IPC as above  Electronic data base consulted during the international search (name of data base and, where practicable, search terms used) eKOMPASS (KIPO internal) & Keywords: "intra prediction, filtering"		
C. DOCUMENTS CONSIDERED TO BE RELEVANT		
Category*	Citation of document, with indication, where appropriate, of the relevant passages	Relevant to claim No.
A	KR 10-2011-0018189 A (SAMSUNG ELECTRONICS CO., LTD.) 23 February 2011 See abstract, figure 2, page 5, [0034]-[0042] and claim 1.	1-9
A	KR 10-2010-0132973 A (THOMSON LICENSING) 20 December 2010 See abstract, page 14, [0121]-[0131] and claim 1.	1-9
A	EP 2293567 A2 (SAMSUNG ELECTRONICS CO., LTD.) 09 March 2011 See abstract and figure 1.	1-9
<input type="checkbox"/> Further documents are listed in the continuation of Box C. <input checked="" type="checkbox"/> See patent family annex.		
<p>* Special categories of cited documents:</p> <p>"A" document defining the general state of the art which is not considered to be of particular relevance</p> <p>"E" earlier application or patent but published on or after the international filing date</p> <p>"C" document which may throw doubts on priority claim(s) or which is cited to establish the publication date of another citation or other special reason (as specified)</p> <p>"O" document referring to an oral disclosure, use, exhibition or other means</p> <p>"P" document published prior to the international filing date but later than the priority date claimed</p> <p>"T" later document published after the international filing date or priority date and not in conflict with the application but cited to understand the principle or theory underlying the invention</p> <p>"X" document of particular relevance; the claimed invention cannot be considered novel or cannot be considered to involve an inventive step when the document is taken alone</p> <p>"Y" document of particular relevance; the claimed invention cannot be considered to involve an inventive step when the document is combined with one or more other such documents, such combination being obvious to a person skilled in the art</p> <p>"&amp;" document member of the same patent family</p>		
Date of the actual completion of the international search <b>08 OCTOBER 2012 (08.10.2012)</b>		Date of mailing of the international search report <b>08 OCTOBER 2012 (08.10.2012)</b>
Name and mailing address of the ISA/KR Korean Intellectual Property Office Government Complex-Daejeon, 139 Seonsa-ro, Daejeon 302-701, Republic of Korea Facsimile No. 82-42-472-7140		Authorized officer  Telephone No.

Form PCT/ISA/210 (second sheet) (July 2009)

**INTERNATIONAL SEARCH REPORT**  
Information on patent family members

International application No.

**PCT/KR2012/001923**

Patent document cited in search report	Publication date	Patent family member	Publication date
KR 10-2011-0018189 A	23.02.2011	CA 2768694 A1	24.02.2011
		CN 102464719 A	30.05.2012
		EP 2454683 A2	23.05.2012
		US 2011-0038415 A1	17.02.2011
		US 2012-0140824 A1	07.06.2012
		WO 2011-021839 A2	24.02.2011
KR 10-2010-0132973 A	20.12.2010	CN 102090062 A	08.06.2011
		EP 2263381 A1	22.12.2010
		JP 2011-517230 A	26.05.2011
		WO 2009-126299 A1	15.10.2009
EP 2293567 A2	09.03.2011	AU 2009-258401 A1	17.12.2009
		CN 102124739 A	13.07.2011
		JP 2011-523321 A	04.08.2011
		KR 10-2009-0129926 A	17.12.2009
		US 2011-0090967 A1	21.04.2011
		WO 2009-151232 A2	17.12.2009

Form PCT/ISA/210 (patent family annex) (July 2009)

국제조사보고서

국제출원번호  
PCT/KR2012/001923

A. 발명이 속하는 기술분류(국제특허분류(IPC))	
H04N 7/34(2006.01)i	
B. 조사된 분야	
조사된 최소문헌(국제특허분류를 기재) H04N 7/34; H04N 7/24; H04N 7/32; H04N 7/26	
조사된 기술분야에 속하는 최소문헌 이외의 문헌 한국등록실용신안공보 및 한국공개실용신안공보: 조사된 최소문헌란에 기재된 IPC 일본등록실용신안공보 및 일본공개실용신안공보: 조사된 최소문헌란에 기재된 IPC	
국제조사에 이용된 전산 데이터베이스(데이터베이스의 명칭 및 검색어(해당하는 경우)) KOMPASS(특허청 내부 검색시스템) & 키워드: "인트라 예측, 필터링"	
C. 관련 문헌	
카테고리*	인용문헌명 및 관련 구절(해당하는 경우)의 기재
A	KR 10-2011-0018189 A (삼성전자주식회사) 2011.02.23 요약, 도면2, 페이지5, [0034]-[0042] 및 청구항1.
A	KR 10-2010-0132973 A (롬슨 라이선싱) 2010.12.20 요약, 페이지14, [0121]-[0131] 및 청구항1.
A	EP 2293567 A2 (SAMSUNG ELECTRONICS CO., LTD.) 2011.03.09 요약 및 도면1.
	관련 청구항
	1-9
	1-9
	1-9
<input type="checkbox"/> 추가 문헌이 C(계속)에 기재되어 있습니다. <input checked="" type="checkbox"/> 대응특허에 관한 별지를 참조하십시오.	
* 인용된 문헌의 특별 카테고리: "A" 특별히 관련이 없는 것으로 보이는 일반적인 기술수준을 정의한 문헌 "T" 국제출원일 또는 우선일 후에 공개된 문헌으로, 출원과 상충하지 않으며 발명의 기초가 되는 원리나 이론을 이해하기 위해 인용된 문헌 "E" 국제출원일보다 빠른 출원일 또는 우선일을 가지나 국제출원일 이후에 공개된 선출원 또는 특허 문헌 "X" 특별한 관련이 있는 문헌. 해당 문헌 하나만으로 청구된 발명의 신규성 또는 진보성이 없는 것으로 본다. "I" 우선권 주장에 의문을 제기하는 문헌 또는 다른 인용문헌의 공개일 또는 다른 특별한 이유(이유를 명시)를 밝히기 위하여 인용된 문헌 "Y" 특별한 관련이 있는 문헌. 해당 문헌이 하나 이상의 다른 문헌과 조합하는 경우로 그 조합이 당업자에게 자명한 경우 청구된 발명은 진보성이 없는 것으로 본다. "O" 구두 개시, 사용, 전시 또는 기타 수단을 언급하고 있는 문헌 "P" 우선일 이후에 공개되었으나 국제출원일 이전에 공개된 문헌 "&" 동일한 대응특허문헌에 속하는 문헌	
국제조사의 실제 완료일 2012년 10월 08일 (08.10.2012)	국제조사보고서 발송일 2012년 10월 08일 (08.10.2012)
ISA/KR의 명칭 및 우편주소 대한민국 특허청 (302-701) 대전광역시 서구 청사로 189, 4동 (문산동, 정부대전청사) 팩스 번호 82-42-472-7140	심사관 김영태 전화번호 82-42-481-8367

서식 PCT/ISA/210 (두 번째 용지) (2009년 7월)





국제조사보고서  
대응특허에 관한 정보

국제출원번호  
**PCT/KR2012/001923**

국제조사보고서에서 인용된 특허문헌	공개일	대응특허문헌	공개일
KR 10-2011-0018189 A	2011.02.23	CA 2768694 A1	2011.02.24
		CN 102484719 A	2012.05.30
		EP 2454883 A2	2012.05.23
		US 2011-0038415 A1	2011.02.17
		US 2012-0140824 A1	2012.06.07
		WO 2011-021839 A2	2011.02.24
KR 10-2010-0132973 A	2010.12.20	CN 102090062 A	2011.06.08
		EP 2263381 A1	2010.12.22
		JP 2011-517230 A	2011.05.26
		WO 2009-126299 A1	2009.10.15
EP 2293567 A2	2011.03.09	AU 2009-258401 A1	2009.12.17
		CN 102124739 A	2011.07.13
		JP 2011-523321 A	2011.08.04
		KR 10-2009-0129926 A	2009.12.17
		US 2011-0090967 A1	2011.04.21
		WO 2009-151232 A2	2009.12.17

서식 PCT/ISA/210 (대응특허 추가용지) (2009년 7월)

## フロントページの続き

(81)指定国 AP(BW, GH, GM, KE, LR, LS, MW, MZ, NA, RW, SD, SL, SZ, TZ, UG, ZM, ZW), EA(AM, AZ, BY, KG, KZ, MD, RU, TJ, TM), EP(AL, AT, BE, BG, CH, CY, CZ, DE, DK, EE, ES, FI, FR, GB, GR, HR, HU, IE, IS, IT, LT, LU, LV, MC, MK, MT, NL, NO, PL, PT, RO, RS, SE, SI, SK, SM, TR), OA(BF, BJ, CF, CG, CI, CM, GA, GN, GQ, GW, ML, MR, NE, SN, TD, TG), AE, AG, AL, AM, AO, AT, AU, AZ, BA, BB, BG, BH, BR, BW, BY, BZ, CA, CH, CL, CN, CO, CR, CU, CZ, DE, DK, DM, DO, DZ, EC, EE, EG, ES, FI, GB, GD, GE, GH, GM, GT, HN, HR, HU, ID, IL, IN, IS, JP, KE, KG, KM, KN, KP, KR, KZ, LA, LC, LK, LR, LS, LT, LU, LY, MA, MD, ME, MG, MK, MN, MW, MX, MY, MZ, NA, NG, NI, NO, NZ, OM, PE, PG, PH, PL, PT, QA, RO, RS, RU, RW, SC, SD, SE, SG, SK, SL, SM, ST, SV, SY, TH, TJ, TM, TN, TR, TT, TZ, UA, UG, US, UZ, VC, VN

(72)発明者 キム, クワンジェ

大韓民国・136-130・ソウル・ソンプクーグ・ハウオルコグードン・222・ドゥーサン  
 アパートメント・108-501

(72)発明者 オウ, ヒュノウ

大韓民国・427-739・ギョンギード・グワチヨンシ・ウォンムンードン・レミアン シュ  
 ル・322-1102

Fターム(参考) 5C159 KK03 MA04 MA05 MA21 MC14 MC38 ME01 NNO1 NN28 PPO4

PP25 TA69 TB08 TC24 TC26 UA02 UA05 UA12 UA16 UA18

UA33

【公報種別】特許法第17条の2の規定による補正の掲載

【部門区分】第7部門第3区分

【発行日】平成27年5月7日(2015.5.7)

【公表番号】特表2014-512129(P2014-512129A)

【公表日】平成26年5月19日(2014.5.19)

【年通号数】公開・登録公報2014-026

【出願番号】特願2014-502448(P2014-502448)

【国際特許分類】

**H 0 4 N 19/50 (2014.01)**

【F I】

H 0 4 N 7/137 Z

【手続補正書】

【提出日】平成27年3月16日(2015.3.16)

【手続補正1】

【補正対象書類名】特許請求の範囲

【補正対象項目名】全文

【補正方法】変更

【補正の内容】

【特許請求の範囲】

【請求項1】

イントラ予測モードにおける映像復号化方法であって、  
現在ブロックのイントラ予測モードを復元するステップと、  
現在ブロックの利用可能でない参照画素が存在すれば、利用可能な参照画素を用いて参照画素を生成するステップと、

現在ブロックの前記復元されたイントラ予測モード及び現在ブロックのサイズに基づいて、前記参照画素を適応的にフィルタリングするステップと、

現在ブロックのイントラ予測モード及び前記参照画素を用いて現在ブロックの予測ブロックを生成するステップと、

を含み、

前記参照画素を生成するステップは、前記利用可能でない参照画素の位置から予め決められた方向に最も近い位置の利用可能な参照画素の画素値を利用可能でない参照画素の画素値として設定し、

前記参照画素をフィルタリングするためのフィルタは、前記現在ブロックおよび参照画素間の段差を用いて選択されることを特徴とする映像復号化方法。

【請求項2】

前記利用可能でない参照画素の位置から予め決められた方向に利用可能な参照画素が存在しなければ、反対方向の最も近い位置の利用可能な参照画素の画素値を利用可能でない参照画素の画素値として設定することを特徴とする請求項1に記載の映像復号化方法。

【請求項3】

現在ブロックの残差ブロックを逆量子化し、逆変換する過程をさらに含み、前記逆量子化のために、符号器から受信された情報により決定される量子化マトリックスを用いて前記残差ブロックを逆量子化することを特徴とする請求項1に記載の映像復号化方法。

【請求項4】

前記参照画素を適応的にフィルタリングするステップは、現在ブロックのイントラ予測モードが水平または垂直モードであれば、参照画素をフィルタリングしないことを特徴とする請求項1に記載の映像復号化方法。

【請求項5】

水平モードと対角線方向のイントラ予測モード間の特定方向を有するイントラ予測モー

IPR2021-00827

ドで参照画素がフィルタリングされれば、前記特定方向のイントラ予測モードと前記対角線方向のイントラ予測モードとの間の方向性モードでは、参照画素をフィルタリングすることを特徴とする請求項1に記載の映像復号化方法。

【請求項6】

現在ブロックのイントラ予測モードが垂直モードであれば、予測ブロックの左側境界予測画素は、予測ブロック生成に用いられる上側画素以外の参照画素を用いて変更されることを特徴とする請求項1に記載の映像復号化方法。

【請求項7】

現在ブロックのイントラ予測モードがプラナーモードであれば、現在ブロックの第1の参照値、現在ブロックの右上側コーナ参照画素と接する参照画素、及び現在ブロックの左下側コーナ画素と接する参照画素を用いて予測ブロックの右側境界及び下側境界に位置する予測画素を生成することを特徴とする請求項1に記載の映像復号化方法。

【請求項8】

前記第1の参照値は、現在ブロックの2個の予め決められた位置の画素の画素値の平均値を用いて生成することを特徴とする請求項7に記載の映像復号化方法。

【請求項9】

現在ブロックの予測モードがDCモードであれば、現在ブロックのサイズに関係なく、予測ブロックの予測画素のうち、参照画素と接する予測画素を前記少なくとも1つ以上の参照画素を用いてフィルタリングすることを特徴とする請求項1に記載の映像復号化方法。

。

## Electronic Acknowledgement Receipt

<b>EFS ID:</b>	23328771
<b>Application Number:</b>	14825825
<b>International Application Number:</b>	
<b>Confirmation Number:</b>	1431
<b>Title of Invention:</b>	METHOD AND APPARATUS FOR PERFORMING INTRA-PREDICTION USING ADAPTIVE FILTER
<b>First Named Inventor/Applicant Name:</b>	Jin Ho LEE
<b>Customer Number:</b>	96767
<b>Filer:</b>	Woochoon William Park/Lena Maxey
<b>Filer Authorized By:</b>	Woochoon William Park
<b>Attorney Docket Number:</b>	PA0929-2C
<b>Receipt Date:</b>	27-AUG-2015
<b>Filing Date:</b>	13-AUG-2015
<b>Time Stamp:</b>	13:35:42
<b>Application Type:</b>	Utility under 35 USC 111(a)

### Payment information:

Submitted with Payment	no
------------------------	----

### File Listing:

Document Number	Document Description	File Name	File Size(Bytes)/ Message Digest	Multi Part /.zip	Pages (if appl.)
1	Information Disclosure Statement (IDS) Form (SB08)	PA0929-2C_IDS_sb08a_.pdf	612242 <small>f68470c5797442bae025cee636131a69595e4dc6</small>	no	4

### Warnings:

### Information:

IPR2021-00827

A U.S. Patent Number Citation or a U.S. Publication Number Citation is required in the Information Disclosure Statement (IDS) form for autoloading of data into USPTO systems. You may remove the form to add the required data in order to correct the Informational Message if you are citing U.S. References. If you chose not to include U.S. References, the image of the form will be processed and be made available within the Image File Wrapper (IFW) system. However, no data will be extracted from this form. Any additional data such as Foreign Patent Documents or Non Patent Literature will be manually reviewed and keyed into USPTO systems.

2	Foreign Reference	WO2012134085.pdf	4033914 677e84512ab06d7c09dfd11be5631faf9cbe83716	no	50
---	-------------------	------------------	--	----	----

**Warnings:**

**Information:**

3	Non Patent Literature	Description_of_video_coding_technology_proposal_by_ETRI.pdf	556943 34cf0fb0d73ede806aa6a5e633efea285f38f1a	no	9
---	-----------------------	---	---	----	---

**Warnings:**

**Information:**

<b>Total Files Size (in bytes):</b>			5203099		
-------------------------------------	--	--	---------	--	--

**This Acknowledgement Receipt evidences receipt on the noted date by the USPTO of the indicated documents, characterized by the applicant, and including page counts, where applicable. It serves as evidence of receipt similar to a Post Card, as described in MPEP 503.**

**New Applications Under 35 U.S.C. 111**

**If a new application is being filed and the application includes the necessary components for a filing date (see 37 CFR 1.53(b)-(d) and MPEP 506), a Filing Receipt (37 CFR 1.54) will be issued in due course and the date shown on this Acknowledgement Receipt will establish the filing date of the application.**

**National Stage of an International Application under 35 U.S.C. 371**

**If a timely submission to enter the national stage of an international application is compliant with the conditions of 35 U.S.C. 371 and other applicable requirements a Form PCT/DO/EO/903 indicating acceptance of the application as a national stage submission under 35 U.S.C. 371 will be issued in addition to the Filing Receipt, in due course.**

**New International Application Filed with the USPTO as a Receiving Office**

**If a new international application is being filed and the international application includes the necessary components for an international filing date (see PCT Article 11 and MPEP 1810), a Notification of the International Application Number and of the International Filing Date (Form PCT/RO/105) will be issued in due course, subject to prescriptions concerning national security, and the date shown on this Acknowledgement Receipt will establish the international filing date of the application.**

Under the Paperwork Reduction Act of 1995, no persons are required to respond to a collection of information unless it displays a valid OMB control number.

# Request to Retrieve Electronic Priority Application(s)

COMPLETE IF KNOWN

Application Number	
Filing Date	
First Named Inventor	Jin Ho LEE
Art Unit	
Examiner Name	
Attorney Docket Number	PA0929-2C

Send completed form to: Commissioner for Patents  
P.O. Box 1450, Alexandria, VA 22313-1450

The undersigned hereby requests the USPTO retrieve an electronic copy of each of the following foreign applications for which priority has been claimed under 35 U.S.C. 119(a)-(d) from a foreign intellectual property office participating with the USPTO in a bilateral or multilateral priority document exchange agreement:

Please retrieve (check all that apply)

- From EPO, JPO, or KIPO (participating foreign intellectual property office) a priority application
  - Column A.** Participating office where application was originally filed
  - Column B.** Application number and filing date of the application
- From WIPO (participating foreign intellectual property office) a DAS registered priority application
  - Column A.** DAS Depositing Office where application was originally filed
  - Column B.** Application number and filing date of the application
- Copy of certified copy of non-participating office priority document from within a participating foreign intellectual property office application (EPO or JPO)
  - Column A.** Participating office where certified copy of priority document is located
  - Column B.** Application number and filing date of the EPO/JPO application
  - Column C.** Two letter country code and application number of the non-EPO/JPO priority document

	A	B		C	
	Participating Office (e.g., EPO, JPO, KIPO) or DAS Depositing Office (e.g., IB)	Application to be retrieved or application containing the non-participating priority application		Non-participating priority application to be retrieved	
		App. No.	Filing Date	Country Code	App. No.
1	KIPO	10-2010-0032778	2010-04-09		
2	KIPO	10-2011-0026079	2011-03-23		
3	KIPO	10-2011-0032766	2011-04-08		
4					
5					
6					

This Request to Retrieve Electronic Priority Application(s) (Request) should be filed within the later of four months from the date of filing of the above-identified U.S. application claiming foreign priority, or sixteen months from the filing date of the foreign application to which priority is claimed.

This Request should be submitted concurrently with the claim for priority, or thereafter. The USPTO will not attempt to retrieve the identified priority application(s) until applicant indicates the identified priority application(s) on the oath or declaration or an application data sheet in compliance with 37 CFR 1.63(c).

Applicants are advised to consult Private PAIR (accessed through www.uspto.gov) to assure that the retrieval has been successful. The applicant remains ultimately responsible for the submission of the certified copy of the foreign application(s) within the period set forth in 37 CFR 1.55(a) (before the U.S. application issues as a patent) if the USPTO does not timely retrieve the identified priority application(s).

I hereby declare that I have the authority to grant access to the above-identified foreign application(s).

**/WOOCHOON W. PARK/**

Signature

**WOOCHOON W. PARK**

Printed or Typed Name

**Patent Attorney**

Title

**2015-08-13**

Date

**630.908.7652**

Telephone Number

**55523**

Registration Number, if applicable

This collection of information is required by 37 CFR 1.55(d). The information is required to obtain or retain a benefit by the public which is to file (and by the USPTO to process an application). Confidentiality is governed by 35 U.S.C. 122 and 37 CFR 1.11 and 1.14. This collection is estimated to take 8 minutes to complete, including gathering, preparing, and submitting the completed application form to the USPTO. Time will vary depending upon the individual case. Any comments on the amount of time you require to complete this form and/or suggestions for reducing this burden, should be sent to the Chief Information Officer, U.S. Patent and Trademark Office, U.S. Department of Commerce, P.O. Box 1450, Alexandria, VA 22313-1450. DO NOT SEND FEES OR COMPLETED FORMS TO THIS ADDRESS. SEND TO: Commissioner for Patents, P.O. Box 1450, Alexandria, VA 22313-1450.

If you need assistance in completing the form, call 1-800-PTO-9199 and select option 2.

## Privacy Act Statement

The Privacy Act of 1974 (P.L. 93-579) requires that you be given certain information in connection with your submission of the attached form related to a patent application or patent. Accordingly, pursuant to the requirements of the Act, please be advised that: (1) the general authority for the collection of this information is 35 U.S.C. 2(b)(2); (2) furnishing of the information solicited is voluntary; and (3) the principal purpose for which the information is used by the U.S. Patent and Trademark Office is to process and/or examine your submission related to a patent application or patent. If you do not furnish the requested information, the U.S. Patent and Trademark Office may not be able to process and/or examine your submission, which may result in termination of proceedings or abandonment of the application or expiration of the patent.

The information provided by you in this form will be subject to the following routine uses:

1. The information on this form will be treated confidentially to the extent allowed under the Freedom of Information Act (5 U.S.C. 552) and the Privacy Act (5 U.S.C. 552a). Records from this system of records may be disclosed to the Department of Justice to determine whether the Freedom of Information Act requires disclosure of these records.
2. A record from this system of records may be disclosed, as a routine use, in the course of presenting evidence to a court, magistrate, or administrative tribunal, including disclosures to opposing counsel in the course of settlement negotiations.
3. A record in this system of records may be disclosed, as a routine use, to a Member of Congress submitting a request involving an individual, to whom the record pertains, when the individual has requested assistance from the Member with respect to the subject matter of the record.
4. A record in this system of records may be disclosed, as a routine use, to a contractor of the Agency having need for the information in order to perform a contract. Recipients of information shall be required to comply with the requirements of the Privacy Act of 1974, as amended, pursuant to 5 U.S.C. 552a(m).
5. A record related to an International Application filed under the Patent Cooperation Treaty in this system of records may be disclosed, as a routine use, to the International Bureau of the World Intellectual Property Organization, pursuant to the Patent Cooperation Treaty.
6. A record in this system of records may be disclosed, as a routine use, to another federal agency for purposes of National Security review (35 U.S.C. 181) and for review pursuant to the Atomic Energy Act (42 U.S.C. 218(c)).
7. A record from this system of records may be disclosed, as a routine use, to the Administrator, General Services, or his/her designee, during an inspection of records conducted by GSA as part of that agency's responsibility to recommend improvements in records management practices and programs, under authority of 44 U.S.C. 2904 and 2906. Such disclosure shall be made in accordance with the GSA regulations governing inspection of records for this purpose, and any other relevant (i.e., GSA or Commerce) directive. Such disclosure shall not be used to make determinations about individuals.
8. A record from this system of records may be disclosed, as a routine use, to the public after either publication of the application pursuant to 35 U.S.C. 122(b) or issuance of a patent pursuant to 35 U.S.C. 151. Further, a record may be disclosed, subject to the limitations of 37 CFR 1.14, as a routine use, to the public if the record was filed in an application which became abandoned or in which the proceedings were terminated and which application is referenced by either a published application, an application open to public inspections or an issued patent.
9. A record from this system of records may be disclosed, as a routine use, to a Federal, State, or local law enforcement agency, if the USPTO becomes aware of a violation or potential violation of law or regulation.



Under the Paperwork Reduction Act of 1995, no persons are required to respond to a collection of information unless it displays a valid OMB control number.

**TRANSMITTAL FOR POWER OF ATTORNEY TO ONE OR MORE REGISTERED PRACTITIONERS**

**NOTE:** This form is to be submitted with the Power of Attorney by Applicant form (PTO/AIA/82B or equivalent) to identify the application to which the Power of Attorney is directed, in accordance with 37 CFR 1.5. If the Power of Attorney by Applicant form is not accompanied by this transmittal form or an equivalent, the Power of Attorney will not be recognized in the application.

Application Number	
Filing Date	
First Named Inventor	Jin Ho LEE
Title	METHOD AND APPARATUS FOR PERFORMING INTRA-PREDICTION USING ADAPTIVE FILTER
Art Unit	
Examiner Name	
Attorney Docket Number	PA0929-2C

**SIGNATURE of Applicant or Patent Practitioner**

Signature	/Woochoon W. Park/	Date	2015-08-13
Name	Woochoon W. Park	Telephone	630-908-7652
Registration Number	55523		

**NOTE:** This form must be signed in accordance with 37 CFR 1.33. See 37 CFR 1.4(d) for signature requirements and certifications.

\*Total of \_\_\_\_\_ forms are submitted.

This collection of information is required by 37 CFR 1.31, 1.32 and 1.33. The information is required to obtain or retain a benefit by the public which is to file (and by the USPTO to process) an application. Confidentiality is governed by 35 U.S.C. 122 and 37 CFR 1.11 and 1.14. This collection is estimated to take 3 minutes to complete, including gathering, preparing, and submitting the completed application form to the USPTO. Time will vary depending upon the individual case. Any comments on the amount of time you require to complete this form and/or suggestions for reducing this burden, should be sent to the Chief Information Officer, U.S. Patent and Trademark Office, U.S. Department of Commerce, P.O. Box 1450, Alexandria, VA 22313-1450. DO NOT SEND FEES OR COMPLETED FORMS TO THIS ADDRESS. **SEND TO: Commissioner for Patents, P.O. Box 1450, Alexandria, VA 22313-1450.**

*If you need assistance in completing the form, call 1-800-PTO-9199 and select option 2.*

# POWER OF ATTORNEY BY APPLICANT

I hereby revoke all previous powers of attorney given in the application identified in the attached transmittal letter.

I hereby appoint Practitioner(s) associated with the following Customer Number as my/our attorney(s) or agent(s), and to transact all business in the United States Patent and Trademark Office connected therewith for the application referenced in the attached transmittal letter (form PTO/AIA/82A or equivalent):

96767

OR

I hereby appoint Practitioner(s) named below as my/our attorney(s) or agent(s), and to transact all business in the United States Patent and Trademark Office connected therewith for the application referenced in the attached transmittal letter (form PTO/AIA/82A or equivalent):

Name	Registration Number	Name	Registration Number

Please recognize or change the correspondence address for the application identified in the attached transmittal letter to:

The address associated with the above-mentioned Customer Number.

OR

The address associated with Customer Number:

OR

[Empty address box]

Firm or Individual Name

Address

City

State

Zip

Country

Telephone

Email

I am the Applicant:

Inventor or Joint Inventor

Legal Representative of a Deceased or Legally Incapacitated Inventor

Assignee or Person to Whom the Inventor is Under an Obligation to Assign

Person Who Otherwise Shows Sufficient Proprietary Interest (e.g., a petition under 37 CFR 1.46(b)(2) was granted in the application or is concurrently being filed with this document)

### SIGNATURE of Applicant for Patent

Signature

/Gilwon KIM/

Date

2013-02-05

Name

KIM, Gilwon

Telephone

042-860-4908

Title and Company

Director and Electronics & Telecommunications Research Institute

**NOTE:** Signature - This form must be signed by the applicant in accordance with 37 CFR 1.33. See 37 CFR 1.4 for signature requirements and certifications. Submit multiple forms for more than one signature, see below \*.

\*Total of \_\_\_\_\_ forms are submitted.

This collection of information is required by 37 CFR 1.31, 1.32 and 1.33. The information is required to obtain or retain a benefit by the public which is to file (and by the USPTO to process) an application. Confidentiality is governed by 35 U.S.C. 122 and 37 CFR 1.11 and 1.14. This collection is estimated to take 3 minutes to complete, including gathering, preparing, and submitting the completed application form to the USPTO. Time will vary depending upon the individual case. Any comments on the amount of time you require to complete this form and/or suggestions for reducing this burden, should be sent to the Chief Information Officer, U.S. Patent and Trademark Office, U.S. Department of Commerce, P.O. Box 1450, Alexandria, VA 22313-1450. DO NOT SEND FEES OR COMPLETED FORMS TO THIS ADDRESS. SEND TO: **Commissioner for Patents, P.O. Box 1450, Alexandria, VA 22313-1450.**

If you need assistance in completing the form, call 1-800-PTO-9199 and select option 2.

## Privacy Act Statement

The **Privacy Act of 1974 (P.L. 93-579)** requires that you be given certain information in connection with your submission of the attached form related to a patent application or patent. Accordingly, pursuant to the requirements of the Act, please be advised that: (1) the general authority for the collection of this information is 35 U.S.C. 2(b)(2); (2) furnishing of the information solicited is voluntary; and (3) the principal purpose for which the information is used by the U.S. Patent and Trademark Office is to process and/or examine your submission related to a patent application or patent. If you do not furnish the requested information, the U.S. Patent and Trademark Office may not be able to process and/or examine your submission, which may result in termination of proceedings or abandonment of the application or expiration of the patent.

The information provided by you in this form will be subject to the following routine uses:

1. The information on this form will be treated confidentially to the extent allowed under the Freedom of Information Act (5 U.S.C. 552) and the Privacy Act (5 U.S.C. 552a). Records from this system of records may be disclosed to the Department of Justice to determine whether disclosure of these records is required by the Freedom of Information Act.
2. A record from this system of records may be disclosed, as a routine use, in the course of presenting evidence to a court, magistrate, or administrative tribunal, including disclosures to opposing counsel in the course of settlement negotiations.
3. A record in this system of records may be disclosed, as a routine use, to a Member of Congress submitting a request involving an individual, to whom the record pertains, when the individual has requested assistance from the Member with respect to the subject matter of the record.
4. A record in this system of records may be disclosed, as a routine use, to a contractor of the Agency having need for the information in order to perform a contract. Recipients of information shall be required to comply with the requirements of the Privacy Act of 1974, as amended, pursuant to 5 U.S.C. 552a(m).
5. A record related to an International Application filed under the Patent Cooperation Treaty in this system of records may be disclosed, as a routine use, to the International Bureau of the World Intellectual Property Organization, pursuant to the Patent Cooperation Treaty.
6. A record in this system of records may be disclosed, as a routine use, to another federal agency for purposes of National Security review (35 U.S.C. 181) and for review pursuant to the Atomic Energy Act (42 U.S.C. 218(c)).
7. A record from this system of records may be disclosed, as a routine use, to the Administrator, General Services, or his/her designee, during an inspection of records conducted by GSA as part of that agency's responsibility to recommend improvements in records management practices and programs, under authority of 44 U.S.C. 2904 and 2906. Such disclosure shall be made in accordance with the GSA regulations governing inspection of records for this purpose, and any other relevant (*i.e.*, GSA or Commerce) directive. Such disclosure shall not be used to make determinations about individuals.
8. A record from this system of records may be disclosed, as a routine use, to the public after either publication of the application pursuant to 35 U.S.C. 122(b) or issuance of a patent pursuant to 35 U.S.C. 151. Further, a record may be disclosed, subject to the limitations of 37 CFR 1.14, as a routine use, to the public if the record was filed in an application which became abandoned or in which the proceedings were terminated and which application is referenced by either a published application, an application open to public inspection or an issued patent.
9. A record from this system of records may be disclosed, as a routine use, to a Federal, State, or local law enforcement agency, if the USPTO becomes aware of a violation or potential violation of law or regulation.

Under the Paperwork Reduction Act of 1995, no persons are required to respond to a collection of information unless it displays a valid OMB control number.

# POWER OF ATTORNEY BY APPLICANT

I hereby revoke all previous powers of attorney given in the application identified in the attached transmittal letter.

I hereby appoint Practitioner(s) associated with the following Customer Number as my/our attorney(s) or agent(s), and to transact all business in the United States Patent and Trademark Office connected therewith for the application referenced in the attached transmittal letter (form PTO/AIA/82A or equivalent):

96767

OR

I hereby appoint Practitioner(s) named below as my/our attorney(s) or agent(s), and to transact all business in the United States Patent and Trademark Office connected therewith for the application referenced in the attached transmittal letter (form PTO/AIA/82A or equivalent):

Name	Registration Number	Name	Registration Number

Please recognize or change the correspondence address for the application identified in the attached transmittal letter to:

The address associated with the above-mentioned Customer Number.

OR

The address associated with Customer Number:

OR

Firm or Individual Name:

Address

City

State

Zip

Country

Telephone

Email

I am the Applicant:

Inventor or Joint Inventor

Legal Representative of a Deceased or Legally Incapacitated Inventor

Assignee or Person to Whom the Inventor is Under an Obligation to Assign

Person Who Otherwise Shows Sufficient Proprietary Interest (e.g., a petition under 37 CFR 1.46(b)(2) was granted in the application or is concurrently being filed with this document)

### SIGNATURE of Applicant for Patent

Signature

Date

Feb 5 2013

Name

KIM, Gilwen

Telephone

042-860-4508

Title and Company

Director and Electronics & Telecommunications Research Institute

NOTE: Signature - This form must be signed by the applicant in accordance with 37 CFR 1.33. See 37 CFR 1.4 for signature requirements and certifications. Submit multiple forms for more than one signature, see below \*.

\*Total of \_\_\_\_\_ forms are submitted.

This collection of information is required by 37 CFR 1.31, 1.32 and 1.33. The information is required to obtain or retain a benefit by the public which is to file (and by the USPTO to process) an application. Confidentiality is governed by 35 U.S.C. 122 and 37 CFR 1.11 and 1.14. This collection is estimated to take 3 minutes to complete, including gathering, preparing, and submitting the completed application form to the USPTO. Time will vary depending upon the individual case. Any comments on the amount of time you require to complete this form and/or suggestions for reducing this burden, should be sent to the Chief Information Officer, U.S. Patent and Trademark Office, U.S. Department of Commerce, P.O. Box 1450, Alexandria, VA 22313-1450. DO NOT SEND FEES OR COMPLETED FORMS TO THIS ADDRESS. SEND TO: Commissioner for Patents, P.O. Box 1450, Alexandria, VA 22313-1450.

If you need assistance in completing the form, call 1-800-PTO-9199 and select option 2

## Privacy Act Statement

The **Privacy Act of 1974 (P.L. 93-579)** requires that you be given certain information in connection with your submission of the attached form related to a patent application or patent. Accordingly, pursuant to the requirements of the Act, please be advised that: (1) the general authority for the collection of this information is 35 U.S.C. 2(b)(2); (2) furnishing of the information solicited is voluntary; and (3) the principal purpose for which the information is used by the U.S. Patent and Trademark Office is to process and/or examine your submission related to a patent application or patent. If you do not furnish the requested information, the U.S. Patent and Trademark Office may not be able to process and/or examine your submission, which may result in termination of proceedings or abandonment of the application or expiration of the patent.

The information provided by you in this form will be subject to the following routine uses:

1. The information on this form will be treated confidentially to the extent allowed under the Freedom of Information Act (5 U.S.C. 552) and the Privacy Act (5 U.S.C. 552a). Records from this system of records may be disclosed to the Department of Justice to determine whether disclosure of these records is required by the Freedom of Information Act.
2. A record from this system of records may be disclosed, as a routine use, in the course of presenting evidence to a court, magistrate, or administrative tribunal, including disclosures to opposing counsel in the course of settlement negotiations.
3. A record in this system of records may be disclosed, as a routine use, to a Member of Congress submitting a request involving an individual, to whom the record pertains, when the individual has requested assistance from the Member with respect to the subject matter of the record.
4. A record in this system of records may be disclosed, as a routine use, to a contractor of the Agency having need for the information in order to perform a contract. Recipients of information shall be required to comply with the requirements of the Privacy Act of 1974, as amended, pursuant to 5 U.S.C. 552a(m).
5. A record related to an International Application filed under the Patent Cooperation Treaty in this system of records may be disclosed, as a routine use, to the International Bureau of the World Intellectual Property Organization, pursuant to the Patent Cooperation Treaty.
6. A record in this system of records may be disclosed, as a routine use, to another federal agency for purposes of National Security review (35 U.S.C. 181) and for review pursuant to the Atomic Energy Act (42 U.S.C. 218(c)).
7. A record from this system of records may be disclosed, as a routine use, to the Administrator, General Services, or his/her designee, during an inspection of records conducted by GSA as part of that agency's responsibility to recommend improvements in records management practices and programs, under authority of 44 U.S.C. 2904 and 2906. Such disclosure shall be made in accordance with the GSA regulations governing inspection of records for this purpose, and any other relevant (*i.e.*, GSA or Commerce) directive. Such disclosure shall not be used to make determinations about individuals.
8. A record from this system of records may be disclosed, as a routine use, to the public after either publication of the application pursuant to 35 U.S.C. 122(b) or issuance of a patent pursuant to 35 U.S.C. 151. Further, a record may be disclosed, subject to the limitations of 37 CFR 1.14, as a routine use, to the public if the record was filed in an application which became abandoned or in which the proceedings were terminated and which application is referenced by either a published application, an application open to public inspection or an issued patent.
9. A record from this system of records may be disclosed, as a routine use, to a Federal, State, or local law enforcement agency, if the USPTO becomes aware of a violation or potential violation of law or regulation.

## Electronic Patent Application Fee Transmittal

<b>Application Number:</b>	
<b>Filing Date:</b>	
<b>Title of Invention:</b>	METHOD AND APPARATUS FOR PERFORMING INTRA-PREDICTION USING ADAPTIVE FILTER
<b>First Named Inventor/Applicant Name:</b>	Jin Ho LEE
<b>Filer:</b>	Woochoon William Park/Peter Yu
<b>Attorney Docket Number:</b>	PA0929-2C

Filed as Small Entity

### Filing Fees for Utility under 35 USC 111(a)

Description	Fee Code	Quantity	Amount	Sub-Total in USD(\$)
<b>Basic Filing:</b>				
Utility filing Fee (Electronic filing)	4011	1	70	70
Utility Search Fee	2111	1	300	300
Utility Examination Fee	2311	1	360	360

**Pages:**

**Claims:**

**Miscellaneous-Filing:**

**Petition:**

**Patent-Appeals-and-Interference:**

IPR2021-00827

Description	Fee Code	Quantity	Amount	Sub-Total in USD(\$)
<b>Post-Allowance-and-Post-Issuance:</b>				
<b>Extension-of-Time:</b>				
<b>Miscellaneous:</b>				
<b>Total in USD (\$)</b>				<b>730</b>

## Electronic Acknowledgement Receipt

<b>EFS ID:</b>	23204918
<b>Application Number:</b>	14825825
<b>International Application Number:</b>	
<b>Confirmation Number:</b>	1431
<b>Title of Invention:</b>	METHOD AND APPARATUS FOR PERFORMING INTRA-PREDICTION USING ADAPTIVE FILTER
<b>First Named Inventor/Applicant Name:</b>	Jin Ho LEE
<b>Customer Number:</b>	96767
<b>Filer:</b>	Woochoon William Park/Peter Yu
<b>Filer Authorized By:</b>	Woochoon William Park
<b>Attorney Docket Number:</b>	PA0929-2C
<b>Receipt Date:</b>	13-AUG-2015
<b>Filing Date:</b>	
<b>Time Stamp:</b>	16:58:11
<b>Application Type:</b>	Utility under 35 USC 111(a)

### Payment information:

Submitted with Payment	yes
Payment Type	Credit Card
Payment was successfully received in RAM	\$730
RAM confirmation Number	3417
Deposit Account	
Authorized User	

The Director of the USPTO is hereby authorized to charge indicated fees and credit any overpayment as follows:

IPR2021-00827



<b>File Listing:</b>					
<b>Document Number</b>	<b>Document Description</b>	<b>File Name</b>	<b>File Size(Bytes)/ Message Digest</b>	<b>Multi Part /.zip</b>	<b>Pages (if appl.)</b>
1	Specification	PA0929-2C_Specification.pdf	118136	no	31
			a5070a3f6f7c85544b9b377fbbab1144e63ea558		
<b>Warnings:</b>					
<b>Information:</b>					
2	Drawings-only black and white line drawings	PA0929-2C_Drawings.pdf	39227	no	9
			d0df73f1657061236c82c28b6157272009ad3d29		
<b>Warnings:</b>					
<b>Information:</b>					
3	Oath or Declaration filed	PA0929-2C_Declaration_Assignment.pdf	2176368	no	6
			a4b43ad76e8c1f063c6e73bcf576438e8db7914a		
<b>Warnings:</b>					
<b>Information:</b>					
4	Application Data Sheet	PA0929-2C_US_ADS_aia14_ETRI.pdf	1396842	no	9
			a3ee68c88270ac1f32d8f0f376b145d70585293e		
<b>Warnings:</b>					
<b>Information:</b>					
5	Request for USPTO to retrieve priority docs	PA0929-2C_RFP_sb38.pdf	110771	no	2
			2c89276b97b60f3df5868530073941a759e987ca		
<b>Warnings:</b>					
<b>Information:</b>					
6	Power of Attorney	PA0929-2C_POA_Form_aia0082_ETRI.pdf	197998	no	3
			294879dc0ebf07017234c6980aea4d58016c6f4d		
<b>Warnings:</b>					
<b>Information:</b>					
7	Power of Attorney	PA0929-2C_WPA-General_POA_ETRI.pdf	248567	no	2
			a61737498e892dd9f2321ee7ccc1b71e21b76ed9		
<b>Warnings:</b>					
<b>Information:</b>					

8	Fee Worksheet (SB06)	fee-info.pdf	35145 0ce5f610dafdd04ff881572a0f537a5332d28ce3	no	2
---	----------------------	--------------	---	----	---

**Warnings:**

**Information:**

<b>Total Files Size (in bytes):</b>	4323054
-------------------------------------	---------

**This Acknowledgement Receipt evidences receipt on the noted date by the USPTO of the indicated documents, characterized by the applicant, and including page counts, where applicable. It serves as evidence of receipt similar to a Post Card, as described in MPEP 503.**

**New Applications Under 35 U.S.C. 111**

**If a new application is being filed and the application includes the necessary components for a filing date (see 37 CFR 1.53(b)-(d) and MPEP 506), a Filing Receipt (37 CFR 1.54) will be issued in due course and the date shown on this Acknowledgement Receipt will establish the filing date of the application.**

**National Stage of an International Application under 35 U.S.C. 371**

**If a timely submission to enter the national stage of an international application is compliant with the conditions of 35 U.S.C. 371 and other applicable requirements a Form PCT/DO/EO/903 indicating acceptance of the application as a national stage submission under 35 U.S.C. 371 will be issued in addition to the Filing Receipt, in due course.**

**New International Application Filed with the USPTO as a Receiving Office**

**If a new international application is being filed and the international application includes the necessary components for an international filing date (see PCT Article 11 and MPEP 1810), a Notification of the International Application Number and of the International Filing Date (Form PCT/RO/105) will be issued in due course, subject to prescriptions concerning national security, and the date shown on this Acknowledgement Receipt will establish the international filing date of the application.**

**【DESCRIPTION】**

**【Invention Title】**

METHOD AND APPARATUS FOR PERFORMING INTRA-PREDICTION USING ADAPTIVE FILTER

**【Technical Field】**

The present invention relates to video coding, and more particularly, to a method and apparatus for performing intra-prediction by applying an adaptive filter to the surrounding pixel values of a block to be predicted or the predicted pixel values of a current block.

**【Background Art】**

With the recent advent of digital TV, etc., technology in the broadcasting TV and home entertainment fields are abruptly being developed. Technology of the fields is being commercialized by the standardization of video compression technology. For video compression, an ITU-T (International Telecommunications Union-Telecommunication) H. 263 standard is being widely used. MPEG-4 which is the next standard of MPEG (Motion Picture Experts Group) is being used for Internet-based video applications.

After the H. 263 standard was completed, ITU-T VCEG (Video Coding Experts Group) has devoted itself to achieve a short-term target for adding additional characteristics to the H. 263 standard and a long-term target for

developing a new standard for visual communication of a low bit rate. In the year of 2001, JVT (Joint Video Team) consisting of the experts of MPEG and VCEG was constructed, and the JVT has performed a standardization task of ITU-T H. 264/MPEG-4 part 10 which is a new standard for the coding of video. The H. 264 standard may also be called AVC (Advanced Video Coding). The technological target of the H. 264/AVC is for the significant improvement of coding efficiency, coding technology robust to loss and error, network-friendly coding technology, low latency capability, accurate match decoding, and so on.

Most of surrounding pixels within video have similar values. The same principle applies to  $4 \times 4$  blocks or  $16 \times 16$  blocks which are a minimum block size of the H. 264/AVC standard. Prediction for the video may be performed using the likeness between inter-block values as described above, and a difference between the video and an original video can be encoded. This is called intra-prediction. The efficiency of video coding can be increased by intra-prediction.

Furthermore, in performs intra-prediction, a filter may be applied before the intra-prediction is performed. In typical cases, when intra-prediction is performed in the H. 264/AVC standard, a filter is applied to reference pixel values, and the values to which the filter has been applied

are used for the intra-prediction. However, the performance of video coding may be increased when the intra-prediction is performed without applying the filter rather than when the intra-prediction is performed after the filter is applied, according to circumstances.

Accordingly, there may be proposed a method of determining whether to apply a filter when performing intra-prediction.

**【Summary of Invention】**

**【Technical Problem】**

An object of the present invention is to provide a method and apparatus for performing intra-prediction by applying an adaptive filter to surrounding pixel values of a block to be predicted or the predicted pixel values of a current block in video encoding. More particularly, after an adaptive filter (i.e., a pre-filter) is applied to reference pixel values of a current block for performing intra-prediction, prediction is performed. Furthermore, a residual signal is calculated after applying an adaptive filter (i.e., a post-filter) to the pixel values of a predicted current block.

**【Technical Solution】**

In an aspect, there is provided a method of performing intra-prediction. The method of performing intra-prediction includes determining whether to apply a first filter to a reference pixel value based on information about

surrounding blocks of a current block, if, as a result of the determination, the first filter is determined to be applied, applying the first filter to the reference pixel values, performing intra-prediction for the current block based on the reference pixel value, determining whether to apply a second filter to a prediction value for each prediction mode of the current block, predicted by performing the intra-prediction based on the information about the surrounding blocks, and if, as a result of the determination, the second filter is determined to be applied, applying the second filter to the prediction values for each prediction mode.

Whether to apply the first filter may be determined based on the prediction mode of the current block determined based on the information about the surrounding blocks.

Whether to apply the first filter may be determined based on the size of the current block.

Whether to apply the first filter may be previously designated based on the prediction mode of the current block and the size of the current block.

Whether to apply the first filter may be determined based on whether the surrounding blocks have been subjected to intra-frame coding or inter-frame coding.

The first filter may be at least any one of a 3-tap filter and a 2-tap

filter.

Whether to apply the second filter may be determined based on the prediction mode of the current block determined based on the information about the surrounding blocks.

Whether to apply the second filter may be determined based on the size of the current block.

Whether to apply the second filter may be determined based on whether the surrounding blocks have been subjected to intra-frame encoding or inter-frame encoding.

The second filter may be applied to prediction values of pixels adjacent to the boundary of the reference pixel value.

The second filter may be at least any one of a 3-tap filter and a 2-tap filter.

In another aspect, there is a provided encoder. The encoder includes a processor and memory connected to the processor and configured to store pieces of information for driving the processor. The processor is configured to determine whether to apply a first filter to a reference pixel value based on information about surrounding blocks of a current block, if, as a result of the determination, the first filter is determined to be applied, apply the first filter to the reference pixel value, perform intra-prediction for the

current block based on the reference pixel value, determine whether to apply a second filter to a prediction value for each prediction mode of the current block, predicted by performing the intra-prediction based on the information about the surrounding blocks, and if, as a result of the determination, the second filter is determined to be applied, apply the second filter to the prediction value for each prediction mode.

In yet another aspect, there is a provided decoder. The decoder includes a processor and memory connected to the processor and configured to store pieces of information for driving the processor. The processor is configured to determine whether to apply a first filter to a reference pixel value based on information about surrounding blocks of a current block, if, as a result of the determination, the first filter is determined to be applied, apply the first filter to the reference pixel value, perform intra-prediction for the current block based on the reference pixel value, determine whether to apply a second filter to a prediction value for each prediction mode of the current block, predicted by performing the intra-prediction based on the information about the surrounding blocks, and if, as a result of the determination, the second filter is determined to be applied, apply the second filter to the prediction value for each prediction mode.

**【Advantageous Effects】**



The performance of coding is improved by effectively predicting a luminance or chrominance signal block to be encoded.

**【Description of Drawings】**

FIG. 1 is a block diagram of an encoder according to the H. 264/AVC (Advanced Video Coding) standard.

FIG. 2 is a block diagram of a decoder according to the H. 264/AVC standard.

FIG. 3 is a diagram showing an example of labeled prediction samples in a  $4 \times 4$  luma prediction mode.

FIG. 4 is a diagram showing 9 kinds of prediction modes within the  $4 \times 4$  luma prediction mode.

FIG. 5 is a diagram showing an example of a method of applying a filter before intra-prediction is performed.

FIG. 6 is a diagram showing an embodiment of a proposed method of performing intra-prediction using an adaptive filter.

FIG. 7 is a diagram showing an example in which a filter is applied to a prediction value according to the proposed method of performing intra-prediction using the adaptive filter.

FIG. 8 is a block diagram of an encoder and a decoder in which the embodiments of the present invention are implemented.

**【Mode for Invention】**

Hereinafter, embodiments of the present invention are described in detail with reference to the accompanying drawings in order for those skilled in the art to be able to readily implement the present invention. However, the present invention may be implemented in various different ways and are not limited to the following embodiments. In order to clarify a description of the present invention, parts not related to the description are omitted, and similar reference numbers are used throughout the drawings to refer to similar parts. Furthermore, a description of parts which can be readily understood by those skilled in the art is omitted.

Furthermore, when it is said that any part "includes (or comprises)" any element, it means that the corresponding part may further include other elements unless otherwise described without excluding the elements.

FIG. 1 is a block diagram of an encoder according to the H. 264/AVC (Advanced Video Coding) standard.

Referring to FIG. 1, the encoder includes two kinds of data flow paths. One of them is a forward path, and the other thereof is a reconstruction path.

First, the forward path is described. Encoding is performed for an input frame  $F_n$  for each macroblock. The macroblock has the size of  $16 \times 16$  pixels in an original video. Intra-prediction or inter-prediction is

performed for each input frame. In the intra-prediction, prediction is performed using a likeness between inter-block values within the frame, and a difference between the original video and a relevant video is encoded. In the inter-prediction, prediction is performed using a likeness between inter-block values between frames, and a difference between the original video and a relevant video is encoded. At the time of the intra-prediction or the inter-prediction, P (i.e., a prediction macroblock) is formed on the basis of the reconstructed frame. At the time of the intra-prediction, the prediction macroblock P may be formed from samples within a previously encoded current frame, a decoded current frame, or a reconstructed current frame  $uF_n'$ . When the prediction macroblock P is formed from the reconstructed current frame, unfiltered samples may be used. At the time of the inter-prediction, the prediction macroblock P may be formed from one or more reference frames through motion compensation or motion prediction. In FIG. 1, it is assumed that the reference frame is a previously encoded frame  $F_{n-1}'$ . However, the present invention is not limited thereto, and each prediction macroblock may be formed from a previous 1 frame or previous 2 frames already encoded or reconstructed, or a subsequent frame or subsequent 2 frames.

P is subtracted from the current macroblock in order to generate a residual or different macroblock  $D_n$ . The macroblock  $D_n$  is transformed (T)

using a block transform and quantized ( $Q$ ), thus generating  $X$ .  $X$  is a set of encoded coefficients. The encoded coefficients are reordered and then subjected to entropy coding. The entropy-coded coefficients form a compressed bit stream, along with information necessary to decode the macroblock. The compressed bit stream is sent to a Network Abstraction Layer (NAL) for transmission or storage.

The reconstruction path is described below. The quantized macroblock coefficients  $X$  are decoded in order to generate a reconstructed frame which is used to encode other macroblocks.  $X$  are inverse quantized ( $Q^{-1}$ ) and then inverse transformed ( $T^{-1}$ ), thus generating a macroblock  $D_n'$ . The difference macroblock  $D_n'$  generated in the reconstruction path is not the same as the difference macroblock  $D_n$  generated in the forward path. Loss is generated because of the quantization, and thus the macroblock  $D_n'$  may have a distorted form of  $D_n$ . The prediction macroblock  $P$  is added to the macroblock  $D_n'$ , and a reconstruction macroblock  $uF_n'$  is generated. The reconstruction macroblock  $uF_n'$  may also have a distorted form of the original macroblock  $F_n$ . In order to reduce blocking distortion for the reconstruction macroblock  $uF_n'$ , a filter may be applied. A reconstructed frame may be formed from a plurality of reconstruction macroblocks to which the filter has been applied.

FIG. 2 is a block diagram of a decoder according to the H. 264/AVC

standard.

Referring to FIG. 2, the decoder receives a compressed bit stream from an NAL. The received data is subjected to entropy decoding in order to generate a set of quantized coefficients  $X$  and then reordered. Inverse quantization and inverse transform are performed for the quantized coefficients  $X$ , thereby generating  $D_n'$ . The decoder generates the same prediction macroblock  $P$  as a prediction macroblock, generated at an encoder, using header information decoded from the bit stream.  $uF_n'$  is generated by adding  $D_n'$  to  $P$ , and  $uF_n'$  may experience a filter, thereby generating a decoded macroblock  $F_n'$ .

Intra-prediction is described below.

When the intra-prediction is performed for a block (or a macroblock), a prediction block (or a macroblock)  $P$  may be formed on the basis of encoded blocks (or macroblocks) or reconstructed blocks (or macroblocks).  $P$  is subtracted from an original video, and a difference from which  $P$  has been subtracted is encoded and then transmitted. The intra-prediction may be performed according to a luma prediction mode or a chroma prediction mode. In the luma prediction mode, the intra-prediction may be performed in the unit of a  $4 \times 4$  sub-block size or a  $16 \times 16$  macroblock size. A total of 9 additional prediction modes exist in the  $4 \times 4$  luma prediction mode, and a

total of 4 additional prediction modes exist in the  $16 \times 16$  luma prediction mode. The unit in which the intra-prediction is performed is not limited to the sub-block or the macroblock, but may be performed using various sizes as the unit. The unit of a pixel in which the intra-prediction is performed may be called a Coding Unit (CU) or a Prediction Unit (PU). The size of the CU or the PU may be the same as the size of a sub-block or a macroblock as described above.

FIG. 3 is a diagram showing an example of labeled prediction samples in the  $4 \times 4$  luma prediction mode. Referring to FIG. 3, a prediction block P is A to H or I to L and is calculated on the basis of labeled samples.

FIG. 4 is a diagram showing 9 kinds of prediction modes within the  $4 \times 4$  luma prediction mode.

An encoder may select any one of the 9 prediction modes for each block in order to minimize a difference between a prediction block P and a block to be encoded. The 9 prediction modes are as follows.

1) mode 0 (vertical): A to D which are upper samples of the prediction block are vertically extrapolated.

2) mode 1 (horizontal): I to L which are left samples of the prediction block are horizontally extrapolated.

3) mode 2 (DC); all the samples A to D and I to L within the prediction

block P are predicted by average.

4) mode 3 (diagonal down-left): samples within the prediction block P are interpolated at an angle of  $45^\circ$  between a left down and a right up.

5) mode 4 (diagonal down-right): samples within the prediction block P are extrapolated right downward at an angle of  $45^\circ$ .

6) mode 5 (vertical-right): samples within the prediction block P are extrapolated or interpolated to the right at an angle of about  $26.6^\circ$  in a vertical axis.

7) mode 6 (horizontal-down): samples within the prediction block P are extrapolated downward at an angle of about  $26.6^\circ$  in a horizontal axis.

8) mode 7 (vertical-left): samples within the prediction block P are extrapolated to the left at an angle of about  $26.6^\circ$  in the vertical axis.

9) mode 8 (horizontal-up): samples within the prediction block P are interpolated upward at an angle of about  $26.6^\circ$  in the horizontal axis.

In FIG. 4, the arrow indicates a direction in which prediction is performed within each mode. Meanwhile, in relation to the mode 3 to the mode 8, the samples within the prediction block P are formed from a weighted average of the prediction samples A to H or I to L. For example, in the mode 4, a sample d placed on the right upper side of the prediction block P may be predicted as  $\text{round}(B/4+C/2+D/4)$ . The encoder calculates the Sum of Absolute

Errors (SAE) for a prediction block generated by each of the prediction modes and performs intra-prediction based on the prediction mode having the smallest SAE.

FIG. 5 is a diagram showing an example of a method of applying a filter before intra-prediction is performed.

In general, a filter is applied to samples used in the H. 264/AVC standard, and intra-prediction is then performed. The samples may also be called reference pixel values. In the example of FIG. 5, it is assumed that a filter is a low-pass filter and is applied to only an  $8 \times 8$  block.

Equation 1 is an example of Equation showing a 3-tap filter applied to a reference pixel value.

<Equation 1>

$$h[Z] = (A + 2 \times Z + Q)/4$$

$$h[A] = (Z + 2 \times A + B)/4$$

...

$$h[P] = (O + 3 \times P)/4$$

$$h[Q] = (Z + 2 \times Q + R)/4$$

...

$$h[X] = (W + 3 \times X)/4$$

$h[Z]$  indicates a value calculated by applying the filter to  $Z$ .



Referring to Equation 1, filtering for the reference pixel value is performed by applying filter coefficients (1,2,1), and intra-prediction according to the 9 prediction modes is performed on the basis of reference pixel values  $h[A] \sim h[Z]$  that has been filtered. Like in the encoding process, the filter may be applied even in a decoding process.

In performing filtering before intra-prediction is performed, the performance of encoding may be improved when the filtering is not performed. Accordingly, a method of performing intra-prediction by adaptively applying the filter may be proposed.

FIG. 6 is a diagram showing an embodiment of the proposed method of performing intra-prediction using an adaptive filter.

Referring to FIG. 6, at step S201, an encoder determines whether to apply the adaptive filter to a reference pixel value. When determining whether to apply the adaptive filter, the encoder may determine whether to apply the adaptive filter on the basis of information about a surrounding block or according to a Rate-Distortion Optimization (RDO) method.

When determining whether to apply the adaptive filter to the reference pixel value based on the information about a surrounding block, a prediction mode of a current block may be determined based on prediction mode information (i.e., a Most Probable Mode (MPM) about the surrounding block,

and whether to apply the adaptive filter to the reference pixel value may be determined according to the determined prediction mode of the current block. For example, assuming that a current block is 'C' , an upper block is 'A' , and a left block is 'B' , when a prediction mode of the current block is the same as a prediction mode of the upper block 'A' , the prediction mode of the upper block 'A' may be determined as the prediction mode of the current block. When the prediction mode of the current block is the same as a prediction mode of the left block 'B' , the prediction mode of the left block 'B' may be determined as the prediction mode of the current block. Alternatively, when the prediction mode of the current block is a prediction mode other than the prediction mode of the upper block 'A' or the prediction mode of the left block 'B' , a relevant prediction mode is encoded and transmitted. Whether to apply the adaptive filter to the reference pixel value may be determined according to the prediction mode of the current block determined as described above. Even when the current block, the upper block, and the left block have different sizes, the prediction mode of a current block may be determined based on the prediction mode of a surrounding block.

Alternatively, in determining whether to apply the adaptive filter to the reference pixel value based on the information about a surrounding block,

whether to apply the adaptive filter may be determined on the basis of a shift in the surrounding reference pixel value. For example, assuming that a reference pixel value to which the filter will be applied is  $p[n]$ , a difference between  $p[n-1]$  and  $p[n+1]$  (i.e., surrounding reference pixel values) may be calculated, and whether to apply the filter may be determined by comparing the difference with a specific threshold.

Alternatively, whether to apply the filter to the reference pixel value may be determined based on the size of a current block other than a prediction mode of the current block. Here, whether to apply the filter is previously designated based on the prediction mode of the current block and the size of the current block, and whether to apply the filter is adaptively determined according to the relevant prediction mode or the relevant size.

Table 1 indicates whether to apply the filter according to the prediction mode of a current block and the size of the current block.

**【Table 1】**

PREDICTION MODE OF CURRENT BLOCK	SIZE OF CURRENT BLOCK			
	4×4	8×8	16×16	32×32
0	0	0	0	0
1	0	0	0	0
2	0	0	0	0
3	1	1	1	1
4	0	1	1	1
...	...	...	...	...

Referring to Table 1, '0' indicates that the filter is not applied, and '1' indicates that the filter is applied. For example, when the size

of the current block is  $4 \times 4$ , if the prediction mode of the current block is 1, the filter may not be applied. If the prediction mode of the current block is 3, the filter may be applied.

Furthermore, whether to apply the filter to the reference pixel value may be determined according to whether surrounding blocks have been subjected to intra-frame encoding or inter-frame encoding. For example, when constrained intra-prediction is performed, a value subjected to the inter-frame encoding is filled with the value of a surrounding block subjected to intra-frame encoding when the surrounding block is subjected to the inter-frame encoding. Here, filter may not be applied.

If, as a result of the determination, the filter is determined to be applied to the reference pixel value, the encoder applies the filter to the reference pixel value at step S202. The applied filter may be a common filter. For example, the 3-tap filter of Equation 1 may be used, or a 2-tap filter may be used. When the 2-tap filter is used, various filter coefficients, such as  $(1/8, 7/8)$ ,  $(2/8, 6/8)$ , and  $(3/8, 5/8)$ , may be used. The reference pixel value to which the filter has been applied may be used when the filter is applied to other reference pixel values. Furthermore, when the filter is applied to the reference pixel value, the filter may be applied to all reference pixel values or only some of the reference pixel

values.

At step S203, the encoder performs intra-prediction on the basis of the reference pixel value to which the filter has been applied or to which the filter has not been applied.

At step S204, the encoder determines whether to apply the filter to a prediction value for each prediction mode, predicted by performing the intra-prediction, in order to encode a current block. Here, each prediction mode may be each of the 9 prediction modes in the  $4 \times 4$  luma prediction mode. When determining whether to apply the filter to a prediction value for each prediction mode, whether to apply the filter may be determined based on information about a surrounding block or according to the RDO method.

When determining whether to apply the filter to the prediction value based on the information about a surrounding block, a prediction mode of the current block may be determined based on prediction mode information (MPM) about the surrounding block, and whether to apply the filter to the prediction value may be determined based on the determined prediction mode of the current block. For example, assuming that a current block is 'C', an upper block is 'A', and a left block is 'B', when a prediction mode of the current block is the same as a prediction mode of the upper block 'A', the prediction mode of the upper block 'A' may be determined as the

prediction mode of the current block. When the prediction mode of the current block is same as a prediction mode of the left block 'B', the prediction mode of the left block 'B' may be determined as the prediction mode of the current block. Alternatively, when the prediction mode of the current block is a prediction mode other than the prediction mode of the upper block 'A' or the prediction mode of the left block 'B', a relevant prediction mode is encoded and transmitted. Here, when the prediction mode of the current block is a specific prediction mode (DC or planar), a difference between a reference pixel value and a prediction value may be relatively greater than that of other prediction modes. For example, a difference between a reference pixel value and a prediction value in the planar prediction mode may be relatively greater than that of other prediction modes. The prediction value in the planar prediction mode may be calculated by averaging a first prediction value, obtained by horizontally performing linear interpolation for each row, and a second prediction value obtained by vertically performing linear interpolation for each column. When the linear interpolation is horizontally performed, a right value is the same as a value placed at a right upward position (i.e., D in FIG. 3), from among the reference pixel values. When the linear interpolation is vertically performed, a downward value is the same as a value placed at a left downward

position (i.e., L in FIG. 3), from among the reference pixel values. Since the prediction value is not directly obtained from the reference pixel value, a difference between the reference pixel value and the prediction value may be relatively great. In this case, intra-prediction efficiency may be increased by applying the filter to the prediction value. Whether to apply the filter to the prediction value may be determined according to the prediction mode of the current block determined as described above. Even when a current block, an upper block, and a left block have different sizes, a prediction mode of the current block may be determined according to the prediction mode of a surrounding block.

Alternatively, whether to apply the filter to the prediction value may be determined according to the size of a current block besides the prediction mode of a current block. Here, whether to apply the filter according to the prediction mode of the current block and the size of the current block is previously designated, and whether to apply the filter is adaptively determined according to the relevant prediction mode or the relevant size. Alternatively, whether to apply the filter to the prediction value may be determined according to whether surrounding blocks have been subjected to intra-frame encoding or inter-frame encoding.

If, as a result of the determination, the filter is determined to have

been applied to the prediction value, the encoder applies the filter to the prediction value at step S205. Accordingly, the prediction of the current block is completed, and the encoder calculates a residual signal and performs entropy coding.

FIG. 7 is a diagram showing an example in which the filter is applied to the prediction value according to the proposed method of performing intra-prediction using the adaptive filter.

Referring to FIG. 7, in the case where the prediction mode of a current block is a non-directional mode, a difference between a reference pixel value and a prediction value may become relatively greater than that of other prediction modes. Accordingly, the filter may be applied to only the prediction values of pixels adjacent to the boundary with surrounding restored reference pixel values. For example, filtering may be performed for prediction values corresponding to a1~a8, and b1, c1, d1, e1, f1, g1, and h1 corresponding to the pixels of one line which is placed at the boundary in FIG. 7. Alternatively, filtering may be performed for prediction values corresponding to a1~a8, b1~b8, and c1~c2, d1~d2, e1~e2, f1~f2, g1~g2, and h1~h2 corresponding to the pixels of two lines which are placed at the boundary in FIG. 7. Here, the applied filter may be a common filter. For example, the 3-tap filter of Equation 1 may be used or a 2-tap filter may be



used. When the 2-tap filter is used, various filter coefficients, such as (1/8, 7/8), (2/8, 6/8), and (3/8, 5/8), may be used. Alternatively, any one of the 2-tap filter and the 3-tap filter may be selected and used according to the positions of pixels.

In the case where the prediction mode of a current block is a prediction mode using the reference pixel values corresponding to A~P as in the mode 0, the mode 3, or the mode 7 in this way, the filter may be applied to prediction values which correspond to a1~a8 having a relatively great difference between the reference pixel value and the prediction value. Furthermore, in the case where the prediction mode of a current block is a prediction mode using the reference pixel values corresponding to Q~X as in the mode 1 or the mode 8, the filter may be applied to prediction values which correspond to a1, b1, c1, d1, e1, f1, g1, and h1 having a relatively great difference between the reference pixel value and the prediction value

Equation 2 is an example of Equation, indicating the filter applied to prediction values when the 2-tap filter or the 3-tap filter is selected and used according to the positions of pixels.

<Equation 2>

$$f[a1] = (2 \times A + 4 \times a1 + 2 \times Q) / 8$$

$$f[b1] = (2 \times B + 6 \times b1) / 8$$

$$f[c1] = (2 \times C + 6 \times c1) / 8$$

...

$$f[a2] = (2 \times R + 6 \times a2) / 8$$

$$f[a3] = (2 \times S + 6 \times a3) / 8$$

...

In Equation 2,  $f[a1]$  is a value in which the filter is applied to the prediction value  $a1$ , and  $A$  and  $Q$  indicate the reference pixel values. From Equation 2, it can be seen that the 3-tap filter is applied to the prediction value of a pixel where the prediction value  $a1$  is placed, and the 2-tap filter is applied to the prediction values of remaining pixels.

Equation 3 is another example of Equation, indicating the filter applied to prediction values when the filter is applied to the prediction values according to the proposed method of performing intra-prediction using the adaptive filter.

<Equation 3>

1. Vertical low-pass filter

$$v[a1] = (A + 2 \times a1 + a2) / 4$$

$$v[a2] = (v[a1] + 2 \times a2 + a3) / 4$$

...

$$v[a8] = (v[a7] + 3 \times a8) / 4$$

$$v[b1] = (B + 2 \times b1 + b2)/4$$

...

2. Horizontal low-pass filter

$$h[a1] = (Q + 2 \times v[a1] + v[b1])/4$$

$$h[b1] = (h[a1] + 2 \times v[b1] + v[c1])/4$$

...

$$h[h1] = (h[g1] + 3 \times v[h1])/4$$

$$h[a2] = (R + 2 \times v[a2] + v[b2])/4$$

...

In Equation 3, the filter may be used when the adaptive filter is applied according to the method using information about surrounding blocks or the RDO method for each of the prediction modes. Referring to Equation 3, a low-pass filter having filter coefficients (1, 2, 1) is sequentially applied to two vertical and horizontal directions. First, the filter is applied to the vertical direction, and the filter is applied to the horizontal direction based on a prediction value to which the filter has been applied. The prediction value to which the filter has been applied may be used when the filter is applied to other prediction values.

Meanwhile, when the RDO method is used, the method of performing intra-prediction described with reference to FIG. 6 may be repeatedly performed.

FIG. 8 is a block diagram of an encoder and a decoder in which the embodiments of the present invention are implemented.

The encoder 800 includes a processor 810 and memory 820. The processor 810 implements the proposed functions, processes, and/or methods. The processor 810 is configured to determine whether to apply a first filter to reference pixel values based on information about surrounding blocks of a current block, apply the first filter to the reference pixel values if, as a result of the determination, the first filter is determined to be applied, perform intra-prediction for the current block on the basis of the reference pixel values, determine whether to apply a second filter to a prediction value for each prediction mode of the current block which has been predicted by performing the intra-prediction based on the information about surrounding blocks, and apply the second filter to the prediction value for each prediction mode of the current block if, as a result of the determination, the second filter is determined to be applied. The memory 820 is connected to the processor 810 and is configured to store various pieces of information for driving the processor 810.

The decoder 900 includes a processor 910 and memory 920. The processor 910 implements the proposed functions, processes, and/or methods. The processor 910 is configured to determine whether to apply a first filter to

reference pixel values based on information about surrounding blocks of a current block, apply the first filter to the reference pixel values if, as a result of the determination, the first filter is determined to be applied, perform intra-prediction for the current block on the basis of the reference pixel values, determine whether to apply a second filter to a prediction value for each prediction mode of the current block which has been predicted by performing the intra-prediction based on the information about surrounding blocks, and apply the second filter to the prediction value for each prediction mode of the current block if, as a result of the determination, the second filter is determined to be applied. The memory 920 is connected to the processor 910 and is configured to store various pieces of information for driving the processor 910.

The processor 810, 910 may include Application-Specific Integrated Circuits (ASICs), other chipsets, logic circuits, and/or data processors. The memory 820, 920 may include Read-Only Memory (ROM), Random Access Memory (RAM), flash memory, a memory card, a storage medium, and/or other storage devices. When the above embodiments are implemented in software, the above schemes may be implemented using a module (or a process or function) for performing the above functions. The module may be stored in the memory 820, 920 and may be executed by the processor 810, 910. The memory 820, 920 may

be internal or external to the processor 810, 910 and may be coupled to the processor 810, 910 using a variety of well-known means.

In the above-described exemplary systems, although the methods have been described on the basis of the flowcharts using a series of steps or blocks, the present invention is not limited to the sequence of the steps, and some of the steps may be performed at different sequences from the remaining steps or may be performed simultaneously with the remaining steps. Furthermore, those skilled in the art will understand that the steps shown in the flowcharts are not exclusive and other steps may be included or one or more steps of the flowcharts may be deleted without affecting the scope of the present invention.

The above-described embodiments include various aspects of illustrations. Although all kinds of possible combinations for representing the various aspects may not be described, a person having ordinary skill in the art will understand that other possible combinations are possible. Accordingly, the present invention may be said to include all other replacements, modifications, and changes belonging to the accompanying claims.

**【CLAIMS】****【Claim 1】**

A video decoding apparatus comprising:

a processor to determine whether to apply a first filter to a reference pixel value of a current block based on at least one of an intra prediction mode of the current block and a size of the current block,

apply the first filter to the reference pixel value if, as a result of the determination, the first filter is determined to be applied, and

perform intra-prediction for the current block based on the reference pixel value,

wherein when the first filter is determined to be applied, the processor calculates a difference the reference pixel values, compares the calculated difference with a specific threshold and applies the first filter to the reference pixel value based on comparison of the specific threshold and the calculated difference.

**【Claim 2】**

The video decoding apparatus of claim 1, when the intra-prediction for the current block is performed, the processor determines whether to apply a second filter to a prediction value of the current block based on at least one of the intra prediction mode of the current block and the size of the

current block, and applies the second filter to the prediction value of the current block if, as a result of the determination, the second filter is determined to be applied.

**【Claim 3】**

The video decoding apparatus of claim 2, wherein the first filter is at least any one of a 3-tap filter and a 2-tap filter and the second filter is at least any one of a 3-tap filter and a 2-tap filter.



**【ABSTRACT】**

Provided is a method and apparatus for performing intra-prediction using an adaptive filter. The method for performing intra-prediction comprises the steps of: determining whether or not to apply a first filter for a reference pixel value on the basis of information of a neighboring block of a current block; applying the first filter for the reference pixel value when it is determined to apply the first filter; performing intra-prediction on the current block on the basis of the reference pixel value; determining whether or not to apply a second filter for a prediction value according to each prediction mode of the current block, which is predicted by the intra-prediction performance on the basis of the information of the neighboring block; and applying the second filter for the prediction value according to each prediction mode of the current block when it is determined to apply the second filter.

FIG. 1

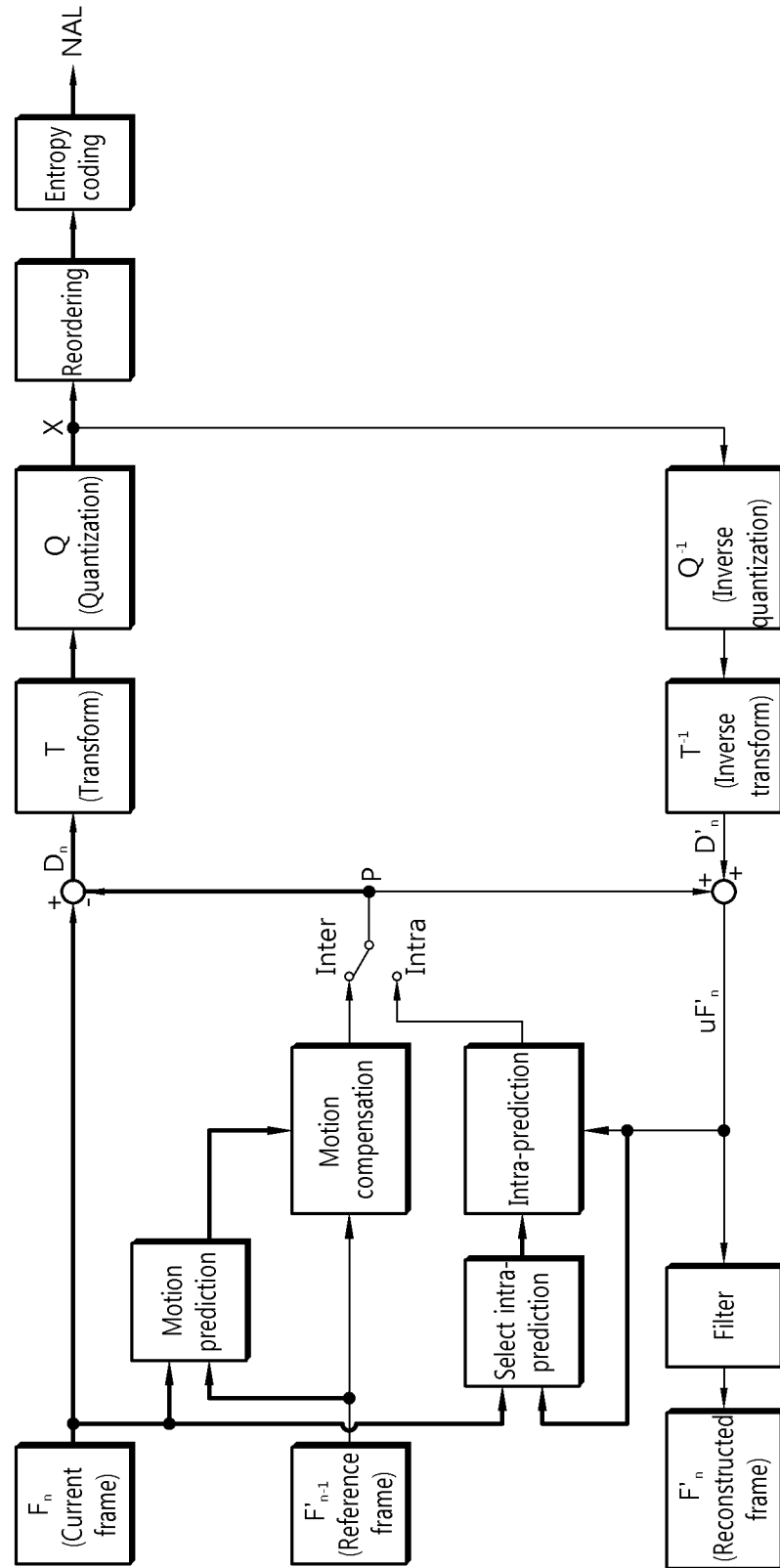

FIG. 2

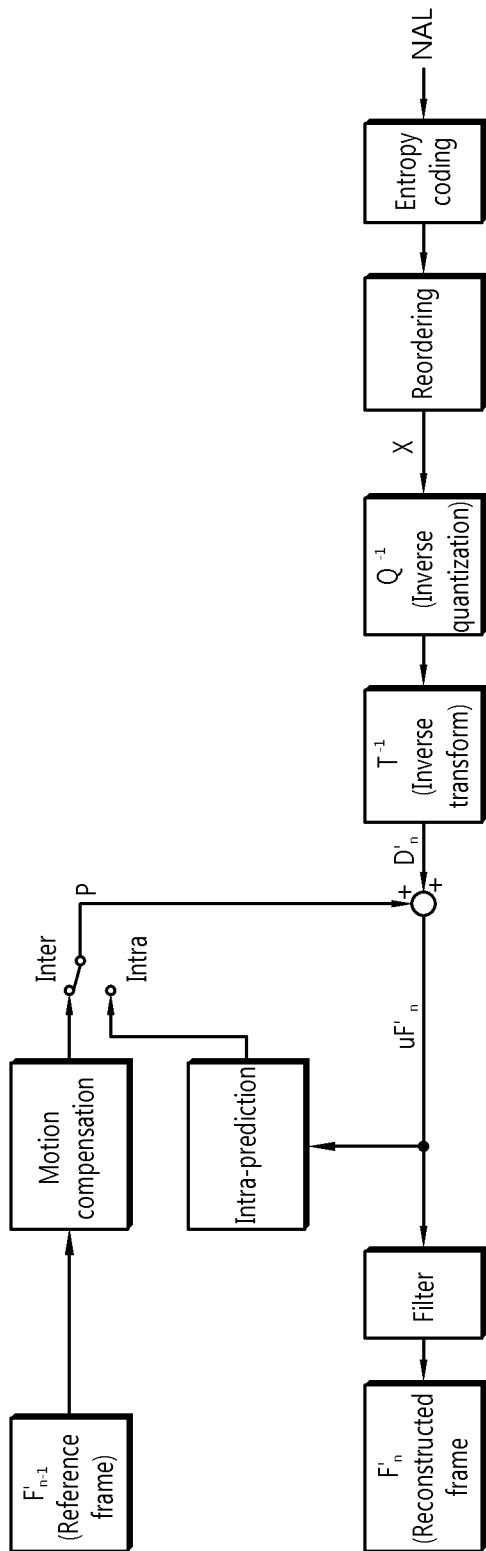

FIG. 3

M	A	B	C	D	E	F	G	H
I	a	b	c	d				
J	e	f	g	h				
K	i	j	k	l				
L	m	n	o	p				

FIG. 4

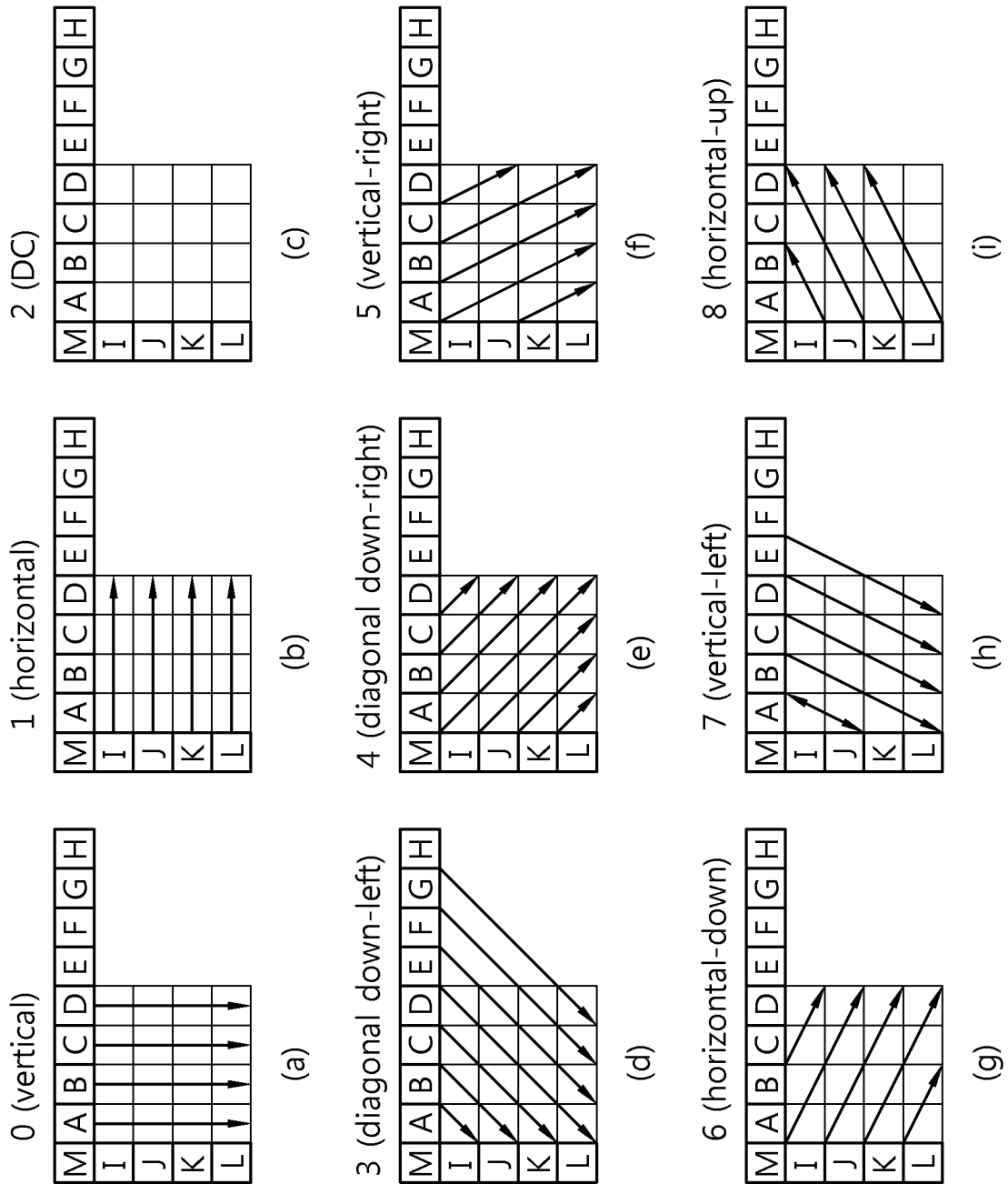

FIG. 5

Z	A	B	C	D	E	F	G	H	I	J	K	L	M	N	O	P
Q																
R																
S																
T																
U																
V																
W																
X																

FIG. 6

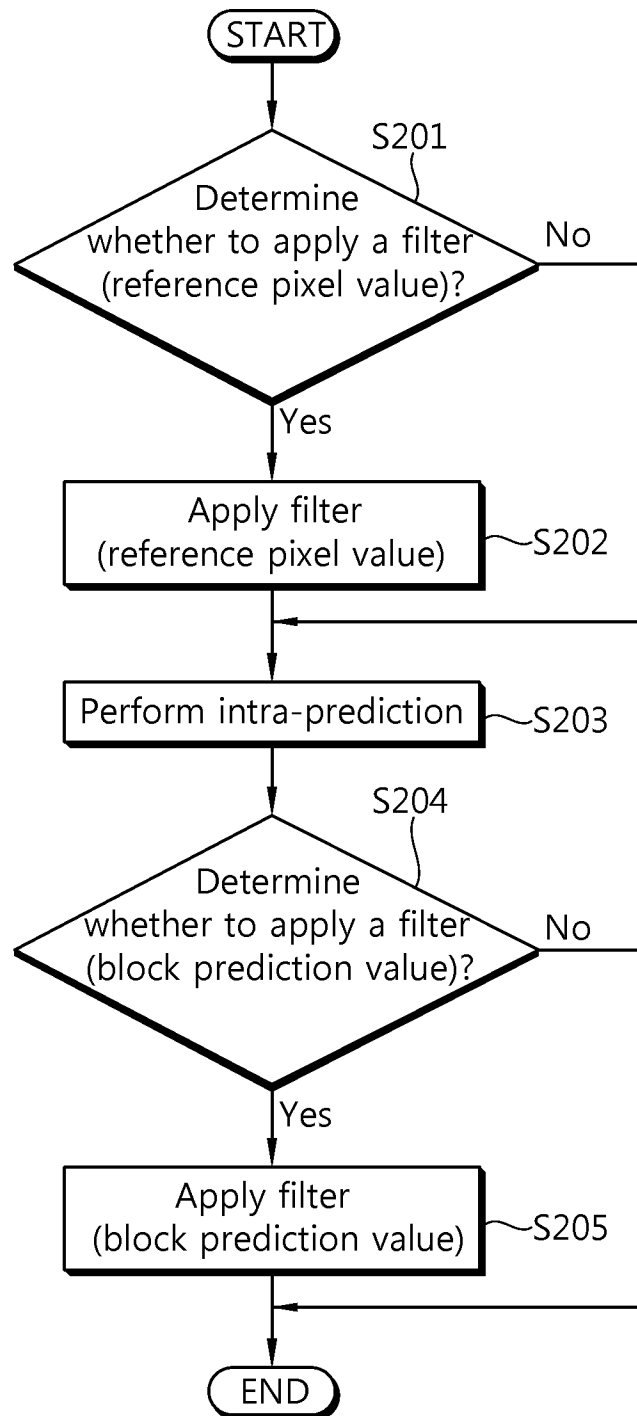

FIG. 7

Z	A	B	C	D	E	F	G	H	I	J	K	L	M	N	O	P
Q	a1	b1	c1	d1	e1	f1	g1	h1								
R	a2	b2	c2	d2	e2	f2	g2	h2								
S	a3	b3	...	...	...	...	...	...								
T	a4	b4	...	...	...	...	...	...								
U	a5	b5	...	...	...	...	...	...								
V	a6	b6	...	...	...	f6	g6	h6								
W	a7	b7	...	...	...	f7	g7	h7								
X	a8	b8	...	...	...	f8	g8	h8								



FIG. 8

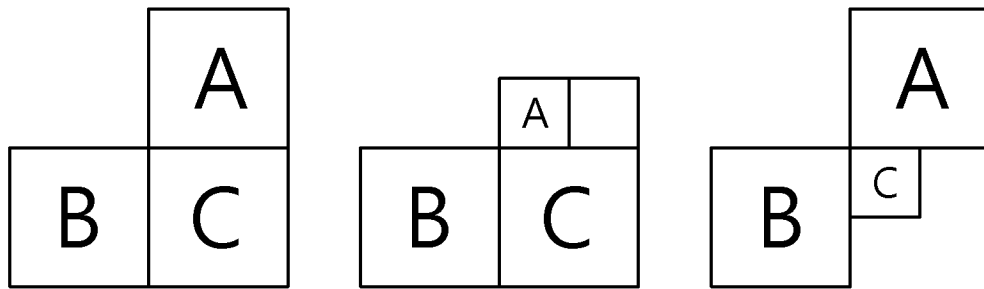
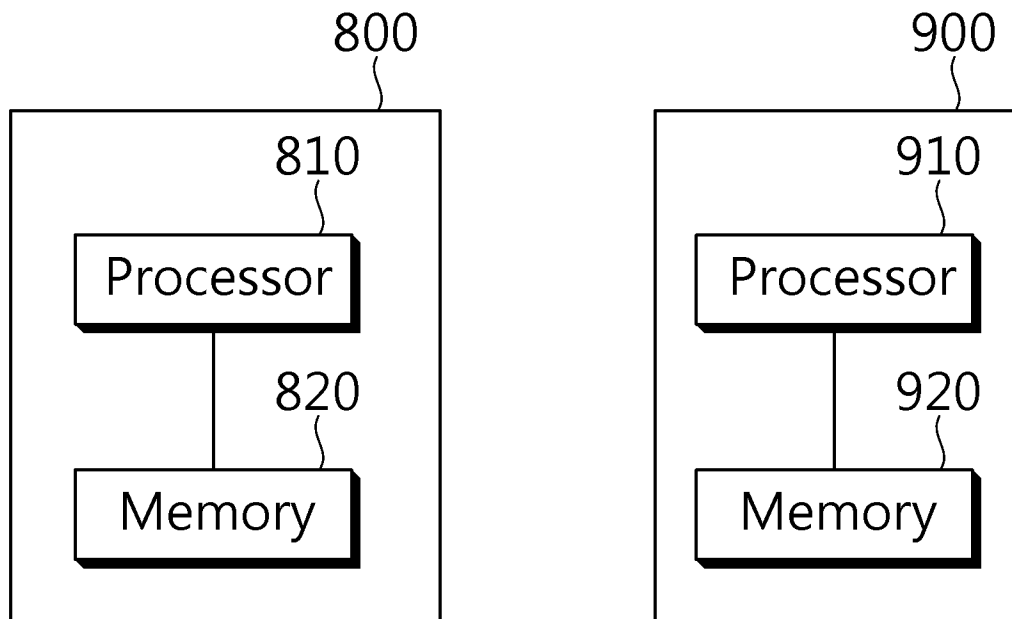

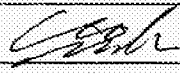
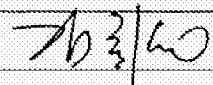
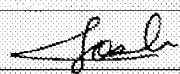
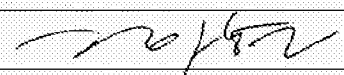

FIG. 9



**DECLARATION (37 CFR 1.63) FOR UTILITY OR DESIGN APPLICATION  
USING AN APPLICATION DATA SHEET (37 CFR 1.76) AND ASSIGNMENT**

<b>Title of Invention</b>	METHOD AND APPARATUS FOR PERFORMING INTRA-PREDICTION USING ADAPTIVE FILTER
<b>Declaration</b>	<p>As the below named inventor(s), I hereby declare that: The declaration is directed to:</p> <p><input checked="" type="checkbox"/> The attached application, or <input type="checkbox"/> United States application or PCT international application number <u>PCT/KR#####</u> filed on _____.</p> <p>The above-identified application was made or authorized to be made by me. I believe that I am the original or an original joint inventor of a claimed invention in the application. I hereby acknowledge that any willful false statement made in this declaration is punishable under 18 U.S.C. 1001 by fine or imprisonment of not more than five (5) years or both.</p>
<b>Assignment</b>	<p>NOW, THEREFORE, in consideration of the sum of one dollar (\$1), the receipt whereof is acknowledge, and other good and valuable consideration, I, by these presents do sell, assign and transfer unto said assignee(s)</p> <p align="center"><b>ELECTRONICS AND TELECOMMUNICATIONS RESEARCH INSTITUTE</b></p> <p>and the heirs, successors, assigns and legal representatives of the assignee(s) the full and exclusive right to the said invention in the United States and in its territorial possessions and in any and all foreign countries any and all improvements thereof, the entire rights, title and interest in and to any and all Patents which may be granted therefore in the United States. I hereby authorize and request the Director of the U.S. Patent and Trademark Office to issue said United States Patent to said assignee(s), of the entire right, title, and interest in and to the same, for his sole use and for the use of his legal representatives, to the full end of the term for which said Patent may be granted, as fully and entirely as the same would have been held by me had this assignment and sale not been made.</p> <p>I agree promptly upon request of the assignee(s), its heirs, successors, assigns and legal representatives of the assignee(s) to communicate any facts known to it respecting the patent and the invention set forth therein, and to execute and deliver without further compensation any power of attorney, Assignment application, whether original, continuation, divisional or reissue, or other papers that may be necessary.</p> <p>I hereby covenant that no assignment, sale agreement or encumbrance has been or will be made or entered into which would conflict with this assignment and sale.</p> <p>I further covenant that assignee(s) will, upon its request, be provided promptly with all pertinent facts and documents relating to said invention and said Letters Patent and legal equivalents as may be known and accessible to me and will testify as to the same in any litigation related thereto and will promptly execute and deliver to assignee(s) or its legal representatives any and all papers, instruments or affidavits required to apply for, obtain, maintain, issue and enforce said application, said invention and said Letters Patent and said equivalents thereof which may be necessary or desirable to carry out the purposes thereof.</p>

**DECLARATION (37 CFR 1.63) FOR UTILITY OR DESIGN APPLICATION  
USING AN APPLICATION DATA SHEET (37 CFR 1.76) AND ASSIGNMENT**

Legal Name Of Inventor	Inventor Name (First Middle LAST):	Jin Ho LEE
	Inventor Signature:	
	Date:	Jul. 24. 2015
Legal Name Of Joint Inventor, If Any	Inventor Name (First Middle LAST):	Hui Yong KIM
	Inventor Signature:	
	Date:	Jul. 24. 2015
Legal Name Of Joint Inventor, If Any	Inventor Name (First Middle LAST):	Se Yoon JEONG
	Inventor Signature:	
	Date:	
Legal Name Of Joint Inventor, If Any	Inventor Name (First Middle LAST):	Suk Hee CHO
	Inventor Signature:	
	Date:	Jul. 24. 2015
Legal Name Of Joint Inventor, If Any	Inventor Name (First Middle LAST):	Ha Hyun LEE
	Inventor Signature:	
	Date:	Jul. 24. 2015
Legal Name Of Joint Inventor, If Any	Inventor Name (First Middle LAST):	Jong Ho KIM
	Inventor Signature:	
	Date:	Jul. 24, 2015
Legal Name Of Joint Inventor, If Any	Inventor Name (First Middle LAST):	Sung Chang LIM
	Inventor Signature:	
	Date:	Jul. 24, 2015

**DECLARATION (37 CFR 1.63) FOR UTILITY OR DESIGN APPLICATION  
USING AN APPLICATION DATA SHEET (37 CFR 1.76) AND ASSIGNMENT**

Legal Name Of Joint Inventor, If Any	Inventor Name (First Middle LAST):	Jin Soo CHOI
	Inventor Signature:	
	Date:	July 27, 2015

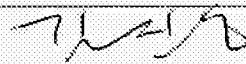
Legal Name Of Joint Inventor, If Any	Inventor Name (First Middle LAST):	Jin Woong KIM
	Inventor Signature:	
	Date:	July 27, 2015.

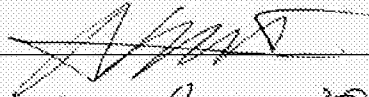
Legal Name Of Joint Inventor, If Any	Inventor Name (First Middle LAST):	Chie Teuk AHN
	Inventor Signature:	
	Date:	10, Aug 2015

**DECLARATION (37 CFR 1.63) FOR UTILITY OR DESIGN APPLICATION  
USING AN APPLICATION DATA SHEET (37 CFR 1.76) AND ASSIGNMENT**

<b>Title of Invention</b>	METHOD AND APPARATUS FOR PERFORMING INTRA-PREDICTION USING ADAPTIVE FILTER
<b>Declaration</b>	<p>As the below named inventor(s), I hereby declare that: The declaration is directed to:</p> <p><input checked="" type="checkbox"/> The attached application, or <input type="checkbox"/> United States application or PCT international application number <b>PCT/KR#####</b> filed on _____ .</p> <p>The above-identified application was made or authorized to be made by me. I believe that I am the original or an original joint inventor of a claimed invention in the application. I hereby acknowledge that any willful false statement made in this declaration is punishable under 18 U.S.C. 1001 by fine or imprisonment of not more than five (5) years or both.</p>
<b>Assignment</b>	<p>NOW, THEREFORE, in consideration of the sum of one dollar (\$1), the receipt whereof is acknowledge, and other good and valuable consideration, I, by these presents do sell, assign and transfer unto said assignee(s)</p> <p align="center"><b>ELECTRONICS AND TELECOMMUNICATIONS RESEARCH INSTITUTE</b></p> <p>and the heirs, successors, assigns and legal representatives of the assignee(s) the full and exclusive right to the said invention in the United States and in its territorial possessions and in any and all foreign countries any and all improvements thereof, the entire rights, title and interest in and to any and all Patents which may be granted therefore in the United States. I hereby authorize and request the Director of the U.S. Patent and Trademark Office to issue said United States Patent to said assignee(s), of the entire right, title, and interest in and to the same, for his sole use and for the use of his legal representatives, to the full end of the term for which said Patent may be granted, as fully and entirely as the same would have been held by me had this assignment and sale not been made.</p> <p>I agree promptly upon request of the assignee(s), its heirs, successors, assigns and legal representatives of the assignee(s) to communicate any facts known to it respecting the patent and the invention set forth therein, and to execute and deliver without further compensation any power of attorney, Assignment, application, whether original, continuation, divisional or reissue, or other papers that may be necessary.</p> <p>I hereby covenant that no assignment, sale agreement or encumbrance has been or will be made or entered into which would conflict with this assignment and sale.</p> <p>I further covenant that assignee(s) will, upon its request, be provided promptly with all pertinent facts and documents relating to said invention and said Letters Patent and legal equivalents as may be known and accessible to me and will testify as to the same in any litigation related thereto and will promptly execute and deliver to assignee(s) or its legal representatives any and all papers, instruments or affidavits required to apply for, obtain, maintain, issue and enforce said application, said invention and said Letters Patent and said equivalents thereof which may be necessary or desirable to carry out the purposes thereof.</p>

**DECLARATION (37 CFR 1.63) FOR UTILITY OR DESIGN APPLICATION  
USING AN APPLICATION DATA SHEET (37 CFR 1.76) AND ASSIGNMENT**

<b>Legal Name Of Inventor</b>	Inventor Name (First Middle LAST):	Jin Ho LEE
	Inventor Signature:	
	Date:	

<b>Legal Name Of Joint Inventor, If Any</b>	Inventor Name (First Middle LAST):	Hui Yong KIM
	Inventor Signature:	
	Date:	

<b>Legal Name Of Joint Inventor, If Any</b>	Inventor Name (First Middle LAST):	Se Yoon JEONG
	Inventor Signature:	<i>Se Yoon Jeong</i>
	Date:	<i>Aug - 3. 2015</i>

<b>Legal Name Of Joint Inventor, If Any</b>	Inventor Name (First Middle LAST):	Suk Hee CHO
	Inventor Signature:	
	Date:	

<b>Legal Name Of Joint Inventor, If Any</b>	Inventor Name (First Middle LAST):	Ha Hyun LEE
	Inventor Signature:	
	Date:	

<b>Legal Name Of Joint Inventor, If Any</b>	Inventor Name (First Middle LAST):	Jong Ho KIM
	Inventor Signature:	
	Date:	

<b>Legal Name Of Joint Inventor, If Any</b>	Inventor Name (First Middle LAST):	Sung Chang LIM
	Inventor Signature:	
	Date:	

<b>DECLARATION (37 CFR 1.63) FOR UTILITY OR DESIGN APPLICATION USING AN APPLICATION DATA SHEET (37 CFR 1.76) AND ASSIGNMENT</b>
---

<b>Legal Name Of Joint Inventor, If Any</b>	Inventor Name (First Middle LAST):	Jin Soo CHOI
	Inventor Signature:	
	Date:	

<b>Legal Name Of Joint Inventor, If Any</b>	Inventor Name (First Middle LAST):	Jin Woong KIM
	Inventor Signature:	
	Date:	

<b>Legal Name Of Joint Inventor, If Any</b>	Inventor Name (First Middle LAST):	Chie Teuk AHN
	Inventor Signature:	
	Date:	



Under the Paperwork Reduction Act of 1995, no persons are required to respond to a collection of information unless it contains a valid OMB control number.

<b>Application Data Sheet 37 CFR 1.76</b>		Attorney Docket Number	PA0929-2C
		Application Number	
Title of Invention	METHOD AND APPARATUS FOR PERFORMING INTRA-PREDICTION USING ADAPTIVE FILTER		
<p>The application data sheet is part of the provisional or nonprovisional application for which it is being submitted. The following form contains the bibliographic data arranged in a format specified by the United States Patent and Trademark Office as outlined in 37 CFR 1.76. This document may be completed electronically and submitted to the Office in electronic format using the Electronic Filing System (EFS) or the document may be printed and included in a paper filed application.</p>			

**Secrecy Order 37 CFR 5.2**

<input type="checkbox"/> Portions or all of the application associated with this Application Data Sheet may fall under a Secrecy Order pursuant to 37 CFR 5.2 (Paper filers only. Applications that fall under Secrecy Order may not be filed electronically.)
--

**Inventor Information:**

<b>Inventor 1</b>					<input type="button" value="Remove"/>
<b>Legal Name</b>					
<b>Prefix</b>	<b>Given Name</b>	<b>Middle Name</b>	<b>Family Name</b>	<b>Suffix</b>	
	Jin Ho		LEE		
<b>Residence Information (Select One)</b> <input type="radio"/> US Residency <input checked="" type="radio"/> Non US Residency <input type="radio"/> Active US Military Service					
<b>City</b>	Daejeon-si	<b>Country of Residence</b>			KR
<b>Mailing Address of Inventor:</b>					
<b>Address 1</b>	313-1102 Youngbangmaeul Apt., Yongun-dong,				
<b>Address 2</b>	Dong-gu				
<b>City</b>	Daejeon-si	<b>State/Province</b>			
<b>Postal Code</b>		<b>Country</b>		KR	
<b>Inventor 2</b>					<input type="button" value="Remove"/>
<b>Legal Name</b>					
<b>Prefix</b>	<b>Given Name</b>	<b>Middle Name</b>	<b>Family Name</b>	<b>Suffix</b>	
	Hui Yong		KIM		
<b>Residence Information (Select One)</b> <input type="radio"/> US Residency <input checked="" type="radio"/> Non US Residency <input type="radio"/> Active US Military Service					
<b>City</b>	Daejeon-si	<b>Country of Residence</b>			KR
<b>Mailing Address of Inventor:</b>					
<b>Address 1</b>	601-201 Yeolmaeaeul Apt., Jijok-dong, Yuseong-gu				
<b>Address 2</b>					
<b>City</b>	Daejeon-si	<b>State/Province</b>			
<b>Postal Code</b>		<b>Country</b>		KR	
<b>Inventor 3</b>					<input type="button" value="Remove"/>
<b>Legal Name</b>					

Under the Paperwork Reduction Act of 1995, no persons are required to respond to a collection of information unless it contains a valid OMB control number.

<b>Application Data Sheet 37 CFR 1.76</b>		Attorney Docket Number	PA0929-2C
		Application Number	
Title of Invention	METHOD AND APPARATUS FOR PERFORMING INTRA-PREDICTION USING ADAPTIVE FILTER		

Prefix	Given Name	Middle Name	Family Name	Suffix
	Se Yoon		JEONG	
<b>Residence Information (Select One)</b> <input type="radio"/> US Residency <input checked="" type="radio"/> Non US Residency <input type="radio"/> Active US Military Service				
City	Daejeon-si	Country of Residence	;	KR

<b>Mailing Address of Inventor:</b>				
Address 1	101-1203 Geumseong Baekjo Apt., Birae-dong,			
Address 2	Daedeok-gu			
City	Daejeon-si	State/Province		
Postal Code		Country	;	KR
Inventor	4			<input type="button" value="Remove"/>

<b>Legal Name</b>				
Prefix	Given Name	Middle Name	Family Name	Suffix
	Suk Hee		CHO	
<b>Residence Information (Select One)</b> <input type="radio"/> US Residency <input checked="" type="radio"/> Non US Residency <input type="radio"/> Active US Military Service				
City	Daejeon-si	Country of Residence	;	KR

<b>Mailing Address of Inventor:</b>				
Address 1	103-802 Humansia Apt., Bongsan-dong, Yuseong-gu			
Address 2				
City	Daejeon-si	State/Province		
Postal Code		Country	;	KR
Inventor	5			<input type="button" value="Remove"/>

<b>Legal Name</b>				
Prefix	Given Name	Middle Name	Family Name	Suffix
	Ha Hyun		LEE	
<b>Residence Information (Select One)</b> <input type="radio"/> US Residency <input checked="" type="radio"/> Non US Residency <input type="radio"/> Active US Military Service				
City	Seoul	Country of Residence	;	KR

<b>Mailing Address of Inventor:</b>				
Address 1	136-5 Myeonmok 2-dong, Jungnang-gu			
Address 2				
City	Seoul	State/Province		
Postal Code		Country	;	KR

IPR2021-00827

<b>Application Data Sheet 37 CFR 1.76</b>		Attorney Docket Number	PA0929-2C
		Application Number	
Title of Invention	METHOD AND APPARATUS FOR PERFORMING INTRA-PREDICTION USING ADAPTIVE FILTER		

<b>Inventor 6</b>					<a href="#">Remove</a>
<b>Legal Name</b>					
<b>Prefix</b>	<b>Given Name</b>	<b>Middle Name</b>	<b>Family Name</b>	<b>Suffix</b>	
	Jong Ho		KIM		
<b>Residence Information (Select One)</b> <input type="radio"/> US Residency <input checked="" type="radio"/> Non US Residency <input type="radio"/> Active US Military Service					
<b>City</b>	Daejeon-si	<b>Country of Residence</b>	i	KR	

<b>Mailing Address of Inventor:</b>					
<b>Address 1</b>	Rm. 205 Finehouse, 146-8 Sinseong-dong,				
<b>Address 2</b>	Yuseong-gu				
<b>City</b>	Daejeon-si	<b>State/Province</b>			
<b>Postal Code</b>		<b>Country</b>	i	KR	

<b>Inventor 7</b>					<a href="#">Remove</a>
<b>Legal Name</b>					
<b>Prefix</b>	<b>Given Name</b>	<b>Middle Name</b>	<b>Family Name</b>	<b>Suffix</b>	
	Sung Chang		LIM		
<b>Residence Information (Select One)</b> <input type="radio"/> US Residency <input checked="" type="radio"/> Non US Residency <input type="radio"/> Active US Military Service					
<b>City</b>	Daejeon-si	<b>Country of Residence</b>	i	KR	

<b>Mailing Address of Inventor:</b>					
<b>Address 1</b>	Rm. 201 Sejongvilla, 254-8 Sinseong-dong,				
<b>Address 2</b>	Yuseong-gu				
<b>City</b>	Daejeon-si	<b>State/Province</b>			
<b>Postal Code</b>		<b>Country</b>	i	KR	

<b>Inventor 8</b>					<a href="#">Remove</a>
<b>Legal Name</b>					
<b>Prefix</b>	<b>Given Name</b>	<b>Middle Name</b>	<b>Family Name</b>	<b>Suffix</b>	
	Jin Soo		CHOI		
<b>Residence Information (Select One)</b> <input type="radio"/> US Residency <input checked="" type="radio"/> Non US Residency <input type="radio"/> Active US Military Service					
<b>City</b>	Daejeon-si	<b>Country of Residence</b>	i	KR	

<b>Mailing Address of Inventor:</b>					
<b>Address 1</b>	609-1605 Banseokmaeul 6 Danji Apt., 613				
<b>Address 2</b>	Banseok-dong, Yuseong-gu				
IPR2021-00827					

Under the Paperwork Reduction Act of 1995, no persons are required to respond to a collection of information unless it contains a valid OMB control number.

<b>Application Data Sheet 37 CFR 1.76</b>		Attorney Docket Number	PA0929-2C
		Application Number	
Title of Invention	METHOD AND APPARATUS FOR PERFORMING INTRA-PREDICTION USING ADAPTIVE FILTER		

City	Daejeon-si	State/Province	
Postal Code		Country	KR
Inventor	9	<input type="button" value="Remove"/>	
Legal Name			
Prefix	Given Name	Middle Name	Family Name
	Jin Woong		KIM
Residence Information (Select One) <input type="radio"/> US Residency <input checked="" type="radio"/> Non US Residency <input type="radio"/> Active US Military Service			
City	Daejeon-si	Country of Residence	KR

<b>Mailing Address of Inventor:</b>			
Address 1	305-1603 Expo Apt., Jeonmin-dong, Yuseong-gu		
Address 2			
City	Daejeon-si	State/Province	
Postal Code		Country	KR
Inventor	10	<input type="button" value="Remove"/>	
Legal Name			
Prefix	Given Name	Middle Name	Family Name
	Chie Teuk		AHN
Residence Information (Select One) <input type="radio"/> US Residency <input checked="" type="radio"/> Non US Residency <input type="radio"/> Active US Military Service			
City	Daejeon-si	Country of Residence	KR

<b>Mailing Address of Inventor:</b>			
Address 1	2-504 KAIST Apt., Doryong-dong, Yuseong-gu		
Address 2			
City	Daejeon-si	State/Province	
Postal Code		Country	KR
All Inventors Must Be Listed - Additional Inventor Information blocks may be generated within this form by selecting the <b>Add</b> button. <span style="float: right;"><input type="button" value="Add"/></span>			

**Correspondence Information:**

Enter either Customer Number or complete the Correspondence Information section below. For further information see 37 CFR 1.33(a).	
<input type="checkbox"/> An Address is being provided for the correspondence information of this application.	
Customer Number	96767
Email Address	uspto.actions@wpapat.com <span style="float: right;"><input type="button" value="Add Email"/> <input type="button" value="Remove Email"/></span>

IPR2021-00827

Unified EX1002 Page 1156

<b>Application Data Sheet 37 CFR 1.76</b>	Attorney Docket Number	PA0929-2C
	Application Number	
Title of Invention	METHOD AND APPARATUS FOR PERFORMING INTRA-PREDICTION USING ADAPTIVE FILTER	

**Application Information:**

<b>Title of the Invention</b>	METHOD AND APPARATUS FOR PERFORMING INTRA-PREDICTION USING ADAPTIVE FILTER		
<b>Attorney Docket Number</b>	PA0929-2C	<b>Small Entity Status Claimed</b>	<input checked="" type="checkbox"/>
<b>Application Type</b>	Nonprovisional		
<b>Subject Matter</b>	Utility		
<b>Suggested Class (if any)</b>		<b>Sub Class (if any)</b>	
<b>Suggested Technology Center (if any)</b>			
<b>Total Number of Drawing Sheets (if any)</b>	9	<b>Suggested Figure for Publication (if any)</b>	

**Publication Information:**

<input type="checkbox"/>	Request Early Publication (Fee required at time of Request 37 CFR 1.219)
<input type="checkbox"/>	<b>Request Not to Publish.</b> I hereby request that the attached application not be published under 35 U.S.C. 122(b) and certify that the invention disclosed in the attached application <b>has not and will not</b> be the subject of an application filed in another country, or under a multilateral international agreement, that requires publication at eighteen months after filing.

**Representative Information:**

<p>Representative information should be provided for all practitioners having a power of attorney in the application. Providing this information in the Application Data Sheet does not constitute a power of attorney in the application (see 37 CFR 1.32). Either enter Customer Number or complete the Representative Name section below. If both sections are completed the customer Number will be used for the Representative Information during processing.</p>			
Please Select One:	<input checked="" type="radio"/> Customer Number	<input type="radio"/> US Patent Practitioner	<input type="radio"/> Limited Recognition (37 CFR 11.9)
Customer Number	96767		

**Domestic Benefit/National Stage Information:**

<p>This section allows for the applicant to either claim benefit under 35 U.S.C. 119(e), 120, 121, or 365(c) or indicate National Stage entry from a PCT application. Providing this information in the application data sheet constitutes the specific reference required by 35 U.S.C. 119(e) or 120, and 37 CFR 1.78.</p>			
Prior Application Status	Pending	<a href="#">Remove</a>	
Application Number	Continuity Type	Prior Application Number	Filing Date (YYYY-MM-DD)
	Continuation of	13640014	2012-10-08
<p>Additional Domestic Benefit/National Stage Data may be generated within this form by selecting the <b>Add</b> button.</p>			<a href="#">Add</a>

**Foreign Priority Information:**

Under the Paperwork Reduction Act of 1995, no persons are required to respond to a collection of information unless it contains a valid OMB control number.

<b>Application Data Sheet 37 CFR 1.76</b>	Attorney Docket Number	PA0929-2C
	Application Number	
Title of Invention	METHOD AND APPARATUS FOR PERFORMING INTRA-PREDICTION USING ADAPTIVE FILTER	

This section allows for the applicant to claim benefit of foreign priority and to identify any prior foreign application for which priority is not claimed. Providing this information in the application data sheet constitutes the claim for priority as required by 35 U.S.C. 119(b) and 37 CFR 1.55(a).

Remove			
Application Number	Country <sup>i</sup>	Filing Date (YYYY-MM-DD)	Priority Claimed
10-2010-0032778	KR	2010-04-09	<input checked="" type="radio"/> Yes <input type="radio"/> No
Remove			
Application Number	Country <sup>i</sup>	Filing Date (YYYY-MM-DD)	Priority Claimed
10-2011-0026079	KR	2011-03-23	<input checked="" type="radio"/> Yes <input type="radio"/> No
Remove			
Application Number	Country <sup>i</sup>	Filing Date (YYYY-MM-DD)	Priority Claimed
10-2011-0032766	KR	2011-04-08	<input checked="" type="radio"/> Yes <input type="radio"/> No
Additional Foreign Priority Data may be generated within this form by selecting the <b>Add</b> button.			Add

## Authorization to Permit Access:

<input checked="" type="checkbox"/> Authorization to Permit Access to the Instant Application by the Participating Offices
<p>If checked, the undersigned hereby grants the USPTO authority to provide the European Patent Office (EPO), the Japan Patent Office (JPO), the Korean Intellectual Property Office (KIPO), the World Intellectual Property Office (WIPO), and any other intellectual property offices in which a foreign application claiming priority to the instant patent application is filed access to the instant patent application. See 37 CFR 1.14(c) and (h). This box should not be checked if the applicant does not wish the EPO, JPO, KIPO, WIPO, or other intellectual property office in which a foreign application claiming priority to the instant patent application is filed to have access to the instant patent application.</p> <p>In accordance with 37 CFR 1.14(h)(3), access will be provided to a copy of the instant patent application with respect to: 1) the instant patent application-as-filed; 2) any foreign application to which the instant patent application claims priority under 35 U.S.C. 119(a)-(d) if a copy of the foreign application that satisfies the certified copy requirement of 37 CFR 1.55 has been filed in the instant patent application; and 3) any U.S. application-as-filed from which benefit is sought in the instant patent application.</p> <p>In accordance with 37 CFR 1.14(c), access may be provided to information concerning the date of filing this Authorization.</p>

## Applicant Information:

Providing assignment information in this section does not substitute for compliance with any requirement of part 3 of Title 37 of CFR to have an assignment recorded by the Office.
---

Under the Paperwork Reduction Act of 1995, no persons are required to respond to a collection of information unless it contains a valid OMB control number.

<b>Application Data Sheet 37 CFR 1.76</b>	Attorney Docket Number	PA0929-2C
	Application Number	
Title of Invention	METHOD AND APPARATUS FOR PERFORMING INTRA-PREDICTION USING ADAPTIVE FILTER	

<b>Applicant 1</b>			
If the applicant is the inventor (or the remaining joint inventor or inventors under 37 CFR 1.45), this section should not be completed. The information to be provided in this section is the name and address of the legal representative who is the applicant under 37 CFR 1.43; or the name and address of the assignee, person to whom the inventor is under an obligation to assign the invention, or person who otherwise shows sufficient proprietary interest in the matter who is the applicant under 37 CFR 1.46. If the applicant is an applicant under 37 CFR 1.46 (assignee, person to whom the inventor is obligated to assign, or person who otherwise shows sufficient proprietary interest) together with one or more joint inventors, then the joint inventor or inventors who are also the applicant should be identified in this section.			
<input type="button" value="Remove"/>			
<input checked="" type="radio"/> Assignee	<input type="radio"/> Legal Representative under 35 U.S.C. 117		
<input type="radio"/> Person to whom the inventor is obligated to assign.	<input type="radio"/> Person who shows sufficient proprietary interest		
If applicant is the legal representative, indicate the authority to file the patent application, the inventor is:			
Name of the Deceased or Legally Incapacitated Inventor : <input type="text"/>			
If the Assignee is an Organization check here. <input checked="" type="checkbox"/>			
Organization Name	Electronics and Telecommunications Research Institute		
<b>Mailing Address Information:</b>			
Address 1	218, Gajeong-ro, Yuseong-gu		
Address 2			
City	Daejeon	State/Province	
Country <sup>i</sup>	KR	Postal Code	
Phone Number		Fax Number	
Email Address			
Additional Applicant Data may be generated within this form by selecting the Add button. <input type="button" value="Add"/>			

**Signature:**

NOTE: This form must be signed in accordance with 37 CFR 1.33. See 37 CFR 1.4 for signature requirements and certifications					
Signature	/Woochoon W. Park/			Date (YYYY-MM-DD)	2015-08-13
First Name	Woochoon W.	Last Name	Park	Registration Number	55523
Additional Signature may be generated within this form by selecting the Add button. <input type="button" value="Add"/>					

Under the Paperwork Reduction Act of 1995, no persons are required to respond to a collection of information unless it contains a valid OMB control number.

<b>Application Data Sheet 37 CFR 1.76</b>	Attorney Docket Number	PA0929-2C
	Application Number	
Title of Invention	METHOD AND APPARATUS FOR PERFORMING INTRA-PREDICTION USING ADAPTIVE FILTER	

This collection of information is required by 37 CFR 1.76. The information is required to obtain or retain a benefit by the public which is to file (and by the USPTO to process) an application. Confidentiality is governed by 35 U.S.C. 122 and 37 CFR 1.14. This collection is estimated to take 23 minutes to complete, including gathering, preparing, and submitting the completed application data sheet form to the USPTO. Time will vary depending upon the individual case. Any comments on the amount of time you require to complete this form and/or suggestions for reducing this burden, should be sent to the Chief Information Officer, U.S. Patent and Trademark Office, U.S. Department of Commerce, P.O. Box 1450, Alexandria, VA 22313-1450. DO NOT SEND FEES OR COMPLETED FORMS TO THIS ADDRESS. **SEND TO: Commissioner for Patents, P.O. Box 1450, Alexandria, VA 22313-1450.**



## Privacy Act Statement

The Privacy Act of 1974 (P.L. 93-579) requires that you be given certain information in connection with your submission of the attached form related to a patent application or patent. Accordingly, pursuant to the requirements of the Act, please be advised that: (1) the general authority for the collection of this information is 35 U.S.C. 2(b)(2); (2) furnishing of the information solicited is voluntary; and (3) the principal purpose for which the information is used by the U.S. Patent and Trademark Office is to process and/or examine your submission related to a patent application or patent. If you do not furnish the requested information, the U.S. Patent and Trademark Office may not be able to process and/or examine your submission, which may result in termination of proceedings or abandonment of the application or expiration of the patent.

The information provided by you in this form will be subject to the following routine uses:

1. The information on this form will be treated confidentially to the extent allowed under the Freedom of Information Act (5 U.S.C. 552) and the Privacy Act (5 U.S.C. 552a). Records from this system of records may be disclosed to the Department of Justice to determine whether the Freedom of Information Act requires disclosure of these records.
2. A record from this system of records may be disclosed, as a routine use, in the course of presenting evidence to a court, magistrate, or administrative tribunal, including disclosures to opposing counsel in the course of settlement negotiations.
3. A record in this system of records may be disclosed, as a routine use, to a Member of Congress submitting a request involving an individual, to whom the record pertains, when the individual has requested assistance from the Member with respect to the subject matter of the record.
4. A record in this system of records may be disclosed, as a routine use, to a contractor of the Agency having need for the information in order to perform a contract. Recipients of information shall be required to comply with the requirements of the Privacy Act of 1974, as amended, pursuant to 5 U.S.C. 552a(m).
5. A record related to an International Application filed under the Patent Cooperation Treaty in this system of records may be disclosed, as a routine use, to the International Bureau of the World Intellectual Property Organization, pursuant to the Patent Cooperation Treaty.
6. A record in this system of records may be disclosed, as a routine use, to another federal agency for purposes of National Security review (35 U.S.C. 181) and for review pursuant to the Atomic Energy Act (42 U.S.C. 218(c)).
7. A record from this system of records may be disclosed, as a routine use, to the Administrator, General Services, or his/her designee, during an inspection of records conducted by GSA as part of that agency's responsibility to recommend improvements in records management practices and programs, under authority of 44 U.S.C. 2904 and 2906. Such disclosure shall be made in accordance with the GSA regulations governing inspection of records for this purpose, and any other relevant (i.e., GSA or Commerce) directive. Such disclosure shall not be used to make determinations about individuals.
8. A record from this system of records may be disclosed, as a routine use, to the public after either publication of the application pursuant to 35 U.S.C. 122(b) or issuance of a patent pursuant to 35 U.S.C. 151. Further, a record may be disclosed, subject to the limitations of 37 CFR 1.14, as a routine use, to the public if the record was filed in an application which became abandoned or in which the proceedings were terminated and which application is referenced by either a published application, an application open to public inspections or an issued patent.
9. A record from this system of records may be disclosed, as a routine use, to a Federal, State, or local law enforcement agency, if the USPTO becomes aware of a violation or potential violation of law or regulation.

# PATENT ASSIGNMENT COVER SHEET

Electronic Version v1.1  
 Stylesheet Version v1.2

EPAS ID: PAT3482712

<b>SUBMISSION TYPE:</b>	NEW ASSIGNMENT
<b>NATURE OF CONVEYANCE:</b>	ASSIGNMENT

**CONVEYING PARTY DATA**

Name	Execution Date
JIN HO LEE	07/24/2015
HUI YONG KIM	07/24/2015
SE YOON JEONG	08/03/2015
SUK HEE CHO	07/24/2015
HA HYUN LEE	07/24/2015
JONG HO KIM	07/24/2015
SUNG CHANG LIM	07/24/2015
JIN SOO CHOI	07/27/2015
JIN WOONG KIM	07/27/2015
CHIE TEUK AHN	08/10/2015

**RECEIVING PARTY DATA**

<b>Name:</b>	ELECTRONICS AND TELECOMMUNICATIONS RESEARCH INSTITUTE
<b>Street Address:</b>	218, GAJEONG-RO, YUSEONG-GU
<b>City:</b>	DAEJEON
<b>State/Country:</b>	KOREA, REPUBLIC OF

**PROPERTY NUMBERS Total: 1**

Property Type	Number
<b>Application Number:</b>	14825825

**CORRESPONDENCE DATA**

**Fax Number:** (630)908-7653  
*Correspondence will be sent to the e-mail address first; if that is unsuccessful, it will be sent using a fax number, if provided; if that is unsuccessful, it will be sent via US Mail.*

**Phone:** 6309087652  
**Email:** uspto.actions@wpapat.com  
**Correspondent Name:** WILLIAM PARK & ASSOCIATES LTD.  
**Address Line 1:** 930 N. YORK ROAD, SUITE 201  
**Address Line 4:** HINSDALE, ILLINOIS 60521



<b>ATTORNEY DOCKET NUMBER:</b>	PA0929-2C
<b>NAME OF SUBMITTER:</b>	WOOCHOON W. PARK

<b>SIGNATURE:</b>	/Woochoon W. Park/
<b>DATE SIGNED:</b>	08/13/2015
	This document serves as an Oath/Declaration (37 CFR 1.63).
<b>Total Attachments: 6</b> source=PA0929-2C_Declaration_Assignment#page1.tif source=PA0929-2C_Declaration_Assignment#page2.tif source=PA0929-2C_Declaration_Assignment#page3.tif source=PA0929-2C_Declaration_Assignment#page4.tif source=PA0929-2C_Declaration_Assignment#page5.tif source=PA0929-2C_Declaration_Assignment#page6.tif	

**DECLARATION (37 CFR 1.63) FOR UTILITY OR DESIGN APPLICATION  
USING AN APPLICATION DATA SHEET (37 CFR 1.76) AND ASSIGNMENT**

<p><b>Title of Invention</b></p>	<p>METHOD AND APPARATUS FOR PERFORMING INTRA-PREDICTION USING ADAPTIVE FILTER</p>
<p><b>Declaration</b></p>	<p>As the below named inventor(s), I hereby declare that:                  The declaration is directed to:  <input checked="" type="checkbox"/> The attached application, or  <input type="checkbox"/> United States application or PCT international application number <u>PCT/KR#####</u> filed on _____.                  The above-identified application was made or authorized to be made by me.                  I believe that I am the original or an original joint inventor of a claimed invention in the application.                  I hereby acknowledge that any willful false statement made in this declaration is punishable under 18 U.S.C. 1001 by fine or imprisonment of not more than five (5) years or both.</p>
<p><b>Assignment</b></p>	<p>NOW, THEREFORE, in consideration of the sum of one dollar (\$1), the receipt whereof is acknowledge, and other good and valuable consideration, I, by these presents do sell, assign and transfer unto said assignee(s)</p> <p align="center"><b>ELECTRONICS AND TELECOMMUNICATIONS RESEARCH INSTITUTE</b></p> <p>and the heirs, successors, assigns and legal representatives of the assignee(s) the full and exclusive right to the said invention in the United States and in its territorial possessions and in any and all foreign countries any and all improvements thereof, the entire rights, title and interest in and to any and all Patents which may be granted therefore in the United States. I hereby authorize and request the Director of the U.S. Patent and Trademark Office to issue said United States Patent to said assignee(s), of the entire right, title, and interest in and to the same, for his sole use and for the use of his legal representatives, to the full end of the term for which said Patent may be granted, as fully and entirely as the same would have been held by me had this assignment and sale not been made.</p> <p>I agree promptly upon request of the assignee(s), its heirs, successors, assigns and legal representatives of the assignee(s) to communicate any facts known to it respecting the patent and the invention set forth therein, and to execute and deliver without further compensation any power of attorney, Assignment application, whether original, continuation, divisional or reissue, or other papers that may be necessary.</p> <p>I hereby covenant that no assignment, sale agreement or encumbrance has been or will be made or entered into which would conflict with this assignment and sale.</p> <p>I further covenant that assignee(s) will, upon its request, be provided promptly with all pertinent facts and documents relating to said invention and said Letters Patent and legal equivalents as may be known and accessible to me and will testify as to the same in any litigation related thereto and will promptly execute and deliver to assignee(s) or its legal representatives any and all papers, instruments or affidavits required to apply for, obtain, maintain, issue and enforce said application, said invention and said Letters Patent and said equivalents thereof which may be necessary or desirable to carry out the purposes thereof.</p>

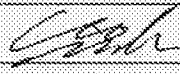
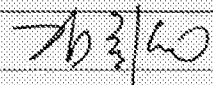
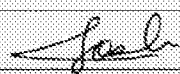
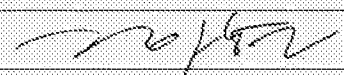
**DECLARATION (37 CFR 1.63) FOR UTILITY OR DESIGN APPLICATION  
USING AN APPLICATION DATA SHEET (37 CFR 1.76) AND ASSIGNMENT**

Legal Name Of Inventor	Inventor Name (First Middle LAST):	Jin Ho LEE
	Inventor Signature:	
	Date:	Jul. 24. 2015
Legal Name Of Joint Inventor, If Any	Inventor Name (First Middle LAST):	Hui Yong KIM
	Inventor Signature:	
	Date:	Jul. 24. 2015
Legal Name Of Joint Inventor, If Any	Inventor Name (First Middle LAST):	Se Yoon JEONG
	Inventor Signature:	
	Date:	
Legal Name Of Joint Inventor, If Any	Inventor Name (First Middle LAST):	Suk Hee CHO
	Inventor Signature:	
	Date:	Jul. 24. 2015
Legal Name Of Joint Inventor, If Any	Inventor Name (First Middle LAST):	Ha Hyun LEE
	Inventor Signature:	
	Date:	Jul. 24. 2015
Legal Name Of Joint Inventor, If Any	Inventor Name (First Middle LAST):	Jong Ho KIM
	Inventor Signature:	
	Date:	Jul. 24, 2015
Legal Name Of Joint Inventor, If Any	Inventor Name (First Middle LAST):	Sung Chang LIM
	Inventor Signature:	
	Date:	Jul. 24, 2015

**DECLARATION (37 CFR 1.63) FOR UTILITY OR DESIGN APPLICATION  
USING AN APPLICATION DATA SHEET (37 CFR 1.76) AND ASSIGNMENT**

Legal Name Of Joint Inventor, If Any	Inventor Name (First Middle LAST):	Jin Soo CHOI
	Inventor Signature:	
	Date:	July 27, 2015

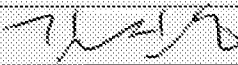
Legal Name Of Joint Inventor, If Any	Inventor Name (First Middle LAST):	Jin Woong KIM
	Inventor Signature:	
	Date:	July 27, 2015.

Legal Name Of Joint Inventor, If Any	Inventor Name (First Middle LAST):	Chie Teuk AHN
	Inventor Signature:	
	Date:	1 <sup>st</sup> , Aug 2015

**DECLARATION (37 CFR 1.63) FOR UTILITY OR DESIGN APPLICATION  
USING AN APPLICATION DATA SHEET (37 CFR 1.76) AND ASSIGNMENT**

<p><b>Title of Invention</b></p>	<p>METHOD AND APPARATUS FOR PERFORMING INTRA-PREDICTION USING ADAPTIVE FILTER</p>
<p><b>Declaration</b></p>	<p>As the below named inventor(s), I hereby declare that:          The declaration is directed to:  <input checked="" type="checkbox"/> The attached application, or  <input type="checkbox"/> United States application or PCT international application number  <u>PCT/KR#####</u> filed on _____ .          The above-identified application was made or authorized to be made by me.          I believe that I am the original or an original joint inventor of a claimed invention in the application.          I hereby acknowledge that any willful false statement made in this declaration is punishable under 18 U.S.C. 1001 by fine or imprisonment of not more than five (5) years or both.</p>
<p><b>Assignment</b></p>	<p>NOW, THEREFORE, in consideration of the sum of one dollar (\$1), the receipt whereof is acknowledge, and other good and valuable consideration, I, by these presents do sell, assign and transfer unto said assignee(s)</p> <p align="center"><b>ELECTRONICS AND TELECOMMUNICATIONS RESEARCH INSTITUTE</b></p> <p>and the heirs, successors, assigns and legal representatives of the assignee(s) the full and exclusive right to the said invention in the United States and in its territorial possessions and in any and all foreign countries any and all improvements thereof, the entire rights, title and interest in and to any and all Patents which may be granted therefore in the United States. I hereby authorize and request the Director of the U.S. Patent and Trademark Office to issue said United States Patent to said assignee(s), of the entire right, title, and interest in and to the same, for his sole use and for the use of his legal representatives, to the full end of the term for which said Patent may be granted, as fully and entirely as the same would have been held by me had this assignment and sale not been made.</p> <p>I agree promptly upon request of the assignee(s), its heirs, successors, assigns and legal representatives of the assignee(s) to communicate any facts known to it respecting the patent and the invention set forth therein, and to execute and deliver without further compensation any power of attorney, Assignment, application, whether original, continuation, divisional or reissue, or other papers that may be necessary.</p> <p>I hereby covenant that no assignment, sale agreement or encumbrance has been or will be made or entered into which would conflict with this assignment and sale.</p> <p>I further covenant that assignee(s) will, upon its request, be provided promptly with all pertinent facts and documents relating to said invention and said Letters Patent and legal equivalents as may be known and accessible to me and will testify as to the same in any litigation related thereto and will promptly execute and deliver to assignee(s) or its legal representatives any and all papers, instruments or affidavits required to apply for, obtain, maintain, issue and enforce said application, said invention and said Letters Patent and said equivalents thereof which may be necessary or desirable to carry out the purposes thereof.</p>

**DECLARATION (37 CFR 1.63) FOR UTILITY OR DESIGN APPLICATION  
USING AN APPLICATION DATA SHEET (37 CFR 1.76) AND ASSIGNMENT**

<b>Legal Name Of Inventor</b>	Inventor Name (First Middle LAST):	Jin Ho LEE
	Inventor Signature:	
	Date:	

<b>Legal Name Of Joint Inventor, if Any</b>	Inventor Name (First Middle LAST):	Hui Yong KIM
	Inventor Signature:	
	Date:	

<b>Legal Name Of Joint Inventor, if Any</b>	Inventor Name (First Middle LAST):	Se Yoon JEONG
	Inventor Signature:	<i>Se Yoon Jeong</i>
	Date:	<i>Aug - 3. 2015</i>

<b>Legal Name Of Joint Inventor, if Any</b>	Inventor Name (First Middle LAST):	Suk Hee CHO
	Inventor Signature:	
	Date:	

<b>Legal Name Of Joint Inventor, if Any</b>	Inventor Name (First Middle LAST):	Ha Hyun LEE
	Inventor Signature:	
	Date:	

<b>Legal Name Of Joint Inventor, if Any</b>	Inventor Name (First Middle LAST):	Jong Ho KIM
	Inventor Signature:	
	Date:	

<b>Legal Name Of Joint Inventor, if Any</b>	Inventor Name (First Middle LAST):	Sung Chang LIM
	Inventor Signature:	
	Date:	



<b>DECLARATION (37 CFR 1.63) FOR UTILITY OR DESIGN APPLICATION USING AN APPLICATION DATA SHEET (37 CFR 1.76) AND ASSIGNMENT</b>
---

<b>Legal Name Of Joint Inventor, If Any</b>	Inventor Name (First Middle LAST):	Jin Soo CHOI
	Inventor Signature:	
	Date:	

<b>Legal Name Of Joint Inventor, If Any</b>	Inventor Name (First Middle LAST):	Jin Woong KIM
	Inventor Signature:	
	Date:	

<b>Legal Name Of Joint Inventor, If Any</b>	Inventor Name (First Middle LAST):	Chie Teuk AHN
	Inventor Signature:	
	Date:	