



US008681867B2

(12) **United States Patent**
Teng et al.

(10) **Patent No.:** **US 8,681,867 B2**
(45) **Date of Patent:** **Mar. 25, 2014**

(54) **SELECTIVE DEBLOCK FILTERING TECHNIQUES FOR VIDEO CODING BASED ON MOTION COMPENSATION RESULTING IN A CODED BLOCK PATTERN VALUE**

FOREIGN PATENT DOCUMENTS

JP 2005020771 A 1/2005

OTHER PUBLICATIONS

(75) Inventors: **Chia-Yuan Teng**, San Diego, CA (US); **Sharath Manjunath**, San Diego, CA (US); **Yan Ye**, San Diego, CA (US)

Srinivasean S et al, "Windows Media Video 9: overview and applications." Signal Processing. Image Communication Elsevier Science Publishers, Amsterdam, NL, vol. 19, No. 9, Oct. 2004, pp. 851-875.
Xiaoyan Sun et al, "In-loop deblocking filter for block-based video coding" Signal Processing, 2002 6th International Conference on Aug. 26-30, 2002, Piscataway, NJ, USA, IEEE, vol. 1, Aug. 26, 2002, pp. 33-36.

(73) Assignee: **QUALCOMM Incorporated**, San Diego, CA (US)

Puri A et al, "Video coding using the H.264/MPEG-4 AVC compression standard" Signal Processing. Image Communication, Elsevier Science Publishers, Amsterdam, NL, vol. 19, No. 9, Oct. 2004, pp. 793-849.

(*) Notice: Subject to any disclaimer, the term of this patent is extended or adjusted under 35 U.S.C. 154(b) by 1617 days.

Srinivasan S, Signal Processing: Image Communication, NL, Elsevier Science Publishers, Oct. 2004, V19 N9, pp. 851-875.

(21) Appl. No.: **11/350,666**

(Continued)

(22) Filed: **Feb. 8, 2006**

(65) **Prior Publication Data**

US 2011/0110427 A1 May 12, 2011

Related U.S. Application Data

(60) Provisional application No. 60/728,361, filed on Oct. 18, 2005.

Primary Examiner — Leron Beck

(74) *Attorney, Agent, or Firm* — Timothy F. Loomis; Brent Boyd

(51) **Int. Cl.**
H04N 11/02 (2006.01)

(57) **ABSTRACT**

(52) **U.S. Cl.**
USPC **375/240.16**

This disclosure describes selective deblock filtering techniques that are particularly useful with coding standards that do not specify in-loop deblock filtering for standard compliance. In accordance with this disclosure, deblock filtering may be selectively performed with respect to block boundaries of a given video block being coded, a motion compensation process can be performed using a filtered version of the prediction video frame used to code the given video block, or both. This disclosure also provides selection rules that can be applied to determine what type of deblocking techniques to apply in various scenarios. The selection rules may improve the video coding and may also ensure that mismatch between video blocks at an encoder and a decoder is not introduced by the deblock filtering.

(58) **Field of Classification Search**
USPC 375/240.01-240.29
See application file for complete search history.

(56) **References Cited**

U.S. PATENT DOCUMENTS

- 5,173,773 A * 12/1992 Ueda et al. 375/240.18
- 5,892,518 A * 4/1999 Mizobata et al. 345/474
- 2005/0053145 A1 * 3/2005 Hsu et al. 375/240.16
- 2005/0175091 A1 * 8/2005 Puri et al. 375/240.03
- 2006/0251174 A1 * 11/2006 Caviedes et al. 375/240.24

31 Claims, 5 Drawing Sheets

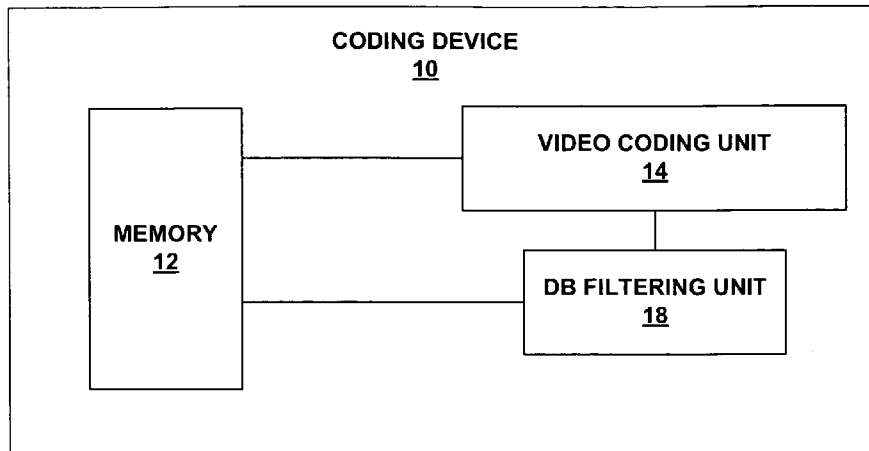

(56)

References Cited

OTHER PUBLICATIONS

Translation of Office Action in Japan application 2008-536779 corresponding to U.S. App. No. 11/350,666, citing Srinivasan_S_Signal_Processing_pp_851_875_year_2004 and JP2005020771 dated Feb. 22, 2011.

“Windows Media Video 9: overview and applications”.

Xiaoyan Sun et al: “In-loop deblocking filter for block-based video coding” Signal Processing, 2002 6th International Conference on Aug. 26-30, 2002, Piscataway, NJ, USA, IEEE, vol. 1, Aug. 26, 2002, pp. 33-36, XP010627917.

International Search Report and Written Opinion—PCT/US2006/040761—ISA/EPO-Mar. 23, 2007.

* cited by examiner

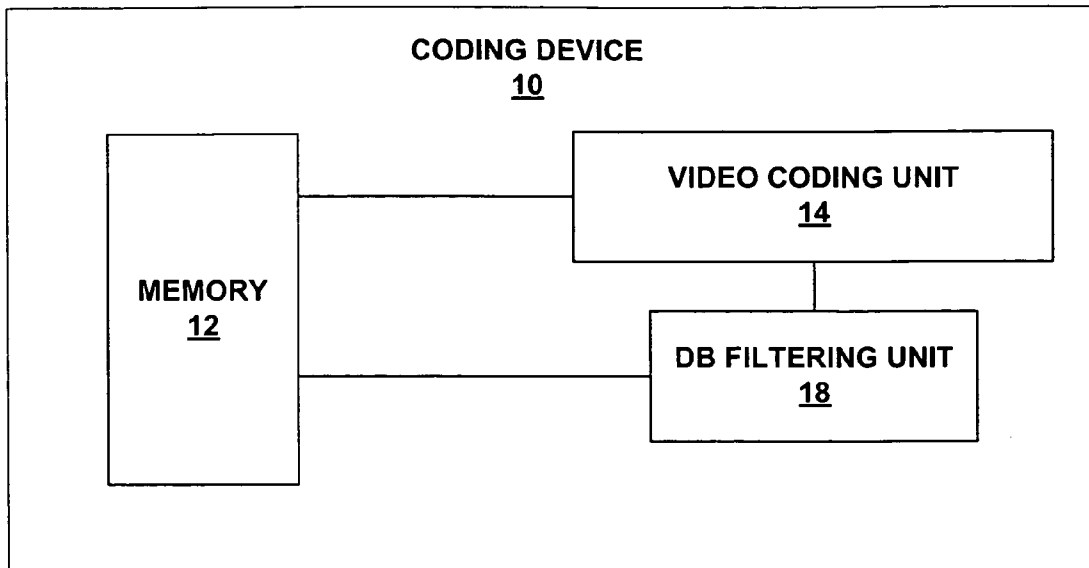

FIG. 1

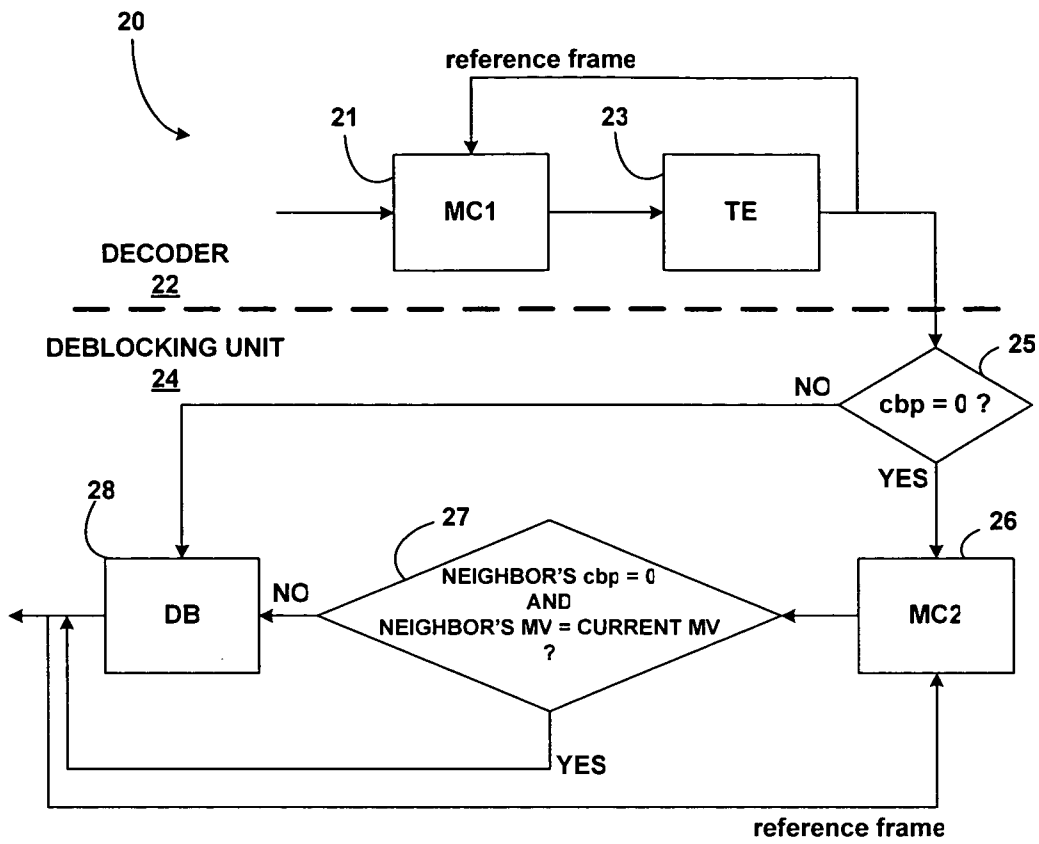

FIG. 2

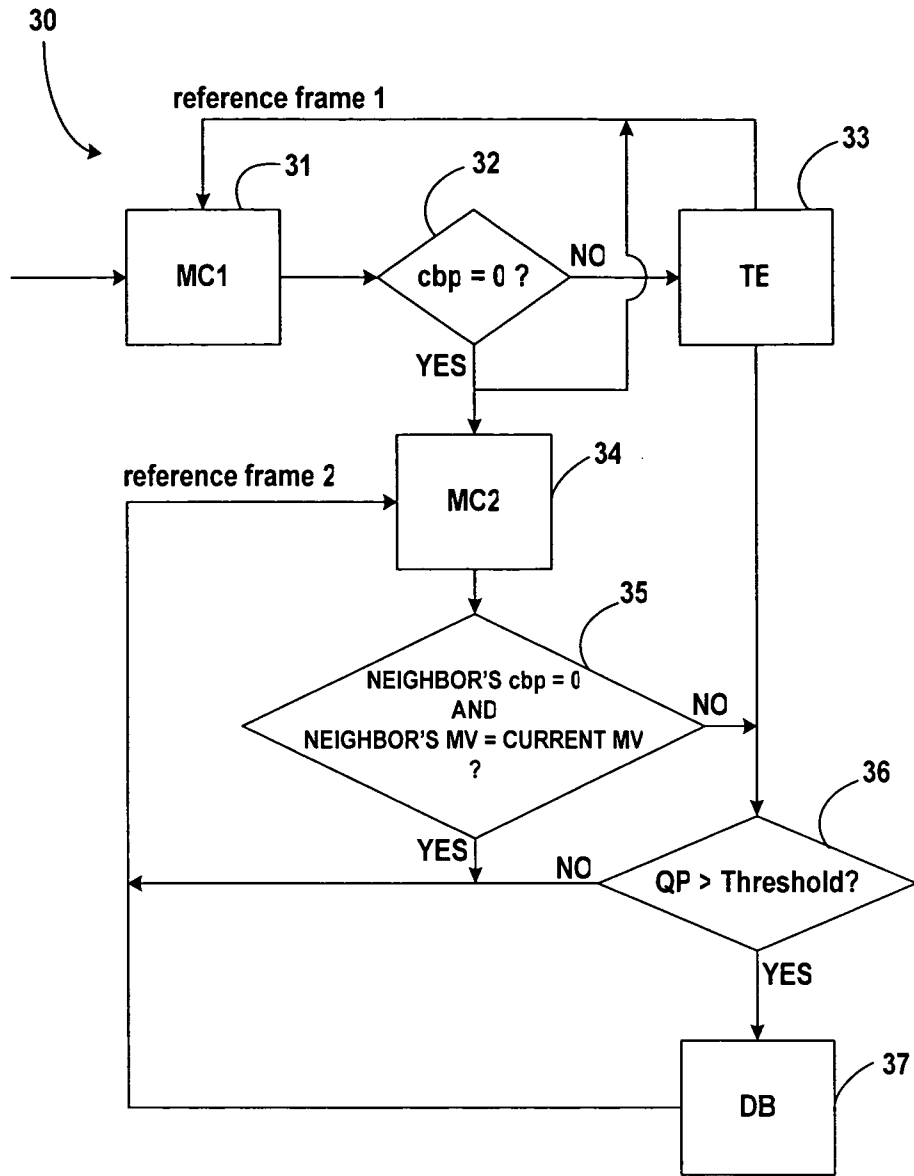

FIG. 3

Explore Litigation Insights

Docket Alarm provides insights to develop a more informed litigation strategy and the peace of mind of knowing you're on top of things.

Real-Time Litigation Alerts



Keep your litigation team up-to-date with **real-time alerts** and advanced team management tools built for the enterprise, all while greatly reducing PACER spend.

Our comprehensive service means we can handle Federal, State, and Administrative courts across the country.

Advanced Docket Research



With over 230 million records, Docket Alarm's cloud-native docket research platform finds what other services can't. Coverage includes Federal, State, plus PTAB, TTAB, ITC and NLRB decisions, all in one place.

Identify arguments that have been successful in the past with full text, pinpoint searching. Link to case law cited within any court document via Fastcase.

Analytics At Your Fingertips



Learn what happened the last time a particular judge, opposing counsel or company faced cases similar to yours.

Advanced out-of-the-box PTAB and TTAB analytics are always at your fingertips.

API

Docket Alarm offers a powerful API (application programming interface) to developers that want to integrate case filings into their apps.

LAW FIRMS

Build custom dashboards for your attorneys and clients with live data direct from the court.

Automate many repetitive legal tasks like conflict checks, document management, and marketing.

FINANCIAL INSTITUTIONS

Litigation and bankruptcy checks for companies and debtors.

E-DISCOVERY AND LEGAL VENDORS

Sync your system to PACER to automate legal marketing.