

Food Processing and Technology 1984: A Summary of Research

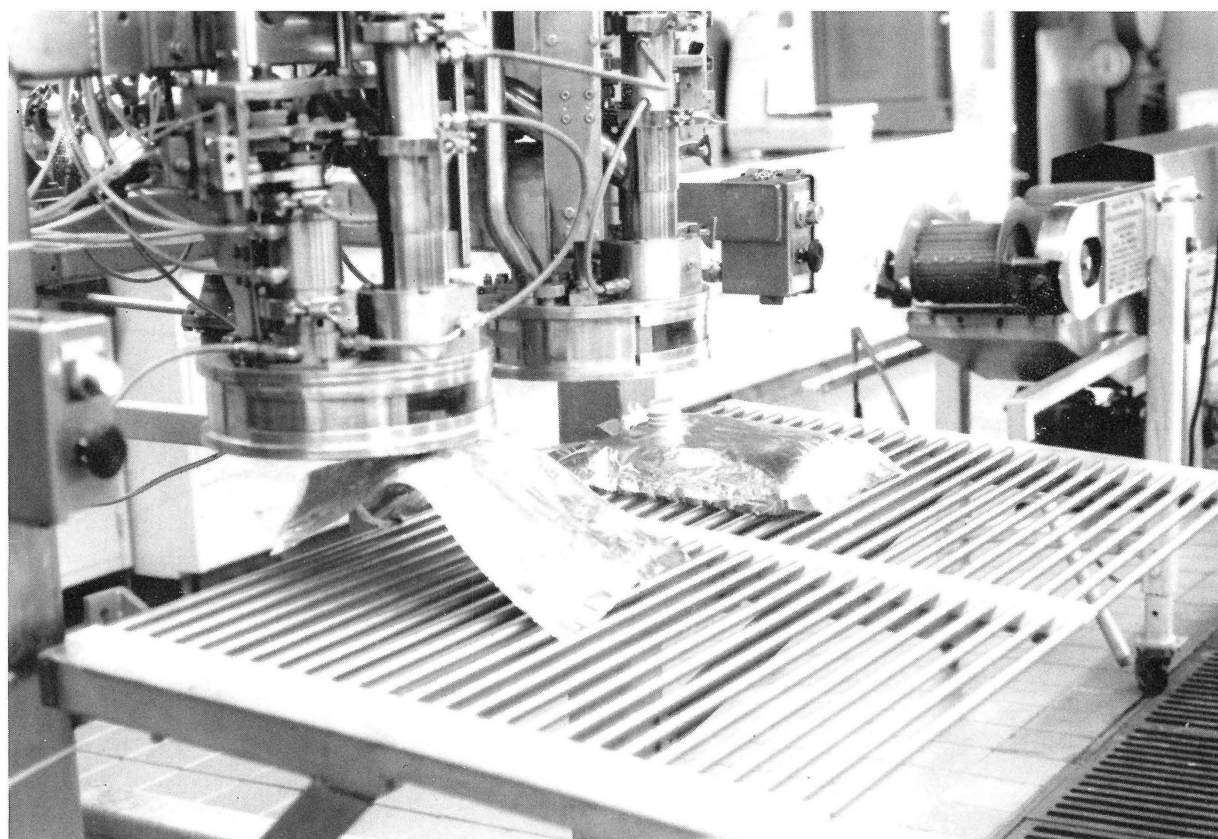

The Ohio State University
Ohio Agricultural Research and Development Center
Wooster, Ohio

CONTENTS

Textural Properties of Ohio Curd, by H. M. Wu and A. C. Peng	3
Quality Evaluation of New Potato Cultivars—Before and After Storage—for Chip Manufacture, by Wilbur A. Gould.....	7
Color Evaluation of Potato Chips, by Wilbur A. Gould and Kent Rogers . . .	11
Evaluation of Tomato Cultivars for Processing, by W. A. Gould, S. Z. Berry, W. D. Bash, and J. Dalmasso.....	14
Aseptic Processing of Diced Tomatoes, by Winston D. Bash and Wilbur A. Gould	26
The Addition of Sugar to Tomato Paste, by W. D. Bash, J. P. Dalmasso, and W. A. Gould.....	28

ON THE COVER: Flexible film aseptic packaging machine.

Mention of a trademark, proprietary product, or vendor does not constitute a guarantee of the product by The Ohio State University, Ohio Agricultural Research and Development Center, or Ohio Cooperative Extension Service, and does not imply its approval to the exclusion of other products or vendors which also may be suitable.

All publications of the Ohio Agricultural Research and Development Center are available to all on a nondiscriminatory basis without regard to race, color, national origin, sex, or religious affiliation.

Textural Properties of Ohio Curd

H. M. WU and A. C. PENG¹

INTRODUCTION

Ohio curd was developed in our laboratory by coagulating cheese whey and soymilk with glucono-delta-lactone (10). The product was a white, soft, gelatinous mass with an acceptable aroma and texture, high yield and protein content. The addition of cheese whey protein to soymilk enriched the essential amino acid content of soybean protein to upgrade its quality. This research was undertaken to investigate the textural parameters of this product.

MATERIALS AND METHODS

Materials

Soybeans of the Vickery cultivar were obtained from the Manchester Farm, Auglaize, Ohio. Sodium Protolac, a cheese whey protein concentrate (WPC), was provided by the Industrial Food Products, Borden, Inc., Columbus, Ohio; and Glucono-delta-lactone (GDL) was purchased from Sigma Chemical Co., St. Louis, Mo.

Ohio Curd Preparation

After being washed and soaked overnight under refrigeration, the soybeans were blended with fresh tap water (pH 7.0) at water:bean ratios of 6:1, 8:1, and 10:1 (v/w) for 5 minutes in a Waring Blender. The slurry was filtered; the filtrate was boiled for 15 minutes and then cooled to 20° C. Sodium Protolac at 3%, 4.5%, 5.25%, and 6% (w/v) levels was dispersed into the cooled soymilk; the mixture deaerated for 1-1.5 hours, followed by mixing with 0.6% powdered GDL (w/v). The mixture was heated in a water bath at 85° C for 25 minutes, cooled under a running cold tap water for 25 minutes to enhance the hardening of the gel, and then refrigerated.

Textural Properties

An Instron Universal Testing Machine, Table Model TMM, CTM cell, was used to determine textural properties of the curd. Samples were tested in beakers, 6.80 cm inside diameter, filled to a depth of 3.2 cm. The flat plate plunger was 3.90 cm in diameter.

Figure 1 illustrates the position of plunger and sample upon initiation of the downstroke of the plunger. During the descent of the plunger, the crosshead speed was set at 1.0 cm/minute, chart speed was 20.0 cm/minute, and full scale deflection was 2.0 kg. Plunger penetration length was stopped at 1.0 cm. The relaxation curve was obtained by continuing to record the decay of the force, after the plunger was stopped, until a certain period of time had elapsed. Samples were tested at 22.2° C -23.3° C.

Three parameters: stiffness, bioyield point, and firmness were determined in the descending test, and two

additional parameters, relaxation and plasticity, were obtained in the relaxation test. These were defined as follows:

Stiffness: the slope of the straight line in the force-distance curve during downstroke, having dimensions of kg/cm.

Bioyield point: the force (kg) at the peak or plateau in the force-distance curve during downstroke.

Firmness: the maximum force (kg) in the force-distance curve during downstroke.

Relaxation: the slope of the first exponential line obtained from the relaxation curve by using the successive residual method (5).

Plasticity: estimate based on the relaxation curve at the time of 4.4 min.

Data were statistically analyzed at the 95% confidence interval.

RESULTS

Textural Properties of Ohio Curd

The data in Figure 2 show the typical force-distance curve of Ohio curds obtained from the Instron Universal Testing Machine during the descent of the plunger. The curve began with a straight line until a break point was reached. The force was still increasing with changes in the slopes and showed fluctuations as indicated by several peaks and dikes until the downstroke was ended.

The stress-relaxation curve was expressed by the decay of force against time (Fig. 3). At the beginning the

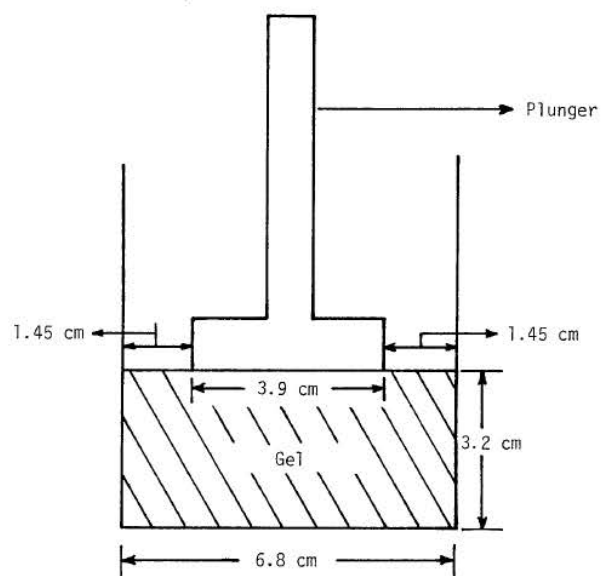

FIG. 1.—Diagram of the Instron test of the soy-WPC curd.

¹Graduate Student and Professor, Dept. of Horticulture.

force dropped sharply, then leveled off. Three parameters, stiffness, firmness, and bioyield point, were obtained from the force-distance curve (Fig. 2). Relaxation and plasticity were the two parameters obtained from the relaxation curve (Fig. 3).

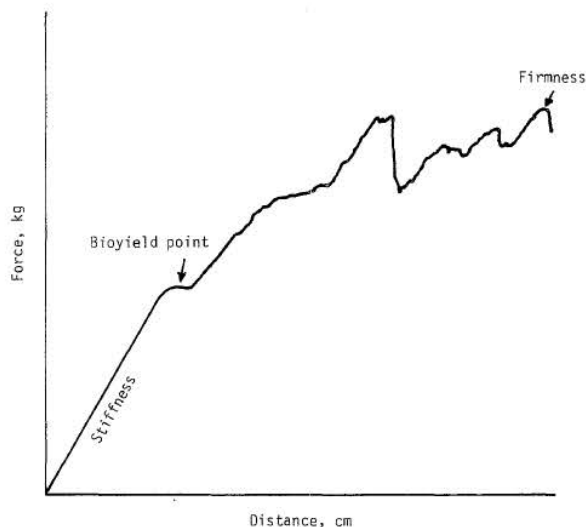

FIG. 2.—The typical force-distance curve of the downstroke of the Ohio curd obtained from the Instron machine.

Effect of WPC Concentration on Textural Properties of Ohio Curd

The mean values of textural parameters of Ohio curds are given in Table 1. For stiffness, curds containing 3%, 4.5%, 5.25%, and 6% WPC had mean values of 3.31, 3.39, 3.60, and 3.99 kg/cm, respectively. For firmness, the curd had mean values of 1.21, 1.31, 1.37, and 1.51 kg, while bioyield points were 0.74, 0.78, 0.81, and 0.87 kg, respectively. The mean values for four replicates of relaxation at 3%, 4.5%, 5.25%, and 6% WPC were 0.24, 0.24, 0.23, and 0.21 min⁻¹, respectively. Curds made with 3% WPC had plasticity 0.84, while those made with 4.5%, 5.25%, and 6% WPC had identical mean values of 0.77.

Effect of Soymilk Concentration on Textural Properties of Ohio Curds

Mean values of five textural parameters of Ohio curds prepared at different soymilk concentration, *i.e.*, H₂O:bean ratio (v/w), are tabulated in Table 2. For stiffness, H₂O:bean ratio at 10:1 was 2.91 kg/cm, at 8:1 was 3.74 kg/cm, and at 6:1 was 4.29 kg/cm. Firmness was 1.46 kg at 10:1, 1.85 kg at 8:1, and 1.81 kg at 6:1. For bioyield point, the mean value at 10:1 was 0.75 kg, at 8:1 was 0.94 kg, and at 6:1 was 1.0 kg. Relaxations at H₂O:bean ratio at 10:1, 8:1, and 6:1 were 0.25, 0.23, and 0.17 min⁻¹, respectively. Plasticities were 0.84, 0.82, and 0.75 for H₂O:bean ratio at 10:1, 8:1, and 6:1, respectively.

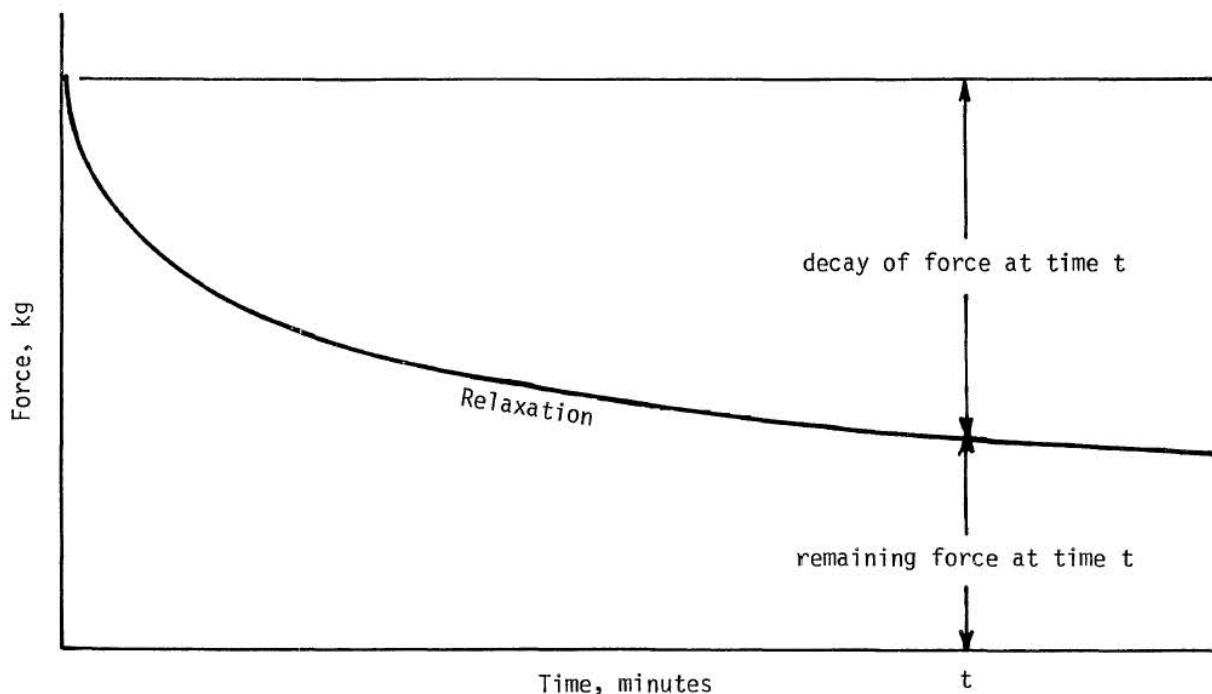

FIG. 3.—The stress relaxation curve of the Ohio curd obtained from the Instron machine.

TABLE 1.—Textural Parameters of Ohio Curd as a Function of WPC Concentration.*

Textural Parameter	N	Concentration of WPC (w/v)			
		3%	4.5%	5.25%	6%
Stiffness (kg/cm)	7	3.31	3.39	3.60	3.99
Firmness (kg)	7	1.21	1.31	1.37	1.51
Bioyield point (kg)	7	0.74	0.78	0.81	0.87
Relaxation (min ⁻³)	4	0.24	0.24	0.23	0.21
Plasticity	6	0.84	0.77	0.77	0.77

*Mean value of textural parameters of Ohio curds. Soymilk: H₂O:bean = 6:1 (v/w). WPC = 3%, 4.5%, 5.25%, and 6% (w/v). Sodium Protolac was used. N = No. of replicates of curd preparation.

Partial Correlation Among Textural Parameters

As illustrated in Table 3, stiffness was significantly correlated with firmness, bioyield point, and plasticity (at 95% C.I.), having correlation coefficients of 0.75, 0.67, and -0.74, respectively. Firmness showed a significant correlation (at 95% C.I.) with bioyield point and had a correlation coefficient of 0.85. There was a significant correlation between bioyield point and plasticity with a coefficient of -0.63 (at 95% C.I.).

DISCUSSION

Textural Properties of Ohio Curd

The force-distance curve of the downstroke presented a typical pattern as the curve always began with a linear portion until a break was reached, followed by a change in slopes with continuing increasing force, and showing fluctuation in the force by many dips and peaks until the downstroke was ended (Fig. 2). The interpretation of the curve is that as the flat plate plunger contacted and descended into the curd, force began to increasingly build up until it was sufficient to rupture the cells on the top surface. The steepness of the slope, which is defined as stiffness, is a measure of the ease at which the gel is deformed (4).

The force required to rupture the surface (defined as bioyield point) is a measure of gel strength (4) and is most likely tensile strength as the gel surface bends over the edge of the flat plate (9). As the flat plate plunger penetrated the curd, force still increased with a change in slopes and showed fluctuation, presumably due to the flow (the gel is 84-87% water) and the nonhomogeneity of the curd (2, 3, 4, 9). Firmness, the height of the maximum peak (whose reading was affected by the combination of flow properties of the curd, shearing, and compression effects [1]) was thought to be related to

TABLE 2.—Textural Parameters as a Function of Soymilk Concentration.*

Parameter	N	Soymilk Concentration (H ₂ O:bean v/w)		
		10:1	8:1	6:1
Stiffness (kg/cm)	3	2.91	3.74	4.29
Firmness (kg)	3	1.46	1.85	1.81
Bioyield point (kg)	3	0.75	0.94	1.00
Relaxation (min ⁻³)	3	0.25	0.23	0.17
Plasticity	3	0.84	0.82	0.75

*Mean values of textural parameters of Ohio curd. Soymilk: H₂O:bean = 10:1, 8:1, and 6:1 (v/w). WPC (Sodium Protolac) = 6% (w/v). N = No. of replicates of curd preparation.

the cohesiveness — the strength of the internal bonds making up the body of the product (8).

For the relaxation curve, Peleg and Calzada (6) reported that the stress-relaxation curve was dependent on the deformation history of the material and the absolute and relative magnitudes of the Maxwell model's elements. After a long relaxation time ($t > \infty$), the generalized Maxwell body may approach zero force or a constant force depending on the absence or presence of an elastic element parallel to the rest of the Maxwell element.

Shama and Sherman (7) stated that the food materials which are viscoelastic in nature show relaxation patterns somewhere between the ideal elastic solids which do not exhibit stress-relaxation and pure fluids which relax instantaneously. Therefore, the relaxation curve of the Ohio curd showed a sharper drop in the beginning and then leveled off as time approached infinite. The extent of this level-off depended on the internal structure of the gel when the relaxation time was standardized at a certain period. Furthermore, the indicators of the gel structure, the stiffness, bioyield point, and

TABLE 3.—Partial Correlation Coefficients Among Textural Parameters of Ohio Curds.

Textural Parameter	Firmness		Bioyield Point		Plasticity	
	Coefficient	Prob > R	Coefficient	Prob > R	Coefficient	Prob > R
Stiffness	0.752	1.22 x 10 ⁻²	0.665	3.58 x 10 ⁻²	-0.738	1.48 x 10 ⁻²
Firmness	—	—	0.851	1.80 x 10 ⁻³	-0.632	5.01 x 10 ⁻²
Bioyield Point	0.851	1.80 x 10 ⁻³	—	—	-0.633	4.96 x 10 ⁻²

$\alpha = 0.05$

Explore Litigation Insights

Docket Alarm provides insights to develop a more informed litigation strategy and the peace of mind of knowing you're on top of things.

Real-Time Litigation Alerts



Keep your litigation team up-to-date with **real-time alerts** and advanced team management tools built for the enterprise, all while greatly reducing PACER spend.

Our comprehensive service means we can handle Federal, State, and Administrative courts across the country.

Advanced Docket Research



With over 230 million records, Docket Alarm's cloud-native docket research platform finds what other services can't. Coverage includes Federal, State, plus PTAB, TTAB, ITC and NLRB decisions, all in one place.

Identify arguments that have been successful in the past with full text, pinpoint searching. Link to case law cited within any court document via Fastcase.

Analytics At Your Fingertips



Learn what happened the last time a particular judge, opposing counsel or company faced cases similar to yours.

Advanced out-of-the-box PTAB and TTAB analytics are always at your fingertips.

API

Docket Alarm offers a powerful API (application programming interface) to developers that want to integrate case filings into their apps.

LAW FIRMS

Build custom dashboards for your attorneys and clients with live data direct from the court.

Automate many repetitive legal tasks like conflict checks, document management, and marketing.

FINANCIAL INSTITUTIONS

Litigation and bankruptcy checks for companies and debtors.

E-DISCOVERY AND LEGAL VENDORS

Sync your system to PACER to automate legal marketing.