

FIG. 1

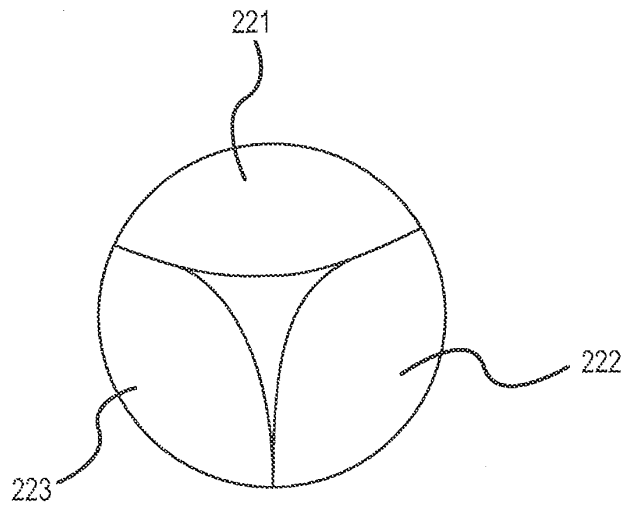


FIG.2

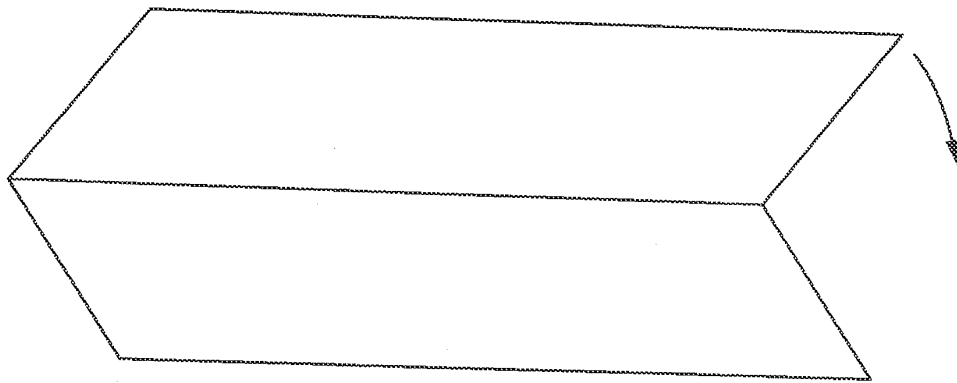


FIG.3A

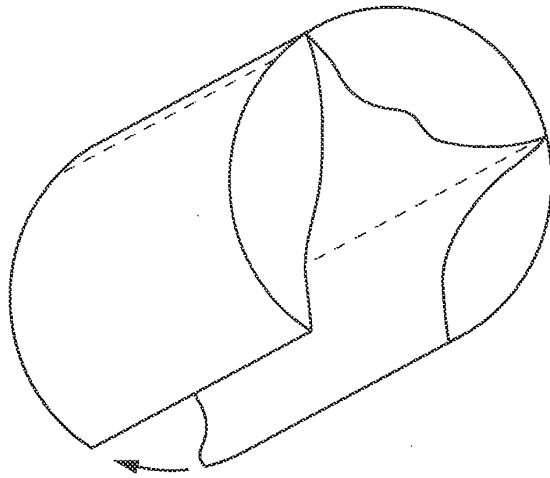


FIG.3B

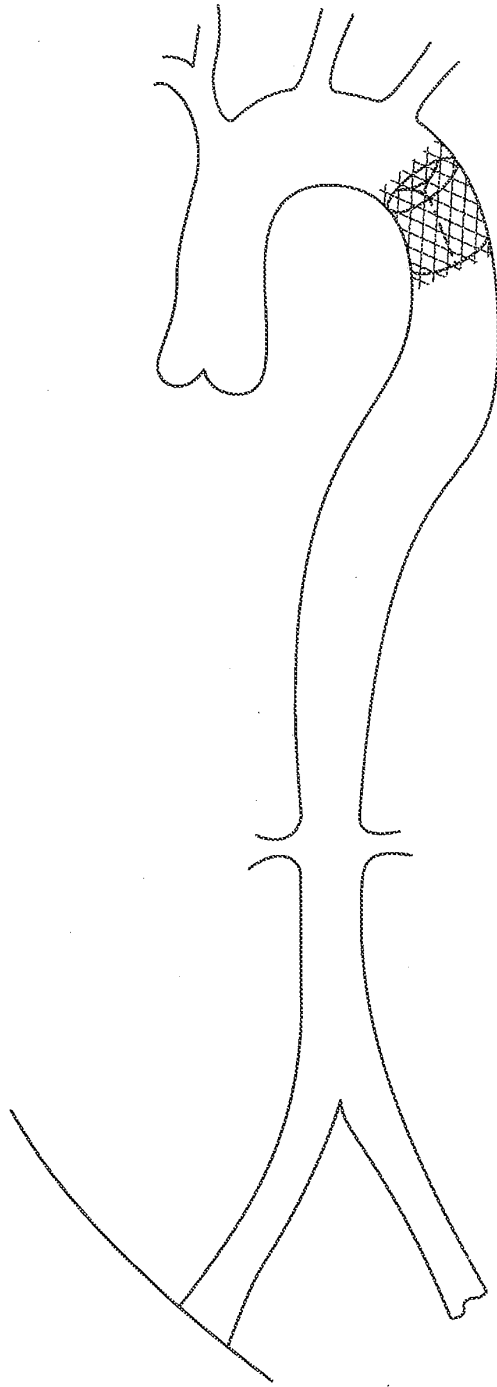


FIG.4

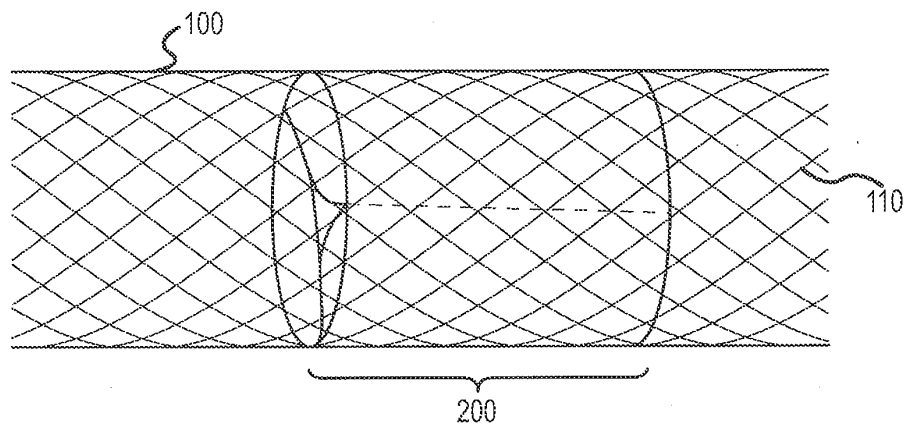


FIG.5

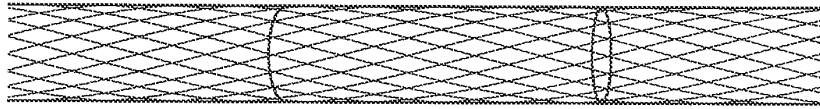


FIG.6

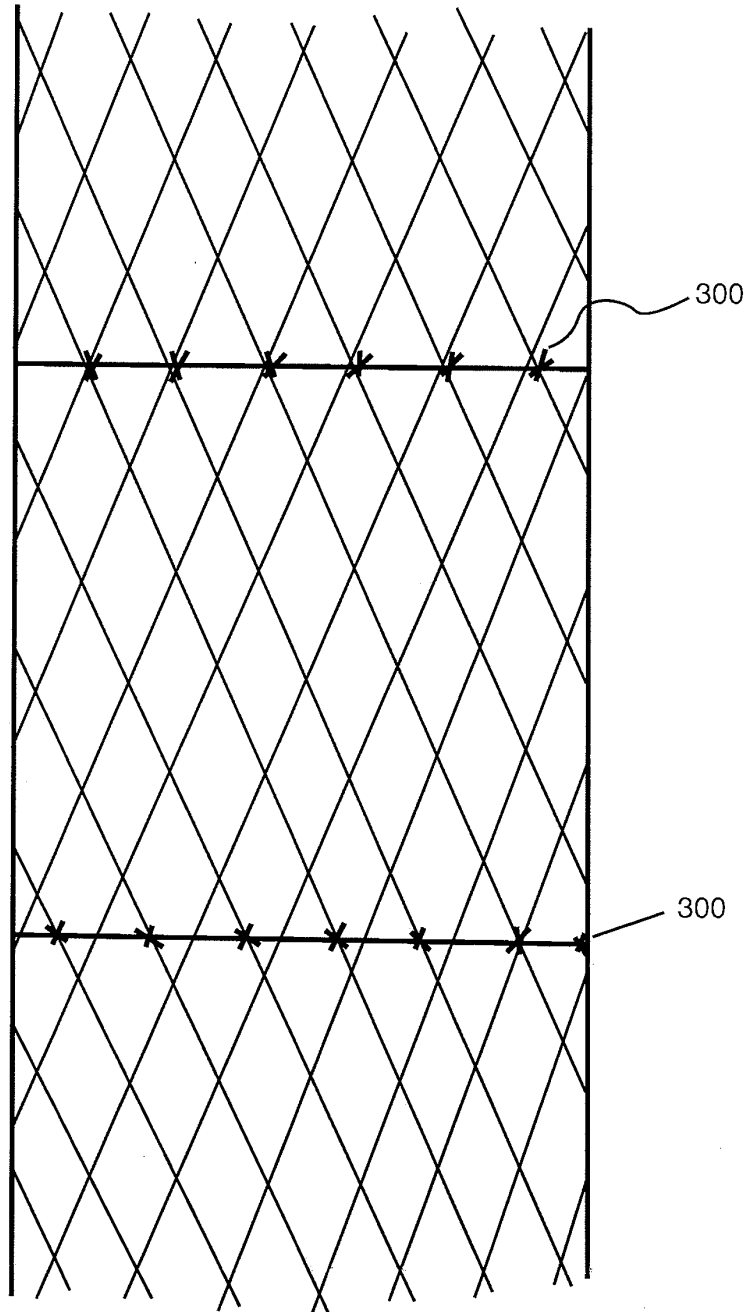


FIG. 7



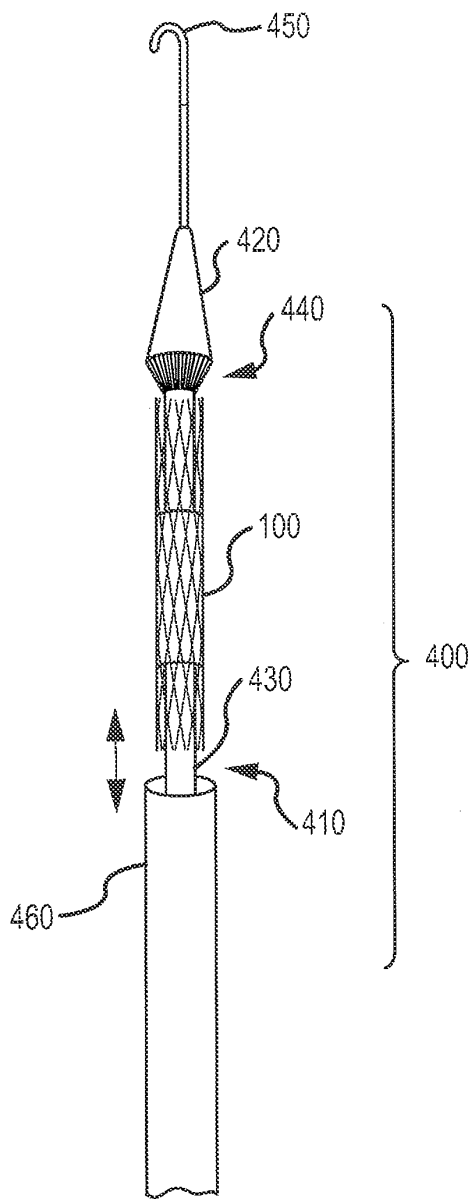


FIG.8

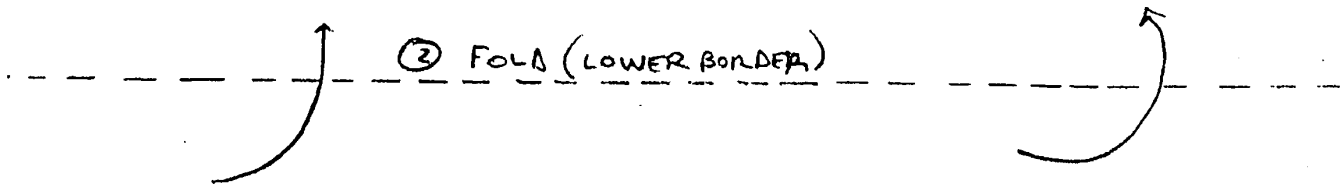
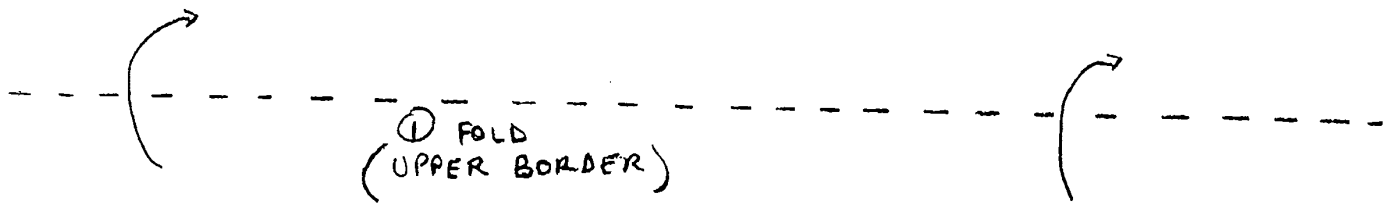


Fig. 9A

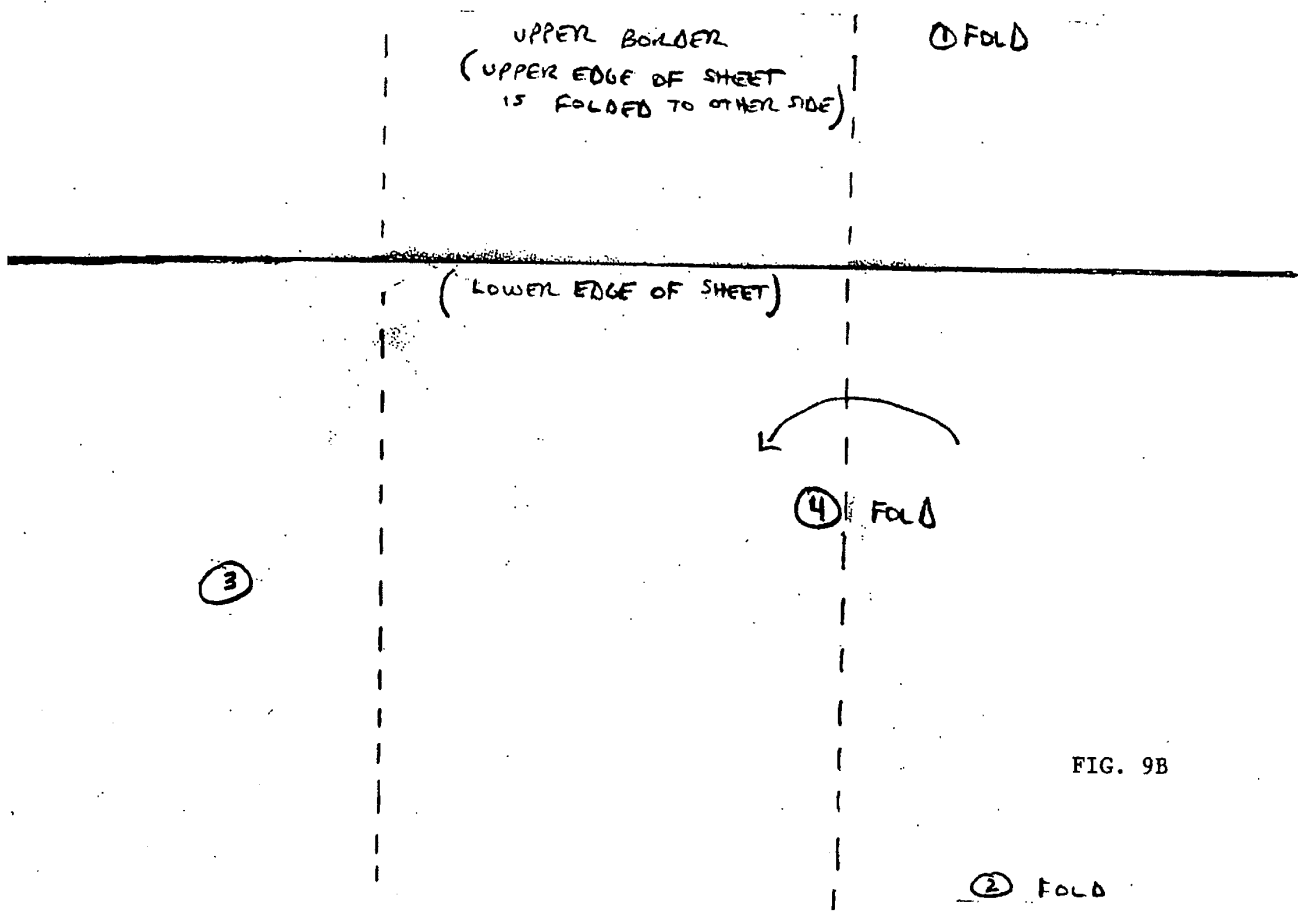
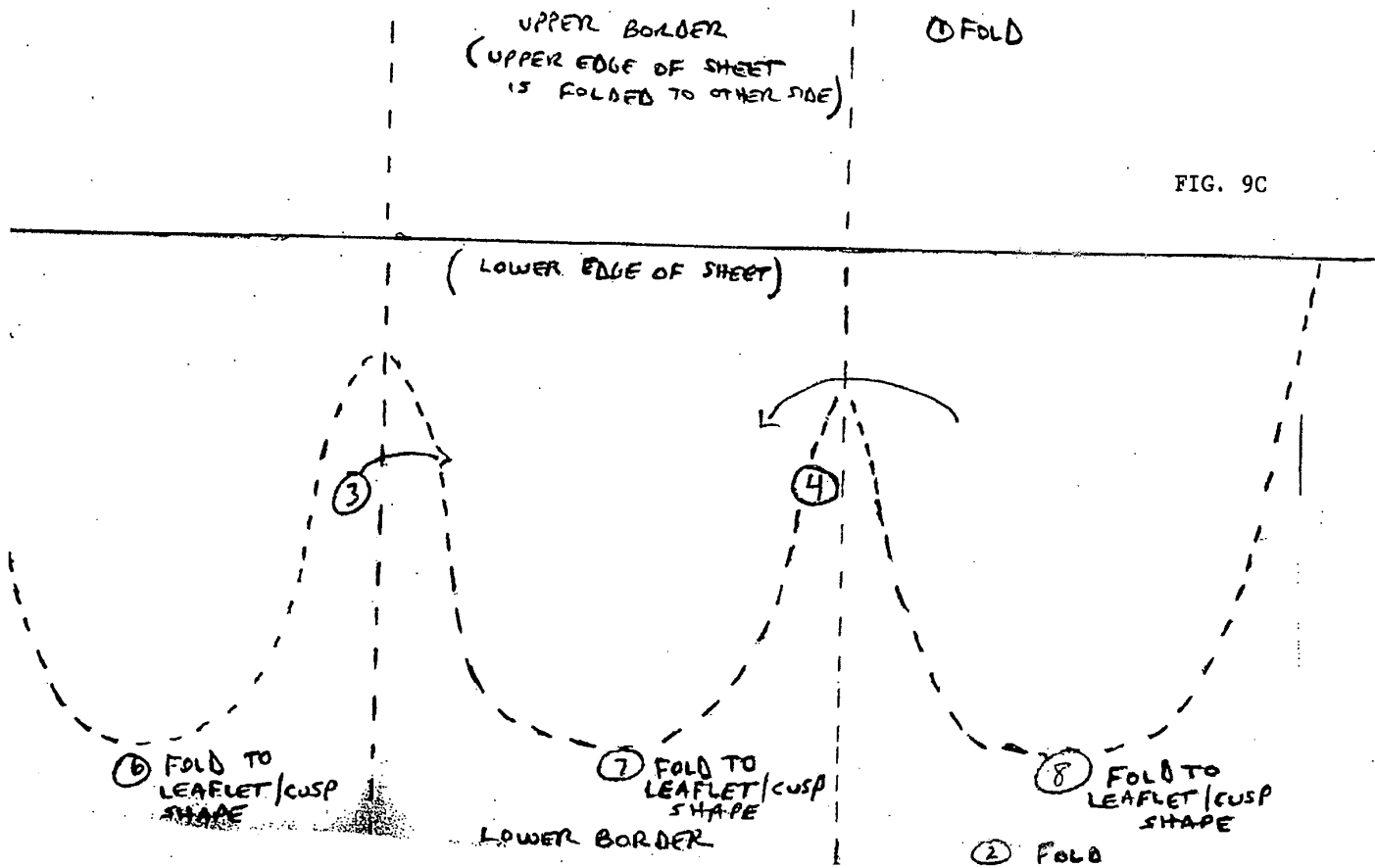


FIG. 9B



Under the Paperwork Reduction Act of 1995, no persons are required to respond to a collection of information unless it contains a valid OMB control number.

<b>Application Data Sheet 37 CFR 1.76</b>		Attorney Docket Number	109978.10101
		Application Number	
Title of Invention	PERCUTANEOUSLY IMPLANTABLE REPLACEMENT HEART VALVE DEVICE AND METHOD OF MAKING SAME		
<p>The application data sheet is part of the provisional or nonprovisional application for which it is being submitted. The following form contains the bibliographic data arranged in a format specified by the United States Patent and Trademark Office as outlined in 37 CFR 1.76. This document may be completed electronically and submitted to the Office in electronic format using the Electronic Filing System (EFS) or the document may be printed and included in a paper filed application.</p>			

## Secrecy Order 37 CFR 5.2

<input type="checkbox"/> Portions or all of the application associated with this Application Data Sheet may fall under a Secrecy Order pursuant to 37 CFR 5.2 (Paper filers only. Applications that fall under Secrecy Order may not be filed electronically.)
--

## Inventor Information:

Inventor 1 <span style="float: right;">Remove</span>				
Legal Name				
Prefix	Given Name	Middle Name	Family Name	Suffix
	..		..	
Residence Information (Select One) <input checked="" type="radio"/> US Residency <input type="radio"/> Non US Residency <input type="radio"/> Active US Military Service				
City	State/Province	Country of Residence <sup>i</sup>		
Mailing Address of Inventor:				
Address 1				
Address 2				
City	State/Province			
Postal Code	Country <sup>1</sup>			
All Inventors Must Be Listed - Additional Inventor Information blocks may be generated within this form by selecting the Add button. <span style="float: right;">Add</span>				

## Correspondence Information:

Enter either Customer Number or complete the Correspondence Information section below. For further information see 37 CFR 1.33(a).	
<input type="checkbox"/> An Address is being provided for the correspondence information of this application.	
Customer Number	29880
Email Address	<span style="float: right;">Add Email Remove Email</span>

## Application Information:

Title of the Invention	PERCUTANEOUSLY IMPLANTABLE REPLACEMENT HEART VALVE DEVICE AND METHOD OF MAKING SAME		
Attorney Docket Number	109978.10101	Small Entity Status Claimed	<input checked="" type="checkbox"/>
Application Type	Nonprovisional		
Subject Matter	Utility		
Suggested Class (if any)		Sub Class (if any)	
Suggested Technology Center (if any)			
Total Number of Drawing Sheets (if any)	12	Suggested Figure for Publication (if any)	

<b>Application Data Sheet 37 CFR 1.76</b>		Attorney Docket Number	109978.10101
		Application Number	
Title of Invention	PERCUTANEOUSLY IMPLANTABLE REPLACEMENT HEART VALVE DEVICE AND METHOD OF MAKING SAME		

**Publication Information:**

Request Early Publication (Fee required at time of Request 37 CFR 1.219)

**Request Not to Publish.** I hereby request that the attached application not be published under 35 U.S.C. 122(b) and certify that the invention disclosed in the attached application has not and will not be the subject of an application filed in another country, or under a multilateral international agreement, that requires publication at eighteen months after filing.

**Representative Information:**

Representative information should be provided for all practitioners having a power of attorney in the application. Providing this information in the Application Data Sheet does not constitute a power of attorney in the application (see 37 CFR 1.32). Either enter Customer Number or complete the Representative Name section below. If both sections are completed the customer number will be used for the Representative Information during processing.

Please Select One:	<input checked="" type="radio"/> Customer Number	<input type="radio"/> US Patent Practitioner	<input type="radio"/> Limited Recognition (37 CFR 11.9)
Customer Number	29880		

**Domestic Benefit/National Stage Information:**

This section allows for the applicant to either claim benefit under 35 U.S.C. 119(e), 120, 121, or 365(c) or indicate National Stage entry from a PCT application. Providing this information in the application data sheet constitutes the specific reference required by 35 U.S.C. 119(e) or 120, and 37 CFR 1.78.

Prior Application Status	Pending	<input type="button" value="Remove"/>	
Application Number	Continuity Type	Prior Application Number	Filing Date (YYYY-MM-DD)
	Continuation of	10887688	2004-07-10
Prior Application Status	Abandoned	<input type="button" value="Remove"/>	
Application Number	Continuity Type	Prior Application Number	Filing Date (YYYY-MM-DD)
10887688	Continuation in part of	10037266	2002-01-04
Additional Domestic Benefit/National Stage Data may be generated within this form by selecting the Add button.			<input type="button" value="Add"/>

**Foreign Priority Information:**

This section allows for the applicant to claim benefit of foreign priority and to identify any prior foreign application for which priority is not claimed. Providing this information in the application data sheet constitutes the claim for priority as required by 35 U.S.C. 119(b) and 37 CFR 1.55(a).

			<input type="button" value="Remove"/>
Application Number	Country i	Filing Date (YYYY-MM-DD)	Priority Claimed
			<input type="radio"/> Yes <input checked="" type="radio"/> No
Additional Foreign Priority Data may be generated within this form by selecting the Add button.			<input type="button" value="Add"/>

<b>Application Data Sheet 37 CFR 1.76</b>		Attorney Docket Number	109978.10101
		Application Number	
Title of Invention	PERCUTANEOUSLY IMPLANTABLE REPLACEMENT HEART VALVE DEVICE AND METHOD OF MAKING SAME		

**Authorization to Permit Access:**

<input checked="" type="checkbox"/> Authorization to Permit Access to the Instant Application by the Participating Offices
<p>If checked, the undersigned hereby grants the USPTO authority to provide the European Patent Office (EPO), the Japan Patent Office (JPO), the Korean Intellectual Property Office (KIPO), the World Intellectual Property Office (WIPO), and any other intellectual property offices in which a foreign application claiming priority to the instant patent application is filed access to the instant patent application. See 37 CFR 1.14(c) and (h). This box should not be checked if the applicant does not wish the EPO, JPO, KIPO, WIPO, or other intellectual property office in which a foreign application claiming priority to the instant patent application is filed to have access to the instant patent application.</p> <p>In accordance with 37 CFR 1.14(h)(3), access will be provided to a copy of the instant patent application with respect to: 1) the instant patent application-as-filed; 2) any foreign application to which the instant patent application claims priority under 35 U.S.C. 119(a)-(d) if a copy of the foreign application that satisfies the certified copy requirement of 37 CFR 1.55 has been filed in the instant patent application; and 3) any U.S. application-as-filed from which benefit is sought in the instant patent application.</p> <p>In accordance with 37 CFR 1.14(c), access may be provided to information concerning the date of filing this Authorization.</p>

**Applicant Information:**

Providing assignment information in this section does not substitute for compliance with any requirement of part 3 of Title 37 of CFR to have an assignment recorded by the Office.	
<b>Applicant 1</b>	
<p>If the applicant is the inventor (or the remaining joint inventor or inventors under 37 CFR 1.45), this section should not be completed. The information to be provided in this section is the name and address of the legal representative who is the applicant under 37 CFR 1.43; or the name and address of the assignee, person to whom the inventor is under an obligation to assign the invention, or person who otherwise shows sufficient proprietary interest in the matter who is the applicant under 37 CFR 1.46. If the applicant is an applicant under 37 CFR 1.46 (assignee, person to whom the inventor is obligated to assign, or person who otherwise shows sufficient proprietary interest) together with one or more joint inventors, then the joint inventor or inventors who are also the applicant should be identified in this section.</p>	
<input type="button" value="Remove"/>	
<input checked="" type="radio"/> Assignee	<input type="radio"/> Legal Representative under 35 U.S.C. 117
<input type="radio"/> Person to whom the inventor is obligated to assign.	<input type="radio"/> Person who shows sufficient proprietary interest
If applicant is the legal representative, indicate the authority to file the patent application, the inventor is:	
Name of the Deceased or Legally Incapacitated Inventor : <input type="text"/>	
If the Assignee is an Organization check here. <input checked="" type="checkbox"/>	
Organization Name	COLIBRI HEART VALVE LLC

Under the Paperwork Reduction Act of 1995, no persons are required to respond to a collection of information unless it contains a valid OMB control number.

<b>Application Data Sheet 37 CFR 1.76</b>		Attorney Docket Number	109978.10101
		Application Number	
Title of Invention	PERCUTANEOUSLY IMPLANTABLE REPLACEMENT HEART VALVE DEVICE AND METHOD OF MAKING SAME		

<b>Mailing Address Information:</b>			
Address 1	2150 W. 6th Ave., Unit M		
Address 2			
City	Broomfield	State/Province	CO
Country <sup>i</sup>	US	Postal Code	80020
Phone Number		Fax Number	
Email Address			
Additional Applicant Data may be generated within this form by selecting the Add button.			<input type="button" value="Add"/>

**Signature:**

NOTE: This form must be signed in accordance with 37 CFR 1.33. See 37 CFR 1.4 for signature requirements and certifications					
Signature	/ Mark L. Yaskanin /		Date (YYYY-MM-DD)	2012-11-13	
First Name	Mark	Last Name	Yaskanin	Registration Number	45246
Additional Signature may be generated within this form by selecting the Add button.				<input type="button" value="Add"/>	

This collection of information is required by 37 CFR 1.76. The information is required to obtain or retain a benefit by the public which is to file (and by the USPTO to process) an application. Confidentiality is governed by 35 U.S.C. 122 and 37 CFR 1.14. This collection is estimated to take 23 minutes to complete, including gathering, preparing, and submitting the completed application data sheet form to the USPTO. Time will vary depending upon the individual case. Any comments on the amount of time you require to complete this form and/or suggestions for reducing this burden, should be sent to the Chief Information Officer, U.S. Patent and Trademark Office, U.S. Department of Commerce, P.O. Box 1450, Alexandria, VA 22313-1450. DO NOT SEND FEES OR COMPLETED FORMS TO THIS ADDRESS. **SEND TO: Commissioner for Patents, P.O. Box 1450, Alexandria, VA 22313-1450.**



## Privacy Act Statement

The Privacy Act of 1974 (P.L. 93-579) requires that you be given certain information in connection with your submission of the attached form related to a patent application or patent. Accordingly, pursuant to the requirements of the Act, please be advised that: (1) the general authority for the collection of this information is 35 U.S.C. 2(b)(2); (2) furnishing of the information solicited is voluntary; and (3) the principal purpose for which the information is used by the U.S. Patent and Trademark Office is to process and/or examine your submission related to a patent application or patent. If you do not furnish the requested information, the U.S. Patent and Trademark Office may not be able to process and/or examine your submission, which may result in termination of proceedings or abandonment of the application or expiration of the patent.

The information provided by you in this form will be subject to the following routine uses:

1. The information on this form will be treated confidentially to the extent allowed under the Freedom of Information Act (5 U.S.C. 552) and the Privacy Act (5 U.S.C. 552a). Records from this system of records may be disclosed to the Department of Justice to determine whether the Freedom of Information Act requires disclosure of these records.
2. A record from this system of records may be disclosed, as a routine use, in the course of presenting evidence to a court, magistrate, or administrative tribunal, including disclosures to opposing counsel in the course of settlement negotiations.
3. A record in this system of records may be disclosed, as a routine use, to a Member of Congress submitting a request involving an individual, to whom the record pertains, when the individual has requested assistance from the Member with respect to the subject matter of the record.
4. A record in this system of records may be disclosed, as a routine use, to a contractor of the Agency having need for the information in order to perform a contract. Recipients of information shall be required to comply with the requirements of the Privacy Act of 1974, as amended, pursuant to 5 U.S.C. 552a(m).
5. A record related to an International Application filed under the Patent Cooperation Treaty in this system of records may be disclosed, as a routine use, to the International Bureau of the World Intellectual Property Organization, pursuant to the Patent Cooperation Treaty.
6. A record in this system of records may be disclosed, as a routine use, to another federal agency for purposes of National Security review (35 U.S.C. 181) and for review pursuant to the Atomic Energy Act (42 U.S.C. 218(c)).
7. A record from this system of records may be disclosed, as a routine use, to the Administrator, General Services, or his/her designee, during an inspection of records conducted by GSA as part of that agency's responsibility to recommend improvements in records management practices and programs, under authority of 44 U.S.C. 2904 and 2906. Such disclosure shall be made in accordance with the GSA regulations governing inspection of records for this purpose, and any other relevant (i.e., GSA or Commerce) directive. Such disclosure shall not be used to make determinations about individuals.
8. A record from this system of records may be disclosed, as a routine use, to the public after either publication of the application pursuant to 35 U.S.C. 122(b) or issuance of a patent pursuant to 35 U.S.C. 151. Further, a record may be disclosed, subject to the limitations of 37 CFR 1.14, as a routine use, to the public if the record was filed in an application which became abandoned or in which the proceedings were terminated and which application is referenced by either a published application, an application open to public inspections or an issued patent.
9. A record from this system of records may be disclosed, as a routine use, to a Federal, State, or local law enforcement agency, if the USPTO becomes aware of a violation or potential violation of law or regulation.

PERCUTANEOUSLY IMPLANTABLE REPLACEMENT HEART VALVE  
DEVICE AND METHOD OF MAKING SAME

CONTINUITY INFORMATION

[0001] The present application is a continuation application of U.S. Patent Application No. 10/887,688 filed on July 10, 2004, now U.S. Patent No. 8,308,797, which is a continuation-in-part application of U.S. Patent Application No. 10/037,266, filed on January 4, 2002 (now abandoned). Both applications of which are incorporated herein by reference in their entireties.

BACKGROUND OF THE INVENTION

[0002] Field of the Invention

The present invention is in the field of heart valve replacement. More specifically, the present invention is directed to a method of making a percutaneously implantable replacement heart valve.

[0003] 2. Description of Related Art

There have been numerous efforts in the field of heart valve replacement to improve both the durability and effectiveness of replacement heart valves as well as the ease of implantation. A brief description of heart valves and heart function follows to provide relevant background for the present invention.

[0004] There are four valves in the heart that serve to direct the flow of blood through the two sides of the heart in a forward direction. On the left (systemic) side of the heart are: 1) the mitral valve, located between the left atrium and the left ventricle, and 2) the aortic valve, located between the left ventricle and the aorta. These two valves direct oxygenated blood coming from the lungs through the left side of the heart into the aorta for distribution to the body.

On the right (pulmonary) side of the heart are: 1) the tricuspid valve, located between the right atrium and the right ventricle, and 2) the pulmonary valve, located between the right ventricle and the pulmonary artery. These two valves direct de-oxygenated blood coming from the body through the right side of the heart into the pulmonary artery for distribution to the lungs, where it again becomes re-oxygenated to begin the circuit anew.

[0005] Heart valves are passive structures that simply open and close in response to differential pressures on either side of the particular valve. They consist of moveable “leaflets” that are designed simply to open and close in response to differential pressures on either side of the valve's leaflets. The mitral valve has two leaflets and the tricuspid valve has three. The aortic and pulmonary valves are referred to as “semilunar valves” because of the unique appearance of their leaflets, which are more aptly termed “cusps” and are shaped somewhat like a half-moon. The aortic and pulmonary valves each have three cusps.

[0006] In general, the components of heart valves include the valve annulus, which will remain as a roughly circular open ring after the leaflets of a diseased or damaged valve have been removed; leaflets or cusps; papillary muscles which are attached at their bases to the interior surface of the left or right ventricular wall; and multiple chordae tendineae, which couple the valve leaflets or cusps to the papillary muscles. There is no one-to-one chordal connection between the leaflets and the papillary muscles; instead, numerous chordae are present, and chordae from each papillary muscle attach to both of the valve leaflets.

[0007] When the left ventricular wall relaxes so that the ventricular chamber enlarges and draws in blood, the leaflets of the mitral valve separate and the valve opens. Oxygenated blood flows in a downward direction through the valve, to fill the expanding ventricular cavity. Once the left ventricular cavity has filled, the left ventricle contracts, causing a rapid rise in the left

ventricular cavity pressure. This causes the mitral valve to close while the aortic valve opens, allowing the oxygenated blood to be ejected from the left ventricle into the aorta. The chordae tendineae of the mitral valve prevent the mitral leaflets from prolapsing back into the left atrium when the left ventricular chamber contracts.

[0008] The three leaflets, chordae tendineae, and papillary muscles of the tricuspid valve function in a similar manner, in response to the filling of the right ventricle and its subsequent contraction. The cusps of the aortic valve also respond passively to pressure differentials between the left ventricle and the aorta. When the left ventricle contracts, the aortic valve cusps open to allow the flow of oxygenated blood from the left ventricle into the aorta. When the left ventricle relaxes, the aortic valve cusps reapproximate to prevent the blood which has entered the aorta from leaking (regurgitating) back into the left ventricle. The pulmonary valve cusps respond passively in the same manner in response to relaxation and contraction of the right ventricle in moving de-oxygenated blood into the pulmonary artery and thence to the lungs for re-oxygenation. Neither of these semilunar valves has associated chordae tendineae or papillary muscles.

[0009] Problems that can develop with heart valves consist of stenosis, in which a valve does not open properly, and/or insufficiency, also called regurgitation, in which a valve does not close properly. In addition to stenosis and insufficiency of heart valves, heart valves may need to be surgically repaired or replaced due to certain types of bacterial or fungal infections in which the valve may continue to function normally, but nevertheless harbors an overgrowth of bacteria (vegetation) on the leaflets of the valve that may embolize and lodge downstream in a vital artery. If such vegetations are on the valves of the left side (i.e., the systemic circulation side) of the heart, embolization may occur, resulting in sudden loss of the blood supply to the affected

body organ and immediate malfunction of that organ. The organ most commonly affected by such embolization is the brain, in which case the patient suffers a stroke. Thus, surgical replacement of either the mitral or aortic valve (left-sided heart valves) may be necessary for this problem even though neither stenosis nor insufficiency of either valve is present. Likewise, bacterial or fungal vegetations on the tricuspid valve may embolize to the lungs resulting in a lung abscess and therefore, may require replacement of the tricuspid valve even though no tricuspid valve stenosis or insufficiency is present.

[0010] These problems are treated by surgical repair of valves, although often the valves are too diseased to repair and must be replaced. If a heart valve must be replaced, there are currently several options available, and the choice of a particular type of artificial valve depends on factors such as the location of the valve, the age and other specifics of the patient, and the surgeon's experiences and preferences. Currently in the United States over 100,000 defective heart valves are replaced annually, at an approximate cost of \$30-50,000 per procedure, and thus it would be desirable if heart valves could be replaced using minimally invasive techniques and without having to repeat the procedure within a matter of years due to the lack of durability of the replacement heart valve. It would be especially advantageous if a defective heart valve could be removed via an endovascular procedure, that is, a procedure where the invasion into the body is through a blood vessel such as the femoral artery. The procedure is then carried out percutaneously and transluminally using the vascular system to convey appropriate devices to the position in the body wherein it is desired to carry out the desired procedure. An example of such a procedure would be angioplasty, wherein a catheter carrying a small balloon at its distal end is manipulated through the body's vessels to a point where there is a blockage in a vessel. The

balloon is expanded to create an opening in the blockage, and then the balloon is deflated and the catheter and balloon are removed from the vessel.

[0011] Endovascular procedures have substantial benefits both from the standpoint of health and safety as well as cost. Such procedures require minimal invasion of the human body, and there is consequently considerable reduction and in some instances even elimination, of the use of a general anesthesia and much shorter hospital stays.

[0012] Replacement heart valves can be categorized as either artificial mechanical valves, transplanted valves and tissue valves. Replacement heart valves are designed to optimize hemodynamic performance, thrombogenicity and durability. Another factor taken into consideration is the relative ease of surgical implantation.

[0013] Mechanical valves are typically constructed from nonbiological materials such as plastics, metals and other artificial materials which, while durable, are expensive and prone to blood clotting which increases the risk of an embolism. Anticoagulants taken to help against blood clotting can further complicate the patient's health due to increased risks for hemorrhages.

[0014] Transplanted valves are natural valves taken from cadavers. These valves are typically removed and frozen in liquid nitrogen, and are stored for later use. They are typically fixed in glutaraldehyde to eliminate antigenicity and are sutured in place, typically with a stent.

[0015] Artificial tissue valves are valves constructed from animal tissue, such as bovine or porcine tissue. Efforts have also been made at using tissue from the patient for which the valve will be constructed.

[0016] Most tissue valves are constructed by sewing the leaflets of pig aortic valves to a stent to hold the leaflets in proper position, or by constructing valve leaflets from the pericardial sac of cows or pigs and sewing them to a stent. The porcine or bovine tissue is chemically

treated to alleviate any antigenicity. The pericardium is a membrane that surrounds the heart and isolates it from the rest of the chest wall structures. The pericardium is a thin and very slippery, which makes it difficult for suturing in a millimetrically precise way. The method of making the replacement heart valve of the present invention solves this problem through a process that includes drying and compressing the pericardium using photo-mechanical compression in such a way that makes it possible to handle and fold the material more easily.

[0017] For example, one prior replacement heart valve requires each sculpted leaflet to be trimmed in a way that forms an extended flap, which becomes a relatively narrow strand of tissue near its tip. The tip of each pericardial tissue strand is sutured directly to a papillary muscle, causing the strand to mimic a chordae tendineae. Each strand extends from the center of a leaflet in the valve, and each strand is sutured directly to either an anterior and posterior papillary muscle. This requires each leaflet to be positioned directly over a papillary muscle. This effectively rotates the leaflets of the valve about 90 degrees as compared to the leaflets of a native valve. The line of commissure between the leaflets, when they are pressed together during systole, will bisect (at a perpendicular angle) an imaginary line that crosses the peaks of the two papillary muscles, instead of lying roughly along that line as occurs in a native valve.

[0018] A different approach to creating artificial tissue valves is described in U.S. Pat. No. 5,163,955 to Calvin, *et al.* and U.S. Pat. Nos. 5,571,174 and 5,653,749 to Love. Using a cutting die, the pericardial tissue is cut into a carefully defined geometric shape, treated with glutaraldehyde, then clamped in a sandwich-fashion between two stent components. This creates a tri-leaflet valve that resembles an aortic or pulmonary valve, having semilunar-type cusps rather than atrioventricular-type leaflets.

[0019] U.S. Pat. No. 3,671,979 to Mouloupoulos describes an endovascularly inserted conical shaped umbrella-like valve positioned and held in place by an elongated mounting catheter at a supra-annular site to the aortic valve in a nearby arterial vessel. The conical end points toward the malfunctioning aortic valve and the umbrella's distal ends open up against the aorta wall with reverse blood flow, thereby preventing regurgitation.

[0020] U.S. Pat. No. 4,056,854 to Boretos describes an endovascularly inserted, catheter mounted, supra-annular valve in which the circular frame abuts the wall of the artery and attached flaps of flexible membrane extend distally in the vasculature. The flaps lie against the artery wall during forward flow, and close inward towards the central catheter to prevent regurgitation during reverse blood flow. The Boretos valve was designed to be positioned against the artery wall during forward flow, as compared to the mid-center position of the Mouloupoulos valve, to reduce the stagnation of blood flow and consequent thrombus and embolic formation expected from a valve at mid-center position.

[0021] The main advantage of tissue valves is that they do not cause blood clots to form as readily as do the mechanical valves, and therefore, they do not absolutely require systemic anticoagulation. The major disadvantage of tissue valves is that they lack the long-term durability of mechanical valves. Tissue valves have a significant failure rate, usually within ten years following implantation. One cause of these failures is believed to be the chemical treatment of the animal tissue that prevents it from being antigenic to the patient. In addition, the presence of extensive suturing prevents the artificial tissue valve from being anatomically accurate in comparison to a normal heart valve, even in the aortic valve position.

[0022] A shortcoming of prior artificial tissue valves has been the inability to effectively simulate the exact anatomy of a native heart valve. Although transplanted human or porcine



aortic valves have the gross appearance of native aortic valves, the fixation process (freezing with liquid nitrogen, and chemical treatment, respectively) alters the histologic characteristics of the valve tissue. Porcine and bovine pericardial valves not only require chemical preparation (usually involving fixation with glutaraldehyde), but the leaflets must be sutured to cloth-covered stents in order to hold the leaflets in position for proper opening and closing of the valve. Additionally, the leaflets of most such tissue valves are constructed by cutting or suturing the tissue material, resulting in leaflets that do not duplicate the form and function of a real valve and are more susceptible to failure.

#### SUMMARY OF THE INVENTION

[0023] The present invention is a replacement heart valve device and method of making same. The replacement heart valve device, in a preferred embodiment, comprises a stent made of stainless steel or self-expanding nitinol and a completely newly designed artificial biological tissue valve disposed within the inner space of the stent. The cusp or leaflet portion of the valve means is formed by folding of the pericardium material preferably used to create the valve without cutting of slits to form leaflets or suturing or otherwise affixing of separate leaflet portions. Other forms of tissue and suitable synthetic materials can also be used for the valve, formed in a sheet of starting material. The folded design provides a number of advantages over prior designs, including improved resistance to tearing at suture lines. The cusps/leaflets open in response to blood flow in one direction and close in response to blood flow in the opposite direction. Preferably the tubular portion of the valve means contains the same number of cusps as the native valve being replaced, in substantially the same size and configuration. The outer surface of the valve means is attached to the stent member.

[0024] The replacement heart valve device is preferably implanted using a delivery system having a central part which consists of a flexible hollow tube catheter that allows a metallic guide wire to be advanced inside it. The stented valve is collapsed over the central tube and it is covered by a movable sheath. The sheath keeps the stented valve in the collapsed position. Once the cover sheath is moved backwards, the stented valve can be deployed. The endovascular stented-valve, in a preferred embodiment, is a glutaraldehyde fixed mammal pericardium or synthetic biocompatible material which has two or three cusps that open distally to permit unidirectional blood flow. The stent can either be self-expanding or the stent can be expandable through use of a balloon catheter.

[0025] The present invention also comprises a method of making a replacement heart valve device. In order to make the valve, the pericardium starting material is isolated and all the fat tissue and extra fibers are removed. The biological membrane material is cleaned by mechanical separation of unwanted layers using hydromechanical force means. Once the pericardium is completely clean, the material is dried in order to make it easier to handle and fold. Preferably, this drying is done by exposing the biocompatible membrane material to photo-mechanical compression to remove all lipids from the pericardium or other biocompatible membrane material and to cause protein denaturalization, transforming the material into a stronger and more homogeneous surface. The valve is formed by taking a flat sheet of the material and folding in such a way that forms a three-leaflet or other number of leaflet valve. Then it is placed in a sequence of solutions, one of isopropyl alcohol of about 70-100%, one of ethanol of about 70-100%, one of glycerol and one of glutaraldehyde, preferably at a concentration of about 0.07-25% for approximately 36 hours. The material is dried in order to make it easier to handle and fold. Preferably this drying is done by exposing the biocompatible

membrane material to light and then mechanically compressing the material to cause protein denaturation. This results in material that is stronger and more homogeneous. The valve is formed by taking a flat sheet of bovine or porcine pericardium and folding it in such a way that forms a three-leaflet valve. The valve can also be made in the same manner from fresh, cryopreserved or glutaraldehyde fixed allografts or xenografts or synthetic non-biological, non-thrombogenic material. The folding of the pericardium material to create the cusps or leaflets reduces the extent of suturing otherwise required, and resembles the natural form and function of the valve leaflets. The cleaning, pressing and drying technique used to create the valve material makes the folding more practicable. The valve is rehydrated after being formed. The method of the present invention also greatly reduces the risk of tearing of the cusps or leaflets, since they are formed by folding a single uncut portion of material forming the valve rather than being attached by suturing.

[0026] Once the endovascular implantation of the prosthetic valve device is completed in the host, the function of the prosthetic valve device can be monitored by the same methods as used to monitor valve replacements done by open heart surgery. Routine physical examination, periodic echocardiography or angiography can be performed. In contrast to open heart surgery, however, the host requires a short recovery period and can return home within one day of the endovascular procedure. The replacement heart valve device of the present invention can be used in any patient where bioprosthetic valves are indicated, namely elderly patients with cardiac valve diseases, and patients unable to tolerate open heart procedures or life-long anticoagulation medication and treatment. The present invention can be practiced in applications with respect to each of the heart's valves.

## BRIEF DESCRIPTION OF THE DRAWINGS

[0027] FIG. 1 depicts a side perspective view of the replacement heart valve device of the present invention in one embodiment with the valve in the closed position.

[0028] FIG. 2 depicts the folds which form the leaflets or cusps of the replacement heart valve of the present invention in one embodiment.

[0029] FIGS. 3A and 3B depict a preferred procedure for folding the pericardium tissue starting material to create the replacement heart valve of the present invention.

[0030] FIG. 4 depicts a side perspective view of the replacement heart valve device of the present invention in one embodiment represented as if implanted within an artery.

[0031] FIG. 5 depicts a side view of one embodiment of the replacement heart valve device of the present invention mounted within a self-expanding stent, with the stent in the expanded position.

[0032] FIG. 6 depicts a side perspective view of one embodiment of the replacement heart valve device of the present invention mounted within a self-expanding stent in the collapsed position.

[0033] FIG. 7 depicts the suture points of one embodiment of the replacement heart valve device of the present invention.

[0034] FIG. 8 depicts the implantation/delivery system used with the present invention in a preferred embodiment.

[0035] FIGS. 9A, 9B and 9C depict a representation of a sheet of biocompatible valve material showing preferred folds.

## DESCRIPTION OF A PREFERRED EMBODIMENT

[0036] The present invention comprises a percutaneously implantable replacement heart valve and a method for making same. The artificial heart valve device of the present invention is capable of exhibiting a variable diameter between a compressed or collapsed position and an expanded position. A preferred embodiment of the replacement heart valve device according to the present invention is set forth in FIG. 5. The replacement heart valve device comprises a stent member 100 and a flexible valve means 200. The stent member 100 is preferably self-expanding, although balloon-expandable stents can be used as well, and has a first polygonal shape in its compressed or collapsed configuration and a second, larger polygonal shape in its expanded configuration. Referring to FIG. 1, the valve means 200 comprises a generally tubular portion 210 and, preferably, a peripheral upstanding cusp or leaflet portion 220. The valve means 200 is disposed within the cylindrical stent member 100 with the tubular portion 210 transverse of and at some acute angle relative to the stent walls. The diameter of the tubular portion 210 is substantially the same as the inside diameter of the stent member in its initial expanded configuration. The peripheral upstanding cusp or leaflet portion 220 is disposed on valve means 200 substantially parallel to the walls of the stent member similar to a cuff on a shirt. The cusp or leaflet portion 220 of the valve means 200 is generally tubular in shape and comprises three leaflets 221, 222 and 223 as shown, although it is understood that there could be from two to four leaflets. The tubular portion of the valve means 200 is attached to the stent member 100 by a plurality of sutures 300, as depicted in FIG. 7.

[0037] The leaflet portion 220 of the valve means 200 extends across or transverse of the cylindrical stent 100. The leaflets 221, 222 and 223 are the actual valve and allow for one-way flow of blood. The leaflet portion 220 as connected to the rest of the valve resembles the cuff of

a shirt. FIG. 9 depicts the folds preferred for valve cusp and leaflet formation involving three leaflets. The configuration of the stent member 100 and the flexible, resilient material of construction allows the valve to collapse into a relatively small cylinder as seen in FIG. 6. The replacement heart valve will not stay in its collapsed configuration without being restrained. Once the restraint is removed, the self-expanding stent member 100 will cause the artificial heart valve to take its expanded configuration, as seen in FIG. 5.

### **Stent Member**

[0038] The stent member 100 preferably comprises a self-expanding nickel-titanium alloy stent, also called “nitinol,” in a sine wave-like configuration as shown in FIG. 5. An enlarged view of a preferred embodiment of the stent member for use in the replacement heart valve of the invention is depicted in FIG. 5. The stent member 100 includes a length of wire 110 formed in a closed zigzag configuration. The wire can be a single piece, stamped or extruded, or it could be formed by welding the free ends together. The straight sections of the stent member 100 are joined by bends. The stent is readily compressible to a small cylindrical shape as depicted in FIGS. 6 and 8, and resiliently self-expandable to the shape shown in FIG. 5.

[0039] The stent member 100 of the artificial heart valve device of the present invention may be made from various metal alloys, titanium, titanium alloy, nitinol, stainless steel, or other resilient, flexible non-toxic, non-thrombogenic, physiologically acceptable and biocompatible materials. The configuration may be the zigzag configuration shown or a sine wave configuration, mesh configuration or a similar configuration which will allow the stent to be readily collapsible and self-expandable. When a zigzag or sine wave configured stent member is used, the diameter of the wire from which the stent is made is preferably from about 0.010 to 0.035 inches and still, preferably from about 0.012 to 0.025 inches. The diameter of the stent

member will be from about 1.5 to 3.5 cm, preferably from about 1.75 to 3.00 cm, and the length of the stent member will be from about 1.0 to 10 cm, preferably from about 1.1 to 5 cm.

[0040] The stent used in a preferred embodiment of the present invention is fabricated from a “shaped memory” alloy, nitinol, which is composed of nickel and titanium. Nitinol wire is first fashioned into the desired shape for the device and then the device is heat annealed. A meshwork of nitinol wire of approximately 0.008 inch gauge is formed into a tubular structure with a minimum central diameter of 20 min to make the stent. Away from its central portion, the tubular structure flares markedly at both ends in a trumpet-like configuration. The maximum diameter of the flared ends of the stent is approximately 50 mm. The purpose of the stent is to maintain a semi-rigid patent channel through the diseased cardiac valve following its implantation.

[0041] When the components of the replacement heart valve device are exposed to cold temperatures, they become very flexible and supple, allowing them to be compressed down and pass easily through the delivery sheath. A cold temperature is maintained within the sheath during delivery to the deployment site by constantly infusing the sheath with an iced saline solution. Once the valve components are exposed to body temperature at the end of the sheath, they instantaneously reassume their predetermined shapes, thus allowing them to function as designed.

[0042] Preferably the stent member 100 carries a plurality of barbs extending outwardly from the outside surface of the stent member for fixing the heart valve device in a desired position. More preferably the barbs are disposed in two spaced-apart, circular configurations with the barbs in one circle extending in an upstream direction and the barbs in the other circle extending in a downstream direction. It is especially preferable that the barbs on the inflow side

of the valve point in the direction of flow and the barbs on the outflow side point in the direction opposite to flow. It is preferred that the stent be formed of titanium alloy wire or other flexible, relatively rigid, physiologically acceptable material arranged in a closed zigzag configuration so that the stent member will readily collapse and expand as pressure is applied and released, respectively.

#### **Valve Means**

[0043] The valve means 200 is flexible, compressible, host-compatible, and non-thrombogenic. The valve means 200 can be made from various materials, for example, fresh, cryopreserved or glutaraldehyde fixed allografts or xenografts. Synthetic biocompatible materials such as polytetrafluoroethylene, polyester, polyurethane, nitinol or other alloy/metal foil sheet material and the like may be used. The preferred material for the valve means 200 is mammal pericardium tissue, particularly juvenile-age animal pericardium tissue. The valve means 200 is disposed within the cylindrical stent member 100 with the tubular portion 210 transverse of and at some acute angle relative to the stent walls. The diameter of the tubular portion 210 is substantially the same as the inside diameter of the stent member 100 in its initial expanded configuration. The peripheral upstanding cusp or leaflet portion 220 is disposed substantially parallel to the walls of the stent member 100 similar to a cuff on a shirt.

[0044] The cusp or leaflet portion 220 of the valve means 200 is formed by folding of the pericardium material used to create the valve. FIGS. 3A and 3B depict the way the sheet of heart valve starting material is folded. The starting material is preferably a flat dry sheet, which can be rectangular or other shaped. The cusps/leaflets 221, 222 and 223 open in response to blood flow in one direction and close in response to blood flow in the opposite direction. Preferably the cusp or leaflet portion 220 of the valve means 200 contains the same number of cusps as the



native valve being replaced, in substantially the same size and configuration. FIGS. 9A-9C depict a preferred configuration for folds to create the leaflets/cusps. The leaflet forming portion is a single, continuous, uncut layer affixed to the interior of the cuff layer to form the leaflets/cusps, unlike prior efforts that have involved suturing of three separate leaflet/cusp portions onto the main valve body portion. The leaflets are formed from the free edge of the material after forming the cuff portion. Referring now to FIGS. 9-A, 9B, and 9C, with flat sheet on a table, a person facing the sheet would create a cuff at the upper border of sheet by folding the horizontal top edge away/downwardly (fold no. 1). The leaflet portion is formed by folding the sheet's lower half towards the folder/upwardly, as shown in FIG. 9A (fold no. 2). The sheet, now with the upper cuff and bottom inward fold, is folded inwardly at two preferably equidistant vertical points as shown in FIG. 9B to create the leaflet/cusp portion (folds nos. 3 and 4). The leaflets/cusps are formed by folding fold nos. 6, 7 and 8 after the two opposite vertical edges of sheet are joined to create a cylindrical valve shape, depicted in FIGS. 1 and 3B. The inner leaflet layer is preferably attached to the outer cuff layer by curved or straight continuous suturing. Although a preferred embodiment of the invention comprises a single piece of valve material folded to create the valve body and a leaflet-forming portion that has no cuts or sutures, the inventors have discovered that as long as the leaflet portion of the valve itself is formed from a single piece of biocompatible valve material, the other portions of the valve can be formed by suturing of one or more separate pieces of material without losing the novel and improved qualities of the present invention. This allows for the valve to be made even stronger, more durable and easier to make. This alternate embodiment comprises a leaflet forming layer made of a single piece of valve material attached to a separate piece forming the valve body having a folded cuff portion. The single piece leaflet forming layer is preferably cylindrical in shape and

can be formed with or without folding. In this embodiment the single piece leaflet layer can itself be attached to the stent with or without a cylindrical cuff portion. Attachment is preferably by suturing, particularly continuous single or double sutures.

#### **Method of Making Replacement Heart Valve Device**

[0045] The present invention also comprises a method of making a replacement heart valve device. In order to make the valve, the biocompatible tissue material is isolated and all the fat tissue and extra fibers are removed. Cleaning is preferably accomplished by using a hydromechanical force-based cleaning device to separate tissue layers and hydration with distilled water to remove unwanted layers. Once the pericardium is completely clean, it is subjected to photo-mechanical compression, then the valve is formed and placed in sequential solutions of isopropyl alcohol of about 70-100%, ethanol of about 70-100% glycerol and glutaraldehyde preferably at a concentration of about 0.07-25% for about 36 hours, respectively. The material is preferably photomechanically compressed to remove lipids and produce protein coagulation to make the surface smoother and more compact and biocompatible, decreasing the molecular distance of collagen fibers. The exposure to light and mechanical compression cause protein denaturation making the material stronger and more homogeneous and biocompatible. Gas sterilization can also be used to sterilize the tissue membrane material. The valve is formed by taking a flat sheet of the material and folding it in such a way that forms a three-leaflet or desired number of leaflet valve as shown in FIGS. 3A and 3B and/or FIGS. 9A, 9B and 9C. The folding of the pericardium material to create the cusps or leaflets reduces the extent of suturing otherwise required, and resembles the natural form and function of the valve leaflets. It also greatly reduces the risk of tearing of the cusps or leaflets, since they are integral to the valve rather than being attached by suturing.

[0046] In a preferred embodiment, the single continuous piece of membrane is folded inward to form an inner leaflet layer within the outer cuff. The single leaflet layer is then attached to the cuff layer to form valve cusps in one of three preferred ways: (i) by curved or straight continuous single or double sutures that affix and form the bases or recesses of the valve cusps; (ii) by lengthwise suture lines attaching the leaflet layer to the cuff layer with the bases or recesses of the valve cusps being thus formed of the folded edge of the membrane; (iii) by further folding of the membrane into lengthwise pleats secured by lengthwise suture attaching the leaflet layer to the cuff layer with the bases or recesses of the valve cusps being thus formed of the folded edge of the membrane, done for the purpose of giving greater strength and durability to the attachment points of the leaflet layer.

[0047] In order to make the pericardium material less slippery and easier to fold, the pericardium is dried, preferably with artificial light using a multi-watt lamp with the pericardium or other biocompatible membrane material placed in a flat aluminum surface to dry it homogeneously. A photomechanical drying machine can also be used. The final result is a homogeneous tissue that looks like plastic paper and makes it easy to manipulate to fold and suture the valve. Once the valve is formed, it is re-hydrated by placing it in a solution of water and 70% alcohol. In approximately 3 days the valve is fully rehydrated. The suturing of membrane layers to form the valve is done with single, double, or more continuous suture material. This form of suturing has great advantages for durability and avoidance of damage to the membrane and can be performed by sewing machines. The attachment points of the leaflet layer to the cuff layer may be reinforced by folding an additional layer of membrane over the attachment point before suturing, this layer being formed of a projected tab of the continuous piece of leaflet membrane. The free edge of the leaflet layer may be straight or curved, and this

free edge forming the free edges of the individual leaflets may be contoured in parabolic or curved shape.

#### **Attachment of the Valve Means to the Stent Member**

[0048] The valve means 200 is then attached to the inner channel of the stent member 100 by suturing the outer surface of the valve means' pericardium material to the stent member. FIG. 7 depicts preferred suture points of one embodiment of the present invention: 3-point fixation or 6-point fixation at each border of the stent. Other fixation schemes can be utilized, such as, by way of non-limiting example, fixation on both borders 18 points at each end following a single plane and 36 fixation points following to adjacent vertical planes. The use of only one plane of fixation points helps prevent systolic collapse of the proximal edge of the valve means. A fold on the border of the pericardium material prevents tearing. The attachment position of the valve is preferably closer to the proximal and wider part of the stent.

[0049] The sequence of steps can vary. The pericardium material can be fixed in glutaraldehyde before attachment to the stent or the valve can be formed and then fixed with glutaraldehyde after mounting it in the stent. One observation noted is that the material becomes whiter and apparently increases its elasticity. 1 mm vascular clips keep the cusps coapted while fixing them in glutaraldehyde. The use of metallic clips to keep both cusps adjacent to each other after 24 hours of fixation in glutaraldehyde helps to educate the material and make the primary position of the valve cusps adjacent to each other. After the clips are removed, there are no lesions to the valve.

[0050] Different suture materials can be used, including, in a preferred embodiment, Prolene 1-0 to 8-0 and Mersilene 1-0 to 8-0 which is a braided suture.

## **Implantation of Replacement Heart Valve Device**

[0051] The replacement heart valve device of the present invention is preferably used in surgical procedures involving the percutaneous and transluminal removal of the diseased or defective heart valve and the percutaneous and transluminal implantation of the new heart valve described above. The defective heart valve is removed by a suitable modality, such as, for example, laser, ultrasound, mechanical, or other suitable forms of delivery of energy, or phacoemulsion, including, but not limited to, laser lithotripsy, mechanical lithotripsy, electrohydraulic lithotripsy, and laser or mechanical ablation. To remove the native heart valve that is being replaced, a guidewire is inserted percutaneously and transluminally using standard vascular or angiography techniques. The distal end of the guidewire is manipulated to extend through and across the defective heart valve. Then a catheter is advanced distally through the femoral artery to a point proximal to the defective heart valve, between the origin of the coronary artery and the origin of the right subclavian artery. The position of the distal end of catheter can be monitored by observation of radiopaque markers. Collector member is preferably inflated and occludes the aorta at a point between the origin of the coronary artery and the right subclavian artery. Next, a balloon and cutting tool are advanced through the catheter so that the cutting tool and uninflated balloon are distal to the defective heart valve. Optionally an additional step, such as balloon dilatation or atherectomy, may be required to provide a passageway through the heart valve. A catheter is also placed into the coronary sinus via a transjugular puncture. This catheter is used for infusion of blood or cardioplegia solution during the portion of the procedure when the aorta is occluded. The absence of valves in the cardiac venous system allows retrograde flow so that there will be an effluence of fluid from the coronary arteries. This flow of fluid is desired to prevent embolization of material into the coronary arteries during the procedure. Once the

cutting tool is in place, the balloon is inflated and flexible shaft is rotated. Once the cutting tool has reached the appropriate rotation speed, the cutting tool is pulled proximally to remove the defective heart valve. The balloon and the cutting tool are spaced apart so that the inflated balloon will be stopped by the perimeter, unremoved portion of the defective heart valve, which will signal the physician that the valve has been removed, as well as protect the heart and aorta from damage from the valve removal device. Once it is determined that the defective heart valve has been removed, the cutting tool is slowed or stopped altogether and the balloon is deflated. The cutting tool and the deflated balloon are pulled proximally through catheter. Then, a catheter containing an artificial heart valve is inserted and the artificial heart valve is placed as described above.

[0052] The delivery and implantation system of the replacement artificial heart valve of the present invention percutaneously and transluminally includes a flexible catheter 400 which may be inserted into a vessel of the patient and moved within that vessel as depicted in FIG. 8. The distal end 410 of the catheter 400, which is hollow and carries the replacement heart valve device of the present invention in its collapsed configuration, is guided to a site where it is desired to implant the replacement heart valve. The catheter has a pusher member 420 disposed within the catheter lumen 430 and extending from the proximal end 440 of the catheter to the hollow section at the distal end 410 of the catheter. Once the distal end 410 of the catheter is positioned as desired, the pusher mechanism 420 is activated and the distal portion of the replacement heart valve device is pushed out of the catheter and the stent member 100 partially expands. In this position the stent member 100 is restrained so that it doesn't pop out and is held for controlled release, with the potential that the replacement heart valve device can be recovered if there is a problem with the positioning. The catheter 400 is then retracted slightly and the

replacement heart valve device is completely pushed out of the catheter 400 and released from the catheter to allow the stent member 100 to fully expand. If the stent member 100 preferably includes two circles of barbs on its outer surface as previously described, the first push and retraction will set one circle of barbs in adjacent tissue and the second push and release of the replacement heart valve device will set the other circle of barbs in adjacent tissue and securely fix the replacement heart valve device in place when the device is released from the catheter.

[0053] Alternatively, or in combination with the above, the replacement heart valve device could be positioned over a metallic guidewire that is advanced through the catheter. The replacement heart valve device of the present invention is preferably implanted percutaneously through an aortic passageway to, or near to, the location from which the natural heart valve has been removed. Referring to FIG. 8, the implantation system comprises a flexible hollow tube catheter 410 with a metallic guide wire 450 disposed within it. The stented valve device is collapsed over the tube and is covered by a moveable sheath 460. The moveable sheath 460 maintains the stented valve device in the collapsed position. The implantation method comprises the following steps: inserting the replacement heart valve device in the lumen of a central blood vessel via entry through the brachial or femoral artery using a needle or exposing the artery surgically; placing a guide wire 450 through the entry vessel and advancing it to the desired position; advancing dilators over the wire to increase the lumen of the entry site, thereby preparing the artery to receive the heart-valve; and advancing the heart-valve device to the desired place. The stented-valve device is released by pulling the cover sheath 460 of the delivery system allowing the self-expanding stent to achieve its full expansion. A balloon expandable stent can alternately be used to deliver the valve to its desired position. At this point,

a pigtail catheter is advanced over the wire and an aortogram is performed to assess the competency of the valve.

[0054] Before creation of the valve means and implantation, the patient is studied to determine the architecture of the patient's heart. Useful techniques include fluoroscopy, transesophageal echocardiography, MRI, and angiography. The results of this study will enable the physician to determine the appropriate size for the replacement heart valve.

[0055] In one procedure for implantation of the replacement heart valve device of the present invention, the femoral artery of the patient is cannulated using a Cook needle and a standard J wire is advanced into the artery either percutaneously or after surgical exposure of the artery. An 8 F introducer is advanced into the femoral artery over the wire. The J wire is then withdrawn and anticoagulation is started using heparin 60 U/Kg intravenously. Once vascular access is obtained an aortogram is performed for anatomical evaluation. A special wire (Lunderquist or Amplatz superstiff) is advanced into the aortic arch and dilators progressively larger are advanced over the wire, starting with 12 F all the way to 18 F. After this the valve introducer device containing the prosthetic valve device is then inserted and used to transport the replacement valve over a guidewire to the desired position. The stented-valve is released by pulling the cover sheath of the delivery system allowing the self-expanding stent to achieve its full expansion. At this point, a pigtail catheter is advanced over the wire and repeat aortogram is performed to assess the competency of the valve.

[0056] When the device is used to treat severe leakage of the aortic valve, the native valve is left in place and the prosthetic stented valve is deployed below the subclavian artery. When the device is used to treat aortic stenosis, first the stenotic valve needs to be opened using



either aortic valvuloplasty or cutting and if this procedure induces aortic insufficiency the stented valve is placed to prevent the regurgitation.

[0057] Intravascular ultrasound or an angioscope passed intravascularly via either the venous system through the intra-atrial septum across the mitral valve and into the left ventricle or retrograde via the femoral artery would provide the added benefit of allowing constant high definition imaging of the entire procedure and high flow irrigation.

[0058] Once the endovascular implantation of the prosthetic valve device is completed in the host, the function of the prosthetic valve device can be monitored by the same methods as used to monitor valve replacements done by open heart surgery. Routine physical examination, periodic echocardiography or angiography can be performed. In contrast to open heart surgery, however, the host requires a short recovery period and can return home within one day of the endovascular procedure. The prosthetic valve device can be used in any patient where bioprosthetic valves are indicated, namely elderly patients with cardiac valve diseases, and patients unable to tolerate open heart procedures or life-long anticoagulation. In addition, with the development of longer-life, flexible, non-thrombogenic synthetic valve alternatives to bioprosthesis, the prosthetic valve device will be indicated in all patients where the relative advantages of the life-span, the non-thrombogenic quality, and the ease of insertion of prosthetic valve devices outweigh the disadvantages of mechanical valves. Anticoagulation may be beneficial in certain clinical situations for either short or long term use.

[0059] This method of percutaneous endovascular heart-valve replacement, in contrast to open heart surgical procedures, requires only local anesthesia, partial or no cardiac bypass, one to two days hospitalization, and should result in a reduced mortality rate as compared to open heart procedures.

[0060] While the present invention has been shown and described herein in what is considered to be a preferred embodiment thereof, illustrating the results and advantages over the prior art obtained through the present invention, the invention is not limited to the specific embodiments described above. Thus, the forms of the invention shown and described herein are to be taken as illustrative and other embodiments may be selected without departing from the spirit and scope of the present invention.

## CLAIMS

What is claimed is:

1. A percutaneously implantable replacement heart valve device comprising an expandable stent member and a flexible, compressible artificial valve made of biocompatible tissue material and disposed within the inner cavity of said stent member affixed at one or more points on said artificial valve's outer surface to said stent member, said artificial valve having cusps or leaflets formed by folding of a sheet of said biocompatible tissue material without affixing of separate cusps or leaflets or cutting slits into said material to form said cusps or leaflets.
2. The percutaneously implantable replacement heart valve device of claim 1, wherein said expandable stent member is made of a metal or alloy of metals selected from the group consisting of nickel-titanium alloy, titanium and stainless steel.
3. The percutaneously implantable replacement heart valve device of claim 1, wherein said biocompatible tissue material of said artificial valve comprises mammal pericardium tissue.
4. The percutaneously implantable replacement heart valve device of claim 1, wherein said biocompatible tissue material of said artificial valve comprises porcine pericardium tissue.

5. The percutaneously implantable replacement heart valve device of claim 1, wherein said biocompatible tissue material of said artificial valve is obtained from a juvenile animal pericardium.

6. The percutaneously implantable replacement heart valve device of claim 1, wherein said biocompatible tissue material of said artificial valve comprises autologous tissue obtained from the patient into whom said replacement heart valve device will be implanted.

7. The percutaneously implantable heart valve device of claim 1, wherein said biocompatible tissue material of said artificial valve comprises a synthetic biocompatible material.

8. The percutaneously implantable heart valve device of claim 7, wherein said synthetic biocompatible material is selected from the group consisting of polytetrafluoroethylene, polyester, metal, metal alloy including combinations thereof.

9. The percutaneously implantable heart valve device of claim 1, wherein said stent member is self-expanding when implanted.

10. The percutaneously implantable heart valve device of claim 1, wherein said stent member is balloon catheter expandable when implanted.

11. A method of making a percutaneously implantable replacement heart valve device comprising the following steps:

obtaining a sheet of biocompatible tissue material;

drying said biocompatible tissue material;

folding said dried biocompatible tissue material to create inner cusps or leaflets and an outer tubular cuff structure without affixing of separate cusps or leaflets or cutting slits into said material to form said cusps or leaflets;

affixing said folded biocompatible tissue material at one or more points on its outer surface to the inner cavity of a stent; and

soaking said biocompatible tissue material in one or more alcohol solutions and a solution of glutaraldehyde.

12. The method of making a percutaneously implantable replacement heart valve device of claim 11, wherein said soaking step comprises soaking said biocompatible tissue material in a solution of isopropyl alcohol, a solution of ethanol, a solution of glycerol and a solution of glutaraldehyde.

13. The method of making a percutaneously implantable replacement heart valve device of claim 11, wherein said biocompatible tissue material comprises bovine pericardium tissue.

14. The method of making a percutaneously implantable replacement heart valve device of claim 11, wherein said biocompatible tissue material comprises porcine pericardium tissue.

15. The method of making a percutaneously implantable replacement heart valve device of claim 11, wherein said biocompatible tissue material is obtained from a juvenile animal pericardium.

16. The method of making a percutaneously implantable replacement heart valve device of claim 11, wherein said biocompatible tissue material comprises autologous tissue obtained from the patient into whom said replacement heart valve device will be implanted.

17. The percutaneously implantable heart valve device of claim 11, wherein said biocompatible tissue material of said artificial valve comprises a synthetic biocompatible material.

18. The percutaneously implantable heart valve device of claim 17, wherein said synthetic biocompatible material is selected from the group consisting of polytetrafluoroethylene, polyester, metal, metal alloy including combinations thereof.

19. The method of making a percutaneously implantable replacement heart valve device of claim 11, wherein said stent is made of a metal or alloy of metals selected from the group consisting of nickel-titanium alloy, titanium and stainless steel.

20. The method of making a percutaneously implantable replacement heart valve device of claim 11, wherein said stent is self-expanding when implanted.

21. The method of making a percutaneously implantable replacement heart valve device of claim 11, wherein said stent is balloon catheter expandable when implanted.

22. The method of making a percutaneously implantable replacement heart valve device of claim 11, further comprising the step of cleaning said biocompatible tissue material using hydromechanical force means.

23. The method of making a percutaneously implantable replacement heart valve of claim 11, further comprising the step of compressing said biocompatible tissue material.

24. The method of making a percutaneously implantable replacement heart valve of claim 11, further comprising the step of gas sterilization of said biocompatible tissue material.

25. The method of making a percutaneously implantable replacement heart valve of claim 11, wherein said drying step comprises photomechanical compression of said biocompatible tissue material.

26. The method of making a percutaneously implantable replacement heart valve of claim 11, wherein said folding step comprises folding of a first piece of said biocompatible tissue material to create an outer tubular cuff structure, folding of a second separate piece of biocompatible tissue material to create inner cusps or leaflets without affixing of separate cusps or cutting slits into said second separate piece of biocompatible tissue material, and affixing said second separate piece to said first piece.

27. A percutaneously implantable replacement heart valve device comprising an expandable stent member and a flexible, compressible artificial valve made of biocompatible tissue material and disposed within the inner cavity of said stent member affixed at one or more points on said artificial valve's outer surface to said stent member, said artificial valve comprising a leaflet or cusp portion formed by folding of a first sheet portion of said biocompatible tissue material without affixing of separate cusps or leaflets or cutting slits into said sheet to form said cusps or leaflets, and an outer tubular cuff structure formed by folding a second sheet portion of biocompatible tissue material, said first and second sheet portions being affixed together.

28. The device of claim 27, wherein said first sheet portion and said second sheet portions are affixed together by suturing.

29. The device of claim 28, wherein said suturing is in the form of double continuous sutures.



30. A percutaneously implantable replacement heart valve device comprising an outer cylindrical cuff portion and an inner uncut/unslit leaflet layer attached within said outer cuff portion.

31. The device of claim 30, wherein said leaflet layer is attached within said outer cuff portion by suturing.

32. The device of claim 31, wherein said suturing is in the form of double continuous sutures.

33. A percutaneously implantable replacement heart valve device comprising an expandable stent member and a flexible, compressible artificial valve made of biocompatible tissue material and disposed within the inner cavity of said stent member affixed at one or more points on said artificial valve's outer surface to said stent member, said artificial valve comprising a leaflet or cusp portion formed by folding of a first sheet portion of said biocompatible tissue material without affixing of separate cusps or leaflets or cutting slits into said sheet to form said cusps or leaflets.

## ABSTRACT

A method of making a replacement heart valve device whereby a fragment of biocompatible tissue material is treated and soaked in one or more alcohol solutions and a solution of glutaraldehyde. The dried biocompatible tissue material is folded and rehydrated in such a way that forms a two- or three-leaflet/cusp valve without affixing of separate cusps or leaflets or cutting slits into the biocompatible tissue material to form the cusps or leaflets. After the biocompatible tissue material is folded, it is affixed at one or more points on the outer surface to the inner cavity or a stent.

## Electronic Acknowledgement Receipt

<b>EFS ID:</b>	14214529
<b>Application Number:</b>	13675665
<b>International Application Number:</b>	
<b>Confirmation Number:</b>	1995
<b>Title of Invention:</b>	PERCUTANEOUSLY IMPLANTABLE REPLACEMENT HEART VALVE DEVICE AND METHOD OF MAKING SAME
<b>First Named Inventor/Applicant Name:</b>	. .
<b>Customer Number:</b>	29880
<b>Filer:</b>	Mark Lauren Yaskanin/Carol Donahue
<b>Filer Authorized By:</b>	Mark Lauren Yaskanin
<b>Attorney Docket Number:</b>	109978.10101
<b>Receipt Date:</b>	13-NOV-2012
<b>Filing Date:</b>	
<b>Time Stamp:</b>	16:55:42
<b>Application Type:</b>	Utility under 35 USC 111(a)

### Payment information:

Submitted with Payment	no
------------------------	----

### File Listing:

Document Number	Document Description	File Name	File Size(Bytes)/ Message Digest	Multi Part /.zip	Pages (if appl.)
1	Drawings-only black and white line drawings	10101_drawings.PDF	124315 <small>6f30f1e22a1fae4e6cddf47cf4b112f8233328c0</small>	no	12

### Warnings:

### Information:

2	Application Data Sheet	10101_Application_Data_Sheet.PDF	873750 e2738135a634ce0c050731a2ff29acc09257986a	no	5
<b>Warnings:</b>					
<b>Information:</b>					
3		10101_CON_Application.pdf	147609 5a9a6e1fdd6bbb55e5c47e45b2bca70196df5473	yes	33
<b>Multipart Description/PDF files in .zip description</b>					
		<b>Document Description</b>	<b>Start</b>	<b>End</b>	
		Specification	1	25	
		Claims	26	32	
		Abstract	33	33	
<b>Warnings:</b>					
<b>Information:</b>					
<b>Total Files Size (in bytes):</b>			1145674		
<p>This Acknowledgement Receipt evidences receipt on the noted date by the USPTO of the indicated documents, characterized by the applicant, and including page counts, where applicable. It serves as evidence of receipt similar to a Post Card, as described in MPEP 503.</p> <p><b><u>New Applications Under 35 U.S.C. 111</u></b>  If a new application is being filed and the application includes the necessary components for a filing date (see 37 CFR 1.53(b)-(d) and MPEP 506), a Filing Receipt (37 CFR 1.54) will be issued in due course and the date shown on this Acknowledgement Receipt will establish the filing date of the application.</p> <p><b><u>National Stage of an International Application under 35 U.S.C. 371</u></b>  If a timely submission to enter the national stage of an international application is compliant with the conditions of 35 U.S.C. 371 and other applicable requirements a Form PCT/DO/EO/903 indicating acceptance of the application as a national stage submission under 35 U.S.C. 371 will be issued in addition to the Filing Receipt, in due course.</p> <p><b><u>New International Application Filed with the USPTO as a Receiving Office</u></b>  If a new international application is being filed and the international application includes the necessary components for an international filing date (see PCT Article 11 and MPEP 1810), a Notification of the International Application Number and of the International Filing Date (Form PCT/RO/105) will be issued in due course, subject to prescriptions concerning national security, and the date shown on this Acknowledgement Receipt will establish the international filing date of the application.</p>					



UNITED STATES PATENT AND TRADEMARK OFFICE

UNITED STATES DEPARTMENT OF COMMERCE
United States Patent and Trademark Office
Address: COMMISSIONER FOR PATENTS
P.O. Box 1450
Alexandria, Virginia 22313-1450
www.uspto.gov

Table with 7 columns: APPLICATION NUMBER, FILING or 371(c) DATE, GRP ART UNIT, FIL FEE REC'D, ATTY DOCKET NO, TOT CLAIMS, IND CLAIMS. Row 1: 13/675,665, 11/13/2012, 3738, 0.00, 109978.10101, 33, 5

CONFIRMATION NO. 1995

29880
FOX ROTHSCHILD LLP
PRINCETON PIKE CORPORATE CENTER
997 LENOX DRIVE
BLDG. #3
LAWRENCEVILLE, NJ 08648

FILING RECEIPT



Date Mailed: 12/12/2012

Receipt is acknowledged of this non-provisional patent application. The application will be taken up for examination in due course. Applicant will be notified as to the results of the examination. Any correspondence concerning the application must include the following identification information: the U.S. APPLICATION NUMBER, FILING DATE, NAME OF APPLICANT, and TITLE OF INVENTION. Fees transmitted by check or draft are subject to collection. Please verify the accuracy of the data presented on this receipt. If an error is noted on this Filing Receipt, please submit a written request for a Filing Receipt Correction. Please provide a copy of this Filing Receipt with the changes noted thereon. If you received a "Notice to File Missing Parts" for this application, please submit any corrections to this Filing Receipt with your reply to the Notice. When the USPTO processes the reply to the Notice, the USPTO will generate another Filing Receipt incorporating the requested corrections

Inventor(s)

None

Applicant(s)

Assignment For Published Patent Application

COLIBRI HEART VALVE LLC, Broomfield, CO

Power of Attorney: None

Domestic Priority data as claimed by applicant

This application is a CON of 10/887,688 07/10/2004 PAT 8308797 \*
which is a CIP of 10/037,266 01/04/2002 ABN

(\*)Data provided by applicant is not consistent with PTO records.

Foreign Applications for which priority is claimed (You may be eligible to benefit from the Patent Prosecution Highway program at the USPTO. Please see http://www.uspto.gov for more information.) - None.

Foreign application information must be provided in an Application Data Sheet in order to constitute a claim to foreign priority. See 37 CFR 1.55 and 1.76.

Permission to Access - A proper Authorization to Permit Access to Application by Participating Offices (PTO/SB/39 or its equivalent) has been received by the USPTO.

If Required, Foreign Filing License Granted: 12/05/2012

The country code and number of your priority application, to be used for filing abroad under the Paris Convention, is US 13/675,665

Projected Publication Date: To Be Determined - pending completion of Missing Parts

Non-Publication Request: No

**Early Publication Request:** No

**\*\* SMALL ENTITY \*\***

**Title**

PERCUTANEOUSLY IMPLANTABLE REPLACEMENT HEART VALVE DEVICE AND METHOD OF MAKING SAME

**Preliminary Class**

623

## **PROTECTING YOUR INVENTION OUTSIDE THE UNITED STATES**

Since the rights granted by a U.S. patent extend only throughout the territory of the United States and have no effect in a foreign country, an inventor who wishes patent protection in another country must apply for a patent in a specific country or in regional patent offices. Applicants may wish to consider the filing of an international application under the Patent Cooperation Treaty (PCT). An international (PCT) application generally has the same effect as a regular national patent application in each PCT-member country. The PCT process **simplifies** the filing of patent applications on the same invention in member countries, but **does not result** in a grant of "an international patent" and does not eliminate the need of applicants to file additional documents and fees in countries where patent protection is desired.

Almost every country has its own patent law, and a person desiring a patent in a particular country must make an application for patent in that country in accordance with its particular laws. Since the laws of many countries differ in various respects from the patent law of the United States, applicants are advised to seek guidance from specific foreign countries to ensure that patent rights are not lost prematurely.

Applicants also are advised that in the case of inventions made in the United States, the Director of the USPTO must issue a license before applicants can apply for a patent in a foreign country. The filing of a U.S. patent application serves as a request for a foreign filing license. The application's filing receipt contains further information and guidance as to the status of applicant's license for foreign filing.

Applicants may wish to consult the USPTO booklet, "General Information Concerning Patents" (specifically, the section entitled "Treaties and Foreign Patents") for more information on timeframes and deadlines for filing foreign patent applications. The guide is available either by contacting the USPTO Contact Center at 800-786-9199, or it can be viewed on the USPTO website at <http://www.uspto.gov/web/offices/pac/doc/general/index.html>.

For information on preventing theft of your intellectual property (patents, trademarks and copyrights), you may wish to consult the U.S. Government website, <http://www.stopfakes.gov>. Part of a Department of Commerce initiative, this website includes self-help "toolkits" giving innovators guidance on how to protect intellectual property in specific countries such as China, Korea and Mexico. For questions regarding patent enforcement issues, applicants may call the U.S. Government hotline at 1-866-999-HALT (1-866-999-4158).

**LICENSE FOR FOREIGN FILING UNDER**  
**Title 35, United States Code, Section 184**  
**Title 37, Code of Federal Regulations, 5.11 & 5.15**

**GRANTED**

The applicant has been granted a license under 35 U.S.C. 184, if the phrase "IF REQUIRED, FOREIGN FILING LICENSE GRANTED" followed by a date appears on this form. Such licenses are issued in all applications where the conditions for issuance of a license have been met, regardless of whether or not a license may be required as set forth in 37 CFR 5.15. The scope and limitations of this license are set forth in 37 CFR 5.15(a) unless an earlier license has been issued under 37 CFR 5.15(b). The license is subject to revocation upon written notification. The date indicated is the effective date of the license, unless an earlier license of similar scope has been granted under 37 CFR 5.13 or 5.14.

This license is to be retained by the licensee and may be used at any time on or after the effective date thereof unless it is revoked. This license is automatically transferred to any related applications(s) filed under 37 CFR 1.53(d). This license is not retroactive.

The grant of a license does not in any way lessen the responsibility of a licensee for the security of the subject matter as imposed by any Government contract or the provisions of existing laws relating to espionage and the national security or the export of technical data. Licensees should apprise themselves of current regulations especially with respect to certain countries, of other agencies, particularly the Office of Defense Trade Controls, Department of State (with respect to Arms, Munitions and Implements of War (22 CFR 121-128)); the Bureau of Industry and Security, Department of Commerce (15 CFR parts 730-774); the Office of Foreign Assets Control, Department of Treasury (31 CFR Parts 500+) and the Department of Energy.

**NOT GRANTED**

No license under 35 U.S.C. 184 has been granted at this time, if the phrase "IF REQUIRED, FOREIGN FILING LICENSE GRANTED" DOES NOT appear on this form. Applicant may still petition for a license under 37 CFR 5.12, if a license is desired before the expiration of 6 months from the filing date of the application. If 6 months has lapsed from the filing date of this application and the licensee has not received any indication of a secrecy order under 35 U.S.C. 181, the licensee may foreign file the application pursuant to 37 CFR 5.15(b).

---

***SelectUSA***

The United States represents the largest, most dynamic marketplace in the world and is an unparalleled location for business investment, innovation and commercialization of new technologies. The USA offers tremendous resources and advantages for those who invest and manufacture goods here. Through SelectUSA, our nation works to encourage, facilitate, and accelerate business investment. To learn more about why the USA is the best country in the world to develop technology, manufacture products, and grow your business, visit [SelectUSA.gov](http://SelectUSA.gov).

<b>PATENT APPLICATION FEE DETERMINATION RECORD</b>					Application or Docket Number 13/675,665					
Substitute for Form PTO-875										
<b>APPLICATION AS FILED - PART I</b>										
(Column 1)		(Column 2)			SMALL ENTITY		OR	OTHER THAN SMALL ENTITY		
FOR	NUMBER FILED	NUMBER EXTRA			RATE(\$)	FEE(\$)		RATE(\$)	FEE(\$)	
BASIC FEE <small>(37 CFR 1.16(a), (b), or (c))</small>	N/A	N/A			N/A	98		N/A		
SEARCH FEE <small>(37 CFR 1.16(k), (l), or (m))</small>	N/A	N/A			N/A	310		N/A		
EXAMINATION FEE <small>(37 CFR 1.16(o), (p), or (q))</small>	N/A	N/A			N/A	125		N/A		
TOTAL CLAIMS <small>(37 CFR 1.16(i))</small>	33	minus 20 =	*		x 31 =	403	OR			
INDEPENDENT CLAIMS <small>(37 CFR 1.16(h))</small>	5	minus 3 =	*		x 125 =	250				
APPLICATION SIZE FEE <small>(37 CFR 1.16(s))</small>	If the specification and drawings exceed 100 sheets of paper, the application size fee due is \$310 (\$155 for small entity) for each additional 50 sheets or fraction thereof. See 35 U.S.C. 41(a)(1)(G) and 37 CFR 1.16(s).					0.00				
MULTIPLE DEPENDENT CLAIM PRESENT <small>(37 CFR 1.16(j))</small>						0.00				
* If the difference in column 1 is less than zero, enter "0" in column 2.					TOTAL	1186		TOTAL		
<b>APPLICATION AS AMENDED - PART II</b>										
(Column 1)		(Column 2)		(Column 3)		SMALL ENTITY		OR	OTHER THAN SMALL ENTITY	
AMENDMENT A	CLAIMS REMAINING AFTER AMENDMENT	HIGHEST NUMBER PREVIOUSLY PAID FOR	PRESENT EXTRA		RATE(\$)	ADDITIONAL FEE(\$)		RATE(\$)	ADDITIONAL FEE(\$)	
	Total <small>(37 CFR 1.16(i))</small>	*	Minus	**	x	=	OR	x	=	
	Independent <small>(37 CFR 1.16(h))</small>	*	Minus	***	x	=	OR	x	=	
	Application Size Fee <small>(37 CFR 1.16(s))</small>							OR		
	FIRST PRESENTATION OF MULTIPLE DEPENDENT CLAIM <small>(37 CFR 1.16(j))</small>							OR		
					TOTAL ADD'L FEE		OR	TOTAL ADD'L FEE		
(Column 1)		(Column 2)		(Column 3)		SMALL ENTITY		OR	OTHER THAN SMALL ENTITY	
AMENDMENT B	CLAIMS REMAINING AFTER AMENDMENT	HIGHEST NUMBER PREVIOUSLY PAID FOR	PRESENT EXTRA		RATE(\$)	ADDITIONAL FEE(\$)		RATE(\$)	ADDITIONAL FEE(\$)	
	Total <small>(37 CFR 1.16(i))</small>	*	Minus	**	x	=	OR	x	=	
	Independent <small>(37 CFR 1.16(h))</small>	*	Minus	***	x	=	OR	x	=	
	Application Size Fee <small>(37 CFR 1.16(s))</small>							OR		
	FIRST PRESENTATION OF MULTIPLE DEPENDENT CLAIM <small>(37 CFR 1.16(j))</small>							OR		
					TOTAL ADD'L FEE		OR	TOTAL ADD'L FEE		
* If the entry in column 1 is less than the entry in column 2, write "0" in column 3.										
** If the "Highest Number Previously Paid For" IN THIS SPACE is less than 20, enter "20".										
*** If the "Highest Number Previously Paid For" IN THIS SPACE is less than 3, enter "3".										
The "Highest Number Previously Paid For" (Total or Independent) is the highest found in the appropriate box in column 1.										





UNITED STATES PATENT AND TRADEMARK OFFICE

UNITED STATES DEPARTMENT OF COMMERCE
United States Patent and Trademark Office
Address: COMMISSIONER FOR PATENTS
P.O. Box 1450
Alexandria, Virginia 22313-1450
www.uspto.gov

Table with 4 columns: APPLICATION NUMBER (13/675,665), FILING OR 371(C) DATE (11/13/2012), FIRST NAMED APPLICANT, ATTY. DOCKET NO./TITLE (109978.10101)

CONFIRMATION NO. 1995

FORMALITIES LETTER

29880
FOX ROTHSCHILD LLP
PRINCETON PIKE CORPORATE CENTER
997 LENOX DRIVE
BLDG. #3
LAWRENCEVILLE, NJ 08648



Date Mailed: 12/12/2012

NOTICE TO FILE MISSING PARTS OF NONPROVISIONAL APPLICATION

FILED UNDER 37 CFR 1.53(b)

Filing Date Granted

Items Required To Avoid Abandonment:

An application number and filing date have been accorded to this application. The item(s) indicated below, however, are missing. Applicant is given TWO MONTHS from the date of this Notice within which to file all required items below to avoid abandonment. Extensions of time may be obtained by filing a petition accompanied by the extension fee under the provisions of 37 CFR 1.136(a).

- The statutory basic filing fee is missing. Applicant must submit \$98 to complete the basic filing fee for a small entity.
A mailing address for each inventor has not been submitted. A new application data sheet (ADS) in compliance with 37 CFR 1.76 or inventor's oath or declaration in compliance with 37 CFR 1.63 identifying the mailing address and residence (if the inventor lives at a location which is different from where the inventor customarily receives mail) is required.
The application data sheet or inventor's oath or declaration does not identify each inventor by his or her legal name.

The application is informal since it does not comply with the regulations for the reason(s) indicated below.

The required item(s) identified below must be timely submitted to avoid abandonment:

- Replacement drawings in compliance with 37 CFR 1.84 and 37 CFR 1.121(d) are required. The drawings submitted are not acceptable because:
The drawings must be reasonably free from erasures and must be free from alterations, overwriting, interlineations, folds, and copy marks. See Figure(s) 9B and 9C.

Applicant is cautioned that correction of the above items may cause the specification and drawings page count to exceed 100 pages. If the specification and drawings exceed 100 pages, applicant will need to submit the required application size fee.

The applicant needs to satisfy supplemental fees problems indicated below.

The required item(s) identified below must be timely submitted to avoid abandonment:

- Additional claim fees of \$ **653** as a small entity, including any required multiple dependent claim fee, are required. Applicant must submit the additional claim fees or cancel the additional claims for which fees are due.
- A surcharge (for late submission of the basic filing fee, search fee, examination fee or inventor's oath or declaration) as set forth in 37 CFR 1.16(f) of \$ **65** for a small entity in compliance with 37 CFR 1.27, must be submitted.

**SUMMARY OF FEES DUE:**

Total fee(s) required within **TWO MONTHS** from the date of this Notice is \$ **1251** for a small entity

- \$ **98** Statutory basic filing fee.
- \$ **65** Surcharge.
- The application search fee has not been paid. Applicant must submit \$ **310** to complete the search fee.
- The application examination fee has not been paid. Applicant must submit \$ **125** to complete the examination fee for a small entity in compliance with 37 CFR 1.27.
- Total additional claim fee(s) for this application is \$ **653**
  - \$ **250** for **2** independent claims over 3.
  - \$ **403** for **13** total claims over 20.

**Items Required To Avoid Processing Delays:**

Applicant is notified that the above-identified application contains the deficiencies noted below. No period for reply is set forth in this notice for correction of these deficiencies. However, if a deficiency relates to the inventor's oath or declaration, the applicant must file an oath or declaration in compliance with 37 CFR 1.63, or a substitute statement in compliance with 37 CFR 1.64, executed by or with respect to each actual inventor no later than the expiration of the time period set in the "Notice of Allowability" to avoid abandonment. See 37 CFR 1.53(f).

- A properly executed inventor's oath or declaration has not been received for the following inventor(s):

All

Applicant may submit the inventor's oath or declaration at any time before the Notice of Allowance and Fee(s) Due, PTOL-85, is mailed.

Replies must be received in the USPTO within the set time period or must include a proper Certificate of Mailing or Transmission under 37 CFR 1.8 with a mailing or transmission date within the set time period. For more information and a suggested format, see Form PTO/SB/92 and MPEP 512.

Replies should be mailed to:

Mail Stop Missing Parts  
Commissioner for Patents  
P.O. Box 1450  
Alexandria VA 22313-1450

Registered users of EFS-Web may alternatively submit their reply to this notice via EFS-Web.  
<https://portal.uspto.gov/authenticate/AuthenticateUserLocalEPF.html>

For more information about EFS-Web please call the USPTO Electronic Business Center at **1-866-217-9197** or visit our website at <http://www.uspto.gov/ebc>.

If you are not using EFS-Web to submit your reply, you must include a copy of this notice.

/kung/

---

Office of Data Management, Application Assistance Unit (571) 272-4000, or (571) 272-4200, or 1-888-786-0101

IN THE UNITED STATES PATENT AND TRADEMARK OFFICE

In Re the Application of: ) Confirmation No.: 1995  
)  
PANIAGUA et al. ) Group Art Unit: 3738  
)  
Application No.: 13/675,665 ) Examiner: NOT YET ASSIGNED  
)  
Filed: November 13, 2012 )  
)  
Atty. File No.: 109978.10101 )  
)  
For: PERCUTANEOUSLY )  
IMPLANTABLE REPLACEMENT )  
HEART VALVE DEVICE AND )  
METHOD OF MAKING SAME )

**RESPONSE TO NOTICE OF  
MISSING PARTS**

*(Filed Electronically)*

<p><b>Certificate of EFS-Web Transmission</b> I hereby certify that this correspondence is being electronically transmitted to the U.S. Patent &amp; Trademark Office by the EFS-Web system on <u>11 July 2013</u>. Typed or printed name of person signing this certificate: <u>Carol Donahue</u> Signature: <u>/Carol Donahue/</u></p>
--

Commissioner for Patents  
P.O. Box 1450  
Alexandria Virginia 22313-1450

Dear Sir:

In response to the December 12, 2012 Notice to File Missing Parts, in connection with the above-identified application, small entity application fees, of which the claim fees are in accordance with a concurrently filed Preliminary Amendment, and a filing surcharge fee are submitted. A request for a five-month extension of time and requisite small entity fee are also submitted, bringing the responsive deadline to July 12, 2013. Please charge any over or underpayment to Deposit Account No. 50-1943.

Respectfully submitted,

FOX ROTHSCHILD LLP

/ Mark L. Yaskanin /

Mark L. Yaskanin

Registration No. 45,246

Customer No. 29880

Phone: (303) 446-3840

Facsimile: (303) 446-3841

Dated: 11 July 2013

ACTIVE 21723866

Under the Paperwork Reduction Act of 1995, no persons are required to respond to a collection of information unless it displays a valid OMB control number.

**DECLARATION (37 CFR 1.63) FOR UTILITY OR DESIGN APPLICATION USING AN APPLICATION DATA SHEET (37 CFR 1.76)**

<b>Title of Invention</b>	Percutaneously Implantable Replacement Heart Valve Device and Method of Making Same
---------------------------	---

As the below named inventor, I hereby declare that:

This declaration is directed to:  The attached application, or  United States application or PCT international application number 13/675,665 filed on November 13, 2012

The above-identified application was made or authorized to be made by me.

I believe that I am the original inventor or an original joint inventor of a claimed invention in the application.

I hereby acknowledge that any willful false statement made in this declaration is punishable under 18 U.S.C. 1001 by fine or imprisonment of not more than five (5) years, or both.

**WARNING:**

Petitioner/applicant is cautioned to avoid submitting personal information in documents filed in a patent application that may contribute to identity theft. Personal information such as social security numbers, bank account numbers, or credit card numbers (other than a check or credit card authorization form PTO-2038 submitted for payment purposes) is never required by the USPTO to support a petition or an application. If this type of personal information is included in documents submitted to the USPTO, petitioners/applicants should consider redacting such personal information from the documents before submitting them to the USPTO. Petitioner/applicant is advised that the record of a patent application is available to the public after publication of the application (unless a non-publication request in compliance with 37 CFR 1.213(a) is made in the application) or issuance of a patent. Furthermore, the record from an abandoned application may also be available to the public if the application is referenced in a published application or an issued patent (see 37 CFR 1.14). Checks and credit card authorization forms PTO-2038 submitted for payment purposes are not retained in the application file and therefore are not publicly available.

LEGAL NAME OF INVENTOR

Inventor: R. David FISH Date (Optional) : \_\_\_\_\_

Signature: *RDF*

Note: An application data sheet (PTO/SB/14 or equivalent), including naming the entire inventive entity, must accompany this form or must have been previously filed. Use an additional PTO/AIA/01 form for each additional inventor.

This collection of information is required by 35 U.S.C. 115 and 37 CFR 1.63. The information is required to obtain or retain a benefit by the public which is to file (and by the USPTO to process) an application. Confidentiality is governed by 35 U.S.C. 122 and 37 CFR 1.11 and 1.14. This collection is estimated to take 1 minute to complete, including gathering, preparing, and submitting the completed application form to the USPTO. Time will vary depending upon the individual case. Any comments on the amount of time you require to complete this form and/or suggestions for reducing this burden, should be sent to the Chief Information Officer, U.S. Patent and Trademark Office, U.S. Department of Commerce, P.O. Box 1450, Alexandria, VA 22313-1450. DO NOT SEND FEES OR COMPLETED FORMS TO THIS ADDRESS. SEND TO: Commissioner for Patents, P.O. Box 1450, Alexandria, VA 22313-1450.

*If you need assistance in completing the form, call 1-800-PTO-9199 and select option 2.*

Under the Paperwork Reduction Act of 1995, no persons are required to respond to a collection of information unless it displays a valid OMB control number.

**DECLARATION (37 CFR 1.63) FOR UTILITY OR DESIGN APPLICATION USING AN APPLICATION DATA SHEET (37 CFR 1.76)**

<b>Title of Invention</b>	Percutaneously Implantable Replacement Heart Valve Device and Method of Making Same
---------------------------	---

As the below named inventor, I hereby declare that:

This declaration is directed to:  The attached application, or  
 United States application or PCT international application number 13/675,665  
filed on November 13, 2012

The above-identified application was made or authorized to be made by me.

I believe that I am the original inventor or an original joint inventor of a claimed invention in the application.

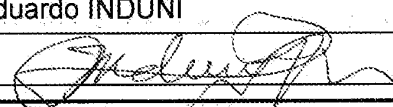
I hereby acknowledge that any willful false statement made in this declaration is punishable under 18 U.S.C. 1001 by fine or imprisonment of not more than five (5) years, or both.

**WARNING:**

Petitioner/applicant is cautioned to avoid submitting personal information in documents filed in a patent application that may contribute to identity theft. Personal information such as social security numbers, bank account numbers, or credit card numbers (other than a check or credit card authorization form PTO-2038 submitted for payment purposes) is never required by the USPTO to support a petition or an application. If this type of personal information is included in documents submitted to the USPTO, petitioners/applicants should consider redacting such personal information from the documents before submitting them to the USPTO. Petitioner/applicant is advised that the record of a patent application is available to the public after publication of the application (unless a non-publication request in compliance with 37 CFR 1.213(a) is made in the application) or issuance of a patent. Furthermore, the record from an abandoned application may also be available to the public if the application is referenced in a published application or an issued patent (see 37 CFR 1.14). Checks and credit card authorization forms PTO-2038 submitted for payment purposes are not retained in the application file and therefore are not publicly available.

LEGAL NAME OF INVENTOR

Inventor: Eduardo INDUNI Date (Optional): \_\_\_\_\_

Signature: 

Note: An application data sheet (PTO/SB/14 or equivalent), including naming the entire inventive entity, must accompany this form or must have been previously filed. Use an additional PTO/AIA/01 form for each additional inventor.

This collection of information is required by 35 U.S.C. 115 and 37 CFR 1.63. The information is required to obtain or retain a benefit by the public which is to file (and by the USPTO to process) an application. Confidentiality is governed by 35 U.S.C. 122 and 37 CFR 1.11 and 1.14. This collection is estimated to take 1 minute to complete, including gathering, preparing, and submitting the completed application form to the USPTO. Time will vary depending upon the individual case. Any comments on the amount of time you require to complete this form and/or suggestions for reducing this burden, should be sent to the Chief Information Officer, U.S. Patent and Trademark Office, U.S. Department of Commerce, P.O. Box 1450, Alexandria, VA 22313-1450. DO NOT SEND FEES OR COMPLETED FORMS TO THIS ADDRESS. **SEND TO: Commissioner for Patents, P.O. Box 1450, Alexandria, VA 22313-1450.**

If you need assistance in completing the form, call 1-800-PTO-9199 and select option 2.

## Privacy Act Statement

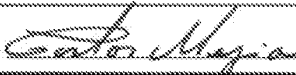
The **Privacy Act of 1974 (P.L. 93-579)** requires that you be given certain information in connection with your submission of the attached form related to a patent application or patent. Accordingly, pursuant to the requirements of the Act, please be advised that: (1) the general authority for the collection of this information is 35 U.S.C. 2(b)(2); (2) furnishing of the information solicited is voluntary; and (3) the principal purpose for which the information is used by the U.S. Patent and Trademark Office is to process and/or examine your submission related to a patent application or patent. If you do not furnish the requested information, the U.S. Patent and Trademark Office may not be able to process and/or examine your submission, which may result in termination of proceedings or abandonment of the application or expiration of the patent.

The information provided by you in this form will be subject to the following routine uses:

1. The information on this form will be treated confidentially to the extent allowed under the Freedom of Information Act (5 U.S.C. 552) and the Privacy Act (5 U.S.C. 552a). Records from this system of records may be disclosed to the Department of Justice to determine whether disclosure of these records is required by the Freedom of Information Act.
2. A record from this system of records may be disclosed, as a routine use, in the course of presenting evidence to a court, magistrate, or administrative tribunal, including disclosures to opposing counsel in the course of settlement negotiations.
3. A record in this system of records may be disclosed, as a routine use, to a Member of Congress submitting a request involving an individual, to whom the record pertains, when the individual has requested assistance from the Member with respect to the subject matter of the record.
4. A record in this system of records may be disclosed, as a routine use, to a contractor of the Agency having need for the information in order to perform a contract. Recipients of information shall be required to comply with the requirements of the Privacy Act of 1974, as amended, pursuant to 5 U.S.C. 552a(m).
5. A record related to an International Application filed under the Patent Cooperation Treaty in this system of records may be disclosed, as a routine use, to the International Bureau of the World Intellectual Property Organization, pursuant to the Patent Cooperation Treaty.
6. A record in this system of records may be disclosed, as a routine use, to another federal agency for purposes of National Security review (35 U.S.C. 181) and for review pursuant to the Atomic Energy Act (42 U.S.C. 218(c)).
7. A record from this system of records may be disclosed, as a routine use, to the Administrator, General Services, or his/her designee, during an inspection of records conducted by GSA as part of that agency's responsibility to recommend improvements in records management practices and programs, under authority of 44 U.S.C. 2904 and 2906. Such disclosure shall be made in accordance with the GSA regulations governing inspection of records for this purpose, and any other relevant (*i.e.*, GSA or Commerce) directive. Such disclosure shall not be used to make determinations about individuals.
8. A record from this system of records may be disclosed, as a routine use, to the public after either publication of the application pursuant to 35 U.S.C. 122(b) or issuance of a patent pursuant to 35 U.S.C. 151. Further, a record may be disclosed, subject to the limitations of 37 CFR 1.14, as a routine use, to the public if the record was filed in an application which became abandoned or in which the proceedings were terminated and which application is referenced by either a published application, an application open to public inspection or an issued patent.
9. A record from this system of records may be disclosed, as a routine use, to a Federal, State, or local law enforcement agency, if the USPTO becomes aware of a violation or potential violation of law or regulation.

Under the Paperwork Reduction Act of 1995, no persons are required to respond to a collection of information unless it displays a valid OMB control number.

**DECLARATION (37 CFR 1.63) FOR UTILITY OR DESIGN APPLICATION USING AN  
APPLICATION DATA SHEET (37 CFR 1.76)**

<b>Title of Invention</b>	<b>Percutaneously Implantable Replacement Heart Valve Device and Method of Making Same</b>
<p>As the below named inventor, I hereby declare that:</p> <p>This declaration is directed to: <input type="checkbox"/> The attached application, or  <input checked="" type="checkbox"/> United States application or PCT international application number <u>13/675,665</u>  filed on <u>November 13, 2012</u></p> <p>The above-identified application was made or authorized to be made by me.</p> <p>I believe that I am the original inventor or an original joint inventor of a claimed invention in the application.</p> <p>I hereby acknowledge that any willful false statement made in this declaration is punishable under 18 U.S.C. 1001 by fine or imprisonment of not more than five (5) years, or both.</p> <p style="text-align: center;"><b>WARNING:</b></p> <p>Petitioner/applicant is cautioned to avoid submitting personal information in documents filed in a patent application that may contribute to identity theft. Personal information such as social security numbers, bank account numbers, or credit card numbers (other than a check or credit card authorization form PTO-2038 submitted for payment purposes) is never required by the USPTO to support a petition or an application. If this type of personal information is included in documents submitted to the USPTO, petitioners/applicants should consider redacting such personal information from the documents before submitting them to the USPTO. Petitioner/applicant is advised that the record of a patent application is available to the public after publication of the application (unless a non-publication request in compliance with 37 CFR 1.213(a) is made in the application) or issuance of a patent. Furthermore, the record from an abandoned application may also be available to the public if the application is referenced in a published application or an issued patent (see 37 CFR 1.14). Checks and credit card authorization forms PTO-2038 submitted for payment purposes are not retained in the application file and therefore are not publicly available.</p>	
<b>LEGAL NAME OF INVENTOR</b>	
Inventor: <u>Carlos MEJIA</u> Date (Optional) : _____	
Signature: 	
<p>Note: An application data sheet (PTO/SB/14 or equivalent), including naming the entire inventive entity, must accompany this form or must have been previously filed. Use an additional PTO/AIA/01 form for each additional inventor.</p>	

This collection of information is required by 35 U.S.C. 115 and 37 CFR 1.63. The information is required to obtain or retain a benefit by the public which is to file (and by the USPTO to process) an application. Confidentiality is governed by 35 U.S.C. 122 and 37 CFR 1.11 and 1.14. This collection is estimated to take 1 minute to complete, including gathering, preparing, and submitting the completed application form to the USPTO. Time will vary depending upon the individual case. Any comments on the amount of time you require to complete this form and/or suggestions for reducing this burden, should be sent to the Chief Information Officer, U.S. Patent and Trademark Office, U.S. Department of Commerce, P.O. Box 1450, Alexandria, VA 22313-1450. DO NOT SEND FEES OR COMPLETED FORMS TO THIS ADDRESS. SEND TO: Commissioner for Patents, P.O. Box 1450, Alexandria, VA 22313-1450.

If you need assistance in completing the form, call 1-800-PTO-9199 and select option 2.



Under the Paperwork Reduction Act of 1995, no persons are required to respond to a collection of information unless it displays a valid OMB control number.

<b>PETITION FOR EXTENSION OF TIME UNDER 37 CFR 1.136(a)</b>	Docket Number (Optional) 109978.10101
---	--

Application Number 13/675,665	Filed 2012-11-13
----------------------------------	---------------------

For **Percutaneously Implantable Replacement Heart Valve Device and Method of Making Same**

Art Unit 3738	Examiner not assigned
------------------	--------------------------

This is a request under the provisions of 37 CFR 1.136(a) to extend the period for filing a reply in the above-identified application.

The requested extension and fee are as follows (check time period desired and enter the appropriate fee below):

	Fee	Small Entity Fee	Micro Entity Fee		
<input type="checkbox"/> One month (37 CFR 1.17(a)(1))	\$200	\$100	\$50	\$	
<input type="checkbox"/> Two months (37 CFR 1.17(a)(2))	\$600	\$300	\$150	\$	
<input type="checkbox"/> Three months (37 CFR 1.17(a)(3))	\$1,400	\$700	\$350	\$	
<input type="checkbox"/> Four months (37 CFR 1.17(a)(4))	\$2,200	\$1,100	\$550	\$	
<input checked="" type="checkbox"/> Five months (37 CFR 1.17(a)(5))	\$3,000	\$1,500	\$750	\$	1500

- Applicant asserts small entity status. See 37 CFR 1.27.
- Applicant certifies micro entity status. See 37 CFR 1.29.  
Form PTO/SB/15A or B or equivalent must either be enclosed or have been submitted previously.
- A check in the amount of the fee is enclosed.
- Payment by credit card. Form PTO-2038 is attached.
- The Director has already been authorized to charge fees in this application to a Deposit Account.
- The Director is hereby authorized to charge any fees which may be required, or credit any overpayment, to  
Deposit Account Number 50-1943.
- Payment made via EFS-Web.

**WARNING: Information on this form may become public. Credit card information should not be included on this form. Provide credit card information and authorization on PTO-2038.**

I am the

- applicant.
- attorney or agent of record. Registration number 45246.
- attorney or agent acting under 37 CFR 1.34. Registration number \_\_\_\_\_.

<u>/ Mark L. Yaskanin /</u>	<u>11 July 2013</u>
Signature	Date
<u>Mark L. Yaskanin</u>	<u>303.446.3840</u>
Typed or printed name	Telephone Number

**NOTE:** This form must be signed in accordance with 37 CFR 1.33. See 37 CFR 1.4 for signature requirements and certifications. Submit multiple forms if more than one signature is required, see below\*.

<input type="checkbox"/> * Total of _____ forms are submitted.
--

This collection of information is required by 37 CFR 1.136(a). The information is required to obtain or retain a benefit by the public, which is to file (and by the USPTO to process) an application. Confidentiality is governed by 35 U.S.C. 122 and 37 CFR 1.11 and 1.14. This collection is estimated to take 6 minutes to complete, including gathering, preparing, and submitting the completed application form to the USPTO. Time will vary depending upon the individual case. Any comments on the amount of time you require to complete this form and/or suggestions for reducing this burden should be sent to the Chief Information Officer, U.S. Patent and Trademark Office, U.S. Department of Commerce, P.O. Box 1450, Alexandria, VA 22313-1450. DO NOT SEND FEES OR COMPLETED FORMS TO THIS ADDRESS. SEND TO: Mail Stop PCT, Commissioner for Patents, P.O. Box 1450, Alexandria, VA 22313-1450.

## Privacy Act Statement

The **Privacy Act of 1974 (P.L. 93-579)** requires that you be given certain information in connection with your submission of the attached form related to a patent application or patent. Accordingly, pursuant to the requirements of the Act, please be advised that: (1) the general authority for the collection of this information is 35 U.S.C. 2(b)(2); (2) furnishing of the information solicited is voluntary; and (3) the principal purpose for which the information is used by the U.S. Patent and Trademark Office is to process and/or examine your submission related to a patent application or patent. If you do not furnish the requested information, the U.S. Patent and Trademark Office may not be able to process and/or examine your submission, which may result in termination of proceedings or abandonment of the application or expiration of the patent.

The information provided by you in this form will be subject to the following routine uses:

1. The information on this form will be treated confidentially to the extent allowed under the Freedom of Information Act (5 U.S.C. 552) and the Privacy Act (5 U.S.C. 552a). Records from this system of records may be disclosed to the Department of Justice to determine whether disclosure of these records is required by the Freedom of Information Act.
2. A record from this system of records may be disclosed, as a routine use, in the course of presenting evidence to a court, magistrate, or administrative tribunal, including disclosures to opposing counsel in the course of settlement negotiations.
3. A record in this system of records may be disclosed, as a routine use, to a Member of Congress submitting a request involving an individual, to whom the record pertains, when the individual has requested assistance from the Member with respect to the subject matter of the record.
4. A record in this system of records may be disclosed, as a routine use, to a contractor of the Agency having need for the information in order to perform a contract. Recipients of information shall be required to comply with the requirements of the Privacy Act of 1974, as amended, pursuant to 5 U.S.C. 552a(m).
5. A record related to an International Application filed under the Patent Cooperation Treaty in this system of records may be disclosed, as a routine use, to the International Bureau of the World Intellectual Property Organization, pursuant to the Patent Cooperation Treaty.
6. A record in this system of records may be disclosed, as a routine use, to another federal agency for purposes of National Security review (35 U.S.C. 181) and for review pursuant to the Atomic Energy Act (42 U.S.C. 218(c)).
7. A record from this system of records may be disclosed, as a routine use, to the Administrator, General Services, or his/her designee, during an inspection of records conducted by GSA as part of that agency's responsibility to recommend improvements in records management practices and programs, under authority of 44 U.S.C. 2904 and 2906. Such disclosure shall be made in accordance with the GSA regulations governing inspection of records for this purpose, and any other relevant (*i.e.*, GSA or Commerce) directive. Such disclosure shall not be used to make determinations about individuals.
8. A record from this system of records may be disclosed, as a routine use, to the public after either publication of the application pursuant to 35 U.S.C. 122(b) or issuance of a patent pursuant to 35 U.S.C. 151. Further, a record may be disclosed, subject to the limitations of 37 CFR 1.14, as a routine use, to the public if the record was filed in an application which became abandoned or in which the proceedings were terminated and which application is referenced by either a published application, an application open to public inspection or an issued patent.
9. A record from this system of records may be disclosed, as a routine use, to a Federal, State, or local law enforcement agency, if the USPTO becomes aware of a violation or potential violation of law or regulation.

IN THE UNITED STATES PATENT AND TRADEMARK OFFICE

In Re the Application of: ) Confirmation No.: 1995  
)  
PANIAGUA et al. ) Group Art Unit: 3738  
)  
Application No.: 13/675,665 ) Examiner: NOT YET ASSIGNED  
)  
Filed: November 13, 2012 )  
)  
Atty. File No.: 109978.10101 )  
)  
For: PERCUTANEOUSLY )  
IMPLANTABLE REPLACEMENT )  
HEART VALVE DEVICE AND )  
METHOD OF MAKING SAME )

**PRELIMINARY AMENDMENT**

*(Filed Electronically)*

<p><b>Certificate of EFS-Web Transmission</b> I hereby certify that this correspondence is being electronically transmitted to the U.S. Patent &amp; Trademark Office by the EFS-Web system on <u>11 July 2013</u>. Typed or printed name of person signing this certificate: <u>Carol Donahue</u> Signature: <u>/ Carol Donahue /</u></p>
--

Commissioner for Patents  
P.O. Box 1450  
Alexandria Virginia 22313-1450

Dear Sir:

Prior to the initial review of the above-identified patent application by the Examiner, please enter the following Preliminary Amendment. Although Applicants do not believe that any fees are due based upon the filing of this Preliminary Amendment, please charge any underpayment or debit any overpayment to Deposit Account No. 50-1943.

Please amend the above-entitled patent application as follows:

**Amendments To The Claims** begin on page 2 of this paper.

**Remarks** begin on page 6 of this paper.

ACTIVE 21358648

**AMENDMENTS TO THE CLAIMS**

This listing of claims will replace all prior versions, and listings, of claims in the application:

**Listing of Claims:**

1.     **(Original)**     A percutaneously implantable replacement heart valve device comprising an expandable stent member and a flexible, compressible artificial valve made of biocompatible tissue material and disposed within the inner cavity of said stent member affixed at one or more points on said artificial valve's outer surface to said stent member, said artificial valve having cusps or leaflets formed by folding of a sheet of said biocompatible tissue material without affixing of separate cusps or leaflets or cutting slits into said material to form said cusps or leaflets.

2.     **(Original)**     The percutaneously implantable replacement heart valve device of claim 1, wherein said expandable stent member is made of a metal or alloy of metals selected from the group consisting of nickel-titanium alloy, titanium and stainless steel.

3.     **(Original)**     The percutaneously implantable replacement heart valve device of claim 1, wherein said biocompatible tissue material of said artificial valve comprises mammal pericardium tissue.

4.     **(Original)**     The percutaneously implantable replacement heart valve device of claim 1, wherein said biocompatible tissue material of said artificial valve comprises porcine pericardium tissue.

5. **(Original)** The percutaneously implantable replacement heart valve device of claim 1, wherein said biocompatible tissue material of said artificial valve is obtained from a juvenile animal pericardium.

6. **(Original)** The percutaneously implantable replacement heart valve device of claim 1, wherein said biocompatible tissue material of said artificial valve comprises autologous tissue obtained from the patient into whom said replacement heart valve device will be implanted.

7. **(Original)** The percutaneously implantable heart valve device of claim 1, wherein said biocompatible tissue material of said artificial valve comprises a synthetic biocompatible material.

8. **(Original)** The percutaneously implantable heart valve device of claim 7, wherein said synthetic biocompatible material is selected from the group consisting of polytetrafluoroethylene, polyester, metal, metal alloy including combinations thereof.

9. **(Original)** The percutaneously implantable heart valve device of claim 1, wherein said stent member is self-expanding when implanted.

10. **(Original)** The percutaneously implantable heart valve device of claim 1, wherein said stent member is balloon catheter expandable when implanted.

11.-26.       **(Cancelled)**

27.       **(Original)**     A percutaneously implantable replacement heart valve device comprising an expandable stent member and a flexible, compressible artificial valve made of biocompatible tissue material and disposed within the inner cavity of said stent member affixed at one or more points on said artificial valve's outer surface to said stent member, said artificial valve comprising a leaflet or cusp portion formed by folding of a first sheet portion of said biocompatible tissue material without affixing of separate cusps or leaflets or cutting slits into said sheet to form said cusps or leaflets, and an outer tubular cuff structure formed by folding a second sheet portion of biocompatible tissue material, said first and second sheet portions being affixed together.

28.       **(Original)**     The device of claim 27, wherein said first sheet portion and said second sheet portions are affixed together by suturing.

29.       **(Original)**     The device of claim 28, wherein said suturing is in the form of double continuous sutures.

30.-32.       **(Cancelled)**

33. **(Original)** A percutaneously implantable replacement heart valve device comprising an expandable stent member and a flexible, compressible artificial valve made of biocompatible tissue material and disposed within the inner cavity of said stent member affixed at one or more points on said artificial valve's outer surface to said stent member, said artificial valve comprising a leaflet or cusp portion formed by folding of a first sheet portion of said biocompatible tissue material without affixing of separate cusps or leaflets or cutting slits into said sheet to form said cusps or leaflets.

**REMARKS**

Applicants request that this Preliminary Amendment be entered and the claims presented herein be examined in this application. Claims 11-26 and 30-32 have been cancelled and no new matter has been added.

In the event that the Examiner has any questions regarding this Preliminary Amendment, the Examiner is invited to contact the below-named attorney at (303) 446-3840.

Respectfully submitted,

FOX ROTHSCHILD LLP

/ Mark L. Yaskanin /

Mark L. Yaskanin

Registration No. 45,246

Customer No. 29880

Phone: (303) 446-3840

Facsimile: (303) 446-3841

Dated: 11 July 2013



Under the Paperwork Reduction Act of 1995, no persons are required to respond to a collection of information unless it displays a valid OMB control number.

**DECLARATION (37 CFR 1.63) FOR UTILITY OR DESIGN APPLICATION USING AN APPLICATION DATA SHEET (37 CFR 1.76)**

Title of Invention	Percutaneously Implantable Replacement Heart Valve Device and Method of Making Same
--------------------	---

As the below named inventor, I hereby declare that:

This declaration is directed to  The attached application, or  United States application or PCT international application number 13/675,665 filed on November 13, 2012

The above-identified application was made or authorized to be made by me

I believe that I am the original inventor or an original joint inventor of a claimed invention in the application.

I hereby acknowledge that any willful false statement made in this declaration is punishable under 18 U.S.C. 1001 by fine or imprisonment of not more than five (5) years, or both.

**WARNING:**

Petitioner/applicant is cautioned to avoid submitting personal information in documents filed in a patent application that may contribute to identify theft. Personal information such as social security numbers, bank account numbers, or credit card numbers (other than a check or credit card authorization form PTO-2038 submitted for payment purposes) is never required by the USPTO to support a petition or an application. If this type of personal information is included in documents submitted to the USPTO, petitioners/applicants should consider redacting such personal information from the documents before submitting them to the USPTO. Petitioner/applicant is advised that the record of a patent application is available to the public after publication of the application (unless a non-publication request in compliance with 37 CFR 1.213(a) is made in the application) or issuance of a patent. Furthermore, the record from an abandoned application may also be available to the public if the application is referenced in a published application or an issued patent (see 37 CFR 1.14). Checks and credit card authorization forms PTO-2038 submitted for payment purposes are not retained in the application file and therefore are not publicly available.

**LEGAL NAME OF INVENTOR**

Inventor David PANIAGUA Date (Optional) \_\_\_\_\_  
Signature: 

Note: An application data sheet (PTO/SB/14 or equivalent), including naming the entire inventive entity, must accompany this form or must have been previously filed. Use an additional PTO/AIA/D1 form for each additional inventor.

This collection of information is required by 35 U.S.C. 115 and 37 CFR 1.63. The information is required to obtain or retain a benefit by the public which is to be (and by the USPTO to process) an application. Confidentiality is governed by 35 U.S.C. 122 and 37 CFR 1.11 and 1.14. This collection is estimated to take 1 minute to complete, including gathering, preparing, and submitting the completed application form to the USPTO. Time will vary depending upon the individual case. Any comments on the amount of time you require to complete this form and/or suggestions for reducing this burden, should be sent to the Chief Information Officer, U.S. Patent and Trademark Office, U.S. Department of Commerce, P.O. Box 1450, Alexandria, VA 22313-1450. DO NOT SEND FEES OR COMPLETED FORMS TO THIS ADDRESS. SEND TO: Commissioner for Patents, P.O. Box 1450, Alexandria, VA 22313-1450.

If you need assistance in completing the form, call 1-800-PTO-9199 and select option 2.

**DECLARATION (37 CFR 1.63) FOR UTILITY OR DESIGN APPLICATION USING AN APPLICATION DATA SHEET (37 CFR 1.76)**

Title of Invention	Percutaneously Implantable Replacement Heart Valve Device and Method of Making Same
--------------------	---

As the below named inventor, I hereby declare that:

This declaration is directed to:  The attached application, or  United States application or PCT international application number 13/675,665 filed on November 13, 2012

The above-identified application was made or authorized to be made by me.

I believe that I am the original inventor or an original joint inventor of a claimed invention in the application.

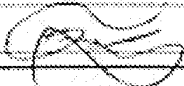
I hereby acknowledge that any willful false statement made in this declaration is punishable under 18 U.S.C. 1001 by fine or imprisonment of not more than five (5) years, or both.

**WARNING:**

Petitioner/applicant is cautioned to avoid submitting personal information in documents filed in a patent application that may contribute to identity theft. Personal information such as social security numbers, bank account numbers, or credit card numbers (other than a check or credit card authorization form PTO-2008 submitted for payment purposes) is never required by the USPTO to support a petition or an application. If this type of personal information is included in documents submitted to the USPTO, petitioners/applicants should consider redacting such personal information from the documents before submitting them to the USPTO. Petitioner/applicant is advised that the record of a patent application is available to the public after publication of the application (unless a non-publication request in compliance with 37 CFR 1.213(a) is made in the application) or issuance of a patent. Furthermore, the record from an abandoned application may also be available to the public if the application is referenced in a published application or an issued patent (see 37 CFR 1.14). Checks and credit card authorization forms PTO-2008 submitted for payment purposes are not retained in the application file and therefore are not publicly available.

LEGAL NAME OF INVENTOR

Inventor Francisco LOPEZ-JIMENEZ Date (Optional) 7/8/13

Signature 

Note: An application data sheet (PTO/SB/14 or equivalent), including naming the entire inventive entity, must accompany this form or must have been previously filed. Use an additional PTO/AIA/G1 form for each additional inventor.

This collection of information is required by 35 U.S.C. 115 and 37 CFR 1.63. The information is required to obtain or retain a benefit by the public which is to be used by the USPTO to process an application. Confidentiality is governed by 35 U.S.C. 122 and 37 CFR 1.11 and 1.14. This collection is estimated to take 1 minute to complete, including gathering, preparing, and submitting the completed application form to the USPTO. Time will vary depending upon the individual case. Any comments on the amount of time you require to complete this form and/or suggestions for reducing this burden, should be sent to the Chief Information Officer, U.S. Patent and Trademark Office, U.S. Department of Commerce, P.O. Box 1450, Alexandria, VA 22313-1450. DO NOT SEND FEES OR COMPLETED FORMS TO THIS ADDRESS. SEND TO: Commissioner for Patents, P.O. Box 1458, Alexandria, VA 22313-1458.

If you need assistance in completing the form, call 1-800-P-TO-9100 and select option 2.

Under the Paperwork Reduction Act of 1995, no persons are required to respond to a collection of information unless it contains a valid OMB control number.

<b>Application Data Sheet 37 CFR 1.76</b>	Attorney Docket Number	109978.10101
	Application Number	13/675,665
Title of Invention	Percutaneously Implantable Replacement Heart Valve Device and Method of Making Same	
The application data sheet is part of the provisional or nonprovisional application for which it is being submitted. The following form contains the bibliographic data arranged in a format specified by the United States Patent and Trademark Office as outlined in 37 CFR 1.76. This document may be completed electronically and submitted to the Office in electronic format using the Electronic Filing System (EFS) or the document may be printed and included in a paper filed application.		

**Secrecy Order 37 CFR 5.2**

Portions or all of the application associated with this Application Data Sheet may fall under a Secrecy Order pursuant to 37 CFR 5.2 (Paper filers only. Applications that fall under Secrecy Order may not be filed electronically.)

**Inventor Information:**

<b>Inventor 1</b>					<input type="button" value="Remove"/>
<b>Legal Name</b>					
<b>Prefix</b>	<b>Given Name</b>	<b>Middle Name</b>	<b>Family Name</b>	<b>Suffix</b>	
	David		PANIAGUA		
<b>Residence Information (Select One)</b> <input checked="" type="radio"/> US Residency <input type="radio"/> Non US Residency <input type="radio"/> Active US Military Service					
<b>City</b>	Houston	<b>State/Province</b>	TX	<b>Country of Residence</b>	US
<b>Mailing Address of Inventor:</b>					
<b>Address 1</b>	3813 Drummond Street				
<b>Address 2</b>					
<b>City</b>	Houston	<b>State/Province</b>	TX		
<b>Postal Code</b>	77025	<b>Country</b>	US		
<b>Inventor 2</b>					<input type="button" value="Remove"/>
<b>Legal Name</b>					
<b>Prefix</b>	<b>Given Name</b>	<b>Middle Name</b>	<b>Family Name</b>	<b>Suffix</b>	
	R.	David	FISH		
<b>Residence Information (Select One)</b> <input checked="" type="radio"/> US Residency <input type="radio"/> Non US Residency <input type="radio"/> Active US Military Service					
<b>City</b>	Houston	<b>State/Province</b>	TX	<b>Country of Residence</b>	US
<b>Mailing Address of Inventor:</b>					
<b>Address 1</b>	6349 Vanderbilt Street				
<b>Address 2</b>					
<b>City</b>	Houston	<b>State/Province</b>	TX		
<b>Postal Code</b>	77005	<b>Country</b>	US		
<b>Inventor 3</b>					<input type="button" value="Remove"/>
<b>Legal Name</b>					
<b>Prefix</b>	<b>Given Name</b>	<b>Middle Name</b>	<b>Family Name</b>	<b>Suffix</b>	
	Eduardo		INDUNI		
<b>Residence Information (Select One)</b> <input type="radio"/> US Residency <input checked="" type="radio"/> Non US Residency <input type="radio"/> Active US Military Service					

Under the Paperwork Reduction Act of 1995, no persons are required to respond to a collection of information unless it contains a valid OMB control number.

<b>Application Data Sheet 37 CFR 1.76</b>		Attorney Docket Number	109978.10101	
		Application Number	13/675,665	
Title of Invention	Percutaneously Implantable Replacement Heart Valve Device and Method of Making Same			
City	Alajuela	Country of Residence	CR	
<b>Mailing Address of Inventor:</b>				
Address 1	Resi Alajuela H7			
Address 2				
City	Alajuela	State/Province		
Postal Code	906 4050	Country	CR	
Inventor 4				<input type="button" value="Remove"/>
Legal Name				
Prefix	Given Name	Middle Name	Family Name	Suffix
	Carlos		MEIJA	
Residence Information (Select One) <input checked="" type="radio"/> US Residency <input type="radio"/> Non US Residency <input type="radio"/> Active US Military Service				
City	Houston	State/Province	TX	Country of Residence
				US
<b>Mailing Address of Inventor:</b>				
Address 1	3503 Deal Street			
Address 2				
City	Houston	State/Province	TX	
Postal Code	77025	Country	US	
Inventor 5				<input type="button" value="Remove"/>
Legal Name				
Prefix	Given Name	Middle Name	Family Name	Suffix
	Fransisco		LOPEZ-JIMENEZ	
Residence Information (Select One) <input checked="" type="radio"/> US Residency <input type="radio"/> Non US Residency <input type="radio"/> Active US Military Service				
City	Rochester	State/Province	MN	Country of Residence
				US
<b>Mailing Address of Inventor:</b>				
Address 1	200 First Street			
Address 2				
City	Rochester	State/Province	MN	
Postal Code	55901	Country	US	
All Inventors Must Be Listed - Additional Inventor Information blocks may be generated within this form by selecting the <b>Add</b> button.				<input type="button" value="Add"/>

**Correspondence Information:**

Enter either Customer Number or complete the Correspondence Information section below.  
For further information see 37 CFR 1.33(a).

Under the Paperwork Reduction Act of 1995, no persons are required to respond to a collection of information unless it contains a valid OMB control number.

<b>Application Data Sheet 37 CFR 1.76</b>		Attorney Docket Number	109978.10101
		Application Number	13/675,665
Title of Invention	Percutaneously Implantable Replacement Heart Valve Device and Method of Making Same		

 An Address is being provided for the correspondence information of this application.

Customer Number	29880		
Email Address		<input type="button" value="Add Email"/>	<input type="button" value="Remove Email"/>

**Application Information:**

Title of the Invention	Percutaneously Implantable Replacement Heart Valve Device and Method of Making Same		
Attorney Docket Number	109978.10101	Small Entity Status Claimed	<input checked="" type="checkbox"/>
Application Type	Nonprovisional		
Subject Matter	Utility		
Total Number of Drawing Sheets (if any)	12	Suggested Figure for Publication (if any)	

**Publication Information:**
 Request Early Publication (Fee required at time of Request 37 CFR 1.219)

 **Request Not to Publish.** I hereby request that the attached application not be published under 35 U.S.C. 122(b) and certify that the invention disclosed in the attached application **has not and will not be** the subject of an application filed in another country, or under a multilateral international agreement, that requires publication at eighteen months after filing.
**Representative Information:**

Representative information should be provided for all practitioners having a power of attorney in the application. Providing this information in the Application Data Sheet does not constitute a power of attorney in the application (see 37 CFR 1.32). Either enter Customer Number or complete the Representative Name section below. If both sections are completed the customer number will be used for the Representative Information during processing.

Please Select One:	<input checked="" type="radio"/> Customer Number	<input type="radio"/> US Patent Practitioner	<input type="radio"/> Limited Recognition (37 CFR 11.9)
Customer Number	29880		

**Domestic Benefit/National Stage Information:**

This section allows for the applicant to either claim benefit under 35 U.S.C. 119(e), 120, 121, or 365(c) or indicate National Stage entry from a PCT application. Providing this information in the application data sheet constitutes the specific reference required by 35 U.S.C. 119(e) or 120, and 37 CFR 1.78.

Prior Application Status	Patented -Pending-		<input type="button" value="Remove"/>		
Application Number	Continuity Type	Prior Application Number	Filing Date (YYYY-MM-DD)	Patent Number	Issue Date (YYYY-MM-DD)
13675665	Continuation of	10887688	2004-07-10	8308797	2012-11-13
Prior Application Status	Abandoned		<input type="button" value="Remove"/>		
Application Number	Continuity Type	Prior Application Number	Filing Date (YYYY-MM-DD)		
10887668	Continuation in part of	10037266	2002-01-04		

<b>Application Data Sheet 37 CFR 1.76</b>	Attorney Docket Number	109978.10101
	Application Number	13/675,665
Title of Invention	Percutaneously Implantable Replacement Heart Valve Device and Method of Making Same	

Additional Domestic Benefit/National Stage Data may be generated within this form by selecting the **Add** button.

### Foreign Priority Information:

This section allows for the applicant to claim priority to a foreign application. Providing this information in the application data sheet constitutes the claim for priority as required by 35 U.S.C. 119(b) and 37 CFR 1.55(d). When priority is claimed to a foreign application that is eligible for retrieval under the priority document exchange program (PDX) the information will be used by the Office to automatically attempt retrieval pursuant to 37 CFR 1.55(h)(1) and (2). Under the PDX program, applicant bears the ultimate responsibility for ensuring that a copy of the foreign application is received by the Office from the participating foreign intellectual property office, or a certified copy of the foreign priority application is filed, within the time period specified in 37 CFR 1.55(g)(1).

Application Number	Country	Filing Date (YYYY-MM-DD)	Access Code <sup>1</sup> if applicable

Additional Foreign Priority Data may be generated within this form by selecting the **Add** button.

### Statement under 37 CFR 1.55 or 1.78 for AIA (First Inventor to File) Transition Applications

- This application (1) claims priority to or the benefit of an application filed before March 16, 2013 and (2) also contains, or contained at any time, a claim to a claimed invention that has an effective filing date on or after March 16, 2013.
- NOTE: By providing this statement under 37 CFR 1.55 or 1.78, this application, with a filing date on or after March 16, 2013, will be examined under the first inventor to file provisions of the AIA.

### Authorization to Permit Access:

<input checked="" type="checkbox"/> Authorization to Permit Access to the Instant Application by the Participating Offices
--

Under the Paperwork Reduction Act of 1995, no persons are required to respond to a collection of information unless it contains a valid OMB control number.

<b>Application Data Sheet 37 CFR 1.76</b>	Attorney Docket Number	109978.10101
	Application Number	13/675,665
Title of Invention	Percutaneously Implantable Replacement Heart Valve Device and Method of Making Same	

If checked, the undersigned hereby grants the USPTO authority to provide the European Patent Office (EPO), the Japan Patent Office (JPO), the Korean Intellectual Property Office (KIPO), the World Intellectual Property Office (WIPO), and any other intellectual property offices in which a foreign application claiming priority to the instant patent application is filed access to the instant patent application. See 37 CFR 1.14(c) and (h). This box should not be checked if the applicant does not wish the EPO, JPO, KIPO, WIPO, or other intellectual property office in which a foreign application claiming priority to the instant patent application is filed to have access to the instant patent application.

In accordance with 37 CFR 1.14(h)(3), access will be provided to a copy of the instant patent application with respect to: 1) the instant patent application-as-filed; 2) any foreign application to which the instant patent application claims priority under 35 U.S.C. 119(a)-(d) if a copy of the foreign application that satisfies the certified copy requirement of 37 CFR 1.55 has been filed in the instant patent application; and 3) any U.S. application-as-filed from which benefit is sought in the instant patent application.

In accordance with 37 CFR 1.14(c), access may be provided to information concerning the date of filing this Authorization.

## Applicant Information:

Providing assignment information in this section does not substitute for compliance with any requirement of part 3 of Title 37 of CFR to have an assignment recorded by the Office.

### Applicant 1

If the applicant is the inventor (or the remaining joint inventor or inventors under 37 CFR 1.45), this section should not be completed. The information to be provided in this section is the name and address of the legal representative who is the applicant under 37 CFR 1.43; or the name and address of the assignee, person to whom the inventor is under an obligation to assign the invention, or person who otherwise shows sufficient proprietary interest in the matter who is the applicant under 37 CFR 1.46. If the applicant is an applicant under 37 CFR 1.46 (assignee, person to whom the inventor is obligated to assign, or person who otherwise shows sufficient proprietary interest) together with one or more joint inventors, then the joint inventor or inventors who are also the applicant should be identified in this section.

Assignee
  Legal Representative under 35 U.S.C. 117
  Joint Inventor

Person to whom the inventor is obligated to assign.
  Person who shows sufficient proprietary interest

If applicant is the legal representative, indicate the authority to file the patent application, the inventor is:

Name of the Deceased or Legally Incapacitated Inventor :

If the Applicant is an Organization check here.

Organization Name COLIBRI HEART VALVE LLC

### Mailing Address Information For Applicant:

Address 1	2150 W. 6th Ave., Unit M		
Address 2			
City	Broomfield	State/Province	CO
Country	US	Postal Code	80020
Phone Number		Fax Number	

Under the Paperwork Reduction Act of 1995, no persons are required to respond to a collection of information unless it contains a valid OMB control number.

<b>Application Data Sheet 37 CFR 1.76</b>		Attorney Docket Number	109978.10101
		Application Number	13/675,665
Title of Invention	Percutaneously Implantable Replacement Heart Valve Device and Method of Making Same		
Email Address			
Additional Applicant Data may be generated within this form by selecting the Add button.			

### Non-Applicant Assignee Information:

Providing assignment information in this section does not substitute for compliance with any requirement of part 3 of Title 37 of CFR to have an assignment recorded by the Office.				
<b>Assignee 1</b>				
Complete this section only if non-applicant assignee information is desired to be included on the patent application publication in accordance with 37 CFR 1.215(b). Do not include in this section an applicant under 37 CFR 1.46 (assignee, person to whom the inventor is obligated to assign, or person who otherwise shows sufficient proprietary interest), as the patent application publication will include the name of the applicant(s).				
If the Assignee is an Organization check here. <input type="checkbox"/>				
Prefix	Given Name	Middle Name	Family Name	Suffix
<b>Mailing Address Information For Non-Applicant Assignee:</b>				
Address 1				
Address 2				
City		State/Province		
Country <sup>i</sup>		Postal Code		
Phone Number		Fax Number		
Email Address				
Additional Assignee Data may be generated within this form by selecting the Add button.				

### Signature:

NOTE: This form must be signed in accordance with 37 CFR 1.33. See 37 CFR 1.4 for signature requirements and certifications.					
Signature	/ Mark L. Yaskanin /		Date (YYYY-MM-DD)	2013-07-11	
First Name	Mrak	Last Name	Yaskanin	Registration Number	45246
Additional Signature may be generated within this form by selecting the Add button.					



Under the Paperwork Reduction Act of 1995, no persons are required to respond to a collection of information unless it contains a valid OMB control number.

<b>Application Data Sheet 37 CFR 1.76</b>		Attorney Docket Number	109978.10101
		Application Number	<u>13/675,665</u>
Title of Invention	Percutaneously Implantable Replacement Heart Valve Device and Method of Making Same		

This collection of information is required by 37 CFR 1.76. The information is required to obtain or retain a benefit by the public which is to file (and by the USPTO to process) an application. Confidentiality is governed by 35 U.S.C. 122 and 37 CFR 1.14. This collection is estimated to take 23 minutes to complete, including gathering, preparing, and submitting the completed application data sheet form to the USPTO. Time will vary depending upon the individual case. Any comments on the amount of time you require to complete this form and/or suggestions for reducing this burden, should be sent to the Chief Information Officer, U.S. Patent and Trademark Office, U.S. Department of Commerce, P.O. Box 1450, Alexandria, VA 22313-1450. DO NOT SEND FEES OR COMPLETED FORMS TO THIS ADDRESS. **SEND TO: Commissioner for Patents, P.O. Box 1450, Alexandria, VA 22313-1450.**

## Privacy Act Statement

The Privacy Act of 1974 (P.L. 93-579) requires that you be given certain information in connection with your submission of the attached form relating to a patent application or patent. Accordingly, pursuant to the requirements of the Act, please be advised that: (1) the general authority for the collection of this information is 35 U.S.C. 2(b)(2); (2) furnishing of the information solicited is voluntary; and (3) the principal purpose for which the information is used by the U.S. Patent and Trademark Office is to process and/or examine your submission related to a patent application or patent. If you do not furnish the requested information, the U.S. Patent and Trademark Office may not be able to process and/or examine your submission, which may result in termination of proceedings or abandonment of the application or expiration of the patent.

The information provided by you in this form will be subject to the following routine uses:

1. The information on this form will be treated confidentially to the extent allowed under the Freedom of Information Act (5 U.S.C. 552) and Privacy Act (5 U.S.C. 552a). Records from this system of records may be disclosed to the Department of Justice to determine whether the Freedom of Information Act requires disclosure of these records.
2. A record from this system of records may be disclosed, as a routine use, in the course of presenting evidence to a court, magistrate, or administrative tribunal, including disclosures to opposing counsel in the course of settlement negotiations.
3. A record in this system of records may be disclosed, as a routine use, to a Member of Congress submitting a request involving an individual to whom the record pertains, when the individual has requested assistance from the Member with respect to the subject matter of the record.
4. A record in this system of records may be disclosed, as a routine use, to a contractor of the Agency having need for the information in order to perform a contract. Recipients of information shall be required to comply with the requirements of the Privacy Act of 1974, as amended pursuant to 5 U.S.C. 552a(m).
5. A record related to an International Application filed under the Patent Cooperation Treaty in this system of records may be disclosed, as a routine use, to the International Bureau of the World Intellectual Property Organization, pursuant to the Patent Cooperation Treaty.
6. A record in this system of records may be disclosed, as a routine use, to another federal agency for purposes of National Security review pursuant to 50 U.S.C. 181 and for review pursuant to the Atomic Energy Act (42 U.S.C. 218(c)).
7. A record from this system of records may be disclosed, as a routine use, to the Administrator, General Services, or his/her designee, during an inspection of records conducted by GSA as part of that agency's responsibility to recommend improvements in records management practices and programs, under authority of 44 U.S.C. 2904 and 2906. Such disclosure shall be made in accordance with the GSA regulations governing inspection of records for this purpose, and any other relevant (i.e., GSA or Commerce) directive. Such disclosure shall not be used to make determinations about individuals.
8. A record from this system of records may be disclosed, as a routine use, to the public after either publication of the application pursuant to 35 U.S.C. 122(b) or issuance of a patent pursuant to 35 U.S.C. 151. Further, a record may be disclosed, subject to the limitations of 35 U.S.C. 1.14, as a routine use, to the public if the record was filed in an application which became abandoned or in which the proceedings were terminated and which application is referenced by either a published application, an application open to public inspections or an issued patent.
9. A record from this system of records may be disclosed, as a routine use, to a Federal, State, or local law enforcement agency, if the USPTO becomes aware of a violation or potential violation of law or regulation.

## Electronic Patent Application Fee Transmittal

<b>Application Number:</b>	13675665			
<b>Filing Date:</b>	13-Nov-2012			
<b>Title of Invention:</b>	PERCUTANEOUSLY IMPLANTABLE REPLACEMENT HEART VALVE DEVICE AND METHOD OF MAKING SAME			
<b>First Named Inventor/Applicant Name:</b>				
<b>Filer:</b>	Mark Lauren Yaskanin/Carol Donahue			
<b>Attorney Docket Number:</b>	109978.10101			
Filed as Small Entity				
<b>Utility under 35 USC 111(a) Filing Fees</b>				
<b>Description</b>	<b>Fee Code</b>	<b>Quantity</b>	<b>Amount</b>	<b>Sub-Total in USD(\$)</b>
<b>Basic Filing:</b>				
Utility filing Fee (Electronic filing)	4011	1	70	70
Utility Search Fee	2111	1	300	300
Utility Examination Fee	2311	1	360	360
<b>Pages:</b>				
<b>Claims:</b>				
<b>Miscellaneous-Filing:</b>				
Late Filing Fee for Oath or Declaration	2051	1	70	70
<b>Petition:</b>				

Description	Fee Code	Quantity	Amount	Sub-Total in USD(\$)
<b>Patent-Appeals-and-Interference:</b>				
<b>Post-Allowance-and-Post-Issuance:</b>				
<b>Extension-of-Time:</b>				
Extension - 5 months with \$0 paid	2255	1	1500	1500
<b>Miscellaneous:</b>				
<b>Total in USD (\$)</b>				<b>2300</b>

## Electronic Acknowledgement Receipt

<b>EFS ID:</b>	16286632
<b>Application Number:</b>	13675665
<b>International Application Number:</b>	
<b>Confirmation Number:</b>	1995
<b>Title of Invention:</b>	PERCUTANEOUSLY IMPLANTABLE REPLACEMENT HEART VALVE DEVICE AND METHOD OF MAKING SAME
<b>First Named Inventor/Applicant Name:</b>	
<b>Customer Number:</b>	29880
<b>Filer:</b>	Mark Lauren Yaskanin/Carol Donahue
<b>Filer Authorized By:</b>	Mark Lauren Yaskanin
<b>Attorney Docket Number:</b>	109978.10101
<b>Receipt Date:</b>	11-JUL-2013
<b>Filing Date:</b>	13-NOV-2012
<b>Time Stamp:</b>	15:35:54
<b>Application Type:</b>	Utility under 35 USC 111(a)

### Payment information:

Submitted with Payment	yes
Payment Type	Credit Card
Payment was successfully received in RAM	\$2300
RAM confirmation Number	2221
Deposit Account	501943
Authorized User	YASKANIN, MARK L.

The Director of the USPTO is hereby authorized to charge indicated fees and credit any overpayment as follows:

Charge any Additional Fees required under 37 C.F.R. Section 1.16 (National application filing, search, and examination fees)

Charge any Additional Fees required under 37 C.F.R. Section 1.17 (Patent application and reexamination processing fees)

Charge any Additional Fees required under 37 C.F.R. Section 1.19 (Document supply fees)

Charge any Additional Fees required under 37 C.F.R. Section 1.20 (Post Issuance fees)

Charge any Additional Fees required under 37 C.F.R. Section 1.21 (Miscellaneous fees and charges)

**File Listing:**

Document Number	Document Description	File Name	File Size(Bytes)/ Message Digest	Multi Part /.zip	Pages (if appl.)
1	Applicant Response to Pre-Exam Formalities Notice	Colibri_10101_Reponse_to_Missing_Parts_Notice.PDF	114895 166085ee25d55a6089835a2ab4d40238ee486e1	no	1
<b>Warnings:</b>					
<b>Information:</b>					
2	Oath or Declaration filed	Colibri_10101_Fish_Executed_Declaration.pdf	428920 9eec576478db0a4926d8a10e1c6329eb33b341b5	no	1
<b>Warnings:</b>					
<b>Information:</b>					
3	Oath or Declaration filed	Colibri_10101_Induni_Executed_Declaration.pdf	1808386 b97e7c6ae575d9e093a5efcd014f751f3cf6808b	no	2
<b>Warnings:</b>					
<b>Information:</b>					
4	Oath or Declaration filed	Colibri_10101_Meiija_Executed_Declaration.pdf	229513 2646e7826e018233d058fb98dc3d7c5120dc3440	no	1
<b>Warnings:</b>					
<b>Information:</b>					
5	Extension of Time	Colibri_10101_Extension_of_Time.pdf	129573 d85d9435a15bf375406770a10f9e7b22c595fb12	no	2
<b>Warnings:</b>					
<b>Information:</b>					
6		Colibri_10101_Preliminary_Amendment.pdf	126341 4276c5087e5a4f5013de9ad11c4204c0f78c17705	yes	6
	<b>Multipart Description/PDF files in .zip description</b>				
	<b>Document Description</b>		<b>Start</b>	<b>End</b>	
	Preliminary Amendment		1	1	
	Claims		2	5	
Applicant Arguments/Remarks Made in an Amendment		6	6		
<b>Warnings:</b>					

<b>Information:</b>					
7	Oath or Declaration filed	Colibri_10101_Paniagua_Executed_Declaration.PDF	489581 58e6a244c2213f057765dd5356720380289efc6d	no	1
<b>Warnings:</b>					
<b>Information:</b>					
8	Oath or Declaration filed	Colibri_10101_Lopez-Jimenez_Executed_Declaration.PDF	290504 ba4182f11e5954f2f36a443d0e86c1b1723f533c	no	1
<b>Warnings:</b>					
<b>Information:</b>					
9	Application Data Sheet	Colibri_10101_updated_ADS.PDF	2898598 fc860283f2e2e1283adda5fb2737953013fd3043a	no	8
<b>Warnings:</b>					
<b>Information:</b>					
This is not an USPTO supplied ADS fillable form					
10	Fee Worksheet (SB06)	fee-info.pdf	39052 f07a0594d1afaacb1f3bbfd3f510368ee865b2bc	no	2
<b>Warnings:</b>					
<b>Information:</b>					
<b>Total Files Size (in bytes):</b>			6555363		
<p><b>This Acknowledgement Receipt evidences receipt on the noted date by the USPTO of the indicated documents, characterized by the applicant, and including page counts, where applicable. It serves as evidence of receipt similar to a Post Card, as described in MPEP 503.</b></p> <p><b><u>New Applications Under 35 U.S.C. 111</u></b>  <b>If a new application is being filed and the application includes the necessary components for a filing date (see 37 CFR 1.53(b)-(d) and MPEP 506), a Filing Receipt (37 CFR 1.54) will be issued in due course and the date shown on this Acknowledgement Receipt will establish the filing date of the application.</b></p> <p><b><u>National Stage of an International Application under 35 U.S.C. 371</u></b>  <b>If a timely submission to enter the national stage of an international application is compliant with the conditions of 35 U.S.C. 371 and other applicable requirements a Form PCT/DO/EO/903 indicating acceptance of the application as a national stage submission under 35 U.S.C. 371 will be issued in addition to the Filing Receipt, in due course.</b></p> <p><b><u>New International Application Filed with the USPTO as a Receiving Office</u></b>  <b>If a new international application is being filed and the international application includes the necessary components for an international filing date (see PCT Article 11 and MPEP 1810), a Notification of the International Application Number and of the International Filing Date (Form PCT/RO/105) will be issued in due course, subject to prescriptions concerning national security, and the date shown on this Acknowledgement Receipt will establish the international filing date of the application.</b></p>					

<b>PATENT APPLICATION FEE DETERMINATION RECORD</b> Substitute for Form PTO-875	Application or Docket Number 13/675,665
---	--

APPLICATION AS FILED - PART I			SMALL ENTITY		OR	OTHER THAN SMALL ENTITY	
	(Column 1)	(Column 2)					
FOR	NUMBER FILED	NUMBER EXTRA	RATE(\$)	FEE(\$)		RATE(\$)	FEE(\$)
BASIC FEE <small>(37 CFR 1.16(a), (b), or (c))</small>	N/A	N/A	N/A	70		N/A	
SEARCH FEE <small>(37 CFR 1.16(k), (l), or (m))</small>	N/A	N/A	N/A	300		N/A	
EXAMINATION FEE <small>(37 CFR 1.16(o), (p), or (q))</small>	N/A	N/A	N/A	360		N/A	
TOTAL CLAIMS <small>(37 CFR 1.16(i))</small>	14	minus 20 = *	x 40 =	0.00	OR		
INDEPENDENT CLAIMS <small>(37 CFR 1.16(h))</small>	3	minus 3 = *	x 210 =	0.00			
APPLICATION SIZE FEE <small>(37 CFR 1.16(s))</small>	If the specification and drawings exceed 100 sheets of paper, the application size fee due is \$310 (\$155 for small entity) for each additional 50 sheets or fraction thereof. See 35 U.S.C. 41(a)(1)(G) and 37 CFR 1.16(s).			0.00			
MULTIPLE DEPENDENT CLAIM PRESENT <small>(37 CFR 1.16(j))</small>				0.00			
			TOTAL	730		TOTAL	

\* If the difference in column 1 is less than zero, enter "0" in column 2.

APPLICATION AS AMENDED - PART II					SMALL ENTITY		OR	OTHER THAN SMALL ENTITY		
	(Column 1)	(Column 2)	(Column 3)							
AMENDMENT A		CLAIMS REMAINING AFTER AMENDMENT	HIGHEST NUMBER PREVIOUSLY PAID FOR	PRESENT EXTRA	RATE(\$)	ADDITIONAL FEE(\$)		RATE(\$)	ADDITIONAL FEE(\$)	
	Total <small>(37 CFR 1.16(i))</small>	*	Minus	**	x	=	OR	x	=	
	Independent <small>(37 CFR 1.16(h))</small>	*	Minus	***	x	=	OR	x	=	
	Application Size Fee <small>(37 CFR 1.16(s))</small>							OR		
	FIRST PRESENTATION OF MULTIPLE DEPENDENT CLAIM <small>(37 CFR 1.16(j))</small>							OR		
					TOTAL ADD'L FEE		OR	TOTAL ADD'L FEE		
AMENDMENT B		CLAIMS REMAINING AFTER AMENDMENT	HIGHEST NUMBER PREVIOUSLY PAID FOR	PRESENT EXTRA	RATE(\$)	ADDITIONAL FEE(\$)		RATE(\$)	ADDITIONAL FEE(\$)	
	Total <small>(37 CFR 1.16(i))</small>	*	Minus	**	x	=	OR	x	=	
	Independent <small>(37 CFR 1.16(h))</small>	*	Minus	***	x	=	OR	x	=	
	Application Size Fee <small>(37 CFR 1.16(s))</small>							OR		
	FIRST PRESENTATION OF MULTIPLE DEPENDENT CLAIM <small>(37 CFR 1.16(j))</small>							OR		
					TOTAL ADD'L FEE		OR	TOTAL ADD'L FEE		

\* If the entry in column 1 is less than the entry in column 2, write "0" in column 3.  
 \*\* If the "Highest Number Previously Paid For" IN THIS SPACE is less than 20, enter "20".  
 \*\*\* If the "Highest Number Previously Paid For" IN THIS SPACE is less than 3, enter "3".  
 The "Highest Number Previously Paid For" (Total or Independent) is the highest found in the appropriate box in column 1.





UNITED STATES PATENT AND TRADEMARK OFFICE

UNITED STATES DEPARTMENT OF COMMERCE
United States Patent and Trademark Office
Address: COMMISSIONER FOR PATENTS
P.O. Box 1450
Alexandria, Virginia 22313-1450
www.uspto.gov

Table with 4 columns: APPLICATION NUMBER (13/675,665), FILING OR 371(C) DATE (11/13/2012), FIRST NAMED APPLICANT (David Paniagua), ATTY. DOCKET NO./TITLE (109978.10101)

CONFIRMATION NO. 1995

FORMALITIES LETTER

29880
FOX ROTHSCHILD LLP
PRINCETON PIKE CORPORATE CENTER
997 LENOX DRIVE
BLDG. #3
LAWRENCEVILLE, NJ 08648



Date Mailed: 07/19/2013

NOTICE OF INCOMPLETE REPLY (NONPROVISIONAL)

Filing Date Granted

The U.S. Patent and Trademark Office has received your reply on 07/11/2013 to the Notice to File Missing Parts (Notice) mailed 12/12/2012 and it has been entered into the nonprovisional application. The reply, however, does not include the following items required in the Notice. A complete reply must be timely filed to prevent ABANDONMENT of the above-identified application. Replies should be mailed to: Mail Stop Missing Parts, Commissioner for Patents, P.O. Box 1450, Alexandria VA 22313-1450.

Applicant is given TWO MONTHS from the date of the Notice to File Missing Parts (Notice) mailed 12/12/2012 within which to file all required items and pay any fees required below to avoid abandonment. Extensions of time may be obtained by filing a petition accompanied by the extension fee under the provisions of 37 CFR 1.136(a).

Items Required to Avoid Abandonment:

The required items noted below SHOULD be filed along with any items required above. The filing date of this nonprovisional application will be the date of receipt of the items required above.

The application is informal since it does not comply with the regulations for the reason(s) indicated below.

The required item(s) identified below must be timely submitted to avoid abandonment:

- Replacement drawings in compliance with 37 CFR 1.84 and 37 CFR 1.121(d) are required. The drawings submitted are not acceptable because:
• The drawings must be reasonably free from erasures and must be free from alterations, overwriting, interlineations, folds, and copy marks. See Figure(s) 9b, 9c.

Applicant is cautioned that correction of the above items may cause the specification and drawings page count to exceed 100 pages. If the specification and drawings exceed 100 pages, applicant will need to submit the required application size fee.

Replies must be received in the USPTO within the set time period or must include a proper Certificate of Mailing or Transmission under 37 CFR 1.8 with a mailing or transmission date within the set time period. For more information and a suggested format, see Form PTO/SB/92 and MPEP 512.

Replies should be mailed to:

Mail Stop Missing Parts  
Commissioner for Patents  
P.O. Box 1450  
Alexandria VA 22313-1450

Registered users of EFS-Web may alternatively submit their reply to this notice via EFS-Web.

<https://portal.uspto.gov/authenticate/AuthenticateUserLocalEPF.html>

For more information about EFS-Web please call the USPTO Electronic Business Center at **1-866-217-9197** or visit our website at <http://www.uspto.gov/ebc>.

If you are not using EFS-Web to submit your reply, you must include a copy of this notice.

*/eggolla/*

---

Office of Data Management, Application Assistance Unit (571) 272-4000, or (571) 272-4200, or 1-888-786-0101



UNITED STATES PATENT AND TRADEMARK OFFICE

UNITED STATES DEPARTMENT OF COMMERCE
United States Patent and Trademark Office
Address: COMMISSIONER FOR PATENTS
P.O. Box 1450
Alexandria, Virginia 22313-1450
www.uspto.gov

Table with 4 columns: APPLICATION NUMBER (13/675,665), FILING OR 371(C) DATE (11/13/2012), FIRST NAMED APPLICANT (David Paniagua), ATTY. DOCKET NO./TITLE (109978.10101)

29880
FOX ROTHSCHILD LLP
PRINCETON PIKE CORPORATE CENTER
997 LENOX DRIVE
BLDG. #3
LAWRENCEVILLE, NJ 08648

CONFIRMATION NO. 1995
ABANDONMENT/TERMINATION
LETTER



Date Mailed: 07/19/2013

NOTICE OF ABANDONMENT UNDER 37 CFR 1.53 (f) OR (g)

The above-identified application is abandoned for failure to timely or properly reply to the Notice to File Missing Parts (Notice) mailed on 12/12/2012.

- The reply received on 07/11/2013 was insufficient. The reply did not include:
Replacement drawings as required.

If a complete reply to the notice was previously filed by applicant within the time period set forth in the notice, applicant may request for reconsideration of the holding of abandonment within 2 months from the mailing of this notice of abandonment by filing a petition to withdraw the holding of abandonment under 37 CFR 1.181(a). No petition fee is required. The petition must be accompanied by a true copy of the originally filed reply and the item(s) identified in one of the following:

- A properly itemized date-stamped postcard receipt (see MPEP § 503);
2. If the originally filed reply included a certificate of mailing or transmission in compliance with 37 CFR 1.8(a), a copy of the certificate of mailing or transmission and a statement in compliance with 37 CFR 1.8(b) (see MPEP § 512); or
3. If the reply was filed via "Express Mail," a submission satisfying the requirements of 37 CFR 1.10(e) including, for example, a copy of the "Express Mail" mailing label showing the "date-in" (see MPEP § 513).

Any petition to withdraw the holding of abandonment should be directed to OPAP.

If applicant did not previously file a complete reply within the time period set forth in the notice, applicant may file a petition to revive the application under 37 CFR 1.137.

Under 37 CFR 1.137(a), a petition requesting the application be revived on the grounds of UNAVOIDABLE DELAY must be filed promptly after the applicant becomes aware of the abandonment and such petition must be accompanied by: (1) an adequate showing of the cause of unavoidable delay; (2) the required reply to the above-identified Notice; (3) the petition fee set forth in 37 CFR 1.17(l); and (4) a terminal disclaimer if required by 37 CFR 1.137(d). See MPEP § 711.03(c) and Form PTO/SB/61.

Under 37 CFR 1.137(b), a petition requesting the application be revived on the grounds of UNINTENTIONAL DELAY must be filed promptly after applicant becomes aware of the abandonment and such petition must be accompanied by: (1) a statement that the entire delay was unintentional; (2) the required reply to the above-identified Notice; (3) the petition fee set forth in 37 CFR 1.17(m); and (4) a terminal disclaimer if required by 37 CFR 1.137(d). See MPEP § 711.03(c) and Form PTO/SB/64.

Any questions concerning petitions to revive should be directed to the "Office of Petitions" at (571) 272-3282.

A copy of this notice MUST be returned with the reply.

/mohamed/

---

Office of Data Management, Application Assistance Unit (571) 272-4000, or (571) 272-4200, or 1-888-786-0101

Doc Code: PET.OP

Document Description: Petition for Review by the Office of Petitions

PTO/SB/64 (03-13)

Approved for use through 03/31/2013. OMB 0651-0031

U.S. Patent and Trademark Office; U.S. DEPARTMENT OF COMMERCE

Under the Paperwork Reduction Act of 1995, no persons are required to respond to a collection of information unless it displays a valid OMB control number.

<b>PETITION FOR REVIVAL OF AN APPLICATION FOR PATENT ABANDONED UNINTENTIONALLY UNDER 37 CFR 1.137(b)</b>	Docket Number (Optional) <b>109978.10101</b>
Page 1 of 2	

First named inventor: David PANIAGUA

Application No.: 13/675,665 Art Unit: 3738

Filed: 2012-11-13 Examiner: Not Yet Assigned

Title: **Percutaneously Implantable Replacement Heart Valve Device and Method of Making Same**

Attention: Office of Petitions  
**Mail Stop Petition**  
 Commissioner for Patents  
 P.O. Box 1450  
 Alexandria, VA 22313-1450  
 FAX (571) 273-8300

NOTE: If information or assistance is needed in completing this form, please contact the Office of Petitions at (571) 272-3282.

The above-identified application became abandoned for failure to file a timely and proper reply to a notice or action by the United States Patent and Trademark Office. The date of abandonment is the day after the expiration date of the period set for reply in the Office notice or action plus any extensions of time actually obtained.

**APPLICANT HEREBY PETITIONS FOR REVIVAL OF THIS APPLICATION.**

NOTE: A grantable petition requires the following items:

- (1) Petition fee;
- (2) Reply and/or issue fee;
- (3) Terminal disclaimer with disclaimer fee – required for all utility and plant applications filed before June 8, 1995, and for all design applications; and
- (4) Statement that the entire delay was unintentional.

**1. Petition fee**

- Small entity fee \$ 950.00 (37 CFR 1.17(m)). Applicant asserts small entity status. See 37 CFR 1.27.
- Micro entity fee \$ \_\_\_\_\_ (37 CFR 1.17(m)). Applicant certifies micro entity status. See 37 CFR 1.29. Form PTO/SB/15A or B or equivalent must either be enclosed or have been submitted previously.
- Undiscounted fee \$ \_\_\_\_\_ (37 CFR 1.17(m)).

**2. Reply and/or fee**

- A The reply and/or fee to the above-noted Office notice or action in the form of  
Reply to Notice of Incomplete Reply and Submission of Replacement Drawings (identify the type of reply):
- has been filed previously on \_\_\_\_\_.
  - is enclosed herewith.
- B The issue fee and publication fee (if applicable) of \$ \_\_\_\_\_
- has been paid previously on \_\_\_\_\_.
  - is enclosed herewith.

This collection of information is required by 37 CFR 1.137(b). The information is required to obtain or retain a benefit by the public which is to file (and by the USPTO to process) an application. Confidentiality is governed by 35 U.S.C. 122 and 37 CFR 1.11, 1.14 and 41.6. This collection is estimated to take 1 hour to complete, including gathering, preparing, and submitting the completed application form to the USPTO. Time will vary depending upon the individual case. Any comments on the amount of time you require to complete this form and/or suggestions for reducing this burden, should be sent to the Chief Information Officer, U.S. Patent and Trademark Office, U.S. Department of Commerce, P.O. Box 1450, Alexandria, VA 22313-1450. DO NOT SEND FEES OR COMPLETED FORMS TO THIS ADDRESS. SEND TO: **Mail Stop Petition, Commissioner for Patents, P.O. Box 1450, Alexandria, VA 22313-1450.**

*If you need assistance in completing the form, call 1-800-PTO-9199 and select option 2.*

Doc Code: PET.OP

Document Description: Petition for Review by the Office of Petitions

PTO/SB/64 (03-13)

Approved for use through 03/31/2013. OMB 0651-0031

U.S. Patent and Trademark Office; U.S. DEPARTMENT OF COMMERCE

Under the Paperwork Reduction Act of 1995, no persons are required to respond to a collection of information unless it displays a valid OMB control number.

**PETITION FOR REVIVAL OF AN APPLICATION FOR PATENT  
ABANDONED UNINTENTIONALLY UNDER 37 CFR 1.137(b)**

Page 2 of 2

**3. Terminal disclaimer with disclaimer fee**

- Since this utility/plant application was filed on or after June 8, 1995, no terminal disclaimer is required.
- A terminal disclaimer (and disclaimer fee (37 CFR 1.20(d)) of \$ \_\_\_\_\_) disclaiming the required period of time is enclosed herewith (see PTO/SB/63).

**4. STATEMENT:** The entire delay in filing the required reply from the due date for the required reply until the filing of a grantable petition under 37 CFR 1.137(b) was unintentional. [NOTE: The United States Patent and Trademark Office may require additional information if there is a question as to whether either the abandonment or the delay in filing a petition under 37 CFR 1.137(b) was unintentional (MPEP 711.03(c), subsections (II)(C) and (D)):]

**WARNING:**

Petitioner/applicant is cautioned to avoid submitting personal information in documents filed in a patent application that may contribute to identity theft. Personal information such as social security numbers, bank account numbers, or credit card numbers (other than a check or credit card authorization form PTO-2038 submitted for payment purposes) is never required by the USPTO to support a petition or an application. If this type of personal information is included in documents submitted to the USPTO, petitioners/applicants should consider redacting such personal information from the documents before submitting them to the USPTO. Petitioner/applicant is advised that the record of a patent application is available to the public after publication of the application (unless a non-publication request in compliance with 37 CFR 1.213(a) is made in the application) or issuance of a patent. Furthermore, the record from an abandoned application may also be available to the public if the application is referenced in a published application or an issued patent (see 37 CFR 1.14). Checks and credit card authorization forms PTO-2038 submitted for payment purposes are not retained in the application file and therefore are not publicly available.

/ Mark L. Yaskanin /

27 August 2013

Signature

Date

Mark L. Yaskanin

45,246

Typed or Printed Name

Registration Number, if applicable

Customer No. 29880

303.446.3840

Address

Telephone Number

1200 17th St, #975, Denver CO 80202

Address

**Enclosures:**

- Fee Payment
- Reply
- Terminal Disclaimer Form
- Additional sheet(s) containing statements establishing unintentional delay
- Other: Replacement Drawings for Figures 9A-9C

**CERTIFICATE OF MAILING OR TRANSMISSION [37 CFR 1.8(a)]**

I hereby certify that this correspondence is being:

- Deposited with the United States Postal Service on the date shown below with sufficient postage as first class mail in an envelope addressed to: Mail Stop Petition, Commissioner for Patents, P. O. Box 1450, Alexandria, VA 22313-1450.
- Transmitted by facsimile on the date shown below to the United States Patent and Trademark Office at (571) 273-8300.

Date

Signature

Typed or printed name of person signing certificate

## Privacy Act Statement

The **Privacy Act of 1974 (P.L. 93-579)** requires that you be given certain information in connection with your submission of the attached form related to a patent application or patent. Accordingly, pursuant to the requirements of the Act, please be advised that: (1) the general authority for the collection of this information is 35 U.S.C. 2(b)(2); (2) furnishing of the information solicited is voluntary; and (3) the principal purpose for which the information is used by the U.S. Patent and Trademark Office is to process and/or examine your submission related to a patent application or patent. If you do not furnish the requested information, the U.S. Patent and Trademark Office may not be able to process and/or examine your submission, which may result in termination of proceedings or abandonment of the application or expiration of the patent.

The information provided by you in this form will be subject to the following routine uses:

1. The information on this form will be treated confidentially to the extent allowed under the Freedom of Information Act (5 U.S.C. 552) and the Privacy Act (5 U.S.C. 552a). Records from this system of records may be disclosed to the Department of Justice to determine whether disclosure of these records is required by the Freedom of Information Act.
2. A record from this system of records may be disclosed, as a routine use, in the course of presenting evidence to a court, magistrate, or administrative tribunal, including disclosures to opposing counsel in the course of settlement negotiations.
3. A record in this system of records may be disclosed, as a routine use, to a Member of Congress submitting a request involving an individual, to whom the record pertains, when the individual has requested assistance from the Member with respect to the subject matter of the record.
4. A record in this system of records may be disclosed, as a routine use, to a contractor of the Agency having need for the information in order to perform a contract. Recipients of information shall be required to comply with the requirements of the Privacy Act of 1974, as amended, pursuant to 5 U.S.C. 552a(m).
5. A record related to an International Application filed under the Patent Cooperation Treaty in this system of records may be disclosed, as a routine use, to the International Bureau of the World Intellectual Property Organization, pursuant to the Patent Cooperation Treaty.
6. A record in this system of records may be disclosed, as a routine use, to another federal agency for purposes of National Security review (35 U.S.C. 181) and for review pursuant to the Atomic Energy Act (42 U.S.C. 218(c)).
7. A record from this system of records may be disclosed, as a routine use, to the Administrator, General Services, or his/her designee, during an inspection of records conducted by GSA as part of that agency's responsibility to recommend improvements in records management practices and programs, under authority of 44 U.S.C. 2904 and 2906. Such disclosure shall be made in accordance with the GSA regulations governing inspection of records for this purpose, and any other relevant (*i.e.*, GSA or Commerce) directive. Such disclosure shall not be used to make determinations about individuals.
8. A record from this system of records may be disclosed, as a routine use, to the public after either publication of the application pursuant to 35 U.S.C. 122(b) or issuance of a patent pursuant to 35 U.S.C. 151. Further, a record may be disclosed, subject to the limitations of 37 CFR 1.14, as a routine use, to the public if the record was filed in an application which became abandoned or in which the proceedings were terminated and which application is referenced by either a published application, an application open to public inspection or an issued patent.
9. A record from this system of records may be disclosed, as a routine use, to a Federal, State, or local law enforcement agency, if the USPTO becomes aware of a violation or potential violation of law or regulation.

IN THE UNITED STATES PATENT AND TRADEMARK OFFICE

In Re the Application of: ) Confirmation No.: 1995  
)  
PANIAGUA et al. ) Group Art Unit: 3738  
)  
Application No.: 13/675,665 ) Examiner: NOT YET ASSIGNED  
)  
Filed: November 13, 2012 )  
)  
Atty. File No.: 109978.10101 )  
)  
For: PERCUTANEOUSLY )  
IMPLANTABLE REPLACEMENT )  
HEART VALVE DEVICE AND )  
METHOD OF MAKING SAME )

**RESPONSE TO NOTICE OF  
INCOMPLETE REPLY AND  
SUBMISSION OF  
REPLACEMENT DRAWINGS**

*(Filed Electronically)*

Commissioner for Patents  
P.O. Box 1450  
Alexandria Virginia 22313-1450

**Certificate of EFS-Web Transmission**  
I hereby certify that this correspondence is being electronically transmitted to the U.S. Patent & Trademark Office by the EFS-Web system on 27 August 2013.  
Typed or printed name of person signing this certificate:  
Carol Donahue  
Signature: / Carol Donahue /

Dear Sir:

In further response to the December 12, 2012 Notice to File Missing Parts, and in response the July 19, 2013 Notice of Abandonment and Notice of Incomplete Reply in connection with the above-identified application, Applicants herewith submit a Petition For Revival Of An Unintentionally Abandoned Application and replacement Figures 9A-9C. The Notice to File Missing Parts required submission of replacement drawings for Figures 9B and 9C. It is noted that the replacement Figures 9A-9C submitted herewith were printed in Applicants' U.S. Patent No. 8,109,995, which shares common priority with the present application to U.S. Patent Application No. 10/887,688. Please replace Figures 9A-9C currently on file with the attached replacement drawings. Applicants believe no new matter has been added with submittal of replacement drawings 9A-9C.



Response to Notice of Incomplete Reply  
U.S. Patent Application No. 13/675,665  
Filed on August 27, 2013

The requisite small entity fee as set forth in in 37 CFR 1.17(m) for the revival petition is also submitted. Please charge any over or under-payment to Deposit Account No. 50-1943.

Respectfully submitted,

FOX ROTHSCHILD LLP

/ Mark L. Yaskanin /

Mark L. Yaskanin

Registration No. 45,246

Customer No. 29880

Phone: (303) 446-3840

Facsimile: (303) 446-3841

Dated: 27 August 2013

Response to Notice of Incomplete Reply  
U.S. Patent Application No. 13/675,665  
Filed on August 27, 2013

## REPLACEMENT DRAWINGS

REPLACEMENT SHEET

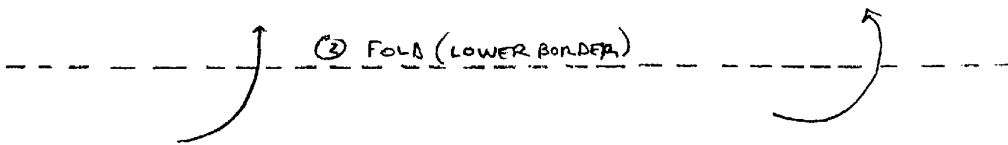
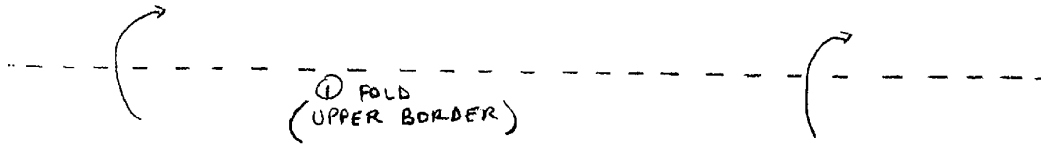


FIG. 9A

REPLACEMENT SHEET

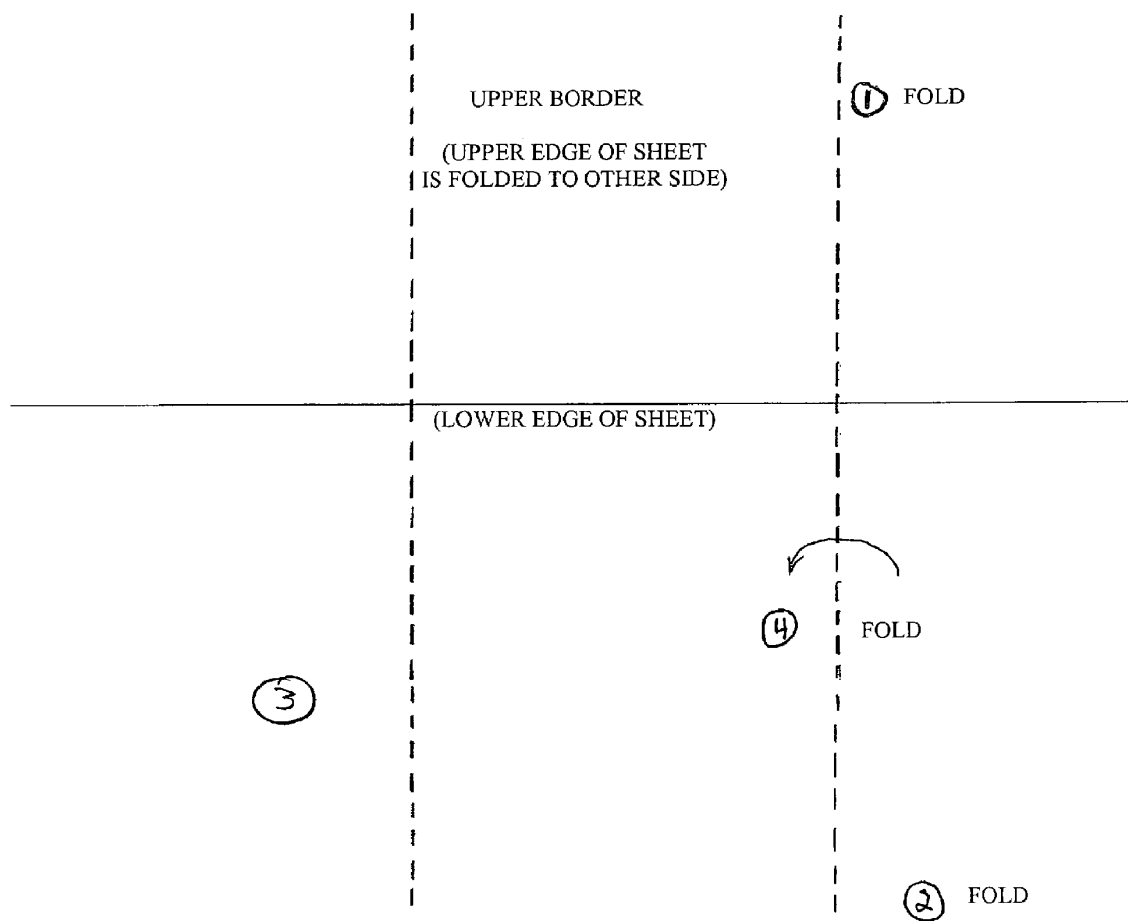


FIG. 9B

REPLACEMENT SHEET

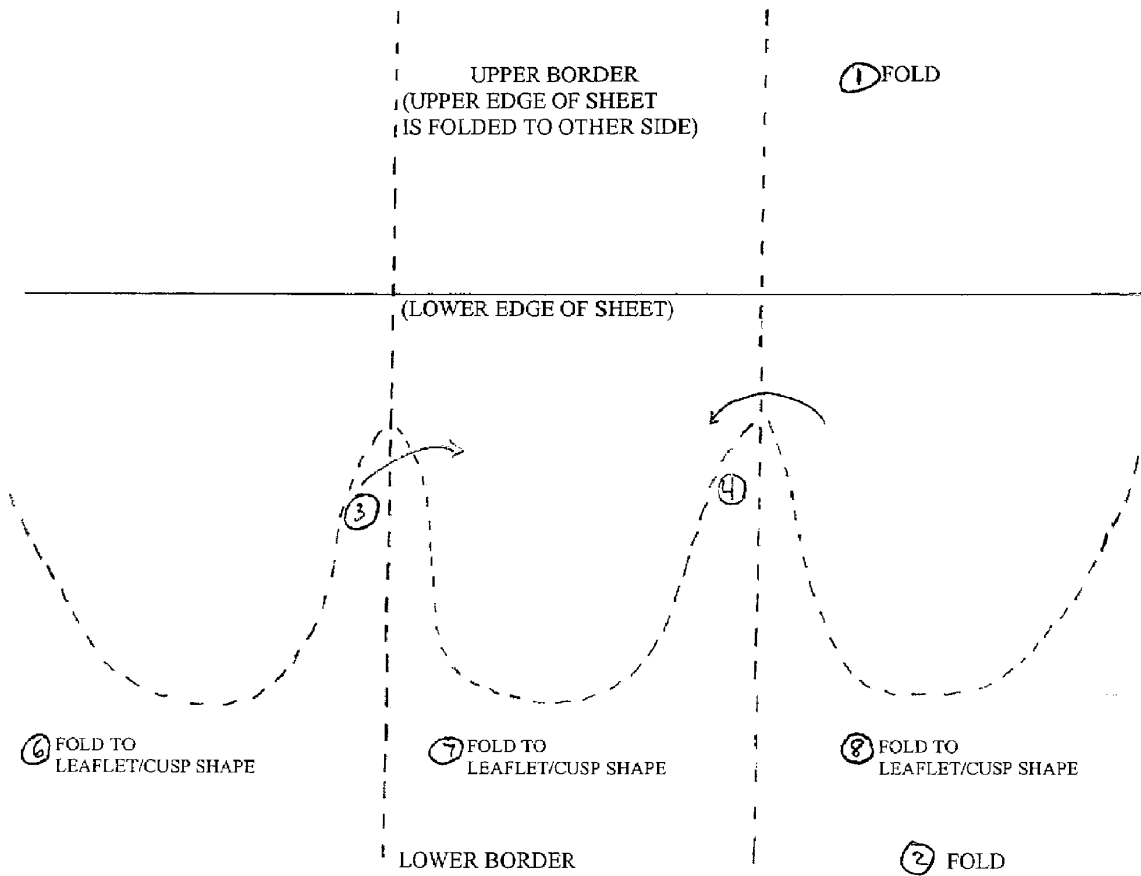


FIG. 9C

## Electronic Patent Application Fee Transmittal

<b>Application Number:</b>	13675665				
<b>Filing Date:</b>	13-Nov-2012				
<b>Title of Invention:</b>	PERCUTANEOUSLY IMPLANTABLE REPLACEMENT HEART VALVE DEVICE AND METHOD OF MAKING SAME				
<b>First Named Inventor/Applicant Name:</b>	David Paniagua				
<b>Filer:</b>	Mark Lauren Yaskanin/Carol Donahue				
<b>Attorney Docket Number:</b>	109978.10101				
Filed as Small Entity					
<b>Utility under 35 USC 111(a) Filing Fees</b>					
<b>Description</b>	<b>Fee Code</b>	<b>Quantity</b>	<b>Amount</b>	<b>Sub-Total in USD(\$)</b>	
<b>Basic Filing:</b>					
<b>Pages:</b>					
<b>Claims:</b>					
<b>Miscellaneous-Filing:</b>					
<b>Petition:</b>					
Petition-Revive Unintent. Abandoned Appl	2453	1	950	950	
<b>Patent-Appeals-and-Interference:</b>					
<b>Post-Allowance-and-Post-Issuance:</b>					
<b>Extension-of-Time:</b>					

Description	Fee Code	Quantity	Amount	Sub-Total in USD(\$)
<b>Miscellaneous:</b>				
<b>Total in USD (\$)</b>				<b>950</b>

## Electronic Acknowledgement Receipt

<b>EFS ID:</b>	16699288
<b>Application Number:</b>	13675665
<b>International Application Number:</b>	
<b>Confirmation Number:</b>	1995
<b>Title of Invention:</b>	PERCUTANEOUSLY IMPLANTABLE REPLACEMENT HEART VALVE DEVICE AND METHOD OF MAKING SAME
<b>First Named Inventor/Applicant Name:</b>	David Paniagua
<b>Customer Number:</b>	29880
<b>Filer:</b>	Mark Lauren Yaskanin/Carol Donahue
<b>Filer Authorized By:</b>	Mark Lauren Yaskanin
<b>Attorney Docket Number:</b>	109978.10101
<b>Receipt Date:</b>	27-AUG-2013
<b>Filing Date:</b>	13-NOV-2012
<b>Time Stamp:</b>	17:12:12
<b>Application Type:</b>	Utility under 35 USC 111(a)

### Payment information:

Submitted with Payment	yes
Payment Type	Credit Card
Payment was successfully received in RAM	\$950
RAM confirmation Number	4266
Deposit Account	501943
Authorized User	YASKANIN, MARK L.

The Director of the USPTO is hereby authorized to charge indicated fees and credit any overpayment as follows:

Charge any Additional Fees required under 37 C.F.R. Section 1.16 (National application filing, search, and examination fees)

Charge any Additional Fees required under 37 C.F.R. Section 1.17 (Patent application and reexamination processing fees)



Charge any Additional Fees required under 37 C.F.R. Section 1.19 (Document supply fees)  
 Charge any Additional Fees required under 37 C.F.R. Section 1.20 (Post Issuance fees)  
 Charge any Additional Fees required under 37 C.F.R. Section 1.21 (Miscellaneous fees and charges)

**File Listing:**

Document Number	Document Description	File Name	File Size(Bytes)/ Message Digest	Multi Part /.zip	Pages (if appl.)
1	Petition for review by the Office of Petitions.	Colibri_10101_Petition.pdf	261481 5cd54b71743e73b81701fc651dc8ff4d80975a3	no	3

**Warnings:**

**Information:**

2		Colibri_10101_Response_to_Notice_of_Incomplete_Reply_2013-08-27.PDF	190741 88e47b9171d9795a3849da26a0a3a47b03d8cb52	yes	6
---	--	---	--	-----	---

**Multipart Description/PDF files in .zip description**

Document Description	Start	End
Applicant Response to Pre-Exam Formalities Notice	1	2
Drawings-only black and white line drawings	3	6

**Warnings:**

**Information:**

3	Fee Worksheet (SB06)	fee-info.pdf	30648 3e4fde40e5a5f82ee5e8e21c3925a6e2a17cb59b	no	2
---	----------------------	--------------	---	----	---

**Warnings:**

**Information:**

**Total Files Size (in bytes):** 482870

This Acknowledgement Receipt evidences receipt on the noted date by the USPTO of the indicated documents, characterized by the applicant, and including page counts, where applicable. It serves as evidence of receipt similar to a Post Card, as described in MPEP 503.

**New Applications Under 35 U.S.C. 111**

If a new application is being filed and the application includes the necessary components for a filing date (see 37 CFR 1.53(b)-(d) and MPEP 506), a Filing Receipt (37 CFR 1.54) will be issued in due course and the date shown on this Acknowledgement Receipt will establish the filing date of the application.

**National Stage of an International Application under 35 U.S.C. 371**

If a timely submission to enter the national stage of an international application is compliant with the conditions of 35 U.S.C. 371 and other applicable requirements a Form PCT/DO/EO/903 indicating acceptance of the application as a national stage submission under 35 U.S.C. 371 will be issued in addition to the Filing Receipt, in due course.

**New International Application Filed with the USPTO as a Receiving Office**

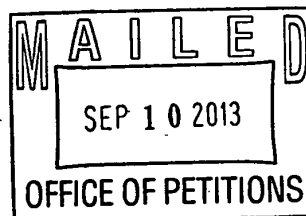
If a new international application is being filed and the international application includes the necessary components for an international filing date (see PCT Article 11 and MPEP 1810), a Notification of the International Application Number and of the International Filing Date (Form PCT/RO/105) will be issued in due course, subject to prescriptions concerning national security, and the date shown on this Acknowledgement Receipt will establish the international filing date of the application.



UNITED STATES PATENT AND TRADEMARK OFFICE

Commissioner for Patents  
United States Patent and Trademark Office  
P.O. Box 1450  
Alexandria, VA 22313-1450  
www.uspto.gov

FOX ROTHSCHILD LLP  
PRINCETON PIKE CORPORATE  
CENTER  
997 LENOX DRIVE  
BLDG. #3  
LAWRENCEVILLE NJ 08648



In re Application of

Paniagua, et al.

Application No. 13/675,665

Filed: November 13, 2012

DECISION ON PETITION

Attorney Docket No. **109978.10101**

This is in response to the petition under 37 CFR 1.137(b)<sup>1</sup> filed August 27, 2013.

The petition under 37 CFR 1.137(b) is **granted**.

The above-cited application became abandoned for failure to reply in a timely manner to the Notice to File Missing Parts of Non-Provisional Application action mailed December 12, 2012, which set a shortened statutory period for reply of three (3) months from its mailing date. A complete response was not received within the allowable period, and the application became abandoned on July 13, 2013. A Notice of Abandonment was mailed July 19, 2013.

The replacement drawings were received on August 27, 2013.

This application is being directed to the Office of Patent Application Processing for further processing.

<sup>1</sup> 37 CFR 1.137(b) states:

(b) Unintentional . If the delay in reply by applicant or patent owner was unintentional, a petition may be filed pursuant to this paragraph to revive an abandoned application, a reexamination prosecution terminated under §§ 1.550(d) or 1.957(b) or limited under § 1.957(c), or a lapsed patent. A grantable petition pursuant to this paragraph must be accompanied by:

- (1) The reply required to the outstanding Office action or notice, unless previously filed;
- (2) The petition fee as set forth in § 1.17(m);
- (3) A statement that the entire delay in filing the required reply from the due date for the reply until the filing of a grantable petition pursuant to this paragraph was unintentional. The Director may require additional information where there is a question whether the delay was unintentional; and
- (4) Any terminal disclaimer (and fee as set forth in § 1.20(d)) required pursuant to paragraph (d) of this section.

Telephone inquiries regarding this decision should be directed to the undersigned at (571) 272-3222.

/Kenya A. McLaughlin/

Kenya A. McLaughlin  
Petitions Attorney  
Office of Petitions

Under the Paperwork Reduction Act of 1995, no persons are required to respond to a collection of information unless it displays a valid OMB control number.

<b>PATENT APPLICATION FEE DETERMINATION RECORD</b> Substitute for Form PTO-875			Application or Docket Number <b>13/675,665</b>	Filing Date <b>11/13/2012</b>	<input type="checkbox"/> To be Mailed		
ENTITY: <input type="checkbox"/> LARGE <input checked="" type="checkbox"/> SMALL <input type="checkbox"/> MICRO							
<b>APPLICATION AS FILED – PART I</b>							
(Column 1)		(Column 2)					
FOR	NUMBER FILED	NUMBER EXTRA	RATE (\$)	FEE (\$)			
<input type="checkbox"/> BASIC FEE (37 CFR 1.16(a), (b), or (c))	N/A	N/A	N/A				
<input type="checkbox"/> SEARCH FEE (37 CFR 1.16(k), (i), or (m))	N/A	N/A	N/A				
<input type="checkbox"/> EXAMINATION FEE (37 CFR 1.16(o), (p), or (q))	N/A	N/A	N/A				
TOTAL CLAIMS (37 CFR 1.16(j))	minus 20 =	*	X \$ =				
INDEPENDENT CLAIMS (37 CFR 1.16(h))	minus 3 =	*	X \$ =				
<input type="checkbox"/> APPLICATION SIZE FEE (37 CFR 1.16(s))	If the specification and drawings exceed 100 sheets of paper, the application size fee due is \$310 (\$155 for small entity) for each additional 50 sheets or fraction thereof. See 35 U.S.C. 41(a)(1)(G) and 37 CFR 1.16(s).						
<input type="checkbox"/> MULTIPLE DEPENDENT CLAIM PRESENT (37 CFR 1.16(j))							
* If the difference in column 1 is less than zero, enter "0" in column 2.			TOTAL				
<b>APPLICATION AS AMENDED – PART II</b>							
(Column 1)		(Column 2)	(Column 3)				
<b>AMENDMENT</b>	<b>09/15/2013</b>	CLAIMS REMAINING AFTER AMENDMENT	HIGHEST NUMBER PREVIOUSLY PAID FOR	PRESENT EXTRA	RATE (\$)	ADDITIONAL FEE (\$)	
	Total (37 CFR 1.16(i))	* 14	Minus	** 20	= 0	X \$40 = 0	
	Independent (37 CFR 1.16(h))	* 3	Minus	***3	= 0	X \$210 = 0	
	<input type="checkbox"/> Application Size Fee (37 CFR 1.16(s))						
	<input type="checkbox"/> FIRST PRESENTATION OF MULTIPLE DEPENDENT CLAIM (37 CFR 1.16(j))						
			TOTAL ADD'L FEE		<b>0</b>		
(Column 1)		(Column 2)	(Column 3)				
<b>AMENDMENT</b>	CLAIMS REMAINING AFTER AMENDMENT	HIGHEST NUMBER PREVIOUSLY PAID FOR	PRESENT EXTRA		RATE (\$)	ADDITIONAL FEE (\$)	
	Total (37 CFR 1.16(i))	*	Minus	**	=	X \$ =	
	Independent (37 CFR 1.16(h))	*	Minus	***	=	X \$ =	
	<input type="checkbox"/> Application Size Fee (37 CFR 1.16(s))						
	<input type="checkbox"/> FIRST PRESENTATION OF MULTIPLE DEPENDENT CLAIM (37 CFR 1.16(j))						
			TOTAL ADD'L FEE				
<p>* If the entry in column 1 is less than the entry in column 2, write "0" in column 3.                  ** If the "Highest Number Previously Paid For" IN THIS SPACE is less than 20, enter "20".                  *** If the "Highest Number Previously Paid For" IN THIS SPACE is less than 3, enter "3".                  The "Highest Number Previously Paid For" (Total or Independent) is the highest number found in the appropriate box in column 1.</p>							

LIE  
/MARY PEOPLES/

This collection of information is required by 37 CFR 1.16. The information is required to obtain or retain a benefit by the public which is to file (and by the USPTO to process) an application. Confidentiality is governed by 35 U.S.C. 122 and 37 CFR 1.14. This collection is estimated to take 12 minutes to complete, including gathering, preparing, and submitting the completed application form to the USPTO. Time will vary depending upon the individual case. Any comments on the amount of time you require to complete this form and/or suggestions for reducing this burden, should be sent to the Chief Information Officer, U.S. Patent and Trademark Office, U.S. Department of Commerce, P.O. Box 1450, Alexandria, VA 22313-1450. DO NOT SEND FEES OR COMPLETED FORMS TO THIS ADDRESS. **SEND TO: Commissioner for Patents, P.O. Box 1450, Alexandria, VA 22313-1450.**  
 If you need assistance in completing the form, call 1-800-PTO-9199 and select option 2.

<b>INFORMATION DISCLOSURE STATEMENT BY APPLICANT</b> ( Not for submission under 37 CFR 1.99)	Application Number		13675665	
	Filing Date		2012-11-13	
	First Named Inventor	David PANIAGUA		
	Art Unit	3738		
	Examiner Name	not assigned		
	Attorney Docket Number	109978.10101		

U.S.PATENTS						Remove
Examiner Initial*	Cite No	Patent Number	Kind Code <sup>1</sup>	Issue Date	Name of Patentee or Applicant of cited Document	Pages,Columns,Lines where Relevant Passages or Relevant Figures Appear
	1					

If you wish to add additional U.S. Patent citation information please click the Add button.

Add

U.S.PATENT APPLICATION PUBLICATIONS						Remove
Examiner Initial*	Cite No	Publication Number	Kind Code <sup>1</sup>	Publication Date	Name of Patentee or Applicant of cited Document	Pages,Columns,Lines where Relevant Passages or Relevant Figures Appear
	1	20020095994		2002-07-25	Vesely et al.	
	2	20020123789		2002-09-05	Francis et al.	
	3	20020128708		2002-09-21	Northrup et al.	
	4	20030078659		2003-04-24	Yang	
	5	20030102000		2003-06-05	Stevens et al.	

<b>INFORMATION DISCLOSURE STATEMENT BY APPLICANT</b> ( Not for submission under 37 CFR 1.99)	Application Number		13675665	
	Filing Date		2012-11-13	
	First Named Inventor	David PANIAGUA		
	Art Unit	3738		
	Examiner Name	not assigned		
	Attorney Docket Number	109978.10101		

	6	20030130727		2003-07-10	Drasler et al.	
	7	20030130729		2003-07-10	Paniagua et al.	
	8	20030130731		2003-07-10	Vidlund et al.	
	9	20030153974		2003-08-14	Spenser et al.	
	10	20030187362		2003-10-02	Murphy et al.	
	11	20030195620		2003-10-16	Huynh et al.	
	12	20030204023		2003-10-30	Koob et al.	
	13	20030212460		2003-11-13	Darois et al.	
	14	20030212462		2003-11-13	Gryska et al.	
	15	20030217415		2003-11-27	Crouch et al.	
	16	20040024452		2004-02-05	Kruse et al.	

<b>INFORMATION DISCLOSURE STATEMENT BY APPLICANT</b> ( Not for submission under 37 CFR 1.99)	Application Number		13675665	
	Filing Date		2012-11-13	
	First Named Inventor	David PANIAGUA		
	Art Unit	3738		
	Examiner Name	not assigned		
	Attorney Docket Number	109978.10101		

	17	20040055608		2004-03-25	Stevens et al.	
	18	20040059418		2004-03-25	McKay et al.	
	19	20040098092		2004-05-20	Butaric et al.	
	20	20040193261		2004-09-30	Berrekouw	
	21	20040243153		2004-12-02	Liddicoat et al.	
	22	20040243229		2004-12-02	Vidlund et al.	
	23	20050004668		2005-01-06	Aklog et al.	
	24	20050027369		2005-02-03	Eldridge et al.	
	25	20050043819		2005-02-24	Schmidt et al.	
	26	20050096673		2005-05-05	Stack et al.	
	27	20050113910		2005-05-26	Paniagua et al.	

<b>INFORMATION DISCLOSURE STATEMENT BY APPLICANT</b> ( Not for submission under 37 CFR 1.99)	Application Number		13675665	
	Filing Date		2012-11-13	
	First Named Inventor	David PANIAGUA		
	Art Unit	3738		
	Examiner Name	not assigned		
	Attorney Docket Number	109978.10101		

	28	20050137681		2005-06-23	Shoemaker et al.	
	29	20050137682		2005-06-23	Justino	
	30	20050142163		2005-06-30	Hunter et al.	
	31	20050147562		2005-07-07	Hunter et al.	
	32	20050147599		2005-07-07	Hunter et al.	
	33	20050147643		2005-07-07	Hunter et al.	
	34	20050148512		2005-07-07	Hunter et al.	
	35	20050158274		2005-07-21	Hunter et al.	
	36	20050159811		2005-07-21	Lane	
	37	20050169958		2005-08-04	Hunter et al.	
	38	20050169959		2005-08-04	Hunter et al.	



<b>INFORMATION DISCLOSURE STATEMENT BY APPLICANT</b> ( Not for submission under 37 CFR 1.99)	Application Number		13675665	
	Filing Date		2012-11-13	
	First Named Inventor	David PANIAGUA		
	Art Unit	3738		
	Examiner Name	not assigned		
	Attorney Docket Number	109978.10101		

	39	20050175657		2005-08-11	Hunter et al.	
	40	20050187618		2005-08-25	Gabbay	
	41	20050191248		2005-09-01	Hunter et al.	
	42	20050228494		2005-10-13	Marquez	
	43	20050246035		2005-11-03	Wolfenbarger, Jr. et al.	
	44	20050247320		2005-11-10	Stack et al.	
	45	20050267529		2005-12-01	Crockett et al.	
	46	20060004439		2006-01-05	Spenser et al.	
	47	20060004443		2006-01-05	Liddicoat et al.	
	48	20060020336		2006-01-26	Liddicoat	
	49	20060025800		2006-02-02	Suresh	

<b>INFORMATION DISCLOSURE STATEMENT BY APPLICANT</b> ( Not for submission under 37 CFR 1.99)	Application Number		13675665	
	Filing Date		2012-11-13	
	First Named Inventor	David PANIAGUA		
	Art Unit		3738	
	Examiner Name	not assigned		
	Attorney Docket Number		109978.10101	

	50	20060041306		2006-02-23	Vidlund et al.	
	51	20060074486		2006-04-06	Liddicoat et al.	
	52	20060089708		2006-04-27	Osse et al.	
	53	20060111733		2006-05-25	Shriver	
	54	20060129225		2006-06-15	Kopia et al.	
	55	20060134079		2006-06-22	Sih et al.	
	56	20060140916		2006-06-29	Siani-Rose et al.	
	57	20060173475		2006-08-03	Lafontaine et al.	
	58	20060178740		2006-08-10	Stacchino et al.	
	59	20060190074		2006-08-24	Hill et al.	
	60	20060193885		2006-08-31	Neethling et al.	

<b>INFORMATION DISCLOSURE STATEMENT BY APPLICANT</b> ( Not for submission under 37 CFR 1.99)	Application Number		13675665	
	Filing Date		2012-11-13	
	First Named Inventor	David PANIAGUA		
	Art Unit	3738		
	Examiner Name	not assigned		
	Attorney Docket Number	109978.10101		

	61	20060195010		2006-08-31	Arnal et al.	
	62	20060195183		2006-08-31	Navia et al.	
	63	20060206203		2006-09-14	Yang et al.	
	64	20060229701		2006-10-12	Gurm et al.	
	65	20060240063		2006-10-26	Hunter et al.	
	66	20060240064		2006-10-26	Hunter et al.	
	67	20060259134		2006-11-16	Schwammenthal et al.	
	68	20060259135		2006-11-16	Navia et al.	
	69	20060259137		2006-11-16	Artof et al.	
	70	20060265056		2006-11-23	Nguyen et al.	
	71	20060287571		2006-12-21	Gozzi et al.	

<b>INFORMATION DISCLOSURE STATEMENT BY APPLICANT</b> ( Not for submission under 37 CFR 1.99)	Application Number		13675665	
	Filing Date		2012-11-13	
	First Named Inventor	David PANIAGUA		
	Art Unit		3738	
	Examiner Name	not assigned		
	Attorney Docket Number		109978.10101	

	72	20060292125		2006-12-28	Kellar et al.	
	73	20070010857		2007-01-11	Sugimoto et al.	
	74	20070043431		2007-02-22	Melsheimer	
	75	20070050014		2007-03-01	Johnson	
	76	20070050022		2007-03-01	Vidlund et al.	
	77	20070056346		2007-03-15	Spenser et al.	
	78	20070060932		2007-03-15	Stack et al.	
	79	20070100426		2007-05-03	Rudakov et al.	
	80	20070128174		2007-06-07	Kleinsek et al.	
	81	20070173861		2007-07-26	Strommer et al.	
	82	20070213813		2007-09-13	Von Segessler et al.	

<b>INFORMATION DISCLOSURE STATEMENT BY APPLICANT</b> ( Not for submission under 37 CFR 1.99)	Application Number		13675665	
	Filing Date		2012-11-13	
	First Named Inventor	David PANIAGUA		
	Art Unit		3738	
	Examiner Name	not assigned		
	Attorney Docket Number		109978.10101	

	83	20070250154		2007-10-25	Greenberg et al.	
	84	20070263226		2007-11-15	Kurtz et al.	
	85	20070276432		2007-11-29	Stack et al.	
	86	20080004686		2008-01-03	Hunt et al.	
	87	20080009667		2008-01-10	Longhini et al.	
	88	20080009940		2008-01-10	Cribier	
	89	20080029105		2008-02-07	Stevens et al.	
	90	20080039871		2008-02-14	Wallace et al.	
	91	20080039926		2008-02-14	Majercak et al.	
	92	20080058798		2008-03-06	Wallace et al.	
	93	20080082113		2008-04-03	Bishop et al.	

<b>INFORMATION DISCLOSURE STATEMENT BY APPLICANT</b> ( Not for submission under 37 CFR 1.99)	Application Number	13675665
	Filing Date	2012-11-13
	First Named Inventor	David PANIAGUA
	Art Unit	3738
	Examiner Name	not assigned
	Attorney Docket Number	109978.10101

	94	20080102439		2008-05-01	Tian et al.	
	95	20080133004		2008-06-05	White	
	96	20080147182		2008-06-19	Righini et al.	
	97	20080154356		2008-06-26	Obermiller et al.	
	98	20080177381		2008-07-24	Navia et al.	
	99	20080183280		2008-07-31	Agnew et al.	
	100	20080183283		2008-07-31	Downing	
	101	20080195200		2008-08-14	Vidlund et al.	
	102	20080190989		2008-08-14	Crews et al.	
	103	20080199843		2008-08-21	Haverich et al.	
	104	20080200977		2008-08-21	Paul et al.	

<b>INFORMATION DISCLOSURE STATEMENT BY APPLICANT</b> ( Not for submission under 37 CFR 1.99)	Application Number		13675665	
	Filing Date		2012-11-13	
	First Named Inventor	David PANIAGUA		
	Art Unit		3738	
	Examiner Name	not assigned		
	Attorney Docket Number		109978.10101	

	105	20090030511		2009-01-29	Paniagua et al.	
	106	20090043383		2009-02-12	McGregor et al.	
	107	20090062907		2009-03-05	Quijano et al.	
	108	20090112309		2009-04-30	Jaramillo et al.	
	109	20090132032		2009-09-15	Cribier	
	110	20090157175		2009-06-18	Benichou	
	111	20090164005		2009-06-25	Dove et al.	
	112	20090187241		2009-07-23	Melshemier	
	113	20090248149		2009-10-01	Gabbay	
	114	20090254175		2009-10-08	Quijano et al.	
	115	20090281609		2009-11-12	Benichou et al.	

<b>INFORMATION DISCLOSURE STATEMENT BY APPLICANT</b> ( Not for submission under 37 CFR 1.99)	Application Number	13675665
	Filing Date	2012-11-13
	First Named Inventor	David PANIAGUA
	Art Unit	3738
	Examiner Name	not assigned
	Attorney Docket Number	109978.10101

	116	20090030511		2009-01-29	Paniagua et al.	
	117	20100030259		2010-02-04	Pavcnik et al.	
	118	20100036479		2010-02-11	Hill et al.	
	119	20100036484		2010-02-11	Hariton et al.	
	120	20100048987		2010-02-25	Khairkhahan	
	121	20100049312		2010-02-25	Edoga et al.	
	122	20100131054		2010-05-27	Tuval et al.	
	123	20100161036		2010-06-24	Pintor et al.	
	124	20100185277		2010-07-22	Braido et al.	
	125	20100217382		2010-08-26	Chau et al.	
	126	20100234878		2010-09-16	Hruska	



<b>INFORMATION DISCLOSURE STATEMENT BY APPLICANT</b> ( Not for submission under 37 CFR 1.99)	Application Number		13675665	
	Filing Date		2012-11-13	
	First Named Inventor	David PANIAGUA		
	Art Unit	3738		
	Examiner Name	not assigned		
	Attorney Docket Number	109978.10101		

	127	20100249918		2010-09-30	Zhang	
	128	20100256749		2010-10-07	Tran et al.	
	129	20100256751		2010-10-07	Rowe et al.	
	130	20100312333		2010-12-09	Navia et al.	
	131	20110015728		2011-01-20	Jimenez et al.	
	132	20110040375		2010-02-17	Letac et al.	
	133	20110004299		2011-01-06	Navia et al.	
	134	20110087322		2011-04-14	Letac et al.	
	135	20110137409		2011-06-09	Yang et al.	
	136	20110146361		2011-06-23	Davidson et al.	
	137	20110153009		2011-06-23	Navia et al.	

<b>INFORMATION DISCLOSURE STATEMENT BY APPLICANT</b> ( Not for submission under 37 CFR 1.99)	Application Number		13675665	
	Filing Date		2012-11-13	
	First Named Inventor	David PANIAGUA		
	Art Unit		3738	
	Examiner Name	not assigned		
	Attorney Docket Number		109978.10101	

	138	20110166636		2011-07-07	Rowe	
	139	20110178597		2011-07-21	Navia et al.	
	140	20110218619		2011-09-08	Benichou et al.	
	141	20110224607		2011-09-15	Vogelbaum et al.	
	142	20110300625		2011-12-08	Paniagua et al.	
	143	20110301700		2011-12-08	Fish et al.	
	144	20120078343		2012-03-29	Fish	
	145	20120078356		2012-03-29	Fish et al.	
	146	20120095551		2012-04-19	Navia et al.	
	147	20120158128		2012-06-21	Gautam et al.	
	148	20120185038		2012-07-19	Fish et al.	

<b>INFORMATION DISCLOSURE STATEMENT BY APPLICANT</b> ( Not for submission under 37 CFR 1.99)	Application Number	13675665
	Filing Date	2012-11-13
	First Named Inventor	David PANIAGUA
	Art Unit	3738
	Examiner Name	not assigned
	Attorney Docket Number	109978.10101

	149	20120310041		2012-12-06	Paniagua et al.	
--	-----	-------------	--	------------	-----------------	--

If you wish to add additional U.S. Published Application citation information please click the Add button. **Add**

**FOREIGN PATENT DOCUMENTS**

Remove

Examiner Initial*	Cite No	Foreign Document Number <sup>3</sup>	Country Code <sup>2</sup> j	Kind Code <sup>4</sup>	Publication Date	Name of Patentee or Applicant of cited Document	Pages, Columns, Lines where Relevant Passages or Relevant Figures Appear	T <sup>5</sup>
	1							<input type="checkbox"/>

If you wish to add additional Foreign Patent Document citation information please click the Add button **Add**

**NON-PATENT LITERATURE DOCUMENTS**

Remove

Examiner Initials*	Cite No	Include name of the author (in CAPITAL LETTERS), title of the article (when appropriate), title of the item (book, magazine, journal, serial, symposium, catalog, etc), date, pages(s), volume-issue number(s), publisher, city and/or country where published.	T <sup>5</sup>
	1	PATHAK, CP et al., "Treatment of bioprosthetic heart valve tissue with long chain alcohol solution to lower calcification potential" J Biomed Mater Res A. 2004 Apr 1;69(1):140-4	<input type="checkbox"/>
	2	PAVENIK, Susan, M.D., PhD et al., "Development and Initial Experimental Evaluation of a Prosthetic Aortic Valve for Transcatherter Placement" Cardiovascular Radiology, April 1992, pp. 151-154	<input type="checkbox"/>
	3	PICK, Adam, "True or False: An Edwards Lifescience' Tissue Valve Replacement Requires 1,800 Hand-Sewn Stitches" <a href="http://heart-valve-surgery.com/heart-surgery-blog/2008/02/26">http://heart-valve-surgery.com/heart-surgery-blog/2008/02/26</a> . printed August 13, 2010	<input type="checkbox"/>
	4	POHL, M. et al., "In vitro testing of artificial heart valves; comparison between Newtonian and non-Newtonian fluids" Artif Orgns, Jan 1996; 20(1); pp. 37-46	<input type="checkbox"/>
	5	PURINYA, B. et al., "Biomechanical and Structural Properties of the Explanted Bioprosthetic Valve Leaflets" J. of Biomechanis, Vol 27, Iss 1, Jan 1994 Pages 1-11 Elsevier Science Ltd, 1993.	<input type="checkbox"/>

<b>INFORMATION DISCLOSURE STATEMENT BY APPLICANT ( Not for submission under 37 CFR 1.99)</b>	Application Number		13675665
	Filing Date		2012-11-13
	First Named Inventor	David PANIAGUA	
	Art Unit		3738
	Examiner Name	not assigned	
	Attorney Docket Number		109978.10101

6	SACKS, M S et al., "Collagen fiber architecture of bovine pericardium" ASAIO J, July 1, 1994, 40(3):M632-7	<input type="checkbox"/>
7	SACKS, M S et al., "A small angle light scattering device for planar connective tissue microstructural analysis" Ann Biomed Eng, July 1, 1997, 254(4); 678-89	<input type="checkbox"/>
8	SACKS, Michael S, "Incorporation of experimentally-derived fiber orientation into a structural constitutive model for planar collagenous tissues" J. Biomech Eng, April 1, 2003, 125(2); 280-7	<input type="checkbox"/>
9	SACKS, Michael S. et al., "Quantification of the fiber architecture and biaxial mechanical behavior of porcine intestinal submucosa" J of Biomedical Research, Vol 46, Iss 1, July 1999, pp 1-10	<input type="checkbox"/>
10	SAMOUILLAN, V. et al., " Comparison of chemical treatments on the chain dynamics and thermal stability of bovine pericardium collagen" J Biomed Mater Res A. 2003 Feb 1;64(2):330-8	<input type="checkbox"/>
11	SCHOEN, Frederick J., "Tissue heart valves: Current challenges and future research perspectives" J of Biomedical Materials Research, Vol 47, Iss 4, December 15, 1999, pp. 439-465	<input type="checkbox"/>
12	SELLARO, Tiffany L., "Effects of Collagen Orientation on the Medium-Term Fatigue Response of Heart Valve Biomaterials" 2003, (published thesis) pp. 40-45	<input type="checkbox"/>
13	SELLARO, Tiffany L. et al., "Effects of Collagen Fiber Orientation on the Response of Biologically Derived Soft Tissue Biomaterials to Cyclic Loading" J. Biomed Mater Res A 2007, Jan 01; 80(1): 194-205); published online Oct. 13, 2006 by Wiley InterScience	<input type="checkbox"/>
14	SHANDAS, Robin PhD et al., "A Method for Determining the Reference Effective Flow Areas for Mechanical Heart Valve Prostheses" Circulation April 25, 2000	<input type="checkbox"/>
15	SHEN, Ming et al., "Effect of ethanol and ether in the prevention of calcification of bioprostheses" Ann Thorac Surg. 2001 May;71(5 Suppl):S413-6	<input type="checkbox"/>
16	SHEN, Ming et al., "Protein adsorption in glutaraldehyde-preserved bovine pericardium and porcine valve tissues" The Annals of Thoracic Surgery, 2001; 71:409-409	<input type="checkbox"/>

<b>INFORMATION DISCLOSURE STATEMENT BY APPLICANT ( Not for submission under 37 CFR 1.99)</b>	Application Number		13675665
	Filing Date		2012-11-13
	First Named Inventor	David PANIAGUA	
	Art Unit	3738	
	Examiner Name	not assigned	
	Attorney Docket Number	109978.10101	

17	SIMIONESCU, D et al., "Mapping of glutaraldehyde-treated bovine pericardium and tissue selection for bioprosthetic heart valve" J. Biomed Mater Res, 1993, June 01:27(6):697-704	<input type="checkbox"/>
18	SUN, Wei et al., "Response of heterograft heart valve biomaterials to moderate cyclic loading" J Biomed Mater Res A, June 2004, 69(4); 658-69	<input type="checkbox"/>
19	TOPOL, Eric J., "Textbook of Interventional Cardiology", 1990, Chs. 43-44, pp. 831-867	<input type="checkbox"/>
20	VYAVAHARE, Narendra et al., "Mechanisms of bioprosthetic heart valve failure: Fatigue causes collagen denaturation and glycosaminoglysan loss" J of Biomedical Research, Vol 446, Iss 1, July 1999, pp 44-50	<input type="checkbox"/>
21	VYAVAHARE, NR et al., "Prevention of Glutaraldehyde-Fixed Bioprosthetic Heart Valve Calcification by Alcohol Pretreatment: Further Mechanistic Studies" J Heart Valve Dis. 2000 Jul;9(4):561-6	<input type="checkbox"/>
22	WIEGNER, A W et al., "Mechanical and structural correlates of canine pericardium" Circ Res, Sept 1, 1981m 49(3); 807-14	<input type="checkbox"/>
23	YASUI, Takeshi et al., "Determination of collagen fiber orientation in human tissue by use of polarization measurement of molecular second-harmonic-generation light", Applied Optics, Vol 42, No 14, May 10, 2004, pp. 2861-2867	<input type="checkbox"/>
24	ZIOUPOS, P. et al., "Anisotropic Elasticity and Strength of Glutaraldehyde Fixed Bovine Pericardium for Use in Pericardial Bioprosthetic Valves" J. Biomed Mater Res., 1994 Jan, 28(1):49-57	<input type="checkbox"/>
25	ZIOUPOS, P. et al., "Mechanical and Optical anisotropy of bovine pericardium" Med Biol Eng Comput, 1992 Jan; 30 (1); pp. 76-82	<input type="checkbox"/>
26	Office Action issued in U.S. Application 10/887,688, dated November 28, 2007 (54813-10100)	<input type="checkbox"/>
27	Final Office Action issued in U.S. Application 10/887,688, dated July 15, 2008 (54813-10100)	<input type="checkbox"/>

<b>INFORMATION DISCLOSURE STATEMENT BY APPLICANT ( Not for submission under 37 CFR 1.99)</b>	Application Number		13675665
	Filing Date		2012-11-13
	First Named Inventor	David PANIAGUA	
	Art Unit		3738
	Examiner Name	not assigned	
	Attorney Docket Number		109978.10101

28	Office Action issued in U.S. Application 10/887,688, dated March 16, 2009 (54813-10100)	<input type="checkbox"/>
29	Examiner Interview Summary issued in U.S. Application 10/887,688, dated June 12, 2009 (54813-10100)	<input type="checkbox"/>
30	Final Office Action issued in U.S. Application 10/887,688, dated March 2, 2010 (54813-10100)	<input type="checkbox"/>
31	Supplemental Declaration Under 37 CFR 1.131 by inventors filed in U.S. Application 10/887,688, filed September 14, 2009 (54813-10100)	<input type="checkbox"/>
32	Supplemental Declaration Under 37 CFR 1.131 by inventors filed in U.S. Application 10/887,688, filed February 28, 2008 (54813-10100)	<input type="checkbox"/>
33	Supplemental Declaration Under 37 CFR 1.131 by inventors filed in U.S. Application 10/887,688, filed December 15, 2008 (54813-10100)	<input type="checkbox"/>
34	Examiner Interview Summary issued in U.S. Application 10/887,688, dated July 26, 2010	<input type="checkbox"/>
35	Office Action issued in U.S. Application 10/887,688, dated February 16, 2012 (54813-10100)	<input type="checkbox"/>
36	Office Action issued September 29, 2010, issued in U.S. Application 12/228,192 (54813-10110)	<input type="checkbox"/>
37	Examiner Interview Summary, dated 04/05/2011 in U.S. Application No. 12/228,192 (54813-10110)	<input type="checkbox"/>
38	Final Office Action issued July 14, 2011, in U.S. Application No. 12/228,192 (54813-10110)	<input type="checkbox"/>

<b>INFORMATION DISCLOSURE STATEMENT BY APPLICANT</b> ( Not for submission under 37 CFR 1.99)	Application Number	13675665
	Filing Date	2012-11-13
	First Named Inventor	David PANIAGUA
	Art Unit	3738
	Examiner Name	not assigned
	Attorney Docket Number	109978.10101

39	Office Action issued in U.S. Application 10/037,266, dated May 8, 2003	<input type="checkbox"/>
40	Final Office Action issued in U.S. Application 10/037,266, dated March 9, 2004	<input type="checkbox"/>

If you wish to add additional non-patent literature document citation information please click the Add button **Add**

**EXAMINER SIGNATURE**

Examiner Signature		Date Considered	
--------------------	--	-----------------	--

\*EXAMINER: Initial if reference considered, whether or not citation is in conformance with MPEP 609. Draw line through a citation if not in conformance and not considered. Include copy of this form with next communication to applicant.

<sup>1</sup> See Kind Codes of USPTO Patent Documents at [www.USPTO.GOV](http://www.USPTO.GOV) or MPEP 901.04. <sup>2</sup> Enter office that issued the document, by the two-letter code (WIPO Standard ST.3). <sup>3</sup> For Japanese patent documents, the indication of the year of the reign of the Emperor must precede the serial number of the patent document. <sup>4</sup> Kind of document by the appropriate symbols as indicated on the document under WIPO Standard ST.16 if possible. <sup>5</sup> Applicant is to place a check mark here if English language translation is attached.

<b>INFORMATION DISCLOSURE STATEMENT BY APPLICANT</b> ( Not for submission under 37 CFR 1.99)	Application Number	13675665
	Filing Date	2012-11-13
	First Named Inventor	David PANIAGUA
	Art Unit	3738
	Examiner Name	not assigned
	Attorney Docket Number	109978.10101

**CERTIFICATION STATEMENT**

Please see 37 CFR 1.97 and 1.98 to make the appropriate selection(s):

That each item of information contained in the information disclosure statement was first cited in any communication from a foreign patent office in a counterpart foreign application not more than three months prior to the filing of the information disclosure statement. See 37 CFR 1.97(e)(1).

**OR**

That no item of information contained in the information disclosure statement was cited in a communication from a foreign patent office in a counterpart foreign application, and, to the knowledge of the person signing the certification after making reasonable inquiry, no item of information contained in the information disclosure statement was known to any individual designated in 37 CFR 1.56(c) more than three months prior to the filing of the information disclosure statement. See 37 CFR 1.97(e)(2).

See attached certification statement.

The fee set forth in 37 CFR 1.17 (p) has been submitted herewith.

A certification statement is not submitted herewith.

**SIGNATURE**

A signature of the applicant or representative is required in accordance with CFR 1.33, 10.18. Please see CFR 1.4(d) for the form of the signature.

Signature	/ Mark L. Yaskanin /	Date (YYYY-MM-DD)	2013-09-23
Name/Print	Mark L. Yaskanin	Registration Number	45246

This collection of information is required by 37 CFR 1.97 and 1.98. The information is required to obtain or retain a benefit by the public which is to file (and by the USPTO to process) an application. Confidentiality is governed by 35 U.S.C. 122 and 37 CFR 1.14. This collection is estimated to take 1 hour to complete, including gathering, preparing and submitting the completed application form to the USPTO. Time will vary depending upon the individual case. Any comments on the amount of time you require to complete this form and/or suggestions for reducing this burden, should be sent to the Chief Information Officer, U.S. Patent and Trademark Office, U.S. Department of Commerce, P.O. Box 1450, Alexandria, VA 22313-1450. **DO NOT SEND FEES OR COMPLETED FORMS TO THIS ADDRESS. SEND TO: Commissioner for Patents, P.O. Box 1450, Alexandria, VA 22313-1450.**



## Privacy Act Statement

The Privacy Act of 1974 (P.L. 93-579) requires that you be given certain information in connection with your submission of the attached form related to a patent application or patent. Accordingly, pursuant to the requirements of the Act, please be advised that: (1) the general authority for the collection of this information is 35 U.S.C. 2(b)(2); (2) furnishing of the information solicited is voluntary; and (3) the principal purpose for which the information is used by the U.S. Patent and Trademark Office is to process and/or examine your submission related to a patent application or patent. If you do not furnish the requested information, the U.S. Patent and Trademark Office may not be able to process and/or examine your submission, which may result in termination of proceedings or abandonment of the application or expiration of the patent.

The information provided by you in this form will be subject to the following routine uses:

1. The information on this form will be treated confidentially to the extent allowed under the Freedom of Information Act (5 U.S.C. 552) and the Privacy Act (5 U.S.C. 552a). Records from this system of records may be disclosed to the Department of Justice to determine whether the Freedom of Information Act requires disclosure of these records.
2. A record from this system of records may be disclosed, as a routine use, in the course of presenting evidence to a court, magistrate, or administrative tribunal, including disclosures to opposing counsel in the course of settlement negotiations.
3. A record in this system of records may be disclosed, as a routine use, to a Member of Congress submitting a request involving an individual, to whom the record pertains, when the individual has requested assistance from the Member with respect to the subject matter of the record.
4. A record in this system of records may be disclosed, as a routine use, to a contractor of the Agency having need for the information in order to perform a contract. Recipients of information shall be required to comply with the requirements of the Privacy Act of 1974, as amended, pursuant to 5 U.S.C. 552a(m).
5. A record related to an International Application filed under the Patent Cooperation Treaty in this system of records may be disclosed, as a routine use, to the International Bureau of the World Intellectual Property Organization, pursuant to the Patent Cooperation Treaty.
6. A record in this system of records may be disclosed, as a routine use, to another federal agency for purposes of National Security review (35 U.S.C. 181) and for review pursuant to the Atomic Energy Act (42 U.S.C. 218(c)).
7. A record from this system of records may be disclosed, as a routine use, to the Administrator, General Services, or his/her designee, during an inspection of records conducted by GSA as part of that agency's responsibility to recommend improvements in records management practices and programs, under authority of 44 U.S.C. 2904 and 2906. Such disclosure shall be made in accordance with the GSA regulations governing inspection of records for this purpose, and any other relevant (i.e., GSA or Commerce) directive. Such disclosure shall not be used to make determinations about individuals.
8. A record from this system of records may be disclosed, as a routine use, to the public after either publication of the application pursuant to 35 U.S.C. 122(b) or issuance of a patent pursuant to 35 U.S.C. 151. Further, a record may be disclosed, subject to the limitations of 37 CFR 1.14, as a routine use, to the public if the record was filed in an application which became abandoned or in which the proceedings were terminated and which application is referenced by either a published application, an application open to public inspections or an issued patent.
9. A record from this system of records may be disclosed, as a routine use, to a Federal, State, or local law enforcement agency, if the USPTO becomes aware of a violation or potential violation of law or regulation.

## Electronic Acknowledgement Receipt

<b>EFS ID:</b>	16896615
<b>Application Number:</b>	13675665
<b>International Application Number:</b>	
<b>Confirmation Number:</b>	1995
<b>Title of Invention:</b>	PERCUTANEOUSLY IMPLANTABLE REPLACEMENT HEART VALVE DEVICE AND METHOD OF MAKING SAME
<b>First Named Inventor/Applicant Name:</b>	David Paniagua
<b>Customer Number:</b>	29880
<b>Filer:</b>	Mark Lauren Yaskanin/Carol Donahue
<b>Filer Authorized By:</b>	Mark Lauren Yaskanin
<b>Attorney Docket Number:</b>	109978.10101
<b>Receipt Date:</b>	23-SEP-2013
<b>Filing Date:</b>	13-NOV-2012
<b>Time Stamp:</b>	16:27:29
<b>Application Type:</b>	Utility under 35 USC 111(a)

### Payment information:

Submitted with Payment	no
------------------------	----

### File Listing:

Document Number	Document Description	File Name	File Size(Bytes)/ Message Digest	Multi Part /.zip	Pages (if appl.)
1	Non Patent Literature	US_10-037266_Office_Action_2003-05-08.pdf	259047 914d4eb72f062d336803af5d89d99f82c7a41b0	no	7

### Warnings:

### Information:

2	Non Patent Literature	US_10-037266_Final_Office_Ac tion_2004-03-09.pdf	249887 3b61cf802da3c247d0aabdb2afe1ae201b5 b1ac5	no	7
<b>Warnings:</b>					
<b>Information:</b>					
3	Information Disclosure Statement (IDS) Form (SB08)	Colibri_10101_IDS_1.pdf	624035 53d32ef11fba26a36cb1a28a5e9262d4315 af4f	no	38
<b>Warnings:</b>					
<b>Information:</b>					
4	Information Disclosure Statement (IDS) Form (SB08)	Colibri_10101_IDS_2.pdf	618476 3b96922ac40a252b2f3f702bfd86929e41c1 d9fe	no	21
<b>Warnings:</b>					
<b>Information:</b>					
<b>Total Files Size (in bytes):</b>			1751445		
<p><b>This Acknowledgement Receipt evidences receipt on the noted date by the USPTO of the indicated documents, characterized by the applicant, and including page counts, where applicable. It serves as evidence of receipt similar to a Post Card, as described in MPEP 503.</b></p> <p><b><u>New Applications Under 35 U.S.C. 111</u></b>  If a new application is being filed and the application includes the necessary components for a filing date (see 37 CFR 1.53(b)-(d) and MPEP 506), a Filing Receipt (37 CFR 1.54) will be issued in due course and the date shown on this Acknowledgement Receipt will establish the filing date of the application.</p> <p><b><u>National Stage of an International Application under 35 U.S.C. 371</u></b>  If a timely submission to enter the national stage of an international application is compliant with the conditions of 35 U.S.C. 371 and other applicable requirements a Form PCT/DO/EO/903 indicating acceptance of the application as a national stage submission under 35 U.S.C. 371 will be issued in addition to the Filing Receipt, in due course.</p> <p><b><u>New International Application Filed with the USPTO as a Receiving Office</u></b>  If a new international application is being filed and the international application includes the necessary components for an international filing date (see PCT Article 11 and MPEP 1810), a Notification of the International Application Number and of the International Filing Date (Form PCT/RO/105) will be issued in due course, subject to prescriptions concerning national security, and the date shown on this Acknowledgement Receipt will establish the international filing date of the application.</p>					

<b>INFORMATION DISCLOSURE STATEMENT BY APPLICANT ( Not for submission under 37 CFR 1.99)</b>	Application Number		13675665
	Filing Date		2012-11-13
	First Named Inventor	David PANIAGUA	
	Art Unit	3738	
	Examiner Name	not assigned	
	Attorney Docket Number	109978.10101	

U.S. PATENTS						Remove
Examiner Initial*	Cite No	Patent Number	Kind Code <sup>1</sup>	Issue Date	Name of Patentee or Applicant of cited Document	Pages, Columns, Lines where Relevant Passages or Relevant Figures Appear
	1	RE40404		2008-06-24	Schmitt et al.	
	2	RE42395		2011-05-24	Wright et al.	
	3	3014024		1961-12-19	Lieberman et al.	
	4	3029819		1962-04-17	Edward	
	5	3105492		1963-10-01	Jeckel	
	6	3320972		1967-05-23	High et al.	
	7	3409914		1968-11-12	Jones	
	8	3548417		1970-12-22	Kischer et al.	

<b>INFORMATION DISCLOSURE STATEMENT BY APPLICANT</b> ( Not for submission under 37 CFR 1.99)	Application Number		13675665	
	Filing Date		2012-11-13	
	First Named Inventor	David PANIAGUA		
	Art Unit	3738		
	Examiner Name	not assigned		
	Attorney Docket Number	109978.10101		

	9	3562820		1971-02-16	Braun	
	10	3588920		1971-06-29	(Wesolowski	
	11	3671979		1972-06-27	Moulopoulos	
	12	3709175		1973-01-09	Edwards et al.	
	13	3878565		1975-04-22	Sauvage	
	14	3966401		1976-06-29	Hancock et al.	
	15	3945052		1976-03-23	Liebig	
	16	3983581		1976-10-05	Angell et al.	
	17	3986828		1976-10-19	Hoffman, Jr. et al.	
	18	4035849		1977-07-19	Angell et al.	
	19	4055861		1977-11-01	Carpentier et al.	

<b>INFORMATION DISCLOSURE STATEMENT BY APPLICANT</b> ( Not for submission under 37 CFR 1.99)	Application Number		13675665	
	Filing Date		2012-11-13	
	First Named Inventor	David PANIAGUA		
	Art Unit		3738	
	Examiner Name	not assigned		
	Attorney Docket Number		109978.10101	

	20	4056854		1977-11-08	Boretos et al.	
	21	4060081		1977-11-29	Yannas et al.	
	22	4082507		1978-04-04	Sawyer	
	23	4084268		1978-04-18	Ionescu et al.	
	24	4106129		1978-08-15	Carpentier et al.	
	25	4164045		1979-08-14	Bokros et al.	
	26	4172295		1979-10-30	Batten	
	27	4218782		1980-08-26	Rygg	
	28	4222126		1970-09-16	Boretos et al.	
	29	4233493		1980-11-11	Nath et al.	
	30	4265694		1981-05-05	Boretos et al.	

<b>INFORMATION DISCLOSURE STATEMENT BY APPLICANT</b> ( Not for submission under 37 CFR 1.99)	Application Number		13675665	
	Filing Date		2012-11-13	
	First Named Inventor	David PANIAGUA		
	Art Unit		3738	
	Examiner Name	not assigned		
	Attorney Docket Number		109978.10101	

	31	4291420		1981-09-29	Reul	
	32	4340977		1982-07-27	Brownlee et al.	
	33	4350492		1982-09-21	Wright et al.	
	34	4364127		1982-12-21	Pierce et al.	
	35	4388735		1983-06-21	Ionescu et al.	
	36	4423525		1984-01-03	Vallana et al.	
	37	4441216		1984-04-10	Ionescu et al.	
	38	4456589		1984-06-26	Holman et al.	
	39	4473423		1984-09-25	Kolff	
	40	4477930		1984-10-23	Totten et al.	
	41	4490859		1985-01-01	Black et al.	

<b>INFORMATION DISCLOSURE STATEMENT BY APPLICANT</b> ( Not for submission under 37 CFR 1.99)	Application Number		13675665	
	Filing Date		2012-11-13	
	First Named Inventor		David PANIAGUA	
	Art Unit		3738	
	Examiner Name		not assigned	
	Attorney Docket Number		109978.10101	

	42	4517687		1985-05-21	Liebig et al.	
	43	4545082		1985-10-08	Hood	
	44	4597762		1986-07-01	Walter et al.	
	45	4600533		1986-07-15	Chu	
	46	4631052		1986-12-23	Kensey	
	47	4666442		1987-05-19	Arru et al.	
	48	4728328		1998-03-01	Hughes et al.	
	49	4759758		1988-07-26	Gabbay	
	50	4759759		1988-07-26	Walker et al.	
	51	4798611		1989-01-17	Freeman, Jr.	
	52	4801299		1989-01-31	Brendel et al.	



<b>INFORMATION DISCLOSURE STATEMENT BY APPLICANT</b> ( Not for submission under 37 CFR 1.99)	Application Number	13675665
	Filing Date	2012-11-13
	First Named Inventor	David PANIAGUA
	Art Unit	3738
	Examiner Name	not assigned
	Attorney Docket Number	109978.10101

53	4870966		1989-10-03	Dellon et al.	
54	4883458		1989-11-28	Shiber	
55	4892539		1990-01-09	Koch	
56	4966604		1990-10-30	Reiss	
57	4976733		1990-12-11	Giradot	
58	4979939		1990-12-25	Shiber	
59	5006104		1991-04-09	Smith et al.	
60	5007896		1991-04-16	Shiber	
61	5011488		1991-04-30	Ginsburg	
62	5026366		1991-06-25	Leckrone	
63	5032128		1991-07-16	Alonso	

<b>INFORMATION DISCLOSURE STATEMENT BY APPLICANT</b> ( Not for submission under 37 CFR 1.99)	Application Number		13675665	
	Filing Date		2012-11-13	
	First Named Inventor	David PANIAGUA		
	Art Unit	3738		
	Examiner Name	not assigned		
	Attorney Docket Number	109978.10101		

	64	5047041		1991-09-10	Samuels	
	65	5047050		1991-09-10	Arpesani	
	66	5061277		1991-10-29	Carpentier et al.	
	67	5080660		1992-01-14	Buelna	
	68	5052771		1991-10-01	Williams et al.	
	69	5139515		1992-08-18	Robicsek	
	70	5163955		1992-11-17	Love et al.	
	71	5171273		1992-12-15	Silver et al.	
	72	5226889		1993-07-13	Sheiban	
	73	5261878		1993-11-16	Galindo	
	74	5282847		1994-02-01	Trescony et al.	

<b>INFORMATION DISCLOSURE STATEMENT BY APPLICANT</b> ( Not for submission under 37 CFR 1.99)	Application Number	13675665
	Filing Date	2012-11-13
	First Named Inventor	David PANIAGUA
	Art Unit	3738
	Examiner Name	not assigned
	Attorney Docket Number	109978.10101

	75	5326370		1994-07-05	Love et al.	
	76	5326371		1994-07-05	Love et al.	
	77	5332402		1994-07-26	Teitelbaum	
	78	5336616		1994-08-09	Livesey et al.	
	79	5360443		1994-11-01	Barone et al.	
	80	5374539		1994-12-20	Nimni et al.	
	81	5376110		1994-12-27	Tu et al.	
	82	5383927		1995-01-24	De Goiceochea et al.	
	83	5411552		1995-05-02	Anderson et al.	
	84	5413601		1995-05-09	Keshelava	
	85	5449384		1995-09-12	Johnson	

<b>INFORMATION DISCLOSURE STATEMENT BY APPLICANT</b> ( Not for submission under 37 CFR 1.99)	Application Number	13675665
	Filing Date	2012-11-13
	First Named Inventor	David PANIAGUA
	Art Unit	3738
	Examiner Name	not assigned
	Attorney Docket Number	109978.10101

86	5476506		1995-12-19	Lunn	
87	5480424		1996-01-02	Cox	
88	5489297		1996-02-06	Duran	
89	5500015		1996-03-19	Deac	
90	5509930		1996-04-23	Love	
91	5522879		1995-06-04	Scopelianos	
92	5522881		1996-06-04	Lentz	
93	5545215		1996-08-13	Duran	
94	5549664		1996-08-27	Hirata et al.	
95	5549666		1996-08-27	Hata et al.	
96	5571170		1996-11-05	Palmaz et al.	

<b>INFORMATION DISCLOSURE STATEMENT BY APPLICANT</b> ( Not for submission under 37 CFR 1.99)	Application Number		13675665	
	Filing Date		2012-11-13	
	First Named Inventor	David PANIAGUA		
	Art Unit		3738	
	Examiner Name	not assigned		
	Attorney Docket Number		109978.10101	

	97	5571173		1996-11-05	Parodi	
	98	5571174		1996-11-05	Love et al.	
	99	5578071		1996-11-26	Parodi	
	100	5578072		1996-11-26	Barone et al.	
	101	5582168		1996-12-10	Samuels et al.	
	102	5591229		1997-01-07	Parodi	
	103	5634928		1997-06-03	Fischell et al.	
	104	5653749		1997-08-05	Love et al.	
	105	5713953		1998-02-03	Vallana et al.	
	106	5728152		1998-03-17	Mirsch, II et al.	
	107	5733299		1998-03-21	Sheiban et al.	

<b>INFORMATION DISCLOSURE STATEMENT BY APPLICANT</b> ( Not for submission under 37 CFR 1.99)	Application Number		13675665	
	Filing Date		2012-11-13	
	First Named Inventor	David PANIAGUA		
	Art Unit	3738		
	Examiner Name	not assigned		
	Attorney Docket Number	109978.10101		

	108	5741333		1998-04-21	Frid	
	109	5746775		1998-05-05	Levy et al.	
	110	5769780		1998-06-23	Hata et al.	
	111	5782914		1998-07-21	Schankereel	
	112	5787887		1998-08-04	Klingenbeck-Regn	
	113	5840081		1998-11-24	Anderson et al.	
	114	5855601		1999-01-05	Bessler et al.	
	115	5861028		1999-01-19	Angell	
	116	5862806		1999-01-26	Cheung	
	117	5895420		1999-04-20	Mirsch, II et al.	
	118	5931969		1999-08-03	Carpentier et al.	

<b>INFORMATION DISCLOSURE STATEMENT BY APPLICANT</b> ( Not for submission under 37 CFR 1.99)	Application Number		13675665	
	Filing Date		2012-11-13	
	First Named Inventor	David PANIAGUA		
	Art Unit		3738	
	Examiner Name	not assigned		
	Attorney Docket Number		109978.10101	

	119	5957949		1999-09-28	Leonhardt et al.	
	120	5961539		1999-10-05	Northup et al.	
	121	5961549		1999-10-05	Nguyen et al.	
	122	5972030		1999-10-26	Garrison et al.	
	123	5976179		1999-11-02	Inoue	
	124	6004328		1999-12-21	Solar	
	125	6004330		1999-12-21	Middleman et al.	
	126	6010531		2000-01-04	Donlon et al.	
	127	6029671		2000-02-29	Stevens et al.	
	128	6045576		2000-04-04	Starr et al.	
	129	6053938		2000-04-25	Goldmann et al.	

<b>INFORMATION DISCLOSURE STATEMENT BY APPLICANT</b> ( Not for submission under 37 CFR 1.99)	Application Number	13675665
	Filing Date	2012-11-13
	First Named Inventor	David PANIAGUA
	Art Unit	3738
	Examiner Name	not assigned
	Attorney Docket Number	109978.10101

	130	6091984		2000-07-18	Perelman et al.	
	131	6102944		2000-08-15	Huynh et al.	
	132	6117169		2000-09-12	Moe	
	133	6125852		2000-10-03	Stevens et al.	
	134	6126686		2000-10-03	Badylak et al.	
	135	6129756		2000-10-10	Kugler	
	136	6162245		2000-12-19	Jayaraman	
	137	6168614		2001-01-02	Andersen et al.	
	138	6168619		2001-01-02	Dinh et al.	
	139	6171335		2001-01-09	Wheatley et al.	
	140	6174327		2001-01-16	Mertens et al.	



<b>INFORMATION DISCLOSURE STATEMENT BY APPLICANT</b> ( Not for submission under 37 CFR 1.99)	Application Number		13675665	
	Filing Date		2012-11-13	
	First Named Inventor	David PANIAGUA		
	Art Unit		3738	
	Examiner Name	not assigned		
	Attorney Docket Number		109978.10101	

	141	6186999		2001-02-13	Chen	
	142	6197143		2001-03-06	Bodnar	
	143	6214055		2001-04-10	Simionescu et al.	
	144	6221091		2001-04-24	Khosravi	
	145	6231602		2001-05-15	Carpentier et al.	
	146	6254629		2001-07-03	Inoue	
	147	6254630		2001-07-03	Inoue	
	148	6254636		2001-07-03	Peredo	
	149	6264691		2001-07-24	Gabbay	
	150	6269819		2001-08-07	Oz et al.	
	151	6270526		2001-08-07	Cox	

<b>INFORMATION DISCLOSURE STATEMENT BY APPLICANT</b> ( Not for submission under 37 CFR 1.99)	Application Number	13675665
	Filing Date	2012-11-13
	First Named Inventor	David PANIAGUA
	Art Unit	3738
	Examiner Name	not assigned
	Attorney Docket Number	109978.10101

	152	6277397		2001-08-21	Shimizu	
	153	6277555		2001-08-21	Duran et al.	
	154	6287335		2001-09-11	Drasler et al.	
	155	6293970		2001-09-25	Wolfenbarger, Jr. et al.	
	156	6312462		2001-11-06	McDermott et al.	
	157	6312474		2001-11-06	Francis et al.	
	158	6334873		2002-01-01	Lane et al.	
	159	6342069		2002-01-29	Deac et al.	
	160	6350282		2002-02-26	Eberhardt	
	161	6352554		2002-03-05	De Paulis	
	162	6352708		2002-03-05	Duran et al.	

<b>INFORMATION DISCLOSURE STATEMENT BY APPLICANT</b> ( Not for submission under 37 CFR 1.99)	Application Number		13675665	
	Filing Date		2012-11-13	
	First Named Inventor	David PANIAGUA		
	Art Unit		3738	
	Examiner Name	not assigned		
	Attorney Docket Number		109978.10101	

	163	6358275		2002-03-19	McIlroy et al.	
	164	6358284		2002-03-19	Fearnot et al.	
	165	6371980		2002-04-16	Rudakov et al.	
	166	6376244		2002-04-23	Atala et al.	
	167	6378221		2002-04-30	Ekholm, Jr. et al.	
	168	6383171		2002-05-07	Gifford et al.	
	169	6391333		2002-05-21	Li et al.	
	170	6409755		2002-06-25	Vrba	
	171	6418339		2002-07-09	Essenpreis et al.	
	172	6425916		2002-07-30	Garrison et al.	
	173	6432712		2002-08-13	Wolfenbarger, Jr. et al.	

<b>INFORMATION DISCLOSURE STATEMENT BY APPLICANT</b> ( Not for submission under 37 CFR 1.99)	Application Number	13675665
	Filing Date	2012-11-13
	First Named Inventor	David PANIAGUA
	Art Unit	3738
	Examiner Name	not assigned
	Attorney Docket Number	109978.10101

	174	6440167		2002-08-27	Shimizu	
	175	6458153		2002-10-01	Bailey et al.	
	176	6461382		2002-10-08	Cao	
	177	6468313		2002-10-22	Claeson et al.	
	178	6471723		2002-10-29	Ashworth et al.	
	179	6482227		2002-11-19	Solovay	
	180	6482228		2002-11-19	Norred	
	181	6482240		2002-11-19	Echmayer et al.	
	182	6491719		2002-12-10	Fogarty et al.	
	183	6494909		2002-12-17	Greenhalgh	
	184	6503272		2003-01-07	Duerig et al.	

<b>INFORMATION DISCLOSURE STATEMENT BY APPLICANT</b> ( Not for submission under 37 CFR 1.99)	Application Number		13675665	
	Filing Date		2012-11-13	
	First Named Inventor	David PANIAGUA		
	Art Unit		3738	
	Examiner Name	not assigned		
	Attorney Docket Number		109978.10101	

	185	6534004		2003-03-18	Chen et al.	
	186	6558418		2003-05-06	Carpentier et al.	
	187	6569200		2003-05-27	Wolfenbarger Jr. et al.	
	188	6565960		2003-05-20	Koob et al.	
	189	6582458		2003-06-24	White et al.	
	190	6582462		2003-06-24	Andersen et al.	
	191	6582464		2003-06-24	Gabbay	
	192	6599524		2003-07-29	Li et al.	
	193	6624890		2003-09-23	Backman et al.	
	194	6626938		2003-09-30	Butaric et al.	
	195	6652577		2003-11-25	Gianotti	

<b>INFORMATION DISCLOSURE STATEMENT BY APPLICANT</b> ( Not for submission under 37 CFR 1.99)	Application Number		13675665	
	Filing Date		2012-11-13	
	First Named Inventor	David PANIAGUA		
	Art Unit		3738	
	Examiner Name	not assigned		
	Attorney Docket Number		109978.10101	

	196	6652578		2003-11-25	Bailey et al.	
	197	6553681		2003-04-29	Ekholm, Jr. et al.	
	198	6610088		2003-08-26	Gabbay	
	199	6666886		2003-12-23	Tranquillo et al.	
	200	6682559		2004-01-27	Myers et al.	
	201	6685739		2004-02-03	Dimatteo et al.	
	202	6696074		2004-02-24	Dia et al.	
	203	6719788		2004-04-13	Cox	
	204	6719789		2004-04-13	Cox	
	205	6702826		2004-03-09	Liddicoat et al.	
	206	6736823		2004-05-18	Darios et al.	

<b>INFORMATION DISCLOSURE STATEMENT BY APPLICANT</b> ( Not for submission under 37 CFR 1.99)	Application Number		13675665	
	Filing Date		2012-11-13	
	First Named Inventor	David PANIAGUA		
	Art Unit	3738		
	Examiner Name	not assigned		
	Attorney Docket Number	109978.10101		

	207	6764510		2004-07-20	Vidlund et al.	
	208	6773456		2004-08-10	Gordon et al.	
	209	6773457		2004-08-10	Ivancev	
	210	6790229		2004-09-14	Berreklouw	
	211	6792979		2004-09-21	Konya et al.	
	212	6802319		2004-10-12	Stevens et al.	
	213	6802806		2004-10-12	McCarthy et al.	
	214	6821530		2004-11-23	Koob et al.	
	215	6893460		2005-05-17	Spenser et al.	
	216	6908481		2005-06-21	Cribier	
	217	6913608		2005-07-02	Liddicoat et al.	

<b>INFORMATION DISCLOSURE STATEMENT BY APPLICANT</b> ( Not for submission under 37 CFR 1.99)	Application Number		13675665	
	Filing Date		2012-11-13	
	First Named Inventor	David PANIAGUA		
	Art Unit	3738		
	Examiner Name	not assigned		
	Attorney Docket Number	109978.10101		

	218	6916338		2005-07-12	Speziali	
	219	6942694		2005-09-13	Liddicoat et al.	
	220	6951571		2005-10-04	Srivastava	
	221	6961123		2005-11-01	Wang et al.	
	222	6977231		2005-12-20	Matsuda	
	223	6986735		2006-01-17	Abraham et al.	
	224	7004925		2006-02-28	Navia et al.	
	225	7008763		2006-03-07	Cheung	
	226	7011688		2006-03-14	Gryska et al.	
	227	7018404		2006-03-28	Holmberg et al.	
	228	7022348		2006-04-04	Ketharananthan	



<b>INFORMATION DISCLOSURE STATEMENT BY APPLICANT</b> ( Not for submission under 37 CFR 1.99)	Application Number	13675665
	Filing Date	2012-11-13
	First Named Inventor	David PANIAGUA
	Art Unit	3738
	Examiner Name	not assigned
	Attorney Docket Number	109978.10101

	229	7025780		2006-04-11	Gabbay	
	230	7037333		2006-05-02	Myers et al.	
	231	7039446		2006-05-02	Ruchti et al.	
	232	7041132		2006-05-09	Quijano et al.	
	233	7053051		2006-05-30	Hendriks et al.	
	234	7060092		2006-06-13	Kuribayashi et al.	
	235	7070616		2006-07-04	Majercak et al.	
	236	7077862		2006-07-18	Vidlund et al.	
	237	7084082		2006-08-01	Shimizu	
	238	7138226		2006-11-21	Vincek et al.	
	239	7153324		2006-12-26	Case et al.	

<b>INFORMATION DISCLOSURE STATEMENT BY APPLICANT</b> ( Not for submission under 37 CFR 1.99)	Application Number	13675665
	Filing Date	2012-11-13
	First Named Inventor	David PANIAGUA
	Art Unit	3738
	Examiner Name	not assigned
	Attorney Docket Number	109978.10101

	240	7160322		2007-01-09	Gabbay	
	241	7164145		2007-01-16	Shakespeare	
	242	7166570		2007-01-23	Hunter et al.	
	243	7189259		2007-03-13	Simionescu et al.	
	244	7213601		2007-05-08	Stevens et al.	
	245	7214242		2007-05-08	Abraham et al.	
	246	7232461		2007-06-19	Ramer	
	247	7261732		2007-08-28	Justino	
	248	7289211		2007-10-30	Walsh, Jr. et al.	
	249	7309461		2007-12-18	Kujawski et al.	
	250	7311730		2007-12-25	Gabbay	

<b>INFORMATION DISCLOSURE STATEMENT BY APPLICANT</b> ( Not for submission under 37 CFR 1.99)	Application Number		13675665	
	Filing Date		2012-11-13	
	First Named Inventor	David PANIAGUA		
	Art Unit	3738		
	Examiner Name	not assigned		
	Attorney Docket Number	109978.10101		

	251	7318998		2008-01-15	Goldstein et al.	
	252	7331993		2008-02-19	White	
	253	7329279		2008-02-12	Haug et al.	
	254	7354702		2008-04-08	Dai et al.	
	255	7381218		2008-06-03	Schreck	
	256	7381219		2008-06-03	Salahieh et al.	
	257	7399315		2008-07-15	lobbi	
	258	7427291		2008-09-23	Liddicoat e al.	
	259	7431725		2008-10-07	Stack et al.	
	260	7468073		2008-12-23	Johnson et al.	
	261	7473237		2009-01-06	Navia et al.	

<b>INFORMATION DISCLOSURE STATEMENT BY APPLICANT</b> ( Not for submission under 37 CFR 1.99)	Application Number		13675665	
	Filing Date		2012-11-13	
	First Named Inventor	David PANIAGUA		
	Art Unit		3738	
	Examiner Name	not assigned		
	Attorney Docket Number		109978.10101	

	262	7481838		2009-01-27	Carpentier et al.	
	263	7503929		2009-03-17	Johnson et al.	
	264	7510571		2009-03-31	Spiridigliozi et al.	
	265	7510575		2009-03-31	Spenser et al.	
	266	7524330		2009-04-28	Berrekouw	
	267	7566343		2009-07-28	Jenson et al.	
	268	7585321		2009-09-08	Cribier	
	269	7604661		2009-10-20	Pavcnik et al.	
	270	7618446		2009-11-17	Andersen et al.	
	271	7622276		2009-11-24	Cunanan et al.	
	272	7628805		2009-12-08	Spenser et al.	

<b>INFORMATION DISCLOSURE STATEMENT BY APPLICANT</b> ( Not for submission under 37 CFR 1.99)	Application Number		13675665	
	Filing Date		2012-11-13	
	First Named Inventor	David PANIAGUA		
	Art Unit	3738		
	Examiner Name	not assigned		
	Attorney Docket Number	109978.10101		

	273	7648676		2010-01-19	Mills et al.	
	274	7670368		2010-03-02	Hill et al.	
	275	7708775		2010-05-04	Rowe et al.	
	276	7758632		2010-07-20	Hojeibane et al.	
	277	7780722		2010-08-24	Thielen et al.	
	278	7789909		2010-09-07	Andersen et al.	
	279	7846203		2010-12-07	Cribier	
	280	7846204		2010-12-07	Letac et al.	
	281	7871431		2011-01-18	Gurm et al.	
	282	7892281		2011-02-22	Sequin et al.	
	283	7914576		2011-03-29	Navia et al.	

<b>INFORMATION DISCLOSURE STATEMENT BY APPLICANT</b> ( Not for submission under 37 CFR 1.99)	Application Number	13675665
	Filing Date	2012-11-13
	First Named Inventor	David PANIAGUA
	Art Unit	3738
	Examiner Name	not assigned
	Attorney Docket Number	109978.10101

	284	7967833		2011-06-28	Sterman et al.	
	285	7981151		2011-07-19	Rowe	
	286	8002825		2011-08-23	Letac et al.	
	287	8007992		2011-08-30	Tian et al.	
	288	8057540		2011-11-15	Letac et al.	
	289	8080054		2011-12-20	Rowe	
	290	8105375		2012-01-31	Navia et al.	

If you wish to add additional U.S. Patent citation information please click the Add button. [Add](#)

**U.S. PATENT APPLICATION PUBLICATIONS** [Remove](#)

Examiner Initial*	Cite No	Publication Number	Kind Code <sup>1</sup>	Publication Date	Name of Patentee or Applicant of cited Document	Pages, Columns, Lines where Relevant Passages or Relevant Figures Appear
	1	20010010017		2001-07-26	Letac et al.	
	2	20010049558		2001-12-06	Liddicoat et al.	

<b>INFORMATION DISCLOSURE STATEMENT BY APPLICANT ( Not for submission under 37 CFR 1.99)</b>	Application Number		13675665	
	Filing Date		2012-11-13	
	First Named Inventor	David PANIAGUA		
	Art Unit	3738		
	Examiner Name	not assigned		
	Attorney Docket Number	109978.10101		

	3	20010023372		2001-09-20	Chen et al.	
	4	20020005073		2002-01-17	Tompkins et al.	
	5	20020028243		2002-03-07	Masters	
	6	20020029783		2002-03-14	Stevens et al.	
	7	20020037940		2002-03-28	Koob et al.	
	8	20020042621		2002-04-11	Liddicoat et al.	
	9	20020091441		2002-07-11	Guzik	
	10	20020095167		2002-07-18	Liddicoat et al.	

If you wish to add additional U.S. Published Application citation information please click the Add button. [Add](#)

FOREIGN PATENT DOCUMENTS								Remove
Examiner Initial*	Cite No	Foreign Document Number <sup>3</sup>	Country Code <sup>2</sup> j	Kind Code <sup>4</sup>	Publication Date	Name of Patentee or Applicant of cited Document	Pages, Columns, Lines where Relevant Passages or Relevant Figures Appear	T <sup>5</sup>
	1	1441672	EP		2011-09-14	Edwards Lifesciences PVT, Inc.		<input type="checkbox"/>

<b>INFORMATION DISCLOSURE STATEMENT BY APPLICANT</b> ( Not for submission under 37 CFR 1.99)	Application Number		13675665	
	Filing Date		2012-11-13	
	First Named Inventor	David PANIAGUA		
	Art Unit	3738		
	Examiner Name	not assigned		
	Attorney Docket Number	109978.10101		

	2	1603493	EP		2005-12-14	Edwards Lifesciences Corp.		<input type="checkbox"/>
	3	1621162	EP		2012-05-30	Edwards Lifesciences PVT, Inc.		<input type="checkbox"/>
	4	2000115	EP		2011-05-04	Edwards Lifesciences PVT, Inc		<input type="checkbox"/>
	5	2055266	EP		2012-02-15	Edwards Lifesciences PVT, Inc		<input type="checkbox"/>
	6	2260796	EP		2013-02-20	Edwards Lifesciences PVT, Inc		<input type="checkbox"/>
	7	2355361C	RU		2009-05-20	Zhuravleva Irina Jur Evna		<input type="checkbox"/>
	8	1991/017720	WO		1991-11-28	Andersen et al.		<input type="checkbox"/>
	9	1992/017118	WO		1992-10-15	Shturman Cardiology Systems, Inc.		<input type="checkbox"/>
	10	1998/029057	WO		1998-07-09	Cordis Corporation		<input type="checkbox"/>
	11	1999/30646	WO		1999-06-24	St. Jude Medical, Inc.		<input type="checkbox"/>
	12	2000/012164	WO		2000-03-09	The Cleveland Clinic Foundation		<input type="checkbox"/>



<b>INFORMATION DISCLOSURE STATEMENT BY APPLICANT</b> ( Not for submission under 37 CFR 1.99)	Application Number		13675665	
	Filing Date		2012-11-13	
	First Named Inventor	David PANIAGUA		
	Art Unit	3738		
	Examiner Name	not assigned		
	Attorney Docket Number	109978.10101		

	13	2001/002031	WO		2001-01-11	Biomedical Design, Inc.		<input type="checkbox"/>
	14	2003/047468	WO		2003-06-12	Percutaneous Valve Technologies		<input type="checkbox"/>
	15	2003/092554	WO		2003-11-13	The General Hospital Corporation		<input type="checkbox"/>
	16	2004/026124	WO		2004-04-01	The Cleveland Clinic Foundation		<input type="checkbox"/>
	17	2008/082527	WO		2008-07-10	Edwards Lifesciences Corp.		<input type="checkbox"/>
	18	2006/095342	WO		2006-09-14	Technion Research & Development Foundation Ltd.		<input type="checkbox"/>
	19	2007/138572	WO		2007-12-06	Mor Research Applications Ltd.		<input type="checkbox"/>
	20	2008/063537	WO		2008-08-14	St. Jude Medical, Inc.		<input type="checkbox"/>
	21	2008/106531	WO		2008-09-04	Edwards Lifesciences Corp.		<input type="checkbox"/>
	22	2009/156471	WO		2009-12-30	Iberhospitex, S.A.		<input type="checkbox"/>
	23	2009/052188	WO		2009-04-23	Edwards Lifesciences Corporation		<input type="checkbox"/>

<b>INFORMATION DISCLOSURE STATEMENT BY APPLICANT ( Not for submission under 37 CFR 1.99)</b>	Application Number		13675665	
	Filing Date		2012-11-13	
	First Named Inventor	David PANIAGUA		
	Art Unit	3738		
	Examiner Name	not assigned		
	Attorney Docket Number	109978.10101		

	24	2010/024801	WO		2010-03-04	Cardiokinetix, Inc.		<input type="checkbox"/>
	25	2010/027363	WO		2010-03-11	Merlin PTE Ltd.		<input type="checkbox"/>
	26	2010/080594	WO		2010-07-15	Edwards Lifesciences Corp.		<input type="checkbox"/>
	27	2010/117541	WO		2010-10-14	Medtronic Vascular Inc.		<input type="checkbox"/>
	28	2011/109433	WO		2011-03-01	Paniagua et al.		<input type="checkbox"/>
	29	2011/109450	WO		2011-09-09	Colibri Heart Valve LLC		<input type="checkbox"/>
	30	2012/006124	WO		2012-01-12	Fish		<input type="checkbox"/>
	31	2012/040643	WO		2012-03-29	Fish et al.		<input type="checkbox"/>
	32	2012/082952	WO		2012-06-21	Fish et al.		<input type="checkbox"/>

If you wish to add additional Foreign Patent Document citation information please click the Add button								Add
<b>NON-PATENT LITERATURE DOCUMENTS</b>								Remove
Examiner Initials*	Cite No	Include name of the author (in CAPITAL LETTERS), title of the article (when appropriate), title of the item (book, magazine, journal, serial, symposium, catalog, etc), date, pages(s), volume-issue number(s), publisher, city and/or country where published.						T5

<b>INFORMATION DISCLOSURE STATEMENT BY APPLICANT ( Not for submission under 37 CFR 1.99)</b>	Application Number	13675665
	Filing Date	2012-11-13
	First Named Inventor	David PANIAGUA
	Art Unit	3738
	Examiner Name	not assigned
	Attorney Docket Number	109978.10101

1	Affidavit of Dr. Paolo Angelini, M.D., signed August 25, 2009	<input type="checkbox"/>
2	Affidavit of Dr. Gervasio A. Lamas, M.D., signed September 3, 2009	<input type="checkbox"/>
3	ANDERSEN, H.R. et al., "Transluminal implantation of artificial heart valve" European Heart Journal, 1992, 13, pp. 704-708	<input type="checkbox"/>
4	"Artificial heart valve" <a href="http://en.wikipedia.org/Artificial_heart_valve">http://en.wikipedia.org/Artificial_heart_valve</a> , printed May 13, 2009	<input type="checkbox"/>
5	BONHOEFFER, Philipp M.D. et al., "Percutaneous Insertion of the Pulmonary Valve" J of the Amer College of Cardiology, Vol 39, No 10, Elsevier Science, Inc. 2002, pp 1664-1669, London, UK, and Paris, FR	<input type="checkbox"/>
6	BONHOEFFER, Philipp et al., "Percutaneous replacement of pulmonary valve in a right-ventricle to pulmonary-artery prosthetic conduit with valve dysfunction" Early Report, The Lancet, Vol 356, October 21, 2000, p. 1403-1405	<input type="checkbox"/>
7	BONHOEFFER, Philipp et al., "Transcatheter Implantation of a Bovine Valve in Pulmonary Position: A Lamb Study" Circulation J. of the Amer Heart Assoc, 2000; 102; 813-816	<input type="checkbox"/>
8	BOUDJEMLINE, Younes et al., "Percutaneous pulmonary valve replacement in a large right ventricular outflow tract: An experimental study" J. Am. Coll. Cardiol. 2004; 43; 1082-1087	<input type="checkbox"/>
9	BRAGA-VILELA, A. et al., "Extracellular Matrix of Porcine Pericardium; Biochemistry and Collagen Architecture" J. Membr Biol., 2008	<input type="checkbox"/>
10	BREUER, Christopher K. M.D. et al., "Application of Tissue-Engineering Principles toward the Development of a Semilunar Heart Valve Substitute" Tissue Engineering, Vol 10, No. 11/12, 2004 pp. 1725-1736	<input type="checkbox"/>
11	CALE, A.R. et al., "Revisited: a descending thoracic aortic valve to treat prosthetic valve insufficiency" Ann Thorac Surg, May 1993, 55(5), pp. 1218-2	<input type="checkbox"/>

<b>INFORMATION DISCLOSURE STATEMENT BY APPLICANT</b> ( Not for submission under 37 CFR 1.99)	Application Number	13675665
	Filing Date	2012-11-13
	First Named Inventor	David PANIAGUA
	Art Unit	3738
	Examiner Name	not assigned
	Attorney Docket Number	109978.10101

12	CERROLAZA, M et al., "A comparison of the hydrodynamical behaviour of three heart aortic prostheses by numerical methods"	<input type="checkbox"/>
13	CHEW, G.G. et al., Abstract for "Simulation of Damage in a Porcine Prosthetic Heart Valve" J. Med. Eng. Technol., 1999 Sep-Oct; 23(5): 178-89	<input type="checkbox"/>
14	CHRISTIE G.W. et al., Abstract for "On Stress Reduction in Bioprosthetic Heart Valve Leaflets by the Use of a Flexible Stent" J. Card Surg, 1991 Dec; 6(4) pp. 476-81	<input type="checkbox"/>
15	"Collagen" <a href="http://en.wikipedia.org/wiki/Collagen">http://en.wikipedia.org/wiki/Collagen</a> , printed May 13, 2009	<input type="checkbox"/>
16	COLLINS, J. J., Jr, "The Evolution of artificial heart valve" N. Engl J Med, 1991 Feb 28; 324(9):624-6	<input type="checkbox"/>
17	CORDEN, J. et al., "The influence of open leaflet geometry on the haemodynamic flow characteristics of polyurethane trileaflet artificial heart valve" PubMed medline query, page 1 of 1	<input type="checkbox"/>
18	CRIBIER, Alain et al., "Percutaneous Transcatheter Implantation of an Aortic Valve Prosthesis for Calcific Aortic Stenosis: First Human Case Description" Circulation J of the Amer Heart Assoc, originally published online Nov 25, 2002	<input type="checkbox"/>
19	Edwards Lifesciences Receives FDA Approval for New Heart Valve, <a href="http://www.medicalnewstoday.com/articles/149588.php">http://www.medicalnewstoday.com/articles/149588.php</a> , May 11, 2009	<input type="checkbox"/>
20	FISH, R. David, "Percutaneous Heart Valve Replacement: Enthusiasm Tempered" Circulation J of the Amer Heart Assoc, 2004; 110; 1876-1878	<input type="checkbox"/>
21	FISHBEIN, M.C. et al., "Cardiac pathology after aortic valve replacement using Hufnagel trileaflet prostheses: study of 20 necropsy patients" Ann Heart J., April 1975, 89(4), pp. 443-448	<input type="checkbox"/>
22	GLOECKNER, D. Claire et al., "Mechanical Evaluation and Design of a Multilayered Collagenous Repair Biomaterial" J. of Biomedical Materials Research Part A, Vol. 52 Iss 2, PP 365-373, Published online Aug. 15, 2000, Wiley Periodicals, Inc.	<input type="checkbox"/>

<b>INFORMATION DISCLOSURE STATEMENT BY APPLICANT ( Not for submission under 37 CFR 1.99)</b>	Application Number		13675665
	Filing Date		2012-11-13
	First Named Inventor	David PANIAGUA	
	Art Unit		3738
	Examiner Name	not assigned	
	Attorney Docket Number		109978.10101

23	Grube E., et al., Abstract for "Progress and Current Status of Percutaneous Aortic Valve Replacement: Results of Three Device Generations of the CoreValve Revalving System", Circ. Cardiovasc Intervent. 2008;1:167-175	<input type="checkbox"/>
24	HANLON, JG et al., "Pre-use intraoperative testing of autologous tissue for valvular surgery: a proof of concept study" J. Heart Valve Dis, Nov 1999; 8(6); pp. 614-23	<input type="checkbox"/>
25	BECH-HANSEN, Odd, M.D. et al., "Aortic Prosthetic Valve Desing and Size: Relation to Doppler Echocardiographic Finding and Pressure Recovery --- An In Vitro Study" J. Am Soc Echocardiography 2000; 13:39-50	<input type="checkbox"/>
26	HASENKAM, J.M. et al., "A model for acute haemodynamic studies in the ascending aorta in pigs" Cardiovasc Res, July 1988, 22(7), pp. 464-71	<input type="checkbox"/>
27	HIESTER, E.D. et al., "Optimal bovine pericardial tissue selection sites. I. Fiber architecture and tissue thickness measurements." J. Biomed Mater Res, 1998, Feb, 01; 39(2):207-14	<input type="checkbox"/>
28	HUFNAGEL, Charles A., M.D., "Basic Concepts in the Development of Cardiovascular Prostheses" The American Journal of Surgery, Vol 137, March 1979	<input type="checkbox"/>
29	HUFNAGEL, Charles.A., MD et al., "In the beginning. Surgical Correction of Aortic Insufficiency" 1954; Ann Thorac Surg 1989 May; 47(3), pp. 475-476	<input type="checkbox"/>
30	HUFNAGEL, Charles.A., MD et al., "Late follow-up of ball-valve prostheses in the descending thoracic aortia", J. Thorac Cardiovasc Surg, December 1976, 72(6), pp. 900-909	<input type="checkbox"/>
31	HUFNAGEL, Charles.A., MD et al., "Surgical Correction of Aortic Insufficiency" Surgery Vol 35, May, 1954 No. 5	<input type="checkbox"/>
32	HUFNAGEL, Charles A., "Vessels and Valves", Sec. 1: Development of Cardiac Surgery, Chap 7, pp. 43-55	<input type="checkbox"/>
33	Introduction to Stereomicroscopy, <a href="http://www.microscopyu.com/articles/stereomicroscopy/stereointro.html">http://www.microscopyu.com/articles/stereomicroscopy/stereointro.html</a> , Copyrigh 2000-2012, printed on March 15, 2012	<input type="checkbox"/>

<b>INFORMATION DISCLOSURE STATEMENT BY APPLICANT ( Not for submission under 37 CFR 1.99)</b>	Application Number		13675665
	Filing Date		2012-11-13
	First Named Inventor	David PANIAGUA	
	Art Unit		3738
	Examiner Name	not assigned	
	Attorney Docket Number		109978.10101

34	IOPATCH(R) Tutoplast(R) Processed Pericardium Directions for Use; <a href="http://www.iopinc.com/surgeons_and_medical_professionals/iopatch/directions.asp">http://www.iopinc.com/surgeons_and_medical_professionals/iopatch/directions.asp</a> , printed on June 2, 2009	<input type="checkbox"/>
35	KNUDSEN, LL et al., "Catheter-implanted prosthetic heart valves. Transluminal catheter implantation of a new expandable artificial heart valve in the descending thoracic aorta in isolated vessels and closed chest pigs" Int J. Artif Organs, May 1993, 16(5); pp. 253-62	<input type="checkbox"/>
36	LAX, Jorge A., M.D., et al. "Estimation of the Ejection Fraction in Patients with Myocardial Infarction Obtained from the Combined Index of Systolic and Diastolic Left Ventricular Function: A New Method" J of the American Soc of Echocardiography, Vol 13, No. 2	<input type="checkbox"/>
37	LIAO, Jun et al., "Molecular orientation of collagen in intact planar connective tissues under biaxial stretch" Acta Biomaterialia, Vol. 1, Iss. 1, January 2005, pp 45-54	<input type="checkbox"/>
38	LIAO, K X et al., "Two-dimensional mechanical and ultrastructural correlates of bovine pericardium for prosthetic valves" ASAIO Trans, June 1, 1991, 37(3); M341-51	<input type="checkbox"/>
39	LS, Yu et al., "New Polyurethane valves in new soft artificial heart" ASAIO Trans 1989 Jul-Sep; 35(3), pp. 301-304	<input type="checkbox"/>
40	MIRNAJAFI, A. et al. "The effects of collagen fiber orientation of the flexural properties of pericardial heterograft biomaterials" Biomaterials, 2005 Mar; 26(7): 795-804	<input type="checkbox"/>
41	MIRZAIE, M. et al., "A new storage solution for porcine aortic valves" Ann Thorac Cardiovasc Surg. 2007 Apr;13 (2):102-9	<input type="checkbox"/>
42	MOAZAMI, N. et al., "Transluminal aortic valve placement. A feasibility study with a newly designed collapsible aortic valve" ASAIO J, Sept-Oct 1996, 42(5):M 381-5	<input type="checkbox"/>
43	NIENABER C., M.D. et al., "Nonsurgical Reconstruction of Thoracic Aortic Dissection By Stent-Graft Placement" N. Eng. J. Med, May 20, 1999, Col. 340, No. 20	<input type="checkbox"/>
44	NOORLANDER, Maril L. et al., "A Quantitative Method to Determine the Orientation of Collagen Fibers in the Dermis" The J. of Histochemistry & Cytochemistry, Vol 50(11): 2002, pp. 1469-1474	<input type="checkbox"/>

<b>INFORMATION DISCLOSURE STATEMENT BY APPLICANT ( Not for submission under 37 CFR 1.99)</b>	Application Number	13675665
	Filing Date	2012-11-13
	First Named Inventor	David PANIAGUA
	Art Unit	3738
	Examiner Name	not assigned
	Attorney Docket Number	109978.10101

45	NUNN, D.B., "Structural Failure of Dacron Arterial Grafts" Seminars in Vascular Surgery, Col 12, No. 1 (March), 1999, pp. 88-91	<input type="checkbox"/>
46	Optical Microscope, Wikipedia, <a href="http://en.wikipedia.org/wiki/Stereomicroscope">http://en.wikipedia.org/wiki/Stereomicroscope</a> , May 13, 2009	<input type="checkbox"/>
47	Orthogonality, <a href="http://en.wikipedia.org/wiki/Orthogonal">http://en.wikipedia.org/wiki/Orthogonal</a> , May 13, 2009	<input type="checkbox"/>
48	PANIAGUA, DAVID, ET AL., Percutaneous Heart Valve In the Chronic In Vitro Testing Model, Circulation, 2002, pp. 51-52, Vol. 106, American Heart Association, US.	<input type="checkbox"/>
49	PANIAGUA, DAVID ET AL., First Human Case of Retrograde Transcatheter Implantation of an Aortic Valve Prosthesis, Texas Heart Institute Journal, 2005, pp. 91-96, Vol. 32, US.	<input type="checkbox"/>
50	PANIAGUA, DAVID et al., Abstract 4622: "Percutaneous Implantation of a Low Profile, Dry Membrane, Heart Valve in an Integrated Delivery System in the Aortic and Pulmonary Positions: One-month Animal Results," Circulation, American Heart Association, Inc., 2009; 120: S982	<input type="checkbox"/>

If you wish to add additional non-patent literature document citation information please click the Add button **Add**

**EXAMINER SIGNATURE**

Examiner Signature		Date Considered	
--------------------	--	-----------------	--

\*EXAMINER: Initial if reference considered, whether or not citation is in conformance with MPEP 609. Draw line through a citation if not in conformance and not considered. Include copy of this form with next communication to applicant.

<sup>1</sup> See Kind Codes of USPTO Patent Documents at [www.USPTO.GOV](http://www.USPTO.GOV) or MPEP 901.04. <sup>2</sup> Enter office that issued the document, by the two-letter code (WIPO Standard ST.3). <sup>3</sup> For Japanese patent documents, the indication of the year of the reign of the Emperor must precede the serial number of the patent document. <sup>4</sup> Kind of document by the appropriate symbols as indicated on the document under WIPO Standard ST.16 if possible. <sup>5</sup> Applicant is to place a check mark here if English language translation is attached.

<b>INFORMATION DISCLOSURE STATEMENT BY APPLICANT</b> ( Not for submission under 37 CFR 1.99)	Application Number	13675665
	Filing Date	2012-11-13
	First Named Inventor	David PANIAGUA
	Art Unit	3738
	Examiner Name	not assigned
	Attorney Docket Number	109978.10101

**CERTIFICATION STATEMENT**

Please see 37 CFR 1.97 and 1.98 to make the appropriate selection(s):

That each item of information contained in the information disclosure statement was first cited in any communication from a foreign patent office in a counterpart foreign application not more than three months prior to the filing of the information disclosure statement. See 37 CFR 1.97(e)(1).

**OR**

That no item of information contained in the information disclosure statement was cited in a communication from a foreign patent office in a counterpart foreign application, and, to the knowledge of the person signing the certification after making reasonable inquiry, no item of information contained in the information disclosure statement was known to any individual designated in 37 CFR 1.56(c) more than three months prior to the filing of the information disclosure statement. See 37 CFR 1.97(e)(2).

See attached certification statement.

The fee set forth in 37 CFR 1.17 (p) has been submitted herewith.

A certification statement is not submitted herewith.

**SIGNATURE**

A signature of the applicant or representative is required in accordance with CFR 1.33, 10.18. Please see CFR 1.4(d) for the form of the signature.

Signature	/ Mark L. Yaskanin /	Date (YYYY-MM-DD)	2013-09-23
Name/Print	Mark L. Yaskanin	Registration Number	45246

This collection of information is required by 37 CFR 1.97 and 1.98. The information is required to obtain or retain a benefit by the public which is to file (and by the USPTO to process) an application. Confidentiality is governed by 35 U.S.C. 122 and 37 CFR 1.14. This collection is estimated to take 1 hour to complete, including gathering, preparing and submitting the completed application form to the USPTO. Time will vary depending upon the individual case. Any comments on the amount of time you require to complete this form and/or suggestions for reducing this burden, should be sent to the Chief Information Officer, U.S. Patent and Trademark Office, U.S. Department of Commerce, P.O. Box 1450, Alexandria, VA 22313-1450. **DO NOT SEND FEES OR COMPLETED FORMS TO THIS ADDRESS. SEND TO: Commissioner for Patents, P.O. Box 1450, Alexandria, VA 22313-1450.**



## Privacy Act Statement

The Privacy Act of 1974 (P.L. 93-579) requires that you be given certain information in connection with your submission of the attached form related to a patent application or patent. Accordingly, pursuant to the requirements of the Act, please be advised that: (1) the general authority for the collection of this information is 35 U.S.C. 2(b)(2); (2) furnishing of the information solicited is voluntary; and (3) the principal purpose for which the information is used by the U.S. Patent and Trademark Office is to process and/or examine your submission related to a patent application or patent. If you do not furnish the requested information, the U.S. Patent and Trademark Office may not be able to process and/or examine your submission, which may result in termination of proceedings or abandonment of the application or expiration of the patent.

The information provided by you in this form will be subject to the following routine uses:

1. The information on this form will be treated confidentially to the extent allowed under the Freedom of Information Act (5 U.S.C. 552) and the Privacy Act (5 U.S.C. 552a). Records from this system of records may be disclosed to the Department of Justice to determine whether the Freedom of Information Act requires disclosure of these records.
2. A record from this system of records may be disclosed, as a routine use, in the course of presenting evidence to a court, magistrate, or administrative tribunal, including disclosures to opposing counsel in the course of settlement negotiations.
3. A record in this system of records may be disclosed, as a routine use, to a Member of Congress submitting a request involving an individual, to whom the record pertains, when the individual has requested assistance from the Member with respect to the subject matter of the record.
4. A record in this system of records may be disclosed, as a routine use, to a contractor of the Agency having need for the information in order to perform a contract. Recipients of information shall be required to comply with the requirements of the Privacy Act of 1974, as amended, pursuant to 5 U.S.C. 552a(m).
5. A record related to an International Application filed under the Patent Cooperation Treaty in this system of records may be disclosed, as a routine use, to the International Bureau of the World Intellectual Property Organization, pursuant to the Patent Cooperation Treaty.
6. A record in this system of records may be disclosed, as a routine use, to another federal agency for purposes of National Security review (35 U.S.C. 181) and for review pursuant to the Atomic Energy Act (42 U.S.C. 218(c)).
7. A record from this system of records may be disclosed, as a routine use, to the Administrator, General Services, or his/her designee, during an inspection of records conducted by GSA as part of that agency's responsibility to recommend improvements in records management practices and programs, under authority of 44 U.S.C. 2904 and 2906. Such disclosure shall be made in accordance with the GSA regulations governing inspection of records for this purpose, and any other relevant (i.e., GSA or Commerce) directive. Such disclosure shall not be used to make determinations about individuals.
8. A record from this system of records may be disclosed, as a routine use, to the public after either publication of the application pursuant to 35 U.S.C. 122(b) or issuance of a patent pursuant to 35 U.S.C. 151. Further, a record may be disclosed, subject to the limitations of 37 CFR 1.14, as a routine use, to the public if the record was filed in an application which became abandoned or in which the proceedings were terminated and which application is referenced by either a published application, an application open to public inspections or an issued patent.
9. A record from this system of records may be disclosed, as a routine use, to a Federal, State, or local law enforcement agency, if the USPTO becomes aware of a violation or potential violation of law or regulation.



(11) **EP 1 441 672 B1**

(12) **EUROPEAN PATENT SPECIFICATION**

(45) Date of publication and mention of the grant of the patent:  
**14.09.2011 Bulletin 2011/37**

(21) Application number: **02804403.0**

(22) Date of filing: **11.10.2002**

(51) Int Cl.:  
**A61F 2/24 (2006.01)**

(86) International application number:  
**PCT/US2002/032588**

(87) International publication number:  
**WO 2003/047468 (12.06.2003 Gazette 2003/24)**

(54) **IMPLANTABLE PROSTHETIC VALVE**  
IMPLANTIERBARE KLAPPENPROTHESE  
VALVE PROTHETIQUE IMPLANTABLE

(84) Designated Contracting States:  
**AT BE BG CH CY CZ DE DK EE ES FI FR GB GR  
IE IT LI LU MC NL PT SE SK TR**

(30) Priority: **11.10.2001 US 975750**

(43) Date of publication of application:  
**04.08.2004 Bulletin 2004/32**

(60) Divisional application:  
**08021823.3 / 2 055 266  
11005557.1  
11005559.7**

(73) Proprietor: **Edwards Lifesciences PVT, Inc.**  
Irvine, CA 92614 (US)

(72) Inventors:  
• **SPENSER, Benjamin**  
Caeserea (IL)

- **BENICHU, Netanel**  
Hof-Carmel (IL)
- **BASH, Assaf**  
37808 Givat Ada (IL)
- **ZAKAI, Avraham**  
Zichon Yaacov (IL)

(74) Representative: **Müller-Boré & Partner**  
Patentanwälte  
Grafinger Straße 2  
81671 München (DE)

(56) References cited:  
**EP-A- 0 850 607 WO-A-01/76510  
FR-A- 2 788 217 US-A- 5 840 081  
US-B1- 6 454 799 US-B1- 6 458 153**

**EP 1 441 672 B1**

Note: Within nine months of the publication of the mention of the grant of the European patent in the European Patent Bulletin, any person may give notice to the European Patent Office of opposition to that patent, in accordance with the Implementing Regulations. Notice of opposition shall not be deemed to have been filed until the opposition fee has been paid. (Art. 99(1) European Patent Convention).

**Description**

## FIELD OF THE INVENTION

**[0001]** The present invention relates to implantable devices. More particularly, it relates to a valve prosthesis for cardiac implantation or for implantation in other body ducts.

## BACKGROUND OF THE INVENTION

**[0002]** There are several known prosthetic valves that have been previously described. U.S. Patent No. 5,411,552 (Andersen et al.), entitled VALVE PROSTHESIS FOR IMPLANTATION IN THE BODY AND CATHETER FOR IMPLANTING SUCH VALVE PROSTHESIS, discloses a valve prosthesis comprising a stent made from an expandable cylinder-shaped thread structure comprising several spaced apices. The elastically collapsible valve is mounted on the stent with the commissural points of the valve secured to the projecting apices, which prevents the valve from turning inside out. Deployment of the valve can be achieved by using an inflatable balloon which in its deflated state is used to carry about it the valve structure to its position and, when inflated, deploys the stent in position to its final size. See, also, U.S. Patent No. 6,168,614 (Andersen et al.) entitled VALVE PROSTHESIS FOR IMPLANTATION IN THE BODY and U.S. Patent No. 5,840,081 (Andersen et al.), entitled SYSTEM AND METHOD FOR IMPLANTING CARDIAC VALVES.

**[0003]** In PCT/EP97/07337 (Letac, Cribier et al.), published as WO 98/29057, entitled VALVE PROSTHESIS FOR IMPLANTATION IN BODY CHANNELS, there is disclosed a valve prosthesis comprising a collapsible valve structure and an expandable frame on which the valve structure is mounted. The valve structure is composed of a valvular tissue compatible with the human body and blood, the valvular tissue being sufficiently supple and resistant to allow the valve structure to be deformed from a closed state to an opened state. The valvular tissue forms a continuous surface and is provided with guiding means formed or incorporated within, the guiding means creating stiffened zones which induce the valve structure to follow a patterned movement in its expansion to its opened state and in its turning back to its closed state. The valve structure can be extended to an internal cover which is fastened to the lower part of the valve structure to prevent regurgitation.

**[0004]** Further, the French patent application FR 2 788 217 A discloses a prosthetic valve implantable by catheter insertion or surgically. The prosthetic valve comprises the features of the preamble of claim 1. It comprises, in particular, a rigid expansible structure and a valvular structure integral with the expansible structure and capable of being deformed to pass alternately from an open state to a closed state. The valvular structure is integrated at one end of the expansible structure, and extends ex-

ternally thereto.

**[0005]** There are several known methods currently used for replacing aortic valves and several types of artificial prosthetic devices. Mechanical valves are commonly used in several different designs (single and double flap) manufactured by well-known companies such as St. Jude, Medtronic, Sulzer, and others. Some of the main disadvantages of these devices are: a need for permanent treatment of anticoagulants, noisy operation, and a need for a large-scale operation to implant.

**[0006]** There is a wide range of biologically based valves made of natural valves or composed of biological materials such as pericardial tissue. These too are made and marketed by well-known companies such as Edwards Lifesciences, Medtronic, Sulzer, Sorin, and others.

**[0007]** Polymer valves are new and are not yet in use, but several companies are in the process of developing such products. A new type of prosthesis is being considered, based on artificial polymer materials such as polyurethane..

**[0008]** The present invention introduces several novel structural designs for implantable valves. An aspect of the present invention deals with the possibility of implanting the valve percutaneously, i.e., inserting the valve assembly on a delivery device similar to a catheter, then implanting the valve at the desired location via a large blood vessel such as the femoral artery, in a procedure similar to other known interventional cardiovascular procedures. The percutaneous deployment procedure and device has an impact on the product design in several parameters, some of which are explained hereinafter.

**[0009]** The percutaneous implantation of medical devices and particularly prosthetic valves is a preferred surgical procedure for it involves making a very small perforation in the patient's skin (usually in the groin or armpit area) under local anesthetic and sedation, as opposed to a large chest surgery incision, which requires general anesthesia, opening a large portion of the chest, and cardiopulmonary bypass. This percutaneous procedure is therefore considered safer.

**[0010]** The present invention provides a series of new concepts in the field of aortic valves and other human valves.

## SUMMARY OF THE INVENTION

**[0011]** A valve prosthesis device which is not part of the present invention suitable for implantation in body ducts comprises:

a support stent, comprised of a deployable construction adapted to be initially crimped in a narrow configuration suitable for catheterization through the body duct to a target location and adapted to be deployed by exerting substantially radial forces from within by means of a deployment device to a deployed state in the target location, the support stent provided with a plurality of longitudinally rigid support

beams of fixed length; and

a valve assembly comprising a flexible conduit having an inlet end and an outlet, made of pliant material attached to the support beams providing collapsible slack portions of the conduit at the outlet,

whereby when flow is allowed to pass through the valve prosthesis device from the inlet to the outlet the valve assembly is kept in an open position, whereas a reverse flow is prevented as the collapsible slack portions of the valve assembly collapse inwardly providing blockage to the reverse flow.

[0012] Furthermore, the support stent may comprise an annular frame.

[0013] Furthermore, said valve assembly may have a tricuspid configuration.

[0014] Furthermore, said valve assembly may be made from biocompatible material.

[0015] Furthermore, the valve assembly may be made from pericardial tissue, or other biological tissue.

[0016] Furthermore, said valve assembly may be made from biocompatible polymers.

[0017] Furthermore, the valve assembly may be made from materials selected from the group consisting of polyurethane and polyethylene terephthalate (PET).

[0018] Furthermore, said valve assembly may comprise a main body made from PET (polyethylene terephthalate) and leaflets made from polyurethane.

[0019] Furthermore, said support stent may be made from nickel titanium.

[0020] Furthermore, the support beams may be substantially equidistant and substantially parallel so as to provide anchorage for the valve assembly.

[0021] Furthermore, the support beams may be provided with bores so as to allow stitching or tying of the valve assembly to the beams.

[0022] Furthermore, the support beams may be chemically adhered to the support stent.

[0023] Furthermore, said valve assembly may be riveted to the support beams.

[0024] Furthermore, said valve assembly may be stitched to the support beams.

[0025] Furthermore, said beams may be manufactured by injection using a mold, or by machining.

[0026] Furthermore, said valve assembly may be rolled over the support stent at the inlet.

[0027] Furthermore, said valve device may be manufactured using forging or dipping techniques.

[0028] Furthermore, said valve assembly leaflets may be longer than needed to exactly close the outlet, thus when they are in the collapsed state substantial portions of the leaflets fall on each other creating better sealing.

[0029] Furthermore, said valve assembly may be made from coils of a polymer, coated by a coating layer of same polymer.

[0030] Furthermore, said polymer may be poly-

urethane.

[0031] Furthermore, the support stent may be provided with heavy metal markers so as to enable tracking and determining the valve device position and orientation.

[0032] Furthermore, the heavy metal markers may be selected from gold, platinum, iridium, or tantalum.

[0033] Furthermore, the valve assembly leaflets may be provided with radio-opaque material at the the valve assembly leaflets may be provided with radio-opaque material at the outlet, so as to help tracking the valve device operation *in vivo*.

[0034] Furthermore, said radio-opaque material may comprise gold thread.

[0035] Furthermore, the diameter of said support stent, when fully deployed may be in the range of from about 19 to about 25 mm.

[0036] Furthermore, the diameter of said support stent may be expanded from about 4 to about 25 mm.

[0037] Furthermore, the support beams may be provided with bores and wherein the valve assembly may be attached to the support beams by means of U-shaped rigid members that are fastened to the valve assembly and that are provided with extruding portions that fit into matching bores on the support beams.

[0038] Furthermore, the support beams may comprise rigid support beams in the form of frame construction, and the valve assembly pliant material may be inserted through a gap in the frame and a fastening rod may be inserted through a pocket formed between the pliant material and the frame and holds the valve in position.

[0039] Furthermore, the main body of the valve assembly may be made from coiled wire coated with coating material.

[0040] Furthermore, the coiled wire and the coating material may be made from polyurethane.

[0041] Furthermore, a strengthening wire may be interlaced in the valve assembly at the outlet of the conduit so as to define a fault line about which the collapsible slack portion of the valve assembly may flap.

[0042] Furthermore, the strengthening wire may be made from nickel titanium alloy.

[0043] Furthermore, there is provided a valve prosthesis device which is not part of the present invention, suitable for implantation in body ducts, the device comprising a main conduit body having an inlet and an outlet and pliant leaflets attached at the outlet so that when a flow passes through the conduit from the inlet to the outlet the leaflets are in an open position allowing the flow to exit the outlet, and when the flow is reversed the leaflets collapse so as to block the outlet, wherein the main body is made from PET and collapsible leaflets are made from polyurethane.

[0044] Furthermore, support beams made from polyurethane may be provided on the main body and wherein the leaflets may be attached to the main body at the support beams.

[0045] Furthermore, said support beams may be chemically adhered to the main body.

**[0046]** Furthermore, there is provided a valve prosthesis device, which is not part of the present invention suitable for implantation in body ducts, the device comprising:

a support stent, comprised of a deployable construction adapted to be initially crimped in a narrow configuration suitable for catheterization through the body duct to a target location and adapted to be deployed by exerting substantially radial forces from within by means of a deployment device to a deployed state in the target location, the support stent provided with a plurality of longitudinally rigid support beams of fixed length;

a valve assembly comprising a flexible conduit having an inlet end and an outlet, made of pliant material attached to the support beams providing collapsible slack portions of the conduit at the outlet; and

substantially equidistant rigid support beams interlaced or attached to the slack portion of the valve assembly material, arranged longitudinally.

**[0047]** Furthermore, there may be provided a crimping device for crimping the valve device described above, the crimping device comprising a plurality of adjustable plates that resemble a typical SLR (Single Lens Reflex) camera variable restrictor, each provided with a blade, that are equally dispersed in a radial symmetry but each plate moves along a line passing off an opening in the center, all plates equidistant from that center opening.

**[0048]** Furthermore, the multiple plates may be adapted to move simultaneously by means of a lever and transmission.

**[0049]** Furthermore, there is provided a method for deploying an implantable prosthetic valve device from the retrograde approach (approaching the aortic valve from the descending aorta) or from the antegrade approach (approaching the aortic valve from the left ventricle after performing a trans-septal puncture) at the natural aortic valve position at the entrance to the left ventricle of a myocardium of a patient, which is not part of the present invention, the method comprising the steps of:

(a) providing a balloon catheter having a proximal end and a distal end, having a first and second independently inflatable portions, the first inflatable portion located at the distal end of the catheter and the second inflatable portion adjacently behind the first inflatable portion;

(b) providing a guiding tool for guiding the balloon catheter in the vasculature of the patient;

(c) providing a deployable implantable valve prosthesis device adapted to be mounted on the second inflatable portion of the balloon catheter;

(d) for the retrograde approach, guiding the balloon catheter through the patient's aorta using the guiding tool, the valve device mounted over the second inflatable portion of the balloon catheter until the first inflatable portion of the balloon catheter is inserted into the left ventricle, whereas the second inflatable portion of the balloon catheter is positioned at the natural aortic valve position;

(e) for the antegrade approach, guiding the balloon catheter through the patient's greater veins, right atrium, left atrium, and left ventricle using the guiding tool, the valve device mounted over the second inflatable portion of the balloon catheter until the first inflatable portion of the balloon catheter is inserted into the left ventricle, whereas the second inflatable portion of the balloon catheter is positioned at the natural aortic valve position;

(f) inflating the first inflatable portion of the balloon catheter so as to substantially block blood flow through the natural aortic valve and anchor the distal end of the balloon catheter in position;

(g) inflating the second inflatable portion of the balloon catheter so as to deploy the implantable prosthetic valve device in position at the natural aortic valve position;

(h) deflating the first and second inflatable portions of the balloon catheter; and

(i) retracting the balloon catheter and removing it from the patient's body.

**[0050]** Furthermore, the guiding tool may comprise a guide wire.

**[0051]** Furthermore, there is provided a method for deploying an implantable prosthetic valve device at the natural aortic valve position at the entrance to the left ventricle of a myocardium of a patient, which is not part of the present invention, the method comprising the steps of:

(a) providing a balloon catheter having a proximal end and a distal end, having a first and second independently inflatable portions, the first inflatable portion located at the distal end of the catheter and the second inflatable portion adjacently behind the first inflatable portion;

(b) providing a guiding tool for guiding the balloon catheter in the vasculature of the patient;

(c) providing a deployable implantable valve prosthesis device adapted to be mounted on the first inflatable portion of the balloon catheter, and a deployable annular stent device adapted to be mounted

over the second inflatable portion of the balloon catheter, the deployable implantable valve prosthesis device and the deployable annular stent kept at a predetermined distant apart;

(d) guiding the balloon catheter through the patient's aorta using the guiding tool, the valve device mounted over the first inflatable portion of the balloon catheter and the deployable annular stent mounted over the second inflatable portion of the balloon catheter, until the first inflatable portion of the balloon catheter is positioned at the natural aortic valve position;

(e) inflating the second inflatable portion of the balloon catheter so that the deployable stent device is deployed within the aorta thus anchoring the deployable annular stent and the coupled valve device in position;

(f) inflating the first inflatable portion of the balloon catheter so as to deploy the implantable prosthetic valve device in position at the natural aortic valve position;

(g) deflating the first and second inflatable portions of the balloon catheter; and

(h) retracting the balloon catheter and removing it from the patient's body.

**[0052]** The present invention is a valve prosthesis device as defined in claim 1.

**[0053]** Furthermore, the support beams may have a U-shaped cross section, which is not part of the present invention.

**[0054]** Furthermore, a holder may be used to secure the pliant material to the support beams, which is not part of the present invention.

**[0055]** Furthermore, the support frame may comprise three segments that form a circular assembly when assembled, which is not part of the present invention.

**[0056]** Furthermore, the support beams may point inwardly with respect to a central longitudinal axis of the device, which is not part of the present invention.

**[0057]** Furthermore, the device may be further provided with a restricting tapered housing, for housing it in a crimped state, which is not part of the present invention.

**[0058]** Furthermore, hooks may be provided to secure the device in position after it is deployed, which is not part of the present invention.

**[0059]** Furthermore, the support beams may comprise longitudinal bars having a narrow slit used as the commissural attachment so that extensions the pliant material are tightly inserted through it, which is not part of the present invention.

**[0060]** Furthermore, the extensions of the pliant material may be wrapped about rigid bars serving as anchorage means, which is not part of the present invention.

**[0061]** Furthermore, extensions of the pliant material may be sutured to each other at the rigid bars, which is not part of the present invention.

**[0062]** Furthermore, in accordance with another preferred embodiment of the present invention, a bottom portion of the pliant material is attached to the inlet

**[0063]** Furthermore, the support beams may be each provided with a rounded pole, forming a loop through which the pliant material is inserted, which is not part of the present invention.

**[0064]** Furthermore, the pliant material may be provided with longitudinal bars attached to the pliant material at positions assigned for attachment to the support frame, in order to prevent localized stress from forming, which is not part of the present invention.

**[0065]** Furthermore, the device may be further provided with longitudinal bars having protrusions that are inserted in bores in the pliant material, a sheet of PET and through bores provided on the support beams, which is not part of the present invention.

**[0066]** Furthermore, in accordance with another preferred embodiment of the present invention, pliant material is sutured leaving the slack portions free of sutures.

**[0067]** Furthermore, a connecting member with a split portion may be used to connect leaflets of the pliant material to the support beams, the split connecting member compressing the pliant material in position, which is not part of the present invention.

**[0068]** Furthermore, a portion of the connecting member could be perpendicular to the split portion, which is not part of the present invention.

**[0069]** Furthermore, the support frame may be provided with metallic members coupled to the stent and rigid members may be positioned on two opposite sides of the metallic member and held against each other holding portion of the pliant material between them, sutured, the metallic members wrapped with PET, which is not part of the present invention.

**[0070]** Furthermore, the device may be further provided with spring in order to reduce wear of the pliant material, which is not part of the present invention.

**[0071]** Furthermore, the spring may be provided with a spiral, which is not part of the present invention.

**[0072]** Furthermore, the spring may be made from stainless steel, which is not part of the present invention.

**[0073]** Furthermore, the spring may be attached to slots provided on the support frames, which is not part of the present invention.

**[0074]** Furthermore, the pliant material may be sutured to the support frame forming pockets, which is not part of the present invention.

**[0075]** Furthermore, attachment bars may be provided on the stent support at a portion of the stent close to the outlet, onto which the pliant material is coupled, and wherein the pliant material is attached circumferentially to the inlet, leaving slack pliant material, which is not part of the present invention.

**[0076]** Furthermore, in accordance with another pre-

ferred embodiment of the present invention, the outlet is tapered with respect to the inlet.

**[0077]** Furthermore, in accordance with another preferred embodiment of the present invention, the support frame at the outlet is wider in diameter than the pliant material forming the outlet.

**[0078]** Furthermore, in accordance with another preferred embodiment of the present invention, the pliant material is reinforced using PET.

**[0079]** Furthermore, the support frame may be a tube having an inner wall, having sinusoidal fold lines, wherein the pliant material is sutured to the inner wall of the tube along suture lines, which is not part of the present invention.

**[0080]** Furthermore, additional piece of PET may be added below the suture lines, which is not part of the present invention.

**[0081]** Furthermore, in accordance with another preferred embodiment of the present invention, the device is incorporated with an angioplasty balloon.

**[0082]** Finally, in accordance with another preferred embodiment of the present invention, balloon has a central longitudinal axis that runs along a flow path through the device, and a perimeter, the balloon comprising four inflatable portions, one portion located along a central axis and the other three located on the perimeter, the pliant material in the form of leaflets is distributed about the perimeter.

#### BRIEF DESCRIPTION OF THE FIGURES

**[0083]** To better understand the present invention and appreciate its practical applications, the following Figures are provided and referenced hereafter. It should be noted that the Figures are given as examples only and in no way limit the scope of the invention as defined in the appended claims.

Figure 1 illustrates an implantable prosthetic tricuspid valve suitable for percutaneous deployment using a stent or similar deploying means, in its deployed-inflated position;

Figure 2 depicts an implantable valve mounted over a deploying stent with an inflatable balloon;

Figure 3 illustrates an implantable valve mounted over a stent with an inflatable balloon, in a crimped position;

Figure 4 depicts implantable valve deployment in a natural aortic valve position;

Figure 5 demonstrates manufacturing a polyurethane implantable valve using a dipping technique;

Figures 6a to 6e illustrate manufacturing of an im-

plantable valve by forging;

Figures 7a and 7b demonstrate composite valve, which has polyurethane (PU) leaflets and PET tubular-crown shaped construction;

Figures 8a and 8b depict a manufacture process of a composite valve made of flexible PU leaflets, rigid PU construction for mounting and a PET tubular end;

Figures 9 to 9i demonstrate different methods of attachment between the valve and stent;

Figure 10 illustrates a dipping mandrel with an extra portion, which improves the sealing ability of the valve;

Figures 11a to 11c illustrate a valve mounted on a stent with an extra support, which improves the force distribution on the valve material and facilitates prolonged durability of the valve;

Figures 12a to 12c depict a valve with rigid supports located substantially in the center of its leaflets. This design allows the valve leaflets to perform without outer support;

Figures 13a to 13c illustrate the manufacturing of a reinforced PU tube composed of strong fiber from PU, PET or other and a softer PU coating, for serving as the supporting structure;

Figures 14a to 14c demonstrate incorporation of heavy metal markers on the stent. These markers allow orientation control while positioning the device at the required location;

Figures 15a to 15c demonstrate a valve with radio-opaque coating which allows imaging of the valve motion under angiogram;

Figures 16a to 16c illustrate a procedure, which helps in accurate positioning the valve device with respect to the longitudinal orientation;

Figures 17a and 17b describe a valve device comprising one valve assembly mounted on a stent and an additional portion with a stent only. This allows placing the device in a way that coronaries are not blocked, longitudinal positioning thus becomes less sensitive and the extra stent decreases the risk of device migration within the vasculature;

Figures 18a and 18b demonstrate a crimping device which can crimp a valve device in the operating theater as part of the implantation procedure;

Figures 19a to 19c depict a crimping machine similar

to the one described in figure 18 with a different mechanical method;

Figures 20a and 20b demonstrate a valve made of a tube mounted on a stent. During systole the tube is fully open and during diastole the tube collapses according to the mounting geometry providing tight sealing;

Figure 21 depicts a stent structure with built-in mounting portions of constant length, which allow valve mounting;

Figure 22 depicts a valve assembly having dilated supports;

Figures 23a to 23e depict stages in a method of manufacturing an implantable prosthetic valve.

Figures 24a to 24c illustrate a support frame of an implantable prosthetic valve having means for mounting valve leaflets that can form a tricuspid valve. Figure 24a depicts an isometric view of the frame, and Figure 24b depicts a cross-sectional view of the means for mounting a valve leaflet in details, provided with a valve leaflet Figure 24c depicts further details of attachment means for the attachment method;

Figures 25a to 25d illustrate an implantable prosthetic valve Figures 25a and 25b depict an isometric view and an upper view of the valve assembly, respectively, and Figures 25c and 25d illustrate upper views of two optional constructions for the means for mounting leaflets;

Figures 26a to 26c illustrate a tricuspid valve provided with a self-expandable frame. Figure 26a is the valve in its fully expanded diameter, Figure 26b is a tapered tool which assists in inserting the valve into an introducing tube, and Figure 26c shows the valve assembly inside a restriction tube, ready to be inserted into a introducing sheath;

Figure 27 illustrates an isometric view of an implantable prosthetic valve having hooks designated to anchor the valve assembly to body ducts;

Figure 28 illustrates a partial view of an implantable prosthetic valve. The commissural attachment is showed in details;

Figures 29a and 29b illustrate an isometric view and an upper cross-sectional view, respectively, of an attachment assembly of a valve's frame to leaflets.

Figures 30a to 30c illustrate an isometric view, a cross-sectional view and a flattened view, respec-

tively, of an attachment assembly of a valves frame to leaflets. Figure 30c is a side view showing two pieces of pericardium before the attachment to the frame;

Figures 31a and 31b illustrate an exploded view and an isometric view, respectively, of a commissural attachment depicting the attachment technique;

Figures 32a and 32b illustrate an isometric view of an attachment between leaflets and the frame.

Figures 33a to 33d illustrate different views and portions of an attachment between a pericardium and a frame demonstrating another method of attachment;

Figures 34a to 34c illustrate an isometric view of an attachment between a pericardium and a valve demonstrating another method of attachment In Figures 34b and 34c, a deployed portion and the folded portion, respectively, are shown;

Figures 35a to 35c illustrate isometric and cross-sectional upper views, respectively, of attachment techniques between a pericardium leaflet and a valve's frame;

Figures 36a and 36b illustrate an isometric view of a commissural assembly demonstrating a method of forming one;

Figures 37a to 37c illustrates a commissural assembly, where the connecting bar functions as a flexible support and has integral attachment means to the frame. Figure 37b is an isometric view of the connecting bar;

Figures 38a to 38g illustrate isometric views of flexible commissural supports and the method of attaching them to a pericardium and a frame and valve;

Figures 39a to 39b illustrate an isometric view of a commissural attachment demonstrating the attachment of the pericardium to the support by means of a shaped compressing member;

Figures 40a to 40c illustrate an isometric view of a bicuspid valve mounted on a frame. Figures 40b and 40c depicts a cross-sectional side view and an isometric view, respectively, of the pericardium that is sutured to a PET tube in the form of pockets;

Figures 41a to 41d illustrate isometric views of an implantable prosthesis tricuspid valve;

Figures 42a and 42b illustrate an isometric view of an implantable prosthetic valve having a different



commissural attachment. Figure 42b depicts the attachment in details;

Figures 43a and 43b illustrate an isometric view of an implantable prosthetic valve. Figure 43a depicts the commissure that are pre-sutured in a tapered shape;

Figures 44a to 44c illustrate an isometric view of an implantable prosthetic valve with additional pieces of PET used for sealing and protecting the pericardium;

Figures 45a to 45d illustrate an isometric view of an implantable prosthetic valve having leaflets sutured to a pre-shaped PET tube and optional leaflet-tube attachments in details;

Figures 46a and 46b illustrate an exploded view and an upper cross-sectional view of an implantable prosthetic valve assembly;

Figures 47a to 47c illustrate a partial cross-sectional side view of an inflating balloon. The balloon is a part of an implantable prosthetic valve delivery system. Figures 47b and 47c are cross sectional upper views in the inflated and deflated positions, respectively; and

Figures 48a and 48b illustrate a partial cross-sectional side view and an upper cross-sectional view of an inflating balloon.

#### DETAILED DESCRIPTION OF THE INVENTION

**[0084]** An aspect of the present invention is the introduction of several novel designs for an implantable prosthetic valve.

**[0085]** Basically the implantable prosthetic valve of the present invention comprises a leafed-valve assembly, preferably tricuspid but not limited to tricuspid valves only, consisting of a conduit having an inlet end and an outlet, made of pliant material arranged so as to present collapsible walls at the outlet. The valve assembly is mounted on a support structure such as a stent adapted to be positioned at a target location within the body duct and deploy the valve assembly by the use of deploying means, such as a balloon catheter or similar devices. In embodiments suitable for safe and convenient percutaneous positioning and deployment the annular frame is able to be posed in two positions, a crimped position where the conduit passage cross-section presented is small so as to permit advancing the device towards its target location, and a deployed position where the frame is radial extended by forces exerted from within (by deploying means) so as to provide support against the body duct wall, secure the valve in position and open itself so as to allow flow through the conduit.

**[0086]** The valve assembly can be made from biological matter, such as a natural tissue, pericardial tissue or other biological tissue. Alternatively, the valve assembly may be made from biocompatible polymers or similar materials. Homograph biological valves need occasional replacement (usually within 5 to 14 years), and this is a consideration the surgeon must take into account when selecting the proper valve implant according to the patient type. Mechanical valves, which have better durability qualities, carry the associated risk of long-term anticoagulation treatment.

**[0087]** The frame can be made from shape memory alloys such as nickel titanium (nickel titanium shape memory alloys, or NiTi, as marketed, for example, under the brand name Nitinol), or other biocompatible metals. The percutaneously implantable embodiment of the implantable valve of the present invention has to be suitable for crimping into a narrow configuration for positioning and expandable to a wider, deployed configuration so as to anchor in position in the desired target location.

**[0088]** The support stent is preferably annular, but may be provided in other shapes too, depending on the cross-section shape of the desired target location passage.

**[0089]** Manufacturing of the implantable prosthetic valve of the present invention can be done in various methods, by using pericardium or, for example, by using artificial materials made by dipping, injection, electrospinning, rotation, ironing, or pressing.

**[0090]** The attachment of the valve assembly to the support stent can be accomplished in several ways, such as by sewing it to several anchoring points on the support frame or stent, or riveting it, pinning it, adhering it, or welding it, to provide a valve assembly that is cast or molded over the support frame or stent, or use any other suitable way of attachment.

**[0091]** To prevent leakage from the inlet it is optionally possible to roll up some slack wall of the inlet over the edge of the frame so as to present rolled-up sleeve-like portion at the inlet.

**[0092]** Furthermore, floating supports may be added to enhance the stability of the device and prevent it from turning inside out

**[0093]** An important aspect of certain embodiments of the present invention is the provision of rigid support beams incorporated with the support stent that retains its longitudinal dimension while the entire support stent may be longitudinally or laterally extended.

**[0094]** The aforementioned embodiments as well as other embodiments, manufacturing methods, different designs and different types of devices are discussed and explained below with reference to the accompanying drawings. Note that the drawings are only given for the purpose of understanding the present invention and presenting some preferred embodiments of the present invention, but this does in no way limit the scope of the present invention as defined in the appended claims.

**[0095]** Reference is now made to Figure 1, which illustrates a general tricuspid implantable prosthetic valve 20

in accordance with a preferred embodiment of the present invention, suitable for percutaneous deployment using an expandable stent or similar deploying means, shown in its deployed position. A valve assembly 28 comprises a conduit having an inlet 24 and an outlet 26, the outlet walls consisting of collapsible pliant material 29 that is arranged to collapse in a tricuspid arrangement. The valve assembly 28 is attached to an annular support stent 22, the one in this figure being a net-like frame designed to be adapted to crimp evenly so as to present a narrow configuration and be radially deployable so as to extend to occupy the passage at the target location for implantation in a body duct. Support beams 23 are provided on annular support stent 22 to provide anchorage to valve assembly 28. Further support beams 23 are provided with bores 25 through which valve assembly 28 is stitched to support beams 23 by thread.

**[0096]** In the embodiment shown in Figure 1, a cuff portion 21 of the valve assembly 28 is wrapped around support stent 22 at inlet 24 to enhance the stability. Preferably cuff portion 21 of valve material 28 is attached to support beams 23.

**[0097]** Note that the entire valve structure is adapted to be radially crimped and radially expanded, and this lends to provide ease of navigation through narrow passages in the vasculature during positioning of the device and adequate deployment on the final location. This is made possible by the provision of a collapsible support stent structure. However, the support beams remain at all times constant at their length and thus are suitable for serving as the pliable valve assembly's anchorage. The valve assembly is attached to the support stent at the support beams, and due to their constant length there is no need for slack material as the attachment points (25) remain at constant distances regardless of the position of the valve device (crimped or deployed). This is an important feature for this means that the manufacturer of the valve device can make sure the valve assembly is secured and fastened to the support stent at all times. In prior art implantable valve devices the entire support structure changes its dimensions from its initial first crimped position and final deployed position, and this means that in the attachment of the valve assembly to the support structure one must take into consideration these dimension changes and leave slack material so that upon deployment of the device the valve assembly does not tear or deform. In the valve device of the present invention there is no relative movement between the valve assembly and the support beams (along the longitudinal central axis of the device). As a result, the valve device of the present invention acquires greater durability and is capable of withstanding the harsh conditions prevailing within the vasculature and especially the millions of cycles of stress applied by the blood pressure.

**[0098]** The fixed attachment of the valve assembly to the support stent in the valve device of the present invention results in greater stability, enhanced safety, better sealing and consequently longer lifespan. The novel

design of the valve device of the present invention leads to longitudinal strength and rigidity whereas its collapsible support structure results in radial flexibility.

**[0099]** Figure 2 depicts an implantable valve 30 mounted on a deployable stent 32. The valve assembly 34 is attached to the deployable support stent 32 (dotted lines) along three substantially equidistant and substantially parallel support beams 40 of constant length, which are part of stent 32. The attachment of valve assembly 34 to stent 32 is facilitated by the support beams 40 to which valve assembly 34 is stitched with thread or fiber 46 (through bores 42 of support beams 40). Outlet leaves 38, which are a slack portion of the valve assembly, dangle inwardly, and the whole device is carried by an inflatable balloon 48, which serves as the deploying device. A portion of the valve assembly 34 at an inlet zone 45 is optionally rolled over support stent 32 at the inlet, making up a rolled sleeve, which enhances the sealing of the device at the valve inlet.

**[0100]** Figure 3 demonstrates an implantable valve mounted to a stent 50 with an inflatable balloon 52, in a crimped position. The support stent 50 is initially crimped about the balloon 52 so that it presents a narrow cross-section and is thus suitable for percutaneous catheterization and deployment.

**[0101]** Figure 4 depicts an implantable valve deployment in a natural aortic valve position. The implantable valve is advanced while mounted over the balloon 52 until it reaches the desired target location 54 in a body duct, for example, aorta 56. The balloon is inflated and the support stent 50 expands radially to take up its position.

**[0102]** Figure 5 demonstrates the manufacture of a polyurethane valve in a dipping technique. A dipping mandrel 60 is provided with a tubular portion 62 with surfaces 64 that correspond to the collapsible valve leaflets to be manufactured. Mandrel 60 is dipped into a dissolved polyurethane bath 66 and is coated with a polyurethane coating in the desired form of the valve. Then, after the polyurethane coating has hardened sufficiently, the completed valve is removed from mandrel 60.

**[0103]** Figures 6a to 6e illustrate manufacturing an implantable valve by forging. A suitable tubularly shaped material 74 is placed tightly on a tubular portion 68 of mandrel 67, covering the cusp portion 69. Flexible inserts 76 are pressed to mandrel 67, forging the tubular material to mandrel shape 80. A tapered ring 70 holds the flexible inserts in place as the whole mold is placed in a hot oven regulated to a desired temperature, which is lower than the material's melting point. Figure 6e illustrates a sectional side view of the mandrel and a cross cut portion of the mold. The mold is made to press inwardly on the mandrel, which is covered with the valve material. As a result the material takes up the desired shape. The materials used can vary, for example, polyurethane (PU), polyethylene terephthalate (PET), or any other suitable material, which may be formed by heating.

**[0104]** Figures 7a and 7b demonstrate a method of

manufacturing a composite valve, which has PU leaflets and PET tubular construction with a crown shape. PU is an excellent fatigue resistant material but is sensitive to tear. The PU is reinforced by the PET crown to allow safe attachment to a stent by means of stitching, riveting, or any other suitable attachment method. A PET crown 86 is placed on a mandrel 87, which is then (turned and) dipped in a container of dissolved PU. The manufactured device is a valve assembly having leaflets 88 composed of pure PU, and thus fatigue resistant, and a main body made of PET with protruding attachment portions 90 suitable for attachment built in the PU.

**[0105]** Figures 8a and 8b demonstrate a method of manufacturing a composite valve, which is based on flexible PU 92 for as the main body of the valve, rigid PU support beams 94 serving for the attachment area, and PET sleeve 96 portions for the valve inlet. The need for a rigid portion for attachment (support beams 94) is explained by the tendency of the flexible, fatigue resistant material to tear as already explained. The advantage of the stiff PU support beams is that they are chemically adhered to the main body, and this improves the overall durability of the valve due to reduction of inner forces and friction in the attachment area specially attachment between two different materials. The valve is dipped in the method mentioned with reference to Figure 5, and the rigid PU support beam 94 is created by way of mold injection, machining or any other suitable way. The rigid PU support beam 94 is placed on the valve and then dipped into the container of dissolved PU. This is done while the valve is positioned on the mandrel (not shown). This method provides the ability to composite several materials into one body and, by that, gain the advantage of the various properties of the materials as they are needed in different areas of the prosthesis.

**[0106]** Figures 9 to 9i demonstrate different methods of attachment between a valve assembly and the support stents. A valve assembly 99 shown in Fig. 9 is incorporated into valve 100 shown in Fig. 9a, where a support stent 102 is attached to valve assembly 99 through support beam 106. A detail is shown in Fig. 9b, where, in cross-section, it can be seen that layer 108 is an optional inner support made of stainless steel or rigid polymeric material, valve assembly 99 comprises a PET layer 105 coated with a PU layer 104, with the outer support beam 106. Connector 107 is a connecting wire made of a strong material, such as stainless steel. Figure 9c illustrates an alternative arrangement for attachment by a rivet 109, and in Figure 9d the attachment is achieved by a suture 110.

**[0107]** Figures 9e to 9g show an attachment method comprising shaped rigid members 116, preferably made from metal, which tightly hold the PU valve material 118 by fitting in between a PU U-shaped nest 120 and are attached to a stent 122 by extruding portions 124 that are provided on U-shaped rigid member 116, which fit the bores 126 of the support beam 128 of the stent 122. Figures 9h and 9i show another attachment method,

where rigid support beams in the form of frame construction 132 are provided, and the valve assembly pliant material 135 made of a tubular material is inserted through a gap 137 in the frame. After insertion, a fastening rod 133 is inserted through the pocket formed between the pliant material and the frame and holds the valve in position.

**[0108]** Figure 10 illustrates a dipping mandrel 139 with an extending portion 141, which improves the sealing ability of the valve. Since the valve is attached to a collapsible stent and is itself collapsible, it is difficult to determine the exact shape of the valve after crimping and deploying. It is of major importance that sealing will be achieved. By adding the extension 141 the leaflets are made longer than needed to exactly close the outlet, and therefore when they are in the collapsed state, substantial portions of the leaflets fall on each other creating better sealing.

**[0109]** Figures 11a to 11c illustrate a valve assembly mounted on a support stent 144 with interlaced strengthening wire 146, which improves the force distribution on the valve material and facilitates prolonged durability of the valve. The support is in the form of a wire, which has a crown shape as the shape of the three cusp valve base 148, it also has the ability to be crimped 150 to a small diameter, together with the stent, valve and balloon, as shown in Fig. 11b. The forces applied to the valve edge 148 while working, are applied to the attachment points, by making the attachment line longer we reduce the force on each attachment point. In this support method the valve is attached by suturing 152 the entire line to the extra support wire 146. This wire can be made of stainless steel, nickel titanium alloy such as nitinol, or polymeric material. The support suture renders the valve assembly default fault lines where the valve material more readily flexes, thus ensuring proper operation of the valve flaps (leaflets). Optionally the valve assembly shown in Figures 11a to 11c can be mounted on a support stent such as the one described herein or similar supporting structures. The strengthening wire is interlaced in the valve assembly at the outlet of the conduit so as to define a fault line about which the collapsible slack portion 154 of the valve assembly may flap.

**[0110]** Figures 12a to 12c depict a valve device provided with a stent 159 and substantially equidistant rigid support beams 160, interlaced or attached to the slack portion of the valve assembly material 161, arranged longitudinally. This design allows the valve leaflets to perform without outer support. The support in standard valves is by tying the upper edge of the cusp to a rigid embodiment, so that it reacts to the load as a suspension bridge. In this new design the prevention of collapsing is achieved similar to an Indian tent, i.e., the rigid supports lean on each other 162 when the valve is closed but do not interfere in opening 164 when the valve is open.

**[0111]** Figures 13a to 13c illustrate the manufacturing of a valve assembly. At first a polyurethane thread line 170 is fed from a PU supply 172, and coiled around a

cylindrical drum 174 to form coil 176. Then, drum 174 with coil 176 is dipped in a PU bath 177, and a second layer 178 of the PU coats coil 176, making it a stronger construction capable of withstanding tearing forces both laterally and in other directions. Incorporating two different types of materials - such as PU and PET - may render greater durability and endurance to the valve assembly. This material is an alternative material to be used in the forging method shown in Figure 6.

**[0112]** Figures 14 to 14c demonstrate the incorporation of heavy metal markers on the stent, which markers allow observation and thereby adjustment of orientation while placing the device in the required location. Heavy metals are radiopaque, that is, they are conspicuous on an angioscopic image, which is a two-dimensional image. Since the coronary artery ostia 237 and 238 are located near the typical valve deployment location and must stay open, it is extremely important to make sure that the deployed valve assembly is not blocking a coronary ostium. In some cases the stent is lower than the ostium and in those cases it will stay open, but in some cases as shown in these figures it is necessary to make sure that the stent portion 239 that is connecting the valve supports 235 is opposite the coronary ostia, and in that way the blood supply is preserved through the stent struts. Two heavy metal markers 232 are attached at the outlet side, one marker 230 at the inlet side. It is possible to adjust the angioscopic view to the plane of the left coronary as shown in Figure 14b and anatomically locate the other accordingly. If the two upper markers 232 are placed in the radiographic two dimensional image, one on top of the other, and the low marker 230 on the opposite side, we make sure that the coronaries are open to blood flow as seen in Figure 14c. Gold, platinum, iridium or tantalum are all biocompatible materials suitable for the markers described above.

**[0113]** Figures 15a to 15c illustrate a valve with a portion of radio-opaque material 267 such as a thread of gold at the sealing edge. When a valve is implanted, it is very important to have clear indications of how the valve is functioning *in vivo*; pressure measurements, flow visualization, and doppler measurements are utilized. It is also possible to examine the valve by ultrasound methods, however, observing the opening and closing of the valve cusps on a monitor. Fig. 15b is an angiographic image 268 of the open valve, while image 169 in Figure 15c is the closed position as seen on the angiogram.

**[0114]** Figures 16a to 16c illustrate a procedure, which helps in placing the device in the longitudinal position. It is very important to place the device in the correct longitudinal position, for if it is too deep in the left ventricle it may interfere with the mitral valve function by improper closing or function of the valve. If it is positioned too high it may migrate, it may leak via the sinus cavities, which are located around it, and/or it may block the coronaries. It is a necessary task to position the valve prosthesis in a narrow target location. In Figure 14 a method of lateral orientation placement is shown, and Figures 16a to 16c

illustrate a longitudinal positioning. The valve device (the valve assembly and the support stent) is placed on an inflatable balloon catheter, comprising double independently inflatable chambers 303, 305, and is inserted into the left ventricle 302 in the crimped position and guided over a guiding stylet or guide wire 300. The balloon, which is larger than the annulus diameter when inflated, is inflated in the left ventricle 302, and then the whole device is pulled slightly backwards. The balloon is supported on the inner part of the annulus 303, allowing positioning of the device in the exact desired position. In addition, it temporarily blocks the blood flow, and that improves the ability to hold the device in place while inflating it. The next step is inflating the second balloon 305, which deploys the valve device in the desired location.

**[0115]** The method for deploying an implantable prosthetic valve device at the natural aortic valve position at the entrance to the left ventricle of a myocardium of a patient, as depicted in Figures 16a, 16b and 16c, comprises the steps of:

(a) providing a balloon catheter having a proximal end and a distal end, having a first and second independently inflatable portions, the first inflatable portion located at the distal end of the catheter and the second inflatable portion adjacently behind the first inflatable portion;

(b) providing a guiding tool for guiding the balloon catheter in the vasculature of the patient;

(c) providing a deployable implantable valve prosthesis device adapted to be mounted on the second inflatable portion of the balloon catheter

(d) guiding the balloon catheter through the patient's aorta using the guiding tool, the valve device mounted over the second inflatable portion of the balloon catheter until the first inflatable portion of the balloon catheter is inserted into the left ventricle, whereas the second inflatable portion of the balloon catheter is positioned at the natural aortic valve position;

(e) inflating the first inflatable portion of the balloon catheter so as to substantially block blood flow through the natural aortic valve and anchor the distal end of the balloon catheter in position;

(f) inflating the second inflatable portion of the balloon catheter so as to deploy the implantable prosthetic valve device in position at the natural aortic valve position;

(g) deflating the first and second inflatable portions of the balloon catheter; and

(h) retracting the balloon catheter and removing it from the patient's body.

**[0116]** Figure 17 describes a positioning of a valve device 310 using an additional deployable stent 320. There are several problems that may be encountered while deploying the stent and valve in the aortic valve location: blockage of coronaries may occur that is dangerous if the diameter of the stent is similar to that of the coronaries aortic root 309. Secondly, migration of the whole device may also occur, which is a dangerous possibility, and there is the problematic challenge of exact positioning of the valve device that is very difficult to accomplish, as already explained. The newly special designed device with a double diameter inflatable balloon and double stent design allows placement of the device in a way that coronaries will not be blocked because of a safe difference that is kept between the diameters, longitudinal placing is less sensitive because of the small diameter which ensures prevents over expansion of the valved prosthesis. The distal stent 320, which contains no valve, is expanded into the ascending aorta, while the proximal stent 310 is placed simultaneously in the annular position. This placement method is less challenging due to the smaller diameter of the proximal stent 310 which ensures that the mitral valve is not deformed by over-expansion as the dimensions are preserved, and the additional stent decreases the risk of device migration. It is safer to over dilate in the aorta, which is not true for the annulus.

**[0117]** The method for deploying an implantable prosthetic valve device at the natural aortic valve position at the entrance to the left ventricle of a myocardium of a patient, as depicted in Figures 17a and 17b, comprises the steps of:

(a) providing a balloon catheter having a proximal end and a distal end, having a first and second independently inflatable portions, the first inflatable portion located at the distal end of the catheter and the second inflatable portion adjacently behind the first inflatable portion;

(b) providing a guiding tool for guiding the balloon catheter in the vasculature of the patient;

(c) providing a deployable implantable valve prosthesis device adapted to be mounted on the first inflatable portion of the balloon catheter, and a deployable annular stent device adapted to be mounted over the second inflatable portion of the balloon catheter, the deployable implantable valve prosthesis device and the deployable annular stent kept at a predetermined distant apart;

(d) guiding the balloon catheter through the patient's aorta using the guiding tool, the valve device mounted over the first inflatable portion of the balloon catheter and the deployable annular stent mounted over the second inflatable portion of the balloon catheter, until the first inflatable portion of the balloon catheter is positioned at the natural aortic valve position;

(e) inflating the second inflatable portion of the balloon catheter so that the deployable stent device is deployed within the aorta thus anchoring the deployable annular stent and the coupled valve device in position;

(f) inflating the first inflatable portion of the balloon catheter so as to deploy the implantable prosthetic valve device in position at the natural aortic valve position;

(g) deflating the first and second inflatable portions of the balloon catheter; and

(h) retracting the balloon catheter and removing it from the patient's body. Figures 18a and 18b illustrate an accessory crimping device that is adapted to crimp a valve device in the operating theater as part of the implantation procedure. The crimping device 330 comprises several adjustable plates that resemble a typical SLR camera variable restrictor. It is comprised of simultaneously movable plates 332 each provided with a blade 334, that are equally dispersed in a radial symmetry but each plate moves along a line passing off an opening in the center, all plates equidistant from that center opening 336. Initially (see Figure 18a) the plates are drawn apart providing a large enough opening for the implantable valve to be positioned within that opening. When the plates are drawn towards the center (see Figure 18b), the opening 336 reduces in size but still retains the annular shape, and this facilitates the crimping of the valve frame to a small dimension suitable for percutaneous positioning.

**[0118]** Figures 19a depicts a crimping method for the support stent of the valve prosthesis device, whereby stent 340 is crimped, that is, compressed or curled. In Figure 19b a crimping device 343 is shown, comprising a body having an annular void in which an expanded stent is positioned. Lever 346 is connected to the end 347 of the stent and as the lever is pulled the stent is curled or compressed about axle 345 into a compressed position 349 (Figure 19c).

**[0119]** Figures 20a and 20b depict a valve made of a simple tube mounted to a stent 352. During systole period the tube is fully open and during diastole period the tube collapses according to the mounting geometry 357 and achieves sealing.

**[0120]** Figure 21 describes a newly designed support stent 360 in its open position. Three of the longitudinal struts 362 are full and thick and always stay with their original constant size, serving as anchoring support. Each of these struts 362 is provided with a plurality of bores 364, which are later used for mounting the valve assembly (not shown) and tying it to stent 360. Between struts 362 a web-like construction is provided, which is capable of being crimped to a narrow state and capable

of being deployed again to a wider state.

**[0121]** Figure 22 illustrates another implantable prosthetic valve. It comprises a metal tube 370, having three portions with a thicker wall 371 than in the rest of the tube 370, these areas form the longitudinal columns 372 in the construction, after the tube is cut to its final form. The advantage of such a construction is in its superior bending strength, in specific required portions of the construction, with minimal interference to the crimped volume of the whole construction.

**[0122]** Figure 23a to 23c depict a method of manufacturing an artificial or biological crimpable valve device. A piece of fabric material 370 (Fig. 23a), is dipped in PU to create a portion which is later formed into valve leaflets 371 (Fig. 23b). This composite material 371 is then attached to an additional piece of fabric such as PET 372 by means of stitching, suturing or other attaching technique 373 (Fig. 23c). The resulting fabric 375 is cut along stitching line 373 leaving enough material to later suture the valve assembly to the support construction. It is then formed to a tubular shape and stitched 374 (Fig. 23d). The tubular valve is then attached to a support construction 380 by suturing the bottom part around the valve 379 tightly to prevent leakage, and around the cut fabric line 376 (Fig. 23e). This open wall structure 378 allows blood flow to the coronary arteries. The valve is later placed with the coronary artery between the support columns 385. Additional variations of this can be made by replacing the composite material 371/370 with a biological patch such as a suitable pericardium patch. In some cases it is possible to make the same valve without cutting the fabric 372 with the shaped cut 376, and by that create a valve with an outer tubular shape. The embodiment of Figs. 23a to 23c is easy to manufacture as it is generally flat throughout most of the production process and only at the final stage of mounting on the support stent is it given a three-dimensional form.

**[0123]** Reference is now made to Figure 24a illustrating a frame of an implantable prosthetic valve having means for mounting valve leaflets that can form a tricuspid valve. Figure 24a depicts an isometric view of the frame and Figure 24b depicts a cross sectional view of the means for mounting valve leaflets 430 in detail. A frame 420, which is suitable for crimping and expanding, has three support beams 422 for mounting leaflets positioned substantially symmetrically about the circumference of the frame. Frame 420 is shown in Figure 24a in its deployed state. Support beam 422 has a "U" shaped lateral cross section, or profile (shown clearly in Figure 24b) that is designed to attach to a commissure of the valve structure. The "U" shape can be produced by extrusion, wire cutting or by welding the "U" profile to the frame's struts 421 at junction points 424. Support beam 422 is provided with a series of bores 425 positioned along its back wall. Bores 425 are designated for stitching the valve assembly by threads, wires, or other attaching means.

**[0124]** Figure 24b is a detailed cross-sectional view of

one of the support beam 422. Two pericardial leaflets 430 are inserted through a U-shaped, or forked holder 428 that compresses and restricts the leaflets in the U-shaped profile. Leaflets 430 are folded to both sides of the support beam 422. When holder 428 is compressed toward the support beam 422, leaflets 430 are caught in-between holder 428 and support beam 422 so that the leaflets are kept in place. Figure 24c is an exploded view of the holder, bar 426 has a series of bores compatible for attachment to the frames support beam 422, attachment being achieved by suture 423 or any other attachment means. This attachment method allows attaching the leaflets to the frame without puncturing it with sutures and needles. It is also important that the leaflets are firmly held in place by the holder 428 so that it has no relative movement in respect to the rigid frame; hence avoiding wear due to movements. Leaflets that are made from pericardium are known to better withstand inner movements and stresses and less to wear by movement against rigid, hard or sharp bodies.

**[0125]** It is noted again that the entire valve structure is adapted to be radially crimped and radially expanded. This feature imparts the valve with the ability and ease to navigate through narrow passages in the vasculature during positioning of the device. After final positioning of the valve, the valve is deployed. This is made possible by the provision of a collapsible support frame structure. However, the length of the attaching means (the height of the valve) remains at all times constant; thus suitable for serving as the pliable valve assembly's anchorage. The leaflets are attached to the support frame at the attaching means, and due to their constant length there is no need for slack material as these attachment points that remain at constant distances regardless of the position of the valve assembly (crimped or deployed). This is an important feature for this means that the manufacturer of the valve device can make sure the valve assembly is secured and fastened to the support frame at all times. In prior art implantable valve devices, the entire support structure changes its dimensions from its initial first crimped position to final deployed position and this means that in the attachment of the valve leaflets to the support structure one must take into consideration these dimension changes and leave slack material so that upon deployment of the device, the valve assembly does not tear or deform. In the valve device of the present invention there is no relative movement between the valve leaflets and the support beams (along the longitudinal central axis of the device). As a result, the valve device of the present invention acquires greater durability and is capable of withstanding the harsh conditions prevailing within the vasculature and especially the millions of cycles of stress applied by the blood pressure.

**[0126]** The fixed attachment of the valve leaflets to the support frame in the valve assembly device of the present invention renders it greater stability, enhanced safety, better sealing and consequently longer lifespan. The novel design of the valve device of the present invention

renders it longitudinal strength and rigidity whereas its collapsible support structure renders it radial flexibility.

**[0127]** Figures 25a to 25d illustrate an implantable prosthetic valve. Figures 25a and 25b depict an isometric view and an upper view of the valve assembly, respectively and Figures 25c and 25d illustrate upper views of two optional constructions for the means for mounting leaflets. Pericardial leaflets 430 are mounted on a deployable support frame 432. The frame is preferably made of three segments that form a circular support frame when assembled (Figure 25b). Pericardial leaflets 430 are attached to deployable support frame 432 along three substantially equidistant and substantially parallel beams 440, which are integral parts of support frame 432. Leaflets 430 are attached to support frame 32 at support beams 440 by suturing 446 leaflets 446 to support beams 440 through bores 442 in beams. The frame segments that are preferably made from stainless steel are pre-shaped 432 and can be formed in different ways. Figure 25c illustrates support frame segments 432a having beams 435a pointing inwardly. Figure 25d illustrates support frame segments 432b having beams 435b that are outwardly pointing. The advantages of this technique are the possibility to manufacture the frame segments from sheets (as opposed to tube) and the ease of assembly of the frame segments with the pericardial leaflets.

**[0128]** Figures 26a to 26c illustrate a tricuspid valve provided with a self-expandable frame. Figure 26a is an isometric view of an implantable prosthetic valve 430 mounted on a self-expandable frame 445. Implantable prosthetic valve 430 comprised of three valve leaflets is mounted on self-expandable frame 445 so that each leaflet extends along an equidistant portion of the frame and is sutured at both opposite sides to substantially equidistant and substantially parallel beams 440. By using a tapered tube 448 the whole assembly is crimped into a restriction tube 449. Figure 26b shows the crimped valve assembly 447 in its final crimped diameter ready for insertion to the body. After insertion into the desired location in the body the valve is released from the restriction tube and as it is made of self expandable material (like a shape-memory alloy), it expands back to the original diameter and is anchored in place. In order to reduce the diameter of the device from its fully expanded diameter to its crimped diameter a special tapered tube is used, shown in Figure 26c.

**[0129]** Figure 27 illustrates an isometric view of an implantable prosthetic valve having hooks designated to anchor the valve assembly to body ducts. An implantable prosthetic valve 450 is placed in a natural aortic valve position 452. Implantable prosthetic valve 450 comprises preferably three leaflets 430 mounted on a metallic support frame 455. The lower part of support frame 455 is provided with attachment means, preferably with hooks 453. Hooks 453 assures that the valve assembly stays in place after deployment, and cannot migrate to another position.

**[0130]** Figure 28 illustrates a partial view of an implantable prosthetic valve. The commissural attachment is shown in details. This figure demonstrates an attachment technique that is used in order to attach pericardium leaflet 430 to a metallic frame 420. A longitudinal bar 456 having a narrow slit 457 is used as the commissural attachment so that extensions 463 of pericardium leaflet 430 are tightly inserted through slit 457. Pericardium extensions 463 that are extended beyond slit 457 are wrapped about a rigid bar 458 that acts as an anchoring means. Every two extensions originating from two sides of slit 457 are sutured to each other by a suture 459 at the side of rigid bar 458 opposite the slit. An additional suture 462 attaches the bottom circumference of support frame 420 to leaflet 420 in order to obtain sealing. The advantages of the described attachment are that no sutures or suture holes are applied in the leaflet working area, there are no concentrated stress points similar to stress point caused by suturing, and the force distribution is along the longitudinal bar 456. The narrow passage that is maintained through slit 457 forces the leaflets to be static in respect to the support so as to reduce abrasion.

**[0131]** The embodiments that will be shown herein after are optional configurations of attachment between the leaflets and the support frame.

**[0132]** Figures 29a and 29b illustrate an isometric view and an upper cross sectional view, respectively, of an attachment assembly of a valve's frame to leaflets. The attachment is similar in principle to the attachment shown in Figure 28, however, longitudinal bar 456 is further provided with an additional pole 465 that is attached to longitudinal bar 456 so as to establish an integral part. Pole 465 is rounded so as to make sure the leaflets will not be abraded or cut by sharp corners. In the cross sectional view shown in Figure 29b, adjacent leaflets 460 can be seen compressed together and the main protection goal is clearly shown.

**[0133]** Figures 30a to 30c illustrate an isometric view, a cross-sectional view and a flatten view, respectively, of an attachment assembly of a valves frame to leaflets. Using the method demonstrated in Figures 30a to 30c, the pericardial leaflets are pre-cut to the desired shape 430 and are provided with longitudinal bars 470 that are sutured to the leaflets creating a longitudinal clamping effect (Figure 30c). This allows distribution of forces along the whole length of the attachment means as opposed to concentrating the stresses in suture holes. In Figures 30a and 30b, an additional rigid portion 458 is added, creating a round ending, which prevents the leaflets from being bent drastically at the attachment point to portions of the frame 420. The attachment to frame 420 is performed using sutures 459.

**[0134]** Figures 31a and 31b illustrate an exploded view and an isometric view, respectively, of a commissural attachment depicting the attachment technique. A method of assembling pericardial leaflets 430 to a frame 420 is demonstrated. A rigid bar 476 provided with integral

protrusions 478 is inserted through bores 479 that are pre-cut in pericardial leaflets 430. Integral protrusions 478 pass through a sheet of preferably PET (braided polyester) fabric 475, and finally through bores 442 that are provided in longitudinal bar 440 (the attachment means) of frame 420. After the assembling of the parts, as shown in Figure 31b, the parts are tightly assembled and bar protrusions 478 are attached to bar 440 by welding, riveting or any other technique. The PET sheet 475 is folded and sutured tightly around bar 476 using suture 472.

**[0135]** Figures 32a to 32c illustrate an isometric view of an attachment between leaflets and the frame. An optional method of attachment is demonstrated, in which a pericardium leaflet 430 and bars 480 are sutured in an area far as possible from the working area of the leaflets. The pericardium is first sutured using a suture 484 to bar 480 as seen in Figure 32b, and then folded and compressed. In order to firmly hold the pericardial leaflets in place between bars 480, an integral connecting member 482 connects the two bars, allowing the bent portions of the bars to be in parallel position, with the leaflets caught in between. Then, an additional suture 483 connects the bottom side of the bar to the leaflets so that while the valve is working, the leaflets do not bear high stresses.

**[0136]** Figures 33a to 33d illustrate different views of portions of an attachment between a pericardium and a frame demonstrating another method of attachment. A connecting member 490 (shown in a deployed position in Figure 33d) is used to connect two pericardial leaflets 492 at the line of the commissure. After being connected between them, pericardial leaflets 492 are being connected to frame bar 480. Here again, the principal of compressing the leaflets between two bent portions bars 491 of connecting member 490 and tightening them using suture 484 without punctures in the working areas of the pericardium is applied. However, connecting member 490 is provided with a portion 493 that is positioned perpendicular to the two bent portions bars 491 that holds the two leaflets together. Portion 493 is the connecting member to frame's bar 480. In Figure 33a, the junction point 495 between the portions of connecting member 491 is placed at the upper part (outlet) of the frame so as to achieve a rigid connection to the frame. In Figure 33b, junction point 495 is placed at the bottom part (inlet) of the frame so that the junction point also functions as a spring. Comprehensive explanation of the benefits of springs in commissures is discussed and shown in respect with Figures 37 to 39.

**[0137]** Figures 34a to 34c illustrate an isometric view of an attachment between a pericardium and a valve demonstrating another method of attachment. In Figures 34b and 34c, a deployed portion and the folded portion, respectively, are shown. An optional design for the attachment between the frame and the leaflets is depicted. A connecting member 480 (shown clearly in Figure 34b) is being produced into a flat configuration using laser-cutting. Connecting member 480, which is a part of the frame's attachment means, is bent and then is ready for

assembly with the leaflets. Connecting member 480 comprises the main body as well as a connection bar 497 and a flexible element 498 allowing flexibility to the commissural. Leaflets 430 are threaded through corresponding holes 481 in the structured connecting member 480 and are sutured using a suture 482.

**[0138]** Reference is now made to Figures 35a, 35b, and 35c illustrating isometric and cross-sectional upper views, respectively, of attachment techniques between a pericardium leaflet and a valve's frame. Figures 35b and 35c depict different techniques of commissural attachments: in Figure 35b two pieces of pericardial leaflets 500 are wrapped around a metallic member 505 that is connected to a frame 501. Rigid members 503 are positioned from both sides of metallic member 505 and then tightened together and connected by a suture 502. All metallic pieces are wrapped by PET fabric 508 in order to avoid direct contact between the metallic pieces and the delicate pericardial leaflets. The advantage of this structure is that after tightening the suture, the whole commissure becomes static with no relative movement between the portions. This improves the valve assembly's resistance to abrasion. In addition, there are no needle holes or sutures in the working area. Figure 35c depicts a similar structure, however, there is no use of rigid sidebars. After wrapping the metallic member 505 with pericardial leaflets 500, a piece of PET 508 is used for tightening it to a tight bundle. In this case, the suture line 502 is the borderline of the working area so it should be designed so that stresses are in the best possible distribution.

**[0139]** Figures 36a and 36b focus on the connection of the commissural assembly to frame's protrusion 509, which is an integral part of the frame and is the basis for the commissural attachment. This example shows the use of four rigid longitudinal bars 503 connected by a suture 502.

**[0140]** Figures 37a to 37c illustrate a commissural assembly where the connecting bar functions as a flexible support and has integral attachment means to the frame. Figure 37b is an isometric view of the connecting bar. Connecting bar 520 is flexible and comprises a resilient material shaped in a "U" shape. Connecting bar 520 is a part of commissural assembly 527 shown in Figure 37a. Connecting bar 520 is provided with protruding elements 521 that are acting as the means of attachment to the frame's bar 480. Protruding elements are designated to be inserted in corresponding bores 442 in bar 480. It is optional to provide rods 527 which are integral parts of the "U" shaped member and replace the suture 526 that connects the pericardium leaflet and the connecting bar together, which is shown in Figure 37a. Figure 37c depicts another method of attaching the flexible connecting bar 520 to the frame 480 by means of welding 523. Here the pericardial leaflets 500 are attached to the connecting bar 520 by suture 526 inserted through a PET fabric 508 and two connecting bars 503, which together create a tight bundle.



**[0141]** Figures 38a to 38g illustrate isometric views of flexible commissural supports and the method of attaching them to a pericardium and a frame or valve. Figures 38a to 38c demonstrate incorporation of different design options of commissural springs. The main purpose of a commissural spring is to reduce the impact applied to the pericardial leaflets when the valves leaflets are closed. If the structure is of a rigid nature, high stress will be applied each time the valve closes. If a spring is added to the structure, the spring will bear the highest portion of the impact, thus reducing the stress applied to the leaflets during the time the valve is closed. In Figure 38a, a simple stainless steel spring 530 is connected to frame's bar 480 by threading a portion of the spring into slot tabs 538 as shown in more detail in Figures 38e and 38f. In Figure 38b, there is a similar spring 530 with leaflets 500 connected to it by one of the attachment methods, the commissural support itself 530 is connected to the frame's bar 480 by spot welding, laser welding or other attachment means. Figure 38c depicts a similar spring 534 having an additional spiral. The purpose of such a spiral is to reduce stress in the spring and to allow the fatigue requirements, which in the case of heart valves are of at least 200 million cycles.

**[0142]** Figure 38d illustrates an isometric view of a flexible commissural support demonstrating the attachment of the pericardium to the support. Figures 38e to 38g are the details of the attachment to the frame. A commissural spring of a different design 539 comprises a stainless steel wire of a small diameter in respect with the springs described in Figures 38a to 38c. One advantage of this structure is the distribution of stresses in the spring and the ability to form a structure, which can be crimped to a small diameter. Another advantage in this structure is that there are no open edges of the spring, which can be dangerous when operated; the open edges are protected in the frame's bar as shown in Figures 38e to 38g, which show possible attachment methods of the spring to the frame. In Figure 38e, a frame's flat bar 480 has slots 531 cut to form slot tabs 538 for crimping the spring 530. Figure 38f shows pre-bending of the slots 527 and Figure 38g shows the spring legs 539 assembled firmly into the slot tabs 538.

**[0143]** Figure 39a illustrates a technique of commissural assembly using a shaped compressing member 511. The compression member 511 holds pericardial leaflets 500 firmly while pressing it in the pivot points 513. A radial edge 514 is made in order to protect the pericardium from abrasion. The whole assembly is held tightly inside the compressing member 516. The commissural assembly is connected to the frame by protrusion member 518, which fit bores in the frames bar 480. Figure 39b is an isometric view of the same detail.

**[0144]** Figures 40a to 40c illustrate an isometric view of a bicuspid valve mounted on a frame. Figures 40b and 40c depict a cross-sectional side view and an isometric view, respectively, of the pericardium that is sutured to a PET tube in the form of pockets. The valve assembly

(in this case bicuspid) comprises a crimpable frame 540, two pericardial leaflets 545, a PET skirt 543 and a connecting suture 547. The focus in this drawing is on the pocket shape of the pericardium leaflet shown best in Figures 40b and 40c. One of the main goals in valve design, in general, is to distribute the stresses in a homogenous way in the pericardium material and the attachment areas. The design of the pericardium leaflet as a pocket assists in distributing the stresses along suture line 547; pericardium leaflet 545 is sutured to PET skirt 543 along connecting suture 547. PET skirt 543 is sutured to the circumference of crimpable frame 540 at the bottom side 549 and at the top 542 using one of the commissural attachments that are described herein before regarding other embodiments. When hydrodynamic pressure is applied on leaflets 545, the leaflets will meet in the center 546 of frame 540 so as to seal the valve assembly. The shape of the leaflets in the valve assembly is determined by the boundary conditions, which in this case are the suture lines. The suture lines can be designed to have an optimal shape regarding the stress distribution in accordance with geometrical restrictions.

**[0145]** Reference is now made to Figures 41a to 41d illustrating isometric views of an implantable prosthesis tricuspid valve. Figure 41a illustrates valve assembly 553 in an open state. Valve assembly 553 comprises a frame 555 (rigid or crimpable), pericardial leaflets 550 and bars 551. It is emphasized that in the shown embodiment, the goal is to distribute the stresses on the commissural arrangement in an optimal way. Pericardial leaflets 550 are attached to bars 551 that act as attachment means. The attachment means are positioned at the top third of the valve; the bottom circumference is attached to the frame in order to obtain full sealing. The middle part of the pericardium is left slack. The pre-cut pericardium is cut in greater dimensions than the frame; e.g., the height of the pericardium leaflet is greater than the height of the frame, for example, if the frame height is 15 mm, the pericardium will be cut to a height of 18 mm so as to establish a slack portion in the middle area of the valve assembly 553. Figure 41b depicts the valve assembly in a closed state. The slack portion of the pericardium collapses toward the middle while creating a small pocket shape 554, which assists in the stress distribution. Figure 41c shows the detailed commissural and the short bar attachment as well as the circumference sealing area at the bottom portion of the pericardium assembly. It is shown in the figures that bars 551, which are relatively short, allow firm attachment of the top portion of the commissural, slack portion in the middle, and a good sealing surface at the bottom portion 556.

**[0146]** Reference is now made to Figures 42a and 42b illustrating an isometric view of an implantable prosthetic valve having a different commissural attachment. Figure 42b depicts the attachment in details. In the valve shown in Figure 42a, similar valve assembly is illustrated, while the short bar is arranged in a manner that is similar to the structure shown in Figure 28 and described herein

before. Relatively short bars 559 act as the attachment means to the frame bar 558. Suture 557 attaches short bars 559 to a member 558, the suture can be made from an elastic material so that to add flexibility to the commissures and to render the valve assembly the benefits already explained herein.

**[0147]** Reference is now made to Figures 43a and 43b illustrating an isometric view of an implantable prosthetic valve. Figure 43a depicts commissures that are pre-sutured in a tapered shape. The valve assembly shown in Figure 43a comprises a frame 560, pericardial leaflets 563, and attachment means 561. Pericardial leaflets 563 are shown to be in an open state so as to establish an open valve assembly while dashed lines 565 show the valve in a closed sealed state. The attachment to the commissures can be performed using one of the explained techniques. Specifically to the valve shown in Figures 43a and 43b, the focus is on the formation of a tapered valve in which the attachment means is in the shape of long bars 561 that are attached to the pericardium in an angular way in apposition to the parallel attachment. Attaching the bars in an angular way when the pericardium is flattened will create a tapered tube when built up to the three dimensional shape. When the whole prosthetic valve is inflated by a balloon, the pericardium leaflet, at the top circumference of the frame, is stretched and the frame is expanded to the full diameter. After deflating the balloon, the frame stays in its expended size but the pericardial leaflets regains their pre-stretched shape. This process creates a permanent clearance distance 562 between the pericardial leaflets 563 and frame 560. This is of major importance in the protection of the pericardium from abrading against the frame.

**[0148]** Reference is now made to Figures 44a to 44c illustrating an isometric view of an implantable prosthetic valve with additional pieces of PET used for sealing and protecting the pericardium. The illustrated implantable valve assembly resembles the valve shown in Figure 43, however, it is emphasized that in the attachment of the pericardial leaflets 570 to frame 575, there is use of PET. Figure 44c shows in a cross-sectional view, the way the PET is assembled to the pericardium and the frame in a manner that protects the pericardium against wear. PET 571 and 572 are used for connecting pericardial leaflets 570 to frame 575, while they are assembled in between the leaflets and the frame. A suture 577 connects pericardium leaflet 570 in between two layers of PET, while the inner layer of PET 572 is short and the outer layer is longer. Bottom attachment suture 576, connects the three layers, the leaflet and both PET layers to the frame and forms a strong sealing line. An upper suture 578 connects the outer PET layer 571 to frame 575. When the valve assembly closes and the pericardial leaflets come closer to each other at the top of the assembly, there is a tendency of the bottom attachment to move and rotate about an attachment point 577. Upper suture line 578 keeps the outer PET layer tight and prevents a part of this rotational movement, which can rapidly cause

an abrasion failure.

**[0149]** Figures 45a to 45d illustrate an isometric view of an implantable prosthetic valve having leaflets sutured to a pre-shaped PET tube and optional leaflet-tube attachments in details. A novel technique of mounting pericardial leaflets 580 to a pre shaped PET tube 585 is shown. The tube is shaped so as to have a folding 586 with substantially sinusoid pattern 586 that is similar to the optimal connection line of valve leaflets in the natural valve. This shape allows the pericardial leaflets to be sutured to the interior of the PET tube. The preferred suturing techniques are shown in the cross sectional views of PET tubes in Figures 45b, 45c, and 45d. Generally, in order to protect the pericardial leaflets from tearing, an additional piece 583 of PET is added below the suture lines. Similar variations are shown in Figures 45c and 45d.

**[0150]** Reference is now made to Figure 46a illustrating an exploded view of an implantable prosthetic valve assembly where the leaflets are mounted on a pre-cut and pre-shaped tube and the outlet of the valve is cut in a commissural shape. Figure 46a is view of the attachment. A pre-shaped PET tube 590 is cut to have substantially sinusoidal shape 596 and then bent in order to provide a suturing area. The pericardium leaflet 593 is pre-cut and assembled to PET tube 590 by means of suturing 502. In this case as well as in the former case, an additional protective layer of PET or pericardium 594 is added. Figure 46b is a cross-section of the attachment detail after being tightened

**[0151]** Figures 47a to 47c illustrate a partial cross-sectional side view of an inflating balloon. The balloon is a part of an implantable prosthetic valve delivery system. Figures 47b and 47c are cross sectional upper views in the inflated and deflated positions, respectively. The specially designed balloon shown in the figures preferably comprises four inflating members, three substantially identical and symmetrical sections 600 and a central section 602. Pericardial leaflets 612 are positioned between sections 600 and separate them. A frame 610 circles the inflating members and a balloon shaft 619 that is positioned in the center of the delivery system while a commissural connection 613 connects pericardial leaflets 612 to frame 610. The inflated balloon sections 600 are placed between frame 610 and pericardial leaflets 612 so that when the inflating members are inflated, they push leaflets 612 toward each other and frame 610 so as to establish a fully closed position. This technique better preserves the leaflets since there is no contact between the leaflets and the frame besides in the commissural connection. The preservation of the leaflets is even improved in times of inflation as well as after inflating the valve and establishing a closed position. In Figure 47a the fourth inflating member of the balloon, central section 602 is clearly shown. Through central section 602, the inlet 617 of the valve is inflated while the inflated central section assures that the whole valve is fully inflated to substantially round shape. Figure 47c shows the assem-

bly in a crimped position. Frame 610 is crimped and sections 600 are deflated. Pericardial leaflets 612 are also shown in a crimped configuration.

**[0152]** Figures 48a and 48b illustrate a partial cross-sectional side view and an upper cross sectional view of an inflating balloon. The inflating balloon comprises of a central inflating balloon 620 and three protection sheets 622. In the lateral cross-section shown in Figure 48b, the parts of inflated assembly 625 are clearly shown, protection sheets 622 protects the pericardial leaflets 624 from being pushed against the frame 625 when the device is inflated. The advantage of this arrangement is in the protection of the pericardial leaflets.

**[0153]** The preferred embodiments representing an implantable prosthetic valve in accordance with the present invention are relatively easy to manufacture as they are generally flat throughout most of the production process and only at the final stage of mounting the other elements of the valve assembly on the support frame, a three dimensional form is established.

**[0154]** A typical size of an aortic prosthetic valve is from about 19 to about 25 mm in diameter. A maximal size of a catheter inserted into the femoral artery should be no more than 8 mm in diameter. The present invention introduces a device, which has the ability to change its diameter from about 4 mm to about 25 mm. Artificial valves are not new; however, artificial valves in accordance with the present invention possess the ability to change shape and size for the purpose of delivery and as such are novel. These newly designed valves require new manufacturing methods and technical inventions and improvements, some of which were described herein.

**[0155]** As mentioned earlier, the material of which the valve is made from can be either biological or artificial. In any case new technologies are needed to create such a valve.

**[0156]** To attach the valve to the body, the blood vessels determine the size during delivery, and the requirements for it to work efficiently, there is a need to mount it on a collapsible construction which can be crimped to a small size, be expanded to a larger size, and be strong enough to act as a support for the valve function. This construction, which is in somewhat similar to a large "stent", can be made of different materials such as Nitinol, biocompatible stainless steel, polymeric material or a combination of all. Special requirement for the stent are a subject of some of the embodiments discussed herein.

**[0157]** The mounting of the valve onto a collapsible stent is a new field of problems. New solutions to this problem are described herein.

**[0158]** Another major aspect of the design of the valve of the present invention is the attachment to the body.

**[0159]** In the traditional procedure the valve is sutured in place by a complicated suturing procedure. In the case of the percutaneous procedure there is no direct access to the implantation site therefore different attachment techniques are needed.

**[0160]** Another new problem that is dealt herein is the delivery procedure, which is new and unique. Positioning of the device in the body in an accurate location and orientation requires special marking and measuring methods of the device and surgical site as was disclosed herein.

**[0161]** Artificial polymer valves require special treatment and special conditions when kept on a shelf, as well as a special sterilization procedure. One of the consequences of the shelf treatment is the need to crimp the valve during the implantation procedure. A series of devices and inventions to allow the crimping procedure are disclosed herein.

**[0162]** It should be clear that the description of the embodiments and attached Figures set forth in this specification serves only for a better understanding of the invention, without limiting its scope as covered by the following claims.

**[0163]** It should also be clear that a person skilled in the art, after reading the present specification could make adjustments or amendments to the attached Figures and above described embodiments that would still be covered by the following claims.

## Claims

1. A valve prosthesis device (20) suitable for implantation in body ducts, the device comprising:

an expandable support frame (22) comprising a deployable construction adapted to be initially crimped in a narrow configuration suitable for catheterization through the body duct to a target location and adapted to be deployed by exerting substantially radial forces from within by means of a deployment device to a deployed state in the target location, the support frame being provided with a plurality of longitudinally rigid support beams (23) of fixed length; and a valve assembly (28) comprising a flexible conduit having an inlet (24) and an outlet (26), made of pliant material (29) attached to the support beams (23) providing collapsible slack portions of the conduit at the outlet (26), whereby when flow is allowed to pass through the valve prosthesis device (20) from the inlet (24) to the outlet (26) the valve assembly (28) is kept in an open position, whereas a reverse flow is prevented as the collapsible slack portions of the valve assembly (28) collapse inwardly providing blockage to the reverse flow, characterized in that the support beams (23) are provided with bores (25, 42) and the valve assembly (28) is stitched to the support beams (23) with thread or fiber (46) through the bores (25, 42).

2. The prosthetic device of Claim 1, wherein the inlet (24) of the valve assembly (28) is attached to the support frame (22).
3. The prosthetic device of Claim 1, wherein the pliant material (29) is provided with longitudinal bars attached to the pliant material at positions assigned for attachment to the support frame (22), in order to prevent localized stress from forming.
4. The prosthetic device of Claim 1, wherein the pliant material is sutured leaving the slack portions free of sutures.
5. The prosthetic device of Claim 1, wherein the outlet (26) is tapered with respect to the inlet (24).
6. The prosthetic device of Claim 5, wherein the support frame (22) at the outlet (26) is wider in diameter than the pliant material (29) forming the outlet (26).
7. The prosthetic device of Claim 1, wherein the pliant material (29) is reinforced using PET.
8. The prosthetic device of Claim 1, wherein the device is incorporated with an angioplasty balloon.
9. The prosthetic device of Claim 8, wherein the balloon has a central longitudinal axis that runs along a flow path through the device, and a perimeter, the balloon comprising four inflatable portions, one portion located along a central axis and the other three located on the perimeter, the pliant material in the form of leaflets is distributed about the perimeter.
- Patentansprüche**
1. Klappenprothesevorrichtung (20), die für die Implantation in Körpergängen geeignet ist, wobei die Vorrichtung umfasst:
- einen ausdehnbaren Stützrahmen (22), der einen einsetzbaren Aufbau umfasst, der geeignet ist, anfänglich zu einem schmalen Aufbau gefaltet zu werden, der zur Katheterisierung durch den Körpergang zu einem Zielort geeignet ist und geeignet ist, mit Hilfe einer Einsetzvorrichtung durch Ausüben von im Wesentlichen radialen Kräften von innen in einen eingesetzten Zustand an dem Zielort eingesetzt zu werden, wobei der Stützrahmen mit mehreren in Längsrichtung steifen Trägern (23) fester Länge versehen ist; wobei der Stützrahmen mit mehreren der Länge nach steifen Trägern (23) fester Länge versehen sind; und eine Klappenanordnung (28), die einen flexiblen Kanal mit einem Einlass (24) und einem Auslass (26) aufweist, die aus nachgiebigem Material (29) besteht, das an den Trägern (23) angebracht ist, die zusammenklappbare entspannte Abschnitte des Kanals an dem Auslass (26) bereitstellen, wobei die Klappenanordnung (28), wenn zugelassen wird, dass eine Strömung von dem Einlass (24) durch die Klappenprothesevorrichtung (20) zu dem Auslass (26) strömt, in einer offenen Position gehalten wird, während die Rückwärtsströmung verhindert wird, da die zusammenklappbaren entspannten Abschnitte der Klappenanordnung (28) nach innen zuklappen und eine Sperrung für die Rückströmung bereitstellen, **dadurch gekennzeichnet, dass** die Träger (23) mit Bohrungen (25, 42) versehen sind, und die Klappenanordnung (28) durch die Bohrungen (25, 42) mit Garn oder Faden mit den Trägern (23) vernäht ist.
2. Prothesevorrichtung nach Anspruch 1, wobei der Einlass (24) der Klappenanordnung (28) an dem Stützrahmen (22) angebracht ist.
3. Prothesevorrichtung nach Anspruch 1, wobei das nachgiebige Material (29) mit Längsstangen versehen ist, die an Positionen an dem nachgiebigen Material angebracht sind, die für die Befestigung an dem Trägerrahmen (22) zugewiesen sind, um zu verhindern, dass sich eine lokalisierte Belastung bildet.
4. Prothesevorrichtung nach Anspruch 1, wobei das nachgiebige Material vernäht ist, wobei die entspannten Abschnitte frei von Nähten gelassen sind.
5. Prothesevorrichtung nach Anspruch 1, wobei der Auslass (26) in Bezug auf den Einlass (24) konisch zuläuft.
6. Prothesevorrichtung nach Anspruch 5, wobei der Durchmesser des Stützrahmens (22) an dem Auslass (26) breiter als das nachgiebige Material (29) ist, das den Auslass (26) bildet.
7. Prothesevorrichtung nach Anspruch 1, wobei das nachgiebige Material (29) unter Verwendung von PET verstärkt ist.
8. Prothesevorrichtung nach Anspruch 1, wobei die Vorrichtung einen Angioplastieballon eingebaut hat.
9. Prothesevorrichtung nach Anspruch 8, wobei der Ballon eine Mittellängsachse, die entlang eines Strömungswegs durch die Vorrichtung verläuft, und einen Umfang hat, wobei der Ballon vier aufblasbare

Abschnitte umfasst, einen Abschnitt, der sich entlang einer Mittelachse befindet, und die anderen drei, die sich auf dem Umfang befinden, wobei das nachgiebige Material in der Form von Blättchen um den Umfang herum verteilt ist.

#### Revendications

1. Un dispositif de valve prothétique (20) adapté à une implantation dans des conduits corporels, le dispositif comprenant :

une armature de support extensible (22) comprenant une construction déployable adaptée pour être initialement rétréci dans une configuration étroite adaptée en vue d'une cathétérisation à travers le conduit corporel vers un site cible et adapté pour être déployée en exerçant des forces substantiellement radiales à partir de l'intérieur au moyen d'un dispositif de déploiement vers un état déployé dans le site cible, l'armature de support étant dotée d'une pluralité de montants de soutien rigides longitudinaux (23) de longueur fixe, et

un ensemble de valve (28) comprenant un conduit flexible ayant une entrée (24) et une sortie (26), constitué d'un matériau malléable (29) attaché aux montants de soutien (23) fournissant des portions flasques affaissantes du conduit à la sortie (26),

par lequel, lorsqu'un flux est amené à passer à travers le dispositif de valve prothétique (20) de l'entrée (24) vers la sortie (26), l'ensemble de valve est maintenu dans une position ouverte, tandis qu'un flux inverse est empêché du fait que les portions flasques affaissantes de l'ensemble de valve (28) se replient vers l'intérieur, provoquant ainsi un blocage du flux inverse,

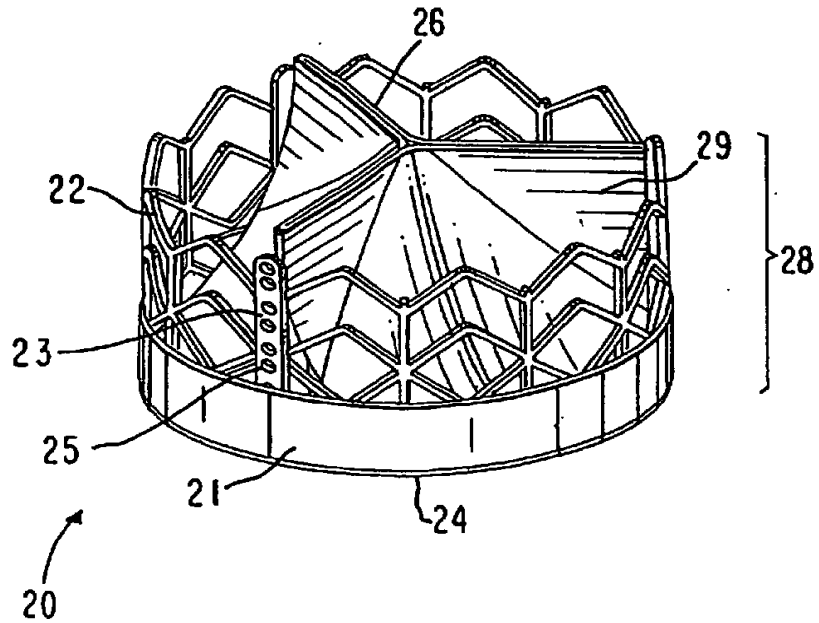
**caractérisé en ce que** les montants de soutien (23) sont pourvus de perforations (25, 42) et l'ensemble de valve (28) est cousu aux montants de soutien (23) à l'aide de fil ou de fibre (46) à travers les perforations (25, 42).

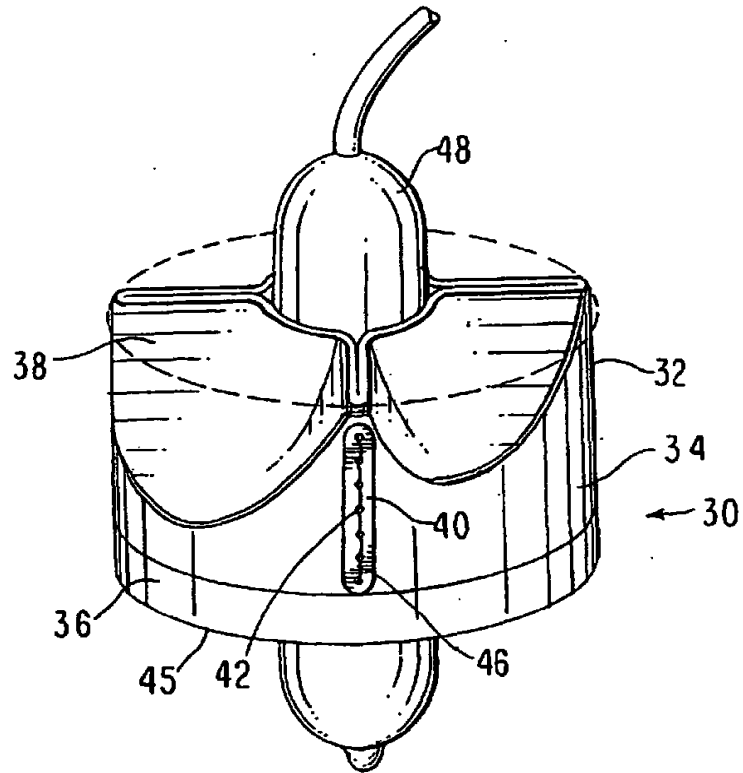
2. Le dispositif prothétique de la revendication 1, dans lequel l'entrée (24) de l'ensemble de valve (28) est attachée à l'armature de support (22).
3. Le dispositif prothétique de la revendication 1, dans lequel le matériau malléable (29) est pourvu de barres longitudinales attachées au matériau malléable à des positions assignées à la fixation à l'armature de support (22), afin d'empêcher la formation d'une contrainte localisée.
4. Le dispositif prothétique de la revendication 1, dans lequel le matériau malléable est suturé, les portions

flasques étant laissées libres de sutures.

5. Le dispositif prothétique de la revendication 1, dans lequel la sortie (26) est fuselée par rapport à l'entrée (24).
6. Le dispositif prothétique de la revendication 5, dans lequel l'armature de support (22) à la sortie (26) est plus grande en diamètre que le matériau malléable (29) formant la sortie (26).
7. Le dispositif prothétique de la revendication 1, dans lequel le matériau malléable (29) est renforcé au moyen de PET.
8. Le dispositif prothétique de la revendication 1, dans lequel le dispositif est intégré à un ballon d'angioplastie.
9. Le dispositif prothétique de la revendication 8, dans lequel le ballon a un axe longitudinal central qui s'étend le long d'une trajectoire de passage à travers le dispositif, et un périmètre, le ballon comprenant quatre portions gonflables, une portion située le long d'un axe central et les trois autres situées sur le périmètre, le matériau malléable sous forme de folioles est distribué autour du périmètre.

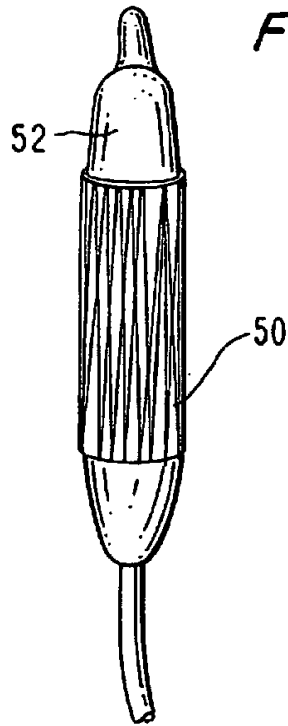
*FIG. 1*



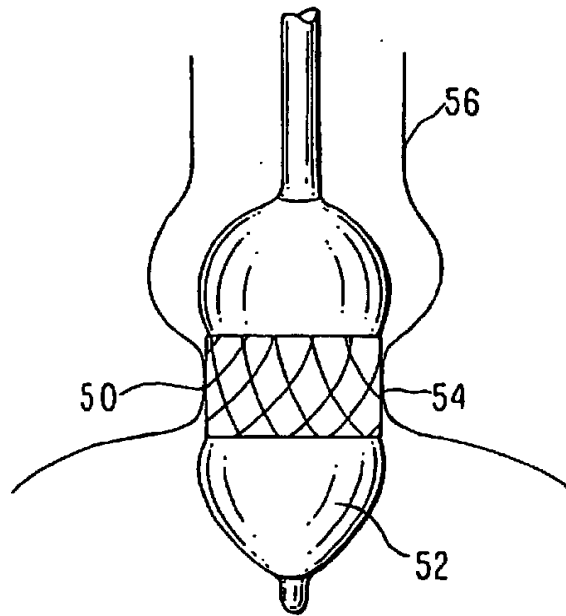


**FIG. 2**

**FIG. 3**

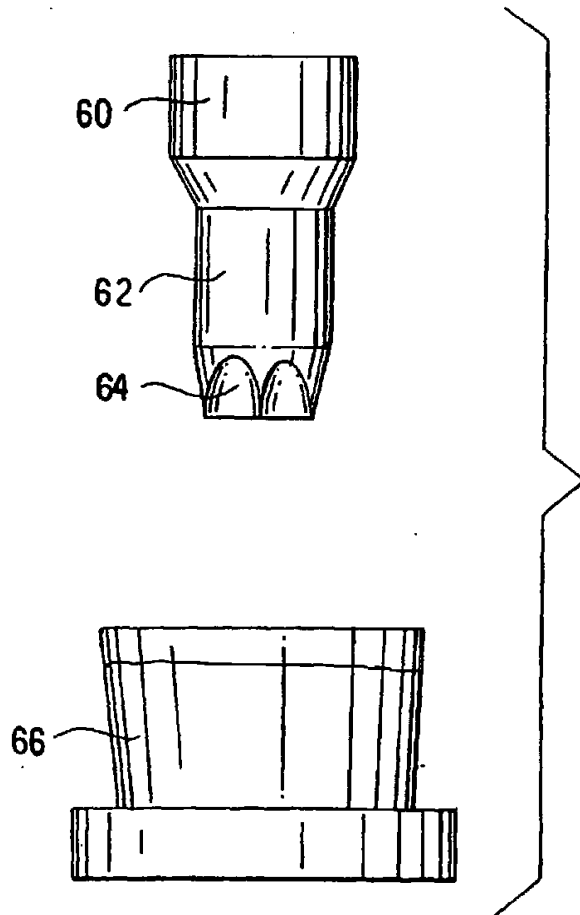


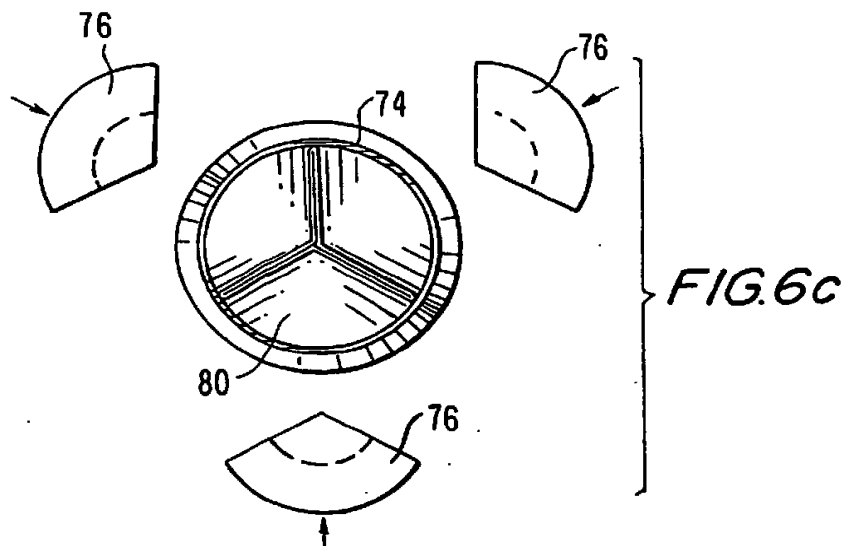
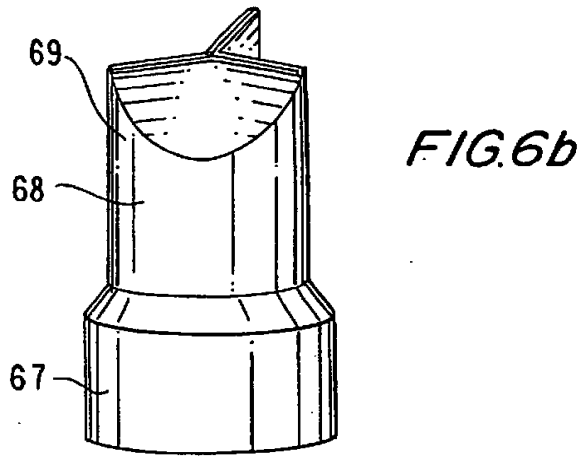
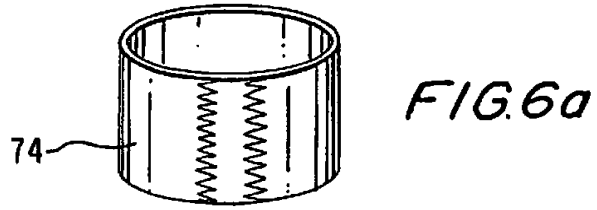
**FIG. 4**



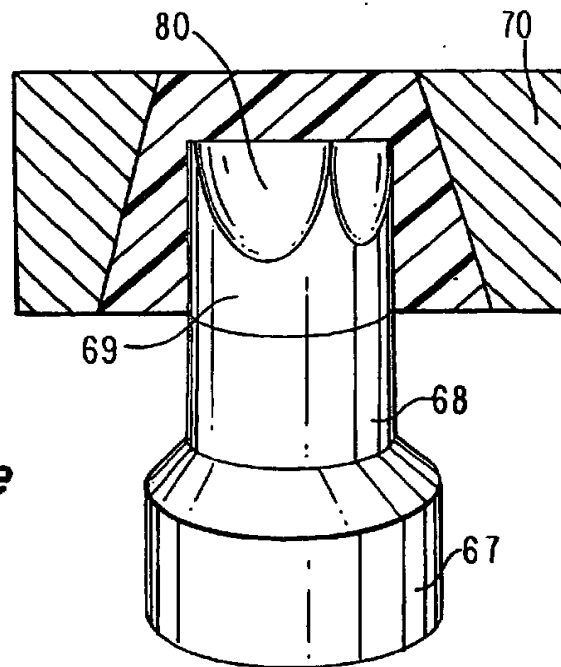
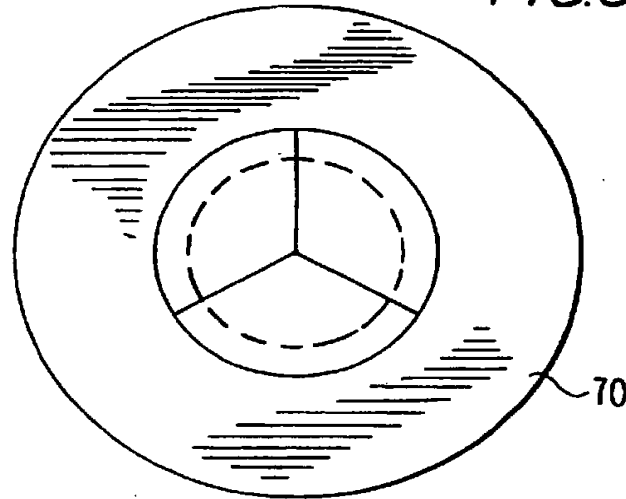


*FIG. 5*

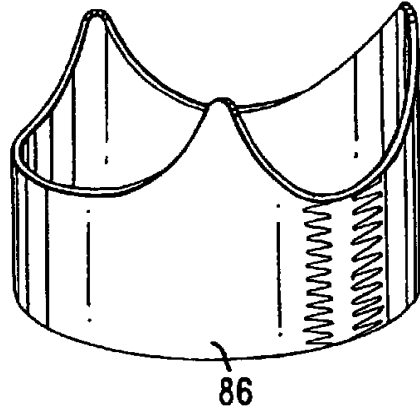




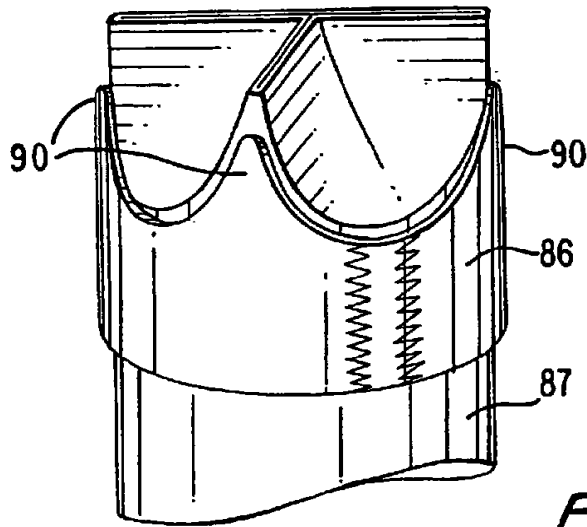
*FIG.6d*



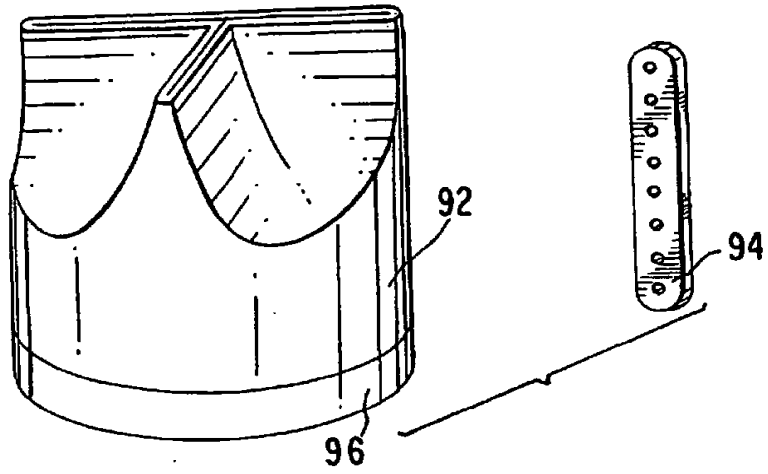
*FIG.6e*



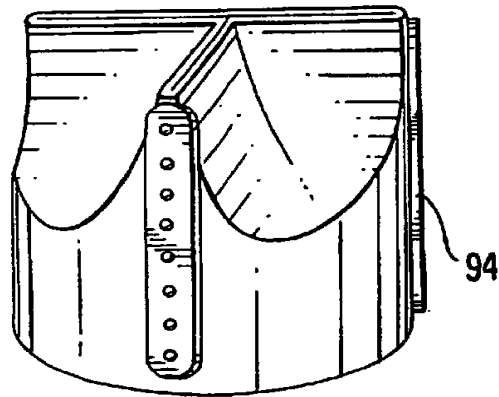
*FIG. 7a*



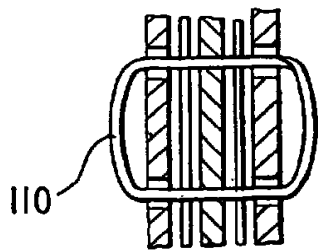
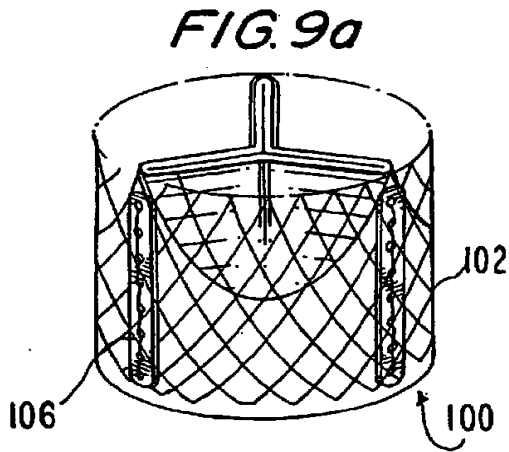
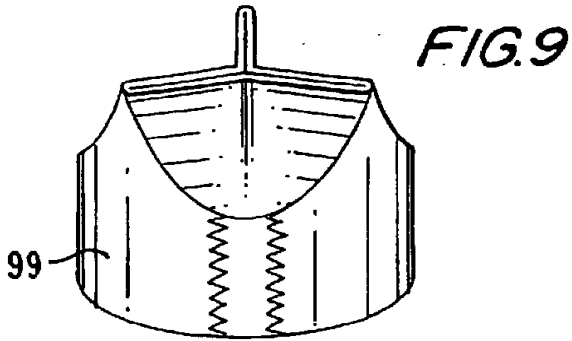
*FIG. 7b*



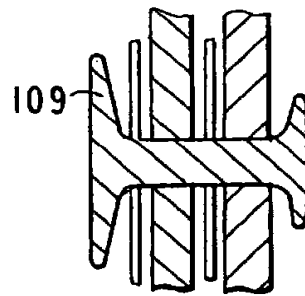
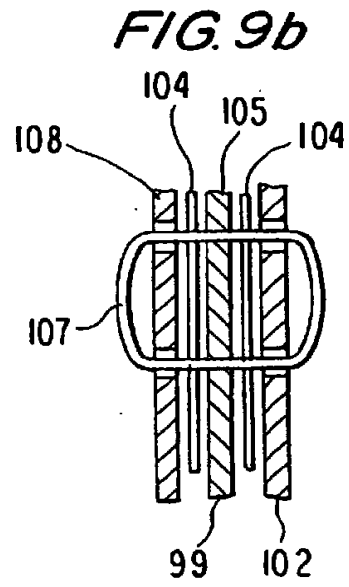
*FIG. 8a*



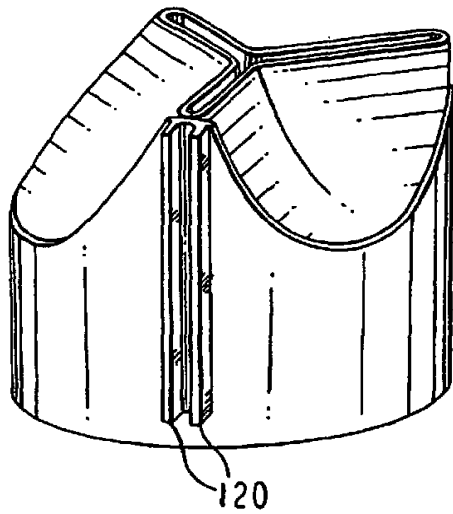
*FIG. 8b*



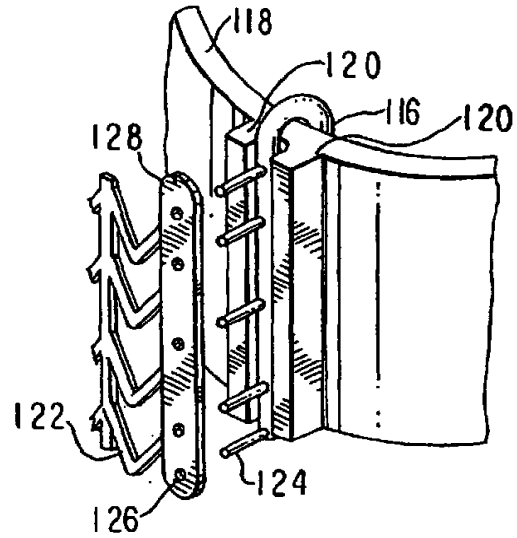
**FIG. 9d**



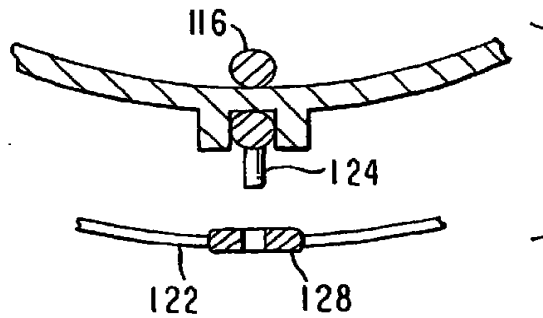
**FIG. 9c**



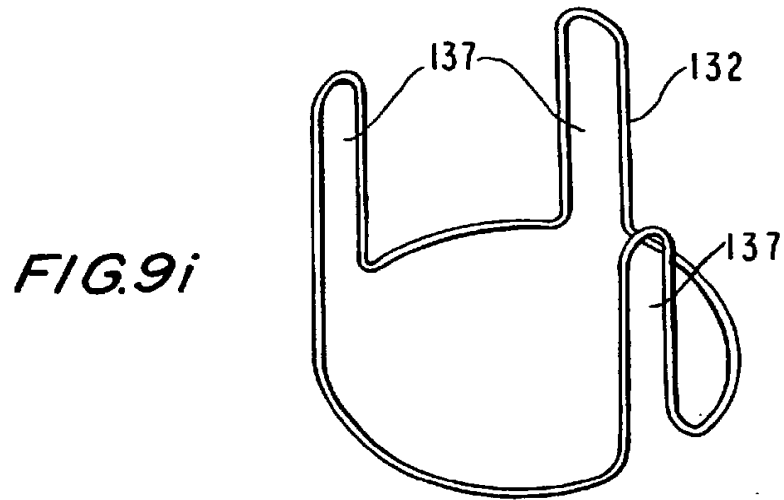
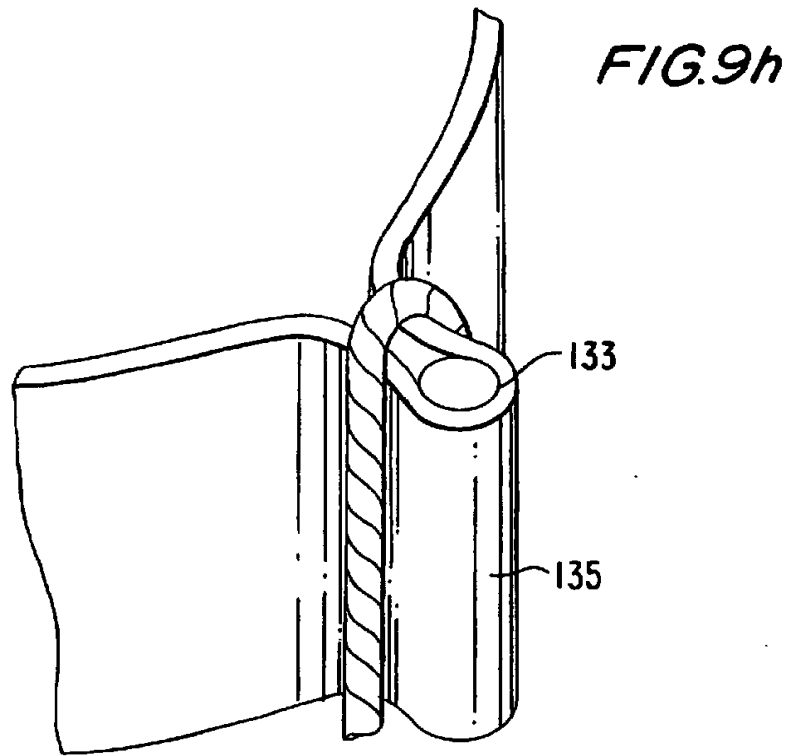
**FIG. 9e**



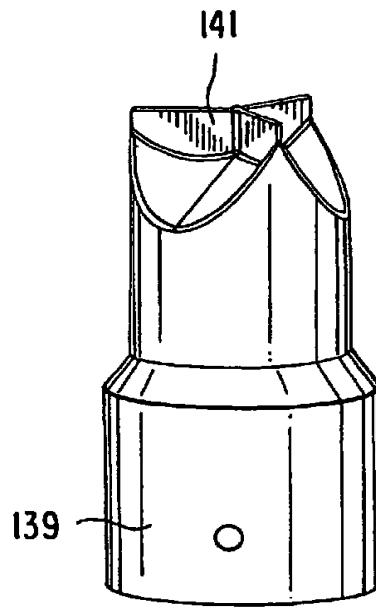
**FIG. 9f**



**FIG. 9g**

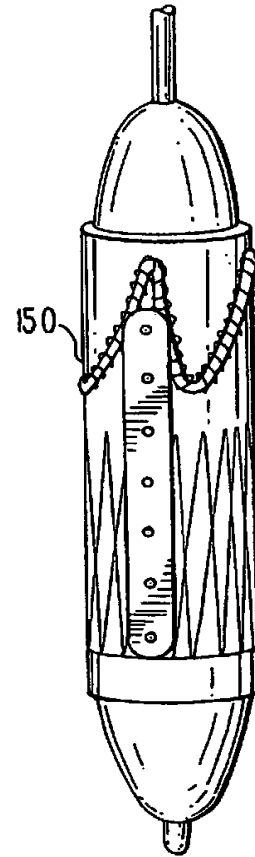
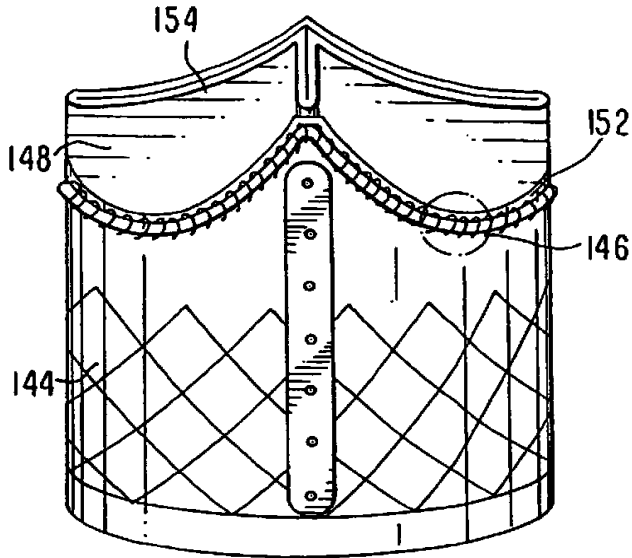




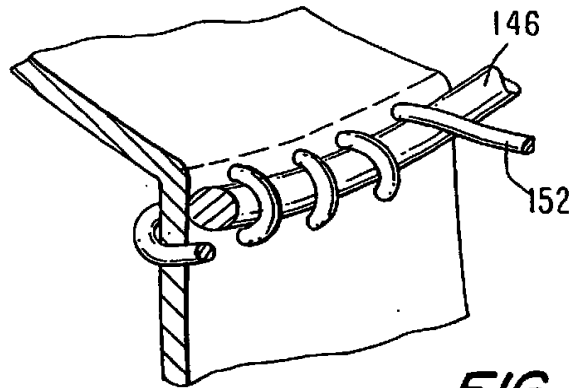


*FIG. 10*

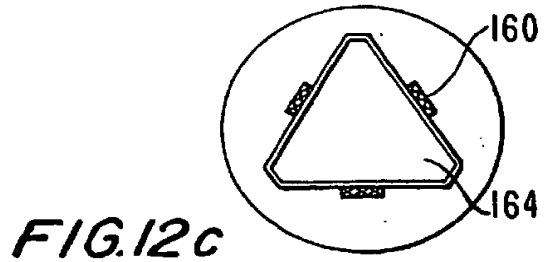
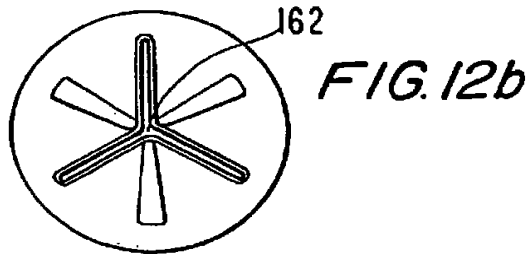
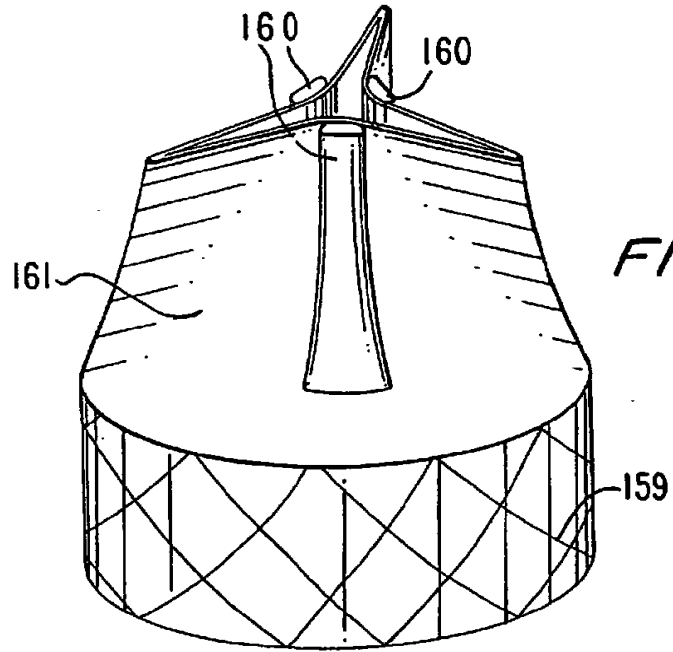
*FIG. 11a*



*FIG. 11b*



*FIG. 11c*



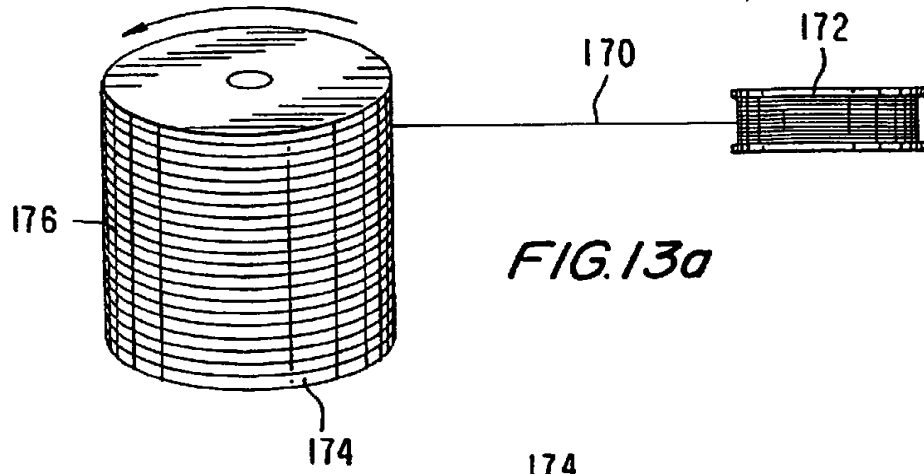


FIG. 13a

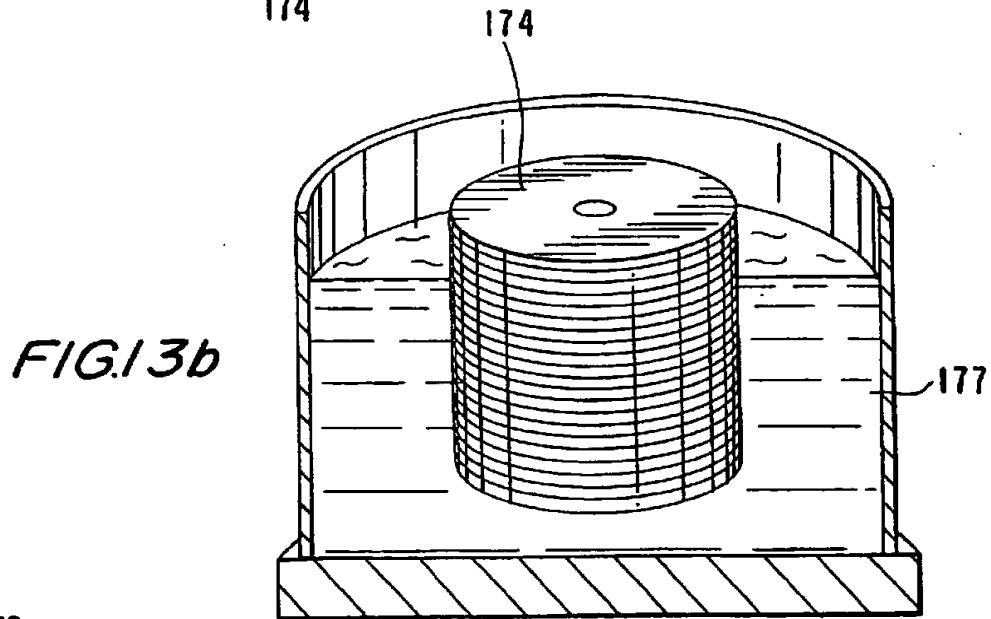


FIG. 13b

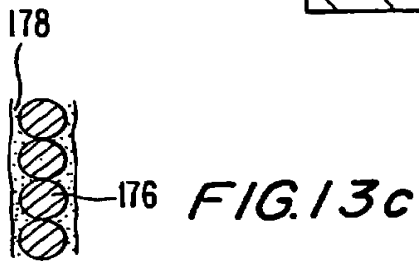
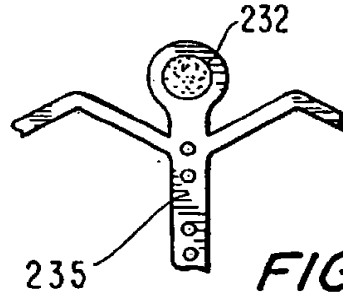
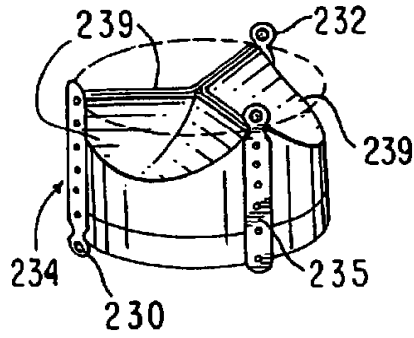
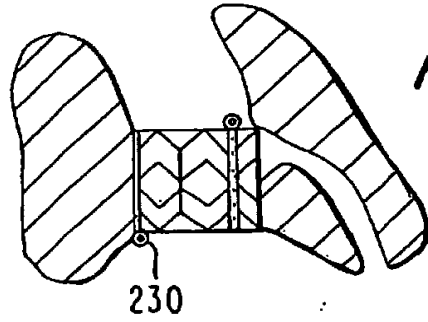


FIG. 13c

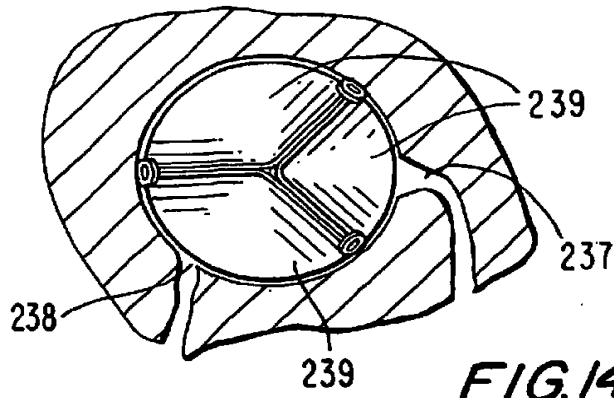
**FIG.14**



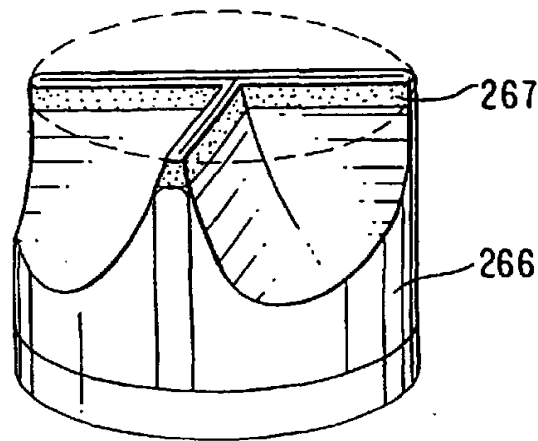
**FIG.14a**



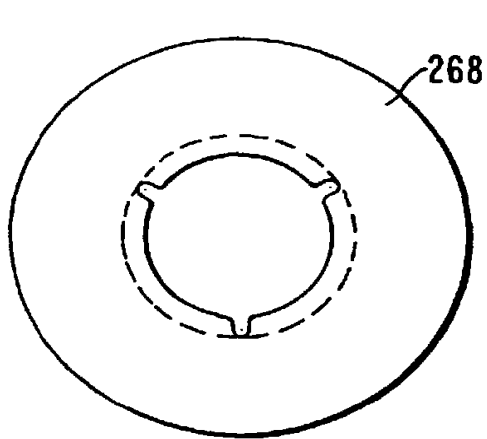
**FIG.14b**



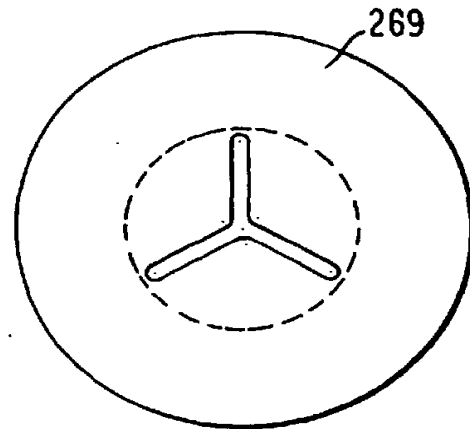
**FIG.14c**



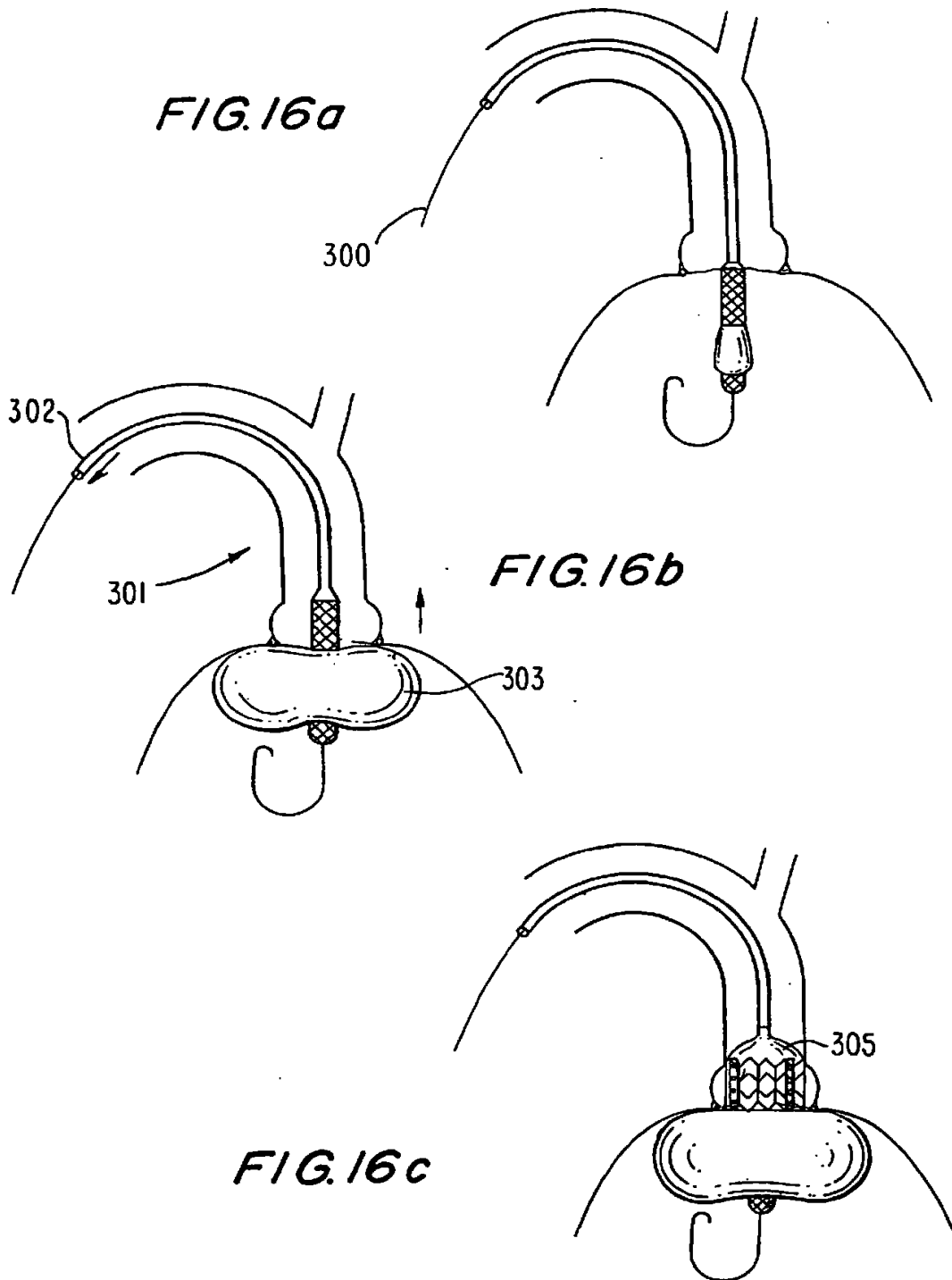
*FIG. 15a*

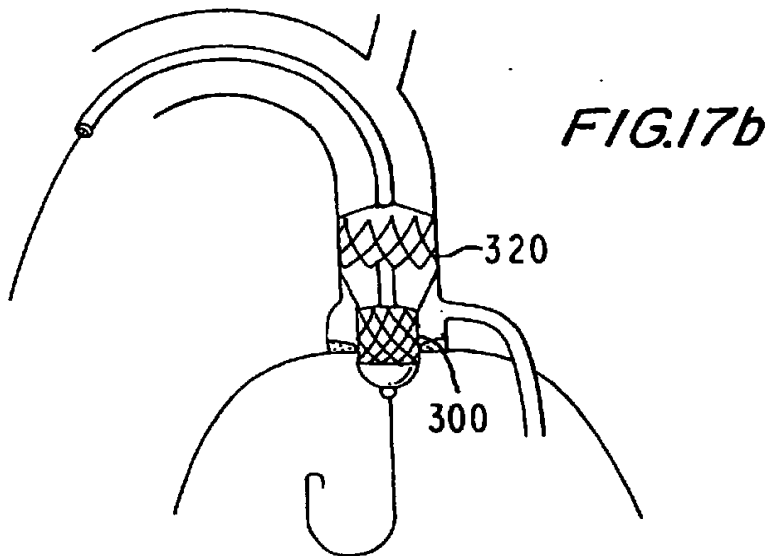
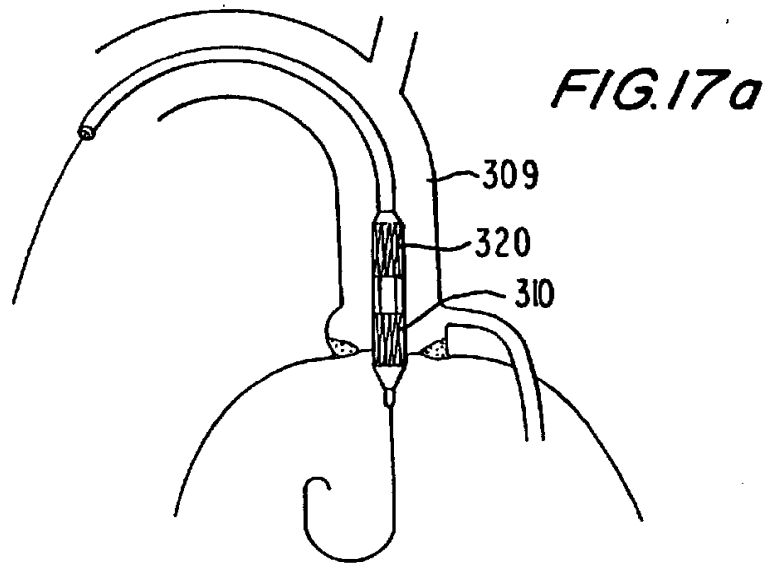


*FIG. 15b*

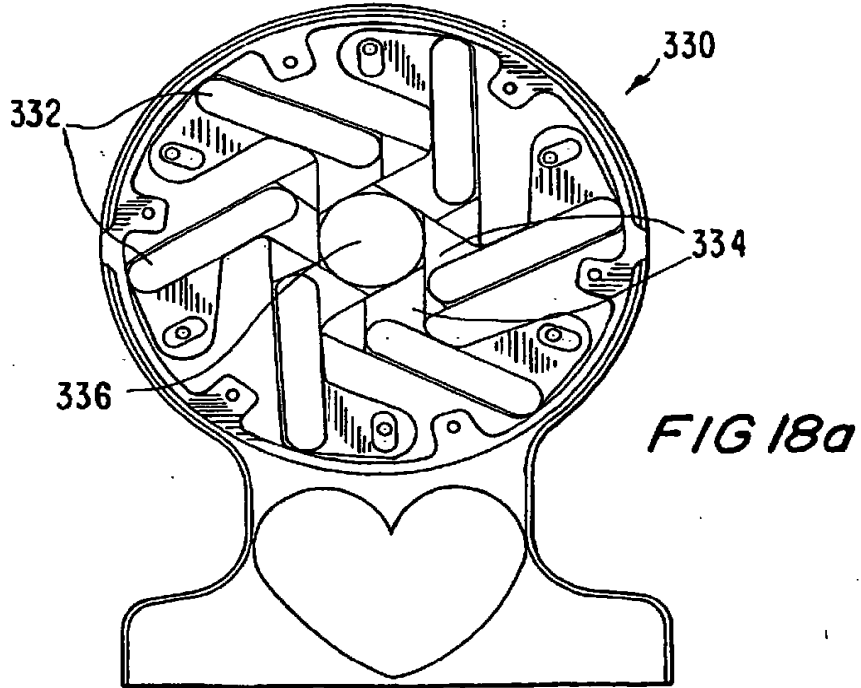
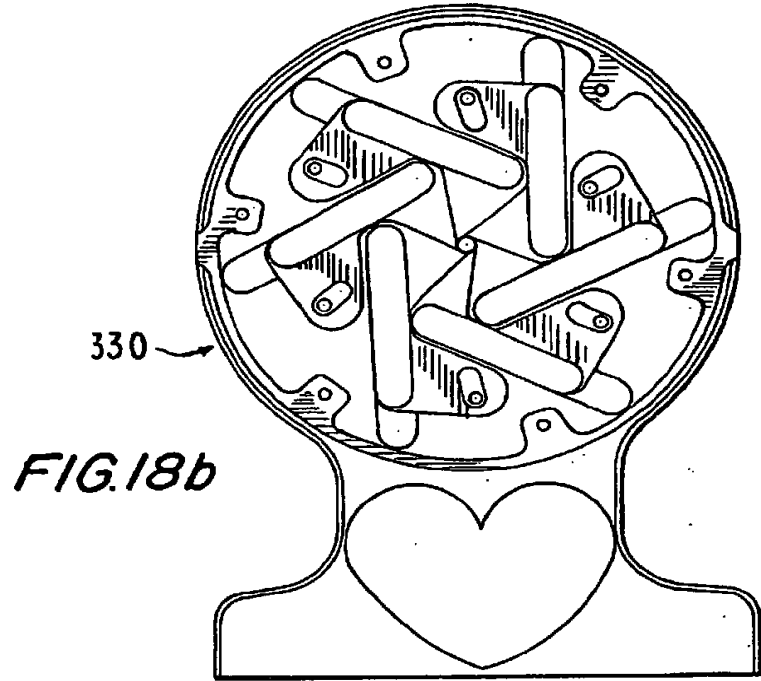


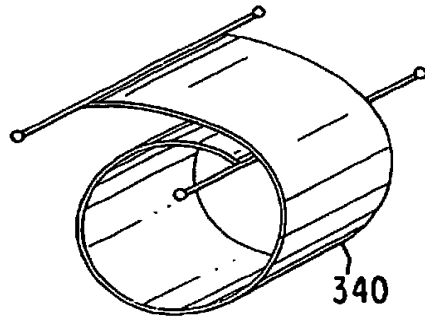
*FIG. 15c*



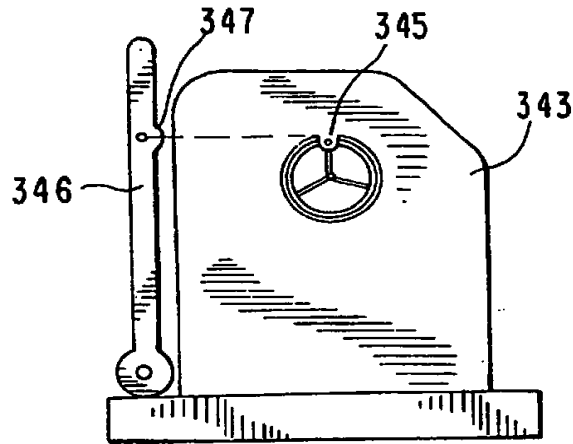




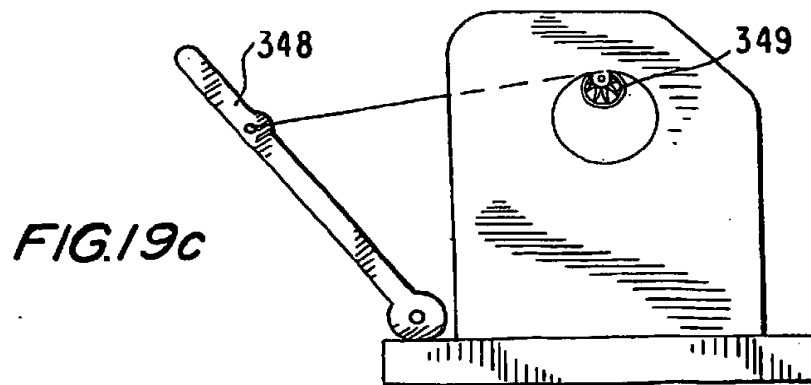




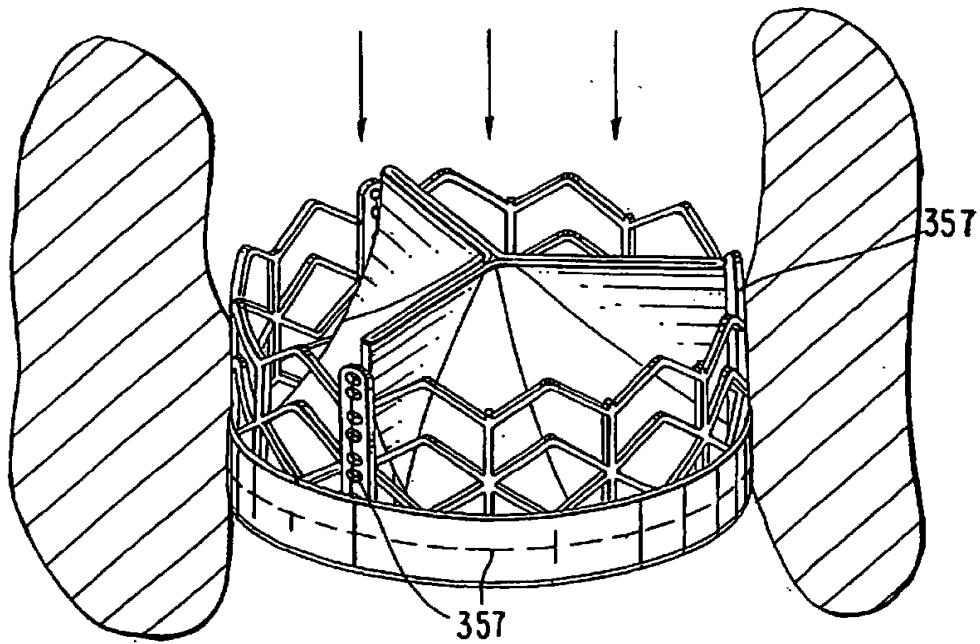
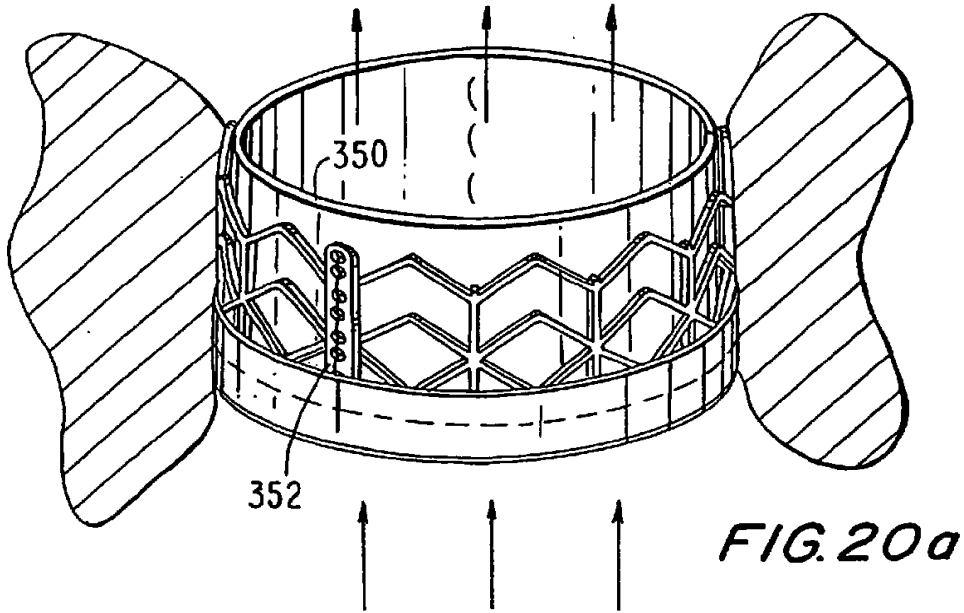
*FIG. 19a*



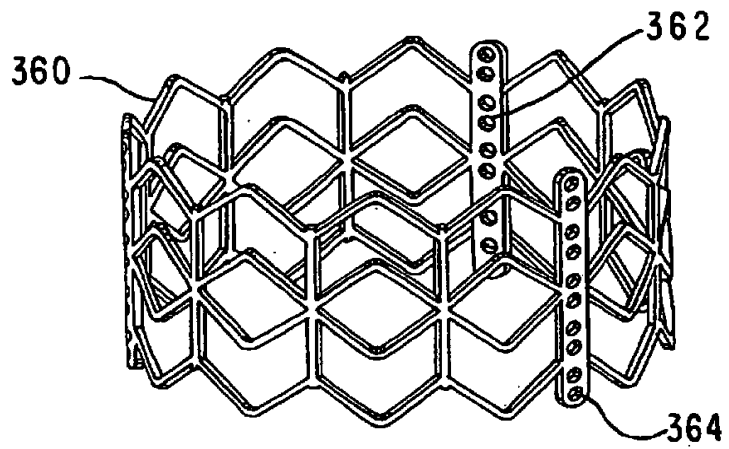
*FIG. 19b*



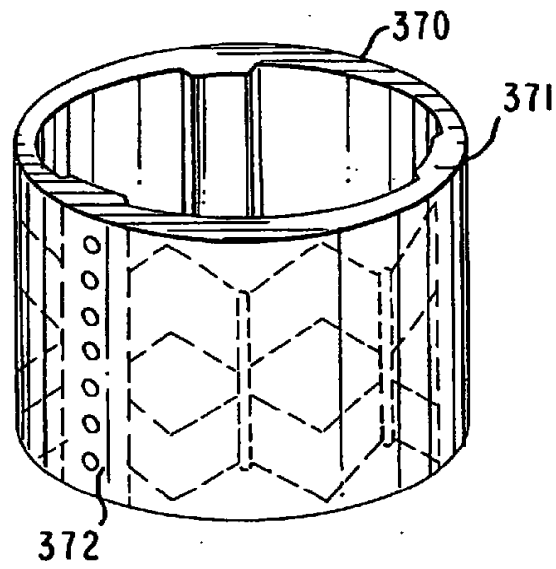
*FIG. 19c*



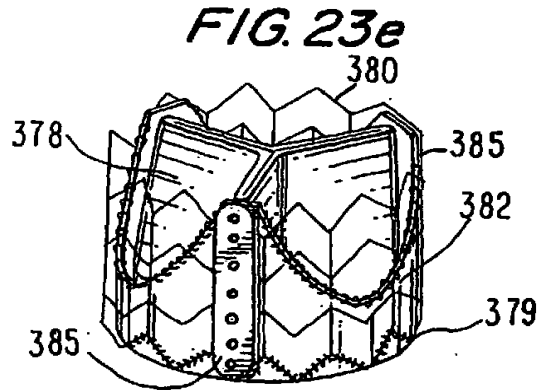
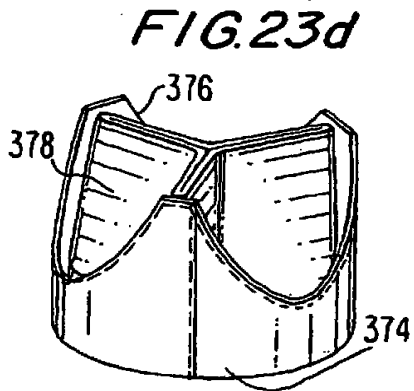
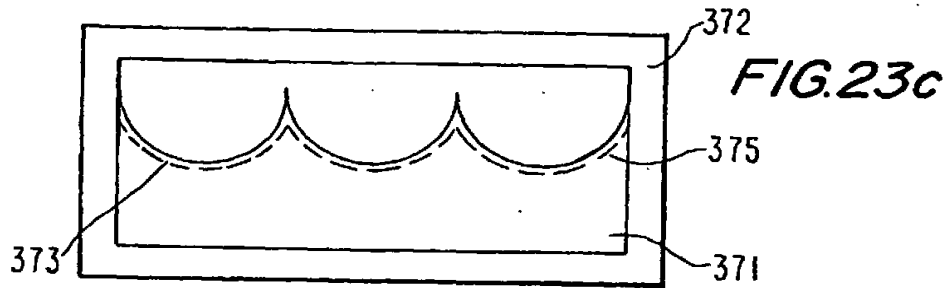
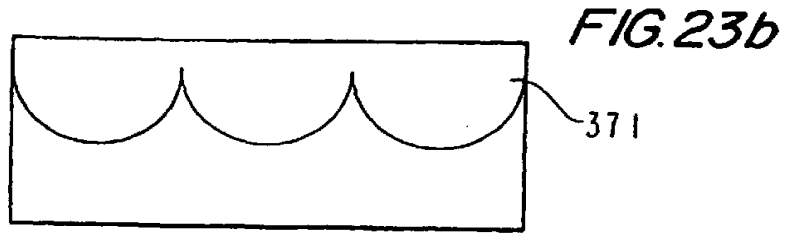
*FIG. 20b*



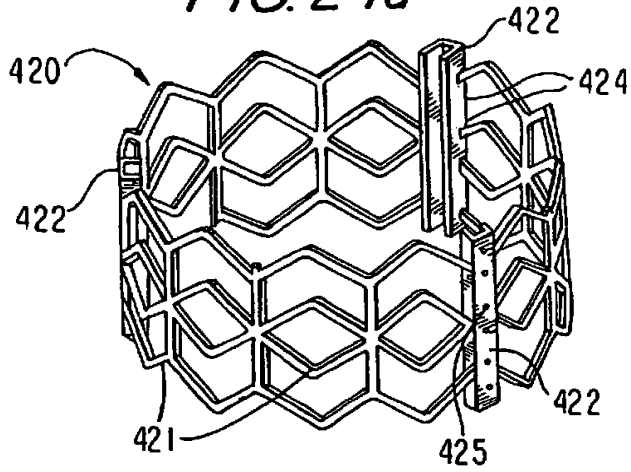
*FIG. 21*



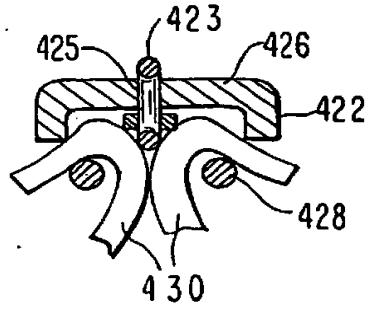
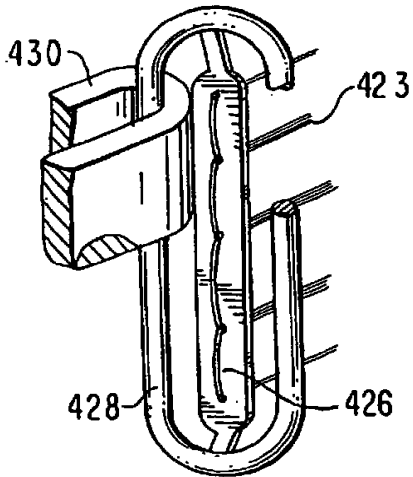
**FIG. 22**



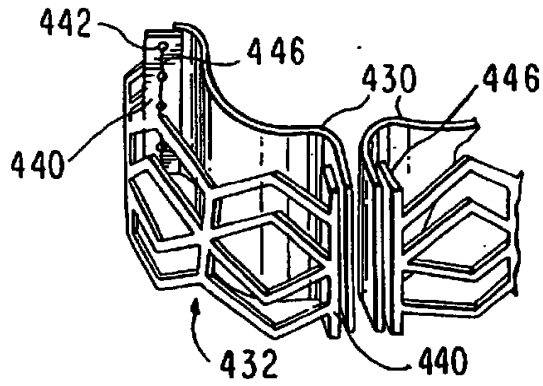
**FIG. 24a**



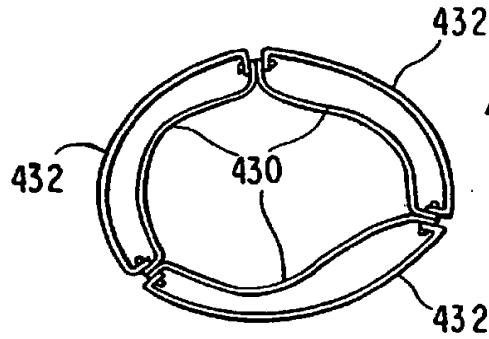
**FIG. 24c**



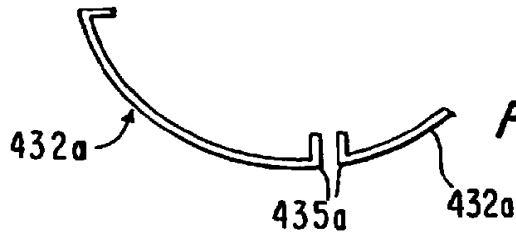
**FIG. 24b**



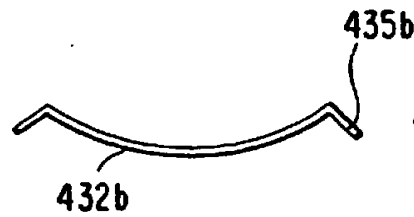
*FIG. 25a*



*FIG. 25b*

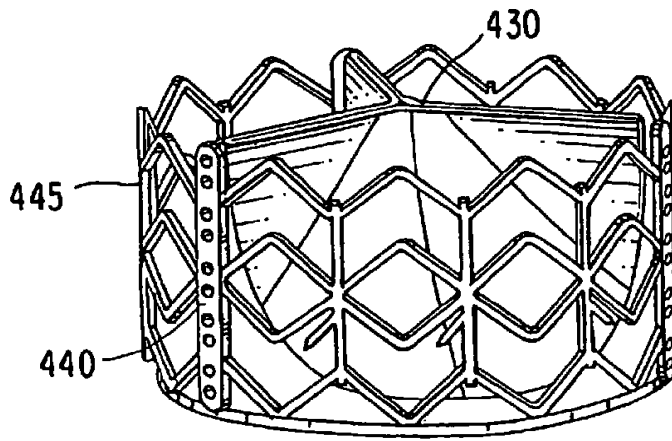


*FIG. 25c*

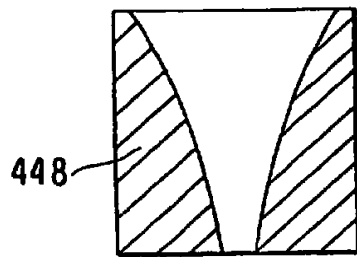


*FIG. 25d*

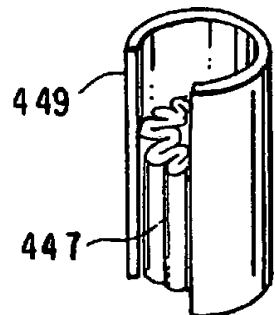




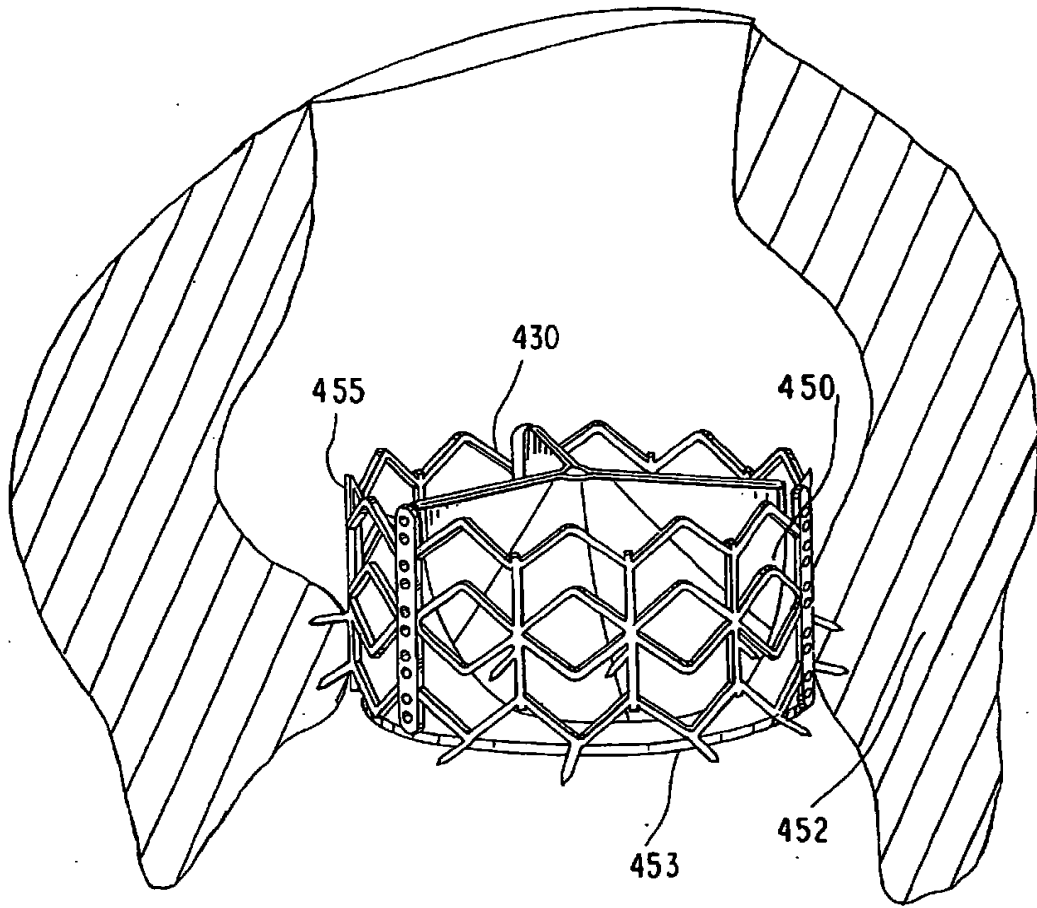
*FIG. 26a*



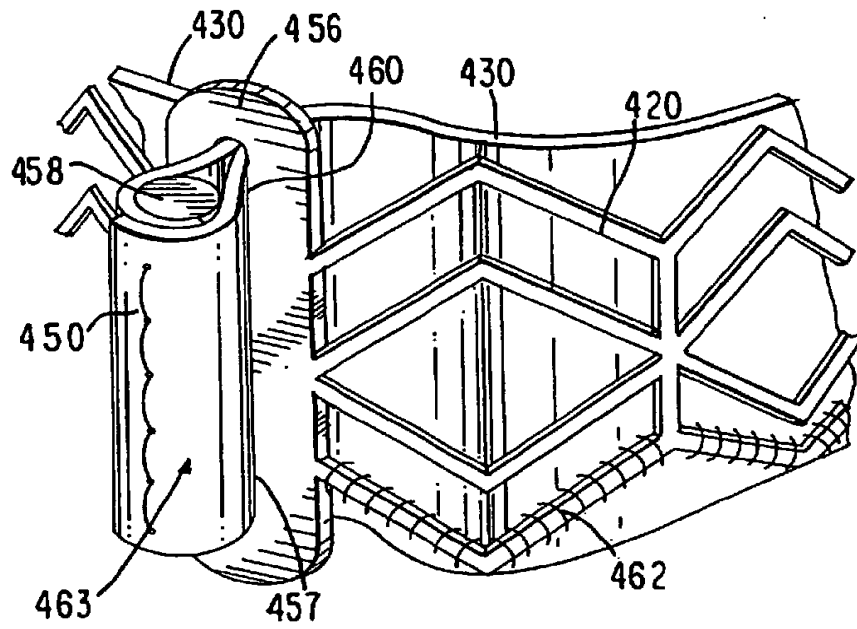
*FIG. 26b*



*FIG. 26c*

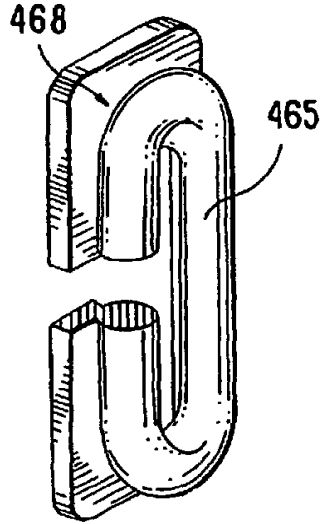


**FIG. 27**

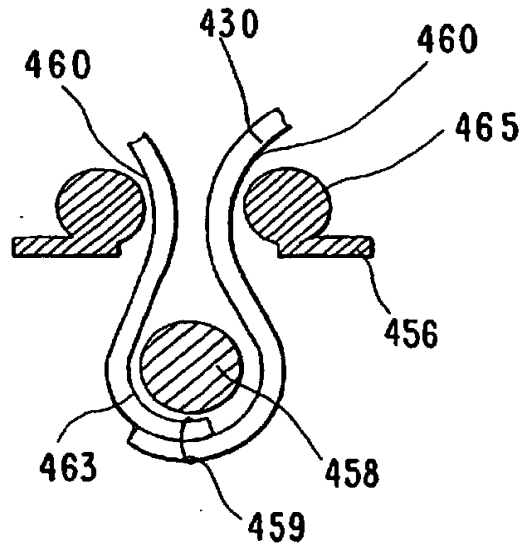


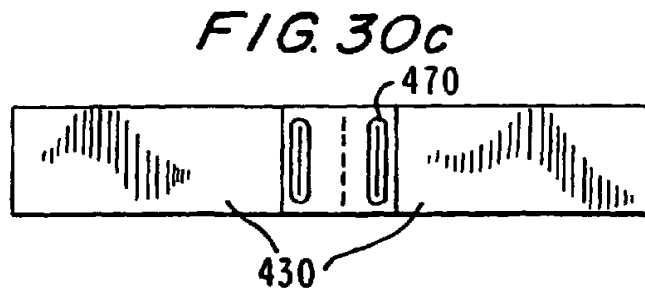
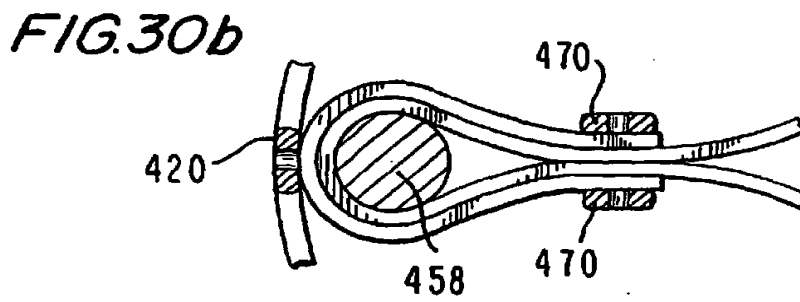
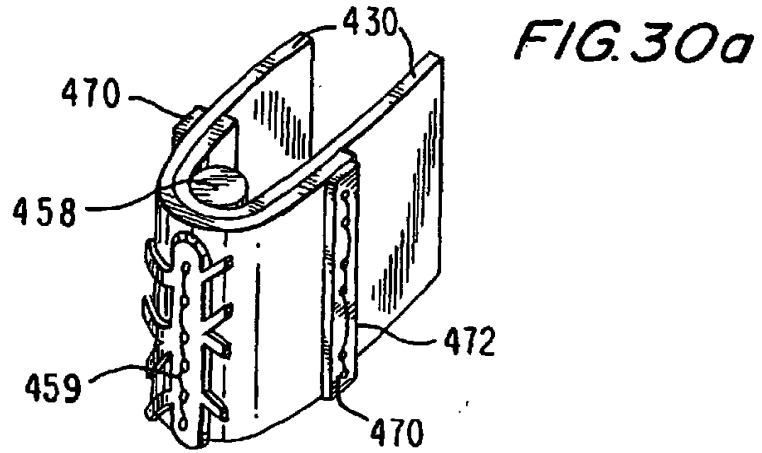
**FIG. 28**

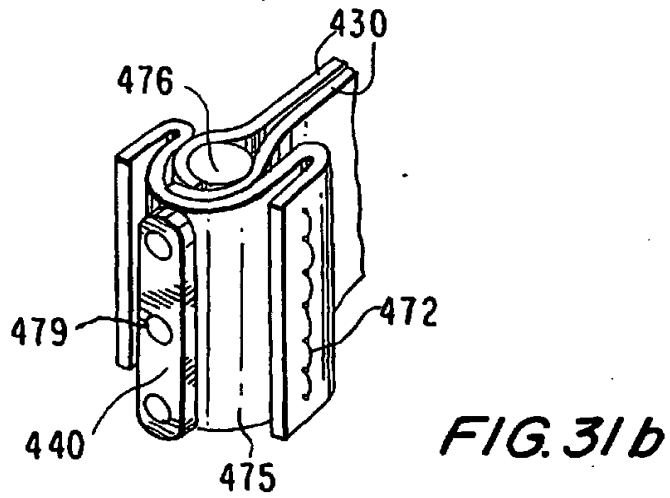
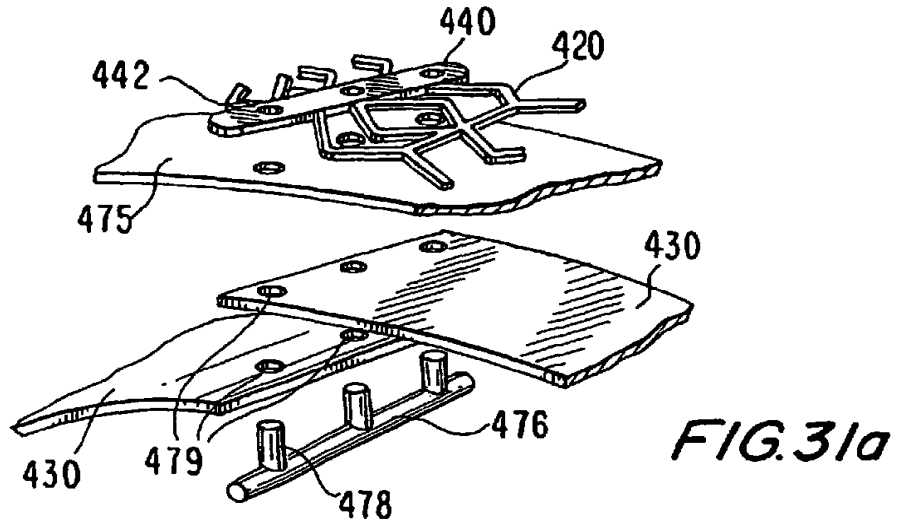
*FIG. 29a*

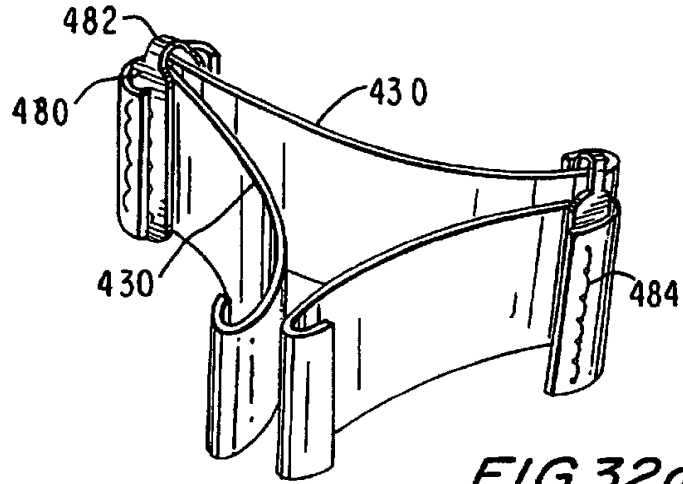


*FIG. 29b*

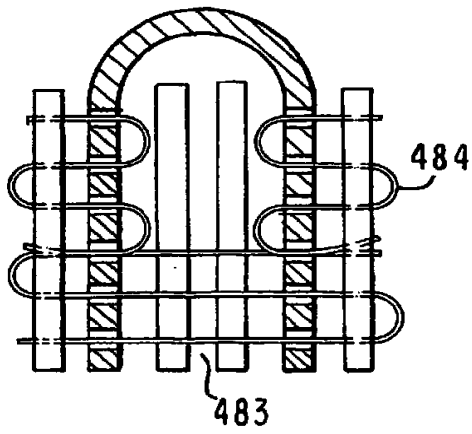




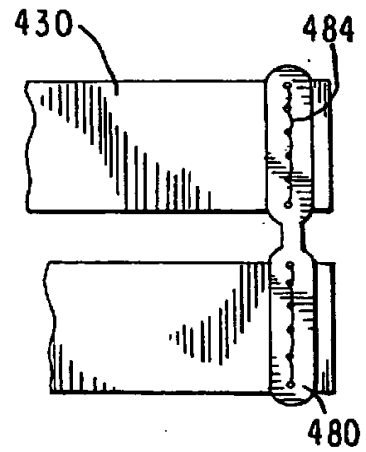




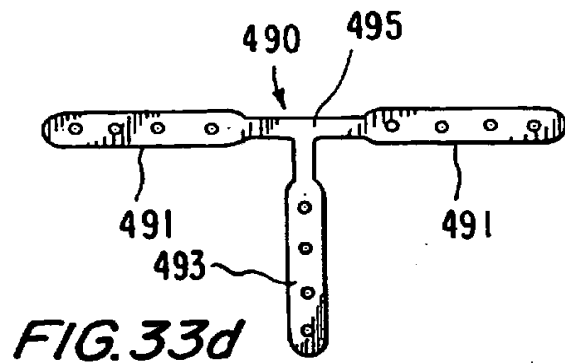
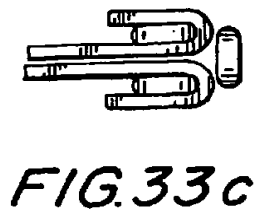
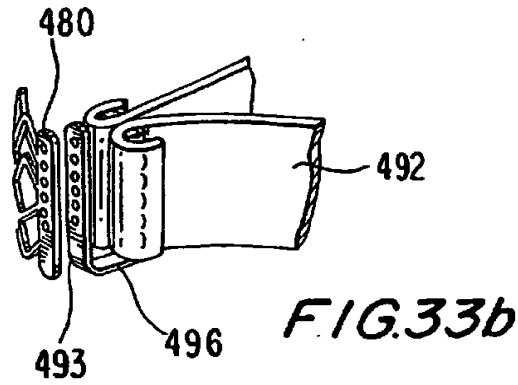
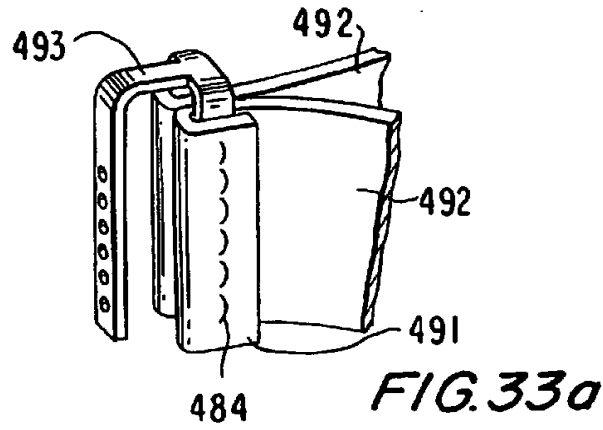
*FIG. 32a*



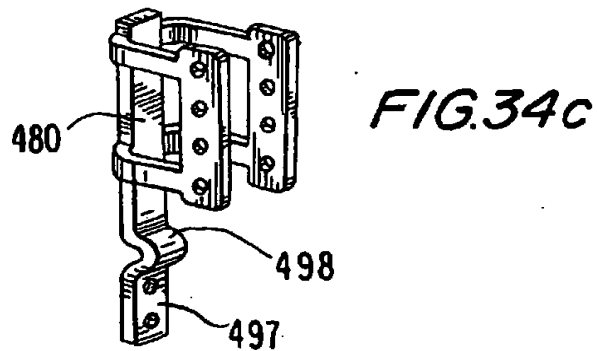
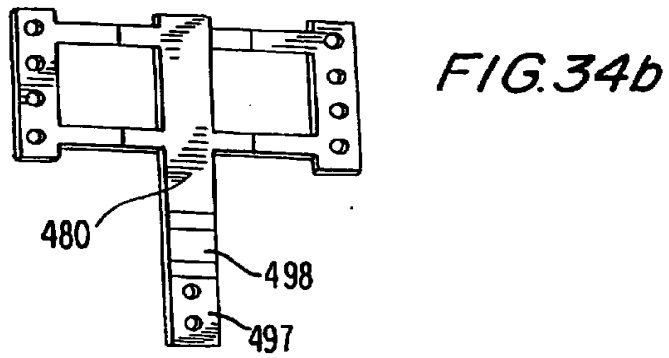
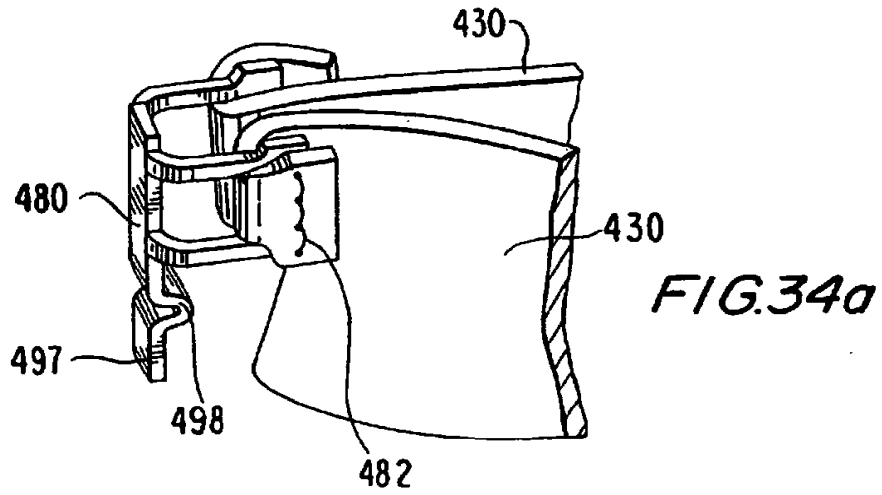
*FIG. 32c*



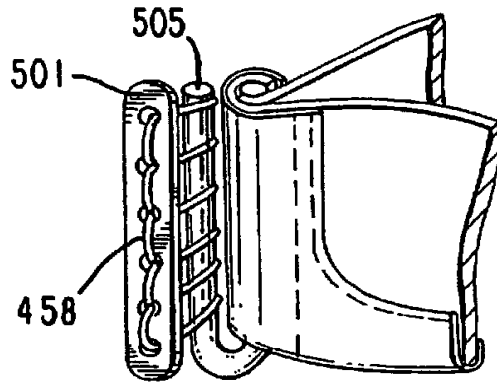
*FIG. 32b*



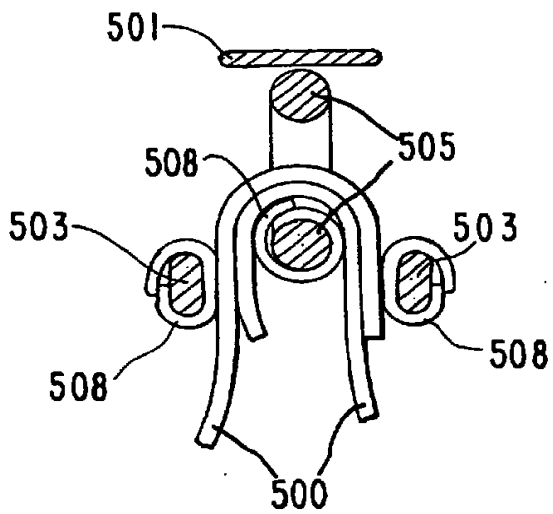




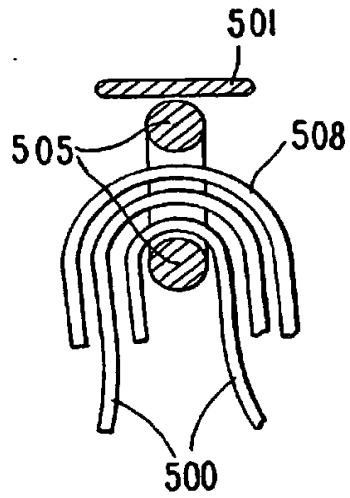
*FIG. 35a*



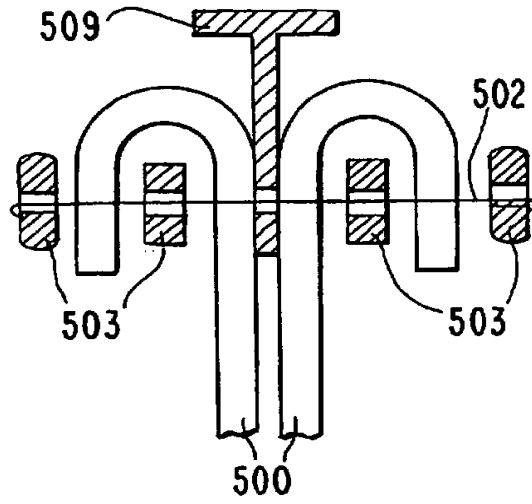
*FIG. 35b*



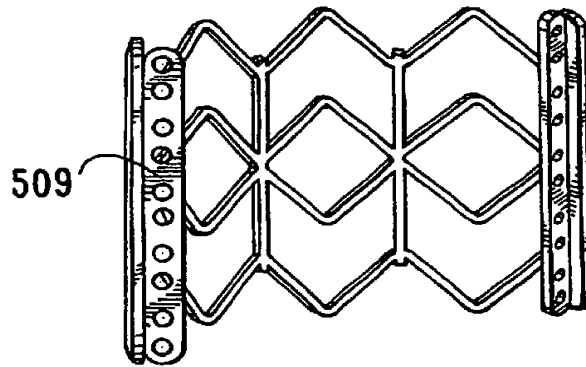
*FIG. 35c*

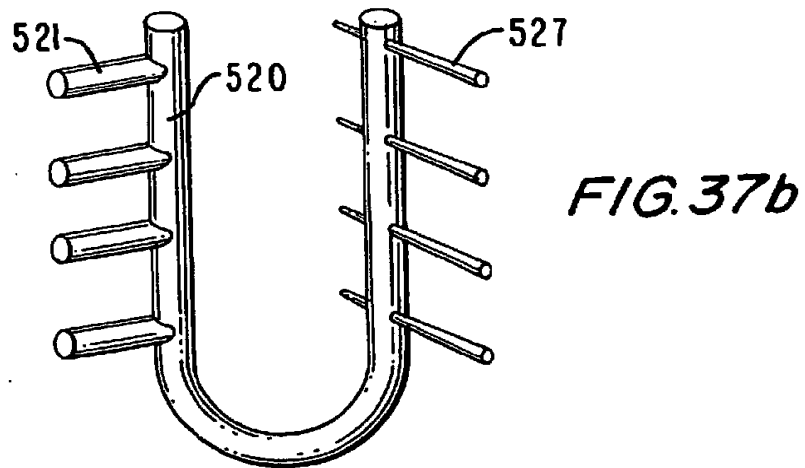
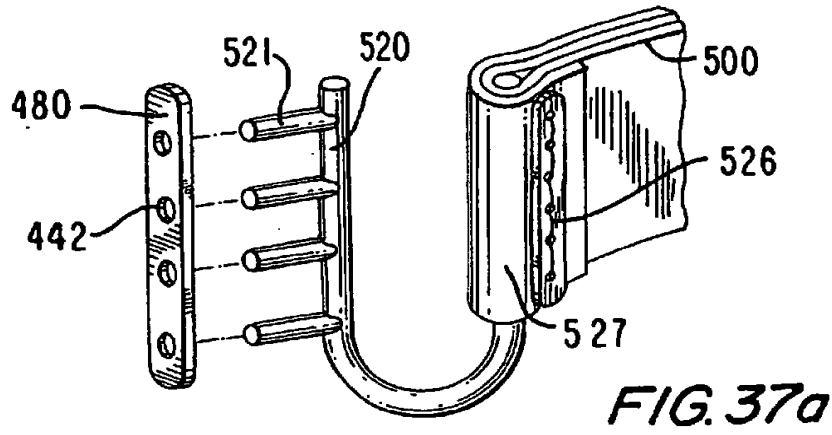


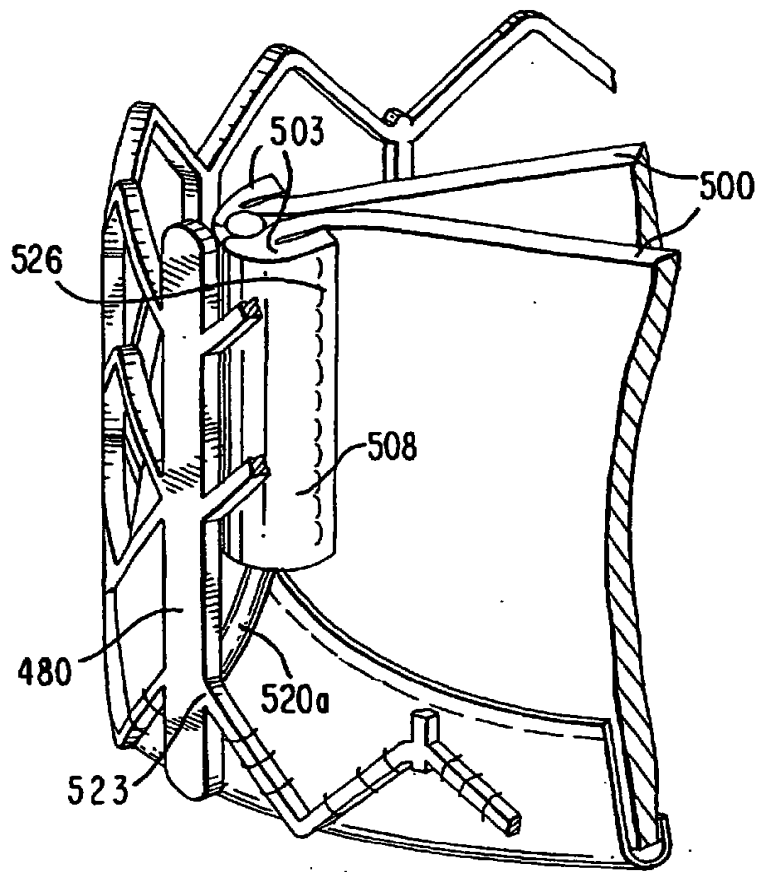
*FIG. 36a*



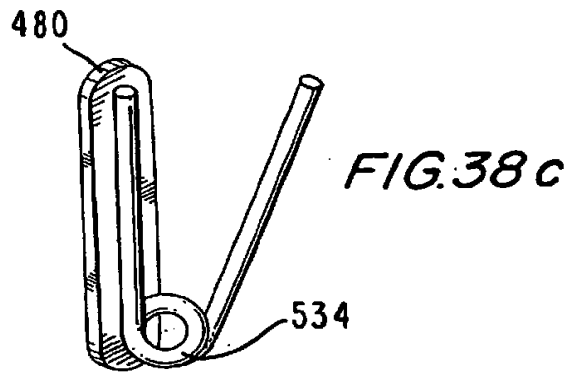
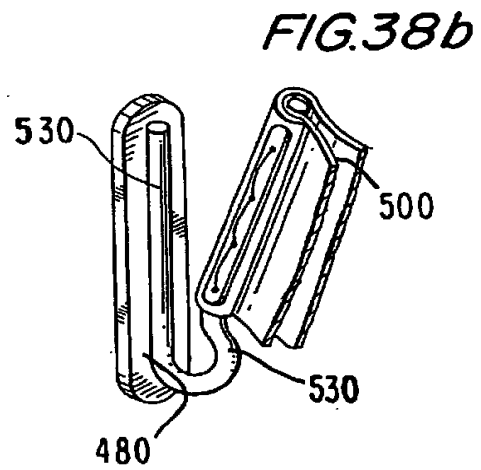
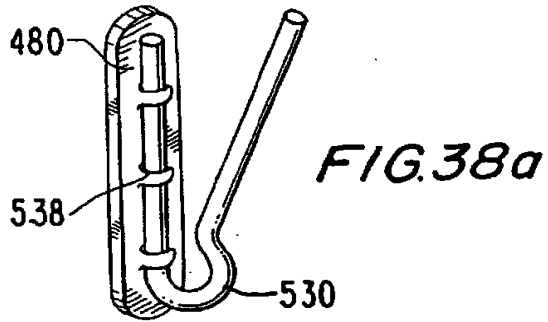
*FIG. 36b*



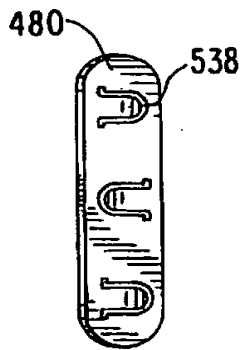
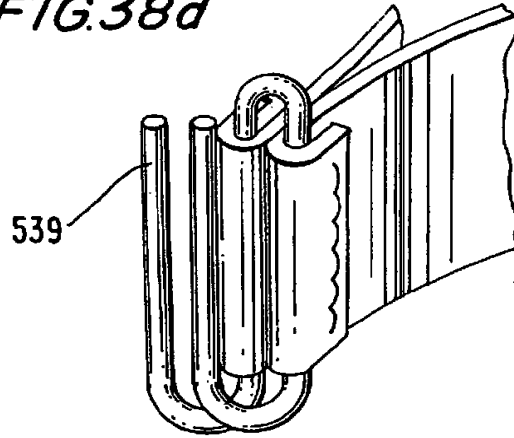




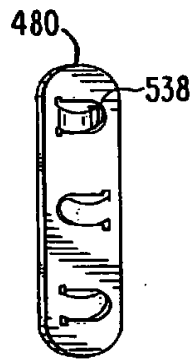
*FIG. 37c*



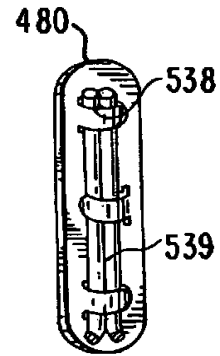
*FIG.38d*



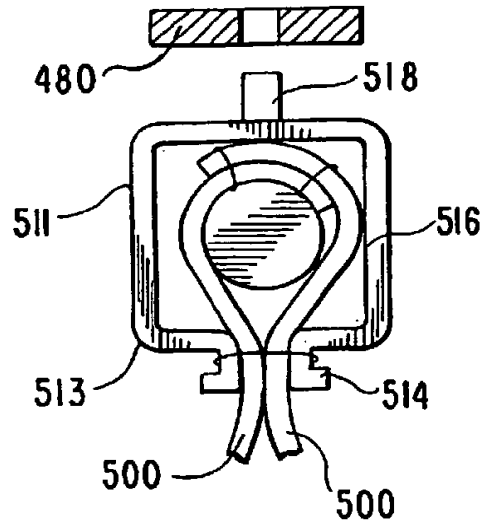
*FIG.38e*



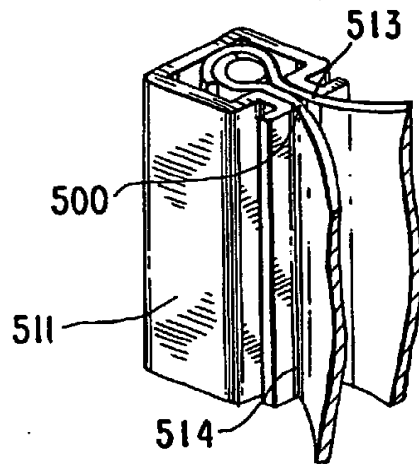
*FIG.38f*



*FIG.38g*

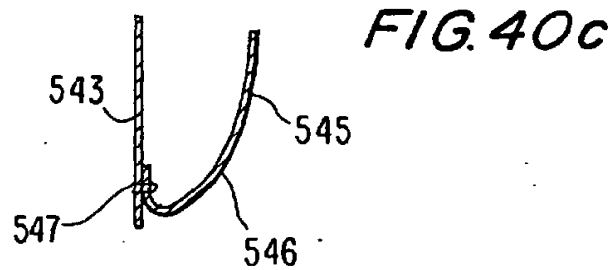
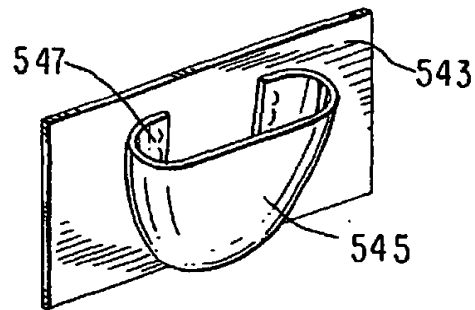
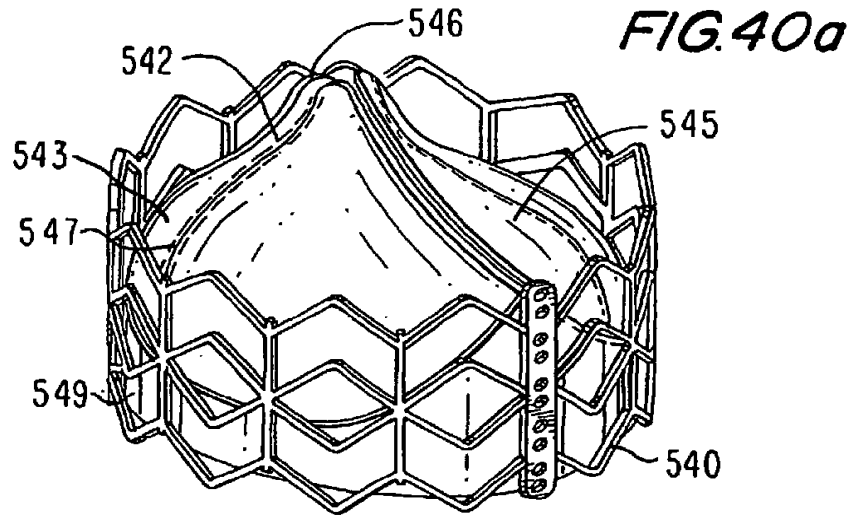


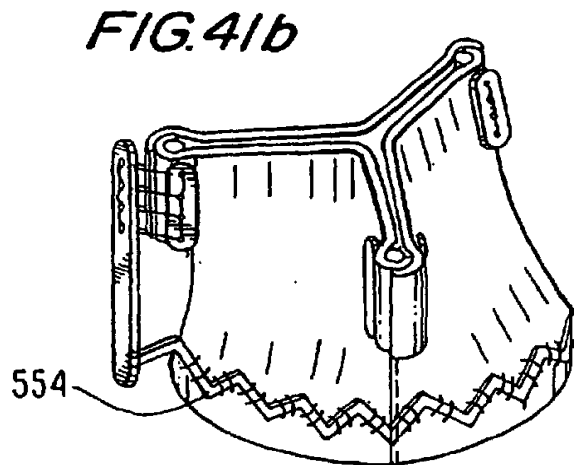
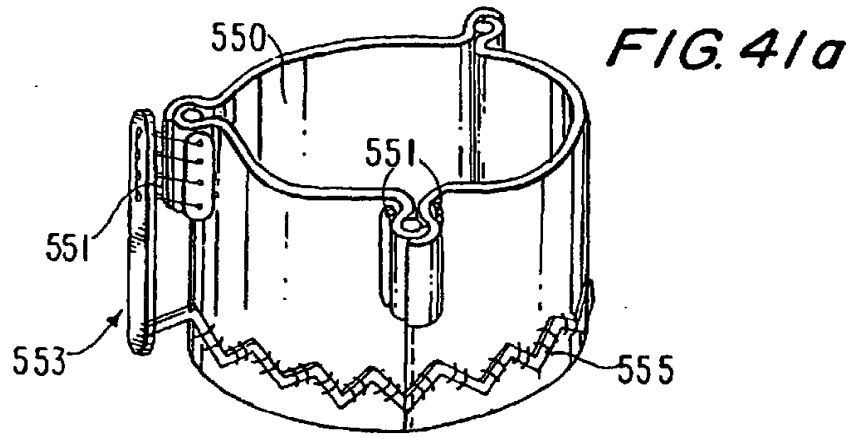
*FIG. 39a*



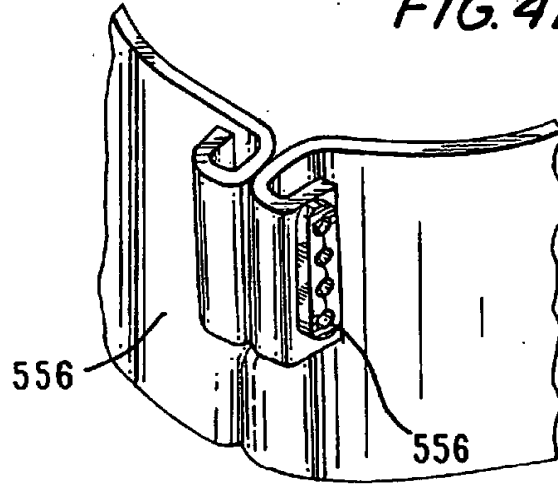
*FIG. 39b*



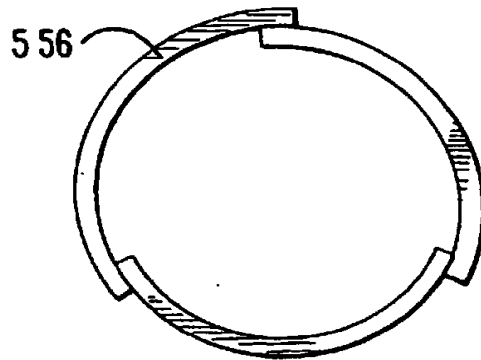


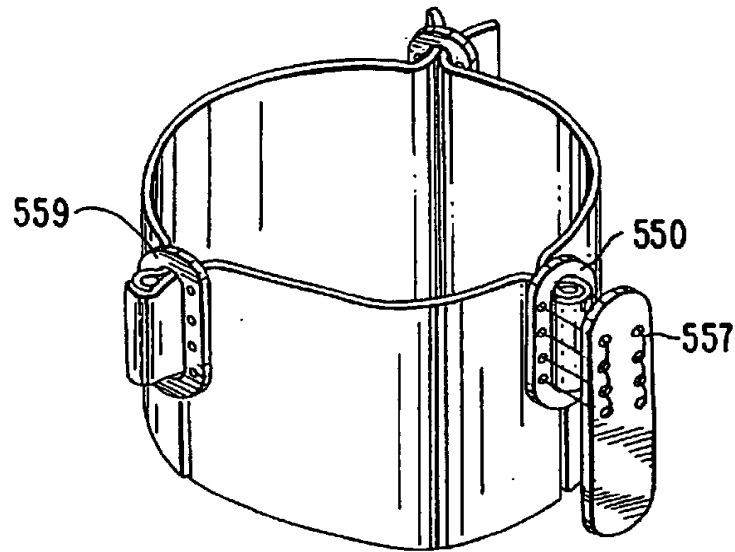


*FIG. 41c*

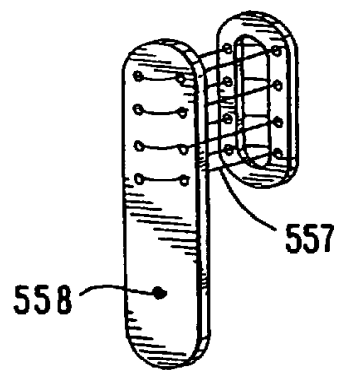


*FIG. 41d*

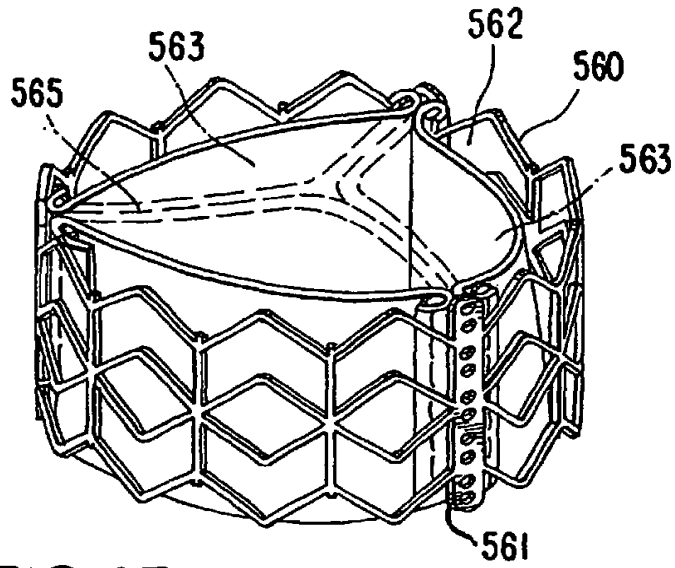




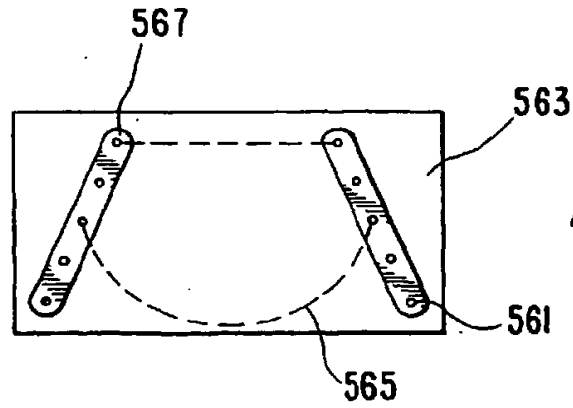
*FIG. 42a*



*FIG. 42b*

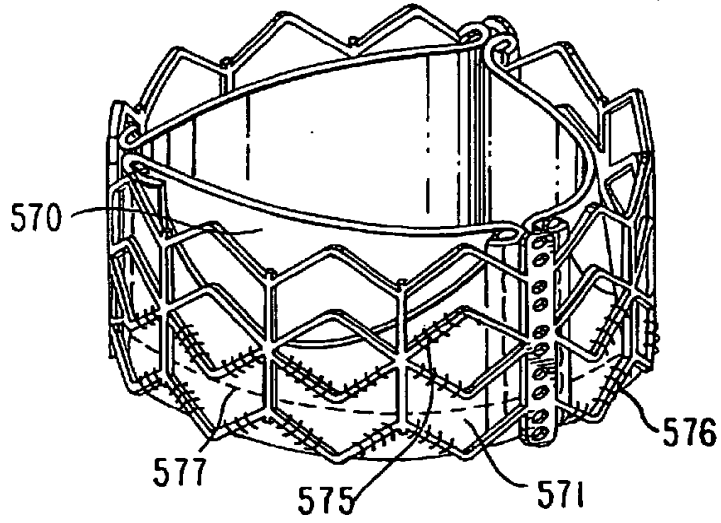


**FIG. 43a**

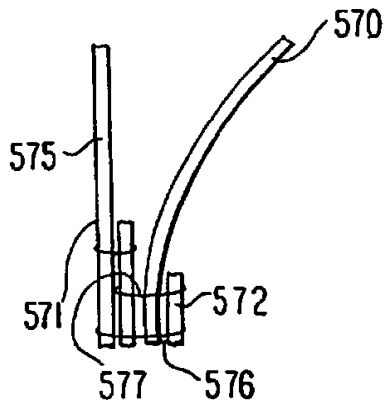


**FIG. 43b**

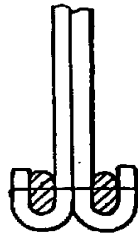
*FIG. 44a*

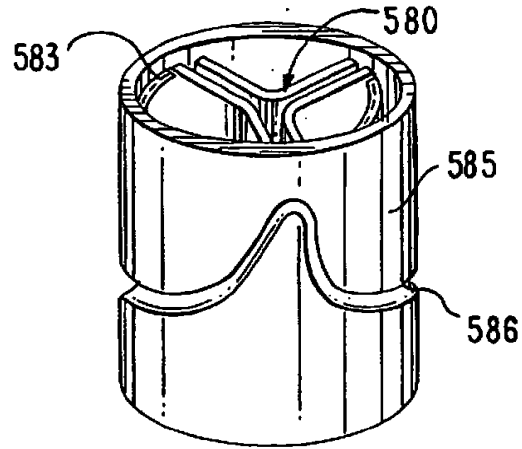


*FIG. 44b*

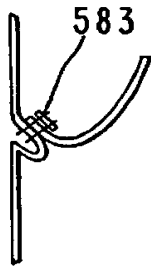


*FIG. 44c*

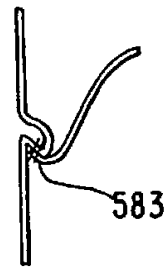




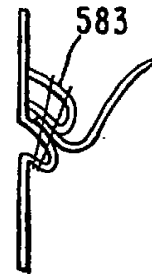
*FIG. 45a*



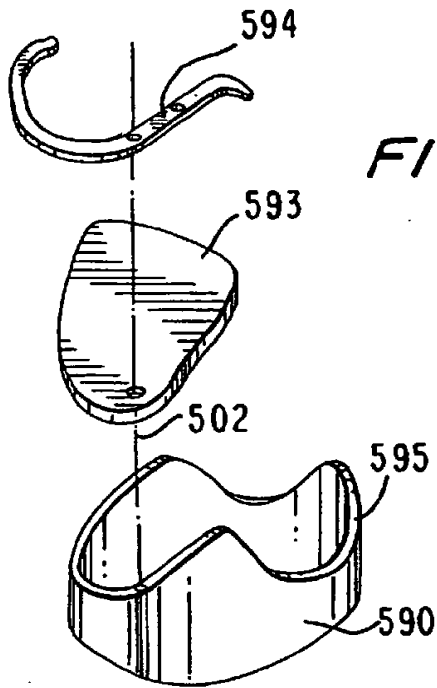
*FIG. 45b*



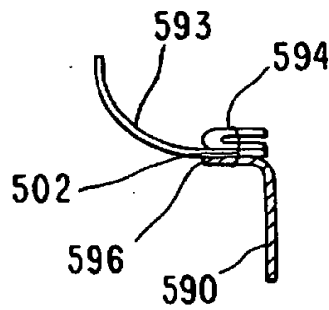
*FIG. 45d*



*FIG. 45c*



*FIG. 46a*



*FIG. 46b*



FIG. 47a

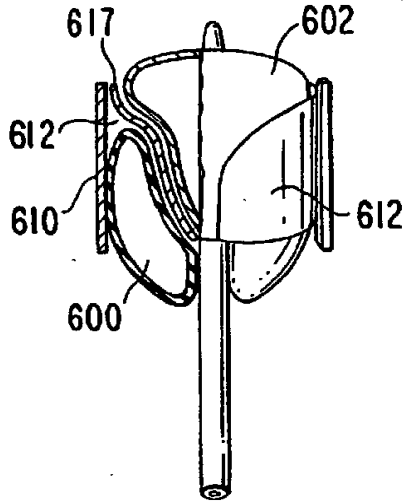


FIG. 47b

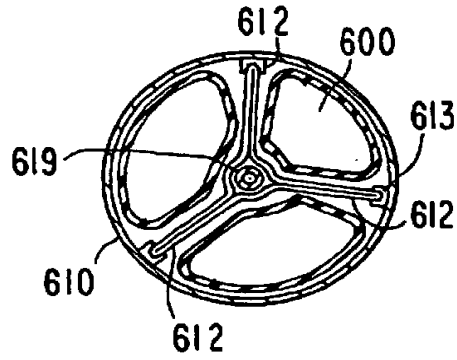
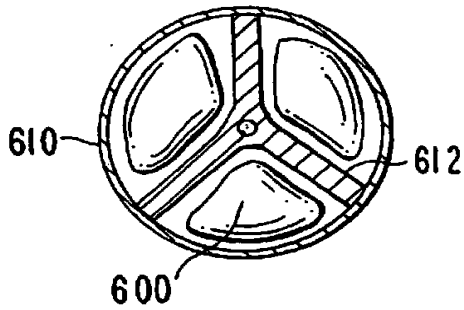
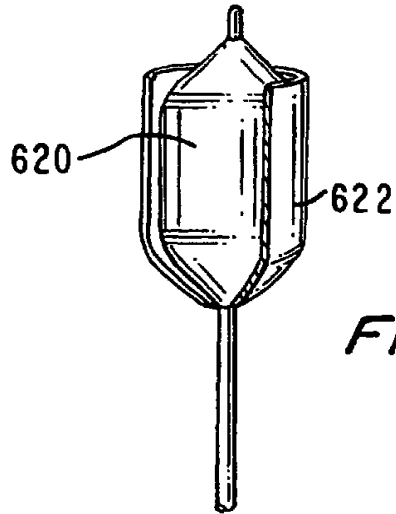
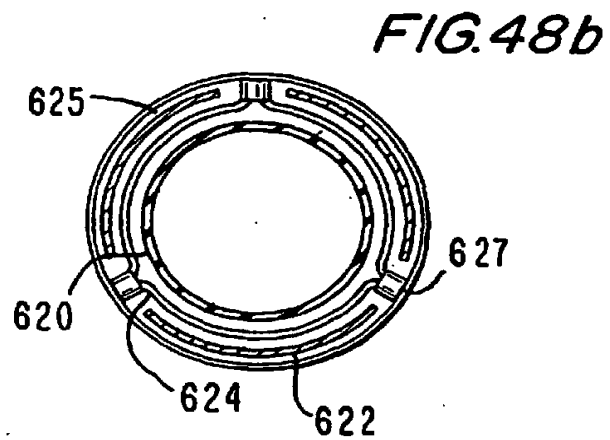


FIG. 47c





*FIG. 48a*



*FIG. 48b*

**REFERENCES CITED IN THE DESCRIPTION**

*This list of references cited by the applicant is for the reader's convenience only. It does not form part of the European patent document. Even though great care has been taken in compiling the references, errors or omissions cannot be excluded and the EPO disclaims all liability in this regard.*

**Patent documents cited in the description**

- US 5411552 A, Andersen **[0002]**
- US 6168614 B, Andersen **[0002]**
- US 5840081 A, Andersen **[0002]**
- EP 9707337 W, Letac, Cribier **[0003]**
- WO 9829057 A **[0003]**
- FR 2788217 A **[0004]**



(11) **EP 1 603 493 B1**

(12) **EUROPEAN PATENT SPECIFICATION**

(45) Date of publication and mention of the grant of the patent:  
**28.12.2011 Bulletin 2011/52**

(51) Int Cl.:  
**A61F 2/24 (2006.01)**

(21) Application number: **04757521.2**

(86) International application number:  
**PCT/US2004/008053**

(22) Date of filing: **17.03.2004**

(87) International publication number:  
**WO 2004/082527 (30.09.2004 Gazette 2004/40)**

(54) **MINIMALLY-INVASIVE HEART VALVE WITH CUSP POSITIONERS**

MINIMALINVASIVE HERZKLAPPE MIT SEGELPOSITIONIERER

VALVE CARDIAQUE A POSE TRES PEU EFFRACTIVE AVEC POSITIONNEURS

(84) Designated Contracting States:  
**AT BE BG CH CY CZ DE DK EE ES FI FR GB GR HU IE IT LI LU MC NL PL PT RO SE SI SK TR**

(72) Inventor: **IOBBI, Mario, M.**  
**Irvine, CA 92612 (US)**

(30) Priority: **18.03.2003 US 390951**

(74) Representative: **Eke, Philippa Dianne**  
**Saunders & Dolleymore LLP**  
**9 Rickmansworth Road**  
**Watford**  
**Hertfordshire WD18 0JU (GB)**

(43) Date of publication of application:  
**14.12.2005 Bulletin 2005/50**

(60) Divisional application:  
**10164361.7 / 2 241 287**

(56) References cited:  
**SU-A- 1 116 573 US-A- 5 716 417**  
**US-B1- 6 231 602 US-B1- 6 461 382**

(73) Proprietor: **Edwards Lifesciences Corporation**  
**Irvine, CA 92614 (US)**

**EP 1 603 493 B1**

Note: Within nine months of the publication of the mention of the grant of the European patent in the European Patent Bulletin, any person may give notice to the European Patent Office of opposition to that patent, in accordance with the Implementing Regulations. Notice of opposition shall not be deemed to have been filed until the opposition fee has been paid. (Art. 99(1) European Patent Convention).

## Description

### Field of the Invention

**[0001]** The present invention relates generally to medical implants, and more particularly to minimally-invasive or collapsible/expandable heart valves and methods of delivering and implanting such valves.

### Background of the Invention

**[0002]** Prosthetic heart valves are used to replace damaged or diseased heart valves. In vertebrate animals, the heart is a hollow muscular organ having four pumping chambers: the left and right atria and the left and right ventricles, each provided with its own one-way valve. The natural heart valves are identified as the aortic, mitral (or bicuspid), tricuspid and pulmonary valves. Prosthetic heart valves can be used to replace any of these naturally occurring valves, although repair or replacement of the aortic or mitral valves is most common because they reside in the left side of the heart where pressures are the greatest.

**[0003]** Where replacement of a heart valve is indicated, the dysfunctional valve is typically cut out and replaced with either a mechanical valve, or a tissue or bioprosthetic-type valve. Bioprosthetic-type valves are often preferred over mechanical valves because they typically do not require long-term treatment with anticoagulants. The most common bioprosthetic-type valves are constructed with whole porcine (pig) valves, or with separate leaflets cut from bovine (cow) pericardium.

**[0004]** Although so-called stentless valves, comprising a section of xenograft (e.g., porcine) aorta and valve, are available, the most widely used valves include some form of artificial leaflet support. One such support is an elastic "support frame," sometimes called a "wireform" or "stent," which has a plurality (typically three) of large radius U-shaped cusps supporting the cusp region of the leaflets of the bioprosthetic tissue (i.e., either a whole valve or three separate leaflets). The free ends of each two adjacent cusps converge somewhat asymptotically to form upstanding commissures that terminate in U-shaped tips, each being curved in the opposite direction as the cusps, and having a relatively smaller radius. The support frame typically describes a conical tube with the commissure tips at the small diameter end. This provides an undulating reference shape to which a fixed edge of each leaflet attaches (via components such as fabric and sutures) much like the natural fibrous skeleton in the aortic annulus. Therefore, the alternating cusps and commissures mimic the natural contour of leaflet attachment. Importantly, the wireform provides continuous support for each leaflet along the cusp region so as to better simulate the natural support structure.

**[0005]** The support frame is typically a non-ferromagnetic metal such as ELGILOY (a Co-Cr alloy) that possesses substantial elasticity. A common method of form-

ing metallic support frames is to bend a wire into a flat (two-dimensional) undulating pattern of the alternating cusps and commissures, and then roll the flat pattern into a tube using a cylindrical roller. The free ends of the resulting three-dimensional shape, typically in the asymptotic region of the cusps, are then fastened together using a tubular splice that is plastically crimped around the ends. See Figs. 3 and 4 of U.S. Patent No. 6,296,662 for a support frame that is crimped together at a cusp midpoint

**[0006]** Some valves include polymeric "support frames" rather than metallic, for various reasons. For example, U.S. Patent No. 5,895,420 discloses a plastic support frame that degrades in the body over time. Despite some favorable attributes of polymeric support frames, for example the ability to mold the complex support frame shape, conventional metallic support frames are generally preferred for their elastic properties, and have a proven track record in highly successfully heart valves. For example, the CARPENTIER-EDWARDS Porcine Heart Valve and PERIMOUNT Pericardial Heart Valve available from Edwards Lifesciences LLC both have ELGILOY support frames and have together enjoyed the leading worldwide market position since 1976.

**[0007]** A conventional heart valve replacement surgery involves accessing the heart in the patient's thoracic cavity through a longitudinal incision in the chest. For example, a median sternotomy requires cutting through the sternum and forcing the two opposing halves of the rib cage to be spread apart, allowing access to the thoracic cavity and heart within. The patient is then placed on cardiopulmonary bypass which involves stopping the heart to permit access to the internal chambers. Such open heart surgery is particularly invasive and involves a lengthy and difficult recovery period.

**[0008]** Some attempts have been made to enable less traumatic delivery and implantation of prosthetic heart valves. For instance, U.S. Patent No. 4,056,854 to Boretos discloses a radially collapsible heart valve secured to a circular spring stent that can be compressed for delivery and expanded for securing in a valve position. Also, U.S. Patent No. 4,994,077 to Dobbin describes a disk-shaped heart valve that is connected to a radially collapsible stent for minimally invasive implantation.

**[0009]** Recently, a great amount of research has been done to reduce the trauma and risk associated with conventional open heart valve replacement surgery. In particular, the field of minimally invasive surgery (MIS) has exploded since the early to mid-1990s, with devices now being available to enable valve replacements without opening the chest cavity. MIS heart valve replacement surgery still typically requires bypass, but the excision of the native valve and implantation of the prosthetic valve are accomplished via elongated tubes or cannulas, with the help of endoscopes and other such visualization techniques.

**[0010]** Some examples of more recent MIS heart valves are shown in U.S. Patent No. 5,411,552 to Ander-

son, et al., U.S. Patent No. 5,980,570 to Simpson, U.S. Patent No. 5,984,959 to Robertson, et al., U.S. Patent No. 6,425,916 to Garrison, et al., and PCT Publication No. WO 99/334142 to Vesely.

**[0011]** Although these and other such devices provide various ways for collapsing, delivering, and then expanding a "heart valve" per se, none of them disclose much structural detail of the valve itself. For instance, the publication to Vesely shows a tissue leaflet structure of the prior art in Fig. 1, and an expandable inner frame of the invention having stent posts in Figs. 3A-3C. The leaflets are "mounted to the stent posts 22 in a manner similar to that shown in Fig. 1." Likewise, Anderson describes mounting a porcine valve inside of an expandable stent "by means of a suitable number of sutures to form the cardiac valve prosthesis 9 shown in Fig. 2." Such general disclosures stop short of explaining how to construct a valve in a manner that maximizes long-term efficacy. In particular, the particular means of attaching the leaflets to the MIS stent is critical to ensure the integrity and durability of the valve once implanted. All of the prior art MIS valves are inadequate in this regard. Furthermore, use of conventional support stents or wireforms is difficult in MIS valves because of the need to compress the valve into a relatively small diameter delivery package, which creates material challenges.

**[0012]** Some MIS valves of the prior art are intended to be used without removing the natural valve leaflets. Sometimes the natural leaflets are heavily calcified, and their removal entails some risk of plaque particles being released into the bloodstream. Therefore, some of the MIS valves are designed to expand outward within the annulus and native leaflets, and compress the leaflets against the annulus. The relatively uneven surface of the calcified annulus and leaflets creates sizing problems and may complicate the delivery and placement steps. Prior art MIS valves are essentially tubular stents embellished with a native xenograft valve. The implant methodology is simply the conventional balloon expansion technique or pushing a self-expanding version from the end of a catheter. Minimal control over the placement of the valve is provided or contemplated.

**[0013]** Despite some advances in MIS valve design, there remains a need for an MIS valve that is durable and which has a more flexible delivery and implantation methodology.

**[0014]** A prior art aortic annuloplasty ring is known from US 6,231,602, which comprises a flexibly semi-rigid frame, a portion of which is shaped to conform to the scalloped configuration of the normal circumference of an arterial heart valve annulus.

#### Summary of the Invention

**[0015]** The present invention provides improved prosthetic heart valves that can be implanted in a minimally-invasive manner, but which also has aspects that make it useful for conventional surgeries. The valves and im-

plant tools and methods described herein provide a highly adaptive and simple to use endovascular delivery option for cardiac surgeons or cardiologists because of features that facilitate implantation. The valve is designed to be expelled from a delivery tube in an implant area and then expanded and/or positioned to contact the surrounding tissue without additional anchoring structures. Further, the valve and implant tools permit repositioning and even recollapse of the valve if needed.

**[0016]** A first aspect of the invention is a collapsible prosthetic heart valve that has a collapsible leaflet frame, three separate, flexible leaflets attached to the leaflet frame, and three cusp positioners rigidly fixed with respect to the leaflet frame. The leaflet frame has three cusp regions intermediate three commissure regions, the three cusp regions being positioned at an inflow end of the leaflet frame and circumferentially about a flow axis defined within the support frame. The three commissure regions are positioned at an outflow end of the leaflet frame and circumferentially about the flow axis. Each flexible leaflet has an arcuate cusp edge opposite a free edge and a pair of commissure edges therebetween. The leaflets attach around the leaflet frame with the cusp edge of each leaflet extending along one of the cusp regions, and a commissure edge of each leaflet meeting a commissure edge of an adjacent leaflet at one of the commissure regions. The three cusp positioners are rigidly fixed with respect to the leaflet frame and are disposed circumferentially about the flow axis, each cusp positioner being located at the outflow end of the leaflet frame and intermediate two of the commissure regions of the leaflet frame.

**[0017]** Each cusp positioner of the heart valve support frame desirably has a U-shape with an apex of the U-shape pointing toward the outflow end of the support frame and two legs of the U-shape pointing towards the inflow end. Each of the two legs of each U-shaped cusp positioner may be rigidly fixed to the continuous leaflet frame at a location approximately midway between a cusp region and a commissure region thereof. An anti-migration member such as an elongated section terminating in an enlarged and rounded head can be rigidly fixed to each cusp positioner to project therefrom. The cusp positioners may flare outwardly from the rest of the support frame to better contact surrounding tissue.

**[0018]** The support frame further may include three cusp connectors rigidly fixed with respect to the leaflet frame and disposed circumferentially about the flow axis. Each cusp connector is located at the inflow end of the support frame and intermediate two of the cusp regions of the leaflet frame. Each cusp connector desirably has a U-shape with an apex of the U-shape pointing toward the inflow end of the support frame and two legs of the U-shape pointing toward the outflow end. In a preferred embodiment, the leaflet frame, cusp positioners, and cusp connectors are formed integrally as a single piece, and the three cusp positioners and three cusp connectors define a continuous, undulating shape that generally

mimics the shape of the leaflet frame but is rotated 60° about the flow axis therefrom.

**[0019]** The heart valve may incorporate the aforementioned features of the support frame, for example a leaflet frame with a continuous, undulating shape that mimics the natural fibrous structure of an aortic valve, cusp connectors, and anti-migration members on each cusp positioners. Desirably, an inflow periphery of the heart valve is defined along alternating and rigidly fixed cusp regions and cusp connectors. The inflow periphery may have an external fabric covering, and the heart valve may further include a fabric panel defining an exterior surface of the heart valve between each pair of cusp positioner and cusp connector. Preferably, the leaflet frame has a fabric covering along substantially its entire length, the fabric covering defining a flange, and wherein the arcuate cusp edges of the flexible leaflets attach to the fabric covering flange. The fabric covering flange may project generally outward from the leaflet frame such that the cusp edges of the flexible leaflets extend radially outward past and underneath the leaflet frame to be sewn to the fabric covering flange. Each flexible leaflet may have a pair of tabs extending on either side of its free edge, wherein two tabs of adjacent flexible leaflets meet and pass together to the outside of the adjacent commissure region of the leaflet frame and are attached thereto using sutures through the tabs.

#### Brief Description of the Drawings

##### **[0020]**

Fig. 1 is a partial view of a patient's heart generally vertically section through the left ventricle and associated heart valves, and illustrating the implantation approach of a catheter-based prosthetic valve of the present invention;

Fig. 2A is vertical section view through an aortic annulus and an exemplary prosthetic heart valve of the present invention implanted therein;

Fig. 2B is a top plan view of the implanted prosthetic heart valve of Fig. 2A;

Figs. 3A-3C are perspective, top plan, and bottom plan views, respectively, of the prosthetic heart valve of Fig. 2A;

Fig. 4 is a plan view of a prosthetic heart valve support frame of the present invention in a two-dimensional blank form prior to conversion to three-dimensional final form;

Fig. 5 is a perspective view of the prosthetic heart valve support frame of Fig. 4 in its three-dimensional final form with a leaflet frame and cusp positioners;

**[0021]** Figs. 5A and 5B are views of a portion of the three-dimensional heart valve support frame of Fig. 5 showing alternative cusp positioner configurations;

**[0022]** Fig. 6A is an elevational view of a partially assembled prosthetic heart valve as in Figs. 3A-3C;

**[0023]** Fig. 6B is an elevational view of the prosthetic heart valve of Fig. 6A fully assembled;

**[0024]** Fig. 7 is a plan view of an exemplary leaflet used in the prosthetic heart valves of the present invention;

5 **[0025]** Fig. 8 is a partial sectional view of a commissure region of the exemplary prosthetic heart valve taken along line 8-8 of Fig. 3B;

**[0026]** Fig. 9 is a sectional view through a portion of the support frame of the exemplary prosthetic heart valve, taken along line 9-9 of Fig. 8;

**[0027]** Fig. 10 is a sectional view through a commissure tip region of the exemplary prosthetic heart valve, taken along line 10-10 of Fig. 8;

10 **[0028]** Fig. 11 is a schematic perspective view of a prosthetic heart valve support frame of the present invention being loaded into a delivery catheter,

**[0029]** Fig. 12 is a perspective view of the support frame after having been loaded into a delivery catheter,

**[0030]** Figs. 13A-13B are perspective and elevational views of an exemplary compressible/expandable heart valve holder attached to a prosthetic heart valve of the present invention;

15 **[0031]** Fig. 14 is a perspective view of the expulsion of an assembled prosthetic heart valve and holder as in Figs. 13A and 13B from the distal end of a delivery catheter,

**[0032]** Fig. 15 is a bottom plan view of an exemplary compressible/expandable heart valve holder of the present invention;

20 **[0033]** Fig. 16 is a plan view of a multi-armed flexible portion of the holder of Fig. 15; and

**[0034]** Figs. 17A-17B are two views of a rigid portion of the holder of Fig. 15.

#### 35 Description of the Preferred Embodiments

**[0035]** The present invention provides an improved minimally invasive (MIS) valve support frame, MIS valve, and methods of construction and delivery as described herein and shown in the accompanying drawings.

40 **[0036]** The invention pertains primarily to flexible leaflet heart valves and internal support frames, which are also referred to in the art as stents or wireforms. As mentioned above, the flexible leaflets can be formed from biological (e.g., bovine pericardium) or synthetic material. In this context, a "support frame" for a flexible leaflet heart valve provides the primary internal structural support for the leaflets, and substantially mimics the natural fibrous skeleton of the respective valve annulus. More specifically, each of the leaflets has an outer edge that is coupled to a portion of the support frame such that its inner edge is free to move within the orifice area of the valve, thus providing the opening and closing surfaces thereof. A biological xenograft valve can be used to provide the flexible leaflets in the valves of the present invention, though the internal support frame is particularly suited to receive individual leaflets.

50 **[0037]** The leaflet frames of the present invention have

a continuous, undulating shape with three arcuate or U-shaped cusp regions on the inflow end separated by three upstanding and generally axially-oriented arcuate or U-shaped commissure regions on the outflow end. Around the circumference of the leaflet frame, the shape has an alternating structure of cusp-commissure-cusp-commissure cusp-commissure, and generally describes a conical surface of revolution with the three commissures on the outflow end of the valve being closer together than the three cusps. Some support frames may alternatively describe a tubular surface of revolution about an axis. The cusp regions and commissure regions are evenly distributed about a flow axis through the support frame, and therefore the three cusp regions are 120° apart from each other, and each of the three commissure regions is 120° apart from the next and 60° from the adjacent cusp regions.

**[0038]** The term "continuous" to describe the heart valve leaflet frame means that a single continuous and closed-shape line (i.e., loop) can be drawn following the sequential cusp and commissure regions, and "undulating" refers to the serpentine or alternating sinusoidal character of the line. More generally, a continuous, undulating heart valve leaflet frame approximates the shape of the natural fibrous tissue around the aortic valve annulus so as to mimic that natural support structure for optimum functionality of the prosthetic leaflets.

**[0039]** The present invention primarily pertains to prosthetic heart valves suitable for minimally invasive delivery and implantation. Such minimally invasive valves are capable of being compressed or collapsed into a small profile and delivered through a catheter or cannula (a tube) to the site of implantation for remote expansion and anchoring thereto. It should be understood, however, that certain aspects of the invention described herein are beneficial for prosthetic heart valves in general, and thus not all of the claims should be construed to require a minimally invasive valve.

**[0040]** Fig. 1 depicts a portion of a heart of a patient with the left ventricle LV, aortic valve AV, mitral valve MV, and ascending aorta AA shown in section. A delivery catheter or tube 20 is seen in position just prior to complete expulsion and expansion of a prosthetic heart valve 22 from a distal end thereof for implant at the aortic valve AV annulus. The aortic valve AV leaflets L may first be excised prior to implant of the valve 22, or more preferably the leaflets L remain in place and are expanded outward and compressed against the lumen of the aortic valve AV annulus upon expansion of the valve. The distal end of the delivery tube 20 may optionally be stabilized by a balloon 24 (shown in phantom) inflated against the lumen of the ascending aorta AA, or through other means. The delivery tube 20 is preferably inserted in the vasculature of the patient using a larger diameter introducer 26 through a peripheral vessel such as the femoral artery or femoral vein. Alternatively, the peripheral vessel may be the internal jugular vein, the subclavian artery, the axillary artery, the abdominal aorta, the descending aor-

ta, or any other suitable blood vessel. The introducer 26 may be inserted by surgical cut down or percutaneously using the Seldinger technique.

**[0041]** Figs. 2A and 2B illustrate the prosthetic heart valve 22 implanted at the aortic valve AV annulus. The heart valve 22 includes three cusps 30 on an inflow end (one of which is not visible) and three commissures 32 on an outflow end. The direction of blood flow BF is indicated with an arrow in the ascending aorta AA. The natural leaflets are desirably compressed against the lumen of the aortic valve annulus by the prosthetic heart valve 22, as seen in Fig. 2B. The valve 22 is oriented about a flow axis such that the commissures 32 are generally aligned with the native commissures C, while the cusps (not shown but intermediate the commissures 32) are generally aligned with the natural cusps/leaflets L. The heart valve 22 contacts the lumen wall of the aortic valve AV annulus and desirably retains its position due to friction therebetween. In this regard, the heart valve 22 expands from its delivery configuration shown in Fig. 1 to the expanded configuration in Figs. 2A and 2B.

**[0042]** The valve 22 contacts the lumen wall around the entire periphery of the inflow end thereof and in certain areas adjacent to the inflow periphery, as will be explained below. The inflow periphery is defined by the lower ends of the cusps 30 as well as by the lower ends of three cusps connectors 40 that extend between and fill the gaps between the cusps 30. Additionally, the heart valve 22 includes three cusp positioners 42, two of which are visible in Fig. 2A, that are rigidly fixed with respect to an internal valve support frame and are each located generally at the outflow end of the valve intermediate two of the commissures 32. With reference to Fig. 2B, the cusp positioners 42 are evenly distributed about a central flow axis 44, and when implanted align with the native leaflets L. The cusp positioners 42 preferably extend radially farther outward than the commissures 32 and compress the leaflets L against the natural sinus cavities formed just above the aortic valve AV annulus. Coronary ostia CO open from two of the three sinus cavities, as seen in Fig. 2A, and the cusp positioners 42 are sized and placed by the operator to avoid occluding flow through the coronary ostia CO. The advantageous structure and function of these cusp positioners 42 will be more fully explained below.

**[0043]** With reference now to Figs. 3A-3C, the exemplary prosthetic heart valve 22 will be more fully described. The shape of an internal support frame 50 seen in Fig. 5 generally governs the shape of the valve 22. As mentioned, the valve 22 includes the aforementioned cusps 30 and commissures 32 evenly distributed about a flow axis 44. The cusps 30 and cusp connectors 40 define a scalloped inflow periphery of the valve 22, while the outflow periphery is defined by the three commissures 32 and the three cusp positioners 42. The entire internal support frame 50 except for the cusp positioners 42 is covered over with one or more layers of material, the exterior layer of which is typically a fabric as shown



(but not numbered). The use of a fabric such as polyethylene terephthalate provides a matrix into which surrounding tissue can grow to help anchor the valve in place.

**[0044]** Three flexible leaflets 52 mount to the valve 22 in a trifoil configuration with free edges 53 thereof arranged to meet or coapt in the middle of the valve and provide one-way occlusion. An outer edge of each leaflet 52 attaches to the valve 22 between two of the commissures 32 and around one of the cusps 30. An exemplary structural attachment of the leaflets 52 to the internal support frame 50 will be described below.

**[0045]** As mentioned, each cusp connector 40 extends between two of the cusps 30. A panel of fabric or other material 54 covers an area between the inflow or lower edge of each cusp connector 40 and the corresponding commissures 32. Some of this panel of fabric 54 desirably contacts the lumen wall of the aortic valve AV annulus to help prevent leakage around the valve.

**[0046]** The exemplary cusp positioners 42 each have an inverted U-shape with an apex pointed toward the outflow end of the valve 22 and two legs extending generally toward the inflow end and connecting with the remainder of the valve. The term "U-shape" is intended to cover all configurations that have two legs and an apex therebetween. Other figurative descriptions such as V-shaped, bell-shaped, sinusoidal, arcuate, or the like are therefore encompassed by the term "U-shape". It is contemplated, however, that the cusp positioners 42 could assume other forms, such as a generally linear, cantilevered arm extending upward from the midpoint of each cusp 30. In whatever form, the cusp positioners 42 provide the valve 22 with three points of contact with the surrounding tissue that is midway between the three commissures 32 so as to help stabilize and anchor the valve in its implant position. Moreover, the cusp positioners 42 desirably perform the function of compressing the native leaflets L outward against the sinus cavities, at least in those procedures where the leaflets L are not excised.

**[0047]** The leaflets L in a diseased valve may be less than flexible, and indeed may be highly calcified. It is often considered preferable to avoid removing the leaflets L so as to avoid disturbing the calcification or other stenotic material that has built up around the leaflets. Therefore, the present invention desirably provides structure to compress the native leaflets L outward against the aortic wall sinus cavities and hold the leaflets in that position so as to avoid flapping and potentially interfering with blood flow through the prosthetic valve. The inverted U-shape of the cusp positioners 42 is believed to provide effective structure to both anchor the valve in the aortic valve AV annulus and also control, or corral, if you will, the obsolete native leaflets L. At the same time, the cusp positioners 42 are relatively minimal in total area so as to avoid unduly interfering with back flow of blood on the outflow side of each of the leaflets 52, or to the coronary ostia CO. Therefore, the cusp po-

sitioners 42 are desirably defined by relatively thin members, as shown, as opposed to walls or panels, or the like. Multiple cusp positioners 42 per valve cusp 30 are conceivable, though the total solid volume taken up by the cusp positioners should be kept to a minimum so as to minimize the risk of occluding the coronary ostia CO.

**[0048]** The axial height of the cusp positioners 42 relative to the commissures 32 is seen best in Fig. 2A (and in Fig. 6B). Preferably, the commissures 32 are slightly taller than the cusp positioners 42, although such an arrangement is not considered mandatory. The main consideration in the size of the cusp positioners 42 is to avoid occluding the coronary ostia CO. Therefore, as seen in Fig. 2A, the cusp positioners 42 contact the surrounding aortic valve AV lumen wall just below the coronary ostia CO. Of course, the anatomy of each patient differs slightly from the next, and the precise position of the coronary ostia CO cannot be predicted with absolute certainty. Furthermore, the final location of the cusp positioners 42 is dependent on the skill of the cardiac surgeon or cardiologist. In the ideal situation, however, the cusp positioners 42 are positioned just below and aligned circumferentially with the coronary ostia CO as seen in Figs. 2A and 2B.

**[0049]** Figs. 2B and 3B-3C illustrate the relative outward radial position of the cusp positioners 42 with respect to the commissures 32 therebetween, and with respect to the cusp connectors 40. As seen in the isolated view of the heart valve support frame 50 in Fig. 5, the cusp positioners 42 are angled or flared outward from the remainder of the support frame. This outward flaring helps ensure good contact between the apex of the cusp positioners 42 and the surrounding walls of the aortic valve AV sinus cavities. In this regard, the outer configuration of the heart valve 22 is designed to maximize contact with the aortic valve AV lumen wall both in the annulus and for a short distance into each sinus cavity. This extensive surface contact between the prosthetic valve 22 and the surrounding tissue may obviate the need for sutures, staples, sharp barbs or other such anchoring structure, although such structure could be used in conjunction with the valve. The valve 22 is merely expelled from the end of the delivery tube 20 (Fig. 1), expanded with or without assistance of a balloon, and held in place by frictional contact between the inflow periphery against the annulus, and between the cusp positioners 42 and the sinus cavities (or intervening native leaflets).

**[0050]** Each cusp positioner 42 further includes at least one anti-migration member 56 rigidly fixed thereto and designed to help anchor the support frame 50 to the surrounding tissue. In the illustrated embodiment, the anti-migration members 56 each preferably includes an elongated section 58 terminating in an enlarged and rounded head 60, the configuration thus somewhat resembling a spoon. The anti-migration member 56 desirably projects out of the plane defined by the associated cusp positioner 42, and may extend generally axially in the inflow direction from the apex thereof, as seen in Fig. 3A. When the valve 22 is implanted, the anti-migration members 56 are

designed to contact and become somewhat entrapped in the native leaflets. Therefore, the anti-migration members 56 act as a rounded barb of sorts to maintain the valve 22 in its implant position. The members 56 also may help prevent flapping of the native leaflets in the swirling blood flow. Numerous other configurations are contemplated, the general idea being that the anti-migration member 56 enhances the ability of the associated cusp positioner 42 to anchor to the surrounding tissue. In this regard, the term "anti-migration member" is meant to include any structure that enhances such anchoring, including both blunt and sharp structures (i.e., barbs).

**[0051]** Various procedures and apparatuses for converting a two-dimensional blank such as shown in Fig. 4 to the three-dimensional form of Fig. 5 are described in more detail in co-pending U.S. Patent Application Serial No. 10/251,651, filed September 20, 2002, and entitled continuous heart valve support frame and method of manufacture. In short, the process involves bending the two-dimensional blank 70 around a cylindrical or conical mandrel and altering the material so as to retain its three-dimensional shape. For example, various nickel-titanium alloys (Nitinol) may be easily bent around a mandrel and then set into that shape using heat treatments.

**[0052]** In an exemplary embodiment of the present invention, the internal support frame 50 of the valve 22 is made of a material that is highly flexible so as to permit maximum relative movement between the valve cusps and commissures, and in some cases to permit constriction into a small profile diameter for minimally invasive delivery to an implantation site. At the same time the support frame must possess a minimum amount of stiffness to provide the desired support to the leaflets. Therefore, there is a balance obtained between the requisite flexibility and stiffness.

**[0053]** The material for the internal support frame is desirably "elastic," which means that it has the capacity to rebound from imposed strain. Various NITINOL alloys are especially suitable for making the internal support frame of the present invention as in certain circumstances they are considered to be "superelastic." Other materials that may be used include ELGILOY, titanium, stainless-steel, even polymers, and similar expedients. These latter materials do not display superelasticity but are still elastic. Other materials may fit within this definition but they must be suitable for long-term implantation in the body.

**[0054]** The term "superelastic" (sometimes "pseudoelastic") refers to that property of some materials to undergo extreme strains (up to 8%) without reaching their failure stress limit. Some so-called shape memory alloys (SMAs) are known to display a superelastic phenomena or rubber-like behavior in which a strain attained beyond the elastic limit of the SMA material during loading is recovered during unloading. This superelastic phenomenon occurs when load is applied to an austenitic SMA article which first deforms elastically up to the yield point of the SMA material (sometimes referred to as the critical

stress). Upon the further imposition of load, the SMA material begins to transform into stress-induced martensite or "SIM." This transformation takes place at essentially constant stress, up to the point where the SMA material is completely transformed into martensite. When the stress is removed, the SMA material will revert back into austenite and the article will return to its original, preprogrammed programmed or memorized shape.

**[0055]** The support frame 50 is desirably constructed of a material that exhibits hysteresis in the elastic and/or superelastic region. "Hysteresis" indicates that when the material is strained beyond the "memory condition" (defined as unconstrained geometry) it produces a stress-strain curve that is different and higher than the stress-strain curve produced as the material attempts to return to its memory condition. An example of a material that exhibits such a hysteresis is NITINOL. The presence of this hysteresis implies that it requires a greater force to displace the material from its memory condition than the material exerts as it recovers to its memory condition.

**[0056]** When using NITINOL the shape set is done at a particular temperature for a period of time designed to ensure certain properties in the material. Namely, the martensitic transition temperature is desirably less than room temperature and the austenitic transition temperature is desirably less than body temperature. For instance, the temperature below which the material is in martensitic form is around 0-5° C, while the temperature above which the material is in austenitic form is around 20-25° C. When the material is shape set in this way, the heart valve 22 can be cooled, such as in an ice bath, just prior to implant to change the crystalline structure of the support frame 50 to martensite and create high flexibility so as to enable compaction thereof into a small diameter delivery profile. After implant and expansion, the temperature rises from body heat above the austenitic transition temperature and thus the support frame 50 possesses the desired degree of stiffness to properly support the leaflets.

**[0057]** The support frame 50 (and blank 70) includes a leaflet frame 72 defined by three cusp regions 74 intermediate three commissure regions 76. In Fig. 4 the leaflet frame 72 in the blank 70 exhibits a three-leaf clover shape, while in Fig. 5 the leaflet frame 72 has a continuous, undulating shape as described above. A second three-leaf clover shape can be seen in Fig. 4 formed by the three cusp connectors 40 and three cusp positioners 42. When bent into the three-dimensional configuration of Fig. 5, two continuous, undulating shapes can be seen oriented 60° with respect to one another about the central flow axis. Each cusp connector 40 includes an apex 80 and a pair of legs 82 that rigidly attach to the leaflet frame 72 at junction points 84. Likewise, each cusp positioner 42 includes an apex 90 and a pair of legs 92 that rigidly attach to the leaflet frame 72 at junction points 94. In the preferred and illustrated embodiment, the junction points 84 and 94 are coincident.

**[0058]** Figs. 5A and 5B show alternative cusp position-

er configurations for the three-dimensional heart valve support frame 50 of Fig. 5. As mentioned above, the anti-migration members facilitate anchoring of the support frame 50 to the surrounding anatomy, and prevent axial and rotational movement of the valve 22. The anti-migration members 56 shown in Fig. 5 project generally axially in the inflow direction from the apex 90 of each cusp positioner 42. In Fig. 5A, a second anti-migration member 57 projects generally axially in the outflow direction from the apex 90 of each cusp positioner 42. In Fig. 5B, there are multiple anti-migration members 56 extending generally axially in the inflow direction. Various combinations, placements and orientations of these examples are contemplated, and the examples should not be considered limiting.

**[0059]** Fig. 6A shows the valve 22 almost completely assembled, but without the aforementioned cloth covers 54 that are seen in the fully assembled valve of Fig. 6B. The covers 54 help prevent leakage of blood around the implanted valve 22, and specifically in the areas between the each pair of cusps 30.

**[0060]** Fig. 7 illustrates an exemplary leaflet 52 in plan view. The free edge 50 is shown as linear, but may also be arcuate, angled, trapezoidal, or other configuration. Each leaflet includes a pair of opposed generally rectangular tabs 100 at either end of the free edge 53. An arcuate cusp edge 102 extends between the tabs 100 and opposite the free edge 53. The tabs 100 and arcuate cusp edge 102 are secured to the valve 22, and specifically along the contours of the leaflet frame 72 seen in Fig. 5.

**[0061]** Fig. 8 is an enlarged cutaway view of one of the commissures 32 of the valve 22 taken along line 8-8 of Fig. 3B and showing the internal construction thereof. The commissure region 76 of the leaflet frame 72 tapers down in the outflow direction to a closed tip 104. Attachment flanges 106 are formed adjacent the tip 104 and desirably include a plurality of assembly holes 108 sized to permit passage of sutures therethrough. The adjacent leaflets 52 come together in the commissure regions 76 and the tabs 100 thereof are folded away from each other on the exterior of the flanges 106.

**[0062]** As seen in Fig. 9, the cusp edge 102 of each leaflet 52 attaches with sutures 110 to a cloth flange 112 of a tubular fabric cover 114 around the leaflet frame 72. This configuration causes tensile forces imparted by the leaflets 52 to be transferred as much as possible to the frame 72 rather than being primarily borne by the attachment sutures 110.

**[0063]** Fig. 10 shows the attachment structure at the commissure tip 104, and specifically illustrates sutures 120 passing through the fabric cover 114, through the assembly holes 108, and through the folded leaflet tabs 100. A second suture 122 passes through the cloth flange 112, the leaflet tab 100, and cloth covers 54 (also shown in Fig. 6B). Because each of the leaflets 52 includes the tab 100 that extends to the outside of the leaflet frame 72, high forces that are seen with closing of the valve are

less likely to pull the sutures 120 through the tabs. That is, the construction shown in Fig. 10 causes tensile forces imparted by the leaflets 52 to be transferred as much as possible from the sutures 120, 122 to the frame 72, thus helping to prevent tearing of the flexible leaflets and rendering the valve 22 more durable.

**[0064]** Figs. 11 and 12 schematically illustrate a technique for loading a prosthetic heart valve of the present invention into a delivery tube. For the sake of clarity, only the support frame 50 is shown being loaded into the delivery tube 20. A plurality of sutures or other such flexible members or filaments 130 are shown looped through each of the commissure regions 76 of the support frame 50. These filaments 130 extend into the distal end of the delivery tube 20 and through its lumen to a proximal end (not shown) where they are connected to a tensioning device. In actual use, the filaments 130 would be threaded through the commissures 32 of the valve 22, avoiding the flexible leaflets. A loading adapter 132 couples to the distal end of the delivery tube 20. The adapter 132 includes an inner funnel-shaped opening 134. Tension on the filaments 130 pulls the commissures 32 of the valve into the funnel-shaped opening 134 which gradually compresses the valve into a diameter smaller than the lumen of the delivery tube 20. Once the valve 22 is positioned fully within the delivery tube 20, as seen in Fig. 12, the filaments 130 and adapter 132 are removed.

**[0065]** Figs. 13-17 illustrate a minimally invasive holder for use with the prosthetic heart valves of the present invention. Figs. 13A and 13B show the holder 150 attach to the heart valve 22 as described above. The holder 150 includes a multi-armed flexible portion 152 and a rigid portion 154 (seen in Figs. 17A-17B). The flexible portion 152 includes a plurality, at least three, but preferably six flexible members or arms 156 extending outward from a central circular disk 158. Each of the arms 156 terminates in a rounded end having an attachment aperture 160. The arms 156 are distributed evenly about the circumference of the circular disk 158, and are arrayed to attach to each of the commissures 32 and cusp positioners 42 of the valve 22. Releasable sutures 162 or other such attachment structure are used for this purpose.

**[0066]** Fig. 14 shows the assembled holder 150 and valve 22 emerging from the distal end of a delivery tube 20. Prior to this stage, the flexible members or arms 156 are oriented generally axially within the tube 20 with the valve 22 also collapsed and having its outflow prongs coupled to the distal ends of the arms 156. The arms 156 of the holder 150 are sufficiently flexible to be compressed into the small profile required for delivery through the delivery tube 20. In this regard, the flexible portion 152 is desirably made of Nitinol. A handle 170 which may be flexible or rigid attaches to the holder 150 for manipulation thereof. Displacing the handle 170 in a distal direction with respect to the tube 20 therefore expels the valve/holder combination and the resiliency of the valve 22 and holder arms 156 causes them to spring outward. It should be understood that other designs of the holder

150 may be utilized, such as replacing the spring-like arms 156 with rigid members that are hinged and spring-biased.

**[0067]** Figs. 15-17 illustrate specifics of the exemplary flexible portion 152 and rigid portion 154. In a relaxed configuration, the flexible portion 152 is planar, and may be cut from a sheet of Nitinol. The rigid portion 154 includes a proximal face 180 that is sized approximately the same as the circular disk 158, and small enough to fit within the delivery tube 20. A central threaded bore 182 opens to the proximal face 180 for receiving the handle 170. Fig. 15 illustrates a number of sutures 162 threaded through the holder 150 and used to couple the holder to the six outflow prongs of the prosthetic heart valve 22. Desirably, these sutures 162 are anchored with respect to the holder and each one passes over a cutting guide in the holder such that the suture may be severed along its midpoint resulting in two free ends that can be pulled free of the valve.

**[0068]** The holder 150 is sufficiently flexible to be compressed into a small profile and passed through the delivery tube 20. At the same time, the flexible portion 152 and multiple flexible arms 156 have a sufficient degree of torsional strength to permit the operator to rotate the valve 22 during the implant procedure. Furthermore, the arms 156 are shaped to contact the distal mouth of the delivery tube 20 when the assembly is pulled toward the tube which, due to their radial stiffness, causes the arms to bend back toward their axial orientation within the tube. Since the distal ends of the arms are coupled to at least three of the outflow prongs of the prosthetic heart valve 22, the valve constrict accordingly. Constriction of the valve 22 after having been fully expelled from the end of the delivery tube and expanded permits repositioning of the valve 22. That is, the cusp positioners 42 are designed to contact the sinuses cavities or aortic wall after the valve 22 expands, and the retraction/constriction option afforded by the holder 150 may be necessary to disengage the cusp positioners from the surrounding tissue to reposition or re-orient the valve. Furthermore, the valve 22 can be completely collapsed and retracted back into the delivery tube to permit removal in case the surgeon or cardiologist deems the valve unsuitable for whatever reason.

#### Method of Use

**[0069]** Prior to implant, the cardiac surgeon or cardiologist measures the aortic valve AV annulus using appropriate sizers, minimally invasive or not as the case may be, a number of which are available and which will not be further described herein. The correctly sized valve is then selected and compressed into the delivery catheter or tube 20, such as with the use of the loading adapter 132 having the inner funnel-shaped opening 134 as seen in Fig. 11. To facilitate this loading step, the inner support frame 50 of the valve 22 must be able to withstand high stresses without failure. One method is to form the sup-

port frame 50 from a material that has superelastic properties, for instance a Nitinol that has a martensitic transition temperature of less than about 5° C can be immersed in an ice bath to change its crystalline structure to martensite, which is a superelastic phase. Once loaded into the delivery tube 20, the support frame 50 will not revert back to its original shape upon a temperature rise and thus does not exert undue outward force on the tube. The heart valve 22 may be loaded around an inflation balloon, but for the sake of a small profile the balloon is used after expulsion of the valve from the tube at the implantation site.

**[0070]** With reference again to Fig. 1, the delivery tube 20 is seen in position just prior to complete expulsion and expansion of the prosthetic heart valve 22 from a distal end thereof for implant at the aortic valve AV annulus. The distal end of the delivery tube 20 may optionally be stabilized by a balloon 24 (shown in phantom) inflated against the lumen of the ascending aorta AA, or through others means. The delivery tube 20 is preferably inserted in the vasculature of the patient using a larger diameter introducer 26 through a peripheral vessel such as the femoral artery or femoral vein. Alternatively, the peripheral vessel may be the internal jugular vein, the subclavian artery, the axillary artery, the abdominal aorta, the descending aorta, or any other suitable blood vessel. The introducer 26 may be inserted by surgical cut down or percutaneously using the Seldinger technique.

**[0071]** The prosthetic heart valve 22 is expelled from the delivery tube 20 by relative movement therebetween - i.e., by pushing the valve from the tube or by retracting the tube from around the valve. The valve 22 desirably self-expands into contact with the surrounding lumen wall, but may also be assisted with an inflation balloon or other such physical expander.

**[0072]** With reference to Figs. 2A and 2B, the cusps positioners 42 help guide the prosthetic heart valve 22 into position in the aortic valve AV annulus. As mentioned above, the cusp positioners 42 desirably flare outward from the rest of the valve structure and are thus configured to contact the sinuses of the aortic valve AV while the cusps 30 are sized to fit within the annulus. In accordance with one method of implantation, the surgeon or cardiologist expels the heart valve 22 below (i.e., toward the left ventricle) its optimum implant position, and then axially displaces the valve upward into the desired position. Stated another way, the heart valve 22 is expanded in a location that is inferior to a final implant position such that the cusp positioners 42 contact the surrounding aortic annulus, and the valve is then repositioned by displacing the valve in a superior direction to a final implant position. As the valve 22 ascends, the cusp positioners 42 spring outward into the three valve sinuses and help rotationally orient the valve. That is, the sinuses channel the cusp positioners 42 and correct any rotational misalignment. Finally, the valve 22 is implanted with the cusp positioners 42 in the sinus cavities (preferably below the coronary ostia CO) and the cusps 30 and cusp

connectors 40 forming a scalloped yet continuous contact wall against the aortic valve AV annulus or root.

**[0073]** As mentioned, a physical expander (e.g., balloon) may be used to radially outwardly expand the valve 22 (including the internal support frame 50) beyond its self-expanded diameter so that it is firmly anchored in place. A prosthetic valve possessing hysteresis that is held in a reduced (first or constrained) diameter will exert an outward radial force that is less than the force at which it will resist an inward radial force. Therefore, if deployed in situ, the device is not expected to exert enough force on the vessel wall to expand to the desired diameter. However, if the expansion is assisted by means of a balloon or other physical expander, the hysteresis of the material will allow it to better maintain its diameter once that diameter is achieved. This is unlike a self-expanding device that relies solely on the outward radial force of the device to achieve its desired diameter. It is also unlike balloon expanded devices that rely on a balloon to plastically deform the device into the desired diameter. Although it is conceivable that a balloon or other physical expander could be used in a self-expanding device made of a material that does not display a hysteresis, the benefits would not be as great.

**[0074]** It will be appreciated that the invention has been described hereabove with reference to certain examples or preferred embodiments as shown in the drawings. Various additions, deletions, changes and alterations may be made to the above-described embodiments and examples, and it is intended that all such additions, deletions, changes and alterations be included within the scope of the following claims.

#### Claims

1. A collapsible prosthetic heart valve (22), comprising:

a collapsible leaflet frame having three cusp regions (30) intermediate three commissure regions (32), the three cusp regions being positioned at an inflow, end of the leaflet frame and circumferentially about a flow axis defined within the leaflet frame, the three commissure regions being positioned at an outflow end of the leaflet frame and circumferentially about the flow axis; three separate, flexible leaflets (52) attached to the leaflet frame, each leaflet having an arcuate cusp edge opposite a free edge and a pair of commissure edges therebetween, the leaflets being attached around the leaflet frame with the cusp edge of each leaflet extending along one of the cusp regions, and a commissure edge of each leaflet meeting a commissure edge of an adjacent leaflet at one of the commissure regions; and three cusp positioners (42) rigidly fixed with respect to the leaflet frame and disposed circum-

ferentially about the flow axis, each cusp positioner being located at the outflow end of the leaflet frame and intermediate two of the commissure regions of the leaflet frame.

2. The heart valve of Claim 1, wherein each cusp positioner has a U-shape with an apex of the U-shape pointing toward the outflow end of the leaflet frame and two legs of the U-shape pointing toward the inflow end.
3. The heart valve of Claim 2, wherein each of the two legs of each U-shaped cusp positioner is rigidly fixed to the continuous leaflet frame at a location approximately midway between a cusp region and a commissure region thereof.
4. The heart valve of Claim 2, further including an anti-migration member (56) rigidly fixed to each cusp positioner and projecting therefrom.
5. The heart valve of Claim 1, wherein the heart valve further includes three cusp connectors (40) rigidly fixed with respect to the leaflet frame and disposed circumferentially about the flow axis, each cusp connector being located at the inflow end of the leaflet frame and intermediate two of the cusp regions of the leaflet frame.
6. The heart valve of Claim 5, wherein each cusp connector has a U-shape with an apex of the U-shape pointing toward the inflow end of the leaflet frame and two legs of the U-shape pointing toward the outflow end.
7. The heart valve of Claim 6, wherein the leaflet frame, cusp positioners, and cusp connectors are formed integrally as a single piece, and wherein the three cusp positioners and three cusp connectors define a continuous, undulating shape that generally mimics the shape of the leaflet frame but is rotated 60° about the flow axis therefrom.
8. The heart valve of Claim 5, wherein an inflow periphery of the heart valve is defined along the alternating and rigidly fixed cusp regions and cusp connectors.
9. The heart valve of Claim 8, wherein the inflow periphery has an external fabric covering, and wherein the heart valve further includes a fabric panel defining an exterior surface of the heart valve between each pair of cusp positioner and cusp connector.
10. The heart valve of Claim 1, wherein the leaflet frame has a fabric covering along substantially its entire length, the fabric covering defining a flange, wherein the arcuate cusp edges of the flexible leaflets attach to the fabric covering flange.

11. The heart valve of Claim 10, wherein the fabric covering flange projects generally outward from the leaflet frame and the cusp edges of the flexible leaflets extend radially outward past and underneath the leaflet frame and are sewn to the fabric covering flange.
12. The heart valve of Claim 1, wherein each flexible leaflet has a pair of tabs extending on either side of its free edge, wherein two tabs of adjacent flexible leaflets meet and pass together to the outside of the adjacent commissure region of the leaflet frame and are attached thereto using sutures through the tabs.

### Patentansprüche

1. Zusammenfaltbare prothetische Herzklappe (22), umfassend:

einen zusammenfaltbaren Segelblattrahmen mit drei Segelbereichen (30) zwischen drei Kommissurbereichen (32), wobei die drei Segelbereiche an einem Zuströmungsende des Segelblattrahmens und zirkumferenziell um eine Strömungsachse positioniert sind, die innerhalb des Stützrahmens definiert ist, wobei die drei Kommissurbereiche an einem Ausströmungsende des Segelblattrahmens und zirkumferenziell um die Strömungsachse positioniert sind;

drei separate, flexible Segelblätter (52), die am Segelblattrahmen befestigt sind, wobei jedes Segelblatt einen bogenförmigen Segelrand gegenüber einem freien Rand und ein Paar Kommissurränder dazwischen aufweist, wobei die Segelblätter um den Segelblattrahmen herum befestigt sind, wobei sich der Segelrand jedes Segelblatts entlang einem der Segelbereiche erstreckt und ein Kommissurrand jedes Segelblatts mit einem Kommissurrand eines angrenzenden Segelblatts an einem der Kommissurbereiche zusammentrifft; und

die drei Segelpositionierer (42) in Bezug auf den Segelblattrahmen starr fixiert und zirkumferenziell um die Strömungsachse herum angeordnet sind, wobei jeder Segelpositionierer am Ausströmungsende des Segelblattrahmens und zwischen zwei der Kommissurbereiche des Segelblattrahmens liegend positioniert ist.

2. Herzklappe nach Anspruch 1, wobei jeder Segelpositionierer eine U-Form aufweist, wobei ein Scheitel der U-Form in Richtung des Ausströmungsendes des Segelblattrahmens zeigt und zwei Schenkel der U-Form in Richtung des Zuströmungsendes zeigen.
3. Herzklappe nach Anspruch 2, wobei jeder der zwei

Schenkel jedes U-förmigen Segelpositionierers starr am kontinuierlichen Segelblattrahmen an einer Stelle fixiert ist, die ca. auf dem halben Weg zwischen einem Segelbereich und einem Kommissurbereich davon liegt.

4. Herzklappe nach Anspruch 2, die weiter ein Antimitigationselement (56) einschließt, das starr an jedem Segelpositionierer befestigt ist und daraus hervorsticht.

5. Herzklappe nach Anspruch 1, wobei die Herzklappe weiter drei Segelpositionierer (40) einschließt, die in Bezug auf den Segelblattrahmen starr fixiert und zirkumferenziell um die Strömungsachse herum angeordnet sind, wobei jeder Segelverbinder am Zuströmungsende des Segelblattrahmens und zwischen zwei der Segelbereiche des Segelblattrahmens liegend positioniert ist.

6. Herzklappe nach Anspruch 5, wobei jeder Segelverbinder eine U-Form aufweist, wobei ein Scheitel der U-Form in Richtung des Zuströmungsendes des Segelblattrahmens zeigt und zwei Schenkel der U-Form in Richtung des Ausströmungsendes zeigen.

7. Herzklappe nach Anspruch 6, wobei der Segelblattrahmen, die Segelpositionierer und Segelverbinder integral als ein Einzelstück gebildet sind und, wobei die drei Segelpositionierer und drei Segelverbinder eine kontinuierliche, undulierende Form definieren, die generell die Form des Segelblattrahmens nachahmt, aber 60° um die Strömungsachse davon rotiert ist.

8. Herzklappe nach Anspruch 5, wobei eine Zuströmungsperipherie der Herzklappe entlang der abwechselnden und starr befestigten Segelbereiche und Segelverbinder definiert ist.

9. Herzklappe nach Anspruch 8, wobei die Zuströmungsperipherie eine externe Stoffbedeckung aufweist und, wobei die Herzklappe weiter eine Stoffbahn einschließt, die eine externe Oberfläche der Herzklappe zwischen jedem Paar von Segelpositionierern und Segelverbinder definiert.

10. Herzklappe nach Anspruch 1, wobei der Segelblattrahmen eine Stoffbedeckung entlang im Wesentlichen seiner ganzen Länge aufweist, wobei die Stoffbedeckung einen Flansch definiert, wobei sich die bogenförmigen Segelränder der flexiblen Segelblätter am Flansch befestigen, der den Stoff abdeckt.

11. Herzklappe nach Anspruch 10, wobei der Stoff abdeckende Flansch generell vom Segelblattrahmen nach außen hervorragt und sich die Segelränder der flexiblen Segelblätter radial nach außen gerichtet,

vorbei am und unterhalb des Segelblattrahmens erstrecken und an den Stoff abdeckenden Flansch genäh sind.

12. Herzklappe nach Anspruch 1, wobei jedes flexible Segelblatt ein Paar Lappen aufweist, die sich auf beiden Seiten seines freien Randes erstrecken, wobei zwei Lappen von angrenzenden flexiblen Segelblättern aneinanderstoßen und zusammen zur Außenseite des angrenzenden Kommissurbereichs des Segelblattrahmens passieren und unter Verwendung von Nähten durch die Lappen daran befestigt werden.

#### Revendications

1. Valve cardiaque prothétique repliable (22), comprenant :

une armature de feuillets repliable ayant trois régions de cuspide (30) à l'intermédiaire de trois régions de commissure (32), les trois régions de cuspide étant positionnées à une extrémité de flux entrant de l'armature de feuillets et sur la circonférence autour d'un axe de flux défini à l'intérieur de l'armature de support, les trois régions de commissure étant positionnées à une extrémité de flux sortant de l'armature de feuillets et sur la circonférence autour de l'axe de flux;

trois feuillets flexibles, séparés (52) attachés à l'armature de feuillets, chaque feuillet ayant un bord de cuspide arqué à l'opposé d'un bord libre et une paire de bords de commissure entre eux, les feuillets étant attachés autour de l'armature de feuillets avec le bord de cuspide de chaque feuillet s'étendant le long de l'une des régions de cuspide et un bord de commissure de chaque feuillet rejoignant un bord de commissure d'un feuillet adjacent à l'une des régions de commissure; et

trois positionneurs de cuspidés (42) rigidement fixés par rapport à l'armature de feuillets et disposés sur la circonférence autour de l'axe de flux, chaque positionneur de cuspide étant situé à l'extrémité de flux sortant de l'armature de feuillet et à l'intermédiaire de deux des régions de commissure de l'armature de feuillets.

2. Valve cardiaque selon la revendication 1, dans laquelle chaque positionneur de cuspide a une forme en U avec un sommet de la forme en U pointant vers l'extrémité de flux sortant de l'armature de feuillets et les deux jambes de la forme en U pointant vers l'extrémité de flux entrant.
3. Valve cardiaque selon la revendication 2, dans la-

quelle chacune des deux jambes de chaque positionneur de cuspide en forme de U est rigidement fixée à l'armature de feuillets continue à un emplacement approximativement à mi-chemin entre une région de cuspide et une région de commissure de celle-ci.

4. Valve cardiaque selon la revendication 2, comprenant en outre un membre anti-migration (56) rigidement fixé à chaque positionneur de cuspide et faisant saillie de là.

5. Valve cardiaque selon la revendication 1, où la valve cardiaque comprend en outre trois connecteurs de cuspidés (40) rigidement fixés par rapport à l'armature de feuillets et disposés sur la circonférence autour de l'axe de flux, chaque connecteur de cuspide étant situé à l'extrémité de flux entrant de l'armature de feuillets et à l'intermédiaire de deux des régions de cuspide de l'armature de feuillets.

6. Valve cardiaque selon la revendication 5, dans laquelle chaque connecteur de cuspide a une forme en U avec un sommet de la forme en U pointant vers l'extrémité de flux entrant de l'armature de feuillets et les deux jambes de la forme en U pointant vers l'extrémité de flux sortant.

7. Valve cardiaque selon la revendication 6, dans laquelle l'armature de feuillets, les positionneurs de cuspidés et les connecteurs de cuspidés sont formés intégralement en une seule pièce, et dans laquelle les trois positionneurs de cuspidés et les trois connecteurs de cuspidés définissent une forme continue, ondulée qui imite généralement la forme de l'armature de feuillets mais qui est tournée à 60° autour de l'axe de flux de celle-ci.

8. Valve cardiaque selon la revendication 5, dans laquelle une périphérie de flux entrant de la valve cardiaque est définie le long des régions de cuspide et des connecteurs de cuspidés alternés et rigidement fixés.

9. Valve cardiaque selon la revendication 8, dans laquelle la périphérie de flux entrant a un recouvrement extérieur en étoffe, et où la valve cardiaque comprend en outre un panneau en étoffe définissant une surface extérieure de la valve cardiaque entre chaque paire de positionneur de cuspide et de connecteur de cuspide.

10. Valve cardiaque selon la revendication 1, dans laquelle l'armature de feuillets a un recouvrement en étoffe sensiblement le long de sa longueur entière, le recouvrement en étoffe définissant une bride, où les bords arqués des cuspidés des feuillets flexibles s'attachent à la bride du recouvrement en étoffe.

11. Valve cardiaque selon la revendication 10, dans laquelle la bride du recouvrement en étoffe fait saillie généralement vers l'extérieur de l'armature de feuillets et les bords des cuspidés des feuillets flexibles s'étendent radialement vers l'extérieur au-delà et sous l'armature de feuillets et sont cousus à la bride du recouvrement en étoffe. 5

12. Valve cardiaque selon la revendication 1, dans laquelle chaque feuillet flexible a une paire de pattes s'étendant de chaque côté de son bord libre, où deux pattes de feuillets flexibles adjacents se rejoignent et passent ensemble à l'extérieur de la région de commissure adjacente de l'armature de feuillets et sont attachées à celle-ci par des sutures à travers les pattes. 10 15

20

25

30

35

40

45

50

55



*Fig. 1*

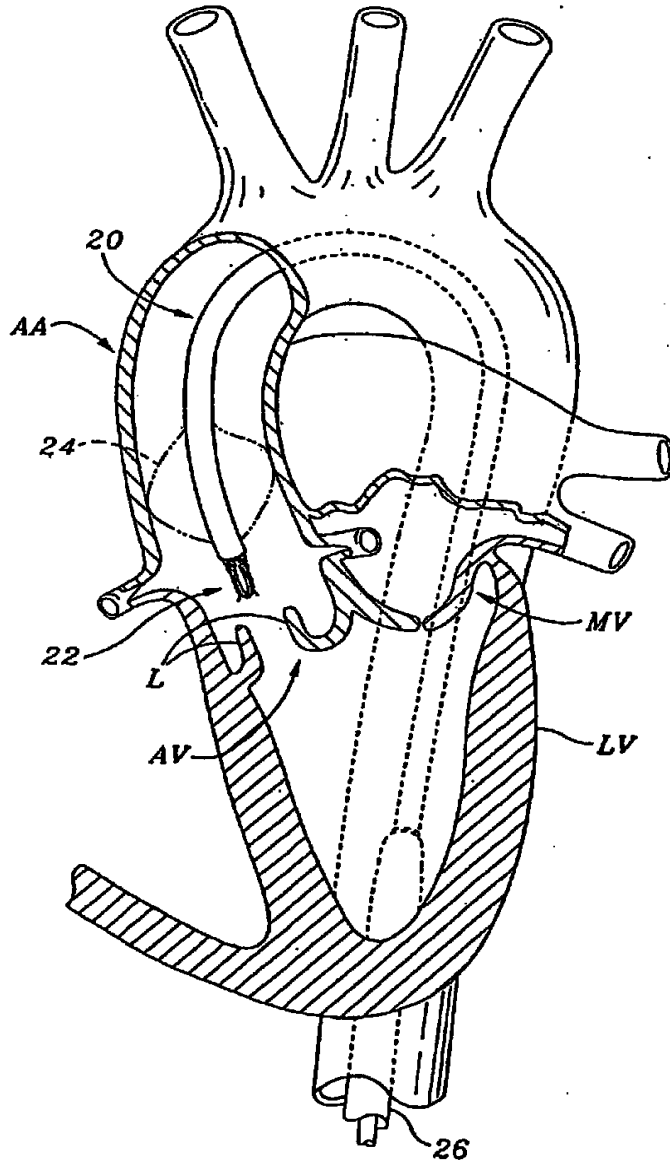


Fig. 2A

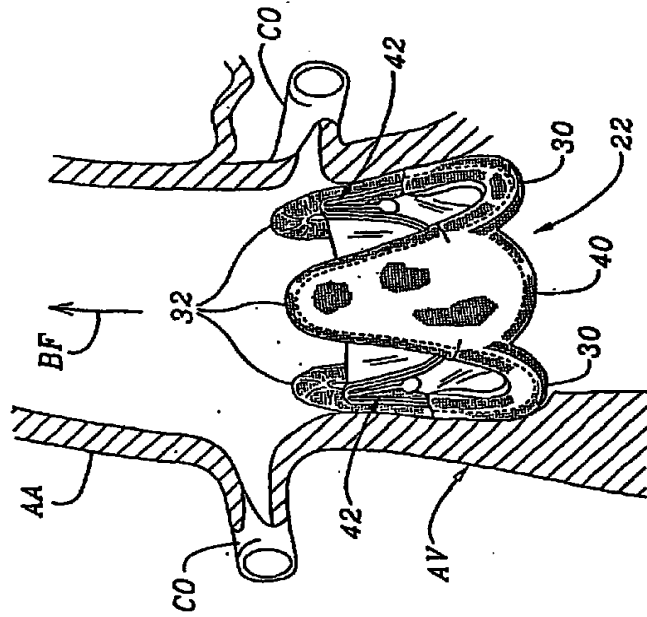
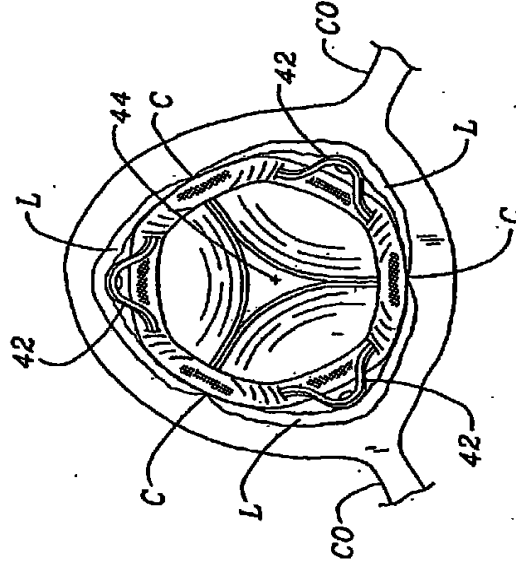


Fig. 2B



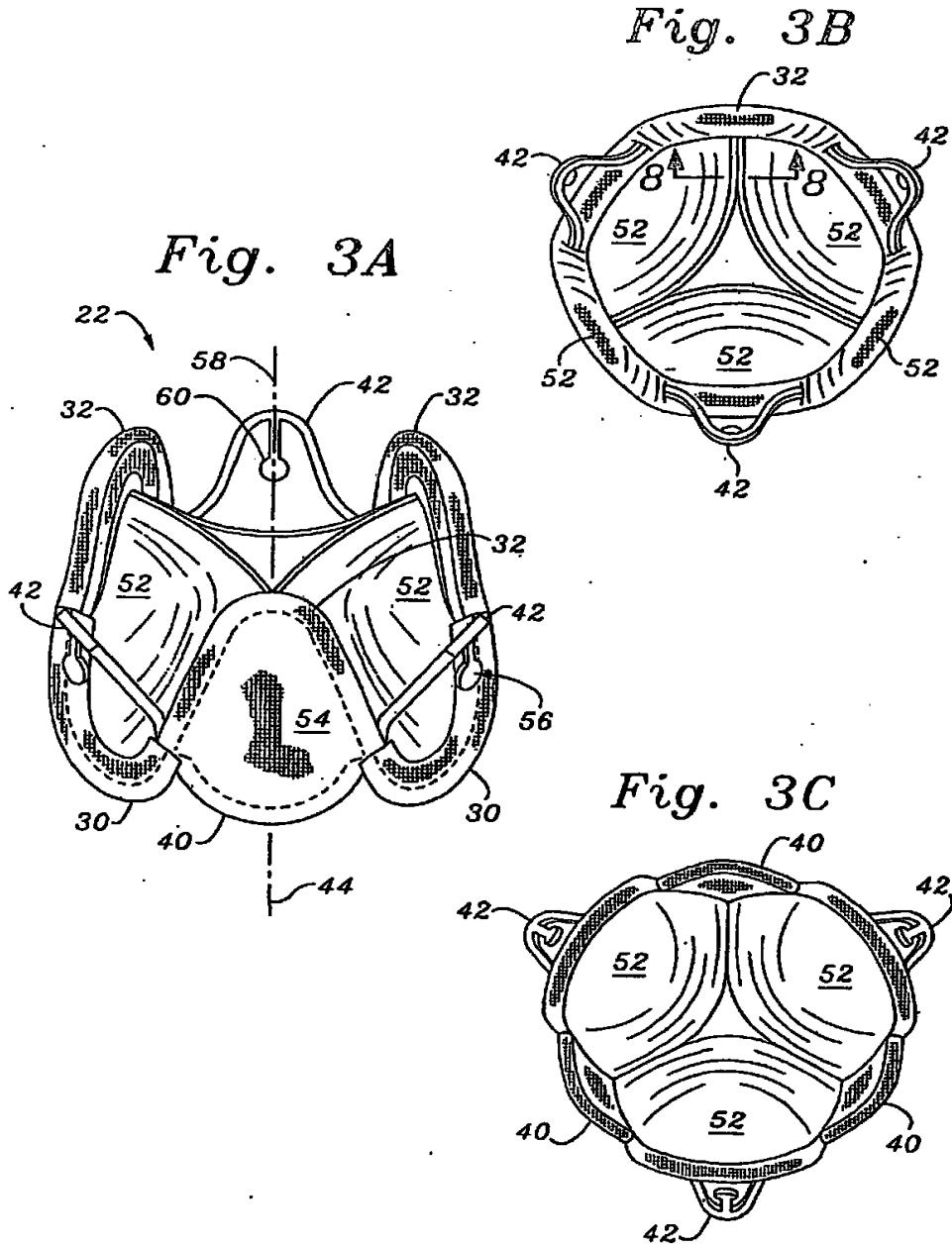


Fig. 4

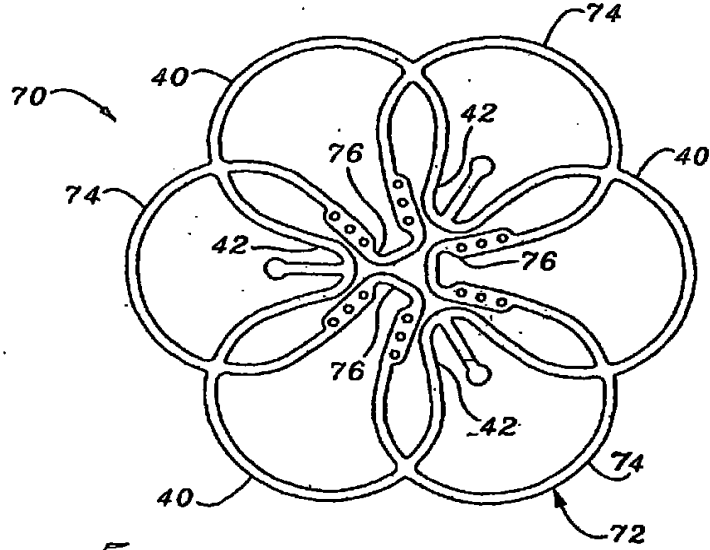


Fig. 5

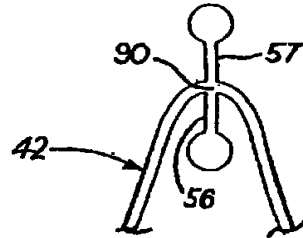
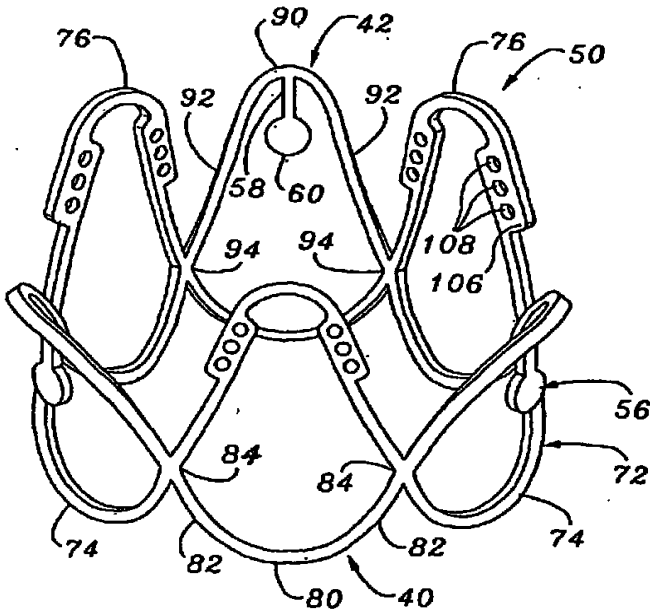


Fig. 5A

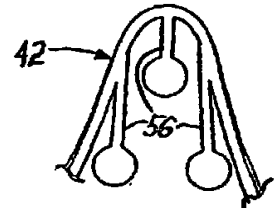
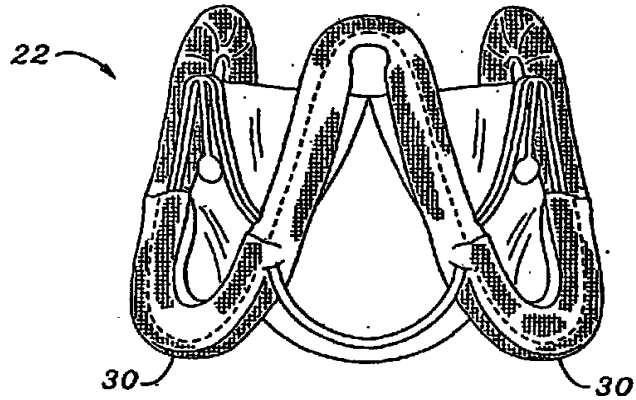


Fig. 5B

*Fig. 6A*



*Fig. 6B*

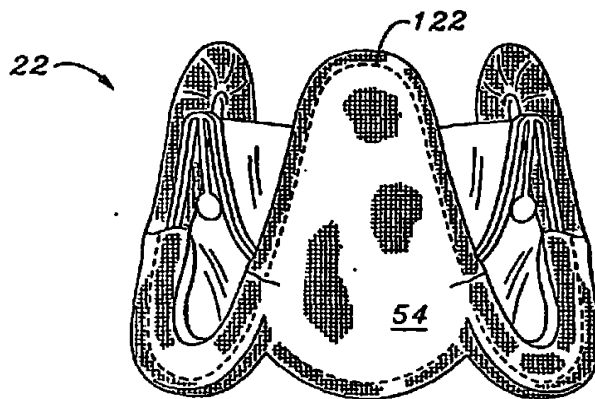


Fig. 7

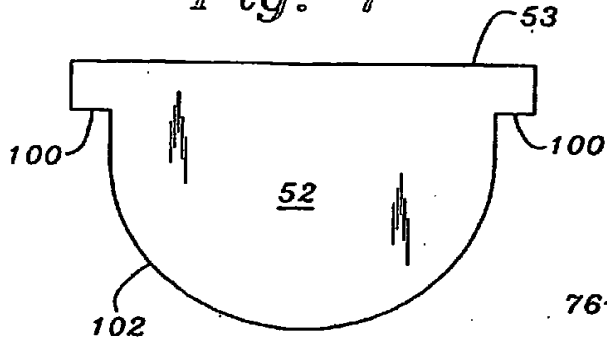


Fig. 8

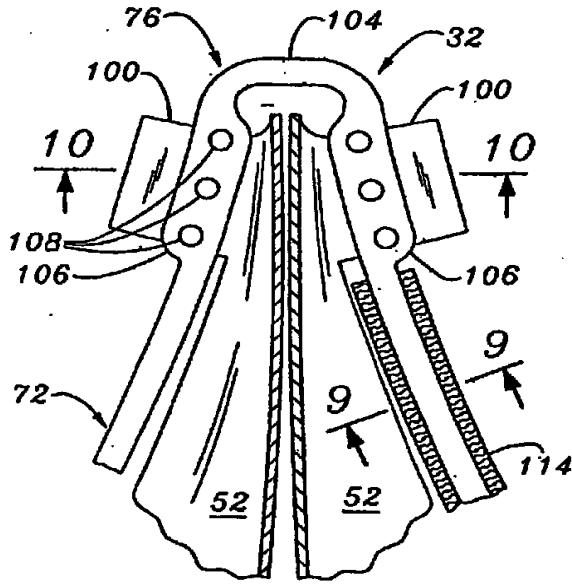


Fig. 9

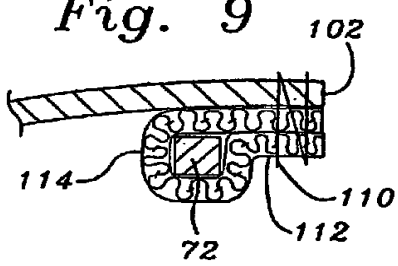
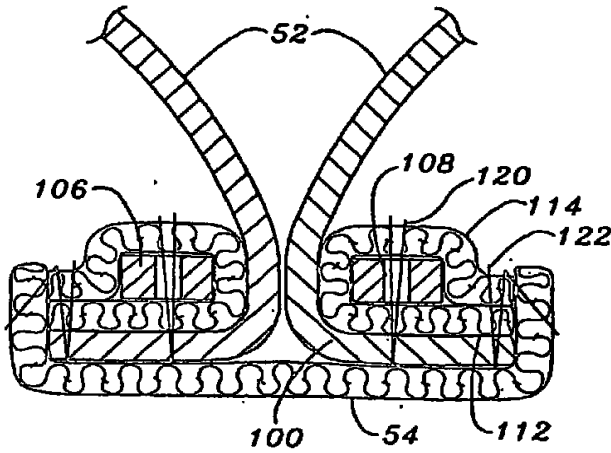


Fig. 10



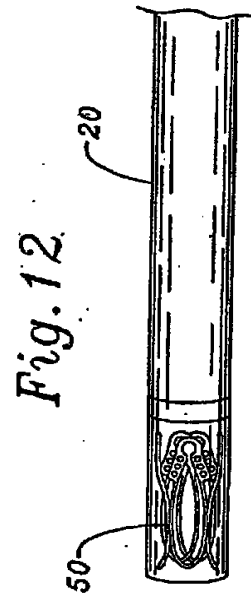
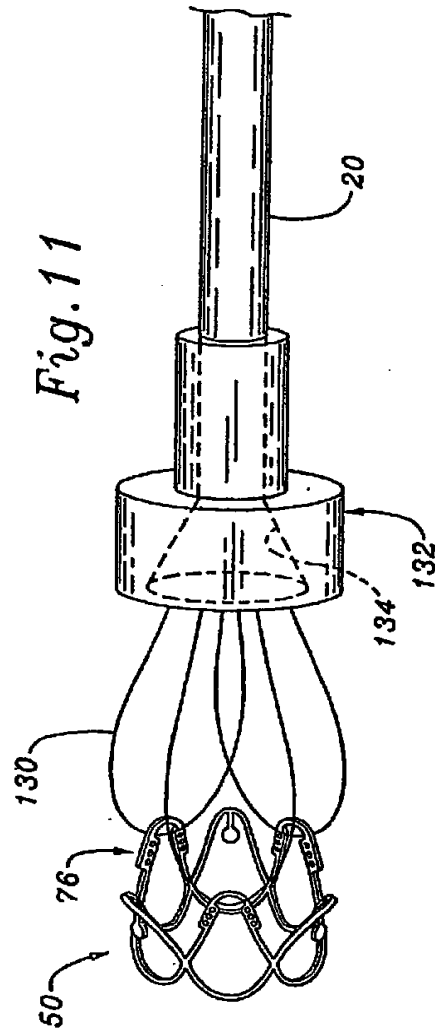


Fig. 13A

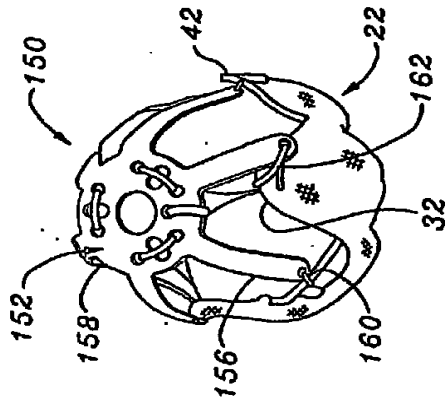


Fig. 14

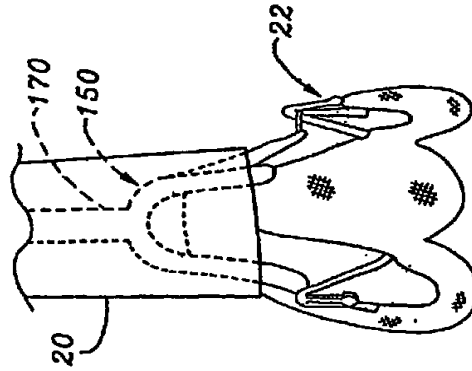
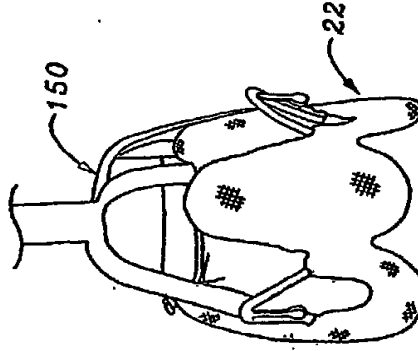
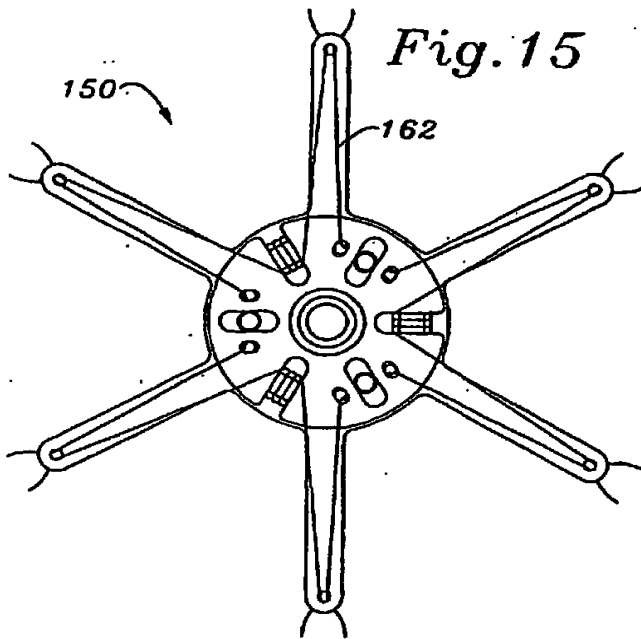
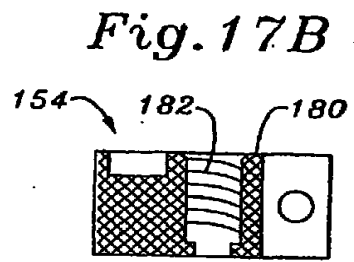
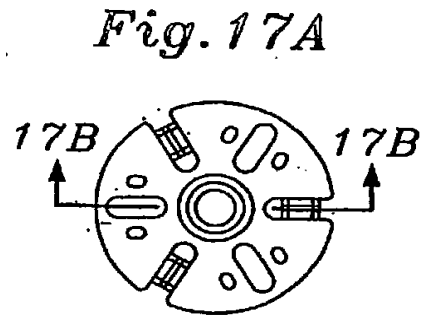
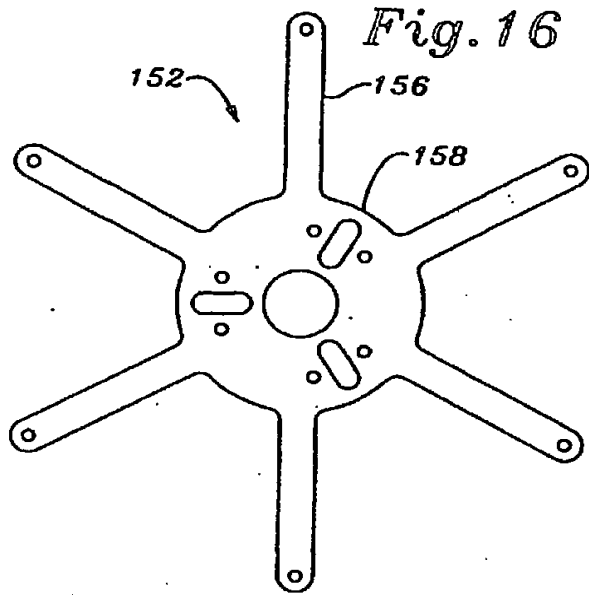


Fig. 13B







**REFERENCES CITED IN THE DESCRIPTION**

*This list of references cited by the applicant is for the reader's convenience only. It does not form part of the European patent document. Even though great care has been taken in compiling the references, errors or omissions cannot be excluded and the EPO disclaims all liability in this regard.*

**Patent documents cited in the description**

- US 6296662 B [0005]
- US 5895420 A [0006]
- US 4056854 A, Boretos [0008]
- US 4994077 A, Dobbins [0008]
- US 5411552 A, Anderson [0010]
- US 5980570 A, Simpson [0010]
- US 5984959 A, Robertson [0010]
- US 6425916 B, Garrison [0010]
- WO 99334142 A, Vesely [0010]
- US 6231602 B [0014]
- US 25165102 A [0051]



(11) **EP 1 621 162 B1**

(12) **EUROPEAN PATENT SPECIFICATION**

(45) Date of publication and mention of the grant of the patent:  
**30.05.2012 Bulletin 2012/22**

(51) Int Cl.:  
**A61F 2/24 (2006.01) B60K 37/06 (2006.01)**

(21) Application number: **05024006.8**

(22) Date of filing: **31.12.1997**

(54) **Valve prosthesis for implantation in body channels**

Klappenprothese zur Implantation in Körpergefäßen

Prothèse de valve pour implantation dans des canaux corporels

(84) Designated Contracting States:  
**DE ES FR GB IT NL**

(73) Proprietor: **Edwards Lifesciences PVT, Inc.**  
**Irvine, CA 92614 (US)**

(30) Priority: **31.12.1996 EP 96402929**

(72) Inventors:

- **Letac, Brice**  
**deceased (FR)**
- **Cribier, Alain**  
**76150 Maromme (FR)**

(43) Date of publication of application:  
**01.02.2006 Bulletin 2006/05**

(74) Representative: **Ramey, Daniel et al**  
**Ernest Gutmann - Yves Plasseraud S.A.S.**  
**3, rue Auber**  
**75009 Paris (FR)**

(60) Divisional application:  
**08016624.2 / 2 000 115**  
**10012626.7 / 2 260 796**  
**10012627.5 / 2 260 797**  
**10012954.3 / 2 263 609**  
**10184036.1 / 2 260 798**

(62) Document number(s) of the earlier application(s) in accordance with Art. 76 EPC:  
**97953935.0 / 0 967 939**

(56) References cited:  
**WO-A-93/01768 WO-A-94/12136**  
**US-A- 3 657 744 US-A- 5 332 402**  
**US-A- 5 411 552**

**EP 1 621 162 B1**

Note: Within nine months of the publication of the mention of the grant of the European patent in the European Patent Bulletin, any person may give notice to the European Patent Office of opposition to that patent, in accordance with the Implementing Regulations. Notice of opposition shall not be deemed to have been filed until the opposition fee has been paid. (Art. 99(1) European Patent Convention).

## Description

**[0001]** The present invention relates to a two-part implantable valve prosthesis for implantation in body channels, more particularly but not only to, cardiac valve prosthesis to be implanted by a transcatheterization technique.

**[0002]** The valve prosthesis can be also applied to other body channels provided with native valves, such as veins or in organs (liver, intestine, urethra,...).

**[0003]** The present description also discloses to a method for implanting a valve prosthesis, such as the valve according to the present invention.

**[0004]** Implantable valves, which will be indifferently designated hereafter as "IV", "valve prosthesis" or "prosthetic valve", permits the reparation of a valvular defect by a less invasive technique in place of the usual surgical valve implantation which, in the case of valvular heart diseases, requires thoracotomy and extracorporeal circulation. A particular use for the IV concerns patients who cannot be operated on because of an associated disease or because of very old age or also patients who could be operated on but only at a very high risk.

**[0005]** Although the IV of the present invention and the process for implanting said IV can be used in various heart valve diseases, the following description will first concern the aortic orifice in aortic stenosis, more particularly in its degenerative form in elderly patients.

**[0006]** Aortic stenosis is a disease of the aortic valve in the left ventricle of the heart. The aortic valvular orifice is normally capable of opening during systole up to 4 to 6 cm<sup>2</sup>, therefore allowing free ejection of the ventricular blood volume into the aorta. This aortic valvular orifice can become tightly stenosed, and therefore the blood cannot anymore be freely ejected from the left ventricle. In fact, only a reduced amount of blood can be ejected by the left ventricle which has to markedly increase the intra-cavitary pressure to force the stenosed aortic orifice. In such aortic diseases, the patients can have syncope, chest pain, and mainly difficulty in breathing. The evolution of such a disease is disastrous when symptoms of cardiac failure appear, since 50 % of the patients die in the year following the first symptoms of the disease.

**[0007]** The only commonly available treatment is the replacement of the stenosed aortic valve by a prosthetic valve via surgery: this treatment moreover providing excellent results. If surgery is impossible to perform, i.e., if the patient is deemed inoperable or operable only at a too high surgical risk, an alternative possibility is to dilate the valve with a balloon catheter to enlarge the aortic orifice. Unfortunately, a good result is obtained only in about half of the cases and there is a high restenosis rate, i.e., about 80% after one year.

**[0008]** Aortic stenosis is a very common disease in people above seventy years old and occurs more and more frequently as the subject gets older. As evidenced, the present tendency of the general evolution of the population is becoming older and older. Also, it can be eval-

uated, as a crude estimation, that about 30 to 50% of the subjects who are older than 80 years and have a tight aortic stenosis, either cannot be operated on for aortic valve replacement with a reasonable surgical risk or even cannot be considered at all for surgery.

**[0009]** It can be estimated that, about 30 to 40 persons out of a million per year, could benefit from an implantable aortic valve positioned by a catheterization technique. Until now, the implantation of a valve prosthesis for the treatment of aortic stenosis is considered unrealistic to perform since it is deemed difficult to superpose another valve such an implantable valve on the distorted stenosed native valve without excising the latter.

**[0010]** From 1985, the technique of aortic valvuloplasty with a balloon catheter has been introduced for the treatment of subjects in whom surgery cannot be performed at all or which could be performed only with a prohibitive surgical risk. Despite the considerable deformation of the stenosed aortic valve, commonly with marked calcification, it is often possible to enlarge significantly the aortic orifice by balloon inflation, a procedure which is considered as low risk.

**[0011]** However, this technique has been abandoned by most physicians because of the very high restenosis rate which occurs in about 80% of the patients within 10 to 12 months. Indeed, immediately after deflation of the balloon, a strong recoil phenomenon often produces a loss of half or even two thirds of the opening area obtained by the inflated balloon. For instance, inflation of a 20 mm diameter balloon in a stenosed aortic orifice of 0.5 cm<sup>2</sup> area gives, when forcefully and fully inflated, an opening area equal to the cross sectionnal area of the maximally inflated balloon, i.e., about 3 cm<sup>2</sup>. However, measurements performed a few minutes after deflation and removal of the balloon have only an area around 1 cm<sup>2</sup> to 1.2 cm<sup>2</sup>. This is due to the considerable recoil of the fibrous tissue of the diseased valve. The drawback in this procedure has also been clearly shown on fresh post mortem specimens.

**[0012]** However, it is important to note that whereas the natural normal aortic valve is able to open with an orifice of about 5 to 6 cm<sup>2</sup> and to accommodate a blood flow of more than 15 l/min. during heavy exercise for instance, an opening area of about 1.5 to 2 cm<sup>2</sup> can accept a 6 to 8 l/min blood flow without a significant pressure gradient. Such a flow corresponds to the cardiac output of the elderly subject with limited physical activity.

**[0013]** Therefore, an IV would not have to produce a large opening of the aortic orifice since an opening about 2 cm<sup>2</sup> would be sufficient in most subjects, in particular in elderly subjects, whose cardiac output probably does not reach more than 6 to 8 l/min. during normal physical activity. For instance, the surgically implanted mechanical valves have an opening area which is far from the natural valve opening that ranges from 2 to 2.5 cm<sup>2</sup>, mainly because of the room taken by the large circular structure supporting the valvular part of the device.

**[0014]** The prior art describes examples of cardiac

valves prosthesis that are aimed at being implanted without surgical intervention by way of catheterization. For instance, US patent n° 5,411,552 describes a collapsible valve able to be introduced in the body in a compressed presentation and expanded in the right position by balloon inflation.

**[0015]** Such valves, with a semi-lunar leaflet design, tend to imitate the natural valve. However, this type of design is inherently fragile, and such structures are not strong enough to be used in the case of aortic stenosis because of the strong recoil that will distort this weak structure and because they would not be able to resist the balloon inflation performed to position the implantable valve. Furthermore, this valvular structure is attached to a metallic frame of thin wires that will not be able to be tightly secured against the valve annulus. The metallic frame of this implantable valve is made of thin wires like in stents, which are implanted in vessels after balloon dilatation. Such a light stent structure is too weak to allow the implantable valve to be forcefully embedded into the aortic annulus. Moreover, there is a high risk of massive regurgitation (during the diastolic phase) through the spaces between the frame wires which is another prohibitive risk that would make this implantable valve impossible to use in clinical practice.

**[0016]** Furthermore, an important point in view of the development of the IV is that it is possible to maximally inflate a balloon placed inside the compressed implantable valve to expand it and insert it in the stenosed aortic valve up to about 20 to 23 mm in diameter. At the time of maximum balloon inflation, the balloon is absolutely stiff and cylindrical without any waist. At that moment, the implantable valve is squeezed and crushed between the strong aortic annulus and the rigid balloon with the risk of causing irreversible damage to the valvular structure of the implantable valve.

#### SUMMARY OF THE INVENTION

**[0017]** The invention is aimed to overcome these drawbacks and to implant an IV which will remain reliable for years.

**[0018]** A particular aim of the present invention is to provide an IV, especially aimed at being used in case of aortic stenosis, which structure is capable of resisting the powerful recoil force and to stand the forceful balloon inflation performed to deploy the IV and to embed it in the aortic annulus.

**[0019]** Another aim of the present invention is to provide an efficient prosthesis valve which can be implanted by a catheterization technique, in particular in a stenosed aortic orifice, taking advantage of the strong structure made of the distorted stenosed valve and of the large opening area produced by preliminary balloon inflation, performed as an initial step of the procedure.

**[0020]** A further aim of the present invention is to provide an implantable valve which would not produce any risk of fluid regurgitation.

**[0021]** A further aim of the present invention is to provide a valve prosthesis implantation technique using a two-balloon catheter and a two-frame device.

**[0022]** These aims are achieved according to the present invention which provides a two-part implantable valve according to claim 1.

**[0023]** The IV, which is strongly embedded, enables the implantable valve to be maintained in the right position without any risk of further displacement, which would be a catastrophic event.

**[0024]** WO 94/12136 discloses stents for body lumens exhibiting peristaltic.

**[0025]** US 5,332,402 discloses a percutaneously-inserted cardiac valve having two components: a tubular structure and an obturator slidable within the tubular structure.

**[0026]** More precisely, this valvular structure comprises a valvular tissue compatible with the human body and blood, which is supple and resistant to allow said valvular structure to pass from a closed state to an open state to allow a body fluid, more particularly the blood, exerting pressure on said valvular structure, to flow. The valvular tissue forms a continuous surface and is provided with guiding means formed or incorporated within, creating stiffened zones which induce the valvular structure to follow a patterned movement from its open position to its closed state and vice-versa, providing therefore a structure sufficiently rigid to prevent diversion, in particular into the left ventricle and thus preventing any regurgitation of blood into the left ventricle in case of aortic implantation.

**[0027]** Moreover, the guided structure of the IV allows the tissue of this structure to open and close with the same patterned movement while occupying as little space as possible in the closed state of the valve. Therefore, owing to these guiding means, the valvular structure withstands the unceasing movements under blood pressure changes during the heart beats.

**[0028]** More preferably, the valvular structure has a substantially truncated hyperboloidal shape in its expanded position, with a larger base and a growing closer neck, ending in a smaller extremity forming the upper part of the valvular structure. The valvular structure has a curvature at its surface that is concave towards the aortic wall. Such a shape produces a strong and efficient structure in view of the systolo-diastolic movement of the valvular tissue. Such a valvular structure with its simple and regular shape also lowers the risk of being damaged by forceful balloon inflation at the time of IV deployment.

**[0029]** A trunco-hyperboloidal shape with a small diameter at the upper extremity facilitates the closure of the valve at the beginning of diastole in initiating the starting of the reverse movement of the valvular tissue towards its base. Another advantage of this truncated hyperboloidal shape is that the upper extremity of the valvular structure, because of its smaller diameter, remains at a distance from the coronary ostia during systole as well as during diastole, thus offering an additional secu-

ity to ensure not to impede at all the passage of blood from the aorta to the coronary ostia.

**[0030]** As another advantageous embodiment, the guiding means of the valvular structure are inclined strips from the base to the upper extremity of the valvular structure with regard to the central axis of the valvular structure. This inclination initiates and imparts a general helicoidal movement of the valvular structure around said central axis at the time of closure or opening of said structure, such a movement enabling to help initiate and finalize the closure of the valvular structure. In particular, this movement improves the collapse of the valvular structure towards its base at the time of diastole and during the reversal of flow at the very beginning of diastole. During diastole, the valvular structure thus falls down, folding on itself and collapses on its base, therefore closing the aortic orifice. The strips can be pleats, strengthening struts or thickened zones.

**[0031]** In other embodiments, said guiding means are rectilinear strips from the base to the upper extremity of the valvular structure. In this case, the guiding means can comprise pleats, struts or thickened zones. In a particular embodiment, the stiffened zones then created can be advantageously two main portions, trapezoidal in shape, formed symmetrically one to each other with regard to the central axis of the valvular structure, and two less rigid portions separating said two main portions to lead to a tight closeness in shape of a closed slot at the time of closure of the upper extremities of the main portions of the valvular structure. The thickened zones can be extended up to form the stiffened zones.

**[0032]** More particularly, each of said main slightly rigid portions occupy approximately one third of the circumference of the valvular structure when this latter is in its open position. The slightly rigid portions maintain the valvular structure closed during diastole by firmly applying themselves on each other. The closure of the valvular structure at the time of diastole thus does not have any tendency to collapse too much towards the aortic annulus.

**[0033]** Preferably, the guiding means are a number of pleats formed within the tissue by folding, or formed by recesses or grooves made in the tissue. The shape of the pleats is adapted to achieve a global shape of the desired type for said position.

**[0034]** Alternatively, the guiding means are made of strengthening struts, preferably at least three, incorporated in the tissue in combination or not with said pleats.

**[0035]** The guiding means and, in particular, the strengthening struts, help to prevent the valvular tissue from collapsing back too much and to reverse inside the left ventricle through the base of the frame, preventing the risk of blood regurgitation.

**[0036]** In a preferred prosthetic valve of the invention, said valvular tissue is made of synthetic biocompatible material such as Teflon® or Dacron®, polyethylene, polyamide, or made of biological material such as pericardium, porcine leaflets and the like. These materials

are commonly used in cardiac surgery and are quite resistant, particularly to folding movements due to the increasing systolo-diastolic movements of the valvular tissue and particularly at the junction with the frame of the implantable valve.

**[0037]** The valvular structure is fastened along a substantial portion of an expandable frame, by sewing, by molding or by gluing to exhibit a tightness sufficiently hermetic to prevent any regurgitation of said body fluid between the frame and the valvular structure.

**[0038]** Preferably, an internal cover is coupled or is integral to the valvular structure and placed between said valvular structure and the internal wall of the frame to prevent any passage of the body fluid through said frame.

Therefore, there is no regurgitation of blood as it would be the case if there were any space between the valvular structure fastened on the frame and the zone of application of the frame on the aortic annulus. The internal cover makes a sort of "sleeve" at least below the fastening of the valvular structure covering the internal surface of the frame and thus prevents any regurgitation of blood through the frame.

**[0039]** In the present invention, the frame is a substantially cylindrical structure capable of maintaining said body channel open in its expanded state and supporting said collapsible valvular structure.

**[0040]** In a preferred embodiment of the invention, the frame is made of a material which is distinguishable from biological tissue to be easily visible by non invasive imaging techniques.

**[0041]** Preferably, said frame is a stainless metal structure or a foldable plastic material, made of intercrossing, preferably with rounded and smooth linear bars. This frame is strong enough to resist the recoil phenomenon of the fibrous tissue of the diseased valve. The size of the bars and their number are determined to give both the maximal rigidity when said frame is expanded and the smallest volume when the frame is compressed.

**[0042]** More preferably, the frame has projecting curved extremities and presents a concave shape. This is aimed at reinforcing the embedding and the locking of the implantable valve in the distorted aortic orifice.

**[0043]** According to the present invention, the IV is made in two parts, a first reinforced frame coupled with a second frame which is made of thinner bars than said first frame and which is embedded inside the second frame. This second frame to which the valvular structure is fastened as described above, is preferably less bulky than the first frame to occupy as little space as possible and to be easily expanded using low pressure balloon inflation.

**[0044]** The present invention also relates to a double balloon catheter to separately position the first frame in the dilated stenosed aortic valve and place the second frame that comprises the valvular structure. This catheter comprises two balloons fixed on a catheter shaft and separated by few centimeters.

**[0045]** The first balloon is of the type sufficiently strong

to avoid bursting even at a very high pressure inflation and is aimed at carrying, in its deflated state, a strong frame aimed at scaffolding the previously dilated stenosed aortic valve. The second balloon is aimed at carrying the second frame with the valvular structure.

**[0046]** An advantage of this double balloon catheter is that each balloon has an external diameter which is smaller than known balloons since each element to be expanded is smaller.

**[0047]** Moreover, such a double balloon catheter allows to enlarge the choice for making an efficient valvular structure enabling to overcome the following two contradictory conditions:

- 1) having a soft and mobile valvular structure capable of opening and closing freely in the blood stream, without risk of being damaged by balloon inflation; and
- 2) needing a very strong structure able to resist the recoil force of the stenosed valve and capable of resisting, without any damage, a strong pressure inflation of the expanding balloon.

**[0048]** Furthermore, the shaft of said double balloon catheter comprises two lumens for successive and separate inflation of each balloon. Of note, an additional lumen capable of allowing a rapid inflation takes additional room in the shaft.

**[0049]** The description also discloses a method of using a two-balloon catheter with a first frame and second frame to which a valve prosthesis of the type previously described is fastened.

#### DESCRIPTION OF THE DRAWINGS

**[0050]** The invention will now be explained and other advantages and features will appear with reference to the accompanying schematical drawings wherein :

- Figures 1a, 1b and 1c illustrate, in section views, respectively, the normal aortic valve in systole, in diastole and a stenosed aortic valve;
- Figures 2a and 2b illustrate two examples of a metallic frame which are combined to a valvular structure according to the present invention;
- Figures 3a and 3b illustrate a frame in its expanded position with an opening out of the extremities, respectively, with a cylindrical and a concave shape;
- Figures 4a and b illustrate an IV respectively in its compressed position and in its expanded position in an open position as in systole;
- Figures 5a and 5b illustrate respectively an IV in its closed position and a sectional view according to the central axis of such a valvular structure which is closed as in diastole;
- Figures 6a to 6d illustrate a sectional view according to the central axis of an IV and showing the internal cover and the external cover of the valvular structure

overlapping partially or non overlapping the frame bars;

- Figure 7 illustrates the frontal zig-zag fastening line of the valvular tissue on the frame;
- 5 - Figures 8a and 8b illustrate, respectively, a perspective view of a valvular structure and an internal cover made all of one piece and a perspective view of the corresponding frame into which they will be inserted and fastened;
- 10 - Figures 9a and 9b illustrate inclined strengthening struts, an example of a valvular structure, respectively in the open position and in the closed position;
- Figures 10a and 10b illustrate an example of a valvular structure comprising pleats, respectively in the open and in the closed position;
- 15 - Figures 11a and 11b illustrate a valvular structure comprising two trapezoidal slightly rigid portions, respectively in the open and in the closed position;
- Figures 11c to 11e illustrate a valvular structure comprising a rectangular stiffened zone, respectively in the open, intermediate and closed position;
- 20 - Figures 12a and 12b illustrate, respectively, a perspective and cross sectional views of an implantable valve in its compressed presentation squeezed on a balloon catheter;
- 25 - Figures 13a to 13l illustrate views of the successive procedure steps for the IV implantation in a stenosed aortic orifice;
- Figure 14 illustrate an implantable valve made in two parts according to the present invention in its compressed presentation squeezed on a two-balloon catheter with a reinforced frame on a first balloon and with the implantable valve on the second balloon; and
- 30 - Figures 15a to 15f illustrate the successive steps of the implantation of the implantation valve in two parts with a two-balloon catheter;
- 35

#### DETAILED DESCRIPTION OF THE PREFERRED EMBODIMENTS

**[0051]** In the diastole and systole illustrations of section views of Figures 1a and 1b, the arrows A indicates the general direction of the blood flow. The semi-lunar leaflets 1 and 2 of a native aortic valve (with only two out of three shown here) are thin, supple and move easily from the completely open position (systole) to the closed position (diastole). The leaflets originate from an aortic annulus 2a.

50 **[0052]** The leaflets 1' and 2' of a stenosed valve as illustrated in Figure 1c, are thickened, distorted, calcified and more or less fused, leaving only a small hole or a narrow slit 3, which makes the ejection of blood from the left ventricle cavity 4 into the aorta 5 difficult and limited.

55 Figures 1a to 1c show also the coronary artery ostium 6a and 6b and Figure 1a shows, in particular, the mitral valve 7 of the left ventricle cavity 4.

**[0053]** An implantable valve according to the invention

essentially comprises a supple valvular structure supported by a strong frame. The positioning of the implantable valve is an important point since the expanded frame has to be positioned exactly at the level of the native valvular leaflets 1, 2 of the native valve, the structures of which are pushed aside by the inflated balloon.

**[0054]** Ideally, the implantable valve is positioned with the fastening line of the valvular structure on the frame exactly on the remains of the crushed stenosed valve to prevent any regurgitation of blood. In practice, it is difficult to position the implantable valve within less than 2 or 3 mm. However, any risk of regurgitation of blood is eliminated with the presence of an internal cover, as will be described below.

**[0055]** The upper limit of the frame should be placed below the opening of the coronary arteries, i.e., the coronary ostia 6, or at their level so that the frame does not impede free blood flow in the coronary arteries. This point is a delicate part of positioning an IV since the distance between the superior limit of the leaflets of the natural valve and the coronary ostia 6 is only about 5 to 6 mm. However, the ostia are located in the Valsalva sinus 8 which constitutes a hollow that are located a little out of the way. This helps to prevent from impeding the coronary blood flow by the IV.

**[0056]** At the time of implantation, the operator evaluates the exact positioning of the coronary ostia by looking at the image produced by a sus-valvular angiogram with contrast injection performed before the implantation procedure. This image will be fixed in the same projection on a satellite TV screen and will permit the evaluation of the level of the origin of the right and left coronary arteries. Possibly, in case the ostia are not clearly seen by sus-valvular angiography, a thin guide wire, as those used in coronary angioplasty, is positioned in each of the coronary arteries to serve as a marker of the coronary ostia.

**[0057]** The lower part of the frame of the IV preferably extends by 2 or 3 mm inside the left ventricle 4, below the aortic annulus 2a. However, this part of the frame should not reach the insertion of the septal leaflet of the mitral valve 7, so that it does not interfere with its movements, particularly during diastole.

**[0058]** Figures 2a and 2b show respectively an example of a cylindrical frame 10 comprising intercrossing linear bars 11, with two intersections I by bar 11, the bars 11 being soldered or provided from a folded wire to constitute the frame, with for instance a 20 mm, 15 mm or 12 mm height, and an example with only one intersection of bars 11. Preferably, such a frame is expandable from a size of about 4 to 5 millimeters to a size of about 20 to 25 mm in diameter, or even to about 30-35 mm (or more) in particular cases, for instance for the mitral valve. Moreover, said frame, in its fully expanded state, has a height of approximately between 10 and 15 mm and in its fully compressed frame, a height of approximately 20 mm. The number and the size of the bars are adapted to be sufficiently strong and rigid when the frame is fully open in the aortic orifice to resist the strong recoil force exerted

by the distorted stenosed aortic orifice after deflation of the balloon used in the catheterization technique which has been previously maximally inflated to enlarge the stenosed valve orifice;

**[0059]** The frame may have several configurations according to the number of bars 11 and intersections. This number, as well as the size and the strength of the bars 11, are calculated taking into account all the requirements described, i.e., a small size in its compressed form, its capacity to be enlarged up to at least 20 mm in diameter and being strong when positioned in the aortic orifice to be able to be forcefully embedded in the remains of the diseased aortic valve and to resist the recoil force of the aortic annulus. The diameter of the bars is chosen, for instance, in the range of 0.1-0.6 mm.

**[0060]** A frame particularly advantageous presents, when deployed in its expanded state, an opening out 12 at both extremities as shown in Figures 3a and 3b, the frame having a linear profile (Figure 3a) or a concave shape profile (Figure 3b). This is aimed at reinforcing the embedding of the IV in the aortic orifice. However, the free extremities of the openings 12 are rounded and very smooth to avoid any traumatism of the aorta or of the myocardium.

**[0061]** The structure of a preferred frame used in the present invention both maintains the aortic orifice fully open once dilated and produces a support for the valvular structure. The frame is also foldable. When folded by compression, the diameter of said frame is about 4 to 5 millimeters, in view of its transcatheter introduction in the femoral artery through an arterial sheath of 14 to 16 F (F means French, a unit usually used in cardiology field) i.e., about 4.5 to 5.1 mm. Also, as described below, when positioned in the aortic orifice, the frame is able to expand under the force of an inflated balloon up to a size of 20 to 23 mm in diameter.

**[0062]** The frame is preferably a metallic frame, preferably made of steel. It constitutes a frame with a grate type design able to support the valvular structure and to behave as a strong scaffold for the open stenosed aortic orifice.

**[0063]** When the frame is fully expanded, its intercrossing bars push against the remains of the native stenosed valve that has been crushed aside against the aortic annulus by the inflated balloon. This produces a penetration and embeds the bars within the remains of the stenosed valve, in particular owing to a concave profile of the frame provided with an opening out, as illustrated in Figure 3b. This embedding of the frame on the aortic annulus, or more precisely on the remains of the crushed distorted aortic valve, will be determinant for the strong fixation of the IV in the right position, without any risk of displacement.

**[0064]** Moreover, the fact that the valve leaflets in degenerative aortic stenosis are grossly distorted and calcified, sometimes leaving only a small hole or a small slit in the middle of the orifice, has to be considered an advantage for the implantation of the valve and for its stable



positioning without risk of later mobilization. The fibrous and calcified structure of the distorted valve provides a strong base for the frame of the IV and the powerful recoil phenomenon that results from elasticity of the tissues contribute to the fixation of the metallic frame.

**[0065]** The height of the fully expanded frame of the illustrated frames 10 is preferably between 10 and 15 mm. Indeed, since the passage from the compressed state to the expanded state results in a shortening of the metallic structure, the structure in its compressed form is a little longer, i.e., preferably about 20 mm length. This does not constitute a drawback for its transcutaneous introduction and its positioning in the aortic orifice.

**[0066]** As mentioned above, the frame is strong enough to be able to oppose the powerful recoil force of the distended valve and of the aortic annulus 2a. Preferably it does not possess any flexible properties. When the frame has reached its maximal expanded shape under the push of a forcefully inflated balloon, it remains substantially without any decrease in size and without any change of shape. The size of the bars that are the basic elements of the frame is calculated in such a way to provide a substantial rigidity when the frame is fully expanded. The size of the bars and their number are calculated to give both maximal rigidity when expanded and the smallest volume when the metallic frame is its compressed position.

**[0067]** At the time of making the IV, the frame is expanded by dilatation to its broadest dimension, i.e., between 20 mm and 25 mm in diameter, so as to be able to fasten the valvular structure on the inside side of its surface. This fastening is performed using the techniques in current use for the making of products such as other prosthetic heart valves or multipolar catheters etc. Afterwards, it is compressed in its minimal size, i.e., 4 or 5 mm, in diameter in view of its introduction in the femoral artery. At time of the IV positioning, the frame is expanded again by balloon inflation to its maximal size in the aortic orifice.

**[0068]** If the frame is built in an expanded position, it will be compressed, after fastening the valvular structure, by exerting a circular force on its periphery and/or on its total height until obtaining the smallest compressed position. If the frame is built in its compressed position, it will be first - dilated, for instance, by inflation of a balloon and then compressed again as described above.

**[0069]** To help localizing the IV, the frame being the only visible component of the valve, the shaft of the balloon catheter on which will be mounted the IV before introduction in the body (see below) possesses preferentially metallic reference marks easily seen on fluoroscopy. One mark will be at level of the upper border of the frame and the other at the level of the lower border. The IV, when mounted on the catheter shaft and crimped on it, is exactly positioned taking into account these reference marks on the shaft.

**[0070]** Accordingly, the frame is visible during fluoroscopy when introduced in the patient's body. When the

frame is positioned at the level of the aortic annulus, the upper border of the frame is placed below the coronary ostia. Furthermore, the implanting process during which the balloon inflation completely obstructs the aortic orifice, as seen below, is performed within a very short time, i.e., around 10 to 15 seconds. This also explains why the frame is clearly and easily seen, without spending time to localize it. More particularly, its upper and lower borders are clearly delineated.

**[0071]** Figures 4a and 4b show an example of a IV 13 respectively in its compressed position, in view of its introduction and positioning in the aortic orifice, and in its expanded and opened (systole) position. Figures 5a and 5b show the expanded position of this example closed in diastole, respectively in perspective and in a crossed section view along the central axis X'X of the valve prosthesis.

**[0072]** The valvular structure 14 is compressed inside the frame 10 when this is in its compressed position (Figure 4a), i.e., it fits into a 4 to 5 mm diameter space. On the other hand, the valvular structure can expand (Figure 4b) and follow the frame expansion produced by the inflated balloon. It will have to be able to reach the size of the inside of the fully deployed frame.

**[0073]** The illustrated IV 13 is made of a combination of two main parts:

- 1) the expandible but substantially rigid structure made of the frame 10, a metallic frame in the example; and
- 2) a soft and mobile tissue constituting the valvular structure 14 exhibiting a continuous surface truncated between a base 15 and an upper extremity 16; the tissue is fastened to the bars 11 of the frame at its base 15 and is able to open in systole and to close in diastole at its extremity 16, as the blood flows in a pulsatile way from the left ventricle towards the aorta.

**[0074]** The tissue has rectilinear struts 17 incorporated in it in plane including the central axis X'X, in order to strengthen it, in particular, in its closed state with a minimal occupation of the space, and to induce a patterned movement between its open and closed state. Other examples of strengthening struts are described below. They are formed from thicker zones of the tissue or from strips of stiffening material incorporated in the tissue; they can also be glued or soldered on the valvular tissue.

**[0075]** These strengthening struts help to prevent the valvular tissue from collapsing back too much and to evert inside the left ventricle through the base of the frame. These reinforcements of the valvular tissue help maintain the folded tissue above the level of the orifice during diastole, prevent too much folding back and risk of inversion of the valvular structure inside the left ventricle. By also preventing too much folding, a decrease of the risk of thrombi formation can also be expected by reducing the number of folds.

**[0076]** The truncated shape forming a continuous surface enables to obtain a strong structure and is more efficient for the systolo-diastolic movements of the valvular tissue during heart beats. The truncoïdal shape facilitates the closure of the valve structure at the beginning of diastole in facilitating the start of the reverse movement of the valvular tissue towards its base at the time of diastole, i.e., at the time of flow reversal at the very beginning of diastole. During diastole, the valvular structure 14 thus falls down, folding on itself, thereby collapsing on its base, and therefore closing the aortic orifice. In fact, the valvular structure has preferably, as illustrated, an hyperboloid shape, with a curvature on its surface concave towards the aortic wall that will contribute to initiating its closure.

**[0077]** Moreover, the basis of the truncated hyperboloid is fixed on the lower part of a frame and the smallest extremity of the truncated hyperboloid is free in the blood stream, during the respected closing and opening phasis.

**[0078]** An important advantage of this hyperboloidal shape is that the upper extremity 16 of the valvular structure 14 can remain at a distance from the coronary ostia during systole as well as during diastole, because of its smaller diameter, thus offering an additional security to make certain that the passage of blood from aorta to the coronary ostia is not impeded.

**[0079]** The base 15 of the truncated tissue is attached on the frame 10 along a line of coupling 18 disposed between the inferior fourth and the third fourth of the frame in the example. The upper extremity 16, with the smaller diameter, overpasses the upper part of the frame by a few millimeters; 6 to 8 mm, for instance. This gives the valvular structure a total height of about 12 to 15 mm.

**[0080]** The upper extremity 16 of the truncated tissue, i.e., the smaller diameter of the hyperboloidal structure 14, is about 17 to 18 mm in diameter (producing a 2.3 to 2.5 cm<sup>2</sup> area opening) for a 20 mm diameter base of the truncated structure, or 19 to 20 mm in diameter (producing a 2.8 or a 3 cm<sup>2</sup> area opening) for a 23 mm diameter base. An opening area around 2 cm<sup>2</sup> or slightly above, gives satisfactory results, particularly in elderly patients who would not reasonably need to exert high cardiac output.

**[0081]** For instance, in the present example, the line of fastening of the base of the truncated tissue on the frame will have to expand from a 12.5 mm perimeter (for a 4 mm external diameter of the compressed IV) to a 63 mm perimeter (for a 20 mm external diameter of the expanded IV), or to a 72 mm perimeter (for a 23 mm external diameter, in case a 23 mm balloon is used).

**[0082]** Another advantage of this truncated continuous shape is that it is stronger and has less risk of being destroyed or distorted by the forceful balloon inflation at the time of IV deployment. Also, if the truncated hyperboloidal shape is marked, for instance, with a 16 or 17 mm diameter of the upper extremity as compared to a 20 mm diameter of the base (or 18 to 20 mm for 23 mm), the smaller upper part is compliant during balloon infla-

tion in order to enable the balloon to expand cylindrically to its maximal 20 mm diameter (or 23 mm). This is made possible by using a material with some elastic or compliant properties.

**[0083]** The valvular structure of the invention, as shown in the illustrated example, includes advantageously a third part, i.e., the internal cover 19 to be fixed on the internal wall of the frame 10. This internal cover prevents any passage of blood through the spaces between the bars 11 of the frame in case the implantable valve would be positioned with the fastening line of the valvular structure on the frame not exactly on the remains of the dilated aortic valve, i.e., either above or below. It also strengthens the fastening of the valvular structure 14 to the frame 10.

**[0084]** In the different sectional views of the different examples of IV according to the invention, as illustrated at Figures 6a to 6c, the internal cover 19 covers the totality of the internal side of the frame 10 (Figure 6a), only the lower part of the frame 10 (figure 6b), or it can additionally cover partially 3 to 5 mm as shown in the passage of blood from aorta to the coronary ostia Figure 6c, the upper part defined above the coupling line 18 of the valvular structure.

**[0085]** For instance, such an extension of the internal cover 19 above the fastening line 18 of the valvular structure will give another security to avoid any risk of regurgitation through the spaces between the bars 11 in case the IV would be positioned too low with respect to the border of the native aortic valve.

**[0086]** The internal cover can also be molded to the valvular structure or casted to it which therefore constitutes an integral structure. The valvular structure and the internal cover are therefore strongly locked together with minimum risk of detachment of the valvular structure which is unceasingly in motion during systole and diastole. In that case, only the internal cover has to be fastened on the internal surface of the frame which renders the making of the IV easier and makes the complete device stronger and more resistant. In particular, the junction of the mobile part of the valvular structure and the fixed part being molded as one piece is stronger and capable to face the increasing movements during the systolo-diastolic displacements without any risk of detachment.

**[0087]** The presence of the internal cover makes an additional layer of plastic material that occupies the inside of the frame and increases the final size of the IV. Therefore, in the case in which the internal cover is limited to the inferior part of the frame (that is, below the fastening line of the valvular structure), it does not occupy any additional space inside the frame. Here also, it is more convenient and safer to make the valvular structure and this limited internal cover in one piece.

**[0088]** In other aspects, to prevent any regurgitation of blood from the aorta towards the left ventricle during diastole, the base of the valvular structure is preferably positioned exactly at the level of the aortic annulus

against the remains of distorted stenosed valve pushed apart by the inflated balloon. Therefore, there is no possibility of blood passage through the spaces between the metallic frame bars 11 below the attachment of the valvular structure.

**[0089]** However, to avoid any risk of leaks, the part of the frame below the fastening of the valvular structure (about 3 to 5 mm) is preferably covered by an internal cover which is preferably made with the same tissue as the valvular structure. Thus, there would be no regurgitation of blood which is a possibility when there is any space between the valvular structure fastened on the metallic frame and the line of application of the frame on the aortic annulus. The internal cover makes a sort of "sleeve" below the fastening of the valvular structure on the internal surface of the frame, covering the spaces between the frame bars of the frame at this level, thus preventing any regurgitation of blood through these spaces.

**[0090]** The internal cover can also have another function, i.e., it can be used to fasten the valvular structure inside the frame, as described below.

**[0091]** At Figure 6d, the internal cover 19 is extended at its lower end 19' to an external cover 19" which is rolled up to be applied on the external wall of the stent 10. The internal and external cover are molded, glued or soldered to the bars of the stent 10.

**[0092]** The coupling process of the valvular structure on the frame is of importance since it has to be very strong without any risk of detachment of the valvular structure from the frame during millions of heart beats with pulsatile blood flow alternatively opening and closing the valvular structure.

**[0093]** The valvular structure of the invention folds to a very small size inside the frame in the compressed position of the valve and is expandable up to 20 to 23 mm diameter. Also, the valvular structure can resist the strong force exerted by the maximally inflated balloon that will powerfully squeeze it against the bars of the frame or against the internal cover, this one being squeezed directly against the bars of the frame. The junction zone is also particularly subjected to very strong pressure exerted by the inflated balloon. Furthermore, this junction zone must not tear or break off during expansion of the balloon. At this time, each part of the junction zone is squeezed against the bars but nonetheless follows the expansion of the frame.

**[0094]** As shown in Figure 7, the junction zone is, for example, a fastening line 20 which follows the design of a "zig-zag" line drawn by the intercrossing bars 11 of the frame on the internal cover 19.

**[0095]** The fastening of the valvular structure to the frame can be made by sewing the internal and/or the external cover to the bars. To prevent any leakage of blood, stitches are preferably numerous and very close to each other, either as separated stitches or as a continuous suture line. Also, the stitches are made directly around the bars 11. Furthermore, since the valvular struc-

ture is expanded together with the metallic frame, the stitches, if made as a continuous suture line, are also able to expand at the same time.

**[0096]** The fastening process can also be made by molding the base of the valvular structure on the frame. At this level, the bars 11 are imbedded in the coupling line of the valvular structure 14. This mold way also concerns the internal cover 19, when it goes below the coupling line 14 on the frame over few millimeters, for example, 2 to 4 mm. As mentioned above, this is intended in order to prevent any regurgitation of blood just below the lower part of the valvular structure 14 in case the frame 10 would not be exactly positioned on the aortic annulus but at few millimeters away.

**[0097]** The fastening process can further be made by gluing or soldering the valvular structure on the bars with sufficiently powerful biocompatible glues. The same remark can be made concerning the internal cover of the frame below the coupling line of the valvular structure.

**[0098]** Also, this allows the coupling line to follow the frame changes from the compressed position to its expanded one.

**[0099]** The valvular structure can also be fastened on the internal cover previously fixed at the total length of the internal surface of the metallic frame. The internal cover constitutes therefore a surface on which any type of valvular structure be more easily sewed, molded or glued. Because it is a structure with a large surface and is not involved in the movements of the valvular tissue during systole and diastole, the internal cover is more easily fastened to the internal surface of the frame.

**[0100]** In the particular embodiment shown in Figure 8, the internal cover 19 is fastened, after introduction (indicated by the arrow B), at the upper and lower extremities of the frame 10 on the upper and lower zig-zag lines of the intercrossing bars 11. In fact, the fastening of the internal cover 19 on the zig-zag lines made by the intercrossing bars 11 of the frame allows an easier passage of blood from the aorta above the IV towards the coronary ostia. Indeed, the blood can find more space to flow into the coronary ostia by passing through the lowest point of each triangular space made by two intercrossing bars 11, as indicated by the arrows A1 (see also Figure 1b).

**[0101]** The fastening of the internal cover 19 on the extremities can be reinforced by various points of attachment on various parts of the internal surface of the frame 10. The internal cover 27 can be fastened by sewing, molding or gluing the bars 11 onto the frame.

**[0102]** Fastening the valvular tissue (and the cover tissue below) on the inside of the frame, requires work on the frame in its expanded position to have access to the inside of this cylindric frame. In a preferred embodiment the frame is expanded a first time for fastening the valvular tissue on its bars, then compressed back to a smaller size to be able to be introduced via arterial introducer and finally expanded again by the balloon inflation.

**[0103]** Since it is aimed at being positioned in the heart after having been introduced by a catheterization tech-

nique by a transcatheter route in a peripheral artery, mainly the femoral artery, the IV should preferably have the smallest possible external diameter. Ideally, it should be able to be introduced in the femoral artery through a 14 F (4,5 mm) size arterial introducer which is the size of the arterial introducer commonly used to perform an aortic dilatation. However, a 16 F (5,1 mm) or even a 18 F (5,7 mm) introducer would also be acceptable.

**[0104]** Above this size, the introduction of the IV in the femoral artery should probably be done by a surgical technique. This is still quite acceptable since the surgical procedure would be a very light procedure which could be done by a surgeon with a simple local anaesthesia. It has to be recalled that this technique is used to position big metallic frames, about 24 F in size (7.64 mm in diameter), in the abdominal aorta for the treatment of aneurysms of the abdominal aorta. In that situation, this necessitates surgical repair of the artery after withdrawal of the sheath (M. D. Dake, New Engl. J Med. 1994;331: 1729-34).

**[0105]** Ideally, an IV should be able to last several tenths of life years without defect, like the mechanical prosthetic valves which are currently implanted by the surgeons. Nevertheless, an implantable valve that would last at least ten years without risk of deterioration would be effective for the treatment of elderly patients.

**[0106]** A valvular structure according to the invention is made of a supple and reinforced tissue which has a thickness to be thin enough to occupy as less as possible space in the compressed form of the valve, is pliable, and also strong enough to stand the unceasing movements under the blood pressure changes during heart beats. The valvular structure is capable of moving from its closed position to its open position under the action of the force exerted by the movements of the blood during systole and diastole, without having any significant resistance to blood displacements.

**[0107]** The material used for the tissue, which exhibits the above mentioned requirements, may be Teflon® or Dacron®, which are quite resistant to folding movements, at least when they are used to repair cardiac defects such as inter-atrial or interventricular defects or when they are used to repair a valve such as the mitral valve which is subjected to high pressure changes and movements during heart beats. Also, a main point is the increasing systolo-diastolic movements of the valvular tissue, particularly at its junction with the rigid part of the IV, and it is therefore necessary to find the most possible resistant material tissue.

**[0108]** As mentioned previously, the valvular structure can also possibly be made with biological tissue such as the pericardium, or with porcine leaflets, which are commonly used in bioprosthetic surgically implanted valves.

**[0109]** Moreover, the valvular prosthesis of the present invention does not induce any significant thrombosis phenomenon during its stay in the blood flow and is biologically neutral.

**[0110]** To prevent the risk of thrombus formation and

of emboli caused by clots, a substance with anti-thrombic properties could be used, such as heparine, ticlopidine, phosphorylcholine, etc. either as a coating material or it can be incorporated into the material used for the implantable valve, in particular, for the valvular structure and/or for the internal cover.

**[0111]** The valvular structure of the invention can have several types of designs and shapes. Besides the example illustrated in Figures 4 and 5, examples of strengthened valvular structures according to the invention are shown in Figures 9 to 11, respectively in the closed (figures 9a, 10a, 11a) and in the open state (figures 9b, 10b, 11b) to form a prosthetic valve according to the present invention. In those figures, the frame line is simplified to clarify the drawings.

**[0112]** To help initiate and finalize the closure of the valvular structure, four strengthening struts 14 are slightly inclined from the base to the upper part as compared to the central axis X'X of the structure, as shown in Figures 9a and 9b. Accordingly, a patterned movement of the valvular structure, during the closing and the opening phases, is initiated. This patterned movement is, in the present case, an helicoidal-type one, as suggested in Figures 9b and 10b by the circular arrow.

**[0113]** Figures 10a and 10b illustrate another embodiment to help the closing of the valvular structure and which also involves an helicoidal movement. Represented by lines 22, inclined pleats are formed in the tissue to impart such a movement. As illustrated, these lines have an inclination from the base to the upper part of the tissue 14. Pleats are formed by folding the tissue or by alternating thinner and thicker portions. The width and the number of those pleats are variable, and depend particularly on the type of material used. According to another example, these pleats 34 are combined with the above described inclined strengthening struts.

**[0114]** These reinforcing pleats and/or struts, rectilinear or inclined, have the advantage to impart a reproducible movement and, accordingly, to avoid the valvular structure from closing to a nonstructured collapse on the frame base.

**[0115]** Another shape of the valvular structure comprises two portions: one portion being flexible but with some rigidity, having a rectangular shape, occupying about one third of the circumference of the valvular structure, and the other portion being more supple, flexible and foldable occupying the rest of the circumference at its base as well as at its upper, free border. According to Figure 11c, this valve is opened, during the ejection of blood, i.e., during systol. In Figure 11d, a front view of the valve is closed, during an intermediate diastole, and in Figure 11e the same closed valve during diastole is shown from a side view. The semi-rigid part 24' moves little during systole and during diastole. The foldable part 23' moves away from the rigid part during systole to let the blood flow through the orifice thus made. This orifice, due to the diameter of the upper part which is the same as that of the open stent, is large, generally as large as

that of the open stent. At the time of diastole, due to the reverse of pressure, the foldable part moves back towards the semi-rigid part and presses on it, and thus closes the orifice and prevents any regurgitation of blood.

**[0116]** The advantage of such a valve design is to allow a large opening of the upper part of the valvular structure, not only to permit more blood flow at time of systole after the valve has been implanted, but also at the very time of implantation, when the balloon is maximally inflated to expand the valve to imbed it in the valvular annulus. The diameter of the upper part of the valvular structure could be the same size as the balloon, so that there would be no distension of the valvular part of the valve at the time of implantation, and therefore no risk of deterioration of the valvular structure by the inflated balloon.

**[0117]** The foldable part of the valve could be reinforced by strengthening struts to prevent an eversion of the valve towards the left ventricle during diastole.

**[0118]** Another shape of the valvular structure, as illustrated in Figures 11a and 11b comprise four portions, alternatively a main portion 23 and a more narrow portion 24. The main and the narrow portions are facing each other. Each portion has an isosceles trapezoidal shape. The main portions 23 are flexible but with some slight rigidity and the more narrow portions 24 are compliant, more supple and foldable. In this type of design, the two slightly rigid portions 23 maintain the valvular structure closed during diastole by firmly applying on each other in their upper extremities, thus forming a slot-like closure 25. This particular embodiment needs less foldable tissue than in the previous embodiments and the closure of the valvular structure at the time of early diastole does not have any tendency to collapse towards the aortic annulus.

**[0119]** Another design for the valvular structure is a combination of a cylindrical shape followed by a truncated shape.

**[0120]** This type of valvular structure is longer than the hyperboloidal type, for instance, 25 or 30 mm long, therefore exceeding out of the upper part of the metallic frame, by 10 to 20 mm. The cylindrical part corresponds to the metallic frame and remains inside it. The truncated conic shape is the upper part of the valvular structure, totally exceeding out of the upper extremity of the metallic frame. An advantage of such a design is that the balloon can be inflated only in the cylindrical part of the valvular structure, therefore without risk of stretching the truncated conical part of the upper diameter which is smaller than that of the inflated balloon.

**[0121]** When the upper extremity of the cylindrical part has the same size as the lower extremity, there is no difference during balloon inflation in the degree of force exerted by the balloon on the lower and on the upper extremity of the valvular structure. Preferably, rectilinear reinforcing struts are used in this embodiment, to strengthen the valve structure and aid in its shutting without collapsing and inverting inside the left ventricle through the aortic annulus under the force of the diastolic

pressure.

**[0122]** Two different processes for implanting a valve are shown respectively in Figures 13a to 13l with a unique balloon catheter, as illustrated in Figures 12a and 12b and in Figures 15a to 15f, with a two-balloon catheter according to the present invention, as illustrated in Figure 14.

**[0123]** The IV positioning in the aortic orifice and its expansion can be performed with the help of a unique substantially cylindrical balloon catheter 26 in the so-called unique-balloon catheterization technique.

**[0124]** Preparing for its introduction by transcatheter route in the femoral artery, the IV 13 is, as illustrated in the perspective view of Figure 10a in a compressed form crimped on the balloon catheter 26. A central sectional view of the mounted IV 13 on the complete balloon catheter 26 is shown in Figure 12b.

**[0125]** The shaft 27f of the balloon dilatation catheter 26 is as small as possible, i.e., a 7F (2.2 mm) or a 6 F (1.9 mm) size. The balloon 26 is mounted on the shaft 27 between two rings R. Moreover, the shaft 27 comprises a lumen 28 (Figure 12b) as large as possible for inflation of the balloon 26 with diluted contrast to allow simple and fast inflation and deflation. It has also another lumen 29 able to accept a stiff guide wire 30, for example 0.036 to 0.038 inches (0.97 mm), to help position the implantable valve with precision.

**[0126]** The balloon 26 has, for example, a 3 to 4 cm length in its cylindrical part and the smallest possible size when completely deflated so that it will be able to be placed inside the folded valve having an outside diameter which ranges between about 4 and 5 mm. Therefore, the folded balloon preferably has at the most a section diameter of about 2.5 to 3 mm.

**[0127]** The balloon is therefore made of a very thin plastic material. It is inflated with saline containing a small amount of contrast dye in such a way to remain very fluid and visible when using X-ray.

**[0128]** However, the balloon 26 has to be sufficiently strong to resist the high pressure that it has to withstand to be capable of expanding the folded valvular structure 14 and the compressed frame in the stenosed aortic orifice considering that, although pre-dilated, the aortic orifice still exerts a quite strong resistance to expansion because of the recoil phenomenon.

**[0129]** This procedure is shown in Figures 13a to 13e.

**[0130]** In contrast to the technique used when performing the usual aortic dilatation (without valve implantation), i.e., inflating the balloon maximally markedly above the nominal pressure, if possible, up to the bursting point (which occurs always with a longitudinal tear, without deleterious consequence, and with the advantage of both exerting a maximal dilating force and restoring blood ejection instantaneously), the balloon inflated for expansion of an implantable valve should not burst in any case. Indeed, bursting of the balloon would involve a risk of incomplete valve expansion and wrong positioning. Therefore, the balloon should be very resistant to a very

high pressure inflation. Furthermore, the balloon is inflated only up to the nominal pressure indicated by the maker and the pressure is controlled during inflation by using a manometer. Such relatively low pressure should be sufficient since prior to positioning the IV, an efficacious dilatation of the stenosed aortic valve according to the usual technique with a maximally inflated balloon for example 20 mm or 25 mm in size in such a way to soften the distorted valvular tissue and facilitate the enlargement of the opening of the valve at time of IV implantation is performed.

**[0131]** The implantation of the aortic valve 20 can be made in two steps, as described as follows.

**[0132]** The first step, as shown in Figures 13a to 13f, consists in introducing the shaft 27 and balloon catheter 26 along the guide wire previously positioned in the ventricle 4 (Figures 13a-13b). The dilatation of the stenosed aortic valve 1', 2' using a regular balloon catheter, according to the commonly performed procedure, i.e., with the guide wire 30 introduced in the ventricle 4 (Figure 13a) and with maximal inflation of the balloon 26 (Figures 13c to 13d) up to the bursting point. Dilatation is performed at least with a balloon having about 20 mm diameter, but it can be performed with a balloon having about 23 mm diameter so as to increase maximally the aortic orifice opening before implantation of the valve although the implantable valve is about 20 mm in diameter. This preliminary dilatation of the aortic orifice helps in limiting the force required to inflate the balloon used to expand the implantable valve and position it in the aortic orifice, and also in limiting the recoil of the aortic valve that occurs immediately after balloon deflation. The balloon is deflated (Figure 13a) and pulled back on the wire guide 30 left inside the ventricle.

**[0133]** Owing to the marked recoil of the stenosed valve and also of the strong aortic annulus, the 20 mm diameter valve is forcefully maintained against the valvular remains at the level of the aortic annulus. Preliminary dilatation has another advantage in that it permits an easier expansion of the IV, having a lower pressure balloon inflation which helps prevent damage of the valvular structure of the IV. This also facilitates the accurate positioning of the prosthetic valve.

**[0134]** The second step corresponds to the implantation of the valve 13 is shown in Figures 13g to 13l. The positioning of the IV needs to be precise at a near 2 or 3 mm, since the coronary ostia 6 has to remain absolutely free of any obstruction by the valve 13 (Figures 13k and 13l). As mentioned above, this is, for example, performed with the help of the image of the sus-valvular angiogram in the same projection fixed on an adjacent TV screen. The expansion and the positioning of the valve prosthesis 13 is performed within a few seconds (15 to 20 among at most) since during the maximal balloon inflation (which has to be maintained only a very few seconds, 3, 4, 5) the aortic orifice is obstructed by the inflated balloon 31 and the cardiac output is zero (Figure 13h). As for the pre-dilatation act itself, the balloon 26 is immediately de-

inflated within less than 5 or 6 seconds (Figure 13j) and, as soon as the deflation has clearly begun, the closing and opening states of the IV are active whereas the balloon is pulled back briskly in the aorta (Figures 13j to 13l).

In case the IV is not maximally expanded by the first inflation, it is possible to replace the balloon inside the IV and to reinflate it so as to reinforce the expansion of the IV.

**[0135]** The IV 13 can also be used in aortic regurgitation. This concerns more often younger patients rather than those with aortic stenosis. The contraindication to surgical valve replacement is often not due to the old age of the patients, but stems mainly from particular cases where the general status of the patient is too weak to allow surgery, or because of associated pathological conditions. Apart from the fact that there is no need for a preliminary dilatation, the procedure of the valve implantation remains approximately the same. The balloon inflation inside the IV is chosen accordingly, taking also into account the fact that it is necessary to overdilute the aortic annulus to obtain a recoil phenomenon of the annulus after balloon deflation to help maintain the IV in position without any risk of displacement.

**[0136]** However, the size of the expanded implantable valve is around 25 to 30 mm in diameter, or even bigger, because the aortic annulus is usually enlarged. A preliminary measurement of the annulus will have to be performed on the sus-valvular angiography and by echocardiography to determine the optimal size to choose.

**[0137]** The IV can be used in the mitral position, mainly in case of mitral regurgitation, but also in case of mitral stenosis. Here again, the IV 20 is only described when used only in cases of contraindication to surgical valve repair or replacement. The procedure is based on the same general principles though the route for the valve positioning is different, using the transseptal route, like the commonly performed mitral dilatation procedure in mitral stenosis. The IV size is quite larger than for the aortic localization (about 30 to 35 mm in diameter when expanded or clearly above in case of a large mitral annulus, a frequent occurrence in mitral insufficiency), to be capable of occupying the mitral area. A preliminary measurement of the mitral annulus is performed to determine the optimal implantable valve size to choose. Since the introduction of the IV is performed through a venous route, almost always through the femoral vein which is quite large and distensible, the bigger the size of the IV in its compressed position is not a drawback even if the diameter size is about 6 or 7 mm. Moreover, the problem of protection of the coronary ostia as encountered in the aortic position does not exist here which therefore makes the procedure easier to be performed.

**[0138]** Finally, the IV can be used to replace the tricuspid valve in patients with a tricuspid insufficiency. This procedure is simple to perform since the positioning of the IV is made by the venous route, using the shortest way to place in the right position at the level of the tricuspid orifice practically without any danger from clot migra-

tion during the procedure. A large implantable valve is used, with a diameter of about 40 mm or even larger because the tricuspid annulus is often markedly dilated in tricuspid insufficiency. Here also, as in the mitral position, the compressed IV and the catheter used can be

without inconvenience, quite larger than that for the aortic position because of the venous route used.  
**[0139]** Furthermore, it has to be noted that the IV can be used also as a first step in the treatment of patients who have contraindication to surgery, when they are examined for the first time, but who could improve later on after correction of the initial hemodynamic failure. The IV procedure can be used as a bridge towards surgery for patients in a weak general condition which are expected to improve within the following weeks or months after the IV procedure in such a way that they can be treated by open heart surgery later on. In the same vein, the IV procedure can be used as a bridge towards surgical valve replacement or repair in patients with a profoundly altered cardiac function that can improve secondarily owing to the hemodynamic improvement resulting from the correction of the initial valvular disease by the IV implantation.

**[0140]** Another technique for implantation of an aortic valve by transcatheterization uses a two-balloon catheter.

**[0141]** An example of this technique using the two parts IV with a two-balloon catheter 40 is shown in Figure 14.

**[0142]** Two-balloons 26 and 26' are fixed on a unique catheter shaft 27, said balloons being separated by a few millimeters. The two balloons are preferably short, i.e., about 2 to 2.5 cm long in their cylindrical part. The first balloon 26 to be used, carries a first frame 10 aimed at scaffolding the stenosed aortic orifice after initial dilatation. This first balloon 26 is positioned on the aorta side, above the second balloon 26' which is positioned on the left ventricle side. The second balloon 26' carries the expandable valve 13 which is of the type described above made of a second frame 10' and a valvular structure 14 attached to said frame 10'. The difference is that the second frame does not need to be as strong as the first frame and is easier to expand with low balloon pressure inflation which does not risk damaging the valvular structure 14.

**[0143]** This enlarges the choice for making a valvular structure without having to face two contradictory conditions:

- 1) having a soft and mobile valvular structure 14 capable of opening and closing freely in the blood stream without risk of being damaged by a balloon inflation; and
- 2) needing a reinforced frame strong enough to be capable of resisting without any damage, a strong pressure inflation of the expanding balloon.

**[0144]** The shaft 27 of this successive two-balloon catheter 40 comprises two lumens for successive and

separate inflation of each balloon. Indeed, an additional lumen capable of allowing a fast inflation occupies space in the shaft and therefore an enlargement of the shaft is necessary. However, this enlargement of the shaft stops at the level of the first balloon 26 since, further to said first balloon, only one lumen is necessary to inflate the second balloon 26', at the level of the IV which is the biggest part of the device.

**[0145]** Another advantage of this two part IV with a two-balloon catheter is that each set of implantable valve and balloon has a smaller external diameter since each element to be expanded, considered separately, is smaller than in combination. This allows obtaining more easily a final device with an external diameter 14 F.

**[0146]** The first balloon is sufficiently strong to avoid bursting even at a very high pressure inflation. This first balloon is mounted in the frame in its deflated position, prior to its introduction by the strong frame which is aimed to scaffold the dilated stenosed aortic valve. The size and shape of said frame is comparable to what has been described previously but said frame is calculated (in particular the material, the number and diameter of its bars are chosen by the person skilled in the art) to make sure that it will resist the recoil of the dilated valve and that it will be securely embedded in the remains of the native aortic valve.

**[0147]** The second balloon does not need to be as strong as the first one and, therefore, can be thinner, occupying less space and being easier to expand with a lower pressure for balloon inflation. This second balloon 26' is mounted in the valve itself which, as in the preceding description, comprises a frame to support the valvular structure and said valvular structure.

**[0148]** Also, the second frame 10' does not need to be as strong as the first one. This frame can be slightly shorter, 10 mm instead of 12 mm, and its bars are thinner. This frame can have an external surface which is a bit rough to allow better fixation on the first frame when expanded. The bars may also have some hooks to fasten to the first frame.

**[0149]** The valvular structure is attached on said second frame and expanded by relatively low pressure in the second balloon called hereafter the IV balloon. It does not need to be as strong as in the preceding case (IV in one part and unique balloon catheter technique) and, therefore, it occupies less space and has less risk to be damaged at the time of expansion.

**[0150]** This technique is shown in Figures 15a to 15f.

**[0151]** One of the problems relevant to the IV implantation procedure as described above, with the IV in one part, is the expansion at the same time by the same balloon inflation of both the frame and the valvular structure. Indeed, the frame is a solid element and the valvular structure is a relative weak one that could be damaged when squeezed by the inflated balloon.

**[0152]** Therefore, the valve implantation can be performed in two immediately successive steps. The first step (Figures 15a-15b) corresponds to the expansion

and the positioning of the first frame with the first balloon 26 wherein inflation is performed at a high pressure. The second step (Figures 15d-15e) corresponds to the expansion and the positioning of the valvular structure 14 inside the frame 10' using the second balloon 26'. This second step follows the first one within a few seconds because, in the time interval between the two steps, there is a total aortic regurgitation towards the left ventricle which is an hemodynamic condition that cannot be maintained for more than a few heart beats, i.e., a few seconds, without inducing a massive pulmonary edema and a drop to zero of the cardiac output.

**[0153]** In another embodiment, the first frame to be introduced comprises the valvular structure and the second frame being stronger than the first one to scaffold the previously deleted stenosed aortic valve.

**[0154]** The advantage of this two step procedure would be to allow expansion and positioning of the frame part 10' of the IV 13 using strong pressure inflation of the balloon 26' without the risk of damaging the valvular structure 14 which, for its own expansion, would need only light pressure inflation.

**[0155]** The method is schematically detailed in Figures 15a to 15f. A previous dilatation of the stenosed aortic valve is performed as an initial step of the procedure to prepare the distorted valve to facilitate the following steps:

1/ positioning the double balloon catheter 40 with the first balloon 26 with the frame at the level of the aortic annulus 2a, the second IV balloon 26' being inside the left ventricle beyond the aortic annulus 2a (Figure 15a);

2/ compression of the stenosed aortic valve 1', 2' with the first balloon 26 having a 20 mm, preferably with a 23 mm diameter, the balloon being inflated maximally up to the bursting point, to prepare the IV insertion (Figure 15b). Inflation lasts a few seconds (preferably 10 seconds at most) with powerful pressure being used to expand the frame and forcefully embed said frame in the remains of the dilated valve; 3/ an immediate speedy deflation of said first balloon 26 follows (Figure 15c); as soon as the balloon 26 is beginning to clearly deflate, the first frame 10 remaining attached to the stenosed valve 1', 2', the catheter 40 is withdrawn to position the IV balloon 26' inside the previously expanded frame 26 (Figure 15c in which the frame 10' is partially drawn for clarity purpose);

4/ immediately after being well positioned, the IV balloon 26' is promptly inflated, to expand the IV 13 (Figure 15c); and

5/ when the IV 13 is blocked inside the first frame 10, the IV balloon 26' is deflated (Figure 18f).

**[0156]** Finally, the whole device has to be withdrawn to allow hemostasis of the femoral artery puncture hole.

**[0157]** The total duration of the successive steps, par-

ticularly the time during which the balloons are inflated, and the time during which the frame is expanded whereas the valve has not yet been positioned and expanded, is about 20 to 30 seconds. This is feasible if the balloons are inflated and deflated within very a few seconds, 6 to 8, for instance. This is permitted if the lumen of the shaft can be sufficiently large, taking into account the inescapable small diameter size of the shaft. This can also be facilitated by a device producing instantaneously a strong inflation or deflation pressure.

#### Claims

1. A two-part implantable valve configured for implantation within a native semi-lunar heart valve using a balloon catheter, the implantable valve comprising a first expandable metal frame (10) having a substantially cylindrical shape and configured to expand to a size of between about 20 and 35 mm in diameter to contact semi-lunar leaflets (1', 2') of the native semi-lunar heart valve and to embed in a semi-lunar heart valve annulus (2a), the first expandable metal frame (10) comprising a plurality of intercrossing bars (11) which are sufficiently strong and rigid in an expanded state to resist the recoil forces exerted by the semi-lunar leaflets of the native semi-lunar heart valve, **characterized in that** the two-part implantable valve comprises an expandable supple valvular structure (14) comprising valvular tissue made of a biological material and capable of opening and closing in the bloodstream, the valvular tissue attached to a second expandable metal frame (10'), the second expandable metal frame (10') comprising a plurality of intercrossing bars which are thinner than those of the first expandable metal frame, the second expandable metal frame configured to be expanded within the first expandable metal frame after the first expandable metal frame (10) has been expanded in the semi-lunar heart valve annulus.
2. The two-part implantable valve according to claim 1, **characterized in that** the plurality of intercrossing bars (11) of the first frame (10) have diameters in the range of about 0,1 to 0,6 mm.
3. The two-part implantable valve according to claim 1 or 2, **characterized in that** the first frame (10) has a height of approximately between 10 and 15 mm in the expanded state.
4. The two-part implantable valve according to any one of claims 1 to 3, **characterized in that** the first frame (10) is made of stainless steel.
5. The two-part implantable valve according to any one of claims 1 to 4, **characterized in that** the first frame (10) has a diameter of between about 4 and 5 mm



when in a collapsed state.

6. The two-part implantable valve according to any one of claims 1 to 5, **characterized in that** the first frame (10) is made of a material which is distinguishable from biological tissue by non-invasive imaging techniques. 5
7. The two-part implantable valve according to any one of claims 1 to 6, **characterized in that** the second frame (10') is shorter than the first frame (10). 10
8. The two-part implantable valve according to any one of claims 1 to 7, **characterized in that** the second frame (10') has a rough external surface. 15
9. The two-part implantable valve according to any one of claims 1 to 8, **characterized in that** the bars of the second frame (10') have hooks to fasten to the first frame (10). 20
10. The two-part implantable valve according to any one of claims 1 to 9, **characterized in that** it further comprises an internal cover (19) coupled to the valvular structure (14), the internal cover being located between the valvular structure and an internal wall of the second frame (10') to prevent passage of blood through the intercrossing bars of the metal frame (10'). 25
11. The two-part implantable valve according to claim 10, **characterized in that** a proximal end portion of the internal cover (19) is rolled over a proximal end of the second frame (10') for contacting an outer surface of the metal frame (10'). 30
12. The two-part implantable valve according to claim 10 or 11, **characterized in that** the valvular structure (14) and/or the internal cover (19) are coated with or are made of an anti-thrombotic substance. 35
13. The two-part implantable valve according to any one of claims 1 to 12, **characterized in that** the valvular tissue is made of pericardium or porcine leaflets. 40
14. The two-part implantable valve according to any one of claims 1 to 13, **characterized in that** the valvular structure (14) is fastened to the second frame (10') by sewing, by molding, soldering or by gluing, to prevent regurgitation of blood between the second frame (10') and the valvular structure. 45
15. A balloon catheter, **characterized in that** the balloon catheter comprises two balloons (26, 26') fixed on a catheter shaft (27) and a two-part implantable valve according to any one of claims 1 to 14. 50
16. The balloon catheter according to claim 15, **charac-** 55

**terized in that** the catheter shaft (27) comprises two lumens for successive and separate inflation of each balloon and an additional lumen (29) for passage of a guide wire (30).

17. The balloon catheter according to claim 15 or 16, **characterized in that** it further comprises at least one metallic reference mark for enhanced visibility under fluoroscopy.

#### Patentansprüche

1. Zweiteilige implantierbare Klappe, die zur Implantierung innerhalb einer arteigenen Herz Taschenklappe unter Verwendung eines Ballonkatheters konfiguriert ist, wobei die implantierbare Klappe einen ersten spreizbaren Metallrahmen (10) umfasst, der eine im Wesentlichen zylindrische Form aufweist, und konfiguriert ist, um sich auf eine Größe zwischen etwa 20 und 35 mm im Durchmesser zu spreizen, um Taschenklappenflügel (1', 2') der arteigenen Herz Taschenklappen zu kontaktieren, und um sich in einen Herz Taschenklappenring (2a) einzubetten, wobei der erste spreizbare Metallrahmen (10) eine Vielzahl von einander kreuzenden Stäben (11) umfasst, die in einem gespreizten Zustand hinreichend stark und steif sind, um den Rückstoßkräften zu widerstehen, die durch die Taschenklappenflügel der arteigenen Herz Taschenklappe ausgeübt werden, **dadurch gekennzeichnet, dass** die zweiteilige implantierbare Klappe eine spreizbare, biegsame Klappenstruktur (14) umfasst, die ein Klappengewebe umfasst, das aus einem biologischen Material besteht und in der Lage ist, sich in dem Blutstrom zu öffnen und zu schließen, wobei das Klappengewebe an einem zweiten spreizbaren Metallrahmen (10') befestigt ist, wobei der zweite spreizbare Metallrahmen (10') eine Vielzahl von einander kreuzenden Stäben umfasst, die dünner als jene des ersten spreizbaren Metallrahmens sind, wobei der zweite spreizbare Metallrahmen konfiguriert ist, um innerhalb des ersten spreizbaren Metallrahmens gespreizt zu werden, nachdem der erste spreizbare Metallrahmen (10) in dem Herz Taschenklappenring gespreizt wurde. 15
2. Zweiteilige implantierbare Klappe gemäß Anspruch 1, **dadurch gekennzeichnet, dass** die Vielzahl voneinander kreuzenden Stäben (11) des ersten Rahmens (10) Durchmesser in dem Bereich von etwa 0,1 bis 0,6 mm aufweisen. 20
3. Zweiteilige implantierbare Klappe gemäß Anspruch 1 oder 2, **dadurch gekennzeichnet, dass** der erste Rahmen (10) eine Höhe zwischen etwa 10 und 15 mm in dem gespreizten Zustand aufweist. 25

4. Zweiteilige implantierbare Klappe gemäß zumindest einem der Ansprüche 1 bis 3, **dadurch gekennzeichnet, dass** der erste Rahmen (10) aus rostfreiem Stahl besteht.
5. Zweiteilige implantierbare Klappe gemäß zumindest einem der Ansprüche 1 bis 4, **dadurch gekennzeichnet, dass** der erste Rahmen (10) einen Durchmesser zwischen etwa 4 und 5 mm in einem gefalteten Zustand aufweist.
6. Zweiteilige implantierbare Klappe gemäß zumindest einem der Ansprüche 1 bis 5, **dadurch gekennzeichnet, dass** der erste Rahmen (10) aus einem Material besteht, das mittels nichtinvasiver Bildgebungstechniken von biologischem Gewebe unterscheidbar ist.
7. Zweiteilige implantierbare Klappe gemäß zumindest einem der Ansprüche 1 bis 6, **dadurch gekennzeichnet, dass** der zweite Rahmen (10') kürzer als der erste Rahmen (10) ist.
8. Zweiteilige implantierbare Klappe gemäß zumindest einem der Ansprüche 1 bis 7, **dadurch gekennzeichnet, dass** der zweite Rahmen (10') eine raue äußere Oberfläche aufweist.
9. Zweiteilige implantierbare Klappe gemäß zumindest einem der Ansprüche 1 bis 8, **dadurch gekennzeichnet, dass** die Stäben des zweiten Rahmens (10') Haken aufweisen, um in den ersten Rahmen (10) einzugreifen.
10. Zweiteilige implantierbare Klappe gemäß zumindest einem der Ansprüche 1 bis 9, **dadurch gekennzeichnet, dass** sie weiterhin eine innere Abdeckung (19) umfasst, die an die Klappenstruktur (14) gekoppelt ist, wobei die innere Abdeckung zwischen der Klappenstruktur und einer Innenwand des zweiten Rahmens (10') befindlich ist, um einen Blutfluss durch die einander kreuzenden Stäben des Metallrahmens (10') zu verhindern.
11. Zweiteilige implantierbare Klappe gemäß Anspruch 10, **dadurch gekennzeichnet, dass** ein proximaler Endabschnitt der inneren Abdeckung (19) über ein proximales Ende des zweiten Rahmens (10') gerollt ist, um eine äußere Oberfläche des Metallrahmens (10') zu kontaktieren.
12. Zweiteilige implantierbare Klappe gemäß Anspruch 10 oder 11, **dadurch gekennzeichnet, dass** die Klappenstruktur (14) und/oder die innere Abdeckung (19) mit einer antithrombotischen Substanz beschichtet sind/ist oder aus dieser bestehen/besteht.
13. Zweiteilige implantierbare Klappe gemäß zumindest

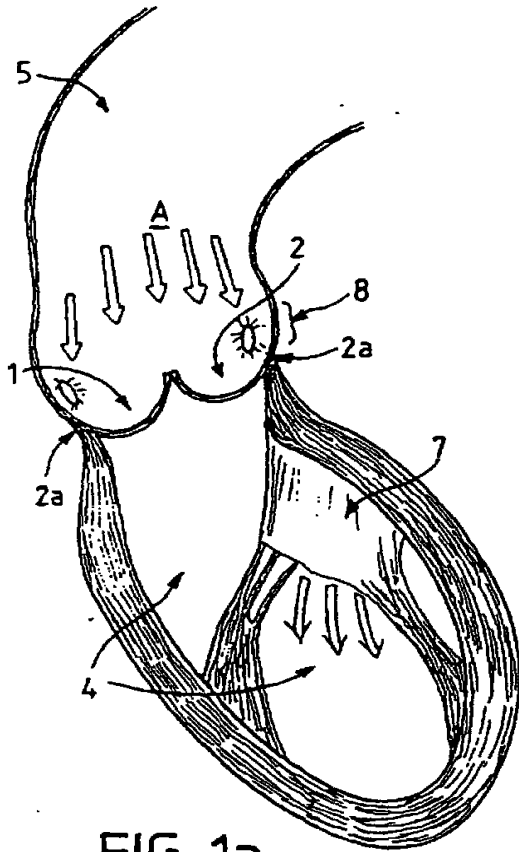
einem der Ansprüche 1 bis 12, **dadurch gekennzeichnet, dass** das Klappengewebe aus Pericardium- oder schweineartigen Klappenflügeln besteht.

- 5 14. Zweiteilige implantierbare Klappe gemäß zumindest einem der Ansprüche 1 bis 13, **dadurch gekennzeichnet, dass** die Klappenstruktur (14) an den zweiten Rahmen (10') durch Nähen, durch Gießen, durch Schmelzen oder durch Kleben befestigt ist, um eine Regurgitation von Blut zwischen dem zweiten Rahmen (10') und der Klappenstruktur zu verhindern.
- 10 15. Ballonkatheter, **dadurch gekennzeichnet, dass** der Ballonkatheter zwei Ballone (26, 26'), die auf einem Katheterschaft (27) fixiert sind, und eine zweiteilige implantierbare Klappe gemäß zumindest einem der Ansprüche 1 bis 14 umfasst.
- 15 16. Ballonkatheter gemäß Anspruch 15, **dadurch gekennzeichnet, dass** der Katheterschaft (27) zwei Lumen zur aufeinanderfolgenden und getrennten Aufblähung eines jeden Ballons und einen zusätzlichen Lumen (29) zur Hindurchführung eines Führdrahtes (30) umfasst.
- 20 17. Ballonkatheter gemäß Anspruch 15 oder 16, **dadurch gekennzeichnet, dass** er weiterhin zumindest eine metallische Referenzmarkierung zur gesteigerten Sichtbarkeit und Fluoroskopie umfasst.
- 25 30

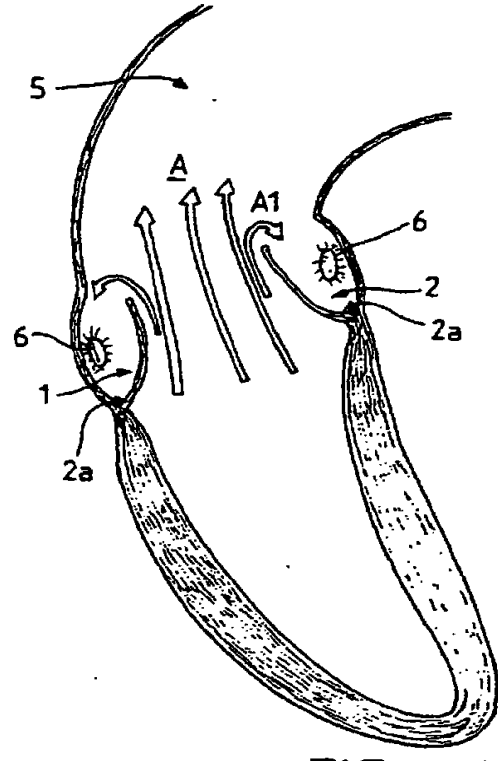
#### Revendications

- 35 1. Valve à deux parties implantable configurée pour une implantation dans une valvule cardiaque native semi-lunaire, en utilisant une sonde à ballonnet, la valve implantable comprenant un premier cadre métallique expansible (10) ayant une forme sensiblement cylindrique et configuré pour s'expanser jusqu'à une taille entre environ 20 et 35 mm de diamètre au contact des valves semi-lunaires (1', 2') de la valvule cardiaque native semi-lunaire et se noyer dans un anneau de la valvule cardiaque semi-lunaire (2a), le premier cadre métallique expansible (10) comprenant une pluralité de barres entrecroisées (11) qui sont suffisamment fortes et rigides dans un état expansé pour résister aux forces de recul exercées par les valves semi-lunaires de la valvule cardiaque native semi-lunaire, **caractérisée en ce que** la valve à deux parties implantable comprend une structure valvulaire souple expansible (14) comprenant un tissu valvulaire fait d'un matériau biologique et capable de s'ouvrir et se fermer dans la circulation sanguine, le tissu valvulaire attaché à un deuxième cadre métallique expansible (10'), le deuxième cadre métallique expansible (10') comprenant une pluralité de barres entrecroisées qui sont plus fines que celles
- 40 45 50 55

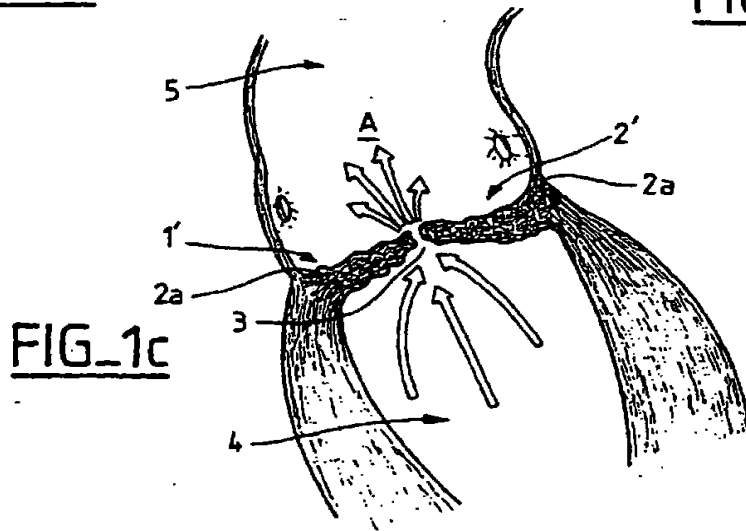
- du premier cadre métallique expansible, le deuxième cadre métallique expansible configuré pour être expansé au sein du premier cadre métallique expansible après que le premier cadre métallique expansible (10) ait été expansé dans l'anneau de valvule cardiaque semi-lunaire.
2. Valve à deux parties implantable selon la revendication 1, **caractérisée en ce que** la pluralité de barres entrecroisées (11) du premier cadre (10) ont des diamètres dans la plage d'environ 0,1 à 0,6 mm. 5
  3. Valve à deux parties implantable selon la revendication 1 ou 2, **caractérisée en ce que** le premier cadre (10) a une hauteur d'approximativement entre 10 et 15 mm à l'état expansé. 10
  4. Valve à deux parties implantable selon l'une quelconque des revendications 1 à 3, **caractérisée en ce que** le premier cadre (10) est fait d'acier inoxydable. 15
  5. Valve à deux parties implantable selon l'une quelconque des revendications 1 à 4, **caractérisée en ce que** le premier cadre (10) a un diamètre entre environ 4 et 5 mm lorsqu'il est dans un état affaissé. 20
  6. Valve à deux parties implantable selon l'une quelconque des revendications 1 à 5, **caractérisée en ce que** le premier cadre (10) est fait d'un matériau qui peut être distingué du tissu biologique par des techniques d'imagerie non-invasives. 25
  7. Valve à deux parties implantable selon l'une quelconque des revendications 1 à 6, **caractérisée en ce que** le deuxième cadre (10') est plus court que le premier cadre (10) . 30
  8. Valve à deux parties implantable selon l'une quelconque des revendications 1 à 7, **caractérisée en ce que** le deuxième cadre (10') a une surface externe rugueuse. 35
  9. Valve à deux parties implantable selon l'une quelconque des revendications 1 à 8, **caractérisée en ce que** les barres du deuxième cadre (10') ont des crochets à attacher au premier cadre (10). 40
  10. Valve à deux parties implantable selon l'une quelconque des revendications 1 à 9, **caractérisée en ce qu'**elle comprend en outre un revêtement interne (19) couplé à la structure valvulaire (14), le revêtement interne étant localisé entre la structure valvulaire et une paroi interne du deuxième cadre (10') pour empêcher le passage du sang à travers les barres entrecroisées du cadre métallique (10'). 45
  11. Valve à deux parties implantable selon la revendication 10, **caractérisée en ce qu'**une portion de l'extrémité proximale du revêtement interne (19) est enroulée sur une extrémité proximale du deuxième cadre (10') pour mettre en contact une surface externe du cadre métallique (10'). 50
  12. Valve à deux parties implantable selon la revendication 10 ou 11, **caractérisée en ce que** la structure valvulaire (14) et/ou le revêtement interne (19) sont enrobés avec ou faits d'une substance anti-thrombotique. 55
  13. Valve à deux parties implantable selon l'une quelconque des revendications 1 à 12, **caractérisée en ce que** le tissu valvulaire est fait de péricarde ou de valves porcines.
  14. Valve à deux parties implantable selon l'une quelconque des revendications 1 à 13, **caractérisée en ce que** la structure valvulaire (14) est attachée au deuxième cadre (10') par couture, par moulage, soudure ou par collage, pour empêcher la régurgitation du sang entre le deuxième cadre (10') et la structure valvulaire.
  15. Sonde à ballonnet, **caractérisée en ce que** la sonde à ballonnet comprend deux ballonnets (26, 26') fixés sur un manche de cathéter (27) et une valve à deux parties implantable selon l'une quelconque des revendications 1 à 14.
  16. Sonde à ballonnet selon la revendication 15, **caractérisée en ce que** le manche de cathéter (27) comprend deux lumières pour le gonflement successif et séparé de chaque ballon et une lumière supplémentaire (29) pour le passage d'un fil guide (30).
  17. Sonde à ballonnet selon la revendication 15 ou 16, **caractérisée en ce qu'**elle comprend en outre au moins une marque de référence métallique pour une visibilité accrue sous fluoroscopie.



FIG\_1a



FIG\_1b



FIG\_1c

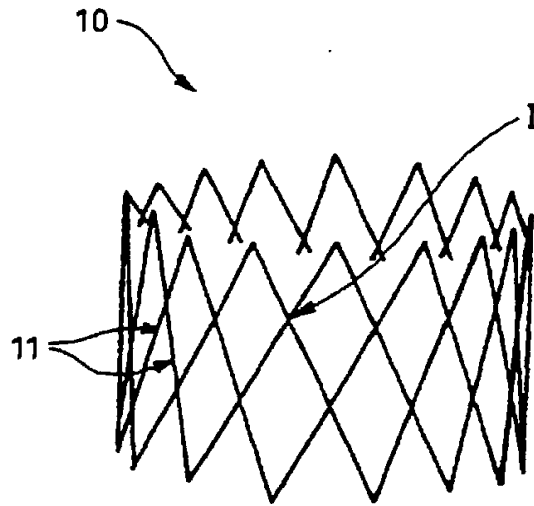


FIG. 2a

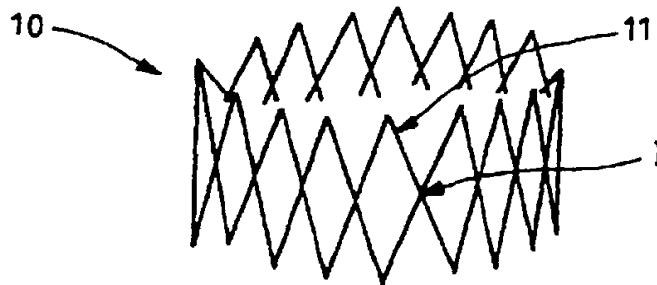
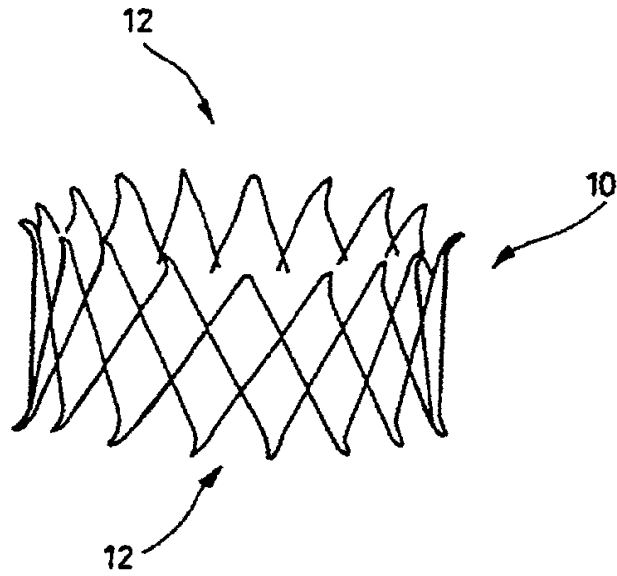
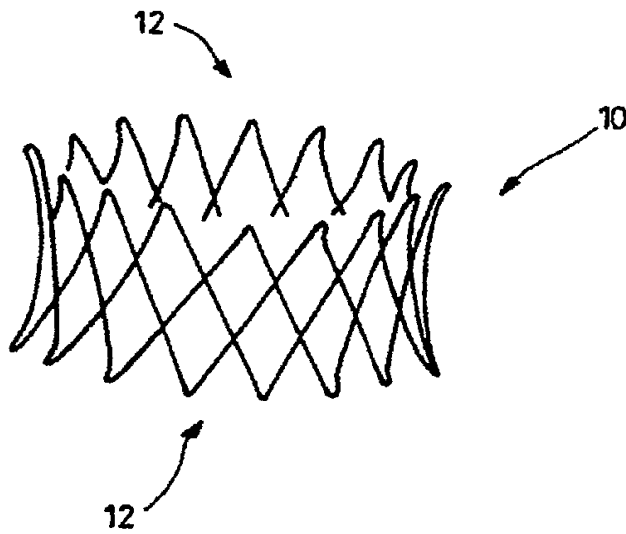


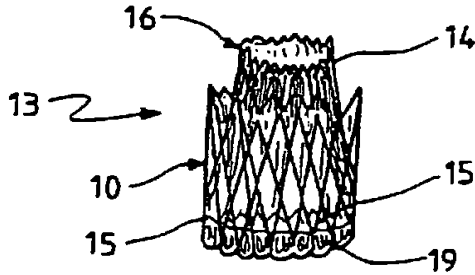
FIG. 2b



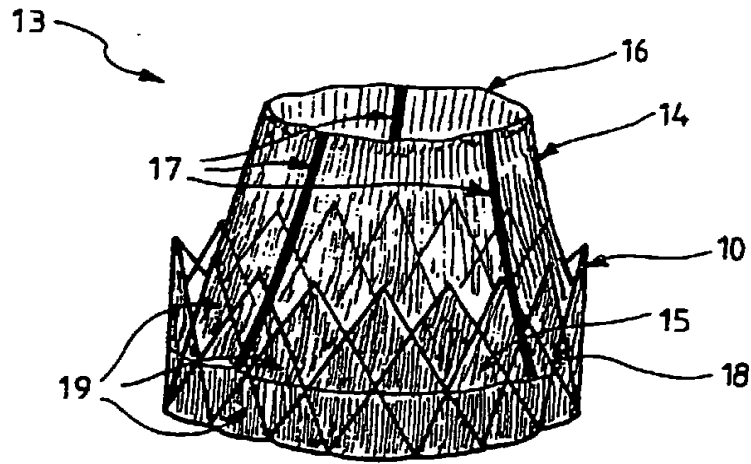
FIG\_3a



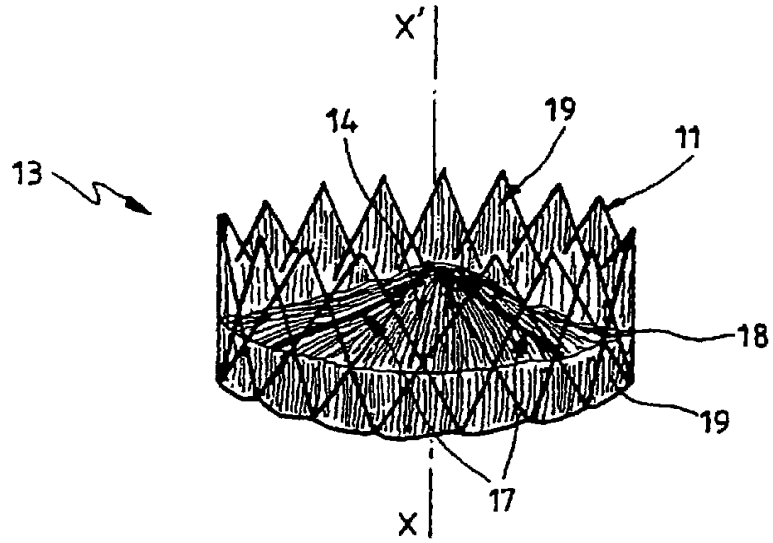
FIG\_3b



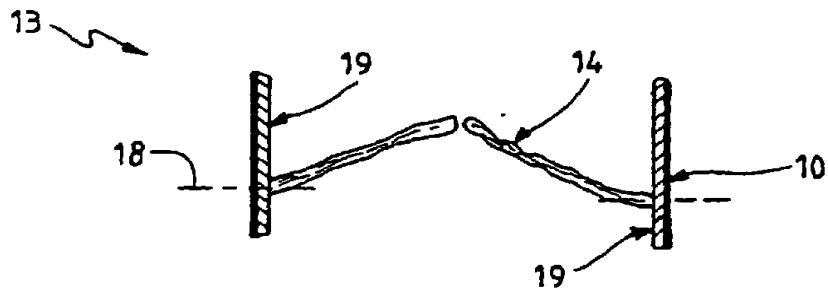
FIG\_4a



FIG\_4b

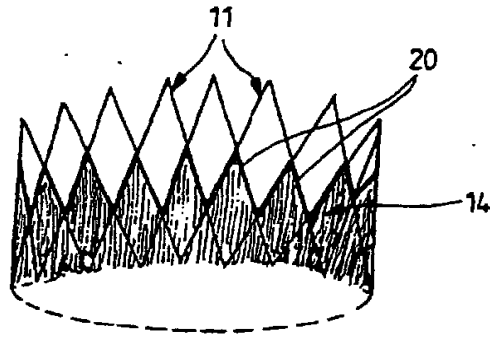


FIG\_5a

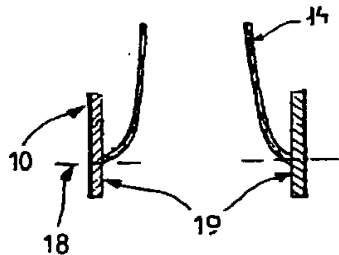


FIG\_5b

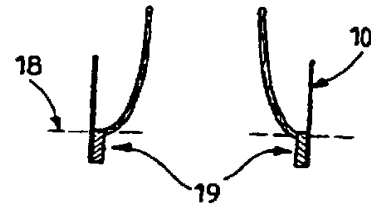




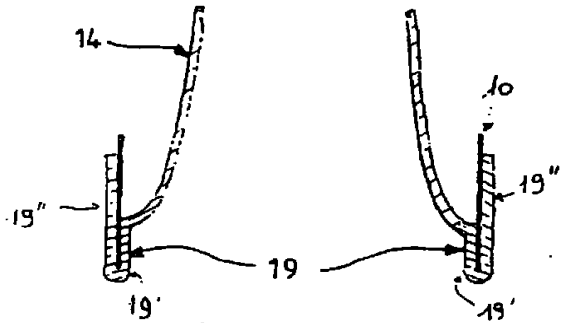
FIG\_7



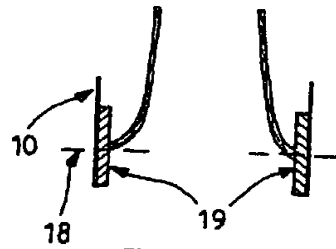
FIG\_6a



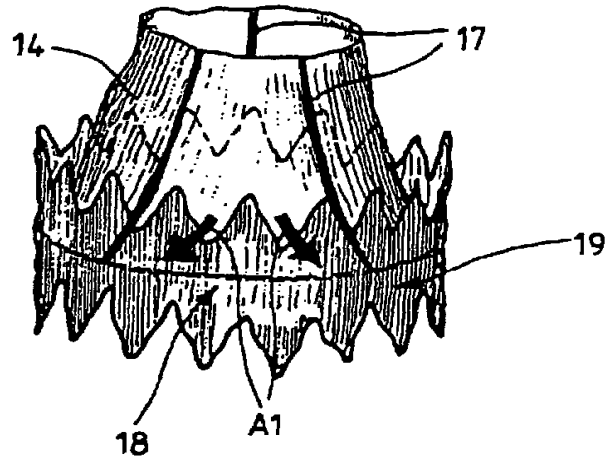
FIG\_6b



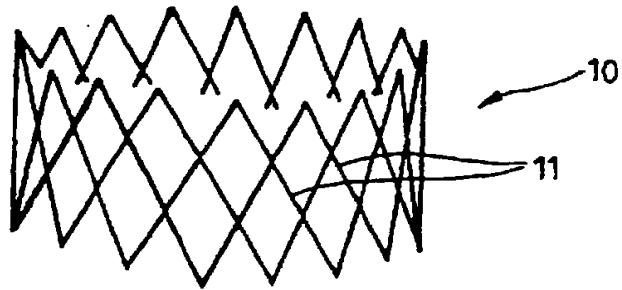
FIG\_6d



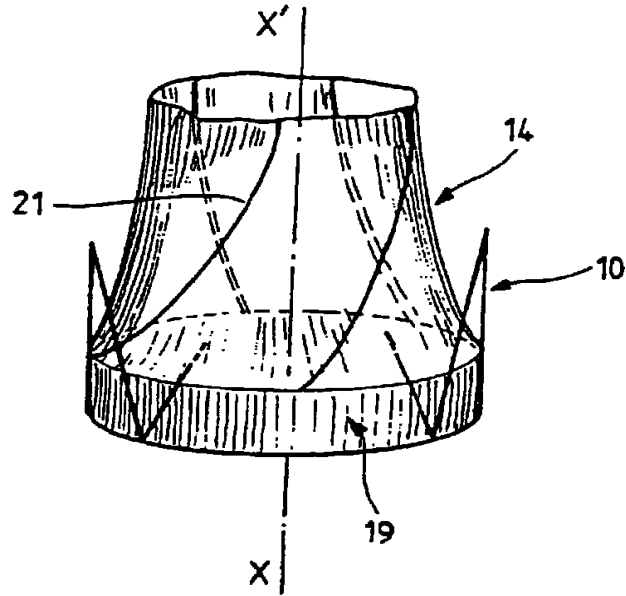
FIG\_6c



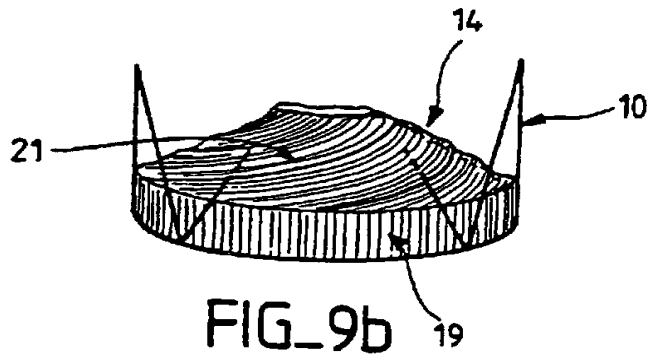
FIG\_8a



FIG\_8b



FIG\_9a



FIG\_9b

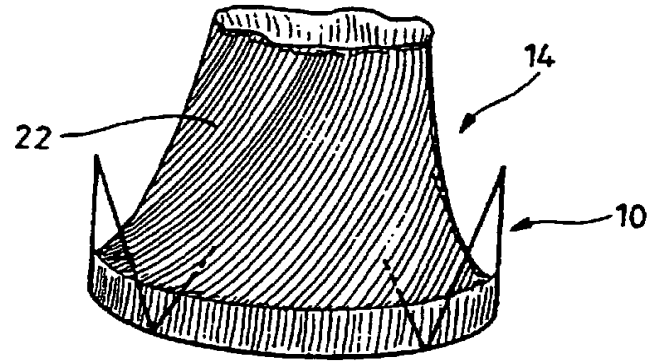


FIG. 10a

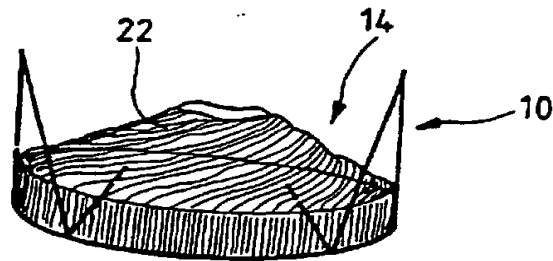
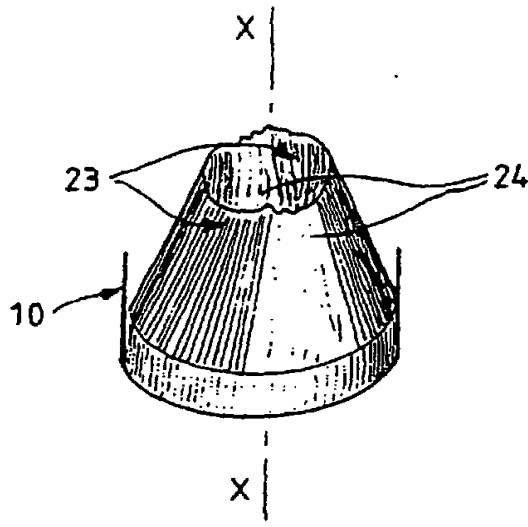
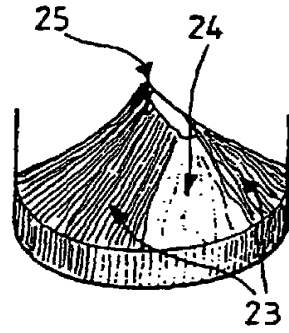


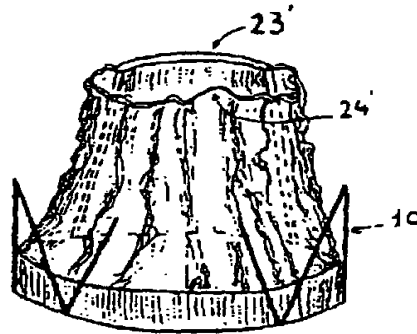
FIG. 10b



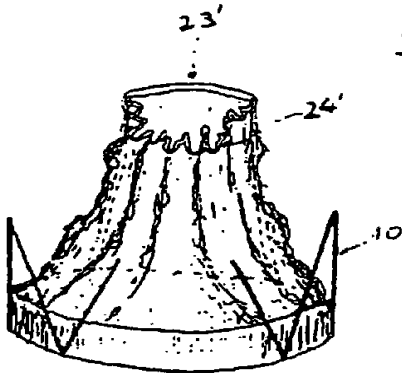
FIG\_11a



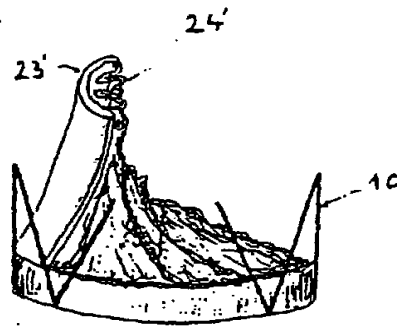
FIG\_11b



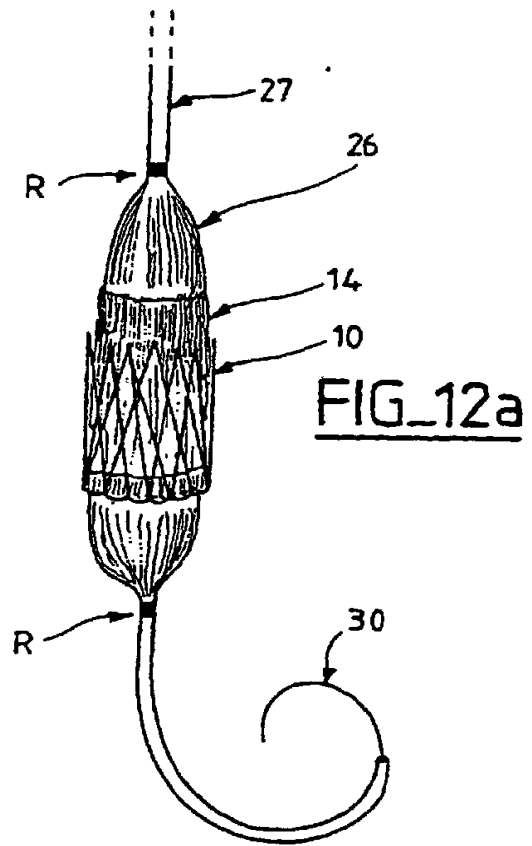
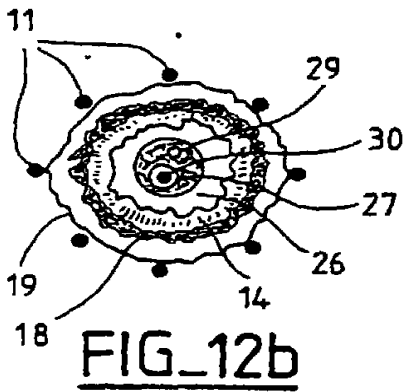
FIG\_11c



FIG\_11d



FIG\_11e



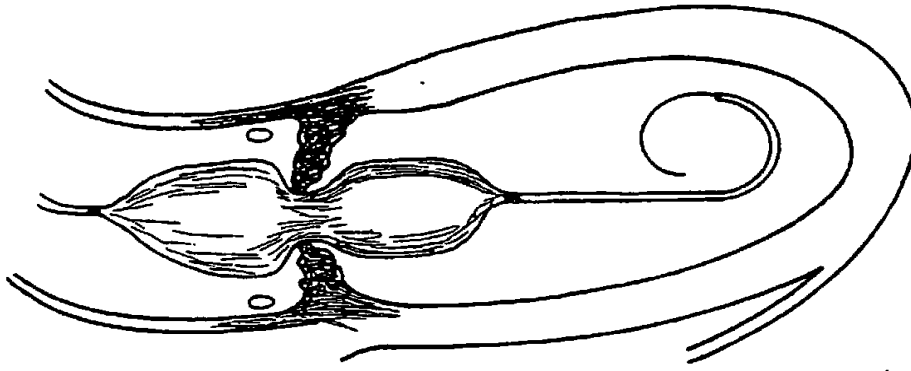


FIG-13c

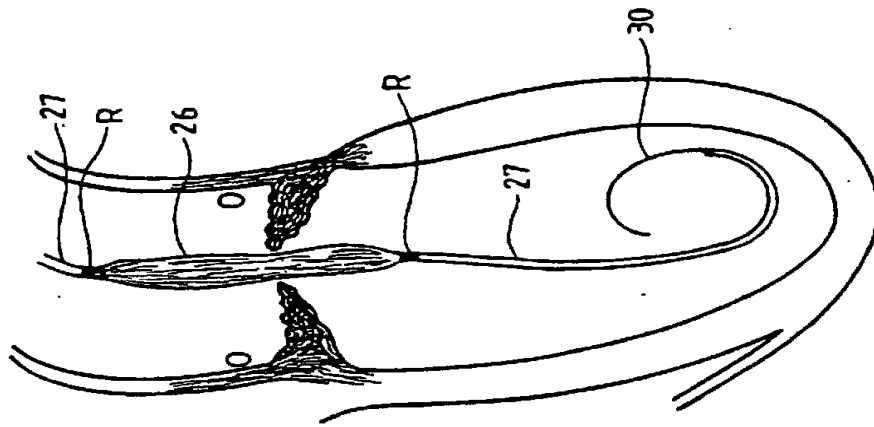


FIG-13b

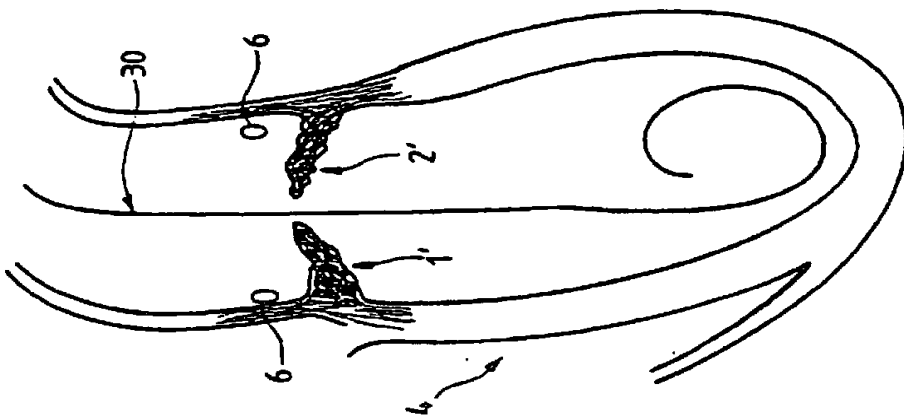


FIG-13a

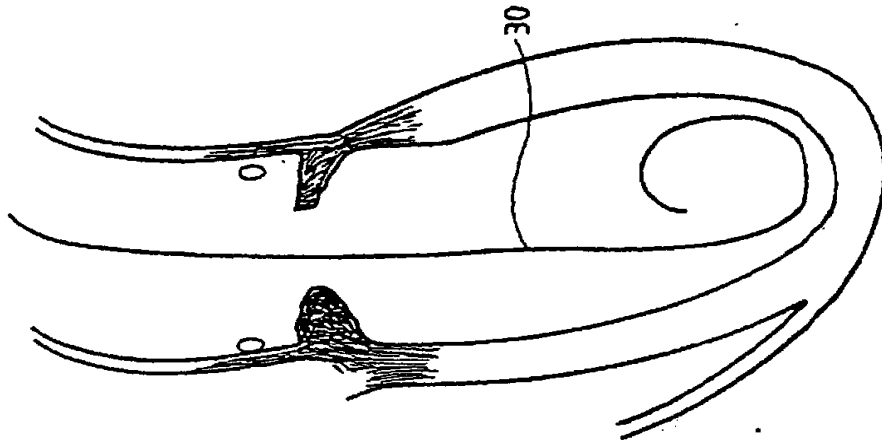


FIG-13f

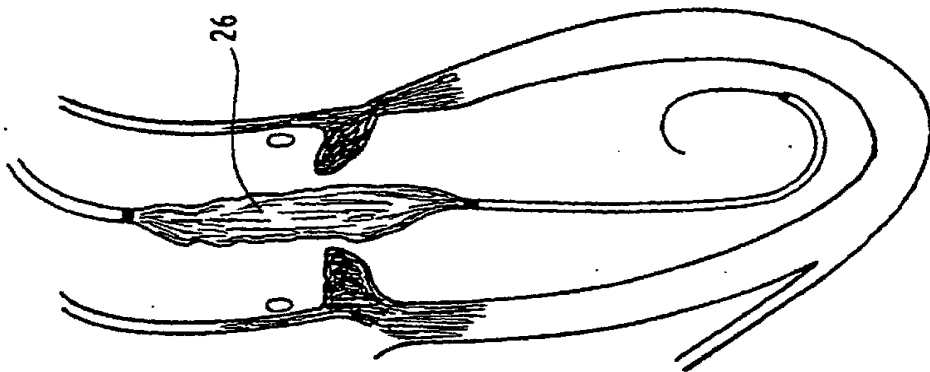


FIG-13e

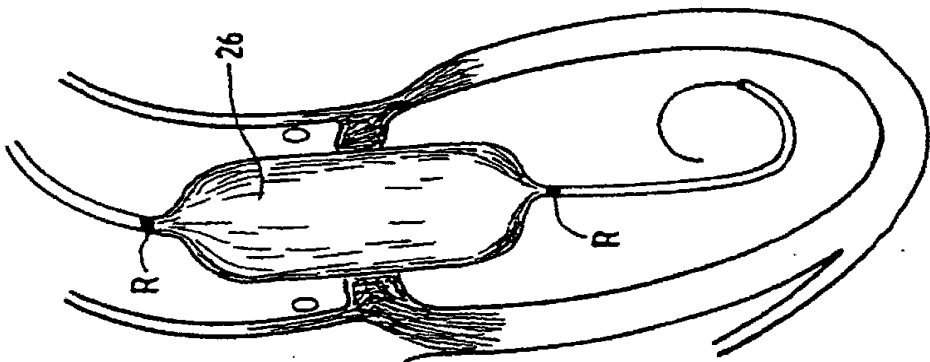


FIG-13d



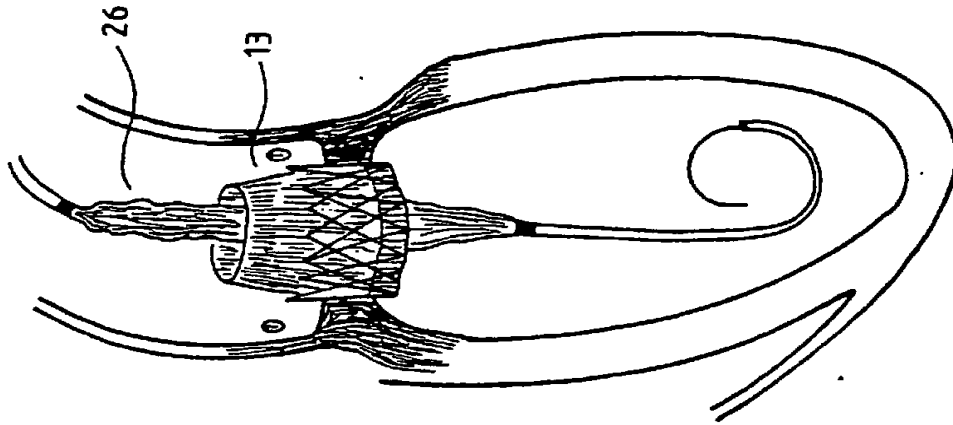


FIG-13i

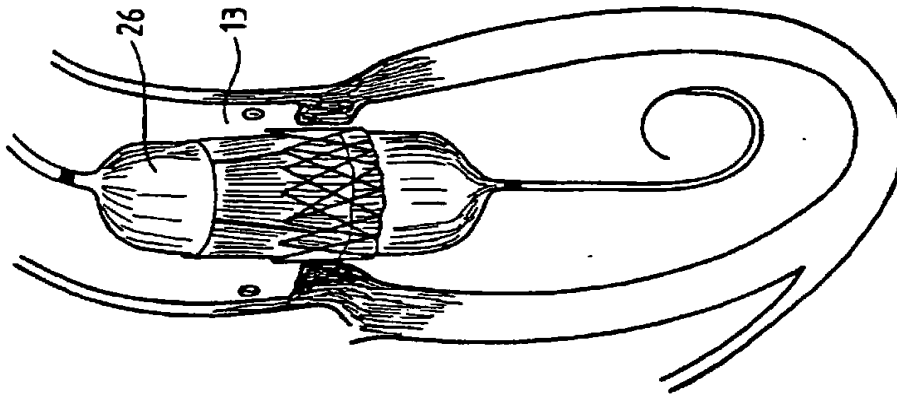


FIG-13h

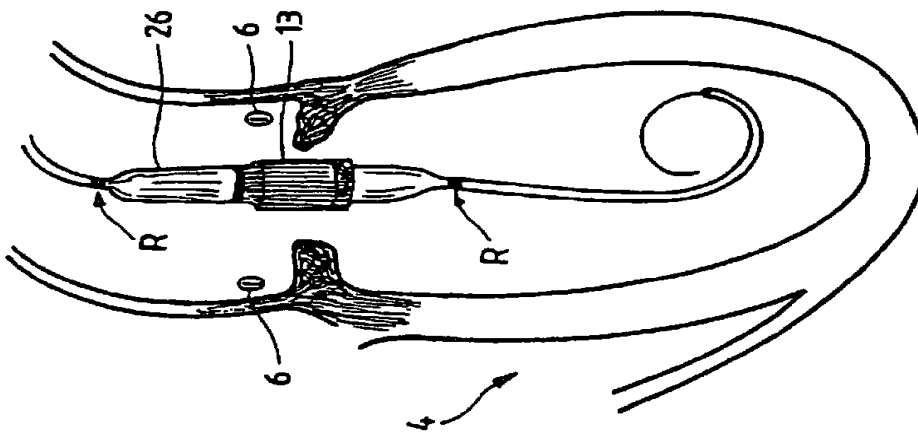


FIG-13g

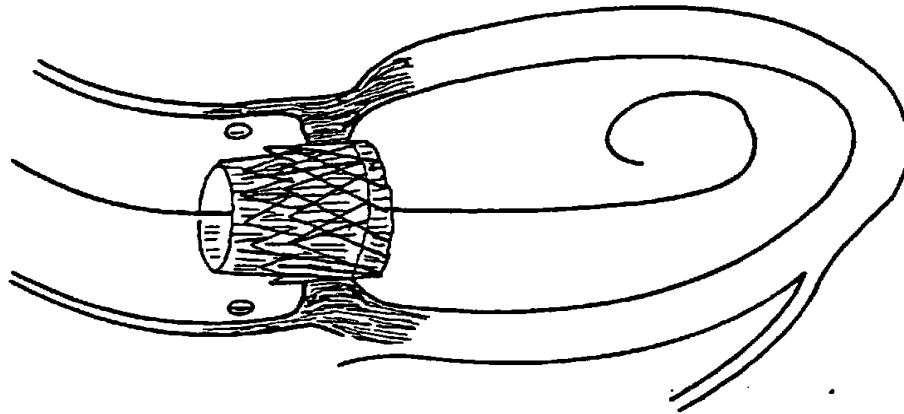


FIG-13l

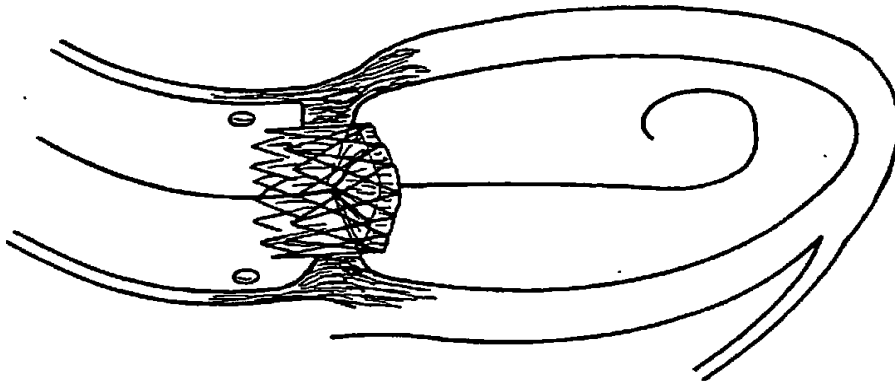


FIG-13k

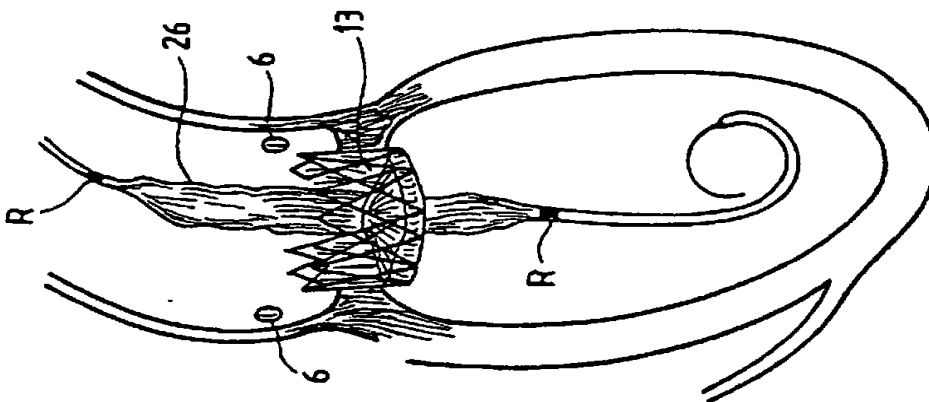
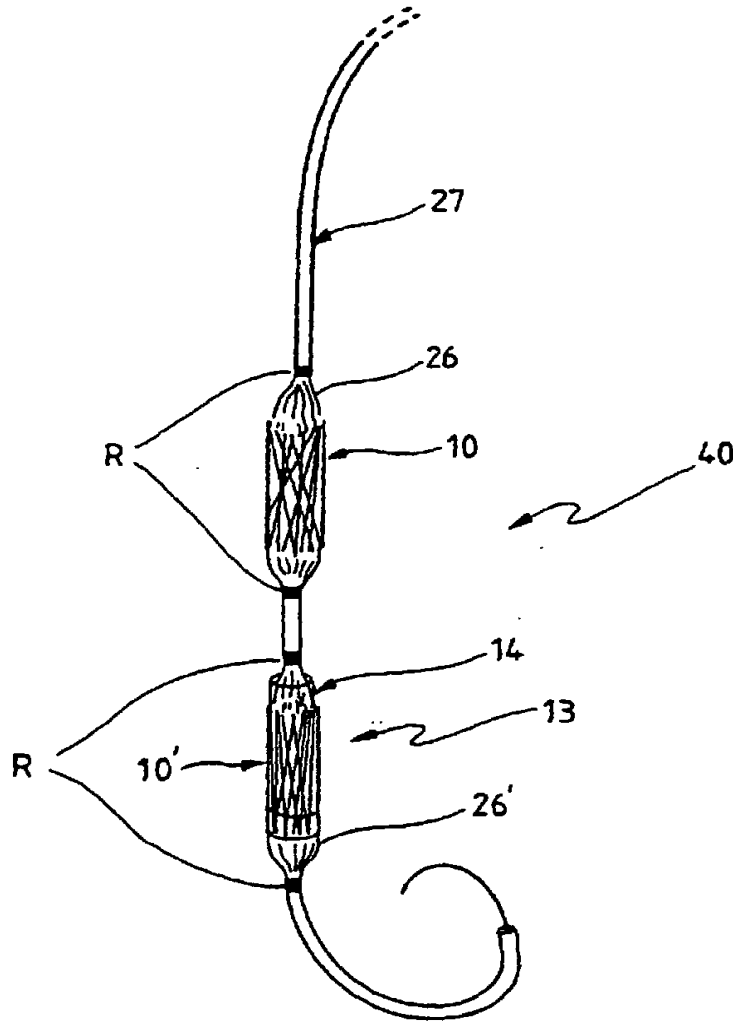
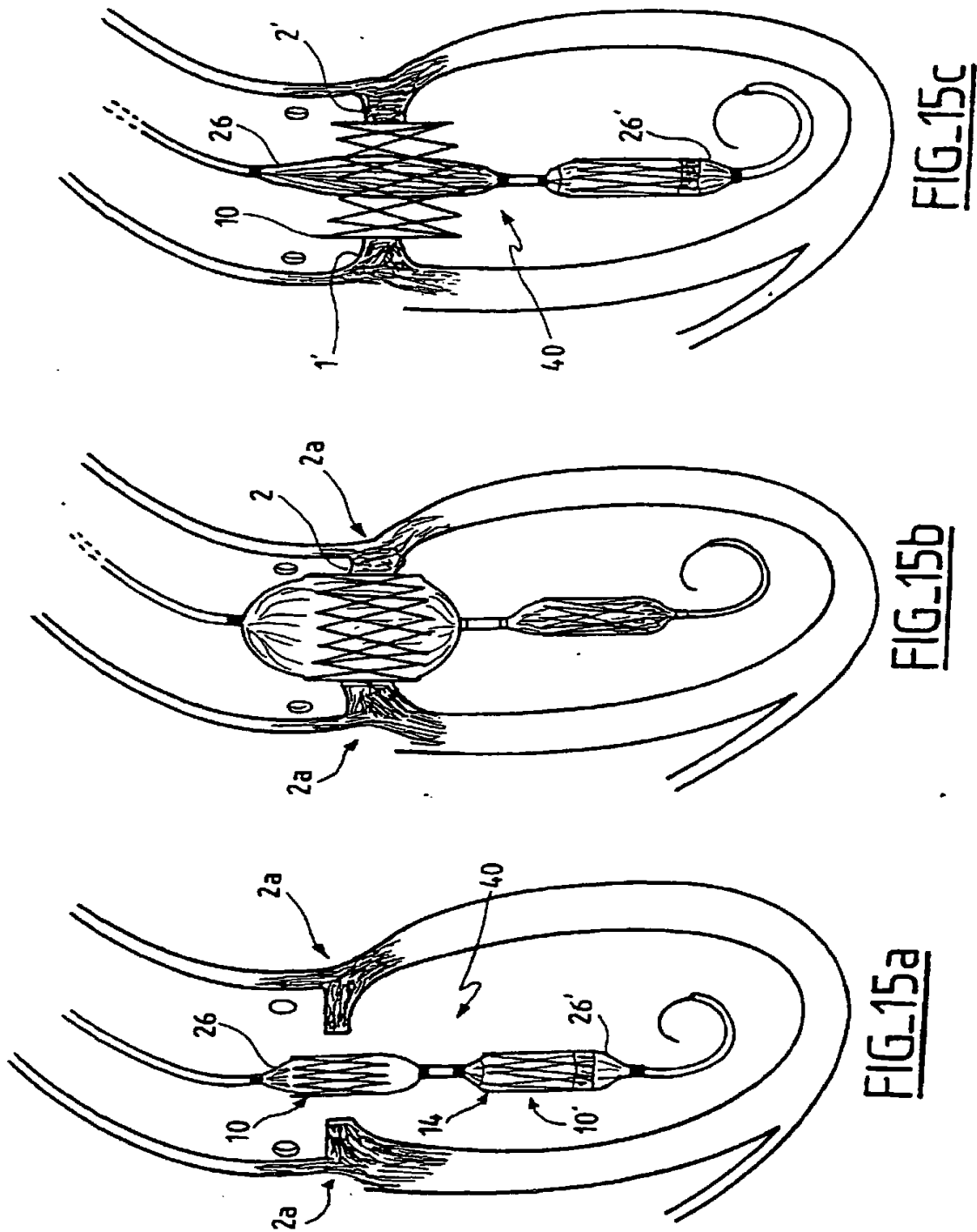


FIG-13j

FIG\_14





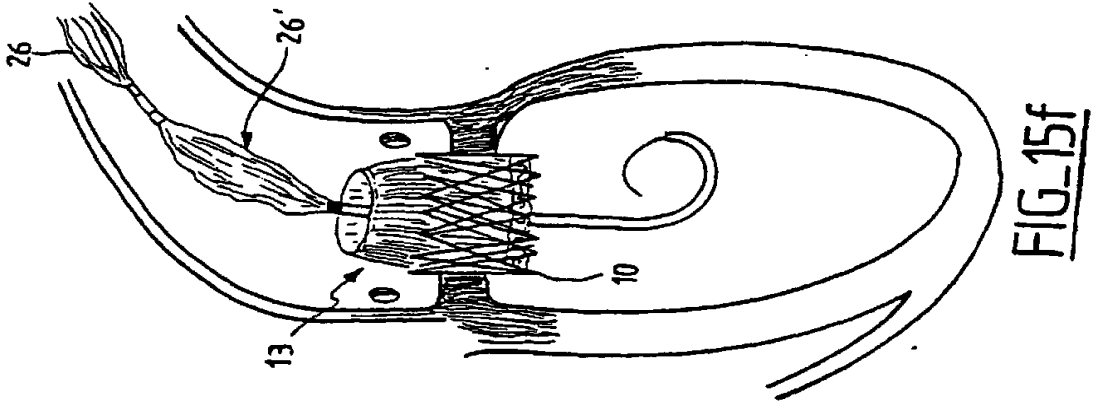


FIG-15f

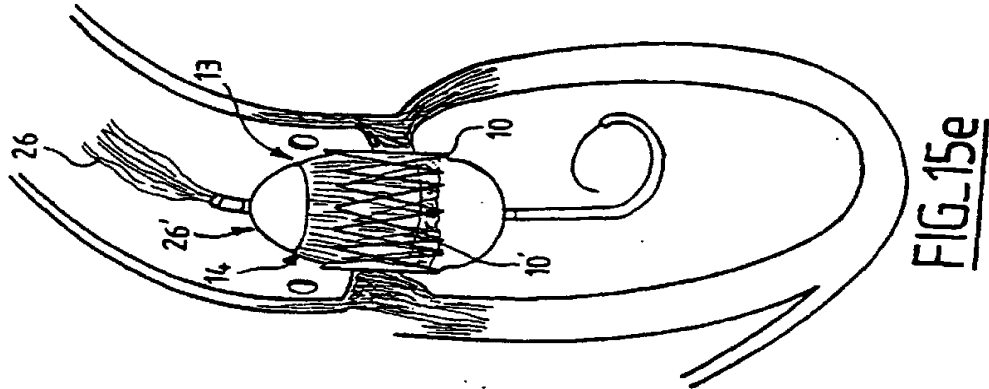


FIG-15e

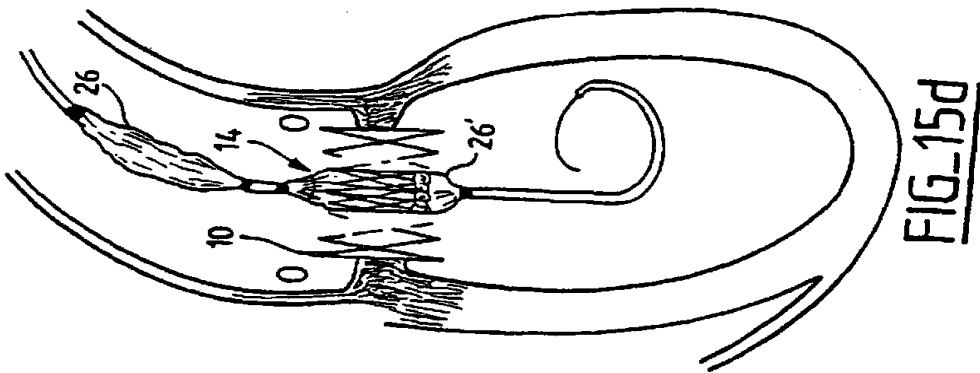


FIG-15d

**REFERENCES CITED IN THE DESCRIPTION**

*This list of references cited by the applicant is for the reader's convenience only. It does not form part of the European patent document. Even though great care has been taken in compiling the references, errors or omissions cannot be excluded and the EPO disclaims all liability in this regard.*

**Patent documents cited in the description**

- US 5411552 A [0014]
- WO 9412136 A [0024]
- US 5332402 A [0025]



(11) **EP 2 000 115 B8**

(12) **CORRECTED EUROPEAN PATENT SPECIFICATION**

(15) Correction information:  
**Corrected version no 1 (W1 B1)**  
**Corrections, see**  
**Bibliography INID code(s) 84**

(51) Int Cl.:  
**A61F 2/24<sup>(2006.01)</sup>** **B60K 37/06<sup>(2006.01)</sup>**

(48) Corrigendum issued on:  
**28.09.2011 Bulletin 2011/39**

(45) Date of publication and mention  
of the grant of the patent:  
**04.05.2011 Bulletin 2011/18**

(21) Application number: **08016624.2**

(22) Date of filing: **31.12.1997**

(54) **A prosthetic valve assembly**  
Herzklappenprothesenanordnung  
Ensemble de valve prothétique

(84) Designated Contracting States:  
**DE ES FR IT NL**

(30) Priority: **31.12.1996 EP 96402929**

(43) Date of publication of application:  
**10.12.2008 Bulletin 2008/50**

(60) Divisional application:  
**10012626.7 / 2 260 796**  
**10012627.5 / 2 260 797**  
**10012954.3 / 2 263 609**  
**10184036.1 / 2 260 798**

(62) Document number(s) of the earlier application(s) in  
accordance with Art. 76 EPC:  
**05024006.8 / 1 621 162**  
**97953935.0 / 0 967 939**

(73) Proprietor: **Edwards Lifesciences PVT, Inc.**  
**Irvine, CA 92614 (US)**

(72) Inventors:  
• **Letac, Brice**  
**deceased (FR)**  
• **Cribier, Alain**  
**76570 Pavilly (FR)**

(74) Representative: **Vaillant, Jeanne et al**  
**Ernest Gutmann - Yves Plasseraud S.A.S.**  
**3, rue Auber**  
**75009 Paris (FR)**

(56) References cited:  
**WO-A-93/01768** **WO-A-94/12136**  
**WO-A1-96/40008** **US-A- 3 548 417**  
**US-A- 3 657 744** **US-A- 4 629 459**  
**US-A- 4 692 164**

**EP 2 000 115 B8**

Note: Within nine months of the publication of the mention of the grant of the European patent in the European Patent Bulletin, any person may give notice to the European Patent Office of opposition to that patent, in accordance with the Implementing Regulations. Notice of opposition shall not be deemed to have been filed until the opposition fee has been paid. (Art. 99(1) European Patent Convention).



(11) **EP 2 000 115 B1**

(12) **EUROPEAN PATENT SPECIFICATION**

(45) Date of publication and mention of the grant of the patent:  
**04.05.2011 Bulletin 2011/18**

(51) Int Cl.:  
**A61F 2/24 (2006.01) B60K 37/06 (2006.01)**

(21) Application number: **08016624.2**

(22) Date of filing: **31.12.1997**

(54) **A prosthetic valve assembly**  
Herzklappenprothesenanordnung  
Ensemble de valve prothétique

(84) Designated Contracting States:  
**DE ES FR GB IT NL**

(73) Proprietor: **Edwards Lifesciences PVT, Inc.**  
**Irvine, CA 92614 (US)**

(30) Priority: **31.12.1996 EP 96402929**

(72) Inventors:  
• **Letac, Brice**  
**deceased (FR)**  
• **Cribier, Alain**  
**76570 Pavilly (FR)**

(43) Date of publication of application:  
**10.12.2008 Bulletin 2008/50**

(60) Divisional application:  
**10012626.7 / 2 260 796**  
**10012627.5 / 2 260 797**  
**10012954.3 / 2 263 609**  
**10184036.1 / 2 260 798**

(74) Representative: **Vaillant, Jeanne et al**  
**Ernest Gutmann - Yves Plasseraud S.A.S.**  
**3, rue Auber**  
**75009 Paris (FR)**

(62) Document number(s) of the earlier application(s) in accordance with Art. 76 EPC:  
**05024006.8 / 1 621 162**  
**97953935.0 / 0 967 939**

(56) References cited:  
**WO-A-93/01768 WO-A-94/12136**  
**WO-A1-96/40008 US-A- 3 548 417**  
**US-A- 3 657 744 US-A- 4 629 459**  
**US-A- 4 692 164**

**EP 2 000 115 B1**

Note: Within nine months of the publication of the mention of the grant of the European patent in the European Patent Bulletin, any person may give notice to the European Patent Office of opposition to that patent, in accordance with the Implementing Regulations. Notice of opposition shall not be deemed to have been filed until the opposition fee has been paid. (Art. 99(1) European Patent Convention).



## Description

**[0001]** The present invention relates to a prosthetic valve assembly for implantation in body channels, more particularly but not only to, cardiac valve prosthesis to be implanted by a transcatheterization technique.

**[0002]** The valve assembly or prosthesis can be also applied to other body channels provided with native valves, such as veins or in organs (liver, intestine, urethra,...).

**[0003]** The present description also discloses a method for implanting a valve prosthesis, such as the valve according to the present invention.

**[0004]** Implantable valves, which will be indifferently designated hereafter as "IV", "valve prosthesis" or "prosthetic valve", permits the reparation of a valvular defect by a less invasive technique in place of the usual surgical valve implantation which, in the case of valvular heart diseases, requires thoracotomy and extracorporeal circulation. A particular use for the IV concerns patients who cannot be operated on because of an associated disease or because of very old age or also patients who could be operated on but only at a very high risk.

**[0005]** Although the IV of the present invention and the process for implanting said IV can be used in various heart valve diseases, the following description will first concern the aortic orifice in aortic stenosis, more particularly in its degenerative form in elderly patients.

**[0006]** Aortic stenosis is a disease of the aortic valve in the left ventricle of the heart. The aortic valvular orifice is normally capable of opening during systole up to 4 to 6 cm<sup>2</sup>, therefore allowing free ejection of the ventricular blood volume into the aorta. This aortic valvular orifice can become tightly stenosed, and therefore the blood cannot anymore be freely ejected from the left ventricle. In fact, only a reduced amount of blood can be ejected by the left ventricle which has to markedly increase the intra-cavitary pressure to force the stenosed aortic orifice. In such aortic diseases, the patients can have syncope, chest pain, and mainly difficulty in breathing. The evolution of such a disease is disastrous when symptoms of cardiac failure appear, since 50 % of the patients die in the year following the first symptoms of the disease.

**[0007]** The only commonly available treatment is the replacement of the stenosed aortic valve by a prosthetic valve via surgery: this treatment moreover providing excellent results. If surgery is impossible to perform, i.e., if the patient is deemed inoperable or operable only at a too high surgical risk, an alternative possibility is to dilate the valve with a balloon catheter to enlarge the aortic orifice. Unfortunately, a good result is obtained only in about half of the cases and there is a high restenosis rate, i.e., about 80% after one year.

**[0008]** Aortic stenosis is a very common disease in people above seventy years old and occurs more and more frequently as the subject gets older. As evidenced, the present tendency of the general evolution of the pop-

ulation is becoming older and older. Also, it can be evaluated, as a crude estimation, that about 30 to 50% of the subjects who are older than 80 years and have a tight aortic stenosis, either cannot be operated on for aortic valve replacement with a reasonable surgical risk or even cannot be considered at all for surgery.

**[0009]** It can be estimated that, about 30 to 40 persons out of a million per year, could benefit from an implantable aortic valve positioned by a catheterization technique. Until now, the implantation of a valve prosthesis for the treatment of aortic stenosis is considered unrealistic to perform since it is deemed difficult to superpose another valve such an implantable valve on the distorted stenosed native valve without excising the latter.

**[0010]** From 1985, the technique of aortic valvuloplasty with a balloon catheter has been introduced for the treatment of subjects in whom surgery cannot be performed at all or which could be performed only with a prohibitive surgical risk. Despite the considerable deformation of the stenosed aortic valve, commonly with marked calcification, it is often possible to enlarge significantly the aortic orifice by balloon inflation, a procedure which is considered as low risk.

**[0011]** However, this technique has been abandoned by most physicians because of the very high restenosis rate which occurs in about 80% of the patients within 10 to 12 months. Indeed, immediately after deflation of the balloon, a strong recoil phenomenon often produces a loss of half or even two thirds of the opening area obtained by the inflated balloon. For instance, inflation of a 20 mm diameter balloon in a stenosed aortic orifice of 0.5 cm<sup>2</sup> area gives, when forcefully and fully inflated, an opening area equal to the cross sectional area of the maximally inflated balloon, i.e., about 3 cm<sup>2</sup>. However, measurements performed a few minutes after deflation and removal of the balloon have only an area around 1 cm<sup>2</sup> to 1.2 cm<sup>2</sup>. This is due to the considerable recoil of the fibrous tissue of the diseased valve. The drawback in this procedure has also been clearly shown on fresh post mortem specimens.

**[0012]** However, it is important to note that whereas the natural normal aortic valve is able to open with an orifice of about 5 to 6 cm<sup>2</sup> and to accommodate a blood flow of more than 15 l/min. during heavy exercise for instance, an opening area of about 1.5 to 2 cm<sup>2</sup> can accept a 6 to 8 l/min blood flow without a significant pressure gradient. Such a flow corresponds to the cardiac output of the elderly subject with limited physical activity.

**[0013]** Therefore, an IV would not have to produce a large opening of the aortic orifice since an opening about 2 cm<sup>2</sup> would be sufficient in most subjects, in particular in elderly subjects, whose cardiac output probably does not reach more than 6 to 8 l/min. during normal physical activity. For instance, the surgically implanted mechanical valves have an opening area which is far from the natural valve opening that ranges from 2 to 2.5 cm<sup>2</sup>, mainly because of the room taken by the large circular structure supporting the valvular part of the device.

**[0014]** The prior art describes examples of cardiac valves prosthesis that are aimed at being implanted without surgical intervention by way of catheterization. For instance, US patent n° 5,411,552 describes a collapsible valve able to be introduced in the body in a compressed presentation and expanded in the right position by balloon inflation.

**[0015]** Such valves, with a semi-lunar leaflet design, tend to imitate the natural valve. However, this type of design is inherently fragile, and such structures are not strong enough to be used in the case of aortic stenosis because of the strong recoil that will distort this weak structure and because they would not be able to resist the balloon inflation performed to position the implantable valve. Furthermore, this valvular structure is attached to a metallic frame of thin wires that will not be able to be tightly secured against the valve annulus. The metallic frame of this implantable valve is made of thin wires like in stents, which are implanted in vessels after balloon dilatation. Such a light stent structure is too weak to allow the implantable valve to be forcefully embedded into the aortic annulus. Moreover, there is a high risk of massive regurgitation (during the diastolic phase) through the spaces between the frame wires which is another prohibitive risk that would make this implantable valve impossible to use in clinical practice.

**[0016]** Furthermore, an important point in view of the development of the IV is that it is possible to maximally inflate a balloon placed inside the compressed implantable valve to expand it and insert it in the stenosed aortic valve up to about 20 to 23 mm in diameter. At the time of maximum balloon inflation, the balloon is absolutely stiff and cylindrical without any waist. At that moment, the implantable valve is squeezed and crushed between the strong aortic annulus and the rigid balloon with the risk of causing irreversible damage to the valvular structure of the implantable valve.

**[0017]** US-A-3,657,744 discloses a method for fixing prosthetic implants in a living body.

#### SUMMARY OF THE INVENTION

**[0018]** The invention is aimed to overcome these drawbacks and to implant an IV which will remain reliable for years.

**[0019]** A particular aim of the present invention is to provide an IV, especially aimed at being used in case of aortic stenosis, which structure is capable of resisting the powerful recoil force and to stand the forceful balloon inflation performed to deploy the IV and to embed it in the aortic annulus.

**[0020]** Another aim of the present invention is to provide an efficient prosthesis valve which can be implanted by a catheterization technique, in particular in a stenosed aortic orifice, taking advantage of the strong structure made of the distorted stenosed valve and of the large opening area produced by preliminary balloon inflation, performed as an initial step of the procedure.

**[0021]** A further aim of the present invention is to provide an implantable valve which would not produce any risk of fluid regurgitation.

**[0022]** A further aim of the present invention is to provide a valve prosthesis implantation technique using a two-balloon catheter and a two-frame device.

**[0023]** These aims are achieved according to the present invention which provides a prosthetic valve assembly according to claim 1.

**[0024]** The IV, which is strongly embedded, enables the implantable valve to be maintained in the right position without any risk of further displacement, which would be a catastrophic event.

**[0025]** More precisely, this valvular structure comprises a valvular tissue compatible with the human body and blood, which is supple and resistant to allow said valvular structure to pass from a closed state to an open state to allow a body fluid, more particularly the blood, exerting pressure on said valvular structure, to flow. The valvular tissue forms a continuous surface and is provided with guiding means formed or incorporated within, creating stiffened zones which induce the valvular structure to follow a patterned movement from its open position to its closed state and vice-versa, providing therefore a structure sufficiently rigid to prevent diversion, in particular into the left ventricle and thus preventing any regurgitation of blood into the left ventricle in case of aortic implantation.

**[0026]** Moreover, the guided structure of the IV allows the tissue of this structure to open and close with the same patterned movement while occupying as little space as possible in the closed state of the valve. Therefore, owing to these guiding means, the valvular structure withstands the unceasing movements under blood pressure changes during the heart beats.

**[0027]** More preferably, the valvular structure has a substantially truncated hyperboloidal shape in its expanded position, with a larger base and a growing closer neck, ending in a smaller extremity forming the upper part of the valvular structure. The valvular structure has a curvature at its surface that is concave towards the aortic wall. Such a shape produces a strong and efficient structure in view of the systolo-diastolic movement of the valvular tissue. Such a valvular structure with its simple and regular shape also lowers the risk of being damaged by forceful balloon inflation at the time of IV deployment.

**[0028]** A trunco-hyperboloidal shape with a small diameter at the upper extremity facilitates the closure of the valve at the beginning of diastole in initiating the starting of the reverse movement of the valvular tissue towards its base. Another advantage of this truncated hyperboloidal shape is that the upper extremity of the valvular structure, because of its smaller diameter, remains at a distance from the coronary ostia during systole as well as during diastole, thus offering an additional security to ensure not to impede at all the passage of blood from the aorta to the coronary ostia.

**[0029]** As another advantageous example, the guiding

means of the valvular structure are inclined strips from the base to the upper extremity of the valvular structure with regard to the central axis of the valvular structure. This inclination initiates and imparts a general helicoidal movement of the valvular structure around said central axis at the time of closure or opening of said structure, such a movement enabling to help initiate and finalize the closure of the valvular structure. In particular, this movement improves the collapse of the valvular structure towards its base at the time of diastole and during the reversal of flow at the very beginning of diastole. During diastole, the valvular structure thus falls down, folding on itself and collapses on its base, therefore closing the aortic orifice. The strips can be pleats, strengthening struts or thickened zones.

**[0030]** In other examples, said guiding means are rectilinear strips from the base to the upper extremity of the valvular structure. In this case, the guiding means can comprise pleats, struts or thickened zones. In a particular example, the stiffened zones then created can be advantageously two main portions, trapezoidal in shape, formed symmetrically one to each other with regard to the central axis of the valvular structure, and two less rigid portions separating said two main portions to lead to a tight closeness in shape of a closed slot at the time of closure of the upper extremities of the main portions of the valvular structure. The thickened zones can be extended up to form the stiffened zones.

**[0031]** More particularly, each of said main slightly rigid portions occupy approximately one third of the circumference of the valvular structure when this latter is in its open position. The slightly rigid portions maintain the valvular structure closed during diastole by firmly applying themselves on each other. The closure of the valvular structure at the time of diastole thus does not have any tendency to collapse too much towards the aortic annulus.

**[0032]** Preferably, the guiding means are a number of pleats formed within the tissue by folding, or formed by recesses or grooves made in the tissue. The shape of the pleats is adapted to achieve a global shape of the desired type for said position.

**[0033]** Alternatively, the guiding means are made of strengthening struts, preferably at least three, incorporated in the tissue in combination or not with said pleats.

**[0034]** The guiding means and, in particular, the strengthening struts, help to prevent the valvular tissue from collapsing back too much and to reverse inside the left ventricle through the base of the frame, preventing the risk of blood regurgitation.

**[0035]** Said valvular tissue is made of pericardium. These materials are commonly used in cardiac surgery and are quite resistant, particularly to folding movements due to the increasing systolo-diastolic movements of the valvular tissue and particularly at the junction with the frame of the implantable valve.

**[0036]** The valvular structure is fastened along a substantial portion of an expandable frame, by sewing, to

exhibit a tightness sufficiently hermetical to prevent any regurgitation of said body fluid between the frame and the valvular structure.

**[0037]** Preferably, an internal cover is coupled or is integral to the valvular structure and placed between said valvular structure and the internal wall of the frame to prevent any passage of the body fluid through said frame. Therefore, there is no regurgitation of blood as it would be the case if there were any space between the valvular structure fastened on the frame and the zone of application of the frame on the aortic annulus. The internal cover makes a sort of "sleeve" below the fastening of the valvular structure covering the internal surface of the frame and thus prevents any regurgitation of blood through the frame.

**[0038]** In the present invention, the frame is a substantially cylindrical structure capable of maintaining said body channel open in its expanded state and supporting said collapsible valvular structure.

**[0039]** In a preferred embodiment of the invention, the frame is made of a material which is distinguishable from biological tissue to be easily visible by non invasive imaging techniques.

**[0040]** Preferably, said frame is a stainless metal structure, made of intercrossing, preferably with rounded and smooth linear bars. This frame is strong enough to resist the recoil phenomenon of the fibrous tissue of the diseased valve. The size of the bars and their number are determined to give both the maximal rigidity when said frame is expanded and the smallest volume when the frame is compressed.

**[0041]** More preferably, the frame has projecting curved extremities and presents a concave shape. This is aimed at reinforcing the embedding and the locking of the implantable valve in the distorted aortic orifice.

**[0042]** In an example, the IV is made in two parts, a first reinforced frame coupled with a second frame which is made of thinner bars than said first frame and which is embedded inside the second frame. This second frame to which the valvular structure is fastened as described above, is preferably less bulky than the first frame to occupy as little space as possible and to be easily expanded using low pressure balloon inflation.

**[0043]** The present description also discloses a double balloon catheter to separately position the first frame in the dilated stenosed aortic valve and place the second frame that comprises the valvular structure. This catheter comprises two balloons fixed on a catheter shaft and separated by few centimeters.

**[0044]** The first balloon is of the type sufficiently strong to avoid bursting even at a very high pressure inflation and is aimed at carrying, in its deflated state, a strong frame aimed at scaffolding the previously dilated stenosed aortic valve. The second balloon is aimed at carrying the second frame with the valvular structure.

**[0045]** An advantage of this double balloon catheter is that each balloon has an external diameter which is smaller than known balloons since each element to be ex-

panded is smaller.

**[0046]** Moreover, such a double balloon catheter allows to enlarge the choice for making an efficient valvular structure enabling to overcome the following two contradictory conditions:

- 1) having a soft and mobile valvular structure capable of opening and closing freely in the blood stream, without risk of being damaged by balloon inflation; and
- 2) needing a very strong structure able to resist the recoil force of the stenosed valve and capable of resisting, without any damage, a strong pressure inflation of the expanding balloon.

**[0047]** Furthermore, the shaft of said double balloon catheter comprises two lumens for successive and separate inflation of each balloon. Of note, an additional lumen capable of allowing a rapid inflation takes additional room in the shaft.

**[0048]** The description also discloses a method of using a two-balloon catheter with a first frame and second frame to which a valve prosthesis of the type previously described is fastened.

#### DESCRIPTION OF THE DRAWINGS

**[0049]** The invention will now be explained and other advantages and features will appear with reference to the accompanying schematical drawings wherein :

- Figures 1a, 1b and 1c illustrate, in section views, respectively, the normal aortic valve in systole, in diastole and a stenosed aortic valve;
- Figures 2a and 2b illustrate two examples of a metallic frame which are combined to a valvular structure;
- Figures 3a and 3b illustrate a frame according to the invention in its expanded position with an opening out of the extremities, respectively, with a cylindrical and a concave shape;
- Figures 4a and b illustrate an IV of the invention respectively in its compressed position and in its expanded position in an open position as in systole;
- Figures 5a and 5b illustrate respectively an IV of the invention in its closed position and a sectional view according to the central axis of such a valvular structure which is closed as in diastole;
- Figures 6a to 6d illustrate a sectional view according to the central axis of an IV and showing the internal cover and the external cover of the valvular structure overlapping partially or non overlapping the frame bars;
- Figure 7 illustrates the frontal zig-zag fastening line of the valvular tissue on the frame;
- Figures 8a and 8b illustrate, respectively, a perspective view of a valvular structure and an internal cover made all of one piece and a perspective view of the

corresponding frame into which they will be inserted and fastened;

- Figures 9a and 9b illustrate inclined strengthening struts, an example of a valvular structure according to the invention, respectively in the open position and in the closed position;
- Figures 10a and 10b illustrate an example of a valvular structure comprising pleats, respectively in the open and in the closed position;
- Figures 11 a and 11 b illustrate a valvular structure comprising two trapezoidal slightly rigid portions, respectively in the open and in the closed position;
- Figures 11c to 11e illustrate a valvular structure comprising a rectangular stiffened zone, respectively in the open, intermediate and closed position;
- Figures 12a and 12b illustrate, respectively, a perspective and cross sectional views of an implantable valve in its compressed presentation squeezed on a balloon catheter;
- Figures 13a to 13f illustrate views of the successive procedure steps for the IV implantation in a stenosed aortic orifice;
- Figure 14 illustrate an implantable valve made in two parts in its compressed presentation squeezed on a two-balloon catheter with a reinforced frame on a first balloon and with the implantable valve on the second balloon; and
- Figures 15a to 15f illustrate the successive steps of the implantation of the implantation valve in two parts with a two-balloon catheter;

#### DETAILED DESCRIPTION OF THE PREFERRED EMBODIMENTS

**[0050]** In the diastole and systole illustrations of section views of Figures 1 a and 1b, the arrows A indicates the general direction of the blood flow. The semi-lunar leaflets 1 and 2 of a native aortic valve (with only two out of three shown here) are thin, supple and move easily from the completely open position (systole) to the closed position (diastole). The leaflets originate from an aortic annulus 2a.

**[0051]** The leaflets 1' and 2' of a stenosed valve as illustrated in Figure 1c, are thickened, distorted, calcified and more or less fused, leaving only a small hole or a narrow slit 3, which makes the ejection of blood from the left ventricle cavity 4 into the aorta 5 difficult and limited. Figures 1 a to 1 c show also the coronary artery ostium 6a and 6b and Figure 1 a shows, in particular, the mitral valve 7 of the left ventricle cavity 4.

**[0052]** An implantable valve according to the invention essentially comprises a supple valvular structure supported by a strong frame. The positioning of the implantable valve is an important point since the expanded frame has to be positioned exactly at the level of the native valvular leaflets 1, 2 of the native valve, the structures of which are pushed aside by the inflated balloon.

**[0053]** Ideally, the implantable valve is positioned with

the fastening line of the valvular structure on the frame exactly on the remains of the crushed stenosed valve to prevent any regurgitation of blood. In practice, it is difficult to position the implantable valve within less than 2 or 3 mm. However, any risk of regurgitation of blood is eliminated with the presence of an internal cover, as will be described below.

**[0054]** The upper limit of the frame should be placed below the opening of the coronary arteries, i.e., the coronary ostia 6, or at their level so that the frame does not impede free blood flow in the coronary arteries. This point is a delicate part of positioning an IV since the distance between the superior limit of the leaflets of the natural valve and the coronary ostia 6 is only about 5 to 6 mm. However, the ostia are located in the Valsalva sinus 8 which constitutes a hollow that are located a little out of the way. This helps to prevent from impeding the coronary blood flow by the IV.

**[0055]** At the time of implantation, the operator evaluates the exact positioning of the coronary ostia by looking at the image produced by a sus-valvular angiogram with contrast injection performed before the implantation procedure. This image will be fixed in the same projection on a satellite TV screen and will permit the evaluation of the level of the origin of the right and left coronary arteries. Possibly, in case the ostia are not clearly seen by sus-valvular angiography, a thin guide wire, as those used in coronary angioplasty, is positioned in each of the coronary arteries to serve as a marker of the coronary ostia.

**[0056]** The lower part of the frame of the IV preferably extends by 2 or 3 mm inside the left ventricle 4, below the aortic annulus 2a. However, this part of the frame should not reach the insertion of the septal leaflet of the mitral valve 7, so that it does not interfere with its movements, particularly during diastole.

**[0057]** Figures 2a and 2b show respectively an example of a cylindrical frame 10 comprising intercrossing linear bars 11, with two intersections I by bar 11, the bars 11 being soldered or provided from a folded wire to constitute the frame, with for instance a 20 mm, 15 mm or 12 mm height, and an example with only one intersection of bars 11. Preferably, such a frame is expandable from a size of about 4 to 5 millimeters to a size of about 20 to 25 mm in diameter, or even to about 30-35 mm (or more) in particular cases, for instance for the mitral valve. Moreover, said frame, in its fully expanded state, has a height of approximately between 10 and 15 mm and in its fully compressed frame, a height of approximately 20 mm. The number and the size of the bars are adapted to be sufficiently strong and rigid when the frame is fully open in the aortic orifice to resist the strong recoil force exerted by the distorted stenosed aortic orifice after deflation of the balloon used in the catheterization technique which has been previously maximally inflated to enlarge the stenosed valve orifice;

**[0058]** The frame may have several configurations according to the number of bars 11 and intersections. This number, as well as the size and the strength of the bars

11, are calculated taking into account all the requirements described, i.e., a small size in its compressed form, its capacity to be enlarged up to at least 20 mm in diameter and being strong when positioned in the aortic orifice to be able to be forcefully embedded in the remains of the diseased aortic valve and to resist the recoil force of the aortic annulus. The diameter of the bars is chosen, for instance, in the range of 0.1-0.6 mm.

**[0059]** A frame particularly advantageous presents, when deployed in its expanded state, an opening out 12 at both extremities as shown in Figures 3a and 3b, the frame having a linear profile (Figure 3a not part of invention) or a concave shape profile (Figure 3b). This is aimed at reinforcing the embedding of the IV in the aortic orifice. However, the free extremities of the openings 12 are rounded and very smooth to avoid any traumatism of the aorta or of the myocardium.

**[0060]** The structure of a preferred frame used in the present invention both maintains the aortic orifice fully open once dilated and produces a support for the valvular structure. The frame is also foldable. When folded by compression, the diameter of said frame is about 4 to 5 millimeters, in view of its transcatheter introduction in the femoral artery through an arterial sheath of 14 to 16 F (F means French, a unit usually used in cardiology field) i.e., about 4.5 to 5.1 mm. Also, as described below, when positioned in the aortic orifice, the frame is able to expand under the force of an inflated balloon up to a size of 20 to 23 mm in diameter.

**[0061]** The frame is preferably a metallic frame, preferably made of steel. It constitutes a frame with a grate type design able to support the valvular structure and to behave as a strong scaffold for the open stenosed aortic orifice.

**[0062]** When the frame is fully expanded, its intercrossing bars push against the remains of the native stenosed valve that has been crushed aside against the aortic annulus by the inflated balloon. This produces a penetration and embeds the bars within the remains of the stenosed valve, in particular owing to a concave profile of the frame provided with an opening out, as illustrated in Figure 3b. This embedding of the frame on the aortic annulus, or more precisely on the remains of the crushed distorted aortic valve, will be determinant for the strong fixation of the IV in the right position, without any risk of displacement.

**[0063]** Moreover, the fact that the valve leaflets in degenerative aortic stenosis are grossly distorted and calcified, sometimes leaving only a small hole or a small slit in the middle of the orifice, has to be considered an advantage for the implantation of the valve and for its stable positioning without risk of later mobilization. The fibrous and calcified structure of the distorted valve provides a strong base for the frame of the IV and the powerful recoil phenomenon that results from elasticity of the tissues contribute to the fixation of the metallic frame.

**[0064]** The height of the fully expanded frame of the illustrated frames 10 is preferably between 10 and 15

mm. Indeed, since the passage from the compressed state to the expanded state results in a shortening of the metallic structure, the structure in its compressed form is a little longer, i.e., preferably about 20 mm length. This does not constitute a drawback for its transcutaneous introduction and its positioning in the aortic orifice.

**[0065]** As mentioned above, the frame is strong enough to be able to oppose the powerful recoil force of the distended valve and of the aortic annulus 2a. Preferably it does not possess any flexible properties. When the frame has reached its maximal expanded shape under the push of a forcefully inflated balloon, it remains substantially without any decrease in size and without any change of shape. The size of the bars that are the basic elements of the frame is calculated in such a way to provide a substantial rigidity when the frame is fully expanded. The size of the bars and their number are calculated to give both maximal rigidity when expanded and the smallest volume when the metallic frame is its compressed position.

**[0066]** At the time of making the IV, the frame is expanded by dilatation to its broadest dimension, i.e., between 20 mm and 25 mm in diameter, so as to be able to fasten the valvular structure on the inside side of its surface. This fastening is performed using the techniques in current use for the making of products such as other prosthetic heart valves or multipolars catheters etc. Afterwards, it is compressed in its minimal size, i.e., 4 or 5 mm, in diameter in view of its introduction in the femoral artery. At time of the IV positioning, the frame is expanded again by balloon inflation to its maximal size in the aortic orifice.

**[0067]** If the frame is built in an expanded position, it will be compressed, after fastening the valvular structure, by exerting a circular force on its periphery and/or on its total height until obtaining the smallest compressed position. If the frame is built in its compressed position, it will be first dilated, for instance, by inflation of a balloon and then compressed again as described above.

**[0068]** To help localizing the IV, the frame being the only visible component of the valve, the shaft of the balloon catheter on which will be mounted the IV before introduction in the body (see below) possesses preferentially metallic reference marks easily seen on fluoroscopy. One mark will be at level of the upper border of the frame and the other at the level of the lower border. The IV, when mounted on the catheter shaft and crimped on it, is exactly positioned taking into account these reference marks on the shaft.

**[0069]** Accordingly, the frame is visible during fluoroscopy when introduced in the patient's body. When the frame is positioned at the level of the aortic annulus, the upper border of the frame is placed below the coronary ostia. Furthermore, the implanting process during which the balloon inflation completely obstructs the aortic orifice, as seen below, is performed within a very short time, i.e., around 10 to 15 seconds. This also explains why the frame is clearly and easily seen, without spending time

to localize it. More particularly, its upper and lower borders are clearly delineated.

**[0070]** Figures 4a and 4b show an example of a preferred IV 13 of the present invention, respectively in its compressed position, in view of its introduction and positioning in the aortic orifice, and in its expanded and opened (systole) position. Figures 5a and 5b show the expanded position of this example closed in diastole, respectively in perspective and in a crossed section view along the central axis X'X of the valve prosthesis.

**[0071]** The valvular structure 14 is compressed inside the frame 10 when this is in its compressed position (Figure 4a), i.e., it fits into a 4 to 5 mm diameter space. On the other hand, the valvular structure can expand (Figure 4b) and follow the frame expansion produced by the inflated balloon. It will have to be able to reach the size of the inside of the fully deployed frame.

**[0072]** The illustrated IV 13 is made of a combination of two main parts:

- 1) the expandible but substantially rigid structure made of the frame 10, a metallic frame in the example; and
- 2) a soft and mobile tissue constituting the valvular structure 14 exhibiting a continuous surface truncated between a base 15 and an upper extremity 16; the tissue is fastened to the bars 11 of the frame at its base 15 and is able to open in systole and to close in diastole at its extremity 16, as the blood flows in a pulsatile way from the left ventricle towards the aorta.

**[0073]** The tissue has rectilinear struts 17 incorporated in it in plane including the central axis X'X, in order to strengthen it, in particular, in its closed state with a minimal occupation of the space, and to induce a patterned movement between its open and closed state. Other examples of strengthening struts are described below. They are formed from thicker zones of the tissue or from strips of stiffening material incorporated in the tissue; they can also be beveled or soldered on the valvular tissue.

**[0074]** These strengthening struts help to prevent the valvular tissue from collapsing back too much and to evert inside the left ventricle through the base of the frame. These reinforcements of the valvular tissue help maintain the folded tissue above the level of the orifice during diastole, prevent too much folding back and risk of inversion of the valvular structure inside the left ventricle. By also preventing too much folding, a decrease of the risk of thrombi formation can also be expected by reducing the number of folds.

**[0075]** The truncated shape forming a continuous surface enables to obtain a strong structure and is more efficient for the systolo-diastolic movements of the valvular tissue during heart beats. The truncoïdal shape facilitates the closure of the valve structure at the beginning of diastole in facilitating the start of the reverse movement of the valvular tissue towards its base at the time of di-

astole, i.e., at the time of flow reversal at the very beginning of diastole. During diastole, the valvular structure 14 thus falls down, folding on itself, thereby collapsing on its base, and therefore closing the aortic orifice. In fact, the valvular structure has preferably, as illustrated,

**[0076]** Moreover, the basis of the truncated hyperboloid is fixed on the lower part of a frame and the smallest extremity of the truncated hyperboloid is free in the blood stream, during the respected closing and opening phasis.

**[0077]** An important advantage of this hyperboloidal shape is that the upper extremity 16 of the valvular structure 14 can remain at a distance from the coronary ostia during systole as well as during diastole, because of its smaller diameter, thus offering an additional security to make certain that the passage of blood from aorta to the coronary ostia is not impeded.

**[0078]** The base 15 of the truncated tissue is attached on the frame 10 along a line of coupling 18 disposed between the inferior fourth and the third fourth of the frame in the example. The upper extremity 16, with the smaller diameter, overpasses the upper part of the frame by a few millimeters; 6 to 8 mm, for instance. This gives the valvular structure a total height of about 12 to 15 mm.

**[0079]** The upper extremity 16 of the truncated tissue, i.e., the smaller diameter of the hyperboloidal structure 14, is about 17 to 18 mm in diameter (producing a 2.3 to 2.5 cm<sup>2</sup> area opening) for a 20 mm diameter base of the truncated structure, or 19 to 20 mm in diameter (producing a 2.8 or a 3 cm<sup>2</sup> area opening) for a 23 mm diameter base. An opening area around 2 cm<sup>2</sup> or slightly above, gives satisfactory results, particularly in elderly patients who would not reasonably need to exert high cardiac output.

**[0080]** For instance, in the present example, the line of fastening of the base of the truncated tissue on the frame will have to expand from a 12.5 mm perimeter (for a 4 mm external diameter of the compressed IV) to a 63 mm perimeter ( for a 20 mm external diameter of the expanded IV ), or to a 72 mm perimeter (for a 23 mm external diameter, in case a 23 mm balloon is used).

**[0081]** Another advantage of this truncated continuous shape is that it is stronger and has less risk of being destroyed or distorted by the forceful balloon inflation at the time of IV deployment. Also, if the truncated hyperboloidal shape is marked, for instance, with a 16 or 17 mm diameter of the upper extremity as compared to a 20 mm diameter of the base (or 18 to 20 mm for 23 mm), the smaller upper part is compliant during balloon inflation in order to enable the balloon to expand cylindrically to its maximal 20 mm diameter (or 23 mm). This is made possible by using a material with some elastic or compliant properties.

**[0082]** The valvular structure of the invention, as shown in the illustrated example, includes advantageously a third part, i.e., the internal cover 19 to be fixed

on the internal wall of the frame 10. This internal cover prevents any passage of blood through the spaces between the bars 11 of the frame in case the implantable valve would be positioned with the fastening line of the valvular structure on the frame not exactly on the remains of the dilated aortic valve, i.e., either above or below. It also strengthens the fastening of the valvular structure 14 to the frame 10.

**[0083]** In the different sectional views of the different examples of IV, as illustrated at Figures 6a to 6c, the internal cover 19 covers the totality of the internal side of the frame 10 (Figure 6a), only the lower part of the frame 10 according to the invention (figure 6b), or it can additionally cover partially 3 to 5 mm as shown in the passage of blood from aorta to the coronary ostia Figure 6c, the upper part defined above the coupling line 18 of the valvular structure.

**[0084]** For instance, such an extension of the internal cover 19 above the fastening line 18 of the valvular structure will give another security to avoid any risk of regurgitation through the spaces between the bars 11 in case the IV would be positioned too low with respect to the border of the native aortic valve.

**[0085]** The internal cover can also be molded to the valvular structure or casted to it which therefore constitutes an integral structure. The valvular structure and the internal cover are therefore strongly locked together with minimum risk of detachment of the valvular structure which is unceasingly in motion during systole and diastole. In that case, only the internal cover has to be fastened on the internal surface of the frame which renders the making of the IV easier and makes the complete device stronger and more resistant. In particular, the junction of the mobile part of the valvular structure and the fixed part being molded as one piece is stronger and capable to face the increasing movements during the systolo-diastolic displacements without any risk of detachment.

**[0086]** The presence of the internal cover makes an additional layer of plastic material that occupies the inside of the frame and increases the final size of the IV. Therefore, in the case in which the internal cover is limited to the inferior part of the frame (that is, below the fastening line of the valvular structure), it does not occupy any additional space inside the frame. Here also, it is more convenient and safer to make the valvular structure and this limited internal cover in one piece.

**[0087]** In other aspects, to prevent any regurgitation of blood from the aorta towards the left ventricle during diastole, the base of the valvular structure is preferably positioned exactly at the level of the aortic annulus against the remains of distorted stenosed valve pushed apart by the inflated balloon. Therefore, there is no possibility of blood passage through the spaces between the metallic frame bars 11 below the attachment of the valvular structure.

**[0088]** However, to avoid any risk of leaks, the part of the frame below the fastening of the valvular structure

(about 3 to 5 mm) is preferably covered by an internal cover which is made with the same tissue as the valvular structure. Thus, there would be no regurgitation of blood which is a possibility when there is any space between the valvular structure fastened on the metallic frame and the line of application of the frame on the aortic annulus. The internal cover makes a sort of "sleeve" below the fastening of the valvular structure on the internal surface of the frame, covering the spaces between the frame bars of the frame at this level, thus preventing any regurgitation of blood through these spaces.

**[0089]** The internal cover can also have another function, i.e., it can be used to fasten the valvular structure inside the frame, as described below.

**[0090]** At Figure 6d, the internal cover 19 is extended at its lower end 19' to an external cover 19" which is rolled up to be applied on the external wall of the stent 10. The internal and external cover are molded, glued or soldered to the bars of the stent 10.

**[0091]** The coupling process of the valvular structure on the frame is of importance since it has to be very strong without any risk of detachment of the valvular structure from the frame during millions of heart beats with pulsatile blood flow alternatively opening and closing the valvular structure.

**[0092]** The valvular structure of the invention folds to a very small size inside the frame in the compressed position of the valve and is expandable up to 20 to 23 mm diameter. Also, the valvular structure can resist the strong force exerted by the maximally inflated balloon that will powerfully squeeze it against the bars of the frame or against the internal cover, this one being squeezed directly against the bars of the frame. The junction zone is also particularly subjected to very strong pressure exerted by the inflated balloon. Furthermore, this junction zone must not tear or break off during expansion of the balloon. At this time, each part of the junction zone is squeezed against the bars but nonetheless follows the expansion of the frame.

**[0093]** As shown in Figure 7, the junction zone is, for example, a fastening line 20 which follows the design of a "zig-zag" line drawn by the intercrossing bars 11 of the frame on the internal cover 19.

**[0094]** The fastening of the valvular structure to the frame can be made by sewing the internal and/or the external cover to the bars. To prevent any leakage of blood, stitches are preferably numerous and very close to each other, either as separated stitches or as a continuous suture line. Also, the stitches are made directly around the bars 11. Furthermore, since the valvular structure is expanded together with the metallic frame, the stitches, if made as a continuous suture line, are also able to expand at the same time.

**[0095]** According to an example, the fastening process can also be made by molding the base of the valvular structure on the frame. At this level, the bars 11 are imbedded in the coupling line of the valvular structure 14. This mold way also concerns the internal cover 19, when

it goes below the coupling line 14 on the frame over few millimeters, for example, 2 to 4 mm. As mentioned above, this is intended in order to prevent any regurgitation of blood just below the lower part of the valvular structure 14 in case the frame 10 would not be exactly positioned on the aortic annulus but at few millimeters away.

**[0096]** The fastening process as examples can further be made by gluing or soldering the valvular structure on the bars with sufficiently powerful biocompatible glues. The same remark can be made concerning the internal cover of the frame below the coupling line of the valvular structure.

**[0097]** Also, this allows the coupling line to follow the frame changes from the compressed position to its expanded one.

**[0098]** The valvular structure can also be fastened on the internal cover previously fixed at the total length of the internal surface of the metallic frame. The internal cover constitutes therefore a surface on which any type of valvular structure be more easily sewed, molded or glued. Because it is a structure with a large surface and is not involved in the movements of the valvular tissue during systole and diastole, the internal cover is more easily fastened to the internal surface of the frame.

**[0099]** In the particular embodiment shown in Figure 8, the internal cover 19 is fastened, after introduction (indicated by the arrow B), at the upper and lower extremities of the frame 10 on the upper and lower zig-zag lines of the intercrossing bars 11. In fact, the fastening of the internal cover 19 on the zig-zag lines made by the intercrossing bars 11 of the frame allows an easier passage of blood from the aorta above the IV towards the coronary ostia. Indeed, the blood can find more space to flow into the coronary ostia by passing through the lowest point of each triangular space made by two intercrossing bars 11, as indicated by the arrows A1 (see also Figure 1b).

**[0100]** The fastening of the internal cover 19 on the extremities can be reinforced by various points of attachment on various parts of the internal surface of the frame 10. The internal cover 27 is fastened by sewing, the bars 11 onto the frame.

**[0101]** Fastening the valvular tissue (and the cover tissue below) on the inside of the frame, requires work on the frame in its expanded position to have access to the inside of this cylindric frame. In a preferred example the frame is expanded a first time for fastening the valvular tissue on its bars, then compressed back to a smaller size to be able to be introduced via arterial introducer and finally expanded again by the balloon inflation.

**[0102]** Since it is aimed at being positioned in the heart after having been introduced by a catheterization technique by a transcutaneous route in a peripheral artery, mainly the femoral artery, the IV should preferably have the smallest possible external diameter. Ideally, it should be able to be introduced in the femoral artery through a 14 F (4,5 mm) size arterial introducer which is the size of the arterial introducer commonly used to perform an aortic dilatation. However, a 16 F (5,1 mm) or even a 18



F (5,7 mm) introducer would also be acceptable.

**[0103]** Above this size, the introduction of the IV in the femoral artery should probably be done by a surgical technique. This is still quite acceptable since the surgical procedure would be a very light procedure which could be done by a surgeon with a simple local anaesthesia. It has to be recalled that this technique is used to position big metallic frames, about 24 F in size (7.64 mm in diameter), in the abdominal aorta for the treatment of aneurysms of the abdominal aorta. In that situation, this necessitates surgical repair of the artery after withdrawal of the sheath (M. D. Dake, New Engl. J Med. 1994;331: 1729-34).

**[0104]** Ideally, an IV should be able to last several tenths of life years without defect, like the mechanical prosthetic valves which are currently implanted by the surgeons. Nevertheless, an implantable valve that would last at least ten years without risk of deterioration would be effective for the treatment of elderly patients.

**[0105]** A valvular structure according to the invention is made of a supple and reinforced tissue which has a thickness to be thin enough to occupy as less as possible space in the compressed form of the valve, is pliable, and also strong enough to stand the unceasing movements under the blood pressure changes during heart beats. The valvular structure is capable of moving from its closed position to its open position under the action of the force exerted by the movements of the blood during systole and diastole, without having any significant resistance to blood displacements.

**[0106]** The material used for the tissue, which exhibits the above mentioned requirements, may be Teflon® or Dacron®, which are quite resistant to folding movements, at least when they are used to repair cardiac defects such as inter-atrial or interventricular defects or when they are used to repair a valve such as the mitral valve which is subjected to high pressure changes and movements during heart beats. Also, a main point is the increasing systolo-diastolic movements of the valvular tissue, particularly at its junction with the rigid part of the IV, and it is therefore necessary to find the most possible resistant material tissue.

**[0107]** As mentioned previously, the valvular structure is made according to the invention with biological tissue such as the pericardium, or with porcine leaflets, which are commonly used in bioprosthetic surgically implanted valves.

**[0108]** Moreover, the valvular prosthesis of the present invention does not induce any significant thrombosis phenomenon during its stay in the blood flow and is biologically neutral.

**[0109]** To prevent the risk of thrombus formation and of emboli caused by clots, a substance with anti-thrombic properties could be used, such as heparine, ticlopidine, phosphorylcholine, etc. either as a coating material or it can be incorporated into the material used for the implantable valve, in particular, for the valvular structure and/or for the internal cover.

**[0110]** The valvular structure of the invention can have several types of designs and shapes. Besides the example illustrated in Figures 4 and 5, examples of strengthened valvular structures according to the invention are shown in Figures 9 to 11, respectively in the closed (figures 9a, 10a, 11a) and in the open state (figures 9b, 10b, 11b) to form a prosthetic valve according to the present invention. In those figures, the frame line is simplified to clarify the drawings.

**[0111]** To help initiate and finalize the closure of the valvular structure, four strengthening struts 14 are slightly inclined from the base to the upper part as compared to the central axis X'X of the structure, as shown in Figures 9a and 9b. Accordingly, a patterned movement of the valvular structure, during the closing and the opening phases, is initiated. This patterned movement is, in the present case, an helicoidal-type one, as suggested in Figures 9b and 10b by the circular arrow.

**[0112]** Figures 10a and 10b illustrate another embodiment to help the closing of the valvular structure and which also involves an helicoidal movement. Represented by lines 22, inclined pleats are formed in the tissue to impart such a movement. As illustrated, these lines have an inclination from the base to the upper part of the tissue 14. Pleats are formed by folding the tissue or by alternating thinner and thicker portions. The width and the number of those pleats are variable, and depend particularly on the type of material used. According to another example, these pleats 34 are combined with the above described inclined strengthening struts.

**[0113]** These reinforcing pleats and/or struts, rectilinear or inclined, have the advantage to impart a reproducible movement and, accordingly, to avoid the valvular structure from closing to a nonstructured collapse on the frame base.

**[0114]** Another shape of the valvular structure comprises two portions: one portion being flexible but with some rigidity, having a rectangular shape, occupying about one third of the circumference of the valvular structure, and the other portion being more supple, flexible and foldable occupying the rest of the circumference at its base as well as at its upper, free border. According to Figure 11c, this valve is opened, during the ejection of blood, i.e., during systol. In Figure 11d, a front view of the valve is closed, during an intermediate diastole, and in Figure 11e the same closed valve during diastole is shown from a side view. The semi-rigid part 24' moves little during systole and during diastole. The foldable part 23' moves away from the rigid part during systole to let the blood flow through the orifice thus made. This orifice, due to the diameter of the upper part which is the same as that of the open stent, is large, generally as large as that of the open stent. At the time of diastole, due to the reverse of pressure, the foldable part moves back towards the semi-rigid part and presses on it, and thus closes the orifice and prevents any regurgitation of blood.

**[0115]** The advantage of such a valve design is to allow a large opening of the upper part of the valvular structure,

not only to permit more blood flow at time of systole after the valve has been implanted, but also at the very time of implantation, when the balloon is maximally inflated to expand the valve to imbed it in the valvular annulus. The diameter of the upper part of the valvular structure could be the same size as the balloon, so that there would be no distension of the valvular part of the valve at the time of implantation, and therefore no risk of deterioration of the valvular structure by the inflated balloon.

**[0116]** The foldable part of the valve could be reinforced by strengthening struts to prevent an eversion of the valve towards the left ventricle during diastole.

**[0117]** Another shape of the valvular structure, as illustrated in Figures 11 a and 11 b comprise four portions, alternatively a main portion 23 and a more narrow portion 24. The main and the narrow portions are facing each other. Each portion has an isosceles trapezoidal shape. The main portions 23 are flexible but with some slight rigidity and the more narrow portions 24 are compliant, more supple and foldable. In this type of design, the two slightly rigid portions 23 maintain the valvular structure closed during diastole by firmly applying on each other in their upper extremities, thus forming a slot-like closure 25. This particular embodiment needs less foldable tissue than in the previous embodiments and the closure of the valvular structure at the time of early diastole does not have any tendency to collapse towards the aortic annulus.

**[0118]** Another design for the valvular structure is a combination of a cylindrical shape followed by a truncated shape.

**[0119]** This type of valvular structure is longer than the hyperboloidal type, for instance, 25 or 30 mm long, therefore exceeding out of the upper part of the metallic frame, by 10 to 20 mm. The cylindrical part corresponds to the metallic frame and remains inside it. The truncated conic shape is the upper part of the valvular structure, totally exceeding out of the upper extremity of the metallic frame. An advantage of such a design is that the balloon can be inflated only in the cylindrical part of the valvular structure, therefore without risk of stretching the truncated conical part of the upper diameter which is smaller than that of the inflated balloon.

**[0120]** When the upper extremity of the cylindrical part has the same size as the lower extremity, there is no difference during balloon inflation in the degree of force exerted by the balloon on the lower and on the upper extremity of the valvular structure. Preferably, rectilinear reinforcing struts are used in this embodiment, to strengthen the valve structure and aid in its shutting without collapsing and inverting inside the left ventricle through the aortic annulus under the force of the diastolic pressure.

**[0121]** Two different processes for implanting a valve according to the present invention are shown respectively in Figures 13a to 13l with a unique balloon catheter, as illustrated in Figures 12a and 12b and in Figures 15a to 15f, with a two-balloon catheter, as illustrated in Figure

14.

**[0122]** The IV positioning in the aortic orifice and its expansion can be performed with the help of a unique substantially cylindrical balloon catheter 26 in the so-called unique-balloon catheterization technique.

**[0123]** Preparing for its introduction by transcatheterous route in the femoral artery, the IV 13 is, as illustrated in the perspective view of Figure 10a in a compressed form crimped on the balloon catheter 26. A central sectional view of the mounted IV 13 on the complete balloon catheter 26 is shown in Figure 12b.

**[0124]** The shaft 27f of the balloon dilatation catheter 26 is as small as possible, i.e., a 7F (2.2 mm) or a 6F (1.9 mm) size. The balloon 26 is mounted on the shaft 27 between two rings R. Moreover, the shaft 27 comprises a lumen 28 (Figure 12b) as large as possible for inflation of the balloon 26 with diluted contrast to allow simple and fast inflation and deflation. It has also another lumen 29 able to accept a stiff guide wire 30, for example 0.036 to 0.038 inches (0.97 mm), to help position the implantable valve with precision.

**[0125]** The balloon 26 has, for example, a 3 to 4 cm length in its cylindrical part and the smallest possible size when completely deflated so that it will be able to be placed inside the folded valve having an outside diameter which ranges between about 4 and 5 mm. Therefore, the folded balloon preferably has at the most a section diameter of about 2.5 to 3 mm.

**[0126]** The balloon is therefore made of a very thin plastic material. It is inflated with saline containing a small amount of contrast dye in such a way to remain very fluid and visible when using X-ray.

**[0127]** However, the balloon 26 has to be sufficiently strong to resist the high pressure that it has to withstand to be capable of expanding the folded valvular structure 14 and the compressed frame in the stenosed aortic orifice considering that, although pre-dilated, the aortic orifice still exerts a quite strong resistance to expansion because of the recoil phenomenon.

**[0128]** This procedure is shown in Figures 13a to 13e.

**[0129]** In contrast to the technique used when performing the usual aortic dilatation (without valve implantation), i.e., inflating the balloon maximally markedly above the nominal pressure, if possible, up to the bursting point (which occurs always with a longitudinal tear, without deleterious consequence, and with the advantage of both exerting a maximal dilating force and restoring blood ejection instantaneously), the balloon inflated for expansion of an implantable valve should not burst in any case. Indeed, bursting of the balloon would involve a risk of incomplete valve expansion and wrong positioning. Therefore, the balloon should be very resistant to a very high pressure inflation. Furthermore, the balloon is inflated only up to the nominal pressure indicated by the maker and the pressure is controlled during inflation by using a manometer. Such relatively low pressure should be sufficient since prior to positioning the IV, an efficacious dilatation of the stenosed aortic valve according to the usual

technique with a maximally inflated balloon for example 20 mm or 25 mm in size in such a way to soften the distorted valvular tissue and facilitate the enlargement of the opening of the valve at time of IV implantation is performed.

**[0130]** The implantation of the aortic valve 20 can be made in two steps, as described as follows.

**[0131]** The first step, as shown in Figures 13a to 13f, consists in introducing the shaft 27 and balloon catheter 26 along the guide wire previously positioned in the ventricle 4 (Figures 13a-13b). The dilatation of the stenosed aortic valve 1', 2' using a regular balloon catheter, according to the commonly performed procedure, i.e., with the guide wire 30 introduced in the ventricle 4 (Figure 13a) and with maximal inflation of the balloon 26 (Figures 13c to 13d) up to the bursting point. Dilatation is performed at least with a balloon having about 20 mm diameter, but it can be performed with a balloon having about 23 mm diameter so as to increase maximally the aortic orifice opening before implantation of the valve although the implantable valve is about 20 mm in diameter. This preliminary dilatation of the aortic orifice helps in limiting the force required to inflate the balloon used to expand the implantable valve and position it in the aortic orifice, and also in limiting the recoil of the aortic valve that occurs immediately after balloon deflation. The balloon is deflated (Figure 13a) and pulled back on the wire guide 30 left inside the ventricle.

**[0132]** Owing to the marked recoil of the stenosed valve and also of the strong aortic annulus, the 20 mm diameter valve is forcefully maintained against the valvular remains at the level of the aortic annulus. Preliminary dilatation has another advantage in that it permits an easier expansion of the IV, having a lower pressure balloon inflation which helps prevent damage of the valvular structure of the IV. This also facilitates the accurate positioning of the prosthetic valve.

**[0133]** The second step corresponds to the implantation of the valve 13 is shown in Figures 13g to 13l. The positioning of the IV needs to be precise at a near 2 or 3 mm, since the coronary ostia 6 has to remain absolutely free of any obstruction by the valve 13 (Figures 13k and 13l). As mentioned above, this is, for example, performed with the help of the image of the sus-valvular angiogram in the same projection fixed on an adjacent TV screen. The expansion and the positioning of the valve prosthesis 13 is performed within a few seconds (15 to 20 among at most) since during the maximal balloon inflation (which has to be maintained only a very few seconds, 3, 4, 5) the aortic orifice is obstructed by the inflated balloon 31 and the cardiac output is zero (Figure 13h). As for the pre-dilatation act itself, the balloon 26 is immediately deflated within less than 5 or 6 seconds (Figure 13j) and, as soon as the deflation has clearly begun, the closing and opening states of the IV are active whereas the balloon is pulled back briskly in the aorta (Figures 13j to 13l). In case the IV is not maximally expanded by the first inflation, it is possible to replace the balloon inside the

IV and to reinflate it so as to reinforce the expansion of the IV.

**[0134]** The IV 13 can also be used in aortic regurgitation. This concerns more often younger patients rather than those with aortic stenosis. The contraindication to surgical valve replacement is often not due to the old age of the patients, but stems mainly from particular cases where the general status of the patient is too weak to allow surgery, or because of associated pathological conditions. Apart from the fact that there is no need for a preliminary dilatation, the procedure of the valve implantation remains approximately the same. The balloon inflation inside the IV is chosen accordingly, taking also into account the fact that it is necessary to overdilate the aortic annulus to obtain a recoil phenomenon of the annulus after balloon deflation to help maintain the IV in position without any risk of displacement.

**[0135]** However, the size of the expanded implantable valve is around 25 to 30 mm in diameter, or even bigger, because the aortic annulus is usually enlarged. A preliminary measurement of the annulus will have to be performed on the sus-valvular angiography and by echocardiography to determine the optimal size to choose.

**[0136]** The IV can be used in the mitral position, mainly in case of mitral regurgitation, but also in case of mitral stenosis. Here again, the IV 20 is only described when used only in cases of contraindication to surgical valve repair or replacement. The procedure is based on the same general principles though the route for the valve positioning is different, using the transseptal route, like the commonly performed mitral dilatation procedure in mitral stenosis. The IV size is quite larger than for the aortic localization (about 30 to 35 mm in diameter when expanded or clearly above in case of a large mitral annulus, a frequent occurrence in mitral insufficiency), to be capable of occupying the mitral area. A preliminary measurement of the mitral annulus is performed to determine the optimal implantable valve size to choose. Since the introduction of the IV is performed through a venous route, almost always through the femoral vein which is quite large and distensible, the bigger the size of the IV in its compressed position is not a drawback even if the diameter size is about 6 or 7 mm. Moreover, the problem of protection of the coronary ostia as encountered in the aortic position does not exist here which therefore makes the procedure easier to be performed.

**[0137]** Finally, the IV can be used to replace the tricuspid valve in patients with a tricuspid insufficiency. This procedure is simple to perform since the positioning of the IV is made by the venous route, using the shortest way to place in the right position at the level of the tricuspid orifice practically without any danger from clot migration during the procedure. A large implantable valve is used, with a diameter of about 40 mm or even larger because the tricuspid annulus is often markedly dilated in tricuspid insufficiency. Here also, as in the mitral position, the compressed IV and the catheter used can be without inconvenience, quite larger than that for the aortic

position because of the venous route used.

**[0138]** Furthermore, it has to be noted that the IV can be used also as a first step in the treatment of patients who have contraindication to surgery, when they are examined for the first time, but who could improve later on after correction of the initial hemodynamic failure. The IV procedure can be used as a bridge towards surgery for patients in a weak general condition which are expected to improve within the following weeks or months after the IV procedure in such a way that they can be treated by open heart surgery later on. In the same vein, the IV procedure can be used as a bridge towards surgical valve replacement or repair in patients with a profoundly altered cardiac function that can improve secondarily owing to the hemodynamic improvement resulting from the correction of the initial valvular disease by the IV implantation.

**[0139]** Another technique for implantation of an aortic valve by transcatheterization uses a two-balloon catheter.

**[0140]** An example of this technique using the two parts IV with a two-balloon catheter 40 is shown in Figure 14.

**[0141]** Two-balloons 26 and 26' are fixed on a unique catheter shaft 27, said balloons being separated by a few millimeters. The two balloons are preferably short, i.e., about 2 to 2.5 cm long in their cylindrical part. The first balloon 26 to be used, carries a first frame 10 aimed at scaffolding the stenosed aortic orifice after initial dilatation. This first balloon 26 is positioned on the aorta side, above the second balloon 26' which is positioned on the left ventricle side. The second balloon 26' carries the expandable valve 13 which is of the type described above made of a second frame 10' and a valvular structure 14 attached to said frame 10'. The difference is that the second frame does not need to be as strong as the first frame and is easier to expand with low balloon pressure inflation which does not risk damaging the valvular structure 14.

**[0142]** This enlarges the choice for making a valvular structure without having to face two contradictory conditions:

- 1) having a soft and mobile valvular structure 14 capable of opening and closing freely in the blood stream without risk of being damaged by a balloon inflation; and
- 2) needing a reinforced frame strong enough to be capable of resisting without any damage, a strong pressure inflation of the expanding balloon.

**[0143]** The shaft 27 of this successive two-balloon catheter 40 comprises two lumens for successive and separate inflation of each balloon. Indeed, an additional lumen capable of allowing a fast inflation occupies space in the shaft and therefore an enlargement of the shaft is necessary. However, this enlargement of the shaft stops at the level of the first balloon 26 since, further to said first balloon, only one lumen is necessary to inflate the

second balloon 26', at the level of the IV which is the biggest part of the device.

**[0144]** Another advantage of this two part IV with a two-balloon catheter is that each set of implantable valve and balloon has a smaller external diameter since each element to be expanded, considered separately, is smaller than in combination. This allows obtaining more easily a final device with an external diameter 14 F.

**[0145]** The first balloon is sufficiently strong to avoid bursting even at a very high pressure inflation. This first balloon is mounted in the frame in its deflated position, prior to its introduction by the strong frame which is aimed to scaffold the dilated stenosed aortic valve. The size and shape of said frame is comparable to what has been described previously but said frame is calculated (in particular the material, the number and diameter of its bars are chosen by the person skilled in the art) to make sure that it will resist the recoil of the dilated valve and that it will be securely embedded in the remains of the native aortic valve.

**[0146]** The second balloon does not need to be as strong as the first one and, therefore, can be thinner, occupying less space and being easier to expand with a lower pressure for balloon inflation. This second balloon 26' is mounted in the valve itself which, as in the preceding description, comprises a frame to support the valvular structure and said valvular structure.

**[0147]** Also, the second frame 10' does not need to be as strong as the first one. This frame can be slightly shorter, 10 mm instead of 12 mm, and its bars can be thinner. This frame can have an external surface which is a bit rough to allow better fixation on the first frame when expanded. The bars may also have some hooks to fasten to the first frame.

**[0148]** The valvular structure is attached on said second frame and expanded by relatively low pressure in the second balloon called hereafter the IV balloon. It does not need to be as strong as in the preceding case (IV in one part and unique balloon catheter technique) and, therefore, it occupies less space and has less risk to be damaged at the time of expansion.

**[0149]** This technique is shown in Figures 15a to 15f.

**[0150]** One of the problems relevant to the IV implantation procedure as described above, with the IV in one part, is the expansion at the same time by the same balloon inflation of both the frame and the valvular structure. Indeed, the frame is a solid element and the valvular structure is a relative weak one that could be damaged when squeezed by the inflated balloon.

**[0151]** Therefore, the valve implantation can be performed in two immediately successive steps. The first step (Figures 15a-15b) corresponds to the expansion and the positioning of the first frame with the first balloon 26 wherein inflation is performed at a high pressure. The second step (Figures 15d-15e) corresponds to the expansion and the positioning of the valvular structure 14 inside the frame 10' using the second balloon 26'. This second step follows the first one within a few seconds

because, in the time interval between the two steps, there is a total aortic regurgitation towards the left ventricle which is an hemodynamic condition that cannot be maintained for more than a few heart beats, i.e., a few seconds, without inducing a massive pulmonary edema and a drop to zero of the cardiac output.

**[0152]** In another embodiment, the first frame to be introduced comprises the valvular structure and the second frame being stronger than the first one to scaffold the previously deleted stenosed aortic valve.

**[0153]** The advantage of this two step procedure would be to allow expansion and positioning of the frame part 10' of the IV 13 using strong pressure inflation of the balloon 26' without the risk of damaging the valvular structure 14 which, for its own expansion, would need only light pressure inflation.

**[0154]** The method is schematically detailed in Figures 15a to 15f. A previous dilatation of the stenosed aortic valve is performed as an initial step of the procedure to prepare the distorted valve to facilitate the following steps:

1/ positioning the double balloon catheter 40 with the first balloon 26 with the frame at the level of the aortic annulus 2a, the second IV balloon 26' being inside the left ventricle beyond the aortic annulus 2a (Figure 15a);

2/ compression of the stenosed aortic valve 1', 2' with the first balloon 26 having a 20 mm, preferably with a 23 mm diameter, the balloon being inflated maximally up to the bursting point, to prepare the IV insertion (Figure 15b). Inflation lasts a few seconds (preferably 10 seconds at most) with powerful pressure being used to expand the frame and forcefully embed said frame in the remains of the dilated valve;

3/ an immediate speedy deflation of said first balloon 26 follows (Figure 15c); as soon as the balloon 26 is beginning to clearly deflate, the first frame 10 remaining attached to the stenosed valve 1', 2', the catheter 40 is withdrawn to position the IV balloon 26' inside the previously expanded frame 26 (Figure 15c in which the frame 10' is partially drawn for clarity purpose);

4/ immediately after being well positioned, the IV balloon 26' is promptly inflated, to expand the IV 13 (Figure 15c); and

5/ when the IV 13 is blocked inside the first frame 10, the IV balloon 26' is deflated (Figure 18f).

**[0155]** Finally, the whole device has to be withdrawn to allow hemostasis of the femoral artery puncture hole.

**[0156]** The total duration of the successive steps, particularly the time during which the balloons are inflated, and the time during which the frame is expanded whereas the valve has not yet been positioned and expanded, is about 20 to 30 seconds. This is feasible if the balloons are inflated and deflated within very a few seconds, 6 to 8, for instance. This is permitted if the lumen of the shaft

can be sufficiently large, taking into account the inescapable small diameter size of the shaft. This can also be facilitated by a device producing instantaneously a strong inflation or deflation pressure.

## Claims

1. A prosthetic valve assembly for implantation in a stenotic native aortic valve, comprising:

a metallic frame (10) having upper and lower extremities and wherein at least a portion of said frame has a concave profile between said upper and lower extremities, said frame being compressible to an external diameter capable of being introduced through an 18F (5,7mm) arterial introducer for advancing the prosthetic valve assembly through a patient's vasculature using a catheterization technique and said frame being expandable for implantation within said stenotic native aortic valve;

a collapsible valvular structure (14) sewn to said frame between said upper and lower extremities, said valvular structure being formed of pericardial tissue for occluding blood flow in one direction; and

an internal cover (19) made with the same tissue as the valvular structure, said internal cover having an upper end coupled to said valvular structure and a lower end attached to said lower extremity of said frame, said internal cover sewn to a wall of said frame and extending along an internal surface of said wall of said frame only between said valvular structure and said lower extremity of said frame for preventing regurgitation of blood through said wall of said frame below said valvular structure.

2. The prosthetic valve assembly of claim 1, wherein said internal cover is sewn to the lower extremity of said frame (10) along a zig-zag line.

3. The prosthetic valve assembly of claim 1, wherein said upper extremity of said frame (10) presents an opening out (12) or is flared.

4. The prosthetic valve assembly of claim 1, wherein said lower extremity of said frame (10) presents an opening out (12) or is flared.

5. The prosthetic valve assembly of claim 1, wherein said internal cover (19) is integral with said valvular structure (14).

6. The prosthetic valve assembly of claim 1, wherein said frame (10) is expandable to a size of about 20 to 25 millimeters.

7. The prosthetic valve assembly of claim 1, wherein said valvular structure (14) forms a continuous surface and is provided with guiding means (17).
8. The prosthetic valve assembly of claim 7, wherein said guiding means (17) create stiffened zones which induce said valvular structure (14) to follow a patterned movement when moving from a closed state to an open state.
9. The prosthetic valve assembly of claim 8, wherein said guiding means (17) are further configured to prevent eversion of said valvular structure (14).
10. The prosthetic valve assembly of claim 1, wherein said frame is further compressible to an external diameter of about 4 to 5 millimeters.
11. The prosthetic valve assembly of claim 1, wherein said frame is further compressible to an external diameter capable of being introduced through a 16F (5,1mm) arterial introducer.
12. The prosthetic valve assembly of claim 1, wherein said frame is further compressible to an external diameter capable of being introduced through a 14F (4,5mm) arterial introducer.
13. The prosthetic valve assembly of claim 1, wherein said frame is formed with intercrossing bars.
14. The prosthetic valve assembly of claim 13, wherein said intercrossing bars are rounded and smooth linear bars.
15. The prosthetic valve assembly of claim 1, wherein said frame is formed with a plurality of bars having spaces therebetween and wherein a diameter of said bars is in a range of 0,1 to 0,6 mm for being forcefully embedded in a remains of the stenotic aortic valve and to resist a recoil force of an aortic annulus.

#### Patentansprüche

1. Herzklappenprothesenanordnung zur Implantation in eine stenotische natürliche Aortenklappe, umfassend:
- einen metallischen Rahmen (10), der obere und untere Endbereiche hat, wobei zumindest ein Teil des Rahmens ein konkaves Profil zwischen den oberen und den unteren Endbereichen hat, wobei der Rahmen auf einen Außendurchmesser zusammendrückbar ist, bei dem er durch eine 18F-(5,7mm) Arterieneinführungsvorrichtung eingeführt werden kann, um die Herzklappenprothesenanordnung durch die Blutgefäße

eines Patienten mittels einer Katheterisierungstechnik vorwärts bewegen zu können, und der Rahmen zur Implantation innerhalb der stenotischen natürlichen Aortenklappe expandierbar ist;

eine einfaltbare Klappenstruktur (14), die an den Rahmen zwischen den oberen und den unteren Endbereichen genäht ist, wobei die Klappenstruktur aus Perikard ausgebildet ist, um Blutfluss in eine Richtung aufzuhalten; und

eine innere Abdeckung (19), die aus dem gleichen Gewebe gefertigt ist wie die Klappenstruktur, wobei die innere Abdeckung ein oberes Ende aufweist, das mit der Klappenstruktur verbunden ist, und ein unteres Ende, das mit dem unteren Endbereich des Rahmens verbunden ist, wobei die innere Abdeckung an eine Wandung des Rahmens genäht ist und sich entlang einer inneren Oberfläche der Wandung des Rahmens nur zwischen der Klappenstruktur und dem unteren Endbereich des Rahmens erstreckt, um eine Regurgitation von Blut durch die Wandung des Rahmens unter der Klappenstruktur zu verhindern.

2. Herzklappenprothesenanordnung gemäß Anspruch 1, wobei die innere Abdeckung an den unteren Endbereich des Rahmens (10) entlang einer Zick-Zack-Linie angenäht ist.
3. Herzklappenprothesenanordnung gemäß Anspruch 1, wobei der obere Endbereich des Rahmens (10) eine Aufweitung (12) aufweist oder aufgetrichert ist.
4. Herzklappenprothesenanordnung gemäß Anspruch 1, wobei der untere Endbereich des Rahmens (10) eine Aufweitung (12) aufweist oder aufgetrichert ist.
5. Herzklappenprothesenanordnung gemäß Anspruch 1, wobei die innere Abdeckung (19) und die Klappenstruktur (14) einstückig ist.
6. Herzklappenprothesenanordnung gemäß Anspruch 1, wobei der Rahmen (10) auf eine Größe von etwa 20 bis 25 Millimeter expandierbar ist.
7. Herzklappenprothesenanordnung gemäß Anspruch 1, wobei die Klappenstruktur (14) eine durchgehende Oberfläche ausbildet und mit Führungselementen (17) versehen ist.
8. Herzklappenprothesenanordnung gemäß Anspruch 7, wobei die Führungselemente (17) versteifte Bereiche ausbilden, die dazu führen, dass die Klappenstruktur (14) einem Bewegungsmuster folgt, wenn sie sich von einem geschlossenen Zustand in einen offenen Zustand bewegt.

9. Herzklappenprothesenanordnung gemäß Anspruch 8, wobei die Führungselemente (17) ferner dazu konfiguriert sind, eine Eversion der Klappenstruktur (14) zu verhindern.
10. Herzklappenprothesenanordnung gemäß Anspruch 1, wobei der Rahmen ferner bis zu einem Außendurchmesser von etwa 4 bis 5 Millimeter zusammendrückbar ist.
11. Herzklappenprothesenanordnung gemäß Anspruch 1, wobei der Rahmen ferner auf einen Außendurchmesser zusammendrückbar ist, bei dem er durch eine 16F-(5,1mm) Arterieneinführungsvorrichtung eingeführt werden kann.
12. Herzklappenprothesenanordnung gemäß Anspruch 1, wobei der Rahmen ferner auf einen Außendurchmesser zusammendrückbar ist, bei dem er durch eine 14F-(4,5mm) Arterieneinführungsvorrichtung eingeführt werden kann.
13. Herzklappenprothesenanordnung gemäß Anspruch 1, wobei der Rahmen aus sich kreuzenden Stäben gebildet ist.
14. Herzklappenprothesenanordnung gemäß Anspruch 13, wobei die sich kreuzenden Stäbe gerundete und glatte Linearstäbe sind.
15. Herzklappenprothesenanordnung gemäß Anspruch 1, wobei der Rahmen aus einer Vielzahl von Stäben gebildet ist, zwischen denen Leerräume ausgebildet sind und wobei der Durchmesser der Stäbe im Bereich von 0,1 bis 0,6 mm liegt, um mit Kraft in die Reste der stenotischen Aortenklappe eingesetzt zu werden und um einer Rückstellkraft durch einen Aortenannulus zu widerstehen.

#### Revendications

1. Ensemble formant valve prothétique pour l'implantation dans une valve de l'aorte native sténosée, comprenant :
- un cadre métallique (10) ayant une extrémité supérieure et une extrémité inférieure et dans lequel au moins une portion dudit cadre possède un profil concave entre ladite extrémité supérieure et ladite extrémité inférieure, ledit cadre étant compressible à un diamètre extérieur capable d'être introduit à travers un dispositif d'introduction artérielle de 18F (5,7 mm) pour faire avancer l'ensemble formant valve prothétique à travers le système vasculaire d'un patient en utilisant une technique par cathéter, et ledit cadre étant expansible pour son implantation dans la-

dite valve d'aorte native sténosée ;  
 une structure de valve (14) capable de s'écraser, cousu sur ledit cadre entre ladite extrémité supérieure et ladite extrémité inférieure, ladite structure de valve étant formée de tissu péricardique pour faire occlusion à l'écoulement du sang dans une direction ; et  
 un revêtement interne (19) réalisé avec le même tissu que la structure de valve, ledit revêtement interne ayant une extrémité supérieure couplée à ladite structure de valve et une extrémité inférieure attachée à ladite extrémité inférieure dudit cadre, ledit revêtement interne étant cousu à une paroi dudit cadre et s'étendant le long d'une surface intérieure de ladite paroi dudit cadre uniquement entre ladite structure de valve et ladite extrémité inférieure dudit cadre pour empêcher un reflux du sang à travers ladite paroi dudit cadre au-dessous de ladite structure de valve.

2. Ensemble formant valve prothétique selon la revendication 1, dans lequel ledit revêtement interne est cousu sur l'extrémité inférieure dudit cadre (10) le long d'une ligne en zigzag.
3. Ensemble formant valve prothétique selon la revendication 1, dans lequel ladite extrémité supérieure dudit cadre (10) présente une ouverture vers l'extérieur (12) ou est évasée.
4. Ensemble formant valve prothétique selon la revendication 1, dans lequel ladite extrémité inférieure dudit cadre (10) présente une ouverture vers l'extérieur (12) ou est évasée.
5. Ensemble formant valve prothétique selon la revendication 1, dans lequel ledit revêtement interne (19) est réalisé de manière intégrale avec ladite structure de valve (14).
6. Ensemble formant valve prothétique selon la revendication 1, dans lequel ledit cadre (10) est capable d'être mis en expansion jusqu'à une taille d'environ 20 à 25 mm.
7. Ensemble formant valve prothétique selon la revendication 1, dans lequel ladite structure de valve (14) forme une surface continue et est pourvue de moyens de guidage (17).
8. Ensemble formant valve prothétique selon la revendication 7, dans lequel lesdits moyens de guidage (17) produisent des zones rigidifiées qui induisent ladite structure de valve (14) à suivre un mouvement obéissant à un motif lorsqu'elle se déplace depuis un état fermé vers un état ouvert.
9. Ensemble formant valve prothétique selon la reven-

dication 8, dans lequel lesdits moyens de guidage (17) sont en outre configurés pour empêcher une éversion de ladite structure de valve (14).

10. Ensemble formant valve prothétique selon la revendication 1, dans lequel ledit cadre est en outre compressible à un diamètre extérieur d'environ 4 à 5 mm. 5
11. Ensemble formant valve prothétique selon la revendication 1, dans lequel ledit cadre est en outre compressible à un diamètre extérieur capable d'être introduit à travers un dispositif d'introduction artérielle de 16F (5,1 mm). 10
12. Ensemble formant valve prothétique selon la revendication 1, dans lequel ledit cadre est en outre compressible à un diamètre extérieur capable d'être introduit à travers un dispositif d'introduction artérielle de 14F (4,5 mm). 15
13. Ensemble formant valve prothétique selon la revendication 1, dans lequel ledit cadre est formé avec des barres qui se croisent mutuellement. 20
14. Ensemble formant valve prothétique selon la revendication 13, dans lequel lesdites barres qui se croisent mutuellement sont des barres linéaires arrondies et lisses. 25
15. Ensemble formant valve prothétique selon la revendication 1, dans lequel ledit cadre est formé avec une pluralité de barres ayant des espaces entre elles, et dans lequel un diamètre desdites barres est dans une plage de 0,1 à 0,6 mm pour être noyées à force dans une partie restante de la valve de l'aorte sténosée pour résister à une force de recul d'un anneau aortique. 30  
35

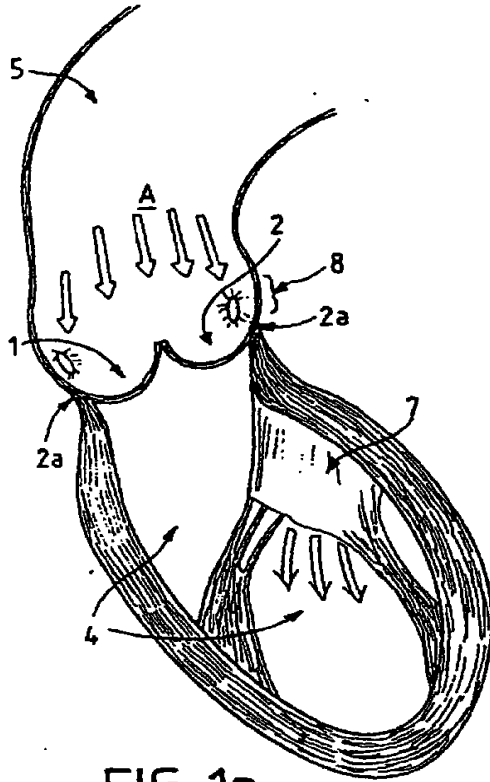
40

45

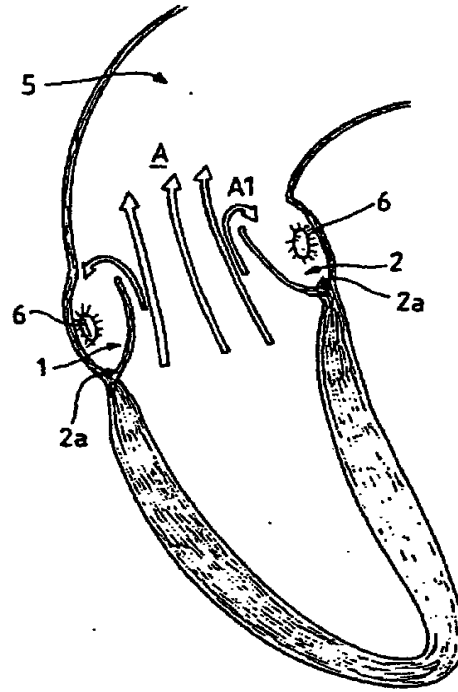
50

55

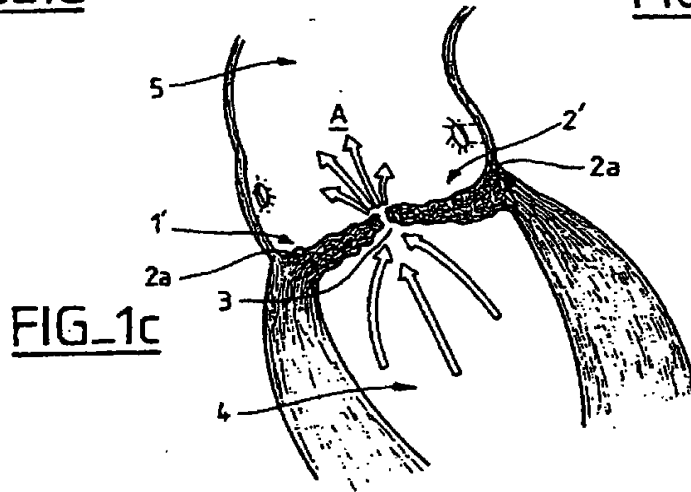




FIG\_1a



FIG\_1b



FIG\_1c

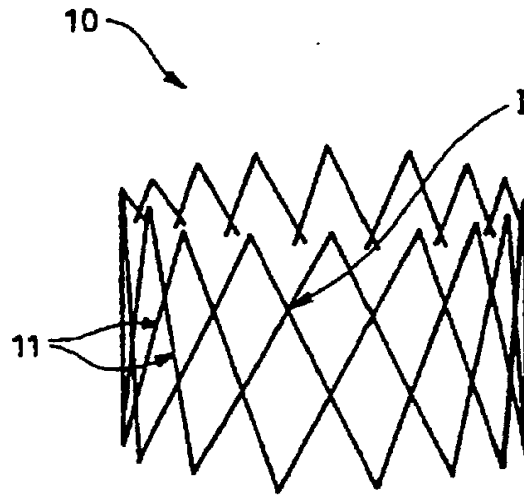


FIG. 2a



FIG. 2b

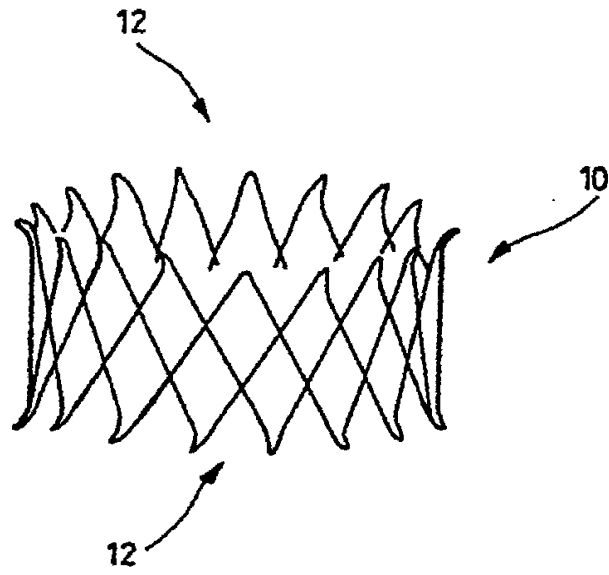


FIG. 3a

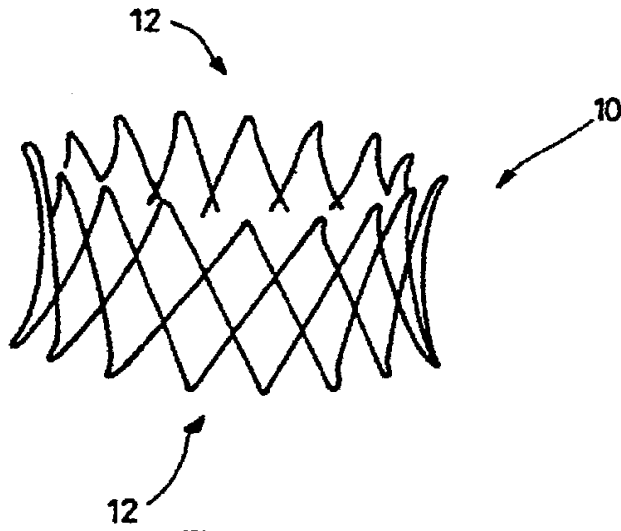
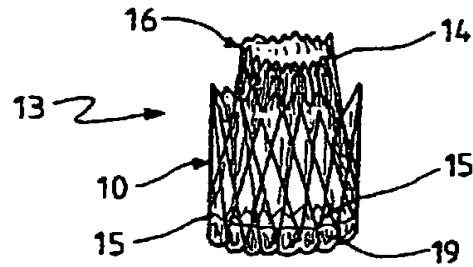
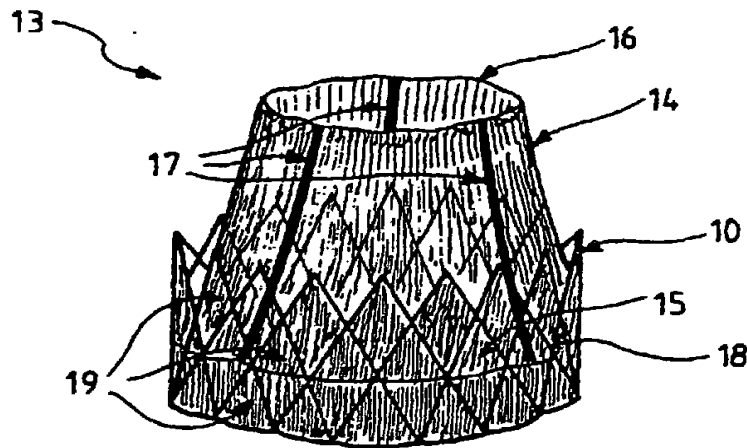


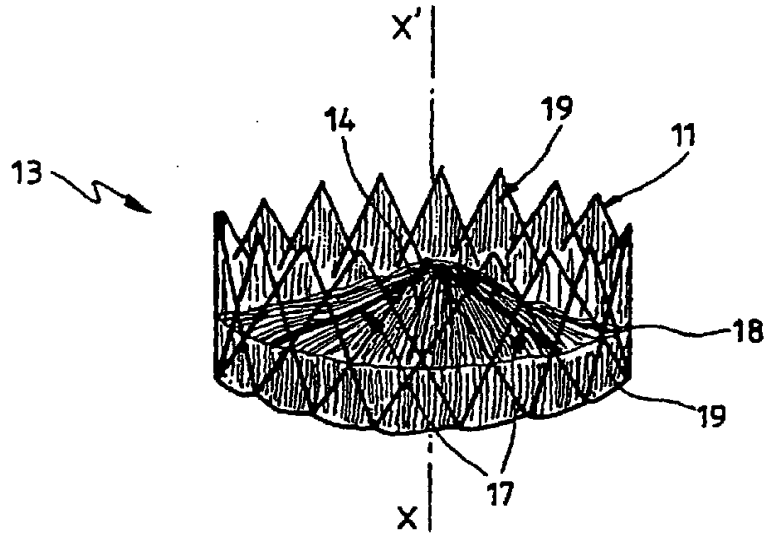
FIG. 3b



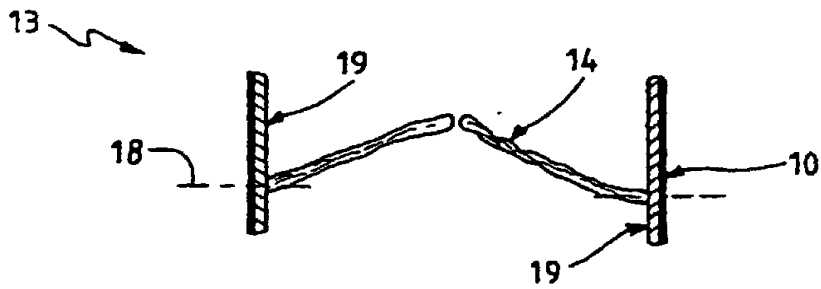
FIG\_4a



FIG\_4b



FIG\_5a



FIG\_5b

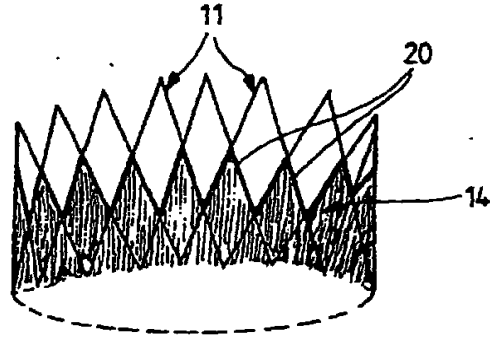


FIG. 7

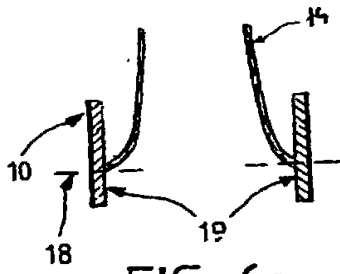


FIG. 6a

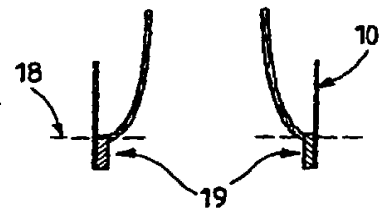


FIG. 6b

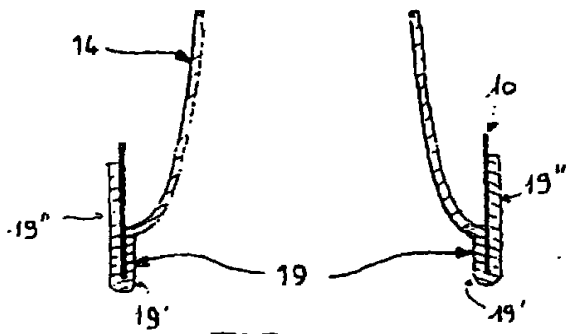


FIG. 6d

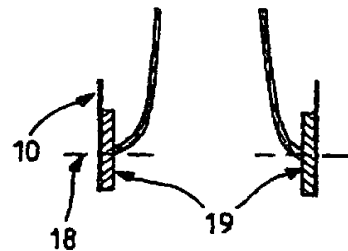
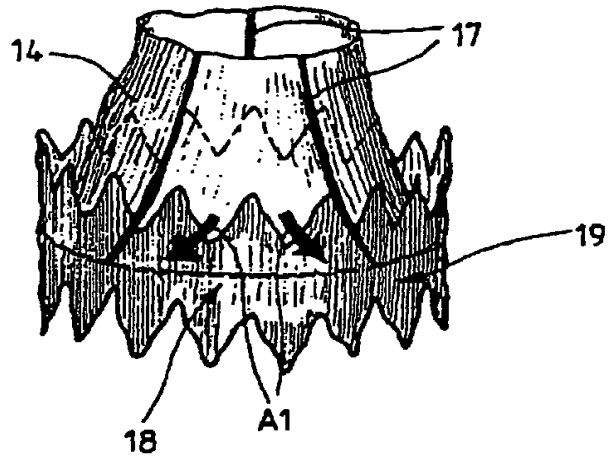
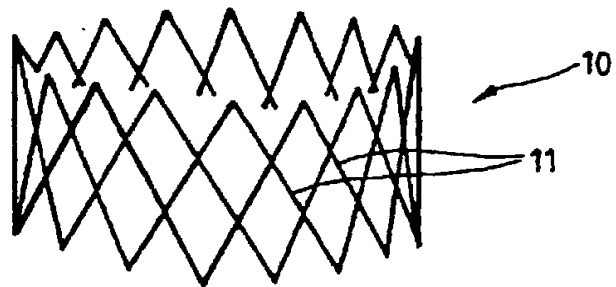


FIG. 6c



FIG\_8a



FIG\_8b

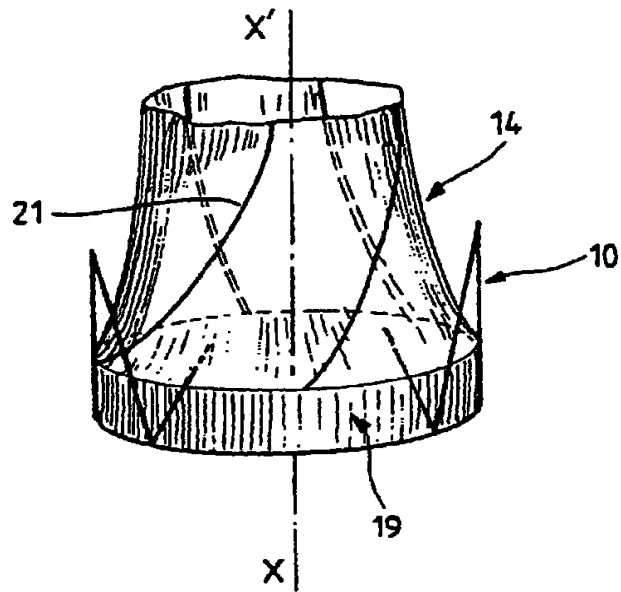


FIG. 9a

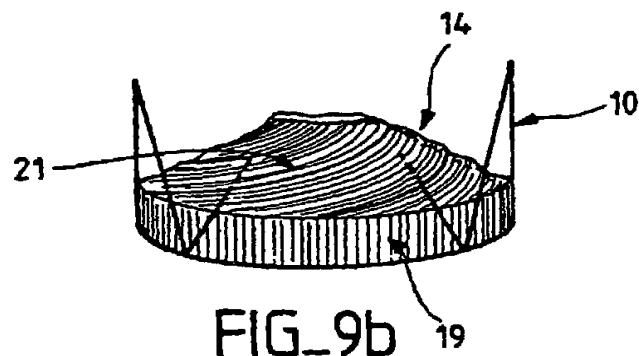
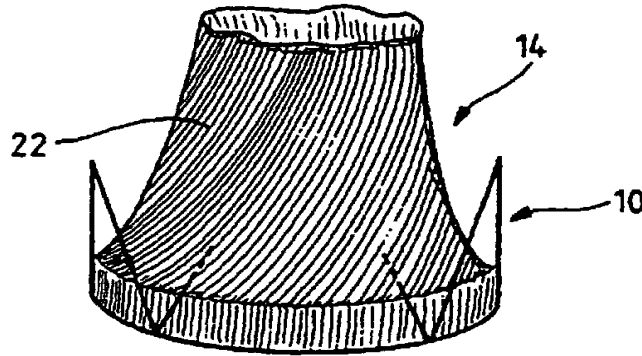
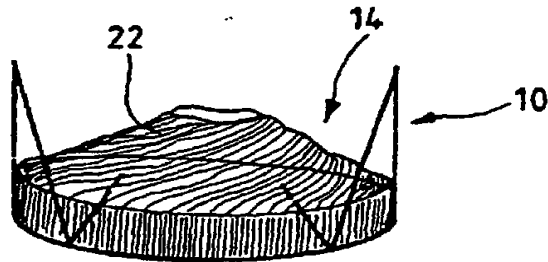


FIG. 9b

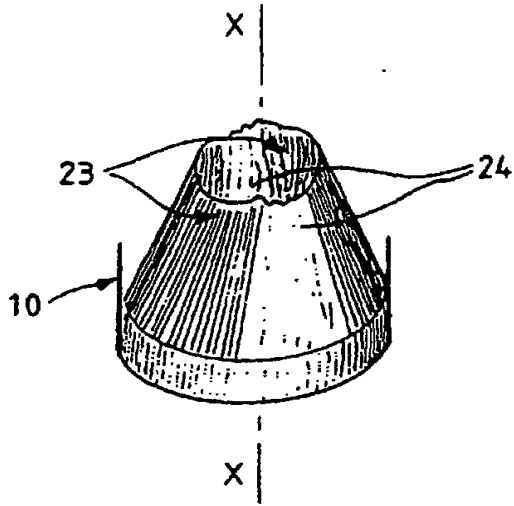




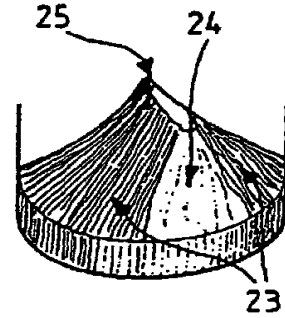
FIG\_10a



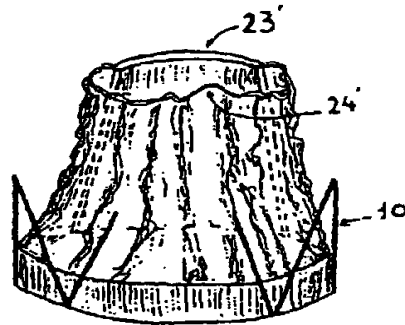
FIG\_10b



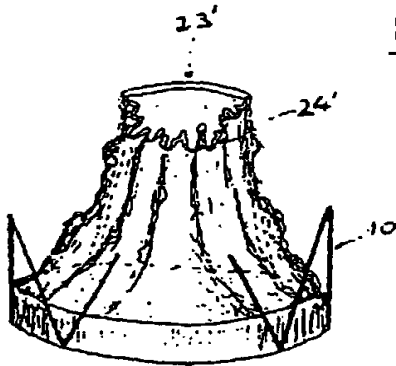
FIG\_11a



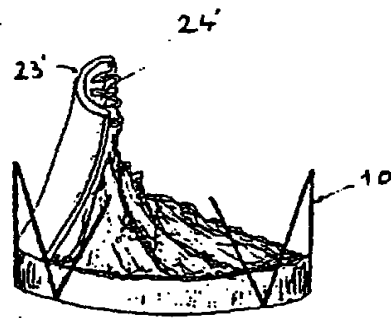
FIG\_11b



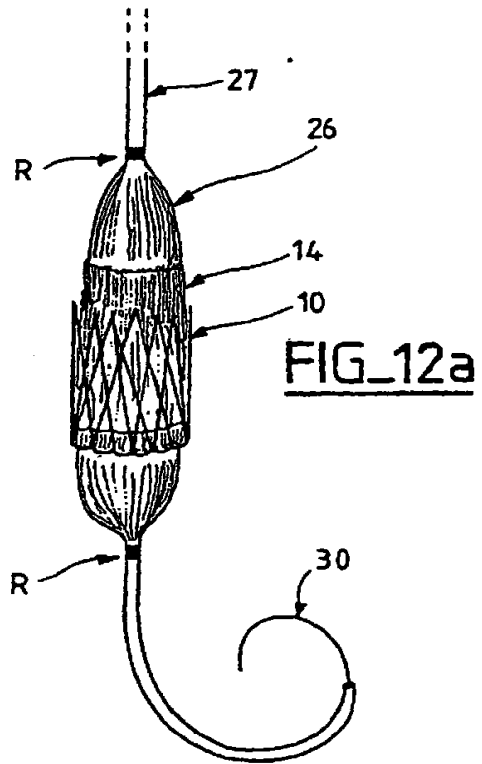
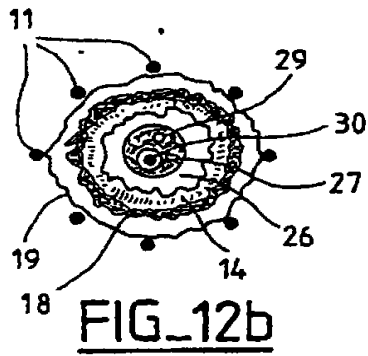
FIG\_11c



FIG\_11d



FIG\_11e



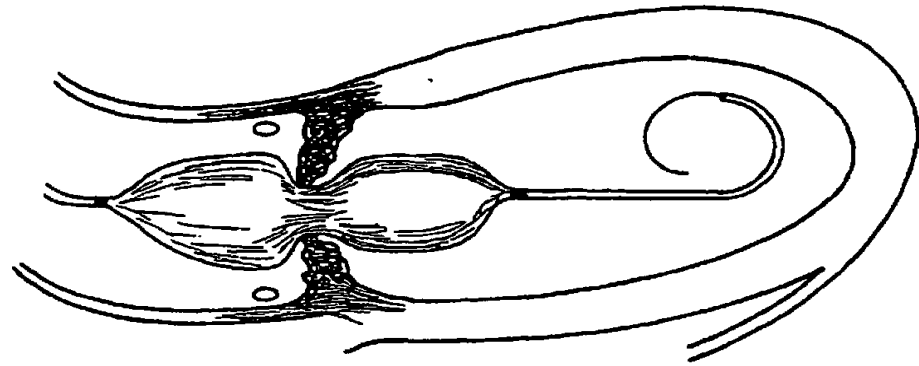


FIG. 13c

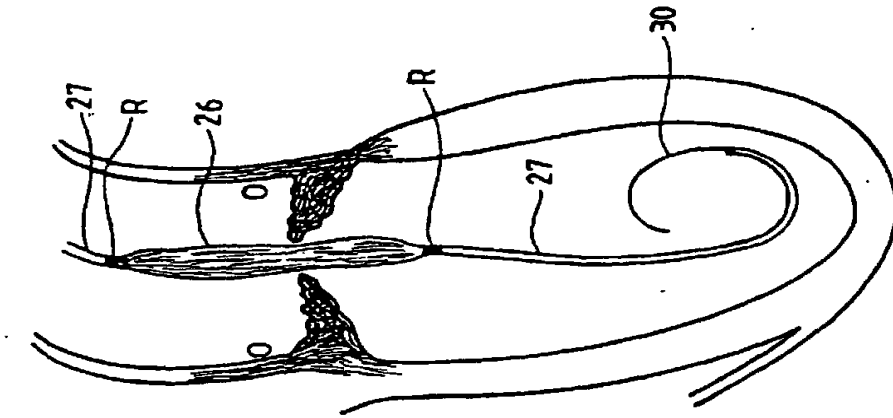


FIG. 13b

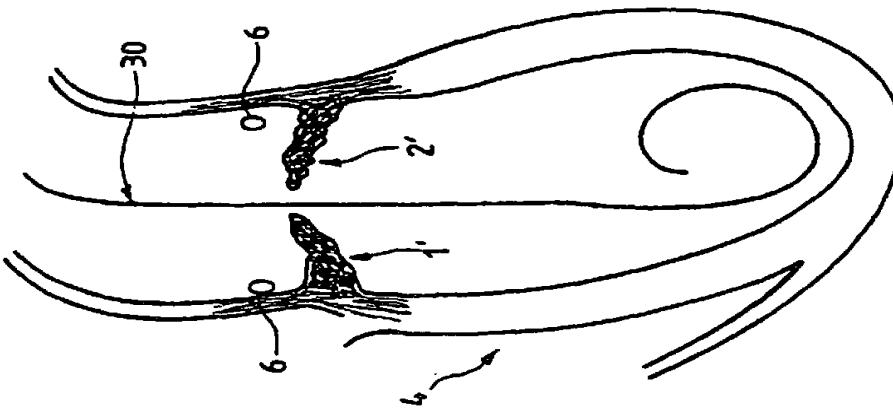
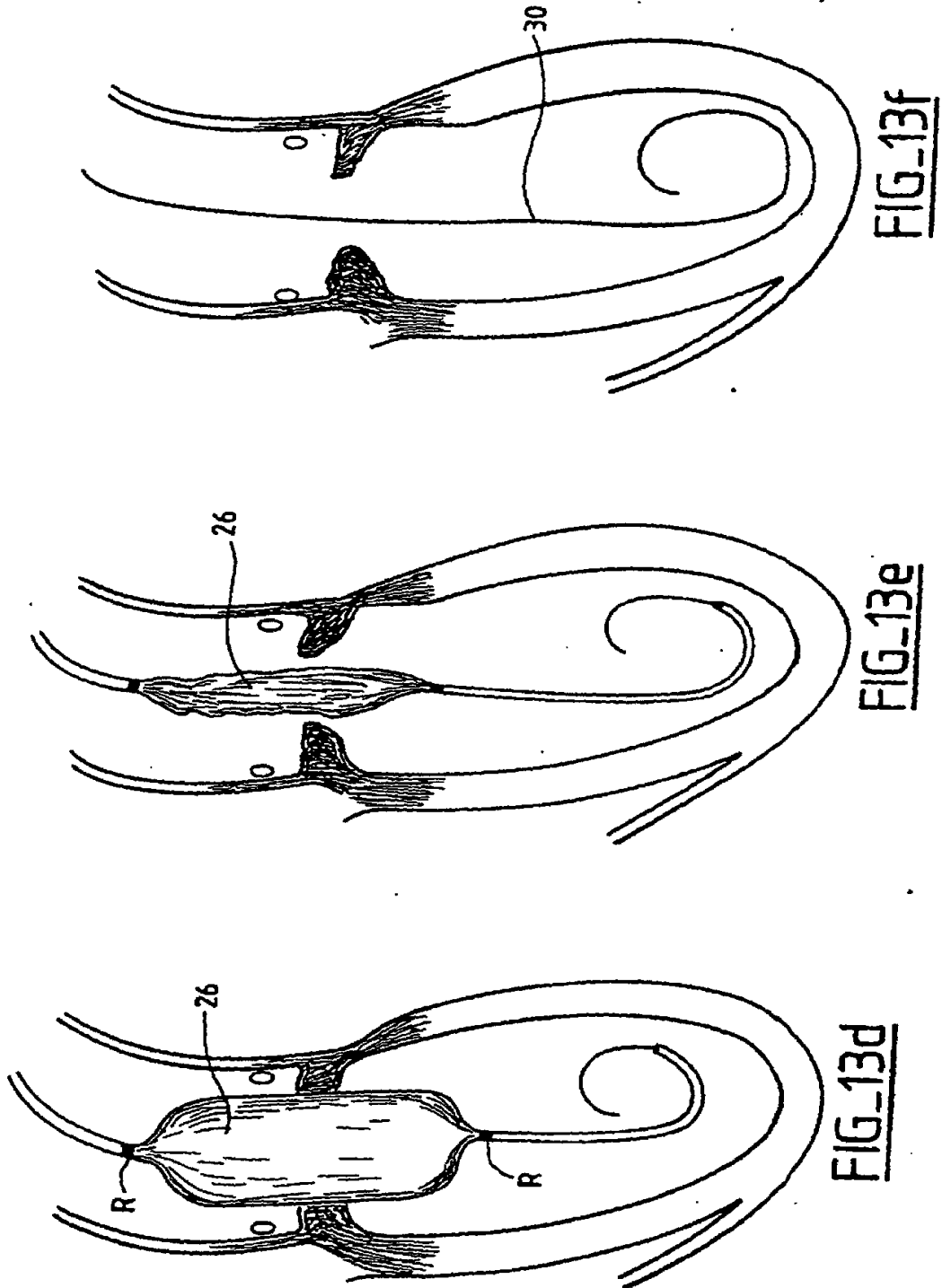


FIG. 13a



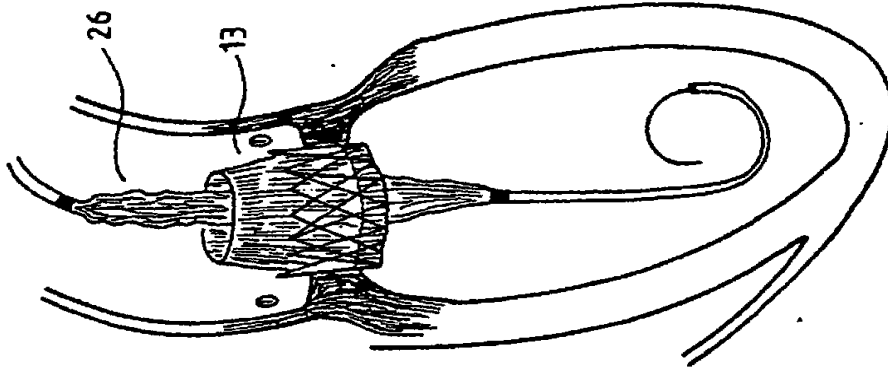


FIG. 13i

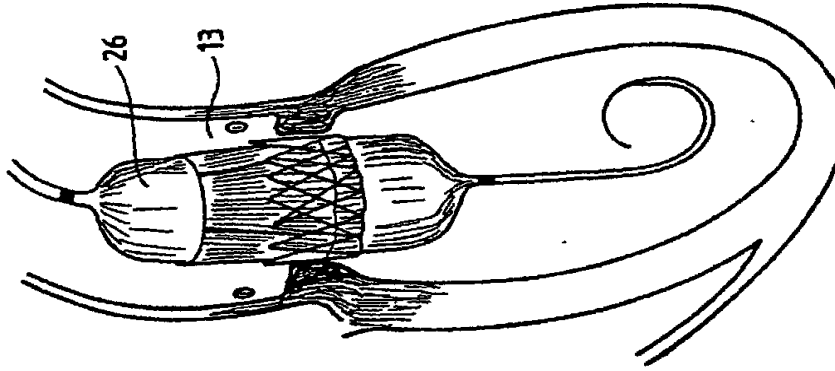


FIG. 13h

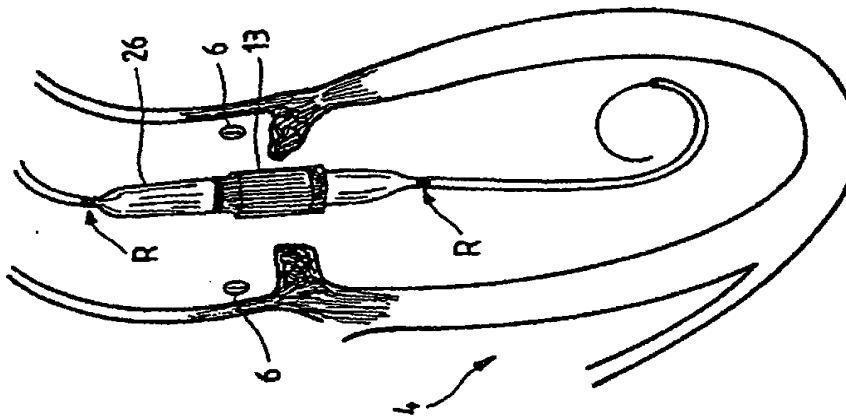


FIG. 13g

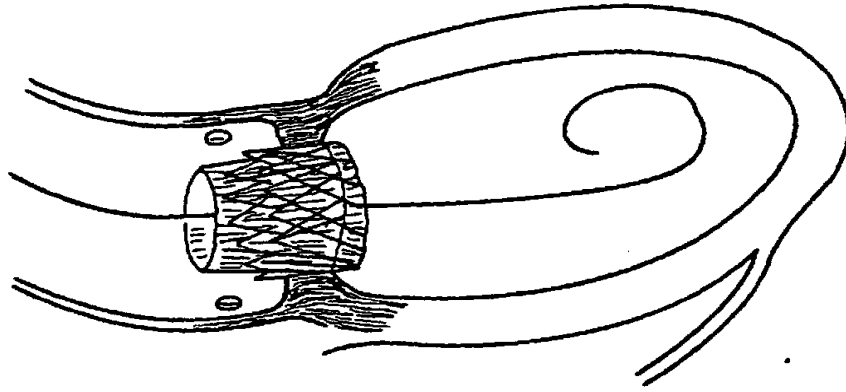


FIG. 13I

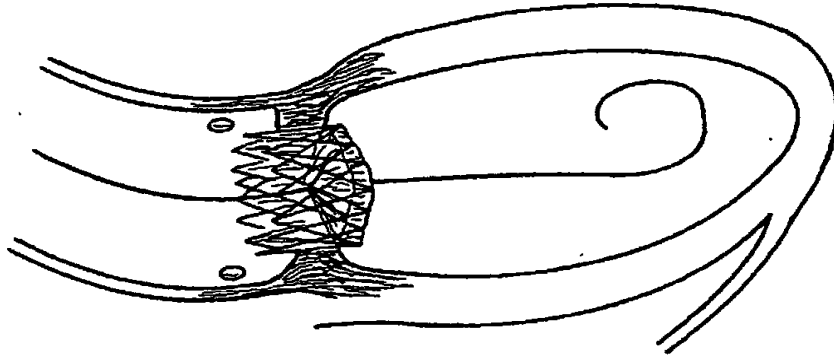


FIG. 13K

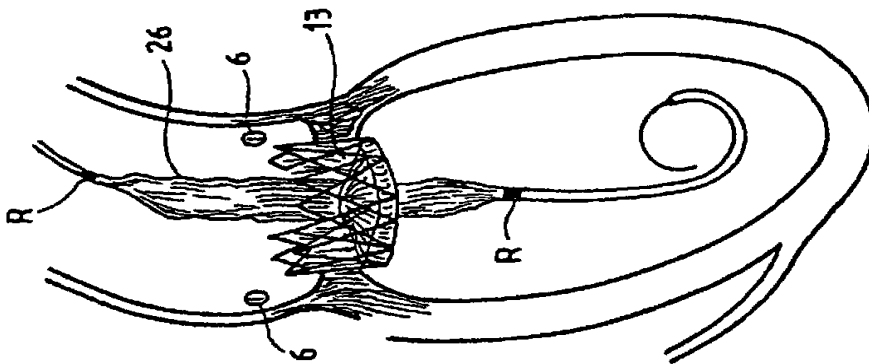
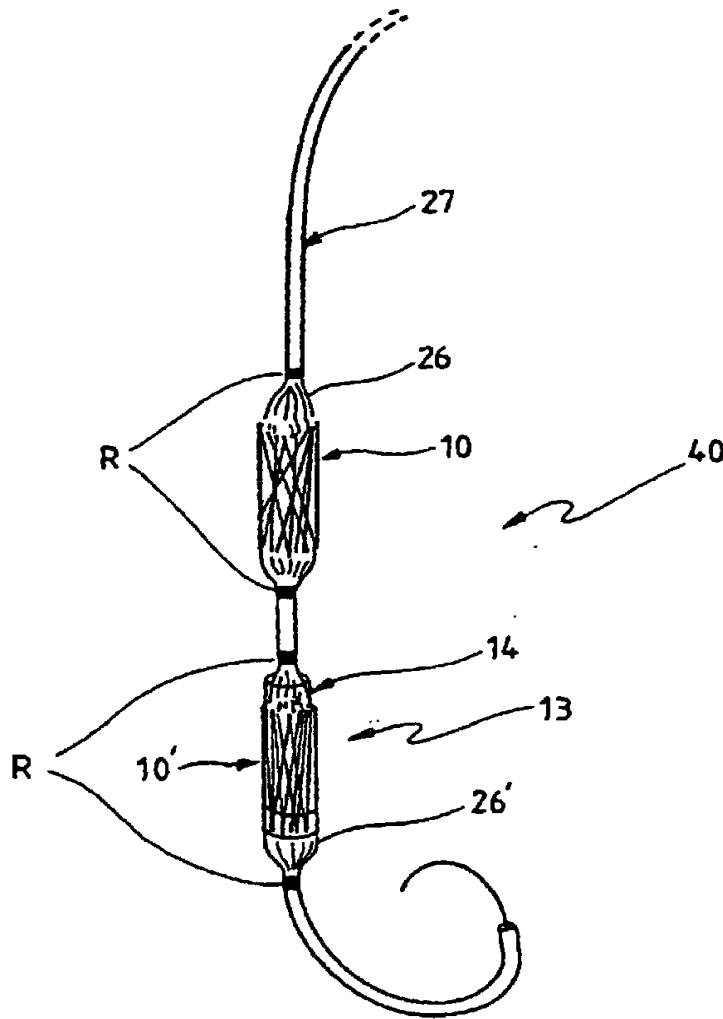


FIG. 13J

FIG\_14





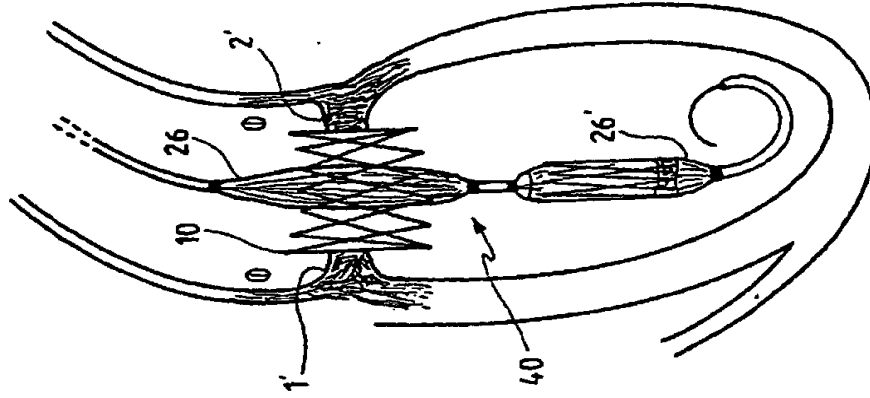


FIG. 15c

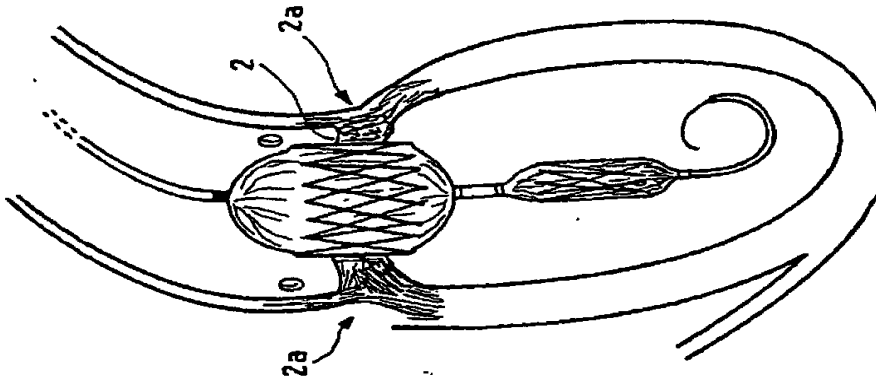


FIG. 15b

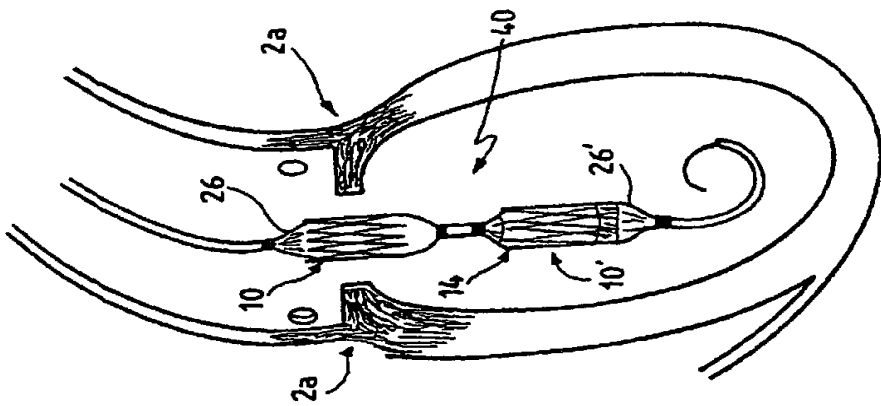


FIG. 15a

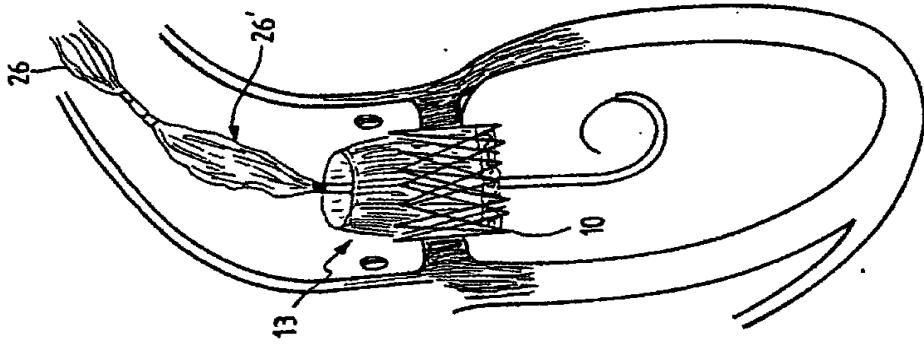


FIG. 15f

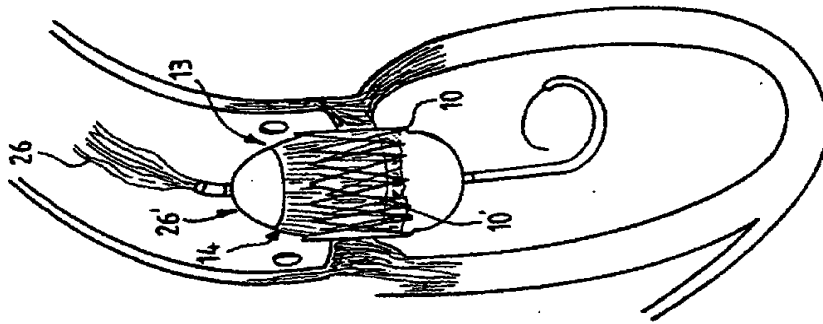


FIG. 15e

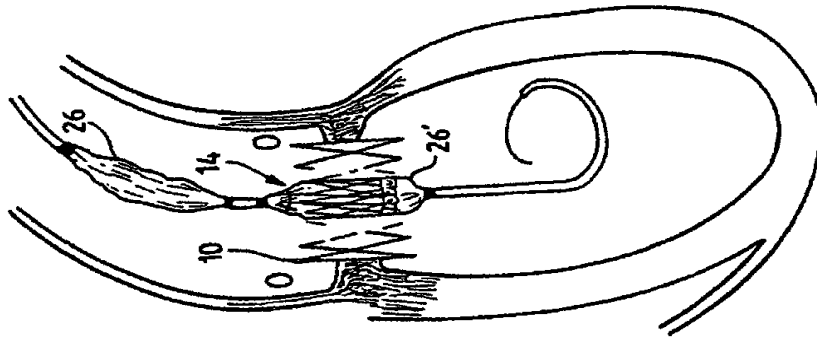


FIG. 15d

**REFERENCES CITED IN THE DESCRIPTION**

*This list of references cited by the applicant is for the reader's convenience only. It does not form part of the European patent document. Even though great care has been taken in compiling the references, errors or omissions cannot be excluded and the EPO disclaims all liability in this regard.*

**Patent documents cited in the description**

- US 5411552 A [0014]
- US 3657744 A [0017]

**Non-patent literature cited in the description**

- **M. D. DAKE.** *New Engl. J Med.*, 1994, vol. 331, 1729-34 [0103]



(11) **EP 2 055 266 B1**

(12) **EUROPEAN PATENT SPECIFICATION**

(45) Date of publication and mention of the grant of the patent:  
**15.02.2012 Bulletin 2012/07**

(51) Int Cl.:  
**A61F 2/24 (2006.01)**

(21) Application number: **08021823.3**

(22) Date of filing: **11.10.2002**

(54) **Implantable prosthetic valve**

Implantierbare prothetische Klappe  
Soupape prothétique implantable

(84) Designated Contracting States:  
**AT BE BG CH CY CZ DE DK EE ES FI FR GR IE IT LI LU MC NL PT SE SK TR**

(30) Priority: **11.10.2001 US 975750**

(43) Date of publication of application:  
**06.05.2009 Bulletin 2009/19**

(62) Document number(s) of the earlier application(s) in accordance with Art. 76 EPC:  
**02804403.0 / 1 441 672**

(73) Proprietor: **Edwards Lifesciences PVT, Inc. Irvine, CA 92614 (US)**

(72) Inventors:  
• **Spenser, Benjamin**  
**38900 Caesarea (IL)**  
• **Benichu, Netanel**  
**Hof-Carmel (IL)**  
• **Bash, Assaf**  
**37808 Givat Ada (IL)**  
• **Zakai, Avraham**  
**Zichon Yaacov (IL)**

(74) Representative: **Müller-Boré & Partner**  
**Patentanwälte**  
**Grafinger Straße 2**  
**81671 München (DE)**

(56) References cited:  
**WO-A1-01/56512 FR-A1- 2 815 844**

**EP 2 055 266 B1**

Note: Within nine months of the publication of the mention of the grant of the European patent in the European Patent Bulletin, any person may give notice to the European Patent Office of opposition to that patent, in accordance with the Implementing Regulations. Notice of opposition shall not be deemed to have been filed until the opposition fee has been paid. (Art. 99(1) European Patent Convention).

**Description**

## FIELD OF THE INVENTION

**[0001]** The present invention relates to a percutaneously implantable devices. More particularly, it relates to a valve prosthesis for cardiac implantation or for implantation in other body ducts.

## BACKGROUND OF THE INVENTION

**[0002]** There are several known prosthetic valves that have been previously described. U.S. Patent No. 5,411,552 (Andersen et al.), entitled VALVE PROSTHESIS FOR IMPLANTATION IN THE BODY AND CATHETER FOR IMPLANTING SUCH VALVE PROSTHESIS, discloses a valve prosthesis comprising a stent made from an expandable cylinder-shaped thread structure comprising several spaced apices. The elastically collapsible valve is mounted on the stent with the commissural points of the valve secured to the projecting apices, which prevents the valve from turning inside out. Deployment of the valve can be achieved by using an inflatable balloon which in its deflated state is used to carry about it the valve structure to its position and, when inflated, deploys the stent in position to its final size. See, also, U.S. Patent No. 6,168,614 (Andersen et al.) entitled VALVE PROSTHESIS FOR IMPLANTATION IN THE BODY and U.S. Patent No. 5,840,081 (Andersen et al.), entitled SYSTEM AND METHOD FOR IMPLANTING CARDIAC VALVES.

**[0003]** In PCT/EP97/07337 (Letac, Cribier et al.), published as WO 98/29057, entitled VALVE PROSTHESIS FOR IMPLANTATION IN BODY CHANNELS, there is disclosed a valve prosthesis comprising a collapsible valve structure and an expandable frame on which the valve structure is mounted. The valve structure is composed of a valvular tissue compatible with the human body and blood, the valvular tissue being sufficiently supple and resistant to allow the valve structure to be deformed from a closed state to an opened state. The valvular tissue forms a continuous surface and is provided with guiding means formed or incorporated within, the guiding means creating stiffened zones which induce the valve structure to follow a patterned movement in its expansion to its opened state and in its turning back to its closed state. The valve structure can be extended to an internal cover which is fastened to the lower part of the valve structure to prevent regurgitation.

**[0004]** There are several known methods currently used for replacing aortic valves and several types of artificial prosthetic devices. Mechanical valves are commonly used in several different designs (single and double flap) manufactured by well-known companies such as St. Jude, Medtronic, Sulzer, and others. Some of the main disadvantages of these devices are: a need for permanent treatment of anticoagulants, noisy operation, and a need for a large-scale operation to implant.

**[0005]** There is a wide range of biologically based valves made of natural valves or composed of biological materials such as pericardial tissue. These too are made and marketed by well-known companies such as Edwards Lifesciences, Medtronic, Sulzer, Sorin, and others.

**[0006]** Polymer valves are new and are not yet in use, but several companies are in the process of developing such products. A new type of prosthesis is being considered, based on artificial polymer materials such as polyurethane..

**[0007]** The present invention introduces several novel structural designs for implantable valves. An aspect of the present invention deals with the possibility of implanting the valve percutaneously, i.e., inserting the valve assembly on a delivery device similar to a catheter, then implanting the valve at the desired location via a large blood vessel such as the femoral artery, in a procedure similar to other known interventional cardiovascular procedures. The percutaneous deployment procedure and device has an impact on the product design in several parameters, some of which are explained hereinafter.

**[0008]** The percutaneous implantation of medical devices and particularly prosthetic valves is a preferred surgical procedure for it involves making a very small perforation in the patient's skin (usually in the groin or armpit area) under local anesthetic and sedation, as opposed to a large chest surgery incision, which requires general anesthesia, opening a large portion of the chest, and cardiopulmonary bypass. This percutaneous procedure is therefore considered safer.

**[0009]** Further, the French patent application FR 2 815 844 A1 discloses a valve assembly containing an collapsible and expandable support structure which comprises a proximal stent portion and a distal stent portion.

**[0010]** The present invention provides a series of new concepts in the field of aortic valves.

## SUMMARY OF THE INVENTION

**[0011]** A valve prosthesis device suitable for implantation in body ducts which is not part of the present invention, the device comprising:

a support stent, comprised of a deployable construction adapted to be initially crimped in a narrow configuration suitable for catheterization through the body duct to a target location and adapted to be deployed by exerting substantially radial forces from within by means of a deployment device to a deployed state in the target location, the support stent provided with a plurality of longitudinally rigid support beams of fixed length; and

a valve assembly comprising a flexible conduit having an inlet end and an outlet, made of pliant material attached to the support beams providing collapsible slack portions of the conduit at the outlet,

whereby when flow is allowed to pass through the valve prosthesis device from the inlet to the outlet the valve assembly is kept in an open position, whereas a reverse flow is prevented as the collapsible slack portions of the valve assembly collapse inwardly providing blockage to the reverse flow.

**[0012]** Furthermore, the support stent preferably comprises an annular frame.

**[0013]** Furthermore, said valve assembly preferably has a tricuspid configuration.

**[0014]** Furthermore, said valve assembly is preferably made from biocompatible material.

**[0015]** Furthermore, the valve assembly is preferably made from pericardial tissue, or other biological tissue.

**[0016]** Furthermore, said valve assembly is preferably made from biocompatible polymers.

**[0017]** Furthermore, the valve assembly is preferably made from materials selected from the group consisting of polyurethane and polyethylene terephthalate (PET).

**[0018]** Furthermore, said valve assembly preferably comprises a main body made from PET (polyethylene terephthalate) and leaflets made from polyurethane.

**[0019]** Furthermore, said support stent is preferably made from nickel titanium.

**[0020]** Furthermore, the support beams are preferably substantially equidistant and substantially parallel so as to provide anchorage for the valve assembly.

**[0021]** Furthermore, the support beams are preferably provided with bores so as to allow stitching or tying of the valve assembly to the beams.

**[0022]** Furthermore, the support beams are preferably chemically adhered to the support stent.

**[0023]** Furthermore, said valve assembly is preferably riveted to the support beams.

**[0024]** Furthermore, said valve assembly is preferably stitched to the support beams.

**[0025]** Furthermore, said beams are preferably manufactured by injection using a mold, or by machining.

**[0026]** Furthermore, said valve assembly is preferably rolled over the support stent at the inlet.

**[0027]** Furthermore, said valve device is preferably manufactured using forging or dipping techniques.

**[0028]** Furthermore, said valve assembly leaflets are preferably longer than needed to exactly close the outlet, thus when they are in the collapsed state substantial portions of the leaflets fall on each other creating better sealing.

**[0029]** Furthermore, said valve assembly is preferably made from coils of a polymer, coated by a coating layer of same polymer.

**[0030]** Furthermore, said polymer is preferably polyurethane.

**[0031]** Furthermore, the support stent is preferably provided with heavy metal markers so as to enable tracking and determining the valve device position and orientation.

**[0032]** Furthermore, the heavy metal markers are pref-

erably selected from gold, platinum, iridium, or tantalum.

**[0033]** Furthermore, the valve assembly leaflets are preferably provided with radio-opaque material at the outlet, so as to help tracking the valve device operation *in vivo*.

**[0034]** Furthermore, said radio-opaque material preferably comprises gold thread.

**[0035]** Furthermore, the diameter of said support stent, when fully deployed is preferably in the range of from about 19 to about 25 mm.

**[0036]** Furthermore, the diameter of said support stent may be expanded from about 4 to about 25 mm.

**[0037]** Furthermore, the support beams are preferably provide with bores and wherein the valve assembly is preferably attached to the support beams by means of U-shaped rigid members that are fastened to the valve assembly and that are provided with extruding portions that fit into matching bores on the support beams.

**[0038]** Furthermore, the support beams preferably comprise rigid support beams in the form of frame construction, and the valve assembly pliant material is preferably inserted through a gap in the frame and a fastening rod is preferably inserted through a pocket formed between the pliant material and the frame and holds the valve in position.

**[0039]** Furthermore, the main body of the valve assembly is preferably made from coiled wire coated with coating material.

**[0040]** Furthermore, the coiled wire and the coating material is preferably made from polyurethane.

**[0041]** Furthermore, a strengthening wire is preferably interlaced in the valve assembly at the outlet of the conduit so as to define a fault line about which the collapsible slack portion of the valve assembly may flap.

**[0042]** Furthermore, the strengthening wire is preferably made from nickel titanium alloy.

**[0043]** Furthermore, there is provided another valve prosthesis device suitable for implantation in body ducts which is not part of the present invention, the device comprising a main conduit body having an inlet and an outlet and pliant leaflets attached at the outlet so that when a flow passes through the conduit from the inlet to the outlet the leaflets are in an open position allowing the flow to exit the outlet, and when the flow is reversed the leaflets collapse so as to block the outlet, wherein the main body is made from PET and collapsible leaflets are made from polyurethane.

**[0044]** Furthermore, support beams made from polyurethane are preferably provided on the main body and wherein the leaflets are preferably attached to the main body at the support beams.

**[0045]** Furthermore, said support beams are preferably chemically adhered to the main body.

**[0046]** Furthermore, there is provided another valve prosthesis device suitable for implantation in body ducts which is not part of the present invention, the device comprising:

a support stent, comprised of a deployable construction adapted to be initially crimped in a narrow configuration suitable for catheterization through the body duct to a target location and adapted to be deployed by exerting substantially radial forces from within by means of a deployment device to a deployed state in the target location, the support stent provided with a plurality of longitudinally rigid support beams of fixed length;

a valve assembly comprising a flexible conduit having an inlet end and an outlet, made of pliant material attached to the support beams providing collapsible slack portions of the conduit at the outlet; and

substantially equidistant rigid support beams interlaced or attached to the slack portion of the valve assembly material, arranged longitudinally.

**[0047]** Furthermore, there is provided a crimping device for crimping a valve device described above which is not part of the present invention, the crimping device comprising a plurality of adjustable plates that resemble a typical SLR (Single Lens Reflex) camera variable restrictor, each provided with a blade, that are equally dispersed in a radial symmetry but each plate moves along a line passing off an opening in the center, all plates equidistant from that center opening.

**[0048]** Furthermore, the multiple plates are preferably adapted to move simultaneously by means of a lever and transmission.

**[0049]** Furthermore, there is provided a method for deploying an implantable prosthetic valve device from the retrograde approach (approaching the aortic valve from the descending aorta) or from the antegrade approach (approaching the aortic valve from the left ventricle after performing a trans-septal puncture) at the natural aortic valve position at the entrance to the left ventricle of a myocardium of a patient which is not part of the present invention, the method comprising the steps of:

(a) providing a balloon catheter having a proximal end and a distal end, having a first and second independently inflatable portions, the first inflatable portion located at the distal end of the catheter and the second inflatable portion adjacently behind the first inflatable portion;

(b) providing a guiding tool for guiding the balloon catheter in the vasculature of the patient;

(c) providing a deployable implantable valve prosthesis device adapted to be mounted on the second inflatable portion of the balloon catheter;

(d) for the retrograde approach, guiding the balloon catheter through the patient's aorta using the guiding tool, the valve device mounted over the second in-

flatable portion of the balloon catheter until the first inflatable portion of the balloon catheter is inserted into the left ventricle, whereas the second inflatable portion of the balloon catheter is positioned at the natural aortic valve position;

(e) for the antegrade approach, guiding the balloon catheter through the patient's greater veins, right atrium, left atrium, and left ventricle using the guiding tool, the valve device mounted over the second inflatable portion of the balloon catheter until the first inflatable portion of the balloon catheter is inserted into the left ventricle, whereas the second inflatable portion of the balloon catheter is positioned at the natural aortic valve position;

(f) inflating the first inflatable portion of the balloon catheter so as to substantially block blood flow through the natural aortic valve and anchor the distal end of the balloon catheter in position;

(g) inflating the second inflatable portion of the balloon catheter so as to deploy the implantable prosthetic valve device in position at the natural aortic valve position;

(h) deflating the first and second inflatable portions of the balloon catheter; and

(i) retracting the balloon catheter and removing it from the patient's body.

**[0050]** Furthermore, in accordance with another preferred embodiment of the present invention, the guiding tool comprises a guide wire.

**[0051]** Furthermore, there is provided another method for deploying an implantable prosthetic valve device at the natural aortic valve position at the entrance to the left ventricle of a myocardium of a patient which is not part of the present invention, the method comprising the steps of:

(a) providing a balloon catheter having a proximal end and a distal end, having a first and second independently inflatable portions, the first inflatable portion located at the distal end of the catheter and the second inflatable portion adjacently behind the first inflatable portion;

(b) providing a guiding tool for guiding the balloon catheter in the vasculature of the patient;

(c) providing a deployable implantable valve prosthesis device adapted to be mounted on the first inflatable portion of the balloon catheter, and a deployable annular stent device adapted to be mounted over the second inflatable portion of the balloon cath-

eter, the deployable implantable valve prosthesis device and the deployable annular stent kept at a predetermined distant apart;

(d) guiding the balloon catheter through the patient's aorta using the guiding tool, the valve device mounted over the first inflatable portion of the balloon catheter and the deployable annular stent mounted over the second inflatable portion of the balloon catheter, until the first inflatable portion of the balloon catheter is positioned at the natural aortic valve position;

(e) inflating the second inflatable portion of the balloon catheter so that the deployable stent device is deployed within the aorta thus anchoring the deployable annular stent and the coupled valve device in position;

(f) inflating the first inflatable portion of the balloon catheter so as to deploy the implantable prosthetic valve device in position at the natural aortic valve position;

(g) deflating the first and second inflatable portions of the balloon catheter, and

(h) retracting the balloon catheter and removing it from the patient's body.

**[0052]** Furthermore, a valve prosthesis device suitable for implantation in body ducts which is not part of the present invention comprises:

an expandable support frame, the support frame provided with a plurality of longitudinally rigid support beams of fixed length; and

a valve assembly comprising a flexible conduit having an inlet end and an outlet, made of pliant material attached to the support beams providing collapsible slack portions of the conduit at the outlet,

whereby when flow is allowed to pass through the valve prosthesis device from the inlet to the outlet the valve assembly is kept in an open position, whereas a reverse flow is prevented as the collapsible slack portions of the valve assembly collapse inwardly providing blockage to the reverse flow.

**[0053]** Furthermore, the support frame preferably comprises a deployable construction adapted to be initially crimped in a narrow configuration suitable for catheterization through the body duct to a target location and adapted to be deployed by exerting substantially radial forces from within by means of a deployment device to a deployed state in the target location.

**[0054]** Furthermore, the support beams preferably have a U-shaped cross section.

**[0055]** Furthermore, a holder is preferably used to secure the pliant material to the support beams

**[0056]** Furthermore, the support frame preferably comprises three segments that form a circular assembly when assembled.

**[0057]** Furthermore, the support beams preferably point inwardly with respect to a central longitudinal axis of the device.

**[0058]** Furthermore, the device is preferably further provided with a restricting tapered housing, for housing it in a crimped state.

**[0059]** Furthermore, hooks are preferably provided to secure the device in position after it is deployed.

**[0060]** Furthermore, the support beams preferably comprise longitudinal bars having a narrow slit used as the commissural attachment so that extensions the pliant material are tightly inserted through it.

**[0061]** Furthermore, extensions of the pliant material are preferably wrapped about rigid bars serving as anchorage means.

**[0062]** Furthermore, extensions of the pliant material are preferably sutured to each other at the rigid bars.

**[0063]** Furthermore, a bottom portion of the pliant material is preferably attached to the inlet.

**[0064]** Furthermore, the support beams are preferably each provided with a rounded pole, forming a loop through which the pliant material is inserted.

**[0065]** Furthermore, the pliant material is preferably provided with longitudinal bars attached to the pliant material at positions assigned for attachment to the support frame, in order to prevent localized stress from forming.

**[0066]** Furthermore, the device is preferably further provided with longitudinal bars having protrusions that are inserted in bores in the pliant material, a sheet of PET and through bores provided on the support beams.

**[0067]** Furthermore, pliant material is preferably sutured leaving the slack portions free of sutures.

**[0068]** Furthermore, a connecting member with a split portion is preferably used to connect leaflets of the pliant material to the support beams, the split connecting member compressing the pliant material in position.

**[0069]** Furthermore, a portion of the connecting member is preferably perpendicular to the split portion.

**[0070]** Furthermore, the support frame is preferably provided with metallic members coupled to the stent and rigid members are preferably positioned on two opposite sides of the metallic member and held against each other holding portion of the pliant material between them, sutured, the metallic members wrapped with PET.

**[0071]** Furthermore, the device is preferably further provided with spring in order to reduce wear of the pliant material.

**[0072]** Furthermore, the spring is preferably provided with a spiral.

**[0073]** Furthermore, the spring is preferably made from stainless steel.

**[0074]** Furthermore, the spring is preferably attached to slots provided on the support frames.



**[0075]** Furthermore, the pliant material is preferably sutured to the support frame forming pockets.

**[0076]** Furthermore, attachment bars are preferably provided on the stent support at a portion of the stent close to the outlet, onto which the pliant material is coupled, and wherein the pliant material is preferably attached circumferentially to the inlet, leaving slack pliant material.

**[0077]** Furthermore, the outlet is preferably tapered with respect to the inlet.

**[0078]** Furthermore, the support frame at the outlet is preferably wider in diameter than the pliant material forming the outlet

**[0079]** Furthermore, the pliant material is preferably reinforced using PET.

**[0080]** Furthermore, the support frame is preferably a tube having an inner wall, having sinusoidal fold lines, wherein the pliant material is preferably sutured having an inner wall, along suture fold lines,

**[0081]** Furthermore, additional piece of PET is preferably added below the suture lines.

**[0082]** Furthermore, the device is preferably incorporated with an angioplasty balloon.

**[0083]** Further, the balloon preferably has a central longitudinal axis that runs along a flow path through the device, and a perimeter, the balloon preferably comprising four inflatable portions, one portion located along a central axis and the other three located on the perimeter, the pliant material in the form of leaflets is preferably distributed about the perimeter.

**[0084]** Furthermore, a percutaneously implantable prosthetic device for replacing a deficient native aortic valve according to the present invention, comprises:

- a collapsible and expandable support stent formed of a shape memory alloy, the support stent adapted to be initially crimped into a narrow configuration suitable for catheterization through a body duct to a target location,

- the support stent comprising, a proximal stent portion configured to expand to a first diameter and

- a distal stent portion configured to expand to a second diameter, the first diameter being smaller than the second diameter for preventing deformation of the mitral valve by over expansion and for providing a difference between the support stent and aortic root so that the openings of the coronary arteries will not be blocked; and

- a collapsible and expandable valve assembly having leaflets formed of pericardial tissue,

whereby the valve assembly is attached to the support stent and has an open position suitable to allow blood to pass from an inlet to an outlet of the valve assembly and has a closed position suitable to provide blockage to a

reverse flow;

wherein the first diameter of the support stent is sized for direct engagement with the leaflets of the native aortic valve and the second diameter of the support stent is sized for direct engagement with the inner wall of the ascending aorta, and

wherein the stent is sized to avoid a contact with the inner wall of a left ventricle when implanted.

**[0085]** Preferably, the valve assembly is provided in the proximal stent portion.

**[0086]** Preferably, the shape memory alloy is nickel titanium.

**[0087]** Preferably, the support stent is collapsible to a delivery diameter sized for advancement through a femoral artery, wherein the delivery diameter is preferably less than 8 mm.

**[0088]** Preferably, the first diameter of the support stent is in the range of about 19 mm to 25 mm.

**[0089]** Preferably, the valve assembly is sewed to the support stent.

**[0090]** Preferably, the valve assembly has a tricuspid valve configuration.

**[0091]** Preferably, the support stent has an annular shape.

**[0092]** Preferably, the valve assembly is contained within the proximal stent portion.

**[0093]** Preferably, the second diameter of the distal stent portion is sized for decreasing the risk of device migration.

#### BRIEF DESCRIPTION OF THE FIGURES

**[0094]** To better understand the present invention and appreciate its practical applications, the following Figures are provided and referenced hereafter. It should be noted that the Figures are given as examples only and in no way limit the scope of the invention as defined in the appended claims.

Figure 1 illustrates an implantable prosthetic tricuspid valve suitable for percutaneous deployment using a stent or similar deploying means, in its deployed-inflated position;

Figure 2 depicts an implantable valve mounted over a deploying stent with an inflatable balloon;

Figure 3 illustrates an implantable valve mounted over a stent with an inflatable balloon, in a crimped position;

Figure 4 depicts implantable valve deployment in a natural aortic valve position;

Figure 5 demonstrates manufacturing a polyurethane implantable valve using a dipping technique;

Figures 6a to 6e illustrate manufacturing of an implantable valve by forging;

Figures 7a and 7b demonstrate composite valve, which has polyurethane (PU) leaflets and PET tubular-crown shaped construction;

Figures 8a and 8b depict a manufacture process of a composite valve made of flexible PU leaflets, rigid PU construction for mounting and a PET tubular end;

Figures 9 to 9i demonstrate different methods of attachment between the valve and stent;

Figure 10 illustrates a dipping mandrel with an extra portion, which improves the sealing ability of the valve;

Figures 11a to 11c illustrate a valve mounted on a stent with an extra support, which improves the force distribution on the valve material and facilitates prolonged durability of the valve;

Figures 12a to 12c depict a valve with rigid supports located substantially in the center of its leaflets. This design allows the valve leaflets to perform without outer support;

Figures 13a to 13c illustrate the manufacturing of a reinforced PU tube composed of strong fiber from PU, PET or other and a softer PU coating, for serving as the supporting structure;

Figures 14a to 14c demonstrate incorporation of heavy metal markers on the stent. These markers allow orientation control while positioning the device at the required location;

Figures 15a to 15c demonstrate a valve with radio-opaque coating, which allows imaging of the valve motion under angiogram;

Figures 16a to 16c illustrate a procedure, which helps in accurate positioning the valve device with respect to the longitudinal orientation;

Figures 17a and 17b describe a valve device according to the present invention, comprising one valve assembly mounted on a stent and an additional portion with a stent only. This allows placing the device in a way that coronaries are not blocked, longitudinal positioning thus becomes less sensitive and the extra stent decreases the risk of device migration within the vasculature;

Figures 18a and 18b demonstrate a crimping device, which can crimp a valve device in the operating theater as part of the implantation procedure;

Figures 19a to 19c depict a crimping machine, similar to the one described in figure 18 with a different mechanical method;

Figures 20a and 20b demonstrate a valve, made of a tube mounted on a stent. During systole the tube is fully open and during diastole the tube collapses according to the mounting geometry providing tight sealing;

Figure 21 depicts a stent structure, with built-in mounting portions of constant length, which allow valve mounting;

Figure 22 depicts another valve assembly having dilated supports;

Figures 23a to 23e depict stages in a method of manufacturing an implantable prosthetic valve;

Figures 24a to 24c illustrate a support frame of an implantable prosthetic valve having means for mounting valve leaflets that can form a tricuspid valve. Figure 24a depicts an isometric view of the frame, and Figure 24b depicts a cross-sectional view of the means for mounting a valve leaflet in details, provided with a valve leaflet Figure 24c depicts further details of attachment means for the attachment method;

Figures 25a to 25d illustrate an implantable prosthetic valve. Figures 25a and 25b depict an isometric view and an upper view of the valve assembly, respectively, and Figures 25c and 25d illustrate upper views of two optional constructions for the means for mounting leaflets;

Figures 26a to 26c illustrate a tricuspid valve provided with a self-expandable frame. Figure 26a is the valve in its fully expanded diameter, Figure 26b is a tapered tool which assists in inserting the valve into an introducing tube, and Figure 26c shows the valve assembly inside a restriction tube, ready to be inserted into a introducing sheath;

Figure 27 illustrates an isometric view of an implantable prosthetic valve having hooks designated to anchor the valve assembly to body ducts;

Figure 28 illustrates a partial view of an implantable prosthetic valve. The commissural attachment is showed in details;

Figures 29a and 29b illustrate an isometric view and an upper cross-sectional view, respectively, of an attachment assembly of a valve's frame to leaflets;

Figures 30a to 30c illustrates an isometric view, a

cross-sectional view and a flattened view, respectively, of an attachment assembly of a valves frame to leaflets. Figure 30c is a side view showing two pieces of pericardium before the attachment to the frame;

Figures 31a and 31b illustrate an exploded view and an isometric view, respectively, of a commissural attachment depicting the attachment technique;

Figures 32a and 32b illustrate an isometric view of an attachment between leaflets and the frame;

Figures 33a to 33d illustrate different views and portions of an attachment between a pericardium and a frame, demonstrating another method of attachment;

Figures 34a to 34c illustrate an isometric view of an attachment between a pericardium and a valve demonstrating another method of attachment. In Figures 34b and 34c, a deployed portion and the folded portion, respectively, are shown;

Figures 35a to 35d illustrate an isometric and cross-sectional upper views, respectively, of attachment techniques between a pericardium leaflet and a valve's frame;

Figures 36a and 36b illustrate an isometric view of a commissural assembly demonstrating a method of forming one;

Figures 37a to 37c illustrates a commissural assembly, where the connecting bar functions as a flexible support and has integral attachment means to the frame. Figure 37b is an isometric view of the connecting bar;

Figures 38a to 38g illustrate isometric views of flexible commissural supports and the method of attaching them to a pericardium and a frame and valve;

Figures 39a to 39b illustrate an isometric view of a commissural attachment, demonstrating the attachment of the pericardium to the support by means of a shaped compressing member;

Figures 40a to 40c illustrate an isometric view of a bicuspid valve mounted on a frame. Figures 40b and 40c depicts a cross-sectional side view and an isometric view, respectively, of the pericardium that is sutured to a PET tube in the form of pockets;

Figures 41a to 41d illustrate isometric views of an implantable prosthesis tricuspid valve;

Figures 42a and 42b illustrate an isometric view of

an implantable prosthetic valve having a different commissural attachment Figure 42b depicts the attachment in details;

5 Figures 43a and 43b illustrate an isometric view of an implantable prosthetic valve. Figure 43a depicts the commissure that are pre-sutured in a tapered shape;

10 Figures 44a to 44c illustrate an isometric view of an implantable prosthetic valve with additional pieces of PET used for sealing and protecting the pericardium;

15 Figures 45a to 45d illustrate an isometric view of an implantable prosthetic valve having leaflets sutured to a pre-shaped PET tube and optional leaflet-tube attachments in details;

20 Figures 46a and 46b illustrate an exploded view and an upper cross-sectional view of an implantable prosthetic valve assembly;

25 Figures 47a to 47c illustrate a partial cross-sectional side view of an inflating balloon. The balloon is a part of an implantable prosthetic valve delivery system. Figures 47b and 47c are cross sectional upper views in the inflated and deflated positions, respectively; and

30 Figures 48a and 48b illustrate a partial cross-sectional side view and an upper cross-sectional view of an inflating balloon.

### 35 DETAILED DESCRIPTION OF THE INVENTION

**[0095]** A main aspect of the present invention is the introduction of several novel designs for an implantable prosthetic valve.

40 **[0096]** Basically the implantable prosthetic valve of the present invention comprises a leafed-valve assembly, preferably tricuspid but not limited to tricuspid valves only, consisting of a conduit having an inlet end and an outlet, made of pliant material arranged so as to present collapsible walls at the outlet. The valve assembly is mounted on as support structure such as a stent adapted to be positioned at a target location within the body duct and deploy the valve assembly by the use of deploying means, such as a balloon catheter or similar devices. In  
50 embodiments suitable for safe and convenient percutaneous positioning and deployment the annular frame is able to be posed in two positions, a crimped position where the conduit passage cross-section presented is small so as to permit advancing the device towards its  
55 target location, and a deployed position where the frame is radial extended by forces exerted from within (by deploying means) so as to provide support against the body duct wall, secure the valve in position and open itself so

as to allow flow through the conduit.

**[0097]** The valve assembly can be made from biological matter, such as a natural tissue, pericardial tissue or other biological tissue. Alternatively, the valve assembly may be made from biocompatible polymers or similar materials. Homograph biological valves need occasional replacement (usually within 5 to 14 years), and this is a consideration the surgeon must take into account when selecting the proper valve implant according to the patient type. Mechanical valves, which have better durability qualities, carry the associated risk of long-term anticoagulation treatment.

**[0098]** The frame can be made from shape memory alloys such as nickel titanium (nickel titanium shape memory alloys, or NiTi, as marketed, for example, under the brand name Nitinol), or other biocompatible metals. The percutaneously implantable embodiment of the implantable valve of the present invention has to be suitable for crimping into a narrow configuration for positioning and expandable to a wider, deployed configuration so as to anchor in position in the desired target location.

**[0099]** The support stent is preferably annular, but may be provided in other shapes too, depending on the cross-section shape of the desired target location passage.

**[0100]** Manufacturing of the implantable prosthetic valve can be done in various methods, by using pericardium or, for example, by using artificial materials made by dipping, injection, electrospinning, rotation, ironing, or pressing.

**[0101]** The attachment of the valve assembly to the support stent can be accomplished in several ways, such as by sewing it to several anchoring points on the support frame or stent, or riveting it, pinning it, adhering it, or welding it, to provide a valve assembly that is cast or molded over the support frame or stent, or use any other suitable way of attachment.

**[0102]** To prevent leakage from the inlet it is optionally possible to roll up some slack wall of the inlet over the edge of the frame so as to present rolled-up sleeve-like portion at the inlet.

**[0103]** Furthermore, floating supports may be added to enhance the stability of the device and prevent it from turning inside out.

**[0104]** An important aspect of certain examples is the provision of rigid support beams incorporated with the support stent that retains its longitudinal dimension while the entire support stent may be longitudinally or laterally extended.

**[0105]** Different designs and different types of devices are discussed and explained below with reference to the accompanying drawings. Note that the drawings are only given for the purpose of understanding the present invention and presenting some preferred embodiments of the present invention, but this does in no way limit the scope of the present invention as defined in the appended claims.

**[0106]** Reference is now made to Figure 1, which illustrates a general tricuspid implantable prosthetic valve 20

suitable for percutaneous deployment using an expandable stent or similar deploying means, shown in its deployed position. A valve assembly 28 comprises a conduit having an inlet 24 and an outlet 26, the outlet walls consisting of collapsible pliant material 29 that is arranged to collapse in a tricuspid arrangement. The valve assembly 28 is attached to an annular support stent 22, the one in this figure being at net-like frame designed to be adapted to crimp evenly so as to present a narrow configuration and be radially deployable so as to extend to occupy the passage at the target location for implantation in a body duct. Support beams 23 are provided on annular support stent 22 to provide anchorage to valve assembly 28. Support beams 23 are optionally provided with bores 25 to allow stitching of valve assembly 28 to support beams 23 by thread, wires, or other attachment means.

**[0107]** In the example shown in Figure 1, a cuff portion 21 of the valve assembly 28 is wrapped around support stent 22 at inlet 24 to enhance the stability. Preferably cuff portion 21 of valve material 28 is attached to support beams 23.

**[0108]** Note that the entire valve structure is adapted to be radially crimped and radially expanded, and this lends to provide ease of navigation through narrow passages in the vasculature during positioning of the device and adequate deployment on the final location. This is made possible by the provision of a collapsible support stent structure. However, the support beams remain at all times constant at their length and thus are suitable for serving as the pliable valve assembly's anchorage. The valve assembly is attached to the support stent at the support beams, and due to their constant length there is no need for slack material as the attachment points (25) remain at constant distances regardless of the position of the valve device (crimped or deployed). This is an important feature for this means that the manufacturer of the valve device can make sure the valve assembly is secured and fastened to the support stent at all times. In prior art implantable valve devices the entire support structure changes its dimensions from its initial first crimped position and final deployed position, and this means that in the attachment of the valve assembly to the support structure one must take into consideration these dimension changes and leave slack material so that upon deployment of the device the valve assembly does not tear or deform. In the valve device there is no relative movement between the valve assembly and the support beams (along the longitudinal central axis of the device). As a result, the valve device acquires greater durability and is capable of withstanding the harsh conditions prevailing within the vasculature and especially the millions of cycles of stress applied by the blood pressure.

**[0109]** The fixed attachment of the valve assembly to the support stent in the valve device results in greater stability, enhanced safety, better sealing and consequently longer lifespan. The design of the valve device

leads to longitudinal strength and rigidity whereas its collapsible support structure results in radial flexibility.

**[0110]** Figure 2 depicts an implantable valve 30 mounted on a deployable stent 32. The valve assembly 34 is attached to the deployable support stent 32 (dotted lines) along three substantially equidistant and substantially parallel support beams 40 of constant length, which are part of stent 32. The attachment of valve assembly 34 to stent 32 is facilitated by the support beams 40 to which valve assembly 34 is stitched with thread or fiber 46 (through bores 42 of support beams 40). Outlet leaflets 38, which are a slack portion of the valve assembly, dangle inwardly, and the whole device is carried by an inflatable balloon 48, which serves as the deploying device. A portion of the valve assembly 34 at an inlet zone 45 is optionally rolled over support stent 32 at the inlet, making up a rolled sleeve, which enhances the sealing of the device at the valve inlet.

**[0111]** Figure 3 demonstrates an implantable valve mounted to a stent 50 with an inflatable balloon 52, in a crimped position. The support stent 50 is initially crimped about the balloon 52 so that it presents a narrow cross-section and is thus suitable for percutaneous catheterization and deployment.

**[0112]** Figure 4 depicts an implantable valve deployment in a natural aortic valve position. The implantable valve is advanced while mounted over the balloon 52 until it reaches the desired target location 54 in a body duct, for example, aorta 56. The balloon is inflated and the support stent 50 expands radially to take up its position.

**[0113]** Figure 5 demonstrates the manufacture of a polyurethane valve in a dipping technique. A dipping mandrel 60 is provided with a tubular portion 62 with surfaces 64 that correspond to the collapsible valve leaflets to be manufactured. Mandrel 60 is dipped into a dissolved polyurethane bath 66 and is coated with a polyurethane coating in the desired form of the valve. Then, after the polyurethane coating has hardened sufficiently, the completed valve is removed from mandrel 60.

**[0114]** Figures 6a to 6e illustrate manufacturing an implantable valve by forging. A suitable tubularly shaped material 74 is placed tightly on a tubular portion 68 of mandrel 67, covering the cusp portion 69. Flexible inserts 76 are pressed to mandrel 67, forging the tubular material to mandrel shape 80. A tapered ring 70 holds the flexible inserts in place as the whole mold is placed in a hot oven regulated to a desired temperature, which is lower than the material's melting point. Figure 6e illustrates a sectional side view of the mandrel and a cross cut portion of the mold. The mold is made to press inwardly on the mandrel, which is covered with the valve material. As a result the material takes up the desired shape. The materials used can vary, for example, polyurethane (PU), polyethylene terephthalate (PET), or any other suitable material, which may be formed by heating.

**[0115]** Figures 7a and 7b demonstrate a method of manufacturing a composite valve, which has PU leaflets

and PET tubular construction with a crown shape. PU is an excellent fatigue resistant material but is sensitive to tear. The PU is reinforced by the PET crown to allow safe attachment to a stent by means of stitching, riveting, or any other suitable attachment method. A PET crown 86 is placed on a mandrel 87, which is then (turned and) dipped in a container of dissolved PU. The manufactured device is a valve assembly having leaflets 88 composed of pure PU, and thus fatigue resistant, and a main body made of PET with protruding attachment portions 90 suitable for attachment built in the PU.

**[0116]** Figures 8a and 8b demonstrate a method of manufacturing a composite valve, which is based on flexible PU 92 for as the main body of the valve, rigid PU support beams 94 serving for the attachment area, and PET sleeve 96 portions for the valve inlet. The need for a rigid portion for attachment (support beams 94) is explained by the tendency of the flexible, fatigue resistant material to tear as already explained. The advantage of the stiff PU support beams is that they are chemically adhered to the main body, and this improves the overall durability of the valve due to reduction of inner forces and friction in the attachment area specially attachment between two different materials. The valve is dipped in the method mentioned with reference to Figure 5, and the rigid PU support beam 94 is created by way of mold injection, machining or any other suitable way. The rigid PU support beam 94 is placed on the valve and then dipped into the container of dissolved PU. This is done while the valve is positioned on the mandrel (not shown). This method provides the ability to composite several materials into one body and, by that, gain the advantage of the various properties of the materials as they are needed in different areas of the prosthesis.

**[0117]** Figures 9 to 9i demonstrate different methods of attachment between a valve assembly and the support stents. A valve assembly 99 shown in Fig. 9 is incorporated into valve 100 shown in Fig. 9a, where a support stent 102 is attached to valve assembly 99 through support beam 106. A detail is shown in Fig. 9b, where, in cross-section, it can be seen that layer 108 is an optional inner support made of stainless steel or rigid polymeric material, valve assembly 99 comprises a PET layer 105 coated with a PU layer 104, with the outer support beam 106. Connector 107 is a connecting wire made of a strong material, such as stainless steel. Figure 9c illustrates an alternative arrangement for attachment by a rivet 109, and in Figure 9d the attachment is achieved by a suture 110.

**[0118]** Figures 9e to 9g show an attachment method comprising shaped rigid members 116, preferably made from metal, which tightly hold the PU valve material 118 by fitting in between a PU U-shaped nest 120 and are attached to a stent 122 by extruding portions 124 that are provided on U-shaped rigid member 116, which fit the bores 126 of the support beam 128 of the stent 122. Figures 9h and 9i show another attachment method, where rigid support beams in the form of frame construc-

tion 132 are provided, and the valve assembly pliant material 135 made of a tubular material is inserted through a gap 137 in the frame. After insertion, a fastening rod 133 is inserted through the pocket formed between the pliant material and the frame and holds the valve in position.

**[0119]** Figure 10 illustrates a dipping mandrel 139 with an extending portion 141, which improves the sealing ability of the valve. Since the valve is attached to a collapsible stent and is itself collapsible, it is difficult to determine the exact shape of the valve after crimping and deploying. It is of major importance that sealing will be achieved. By adding the extension 141 the leaflets are made longer than needed to exactly close the outlet, and therefore when they are in the collapsed state, substantial portions of the leaflets fall on each other creating better sealing.

**[0120]** Figures 11a to 11c illustrate a valve assembly mounted on a support stent 144 with interlaced strengthening wire 146, which improves the force distribution on the valve material and facilitates prolonged durability of the valve. The support is in the form of a wire, which has a crown shape as the shape of the three cusp valve base 148, it also has the ability to be crimped 150 to a small diameter, together with the stent, valve and balloon, as shown in Fig. 11b: The forces applied to the valve edge 148 while working, are applied to the attachment points, by making the attachment line longer we reduce the force on each attachment point. In this support method the valve is attached by suturing 152 the entire line to the extra support wire 146. This wire can be made of stainless steel, nickel titanium alloy such as nitinol, or polymeric material. The support suture renders the valve assembly default fault lines where the valve material more readily flexes, thus ensuring proper operation of the valve flaps (leaflets). Optionally the valve assembly shown in Figures 11a to 11c can be mounted on a support stent such as the one described herein or similar supporting structures. The strengthening wire is interlaced in the valve assembly at the outlet of the conduit so as to define a fault line about which the collapsible slack portion 154 of the valve assembly may flap.

**[0121]** Figures 12a to 12c depict a valve device provided with a stent 159 and substantially equidistant rigid support beams 160, interlaced or attached to the slack portion of the valve assembly material 161, arranged longitudinally. This design allows the valve leaflets to perform without outer support. The support in standard valves is by tying the upper edge of the cusp to a rigid embodiment, so that it reacts to the load as a suspension bridge. In this new design the prevention of collapsing is achieved similar to an Indian tent, i.e., the rigid supports lean on each other 162 when the valve is closed but do not interfere in opening 164 when the valve is open.

**[0122]** Figures 13a to 13c illustrate the manufacturing of a valve assembly. At first a polyurethane thread line 170 is fed from a PU supply 172, and coiled around a cylindrical drum 174 to form coil 176. Then, drum 174

with coil 176 is dipped in a PU bath 177, and a second layer 178 of the PU coats coil 176, making it a stronger construction capable of withstanding tearing forces both laterally and in other directions. Incorporating two different types of materials - such as PU and PET - may render greater durability and endurance to the valve assembly. This material is an alternative material to be used in the forging method shown in Figure 6.

**[0123]** Figures 14 to 14c demonstrate the incorporation of heavy metal markers on the stent, which markers allow observation and thereby adjustment of orientation while placing the device in the required location. Heavy metals are radiopaque, that is, they are conspicuous on an angioscopic image, which is a two-dimensional image. Since the coronary artery ostia 237 and 238 are located near the typical valve deployment location and must stay open, it is extremely important to make sure that the deployed valve assembly is not blocking a coronary ostium. In some cases the stent is lower than the ostium and in those cases it will stay open, but in some cases as shown in these figures it is necessary to make sure that the stent portion 239 that is connecting the valve supports 235 is opposite the coronary ostia, and in that way the blood supply is preserved through the stent struts. Two heavy metal markers 232 are attached at the outlet side, one marker 230 at the inlet side. It is possible to adjust the angioscopic view to the plane of the left coronary as shown in Figure 14b and anatomically locate the other accordingly. If the two upper markers 232 are placed in the radiographic two dimensional image, one on top of the other, and the low marker 230 on the opposite side, we make sure that the coronaries are open to blood flow as seen in Figure 14c. Gold, platinum, iridium or tantalum are all biocompatible materials suitable for the markers described above.

**[0124]** Figures 15a to 15c illustrate a valve with a portion of radio-opaque material 267 such as a thread of gold at the sealing edge. When a valve is implanted, it is very important to have clear indications of how the valve is functioning *in vivo*; pressure measurements, flow visualization, and doppler measurements are utilized. It is also possible to examine the valve by ultrasound methods, however, observing the opening and closing of the valve cusps on a monitor. Fig. 15b is an angiographic image 268 of the open valve, while image 169 in Figure 15c is the closed position as seen on the angiogram.

**[0125]** Figures 16a to 16c illustrate a procedure, which helps in placing the device in the longitudinal position. It is very important to place the device in the correct longitudinal position, for if it is too deep in the left ventricle it may interfere with the mitral valve function by improper closing or function of the valve. If it is positioned too high it may migrate, it may leak via the sinus cavities, which are located around it, and/or it may block the coronaries. It is a necessary task to position the valve prosthesis in a narrow target location. In Figure 14 a method of lateral orientation placement is shown, and Figures 16a to 16c illustrate a longitudinal positioning. The valve device (the

valve assembly and the support stent) is placed on an inflatable balloon catheter, comprising double independently inflatable chambers 303, 305, and is inserted into the left ventricle 302 in the crimped position and guided over a guiding stylet or guide wire 300. The balloon, which is larger than the annulus diameter when inflated, is inflated in the left ventricle 302, and then the whole device is pulled slightly backwards. The balloon is supported on the inner part of the annulus 303, allowing positioning of the device in the exact desired position. In addition, it temporarily blocks the blood flow, and that improves the ability to hold the device in place while inflating it. The next step is inflating the second balloon 305, which deploys the valve device in the desired location.

**[0126]** The method for deploying an implantable prosthetic valve device at the natural aortic valve position at the entrance to the left ventricle of a myocardium of a patient, as depicted in Figures 16a, 16b and 16c, comprises the steps of:

(a) providing a balloon catheter having a proximal end and a distal end, having a first and second independently inflatable portions, the first inflatable portion located at the distal end of the catheter and the second inflatable portion adjacently behind the first inflatable portion;

(b) providing a guiding tool for guiding the balloon catheter in the vasculature of the patient;

(c) providing a deployable implantable valve prosthesis device adapted to be mounted on the second inflatable portion of the balloon catheter

(d) guiding the balloon catheter through the patient's aorta using the guiding tool, the valve device mounted over the second inflatable portion of the balloon catheter until the first inflatable portion of the balloon catheter is inserted into the left ventricle, whereas the second inflatable portion of the balloon catheter is positioned at the natural aortic valve position;

(e) inflating the first inflatable portion of the balloon catheter so as to substantially block blood flow through the natural aortic valve and anchor the distal end of the balloon catheter in position;

(f) inflating the second inflatable portion of the balloon catheter so as to deploy the implantable prosthetic valve device in position at the natural aortic valve position;

(g) deflating the first and second inflatable portions of the balloon catheter; and

(h) retracting the balloon catheter and removing it from the patient's body.

**[0127]** Figure 17 describes a positioning of a valve device 310 using an additional deployable stent 320. There are several problems that may be encountered while deploying the stent and valve in the aortic valve location: blockage of coronaries may occur that is dangerous if the diameter of the stent is similar to that of the coronaries aortic root 309. Secondly, migration of the whole device may also occur, which is a dangerous possibility, and there is the problematic challenge of exact positioning of the valve device that is very difficult to accomplish, as already explained. The newly special designed device with a double diameter inflatable balloon and double stent design allows placement of the device in a way that coronaries will not be blocked because of a safe difference that is kept between the diameters, longitudinal placing is less sensitive because of the small diameter which ensures prevents over expansion of the valved prosthesis. The distal stent 320, which contains no valve, is expanded into the ascending aorta, while the proximal stent 310 is placed simultaneously in the annular position. This placement method is less challenging due to the smaller diameter of the proximal stent 310 which ensures that the mitral valve is not deformed by over-expansion as the dimensions are preserved, and the additional stent decreases the risk of device migration. It is safer to over dilate in the aorta, which is not true for the annulus.

**[0128]** The method for deploying an implantable prosthetic valve device at the natural aortic valve position at the entrance to the left ventricle of a myocardium of a patient, as depicted in Figures 17a and 17b, comprises the steps of:

(a) providing a balloon catheter having a proximal end and a distal end, having a first and second independently inflatable portions, the first inflatable portion located at the distal end of the catheter and the second inflatable portion adjacently behind the first inflatable portion;

(b) providing a guiding tool for guiding the balloon catheter in the vasculature of the patient;

(c) providing a deployable implantable valve prosthesis device adapted to be mounted on the first inflatable portion of the balloon catheter, and a deployable annular stent device adapted to be mounted over the second inflatable portion of the balloon catheter, the deployable implantable valve prosthesis device and the deployable annular stent kept at a predetermined distant apart;

(d) guiding the balloon catheter through the patient's aorta using the guiding tool, the valve device mounted over the first inflatable portion of the balloon catheter and the deployable annular stent mounted over the second inflatable portion of the balloon catheter, until the first inflatable portion of the balloon catheter is positioned at the natural aortic valve position;

(e) inflating the second inflatable portion of the balloon catheter so that the deployable stent device is deployed within the aorta thus anchoring the deployable annular stent and the coupled valve device in position;

(f) inflating the first inflatable portion of the balloon catheter so as to deploy the implantable prosthetic valve device in position at the natural aortic valve position;

(g) deflating the first and second inflatable portions of the balloon catheter; and

(h) retracting the balloon catheter and removing it from the patient's body.

**[0129]** Figures 18a and 18b illustrate an accessory crimping device that is adapted to crimp a valve device in the operating theater as part of the implantation procedure. The crimping device 330 comprises several adjustable plates that resemble a typical SLR camera variable restrictor. It is comprised of simultaneously movable plates 332 each provided with a blade 334, that are equally dispersed in a radial symmetry but each plate moves along a line passing off an opening in the center, all plates equidistant from that center opening 336. Initially (see Figure 18a) the plates are drawn apart providing a large enough opening for the implantable valve to be positioned within that opening. When the plates are drawn towards the center (see Figure 18b), the opening 336 reduces in size but still retains the annular shape, and this facilitates the crimping of the valve frame to a small dimension suitable for percutaneous positioning.

**[0130]** Figures 19a depicts a crimping method for the support stent of the valve prosthesis device whereby stent 340 is crimped, that is, compressed or curled. In Figure 19b a crimping device 343 is shown, comprising a body having an annular void in which an expanded stent is positioned. Lever 346 is connected to the end 347 of the stent and as the lever is pulled the stent is curled or compressed about axle 345 into a compressed position 349 (Figure 19c).

**[0131]** Figures 20a and 20b depict a valve made of a simple tube mounted to a stent 352. During systole period the tube is fully open and during diastole period the tube collapses according to the mounting geometry 357 and achieves sealing.

**[0132]** Figure 21 describes a support stent 360 in its open position. Three of the longitudinal struts 362 are full and thick and always stay with their original constant size, serving as anchoring support. Each of these struts 362 is provided with a plurality of bores 364, which are later used for mounting the valve assembly (not shown) and tying it to stent 360. Between struts 362 a web-like construction is provided, which is capable of being crimped to a narrow state and capable of being deployed again to a wider state.

**[0133]** Figure 22 illustrates another implantable prosthetic valve. It comprises a metal tube 370, having three portions with a thicker wall 371 than in the rest of the tube 370, these areas form the longitudinal columns 372 in the construction, after the tube is cut to its final form. The advantage of such a construction is in its superior bending strength, in specific required portions of the construction, with minimal interference to the crimped volume of the whole construction.

**[0134]** Figure 23a to 23c depict a method of manufacturing an artificial or biological crimpable valve device. A piece of fabric material 370 (Fig. 23a), is dipped in PU to create a portion which is later formed into valve leaflets 371 (Fig. 23b). This composite material 371 is then attached to an additional piece of fabric such as PET 372 by means of stitching, suturing or other attaching technique 373 (Fig. 23c). The resulting fabric 375 is cut along stitching line 373 leaving enough material to later suture the valve assembly to the support construction. It is then formed to a tubular shape and stitched 374 (Fig. 23d). The tubular valve is then attached to a support construction 380 by suturing the bottom part around the valve 379 tightly to prevent leakage, and around the cut fabric line 376 (Fig. 23e). This open wall structure 378 allows blood flow to the coronary arteries. The valve is later placed with the coronary artery between the support columns 385. Additional variations of this can be made by replacing the composite material 371/370 with a biological patch such as a suitable pericardium patch. In some cases it is possible to make the same valve without cutting the fabric 372 with the shaped cut 376, and by that create a valve with an outer tubular shape. The embodiment of Figs. 23a to 23c is easy to manufacture as it is generally flat throughout most of the production process and only at the final stage of mounting on the support stent is it given a three-dimensional form.

**[0135]** Reference is now made to Figure 24a illustrating a frame of an implantable prosthetic valve having means for mounting valve leaflets that can form a tricuspid valve. Figure 24a depicts an isometric view of the frame and Figure 24b depicts a cross sectional view of the means for mounting valve leaflets 430 in detail. A frame 420, which is suitable for crimping and expanding, has three support beams 422 for mounting leaflets positioned substantially symmetrically about the circumference of the frame. Frame 420 is shown in Figure 24a in its deployed state. Support beam 422 has a "U" shaped lateral cross section, or profile (shown clearly in Figure 24b) that is designed to attach to a commissure of the valve structure. The "U" shape can be produced by extrusion, wire cutting or by welding the "U" profile to the frame's struts 421 at junction points 424. Support beam 422 is provided with a series of bores 425 positioned along its back wall. Bores 425 are designated for stitching the valve assembly by threads, wires, or other attaching means.

**[0136]** Figure 24b is a detailed cross-sectional view of one of the support beam 422. Two pericardial leaflets



430 are inserted through a U-shaped, or forked holder 428 that compresses and restricts the leaflets in the U-shaped profile. Leaflets 430 are folded to both sides of the support beam 422. When holder 428 is compressed toward the support beam 422, leaflets 430 are caught in-between holder 428 and support beam 422 so that the leaflets are kept in place. Figure 24c is an exploded view of the holder, bar 426 has a series of bores compatible for attachment to the frames support beam 422, attachment being achieved by suture 423 or any other attachment means. This attachment method allows attaching the leaflets to the frame without puncturing it with sutures and needles. It is also important that the leaflets are firmly held in place by the holder 428 so that it has no relative movement in respect to the rigid frame; hence avoiding wear due to movements. Leaflets that are made from pericardium are known to better withstand inner movements and stresses and less to wear by movement against rigid, hard or sharp bodies.

**[0137]** It is noted again that the entire valve structure is adapted to be radially crimped and radially expanded. This feature imparts the valve with the ability and ease to navigate through narrow passages in the vasculature during positioning of the device. After final positioning of the valve, the valve is deployed. This is made possible by the provision of a collapsible support frame structure. However, the length of the attaching means (the height of the valve) remains at all times constant; thus suitable for serving as the pliable valve assembly's anchorage. The leaflets are attached to the support frame at the attaching means, and due to their constant length there is no need for slack material as these attachment points that remain at constant distances regardless of the position of the valve assembly (crimped or deployed). This is an important feature for this means that the manufacturer of the valve device can make sure the valve assembly is secured and fastened to the support frame at all times. In prior art implantable valve devices, the entire support structure changes its dimensions from its initial first crimped position to final deployed position and this means that in the attachment of the valve leaflets to the support structure one must take into consideration these dimension changes and leave slack material so that upon deployment of the device, the valve assembly does not tear or deform. In the valve device there is no relative movement between the valve leaflets and the support beams (along the longitudinal central axis of the device). As a result, the valve device acquires greater durability and is capable of withstanding the harsh conditions prevailing within the vasculature and especially the millions of cycles of stress applied by the blood pressure.

**[0138]** The fixed attachment of the valve leaflets to the support frame in the valve assembly device renders it greater stability, enhanced safety, better sealing and consequently longer lifespan. The design of the valve device renders it longitudinal strength and rigidity whereas its collapsible support structure renders it radial flexibility.

**[0139]** Figures 25a to 25d illustrate another implanta-

ble prosthetic valve. Figures 25a and 25b depict an isometric view and an upper view of the valve assembly, respectively and Figures 25c and 25d illustrate upper views of two optional constructions for the means for mounting leaflets. Pericardial leaflets 430 are mounted on a deployable support frame 432. The frame is preferably made of three segments that form a circular support frame when assembled (Figure 25b). Pericardial leaflets 430 are attached to deployable support frame 432 along three substantially equidistant and substantially parallel beams 440, which are integral parts of support frame 432. Leaflets 430 are attached to support frame 32 at support beams 440 by suturing 446 leaflets 446 to support beams 440 through bores 442 in beams. The frame segments that are preferably made from stainless steel are pre-shaped 432 and can be formed in different ways. Figure 25c illustrates support frame segments 432a having beams 435a pointing inwardly. Figure 25d illustrates support frame segments 432b having beams 435b that are outwardly pointing. The advantages of this technique are the possibility to manufacture the frame segments from sheets (as opposed to tube) and the ease of assembly of the frame segments with the pericardial leaflets.

**[0140]** Figures 26a to 26c illustrate a tricuspid valve provided with a self-expandable frame. Figure 26a is an isometric view of an implantable prosthetic valve 430 mounted on a self-expandable frame 445. Implantable prosthetic valve 430 comprised of three valve leaflets is mounted on self-expandable frame 445 so that each leaflet extends along an equidistant portion of the frame and is sutured at both opposite sides to substantially equidistant and substantially parallel beams 440. By using a tapered tube 448 the whole assembly is crimped into a restriction tube 449. Figure 26b shows the crimped valve assembly 447 in its final crimped diameter ready for insertion to the body. After insertion into the desired location in the body the valve is released from the restriction tube and as it is made of self expandable material (like a shape-memory alloy), it expands back to the original diameter and is anchored in place. In order to reduce the diameter of the device from its fully expanded diameter to its crimped diameter a special tapered tube is used, shown in Figure 26c.

**[0141]** Figure 27 illustrates an isometric view of an implantable prosthetic valve having hooks designated to anchor the valve assembly to body ducts. An implantable prosthetic valve 450 is placed in a natural aortic valve position 452. Implantable prosthetic valve 450 comprises preferably three leaflets 430 mounted on a metallic support frame 455. The lower part of support frame 455 is provided with attachment means, preferably with hooks 453. Hooks 453 assures that the valve assembly stays in place after deployment, and cannot migrate to another position.

**[0142]** Figure 28 illustrates a partial view of an implantable prosthetic valve. The commissural attachment is shown in details. This figure demonstrates an attachment

technique that is used in order to attach pericardium leaflet 430 to a metallic frame 420. A longitudinal bar 456 having a narrow slit 457 is used as the commissural attachment so that extensions 463 of pericardium leaflet 430 are tightly inserted through slit 457. Pericardium extensions 463 that are extended beyond slit 457 are wrapped about a rigid bar 458 that acts as an anchoring means. Every two extensions originating from two sides of slit 457 are sutured to each other by a suture 459 at the side of rigid bar 458 opposite the slit. An additional suture 462 attaches the bottom circumference of support frame 420 to leaflet 420 in order to obtain sealing. The advantages of the described attachment are that no sutures or suture holes are applied in the leaflet working area, there are no concentrated stress points similar to stress point caused by suturing, and the force distribution is along the longitudinal bar 456. The narrow passage that is maintained through slit 457 forces the leaflets to be static in respect to the support so as to reduce abrasion.

**[0143]** The designs that will be shown herein after are optional configurations of attachment between the leaflets and the support frame.

**[0144]** Figures 29a and 29b illustrate an isometric view and an upper cross sectional view, respectively, of an attachment assembly of a valve's frame to leaflets. The attachment is similar in principle to the attachment shown in Figure 28, however, longitudinal bar 456 is further provided with an additional pole 465 that is attached to longitudinal bar 456 so as to establish an integral part. Pole 465 is rounded so as to make sure the leaflets will not be abraded or cut by sharp corners. In the cross sectional view shown in Figure 29b, adjacent leaflets 460 can be seen compressed together and the main protection goal is clearly shown.

**[0145]** Figures 30a to 30c illustrate an isometric view, a cross-sectional view and a flatten view, respectively, of an attachment assembly of a valves frame to leaflets. Using the method demonstrated in Figures 30a to 30c, the pericardial leaflets are pre-cut to the desired shape 430 and are provided with longitudinal bars 470 that are sutured to the leaflets creating a longitudinal clamping effect (Figure 30c). This allows distribution of forces along the whole length of the attachment means as opposed to concentrating the stresses in suture holes. In Figures 30a and 30b, an additional rigid portion 458 is added, creating a round ending, which prevents the leaflets from being bent drastically at the attachment point to portions of the frame 420. The attachment to frame 420 is performed using sutures 459.

**[0146]** Figures 31a and 31b illustrate an exploded view and an isometric view, respectively, of a commissural attachment depicting the attachment technique. A method of assembling pericardial leaflets 430 to a frame 420 is demonstrated. A rigid bar 476 provided with integral protrusions 478 is inserted through bores 479 that are pre-cut in pericardial leaflets 430. Integral protrusions 478 pass through a sheet of preferably PET (braided pol-

yster) fabric 475, and finally through bores 442 that are provided in longitudinal bar 440 (the attachment means) of frame 420. After the assembling of the parts, as shown in Figure 31b, the parts are tightly assembled and bar protrusions 478 are attached to bar 440 by welding, riveting or any other technique. The PET sheet 475 is folded and sutured tightly around bar 476 using suture 472.

**[0147]** Figures 32a to 32c illustrate an isometric view of an attachment between leaflets and the frame. An optional method of attachment is demonstrated, in which a pericardium leaflet 430 and bars 480 are sutured in area far as possible from the working area of the leaflets. The pericardium is first sutured using a suture 484 to bar 480 as seen in Figure 32b, and then folded and compressed. In order to firmly hold the pericardial leaflets in place between bars 480, an integral connecting member 482 connects the two bars, allowing the bent portions of the bars to be in parallel position, with the leaflets caught in between. Then, an additional suture 483 connects the bottom side of the bar to the leaflets so that while the valve is working, the leaflets do not bear high stresses.

**[0148]** Figures 33a to 33d illustrate different views of portions of an attachment between a pericardium and a frame, demonstrating another method of attachment. A connecting member 490 (shown in a deployed position in Figure 33d) is used to connect two pericardial leaflets 492 at the line of the commissure. After being connected between them, pericardial leaflets 492 are being connected to frame bar 480. Here again, the principal of compressing the leaflets between two bent portions bars 491 of connecting member 490 and tightening them using suture 484 without punctures in the working areas of the pericardium is applied. However, connecting member 490 is provided with a portion 493 that is positioned perpendicular to the two bent portions bars 491 that holds the two leaflets together. Portion 493 is the connecting member to frame's bar 480. In Figure 33a, the junction point 495 between the portions of connecting member 491 is placed at the upper part (outlet) of the frame so as to achieve a rigid connection to the frame. In Figure 33b, junction point 495 is placed at the bottom part (inlet) of the frame so that the junction point also functions as a spring. Comprehensive explanation of the benefits of springs in commissures is discussed and shown in respect with Figures 37 to 39.

**[0149]** Figures 34a to 34c illustrate an isometric view of an attachment between a pericardium and a valve demonstrating another method of attachment. In Figures 34b and 34c, a deployed portion and the folded portion, respectively, are shown. An optional design for the attachment between the frame and the leaflets is depicted. A connecting member 480 (shown clearly in Figure 34b) is being produced into a flat configuration using laser-cutting. Connecting member 480, which is a part of the frame's attachment means, is bent and then is ready for assembly with the leaflets. Connecting member 480 comprises the main body as well as a connection bar 497 and a flexible element 498 allowing flexibility to the com-

missural. Leaflets 430 are threaded through corresponding holes 481 in the structured connecting member 480 and are sutured using a suture 482.

**[0150]** Reference is now made to Figures 35a, 35b, and 35c illustrating isometric and cross-sectional upper views, respectively, of attachment techniques between a pericardium leaflet and a valve's frame. Figures 35b and 35c depict different techniques of commissural attachments: in Figure 35b two pieces of pericardial leaflets 500 are wrapped around a metallic member 505 that is connected to a frame 501. Rigid members 503 are positioned from both sides of metallic member 505 and then tightened together and connected by a suture 502. All metallic pieces are wrapped by PET fabric 508 in order to avoid direct contact between the metallic pieces and the delicate pericardial leaflets. The advantage of this structure is that after tightening the suture, the whole commissure becomes static with no relative movement between the portions. This improves the valve assembly's resistance to abrasion. In addition, there are no needle holes or sutures in the working area. Figure 35c depicts a similar structure, however, there is no use of rigid sidebars. After wrapping the metallic member 505 with pericardial leaflets 500, a piece of PET 508 is used for tightening it to a tight bundle. In this case, the suture line 502 is the borderline of the working area so it should be designed so that stresses are in the best possible distribution.

**[0151]** Figures 36a and 36b focus on the connection of the commissural assembly to frame's protrusion 509, which is an integral part of the frame and is the basis for the commissural attachment. This example shows the use of four rigid longitudinal bars 503 connected by a suture 502.

**[0152]** Figures 37a to 37c illustrate a commissural assembly, where the connecting bar functions as a flexible support and has integral attachment means to the frame. Figure 37b is an isometric view of the connecting bar. Connecting bar 520 is flexible and comprises a resilient material shaped in a "U" shape. Connecting bar 520 is a part of commissural assembly 527 shown in Figure 37a. Connecting bar 520 is provided with protruding elements 521 that are acting as the means of attachment to the frame's bar 480. Protruding elements are designated to be inserted in corresponding bores 442 in bar 480. It is optional to provide rods 527 which are integral parts of the "U" shaped member and replace the suture 526 that connects the pericardium leaflet and the connecting bar together, which is shown in Figure 37a. Figure 37c depict another method of attaching the flexible connecting bar 520 to the frame 480 by means of welding 523. Here the pericardial leaflets 500 are attached to the connecting bar 520 by suture 526 inserted through a PET fabric 508 and two connecting bars 503, which together create a tight bundle.

**[0153]** Figures 38a to 38g illustrate isometric views of flexible commissural supports and the method of attaching them to a pericardium and a frame a valve. Figures

38a to 38c demonstrate incorporation of different design options of commissural springs. The main purpose of a commissural spring is to reduce the impact applied to the pericardial leaflets when the valves leaflets are closed.

5 If the structure is of a rigid nature, high stress will be applied each time the valve closes. If a spring is added to the structure, the spring will bear the highest portion of the impact; thus reducing the stress applied to the leaflets during the time the valve is closed. In Figure 38a, a simple stainless steel spring 530 is connected to frame's bar 480 by threading a portion of the spring into slots 538 as shown in more detail in Figures 38e and 38f. In Figure 38b, there is a similar spring 530 with leaflets 500 connected to it by one of the attachment methods, the commissural support itself 530 is connected to the frames bar 480 by spot welding, laser welding or other attachment means. Figure 38c depicts a similar spring 534 having an additional spiral. The purpose of such a spiral is to reduce stress in the spring and to allow the fatigue requirements, which in the case of heart valves are of at least 200 million cycles.

**[0154]** Figure 38d illustrates an isometric view of a flexible commissural support demonstrating the attachment of the pericardium to the support. Figures 38e to 38g are the details of the attachment to the frame. A commissural spring of a different design 539 comprises a stainless steel wire of a small diameter in respect with the springs described in Figures 38a to 38c. One advantage of this structure is the distribution of stresses in the spring and the ability to form a structure, which can be crimped to a small diameter. Another advantage in this structure is that there are no open edges of the spring, which can be dangerous when operated; the open edges are protected in the frame's bar as shown in Figures 38e to 38g, which show possible attachment methods of the spring to the frame. In Figure 38e, a frame's flat bar 480 cut in shape with slots for crimping the spring 536. Figure 38f shows pre-bending of the slots 527 and Figure 38g shows the spring legs 539 assembled firmly into the slots 538.

**[0155]** Figure 39a illustrates a technique of commissural assembly using a shaped compressing member 511. The compression member 511 holds pericardial leaflets 500 firmly while pressing it in the pivot points 513. A radial edge 514 is made in order to protect the pericardium from abrasion. The whole assembly is held tightly inside the compressing member 516. The commissural assembly is connected to the frame by protrusion member 518, which fit bores in the frames bar 480. Figure 39b is an isometric view of the same detail.

**[0156]** Figures 40a to 40c illustrate an isometric view of a bicuspid valve mounted on a frame. Figures 40b and 40c depict a cross-sectional side view and an isometric view, respectively, of the pericardium that is sutured to a PET tube in the form of pockets. The valve assembly (in this case bicuspid) comprises a crimpable frame 540, two pericardial leaflets 545, a PET skirt 543 and a connecting suture 547. The focus in this drawing is on the pocket shape of the pericardium leaflet shown best in

Figures 40b and 40c. One of the main goals in valve design, in general, is to distribute the stresses in a homogenous way in the pericardium material and the attachment areas. The design of the pericardium leaflet as a pocket assists in distributing the stresses along suture line 547; pericardium leaflet 545 is sutured to PET skirt 543 along connecting suture 547. PET skirt 543 is sutured to the circumference of crimpable frame 540 at the bottom side 549 and at the top 542 using one of the commissural attachments that are described herein before. When hydrodynamic pressure is applied on leaflets 545, the leaflets will meet in the center 546 of frame 540 so as to seal the valve assembly. The shape of the leaflets in the valve assembly is determined by the boundary conditions, which in this case are the suture lines. The suture lines can be designed to have an optimal shape regarding the stress distribution in accordance with geometrical restrictions.

**[0157]** Reference is now made to Figures 41a to 41d illustrating isometric views of an implantable prosthesis tricuspid valve. Figure 41a illustrates valve assembly 553 in an open state. Valve assembly 553 comprises a frame 555 (rigid or crimpable), pericardial leaflets 550 and bars 551. It is emphasized that the goal is to distribute the stresses on the commissural arrangement in an optimal way. Pericardial leaflets 550 are attached to bars 551 that act as attachment means. The attachment means are positioned at the top third of the valve; the bottom circumference is attached to the frame in order to obtain full sealing. The middle part of the pericardium is left slack. The pre-cut pericardium is cut in greater dimensions than the frame; e.g., the height of the pericardium leaflet is greater than the height of the frame, for example, if the frame height is 15 mm, the pericardium will be cut to a height of 18 mm so as to establish a slack portion in the middle area of the valve assembly 553. Figure 41b depicts the valve assembly in a closed state. The slack portion of the pericardium collapses toward the middle while creating a small pocket shape 554, which assists in the stress distribution. Figure 41c shows the detailed commissural and the short bar attachment as well as the circumference sealing area at the bottom portion of the pericardium assembly. It is shown in the figures that bars 551, which are relatively short, allow firm attachment of the top portion of the commissural, slack portion in the middle, and a good sealing surface at the bottom portion 556.

**[0158]** Reference is now made to Figures 42a and 42b illustrating an isometric view of an implantable prosthetic valve having a different commissural attachment. Figure 42b depicts the attachment in details. In Figure 42a, similar valve assembly is illustrated, while the short bar is arranged in a manner that is similar to the structure shown in Figure 28 and described herein before. Relatively short bars 559 act as the attachment means to the frame bar 558. Suture 557 attaches short bars 559 to a member 558, the suture can be made from an elastic material so that to add flexibility to the commissures and to render

the valve assembly the benefits already explained herein.

**[0159]** Reference is now made to Figures 43a and 43b illustrating an isometric view of an implantable prosthetic valve. Figure 43a depicts commissures that are pre-sutured in a tapered shape. The valve assembly shown in Figure 43a comprises a frame 560, pericardial leaflets 563, and attachment means 561. Pericardial leaflets 563 are shown to be in an open state so as to establish an open valve assembly while dashed lines 565 show the valve in a closed sealed state. The attachment to the commissures can be performed using one of the explained techniques. Specifically to Figures 43a and 43b, the focus is on the formation of a tapered valve in which the attachment means is in the shape of long bars 561 that are attached to the pericardium in an angular way in apposition to the parallel attachment. Attaching the bars in an angular way when the pericardium is flattened will create a tapered tube when built up to the three dimensional shape. When the whole prosthetic valve is inflated by a balloon, the pericardium leaflet, at the top circumference of the frame, is stretched and the frame is expanded to the full diameter. After deflating the balloon, the frame stays in its expended size but the pericardial leaflets regains their pre-stretched shape. This process creates a permanent clearance distance 562 between the pericardial leaflets 563 and frame 560. This is of major importance in the protection of the pericardium from abrading against the frame.

**[0160]** Reference is now made to Figures 44a to 44c illustrating an isometric view of an implantable prosthetic valve, with additional pieces of PET used for sealing and protecting the pericardium. The illustrated implantable valve assembly resembles the valve shown in Figure 43, however, it is emphasized that in the attachment of the pericardial leaflets 570 to frame 575, there is use of PET. Figure 44c shows in a cross-sectional view, the way the PET is assembled to the pericardium and the frame in a manner that protects the pericardium against wear. PET 571 and 572 are used for connecting pericardial leaflets 570 to frame 575, while they are assembled in between the leaflets and the frame. A sutured 577 connects pericardium leaflet 570 in between two layers of PET, while the inner layer of PET 572 is short and the outer layer is longer. Bottom attachment suture 576, connects the three layers, the leaflet and both PET layers to the frame and forms a strong sealing line. An upper suture 578 connects the outer PET layer 571 to frame 575. When the valve assembly closes and the pericardial leaflets come closer to each other at the top of the assembly, there is a tendency of the bottom attachment to move and rotate about an attachment point 577. Upper suture line 578 keeps the outer PET layer tight and prevents a part of this rotational movement, which can rapidly cause an abrasion failure.

**[0161]** Figures 45a to 45d illustrate an isometric view of an implantable prosthetic valve having leaflets sutured to a pre-shaped PET tube and optional leaflet-tube attachments in details. A technique of mounting pericardial

leaflets 580 to a pre shaped PET tube 585 is shown. The tube is shaped so as to have a folding 586 with substantially sinusoid pattern 586 that is similar to the optimal connection line of valve leaflets in the natural valve. This shape allows the pericardial leaflets to be sutured to the interior of the PET tube. The preferred suturing techniques are shown in the cross sectional views of PET tubes in Figures 45b, 45c, and 45d. Generally, in order to protect the pericardial leaflets from tearing, an additional piece 583 of PET is added below the suture lines. Similar variations are shown in Figures 45c and 45d.

**[0162]** Reference is now made to Figure 46a illustrating an exploded view of an implantable prosthetic valve assembly, the where the leaflets are mounted on a pre-cut and pre-shaped tube and the outlet of the valve is cut in a commissural shape. Figure 46a is view of the attachment. A pre-shaped PET tube 590 is cut to have substantially sinusoidal shape 596 and then bent in order to provide a suturing area. The pericardium leaflet 593 is pre-cut and assembled to PET tube 590 by means of suturing 502. In this case as well as in the former case, an additional protective layer of PET or pericardium 594 is added. Figure 46b is a cross-section of the attachment detail after being tightened

**[0163]** Figures 47a to 47c illustrate a partial cross-sectional side view of an inflating balloon. The balloon is a part of an implantable prosthetic valve delivery system Figures 47b and 47c are cross sectional upper views in the inflated and deflated positions, respectively. The specially designed balloon shown in the figures preferably comprises four inflating members, three substantially identical and symmetrical sections 600 and a central section 602. Pericardial leaflets 612 are positioned between sections 600 and separate them. A frame 610 circles the inflating members and a balloon shaft 619 that is positioned in the center of the delivery system while a commissural connection 613 connects pericardial leaflets 612 to frame 610. The inflated balloon sections 600 are placed between frame 610 and pericardial leaflets 612 so that when the inflating members are inflated, they push leaflets 612 toward each other and frame 610 so as to establish a fully closed position. This technique better preserves the leaflets since there is no contact between the leaflets and the frame besides in the commissural connection. The preservation of the leaflets is even improved in times of inflation as well as after inflating the valve and establishing a closed position. In Figure 47a the fourth inflating member of the balloon, central section 602 is clearly shown. Through central section 602, the inlet 617 of the valve is inflated while the inflated central section assures that the whole valve is fully inflated to substantially round shape. Figure 47c shows the assembly in a crimped position. Frame 610 is crimped and sections 600 are deflated. Pericardial leaflets 612 are also shown in a crimped configuration.

**[0164]** Figures 48a and 48b illustrate a partial cross-sectional side view and an upper cross sectional view of an inflating balloon. The inflating balloon comprises of a

central inflating balloon 620 and three protection sheets 622. In the lateral cross-section shown in Figure 48b, the parts of inflated assembly 625 are clearly shown, protection sheets 622 protects the pericardial leaflets 624 from being pushed against the frame 625 when the device is inflated. The advantage of this arrangement is in the protection of the pericardial leaflets.

**[0165]** The implantable prosthetic valve is relatively easy to manufacture as it is generally flat throughout most of the production process and only at the final stage of mounting the other elements of the valve assembly on the support frame, a three dimensional form is established.

**[0166]** A typical size of an aortic prosthetic valve is from about 19 to about 25 mm in diameter. A maximal size of a catheter inserted into the femoral artery should be no more than 8 mm in diameter. The present invention introduces a device, which has the ability to change its diameter from about 4 mm to about 25 mm. Artificial valves are not new; however, artificial valves in accordance with the present invention possess the ability to change shape and size for the purpose of delivery and as such are novel. These newly designed valves require manufacturing methods and technical inventions and improvements, some of which were described herein.

**[0167]** As mentioned earlier, the material of which the valve is made from can be either biological or artificial. In any case new technologies are needed to create such a valve.

**[0168]** To attach the valve to the body, the blood vessels determine the size during delivery, and the requirements for it to work efficiently, there is a need to mount it on a collapsible construction which can be crimped to a small size, be expanded to a larger size, and be strong enough to act as a support for the valve function. This construction, which is in somewhat similar to a large "stent", can be made of different materials such as Nitinol, biocompatible stainless steel, polymeric material or a combination of all. Special requirements for the stent are a subject of some of the embodiments discussed herein.

**[0169]** In the traditional procedure the valve is sutured in place by a complicated suturing procedure. In the case of the percutaneous procedure there is no direct access to the implantation site therefore different attachment techniques are needed.

**[0170]** Artificial polymer valves require special treatment and special conditions when kept on a shelf, as well as a special sterilization procedure. One of the consequences of the shelf treatment is the need to crimp the valve during the implantation procedure. A series of devices and inventions to allow the crimping procedure are disclosed herein.

**[0171]** It should be clear that the description of the embodiments and attached Figures set forth in this specification serves only for a better understanding of the invention, without limiting its scope as covered by the following claims.

**[0172]** It should also be clear that a person skilled in

the art, after reading the present specification could make adjustments or amendments to the attached Figures and above described embodiments that would still be covered by the following claims.

### Claims

1. A percutaneously implantable prosthetic device for replacing a deficient native aortic valve, comprising:

- a collapsible and expandable support stent formed of a shape memory alloy, the support stent adapted to be initially crimped into a narrow configuration suitable for catheterization through a body duct to a target location,

-- the support stent comprising a proximal stent portion (310) configured to expand to a first diameter and

-- a distal stent portion (320) configured to expand to a second diameter, the first diameter being smaller than the second diameter for preventing deformation of the mitral valve by over expansion and for providing a difference between the support stent and aortic root so that the openings of the coronary arteries will not be blocked; and

- a collapsible and expandable valve assembly having leaflets formed of pericardial tissue,

whereby the valve assembly is attached to the support stent and has an open position suitable to allow blood to pass from an inlet to an outlet of the valve assembly and has a closed position suitable to provide blockage to a reverse flow;

wherein the first diameter of the support stent is sized for engagement with the leaflets of the native aortic valve and the second diameter of the support stent is sized for engagement with the inner wall of the ascending aorta and

wherein the stent is sized to avoid a contact with the inner wall of a left ventricle when implanted.

2. The prosthetic device of claim 1, wherein the valve assembly is provided in the proximal stent portion (310).

3. The prosthetic device of claim 1 or 2, wherein the shape memory alloy is nickel titanium.

4. The prosthetic device of any one of the preceding claims, wherein the support stent is collapsible to a delivery diameter sized for advancement through a femoral artery, wherein the delivery diameter is preferably less than 8 mm.

5. The prosthetic device of any one of the preceding claims, wherein the first diameter of the support stent is in the range of about 19 mm to 25 mm.

6. The prosthetic device of any one of the preceding claims, wherein the valve assembly is sewn to the support stent.

7. The prosthetic device of any one of the preceding claims, wherein the valve assembly is a tricuspid valve configuration.

8. The prosthetic device of any one of the preceding claims, wherein the support stent has an annular shape.

9. The prosthetic device of any one of the preceding claims, wherein the valve assembly is contained within the proximal stent portion (310).

10. The prosthetic device of any one of the preceding claims, wherein the second diameter of the distal stent portion (320) is sized for decreasing the risk of device migration.

11. The prosthetic device of any one of the preceding claims, wherein the support stent comprises stent struts which contact the leaflets of the native aortic valve and the inner wall of the ascending aorta.

12. The prosthetic device of claim 11, wherein a blood supply is preserved through the stent struts opposite the openings of the coronary arteries.

13. The prosthetic device of claim 12, wherein the distal stent portion is adapted to be over dilated in the ascending aorta.

14. The prosthetic device of any one of the preceding claims, wherein the support stent is formed with a net-like frame adapted to be crimped evenly to a narrow annular configuration suitable for catheterization, the support stent adapted for radial deployment at a target location

15. The prosthetic device of any one of the preceding claims, wherein the valve assembly is sewn to the support stent at several anchoring points.

### Patentansprüche

1. Perkutan implantierbare prothetische Vorrichtung zum Ersetzen einer fehlerhaften natürlichen Aortenklappe, die umfasst:

- einen zusammenlegbaren und ausdehnbaren Stützstent, der aus einer Formspeicherlegie-

rung ausgebildet ist, wobei der Stützstent geeignet ist, anfänglich in einen schmalen Aufbau gefaltet zu werden, der zur Katheterisierung durch einen Körpergang zu einem Zielort geeignet ist,

- wobei der Stützstent einen proximalen Stentabschnitt (310) umfasst, der aufgebaut ist, um sich auf einem ersten Durchmesser auszudehnen, und
- einen distalen Stentabschnitt (320), der aufgebaut ist, um sich auf einen zweiten Durchmesser auszudehnen, wobei der erste Durchmesser kleiner als der zweite Durchmesser ist, um die Verformung der Mitralklappe durch Überdehnung zu verhindern und um einen Unterschied zwischen dem Stützstent und der Aortenwurzel bereitzustellen, so dass die Öffnungen der Herzkranzgefäße nicht blockiert werden; und

- eine zusammenlegbare und ausdehnbare Klappenanordnung mit Blättchen, die aus Herzbeutelgewebe ausgebildet sind,

wobei die Klappenanordnung an dem Stützstent angebracht ist und eine offene Position hat, die geeignet ist, Blut von einem Einlass zu einem Auslass der Klappenanordnung passieren zu lassen, und eine geschlossene Position hat, die geeignet ist, um eine Blockierung für einen umgekehrten Fluss bereitzustellen;

wobei der erste Durchmesser des Stützstents für den Eingriff mit den Blättchen der natürlichen Aortenklappe dimensioniert ist, und der zweite Durchmesser des Stützstents für den Eingriff mit der Innenwand der aufsteigenden Aorta dimensioniert ist, und

wobei der Stent dimensioniert ist, um einen Kontakt mit der Innenwand einer linken Herzkammer zu vermeiden, wenn er implantiert ist.

2. Prothetische Vorrichtung nach Anspruch 1, wobei die Klappenanordnung in dem proximalen Stentabschnitt (310) bereitgestellt ist.
3. Prothetische Vorrichtung nach Anspruch 1 oder 2, wobei die Formspeicherlegierung Nickeltitan ist.
4. Prothetische Vorrichtung nach einem der vorhergehenden Ansprüche, wobei der Stützstent auf einen Führungsdurchmesser zusammenlegbar ist, der für das Vorrücken durch eine Oberschenkelarterie dimensioniert ist, wobei der Führungsdurchmesser vorzugsweise kleiner als 8 mm ist.
5. Prothetische Vorrichtung nach einem der vorherge-

henden Ansprüche, wobei der erste Durchmesser des Stützstents in dem Bereich von etwa 19 mm bis 25 mm ist.

- 5 6. Prothetische Vorrichtung nach einem der vorhergehenden Ansprüche, wobei die Klappenanordnung mit dem Stützstent vernäht ist.
- 10 7. Prothetische Vorrichtung nach einem der vorhergehenden Ansprüche, wobei die Klappenanordnung ein Trikuspidalklappenaufbau ist.
- 15 8. Prothetische Vorrichtung nach einem der vorhergehenden Ansprüche, wobei der Stützstent eine ringförmige Form hat.
- 20 9. Prothetische Vorrichtung nach einem der vorhergehenden Ansprüche, wobei die Klappenanordnung in dem proximalen Stentabschnitt (310) enthalten ist.
- 25 10. Prothetische Vorrichtung nach einem der vorhergehenden Ansprüche, wobei der zweite Durchmesser des distalen Stentabschnitts (320) dimensioniert ist, um die Gefahr der Vorrichtungsmigration bzw. Wanderung zu senken.
- 30 11. Prothetische Vorrichtung nach einem der vorhergehenden Ansprüche, wobei der Stützstent Streben umfasst, die die Blättchen der natürlichen Aortenklappe und die Innenwand der aufsteigenden Aorta berühren.
- 35 12. Prothetische Vorrichtung nach Anspruch 11, wobei die Blutzufuhr durch die Stentstreben gegenüber den Öffnungen der Herzkranzgefäße gewahrt wird.
- 40 13. Prothetische Vorrichtung nach Anspruch 12, wobei der distale Stentabschnitt geeignet ist, in der aufsteigenden Aorta überdehnt zu werden.
- 45 14. Prothetische Vorrichtung nach einem der vorhergehenden Ansprüche, wobei der Stützstent mit einem netzartigen Rahmen ausgebildet ist, der geeignet ist, gleichmäßig in einen schmalen ringförmigen Aufbau gefaltet zu werden, der zur Katheterisierung geeignet ist, wobei der Stützstent für die radiale Entfaltung an einem Zielort geeignet ist.
- 50 15. Prothetische Vorrichtung nach einem der vorhergehenden Ansprüche, wobei die Klappenanordnung an mehreren Verankerungspunkten mit dem Stützstent vernäht ist.

#### 55 Revendications

1. Un dispositif prothétique implantable de manière percutanée destiné à remplacer une valve aortique

native déficiente, comprenant :

- un stent de support affaissant et extensible formé d'un alliage à mémoire de forme, le stent de support adapté pour être initialement rétréci dans une configuration étroite adaptée en vue d'une cathétérisation à travers un conduit corporel vers un site cible,
    - le stent de support comprenant une portion de stent proximale (310) configurée pour se développer jusqu'à un premier diamètre et
    - une portion de stent distale (320) configurée pour se développer jusqu'à un second diamètre, le premier diamètre étant plus petit que le second diamètre afin d'empêcher la déformation de la valve mitrale par une surexpansion et d'assurer une différence entre le stent de support et la racine aortique de sorte que les ouvertures des artères coronaires ne soient pas bloquées ; et
  - un ensemble de valve repliable et expansible ayant des folioles formées de tissu péricardique, par lequel l'ensemble de valve est attaché au stent de support et a une position ouverte adaptée pour permettre au sang de passer d'une entrée vers une sortie de l'ensemble de valve et a une position fermée adaptée pour assurer le blocage d'un flux inverse ; dans lequel le premier diamètre du stent de support est dimensionné de manière à s'engager avec les folioles de la valve aortique native et le second diamètre du stent de support est dimensionné pour s'engager avec la paroi interne de l'aorte ascendante et dans lequel le stent est dimensionné de manière à éviter un contact avec la paroi interne d'un ventricule gauche lors de son implantation.
2. Le dispositif prothétique de la revendication 1, dans lequel l'ensemble de valve est disposé dans la portion de stent proximale (310).
  3. Le dispositif prothétique de la revendication 1 ou 2, dans lequel l'alliage à mémoire de forme est du nickel titane.
  4. Le dispositif prothétique de l'une quelconque des revendications précédentes, dans lequel le stent de support est repliable en un diamètre de pose dimensionné en vue de son avancement à travers une artère fémorale, dans lequel le diamètre de pose est de préférence de moins de 8 mm.
  5. Le dispositif prothétique de l'une quelconque des revendications précédentes, dans lequel le premier diamètre du stent de support est dans la gamme d'environ 19 mm à 25 mm.
  6. Le dispositif prothétique de l'une quelconque des revendications précédentes, dans lequel l'ensemble de valve est cousu au stent de support.
  7. Le dispositif prothétique de l'une quelconque des revendications précédentes, dans lequel l'ensemble de valve est une configuration de valve tricuspide.
  8. Le dispositif prothétique de l'une quelconque des revendications précédentes, dans lequel le stent de support a une forme annulaire.
  9. Le dispositif prothétique de l'une quelconque des revendications précédentes, dans lequel l'ensemble de valve est contenu dans la portion de stent proximale (310).
  10. Le dispositif prothétique de l'une quelconque des revendications précédentes, dans lequel le second diamètre de la portion de stent distale (320) est dimensionné de manière à réduire le risque de migration du dispositif.
  11. Le dispositif prothétique de l'une quelconque des revendications précédentes, dans lequel le stent de support comprend des montants qui sont en contact avec les folioles de la valve aortique native et la paroi interne de l'aorte ascendante.
  12. Le dispositif prothétique de la revendication 11, dans lequel un apport sanguin est préservé par le biais des montants de stent opposés aux ouvertures des artères coronaires.
  13. Le dispositif prothétique de la revendication 12, dans lequel la portion de stent distale est adaptée pour être surdilatée dans l'aorte ascendante.
  14. Le dispositif prothétique de l'une quelconque des revendications précédentes, dans lequel le stent de support est formé à l'aide d'une structure en treillis adaptée pour être rétrécie uniformément en une configuration annulaire étroite adaptée à la cathétérisation, le stent de support adapté pour un déploiement radial en un site cible.
  15. Le dispositif prothétique de l'une quelconque des revendications précédentes, dans lequel l'ensemble de valve est cousu au stent de support en plusieurs points d'ancrage.



FIG. 1

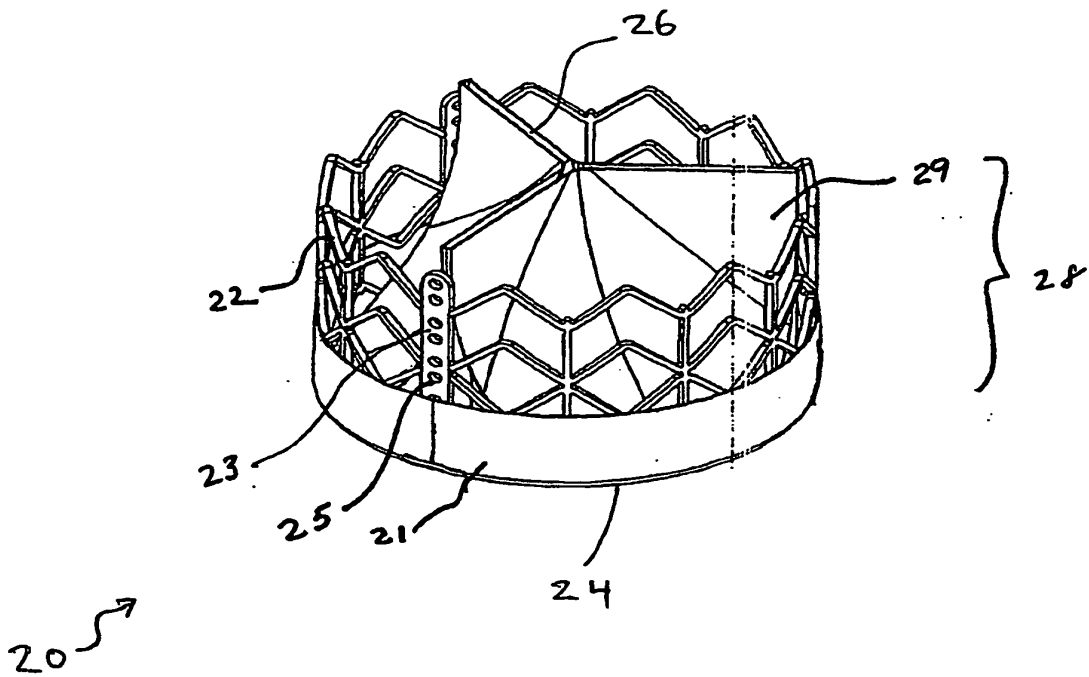
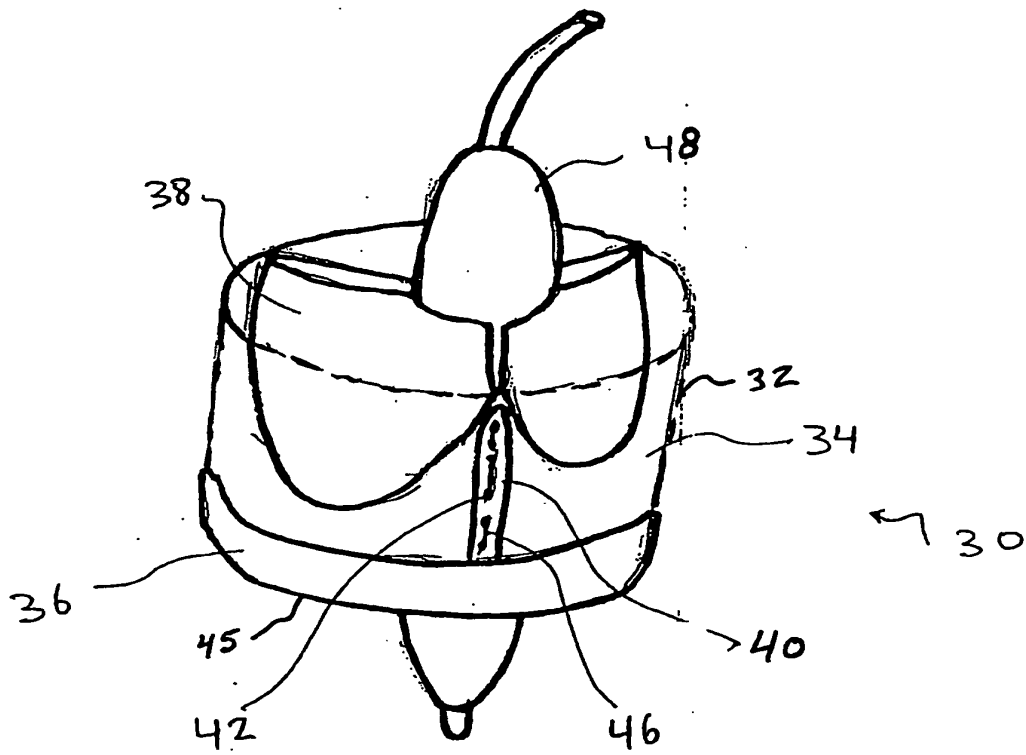


FIG. 2



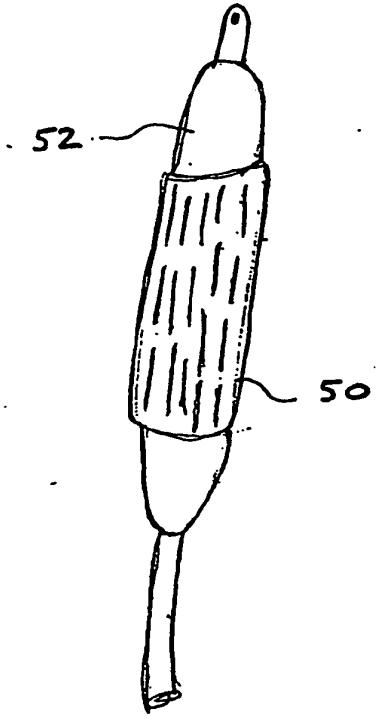


FIG. 3

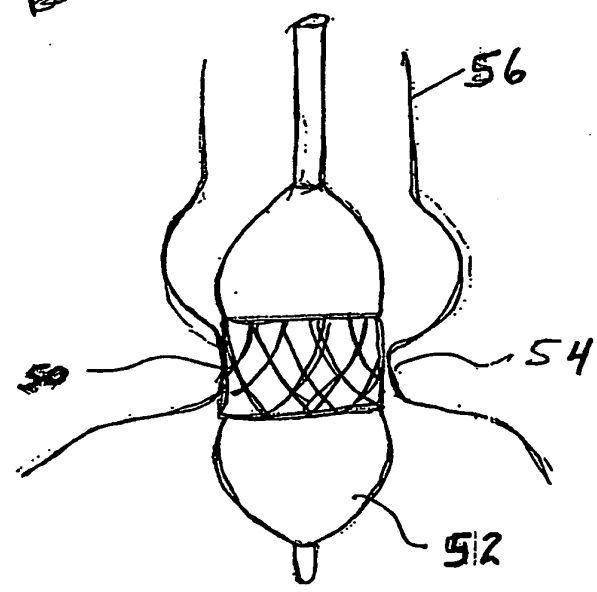
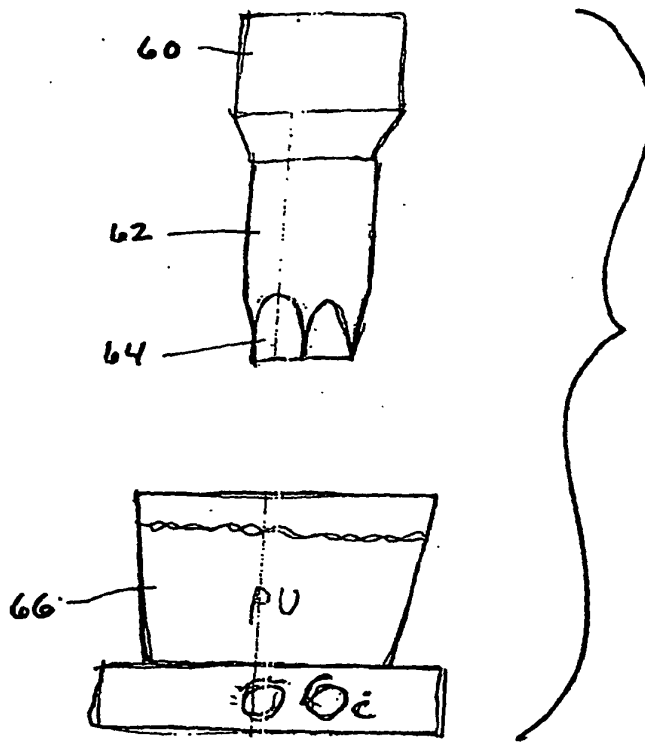


FIG. 4

FIG. 5



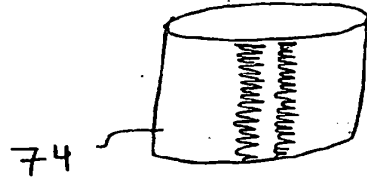


Fig. 6a

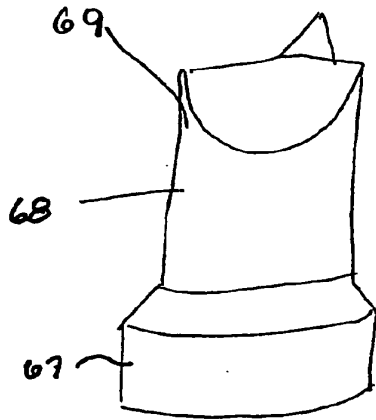


Fig. 6b

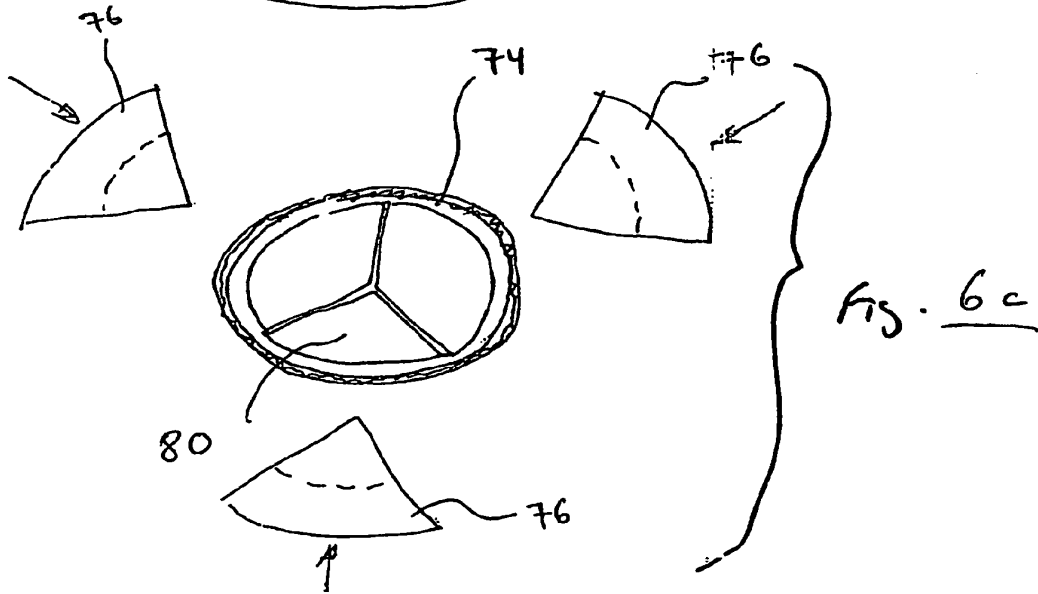
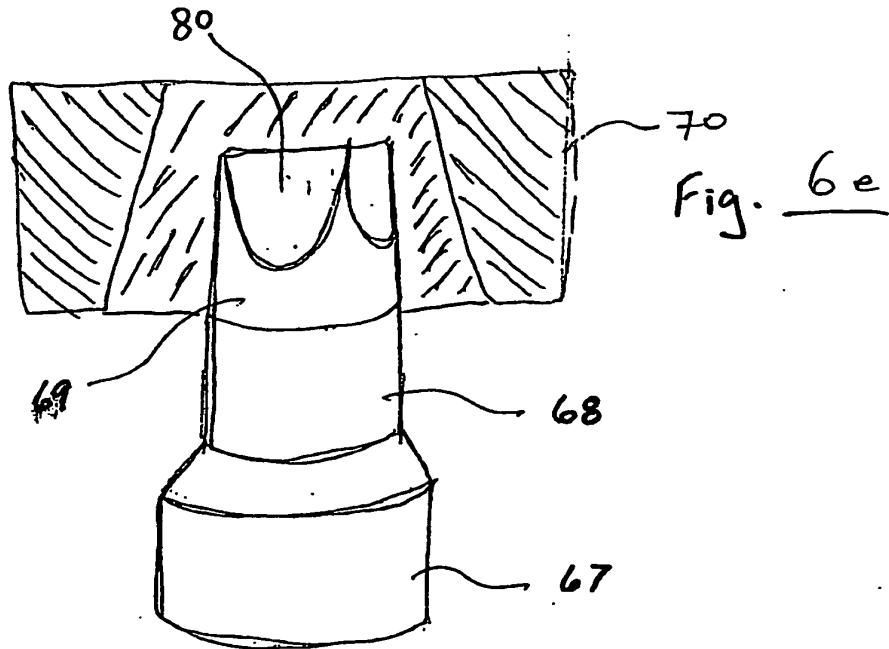
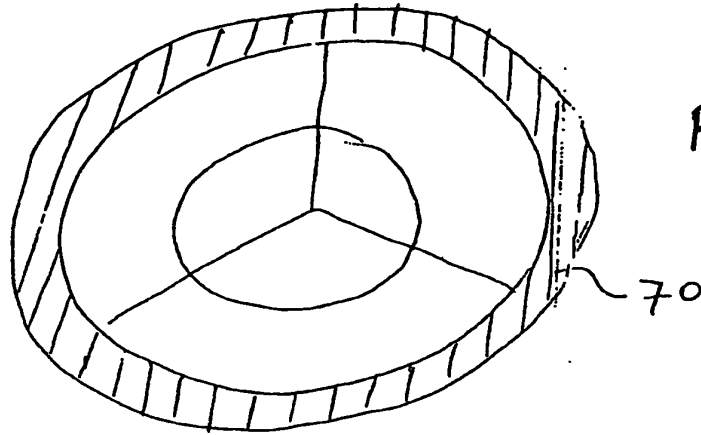


Fig. 6c



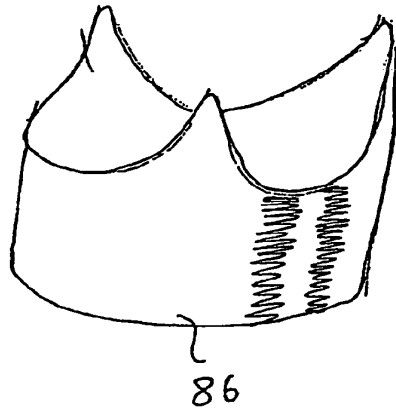


FIG. 7a

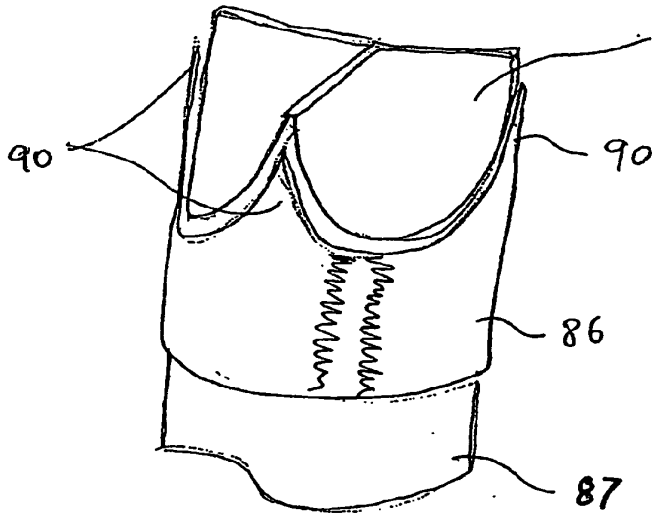


Fig. 7b

FIG 8a

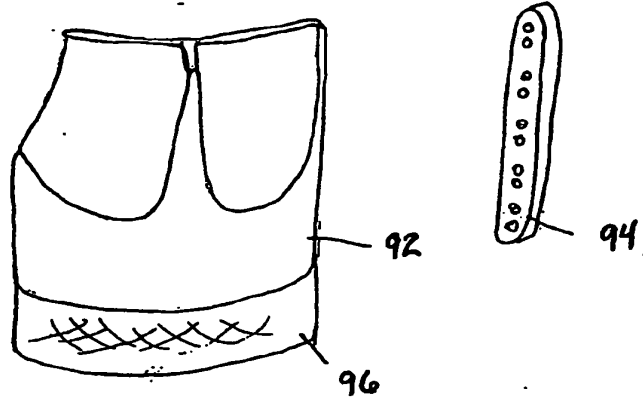


Fig. 8b

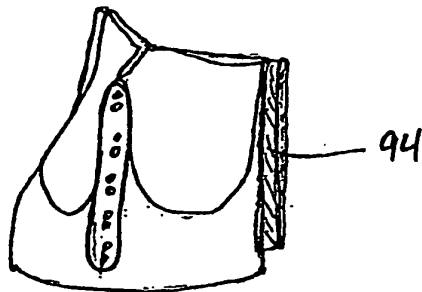




FIG. 9

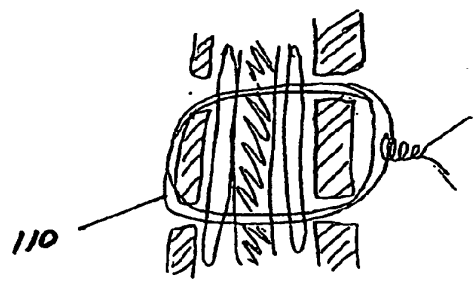
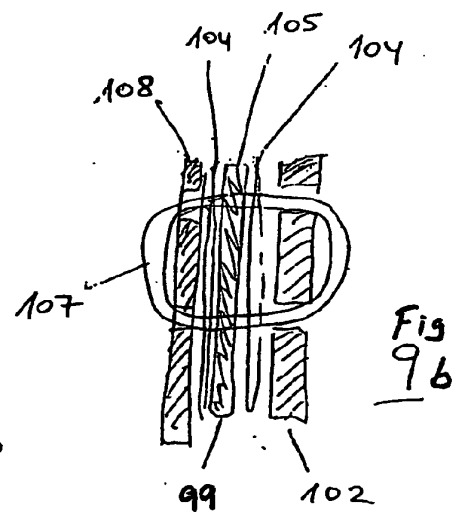
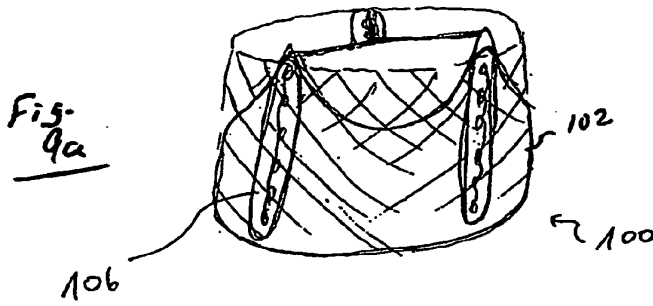
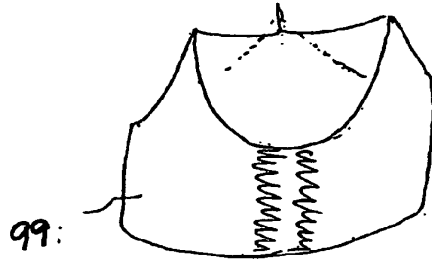


Fig. 9d

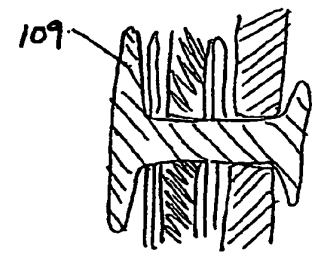
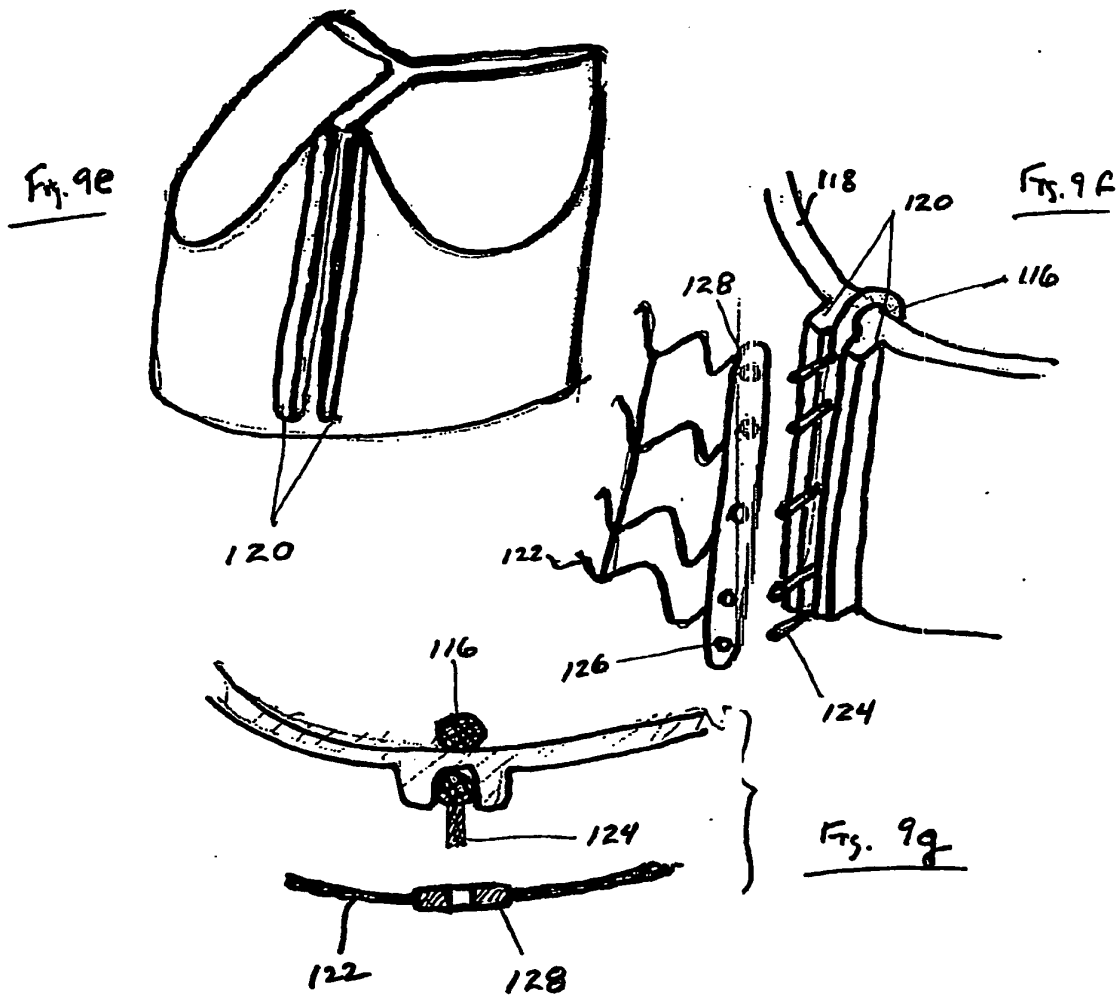


Fig. 9c



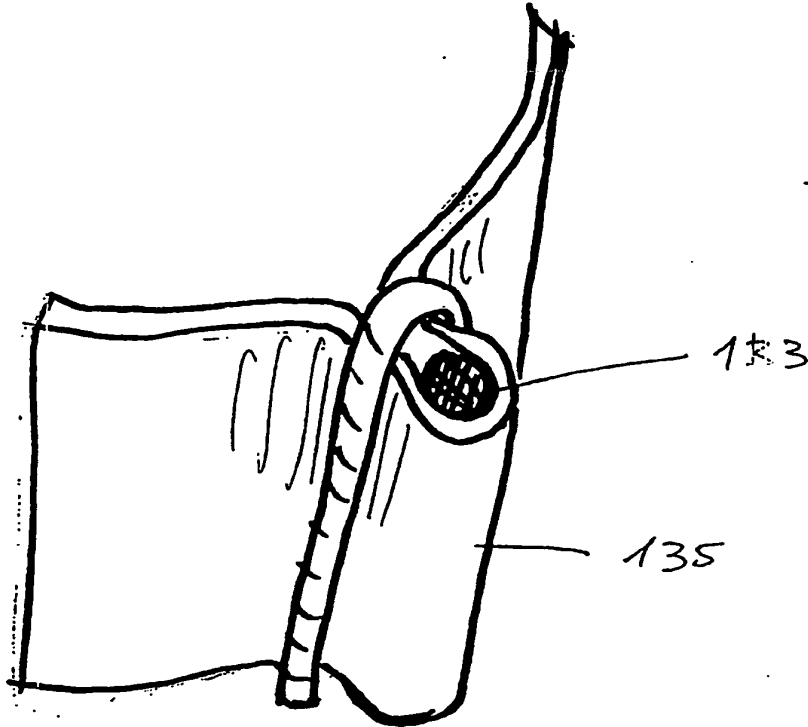


Fig. 9h

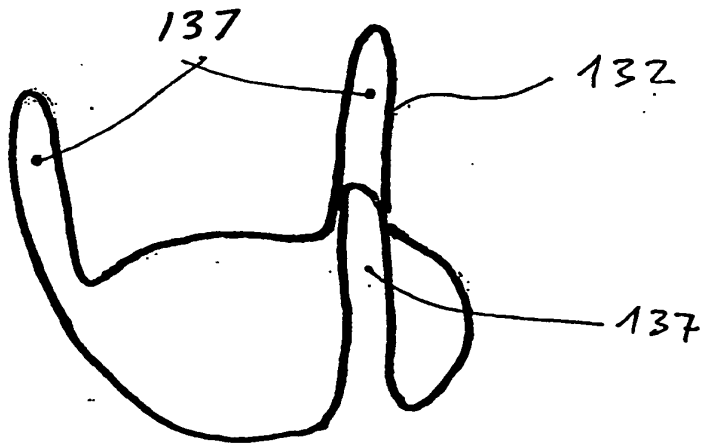
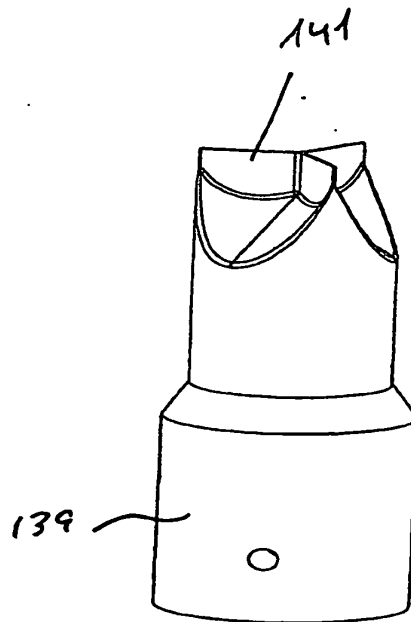
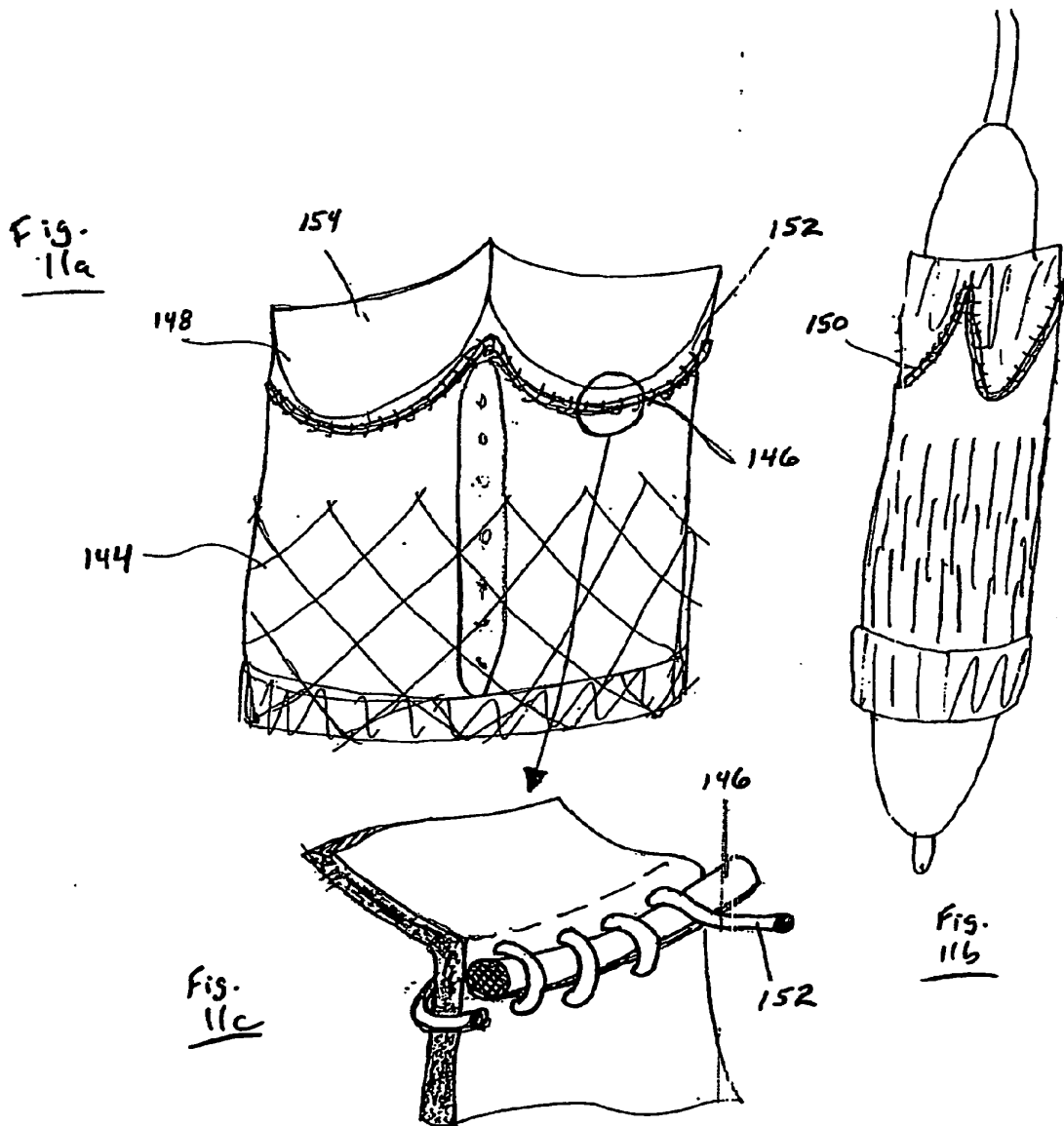


Fig. 9i

FIG 10





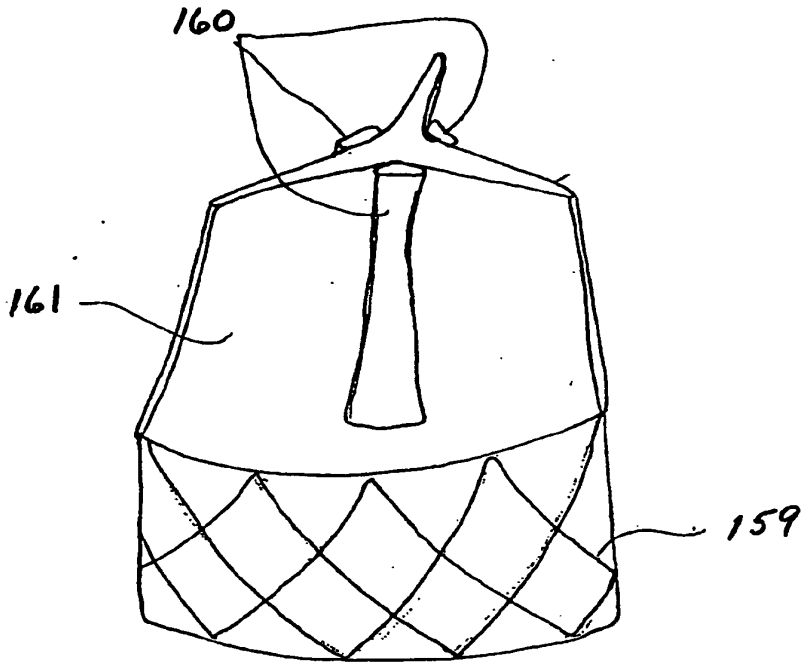


Fig. 129

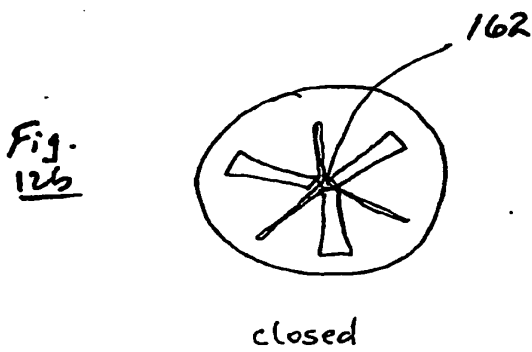


Fig. 12b

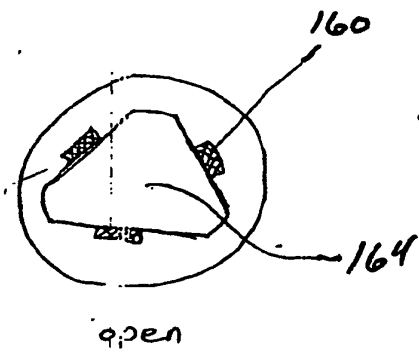


Fig. 12c

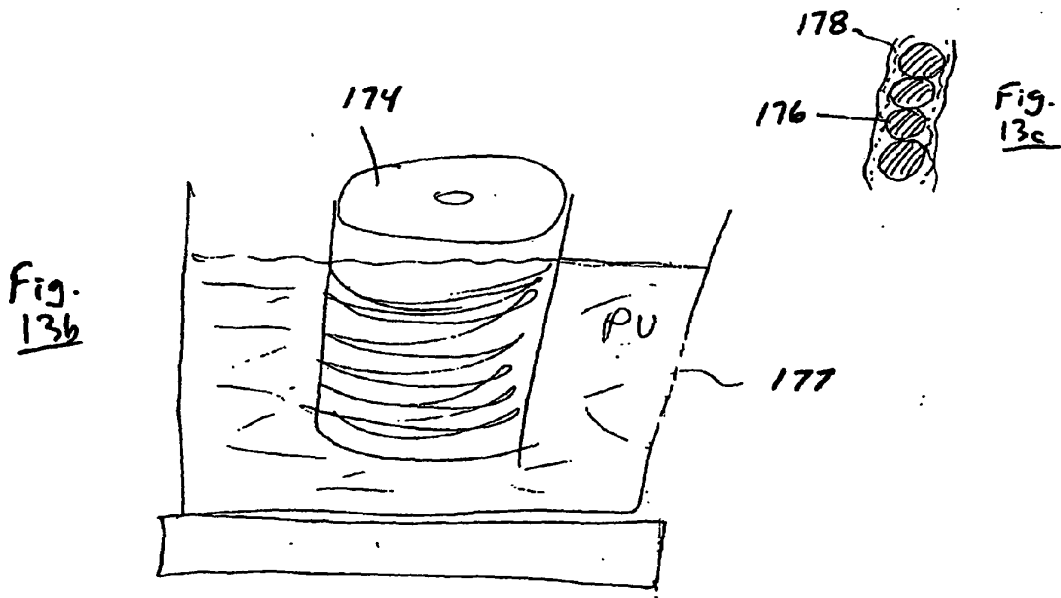
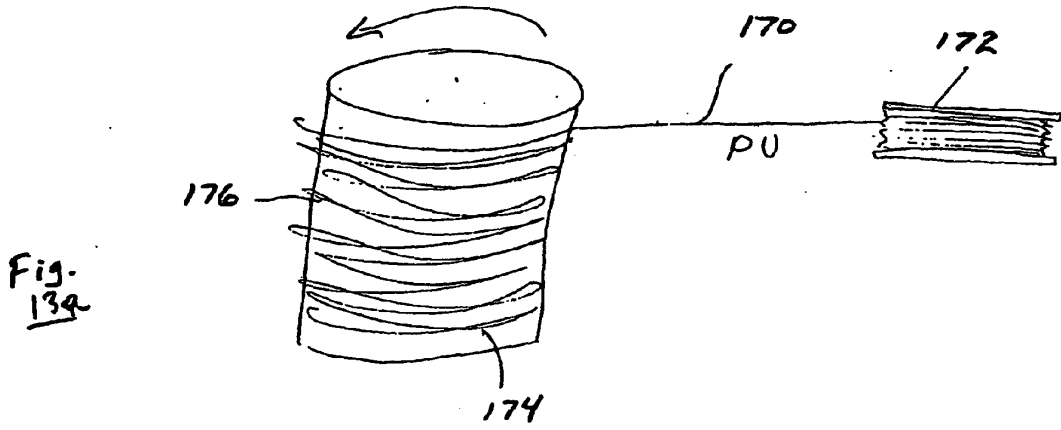


FIG 14

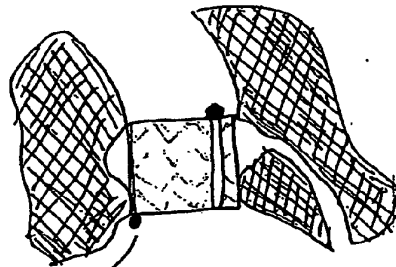
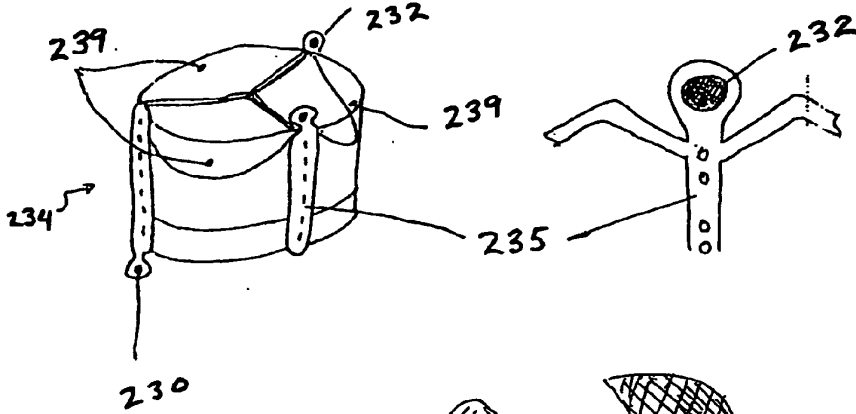
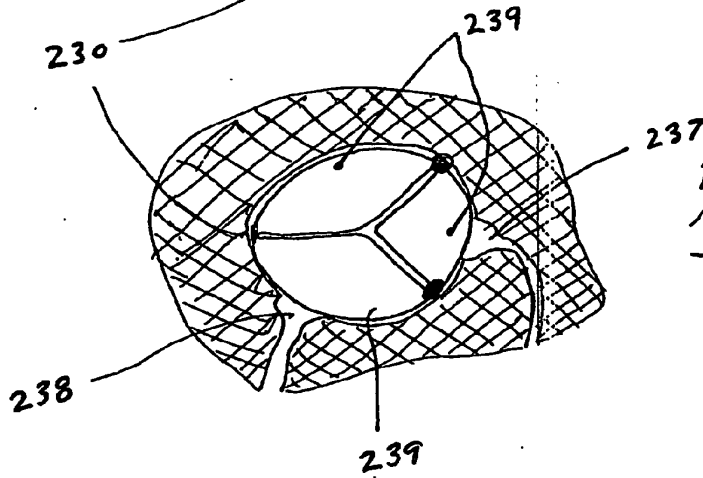
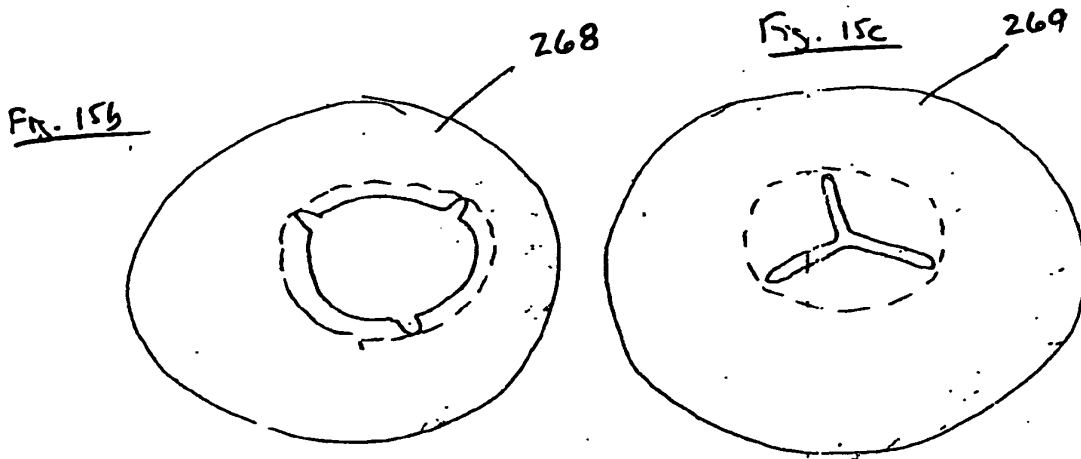
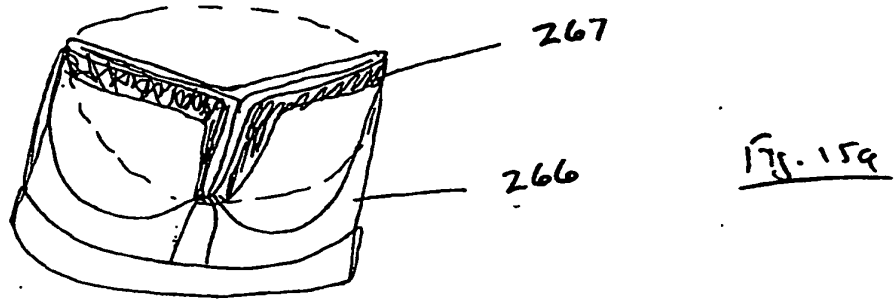


Fig. 14b







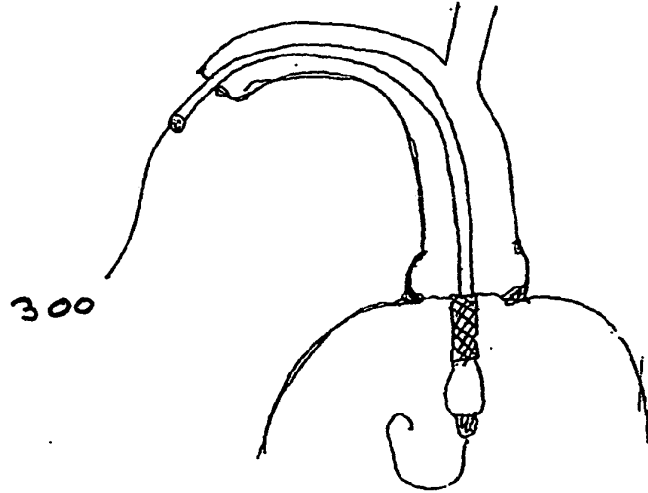


Fig. 16a

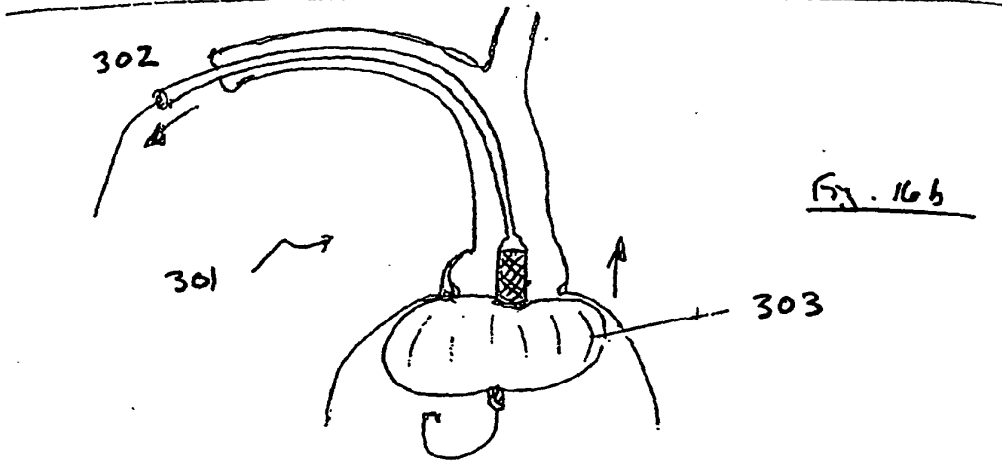


Fig. 16b

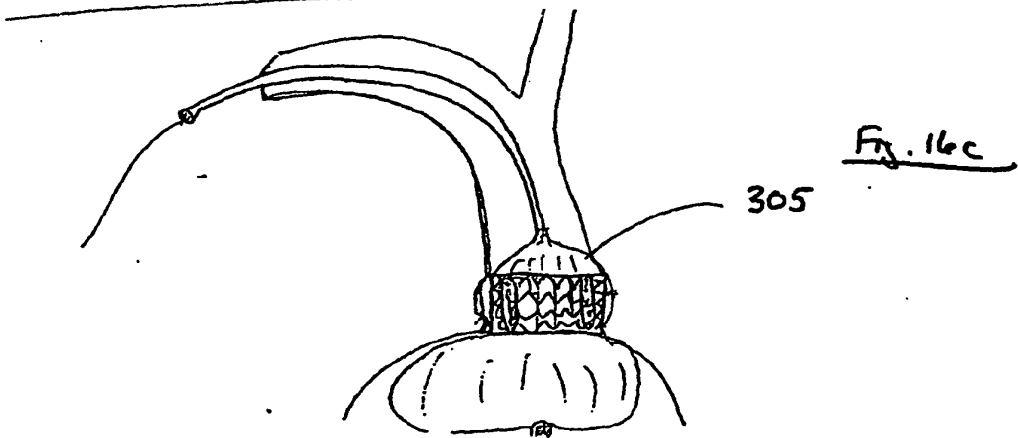
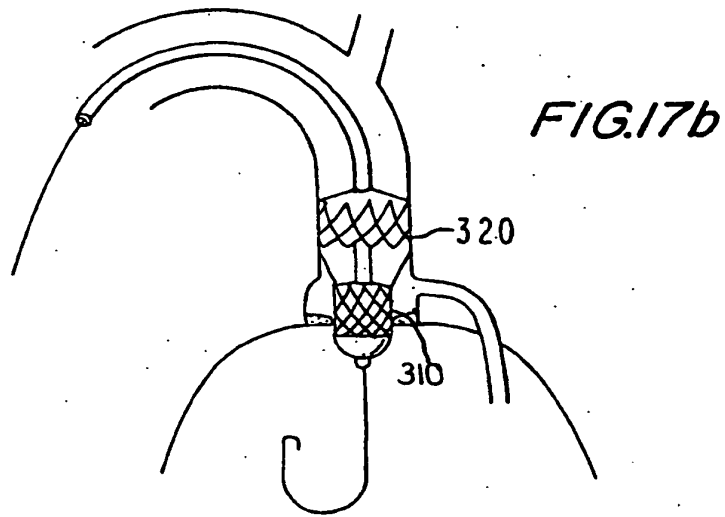
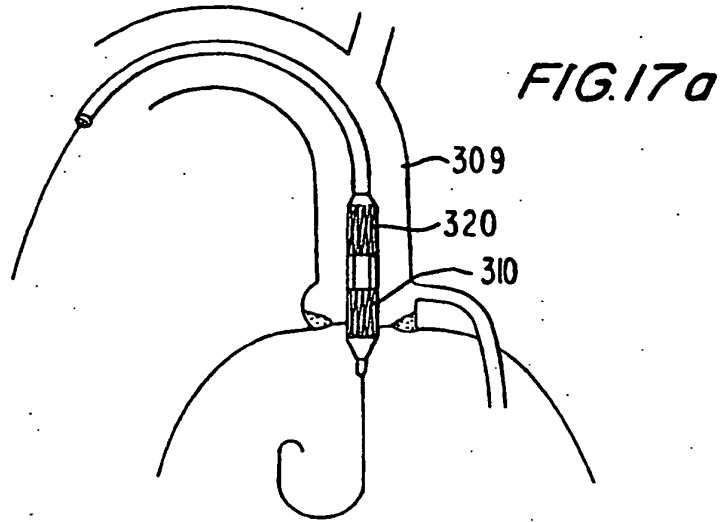
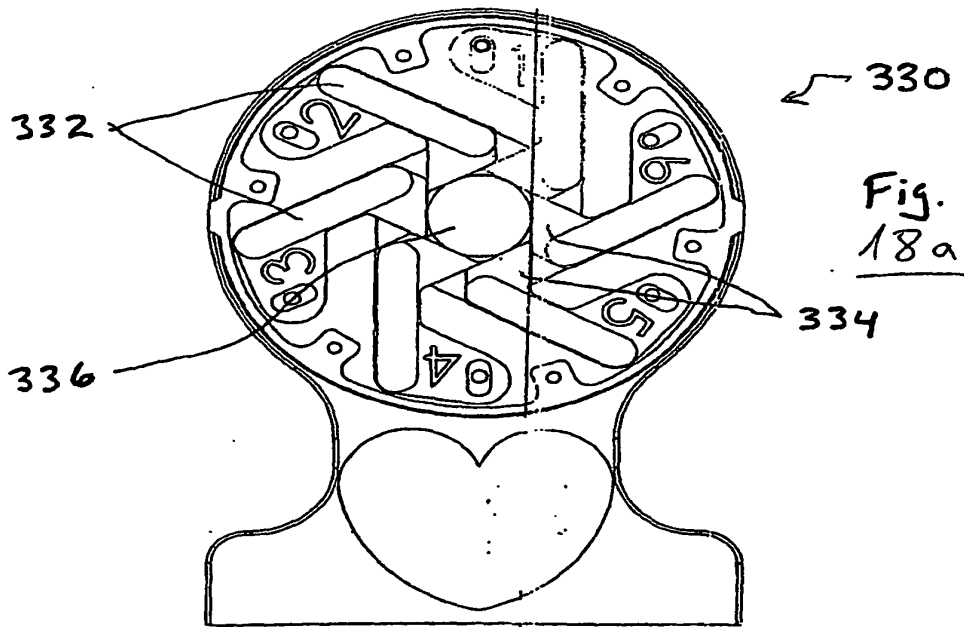
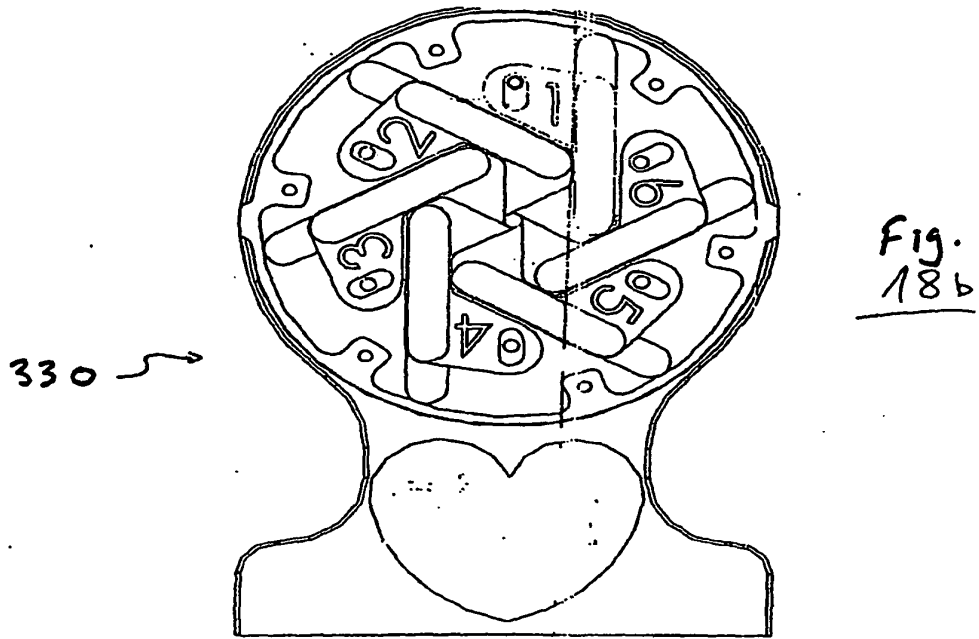


Fig. 16c





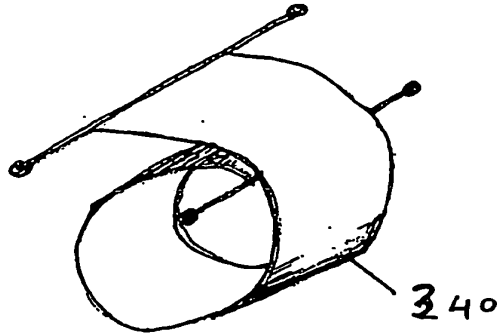


Fig. 19a

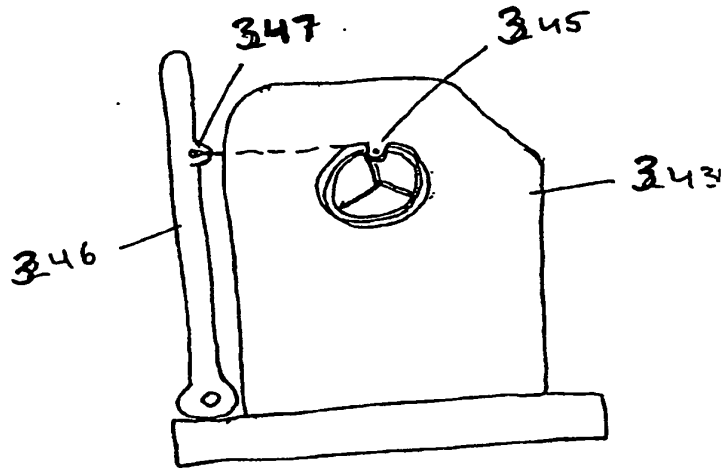


Fig. 19b

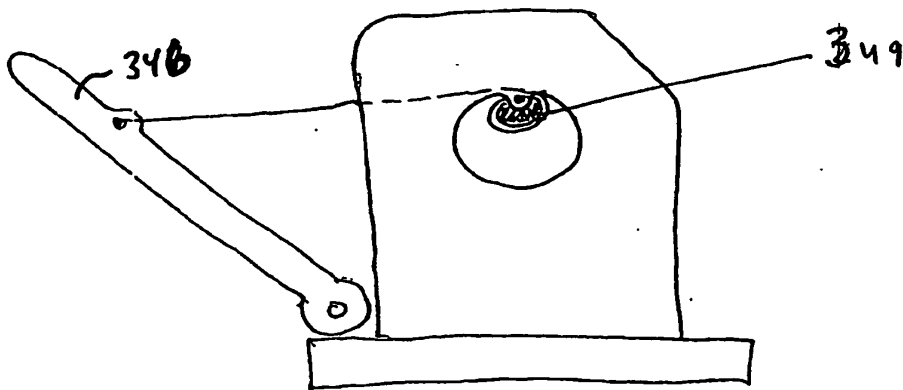


Fig. 19c

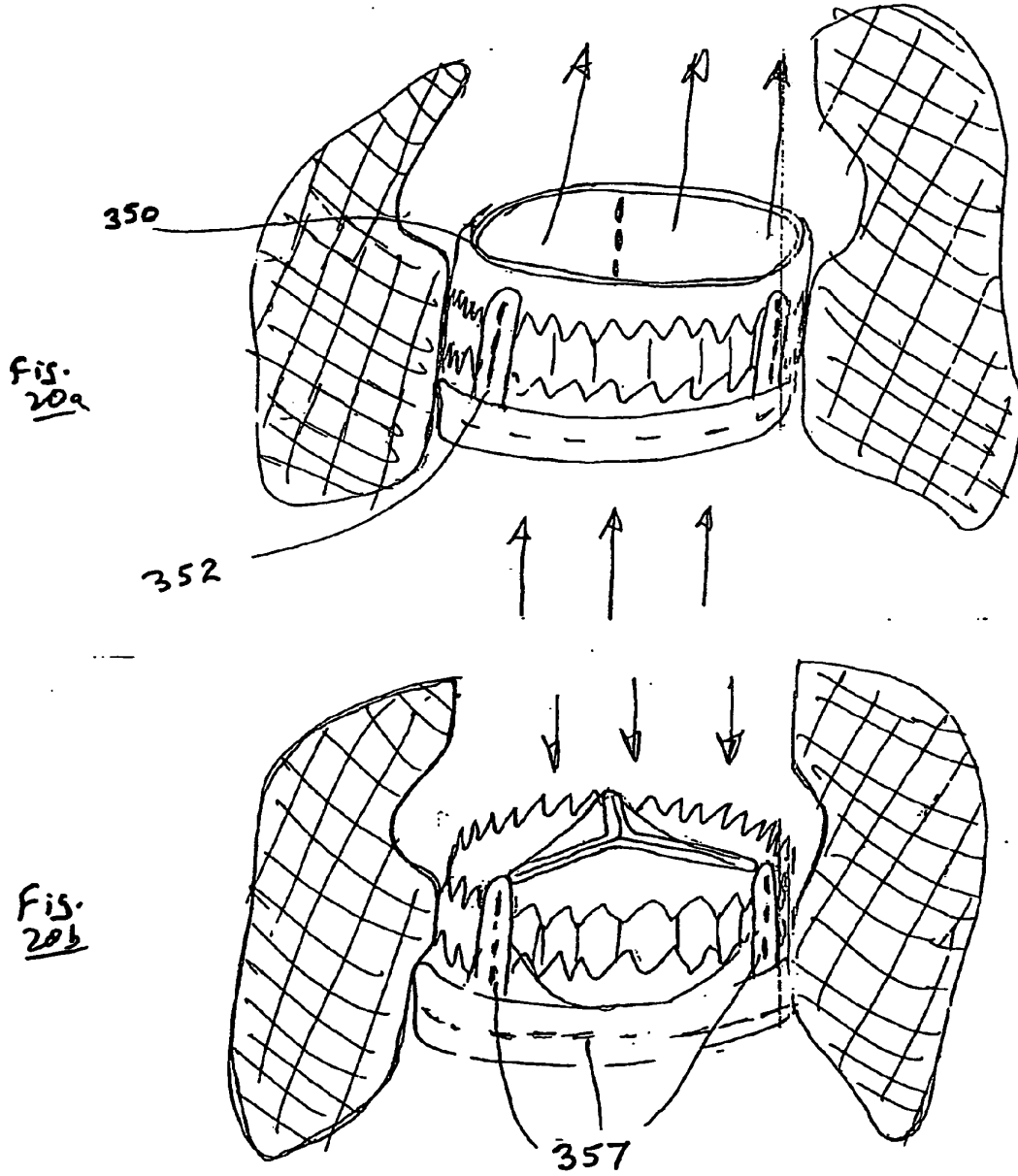


FIG 21

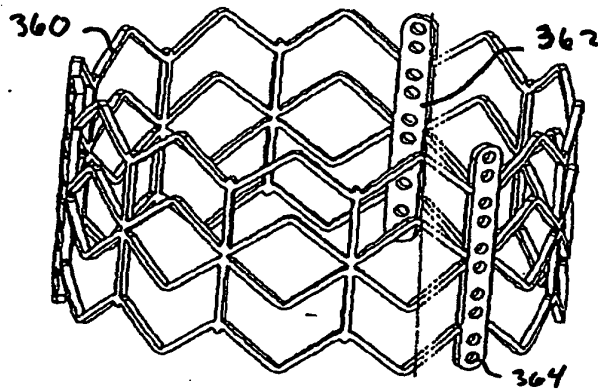


FIG 22

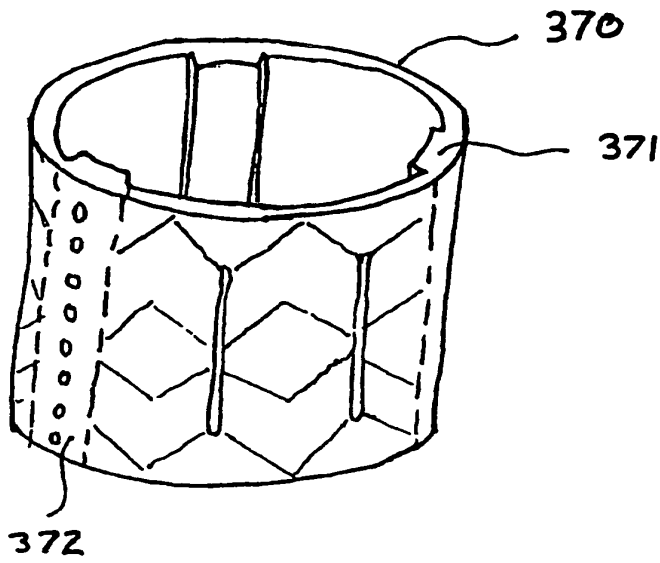






Fig. 23a

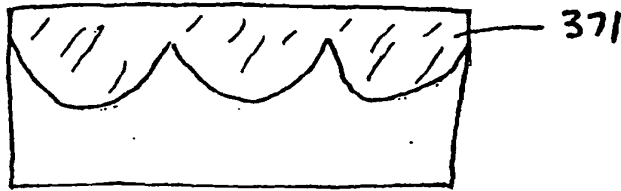


Fig. 23b

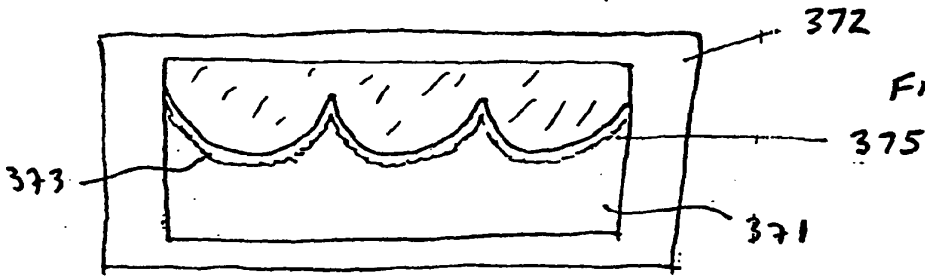


Fig. 23c

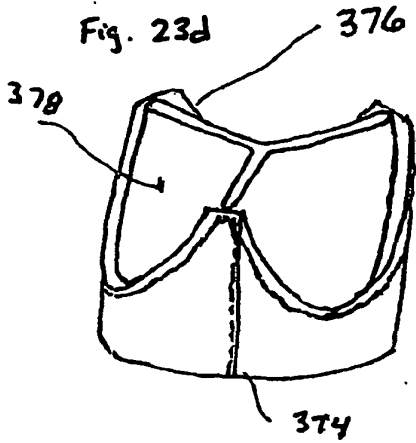


Fig. 23d

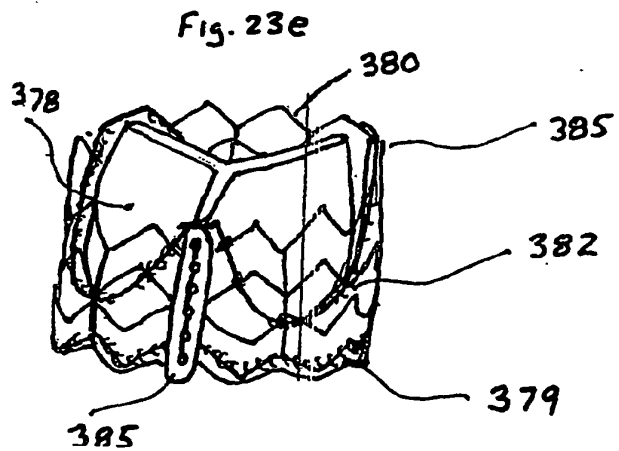


Fig. 23e

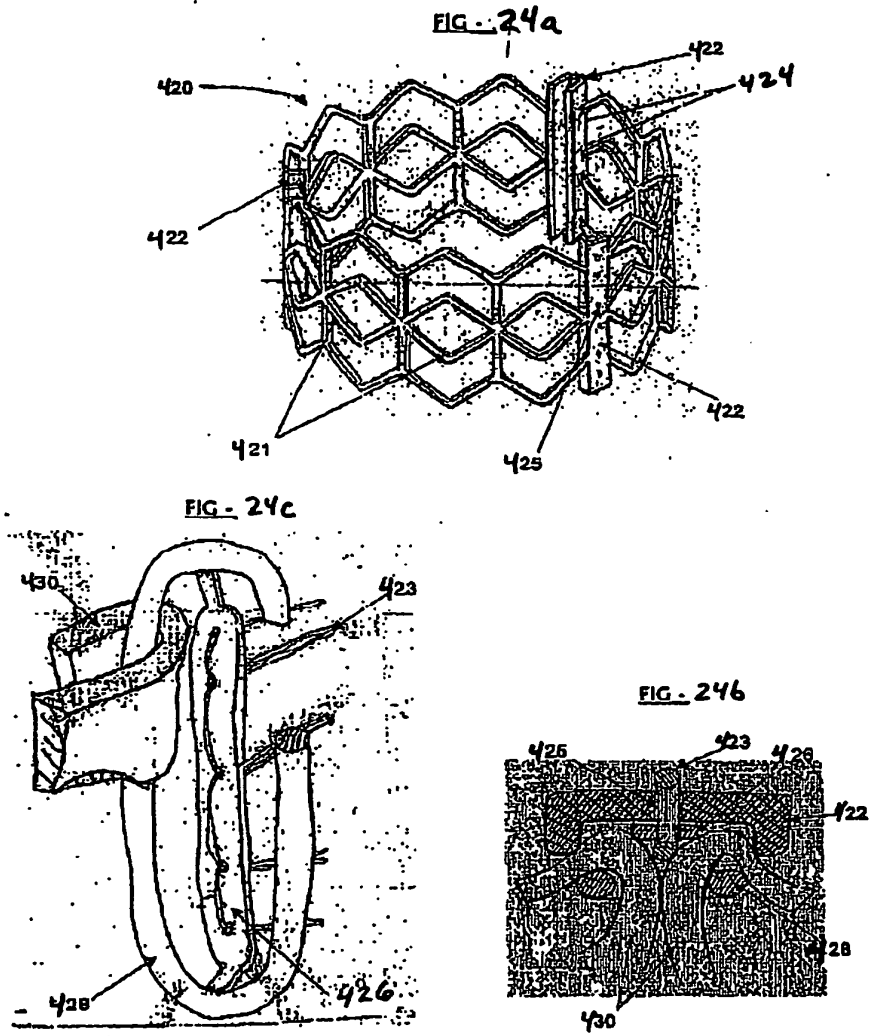


FIG. 25c

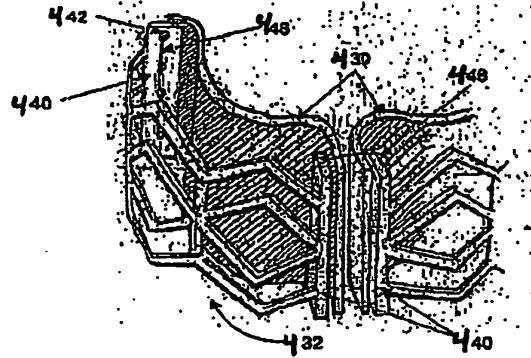


FIG. 25b

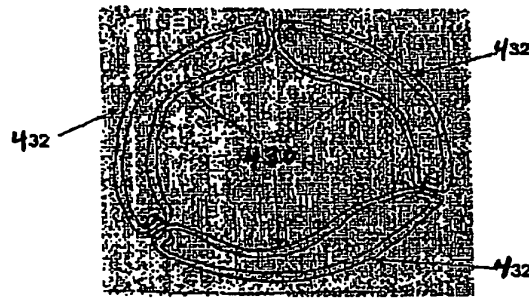


FIG. 25e



FIG. 25d

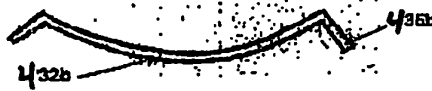


FIG-26a

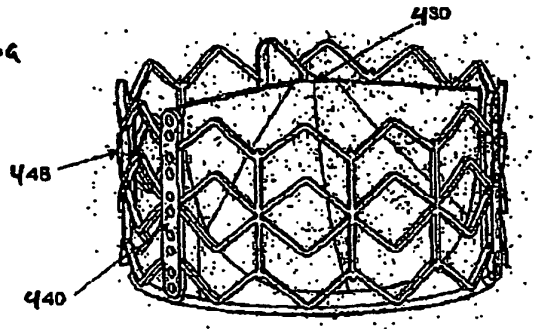


FIG-26b

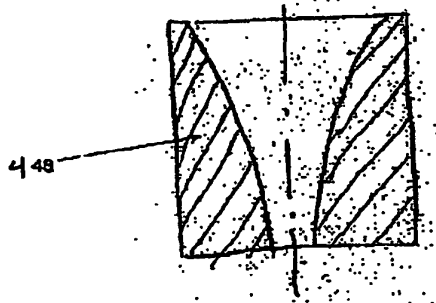
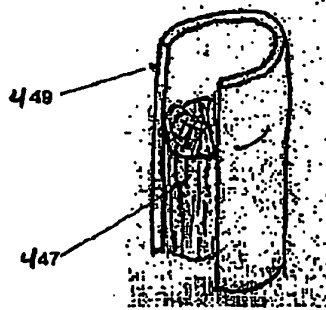


FIG-26c



**FIG. 27**

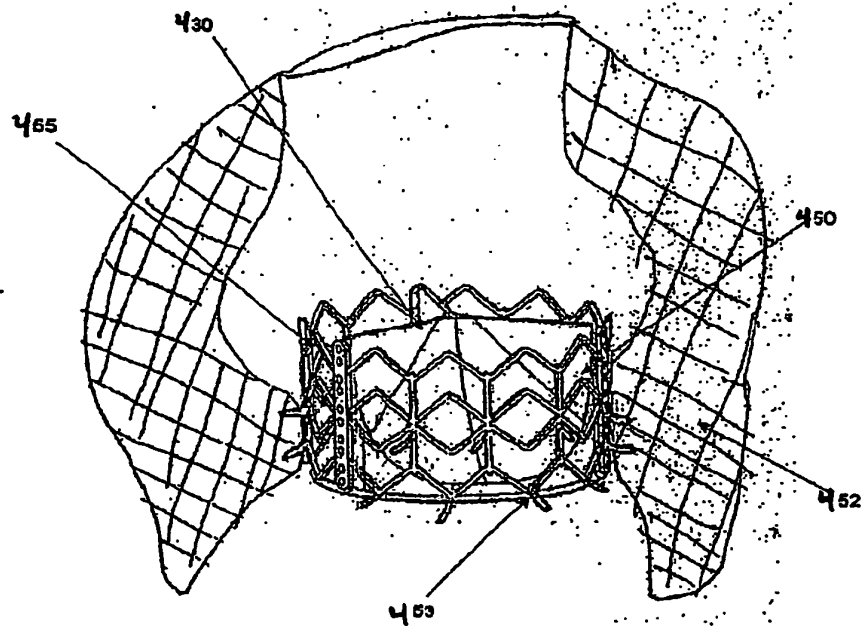


FIG. 28

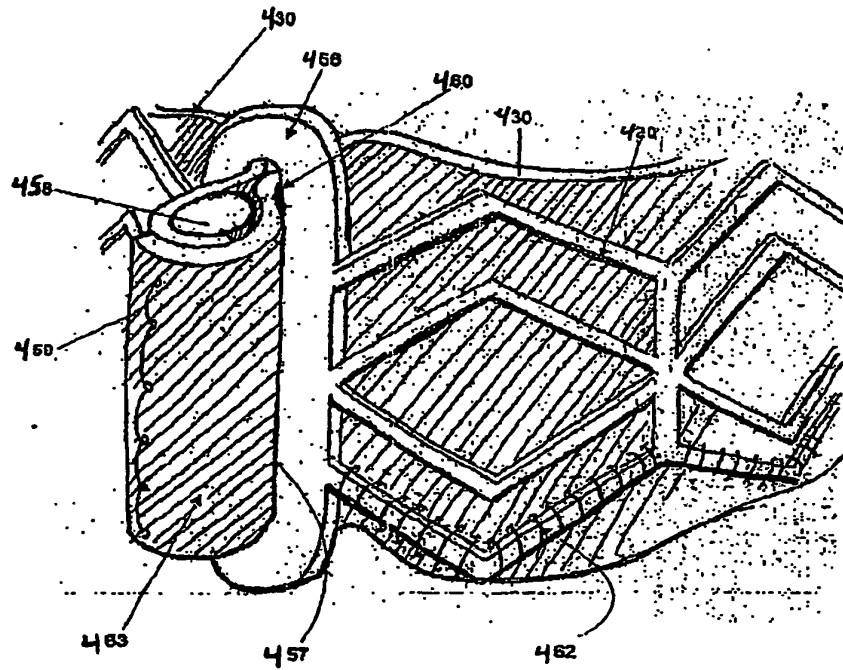


FIG - 29a

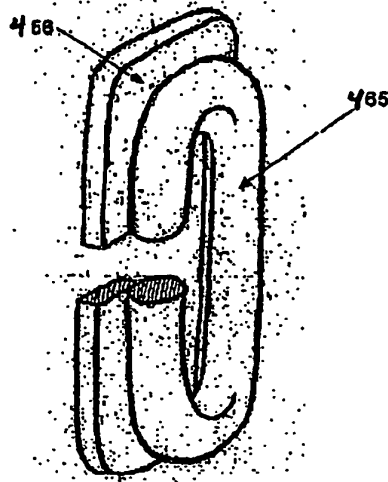
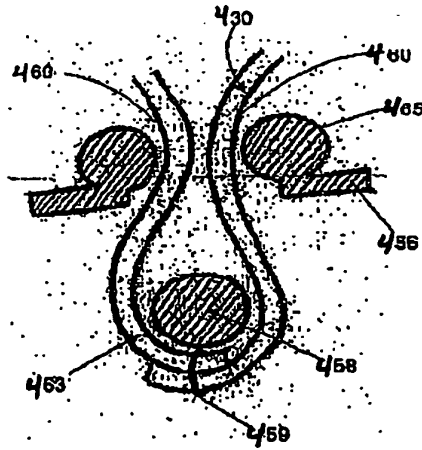


FIG - 29b



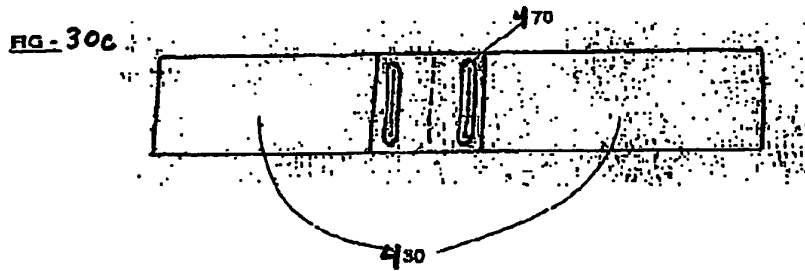
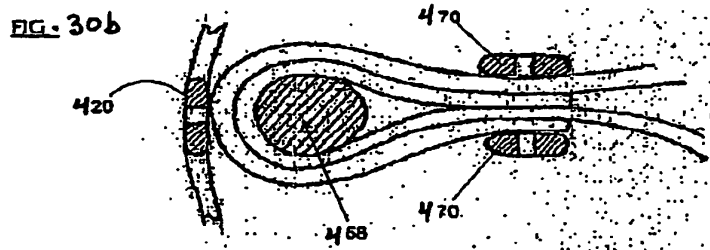
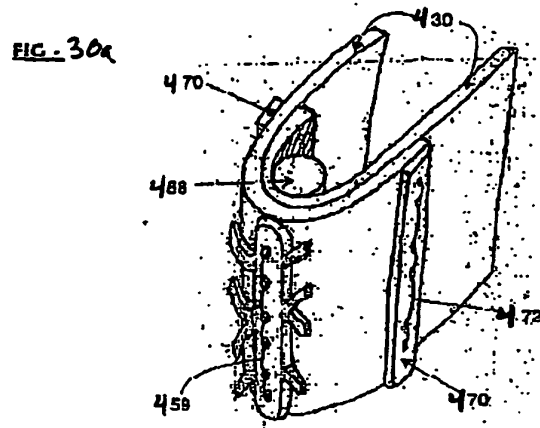




FIG. 31a

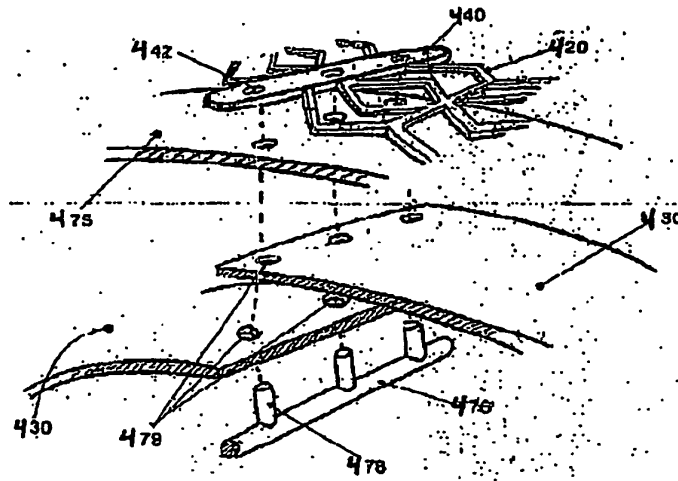
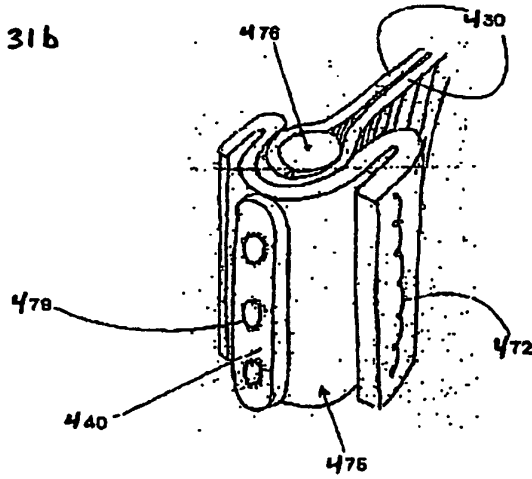


FIG. 31b



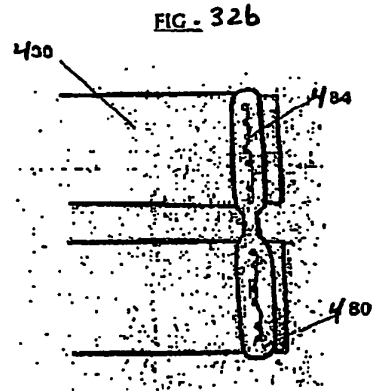
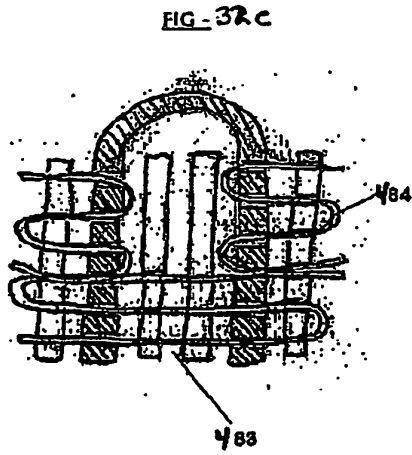
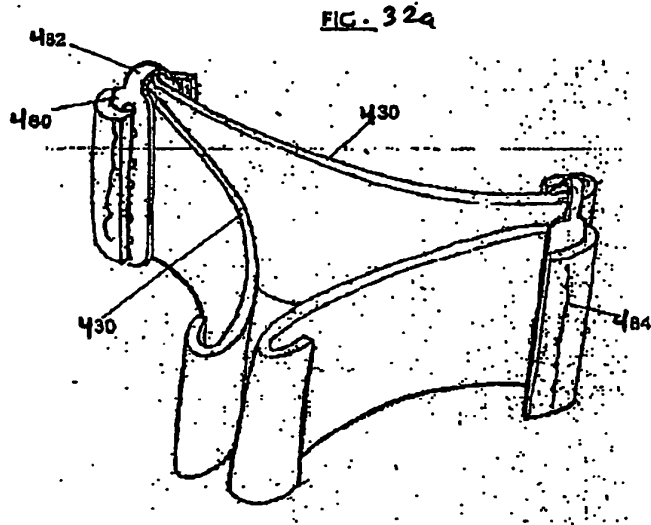


FIG. 33a

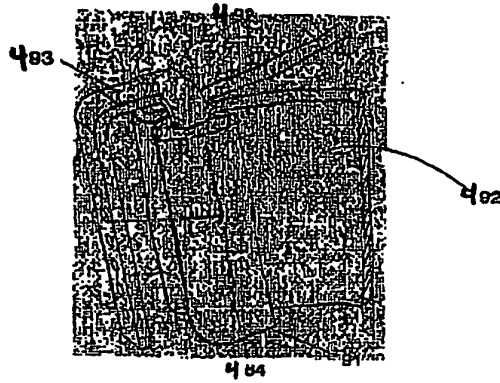


FIG. 33b

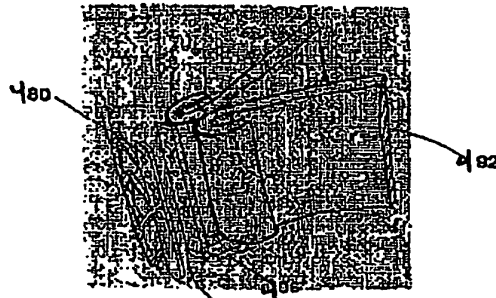
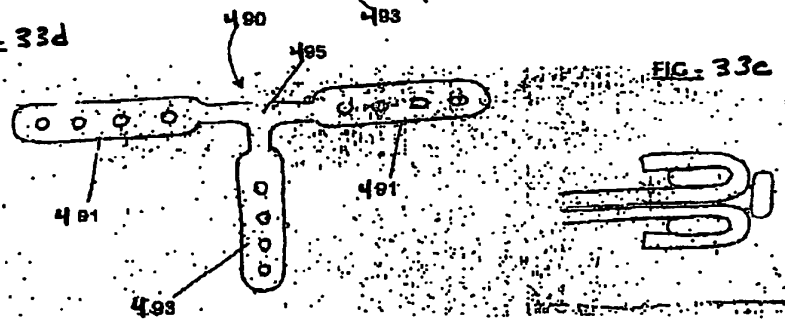
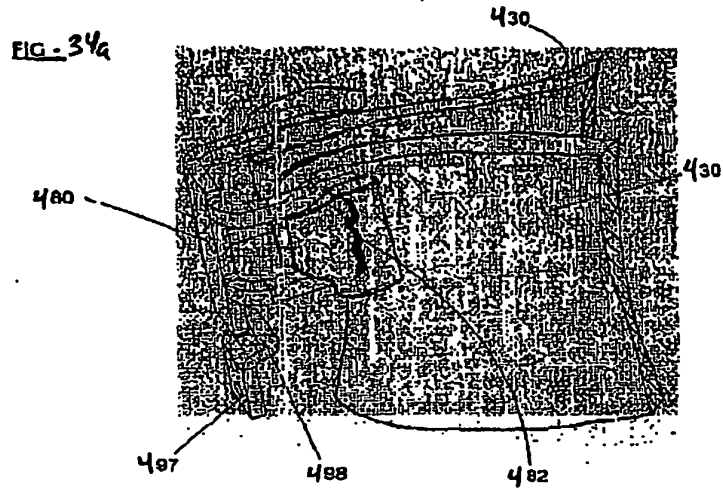
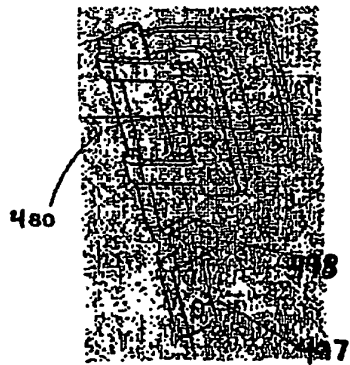


FIG. 33d





**FIG. 34c**



**FIG. 34b**

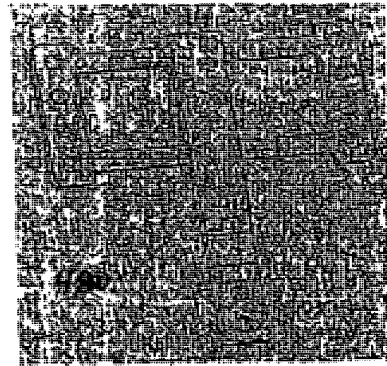


FIG. 35a

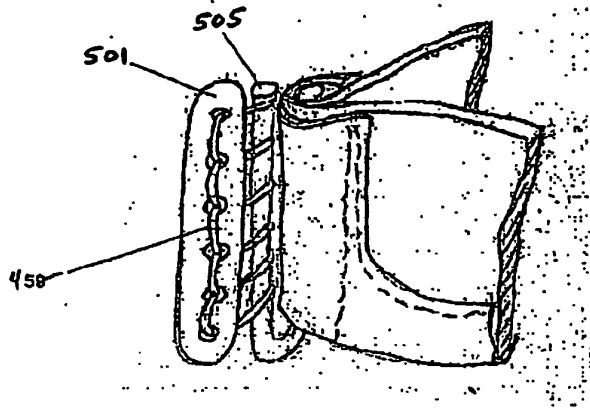


FIG. 35b

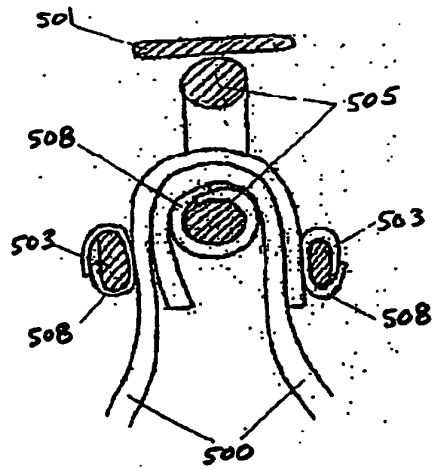
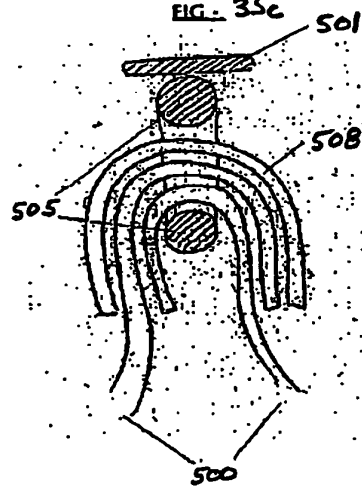


FIG. 35c



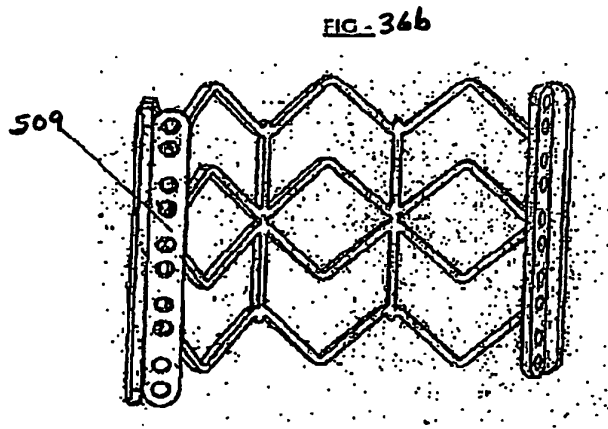
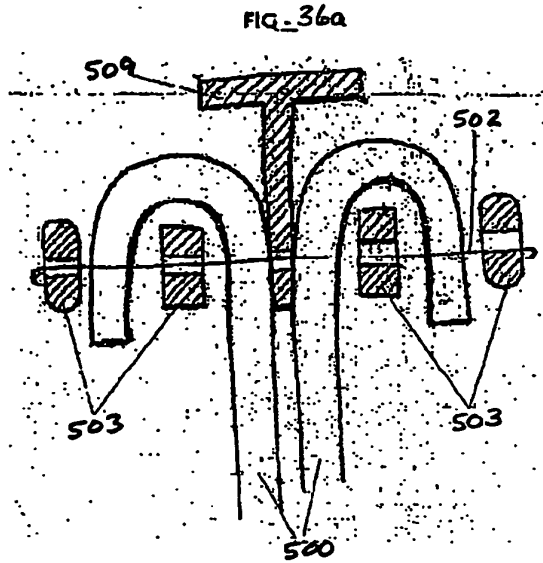


FIG. 37a

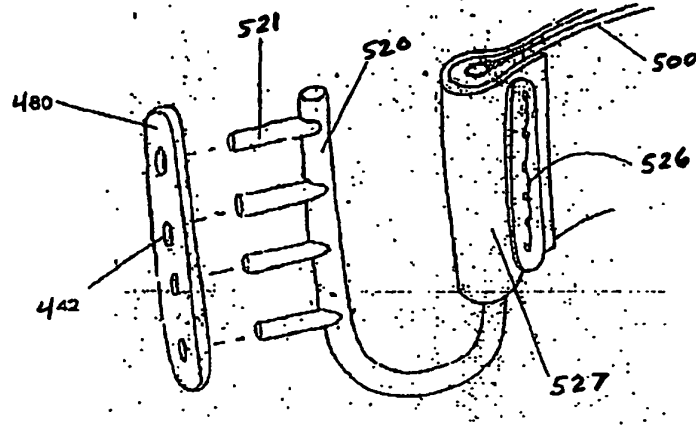


FIG. 37b

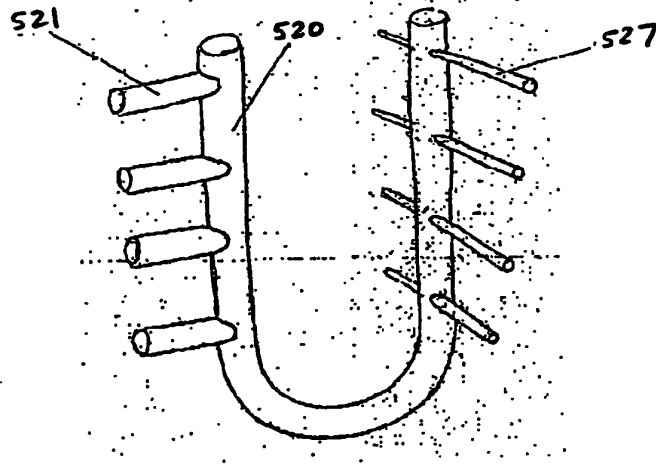
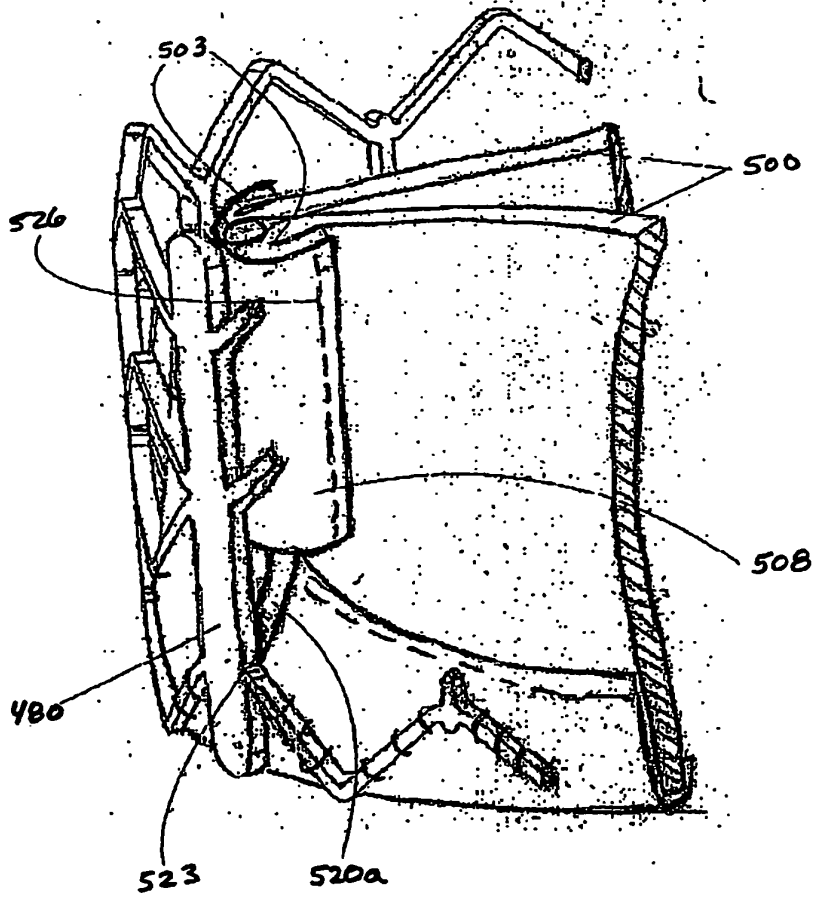
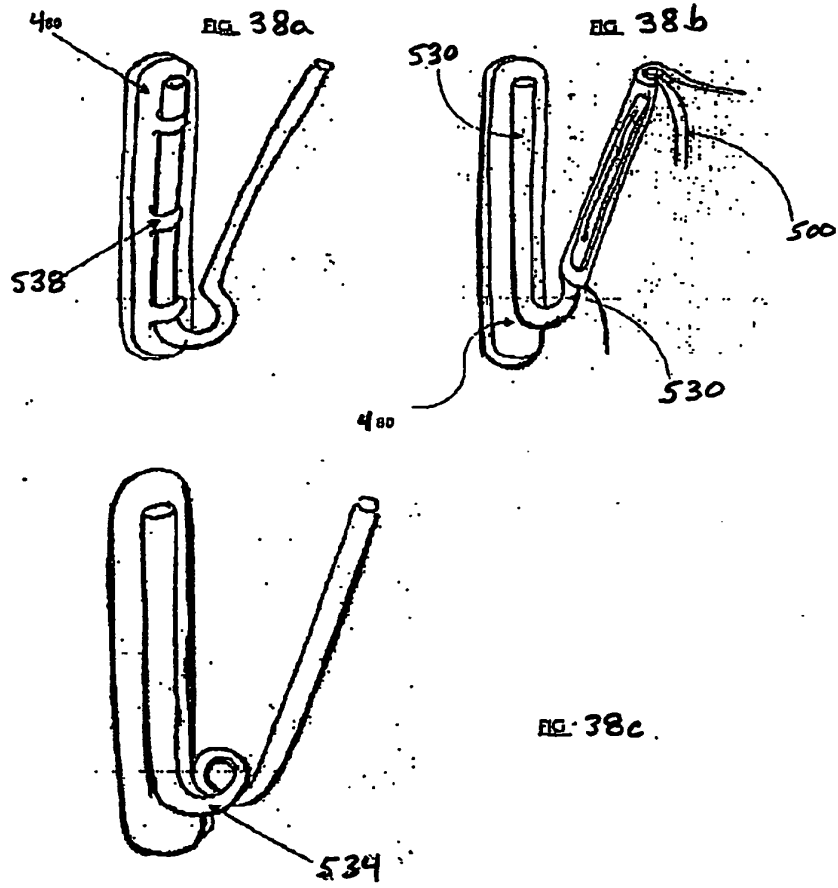
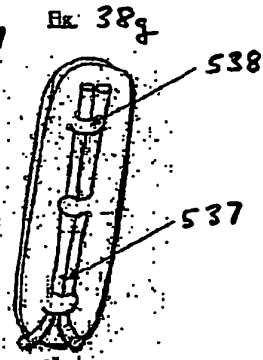
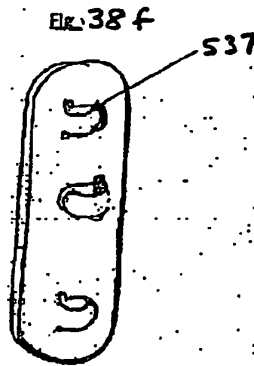
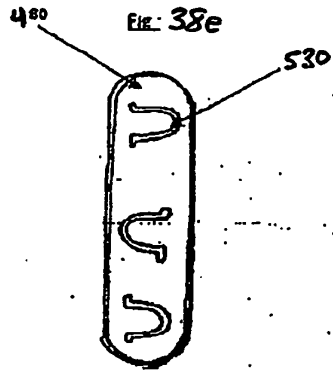
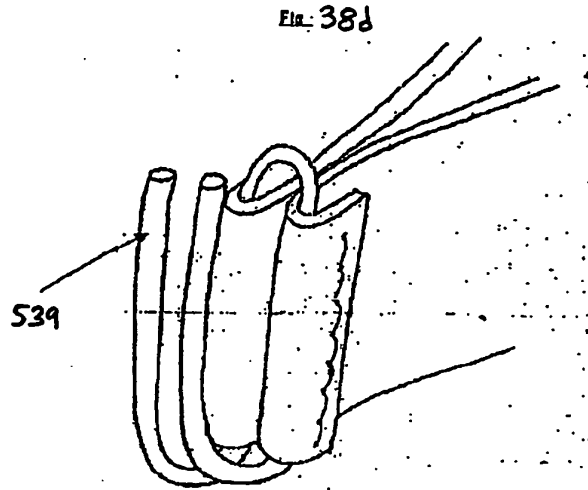


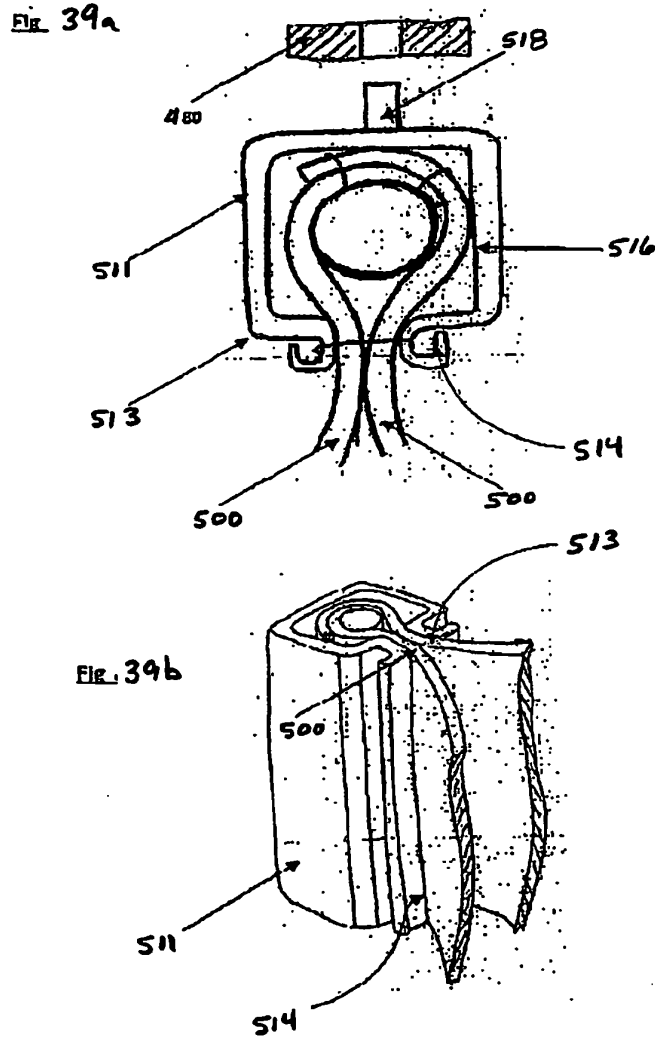
FIG. 37c











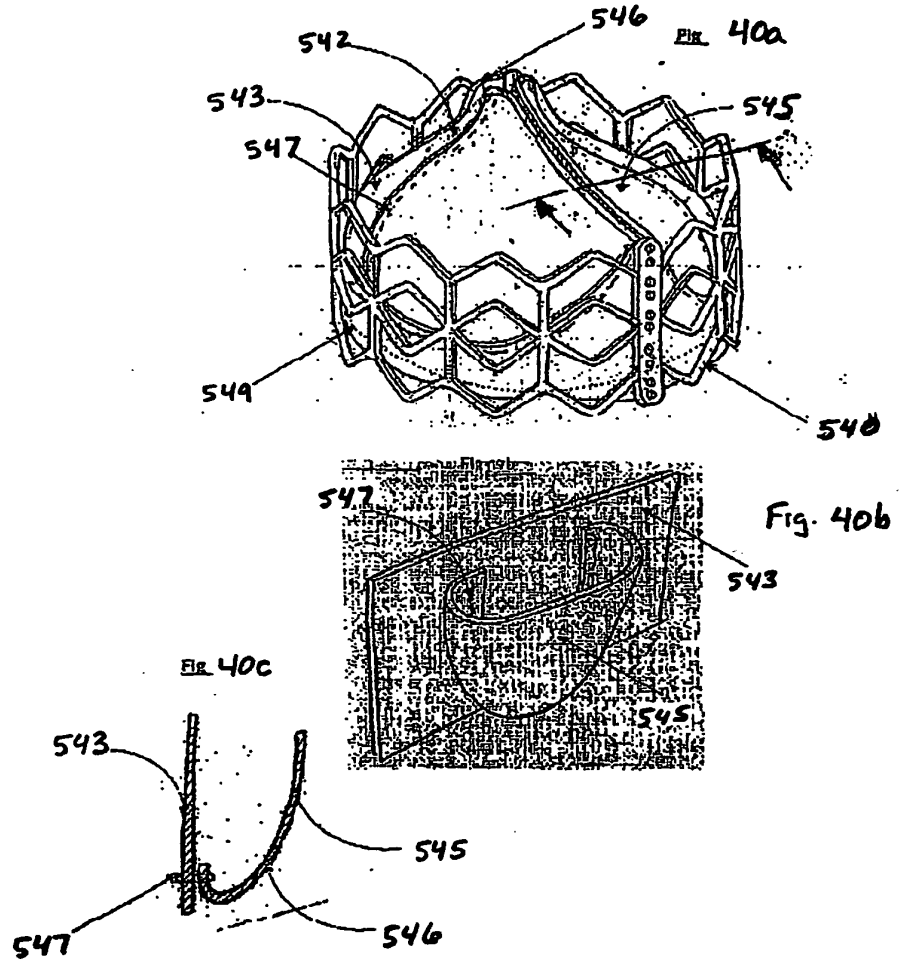


FIG. 41a

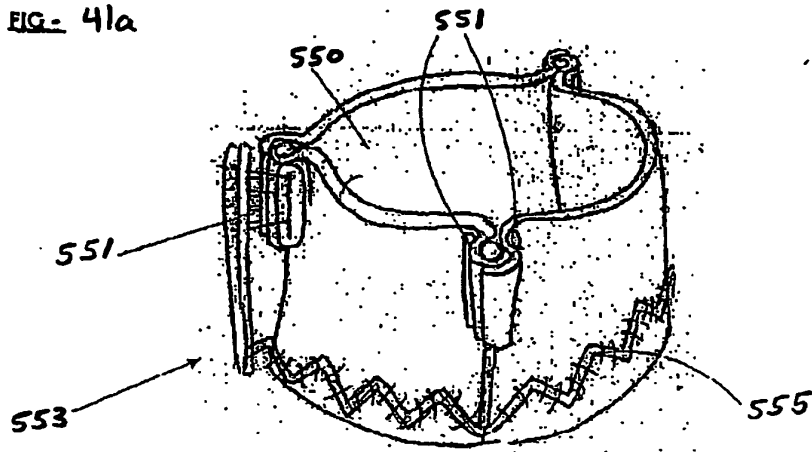
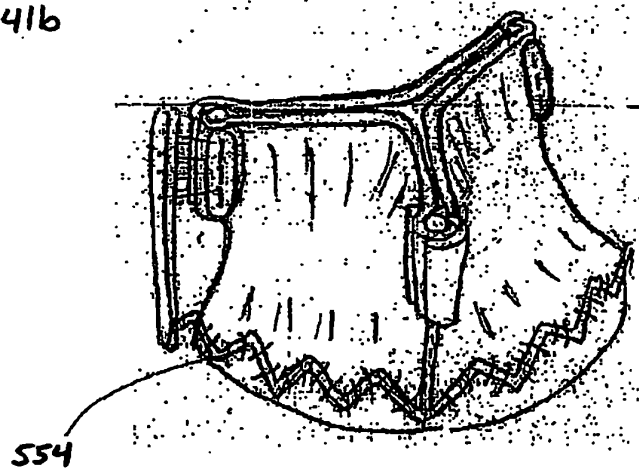
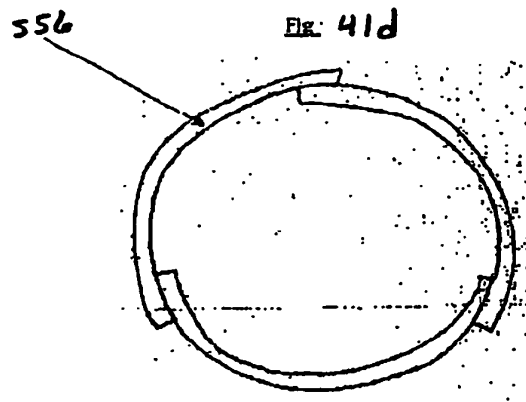
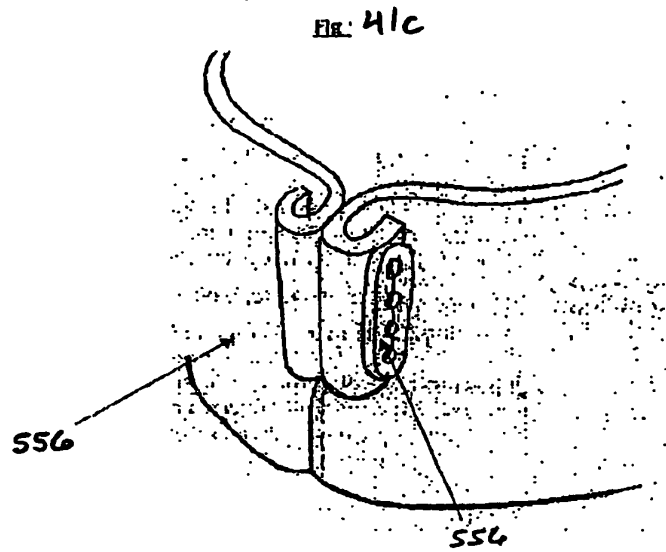
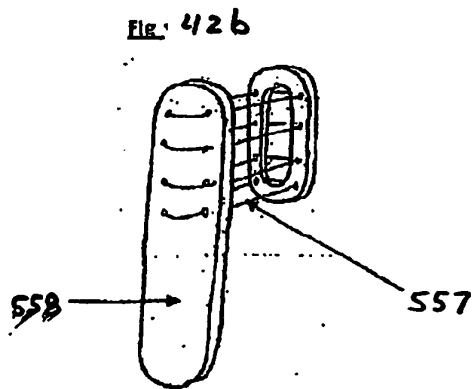
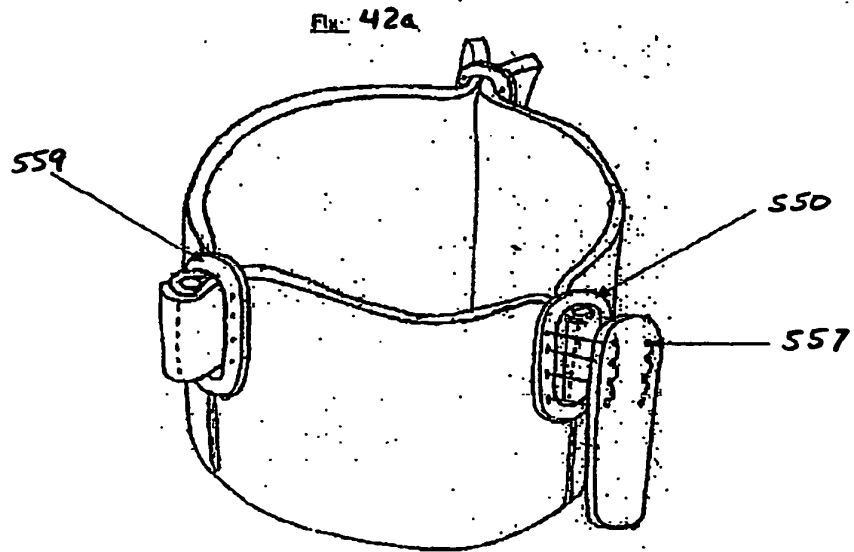


FIG. 41b







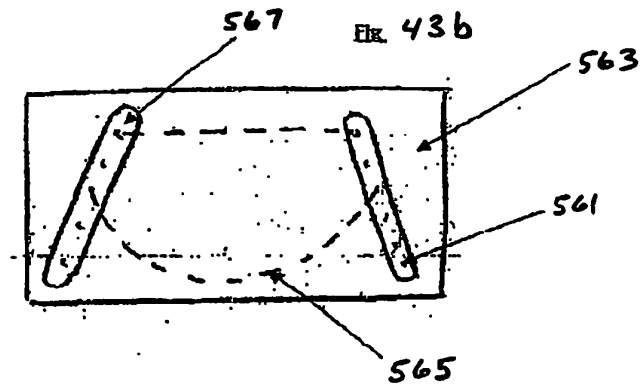
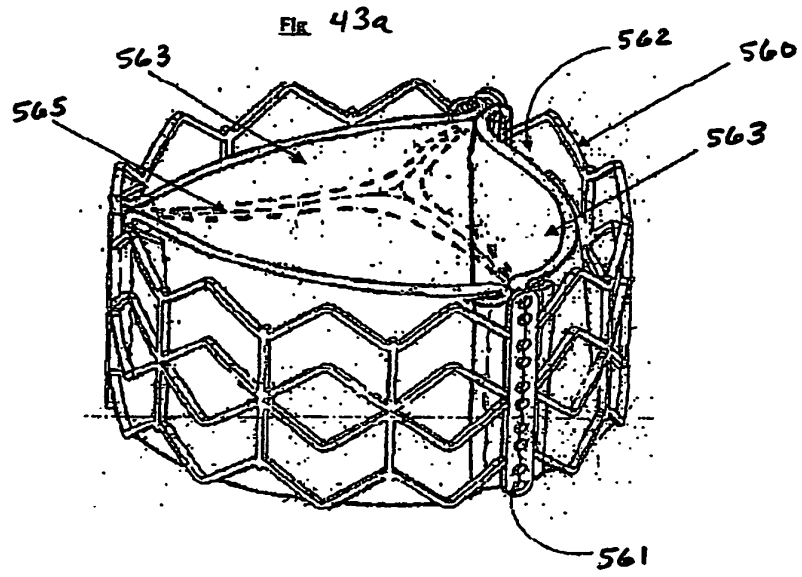




Fig. 44a

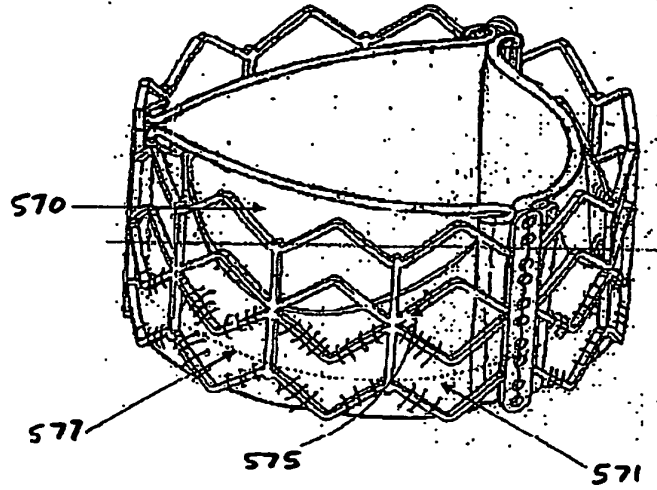


Fig. 44b

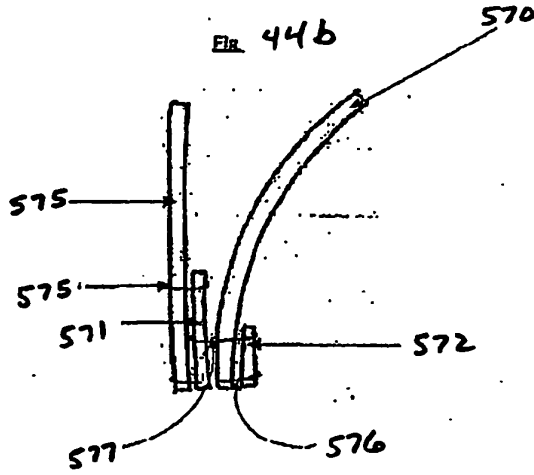


Fig. 44c



FIG. 45a

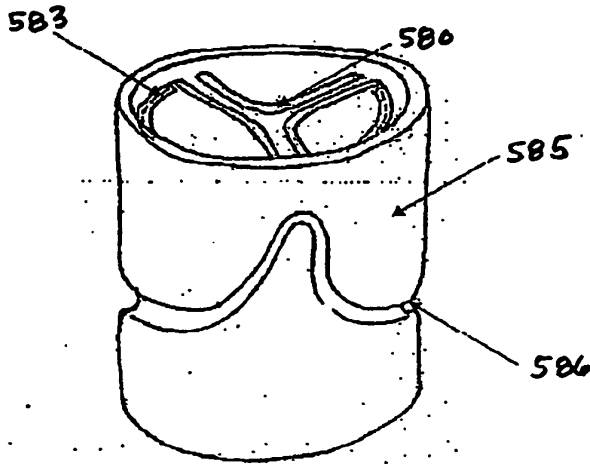


FIG. 45b

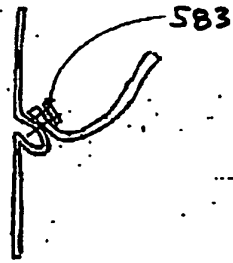


FIG. 45c

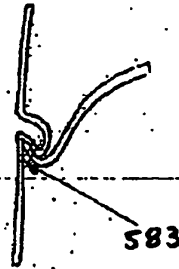
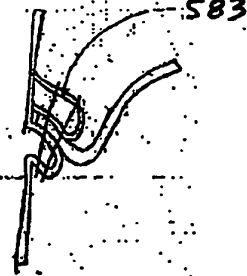


FIG. 45d



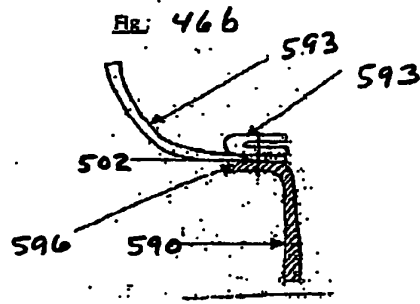
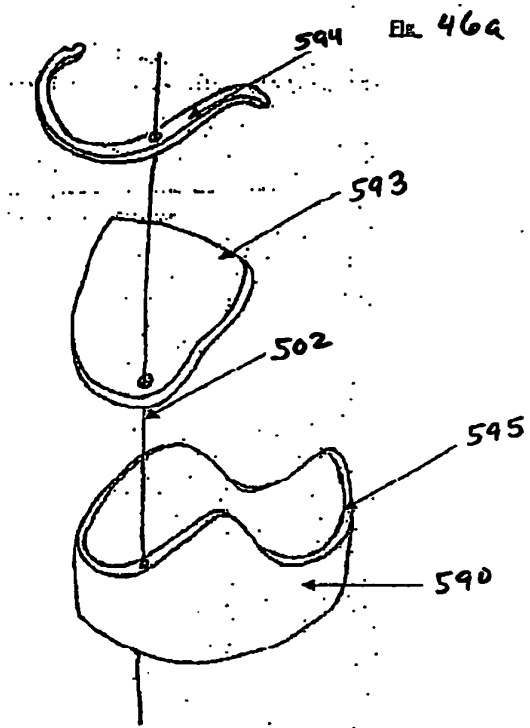


FIG- 47a

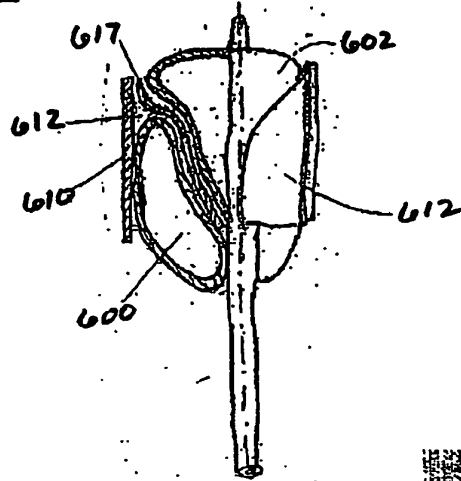


FIG- 47b

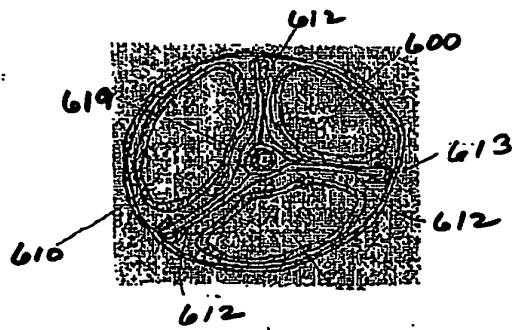


FIG- 47c



FIG. 48a

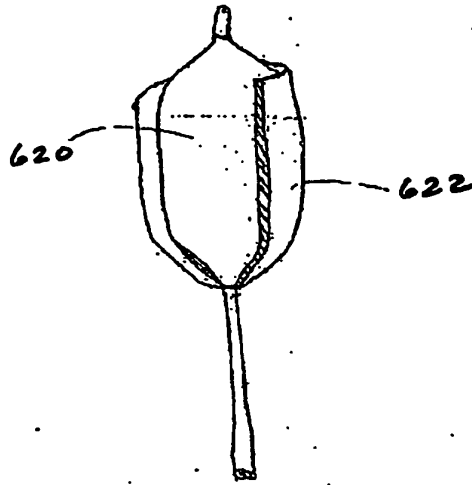
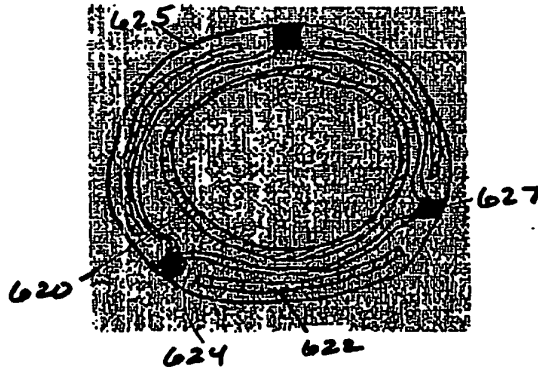


FIG. 48b



**EP 2 055 266 B1**

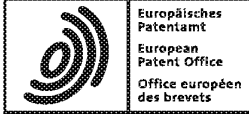
**REFERENCES CITED IN THE DESCRIPTION**

*This list of references cited by the applicant is for the reader's convenience only. It does not form part of the European patent document. Even though great care has been taken in compiling the references, errors or omissions cannot be excluded and the EPO disclaims all liability in this regard.*

**Patent documents cited in the description**

- US 5411552 A, Andersen **[0002]**
- US 6168614 B, Andersen **[0002]**
- US 5840081 A, Andersen **[0002]**
- EP 9707337 W, Letac, Cribier **[0003]**
- WO 9829057 A **[0003]**
- FR 2815844 A1 **[0009]**

(19)



(11)

**EP 2 260 796 B1**

(12)

**EUROPEAN PATENT SPECIFICATION**

(45) Date of publication and mention of the grant of the patent:  
**20.02.2013 Bulletin 2013/08**

(51) Int Cl.:  
**A61F 2/24 (2006.01) B60K 37/06 (2006.01)**

(21) Application number: **10012626.7**

(22) Date of filing: **31.12.1997**

**(54) A prosthetic valve assembly for implantation in a stenotic native aortic valve**

Klappenprothesenanordnung zur Implantation in eine stenotische natürliche Aortenklappe

Ensemble contenant une prothèse valvulaire pour l'implantation dans une valve aortique naturelle sténosée

(84) Designated Contracting States:  
**DE ES FR IT NL**

(30) Priority: **31.12.1996 EP 96402929**

(43) Date of publication of application:  
**15.12.2010 Bulletin 2010/50**

(62) Document number(s) of the earlier application(s) in accordance with Art. 76 EPC:  
**08016624.2 / 2 000 115**  
**05024006.8 / 1 621 162**  
**97953935.0 / 0 967 939**

(73) Proprietor: **Edwards Lifesciences PVT, Inc.**  
**Irvine, CA 92614 (US)**

(72) Inventors:  
 • **Cribier, Alain**  
**76570 Pavilly (FR)**  
 • **Letac, Brice**  
**. (FR)**

(74) Representative: **Müller-Boré & Partner**  
**Patentanwälte**  
**Grafinger Straße 2**  
**81671 München (DE)**

(56) References cited:  
**WO-A-93/01768 US-A- 3 548 417**  
**US-A- 3 657 744 US-A- 4 629 459**  
**US-A- 5 332 402**

**EP 2 260 796 B1**

Note: Within nine months of the publication of the mention of the grant of the European patent in the European Patent Bulletin, any person may give notice to the European Patent Office of opposition to that patent, in accordance with the Implementing Regulations. Notice of opposition shall not be deemed to have been filed until the opposition fee has been paid. (Art. 99(1) European Patent Convention).

## Description

**[0001]** The present invention relates to a prosthetic valve assembly or replacing a stenotic native aortic valve to be implanted by a transcatheterization technique.

**[0002]** The valve prosthesis can be also applied to other body channels provided with native valves, such as veins or in organs (liver, intestine, urethra,...).

**[0003]** The present description also discloses a method for implanting a valve prosthesis, such as the valve according to the present invention.

**[0004]** Implantable valves, which will be indifferently designated hereafter as "IV", "valve prosthesis" or "prosthetic valve", permits the reparation of a valvular defect by a less invasive technique in place of the usual surgical valve implantation which, in the case of valvular heart diseases, requires thoracotomy and extracorporeal circulation. A particular use for the IV concerns patients who cannot be operated on because of an associated disease or because of very old age or also patients who could be operated on but only at a very high risk.

**[0005]** Although the IV of the present invention and the process for implanting said IV can be used in various heart valve diseases, the following description will first concern the aortic orifice in aortic stenosis, more particularly in its degenerative form in elderly patients.

**[0006]** Aortic stenosis is a disease of the aortic valve in the left ventricle of the heart. The aortic valvular orifice is normally capable of opening during systole up to 4 to 6 cm<sup>2</sup>, therefore allowing free ejection of the ventricular blood volume into the aorta. This aortic valvular orifice can become tightly stenosed, and therefore the blood cannot anymore be freely ejected from the left ventricle. In fact, only a reduced amount of blood can be ejected by the left ventricle which has to markedly increase the intra-cavitary pressure to force the stenosed aortic orifice. In such aortic diseases, the patients can have syncope, chest pain, and mainly difficulty in breathing. The evolution of such a disease is disastrous when symptoms of cardiac failure appear, since 50 % of the patients die in the year following the first symptoms of the disease.

**[0007]** The only commonly available treatment is the replacement of the stenosed aortic valve by a prosthetic valve via surgery: this treatment moreover providing excellent results. If surgery is impossible to perform, i.e., if the patient is deemed inoperable or operable only at a too high surgical risk, an alternative possibility is to dilate the valve with a balloon catheter to enlarge the aortic orifice. Unfortunately, a good result is obtained only in about half of the cases and there is a high restenosis rate, i.e., about 80% after one year.

**[0008]** Aortic stenosis is a very common disease in people above seventy years old and occurs more and more frequently as the subject gets older. As evidenced, the present tendency of the general evolution of the population is becoming older and older. Also, it can be evaluated, as a crude estimation, that about 30 to 50% of the

subjects who are older than 80 years and have a tight aortic stenosis, either cannot be operated on for aortic valve replacement with a reasonable surgical risk or even cannot be considered at all for surgery.

**[0009]** It can be estimated that, about 30 to 40 persons out of a million per year, could benefit from an implantable aortic valve positioned by a catheterization technique. Until now, the implantation of a valve prosthesis for the treatment of aortic stenosis is considered unrealistic to perform since it is deemed difficult to superpose another valve such an implantable valve on the distorted stenosed native valve without excising the latter.

**[0010]** From 1985, the technique of aortic valvuloplasty with a balloon catheter has been introduced for the treatment of subjects in whom surgery cannot be performed at all or which could be performed only with a prohibitive surgical risk. Despite the considerable deformation of the stenosed aortic valve, commonly with marked calcification, it is often possible to enlarge significantly the aortic orifice by balloon inflation, a procedure which is considered as low risk.

**[0011]** However, this technique has been abandoned by most physicians because of the very high restenosis rate which occurs in about 80% of the patients within 10 to 12 months. Indeed, immediately after deflation of the balloon, a strong recoil phenomenon often produces a loss of half or even two thirds of the opening area obtained by the inflated balloon. For instance, inflation of a 20 mm diameter balloon in a stenosed aortic orifice of 0.5 cm<sup>2</sup> area gives, when forcefully and fully inflated, an opening area equal to the cross sectionnal area of the maximally inflated balloon, i.e., about 3 cm<sup>2</sup>. However, measurements performed a few minutes after deflation and removal of the balloon have only an area around 1 cm<sup>2</sup> to 1.2 cm<sup>2</sup>. This is due to the considerable recoil of the fibrous tissue of the diseased valve. The drawback in this procedure has also been clearly shown on fresh post mortem specimens.

**[0012]** However, it is important to note that whereas the natural normal aortic valve is able to open with an orifice of about 5 to 6 cm<sup>2</sup> and to accommodate a blood flow of more than 15 l/min. during heavy exercise for instance, an opening area of about 1.5 to 2 cm<sup>2</sup> can accept a 6 to 8 l/min blood flow without a significant pressure gradient. Such a flow corresponds to the cardiac output of the elderly subject with limited physical activity.

**[0013]** Therefore, an IV would not have to produce a large opening of the aortic orifice since an opening about 2 cm<sup>2</sup> would be sufficient in most subjects, in particular in elderly subjects, whose cardiac output probably does not reach more than 6 to 8 l/min. during normal physical activity. For instance, the surgically implanted mechanical valves have an opening area which is far from the natural valve opening that ranges from 2 to 2.5 cm<sup>2</sup>, mainly because of the room taken by the large circular structure supporting the valvular part of the device.

**[0014]** The prior art describes examples of cardiac valves prosthesis that are aimed at being implanted with-



out surgical intervention by way of catheterization. For instance, US patent n° 5,411,552 describes a collapsible valve able to be introduced in the body in a compressed presentation and expanded in the right position by balloon inflation.

**[0015]** Such valves, with a semi-lunar leaflet design, tend to imitate the natural valve. However, this type of design is inherently fragile, and such structures are not strong enough to be used in the case of aortic stenosis because of the strong recoil that will distort this weak structure and because they would not be able to resist the balloon inflation performed to position the implantable valve. Furthermore, this valvular structure is attached to a metallic frame of thin wires that will not be able to be tightly secured against the valve annulus. The metallic frame of this implantable valve is made of thin wires like in stents, which are implanted in vessels after balloon dilatation. Such a light stent structure is too weak to allow the implantable valve to be forcefully embedded into the aortic annulus. Moreover, there is a high risk of massive regurgitation (during the diastolic phase) through the spaces between the frame wires which is another prohibitive risk that would make this implantable valve impossible to use in clinical practice.

**[0016]** Furthermore, an important point in view of the development of the IV is that it is possible to maximally inflate a balloon placed inside the compressed implantable valve to expand it and insert it in the stenosed aortic valve up to about 20 to 23 mm in diameter. At the time of maximum balloon inflation, the balloon is absolutely stiff and cylindrical without any waist. At that moment, the implantable valve is squeezed and crushed between the strong aortic annulus and the rigid balloon with the risk of causing irreversible damage to the valvular structure of the implantable valve.

**[0017]** Document WO 93/01768 A discloses a valve replacement system provided for endovascular replacement of a heart valve in a host. A procedure device capsule comprises a cylindrical sleeve made of flexible durable material, e.g. teflon coated polyurethane or other materials which have the following characteristics: flexible such that it can be maneuvered through the vasculature, durable such that it can withstand the abrasive contact and pressure of instruments inserted and contained within it, and non-thrombogenic such that blood clots do not develop and adhere to its surface. The procedure device capsule has a generally cylindrical outside surface and a generally cylindrical inside surface with a mesh or grid design.

#### SUMMARY OF THE INVENTION

**[0018]** The invention is aimed to overcome these drawbacks and to implant an IV which will remain reliable for years.

**[0019]** A particular aim of the present invention is to provide an IV, especially aimed at being used in case of aortic stenosis, which structure is capable of resisting the

powerful recoil force and to stand the forceful balloon inflation performed to deploy the IV and to embed it in the aortic annulus.

**[0020]** Another aim of the present invention is to provide an efficient prosthesis valve which can be implanted by a catheterization technique, in particular in a stenosed aortic orifice, taking advantage of the strong structure made of the distorted stenosed valve and of the large opening area produced by preliminary balloon inflation, performed as an initial step of the procedure.

**[0021]** A further aim of the present invention is to provide an implantable valve which would not produce any risk of fluid regurgitation.

**[0022]** These aims are achieved according to the present invention which provides a valve prosthesis of the type mentioned in the introductory part and wherein said valve prosthesis comprises a collapsible continuous structure with guiding means providing stiffness and a frame to which said structure is fastened, said frame being strong enough to resist the recoil phenomenon of the fibrous tissue of the diseased valve.

**[0023]** The IV, which is strongly embedded, enables the implantable valve to be maintained in the right position without any risk of further displacement, which would be a catastrophic event.

**[0024]** More precisely, this valvular structure comprises a valvular tissue compatible with the human body and blood, which is supple and resistant to allow said valvular structure to pass from a closed state to an open state to allow a body fluid, more particularly the blood, exerting pressure on said valvular structure, to flow. The valvular tissue forms a continuous surface and is provided with guiding means formed or incorporated within, creating stiffened zones which induce the valvular structure to follow a patterned movement from its open position to its closed state and vice-versa, providing therefore a structure sufficiently rigid to prevent diversion, in particular into the left ventricle and thus preventing any regurgitation of blood into the left ventricle in case of aortic implantation.

**[0025]** Moreover, the guided structure of the IV allows the tissue of this structure to open and close with the same patterned movement while occupying as little space as possible in the closed state of the valve. Therefore, owing to these guiding means, the valvular structure withstands the unceasing movements under blood pressure changes during the heart beats.

**[0026]** More preferably, the valvular structure has a substantially truncated hyperboloidal shape in its expanded position, with a larger base and a growing closer neck, ending in a smaller extremity forming the upper part of the valvular structure. The valvular structure has a curvature at its surface that is concave towards the aortic wall. Such a shape produces a strong and efficient structure in view of the systolo-diastolic movement of the valvular tissue. Such a valvular structure with its simple and regular shape also lowers the risk of being damaged by forceful balloon inflation at the time of IV deployment.

**[0027]** A trunco-hyperboloidal shape with a small diameter at the upper extremity facilitates the closure of the valve at the beginning of diastole in initiating the starting of the reverse movement of the valvular tissue towards its base. Another advantage of this truncated hyperboloidal shape is that the upper extremity of the valvular structure, because of its smaller diameter, remains at a distance from the coronary ostia during systole as well as during diastole, thus offering an additional security to ensure not to impede at all the passage of blood from the aorta to the coronary ostia.

**[0028]** As another advantageous example, the guiding means of the valvular structure are inclined strips from the base to the upper extremity of the valvular structure with regard to the central axis of the valvular structure. This inclination initiates and imparts a general helicoidal movement of the valvular structure around said central axis at the time of closure or opening of said structure, such a movement enabling to help initiate and finalize the closure of the valvular structure. In particular, this movement improves the collapse of the valvular structure towards its base at the time of diastole and during the reversal of flow at the very beginning of diastole. During diastole, the valvular structure thus falls down, folding on itself and collapses on its base, therefore closing the aortic orifice. The strips can be pleats, strengthening struts or thickened zones.

**[0029]** In other examples, said guiding means are recitilinear strips from the base to the upper extremity of the valvular structure. In this case, the guiding means can comprise pleats, struts or thickened zones. In a particular example, the stiffened zones then created can be advantageously two main portions, trapezoidal in shape, formed symmetrically one to each other with regard to the central axis of the valvular structure, and two less rigid portions separating said two main portions to lead to a tight closeness in shape of a closed slot at the time of closure of the upper extremities of the main portions of the valvular structure. The thickened zones can be extended up to form the stiffened zones.

**[0030]** More particularly, each of said main slightly rigid portions occupy approximately one third of the circumference of the valvular structure when this latter is in its open position. The slightly rigid portions maintain the valvular structure closed during diastole by firmly applying themselves on each other. The closure of the valvular structure at the time of diastole thus does not have any tendency to collapse too much towards the aortic annulus.

**[0031]** Preferably, the guiding means are a number of pleats formed within the tissue by folding, or formed by recesses or grooves made in the tissue. The shape of the pleats is adapted to achieve a global shape of the desired type for said position.

**[0032]** Alternatively, the guiding means are made of strengthening struts, preferably at least three, incorporated in the tissue in combination or not with said pleats.

**[0033]** The guiding means and, in particular, the

strengthening struts, help to prevent the valvular tissue from collapsing back too much and to reverse inside the left ventricle through the base of the frame, preventing the risk of blood regurgitation.

**[0034]** Said valvular tissue is made of pericardium. This material is Commonly used in cardiac surgery and is quite resistant, particularly to folding movements due to the increasing systolo-diastolic movements of the valvular tissue and particularly at the junction with the frame of the implantable valve.

**[0035]** The valvular structure is fastened along a substantial portion of an expandable frame, by sewing, by molding or by gluing to exhibit a tightness sufficiently hermetical to prevent any regurgitation of said body fluid between the frame and the valvular structure.

**[0036]** An internal cover is sutured to the valvular structure and placed between said valvular structure and the internal wall of the frame to prevent any passage of the body fluid through said frame. Therefore, there is no regurgitation of blood as it would be the case if there were any space between the valvular structure fastened on the frame and the zone of application of the frame on the aortic annulus. The internal cover makes a sort of "sleeve" at least below the fastening of the valvular structure covering the internal surface of the frame and thus prevents any regurgitation of blood through the frame.

**[0037]** In the present invention, the frame is a substantially cylindrical structure capable of maintaining said body channel open in its expanded state and supporting said collapsible valvular structure.

**[0038]** In a preferred embodiment of the invention, the frame is made of a material which is distinguishable from biological tissue to be easily visible by non invasive imaging techniques.

**[0039]** Said frame is a stainless metal structure made of intercrossing, preferably with rounded and smooth linear bars. This frame is strong enough to resist the recoil phenomenon of the fibrous tissue of the diseased valve. The size of the bars and their number are determined to give both the maximal rigidity when said frame is expanded and the smallest volume when the frame is compressed.

**[0040]** More preferably, the frame has projecting curved extremities and presents a concave shape. This is aimed at reinforcing the embedding and the locking of the implantable valve in the distorted aortic orifice.

**[0041]** In a preferred example, the IV is made in two parts, a first reinforced frame coupled with a second frame which is made of thinner bars than said first frame and which is embedded inside the second frame. This second frame to which the valvular structure is fastened as described above, is preferably less bulky than the first frame to occupy as little space as possible and to be easily expanded using low pressure balloon inflation.

**[0042]** The present description also discloses a double balloon catheter to separately position the first frame in the dilated stenosed aortic valve and place the second frame that comprises the valvular structure. This catheter

comprises two balloons fixed on a catheter shaft and separated by few centimeters.

**[0043]** The first balloon is of the type sufficiently strong to avoid bursting even at a very high pressure inflation and is aimed at carrying, in its deflated state, a strong frame aimed at scaffolding the previously dilated stenosed aortic valve. The second balloon is aimed at carrying the second frame with the valvular structure.

**[0044]** An advantage of this double balloon catheter is that each balloon has an external diameter which is smaller than known balloons since each element to be expanded is smaller.

**[0045]** Moreover, such a double balloon catheter allows to enlarge the choice for making an efficient valvular structure enabling to overcome the following two contradictory conditions:

- 1) having a soft and mobile valvular structure capable of opening and closing freely in the blood stream, without risk of being damaged by balloon inflation; and
- 2) needing a very strong structure able to resist the recoil force of the stenosed valve and capable of resisting, without any damage, a strong pressure inflation of the expanding balloon.

**[0046]** Furthermore, the shaft of said double balloon catheter comprises two lumens for successive and separate inflation of each balloon. Of note, an additional lumen capable of allowing a rapid inflation takes additional room in the shaft.

**[0047]** The description also discloses a method of using a two-balloon catheter with a first frame and second frame to which a valve prosthesis of the type previously described is fastened.

#### DESCRIPTION OF THE DRAWINGS

**[0048]** The invention will now be explained and other advantages and features will appear with reference to the accompanying schematical drawings wherein :

- Figures 1a, 1b and 1c illustrate, in section views, respectively, the normal aortic valve in systole, in diastole and a stenosed aortic valve;
- Figures 2a and 2b illustrate two examples of a metallic frame which are combined to a valvular structure according to the present invention;
- Figures 3a and 3b illustrate a frame according to the invention in its expanded position with an opening out of the extremities, respectively, with a cylindrical and a concave shape;
- Figures 4a and b illustrate an IV respectively in its compressed position and in its expanded position in an open position as in systole;
- Figures 5a and 5b illustrate respectively an IV in its closed position and a sectional view according to the central axis of such a valvular structure which is

closed as in diastole;

- Figures 6a to 6d illustrate a sectional view according to the central axis of an IV according to the present invention and showing the internal cover and the external cover of the valvular structure overlapping partially or non overlapping the frame bars;
- Figure 7 illustrates the frontal zig-zag fastening line of the valvular tissue on the frame;
- Figures 8a and 8b illustrate, respectively, a perspective view of a valvular structure and an internal cover made all of one piece and a perspective view of the corresponding frame into which they will be inserted and fastened;
- Figures 9a and 9b illustrate inclined strengthening struts, an example of a valvular structure, respectively in the open position and in the closed position;
- Figures 10a and 10b illustrate an example of a valvular structure comprising pleats, respectively in the open and in the closed position;
- Figures 11 a and 11 b illustrate a valvular structure comprising two trapezoidal slightly rigid portions, respectively in the open and in the closed position;
- Figures 11c to 11e illustrate a valvular structure comprising a rectangular stiffened zone, respectively in the open, intermediate and closed position;
- Figures 12a and 12b illustrate, respectively, a perspective and cross sectional views of an implantable valve in its compressed presentation squeezed on a balloon catheter;
- Figures 13a to 13l illustrate views of the successive procedure steps for the IV implantation in a stenosed aortic orifice;
- Figure 14 illustrate an implantable valve made in two parts in its compressed presentation squeezed on a two-balloon catheter with a reinforced frame on a first balloon and with the implantable valve on the second balloon; and
- Figures 15a to 15f illustrate the successive steps of the implantation of the implantation valve in two parts with a two-balloon catheter;

#### DETAILED DESCRIPTION OF THE PREFERRED EMBODIMENTS

**[0049]** In the diastole and systole illustrations of section views of Figures 1a and 1b, the arrows A indicates the general direction of the blood flow. The semi-lunar leaflets 1 and 2 of a native aortic valve (with only two out of three shown here) are thin, supple and move easily from the completely open position (systole) to the closed position (diastole). The leaflets originate from an aortic annulus 2a.

**[0050]** The leaflets 1' and 2' of a stenosed valve as illustrated in Figure 1c. are thickened, distorted, calcified and more or less fused, leaving only a small hole or a narrow slit 3, which makes the ejection of blood from the left ventricle cavity 4 into the aorta 5 difficult and limited. Figures 1a to 1c show also the coronary artery ostium

6a and 6b and Figure 1a shows, in particular, the mitral valve 7 of the left ventricle cavity 4.

**[0051]** An implantable valve according to the invention essentially comprises a supple valvular structure supported by a strong frame. The positioning of the implantable valve is an important point since the expanded frame has to be positioned exactly at the level of the native valvular leaflets 1, 2 of the native valve, the structures of which are pushed aside by the inflated balloon.

**[0052]** Ideally, the implantable valve is positioned with the fastening line of the valvular structure on the frame exactly on the remains of the crushed stenosed valve to prevent any regurgitation of blood. In practice, it is difficult to position the implantable valve within less than 2 or 3 mm. However, any risk of regurgitation of blood is eliminated with the presence of an internal cover, as will be described below.

**[0053]** The upper limit of the frame should be placed below the opening of the coronary arteries, i.e., the coronary ostia 6, or at their level so that the frame does not impede free blood flow in the coronary arteries. This point is a delicate part of positioning an IV since the distance between the superior limit of the leaflets of the natural valve and the coronary ostia 6 is only about 5 to 6 mm. However, the ostia are located in the Valsalva sinus 8 which constitutes a hollow that are located a little out of the way. This helps to prevent from impeding the coronary blood flow by the IV.

**[0054]** At the time of implantation, the operator evaluates the exact positioning of the coronary ostia by looking at the image produced by a sus-valvular angiogram with contrast injection performed before the implantation procedure. This image will be fixed in the same projection on a satellite TV screen and will permit the evaluation of the level of the origin of the right and left coronary arteries. Possibly, in case the ostia are not clearly seen by sus-valvular angiography, a thin guide wire, as those used in coronary angioplasty, is positioned in each of the coronary arteries to serve as a marker of the coronary ostia.

**[0055]** The lower part of the frame of the IV preferably extends by 2 or 3 mm inside the left ventricle 4, below the aortic annulus 2a. However, this part of the frame should not reach the insertion of the septal leaflet of the mitral valve 7, so that it does not interfere with its movements, particularly during diastole.

**[0056]** Figures 2a and 2b show respectively an example of a cylindrical frame 10 comprising intercrossing linear bars 11, with two intersections I by bar 11, the bars 11 being soldered or provided from a folded wire to constitute the frame, with for instance a 20 mm, 15 mm or 12 mm height, and an example with only one intersection of bars 11. Preferably, such a frame is expandable from a size of about 4 to 5 millimeters to a size of about 20 to 25 mm in diameter, or even to about 30-35 mm (or more) in particular cases, for instance for the mitral valve. Moreover, said frame, in its fully expanded state, has a height of approximately between 10 and 15 mm and in its fully compressed frame, a height of approximately 20 mm.

The number and the size of the bars are adapted to be sufficiently strong and rigid when the frame is fully open in the aortic orifice to resist the strong recoil force exerted by the distorted stenosed aortic orifice after deflation of the balloon used in the catheterization technique which has been previously maximally inflated to enlarge the stenosed valve orifice;

**[0057]** The frame may have several configurations according to the number of bars 11 and intersections. This number, as well as the size and the strength of the bars 11, are calculated taking into account all the requirements described, i.e., a small size in its compressed form, its capacity to be enlarged up to at least 20 mm in diameter and being strong when positioned in the aortic orifice to be able to be forcefully embedded in the remains of the diseased aortic valve and to resist the recoil force of the aortic annulus. The diameter of the bars is chosen, in the range of 0.1-0.6 mm.

**[0058]** A frame particularly advantageous presents, when deployed in its expanded state, an opening out 12 at both extremities as shown in Figures 3a and 3b, the frame having a linear profile (Figure 3a) or a concave shape profile (Figure 3b). This is aimed at reinforcing the embedding of the IV in the aortic orifice. However, the free extremities of the openings 12 are rounded and very smooth to avoid any traumatism of the aorta or of the myocardium.

**[0059]** The structure of a preferred frame used in the present invention both maintains the aortic orifice fully open once dilated and produces a support for the valvular structure. The frame is also foldable. When folded by compression, the diameter of said frame is about 4 to 5 millimeters, in view of its transcatheter introduction in the femoral artery through an arterial sheath of 14 to 16 F (F means French, a unit usually used in cardiology field) i.e., about 4.5 to 5.1 mm. Also, as described below, when positioned in the aortic orifice, the frame is able to expand under the force of an inflated balloon up to a size of 20 to 23 mm in diameter.

**[0060]** The frame is a metallic frame, preferably made of steel. It constitutes a frame with a grate type design able to support the valvular structure and to behave as a strong scaffold for the open stenosed aortic orifice.

**[0061]** When the frame is fully expanded, its intercrossing bars push against the remains of the native stenosed valve that has been crushed aside against the aortic annulus by the inflated balloon. This produces a penetration and embeds the bars within the remains of the stenosed valve, in particular owing to a concave profile of the frame provided with an opening out, as illustrated in Figure 3b. This embedding of the frame on the aortic annulus, or more precisely on the remains of the crushed distorted aortic valve, will be determinant for the strong fixation of the IV in the right position, without any risk of displacement.

**[0062]** Moreover, the fact that the valve leaflets in degenerative aortic stenosis are grossly distorted and calcified, sometimes leaving only a small hole or a small slit

in the middle of the orifice, has to be considered an advantage for the implantation of the valve and for its stable positioning without risk of later mobilization. The fibrous and calcified structure of the distorted valve provides a strong base for the frame of the IV and the powerful recoil phenomenon that results from elasticity of the tissues contribute to the fixation of the metallic frame.

**[0063]** The height of the fully expanded frame of the illustrated frames 10 is preferably between 10 and 15 mm. Indeed, since the passage from the compressed state to the expanded state results in a shortening of the metallic structure, the structure in its compressed form is a little longer, i.e., preferably about 20 mm length. This does not constitute a drawback for its transcatheter introduction and its positioning in the aortic orifice.

**[0064]** As mentioned above, the frame is strong enough to be able to oppose the powerful recoil force of the distended valve and of the aortic annulus 2a. Preferably it does not possess any flexible properties. When the frame has reached its maximal expanded shape under the push of a forcefully inflated balloon, it remains substantially without any decrease in size and without any change of shape. The size of the bars that are the basic elements of the frame is calculated in such a way to provide a substantial rigidity when the frame is fully expanded. The size of the bars and their number are calculated to give both maximal rigidity when expanded and the smallest volume when the metallic frame is its compressed position.

**[0065]** At the time of making the IV, the frame is expanded by dilatation to its broadest dimension, i.e., between 20 mm and 25 mm in diameter, so as to be able to fasten the valvular structure on the inside side of its surface. This fastening is performed using the techniques in current use for the making of products such as other prosthetic heart valves or multipolar catheters etc. Afterwards, it is compressed in its minimal size, i.e., 4 or 5 mm, in diameter in view of its introduction in the femoral artery. At time of the IV positioning, the frame is expanded again by balloon inflation to its maximal size in the aortic orifice.

**[0066]** If the frame is built in an expanded position, it will be compressed, after fastening the valvular structure, by exerting a circular force on its periphery and/or on its total height until obtaining the smallest compressed position. If the frame is built in its compressed position, it will be first - dilated, for instance, by inflation of a balloon and then compressed again as described above.

**[0067]** To help localizing the IV, the frame being the only visible component of the valve, the shaft of the balloon catheter on which will be mounted the IV before introduction in the body (see below) possesses preferentially metallic reference marks easily seen on fluoroscopy. One mark will be at level of the upper border of the frame and the other at the level of the lower border. The IV, when mounted on the catheter shaft and crimped on it, is exactly positioned taking into account these reference marks on the shaft.

**[0068]** Accordingly, the frame is visible during fluoroscopy when introduced in the patient's body. When the frame is positioned at the level of the aortic annulus, the upper border of the frame is placed below the coronary ostia. Furthermore, the implanting process during which the balloon inflation completely obstructs the aortic orifice, as seen below, is performed within a very short time, i.e., around 10 to 15 seconds. This also explains why the frame is clearly and easily seen, without spending time to localize it. More particularly, its upper and lower borders are clearly delineated.

**[0069]** Figures 4a and 4b show an example of an IV 13, respectively in its compressed position, in view of its introduction and positioning in the aortic orifice, and in its expanded and opened (systole) position. Figures 5a and 5b show the expanded position of this example closed in diastole, respectively in perspective and in a crossed section view along the central axis X'X of the valve prosthesis.

**[0070]** The valvular structure 14 is compressed inside the frame 10 when this is in its compressed position (Figure 4a), i.e., it fits into a 4 to 5 mm diameter space. On the other hand, the valvular structure can expand (Figure 4b) and follow the frame expansion produced by the inflated balloon. It will have to be able to reach the size of the inside of the fully deployed frame.

**[0071]** The illustrated IV 13 is made of a combination of two main parts:

- 1) the expandable but substantially rigid structure made of the frame 10, a metallic frame in the example; and
- 2) a soft and mobile tissue constituting the valvular structure 14 exhibiting a continuous surface truncated between a base 15 and an upper extremity 16; the tissue is fastened to the bars 11 of the frame at its base 15 and is able to open in systole and to close in diastole at its extremity 16, as the blood flows in a pulsatile way from the left ventricle towards the aorta.

**[0072]** The tissue has rectilinear struts 17 incorporated in it in plane including the central axis X'X, in order to strengthen it, in particular, in its closed state with a minimal occupation of the space, and to induce a patterned movement between its open and closed state. Other examples of strengthening struts are described below. They are formed from thicker zones of the tissue or from strips of stiffening material incorporated in the tissue; they can also be glued or soldered on the valvular tissue.

**[0073]** These strengthening struts help to prevent the valvular tissue from collapsing back too much and to evert inside the left ventricle through the base of the frame. These reinforcements of the valvular tissue help maintain the folded tissue above the level of the orifice during diastole, prevent too much folding back and risk of inversion of the valvular structure inside the left ventricle. By also preventing too much folding, a decrease of the risk

of thrombi formation can also be expected by reducing the number of folds.

**[0074]** The truncated shape forming a continuous surface enables to obtain a strong structure and is more efficient for the systolo-diastolic movements of the valvular tissue during heart beats. The truncoidal shape facilitates the closure of the valve structure at the beginning of diastole in facilitating the start of the reverse movement of the valvular tissue towards its base at the time of diastole, i.e., at the time of flow reversal at the very beginning of diastole. During diastole, the valvular structure 14 thus falls down, folding on itself, thereby collapsing on its base, and therefore closing the aortic orifice. In fact, the valvular structure has preferably, as illustrated, an hyperboloid shape, with a curvature on its surface concave towards the aortic wall that will contribute to initiating its closure.

**[0075]** Moreover, the basis of the truncated hyperboloid is fixed on the lower part of a frame and the smallest extremity of the truncated hyperboloid is free in the blood stream, during the respected closing and opening phasis.

**[0076]** An important advantage of this hyperboloidal shape is that the upper extremity 16 of the valvular structure 14 can remain at a distance from the coronary ostia during systole as well as during diastole, because of its smaller diameter, thus offering an additional security to make certain that the passage of blood from aorta to the coronary ostia is not impeded.

**[0077]** The base 15 of the truncated tissue is attached on the frame 10 along a line of coupling 18 disposed between the inferior fourth and the third fourth of the frame in the example. The upper extremity 16, with the smaller diameter, overpasses the upper part of the frame by a few millimeters; 6 to 8 mm, for instance. This gives the valvular structure a total height of about 12 to 15 mm.

**[0078]** The upper extremity 16 of the truncated tissue, i.e., the smaller diameter of the hyperboloidal structure 14, is about 17 to 18 mm in diameter (producing a 2.3 to 2.5 cm<sup>2</sup> area opening) for a 20 mm diameter base of the truncated structure, or 19 to 20 mm in diameter (producing a 2.8 or a 3 cm<sup>2</sup> area opening) for a 23 mm diameter base. An opening area around 2 cm<sup>2</sup> or slightly above, gives satisfactory results, particularly in elderly patients who would not reasonably need to exert high cardiac output.

**[0079]** For instance, in the present example, the line of fastening of the base of the truncated tissue on the frame will have to expand from a 12.5 mm perimeter (for a 4 mm external diameter of the compressed IV) to a 63 mm perimeter (for a 20 mm external diameter of the expanded IV), or to a 72 mm perimeter (for a 23 mm external diameter, in case a 23 mm balloon is used).

**[0080]** Another advantage of this truncated continuous shape is that it is stronger and has less risk of being destroyed or distorted by the forceful balloon inflation at the time of IV deployment. Also, if the truncated hyperboloidal shape is marked, for instance, with a 16 or 17 mm diameter of the upper extremity as compared to a

20 mm diameter of the base (or 18 to 20 mm for 23 mm), the smaller upper part is compliant during balloon inflation in order to enable the balloon to expand cylindrically to its maximal 20 mm diameter (or 23 mm). This is made possible by using a material with some elastic or compliant properties.

**[0081]** The valvular structure of the invention, as shown in the illustrated example, includes advantageously a third part, i.e., the internal cover 19 to be fixed on the internal wall of the frame 10. This internal cover prevents any passage of blood through the spaces between the bars 11 of the frame in case the implantable valve would be positioned with the fastening line of the valvular structure on the frame not exactly on the remains of the dilated aortic valve, i.e., either above or below. It also strengthens the fastening of the valvular structure 14 to the frame 10.

**[0082]** In the different sectional views of the different examples of IV as illustrated at Figures 6a to 6c, the internal cover 19 covers the totality of the internal side of the frame 10 (Figure 6a), only the lower part of the frame 10 according to the invention (figure 6b), or it can additionally cover partially 3 to 5 mm as shown in the passage of blood from aorta to the coronary ostia Figure 6c, the upper part defined above the coupling line 18 of the valvular structure.

**[0083]** For instance, such an extension of the internal cover 19 above the fastening line 18 of the valvular structure will give another security to avoid any risk of regurgitation through the spaces between the bars 11 in case the IV would be positioned too low with respect to the border of the native aortic valve.

**[0084]** The internal cover can also be molded to the valvular structure or casted to it which therefore constitutes an integral structure. The valvular structure and the internal cover are therefore strongly locked together with minimum risk of detachment of the valvular structure which is unceasingly in motion during systole and diastole. In that case, only the internal cover has to be fastened on the internal surface of the frame which renders the making of the IV easier and makes the complete device stronger and more resistant. In particular, the junction of the mobile part of the valvular structure and the fixed part being molded as one piece is stronger and capable to face the increasing movements during the systolo-diastolic displacements without any risk of detachment.

**[0085]** The presence of the internal cover makes an additional layer of plastic material that occupies the inside of the frame and increases the final size of the IV. Therefore, in the case in which the internal cover is limited to the inferior part of the frame (that is, below the fastening line of the valvular structure), it does not occupy any additional space inside the frame. Here also, it is more convenient and safer to make the valvular structure and this limited internal cover in one piece.

**[0086]** In other aspects, to prevent any regurgitation of blood from the aorta towards the left ventricle during di-

astole, the base of the valvular structure is preferably positioned exactly at the level of the aortic annulus against the remains of distorted stenosed valve pushed apart by the inflated balloon. Therefore, there is no possibility of blood passage through the spaces between the metallic frame bars 11 below the attachment of the valvular structure.

**[0087]** However, to avoid any risk of leaks, the part of the frame below the fastening of the valvular structure (about 3 to 5 mm) is covered by an internal cover which is made with the same tissue as the valvular structure. Thus, there would be no regurgitation of blood which is a possibility when there is any space between the valvular structure fastened on the metallic frame and the line of application of the frame on the aortic annulus. The internal cover makes a sort of "sleeve" below the fastening of the valvular structure on the internal surface of the frame, covering the spaces between the frame bars of the frame at this level, thus preventing any regurgitation of blood through these spaces.

**[0088]** The internal cover can also have another function, i.e., it can be used to fasten the valvular structure inside the frame, as described below.

**[0089]** At Figure 6d, the internal cover 19 is extended at its lower end 19' to an external cover 19" which is rolled up to be applied on the external wall of the stent 10. The internal and external cover are molded, glued or soldered to the bars of the stent 10.

**[0090]** The coupling process of the valvular structure on the frame is of importance since it has to be very strong without any risk of detachment of the valvular structure from the frame during millions of heart beats with pulsatile blood flow alternatively opening and closing the valvular structure.

**[0091]** The valvular structure of the invention folds to a very small size inside the frame in the compressed position of the valve and is expandable up to 20 to 23 mm diameter. Also, the valvular structure can resist the strong force exerted by the maximally inflated balloon that will powerfully squeeze it against the bars of the frame or against the internal cover, this one being squeezed directly against the bars of the frame. The junction zone is also particularly subjected to very strong pressure exerted by the inflated balloon. Furthermore, this junction zone must not tear or break off during expansion of the balloon. At this time, each part of the junction zone is squeezed against the bars but nonetheless follows the expansion of the frame.

**[0092]** As shown in Figure 7, the junction zone is, for example, a fastening line 20 which follows the design of a "zig-zag" line drawn by the intercrossing bars 11 of the frame on the internal cover 19.

**[0093]** The fastening of the valvular structure to the frame is made by sewing the internal and/or the external cover to the bars. To prevent any leakage of blood, stitches are preferably numerous and very close to each other, either as separated stitches or as a continuous suture line. Also, the stitches are made directly around the bars

11. Furthermore, since the valvular structure is expanded together with the metallic frame, the stitches, if made as a continuous suture line, are also able to expand at the same time.

**[0094]** According to an example, the fastening process can also be made by molding the base of the valvular structure on the frame. At this level, the bars 11 are imbedded in the coupling line of the valvular structure 14. This mold way also concerns the internal cover 19, when it goes below the coupling line 14 on the frame over few millimeters, for example, 2 to 4 mm. As mentioned above, this is intended in order to prevent any regurgitation of blood just below the lower part of the valvular structure 14 in case the frame 10 would not be exactly positioned on the aortic annulus but at few millimeters away.

**[0095]** The fastening process as examples can further be made by gluing or soldering the valvular structure on the bars with sufficiently powerful biocompatible glues. The same remark can be made concerning the internal cover of the frame below the coupling line of the valvular structure.

**[0096]** Also, this allows the coupling line to follow the frame changes from the compressed position to its expanded one.

**[0097]** The valvular structure can also be fastened on the internal cover previously fixed at the total length of the internal surface of the metallic frame. The internal cover constitutes therefore a surface on which any type of valvular structure be more easily sewed, molded or glued. Because it is a structure with a large surface and is not involved in the movements of the valvular tissue during systole and diastole, the internal cover is more easily fastened to the internal surface of the frame.

**[0098]** In the particular example shown in Figure 8, the internal cover 19 is fastened, after introduction (indicated by the arrow B), at the upper and lower extremities of the frame 10 on the upper and lower zig-zag lines of the intercrossing bars 11. In fact, the fastening of the internal cover 19 on the zig-zag lines made by the intercrossing bars 11 of the frame allows an easier passage of blood from the aorta above the IV towards the coronary ostia. Indeed, the blood can find more space to flow into the coronary ostia by passing through the lowest point of each triangular space made by two intercrossing bars 11, as indicated by the arrows A1 (see also Figure 1b).

**[0099]** The fastening of the internal cover 19 on the extremities can be reinforced by various points of attachment on various parts of the internal surface of the frame 10. The internal cover 27 is fastened by sewing, the bars 11 onto the frame.

**[0100]** Fastening the valvular tissue (and the cover tissue below) on the inside of the frame, requires work on the frame in its expanded position to have access to the inside of this cylindrical frame. In a preferred example the frame is expanded a first time for fastening the valvular tissue on its bars, then compressed back to a smaller size to be able to be introduced via arterial introducer and finally expanded again by the balloon inflation.

**[0101]** Since it is aimed at being positioned in the heart after having been introduced by a catheterization technique by a transcutaneous route in a peripheral artery, mainly the femoral artery, the IV should preferably have the smallest possible external diameter. Ideally, it should be able to be introduced in the femoral artery through a 14 F (4,5 mm) size arterial introducer which is the size of the arterial introducer commonly used to perform an aortic dilatation. However, a 16 F (5,1 mm) or even a 18 F (5,7 mm) introducer would also be acceptable.

**[0102]** Above this size, the introduction of the IV in the femoral artery should probably be done by a surgical technique. This is still quite acceptable since the surgical procedure would be a very light procedure which could be done by a surgeon with a simple local anaesthesia. It has to be recalled that this technique is used to position big metallic frames, about 24 F in size (7.64 mm in diameter), in the abdominal aorta for the treatment of aneurysms of the abdominal aorta. In that situation, this necessitates surgical repair of the artery after withdrawal of the sheath (M. D. Dake, New Engl. J Med. 1994;331: 1729-34).

**[0103]** Ideally, an IV should be able to last several tenths of life years without defect, like the mechanical prosthetic valves which are currently implanted by the surgeons. Nevertheless, an implantable valve that would last at least ten years without risk of deterioration would be effective for the treatment of elderly patients.

**[0104]** A valvular structure according to the invention is made of a supple and reinforced tissue which has a thickness to be thin enough to occupy as less as possible space in the compressed form of the valve, is pliable, and also strong enough to stand the unceasing movements under the blood pressure changes during heart beats. The valvular structure is capable of moving from its closed position to its open position under the action of the force exerted by the movements of the blood during systole and diastole, without having any significant resistance to blood displacements.

**[0105]** The material used for the tissue, which exhibits the above mentioned requirements, may be Teflon® or Dacron®, which are quite resistant to folding movements, at least when they are used to repair cardiac defects such as inter-atrial or interventricular defects or when they are used to repair a valve such as the mitral valve which is subjected to high pressure changes and movements during heart beats. Also, a main point is the increasing systolo-diastolic movements of the valvular tissue, particularly at its junction with the rigid part of the IV, and it is therefore necessary to find the most possible resistant material tissue.

**[0106]** As mentioned previously, the valvular structure is made according to the invention with biological tissue, namely pericardium, which is commonly used in bioprosthetic surgically implanted valves.

**[0107]** Moreover, the valvular prosthesis of the present invention does not induce any significant thrombosis phenomenon during its stay in the blood flow and is biolog-

ically neutral.

**[0108]** To prevent the risk of thrombus formation and of emboli caused by clots, a substance with anti-thrombic properties could be used, such as heparine, ticlopidine, phosphorylcholine, etc. either as a coating material or it can be incorporated into the material used for the implantable valve, in particular, for the valvular structure and/or for the internal cover.

**[0109]** The valvular structure can have several types of designs and shapes. Besides the example illustrated in Figures 4 and 5, examples of strengthened valvular structures according to the invention are shown in Figures 9 to 11, respectively in the closed (figures 9a, 10a, 11a) and in the open state (figures 9b, 10b, 11b) to form a prosthetic valve

In those figures, the frame line is simplified to clarify the drawings.

**[0111]** To help initiate and finalize the closure of the valvular structure, four strengthening struts 14 are slightly inclined from the base to the upper part as compared to the central axis X'X of the structure, as shown in Figures 9a and 9b. Accordingly, a patterned movement of the valvular structure, during the closing and the opening phases, is initiated. This patterned movement is, in the present case, an helicoïdal-type one, as suggested in Figures 9b and 10b by the circular arrow.

**[0112]** Figures 10a and 10b illustrate another example to help the closing of the valvular structure and which also involves an helicoïdal movement. Represented by lines 22, inclined pleats are formed in the tissue to impart such a movement. As illustrated, these lines have an inclination from the base to the upper part of the tissue 14. Pleats are formed by folding the tissue or by alternating thinner and thicker portions. The width and the number of those pleats are variable, and depend particularly on the type of material used. According to another example, these pleats 34 are combined with the above described inclined strengthening struts.

**[0113]** These reinforcing pleats and/or struts, rectilinear or inclined, have the advantage to impart a reproducible movement and, accordingly, to avoid the valvular structure from closing to a nonstructurized collapse on the frame base.

**[0114]** Another shape of the valvular structure comprises two portions: one portion being flexible but with some rigidity, having a rectangular shape, occupying about one third of the circumference of the valvular structure, and the other portion being more supple, flexible and foldable occupying the rest of the circumference at its base as well as at its upper, free border. According to Figure 11c, this valve is opened, during the ejection of blood, i.e., during systol. In Figure 11d, a front view of the valve is closed, during an intermediate diastole, and in Figure 11e the same closed valve during diastole is shown from a side view. The semi-rigid part 24' moves little during systole and during diastole. The foldable part 23' moves away from the rigid part during systole to let the blood flow through the orifice thus made. This orifice,



due to the diameter of the upper part which is the same as that of the open stent, is large, generally as large as that of the open stent. At the time of diastole, due to the reverse of pressure, the foldable part moves back towards the semi-rigid part and presses on it, and thus closes the orifice and prevents any regurgitation of blood.

**[0115]** The advantage of such a valve design is to allow a large opening of the upper part of the valvular structure, not only to permit more blood flow at time of systole after the valve has been implanted, but also at the very time of implantation, when the balloon is maximally inflated to expand the valve to imbed it in the valvular annulus. The diameter of the upper part of the valvular structure could be the same size as the balloon, so that there would be no distension of the valvular part of the valve at the time of implantation, and therefore no risk of deterioration of the valvular structure by the inflated balloon.

**[0116]** The foldable part of the valve could be reinforced by strengthening struts to prevent an eversion of the valve towards the left ventricle during diastole.

**[0117]** Another shape of the valvular structure, as illustrated in Figures 11 a and 11 b comprise four portions, alternatively a main portion 23 and a more narrow portion 24. The main and the narrow portions are facing each other. Each portion has an isosceles trapezoidal shape. The main portions 23 are flexible but with some slight rigidity and the more narrow portions 24 are compliant, more supple and foldable. In this type of design, the two slightly rigid portions 23 maintain the valvular structure closed during diastole by firmly applying on each other in their upper extremities, thus forming a slot-like closure 25. This particular example needs less foldable tissue than in the previous examples and the closure of the valvular structure at the time of early diastole does not have any tendency to collapse towards the aortic annulus.

**[0118]** Another design for the valvular structure is a combination of a cylindrical shape followed by a truncated shape.

**[0119]** This type of valvular structure is longer than the hyperboloidal type, for instance, 25 or 30 mm long, therefore exceeding out of the upper part of the metallic frame, by 10 to 20 mm. The cylindrical part corresponds to the metallic frame and remains inside it. The truncated conic shape is the upper part of the valvular structure, totally exceeding out of the upper extremity of the metallic frame. An advantage of such a design is that the balloon can be inflated only in the cylindrical part of the valvular structure, therefore without risk of stretching the truncated conical part of the upper diameter which is smaller than that of the inflated balloon.

**[0120]** When the upper extremity of the cylindrical part has the same size as the lower extremity, there is no difference during balloon inflation in the degree of force exerted by the balloon on the lower and on the upper extremity of the valvular structure. Preferably, rectilinear reinforcing struts are used in this embodiment, to strengthen the valve structure and aid in its shutting without collapsing and inverting inside the left ventricle

through the aortic annulus under the force of the diastolic pressure.

**[0121]** Two different processes for implanting a valve according to the present invention are shown respectively in Figures 13a to 13l with a unique balloon catheter, as illustrated in Figures 12a and 12b and in Figures 15a to 15f, with a two-balloon catheter, as illustrated in Figure 14.

**[0122]** The IV positioning in the aortic orifice and its expansion can be performed with the help of a unique substantially cylindrical balloon catheter 26 in the so-called unique-balloon catheterization technique.

**[0123]** Preparing for its introduction by transcatheter route in the femoral artery, the IV 13 is, as illustrated in the perspective view of Figure 10a in a compressed form crimped on the balloon catheter 26. A central sectional view of the mounted IV 13 on the complete balloon catheter 26 is shown in Figure 12b.

**[0124]** The shaft 27f of the balloon dilatation catheter 26 is as small as possible, i.e., a 7F (2.2 mm) or a 6 F (1.9 mm) size. The balloon 26 is mounted on the shaft 27 between two rings R. Moreover, the shaft 27 comprises a lumen 28 (Figure 12b) as large as possible for inflation of the balloon 26 with diluted contrast to allow simple and fast inflation and deflation. It has also another lumen 29 able to accept a stiff guide wire 30, for example 0.036 to 0.038 inches (0.97 mm), to help position the implantable valve with precision.

**[0125]** The balloon 26 has, for example, a 3 to 4 cm length in its cylindrical part and the smallest possible size when completely deflated so that it will be able to be placed inside the folded valve having an outside diameter which ranges between about 4 and 5 mm. Therefore, the folded balloon preferably has at the most a section diameter of about 2.5 to 3 mm.

**[0126]** The balloon is therefore made of a very thin plastic material. It is inflated with saline containing a small amount of contrast dye in such a way to remain very fluid and visible when using X-ray.

**[0127]** However, the balloon 26 has to be sufficiently strong to resist the high pressure that it has to withstand to be capable of expanding the folded valvular structure 14 and the compressed frame in the stenosed aortic orifice considering that, although pre-dilated, the aortic orifice still exerts a quite strong resistance to expansion because of the recoil phenomenon.

**[0128]** This procedure is shown in Figures 13a to 13e.

**[0129]** In contrast to the technique used when performing the usual aortic dilatation (without valve implantation), i.e., inflating the balloon maximally markedly above the nominal pressure, if possible, up to the bursting point (which occurs always with a longitudinal tear, without deleterious consequence, and with the advantage of both exerting a maximal dilating force and restoring blood ejection instantaneously), the balloon inflated for expansion of an implantable valve should not burst in any case. Indeed, bursting of the balloon would involve a risk of incomplete valve expansion and wrong positioning.

Therefore, the balloon should be very resistant to a very high pressure inflation. Furthermore, the balloon is inflated only up to the nominal pressure indicated by the maker and the pressure is controlled during inflation by using a manometer. Such relatively low pressure should be sufficient since prior to positioning the IV, an efficacious dilatation of the stenosed aortic valve according to the usual technique with a maximally inflated balloon for example 20 mm or 25 mm in size in such a way to soften the distorted valvular tissue and facilitate the enlargement of the opening of the valve at time of IV implantation is performed.

**[0130]** The implantation of the aortic valve 20 can be made in two steps, as described as follows.

**[0131]** The first step, as shown in Figures 13a to 13f, consists in introducing the shaft 27 and balloon catheter 26 along the guide wire previously positioned in the ventricle 4 (Figures 13a-13b). The dilatation of the stenosed aortic valve 1', 2' using a regular balloon catheter, according to the commonly performed procedure, i.e., with the guide wire 30 introduced in the ventricle 4 (Figure 13a) and with maximal inflation of the balloon 26 (Figures 13c to 13d) up to the bursting point. Dilatation is performed at least with a balloon having about 20 mm diameter, but it can be performed with a balloon having about 23 mm diameter so as to increase maximally the aortic orifice opening before implantation of the valve although the implantable valve is about 20 mm in diameter. This preliminary dilatation of the aortic orifice helps in limiting the force required to inflate the balloon used to expand the implantable valve and position it in the aortic orifice, and also in limiting the recoil of the aortic valve that occurs immediately after balloon deflation. The balloon is deflated (Figure 13a) and pulled back on the wire guide 30 left inside the ventricle.

**[0132]** Owing to the marked recoil of the stenosed valve and also of the strong aortic annulus, the 20 mm diameter valve is forcefully maintained against the valvular remains at the level of the aortic annulus. Preliminary dilatation has another advantage in that it permits an easier expansion of the IV, having a lower pressure balloon inflation which helps prevent damage of the valvular structure of the IV. This also facilitates the accurate positioning of the prosthetic valve.

**[0133]** The second step corresponds to the implantation of the valve 13 is shown in Figures 13g to 13l. The positioning of the IV needs to be precise at a near 2 or 3 mm, since the coronary ostia 6 has to remain absolutely free of any obstruction by the valve 13 (Figures 13k and 13l). As mentioned above, this is, for example, performed with the help of the image of the sus-valvular angiogram in the same projection fixed on an adjacent TV screen. The expansion and the positioning of the valve prosthesis 13 is performed within a few seconds (15 to 20 among at most) since during the maximal balloon inflation (which has to be maintained only a very few seconds, 3, 4, 5) the aortic orifice is obstructed by the inflated balloon 31 and the cardiac output is zero (Figure 13h). As for the

pre-dilatation act itself, the balloon 26 is immediately deflated within less than 5 or 6 seconds (Figure 13j) and, as soon as the deflation has clearly begun, the closing and opening states of the IV are active whereas the balloon is pulled back briskly in the aorta (Figures 13j to 13l). In case the IV is not maximally expanded by the first inflation, it is possible to replace the balloon inside the IV and to reinflate it so as to reinforce the expansion of the IV.

**[0134]** The IV 13 can also be used in aortic regurgitation. This concerns more often younger patients rather than those with aortic stenosis. The contraindication to surgical valve replacement is often not due to the old age of the patients, but stems mainly from particular cases where the general status of the patient is too weak to allow surgery, or because of associated pathological conditions. Apart from the fact that there is no need for a preliminary dilatation, the procedure of the valve implantation remains approximately the same. The balloon inflation inside the IV is chosen accordingly, taking also into account the fact that it is necessary to overdilate the aortic annulus to obtain a recoil phenomenon of the annulus after balloon deflation to help maintain the IV in position without any risk of displacement.

**[0135]** However, the size of the expanded implantable valve is around 25 to 30 mm in diameter, or even bigger, because the aortic annulus is usually enlarged. A preliminary measurement of the annulus will have to be performed on the sus-valvular angiography and by echocardiography to determine the optimal size to choose.

**[0136]** The IV can be used in the mitral position, mainly in case of mitral regurgitation, but also in case of mitral stenosis. Here again, the IV 20 is only described when used only in cases of contraindication to surgical valve repair or replacement. The procedure is based on the same general principles though the route for the valve positioning is different, using the transeptal route, like the commonly performed mitral dilatation procedure in mitral stenosis. The IV size is quite larger than for the aortic localization (about 30 to 35 mm in diameter when expanded or clearly above in case of a large mitral annulus, a frequent occurrence in mitral insufficiency), to be capable of occupying the mitral area. A preliminary measurement of the mitral annulus is performed to determine the optimal implantable valve size to choose. Since the introduction of the IV is performed through a venous route, almost always through the femoral vein which is quite large and distensible, the bigger the size of the IV in its compressed position is not a drawback even if the diameter size is about 6 or 7 mm. Moreover, the problem of protection of the coronary ostia as encountered in the aortic position does not exist here which therefore makes the procedure easier to be performed.

**[0137]** Finally, the IV can be used to replace the tricuspid valve in patients with a tricuspid insufficiency. This procedure is simple to perform since the positioning of the IV is made by the venous route, using the shortest way to place in the right position at the level of the tricus-

pid orifice practically without any danger from clot migration during the procedure. A large implantable valve is used, with a diameter of about 40 mm or even larger because the tricuspid annulus is often markedly dilated in tricuspid insufficiency. Here also, as in the mitral position, the compressed IV and the catheter used can be without inconvenience, quite larger than that for the aortic position because of the venous route used.

**[0138]** Furthermore, it has to be noted that the IV can be used also as a first step in the treatment of patients who have contraindication to surgery, when they are examined for the first time, but who could improve later on after correction of the initial hemodynamic failure. The IV procedure can be used as a bridge towards surgery for patients in a weak general condition which are expected to improve within the following weeks or months after the IV procedure in such a way that they can be treated by open heart surgery later on. In the same vein, the IV procedure can be used as a bridge towards surgical valve replacement or repair in patients with a profoundly altered cardiac function that can improve secondarily owing to the hemodynamic improvement resulting from the correction of the initial valvular disease by the IV implantation.

**[0139]** Another technique for implantation of an aortic valve by transcatheterization uses a two-balloon catheter.

**[0140]** An example of this technique using the two parts IV with a two-balloon catheter 40 is shown in Figure 14.

**[0141]** Two-balloons 26 and 26' are fixed on a unique catheter shaft 27, said balloons being separated by a few millimeters. The two balloons are preferably short, i.e., about 2 to 2.5 cm long in their cylindrical part. The first balloon 26 to be used, carries a first frame 10 aimed at scaffolding the stenosed aortic orifice after initial dilatation. This first balloon 26 is positioned on the aorta side, above the second balloon 26' which is positioned on the left ventricle side. The second balloon 26' carries the expandable valve 13 which is of the type described above made of a second frame 10' and a valvular structure 14 attached to said frame 10'. The difference is that the second frame does not need to be as strong as the first frame and is easier to expand with low balloon pressure inflation which does not risk damaging the valvular structure 14.

**[0142]** This enlarges the choice for making a valvular structure without having to face two contradictory conditions:

- 1) having a soft and mobile valvular structure 14 capable of opening and closing freely in the blood stream without risk of being damaged by a balloon inflation; and
- 2) needing a reinforced frame strong enough to be capable of resisting without any damage, a strong pressure inflation of the expanding balloon.

**[0143]** The shaft 27 of this successive two-balloon catheter 40 comprises two lumens for successive and

separate inflation of each balloon. Indeed, an additional lumen capable of allowing a fast inflation occupies space in the shaft and therefore an enlargement of the shaft is necessary. However, this enlargement of the shaft stops at the level of the first balloon 26 since, further to said first balloon, only one lumen is necessary to inflate the second balloon 26', at the level of the IV which is the biggest part of the device.

**[0144]** Another advantage of this two part IV with a two-balloon catheter is that each set of implantable valve and balloon has a smaller external diameter since each element to be expanded, considered separately, is smaller than in combination. This allows obtaining more easily a final device with an external diameter 14 F.

**[0145]** The first balloon is sufficiently strong to avoid bursting even at a very high pressure inflation. This first balloon is mounted in the frame in its deflated position, prior to its introduction by the strong frame which is aimed to scaffold the dilated stenosed aortic valve. The size and shape of said frame is comparable to what has been described previously but said frame is calculated (in particular the material, the number and diameter of its bars are chosen by the person skilled in the art) to make sure that it will resist the recoil of the dilated valve and that it will be securely embedded in the remains of the native aortic valve.

**[0146]** The second balloon does not need to be as strong as the first one and, therefore, can be thinner, occupying less space and being easier to expand with a lower pressure for balloon inflation. This second balloon 26' is mounted in the valve itself which, as in the preceding description, comprises a frame to support the valvular structure and said valvular structure.

**[0147]** Also, the second frame 10' does not need to be as strong as the first one. This frame can be slightly shorter, 10 mm instead of 12 mm, and its bars can be thinner. This frame can have an external surface which is a bit rough to allow better fixation on the first frame when expanded. The bars may also have some hooks to fasten to the first frame.

**[0148]** The valvular structure is attached on said second frame and expanded by relatively low pressure in the second balloon called hereafter the IV balloon. It does not need to be as strong as in the preceding case (IV in one part and unique balloon catheter technique) and, therefore, it occupies less space and has less risk to be damaged at the time of expansion.

**[0149]** This technique is shown in Figures 15a to 15f.

**[0150]** One of the problems relevant to the IV implantation procedure as described above, with the IV in one part, is the expansion at the same time by the same balloon inflation of both the frame and the valvular structure. Indeed, the frame is a solid element and the valvular structure is a relative weak one that could be damaged when squeezed by the inflated balloon.

**[0151]** Therefore, the valve implantation can be performed in two immediately successive steps. The first step (Figures 15a-15b) corresponds to the expansion

and the positioning of the first frame with the first balloon 26 wherein inflation is performed at a high pressure. The second step (Figures 15d-15e) corresponds to the expansion and the positioning of the valvular structure 14 inside the frame 10' using the second balloon 26'. This second step follows the first one within a few seconds because, in the time interval between the two steps, there is a total aortic regurgitation towards the left ventricle which is an hemodynamic condition that cannot be maintained for more than a few heart beats, i.e., a few seconds, without inducing a massive pulmonary edema and a drop to zero of the cardiac output.

**[0152]** In another example, the first frame to be introduced comprises the valvular structure and the second frame being stronger than the first one to scaffold the previously deleted stenosed aortic valve.

**[0153]** The advantage of this two step procedure would be to allow expansion and positioning of the frame part 10' of the IV 13 using strong pressure inflation of the balloon 26' without the risk of damaging the valvular structure 14 which, for its own expansion, would need only light pressure inflation.

**[0154]** The method is schematically detailed in Figures 15a to 15f. A previous dilatation of the stenosed aortic valve is performed as an initial step of the procedure to prepare the distorted valve to facilitate the following steps:

1/ positioning the double balloon catheter 40 with the first balloon 26 with the frame at the level of the aortic annulus 2a, the second IV balloon 26' being inside the left ventricle beyond the aortic annulus 2a (Figure 15a);

2/ compression of the stenosed aortic valve 1', 2' with the first balloon 26 having a 20 mm, preferably with a 23 mm diameter, the balloon being inflated maximally up to the bursting point, to prepare the IV insertion (Figure 15b). Inflation lasts a few seconds (preferably 10 seconds at most) with powerful pressure being used to expand the frame and forcefully embed said frame in the remains of the dilated valve; 3/ an immediate speedy deflation of said first balloon 26 follows (Figure 15c); as soon as the balloon 26 is beginning to clearly deflate, the first frame 10 remaining attached to the stenosed valve 1', 2', the catheter 40 is withdrawn to position the IV balloon 26' inside the previously expanded frame 26 (Figure 15c in which the frame 10' is partially drawn for clarity purpose);

; 4/ immediately after being well positioned, the IV balloon 26' is promptly inflated, to expand the IV 13 (Figure 15c); and

5/ when the IV 13 is blocked inside the first frame 10, the IV balloon 26' is deflated (Figure 18f).

**[0155]** Finally, the whole device has to be withdrawn to allow hemostasis of the femoral artery puncture hole.

**[0156]** The total duration of the successive steps, par-

ticularly the time during which the balloons are inflated, and the time during which the frame is expanded whereas the valve has not yet been positioned and expanded, is about 20 to 30 seconds. This is feasible if the balloons are inflated and deflated within very a few seconds, 6 to 8, for instance. This is permitted if the lumen of the shaft can be sufficiently large, taking into account the inescapable small diameter size of the shaft. This can also be facilitated by a device producing instantaneously a strong inflation or deflation pressure.

#### Claims

1. A prosthetic valve assembly for replacing a stenotic native aortic valve, comprising:

a metallic frame (10) formed with a plurality of bars having diameters in the range of 0.1 to 0.6 mm, said frame being suitable for implantation within said stenotic native aortic valve and for resisting a recoil force of a native aortic annulus, said frame having upper and lower extremities, said frame being collapsible to a compressed external diameter of 4.5 mm to 5.7 mm for advancement through an arterial introducer into a patient's femoral artery using a catheterization technique, said frame being expandable to an expanded position for implantation within said stenotic native aortic valve, said lower extremity of said frame forming a zig-zag line;

a collapsible valvular structure (14) sutured to said frame between said upper and lower extremities, said valvular structure formed of pericardium, said valvular structure having a closed position for occluding blood flow in one direction; and

an internal cover (19) made with the same tissue as said valvular structure, said internal cover covering only a lower part of said frame, said internal cover having an upper end sutured to said valvular structure and a lower end sutured to said lower extremity of said frame along said zig-zag line, said internal cover sutured to a wall of said frame and extending along an internal surface of said wall of said frame only between said valvular structure and said lower extremity of said frame for covering spaces between said bars of said frame on said lower part of said frame and preventing regurgitation of blood through said wall of said frame below said valvular structure and wherein said wall of said frame is uncovered along an upper part of said frame for permitting passage of blood from the aorta to the coronary ostia.

2. The prosthetic valve assembly of claim 1, wherein said frame (10) has a compressed external diameter

suitable for introduction through an 18F arterial introducer.

3. The prosthetic valve assembly of claim 1, wherein said frame (10) has a compressed external diameter suitable for introduction through an 16F arterial introducer. 5
4. The prosthetic valve assembly of claim 1, wherein said frame (10) has a compressed external diameter suitable for introduction through an 14F arterial introducer. 10
5. The prosthetic valve assembly of any of claims 1 to 4, wherein said expanded position of said frame (10) has an external diameter of about 20 to 25 mm. 15
6. The prosthetic valve assembly of any one of the preceding claims, wherein said frame (10) is made with intercrossing bars. 20
7. The prosthetic valve assembly of any one of the preceding claims, wherein said internal cover (19) is integral with said valvular structure (14) 25
8. The prosthetic valve assembly of any one of the preceding claims, wherein said frame (10) has a generally concave profile. 25
9. The prosthetic valve assembly of any one of the preceding claims, wherein said lower extremity of said frame (10) presents an opening out (12) or is flared. 30
10. The prosthetic valve assembly of any one of the preceding claims, wherein said upper extremity of said frame (10) presents an opening out (12) or is flared. 35
11. The prosthetic valve assembly of any one of the preceding claims, wherein the frame (10) has a grate type design for supporting said valvular structure (14) and behaving as a scaffold for said stenotic native aortic valve. 40
12. The prosthetic valve assembly of any one of the preceding claims, wherein said valvular structure (14) forms a continuous surface and is provided with guiding means (17). 45
13. The prosthetic valve assembly of claim 12, wherein said guiding means (17) create stiffened zones which induce said valvular structure (14) to follow a patterned movement when moving from a closed state to an open state. 50

#### Patentansprüche

1. Klappenprothesenanordnung zum Austausch einer

stenotischen natürlichen Aortenklappe, umfassend:

einen metallischen Rahmen (10), der mit einer Vielzahl von Stäben mit Durchmessern im Bereich von 0,1 bis 0,6 mm ausgebildet ist, wobei der Rahmen für die Implantation innerhalb der stenotischen natürlichen Aortenklappe und zum Standhalten einer Rückstoßkraft eines natürlichen Aortenannulus geeignet ist, wobei der Rahmen obere und untere Endbereiche hat, wobei der Rahmen auf einen komprimierten Außendurchmesser von 4,5 mm bis 5,7 mm zum Vorwärtsbewegen mittels einer Arterieneinführungsvorrichtung in eine Oberschenkelarterie eines Patienten unter Verwendung eines Katheterisierungsverfahrens einfaltbar ist, wobei der Rahmen für die Implantation in die stenotische Aortenklappe auf eine expandierte Position expandierbar ist, wobei der untere Endbereich des Rahmens eine Zickzacklinie bildet; eine einfaltbare Klappenstruktur (14), die an den Rahmen zwischen den oberen und unteren Endbereichen genäht ist, wobei die Klappenstruktur aus Pericard ausgebildet ist, wobei die Klappenstruktur eine geschlossene Position zum Aufhalten des Blutstroms in eine Richtung hat; und eine innere Abdeckung (19), die aus dem gleichen Gewebe wie die Klappenstruktur gefertigt ist, wobei die innere Abdeckung nur einen unteren Teil des Rahmens bedeckt, wobei die innere Abdeckung ein oberes Ende, das an die Klappenstruktur genäht ist, und ein unteres Ende hat, das an den unteren Endbereich des Rahmens entlang der Zickzacklinie genäht ist, wobei die innere Abdeckung an eine Wand des Rahmens genäht ist und sich entlang einer inneren Oberfläche der Wand des Rahmens nur zwischen der Klappenstruktur und dem unteren Endbereich des Rahmens erstreckt, um Räume zwischen Stäben des Rahmens auf dem unteren Teil des Rahmens zu bedecken und das Rückströmen von Blut durch die Wand des Rahmens unterhalb der Klappenstruktur zu verhindern, und wobei die Wand des Rahmens entlang eines oberen Teils des Rahmens unbedeckt ist, um den Durchgang von Blut von der Aorta zu den Koronareingängen zuzulassen.

2. Klappenprothesenanordnung gemäß Anspruch 1, wobei der Rahmen (10) einen komprimierten Außendurchmesser hat, der für das Einführen durch eine 18F-Arterieneinführungsvorrichtung geeignet ist. 50
3. Klappenprothesenanordnung gemäß Anspruch 1, wobei der Rahmen (10) einen komprimierten Außendurchmesser hat, der für das Einführen durch eine 16F-Arterieneinführungsvorrichtung geeignet ist. 55

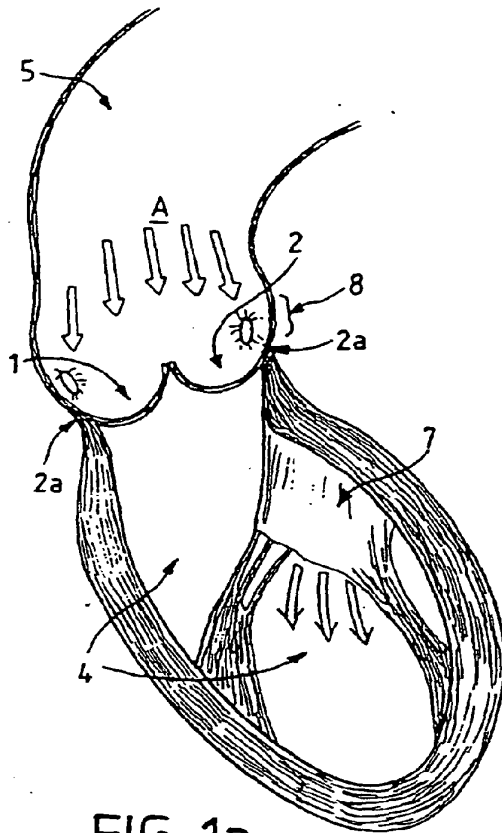
4. Klappenprothesenanordnung gemäß Anspruch 1, wobei der Rahmen (10) einen komprimierten Außendurchmesser hat, der für das Einführen durch eine 14F-Arterieneinführungsvorrichtung geeignet ist. 5
5. Klappenprothesenanordnung nach einem der Ansprüche 1 bis 4, wobei die expandierte Position des Rahmens (10) einen Außendurchmesser von etwa 20 bis 25 mm hat. 10
6. Klappenprothesenanordnung nach einem der vorhergehenden Ansprüche, wobei der Rahmen (10) aus einander kreuzenden Stäben gefertigt ist. 15
7. Klappenprothesenanordnung nach einem der vorhergehenden Ansprüche, wobei die innere Abdeckung (19) integral mit der Klappenstruktur (14) ist. 20
8. Klappenprothesenanordnung nach einem der vorhergehenden Ansprüche, wobei der Rahmen (10) ein im Allgemeinen konkaves Profil hat. 25
9. Klappenprothesenanordnung nach einem der vorhergehenden Ansprüche, wobei der untere Endbereich des Rahmens (10) eine Aufweitung (12) aufweist oder aufgetrichert ist. 30
10. Klappenprothesenanordnung nach einem der vorhergehenden Ansprüche, wobei das obere äußerste Ende des Rahmens (10) eine Aufweitung (12) aufweist oder aufgetrichert ist. 35
11. Klappenprothesenanordnung nach einem der vorhergehenden Ansprüche, wobei der Rahmen (10) eine gitterartige Konstruktion hat, um die Klappenstruktur (14) zu halten, und als ein Gerüst für die stenotische natürliche Aortenklappe dient. 40
12. Klappenprothesenanordnung nach einem der vorhergehenden Ansprüche, wobei die Klappenstruktur (14) eine zusammenhängende Fläche bildet und mit Führungsmitteln (17) versehen ist. 45
13. Klappenprothesenanordnung nach Anspruch 12, wobei die Führungsmittel (17) versteifte Zonen erzeugen, die dazu führen, dass die Klappenstruktur (14) einem Bewegungsablauf folgt, wenn sie von einem geschlossenen Zustand in einen offenen Zustand bewegt wird. 50

#### Revendications

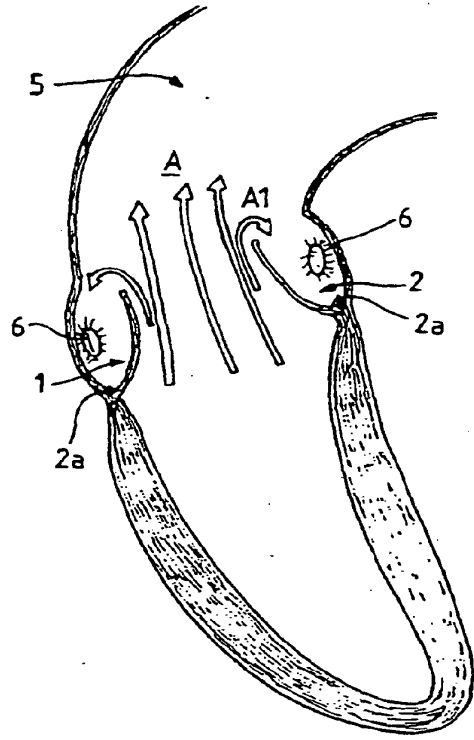
1. Ensemble de prothèse valvulaire pour remplacer une valvule aortique native sténosée, comprenant : 55
- un cadre métallique (10) formé d'une pluralité de barres ayant des diamètres dans la plage de 0,1 à 0,6 mm, ledit cadre étant approprié à l'implantation au sein de ladite valvule aortique native sténosée et pour résister à une force de recul d'un anneau aortique natif, ledit cadre ayant des extrémités supérieure et inférieure, ledit cadre étant pliable jusqu'à un diamètre externe comprimé de 4,5 mm à 5,7 mm pour l'avancée à travers un dispositif d'introduction artérielle dans l'artère fémorale d'un patient en utilisant une technique de cathétérisation, ledit cadre pouvant être expansé vers une position expansée pour l'implantation au sein de ladite valvule aortique native sténosée, ladite extrémité inférieure dudit cadre formant une ligne en zigzag ; une structure valvulaire pliable (14) suturée audit cadre entre lesdites extrémités supérieure et inférieure, ladite structure valvulaire étant formée du péricarde, ladite structure valvulaire ayant une position fermée pour occlure l'écoulement sanguin dans une direction ; et un recouvrement interne (19) réalisé avec le même tissu que ladite structure valvulaire, ledit recouvrement interne recouvrant uniquement une partie inférieure dudit cadre, ledit recouvrement interne ayant une extrémité supérieure suturée à ladite structure valvulaire et une extrémité inférieure suturée à ladite extrémité inférieure dudit cadre le long de ladite ligne en zigzag, ledit recouvrement interne étant suturé à une paroi dudit cadre et s'étendant le long d'une surface interne de ladite paroi dudit cadre uniquement entre ladite structure valvulaire et ladite extrémité inférieure dudit cadre pour couvrir des espaces entre lesdites barres dudit cadre sur ladite partie inférieure dudit cadre et empêcher la régurgitation de sang à travers ladite paroi dudit cadre en dessous de ladite structure valvulaire, et dans lequel ladite paroi dudit cadre est découverte le long d'une partie supérieure dudit cadre pour permettre le passage de sang de l'aorte aux ostia coronaires.
2. Ensemble de prothèse valvulaire selon la revendication 1, dans lequel ledit cadre (10) a un diamètre externe comprimé approprié à l'introduction à travers un dispositif d'introduction artérielle 18F. 50
3. Ensemble de prothèse valvulaire selon la revendication 1, dans lequel ledit cadre (10) a un diamètre externe comprimé approprié à l'introduction à travers un dispositif d'introduction artérielle 16F. 55
4. Ensemble de prothèse valvulaire selon la revendication 1, dans lequel ledit cadre (10) a un diamètre externe comprimé approprié à l'introduction à travers un dispositif d'introduction artérielle 14F.

5. Ensemble de prothèse valvulaire selon l'une quelconque des revendications 1 à 4, dans lequel ladite position expansée dudit cadre (10) a un diamètre externe d'environ 20 à 25 mm. 5
6. Ensemble de prothèse valvulaire selon l'une quelconque des revendications précédentes, dans lequel ledit cadre (10) est réalisé avec des barres s'entrecroisant. 10
7. Ensemble de prothèse valvulaire selon l'une quelconque des revendications précédentes, dans lequel ledit recouvrement interne (19) fait partie intégrante de ladite structure valvulaire (14). 15
8. Ensemble de prothèse valvulaire selon l'une quelconque des revendications précédentes, dans lequel ledit cadre (10) a un profil généralement concave. 20
9. Ensemble de prothèse valvulaire selon l'une quelconque des revendications précédentes, dans lequel ladite extrémité inférieure dudit cadre (10) présente une ouverture vers l'extérieur (12) ou est évasée. 25
10. Ensemble de prothèse valvulaire selon l'une quelconque des revendications précédentes, dans lequel ladite extrémité supérieure dudit cadre (10) présente une ouverture vers l'extérieur (12) ou est évasée. 30
11. Ensemble de prothèse valvulaire selon l'une quelconque des revendications précédentes, dans lequel le cadre (10) a une conception de type grille pour supporter ladite structure valvulaire (14) et se comportant comme un échafaudage pour ladite valve aortique native sténosée. 35
12. Ensemble de prothèse valvulaire selon l'une quelconque des revendications précédentes, dans lequel ladite structure valvulaire (14) forme une surface continue et est pourvue de moyens de guidage (17). 40
13. Ensemble de prothèse valvulaire selon la revendication 12, dans lequel lesdits moyens de guidage (17) créent des zones rigidifiées qui induisent ladite structure valvulaire (14) à suivre un mouvement structuré lors du déplacement d'un état fermé à un état ouvert. 50

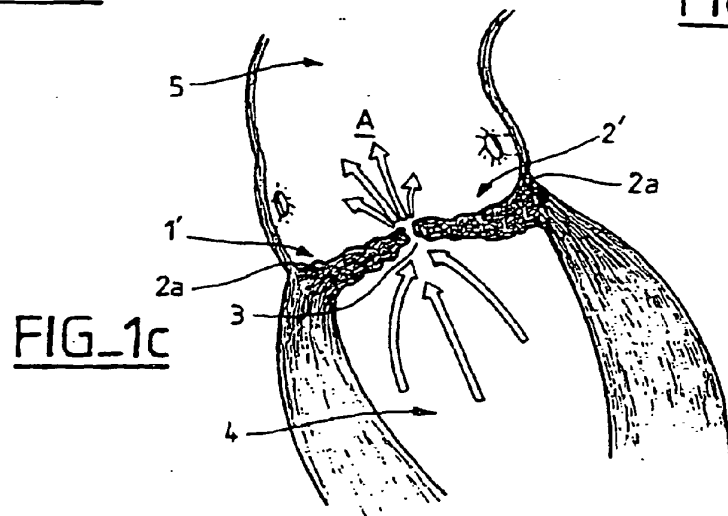
55



FIG\_1a



FIG\_1b



FIG\_1c



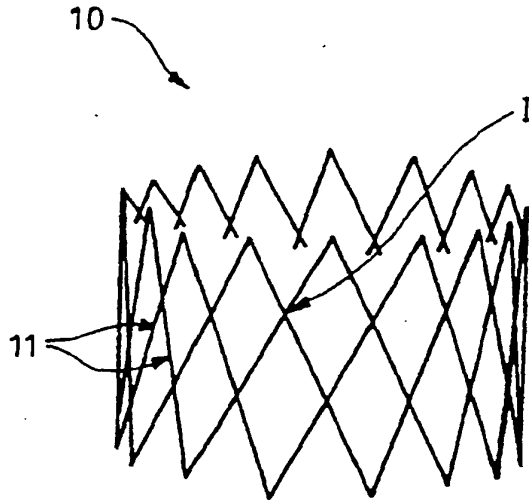


FIG. 2a

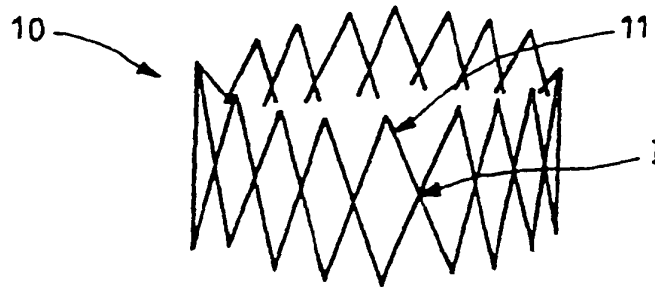
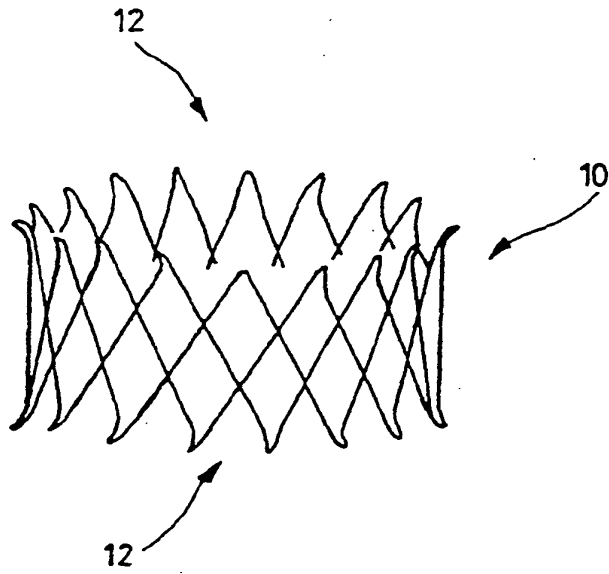
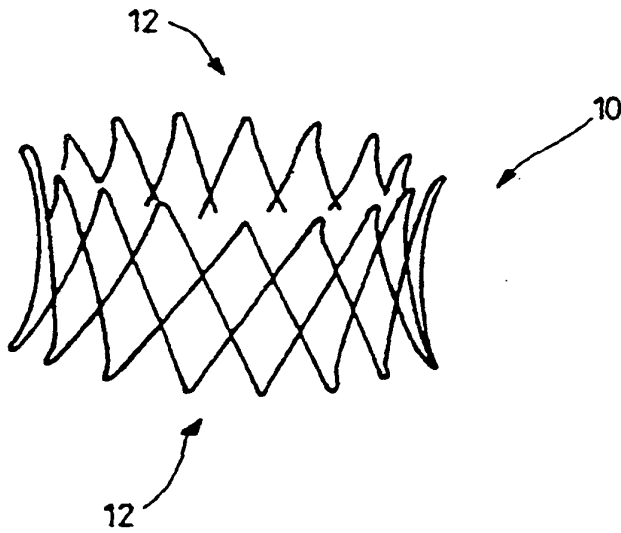


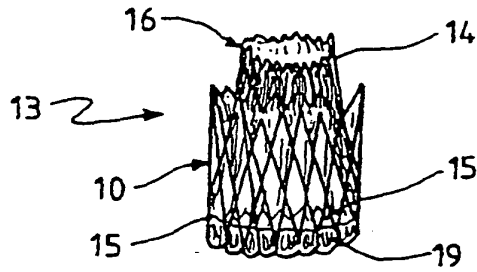
FIG. 2b



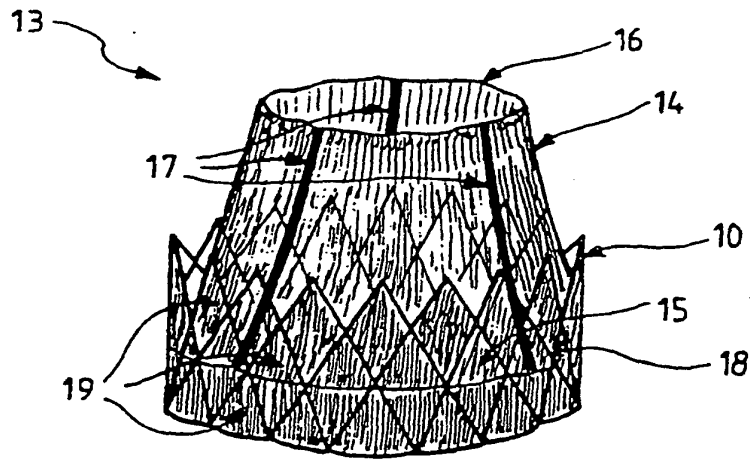
FIG\_3a



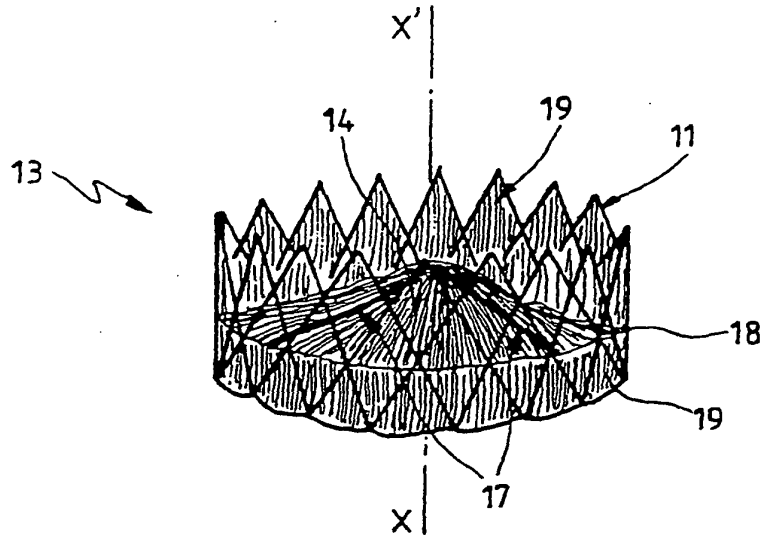
FIG\_3b



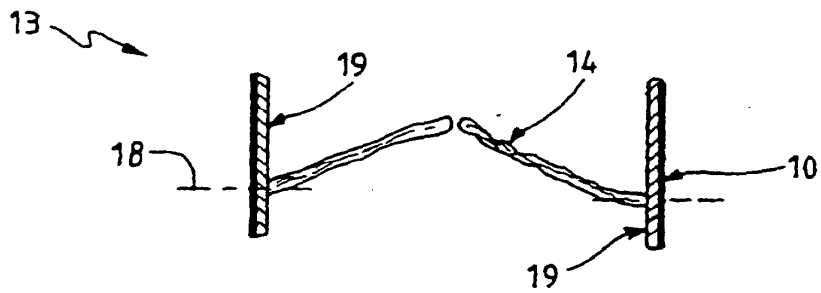
FIG\_4a



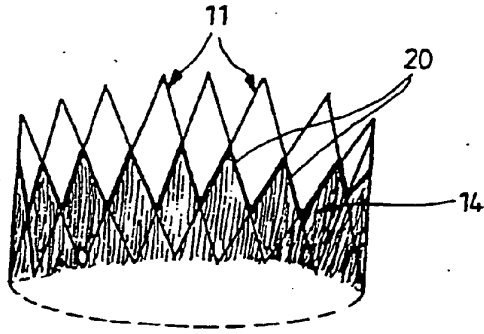
FIG\_4b



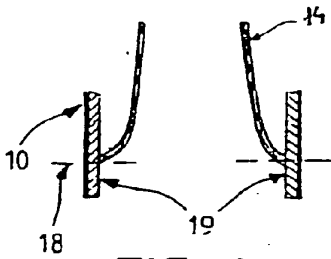
FIG\_5a



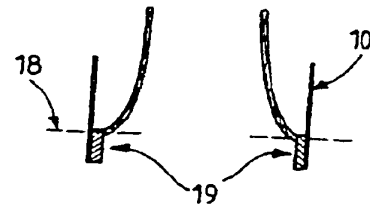
FIG\_5b



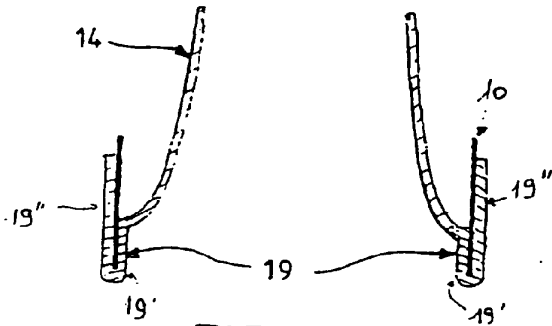
FIG\_7



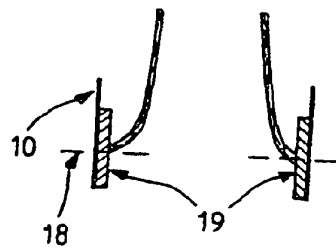
FIG\_6a



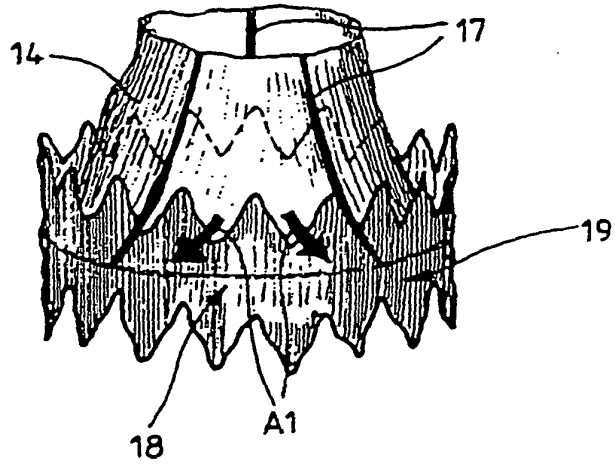
FIG\_6b



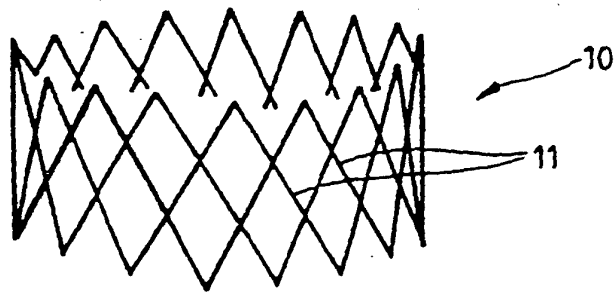
FIG\_6d



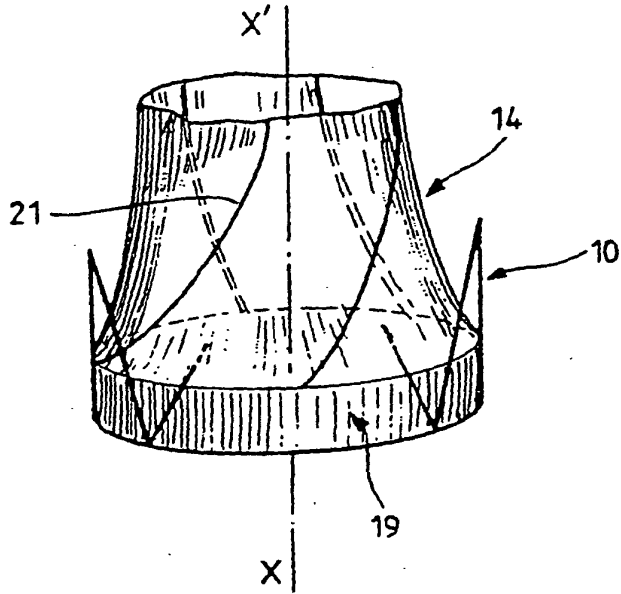
FIG\_6c



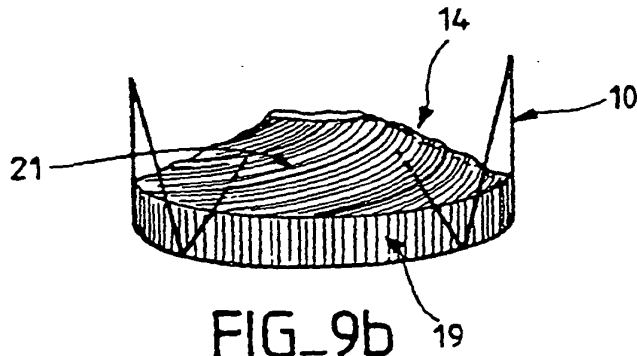
FIG\_8a



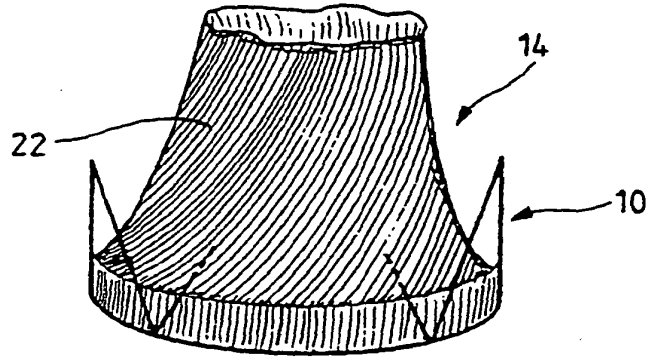
FIG\_8b



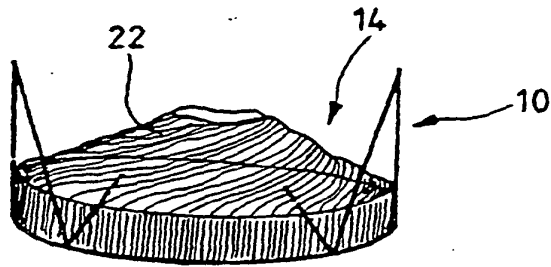
FIG\_9a



FIG\_9b

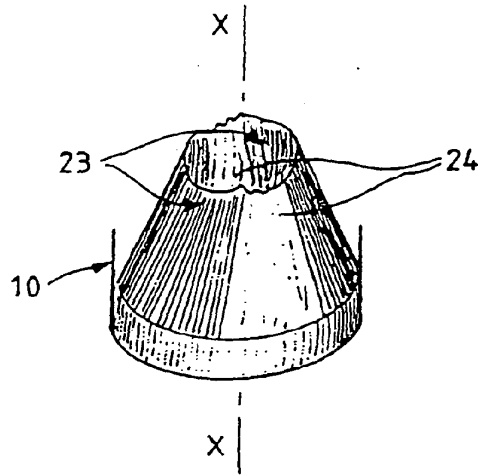


FIG\_10a

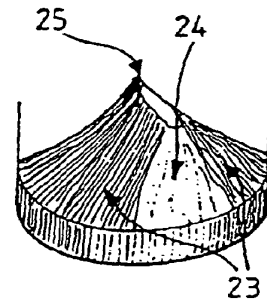


FIG\_10b

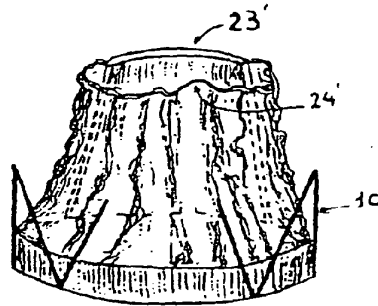




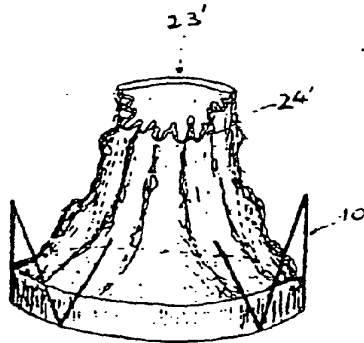
FIG\_11a



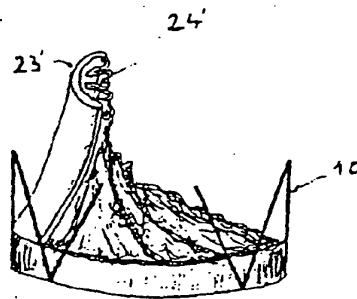
FIG\_11b



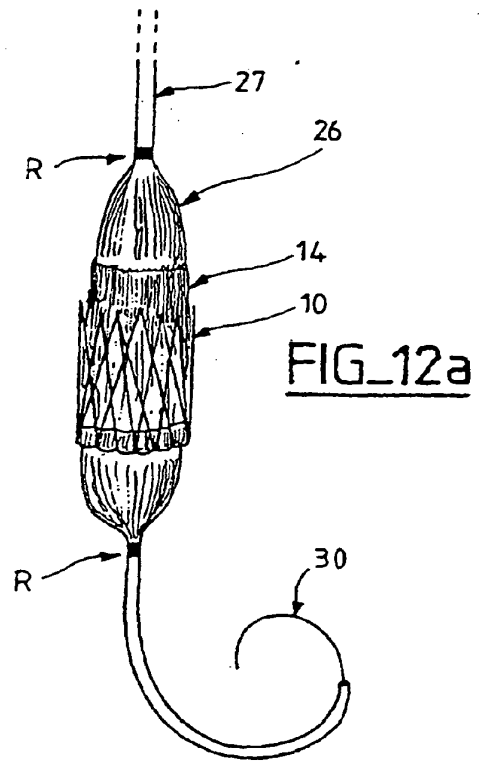
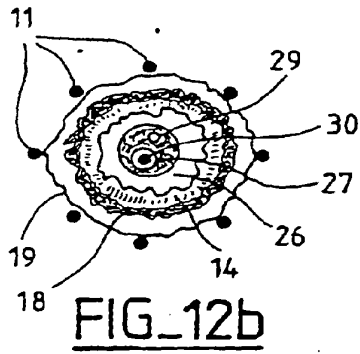
FIG\_11c



FIG\_11d



FIG\_11e



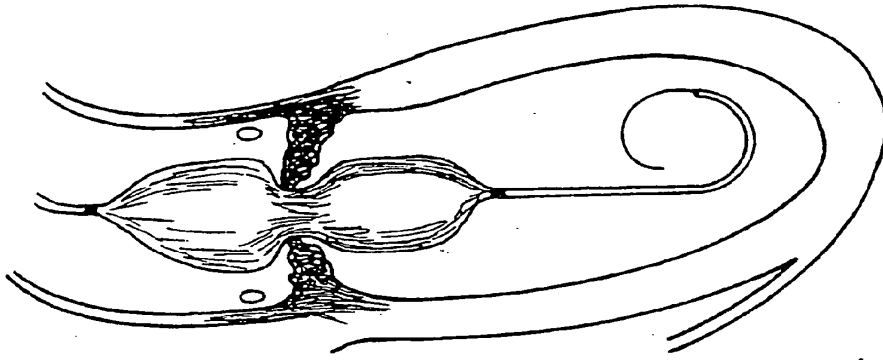


FIG-13c

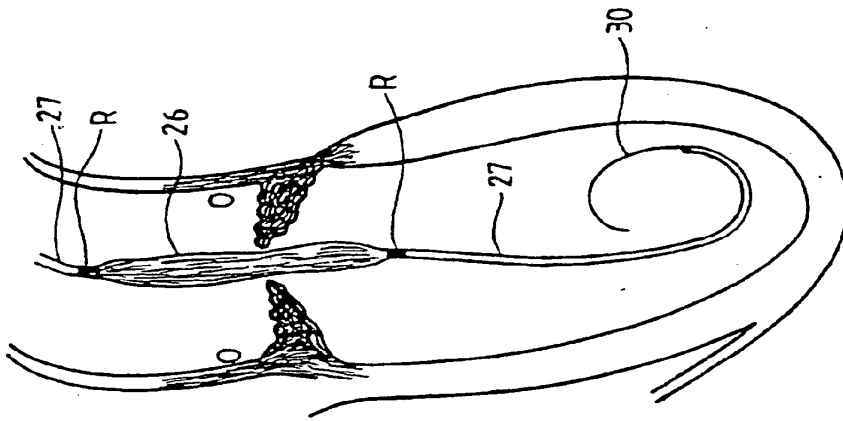


FIG-13b

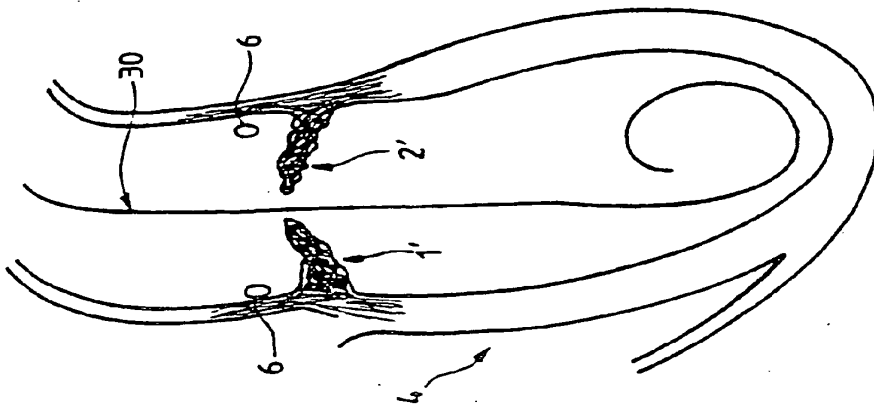


FIG-13a

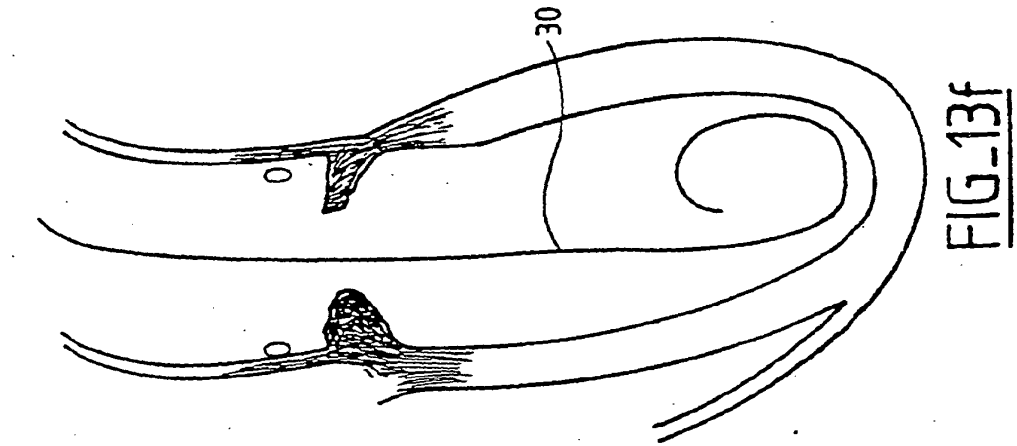


FIG-13f

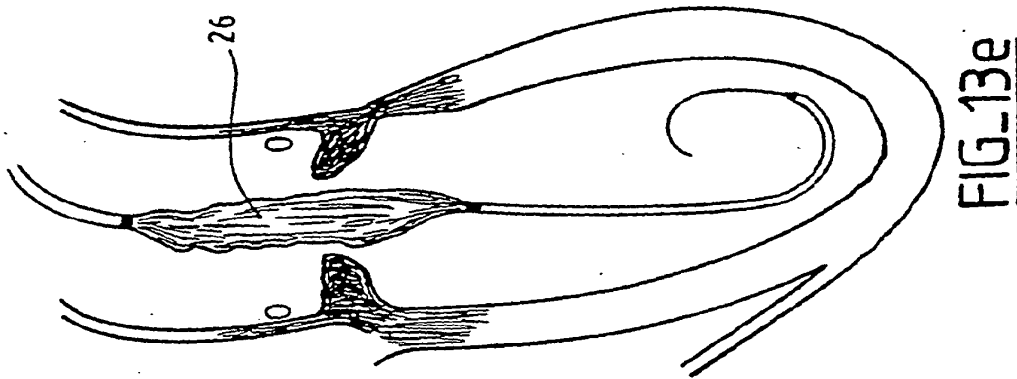


FIG-13e

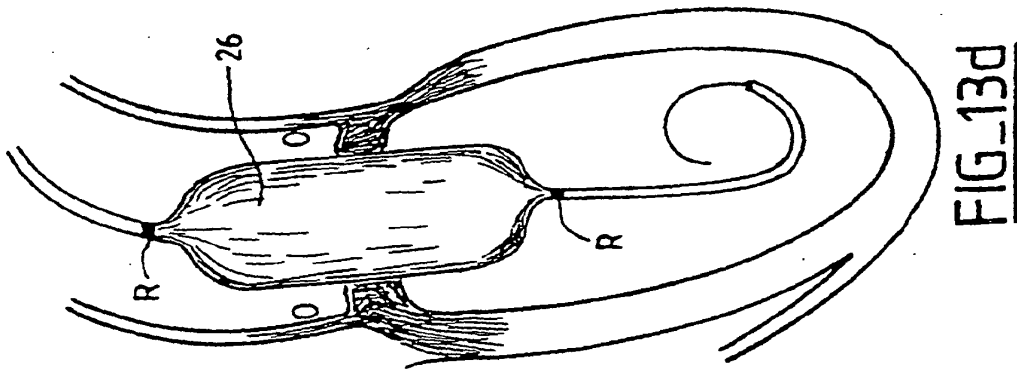


FIG-13d

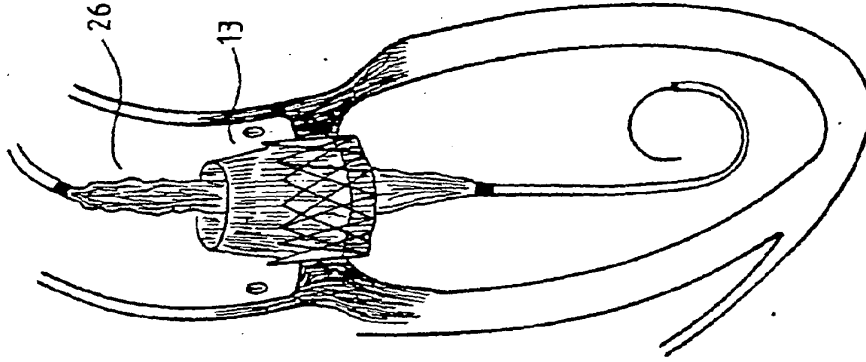


FIG. 13i

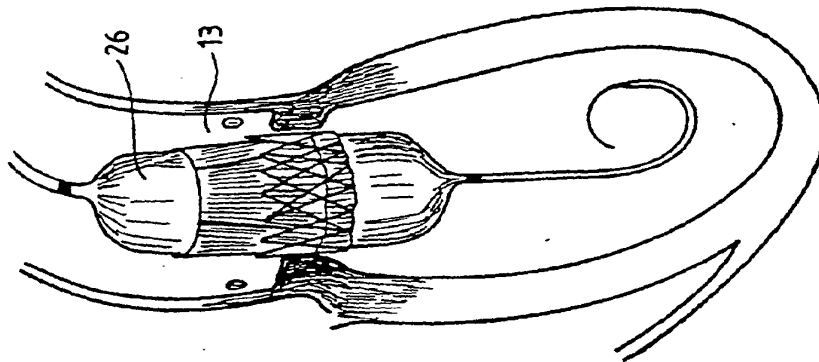


FIG. 13h

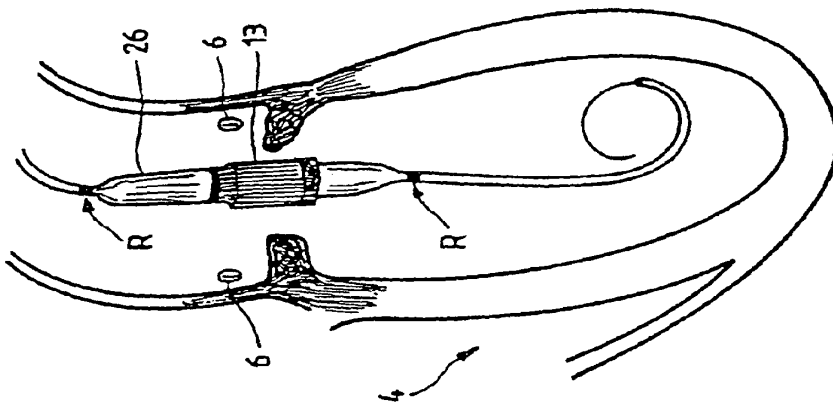


FIG. 13g

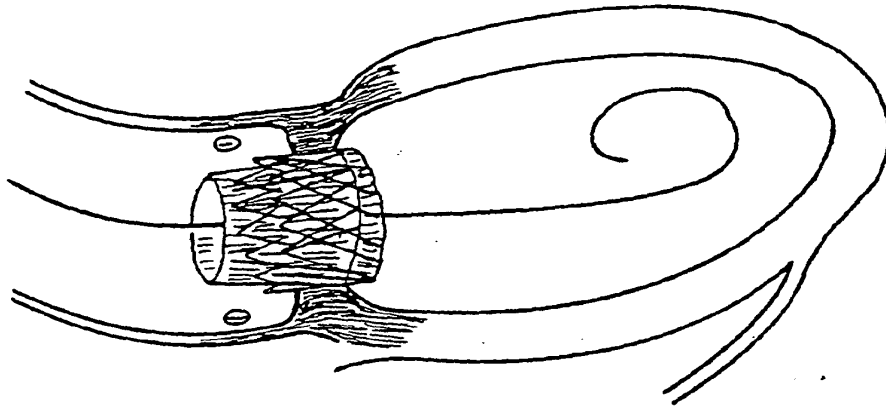


FIG-13l

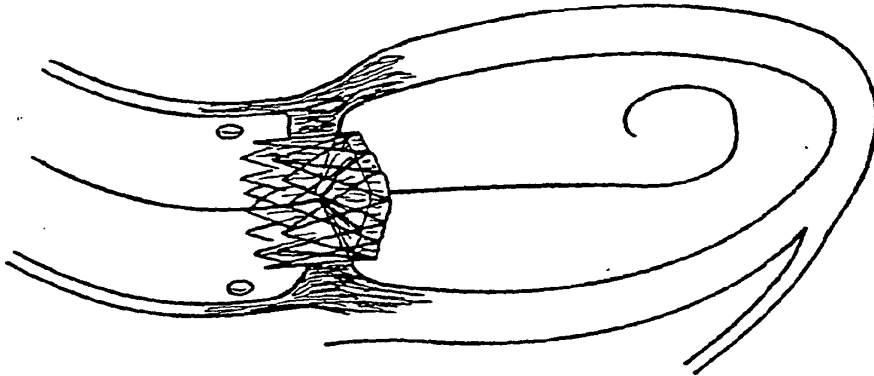


FIG-13k

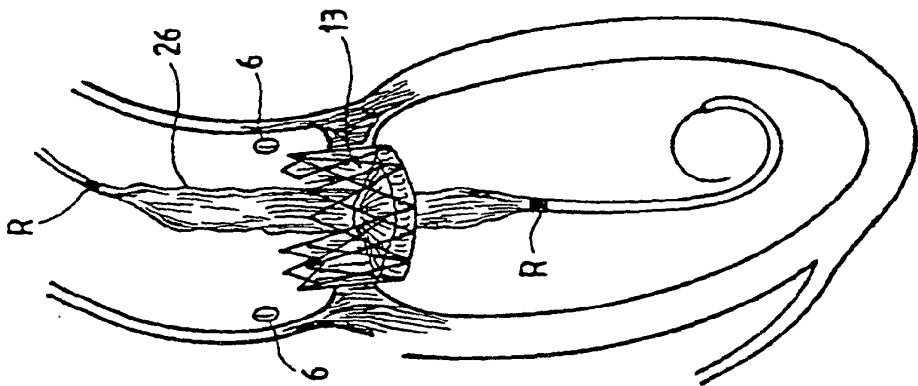
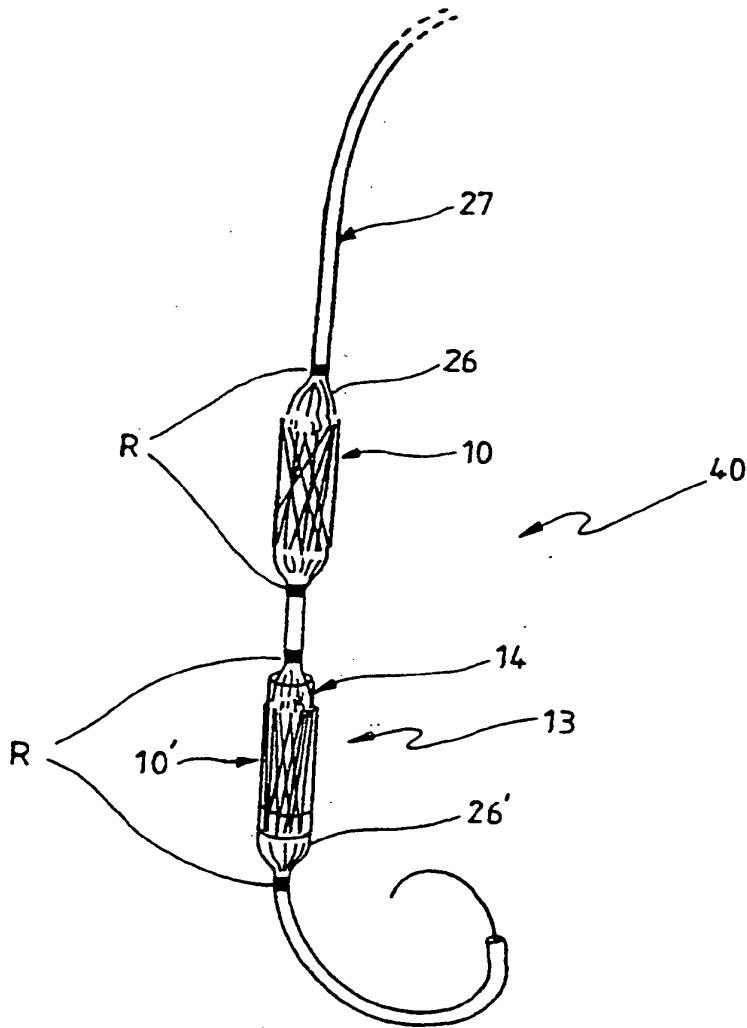
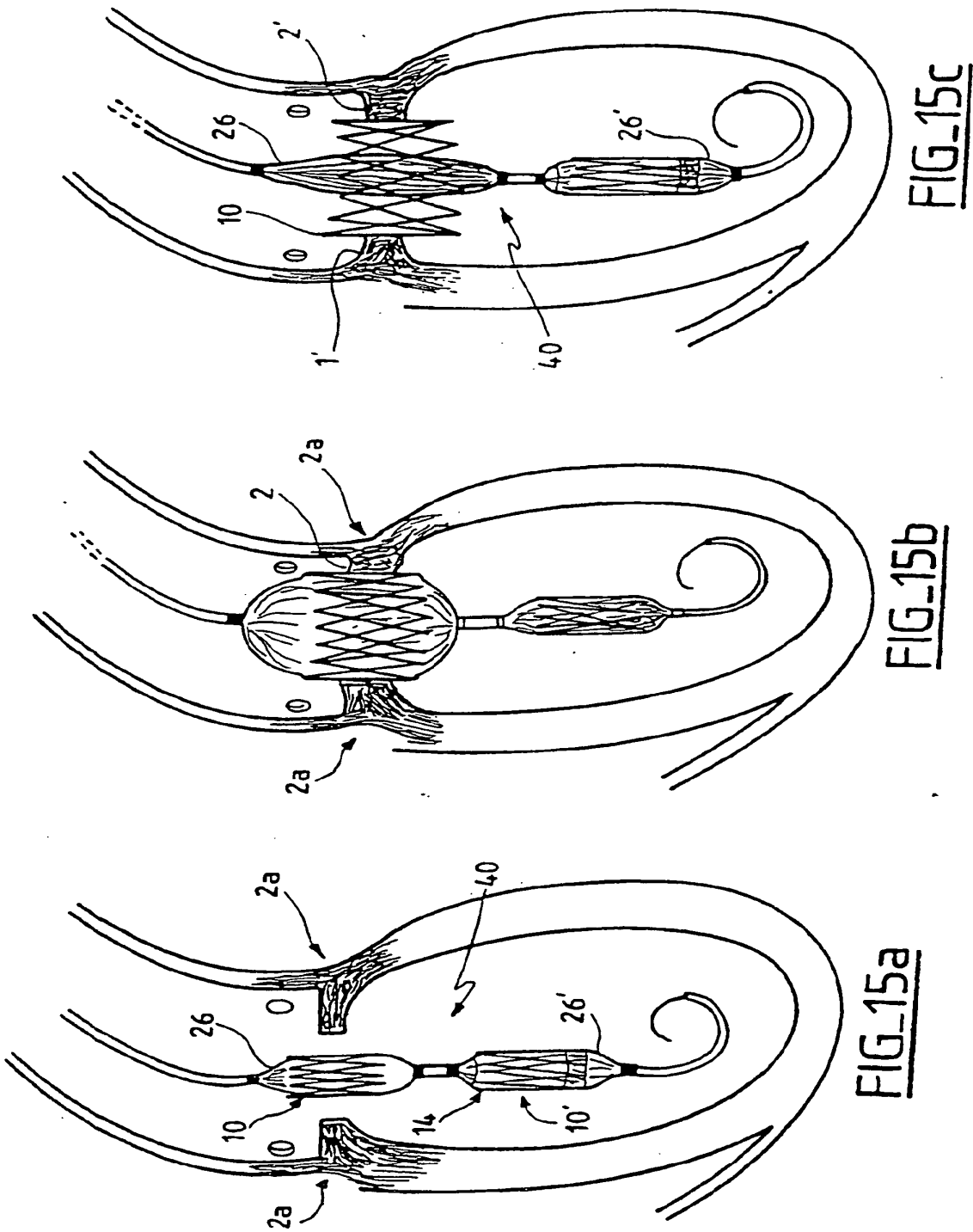


FIG-13j

FIG\_14







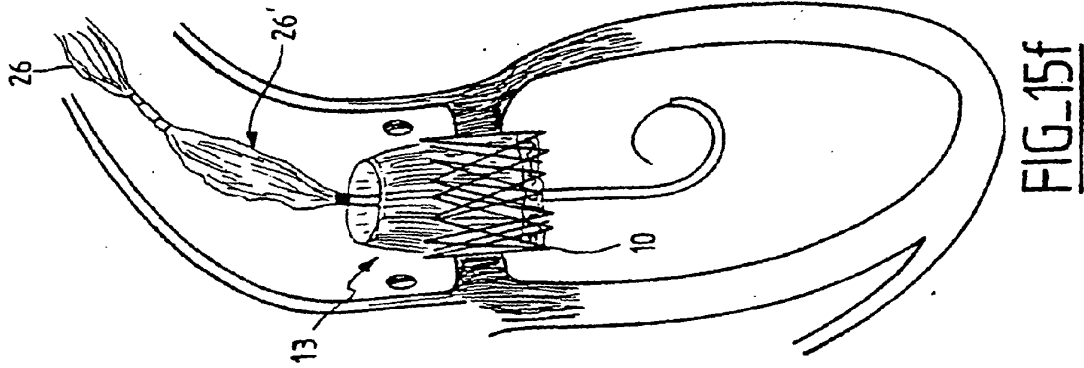


FIG-15f

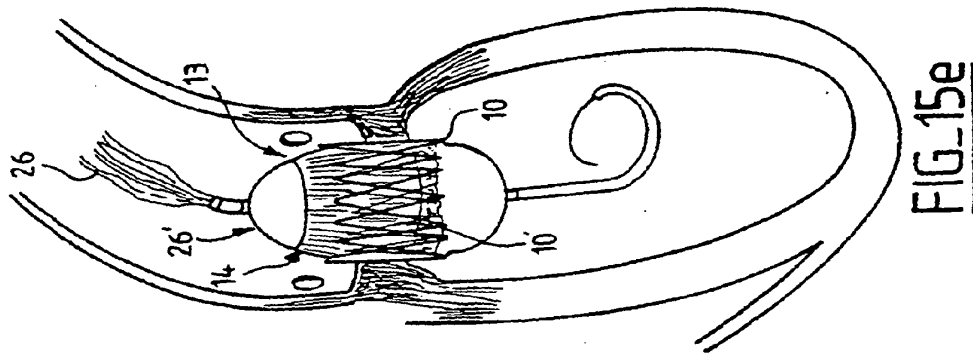


FIG-15e

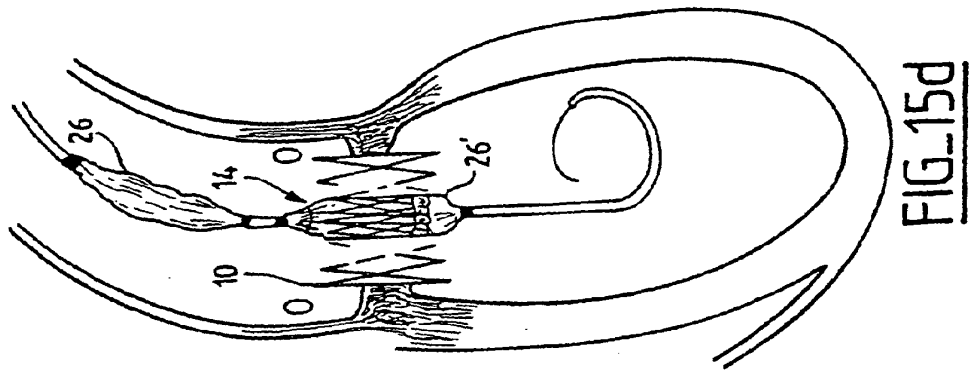


FIG-15d

**REFERENCES CITED IN THE DESCRIPTION**

*This list of references cited by the applicant is for the reader's convenience only. It does not form part of the European patent document. Even though great care has been taken in compiling the references, errors or omissions cannot be excluded and the EPO disclaims all liability in this regard.*

**Patent documents cited in the description**

- US 5411552 A [0014]
- WO 9301768 A [0017]

**Non-patent literature cited in the description**

- **M. D. DAKE.** *New Engl. J Med.*, 1994, vol. 331, 1729-34 [0102]



RU 2007 117 482 A

(51) МПК  
A61F 2/24 (2006.01)

ФЕДЕРАЛЬНАЯ СЛУЖБА  
ПО ИНТЕЛЛЕКТУАЛЬНОЙ СОБСТВЕННОСТИ,  
ПАТЕНТАМ И ТОВАРНЫМ ЗНАКАМ

(12) ЗАЯВКА НА ИЗОБРЕТЕНИЕ

(21), (22) Заявка: 2007117482/14, 10.05.2007

(43) Дата публикации заявки: 20.11.2008 Бюл. № 32

Адрес для переписки:  
650002, г. Кемерово, ул. Сосновый бульвар, 6,  
И.Ю. Журавлевой

(71) Заявитель(и):  
Закрытое акционерное общество "НеоКор" (ЗАО  
"НеоКор") (RU)

(72) Автор(ы):  
Барбараш Леонид Семенович (RU),  
Журавлева Ирина Юрьевна (RU),  
Щеглова Наталья Александровна (RU)

(54) БИОЛОГИЧЕСКИЙ ПРОТЕЗ КЛАПАНА СЕРДЦА И СПОСОБ ЕГО ИЗГОТОВЛЕНИЯ

(57) Формула изобретения

1. Биологический протез клапана сердца, включающий одноконтурный гибкий опорный каркас с тремя стойками, покрытый биосовместимым материалом, и запирающий элемент, выполненный в виде трех прикрепленных к каркасу створок, сформированных из аортального клапана свиньи или из ксеноперикарда, отличающийся тем, что его каркас содержит три осесимметричные дуги, соединяющие вершины комиссур и проходящие по основаниям створок, причем каркас помещен в оболочку из биосовместимого материала, полностью повторяющую форму каркаса по верхнему контуру, а нижняя часть оболочки биопротеза аортального клапана повторяет контур фиброзного кольца аортального клапана реципиента, формируя пришивную манжету, а при изготовлении атриовентрикулярного биопротеза к облицовке каркаса фиксируется пришивная манжета, расположенная снаружи от каркаса.

2. Биологический клапан сердца по п.1, отличающийся тем, что для изготовления оболочки каркаса используют ксеноперикард или другой биосовместимый материал.

3. Способ изготовления биологического протеза клапана сердца, включающий отбор аортальных комплексов, отмычку их в солевых изотонических растворах, препаровку и обработку с последующей фиксацией на опорном каркасе, отличающийся тем, что три изолированные створки клапана соединяют швами с формированием единых комиссур и фиксируют их на опорном каркасе в зонах вершин комиссур и оснований створок с захватом его в шов, а также по верхнему контуру каркаса без захвата его в шов, при этом приточный отдел клапана фиксируют непрерывным швом с захлестом к основанию каркаса.

4. Способ изготовления биологического протеза клапана сердца по п.3, отличающийся тем, что при использовании в качестве запирающего элемента створок, сформированных из ксеноперикарда, фиксацию по всей линии крепления створок осуществляют с захватом в шов каркаса, при этом пришивную манжету биопротеза клапана формируют из дубликатуры оболочки.

RU 2007117482 A

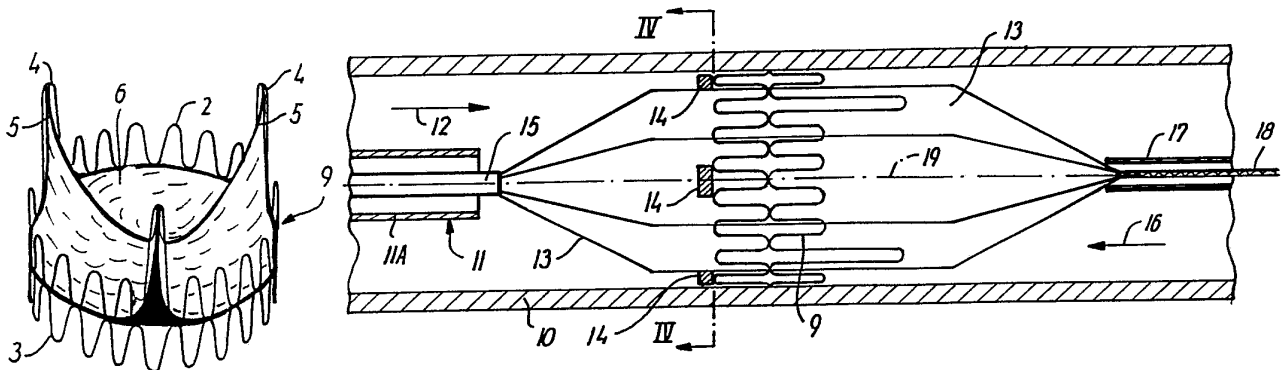
RU 2007117482 A



## INTERNATIONAL APPLICATION PUBLISHED UNDER THE PATENT COOPERATION TREATY (PCT)

<p>(51) International Patent Classification <sup>5</sup> : <b>A61F 2/24, A61M 25/10</b></p>	<p><b>A1</b></p>	<p>(11) International Publication Number: <b>WO 91/17720</b> (43) International Publication Date: 28 November 1991 (28.11.91)</p>
<p>(21) International Application Number: PCT/DK91/00134 (22) International Filing Date: 16 May 1991 (16.05.91) (30) Priority data: 1246/90 18 May 1990 (18.05.90) DK (71)(72) Applicants and Inventors: ANDERSEN, Henning, Rud [DK/DK]; Dalvangen 37A, DK-8270 Hoejbjerg (DK). HASENKAM, John, Michael [DK/DK]; Aprilvej 8, DK-8210 Aarhus V (DK). KNUDSEN, Lars, Lyhne [DK/DK]; Rudolf Wulffsgade 6, 4.mf, DK-8000 Aarhus C (DK). (74) Agent: LEHMANN &amp; REE; Grundtvigsvej 37, DK-1864 Frederiksberg C (DK).</p>		<p>(81) Designated States: AT (European patent), AU, BE (European patent), CA, CH (European patent), DE (European patent), DK (European patent), ES (European patent), FI, FR (European patent), GB (European patent), GR (European patent), IT (European patent), JP, LU (European patent), NL (European patent), NO, SE (European patent), US.  <b>Published</b> <i>With international search report.</i> <i>In English translation (filed in Danish).</i></p>

(54) Title: A VALVE PROSTHESIS FOR IMPLANTATION IN THE BODY AND A CATHETER FOR IMPLANTATING SUCH VALVE PROSTHESIS



## (57) Abstract

A valve prosthesis (9) for implantation in the body by use of catheter (11) comprises a stent made from an expandable cylinder-shaped thread structure (2, 3) comprising several spaced apices (4). The elastically collapsible valve (6) is mounted on the stent as the commissural points (5) of the valve (6) is secured to the projecting apices (4). The valve prosthesis (9) can be compressed around the balloon means (13) of the balloon catheter (11) and be inserted in a channel, for instance in the aorta (10). When the valve prosthesis is placed correctly the balloon means (13) is inflated thereby expanding the stent and wedging it against the wall of aorta. The balloon means is provided with beads (14) to ensure a steady fastening of the valve prosthesis on the balloon means during insertion and expansion. The valve prosthesis (9) and the balloon catheter (11) make it possible to insert a cardiac valve prosthesis without a surgical operation comprising opening the thoracic cavity.

**FOR THE PURPOSES OF INFORMATION ONLY**

Codes used to identify States party to the PCT on the front pages of pamphlets publishing international applications under the PCT.

AT	Austria	ES	Spain	MG	Madagascar
AU	Australia	FI	Finland	ML	Mali
BB	Barbados	FR	France	MN	Mongolia
BE	Belgium	GA	Gabon	MR	Mauritania
BF	Burkina Faso	GB	United Kingdom	MW	Malawi
BG	Bulgaria	GN	Guinea	NL	Netherlands
BJ	Benin	GR	Greece	NO	Norway
BR	Brazil	HU	Hungary	PL	Poland
CA	Canada	IT	Italy	RO	Romania
CF	Central African Republic	JP	Japan	SD	Sudan
CG	Congo	KP	Democratic People's Republic of Korea	SE	Sweden
CH	Switzerland	KR	Republic of Korea	SN	Senegal
CI	Côte d'Ivoire	LI	Liechtenstein	SU	Soviet Union
CM	Cameroon	LK	Sri Lanka	TD	Chad
CS	Czechoslovakia	LU	Luxembourg	TG	Togo
DE	Germany	MC	Monaco	US	United States of America
DK	Denmark				

A VALVE PROSTHESIS FOR IMPLANTATION IN THE BODY AND A CATHETER FOR IMPLANTING SUCH VALVE PROSTHESIS.

Background of the Invention.

The present invention relates to a valve prosthesis, preferably a cardiac valve prosthesis, for implantation in the body by means of a technique of catheterization and of the type comprising a collapsible elastical valve which is mounted on an elastical stent.

Valve prostheses of this type are usually implanted in one of the channels of the body to replace a natural valve. In the present description the invention will be explained in connection with an cardiac valve prosthesis for implantation in aorta. However, it will be possible to use a valve prosthesis according to the invention in connection with implantation in other channels in the body by using the same technique as the one used for implantation of cardiac valve prosthesis. Such an implantation may e.g. comprise the implantation of:

1. a valve (for instance a cardiac valve) in the veins,
2. a valve in the oesophagus and at the stomach,
3. a valve in the ureter and/or the vesica,
4. a valve in the biliary passages,
5. a valve in the lymphatic system, and
6. a valve in the intestines.

An existing natural valve in the body is traditionally replaced with a valve prosthesis by a surgical implantation. However, a surgical implantation is often an exacting operation. Thus, today the implantation of cardiac valves are solely made by surgical technique where the choracic cavity is opened. The operation calls for the use of a heart and lung machine for extern circulation of the blood as the heart is stopped and opened during the surgical intervention and the artificial cardiac valves are subsequently sewed in.

Due to its exacting character it is impossible to offer such operation to certain people. For instance this is due to the fact that the person is physically weak because of age or illness. Moreover, the number of heart and lung machines available at a hospital will be a substantially limiting factor.

Cardiac valve prostheses that need no surgical intervention are known

as there are used for implantation by means of a technique of catheterization. Examples of such valve prostheses are described in US Patent specifications Nos. 3,671,979 and 4,056,854. However, both these valve prostheses are connected to means which lead to the surface of the patient either for a subsequent activation of the valve or for a subsequent reposition or removal of the valve prosthesis. With these valve prostheses it is impossible to make an implantation which makes it possible for the patient to resume a substantially normal life in the same way as it is possible in connection with a surgical implantation of a cardiac valve.

From US Patent specification No. 3,755,823 an elastic stent for a cardiac valve prosthesis is known. However, this valve prosthesis is not designed for implantation in the body by catheterization. Even though the Patent specification contains no detailed explanation the description indicates that this valve prosthesis is designed for implantation and sewing on by a surgical intervention.

Moreover, from the US Patent specifications Nos. 4,856,516 and 4,733,665 different shapes of expandable stents are known. These stents are made to be expanded by impression of a radially outward force coming from a balloon catheter or the like. These stents are made to reinforce the wall when there is a risk that the channel is closed and/or compressed.

It is the object of the present invention to provide a valve prosthesis of the type mentioned in the introductory part, which permits implantation without surgical intervention in the body and by using a catheter technique known per se and which makes it possible for the patient to resume a substantially normal life.

This is achieved according to the invention with a valve prosthesis of the type mentioned in the introductory part, which is characterized in that the stent is made from an expandable cylindrical support means and that the commissural points of the elastical collapsible valve are mounted on the cylinder surface of the support means for folding and expanding together with the cylindrical support means.

The collapsible elastic valve is mounted on the stent for instance by

gluing, welding or by means of a number of suitable sutures.

5 If the support means are made from a thread structure this can for instance be grate shaped, loop shaped or helical. This makes it possible to compress the stent and the collapsible valve mounted thereon for placing on the insertion catheter. The use of a non-self-expandable stent may e.g. be effected by a compression of the stent around the expansion arrangement of the catheter which preferably consists of a balloon. When using a self-expandable stent a catheter with an expansion arrangement is not used. In this case the stent is compressed and is inserted into an insertion or protection cap from which the stent is eliminated after implantation in order to obtain an expansion due to the stresses in the compressed support means which for instance may be made from plastics or metal. After the compression the entire outer dimension is relatively small which makes it possible to introduce the valve prosthesis through a channel in the body.

20 When the valve prosthesis is introduced and placed correctly the stent is expanded by self-expansion or by means of the expansion arrangement until the stent is given an outer dimension which is slightly larger than the channel in which it is placed. As the stent is elastic a contraction of the stent is prevented once it is expanded. The stiffness in the material of the support means contributes to maintain the expanded shape of the stent. After the expansion is made the expansion arrangement of the catheter is contracted and the catheter can be removed from the channel. The inlet opening can subsequently be closed and the patient will then be able to resume a normal life.

30 The valve prosthesis according to the invention does not require an actual operation but merely a small intervention to optionally expose the body channel, e.g. a vein, through which the insertion takes place. Thus patients for whom operation will be associated with high risk can be offered implantation of for instance cardiac valves. After the implantation has taken place the after-treatment will advantageously be shorter than normally which means fewer hospital days for the patient. Moreover, it is assumed that it will be possible to implantate the valve prosthesis under local anaesthetic.

The valve prosthesis can be used to replace a natural valve or to



establish a new valve function in one of the channels in the body which do not naturally contain a valve. For instance this goes for veins (arteries and veins) on a place without natural valves. The function of the valve prosthesis is then to ensure that the blood  
5 flows in one direction only. The valve is meant to be used in veins in the legs of persons suffering from varicose veins (varices).

In persons having varicose veins the blood flows in a wrong direction, viz. from the central veins in the centre of the leg towards the superficial veins. Among other things this is due to the changed pressure in the legs, upright working position and other conditions. A valve prosthesis according to the invention may easily be placed in the veins and prevent the flow of the blood in wrong direction.  
10

Also, the valve prosthesis can be used in connection with diseases, for instance cancerous tumours, where too much humour is produced. If the humour is able to flow from the cancerous tumour through several channels it is possible to drain the humour in one desired direction through the channels of the body by an appropriate placing of the valve prostheses.  
15  
20

When the valve prosthesis is used as cardiac valve prosthesis in the aorta it is possible to mount it in three positions, viz. in the descending part of the aorta, in a position between the coronary arteries and the left ventricle of the heart or in the aorta in a position immediately after the mouth of the coronary arteries.  
25

The cardiac valve prosthesis can also be used in other places than in the aorta. Thus the valve prosthesis can be used in the pulmonary artery and/or the right ventricle of the heart for replacing the pulmonary valves. Likewise the cardiac valve prosthesis can be used in the passage between the right auricle of the heart and the right ventricle of the heart (tricuspidalostium) and the passage between the left auricle of the heart and the left ventricle of the heart (mistralostium) for replacing the tricuspidal valve and the mitral valve, respectively.  
30  
35

Even though the cardiac valve preferably is meant to be used for patients suffering from aorta insufficiency and who can not be offered an open heart surgery the valve prosthesis can also be used for pa-

tients in connection with treatment of aorta stenosis. Several of the patients with aorta stenosis are elderly people who can not be offered a surgical cardiac operation. The patients are offered balloon dilatation of the aorta stenosis which may result in an aorta insufficiency as a side effect of the treatment.

As to these patients it is possible to insert a valve prosthesis in the descending or ascending part of the aorta thoracalis a few days or weeks before the balloon dilatation. As a result thereof the left ventricle is protected against weight if the subsequent balloon dilatation of the stenosis results in aorta insufficiency. In certain cases the weight (reflux) on the left ventricle is reduced by up to approximately 75%.

Furthermore, the stent may be made with a relatively great height and with a cylinder surface which is closed by a suitable material. Thus, a vascular prosthesis known per se is formed wherein the valve is mounted. This may facilitate the implantation of the valve prosthesis, for instance in the arcus aorta. Moreover, the great surface which abuts the inner wall of the channel contributes to ensure the securing of the valve prosthesis in the channel. This embodiment is also suitable as valve prosthesis which is inserted in veins. As veins have relatively thin and weaker walls than arteries it is desirable that the valve prosthesis has a greater surface to distribute the outward pressure which is necessary to secure the valve prosthesis.

Moreover, the invention relates to a balloon catheter for implantating a valve prosthesis according to the invention and comprising a channel for injection of a fluid for the inflation of the balloon means of the catheter and an insertion cap wherein the balloon means of the catheter and a collapsible valve prosthesis mounted thereon are located during the injection, characterized in that the balloon means are provided with a profiled surface which is made to ensure a steady fastening of the valve prosthesis during the elimination of the balloon means from the protection cap and the subsequent inflation for the expansion of the stent.

Different balloon catheters for implantating cores in the body are known. For instance such balloon catheters are known from US Patent

specifications Nos. 4,856,516, 4,733,665 and 4,796,629 and from DE publication No. 2,246,526. However, the known balloon catheters have a smooth or a slightly wavy surface. The use of such balloon catheter is disadvantageous for mounting a valve prosthesis in a channel having a large flow as for instance the aorta. A large humour flow is able to displace the stent on the smooth surface of the balloon and makes an accurate positioning difficult. This drawback has been remedied with the balloon catheter according to the present invention as the profiled surface prevent a displacement of the valve prosthesis in relation to the balloon means during introduction and the subsequent inflation of the balloon means.

In connection with the implantation any prior art technique may be used to supervise an accurate introduction and positioning of the valve prosthesis. Thus, guide wires for the catheter, X-ray supervision, injection of X-ray tracable liquids, ultrasonic measuring etc. may be used.

#### Description of the Drawings.

The invention will now be explained in details with reference to the accompanying schematical drawing, wherein

- Fig. 1 shows a perspective view of a stent without a valve,  
Fig. 2 a perspective view of a valve prosthesis according to the invention made from the stent shown in Fig. 1 having a biological valve mounted thereon,  
Fig. 3 a partial view through the aorta illustrating a partially inflated balloon catheter,  
Fig. 4 a cross section through the embodiment shown in Fig. 9,  
Fig. 5-7 views illustrating the introduction and implantation of a valve prosthesis of the invention in the aorta,  
Fig. 8-10 views illustrating three possible positions of a cardiac valve prosthesis, and  
Fig. 11-12 perspective views illustrating two further embodiments of a valve prosthesis having a closed cylindrical wall.

Fig. 1 shows a stent 1 made by support means in the form of two 0,55 mm surgical stainless steel wires 2,3. The wires are folded in 15

loops. Three loops 4 are 14 mm in height and intended to secure the commissural points 5 (see Fig. 2) from a biological cardiac valve 6 which is mounted in the stent 1. The remaining loops have a height of 8 mm. Each of the two folded wires 2,3 was bended to form rings 7,8 which were closed by welding the ends. The two rings are place on the top of each other as will appear from Fig. 1 and they are mutually secured by means of a number of sutures (not shown). By using a substantially cylindrical thread structure with projecting apices a reduction in weight is obtained compared to a stent which is exclusively cylindrical with the same loop heights for all the loops.

The biological valve 6 was removed from a slaughtered pig of 100 kg. The valve was cleaned before mounting in the stent 1. The cleaned valve has an outer diameter of 25-27 mm and the height of the three commissural points 5 is 8 mm. The valve 6 is mounted in the stent by means of a suitable number of sutures to form the cardiac valve prosthesis 9 shown in Fig. 2. The valve prosthesis produced is used for performing tests in pigs by implantation of cardiac valve prosthesis. However, the cardiac valve prosthesis for use in human beings has a corresponding form.

Fig. 3 shows a partiel view through the aorta 10. A balloon catheter 11 is introduced in the aorta according to the direction of an arrow 12. In the Figure shown the balloon means 13 of the balloon catheter is led out of the protection cap 11A and is partly inflated through a fluid channel 15, which is led to the surface of the patient. The balloon means 13 constitutes a tri-sectional balloon upon which the cardiac valve prosthesis is placed. In the form shown the cardiac valve prosthesis is expanded exactly to be in contact with the aorta 10. The balloon means 13 is provided with three projecting beads 14 which are engaged with the one side of the cardiac valve prosthesis 9. The blood flowing through the aorta according to the direction of an arrow 16 will thus cause the cardiac valve prosthesis 9 to abut on the beads 14 and the valve cannot be displaced in relation to the balloon means 13. Moreover, the balloon catheter used comprises a central channel 17 to receive a guide wire 18 which is used in a way known per se for supervising the introduction of the catheter through fluoroscopi. In the shown embodiment beads 14 are only used at one side of the valve prosthesis, but, however, it will often be desirable to use the beads in

pairs placed along lines parallel to the longitudinal axes 19 through the balloon means 13. In this case the spacing of the pair of beads 14 will correspond to the height of the loops of the stent. This makes it possible to make an effective fastening of a valve prosthesis on balloon means. Moreover, the fastening on the balloon means may be provided by using balloon means with an indentation in the surface (not shown).

Fig. 4 shows a cross section through the embodiment shown in Fig. 3 illustrating the placing of the beads 14 on the tri-sectional balloon means 13.

A balloon catheter of the above described type which was used in tests of implantating the cardiac valve prosthesis 9 in pigs had the following dimensions. Each of the three balloons is 60 mm in length and 15 mm in diameter. The total diameter for the three inflated balloons is 31 mm and in the balloon catheter used two beads 14 having a height of 3 mm are mounted on each side of the three balloons. The beads have a spacing of 15 mm. The protection cap 11A of the balloon catheter has an outer diameter of 13.6 mm and an inner diameter of 12.5 mm and a length of 75 cm. The balloon catheter is provided with a standard guide wire having a diameter of 0.9 mm and a length of 300 cm.

Figs. 5-7 show the valve prosthesis 9 at different steps in introducing and implantating in the aorta 10 by means of the catheter 11 having the inflatable balloon means 13. The cardiac valve prosthesis 9 is initially placed above the deflated balloon means 13 and compressed manually around the balloon means (Fig. 5), whereafter the outer diameter for the valve prosthesis is approximately 10 mm. After the introduction and positioning the balloon means 13 is inflated (Fig. 6) thereby contributing an outer dimension of approximately 30 mm to the cardiac valve prosthesis. To obtain an effective fastening in the aorta the outer dimension of the cardiac valve prosthesis is greater than the diameter of the aorta. This means that the prosthesis is tight against the inner wall of the aorta with a pressure which is sufficiently large to counteract a detachment due to the flow of the blood. The balloon catheter 11 may subsequently be removed from the aorta 10 (Fig. 7). Due to the stiffness of the metal the valve prosthesis will prevent a contraction. However, smaller contractions may occur (<10%

diameter reduction) after the deflation and removal of the balloon catheter 13. When the valve prosthesis is mounted as showed in Fig. 7 the patient will be able to resume a substantially normal life after a few days.

5

Figs. 8-10 show the positioning of the valve prosthesis 9 as cardiac valve prosthesis in the aorta 10 in three different positions. In a position between the coronary arteries 20 and the left ventricle of the heart 21 (Fig. 8). In a position immediately after the mouth of the coronary arteries in the ascending part of the aorta (Fig. 9). In a position in the descending part of the aorta 10. The positioning of the valve prosthesis is chosen in accordance with the diagnose of the illness of the patient. By placing the cardiac valve prosthesis as shown in Fig. 8 there is a risk of detachment and/or covering the mouth of the coronay arteries, and therefore it is preferred to use a higher stent which for instance comprises several rings 7,8 placed on top of each other. This allows a fixation of the prosthesis at a place after the mouth of coronary arteries even though the valve itself is in the position between the coronary arteries and the left ventricle. Fig. 8 and 9 show how a contrast medium 23 is injected by means of a so-called pigtail catheter for registration of the tightness of the implantated valve prosthesis 9.

A specific embodiment for a valve prosthesis and a balloon catheter for implantating the valve prosthesis has been explained above. However, it is obvious that it is possible to modify the valve prosthesis depending on the desired use, and moreover, it is possible to modify the catheter used in the implantation. Thus the stent of the valve prosthesis may be made solely of one closed ring folded in a number of loops or with three or more mutually secured loop-shaped rings placed on top of each other. Moreover, it is possible to make the stent having a thread structure which in stead of loops is grate shaped, helical or is formed otherwise if only it is ensured that the form of the stent permits the compression and expansion of the stent and fastening of the collapsible valve. In stead of a biological valve it might be possible to use other collapsible valves, such as valves made from synthetic materials, e.g. polyurethane. It is also possible to use valves with more or fewer flaps than three.

It is possible to make the valve prosthesis with a closed cylinder surface as illustrated in Figs. 11 and 12. In both Figures the support means of the valve prosthesis is made of an elongated tubular means 24 having a closed cylinder surface. This valve prosthesis is intended to expand by self-expansion or by means of a catheter according to the invention. This prosthesis is especially suitable for placing in veins and other channels where only a small pressure is exerted against the wall of the channel. In Fig. 11 the valve 6 is mounted at the end of the tubular means 24. In Fig. 12 an embodiment is showed where the valve 6 is mounted in a central position in the tubular means 24.

An explanation of a method of implantating a valve prosthesis according to the invention is given below:

- 15 - a valve prosthesis 9 made of a stent 1 and a collapsible valve 6, as described above,
- the valve prosthesis 9 is placed on a deflated balloon means and is manually compressed thereon,
- the balloon means 13 and the valve prosthesis are drawn into an insertion cover 11A,
- 20 - a guide wire 18 is inserted into the left ventricle of the heart through the central opening 17 of the balloon catheter under continuous fluoroscopy,
- the insertion cover 18 conveys the guide wire 18 to a point in the channel in immediate vicinity of the desired position of the valve prosthesis,
- 25 - the balloon means 13 is pushed out of the protection cap 11A and the valve prosthesis is positioned in the desired position if necessary by use of further registration means to ensure an accurate positioning,
- 30 - the balloon means 13 is inflated with a certain overstretching of the channel,
- the balloon means 13 is deflated, and
- the balloon means 13, the guide wire 18 and the protection cap 11A are drawn out and the opening in the channel, if any, wherein the valve prosthesis is inserted can be closed.
- 35

C L A I M S.

1. A valve prosthesis, preferably a cardiac valve prosthesis, for im-  
plantation in the body by means of a technique of catheterization and  
of the type comprising a collapsible elastical valve which is mounted  
on an elastical stent, c h a r a c t e r i z e d in that the stent is  
made from an expandable cylindrical support means and that the commis-  
sural points of the elastical collapsible valve are mounted on the cy-  
linder surface of the support means for folding and expanding together  
with the cylindrical support means.
2. A valve prosthesis according to claim 1, c h a r a c t e r i z e d  
in that the support means is made of a thread structure.
3. A valve prosthesis according to claim 2, c h a r a c t e r i z e d  
in that the thread structure comprises several spaced apices project-  
ing from the one side of the cylindrical structure and in direction  
along the longitudinal axis of the cylinder and that the commissural  
points of the valve are attached to the projecting apices.
4. A valve prosthesis according to claim 3, c h a r a c t e r i z e d  
in that the elastically collapsible valve is a biological trilobate  
valve.
5. A valve prosthesis according to claim 4, c h a r a c t e r i z e d  
in that the stent is made from a stainless steel wire folded in a num-  
ber of loops and bended according to a circle and welded to form a  
closed ring, that the stent comprises two or more such closed rings  
which are mutually connected end to end to form the cylindrical thread  
structure, that three of the loops in the external ring are folded  
with a greater height than the remaining loops to form the apices to  
which the commissural points of the biological valve are attached.
6. A valve prosthesis according to claim 5, c h a r a c t e r i z e d  
in that each of the rings of the stent is made from a wire having a  
diameter of 0.55 mm and a loop height of approximately 8 mm and appro-  
ximately 14 mm for the three greater loops, and that the cylindrical  
thread structure produced and the collapsible valve mounted thereon in  
a folded state have an outer diameter of approximately 10 mm and in



expanded state an outer diameter of approximately 30 mm.

- 5 7. A valve prosthesis according to claim 5, c h a r a c t e r i z e d in that three or more mutually attached rings placed on top of each other are used and that the stent is made to be fixed through the expansion at one point in the channel where the valve prosthesis is inserted, which point is different from the point where the valve is mounted in the stent.
- 10 8. A valve prosthesis according to any of the preceding claims, c h a r a c t e r i z e d in that the cylinder surface of the support means is closed to form a tubular element.
- 15 9. A balloon catheter for use in implantating a valve prosthesis according to any of the preceding claims and comprising a channel for injection of a fluid for the inflation of the balloon means of the catheter and an insertion cap wherein the balloon means of the catheter and a collapsible valve prosthesis mounted thereon are located during the injection, c h a r a c t e r i z e d in that the balloon means are provided with a profiled surface which is made to ensure a steady fastening of the valve prosthesis during the elimination of the balloon means from the protection cap and the subsequent inflation for expanding the stent.
- 20 10. A balloon catheter according to claim 9, c h a r a c t e r i z e d in that the profiling of the surface is made by beads or buds on the surface of the balloon means.
- 25 11. A balloon catheter according to claim 10, c h a r a c t e r i z e d in that the beads are placed in pairs in a number from four to eight along lines parallel with the longitudinal axis of the balloon means and with a spacing corresponding to the height of the stent used.
- 30 12. A balloon catheter according to claim 9, c h a r a c t e r i z e d in that the profiling of the surface is made by an indentation which is formed in the surface of the balloon means with an extension corresponding to the height of the stent used.
- 35

1/4

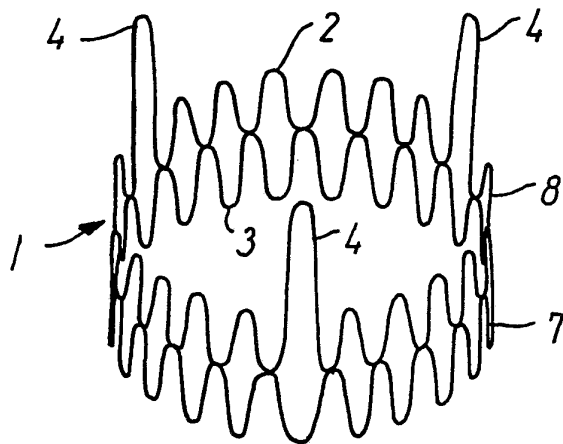


FIG. 1

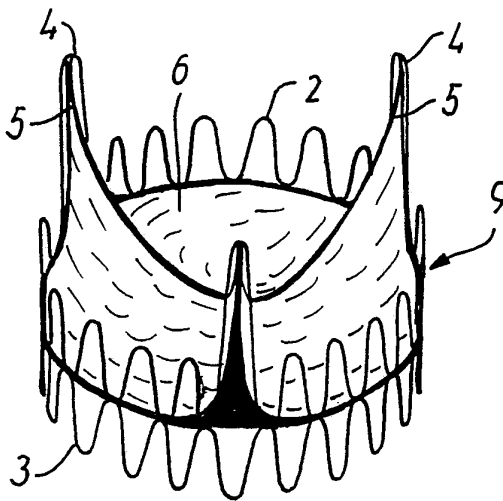


FIG. 2

2/4

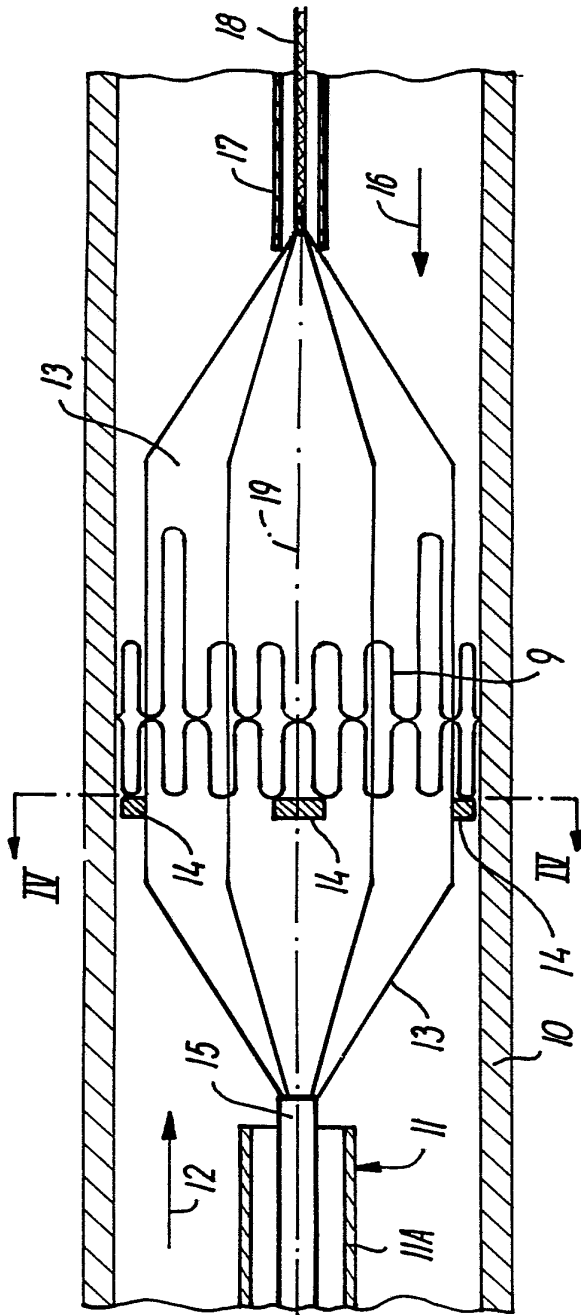


FIG. 3

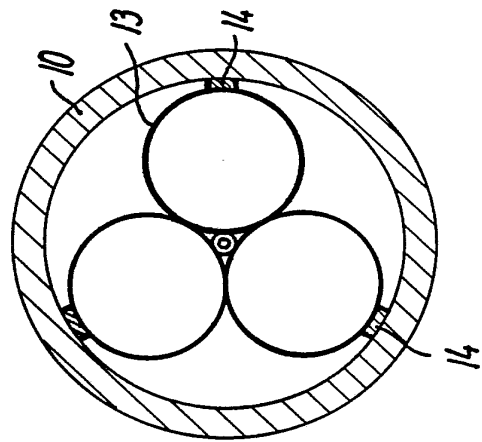


FIG. 4

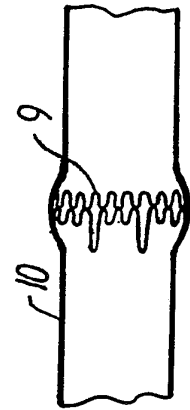


FIG. 7

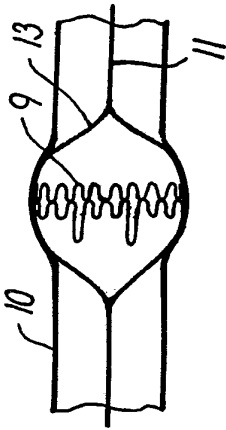


FIG. 6

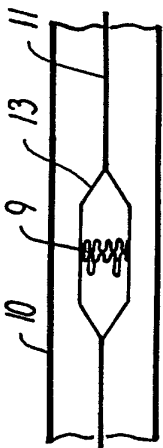


FIG. 5

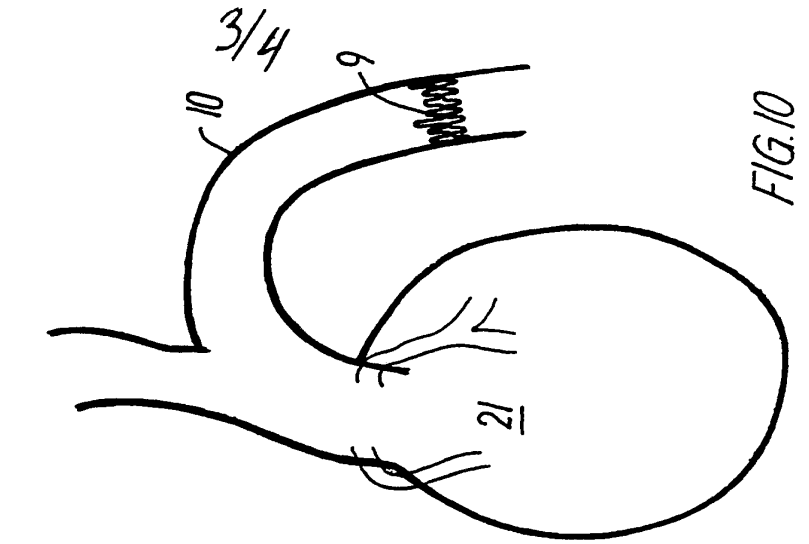


FIG. 10

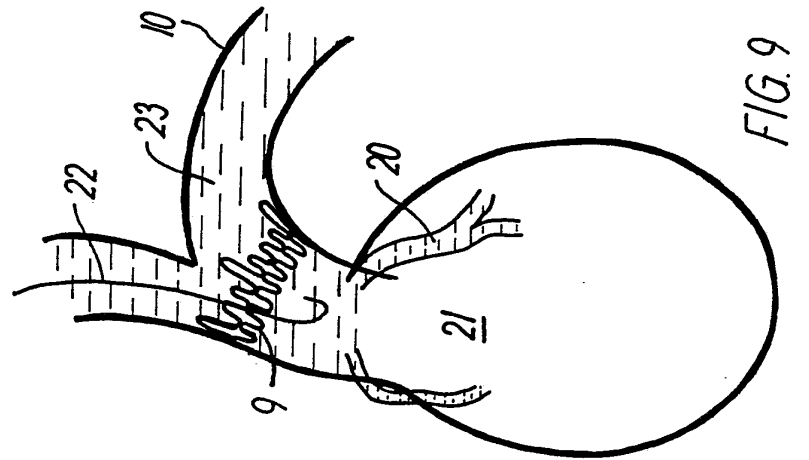


FIG. 9

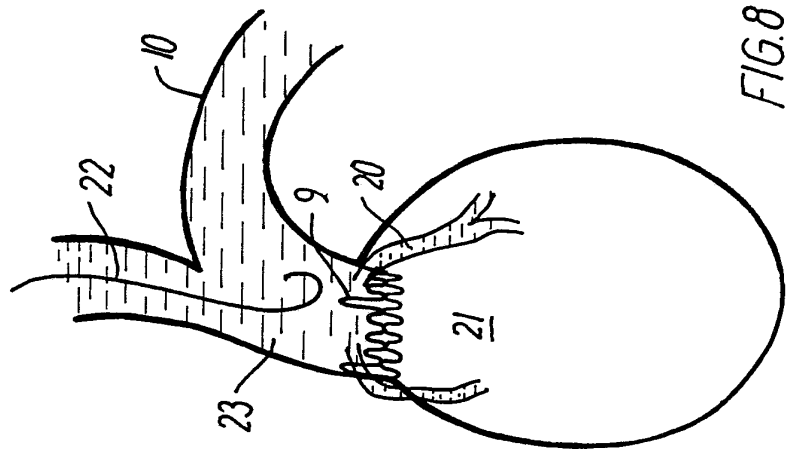
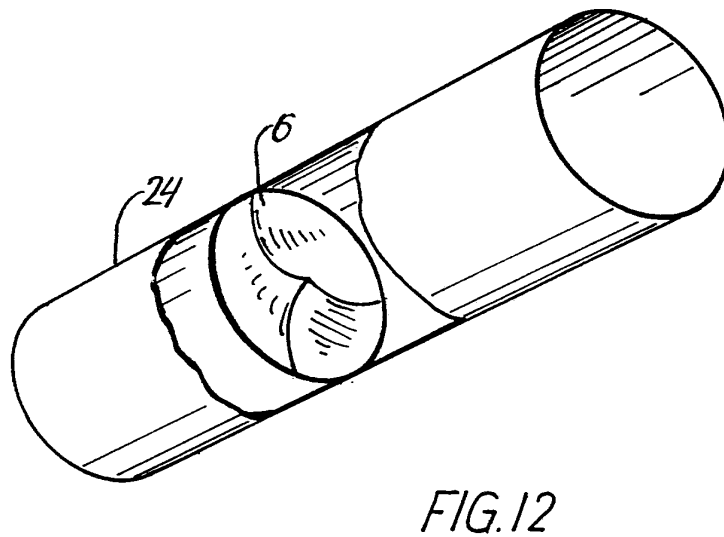
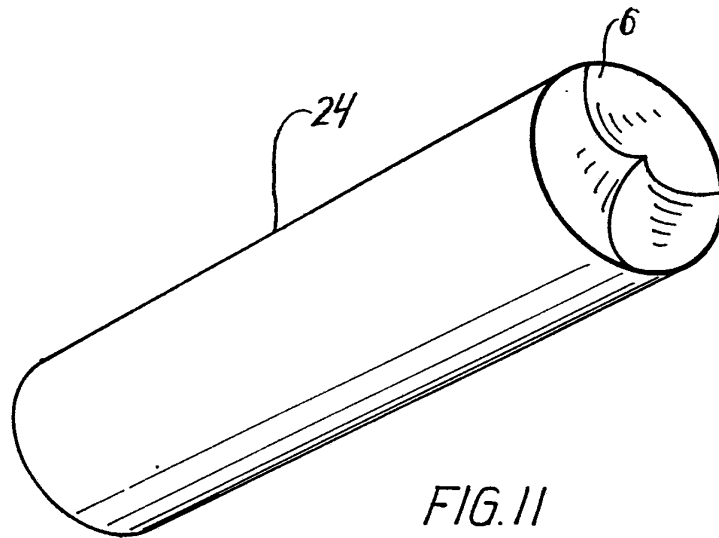


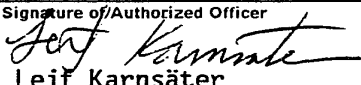
FIG. 8

4/4



## INTERNATIONAL SEARCH REPORT

International Application No PCT/DK 91/00134

<b>I. CLASSIFICATION OF SUBJECT MATTER</b> (if several classification symbols apply, indicate all) <sup>6</sup>		
According to International Patent Classification (IPC) or to both National Classification and IPC		
IPC5: A 61 F 2/24, A 61 M 25/10		
<b>II. FIELDS SEARCHED</b>		
Minimum Documentation Searched <sup>7</sup>		
Classification System	Classification Symbols	
IPC5	A 61 B; A 61 F; A 61 M	
Documentation Searched other than Minimum Documentation to the Extent that such Documents are Included in Fields Searched <sup>8</sup>		
SE,DK,FI,NO classes as above		
<b>III. DOCUMENTS CONSIDERED TO BE RELEVANT<sup>9</sup></b>		
Category *	Citation of Document, <sup>11</sup> with indication, where appropriate, of the relevant passages <sup>12</sup>	Relevant to Claim No. <sup>13</sup>
A	GB, A, 2056023 (DONALD NIXON ROSS) 11 March 1981, see figures 2,3 --	1-5,8
A	US, A, 3671979 (MOULOPOULOS) 27 June 1972, see figures 2B,5 --	1,9
A	Derwent's abstract, No. 87-190 867/27, SU 1 271 508, publ. week 8727 (GORKII KIROV MEDICAL INS) -- -----	1
<p>* Special categories of cited documents:<sup>10</sup></p> <p>"A" document defining the general state of the art which is not considered to be of particular relevance</p> <p>"E" earlier document but published on or after the international filing date</p> <p>"L" document which may throw doubts on priority claim(s) or which is cited to establish the publication date of another citation or other special reason (as specified)</p> <p>"O" document referring to an oral disclosure, use, exhibition or other means</p> <p>"P" document published prior to the international filing date but later than the priority date claimed</p> <p>"T" later document published after the international filing date or priority date and not in conflict with the application but cited to understand the principle or theory underlying the invention</p> <p>"X" document of particular relevance, the claimed invention cannot be considered novel or cannot be considered to involve an inventive step</p> <p>"Y" document of particular relevance, the claimed invention cannot be considered to involve an inventive step when the document is combined with one or more other such documents, such combination being obvious to a person skilled in the art.</p> <p>"&amp;" document member of the same patent family</p>		
<b>IV. CERTIFICATION</b>		
Date of the Actual Completion of the International Search		Date of Mailing of this International Search Report
14th August 1991		1991 -08- 21
International Searching Authority		Signature of Authorized Officer
SWEDISH PATENT OFFICE		 Leif Karnsäter

Form PCT/ISA/210 (second sheet) (January 1985)

FURTHER INFORMATION CONTINUED FROM THE SECOND SHEET		
<p>V. <input type="checkbox"/> OBSERVATIONS WHERE CERTAIN CLAIMS WERE FOUND UNSEARCHABLE <sup>1</sup></p> <p>This international search report has not been established in respect of certain claims under Article 17(2) (a) for the following reasons:</p> <p>1. <input type="checkbox"/> Claim numbers....., because they relate to subject matter not required to be searched by this Authority, namely:</p> <p>2. <input type="checkbox"/> Claim numbers....., because they relate to parts of the international application that do not comply with the prescribed requirements to such an extent that no meaningful international search can be carried out, specifically:</p> <p>3. <input type="checkbox"/> Claim numbers....., because they are dependent claims and are not drafted in accordance with the second and third sentences of PCT Rule 6.4(a).</p>		
<p>VI. <input checked="" type="checkbox"/> OBSERVATIONS WHERE UNITY OF INVENTION IS LACKING <sup>2</sup></p> <p>This International Searching Authority found multiple inventions in this international application as follows:  <b>Claims 1-8 concerning a valve prosthesis.</b>  <b>Claims 9-12 concerning a catheter.</b></p> <p>1. <input type="checkbox"/> As all required additional search fees were timely paid by the applicant, this international search report covers all searchable claims of the international application.</p> <p>2. <input type="checkbox"/> As only some of the required additional search fees were timely paid by the applicant, this international search report covers only those claims of the international application for which fees were paid, specifically claims:</p> <p>3. <input type="checkbox"/> No required additional search fees were timely paid by the applicant. Consequently, this international search report is restricted to the invention first mentioned in the the claims. It is covered by claim numbers:</p> <p>4. <input checked="" type="checkbox"/> As all searchable claims could be searched without effort justifying an additional fee, the International Searching Authority did not invite payment of any additional fee.</p> <p>Remark on Protest</p> <p><input type="checkbox"/> The additional search fees were accompanied by applicant's protest.</p> <p><input type="checkbox"/> No protest accompanied the payment of additional search fees.</p>		

ANNEX TO THE INTERNATIONAL SEARCH REPORT  
ON INTERNATIONAL PATENT APPLICATION NO. PCT/DK 91/00134

This annex lists the patent family members relating to the patent documents cited in the above-mentioned international search report. The members are as contained in the Swedish Patent Office EDP file on 91-06-27. The Swedish Patent Office is in no way liable for these particulars which are merely given for the purpose of information.

Patent document cited in search report	Publication date	Patent family member(s)	Publication date
GB-A- 2056023	81-03-11	US-A- 4343048	82-08-10
US-A- 3671979	72-06-27	NONE	





## INTERNATIONAL APPLICATION PUBLISHED UNDER THE PATENT COOPERATION TREATY (PCT)

<p>(51) International Patent Classification <sup>5</sup> : A61B 17/20, A61M 31/00, 29/00 A61D 1/02</p>	<p>A1</p>	<p>(11) International Publication Number: <b>WO 92/17118</b> (43) International Publication Date: 15 October 1992 (15.10.92)</p>
<p>(21) International Application Number: PCT/US92/02599 (22) International Filing Date: 30 March 1992 (30.03.92) (30) Priority data: 680,705 4 April 1991 (04.04.91) US (71) Applicant: SHTURMAN CARDIOLOGY SYSTEMS, INC. [US/US]; 12000 Marion Lane, Suite 1118, Minneapolis, MN 55343 (US). (72) Inventor: SHTURMAN, Leonid ; 12000 Marion Lane, Suite 1118, Minneapolis, MN 55343 (US). (74) Agents: KAIHOI, Gregory, P. et al.; Fredrikson &amp; Byron, 1100 International Centre, 900 Second Avenue South, Minneapolis, MN 55402 (US).</p>		<p>(81) Designated States: AT (European patent), AU, BE (European patent), CA, CH (European patent), DE (European patent), DK (European patent), ES (European patent), FR (European patent), GB (European patent), GR (European patent), IT (European patent), JP, LU (European patent), MC (European patent), NL (European patent), SE (European patent).</p> <p><b>Published</b> <i>With international search report. Before the expiration of the time limit for amending the claims and to be republished in the event of the receipt of amendments.</i></p>
<p>(54) Title: METHOD AND APPARATUS FOR IN VIVO HEART VALVE DECALCIFICATION</p>		
<p>(57) Abstract</p>		
<p>A method and apparatus for in vivo removal of calcified deposits from an aortic valve. The apparatus includes an anchoring balloon catheter (24) fixatable across the aortic valve, a tool (40) for removing the deposits (15), and attachment means (60) for securing the tool (40) with respect to the anchoring balloon (24) and the aortic valve. The method involves advancing an anchoring balloon catheter (24) through the aorta (10) and positioning it across the aortic valve, inflating the anchoring balloon (24) to fixate it with respect to the aorta (10) and aortic valve, and then operating a deposit removal tool (40) secured to the anchoring balloon (24) to remove the deposits (15).</p>		

**FOR THE PURPOSES OF INFORMATION ONLY**

Codes used to identify States party to the PCT on the front pages of pamphlets publishing international applications under the PCT.

AT	Austria	ES	Spain	MG	Madagascar
AU	Australia	FI	Finland	ML	Mali
BB	Barbados	FR	France	MN	Mongolia
BE	Belgium	GA	Gabon	MR	Mauritania
BF	Burkina Faso	GB	United Kingdom	MW	Malawi
BG	Bulgaria	GN	Guinea	NL	Netherlands
BJ	Benin	GR	Greece	NO	Norway
BR	Brazil	HU	Hungary	PL	Poland
CA	Canada	IT	Italy	RO	Romania
CF	Central African Republic	JP	Japan	RU	Russian Federation
CG	Congo	KP	Democratic People's Republic of Korea	SD	Sudan
CH	Switzerland	KR	Republic of Korea	SE	Sweden
CI	Côte d'Ivoire	LI	Lichtenstein	SN	Senegal
CM	Cameroon	LK	Sri Lanka	SU	Soviet Union
CS	Czechoslovakia	LU	Luxembourg	TD	Chad
DE	Germany	MC	Monaco	TG	Togo
DK	Denmark			US	United States of America

- 1 -

METHOD AND APPARATUS FOR IN VIVO  
HEART VALVE DECALCIFICATION

FIELD OF THE INVENTION

The invention relates to a method and apparatus for removing, in vivo, calcified deposits from heart valves.

BACKGROUND OF THE INVENTION

Calcific aortic stenosis (i.e., the buildup of calcified deposits on the superior surface of the aortic heart valve) accounts for a large percentage of aortic stenosis cases. This condition is characterized by the buildup of calcified nodules on the upper or superior surface of the aortic valve leaflets. These nodules decrease the flexibility of the leaflets, thereby limiting their mobility and capacity to fully open to permit adequate blood flow. Absent anatomic correction, advanced aortic stenosis carries a poor prognosis.

Three techniques have been employed to correct aortic stenosis: valve replacement, intraoperative decalcification (debridement) of the heart valve, and balloon valvuloplasty.

Valve replacement during open heart surgery is currently standard therapy for symptomatic aortic stenosis. Ten year survival rates for isolated aortic valve replacement are generally very good, even in elderly patients. However, this technique requires

- 2 -

that the patient be healthy enough to undergo open heart surgery. The operative mortality for this procedure, particularly among the elderly, is also significant--variously reported at between about 5% and 12%. In addition, a patient receiving a replacement valve typically must take anticoagulation drugs for the rest of his or her life--not all patients are capable of doing this. Moreover, some patients have an aortic root that is not large enough to easily accommodate conventional replacement valves. Thus, there are a significant number of patients for whom valve replacement is either impossible, impractical, or undesirable.

Intraoperative mechanical debridement (decalcification) of the aortic valve to treat aortic stenosis was successfully used for many years prior to the advent of mechanical replacement valves. In this technique, the aorta is entered surgically (as in a valve replacement procedure) but rather than replace the valve the surgeon manually removes the calcified deposits, using suitable surgical tools. The debridement techniques, although for some time completely forsaken in favor of valve replacement procedures, has enjoyed some recent revival, particularly for patients having a small aortic root and/or contraindications for anticoagulation therapy. In addition to mechanical tools, recently ultrasonic debridement has also been demonstrated to be effective to remove calcific deposits. Nevertheless, these techniques still require the patient to be healthy enough to survive and recuperate from thoracic surgery, and involve all of the costs and risks attendant with such surgery.

The third technique for correcting aortic stenosis involves percutaneous balloon aortic

- 3 -

valvuloplasty (BAV). In this procedure, an inflatable balloon catheter is advanced to the aortic valve and inflated to compress and fracture the calcified nodules in an attempt to increase leaflet mobility. Although this procedure eliminates many of the risks and disadvantages attendant with the preceding two techniques, restenosis is very common within one year, limiting the technique's usefulness to temporarily mitigating symptoms for those patients who are poor surgical candidates or refuse surgery.

#### SUMMARY OF THE INVENTION

The invention provides a method and apparatus for in vivo removal of calcified deposits from an aortic valve. The apparatus includes an anchoring balloon catheter fixatable across the aortic valve, a tool for removing the deposits, and attachment means for securing the tool with respect to the anchoring balloon and the aortic valve.

The attachment means preferably includes means for positioning the deposit removal tool with respect to the anchoring balloon. In one embodiment the distal end of a guiding catheter is secured to the anchoring balloon, and positioning of the tool is accomplished by selectively moving the distal end of the guiding catheter about the anchoring balloon and by moving the tool around within the guiding catheter.

One embodiment for securing the guiding catheter with respect to the anchoring balloon while allowing selective movement of the guiding catheter employs a circumferential band having first and second ends respectively attached to the anchoring balloon, with the distal end of the guiding catheter attached to an intermediate portion of the band. Positioning balloons are interposed between the circumferential band and the anchoring balloon. The positioning

- 4 -

balloons work in concert, so that as one balloon is inflated, the other is deflated, thereby changing the relative position of the intermediate portion of the band and the associated distal end of the guiding catheter. Thus, when a first of the balloons is being inflated (with the second balloon being simultaneously deflated), the distal end of the guiding catheter will move clockwise about the anchoring balloon, and when the second balloon is being inflated (with the first balloon being simultaneously deflated), the distal end of the guiding catheter will move counterclockwise about the anchoring balloon.

The deposit removal tool may be positioned within the guiding catheter by providing a coaxial positioning catheter within the guiding catheter. The positioning catheter preferably includes an off-center lumen in which the elongated shaft of the removal tool is closely received. Thus, by rotating the positioning catheter within the guiding catheter, the position of the removal tool can be selectively controlled.

The removal tool may comprise any effective device, including any one of a variety of rotatable cutting, scraping or abrading devices, an ultrasonic vibrations generator or a wire capable of conveying ultrasonic vibrations and being connected to an ultrasonic vibrations generator, an optical fiber connected to a laser outside of the body, a pair of electrodes connected to a high voltage source outside of the body, or any other suitable device.

In a modified embodiment of the invention, the anchoring balloon catheter utilized in the invention comprises an inflatable tube that has a proximal, generally straight portion, and a distal, helically coiled portion. The turns of the helical coil may be

- 5 -

spaced from one another slightly, or successive turns may abut one another. Means may also be provided for securing the turns of the coil to one another, such as by providing an outer or inner skin to which the turns adhere.

The method of the invention involves removing, in vivo, deposits from an aortic valve's superior surface. The method comprises the steps of advancing an anchoring balloon catheter through the aorta and positioning it across the aortic valve, inflating the anchoring balloon to fixate it with respect to the aorta and aortic valve, and then operating a deposit removal tool secured to the anchoring balloon to remove the deposits.

#### BRIEF DESCRIPTION OF THE DRAWINGS

Figure 1 is a perspective view in partial cross-section of the apparatus of the invention fixated in the aortic valve of a heart;

Figure 2 is a perspective view in partial cross-section similar to Figure 1 with one of the valve leaflets removed for clarity and with the guiding catheter shown in a moved position;

Figure 3 is a cross-section of Figure 1 taken along line 3-3 thereof;

Figure 4 is a cross-sectional view similar to Figure 3 shown in a moved position;

Figure 5 is another cross-sectional view similar to Figure 3 showing a second moved position;

Figure 6 is a cross-sectional broken-away view of a modified embodiment of the invention;

Figure 7 is a cross-sectional view of Figure 6 taken along line 7-7 thereof;

Figure 8 is a cross-sectional view of Figure 6 taken along line 8-8 thereof;

Figure 9 is a somewhat schematic representation

of another embodiment of the apparatus of the invention in the process of being introduced into a patient;

Figure 9A is a cross-sectional view of Figure 9, taken along line 9A-9A thereof;

Figure 10 is a view similar to Figure 9 after the guiding catheter has been introduced into the otherwise flaccid sheath;

Figures 10A and 10B are cross-sectional views of Figure 10, taken respectively across lines 10A-10A and 10B-10B thereof;

Figure 11 is a view similar to Figure 9 after the tool has been introduced into the guiding catheter;

Figures 11A, 11B and 11C are cross-sectional views of Figure 11, taken respectively across lines 11A-11A, 11B-11B and 11C-11C thereof;

Figure 12 is a view similar to Figure 9 after the positioning catheter has been introduced into the guiding catheter over the tool shaft;

Figure 12A is a cross-sectional view of Figure 12, taken across line 12A-12A thereof;

Figure 13 is a perspective view of another modified embodiment of the invention;

Figure 13A is a cross-sectional view, partially broken away, of Figure 13 taken along line 13A-13A thereof;

Figure 13B is a cross-sectional view similar to Figure 13A shown in a moved position;

Figure 14 is a cross-sectional view similar to Figure 13B showing a modified embodiment of the invention;

Figure 15 is a modified embodiment of the invention;

Figure 15A is a cross-sectional view of Figure 15, taken along line 15A-15A thereof;



- 7 -

Figure 16 is yet another modified embodiment of the invention;

Figure 16A is a view of the other side of the embodiment shown in Figure 16;

Figure 17 is a perspective view of yet another embodiment of the invention;

Figure 18 is a perspective, partially broken-away view of a yet one more embodiment of the invention;

Figure 19 is a schematic illustration of a cardiopulmonary support/bypass system utilized in conjunction with the decalcification apparatus of the invention;

Figure 20 shows a modified arrangement of the cardiopulmonary support system of Figure 19;

Figure 21 shows a modified arrangement of the cardiopulmonary support system of Figure 19;

Figure 22 shows a modified arrangement of the cardiopulmonary support system of Figure 19;

Figure 23 shows a modified arrangement of the cardiopulmonary support system of Figure 19;

Figure 24 is a cross-sectional view of an anchoring balloon of the invention;

Figure 25 is a cross-sectional view of a modified embodiment of the anchoring balloon of the invention;

Figure 26 is a cross-sectional view of another modified embodiment of an anchoring balloon of the invention;

Figure 26A is a cross-sectional view of Figure 26, taken along line 26A-26A thereof;

Figure 27A is a perspective, broken-away view in partial cross-section showing yet another embodiment of the apparatus of the invention;

Figure 27B shows the distal ends of the various

- 8 -

catheters utilized in the embodiment of Figure 27A;

Figure 28 shows a modified version of the embodiment of Figure 27A;

Figure 29 shows the embodiment of Figure 27A inserted into position prior to inflation of the anchoring balloon;

Figure 30 shows an alternate embodiment, partially broken away, similar to Figure 29;

Figure 31 shows another modified embodiment of the invention;

Figures 32A and 32B show yet another modified embodiment of the invention; and

Figures 33-35 show alternate deposit removal tools usable with the apparatus of the invention.

BEST MODE FOR CARRYING OUT THE INVENTION

Figure 1 shows in perspective, partial cross-sectional view an anchoring balloon catheter 24 of the invention secured in the aorta 10, with its distal portion 25 inserted past the leaflets 12 of the aortic valve. In Figure 2, a portion of the valve leaflets 12 in the foreground has been omitted to reveal better the position and shape of the distal portion 25 of the anchoring balloon catheter 24 and the deposits 15 on the superior surface 13 of the leaflets. In this view, it can be seen that the distal portion 25 of the anchoring balloon is preferably of a larger diameter, having a shoulder 26 that contacts the inferior surface of the valve leaflets 12 to accurately and securely position the anchoring balloon 24, with respect to the valve leaflets 12, providing support to the leaflets to stabilize their positions and to outline the inferior surface of the leaflets 12 in contact with the balloon inflated with radiographic contrast solution. The anchoring balloon catheter 24 also includes a central

- 9 -

catheter 21 having preferably at least a pair of lumens, one 22 for passage of the anchoring balloon catheter 24 over a guide wire (not shown) and/or injection or withdrawal of fluids therethrough, and a second 23 for inflation of the balloon 24.

Attachment means is provided to secure a deposit removal tool 40 to the inflatable anchoring balloon catheter 24. The attachment means may comprise a variety of configurations. A preferred embodiment is depicted in Figures 1-5. In this embodiment, the attachment means includes means for selectively positioning the deposit removal tool 40 with respect to the anchoring balloon 24 so that the physician can guide the tool 40 carefully to the calcification deposit 15 which is to be removed. Again, the preferred embodiment illustrated in Figures 1-5 shows a preferred mechanism for achieving this selective control.

In this preferred embodiment, a circumferential band 60 having first and second ends 62 and 64, respectively, is attached to the anchoring balloon 24. The circumferential band 60 also includes an intermediate portion 66, which is attached to a guiding catheter 42. The deposit removal tool 40 in turn is disposed within the guiding catheter 42.

As mentioned above, preferably means is provided for selectively moving the guiding catheter 42 about the periphery of the anchoring balloon 24. In this preferred embodiment, a pair of positioning balloons 70 and 76 are disposed between the circumferential band 60 and the anchoring balloon 24, each located adjacent the ends 62 and 64 of the circumferential band 60. As illustrated in Figures 3-5, the guiding catheter 42 can be moved about the periphery of the anchoring balloon 24 by selectively inflating and

- 10 -

deflating the positioning balloons 70 and 76.

In Figure 3, both of the positioning balloons 70 and 76 are partially inflated, and the guiding catheter 42 is in a generally central position. In Figure 4, one of the positioning balloons 70 has been fully inflated and the other positioning balloon 76 deflated, causing the guiding catheter 42 to have moved to its most clockwise location. In Figure 5, the first positioning balloon 70 is fully deflated, and the second positioning balloon 76 is fully inflated, causing the circumferential band 60 to pull the guiding catheter 42 to its most counterclockwise position. Thus, by selectively inflating and deflating the positioning balloons 70 and 76, the guiding catheter 42 can be moved through a range of positions about the anchoring balloon 24. The size of the positioning balloons and the diameter of the anchoring balloon will dictate what total range of motion is possible. Preferably, the range of motion should be at least about 120°, allowing the deposit removal tool 40 to fully service one of the three leaflets 12 of the aortic valve without repositioning the anchoring balloon 24. To remove deposits from the other leaflets 12, the anchoring balloon 24 can be partially deflated and then rotated to a new position corresponding to one of the other leaflets 12.

Figures 3-8 depict a secondary positioning means that allows some control over the radial position of the deposit removal tool 40. In this embodiment, a positioning catheter 46 is disposed within the guiding catheter 42. The positioning catheter 46 includes an off-center lumen 49 in which the shaft 41 of the deposit removal tool 40 is carried. By rotating the positioning catheter 46 with respect to the guiding catheter 42, the deposit removal tool 40 can be

- 11 -

adjusted radially inwardly and outwardly with respect to the anchoring balloon 24. Some limited control over the circumferential position of the tool 40 is also provided.

Figures 6-8 illustrate a particularly preferred embodiment in which the positioning catheter 46 includes indexing slots 47 at its distal end. The guiding catheter 42 in turn carries a tab 43 extending radially inwardly (the tab 43 may, e.g., extend radially inwardly from a metal ring 45 carried by the guiding catheter 42). As the positioning catheter 46 is advanced through the guiding catheter 42 to its most distal position, the tab 43 of guiding catheter 42 will engage a corresponding slot 47 in the positioning catheter 46. This prevents rotational movement of the positioning catheter 46 with respect to the guiding catheter as the tool is being utilized. Where it is desired to change the rotational position of the positioning catheter 46, it can be withdrawn slightly, rotated, and then again advanced to engage the tab 43 in the desired slot 47 corresponding to the desired position.

Figures 9-12 illustrate another modification of the invention which includes a collapsible sheath 44, and illustrate its use in the process of introducing the device of the invention into the patient. In Figure 9, the aorta 10 is shown schematically dividing into the left and right iliac arteries 11. The anchoring balloon catheter 24 with its catheter 21 has been inserted into the iliac artery 11, and advanced through the aorta to the aortic valve, where the anchoring balloon 24 is inflated. In this embodiment, a flaccid sheath 44 is connected directly to the circumferential band 60. This flaccid sheath allows final assembly of the entire unit inside the

- 12 -

body--i.e., the anchoring balloon with the flaccid sheath 44, the circumferential band 60 and the positioning balloons 70 and 76 (all deflated and furled about the catheter 21 of the anchoring balloon 24) can first be inserted into the aorta 10 via the iliac artery 11. The guiding catheter, positioning catheter and deposit removal tool can then be inserted, after the anchoring balloon catheter is in position. The flaccid nature of this sheath 44 therefore allows the deflated anchoring balloon 24 with attachment means to be furled into a relatively small diameter unit for insertion through the narrower iliac artery 11 into the wider aorta 10. Once the anchoring balloon 24 has entered the aorta 10 (and, preferably, reached its position in the aortic valve), the anchoring balloon 24 can be inflated and the rest of the unit assembled by inserting the guiding catheter 42 through the sheath 44 to its position adjacent the anchoring balloon 24, followed by the deposit removal tool and the positioning catheter. To ease insertion of the guiding catheter into the sheath 44, the sheath can be of a larger diameter proximally, narrowing at its most distal portion to a diameter that closely receives the guiding catheter therein.

In Figure 9, the guiding catheter 42 has been advanced only slightly into the sheath 44. In Figure 10, the guiding catheter 42 is fully advanced, and the deposit removal tool 40 is about to be introduced. Note that Figures 10A and 10B illustrate the cross-sectional configuration of the device, and show catheter 19 with four lumens--one each 71 and 77 for inflating and deflating the positioning balloons 70 and 76, one 23 for inflating the anchoring balloon itself, and one 22 for passing through a guide wire or injecting or withdrawing fluids such as contrast or

- 13 -

blood. The catheter 19 is formed from catheter 21 of the anchoring balloon catheter 24 and catheters 72 and 78 of the positioning balloons 70 and 76, respectively.

In Figure 11 the deposit removal tool 40 has been fully advanced through the guiding catheter 42 and the positioning catheter 46 is about to be advanced over the shaft 41 of the deposit removal tool 40. Figure 11A depicts the tool's shaft 41 closely received in the off-center lumen 49 of the positioning catheter 46. Figure 12 shows the positioning catheter 46 fully advanced through the guiding catheter 42. A "Y" connector 52 may be provided on the proximal end of the positioning catheter 46 to allow fluid to be injected or withdrawn through the main lumen 50 of the positioning catheter 46, while the elongated shaft 41 of the tool 40 exits through a sealing fitting 51. In most applications, the main lumen 50 will be utilized to withdraw fluid from the area immediately adjacent the deposit removal tool, thereby removing any particles or debris cut away by the tool. This lumen 50 may also be used, however, for injecting fluids, such as contrast solutions used in radiographic imaging.

Figures 13-14 depict an alternate embodiment for providing attachment means to secure the tool 40 with respect to the anchoring balloon 24 and for permitting selected positioning of the deposit removal tool 40 with respect to the anchoring balloon 24. In this embodiment, a set of circumferential straps is provided. In the embodiment illustrated, a set of upper and lower circumferential straps 85 is attached with a first end 86 secured to the anchoring balloon 24 and a second end 87 attached to the guiding catheter 42. A middle strap 90 similarly has a first

- 14 -

end 91 attached to the anchoring balloon 24 and a second end 92 attached to the guiding catheter 42. The middle strap 90 is wound about the anchoring balloon 24 in a direction opposite that of the upper and lower straps 85. The guiding catheter 42 may then be rotated to move it circumferentially about the anchoring balloon 24. Referring to Figures 13A-13B, as the guiding catheter is rotated clockwise, the middle strap 90 will wind up on the guiding catheter 42, while the upper and lower straps 85 will unwind from the guiding catheter 42; as this occurs, the guiding catheter 42 will move clockwise about the anchoring balloon 24 from the position illustrated in Figure 13A to the position illustrated in Figure 13B. Figure 14 shows a slightly modified arrangement of this embodiment where the straps 85 and 90 are somewhat longer, permitting movement of the guiding catheter 42 substantially entirely around the anchoring balloon 24.

Figures 15 and 15A show another simplified embodiment of the invention. In this embodiment guiding catheter 42 is attached directly to the wall of the anchoring balloon 24. Positioning of the tool is accomplished merely by rotating the anchoring balloon 24 itself with respect to the aortic valve, and by rotating the positioning catheter 46 within the guiding catheter 42.

Figures 16-16A show yet another embodiment for controllably positioning the guiding catheter with respect to the anchoring balloon (Figure 16A showing the back side of Figure 16). In this embodiment a pair of cords 57 can be manipulated to move the guiding catheter 42 about the periphery of the anchoring balloon 24. Each cord 57 is attached at its distal end 57a to a pulley strip 59 that in turn is



- 15 -

attached to the anchoring balloon (Figure 16A). The cord is then threaded through a series of pulleys on a pair of pulley rings 58 carried by the guiding catheter 42 and pulleys on the fixed pulley strip 59. By pulling on one of the cords 57 while releasing the other the guiding catheter will be pulled around the anchoring balloon in one direction; by pulling on the other cord, the guiding catheter will be pulled around in the other direction.

In practice, the decalcification procedure of the invention proceeds as follows. Access to the aorta 10 is obtained, typically through percutaneous or cut-down entry into the femoral artery with a guide wire. The guide wire is advanced through the femoral and iliac arteries and the aorta to the aortic valve and then across the aortic valve into the left ventricle (L.V.). A deflated anchoring balloon catheter 24 is then advanced over the guide wire to a position across the aortic valve with the distal tip of the balloon in the left ventricle (L.V.). The anchoring balloon 24 is then inflated and slightly retracted to engage the shoulder 26 of the anchoring balloon 24 against the inferior surface of the calcified valve leaflets 12. (Depending on the situation and the type of anchoring balloon catheter utilized, cardiopulmonary support/bypass may be necessary once the balloon is inflated, and this can be accomplished as described below.)

When utilizing the embodiment having the collapsible guiding catheter sheath 44 attached to the anchoring balloon 24, the guiding catheter 42 may then be advanced through the sheath 44 to proper position adjacent the anchoring balloon 24. The deposit removal tool 40, together with the positioning catheter 46, may then be advanced through the guiding

- 16 -

catheter 42 to their proper positions. One or both of the positioning balloons 70, 76, may then be inflated to circumferentially locate the guiding catheter 42 and, hence, the deposit removal tool 40 as desired. The positioning catheter may also be rotated to further position the removal tool 40. The tool 40 in turn may also be slightly advanced or withdrawn as necessary. Operation of the removal tool 40 can then be commenced, with blood and dislodged calcification deposits being sucked up through the main lumen 50 of the positioning catheter 46. When deposits from a particular leaflet 12 have been removed, the anchoring balloon 24 can be deflated partially and rotated to position the removal tool 40 adjacent one of the other leaflets 12. When the calcification deposits have been removed, the entire device may be removed essentially by reversing the process of inserting the device.

During the procedure, conventional radiographic imaging techniques may be utilized to allow the physician to view the relative locations of the anchoring balloon 24, deposit removal tool 40, and the calcified deposits which are to be removed from the aortic valve leaflets. Preferably, the components of the anchoring balloon and removal tool and associated catheters are either radio-opaque or marked with radio-opaque markers so that they will be visible by conventional radiographic imaging techniques. Visualization of the anchoring balloon and positioning balloons and the inferior surface of the leaflets in contact with the anchoring balloon 24 is further facilitated by using radiographic contrast solution for inflation of the balloons 24, 70 and 76. Contrast may also be injected either through the lumen 22 of the anchoring balloon 24, or through the main lumen 50

- 17 -

of the positioning catheter 46.

In addition, known ultrasound imaging techniques may also be utilized. N. Bom and J. Roelandt have edited a reference book entitled "Intravascular Ultrasound," (Kluwer Academic Publishers 1989), containing a variety of articles detailing techniques, developments, and clinical perspectives on intravascular ultrasound procedures. Figure 17 illustrates one possible embodiment utilizing a phased array ultrasound transducer 29 (containing many small acoustic elements 128) mounted on the catheter 21 of the anchoring balloon 24. This transducer 29 will generate a cross-sectional view of the aortic valve and the location of the calcified deposits to be removed. The details of such ultrasound techniques for intravascular imaging are well-known, as described in the above-mentioned text. Ultrasound preferably is used in conjunction with and not to the exclusion of conventional radiographic imaging.

Figure 18 shows another embodiment of the invention where an ultrasound catheter 132 is positioned inside one of the lumens of the catheter 21 of the anchoring balloon 24, preferably the lumen 22. The ultrasound catheter 132 shown in Figure 18 operates on a principle different from the one shown in Figure 17. Instead of a phased array transducer, the ultrasound catheter 132 includes an echo transducer 133 and a mirror 31 rotated by a flexible shaft 30. This embodiment is advantageous in that it allows the ultrasound catheter 132 to be advanced or retracted in the lumen 22 of the anchoring balloon 24 to provide a cross-sectional image at the desired more distal or more proximal position. As these types of ultrasound catheters and procedures are described in greater detail in the Bom reference identified above,

- 18 -

further description is not necessary here.

During performance of the decalcification procedure, it is desirable to provide cardiopulmonary support/bypass for the patient, as an anchoring balloon 24 of the type depicted in Figure 1 substantially occludes the aortic valve. Figures 19-23 depict several variations for providing such support.

Figure 19 depicts in schematic form a first variation. Blood is ejected/withdrawn from the left ventricle through the central lumen 22 of the anchoring balloon catheter 24 and delivered to a first pump 106. That pump 106 in turn delivers the blood through a filter 107 to a heat exchanger 108 and then through percutaneous catheter 111 back to the iliac artery 11 and the aorta 10. Blood and calcification deposit debris loosened by the removal tool 40 are aspirated into the main lumen 50 of the positioning catheter containing the tool shaft by a second pump 110. Debris is filtered out by a second filter 109, after which the blood is sent through the heat exchanger 108 and the return catheter 111 back to the aorta 10.

To assure adequate extracorporeal circulation an additional blood withdrawal catheter 113 is percutaneously introduced into the iliac vein 120. Blood withdrawn through this catheter 113 should be oxygenated before being returned to the body. This may be accomplished by a conventional oxygenator 105 which in turn passes the blood through pump 106 to filter 107, and heat exchanger 108, whereupon the blood may be returned to the aorta 10 through the return catheter 111.

In order to maintain blood flow through the heart sufficient to significantly reduce the risk of

- 19 -

cardiac asystole, particularly in light of the relatively small size of the central lumen 22 of the anchoring balloon catheter 24, a supplemental catheter 112 may be advanced percutaneously through the vena cava 100 to the left ventricle (L.V.) by way of the right atrium (R.A.) and the left atrium (L.A.), as shown in Figure 20. To achieve this positioning of the catheter 112, the catheter must pass through the thin septum between the right atrium (R.A.) and left atrium (L.A.), such as is commonly done in mitral balloon valvuloplasty (see, e.g., T. Bashore, "Invasive Cardiology Principles and Techniques" (B.C. Decker Inc.) at pp. 147ff). This catheter 112 may be of substantial diameter in comparison to the central lumen 22 of the anchoring balloon catheter 24. Blood ejected/withdrawn through this catheter 112 passes from pump 106 through filter 107 to heat exchanger 108 and then through the return catheter 111 back to the aorta 10. Catheters 112 and 113 may be arranged in a double lumen catheter, which may be a side by side double lumen, a coaxial double lumen, or even a single lumen catheter that has holes in a wall thereof in an intermediate portion, defining the distal "end" of the vein access catheter 113.

The foregoing blood paths through the lumen 22 of the anchoring catheter 24 and through catheter 112 usually will allow sufficient cardiac output to prevent cardiac asystole.

Figure 21 depicts an alternate arrangement for external blood flow. In this configuration, the blood withdrawn from the left ventricle of the heart (through the larger catheter 112 and through the central lumen 22 of the anchoring balloon catheter 24) is passed directly to the oxygenator 105 before being returned (via pump 106, filter 107 and heat exchanger

- 20 -

108) to the aorta 10 through return catheter 111. In yet another configuration shown in Figure 22, all of the blood withdrawn from the heart is first passed through pump 110 and the second filter 109 before being sent to the oxygenator 105.

In yet a further embodiment shown in Figure 23, an additional pump 114 is provided upstream from the oxygenator but separate from the second pump 110, thereby permitting separate control of the blood withdrawn by the main lumen 50 of the catheter containing the deposit removal tool. Other equivalent arrangements may also be utilized. The arrangements depicted in Figures 19-23 demonstrate, however, that cardiac function and coronary circulation can be maintained even while the decalcification procedure is being performed. Rapid cardiac pacing at about 180-200 beats per minute also may be employed to lower cardiac output, particularly when the trans-septal approach to the left ventricle (L.V.) is not used.

Figures 24-26A depict possible configurations for the anchoring balloon of the invention. Figure 24 shows in cross section the anchoring balloon depicted in Figure 1 and many of the other figures. The balloon includes a distal portion 25 that is of a larger diameter than the rest of the balloon, thereby providing a shoulder 26 for engaging and supporting the inferior surface of the valve leaflets 12--the balloon is inserted past the leaflets 12 and then inflated as it is withdrawn to allow the shoulder 26 to seat against the inferior surface of the valve leaflets 12.

In Figure 25 the anchoring balloon 24 includes an enhanced shoulder 26 formed by constructing a distal chamber 27 which is in fluid communication with the main chamber 28. The enhanced shoulder 26

- 21 -

provides an even more secure engagement against the inferior surface of the valve leaflets 12. Figure 26 shows a modified version of the balloon of Figure 25 wherein the main chamber is merged with the distal chamber, but the enhanced shoulder 26 is preserved. Figure 26A shows a cross-section of the anchoring balloon catheter 24 with the catheter 21 having two lumens, the lumen 22 through which a guide wire may be advanced or withdrawn and through which fluid may be withdrawn or injected, and the lumen 23 which communicates with the interior of the balloon to inflate and deflate it. Any of the embodiments of Figures 24-26A can be modified so that the shoulder portion is manufactured from a thin layer of stretchable material (such as silicone) and the remaining portion of the balloon from a substantially non-stretchable material (or a stretchable material that is reinforced so that it will not stretch beyond a certain point). With this construction, the balloon can be controllably inflated so that the thin, stretchable shoulder portion 26, which engages and supports the leaflets 12 of the aortic valve, will conform very closely to the shape of the leaflet, giving close, uniform support to the leaflet.

Figures 27A-30 depict an alternate embodiment of the invention that may partially or entirely eliminate the need for the cardiopulmonary support/bypass system depicted in Figures 19-23. In this embodiment, the anchoring balloon 24' consists of an inflatable tube 32 coiled into a helical configuration and held in this helical configuration by an inner sheath or skin 33, defining a large bore lumen 34. The helical anchoring balloon 24' allows its large bore lumen 34 to present a substantially open passageway distally and proximally, allowing blood to continue flowing through

- 22 -

the balloon even when it is inflated and holding the valve leaflets 12 in position for the decalcification procedure. If desired, a rotating screw-type pump 35 may be secured in the proximal portion of the balloon to maintain circulation through the aorta 10 while the procedure is being performed. Such screw-type pumps are well known, such as the HEMOPUMP® brand pump available through Johnson & Johnson. (Figure 28 shows that multiple screw pumps may be used in parallel to increase the volume of blood pumped. Figure 28 also shows that one of the screw pumps--e.g., the proximal one--may be used to pump blood from the main lumen 50 of the positioning catheter through the filter 124 at the proximal end of such screw pump.)

A catheter 39 (Figure 27A) is disposed in the central portion of the distal end of the helical anchoring balloon 24'. The catheter 39 is carrying the phased array ultrasound transducers 29, described previously. The ultrasound catheter 39 desirably exits the large bore lumen 34 through the skin 33 intermediate of the position of the screw pump 35 and the distal end of the helical anchoring balloon 24'. To allow assembly of the catheter into the helical anchoring balloon 24' after insertion of the balloon into the patient, a flaccid sheath 39a may be attached to the skin 33 at the point of entry of the catheter into the large bore lumen 34. Thus, the deflated, furled balloon may be first inserted; once in position, it can be inflated, and the catheter 39 can then be inserted through the flaccid sheath 139 to its position as shown in Figure 27A. A guide wire 136 may also be advanced via the flaccid sheath 139 or via the lumen of the catheter 39 as necessary.

Figure 27B shows the proximal end of the various catheters and lumens attached to the configuration in



- 23 -

Figure 27A, including the catheter 39 (containing leads for the ultrasound transducer 29), the drive shaft 139 for the screw pump 35, a syringe (or similar inflation device) 80 with catheter 23 for inflating the anchoring balloon, inflation devices 73 and 79, respectively, for the first and second positioning balloons, a blood pump 110 for withdrawing blood through the main lumen 50 of the positioning catheter 46, a blood filter 109 and a return catheter 111 to return filtered blood back to an artery (usually the aorta).

Figure 29 depicts the configuration of the device shown in Figure 27A and B immediately after it has been advanced over the guide wire 136, but prior to being inflated/unfurled. In Figure 29, the helical anchoring balloon 24' is in a deflated, furled configuration (the view shows in partial cross-section the layers of helical tubes 32 furled upon one another). A release string 55 may be provided to maintain the distal end of the device in a furled configuration; when the string is withdrawn, it releases the balloon to be inflated. Figure 30 shows a modified embodiment where a release strap 56 is adhesively attached to the distal portion of the furled helical anchoring balloon 24' (rather than the string 55) to keep it in furled configuration. When the strap is withdrawn, it similarly releases the balloon to be inflated.

Figure 31 depicts yet another embodiment of the invention that facilitates blood flow through the helical anchoring balloon catheter 24' while the procedure is being performed. A series of check valve flaps 81, covering orifices 82 in the skin 33 of the anchoring balloon, is provided proximally of the aortic valve to permit blood to flow outwardly through

- 24 -

such orifices 82 into the aorta during systole. During diastole, the valve flaps 81 close, similarly to the function of the aortic valve itself, to prevent reflux of the blood into the left ventricle. (Check valves of this type would also be usable with the anchoring balloon catheter 24 of Figure 1.) Figures 32A and 32B show alternate embodiments wherein the helical anchoring balloon 24' in its proximal portion includes a preferably trileaflet valve 83 similar in shape and function to the natural aortic valve.

Although most of the figures depict the deposit removal tool as being a conventional rotatable burr or similar cutting or abrasive device, any other suitable tool may also be employed. Figures 33-35 depict three other possibilities. In Figure 33, a laser 140 (preferably located external to the patient) is connected to a fiber-optic strand 141 which has a distal end positionable adjacent the calcified deposits to be removed. In Figure 34, an ultrasonic vibration generator 144 (e.g., of the type that generates vibrations in the range of 20,000 Hz) is connected to a wire 145 having a distal tip positionable adjacent the calcified deposits, the wire 145 being capable conveying ultrasonic vibrations. In Figure 35 a high voltage source 147 is connected to a pair of electrically conductive wires 148 having distal tips positionable adjacent the calcified deposits for generating an arc to destroy the deposits. Tools of other suitable configurations may similarly be utilized.

The components of the anchoring balloon catheter 24 of the invention may be manufactured from any suitable materials, including conventional plastics, silicones, etc. that are biocompatible and possess the desired flexibility/rigidity properties, as the case

- 25 -

may be, to perform the desired functions. Such materials are well known, being utilized commonly in current balloon catheters and other intravascular devices. The helical balloon of the invention may be manufactured by any suitable techniques, such as by winding tube 32 into a coiled configuration (as by winding it upon a mandrel) and then securing the turns by either applying an outer skin (or an inner skin, if desired). Such a skin may be formed by applying a thin layer of adhesive, by securing a thin layer of flexible plastic, or by any other suitable means.

While a preferred embodiment of the present invention has been described, it should be understood that various changes, adaptations and modifications may be made therein without departing from the spirit of the invention and the scope of the appended claims.

- 26 -

## WHAT IS CLAIMED IS:

1. Apparatus for in vivo removal of deposits from an aortic heart valve, comprising:  
an anchoring balloon catheter fixatable across the aortic valve;  
a deposit removal tool; and  
attachment means for securing the tool with respect to the anchoring balloon and the aortic valve.
2. The apparatus of claim 1 wherein the attachment means includes positioning means for adjustably positioning the deposit removal tool with respect to the anchoring balloon.
3. The apparatus of claim 1 further comprising a guiding catheter through which the deposit removal tool may be advanced toward the aortic valve, the guiding catheter including a distal end portion secured to the anchoring balloon catheter by the attachment means.
4. The apparatus of claim 3 wherein the attachment means comprises a circumferential band having first and second ends respectively attached to the anchoring balloon, and an intermediate portion operatively connected to the guiding catheter.
5. The apparatus of claim 4 wherein the attachment means further includes positioning balloon means for selectively moving the guiding catheter about the anchoring balloon in response to inflation and deflation of the positioning balloon means.
6. The apparatus of claim 5 wherein the positioning balloon means comprises two positioning balloons interposed between the circumferential band and the anchoring balloon.
7. The apparatus of claim 6 wherein each positioning balloon is located adjacent an end of the circumferential band.

8. The apparatus of claim 6 wherein the positioning means includes means for selectively inflating and deflating the positioning balloons whereby the guiding catheter will move clockwise about the anchoring balloon when one of the positioning balloons is inflated, and the guiding catheter will move counterclockwise about the anchoring balloon when the other positioning balloon is inflated.

9. The apparatus of claim 8 wherein the means for inflating and deflating the positioning balloons are operable synchronously so that when one of the balloons is being deflated the other is being inflated.

10. The apparatus of claim 3 wherein the deposit removal tool includes an elongated shaft.

11. The apparatus of claim 10 further comprising a positioning catheter carried within the guiding catheter, the positioning catheter being rotatable with respect to the guiding catheter and including an off-center lumen in which the shaft of the deposit removal tool is closely received, whereby rotation of the positioning catheter allows selective positioning of the deposit removal tool.

12. The apparatus of claim 1 wherein the deposit removal tool includes a distal tip portion, an elongated shaft portion extending proximally from the tip, and a catheter disposed about the shaft portion, the catheter having a distal end adjacent the distal tip portion through which dislodged deposits and blood may be aspirated.

13. The apparatus of claim 12 further comprising means for filtering and returning the aspirated blood to the patient.

14. The apparatus of claim 1 wherein the deposit removal tool comprises a rotatable cutting

device.

15. The apparatus of claim 1 wherein the deposit removal tool comprises a rotatable abrading device.

16. The apparatus of claim 1 wherein the deposit removal tool comprises an ultrasonic vibrations generator and a wire capable of conveying such ultrasonic vibrations connected to the generator and having a distal end locatable adjacent the aortic valve.

17. The apparatus of claim 1 wherein the deposit removal tool comprises a high voltage power source and a pair of electrical discharge electrodes positionable adjacent the aortic valve.

18. The apparatus of claim 1 wherein the deposit removal tool comprises a laser and an optical fiber connected to the laser.

19. The apparatus of claim 4 including a collapsible guiding catheter insertion sleeve having a distal end portion attached to the intermediate portion of the circumferential band.

20. The apparatus of claim 19 wherein the collapsible insertion sleeve is wider proximally than it is in its distal end portion, so that it receives the guiding catheter closely only in the distal end portion, allowing easy insertion and withdrawal of the guiding catheter through the insertion sleeve.

21. The apparatus of claim 3 wherein the attachment means comprises first and second straps, each having a first end attached to the anchoring balloon and a second end attached to the guiding catheter, the straps being attached so that as the guiding catheter is rotated with respect to the anchoring balloon one of the straps will wind up on the guiding catheter and the other will unwind off the

guiding catheter, causing the guiding catheter to move about the periphery of the anchoring balloon.

22. The apparatus of claim 21 wherein the first strap comprises two such straps straddling the second strap.

23. The apparatus of claim 1 wherein the anchoring balloon catheter includes an inflatable balloon having proximal and distal portions, the distal portion of the balloon being inflatable to a diameter larger than the proximal portion.

24. The apparatus of claim 23 wherein the valve is of the type having multiple leaflets with superior and inferior surfaces, the distal and proximal portions of the balloon defining a shoulder that is engagable with the inferior surface of the valve leaflets to support the leaflets as deposits are removed from the superior surface thereof.

25. The apparatus of claim 24 wherein the proximal portion of the balloon is generally elongated and cylindrical in shape and having an outer surface, the shoulder being formed by attaching a secondary distal balloon portion to the outer surface of the proximal balloon portion.

26. The apparatus of claim 24 wherein the balloon has a longitudinal axis, the shoulder portion of the balloon being made of a stretchable material so that it can conform to the inferior surface of the leaflet, other portions of the balloon being constructed to be substantially non-stretchable in a direction perpendicular to the longitudinal axis.

27. The apparatus of claim 1 wherein the anchoring balloon catheter comprises an inflatable helically coiled tube and securing means for securing windings of the helically coiled tube with respect to one another in a desired configuration.

- 30 -

28. The apparatus of claim 27 wherein the securing means comprises a flexible skin attached to the turns of the coil.

29. The apparatus of claim 1 further including a cardiopulmonary bypass system comprising a vein access catheter insertable into a vein to allow removal of blood therefrom, oxygenator means for oxygenating such blood, an artery access catheter insertable into an artery, and pump means for returning the blood through the artery access catheter to the artery.

30. The apparatus of claim 29 wherein the anchoring balloon catheter includes a catheter having proximal and distal ends and a lumen, the lumen being open at the distal end of the catheter, the proximal end of the catheter lumen being operatively connected to the pump means so that when the anchoring balloon catheter is fixated across the aortic valve blood may be removed through such lumen and returned to the artery.

31. The apparatus of claim 29 wherein the cardiopulmonary bypass system includes a filter and a heat exchanger through which the blood passes before it is returned to the artery.

32. The apparatus of claim 29 further including a left ventricle access catheter insertable through the iliac vein, vena cava, through the right atrium and left atrium to the left ventricle, the left ventricle access catheter being operatively connectable to the pump means to allow blood flow from the left ventricle and its return to the artery.

33. The apparatus of claim 32 wherein the vein access catheter and the left ventricle access catheter are arranged in one catheter.

34. The apparatus of claim 33 wherein the



vein access catheter and the left ventricle access catheter are arranged in a single lumen catheter having orifices in a wall thereof to define a distal end of the vein access catheter.

35. The apparatus of claim 33 wherein the vein access catheter and the left ventricle access catheter are arranged in a double lumen catheter.

36. The apparatus of claim 33 wherein the vein access catheter and the left ventricle access catheter are arranged in a co-axial double lumen catheter.

37. The apparatus of claim 1 further including ultrasound transducing means disposed within the anchoring balloon for imaging the aortic valve, the location of the deposit removal tool, and the location of the deposits to be removed.

38. The apparatus of claim 37 wherein the ultrasound transducing means comprises a phased array transducer comprised of an array of individual acoustic elements.

39. The apparatus of claim 37 wherein the ultrasound transducing means comprises an echo transducer and a rotatable mirror element positionable in the anchoring balloon catheter.

40. The apparatus of claim 37 wherein the anchoring balloon catheter includes a catheter lumen, the ultrasound transducing means being carried by a catheter positionable within the lumen of the anchoring balloon catheter and being movable distally and proximally within the lumen.

41. The apparatus of claim 37 wherein the anchoring balloon catheter includes a central catheter, the ultrasound transducing means being carried by the central catheter.

42. The apparatus of claim 3 wherein the

- 32 -

positioning means includes a pair of cords attached distally to the anchoring balloon, and pulleys mounted on the guiding catheter and the anchoring balloon, the cords being threaded through the pulleys so that pulling on a first of the cords and releasing the second cord will cause the guiding catheter to move clockwise about the anchoring balloon and, pulling the second cord and releasing the first cord will cause the guiding catheter to move counterclockwise about the anchoring balloon.

43. The apparatus of claim 1 wherein the anchoring balloon catheter includes a catheter having a distal end and a lumen, the lumen being open at the distal end of the catheter, and has a check valve opening into the aorta.

44. The apparatus of claim 1 wherein the anchoring balloon comprises an inflatable helically coiled tube defining a distally open lumen.

45. The apparatus of claim 44 wherein the helically coiled tube includes a thin skin thereon to hold windings of the helically coiled tube in position with respect to one another.

46. The apparatus of claim 45 wherein the anchoring balloon includes check valve means for permitting blood to flow through the lumen out of the heart's left ventricle and substantially preventing blood from flowing through such lumen back into the left ventricle.

47. The apparatus of claim 46 wherein the check valve means is disposed on the skin of the helically coiled tube.

48. The apparatus of claim 46 wherein the check valve means comprises a leaflet-type valve disposed across the lumen of the anchoring balloon.

49. The apparatus of claim 48 wherein the

leaflet-type valve is disposed across the lumen at the proximal end of the anchoring balloon.

50. The apparatus of claim 44 further comprising a screw-type pump means disposed in the lumen for pumping blood across the aortic valve.

51. The apparatus of claim 50 wherein the screw-type pump means comprises two or more screw-type pumps operating in parallel, each having an intake drawing blood distally from the lumen and an outlet discharging the blood proximally into the aorta.

52. The apparatus of claim 50 further comprising a second screw-type pump means for withdrawing blood from adjacent the deposit removal tool, and for filtering such blood and returning it to the aorta.

53. The apparatus of claim 52 wherein the second screw-type pump means includes catheter means defining a blood flow path that is operatively isolated from the open lumen of the anchoring balloon and the first screw-type pump means, the catheter means including a distal end located adjacent the deposit removal tool and a proximal portion connected to an inlet of the second screw-type pump means, the second screw-type pump means further including an outlet to the aorta.

54. The apparatus of claim 3 wherein the attachment means securing the tool to the anchoring balloon prevents any substantial movement of the guiding catheter with respect to the anchoring balloon catheter, the tool being positionable with respect to the aortic valve by rotating the anchoring balloon catheter.

55. Apparatus for in vivo removal of deposits from an aortic valve, comprising:  
an anchoring balloon catheter fixatable across

- 34 -

the aortic valve;

a deposit removal tool having an elongated shaft;  
a guiding catheter through which the tool may be advanced toward the aortic valve, the guiding catheter including a distal end portion;

a circumferential band having first and second ends respectively attached to the anchoring balloon, and an intermediate portion operatively connected to the guiding catheter;

a pair of positioning balloons interposed between the circumferential band and the anchoring balloon for selectively moving the guiding catheter about the anchoring balloon in response to inflation and deflation of the positioning balloons;

means for selectively inflating and deflating the positioning balloons whereby the guiding catheter will move clockwise about the anchoring balloon when one of the positioning balloons is inflated, and the guiding catheter will move counterclockwise about the anchoring balloon when the other positioning balloon is inflated; and

a positioning catheter carried within the guiding catheter, the positioning catheter being rotatable with respect to the guiding catheter and including an off-center lumen in which the shaft of the deposit removal tool is closely received, whereby rotation of the positioning catheter allows selective positioning of the deposit removal tool.

56. A method of removing deposits from an aortic valve's superior surface, comprising;

advancing an anchoring balloon through the aorta and positioning it across the aortic valve;

inflating the anchoring balloon to fixate it with respect to the aorta and aortic valve; and

operating a deposit removal tool secured to the

anchoring balloon to remove the deposits.

57. The method of claim 56 including the step of advancing the deposit removal tool through the aorta after the anchoring balloon has been inflated.

58. The method of claim 57 wherein the step of advancing the deposit removal tool comprises advancing the tool through a catheter that has its distal end secured with respect to the anchoring balloon.

59. The method of claim 56 wherein the step of advancing the anchoring balloon includes the step of simultaneously advancing the deposit removal tool and the anchoring balloon through the aorta.

60. The method of claim 56 including the steps of withdrawing blood through a lumen of the anchoring balloon catheter, utilizing a pump if necessary, oxygenating such blood if necessary, and then returning such blood to an artery.

61. The method of claim 56 further comprising withdrawing blood adjacent the deposit removal tool.

62. The method of claim 61 further comprising filtering such blood and returning it to an artery.

63. The method of claim 56 further comprising the steps of advancing a blood removal catheter through the vena cava to the right atrium and through the atrial septum to the left atrium and into the left ventricle, and then removing blood from the left ventricle through such catheter and returning such blood to an artery while the anchoring balloon is positioned across the aortic valve.

64. The method of claim 56 further comprising the steps of providing cardiopulmonary bypass support by inserting a vein access catheter

- 36 -

into an artery, withdrawing blood through the vein access catheter, oxygenating the blood and returning it to the artery through the artery access catheter.

65. The method of claim 56 further comprising the step of imaging the area adjacent the anchoring balloon.

66. The method of claim 65 wherein the imaging step comprises radiographic imaging.

67. The method of claim 65 wherein the imaging step includes imaging with ultrasound utilizing an ultrasound transducer carried by the anchoring balloon.

68. A method of removing deposits from the aortic valve of a heart, comprising;

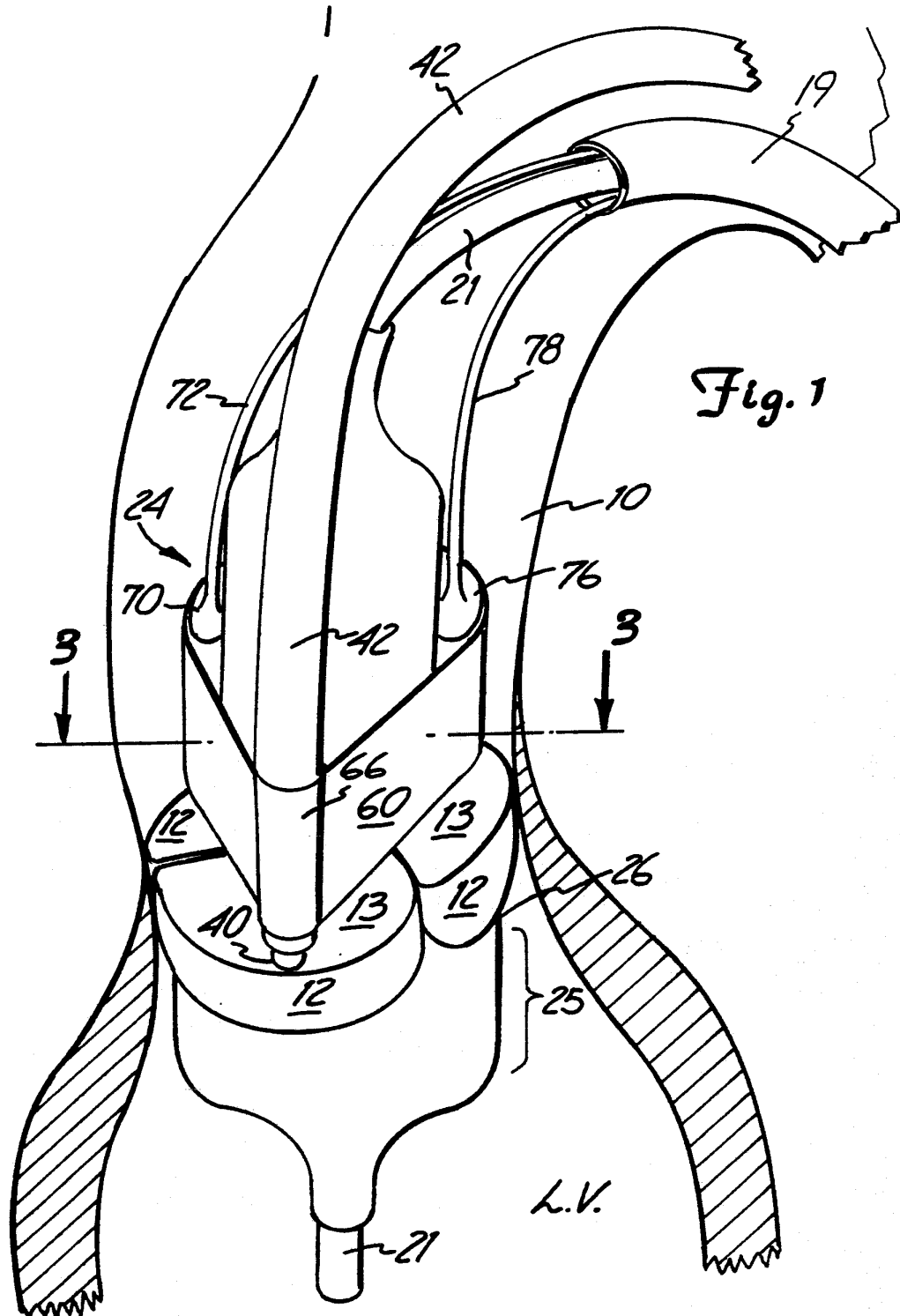
advancing a deflated, furled anchoring balloon through the aorta and positioning it across the aortic valve, the anchoring balloon including a collapsible guiding catheter sheath;

inflating the anchoring balloon to fixate it with respect to the aorta and aortic valve; and

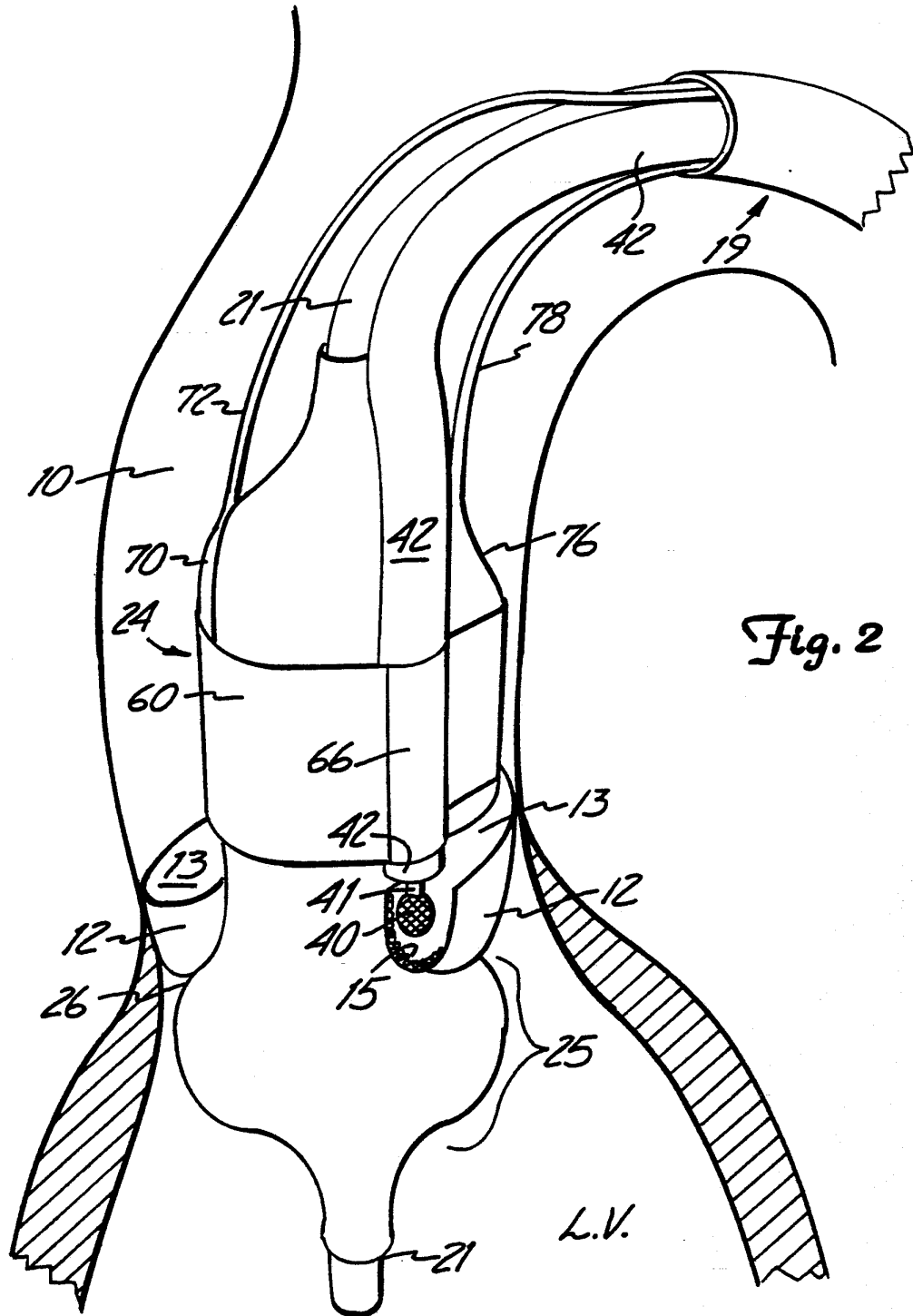
advancing a guiding catheter and a deposit removal tool through the guiding catheter sheath after the anchoring balloon has been inflated; and

operating the deposit removal tool secured to the anchoring balloon to remove the deposits.

69. The method of claim 68 further comprising withdrawing blood from the left ventricle of the heart through a catheter, and returning such blood to the aorta.



**SUBSTITUTE SHEET**



SUBSTITUTE SHEET



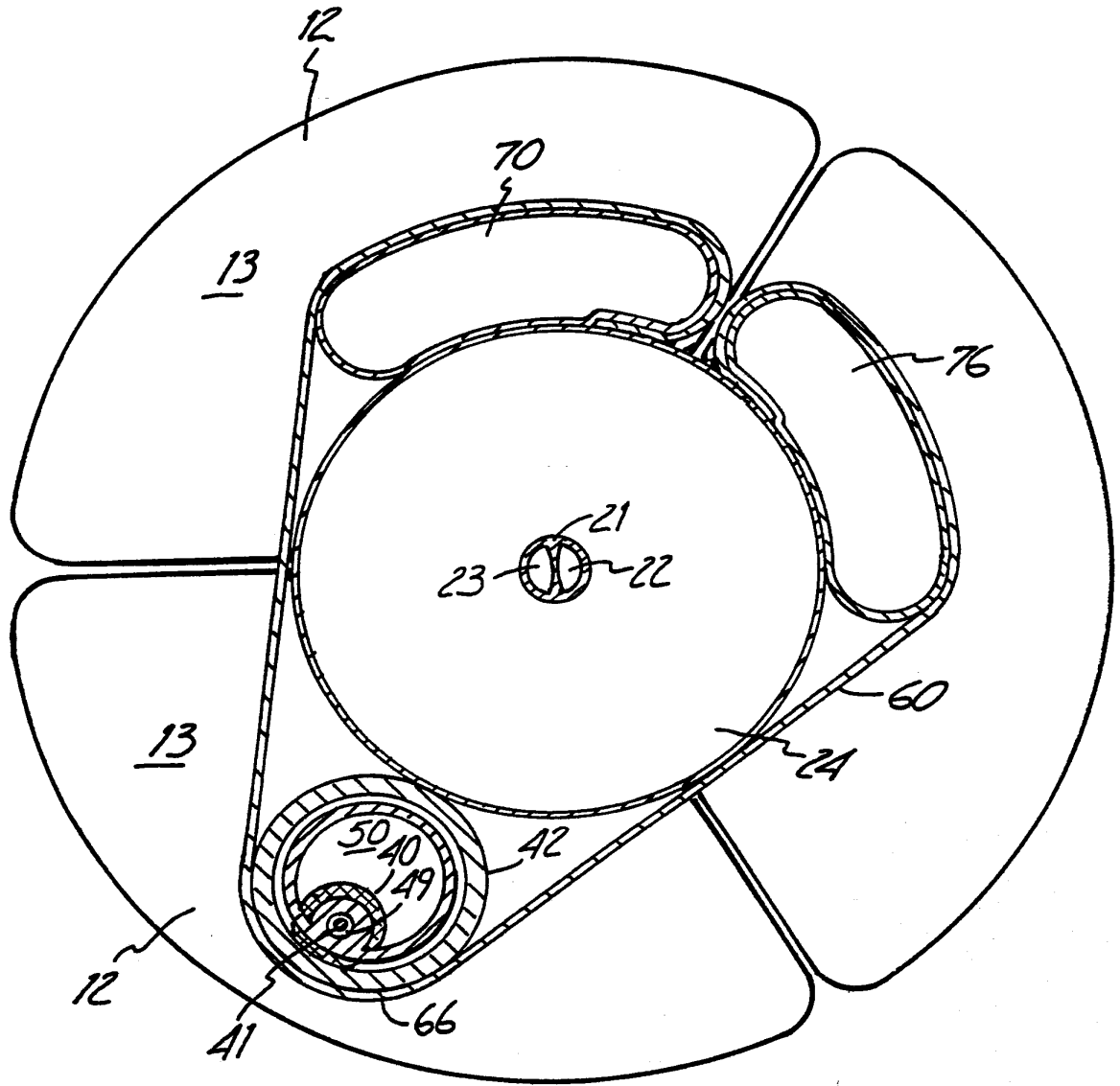


Fig. 3

SUBSTITUTE SHEET

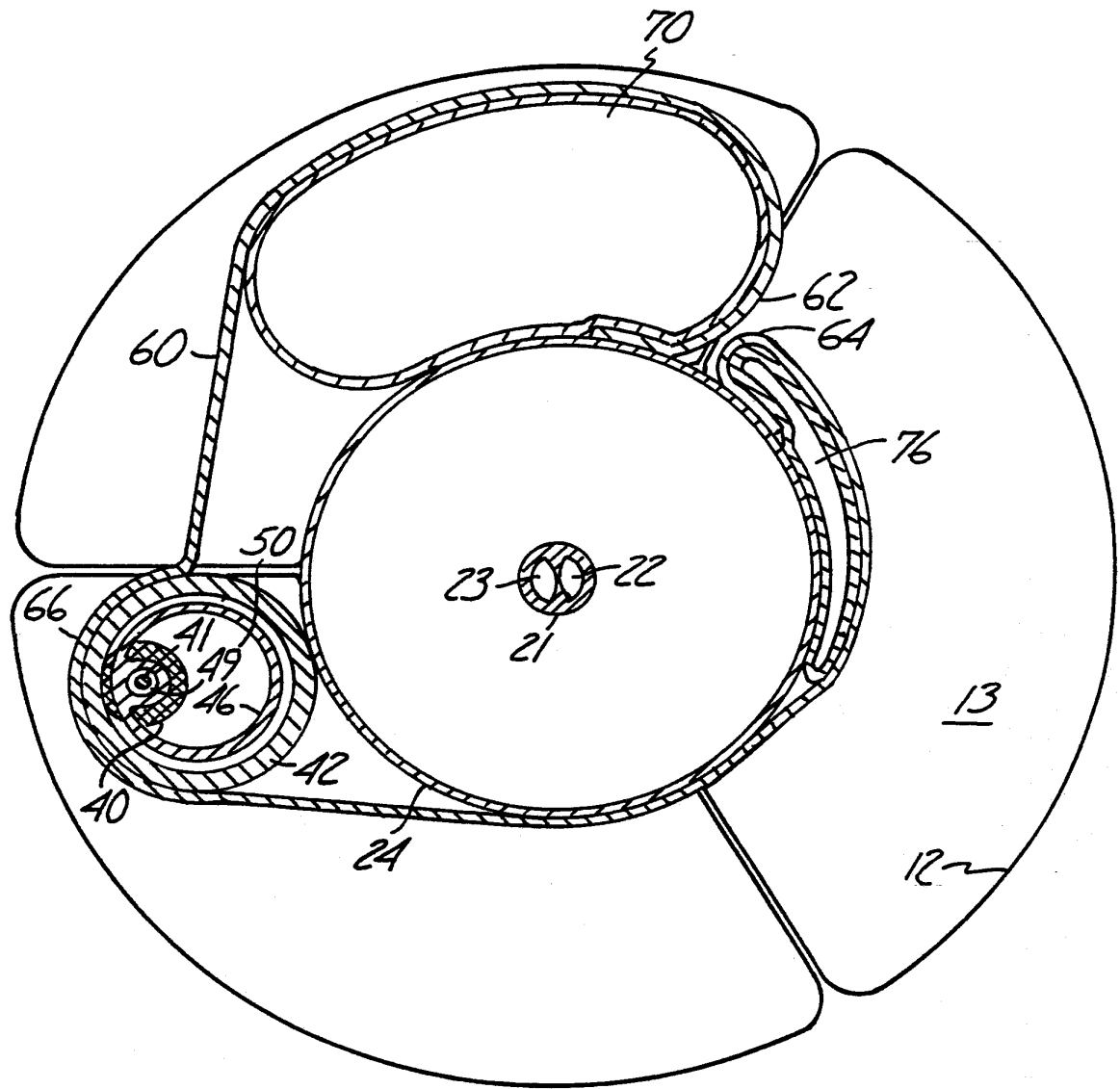
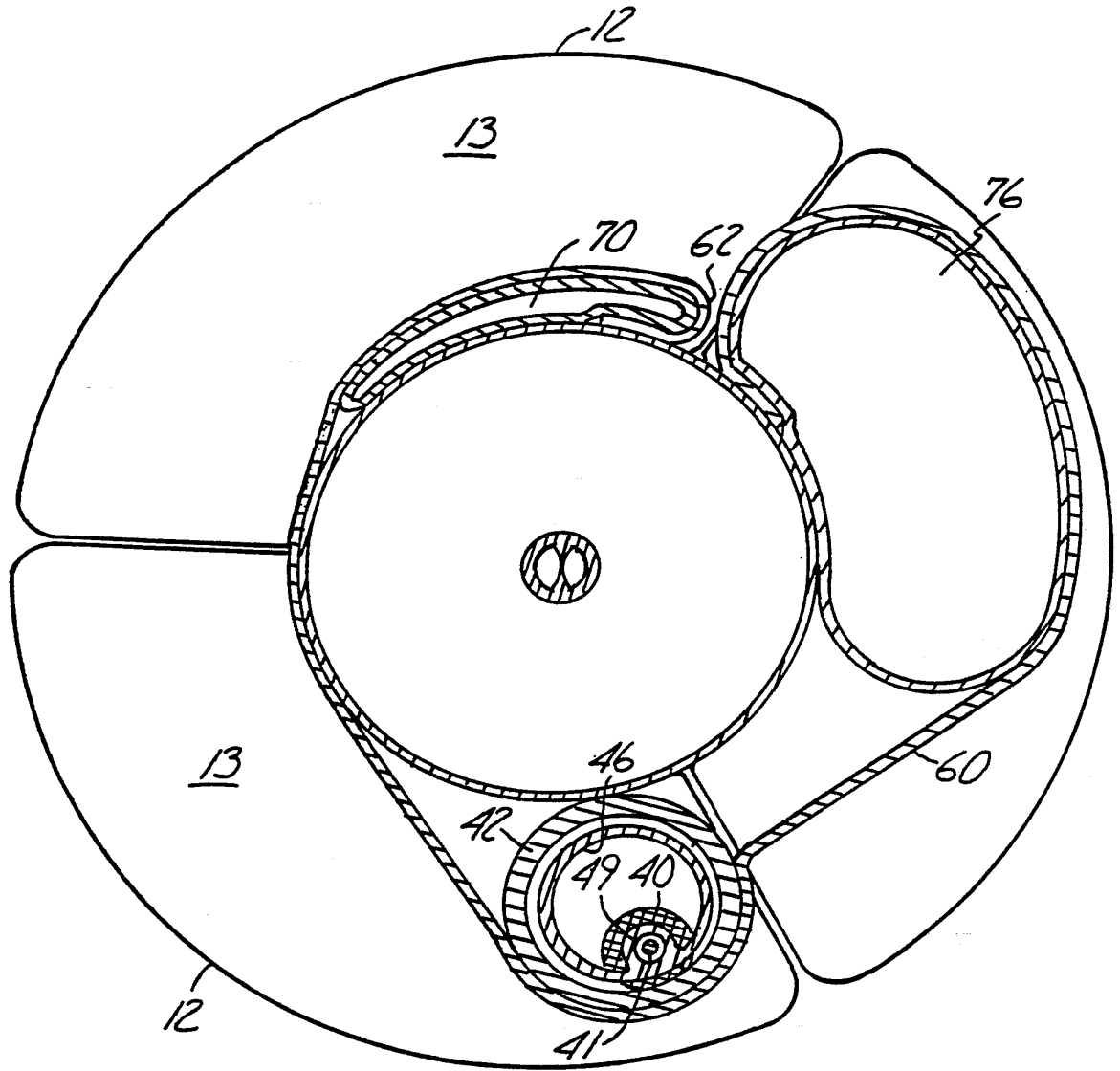


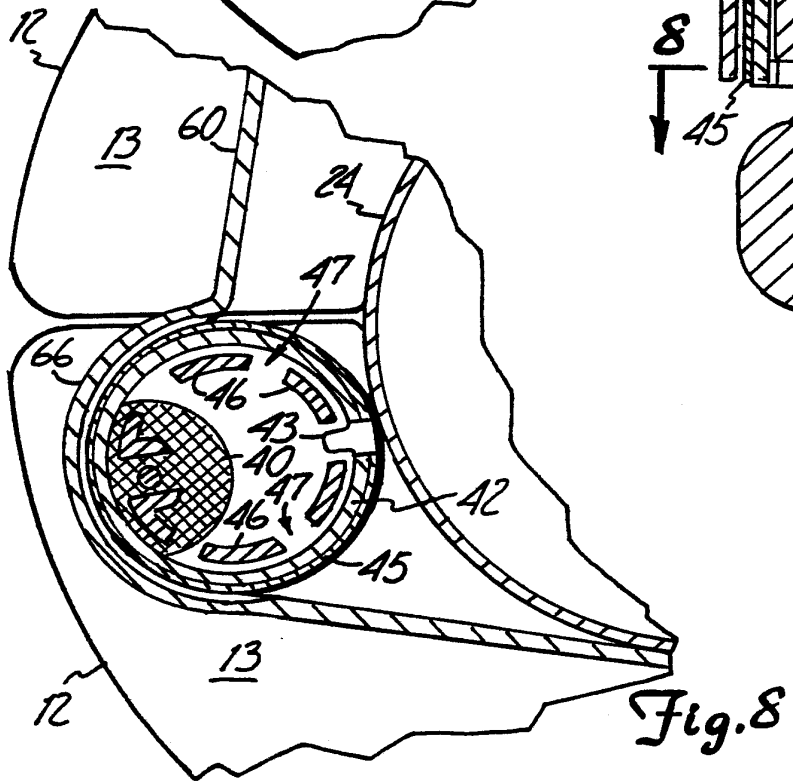
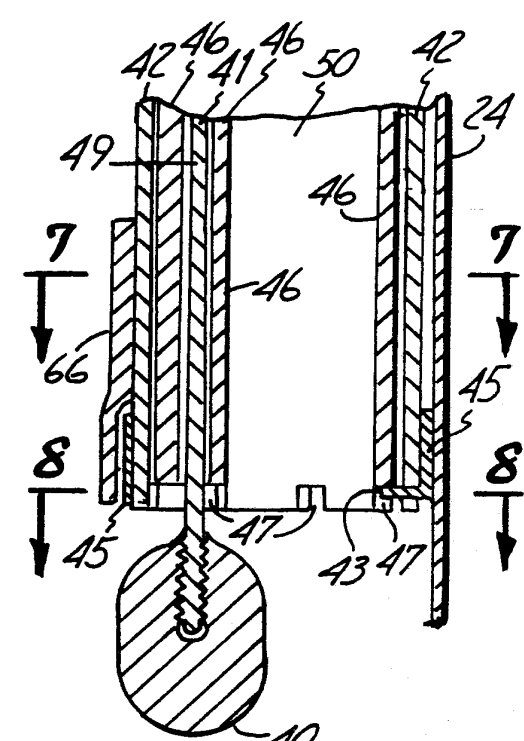
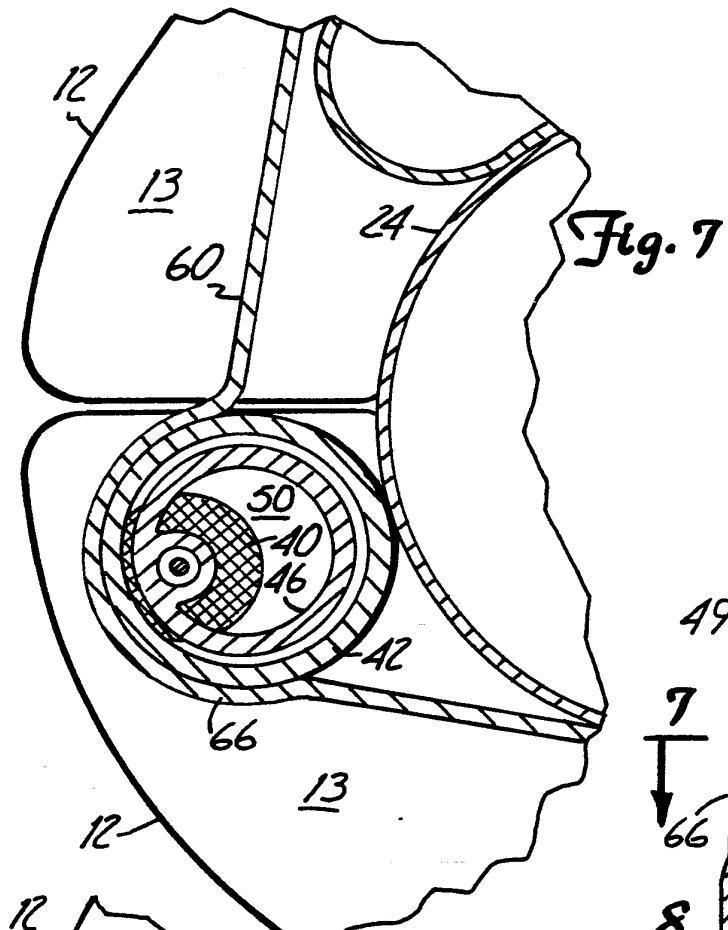
Fig. 4

SUBSTITUTE SHEET

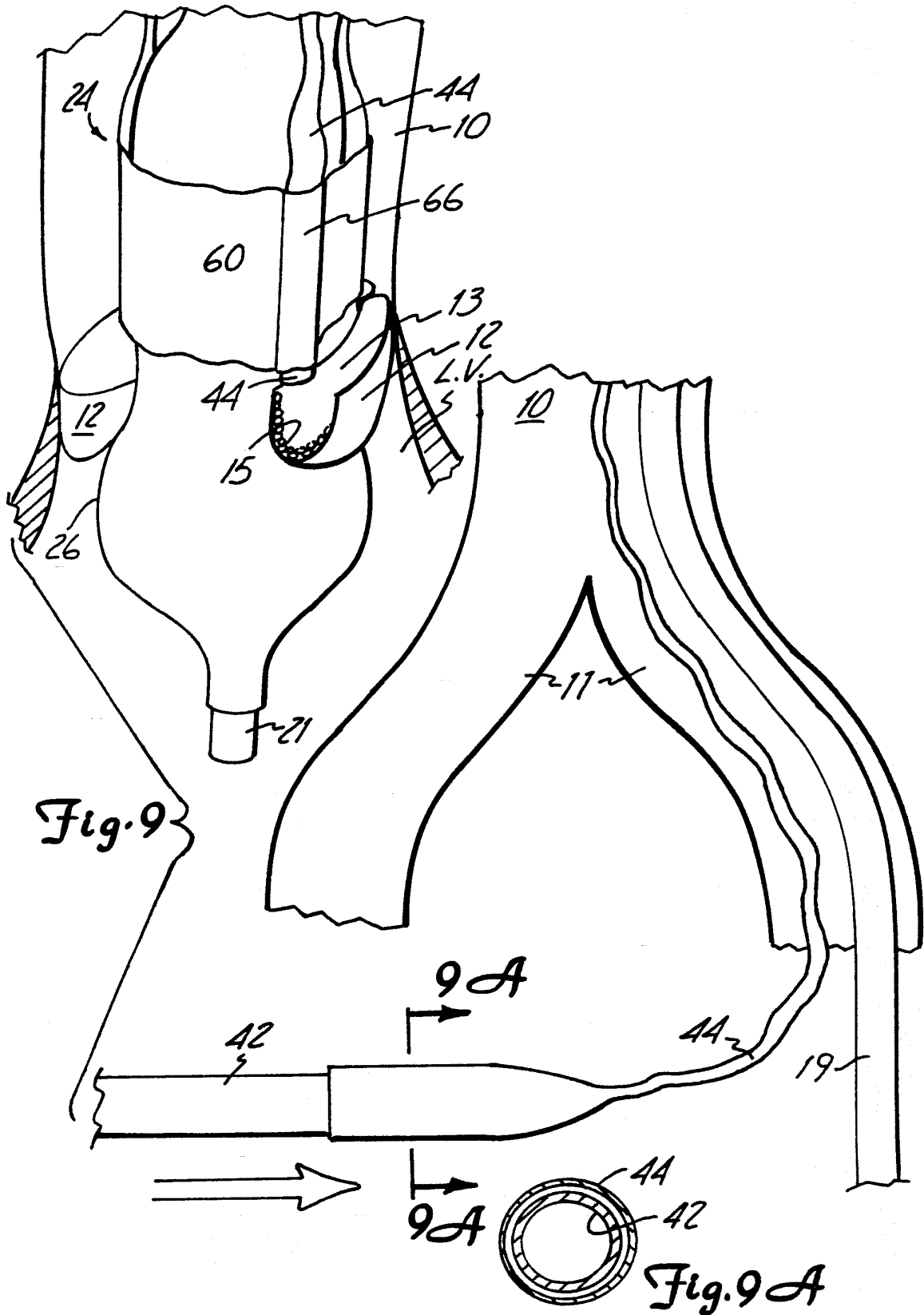


*Fig. 5*

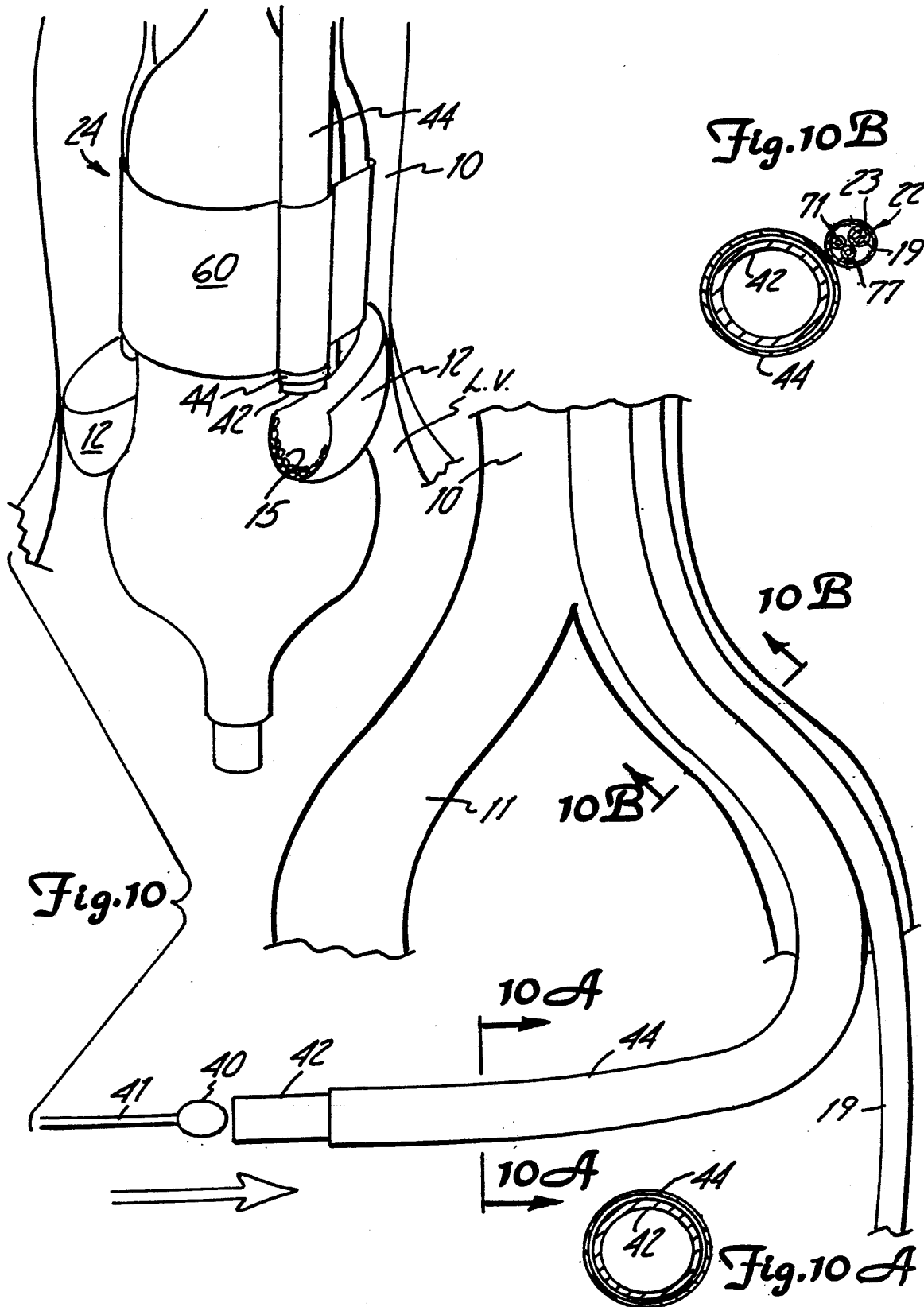
SUBSTITUTE SHEET



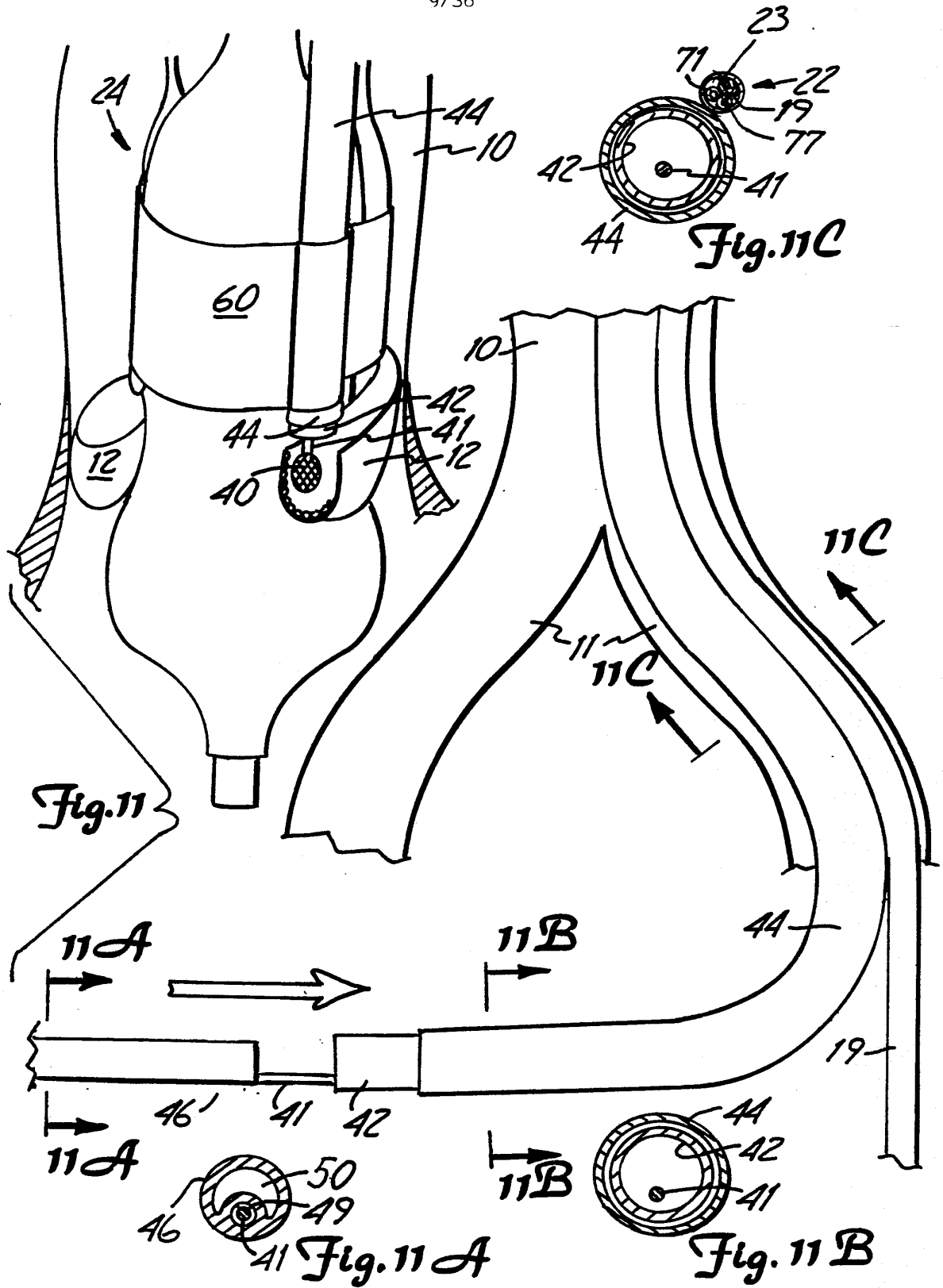
SUBSTITUTE SHEET



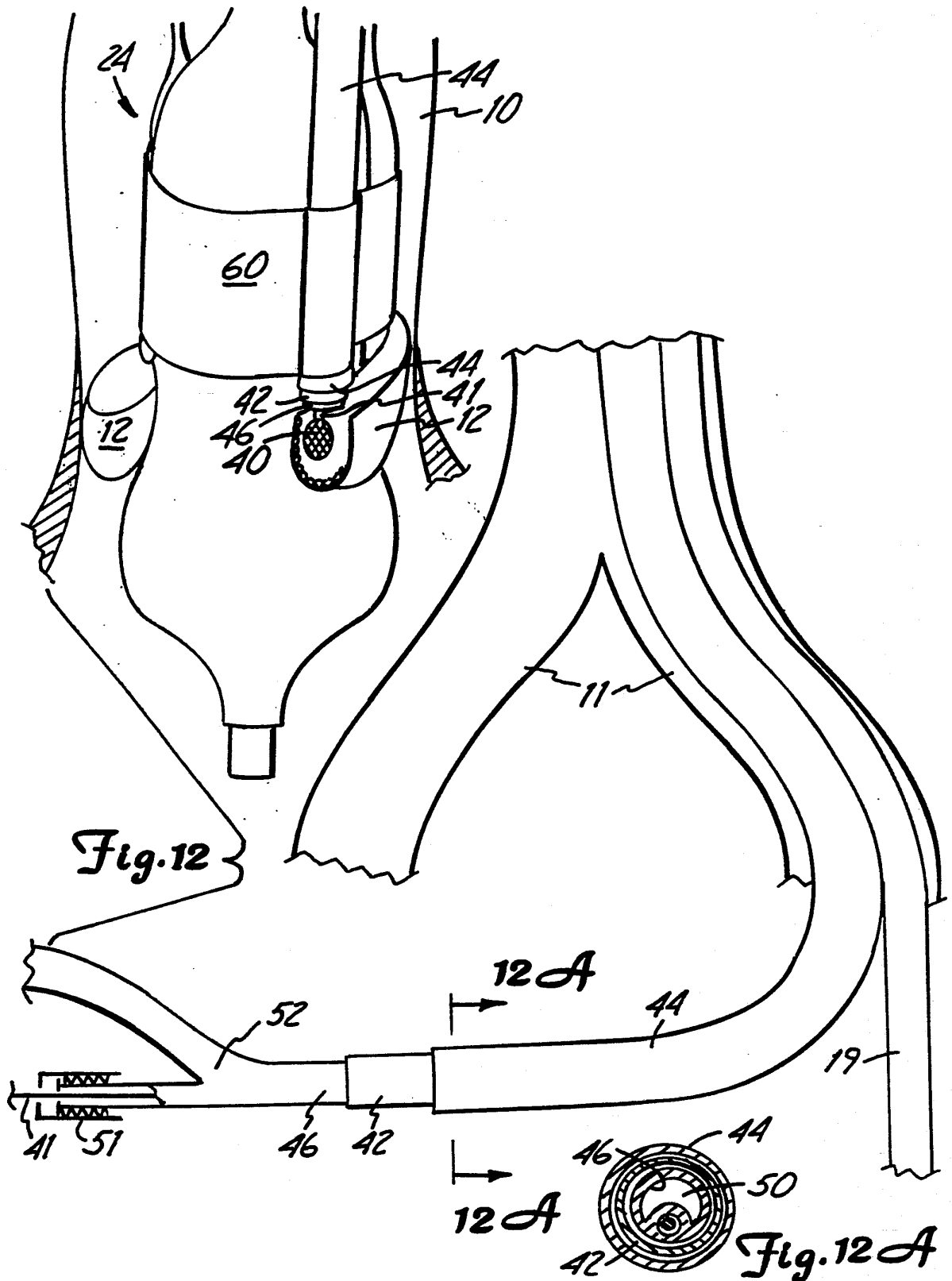
SUBSTITUTE SHEET



SUBSTITUTE SHEET



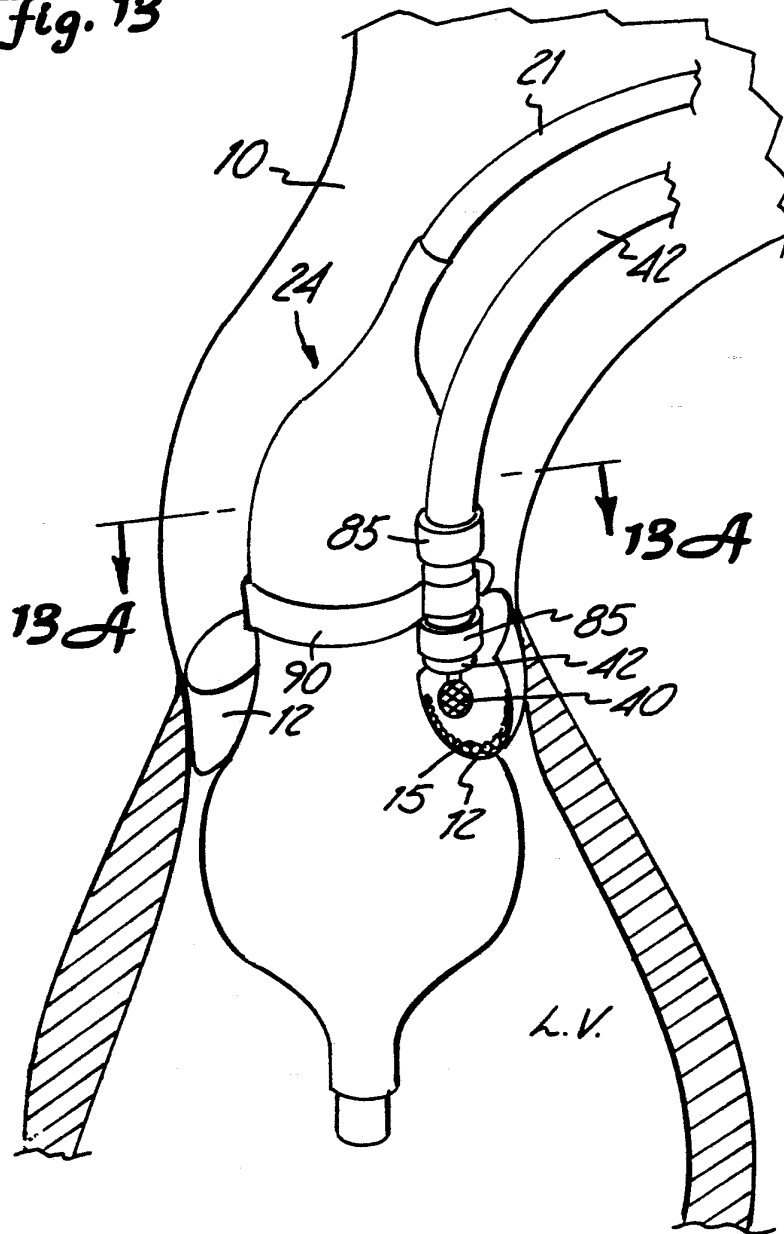
SUBSTITUTE SHEET



SUBSTITUTE SHEET



Fig. 13



SUBSTITUTE SHEET

12/36

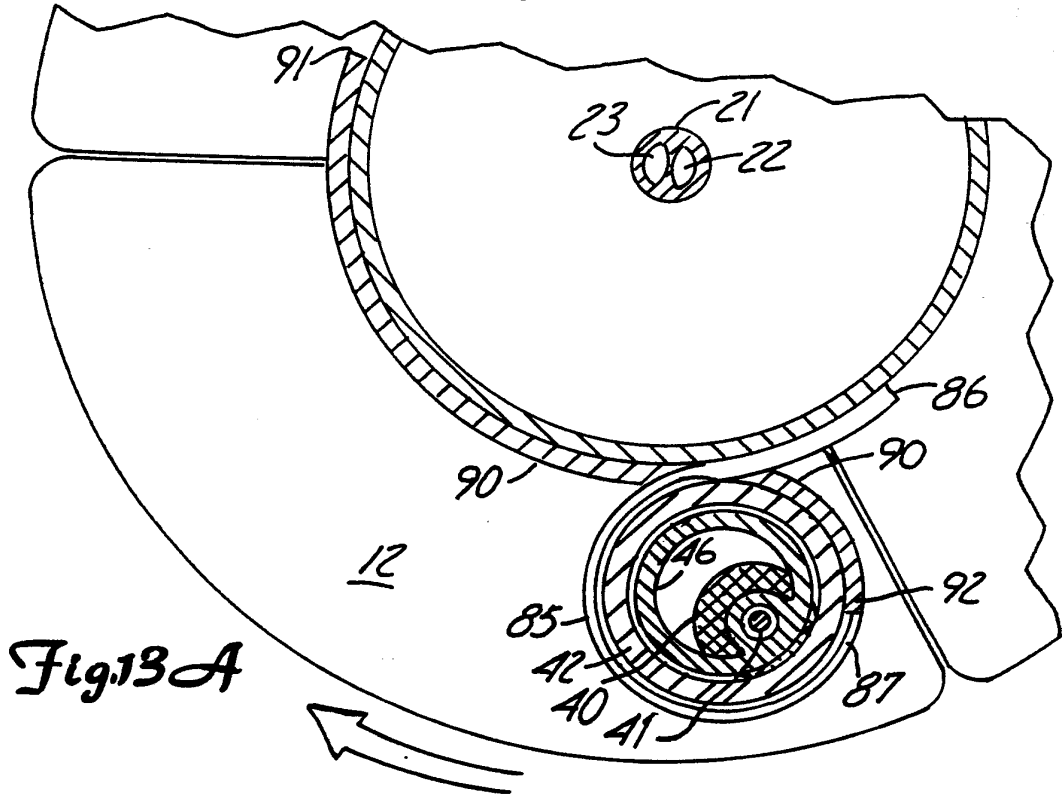


Fig. 13A

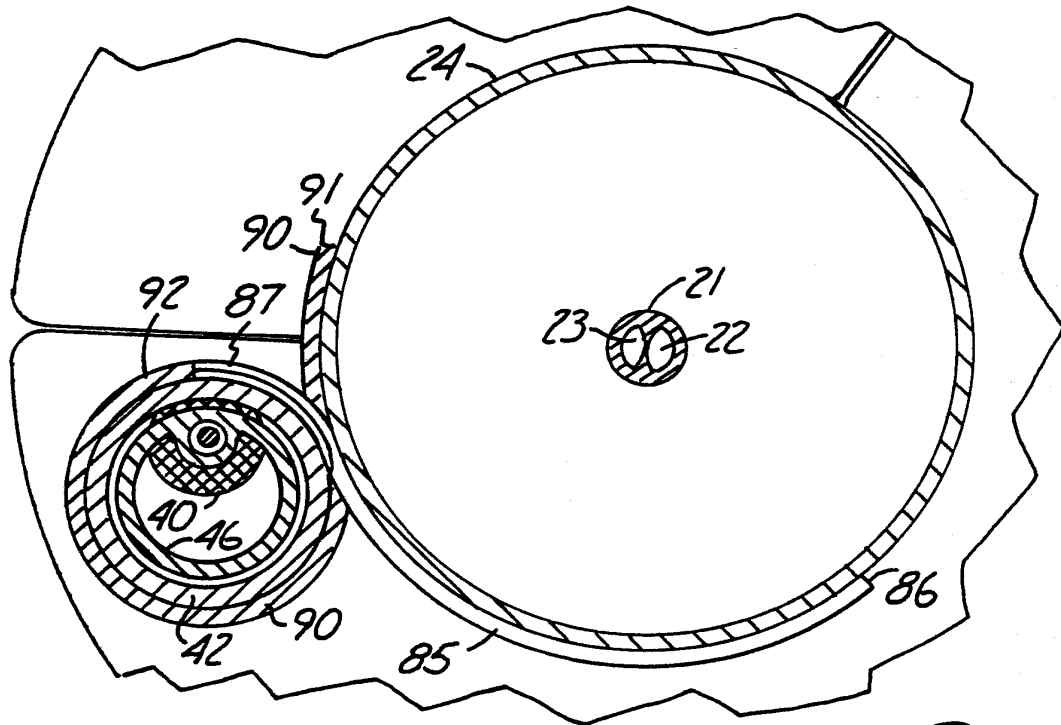
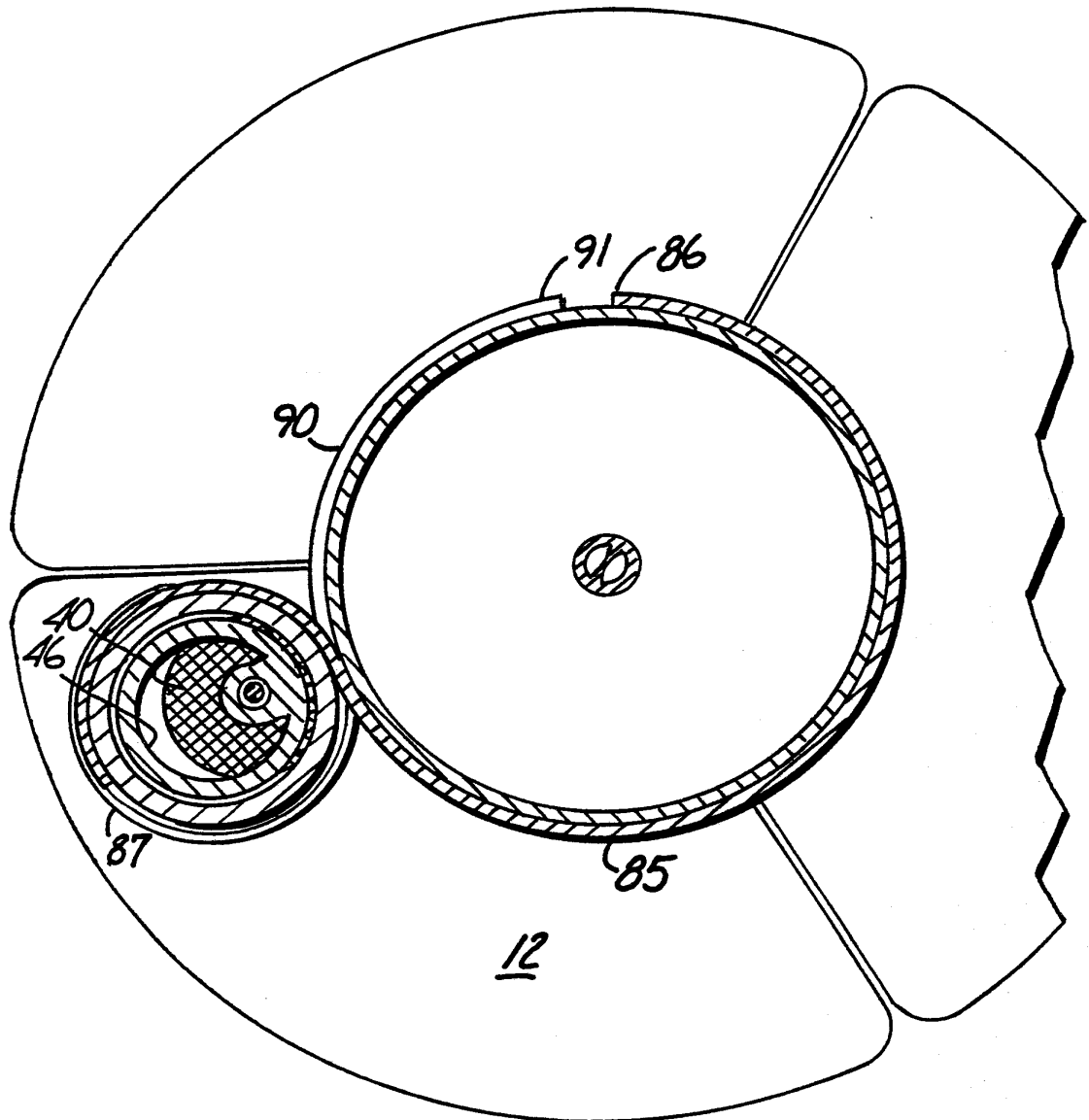


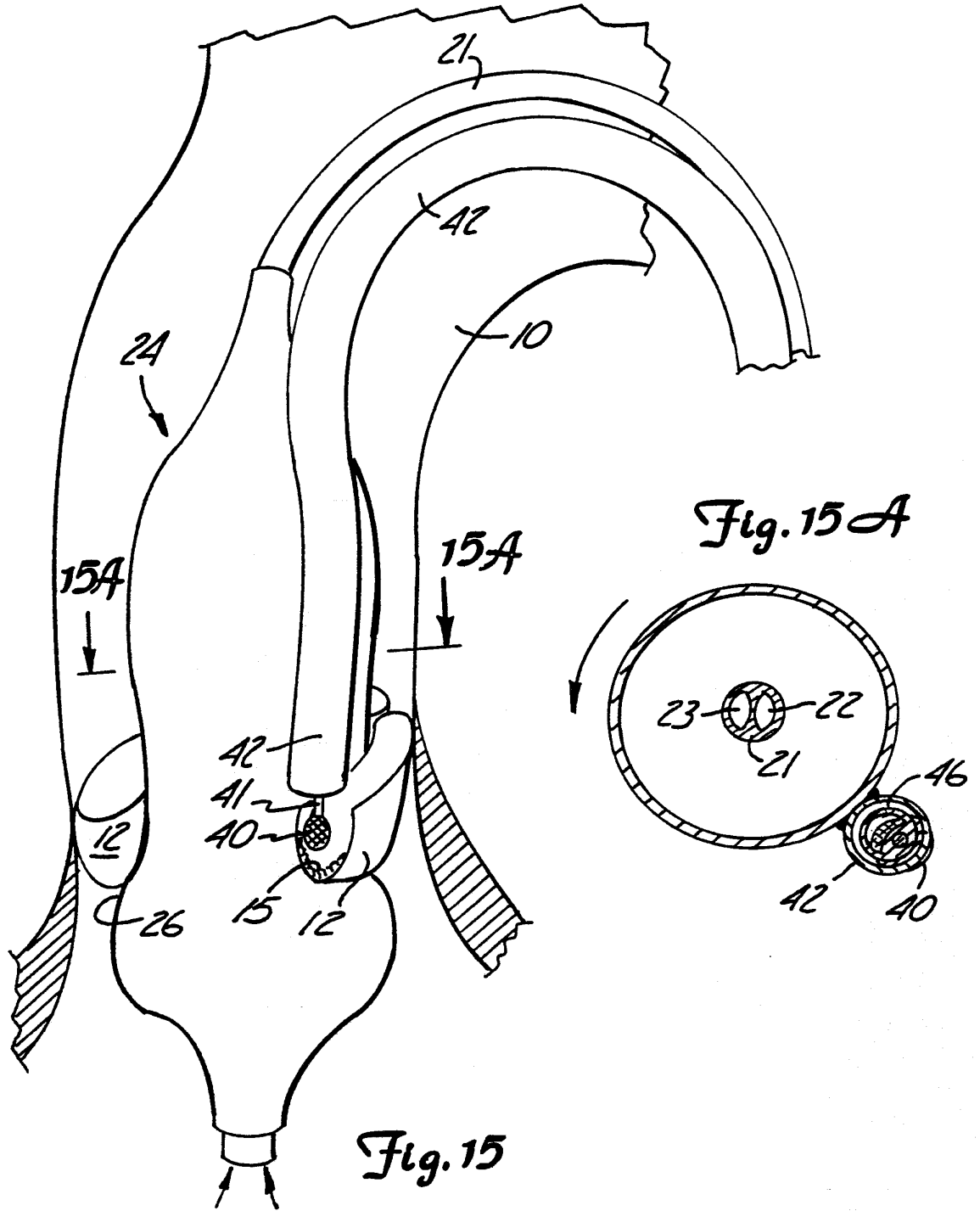
Fig. 13B

SUBSTITUTE SHEET

Fig. 14



SUBSTITUTE SHEET



SUBSTITUTE SHEET

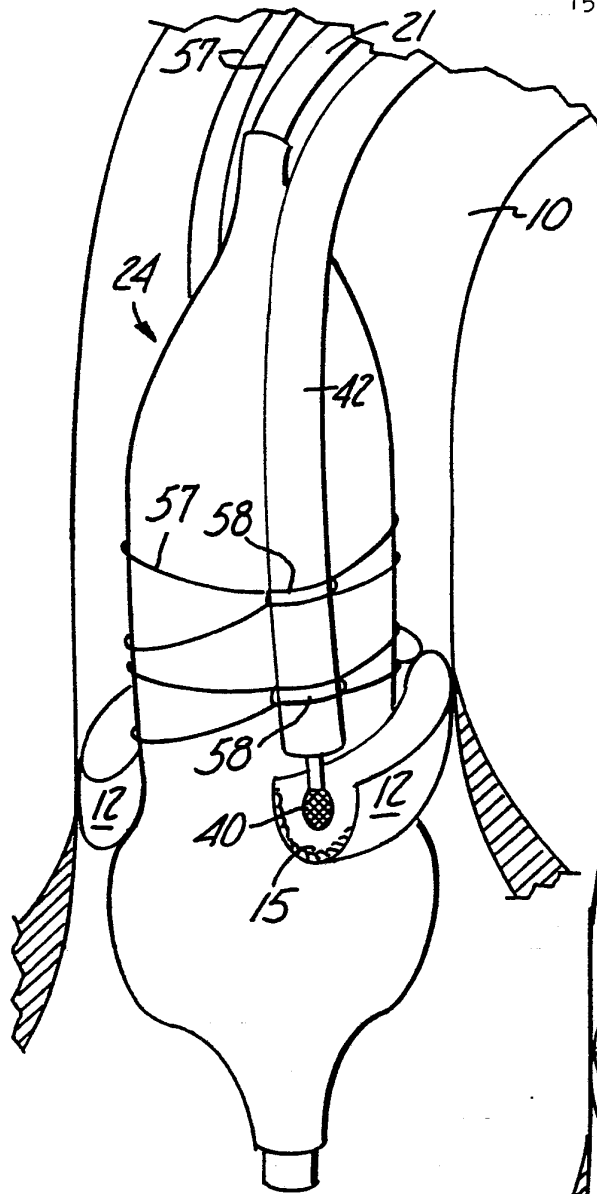


Fig. 16

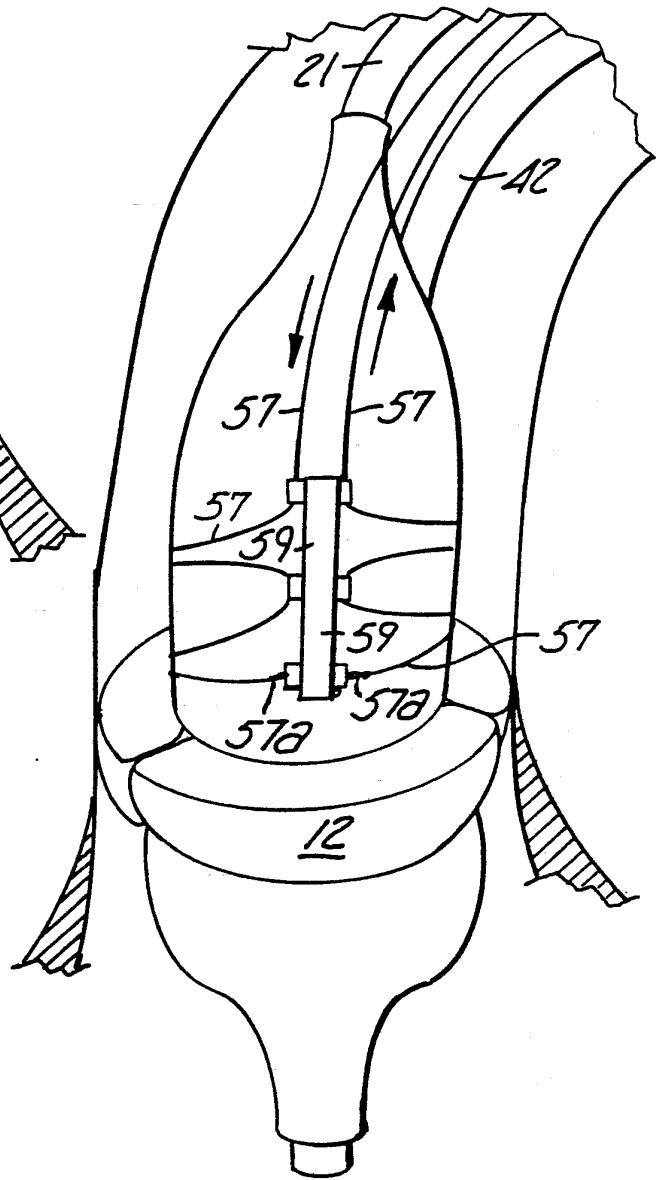


Fig. 16A

SUBSTITUTE SHEET

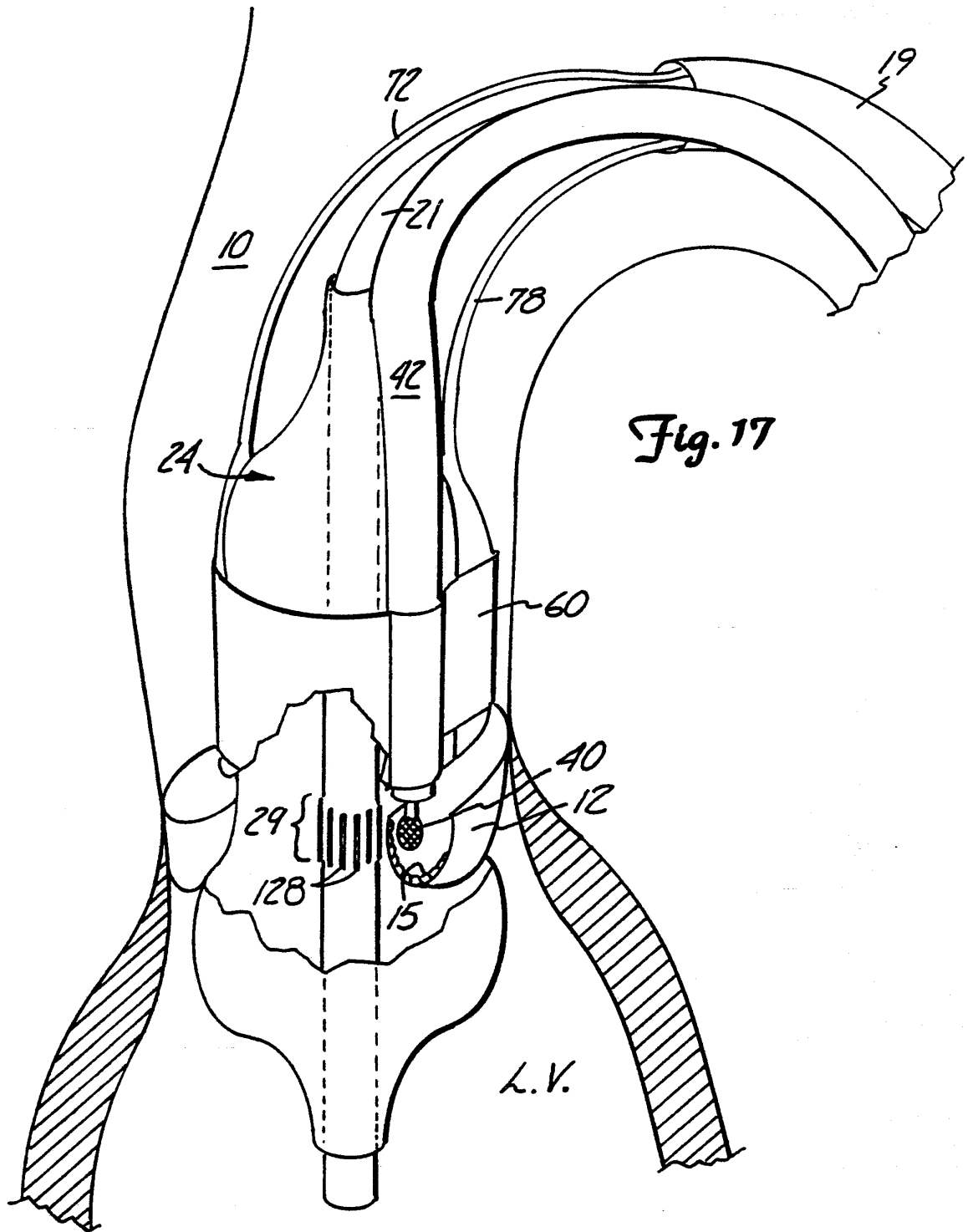


Fig. 17

SUBSTITUTE SHEET

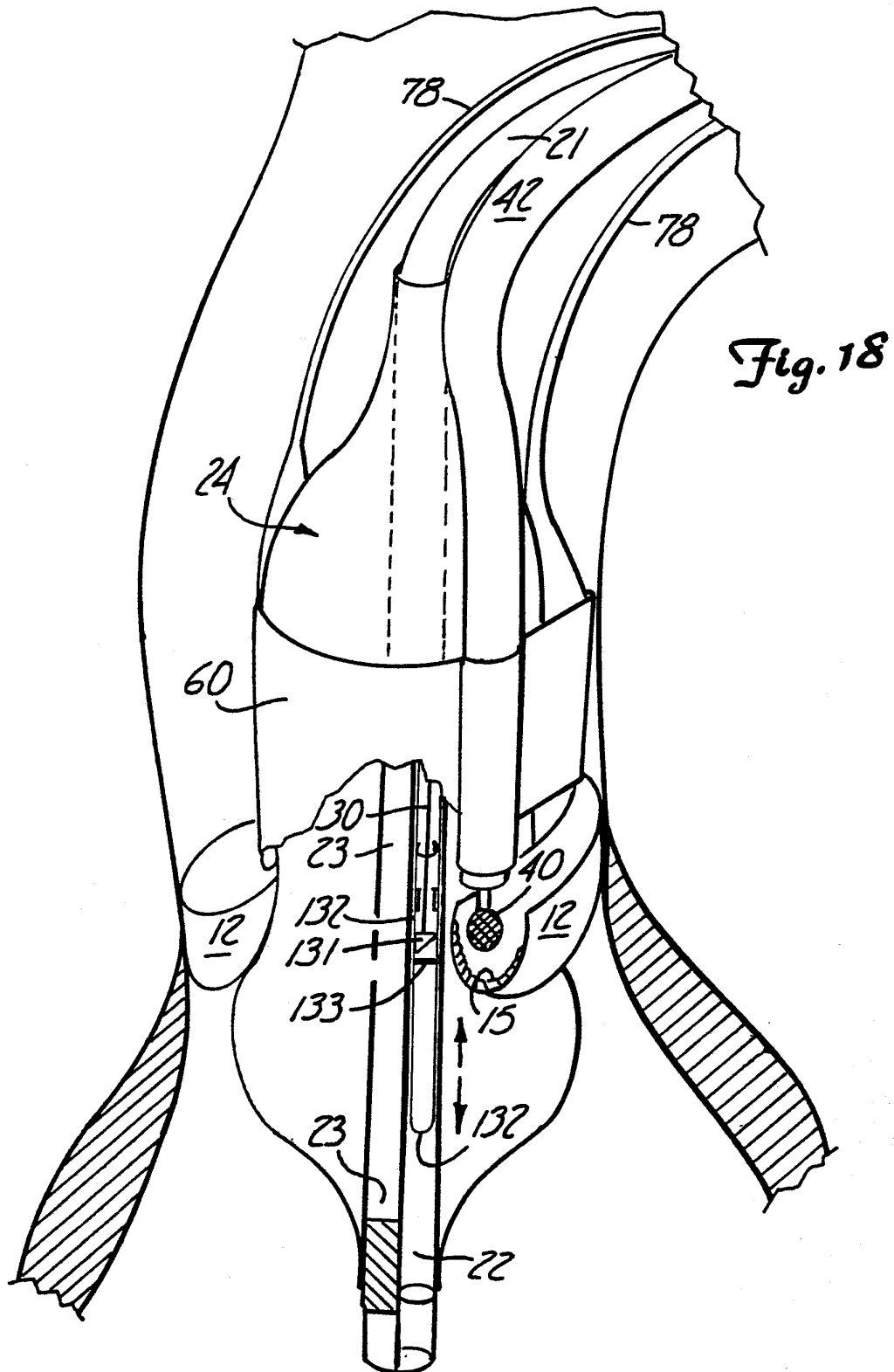
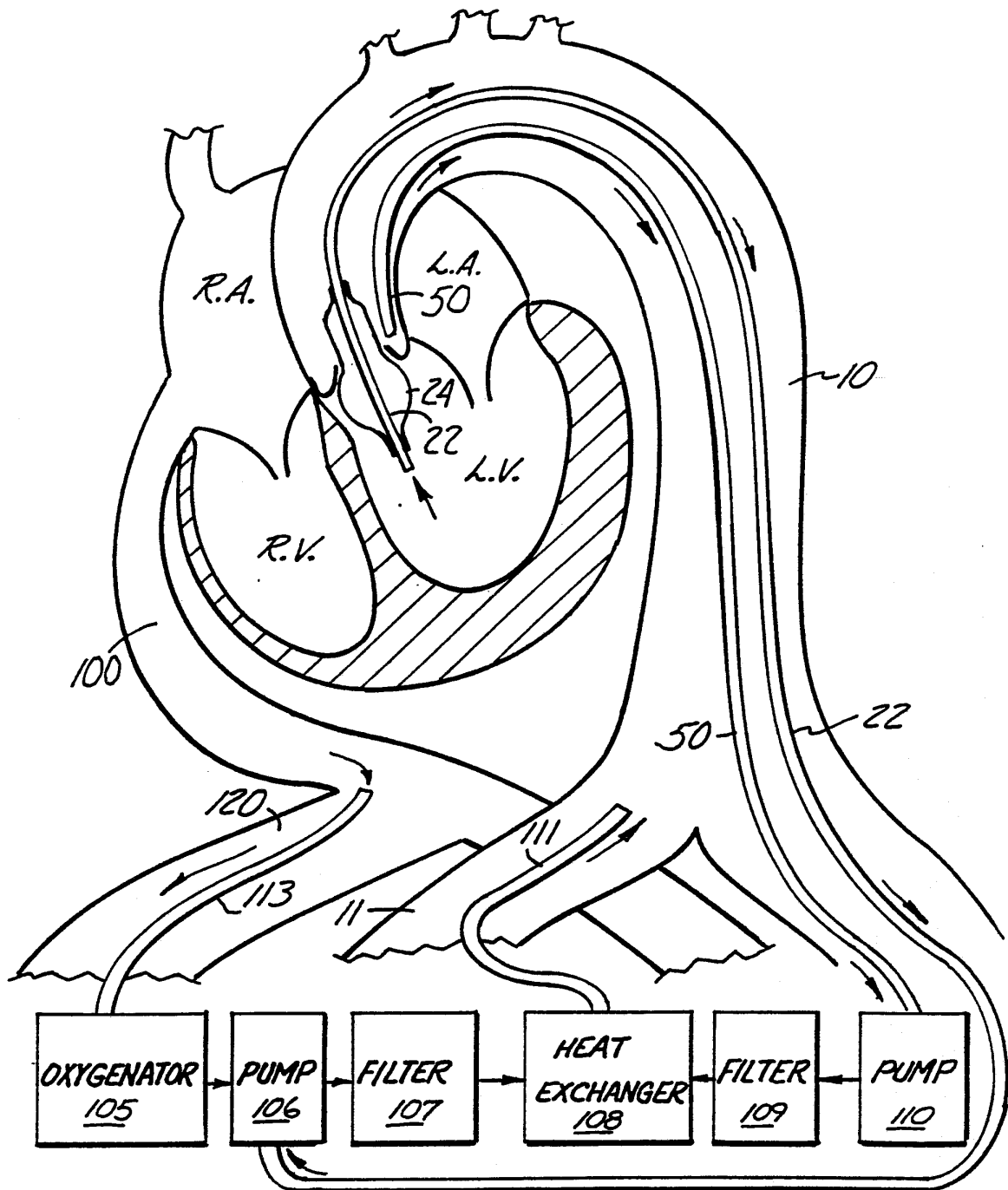


Fig. 18

SUBSTITUTE SHEET

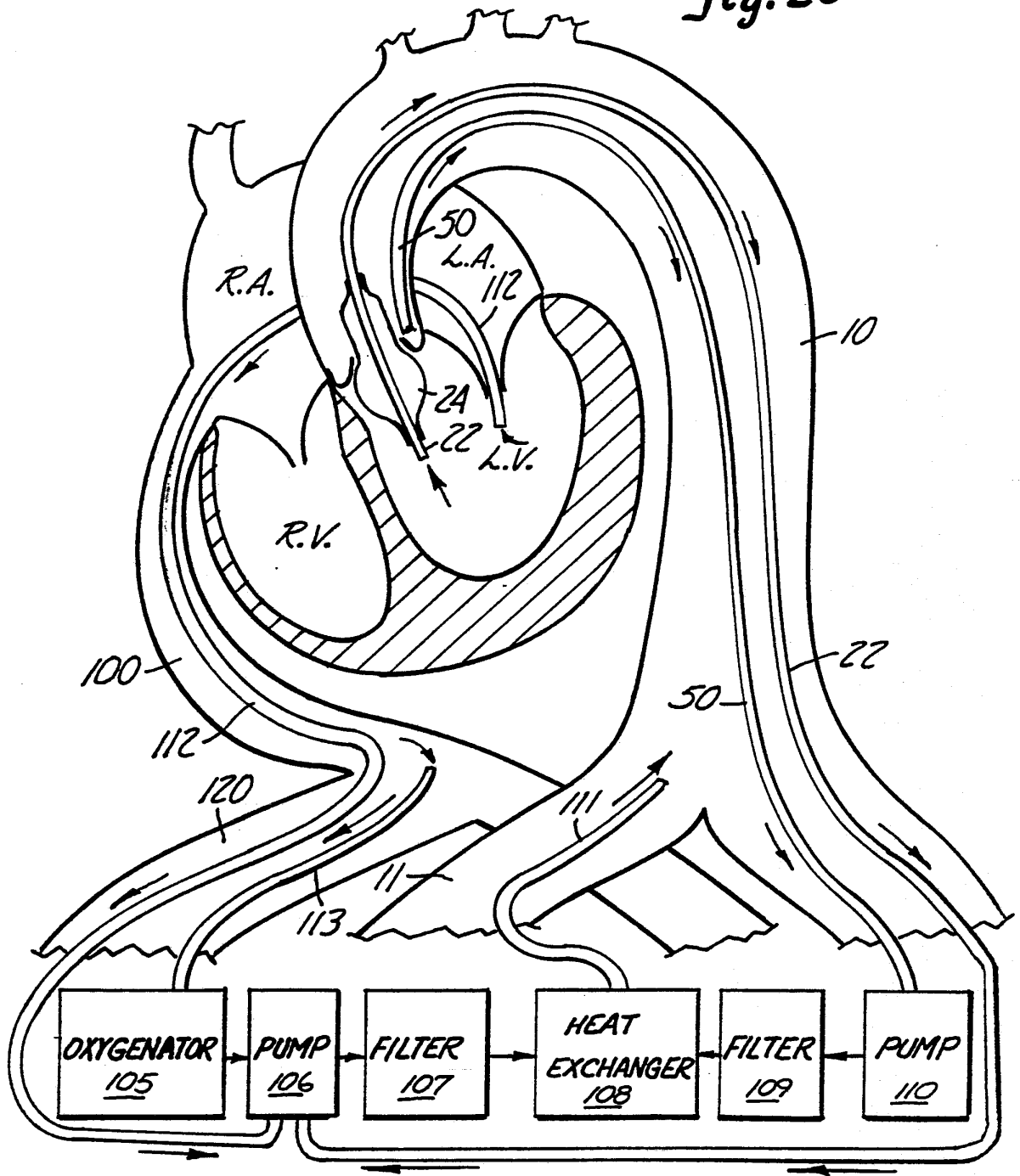
Fig. 19



SUBSTITUTE SHEET

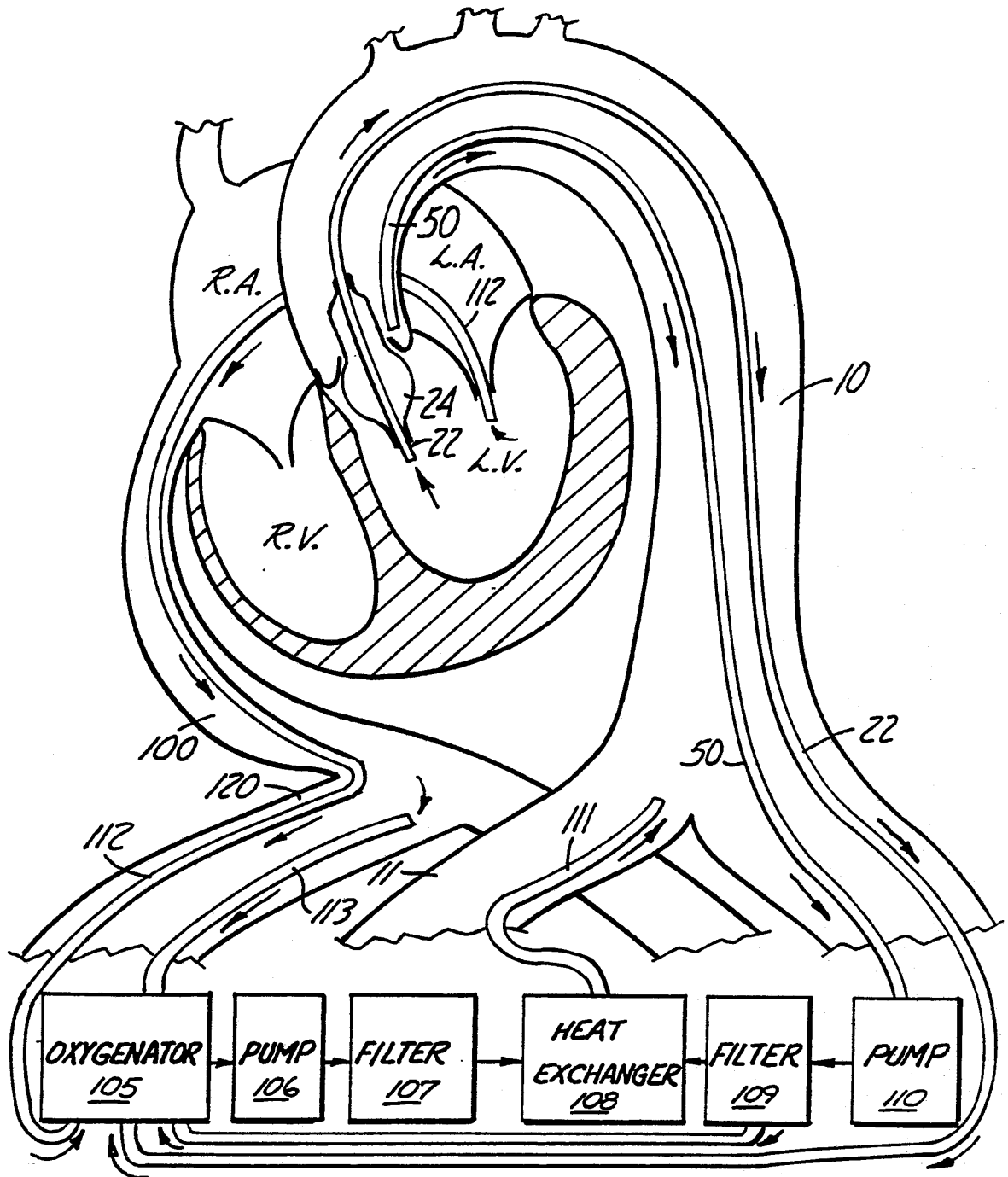


Fig. 20



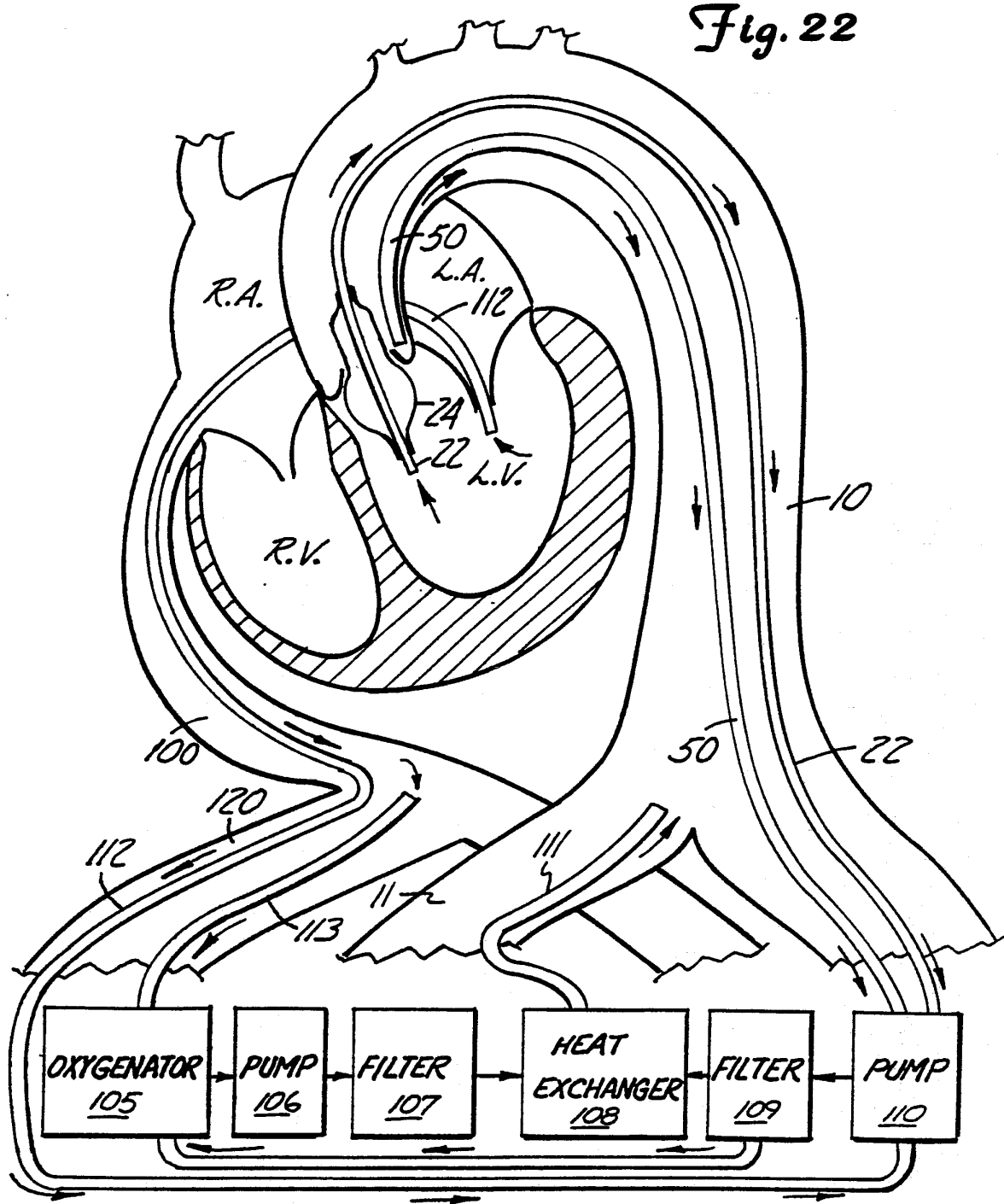
SUBSTITUTE SHEET

Fig. 21



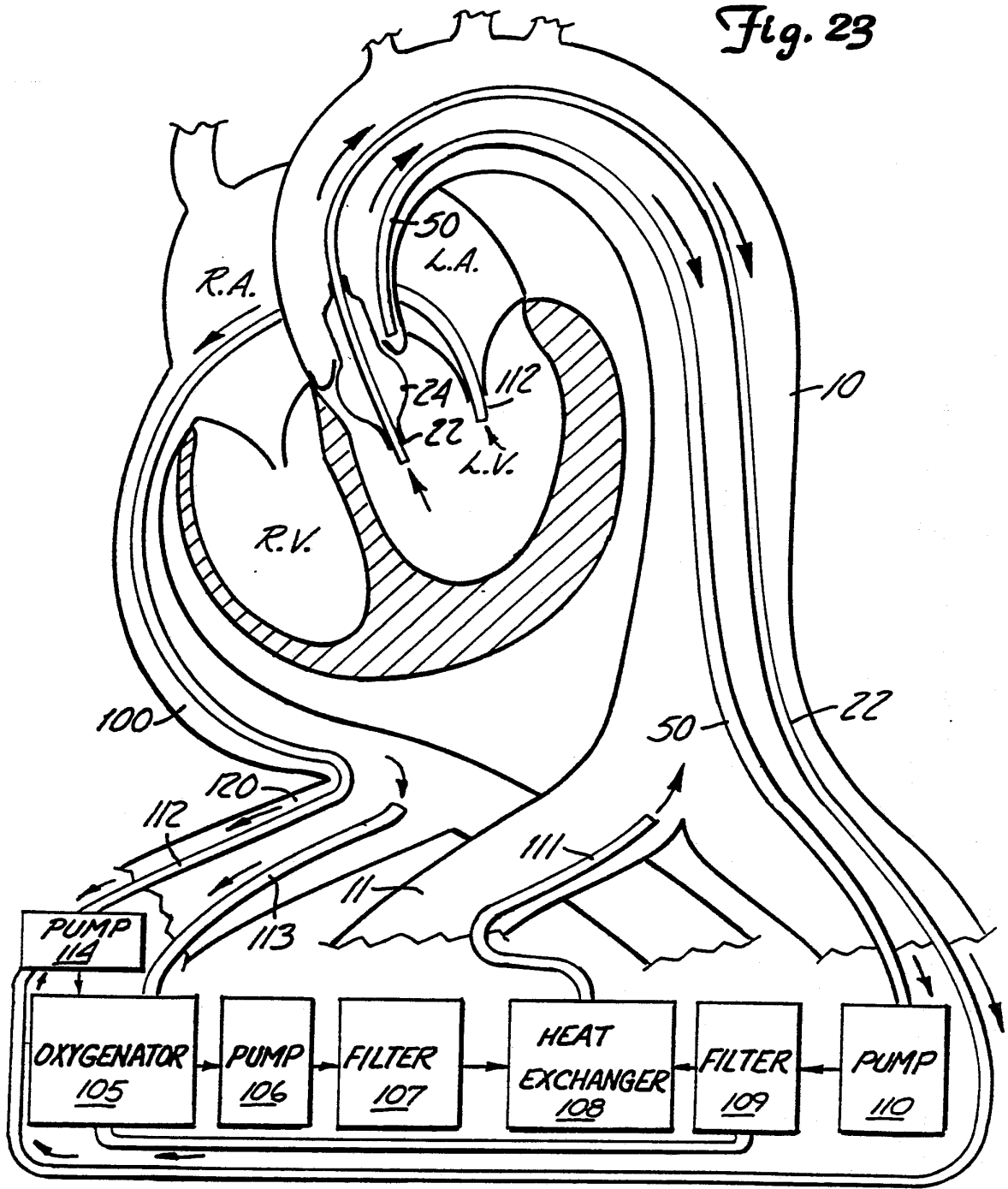
SUBSTITUTE SHEET

Fig. 22



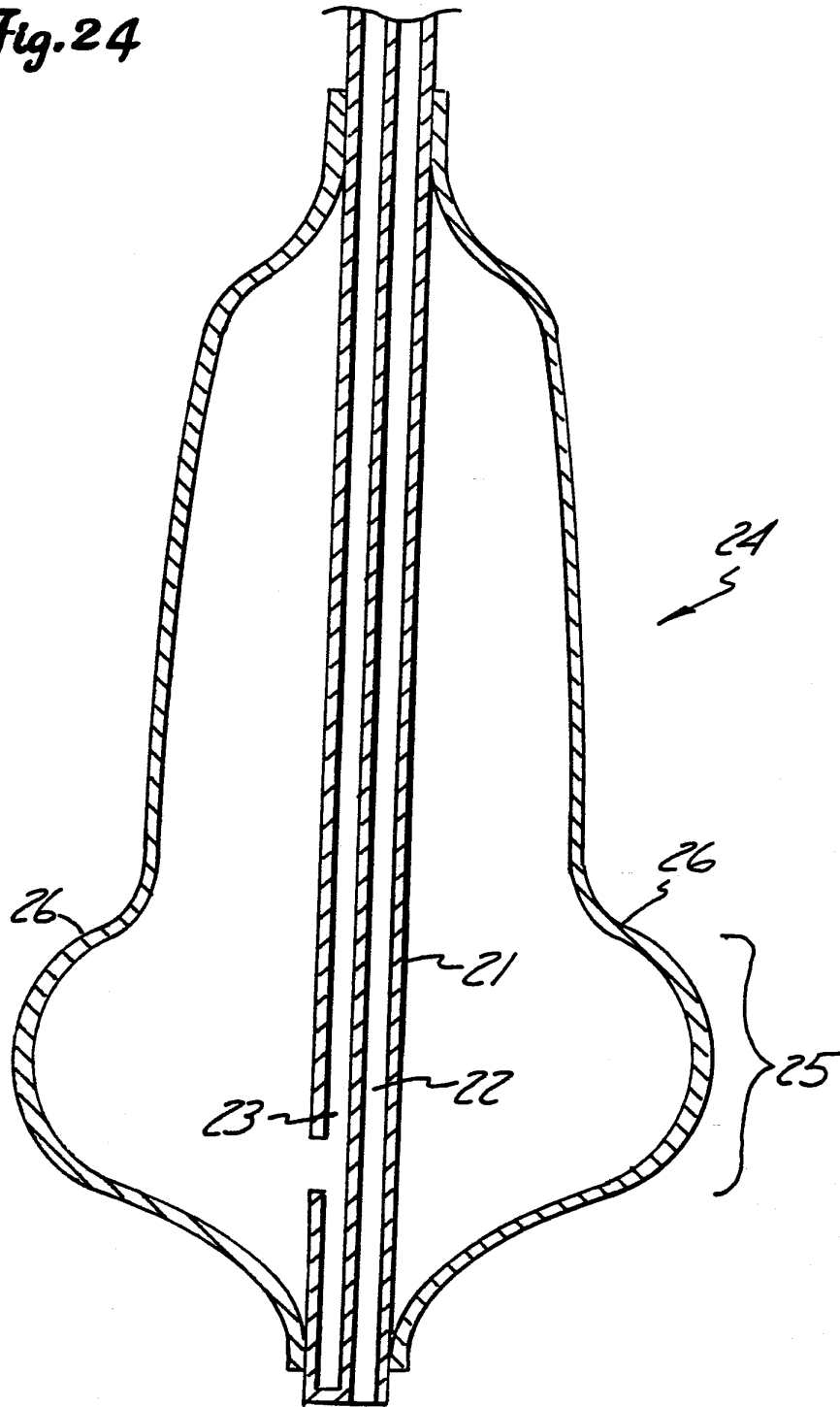
SUBSTITUTE SHEET

Fig. 23



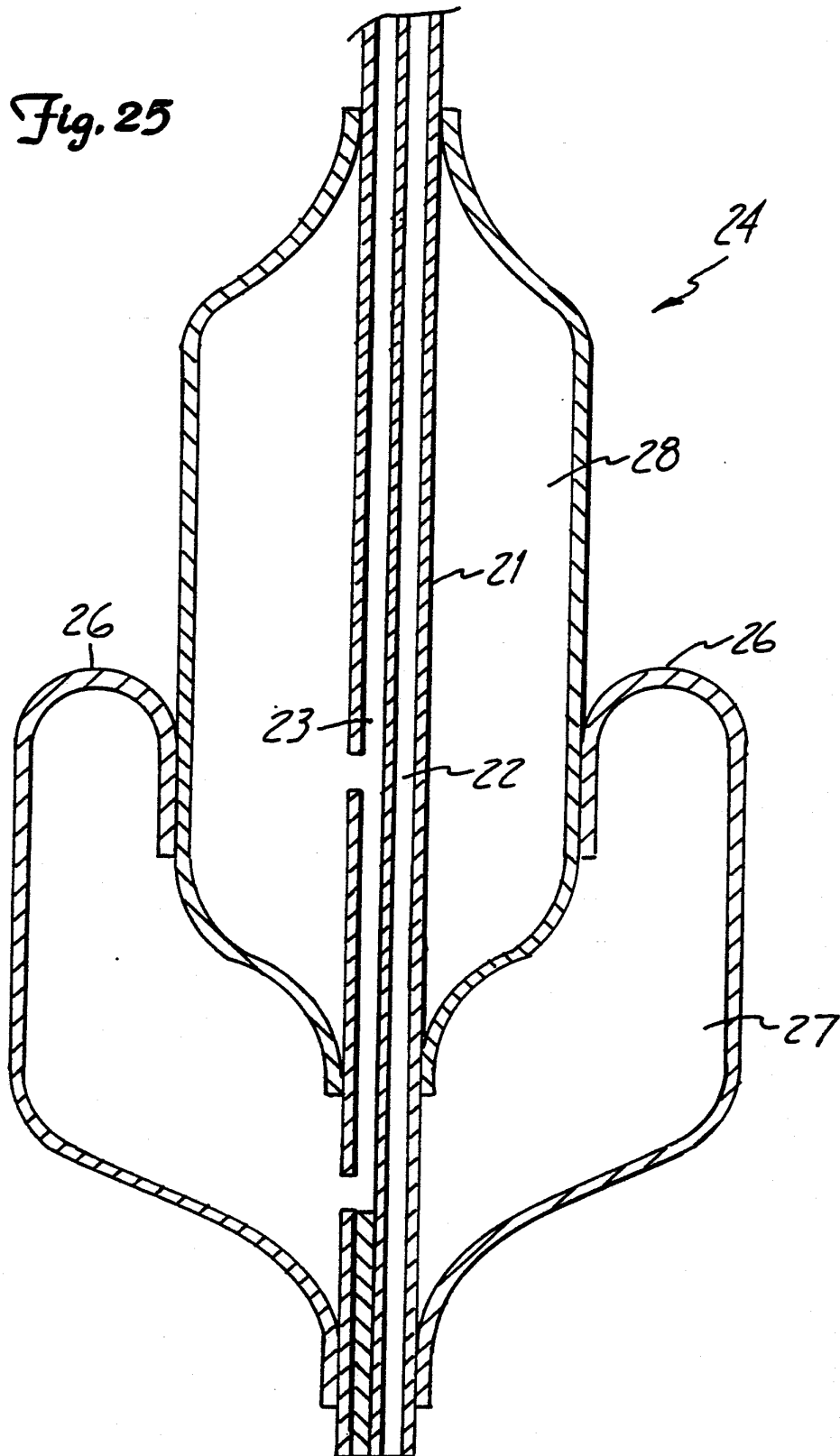
SUBSTITUTE SHEET

*Fig. 24*

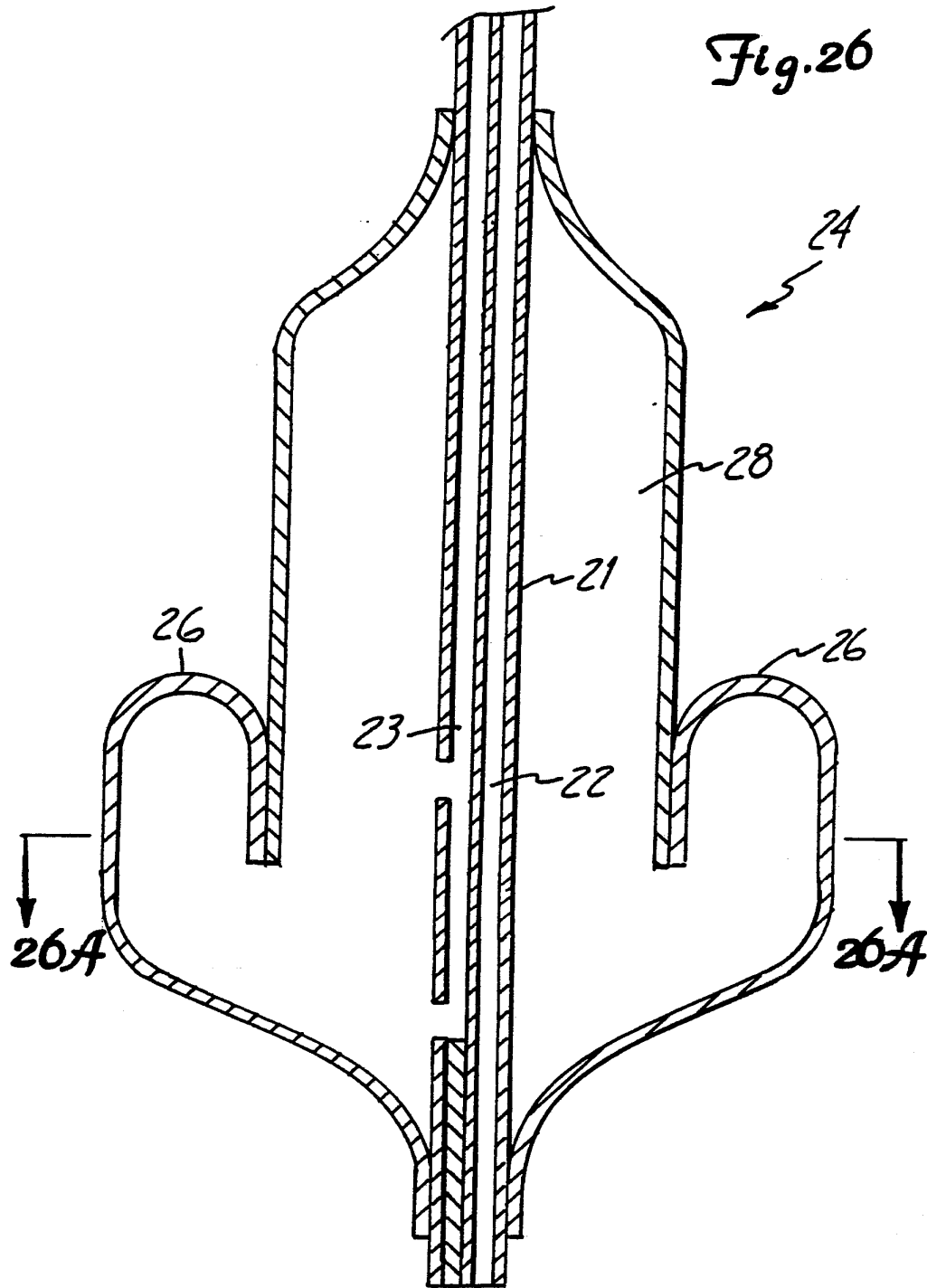


SUBSTITUTE SHEET

Fig. 25

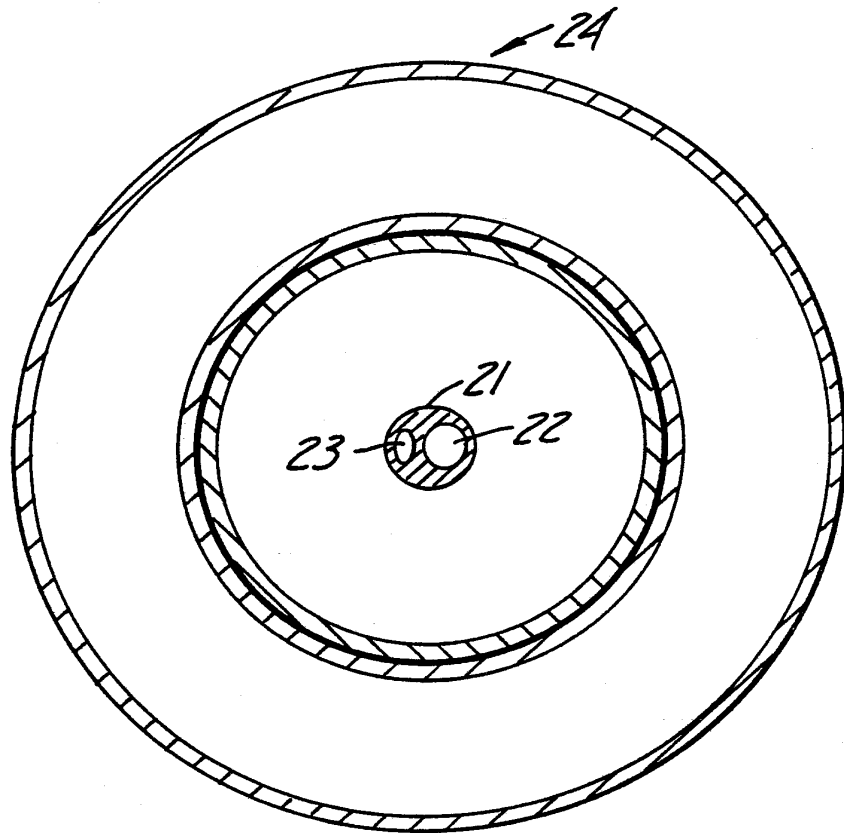


SUBSTITUTE SHEET



SUBSTITUTE SHEET

Fig. 26A



SUBSTITUTE SHEET



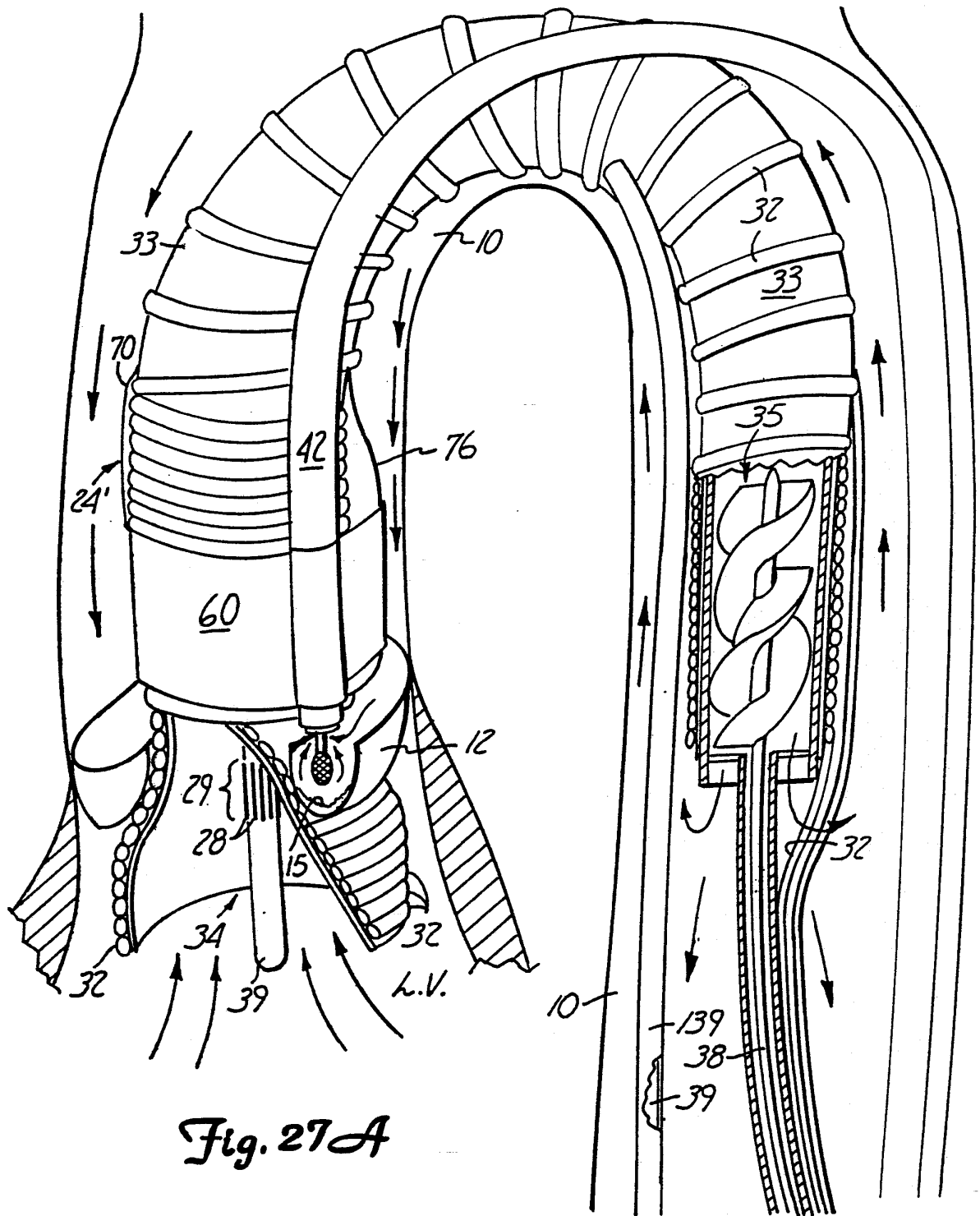


Fig. 27A

SUBSTITUTE SHEET

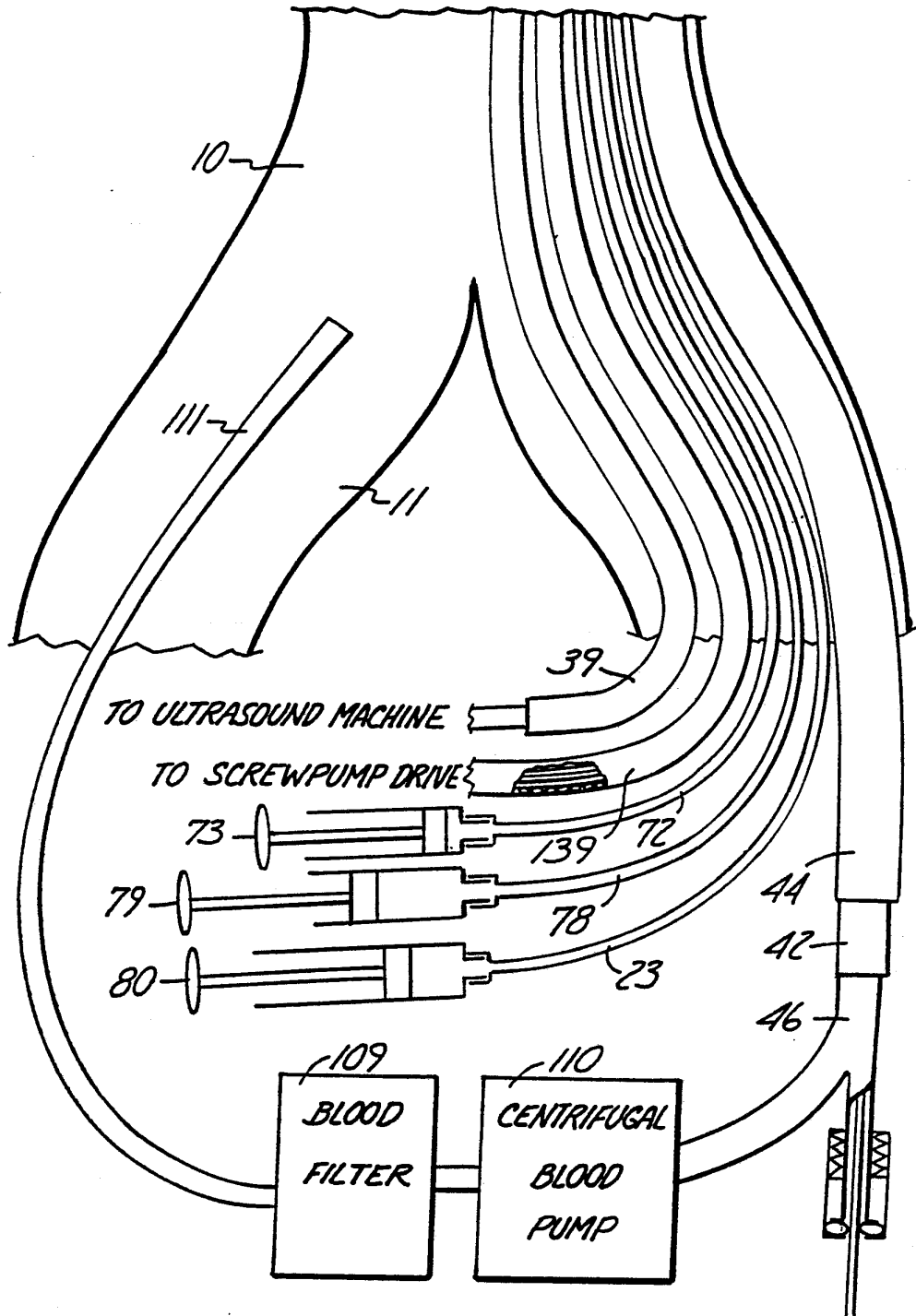


Fig. 27B

SUBSTITUTE SHEET

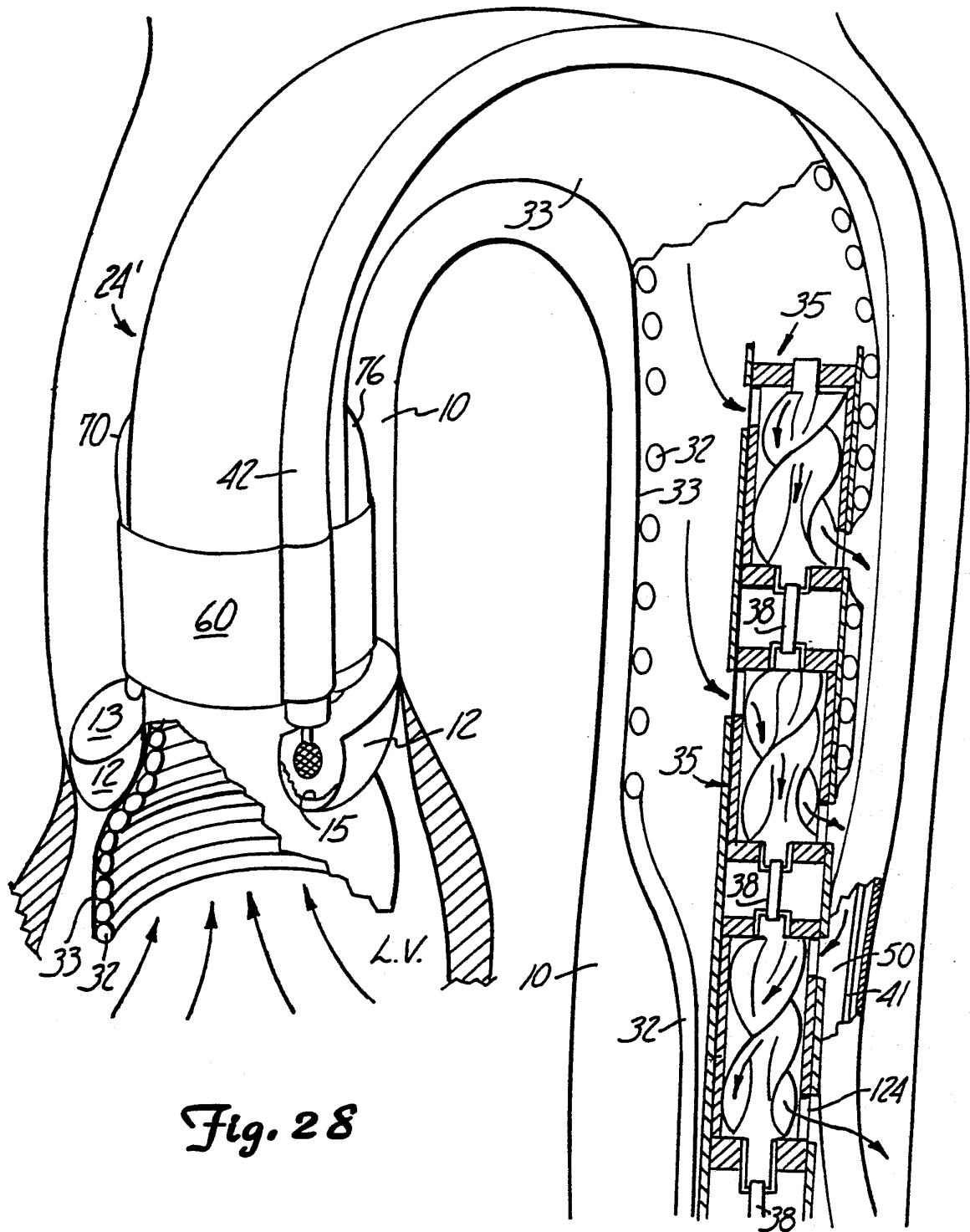


Fig. 28

SUBSTITUTE SHEET

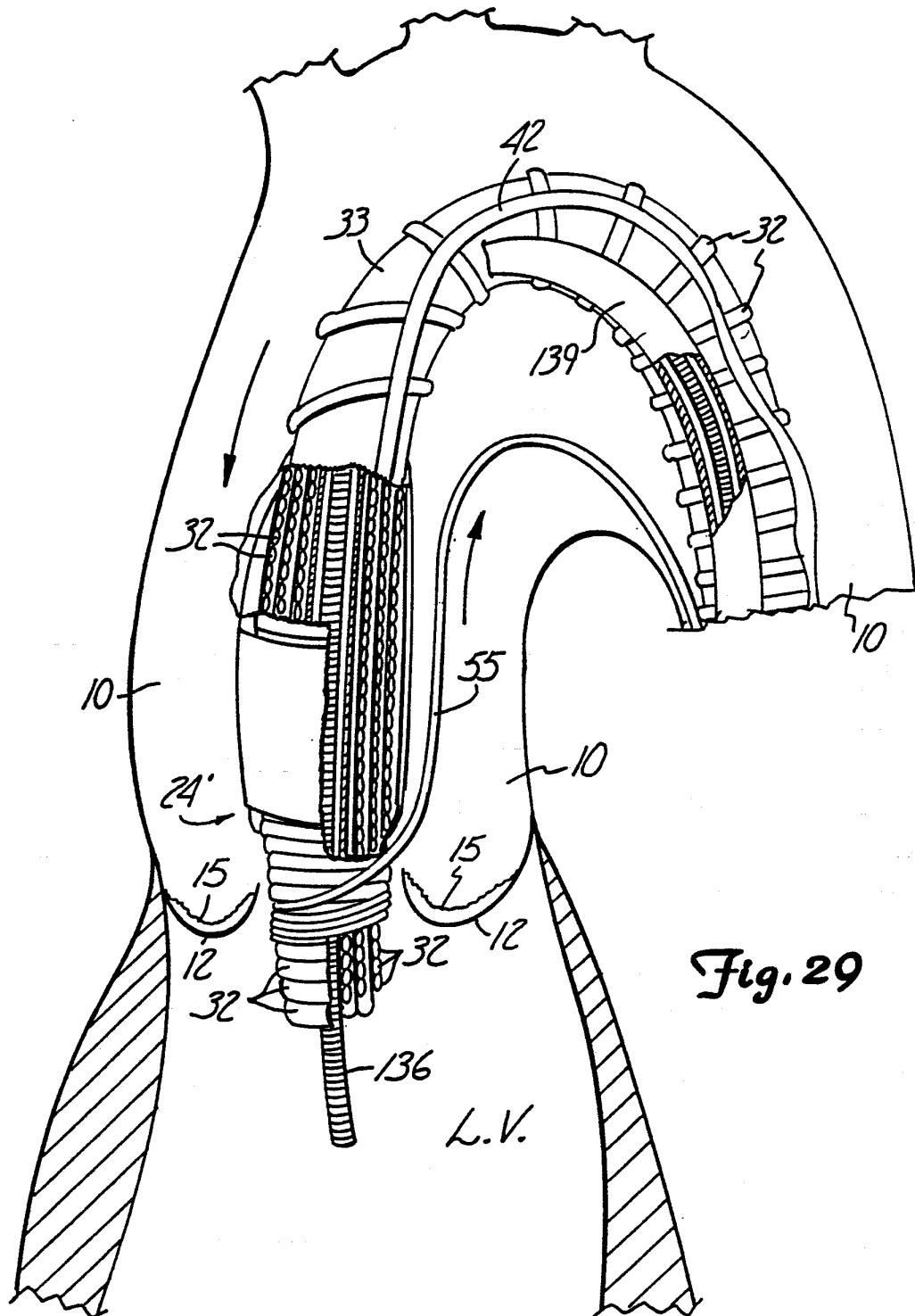


Fig. 29

SUBSTITUTE SHEET

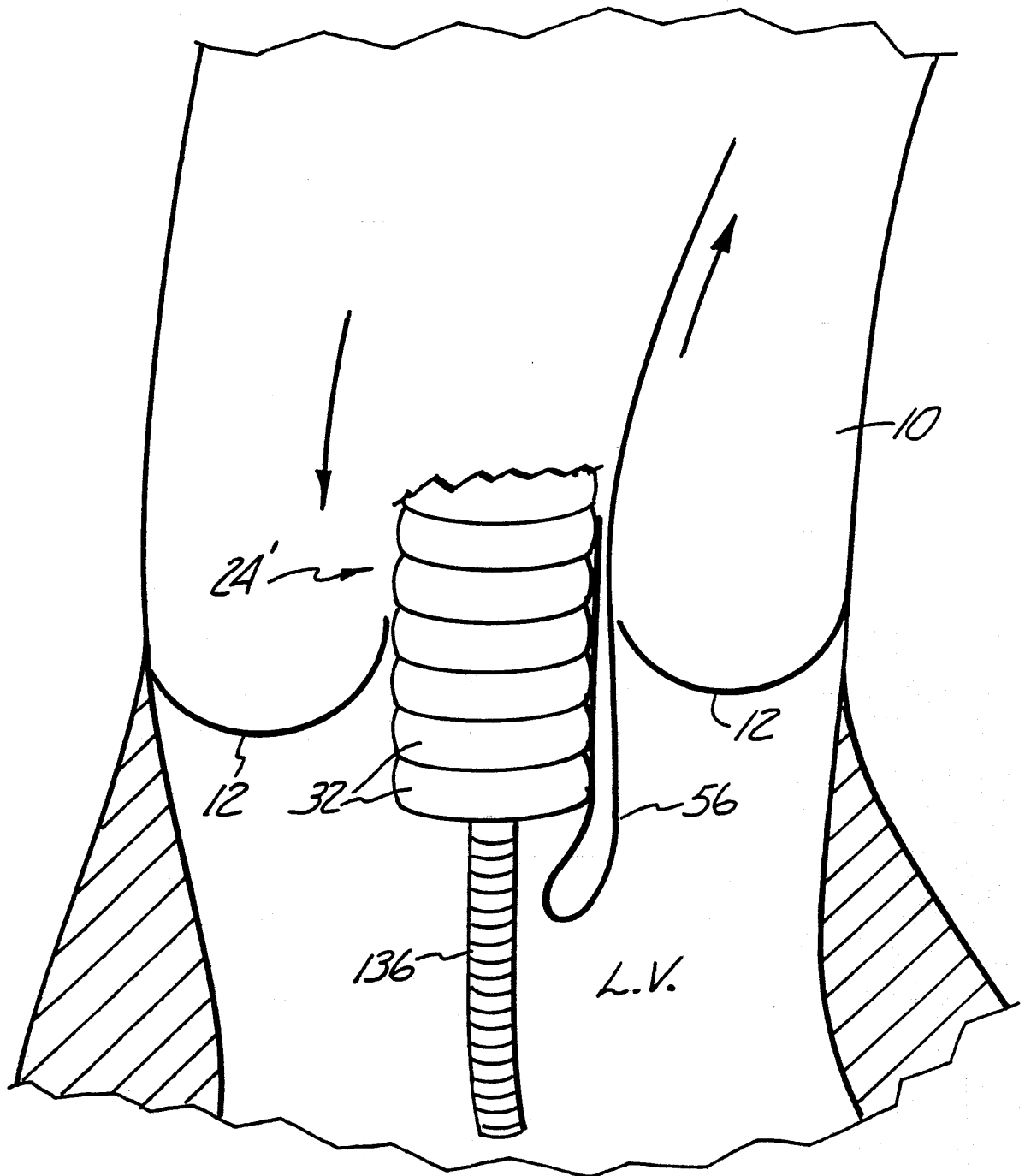
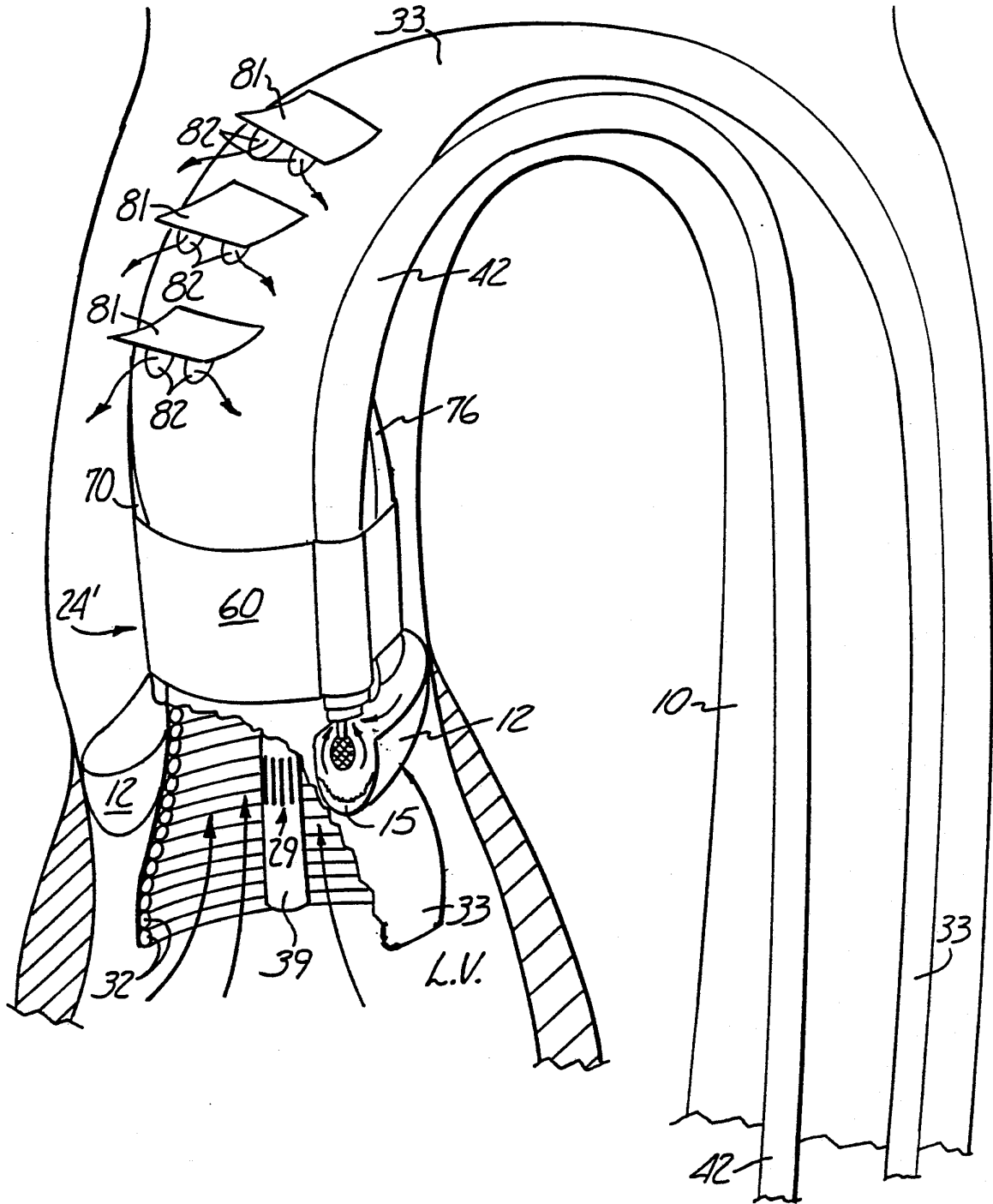


Fig. 30

SUBSTITUTE SHEET

Fig. 31



SUBSTITUTE SHEET

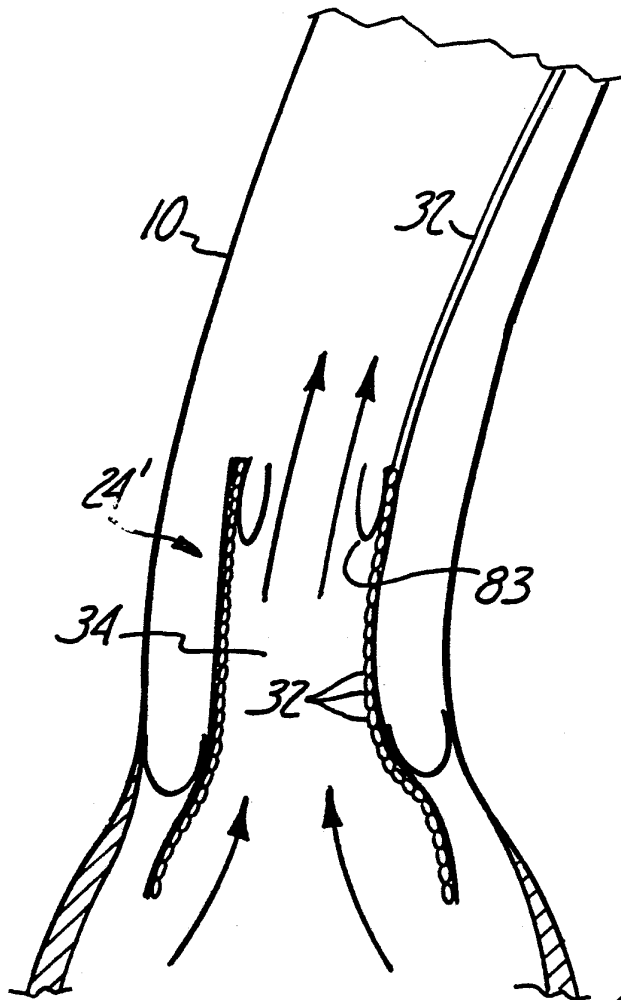


Fig. 32 A

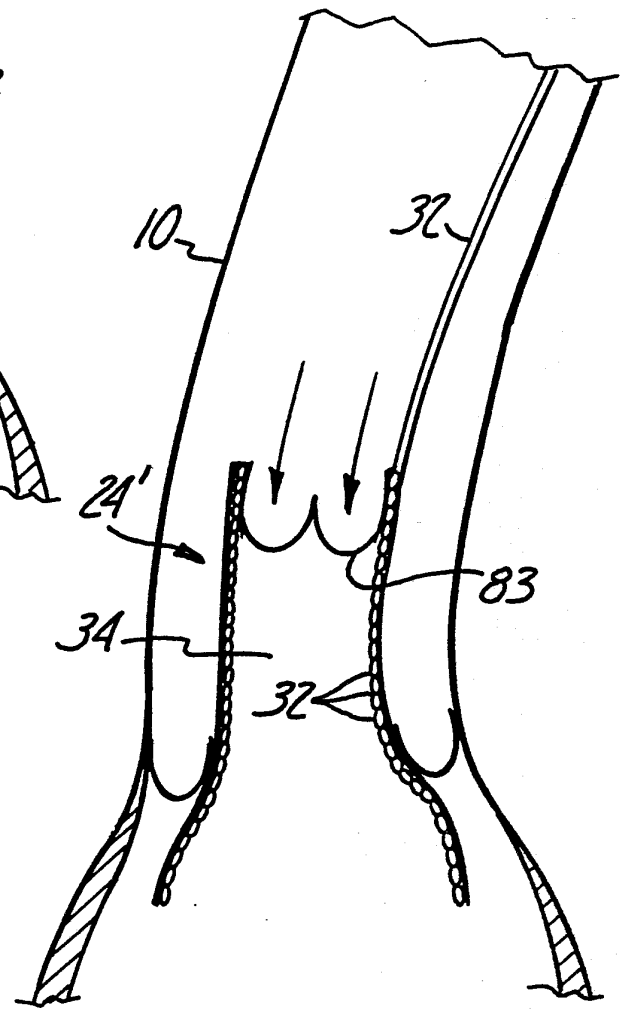


Fig. 32 B

SUBSTITUTE SHEET

34/36

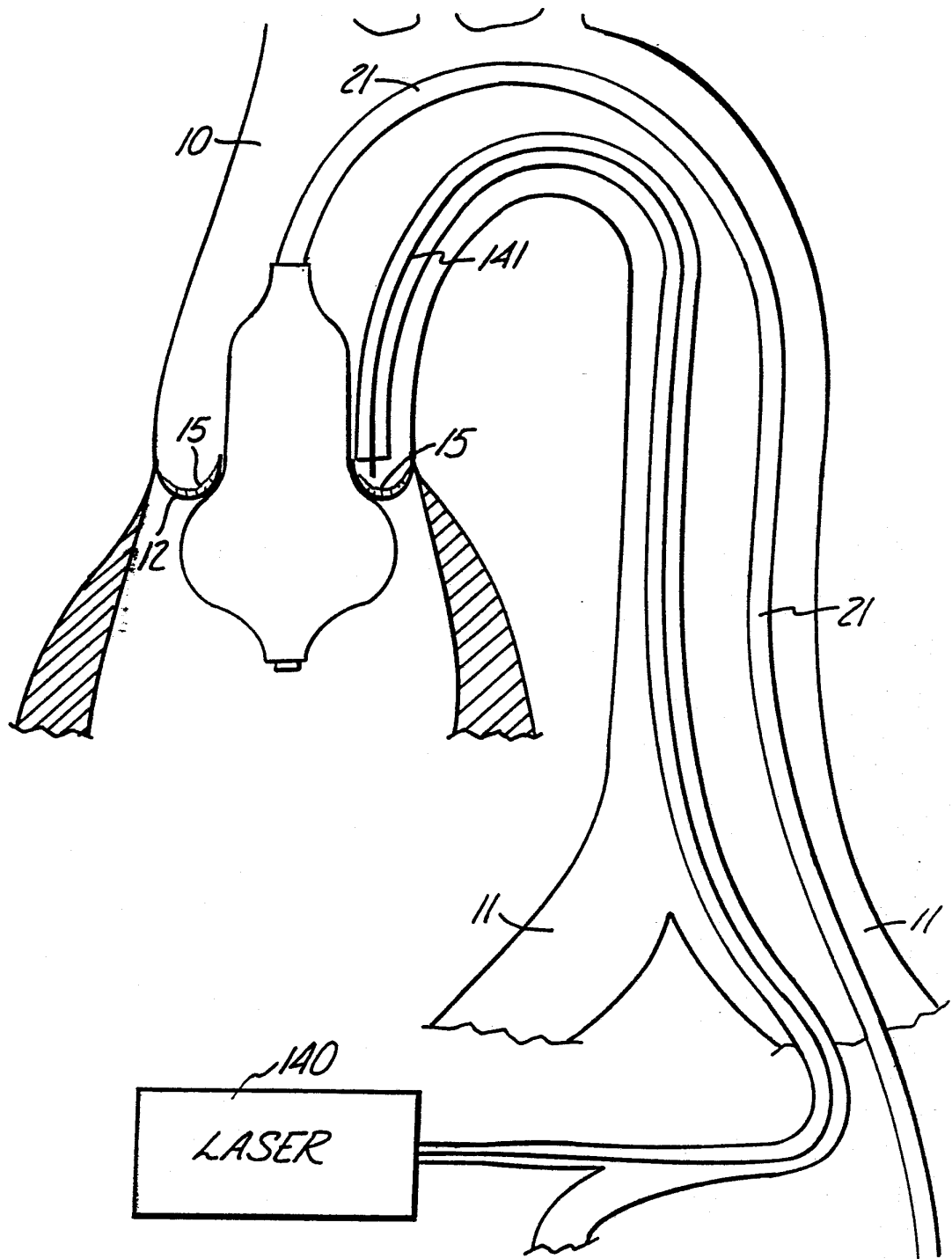
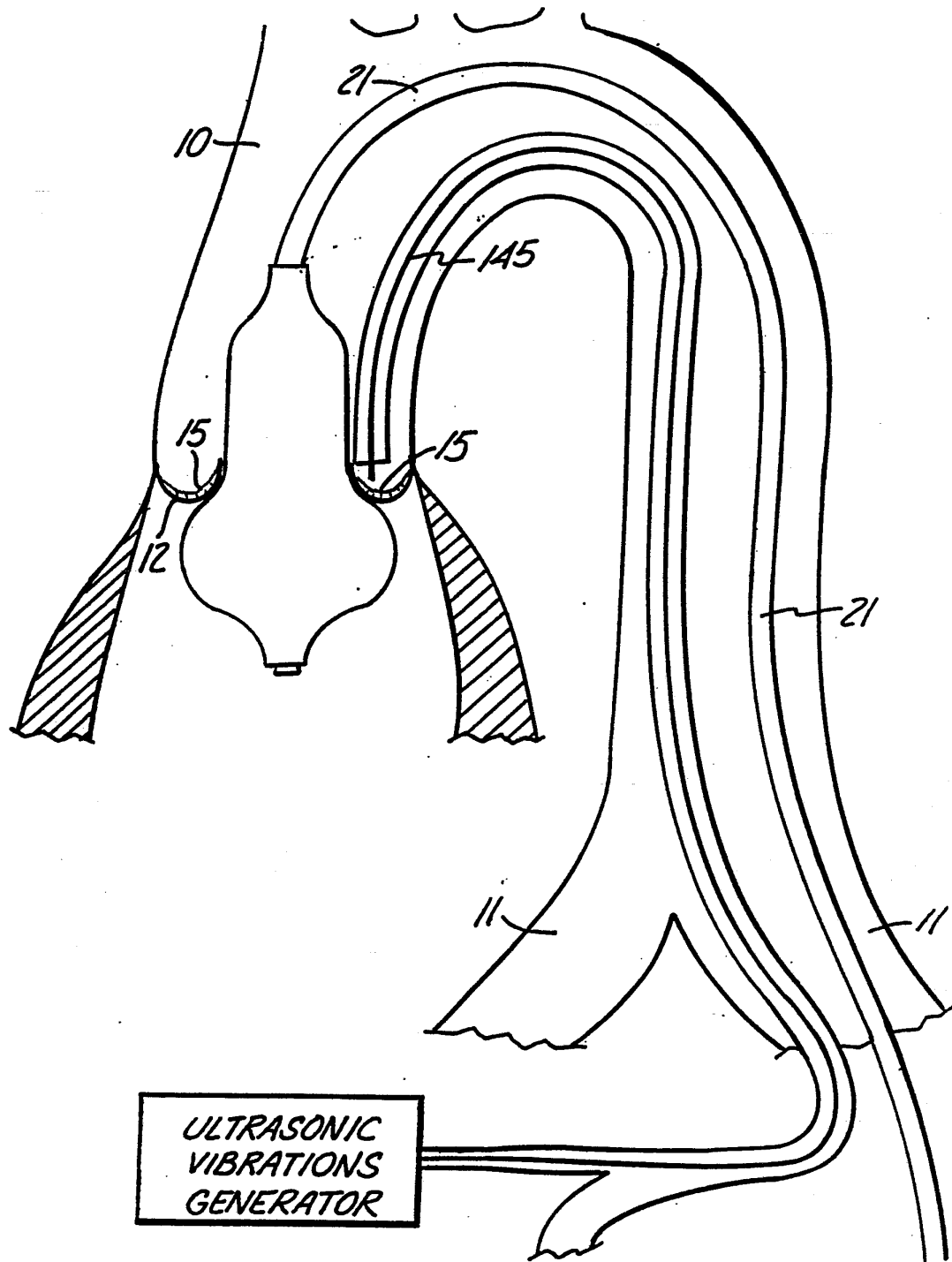


Fig. 33

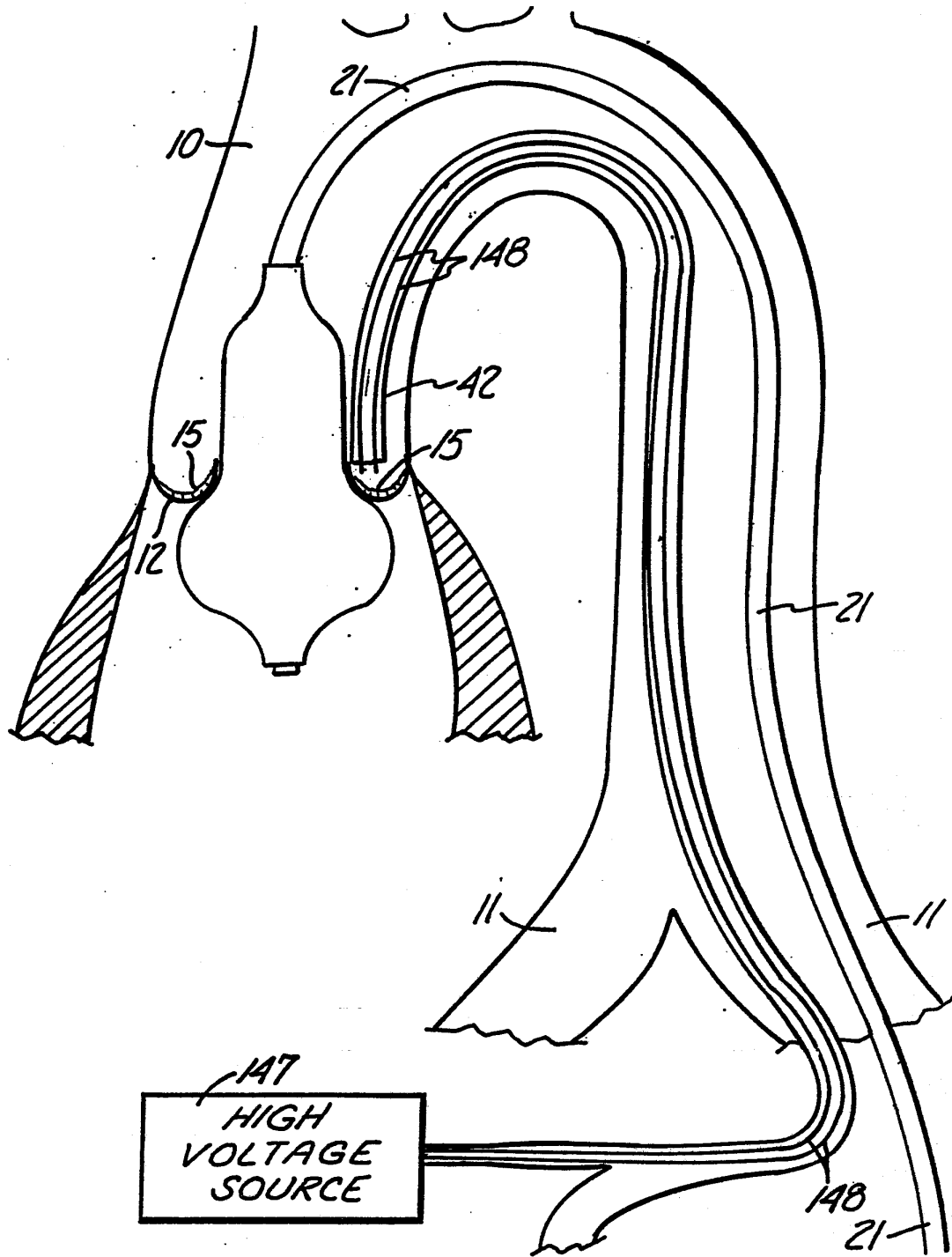
SUBSTITUTE SHEET





**Fig. 34**

SUBSTITUTE SHEET



**Fig. 35**

SUBSTITUTE SHEET

INTERNATIONAL SEARCH REPORT

International application No.  
PCT/US92/02599

**A. CLASSIFICATION OF SUBJECT MATTER**  
 IPC(5) :A61B 17/20; A61M 31/00,29/00; A61D 1/02  
 US CL :604/96,22,53; 606/159; 606/194  
 According to International Patent Classification (IPC) or to both national classification and IPC

**B. FIELDS SEARCHED**  
 Minimum documentation searched (classification system followed by classification symbols)  
 U.S. : 604/95,97-99,101,103,104,113,128,171,173,264,280,283,  
 604/28,49-52; 606/160,167-171,180,191-192  
 Documentation searched other than minimum documentation to the extent that such documents are included in the fields searched

Electronic data base consulted during the international search (name of data base and, where practicable, search terms used)  
 NONE

**C. DOCUMENTS CONSIDERED TO BE RELEVANT**

Category*	Citation of document, with indication, where appropriate, of the relevant passages	Relevant to claim No.
	See Attached Sheet.	

Further documents are listed in the continuation of Box C.  See patent family annex.

* Special categories of cited documents:	*T* later document published after the international filing date or priority date and not in conflict with the application but cited to understand the principle or theory underlying the invention
*A* document defining the general state of the art which is not considered to be part of particular relevance	*X* document of particular relevance; the claimed invention cannot be considered novel or cannot be considered to involve an inventive step when the document is taken alone
*E* earlier document published on or after the international filing date	*Y* document of particular relevance; the claimed invention cannot be considered to involve an inventive step when the document is combined with one or more other such documents, such combination being obvious to a person skilled in the art
*L* document which may throw doubts on priority claim(s) or which is cited to establish the publication date of another citation or other special reason (as specified)	*Z* document member of the same patent family
*O* document referring to an oral disclosure, use, exhibition or other means	
*P* document published prior to the international filing date but later than the priority date claimed	

Date of the actual completion of the international search 16 JULY 1992	Date of mailing of the international search report 5 SEP 1992
---	--

Name and mailing address of the ISA/ Commissioner of Patents and Trademarks Box PCT Washington, D.C. 20231 Facsimile No. NOT APPLICABLE	Authorized officer RONALD STRIGHT, JR. Telephone No. (703) 308-2113
---	---

INTERNATIONAL SEARCH REPORT

International application No.  
PCT/US92/02599

C (Continuation). DOCUMENTS CONSIDERED TO BE RELEVANT		
Category*	Citation of document, with indication, where appropriate, of the relevant passages	Relevant to claim No.
X,P	US,A 5,009,659 (HAMLIN ET AL) 23 APRIL 1991 (SEE ENTIRE DOCUMENT)	1-3,10,12-15,43,54
X	US,A 4,894,051 (SHIBER) 16 JANUARY 1990 (SEE COL. 6, LINES 8-10)	1-3, 10, 12,14-18
X	US,A 4,979,951 (SIMPSON) 25 DECEMBER 1990 (SEE ENTIRE DOCUMENT)	1-3, 10, 12, 14
X,P	US,A 5,092,873 (SIMPSON ET AL) 03 MARCH 1992 (SEE ENTIRE DOCUMENT)	1-3, 10, 12, 14, 23-24
X,E	US,A 5,100,424 (JANG ET AL) 31 MARCH 1992 (SEE ENTIRE DOCUMENT)	1-3, 10, 12, 15, 37, 40, 41
X	US,A 4,784,636 (RYDELL) 15 NOVEMBER 1988 (SEE ENTIRE DOCUMENT)	1-3, 10, 12-14 43, 54
A,P	US,A 5,078,722 (STEVENS) 07 JANUARY 1992 (SEE ENTIRE DOCUMENT)	50-53
A	PROGRESS IN CARDIOLOGY, JULY 1990, (SHAWL ET AL), PERCUTANEOUS CARDIOPULMONARY BYPASS SUPPORT IN THE CATHETERIZATION LABORATORY: TECHNIQUE AND COMPLICATIONS, PP. 195-203.	29-36
<del>X</del> A	INTERNATIONAL JOURNAL OF CARDIAC IMAGING, VOLUMN 4, NOS. 2-4 1989, (BOM ET AL), EARLY AND RECENT INTRALUMINAL ULTRASOUND DEVICES, PP. 79-88. (SEE ENTIRE DOCUMENT)	<u>1-13, 12, 14,37,40,41</u> 38-39
A	US,A 4,785,795 (SINGH) 22 NOVEMBER 1988 (SEE FIGURES 3 AND 4)	23,24
A	US,A 4,762,130 (FOGARTY ET AL) 09 AUGUST 1988 (SEE ENTIRE DOCUMENT)	27,28,44,45
A	US,A 3,438,375 (ERICSON) 15 APRIL 1969 (SEE ENTIRE DOCUMENT)	27,28,44,45
X,P	US,A 5,026,367 (LECKRONE ET AL) 25 JUNE 1991 (SEE ENTIRE DOCUMENT)	1-3,18

Form PCT/ISA/210 (continuation of second sheet)(July 1992)\*



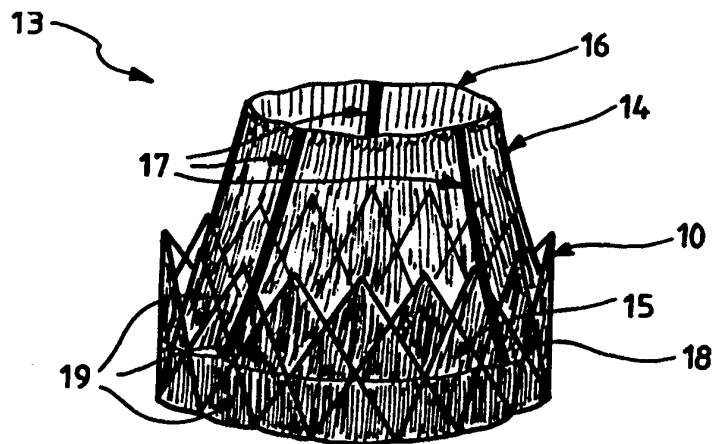
INTERNATIONAL APPLICATION PUBLISHED UNDER THE PATENT COOPERATION TREATY (PCT)

<p>(51) International Patent Classification <sup>6</sup> : <b>A61F 2/24</b></p>	<p>A1</p>	<p>(11) International Publication Number: <b>WO 98/29057</b> (43) International Publication Date: 9 July 1998 (09.07.98)</p>
<p>(21) International Application Number: PCT/EP97/07337 (22) International Filing Date: 31 December 1997 (31.12.97) (30) Priority Data: 96402929.2 31 December 1996 (31.12.96) EP (34) Countries for which the regional or international application was filed: GB et al. (71) Applicant (for all designated States except US): CORDIS CORPORATION [US/US]; 40 Technology Drive, Warren, NJ 07059 (US). (72) Inventors; and (75) Inventors/Applicants (for US only): LETAC, Brice [FR/FR]; 15, allée de la Cédraie, F-76130 Mont-Saint-Aignan (FR). CRIBIER, Alain [FR/FR]; 2, rue Alain, F-76150 Maromme (FR). (74) Agents: GUTMAN, Ernest et al.; Ernest Gutman - Yves Plasseraud S.A., 3, rue Chauveau-Lagarde, F-75008 Paris (FR).</p>		<p>(81) Designated States: AL, AM, AT, AU, AZ, BA, BB, BG, BR, BY, CA, CH, CN, CU, CZ, DE, DK, EE, ES, FI, GB, GE, GH, GM, GW, HU, IL, IS, JP, KE, KG, KP, KR, KZ, LC, LK, LR, LS, LT, LU, LV, MD, MG, MK, MN, MW, MX, NO, NZ, PL, PT, RO, RU, SD, SE, SG, SI, SK, SL, TJ, TM, TR, TT, UA, UG, US, UZ, VN, YU, ZW, ARIPO patent (GH, GM, KE, LS, MW, SD, SZ, UG, ZW), Eurasian patent (AM, AZ, BY, KG, KZ, MD, RU, TJ, TM), European patent (AT, BE, CH, DE, DK, ES, FI, FR, GB, GR, IE, IT, LU, MC, NL, PT, SE), OAPI patent (BF, BJ, CF, CG, CI, CM, GA, GN, ML, MR, NE, SN, TD, TG).</p> <p><b>Published</b> <i>With international search report. Before the expiration of the time limit for amending the claims and to be republished in the event of the receipt of amendments.</i></p>

(54) Title: VALVE PROSTHESIS FOR IMPLANTATION IN BODY CHANNELS

(57) Abstract

The present invention is aimed to provide a valve prosthesis (IV) especially used in case of aortic stenosis, which structure is capable of resisting the powerful recoil force and to stand the forceful balloon inflation performed to deploy the valve and to embed it in the aortic annulus. A valve prosthesis (13) for implantation in a body channel according to the invention comprises a collapsible valvular structure (14) and an expandable frame (10, 10') on which said valvular structure (14) is mounted. The valvular structure (14) is composed of a valvular tissue compatible with the human body and blood, the valvular tissue being sufficiently supple and resistant to allow said valvular structure (14) to be deformed from a closed state to an opened state. Said valvular tissue forms a continuous surface and is provided with guiding means (17) formed or incorporated within, said guiding means creating stiffened zones which induce said valvular structure (14) to follow a patterned movement in its expansion to its opened state and in its turning back to its closed state. The valvular structure can be extended to an internal cover (19) which is fastened to the lower end (15) of the valvular structure to prevent from regurgitation.



**FOR THE PURPOSES OF INFORMATION ONLY**

Codes used to identify States party to the PCT on the front pages of pamphlets publishing international applications under the PCT.

<b>AL</b>	Albania	<b>ES</b>	Spain	<b>LS</b>	Lesotho	<b>SI</b>	Slovenia
<b>AM</b>	Armenia	<b>FI</b>	Finland	<b>LT</b>	Lithuania	<b>SK</b>	Slovakia
<b>AT</b>	Austria	<b>FR</b>	France	<b>LU</b>	Luxembourg	<b>SN</b>	Senegal
<b>AU</b>	Australia	<b>GA</b>	Gabon	<b>LV</b>	Latvia	<b>SZ</b>	Swaziland
<b>AZ</b>	Azerbaijan	<b>GB</b>	United Kingdom	<b>MC</b>	Monaco	<b>TD</b>	Chad
<b>BA</b>	Bosnia and Herzegovina	<b>GE</b>	Georgia	<b>MD</b>	Republic of Moldova	<b>TG</b>	Togo
<b>BB</b>	Barbados	<b>GH</b>	Ghana	<b>MG</b>	Madagascar	<b>TJ</b>	Tajikistan
<b>BE</b>	Belgium	<b>GN</b>	Guinea	<b>MK</b>	The former Yugoslav Republic of Macedonia	<b>TM</b>	Turkmenistan
<b>BF</b>	Burkina Faso	<b>GR</b>	Greece			<b>TR</b>	Turkey
<b>BG</b>	Bulgaria	<b>HU</b>	Hungary	<b>ML</b>	Mali	<b>TT</b>	Trinidad and Tobago
<b>BJ</b>	Benin	<b>IE</b>	Ireland	<b>MN</b>	Mongolia	<b>UA</b>	Ukraine
<b>BR</b>	Brazil	<b>IL</b>	Israel	<b>MR</b>	Mauritania	<b>UG</b>	Uganda
<b>BY</b>	Belarus	<b>IS</b>	Iceland	<b>MW</b>	Malawi	<b>US</b>	United States of America
<b>CA</b>	Canada	<b>IT</b>	Italy	<b>MX</b>	Mexico	<b>UZ</b>	Uzbekistan
<b>CF</b>	Central African Republic	<b>JP</b>	Japan	<b>NE</b>	Niger	<b>VN</b>	Viet Nam
<b>CG</b>	Congo	<b>KE</b>	Kenya	<b>NL</b>	Netherlands	<b>YU</b>	Yugoslavia
<b>CH</b>	Switzerland	<b>KG</b>	Kyrgyzstan	<b>NO</b>	Norway	<b>ZW</b>	Zimbabwe
<b>CI</b>	Côte d'Ivoire	<b>KP</b>	Democratic People's Republic of Korea	<b>NZ</b>	New Zealand		
<b>CM</b>	Cameroon			<b>PL</b>	Poland		
<b>CN</b>	China	<b>KR</b>	Republic of Korea	<b>PT</b>	Portugal		
<b>CU</b>	Cuba	<b>KZ</b>	Kazakstan	<b>RO</b>	Romania		
<b>CZ</b>	Czech Republic	<b>LC</b>	Saint Lucia	<b>RU</b>	Russian Federation		
<b>DE</b>	Germany	<b>LI</b>	Liechtenstein	<b>SD</b>	Sudan		
<b>DK</b>	Denmark	<b>LK</b>	Sri Lanka	<b>SE</b>	Sweden		
<b>EE</b>	Estonia	<b>LR</b>	Liberia	<b>SG</b>	Singapore		

VALVE PROSTHESIS FOR IMPLANTATION IN BODY  
CHANNELS

The present invention relates to a valve prosthesis for implantation  
5 in body channels, more particularly but not only to, cardiac valve prosthesis  
to be implanted by a transcatheterization technique.

The valve prosthesis can be also applied to other body channels  
provided with native valves, such as veins or in organs (liver, intestine,  
urethra,...).

10 The present invention also relates to a method for implanting a  
valve prosthesis, such as the valve according to the present invention.

Implantable valves, which will be indifferently designated hereafter  
as "IV", "valve prosthesis" or "prosthetic valve", permits the reparation of a  
valvular defect by a less invasive technique in place of the usual surgical  
15 valve implantation which, in the case of valvular heart diseases, requires  
thoracotomy and extracorporeal circulation. A particular use for the IV  
concerns patients who cannot be operated on because of an associated  
disease or because of very old age or also patients who could be operated  
on but only at a very high risk.

20 Although the IV of the present invention and the process for  
implanting said IV can be used in various heart valve diseases, the  
following description will first concern the aortic orifice in aortic stenosis,  
more particularly in its degenerative form in elderly patients.

Aortic stenosis is a disease of the aortic valve in the left ventricle of  
25 the heart. The aortic valvular orifice is normally capable of opening during  
systole up to 4 to 6 cm<sup>2</sup>, therefore allowing free ejection of the ventricular  
blood volume into the aorta. This aortic valvular orifice can become tightly  
stenosed, and therefore the blood cannot anymore be freely ejected from  
the left ventricle. In fact, only a reduced amount of blood can be ejected by  
30 the left ventricle which has to markedly increase the intra-cavitary pressure

**CONFIRMATION COPY**

to force the stenosed aortic orifice. In such aortic diseases, the patients can have syncope, chest pain, and mainly difficulty in breathing. The evolution of such a disease is disastrous when symptoms of cardiac failure appear, since 50 % of the patients die in the year following the first symptoms of the disease.

The only commonly available treatment is the replacement of the stenosed aortic valve by a prosthetic valve via surgery: this treatment moreover providing excellent results. If surgery is impossible to perform, i.e., if the patient is deemed inoperable or operable only at a too high surgical risk, an alternative possibility is to dilate the valve with a balloon catheter to enlarge the aortic orifice. Unfortunately, a good result is obtained only in about half of the cases and there is a high restenosis rate, i.e., about 80% after one year.

Aortic stenosis is a very common disease in people above seventy years old and occurs more and more frequently as the subject gets older. As evidenced, the present tendency of the general evolution of the population is becoming older and older. Also, it can be evaluated, as a crude estimation, that about 30 to 50% of the subjects who are older than 80 years and have a tight aortic stenosis, either cannot be operated on for aortic valve replacement with a reasonable surgical risk or even cannot be considered at all for surgery.

It can be estimated that, about 30 to 40 persons out of a million per year, could benefit from an implantable aortic valve positioned by a catheterization technique. Until now, the implantation of a valve prosthesis for the treatment of aortic stenosis is considered unrealistic to perform since it is deemed difficult to superpose another valve such an implantable valve on the distorted stenosed native valve without excising the latter.

From 1985, the technique of aortic valvuloplasty with a balloon catheter has been introduced for the treatment of subjects in whom surgery cannot be performed at all or which could be performed only with a



prohibitive surgical risk. Despite the considerable deformation of the stenosed aortic valve, commonly with marked calcification, it is often possible to enlarge significantly the aortic orifice by balloon inflation, a procedure which is considered as low risk.

5           However, this technique has been abandoned by most physicians because of the very high restenosis rate which occurs in about 80% of the patients within 10 to 12 months. Indeed, immediately after deflation of the balloon, a strong recoil phenomenon often produces a loss of half or even two thirds of the opening area obtained by the inflated balloon. For  
10 instance, inflation of a 20 mm diameter balloon in a stenosed aortic orifice of 0.5 cm<sup>2</sup> area gives, when forcefully and fully inflated, an opening area equal to the cross sectionnal area of the maximally inflated balloon, i.e., about 3 cm<sup>2</sup>. However, measurements performed a few minutes after  
15 deflation and removal of the balloon have only an area around 1 cm<sup>2</sup> to 1.2 cm<sup>2</sup>. This is due to the considerable recoil of the fibrous tissue of the diseased valve. The drawback in this procedure has also been clearly shown on fresh post mortem specimens.

          However, it is important to note that whereas the natural normal aortic valve is able to open with an orifice of about 5 to 6 cm<sup>2</sup> and to  
20 accommodate a blood flow of more than 15 l/min. during heavy exercise for instance, an opening area of about 1.5 to 2 cm<sup>2</sup> can accept a 6 to 8 l/min blood flow without a significant pressure gradient. Such a flow corresponds to the cardiac output of the elderly subject with limited physical activity.

          Therefore, an IV would not have to produce a large opening of the  
25 aortic orifice since an opening about 2 cm<sup>2</sup> would be sufficient in most subjects, in particular in elderly subjects, whose cardiac output probably does not reach more than 6 to 8 l/min. during normal physical activity. For instance, the surgically implanted mechanical valves have an opening area which is far from the natural valve opening that ranges from 2 to 2.5 cm<sup>2</sup>,

mainly because of the room taken by the large circular structure supporting the valvular part of the device.

The prior art describes examples of cardiac valves prosthesis that are aimed at being implanted without surgical intervention by way of catheterization. For instance, US patent n° 5,411,552 describes a  
5 collapsible valve able to be introduced in the body in a compressed presentation and expanded in the right position by balloon inflation.

Such valves, with a semi-lunar leaflet design, tend to imitate the natural valve. However, this type of design is inherently fragile, and such  
10 structures are not strong enough to be used in the case of aortic stenosis because of the strong recoil that will distort this weak structure and because they would not be able to resist the balloon inflation performed to position the implantable valve. Furthermore, this valvular structure is attached to a metallic frame of thin wires that will not be able to be tightly  
15 secured against the valve annulus. The metallic frame of this implantable valve is made of thin wires like in stents, which are implanted in vessels after balloon dilatation. Such a light stent structure is too weak to allow the implantable valve to be forcefully embedded into the aortic annulus. Moreover, there is a high risk of massive regurgitation (during the diastolic  
20 phase) through the spaces between the frame wires which is another prohibitive risk that would make this implantable valve impossible to use in clinical practice.

Furthermore, an important point in view of the development of the IV is that it is possible to maximally inflate a balloon placed inside the  
25 compressed implantable valve to expand it and insert it in the stenosed aortic valve up to about 20 to 23 mm in diameter. At the time of maximum balloon inflation, the balloon is absolutely stiff and cylindrical without any waist. At that moment, the implantable valve is squeezed and crushed between the strong aortic annulus and the rigid balloon with the risk of

causing irreversible damage to the valvular structure of the implantable valve.

#### SUMMARY OF THE INVENTION

The invention is aimed to overcome these drawbacks and to  
5 implant an IV which will remain reliable for years.

A particular aim of the present invention is to provide an IV, especially aimed at being used in case of aortic stenosis, which structure is capable of resisting the powerful recoil force and to stand the forceful balloon inflation performed to deploy the IV and to embed it in the aortic  
10 annulus.

Another aim of the present invention is to provide an efficient prosthesis valve which can be implanted by a catheterization technique, in particular in a stenosed aortic orifice, taking advantage of the strong structure made of the distorted stenosed valve and of the large opening  
15 area produced by preliminary balloon inflation, performed as an initial step of the procedure.

A further aim of the present invention is to provide an implantable valve which would not produce any risk of fluid regurgitation.

A further aim of the present invention is to provide a valve  
20 prosthesis implantation technique using a two-balloon catheter and a two-frame device.

These aims are achieved according to the present invention which provides a valve prosthesis of the type mentioned in the introductory part and wherein said valve prosthesis comprises a collapsible continuous  
25 structure with guiding means providing stiffness and a frame to which said structure is fastened, said frame being strong enough to resist the recoil phenomenon of the fibrous tissue of the diseased valve.

The IV, which is strongly embedded, enables the implantable valve to be maintained in the right position without any risk of further  
30 displacement, which would be a catastrophic event.

More precisely, this valvular structure comprises a valvular tissue compatible with the human body and blood, which is supple and resistant to allow said valvular structure to pass from a closed state to an open state to allow a body fluid, more particularly the blood, exerting pressure on said valvular structure, to flow. The valvular tissue forms a continuous surface and is provided with guiding means formed or incorporated within, creating stiffened zones which induce the valvular structure to follow a patterned movement from its open position to its closed state and vice-versa, providing therefore a structure sufficiently rigid to prevent diversion, in particular into the left ventricle and thus preventing any regurgitation of blood into the left ventricle in case of aortic implantation.

Moreover, the guided structure of the IV of the invention allows the tissue of this structure to open and close with the same patterned movement while occupying as little space as possible in the closed state of the valve. Therefore, owing to these guiding means, the valvular structure withstands the unceasing movements under blood pressure changes during the heart beats.

More preferably, the valvular structure has a substantially truncated hyperboloïdal shape in its expanded position, with a larger base and a growing closer neck, ending in a smaller extremity forming the upper part of the valvular structure. The valvular structure has a curvature at its surface that is concave towards the aortic wall. Such a shape produces a strong and efficient structure in view of the systolo-diastolic movement of the valvular tissue. Such a valvular structure with its simple and regular shape also lowers the risk of being damaged by forceful balloon inflation at the time of IV deployment.

A trunco-hyperboloïdal shape with a small diameter at the upper extremity facilitates the closure of the valve at the beginning of diastole in initiating the starting of the reverse movement of the valvular tissue towards its base. Another advantage of this truncated hyperboloïdal shape is that

the upper extremity of the valvular structure, because of its smaller diameter, remains at a distance from the coronary ostia during systole as well as during diastole, thus offering an additional security to ensure not to impede at all the passage of blood from the aorta to the coronary ostia.

5           As another advantageous embodiment of the invention, the guiding means of the valvular structure are inclined strips from the base to the upper extremity of the valvular structure with regard to the central axis of the valvular structure. This inclination initiates and imparts a general helicoidal movement of the valvular structure around said central axis at the  
10 time of closure or opening of said structure, such a movement enabling to help initiate and finalize the closure of the valvular structure. In particular, this movement improves the collapse of the valvular structure towards its base at the time of diastole and during the reversal of flow at the very beginning of diastole. During diastole, the valvular structure thus falls down,  
15 folding on itself and collapses on its base, therefore closing the aortic orifice. The strips can be pleats, strengthening struts or thickened zones.

In other embodiments, said guiding means are rectilinear strips from the base to the upper extremity of the valvular structure. In this case, the guiding means can comprise pleats, struts or thickened zones. In a  
20 particular embodiment, the stiffened zones then created can be advantageously two main portions, trapezoidal in shape, formed symmetrically one to each other with regard to the central axis of the valvular structure, and two less rigid portions separating said two main portions to lead to a tight closeness in shape of a closed slot at the time of  
25 closure of the upper extremities of the main portions of the valvular structure. The thickened zones can be extended up to form the stiffened zones.

More particularly, each of said main slightly rigid portions occupy approximately one third of the circumference of the valvular structure when  
30 this latter is in its open position. The slightly rigid portions maintain the

valvular structure closed during diastole by firmly applying themselves on each other. The closure of the valvular structure at the time of diastole thus does not have any tendency to collapse too much towards the aortic annulus.

5 Preferably, the guiding means are a number of pleats formed within the tissue by folding, or formed by recesses or grooves made in the tissue. The shape of the pleats is adapted to achieve a global shape of the desired type for said position.

Alternatively, the guiding means are made of strengthening struts,  
10 preferably at least three, incorporated in the tissue in combination or not with said pleats.

The guiding means and, in particular, the strengthening struts, help to prevent the valvular tissue from collapsing back too much and to reverse inside the left ventricle through the base of the frame, preventing the risk of  
15 blood regurgitation.

In a preferred prosthetic valve of the invention, said valvular tissue is made of synthetic biocompatible material such as Teflon® or Dacron®, polyethylene, polyamide, or made of biological material such as pericardium, porcine leaflets and the like. These materials are commonly  
20 used in cardiac surgery and are quite resistant, particularly to folding movements due to the increasing systolo-diastolic movements of the valvular tissue and particularly at the junction with the frame of the implantable valve.

The valvular structure is fastened along a substantial portion of an  
25 expandable frame, by sewing, by molding or by gluing to exhibit a tightness sufficiently hermetical to prevent any regurgitation of said body fluid between the frame and the valvular structure.

Preferably, an internal cover is coupled or is integral to the valvular structure and placed between said valvular structure and the internal wall of  
30 the frame to prevent any passage of the body fluid through said frame.

Therefore, there is no regurgitation of blood as it would be the case if there were any space between the valvular structure fastened on the frame and the zone of application of the frame on the aortic annulus. The internal cover makes a sort of "sleeve" at least below the fastening of the valvular structure covering the internal surface of the frame and thus prevents any regurgitation of blood through the frame.

In the present invention, the frame is a substantially cylindrical structure capable of maintaining said body channel open in its expanded state and supporting said collapsible valvular structure.

In a preferred embodiment of the invention, the frame is made of a material which is distinguishable from biological tissue to be easily visible by non invasive imaging techniques.

Preferably, said frame is a stainless metal structure or a foldable plastic material, made of intercrossing, preferably with rounded and smooth linear bars. This frame is strong enough to resist the recoil phenomenon of the fibrous tissue of the diseased valve. The size of the bars and their number are determined to give both the maximal rigidity when said frame is expanded and the smallest volume when the frame is compressed.

More preferably, the frame has projecting curved extremities and presents a concave shape. This is aimed at reinforcing the embedding and the locking of the implantable valve in the distorted aortic orifice.

In a preferred embodiment of the present invention, the IV is made in two parts, a first reinforced frame coupled with a second frame which is made of thinner bars than said first frame and which is embedded inside the second frame. This second frame to which the valvular structure is fastened as described above, is preferably less bulky than the first frame to occupy as little space as possible and to be easily expanded using low pressure balloon inflation.

The present invention also relates to a double balloon catheter to separately position the first frame in the dilated stenosed aortic valve and

place the second frame that comprises the valvular structure. This catheter comprises two balloons fixed on a catheter shaft and separated by few centimeters.

5 The first balloon is of the type sufficiently strong to avoid bursting even at a very high pressure inflation and is aimed at carrying, in its deflated state, a strong frame aimed at scaffolding the previously dilated stenosed aortic valve. The second balloon is aimed at carrying the second frame with the valvular structure.

10 An advantage of this double balloon catheter is that each balloon has an external diameter which is smaller than known balloons since each element to be expanded is smaller.

Moreover, such a double balloon catheter allows to enlarge the choice for making an efficient valvular structure enabling to overcome the following two contradictory conditions:

15 1) having a soft and mobile valvular structure capable of opening and closing freely in the blood stream, without risk of being damaged by balloon inflation; and

20 2) needing a very strong structure able to resist the recoil force of the stenosed valve and capable of resisting, without any damage, a strong pressure inflation of the expanding balloon.

Furthermore, the shaft of said double balloon catheter comprises two lumens for successive and separate inflation of each balloon. Of note, an additional lumen capable of allowing a rapid inflation takes additional room in the shaft.

25 The invention also relates to a method of using a two-balloon catheter with a first frame and second frame to which a valve prosthesis of the type previously described is fastened.

DESCRIPTION OF THE DRAWINGS



The invention will now be explained and other advantages and features will appear with reference to the accompanying schematical drawings wherein :

5 - Figures 1a, 1b and 1c illustrate, in section views, respectively, the normal aortic valve in systole, in diastole and a stenosed aortic valve;

- Figures 2a and 2b illustrate two examples of a metallic frame which are combined to a valvular structure according to the present invention;

10 - Figures 3a and 3b illustrate a frame according to the invention in its expanded position with an opening out of the extremities, respectively, with a cylindrical and a concave shape;

- Figures 4a and b illustrate an IV of the invention respectively in its compressed position and in its expanded position in an open position as in systole;

15 - Figures 5a and 5b illustrate respectively an IV of the invention in its closed position and a sectional view according to the central axis of such a valvular structure which is closed as in diastole;

20 - Figures 6a to 6d illustrate a sectional view according to the central axis of an IV according to the present invention and showing the internal cover and the external cover of the valvular structure overlapping partially or non overlapping the frame bars;

- Figure 7 illustrates the frontal zig-zag fastening line of the valvular tissue on the frame;

25 - Figures 8a and 8b illustrate, respectively, a perspective view of a valvular structure and an internal cover made all of one piece and a perspective view of the corresponding frame into which they will be inserted and fastened;

30 - Figures 9a and 9b illustrate inclined strengthening struts, an example of a valvular structure according to the invention, respectively in the open position and in the closed position;

- Figures 10a and 10b illustrate an example of a valvular structure comprising pleats, respectively in the open and in the closed position;
- Figures 11a and 11b illustrate a valvular structure comprising two trapezoidal slightly rigid portions, respectively in the open and in the closed position;
- Figures 11c to 11e illustrate a valvular structure comprising a rectangular stiffened zone, respectively in the open, intermediate and closed position;
- Figures 12a and 12b illustrate, respectively, a perspective and cross sectional views of an implantable valve in its compressed presentation squeezed on a balloon catheter;
- Figures 13a to 13l illustrate views of the successive procedure steps for the IV implantation in a stenosed aortic orifice;
- Figure 14 illustrate an implantable valve made in two parts in its compressed presentation squeezed on a two-balloon catheter with a reinforced frame on a first balloon and with the implantable valve on the second balloon; and
- Figures 15a to 15f illustrate the successive steps of the implantation of the implantation valve in two parts with a two-balloon catheter;

#### DETAILED DESCRIPTION OF THE PREFERRED EMBODIMENTS

In the diastole and systole illustrations of section views of Figures 1a and 1b, the arrows A indicates the general direction of the blood flow. The semi-lunar leaflets 1 and 2 of a native aortic valve (with only two out of three shown here) are thin, supple and move easily from the completely open position (systole) to the closed position (diastole). The leaflets originate from an aortic annulus 2a.

The leaflets 1' and 2' of a stenosed valve as illustrated in Figure 1c, are thickened, distorted, calcified and more or less fused, leaving only a small hole or a narrow slit 3, which makes the ejection of blood from the left

ventricle cavity 4 into the aorta 5 difficult and limited. Figures 1a to 1c show also the coronary artery ostium 6a and 6b and Figure 1a shows, in particular, the mitral valve 7 of the left ventricle cavity 4.

5 An implantable valve according to the invention essentially comprises a supple valvular structure supported by a strong frame. The positioning of the implantable valve is an important point since the expanded frame has to be positioned exactly at the level of the native valvular leaflets 1, 2 of the native valve, the structures of which are pushed aside by the inflated balloon.

10 Ideally, the implantable valve is positioned with the fastening line of the valvular structure on the frame exactly on the remains of the crushed stenosed valve to prevent any regurgitation of blood. In practice, it is difficult to position the implantable valve within less than 2 or 3 mm. However, any risk of regurgitation of blood is eliminated with the presence  
15 of an internal cover, as will be described below.

The upper limit of the frame should be placed below the opening of the coronary arteries, i.e., the coronary ostia 6, or at their level so that the frame does not impede free blood flow in the coronary arteries. This point is a delicate part of positioning an IV since the distance between the superior  
20 limit of the leaflets of the natural valve and the coronary ostia 6 is only about 5 to 6 mm. However, the ostia are located in the Valsalva sinus 8 which constitutes a hollow that are located a little out of the way. This helps to prevent from impeding the coronary blood flow by the IV.

At the time of implantation, the operator evaluates the exact  
25 positioning of the coronary ostia by looking at the image produced by a sus-valvular angiogram with contrast injection performed before the implantation procedure. This image will be fixed in the same projection on a satellite TV screen and will permit the evaluation of the level of the origin of the right and left coronary arteries. Possibly, in case the ostia are not  
30 clearly seen by sus-valvular angiography, a thin guide wire, as those used

in coronary angioplasty, is positioned in each of the coronary arteries to serve as a marker of the coronary ostia.

The lower part of the frame of the IV preferably extends by 2 or 3 mm inside the left ventricle 4, below the aortic annulus 2a. However, this  
5 part of the frame should not reach the insertion of the septal leaflet of the mitral valve 7, so that it does not interfere with its movements, particularly during diastole.

Figures 2a and 2b show respectively an example of a cylindrical  
10 frame 10 comprising intercrossing linear bars 11, with two intersections I by bar 11, the bars 11 being soldered or provided from a folded wire to constitute the frame, with for instance a 20 mm, 15 mm or 12 mm height, and an example with only one intersection of bars 11. Preferably, such a frame is expandable from a size of about 4 to 5 millimeters to a size of about 20 to 25 mm in diameter, or even to about 30-35 mm (or more) in  
15 particular cases, for instance for the mitral valve. Moreover, said frame, in its fully expanded state, has a height of approximately between 10 and 15 mm and in its fully compressed frame, a height of approximately 20 mm. The number and the size of the bars are adapted to be sufficiently strong and rigid when the frame is fully open in the aortic orifice to resist the  
20 strong recoil force exerted by the distorted stenosed aortic orifice after deflation of the balloon used in the catheterization technique which has been previously maximally inflated to enlarge the stenosed valve orifice;

The frame may have several configurations according to the number of bars 11 and intersections. This number, as well as the size and  
25 the strength of the bars 11, are calculated taking into account all the requirements described, i.e., a small size in its compressed form, its capacity to be enlarged up to at least 20 mm in diameter and being strong when positioned in the aortic orifice to be able to be forcefully embedded in the remains of the diseased aortic valve and to resist the recoil force of the

aortic annulus. The diameter of the bars is chosen, for instance, in the range of 0.1-0.6 mm.

5 A frame particularly advantageous presents, when deployed in its expanded state, an opening out 12 at both extremities as shown in Figures 3a and 3b, the frame having a linear profile (Figure 3a) or a concave shape profile (Figure 3b). This is aimed at reinforcing the embedding of the IV in the aortic orifice. However, the free extremities of the openings 12 are rounded and very smooth to avoid any traumatism of the aorta or of the myocardium.

10 The structure of a preferred frame used in the present invention both maintains the aortic orifice fully open once dilated and produces a support for the valvular structure. The frame is also foldable. When folded by compression, the diameter of said frame is about 4 to 5 millimeters, in view of its transcutaneous introduction in the femoral artery through an  
15 arterial sheath of 14 to 16 F (F means French, a unit usually used in cardiology field) i.e., about 4.5 to 5.1 mm. Also, as described below, when positioned in the aortic orifice, the frame is able to expand under the force of an inflated balloon up to a size of 20 to 23 mm in diameter.

The frame is preferably a metallic frame, preferably made of steel.  
20 It constitutes a frame with a grate type design able to support the valvular structure and to behave as a strong scaffold for the open stenosed aortic orifice.

When the frame is fully expanded, its intercrossing bars push  
25 against the remains of the native stenosed valve that has been crushed aside against the aortic annulus by the inflated balloon. This produces a penetration and embeds the bars within the remains of the stenosed valve, in particular owing to a concave profile of the frame provided with an opening out, as illustrated in Figure 3b. This embedding of the frame on the aortic annulus, or more precisely on the remains of the crushed distorted

aortic valve, will be determinant for the strong fixation of the IV in the right position, without any risk of displacement.

Moreover, the fact that the valve leaflets in degenerative aortic stenosis are grossly distorted and calcified, sometimes leaving only a small hole or a small slit in the middle of the orifice, has to be considered an advantage for the implantation of the valve and for its stable positioning without risk of later mobilization. The fibrous and calcified structure of the distorted valve provides a strong base for the frame of the IV and the powerful recoil phenomenon that results from elasticity of the tissues contribute to the fixation of the metallic frame.

The height of the fully expanded frame of the illustrated frames is preferably between 10 and 15 mm. Indeed, since the passage from the compressed state to the expanded state results in a shortening of the metallic structure, the structure in its compressed form is a little longer, i.e., preferably about 20 mm length. This does not constitute a drawback for its transcutaneous introduction and its positioning in the aortic orifice.

As mentioned above, the frame is strong enough to be able to oppose the powerful recoil force of the distended valve and of the aortic annulus 2a. Preferably it does not possess any flexible properties. When the frame has reached its maximal expanded shape under the push of a forcefully inflated balloon, it remains substantially without any decrease in size and without any change of shape. The size of the bars that are the basic elements of the frame is calculated in such a way to provide a substantial rigidity when the frame is fully expanded. The size of the bars and their number are calculated to give both maximal rigidity when expanded and the smallest volume when the metallic frame is its compressed position.

At the time of making the IV, the frame is expanded by dilatation to its broadest dimension, i.e., between 20 mm and 25 mm in diameter, so as to be able to fasten the valvular structure on the inside side of its surface.

This fastening is performed using the techniques in current use for the making of products such as other prosthetic heart valves or multipolars catheters etc. Afterwards, it is compressed in its minimal size, i.e., 4 or 5 mm, in diameter in view of its introduction in the femoral artery. At time of  
5 the IV positioning, the frame is expanded again by balloon inflation to its maximal size in the aortic orifice.

If the frame is built in an expanded position, it will be compressed, after fastening the valvular structure, by exerting a circular force on its periphery and/or on its total height until obtaining the smallest compressed  
10 position. If the frame is built in its compressed position, it will be first dilated, for instance, by inflation of a balloon and then compressed again as described above.

To help localizing the IV, the frame being the only visible component of the valve, the shaft of the balloon catheter on which will be  
15 mounted the IV before introduction in the body (see below) possesses preferentially metallic reference marks easily seen on fluoroscopy. One mark will be at level of the upper border of the frame and the other at the level of the lower border. The IV, when mounted on the catheter shaft and crimped on it, is exactly positioned taking into account these reference  
20 marks on the shaft.

Accordingly, the frame is visible during fluoroscopy when introduced in the patient's body. When the frame is positioned at the level of the aortic annulus, the upper border of the frame is placed below the coronary ostia. Furthermore, the implanting process during which the  
25 balloon inflation completely obstructs the aortic orifice, as seen below, is performed within a very short time, i.e., around 10 to 15 seconds. This also explains why the frame is clearly and easily seen, without spending time to localize it. More particularly, its upper and lower borders are clearly delineated.

Figures 4a and 4b show an example of a preferred IV 13 of the present invention, respectively in its compressed position, in view of its introduction and positioning in the aortic orifice, and in its expanded and opened (systole) position. Figures 5a and 5b show the expanded position of this example closed in diastole, respectively in perspective and in a  
5 crossed section view along the central axis X'X of the valve prosthesis.

The valvular structure 14 is compressed inside the frame 10 when this is in its compressed position (Figure 4a), i.e., it fits into a 4 to 5 mm diameter space. On the other hand, the valvular structure can expand  
10 (Figure 4b) and follow the frame expansion produced by the inflated balloon. It will have to be able to reach the size of the inside of the fully deployed frame.

The illustrated IV 13 is made of a combination of two main parts:

1) the expandible but substantially rigid structure made of the frame  
15 10, a metallic frame in the example; and

2) a soft and mobile tissue constituting the valvular structure 14 exhibiting a continuous surface truncated between a base 15 and an upper extremity 16; the tissue is fastened to the bars 11 of the frame at its base 16 and is able to open in systole and to close in diastole at its extremity 16,  
20 as the blood flows in a pulsatile way from the left ventricle towards the aorta.

The tissue has rectilinear struts 17 incorporated in it in plane including the central axis X'X, in order to strengthen it, in particular, in its closed state with a minimal occupation of the space, and to induce a  
25 patterned movement between its open and closed state. Other examples of strengthening struts are described below. They are formed from thicker zones of the tissue or from strips of stiffening material incorporated in the tissue; they can also be glued or soldered on the valvular tissue.

These strengthening struts help to prevent the valvular tissue from  
30 collapsing back too much and to evert inside the left ventricle through the



base of the frame. These reinforcements of the valvular tissue help maintain the folded tissue above the level of the orifice during diastole, prevent too much folding back and risk of inversion of the valvular structure inside the left ventricle. By also preventing too much folding, a decrease of the risk of thrombi formation can also be expected by reducing the number of folds.

The truncated shape forming a continuous surface enables to obtain a strong structure and is more efficient for the systolo-diastolic movements of the valvular tissue during heart beats. The truncoïdal shape facilitates the closure of the valve structure at the beginning of diastole in facilitating the start of the reverse movement of the valvular tissue towards its base at the time of diastole, i.e., at the time of flow reversal at the very beginning of diastole. During diastole, the valvular structure 14 thus falls down, folding on itself, thereby collapsing on its base, and therefore closing the aortic orifice. In fact, the valvular structure has preferably, as illustrated, an hyperboloïd shape, with a curvature on its surface concave towards the aortic wall that will contribute to initiating its closure.

Moreover, the basis of the truncated hyperboloïd is fixed on the lower part of a frame and the smallest extremity of the truncated hyperboloïd is free in the blood stream, during the respected closing and opening phasis.

An important advantage of this hyperboloïdal shape is that the upper extremity 16 of the valvular structure 14 can remain at a distance from the coronary ostia during systole as well as during diastole, because of its smaller diameter, thus offering an additional security to make certain that the passage of blood from aorta to the coronary ostia is not impeded.

The base 15 of the truncated tissue is attached on the frame 10 along a line of coupling 18 disposed between the inferior fourth and the third fourth of the frame in the example. The upper extremity 16, with the smaller diameter, overpasses the upper part of the frame by a few

millimeters; 6 to 8 mm, for instance. This gives the valvular structure a total height of about 12 to 15 mm.

The upper extremity 16 of the truncated tissue, i.e., the smaller diameter of the hyperboloïdal structure 14, is about 17 to 18 mm in diameter (producing a 2.3 to 2.5 cm<sup>2</sup> area opening) for a 20 mm diameter base of the truncated structure, or 19 to 20 mm in diameter (producing a 2.8 or a 3 cm<sup>2</sup> area opening) for a 23 mm diameter base. An opening area around 2 cm<sup>2</sup> or slightly above, gives satisfactory results, particularly in elderly patients who would not reasonably need to exert high cardiac output.

For instance, in the present example, the line of fastening of the base of the truncated tissue on the frame will have to expand from a 12.5 mm perimeter (for a 4 mm external diameter of the compressed IV) to a 63 mm perimeter ( for a 20 mm external diameter of the expanded IV ), or to a 72 mm perimeter (for a 23 mm external diameter, in case a 23 mm balloon is used).

Another advantage of this truncated continuous shape is that it is stronger and has less risk of being destroyed or distorted by the forceful balloon inflation at the time of IV deployment. Also, if the truncated hyperboloïdal shape is marked, for instance, with a 16 or 17 mm diameter of the upper extremity as compared to a 20 mm diameter of the base (or 18 to 20 mm for 23 mm), the smaller upper part is compliant during balloon inflation in order to enable the balloon to expand cylindrically to its maximal 20 mm diameter (or 23 mm). This is made possible by using a material with some elastic or compliant properties.

The valvular structure of the invention, as shown in the illustrated example, includes advantageously a third part, i.e., the internal cover 19 to be fixed on the internal wall of the frame 10. This internal cover prevents any passage of blood through the spaces between the bars 11 of the frame in case the implantable valve would be positioned with the fastening line of

the valvular structure on the frame not exactly on the remains of the dilated aortic valve, i.e., either above or below. It also strengthens the fastening of the valvular structure 14 to the frame 10.

In the different sectional views of the different examples of IV according to the invention, as illustrated at Figures 6a to 6c, the internal cover 19 covers the totality of the internal side of the frame 10 (Figure 6a), only the lower part of the frame 10 (figure 6b), or it can additionally cover partially 3 to 5 mm as shown in the passage of blood from aorta to the coronary ostia Figure 6c, the upper part defined above the coupling line 18 of the valvular structure.

For instance, such an extension of the internal cover 19 above the fastening line 18 of the valvular structure will give another security to avoid any risk of regurgitation through the spaces between the bars 11 in case the IV would be positioned too low with respect to the border of the native aortic valve.

The internal cover can also be molded to the valvular structure or casted to it which therefore constitutes an integral structure. The valvular structure and the internal cover are therefore strongly locked together with minimum risk of detachment of the valvular structure which is unceasingly in motion during systole and diastole. In that case, only the internal cover has to be fastened on the internal surface of the frame which renders the making of the IV easier and makes the complete device stronger and more resistant. In particular, the junction of the mobile part of the valvular structure and the fixed part being molded as one piece is stronger and capable to face the increasing movements during the systolo-diastolic displacements without any risk of detachment.

The presence of the internal cover makes an additional layer of plastic material that occupies the inside of the frame and increases the final size of the IV. Therefore, in the case in which the internal cover is limited to the inferior part of the frame (that is, below the fastening line of the valvular

structure), it does not occupy any additional space inside the frame. Here also, it is more convenient and safer to make the valvular structure and this limited internal cover in one piece.

In other aspects, to prevent any regurgitation of blood from the aorta towards the left ventricle during diastole, the base of the valvular structure is preferably positioned exactly at the level of the aortic annulus against the remains of distorted stenosed valve pushed apart by the inflated balloon. Therefore, there is no possibility of blood passage through the spaces between the metallic frame bars 11 below the attachment of the valvular structure.

However, to avoid any risk of leaks, the part of the frame below the fastening of the valvular structure (about 3 to 5 mm) is preferably covered by an internal cover which is preferably made with the same tissue as the valvular structure. Thus, there would be no regurgitation of blood which is a possibility when there is any space between the valvular structure fastened on the metallic frame and the line of application of the frame on the aortic annulus. The internal cover makes a sort of "sleeve" below the fastening of the valvular structure on the internal surface of the frame, covering the spaces between the frame bars of the frame at this level, thus preventing any regurgitation of blood through these spaces.

The internal cover can also have another function, i.e., it can be used to fasten the valvular structure inside the frame, as described below.

At Figure 6d, the internal cover 19 is extended at its lower end 19' to an external cover 19" which is rolled up to be applied on the external wall of the stent 10. The internal and external cover are molded, glued or soldered to the bars of the stent 10.

The coupling process of the valvular structure on the frame is of importance since it has to be very strong without any risk of detachment of the valvular structure from the frame during millions of heart beats with pulsatile blood flow alternatively opening and closing the valvular structure.

The valvular structure of the invention folds to a very small size inside the frame in the compressed position of the valve and is expandable up to 20 to 23 mm diameter. Also, the valvular structure can resist the strong force exerted by the maximally inflated balloon that will powerfully squeeze it against the bars of the frame or against the internal cover, this one being squeezed directly against the bars of the frame. The junction zone is also particularly subjected to very strong pressure exerted by the inflated balloon. Furthermore, this junction zone must not tear or break off during expansion of the balloon. At this time, each part of the junction zone is squeezed against the bars but nonetheless follows the expansion of the frame.

As shown in Figure 7, the junction zone is, for example, a fastening line 20 which follows the design of a "zig-zag" line drawn by the intercrossing bars 11 of the frame on the internal cover 19.

The fastening of the valvular structure to the frame can be made by sewing the internal and/or the external cover to the bars. To prevent any leakage of blood, stitches are preferably numerous and very close to each other, either as separated stitches or as a continuous suture line. Also, the stitches are made directly around the bars 11. Furthermore, since the valvular structure is expanded together with the metallic frame, the stitches, if made as a continuous suture line, are also able to expand at the same time.

The fastening process can also be made by molding the base of the valvular structure on the frame. At this level, the bars 11 are imbedded in the coupling line of the valvular structure 14. This mold way also concerns the internal cover 19, when it goes below the coupling line 14 on the frame over few millimeters, for example, 2 to 4 mm. As mentioned above, this is intended in order to prevent any regurgitation of blood just below the lower part of the valvular structure 14 in case the frame would not be exactly positioned on the aortic annulus but at few millimeters away.

The fastening process can further be made by gluing or soldering the valvular structure on the bars with sufficiently powerful biocompatible glues. The same remark can be made concerning the internal cover of the frame below the coupling line of the valvular structure.

5 Also, this allows the coupling line to follow the frame changes from the compressed position to its expanded one.

The valvular structure can also be fastened on the internal cover previously fixed at the total length of the internal surface of the metallic frame. The internal cover constitutes therefore a surface on which any type  
10 of valvular structure be more easily sewed, molded or glued. Because it is a structure with a large surface and is not involved in the movements of the valvular tissue during systole and diastole, the internal cover is more easily fastened to the internal surface of the frame.

In the particular embodiment shown in Figure 8, the internal cover  
15 19 is fastened, after introduction (indicated by the arrow B), at the upper and lower extremities of the frame 10 on the upper and lower zig-zag lines of the intercrossing bars 11. In fact, the fastening of the internal cover 19 on the zig-zag lines made by the intercrossing bars 11 of the frame allows an easier passage of blood from the aorta above the IV towards the  
20 coronary ostia. Indeed, the blood can find more space to flow into the coronary ostia by passing through the lowest point of each triangular space made by two intercrossing bars 11, as indicated by the arrows A1 (see also Figure 1b).

The fastening of the internal cover 19 on the extremities can be  
25 reinforced by various points of attachment on various parts of the internal surface of the frame 10. The internal cover 27 can be fastened by sewing, molding or gluing the bars 11 onto the frame.

Fastening the valvular tissue (and the cover tissue below) on the  
inside of the frame, requires work on the frame in its expanded position to  
30 have access to the inside of this cylindric frame. In a preferred embodiment

the frame is expanded a first time for fastening the valvular tissue on its bars, then compressed back to a smaller size to be able to be introduced via arterial introducer and finally expanded again by the balloon inflation.

Since it is aimed at being positioned in the heart after having been  
5 introduced by a catheterization technique by a transcutaneous route in a peripheral artery, mainly the femoral artery, the IV should preferably have the smallest possible external diameter. Ideally, it should be able to be introduced in the femoral artery through a 14 F (4,5 mm) size arterial introducer which is the size of the arterial introducer commonly used to  
10 perform an aortic dilatation. However, a 16 F (5,1 mm) or even a 18 F (5,7 mm) introducer would also be acceptable.

Above this size, the introduction of the IV in the femoral artery should probably be done by a surgical technique. This is still quite acceptable since the surgical procedure would be a very light procedure  
15 which could be done by a surgeon with a simple local anaesthesia. It has to be recalled that this technique is used to position big metallic frames, about 24 F in size (7.64 mm in diameter), in the abdominal aorta for the treatment of aneurysms of the abdominal aorta. In that situation, this necessitates surgical repair of the artery after withdrawal of the sheath (M. D. Dake, New  
20 Engl. J Med. 1994;331:1729-34).

Ideally, an IV should be able to last several tenths of life years without defect, like the mechanical prosthetic valves which are currently implanted by the surgeons. Nevertheless, an implantable valve that would last at least ten years without risk of deterioration would be effective for the  
25 treatment of elderly patients.

A valvular structure according to the invention is made of a supple and reinforced tissue which has a thickness to be thin enough to occupy as less as possible space in the compressed form of the valve, is pliable, and also strong enough to stand the unceasing movements under the blood  
30 pressure changes during heart beats. The valvular structure is capable of

moving from its closed position to its open position under the action of the force exerted by the movements of the blood during systole and diastole, without having any significant resistance to blood displacements.

The material used for the tissue, which exhibits the above mentioned requirements, may be Teflon<sup>®</sup> or Dacron<sup>®</sup>, which are quite resistant to folding movements, at least when they are used to repair cardiac defects such as inter-atrial or interventricular defects or when they are used to repair a valve such as the mitral valve which is subjected to high pressure changes and movements during heart beats. Also, a main point is the increasing systolo-diastolic movements of the valvular tissue, particularly at its junction with the rigid part of the IV, and it is therefore necessary to find the most possible resistant material tissue.

As mentioned previously, the valvular structure can also possibly be made with biological tissue such as the pericardium, or with porcine leaflets, which are commonly used in bioprosthetic surgically implanted valves.

Moreover, the valvular prosthesis of the present invention does not induce any significant thrombosis phenomenon during its stay in the blood flow and is biologically neutral.

To prevent the risk of thrombus formation and of emboli caused by clots, a substance with anti-thrombic properties could be used, such as heparine, ticlopidine, phosphorylcholine, etc. either as a coating material or it can be incorporated into the material used for the implantable valve, in particular, for the valvular structure and/or for the internal cover.

The valvular structure of the invention can have several types of designs and shapes. Besides the example illustrated in Figures 4 and 5, examples of strengthened valvular structures according to the invention are shown in Figures 9 to 11, respectively in the closed (figures 9a, 10a, 11a) and in the open state (figures 9b, 10b, 11b) to form a prosthetic valve



according to the present invention. In those figures, the frame line is simplified to clarify the drawings.

To help initiate and finalize the closure of the valvular structure, four strengthening struts 14 are slightly inclined from the base to the upper part as compared to the central axis X'X of the structure, as shown in  
5 Figures 9a and 9b. Accordingly, a patterned movement of the valvular structure, during the closing and the opening phases, is initiated. This patterned movement is, in the present case, an helicoïdal-type one, as suggested in Figures 9b and 10b by the circular arrow.

10 Figures 10a and 10b illustrate another embodiment to help the closing of the valvular structure and which also involves an helicoïdal movement. Represented by lines 22, inclined pleats are formed in the tissue to impart such a movement. As illustrated, these lines have an inclination from the base to the upper part of the tissue 14. Pleats are  
15 formed by folding the tissue or by alternating thinner and thicker portions. The width and the number of those pleats are variable, and depend particularly on the type of material used. According to another example, these pleats 34 are combined with the above described inclined strengthening struts.

20 These reinforcing pleats and/or struts, rectilinear or inclined, have the advantage to impart a reproducible movement and, accordingly, to avoid the valvular structure from closing to a nonstructured collapse on the frame base.

Another shape of the valvular structure comprises two portions:  
25 one portion being flexible but with some rigidity, having a rectangular shape, occupying about one third of the circumference of the valvular structure, and the other portion being more supple, flexible and foldable occupying the rest of the circumference at its base as well as at its upper, free border. According to Figure 11c, this valve is opened, during the  
30 ejection of blood, i.e., during systol. In Figure 11d, a front view of the valve

is closed, during an intermediate diastole, and in Figure 11e the same closed valve during diastole is shown from a side view. The semi-rigid part 24' moves little during systole and during diastole. The foldable part 23' moves away from the rigid part during systole to let the blood flow through the orifice thus made. This orifice, due to the diameter of the upper part which is the same as that of the open stent, is large, generally as large as that of the open stent. At the time of diastole, due to the reverse of pressure, the foldable part moves back towards the semi-rigid part and presses on it, and thus closes the orifice and prevents any regurgitation of blood.

The advantage of such a valve design is to allow a large opening of the upper part of the valvular structure, not only to permit more blood flow at time of systole after the valve has been implanted, but also at the very time of implantation, when the balloon is maximally inflated to expand the valve to imbed it in the valvular annulus. The diameter of the upper part of the valvular structure could be the same size as the balloon, so that there would be no distension of the valvular part of the valve at the time of implantation, and therefore no risk of deterioration of the valvular structure by the inflated balloon.

The foldable part of the valve could be reinforced by strengthening struts to prevent an eversion of the valve towards the left ventricle during diastole.

Another shape of the valvular structure, as illustrated in Figures 11a and 11b comprise four portions, alternatively a main portion 23 and a more narrow portion 24. The main and the narrow portions are facing each other. Each portion has an isosceles trapezoidal shape. The main portions 23 are flexible but with some slight rigidity and the more narrow portions 24 are compliant, more supple and foldable. In this type of design, the two slightly rigid portions 23 maintain the valvular structure closed during diastole by firmly applying on each other in their upper extremities, thus

forming a slot-like closure 25. This particular embodiment needs less foldable tissue than in the previous embodiments and the closure of the valvular structure at the time of early diastole does not have any tendency to collapse towards the aortic annulus.

5           Another design for the valvular structure is a combination of a cylindrical shape followed by a truncated shape.

          This type of valvular structure is longer than the hyperbolic type, for instance, 25 or 30 mm long, therefore exceeding out of the upper part of the metallic frame, by 10 to 20 mm. The cylindrical part corresponds to the  
10   metallic frame and remains inside it. The truncated conic shape is the upper part of the valvular structure, totally exceeding out of the upper extremity of the metallic frame. An advantage of such a design is that the balloon can be inflated only in the cylindrical part of the valvular structure, therefore without risk of stretching the truncated conical part of the upper  
15   diameter which is smaller than that of the inflated balloon.

          When the upper extremity of the cylindrical part has the same size as the lower extremity, there is no difference during balloon inflation in the degree of force exerted by the balloon on the lower and on the upper extremity of the valvular structure. Preferably, rectilinear reinforcing struts  
20   are used in this embodiment, to strengthen the valve structure and aid in its shutting without collapsing and inverting inside the left ventricle through the aortic annulus under the force of the diastolic pressure.

          Two different processes for implanting a valve according to the present invention are shown respectively in Figures 13a to 13i with a  
25   unique balloon catheter, as illustrated in Figures 12a and 12b and in Figures 15a to 15f, with a two-balloon catheter, as illustrated in Figure 14.

          The IV positioning in the aortic orifice and its expansion can be performed with the help of a unique substantially cylindrical balloon catheter 26 in the so-called unique-balloon catheterization technique.

Preparing for its introduction by transcutaneous route in the femoral artery, the IV 13 is, as illustrated in the perspective view of Figure 10a in a compressed form crimped on the balloon catheter 26. A central sectional view of the mounted IV 13 on the complete balloon catheter 26 is shown in  
5 Figure 12b.

The shaft 27f of the balloon dilatation catheter 26 is as small as possible, i.e., a 7F (2.2 mm) or a 6 F (1.9 mm) size. The balloon 26 is mounted on the shaft 27 between two rings R. Moreover, the shaft 27 comprises a lumen 28 (Figure 12b) as large as possible for inflation of the  
10 balloon 26 with diluted contrast to allow simple and fast inflation and deflation. It has also another lumen 29 able to accept a stiff guide wire 30, for example 0.036 to 0.038 inches (0.97 mm), to help position the implantable valve with precision.

The balloon 26 has, for example, a 3 to 4 cm length in its cylindrical  
15 part and the smallest possible size when completely deflated so that it will be able to be placed inside the folded valve having an outside diameter which ranges between about 4 and 5 mm. Therefore, the folded balloon preferably has at the most a section diameter of about 2.5 to 3 mm.

The balloon is therefore made of a very thin plastic material. It is  
20 inflated with saline containing a small amount of contrast dye in such a way to remain very fluid and visible when using X-ray.

However, the balloon 26 has to be sufficiently strong to resist the high pressure that it has to withstand to be capable of expanding the folded valvular structure 14 and the compressed frame in the stenosed aortic  
25 orifice considering that, although pre-dilated, the aortic orifice still exerts a quite strong resistance to expansion because of the recoil phenomenon.

This procedure is shown in Figures 13a to 13e.

In contrast to the technique used when performing the usual aortic dilatation (without valve implantation), i.e., inflating the balloon maximally  
30 markedly above the nominal pressure, if possible, up to the bursting point

(which occurs always with a longitudinal tear, without deleterious consequence, and with the advantage of both exerting a maximal dilating force and restoring blood ejection instantaneously), the balloon inflated for expansion of an implantable valve should not burst in any case. Indeed, 5 bursting of the balloon would involve a risk of incomplete valve expansion and wrong positioning. Therefore, the balloon should be very resistant to a very high pressure inflation. Furthermore, the balloon is inflated only up to the nominal pressure indicated by the maker and the pressure is controlled during inflation by using a manometer. Such relatively low pressure should 10 be sufficient since prior to positioning the IV, an efficacious dilatation of the stenosed aortic valve according to the usual technique with a maximally inflated balloon for example 20 mm or 25 mm in size in such a way to soften the distorted valvular tissue and facilitate the enlargement of the opening of the valve at time of IV implantation is performed.

15 The implantation of the aortic valve 20 can be made in two steps, as described as follows.

The first step, as shown in Figures 13a to 13f, consists in introducing the shaft 27 and balloon catheter 26 along the guide wire previously positioned in the ventricle 4 (Figures 13a-13b). The dilatation of 20 the stenosed aortic valve 1', 2' using a regular balloon catheter, according to the commonly performed procedure, i.e., with the guide wire 30 introduced in the ventricle 4 (Figure 13a) and with maximal inflation of the balloon 26 (Figures 13c to 13d) up to the bursting point. Dilatation is performed at least with a balloon having about 20 mm diameter, but it can 25 be performed with a balloon having about 23 mm diameter so as to increase maximally the aortic orifice opening before implantation of the valve although the implantable valve is about 20 mm in diameter. This preliminary dilatation of the aortic orifice helps in limiting the force required to inflate the balloon used to expand the implantable valve and position it in 30 the aortic orifice, and also in limiting the recoil of the aortic valve that

occurs immediately after balloon deflation. The balloon is deflated (Figure 13a) and pulled back on the wire guide 30 left inside the ventricle.

Owing to the marked recoil of the stenosed valve and also of the strong aortic annulus, the 20 mm diameter valve is forcefully maintained against the valvular remains at the level of the aortic annulus. Preliminary dilatation has another advantage in that it permits an easier expansion of the IV, having a lower pressure balloon inflation which helps prevent damage of the valvular structure of the IV. This also facilitates the accurate positioning of the prosthetic valve.

The second step corresponds to the implantation of the valve 13 is shown in Figures 13g to 13l. The positioning of the IV needs to be precise at a near 2 or 3 mm, since the coronary ostia 6 has to remain absolutely free of any obstruction by the valve 13 (Figures 13k and 13l). As mentioned above, this is, for example, performed with the help of the image of the subvalvular angiogram in the same projection fixed on an adjacent TV screen. The expansion and the positioning of the valve prosthesis 13 is performed within a few seconds (15 to 20 among at most) since during the maximal balloon inflation (which has to be maintained only a very few seconds, 3, 4, 5) the aortic orifice is obstructed by the inflated balloon 31 and the cardiac output is zero (Figure 13h). As for the pre-dilatation act itself, the balloon 26 is immediately deflated within less than 5 or 6 seconds (Figure 13j) and, as soon as the deflation has clearly begun, the closing and opening states of the IV are active whereas the balloon is pulled back briskly in the aorta (Figures 13j to 13l). In case the IV is not maximally expanded by the first inflation, it is possible to replace the balloon inside the IV and to reinflate it so as to reinforce the expansion of the IV.

The IV 13 can also be used in aortic regurgitation. This concerns more often younger patients rather than those with aortic stenosis. The contraindication to surgical valve replacement is often not due to the old age of the patients, but stems mainly from particular cases where the

general status of the patient is too weak to allow surgery, or because of associated pathological conditions. Apart from the fact that there is no need for a preliminary dilatation, the procedure of the valve implantation remains approximately the same. The balloon inflation inside the IV is chosen  
5 accordingly, taking also into account the fact that it is necessary to overdilate the aortic annulus to obtain a recoil phenomenon of the annulus after balloon deflation to help maintain the IV in position without any risk of displacement.

However, the size of the expanded implantable valve is around 25  
10 to 30 mm in diameter, or even bigger, because the aortic annulus is usually enlarged. A preliminary measurement of the annulus will have to be performed on the sus-valvular angiography and by echocardiography to determine the optimal size to choose.

The IV can be used in the mitral position, mainly in case of mitral  
15 regurgitation, but also in case of mitral stenosis. Here again, the IV 20 is only described when used only in cases of contraindication to surgical valve repair or replacement. The procedure is based on the same general principles though the route for the valve positioning is different, using the transseptal route, like the commonly performed mitral dilatation procedure  
20 in mitral stenosis. The IV size is quite larger than for the aortic localization (about 30 to 35 mm in diameter when expanded or clearly above in case of a large mitral annulus, a frequent occurrence in mitral insufficiency), to be capable of occupying the mitral area. A preliminary measurement of the mitral annulus is performed to determine the optimal implantable valve size  
25 to choose. Since the introduction of the IV is performed through a venous route, almost always through the femoral vein which is quite large and distensible, the bigger the size of the IV in its compressed position is not a drawback even if the diameter size is about 6 or 7 mm. Moreover, the problem of protection of the coronary ostia as encountered in the aortic

position does not exist here which therefore makes the procedure easier to be performed.

Finally, the IV can be used to replace the tricuspid valve in patients with a tricuspid insufficiency. This procedure is simple to perform since the  
5 positioning of the IV is made by the venous route, using the shortest way to place in the right position at the level of the tricuspid orifice practically without any danger from clot migration during the procedure. A large implantable valve is used, with a diameter of about 40 mm or even larger because the tricuspid annulus is often markedly dilated in tricuspid  
10 insufficiency. Here also, as in the mitral position, the compressed IV and the catheter used can be without inconvenience, quite larger than that for the aortic position because of the venous route used.

Furthermore, it has to be noted that the IV can be used also as a first step in the treatment of patients who have contraindication to surgery,  
15 when they are examined for the first time, but who could improve later on after correction of the initial hemodynamic failure. The IV procedure can be used as a bridge towards surgery for patients in a weak general condition which are expected to improve within the following weeks or months after the IV procedure in such a way that they can be treated by open heart  
20 surgery later on. In the same vein, the IV procedure can be used as a bridge towards surgical valve replacement or repair in patients with a profoundly altered cardiac function that can improve secondarily owing to the hemodynamic improvement resulting from the correction of the initial valvular disease by the IV implantation.

25 Another technique for implantation of an aortic valve by transcutaneous catheterization uses a two-balloon catheter.

An example of this technique using the two parts IV with a two-balloon catheter 40 is shown in Figure 14.

Two-balloons 26 and 26' are fixed on a unique catheter shaft 27,  
30 said balloons being separated by a few millimeters. The two balloons are



preferably short, i.e., about 2 to 2.5 cm long in their cylindrical part. The first balloon 26 to be used, carries a first frame 10 aimed at scaffolding the stenosed aortic orifice after initial dilatation. This first balloon 26 is positioned on the aorta side, above the second balloon 26' which is positioned on the left ventricle side. The second balloon 26' carries the expandable valve 13 which is of the type described above made of a second frame 10' and a valvular structure 14 attached to said frame 10'. The difference is that the second frame does not need to be as strong as the first frame and is easier to expand with low balloon pressure inflation which does not risk damaging the valvular structure 14.

This enlarges the choice for making a valvular structure without having to face two contradictory conditions:

- 1) having a soft and mobile valvular structure 14 capable of opening and closing freely in the blood stream without risk of being damaged by a balloon inflation; and
- 2) needing a reinforced frame strong enough to be capable of resisting without any damage, a strong pressure inflation of the expanding balloon.

The shaft 27 of this successive two-balloon catheter 40 comprises two lumens for successive and separate inflation of each balloon. Indeed, an additional lumen capable of allowing a fast inflation occupies space in the shaft and therefore an enlargement of the shaft is necessary. However, this enlargement of the shaft stops at the level of the first balloon 26 since, further to said first balloon, only one lumen is necessary to inflate the second balloon 26', at the level of the IV which is the biggest part of the device.

Another advantage of this two part IV with a two-balloon catheter is that each set of implantable valve and balloon has a smaller external diameter since each element to be expanded, considered separately, is

smaller than in combination. This allows obtaining more easily a final device with an external diameter 14 F.

The first balloon is sufficiently strong to avoid bursting even at a very high pressure inflation. This first balloon is mounted in the frame in its  
5 deflated position, prior to its introduction by the strong frame which is aimed to scaffold the dilated stenosed aortic valve. The size and shape of said frame is comparable to what has been described previously but said frame is calculated (in particular the material, the number and diameter of its bars are chosen by the person skilled in the art) to make sure that it will resist  
10 the recoil of the dilated valve and that it will be securely embedded in the remains of the native aortic valve.

The second balloon does not need to be as strong as the first one and, therefore, can be thinner, occupying less space and being easier to expand with a lower pressure for balloon inflation. This second balloon 26'  
15 is mounted in the valve itself which, as in the preceding description, comprises a frame to support the valvular structure and said valvular structure.

Also, the second frame 10' does not need to be as strong as the first one. This frame can be slightly shorter, 10 mm instead of 12 mm, and  
20 its bars can be thinner. This frame can have an external surface which is a bit rough to allow better fixation on the first frame when expanded. The bars may also have some hooks to fasten to the first frame.

The valvular structure is attached on said second frame and expanded by relatively low pressure in the second balloon called hereafter  
25 the IV balloon. It does not need to be as strong as in the preceding case (IV in one part and unique balloon catheter technique) and, therefore, it occupies less space and has less risk to be damaged at the time of expansion.

This technique is shown in Figures 15a to 15f.

One of the problems relevant to the IV implantation procedure as described above, with the IV in one part, is the expansion at the same time by the same balloon inflation of both the frame and the valvular structure. Indeed, the frame is a solid element and the valvular structure is a relative  
5 weak one that could be damaged when squeezed by the inflated balloon.

Therefore, the valve implantation can be performed in two immediately successive steps. The first step (Figures 15a-15b) corresponds to the expansion and the positioning of the first frame with the first balloon 26 wherein inflation is performed at a high pressure. The  
10 second step (Figures 15d-15e) corresponds to the expansion and the positioning of the valvular structure 14 inside the frame 10' using the second balloon 26'. This second step follows the first one within a few seconds because, in the time interval between the two steps, there is a total aortic regurgitation towards the left ventricle which is an hemodynamic  
15 condition that cannot be maintained for more than a few heart beats, i.e., a few seconds, without inducing a massive pulmonary edema and a drop to zero of the cardiac output.

In another embodiment, the first frame to be introduced comprises the valvular structure and the second frame being stronger than the first  
20 one to scaffold the previously deleted stenosed aortic valve.

The advantage of this two step procedure would be to allow expansion and positioning of the frame part 10' of the IV 13 using strong pressure inflation of the balloon 26' without the risk of damaging the valvular structure 14 which, for its own expansion, would need only light  
25 pressure inflation.

The method is schematically detailed in Figures 15a to 15f. A previous dilatation of the stenosed aortic valve is performed as an initial step of the procedure to prepare the distorted valve to facilitate the following steps:

1/ positioning the double balloon catheter 40 with the first balloon 26 with the frame at the level of the aortic annulus 2a, the second IV balloon 26' being inside the left ventricle beyond the aortic annulus 2a (Figure 15a);

5           2/ compression of the stenosed aortic valve 1', 2' with the first balloon 26 having a 20 mm, preferably with a 23 mm diameter, the balloon being inflated maximally up to the bursting point, to prepare the IV insertion (Figure 15b). Inflation lasts a few seconds (preferably 10 seconds at most) with powerful pressure being used to expand the frame and forcefully  
10 embed said frame in the remains of the dilated valve;

          3/ an immediate speedy deflation of said first balloon 26 follows (Figure 15c); as soon as the balloon 26 is beginning to clearly deflate, the first frame 10 remaining attached to the stenosed valve 1', 2', the catheter 40 is withdrawn to position the IV balloon 26' inside the previously  
15 expanded frame 26 (Figure 15c in which the frame 10' is partially drawn for clarity purpose);

          4/ immediately after being well positioned, the IV balloon 26' is promptly inflated, to expand the IV 13 (Figure 15c); and

          5/ when the IV 13 is blocked inside the first frame 10, the IV balloon  
20 26' is deflated (Figure 18f).

Finally, the whole device has to be withdrawn to allow hemostasis of the femoral artery puncture hole.

The total duration of the successive steps, particularly the time during which the balloons are inflated, and the time during which the frame  
25 is expanded whereas the valve has not yet been positioned and expanded, is about 20 to 30 seconds. This is feasible if the balloons are inflated and deflated within very a few seconds, 6 to 8, for instance. This is permitted if the lumen of the shaft can be sufficiently large, taking into account the inescapable small diameter size of the shaft. This can also be facilitated by  
30 a device producing instantaneously a strong inflation or deflation pressure.

CLAIMS

1. A valve prosthesis for implantation in a body channel, the prosthesis comprising a collapsible valvular structure (14), and an  
5 expandable frame (10, 10') on which said valvular structure (14) is mounted, said valvular structure (14) being composed of a valvular tissue compatible with the human body and blood, the valvular tissue being sufficiently supple and resistant to allow said valvular structure (14) to pass  
10 from a closed state to an open state to allow a body fluid exerting pressure on the valvular structure (14) to flow, wherein said valvular tissue forms a continuous surface and is provided with guiding means formed or incorporated within, said guiding means creating stiffened zones which induce said valvular structure (14) to follow a patterned movement in its expansion to said open state and closed state, providing therefore a  
15 structure sufficiently rigid to prevent eversion.

2. The prosthetic valve according to claim 1, wherein an internal cover (19) is coupled to the valvular structure (14) and placed between said valvular structure (14) and the internal wall of the structure of the frame (10) to prevent any passage of the body fluid through said structure.

20 3. A prosthetic valve according to claim 2, wherein the internal cover is extended in its lower end by an external cover rolled upon the external wall of the structure of the frame.

4. A prosthetic valve according to claim 2 or 3, wherein both the valvular structure (14) and the cover (19) are one piece.

25 5. A prosthetic valve according to claim 2 or 3, wherein the valvular structure and/or the cover are coated with or are made of an anti-thrombic substance.

6. A prosthetic valve according to claim 2, wherein the internal cover (14) covers the full length of the internal surface of the frame (10) or  
30 only a part of said internal surface.

7. A prosthetic valve according to claim 1, wherein said valvular structure (14) has a substantially truncated hyperboloïdal shape in its open state.

8. A prosthetic valve according to claim 1, wherein said guiding means comprise strips inclined from the base (15) to the upper extremity (16) of the valvular structure (14) when compared to the central symmetry axis (XX') of the valvular structure (14), the curvature of said guiding means being concave towards said upper extremity (16) to impart an helicoidal movement to the valvular structure (14) when compared to the central axis (XX') of the valvular structure (14).

9. A prosthetic valve according to claim 8, wherein said guiding means comprise inclined pleats extending from the base (15) of the valvular structure (14) to the upper extremity (16) of said valvular structure (14).

10. A prosthetic valve according to claim 8, wherein said guiding means comprise at least 3, strengthening struts (17, 21), formed from thickened zones or incorporated strips of stiffening material.

11. A prosthetic valve according to claim 7, wherein the strips are soldered or glued on the valvular tissue.

12. A prosthetic valve according to anyone of claims 1 to 7, wherein said guiding means are rectilinear (17) in plane including the central axis (X'X) from the basis (15) to the upper extremity (16) of the valvular structure (14).

13. A prosthetic valve according to claim 12, wherein said guiding means comprise pleats extending from the base (15) of the valvular structure (14) to the upper extremity (16) of said valvular structure (14).

14. A prosthetic valve according to claim 12, wherein said guiding means comprise at least 3 strengthening struts (17, 21), formed from thickened zones or incorporated strips of stiffening material.

15. A prosthetic valve according to claim 1, wherein said stiffened zones are main parts (23) of trapezoidal shape, preferably two main parts formed symmetrically with regard to the central axis (XX') of the valvular structure (14), separated by less rigid parts (24), and in that said guiding  
5 means are of a rectilinear type.

16. A prosthetic valve according to claim 15, wherein each of said main parts (23) occupies approximately one third of the circumference of the upper part of the valvular structure (14) when this latter is in its open position.

10 17. A prosthetic valve according to claim 15, wherein the main parts (23) are thickened zones and the other parts (24) are thinner zones.

18. A prosthetic valve according to claim 1, wherein stiffened zones are a continuous of rectangular shape, completed by a flexible and foldable part to constitute the volumnar structure.

15 19. A prosthetic valve according to claim 1, wherein said valvular tissue is made of synthetic biocompatible material such as polyethylene or polyamide, or made of biological material as pericardium or porcine leaflets.

20 20. A prosthetic valve according to claim 1, wherein said valvular structure (14) is fastened to the frame (10) by sewing, by molding, soldering or by gluing, to prevent regurgitation of said body fluid between the frame (10) and the valvular structure (14).

21. A prosthetic valve according to claim 1, wherein said frame (10) is expandable from a size on the order of 4 to 5 millimeters to a size of 20  
25 to 35 mm in diameter.

22. A prosthetic valve according to claim 1, wherein said frame (10), in its fully expanded form, has a height of approximately between 10 and 15 mm and in its fully compressed frame, a height of approximately 20 mm.

23. A prosthetic valve according to claim 1, wherein said frame (10) is made in material which is distinguishable from biological tissue by non invasive imaging techniques.

24. A prosthetic valve according to claim 1, wherein said frame (10)  
5 is a foldable plastic or stainless metal structure made of intercrossing, linear bars, preferably rounded and smooth.

25. A prosthetic valve according to claim 23, wherein the size and the number of the bars are determined to give both the maximal rigidity when said frame (10) is in its expanded state and the smallest volume  
10 when the frame (10) is in its compressed state.

26. A prosthetic valve according to claim 1, wherein the frame (10) has a concave shape comprising projecting curved bars at the extremities (12).

27. A prosthetic valve according to claim 1, wherein a first frame  
15 (10) is coupled with another frame (10') which has bars of size substantially lower than said first frame (10) and which is embedded inside this latter, along a common shaft (27), the first frame being compressed with a first balloon catheter (26) and the second frame (26') being a part of a prosthetic valve (13) according to claim 1, each frame squeezed on each of  
20 the two balloons in order to constitute a sequential double balloon catheter (40).

28. A double balloon catheter according to claim 27, to separately position a first frame to be introduced in the previously dilated stenosed aortic valve and place a second frame that comprises the valvular  
25 structure, this catheter comprising two balloons fixed on a catheter shaft and separated by a few millimeters, the first balloon to be introduced being sufficiently strong to avoid bursting even at a very high inflation pressure and aimed at carrying, in its deflated state, a strong frame aimed at scaffolding the previously dilated stenosed aortic valve, the second balloon  
30 being aimed at carrying the second frame with the valvular structure.



29. A double balloon catheter according to claim 27, to separately position a first frame to be introduced in the previously dilated stenosed aortic valve that comprise the valvular structure and place a second frame, this catheter comprising two balloons fixed on a catheter shaft and  
5 separated by a few millimeters, the first balloon being aimed at carrying the second frame with the valvular structure, a strong frame aimed at scaffolding the previously dilated stenosed aortic valve, the second balloon to be introduced being sufficiently strong to avoid bursting even at a very high inflation pressure and aimed at carrying, in its deflated state,

10 30. A double balloon catheter according to claim 27, having a shaft comprising two lumens for successive and separate inflation of each balloon and an additional lumen for passage of a guide wire.

31. A method of using a two-balloon catheter with a first frame and second frame to which a valve prosthesis according to claim 1 is fastened,  
15 wherein a valve implantation is performed comprising two immediately successive steps of:

1/ expanding and positioning a first frame by inflating a first balloon (26) at a high inflation pressure,

2/ expanding and positioning a valvular structure (14) inside the  
20 frame (10') using a second balloon (26'), wherein step (2) occurs within a few seconds after step 1 and wherein a total aortic regurgitation towards the left ventricle takes place in the time interval between the two steps as an hemodynamic condition that cannot be faced for more than a few heart beats, and wherein an expansion and positioning of the frame part (10') of  
25 the IV (13) is allowed using a strong pressure inflation of the balloon (26') without risking damaging the valvular structure (14) which needs only a light pressure inflation for its own expansion

32. A method according to claim 31, wherein a previous dilatation of the stenosed aortic valve is performed as an initial step of the procedure  
30 to prepare the distorted valve to facilitate the following steps:

1/ positioning the double balloon catheter (40) with the first balloon (26) with the frame at the level of the aortic annulus (2a), the second IV balloon (26') being inside the left ventricle beyond the aortic annulus (2a);

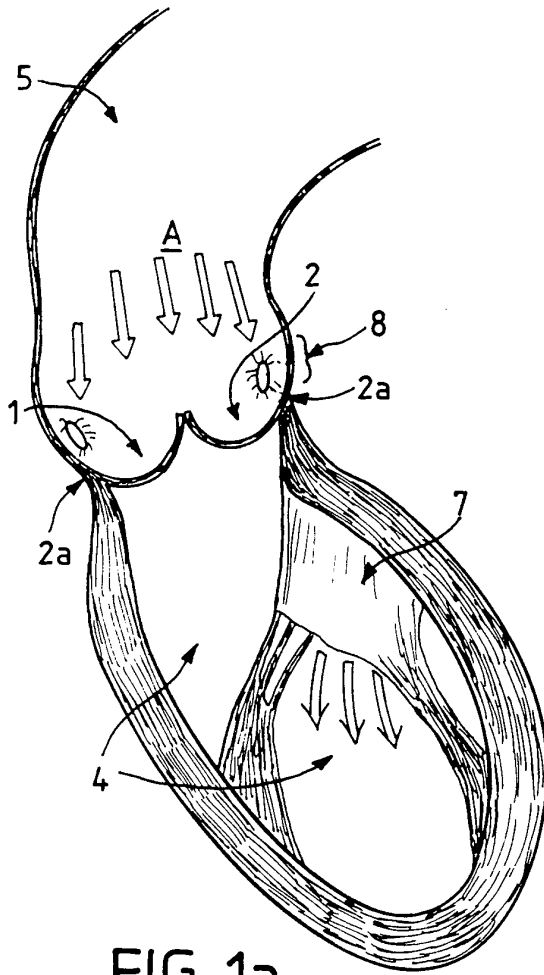
2/ compressing the stenosed aortic valve (1', 2') with the first  
5 balloon (26), the balloon being inflated maximally up to the bursting point, to prepare the IV insertion, inflation lasting a few seconds with a powerful pressure to expand the frame and forcefully embed said frame in the remains of the dilated valve, pushing away remains of the previously dilated stenosed natural valve;

10 3/ deflating immediate said first balloon (26) and; the first frame (10) remaining attached to the stenosed valve (1', 2'), the catheter (40) is pulled back to position the IV balloon (26') inside the previously expanded frame (26);

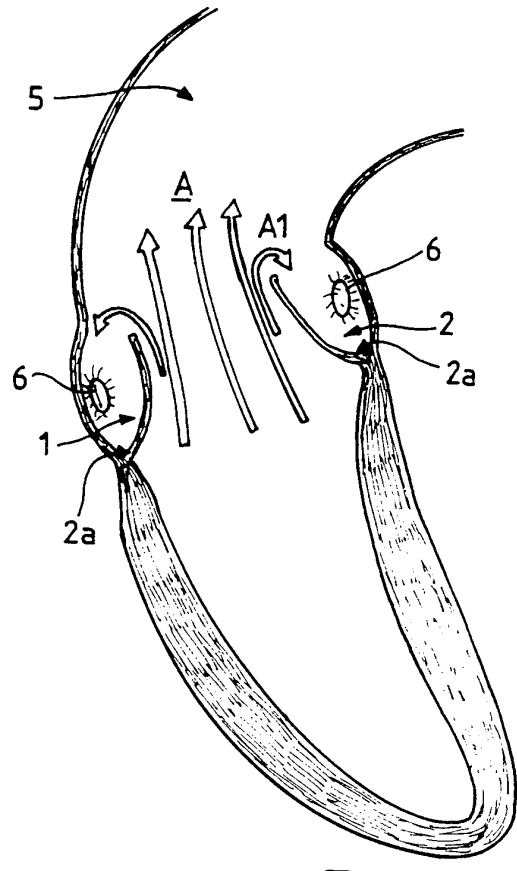
4/ immediately after being well positioned, the IV balloon (26') is  
15 promptly inflated, to expand the IV 13;

5/ when the IV 13 is blocked inside the first frame (10), the IV balloon (26') is deflated.

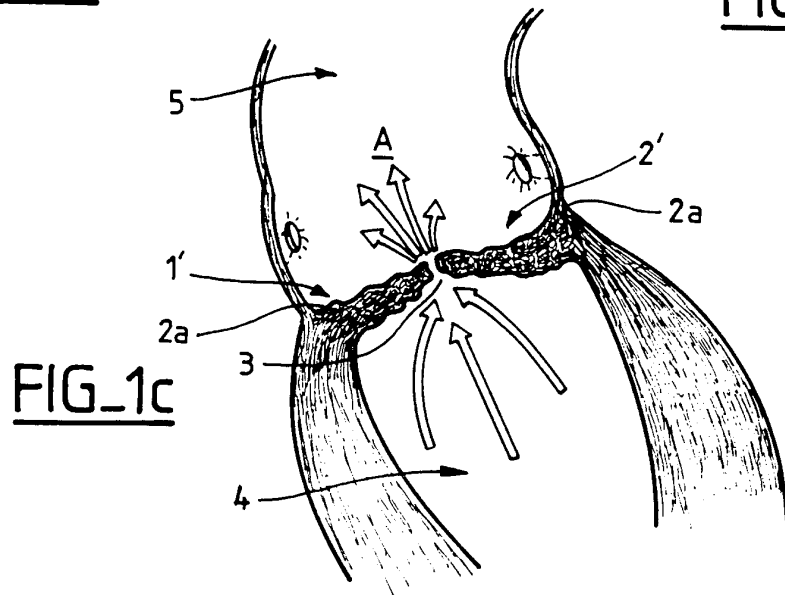
20



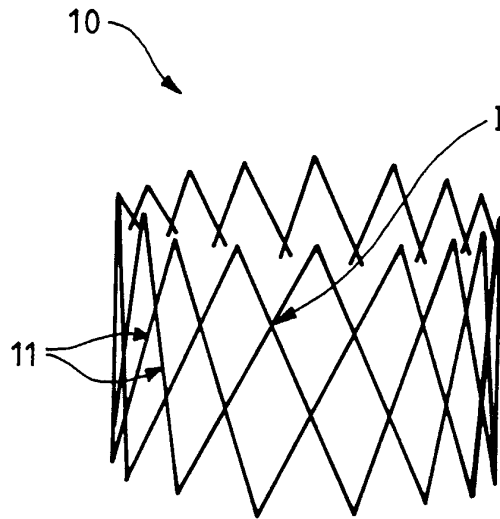
FIG\_1a



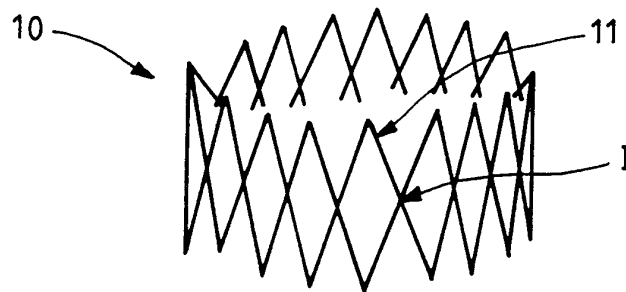
FIG\_1b



FIG\_1c



FIG\_2a



FIG\_2b

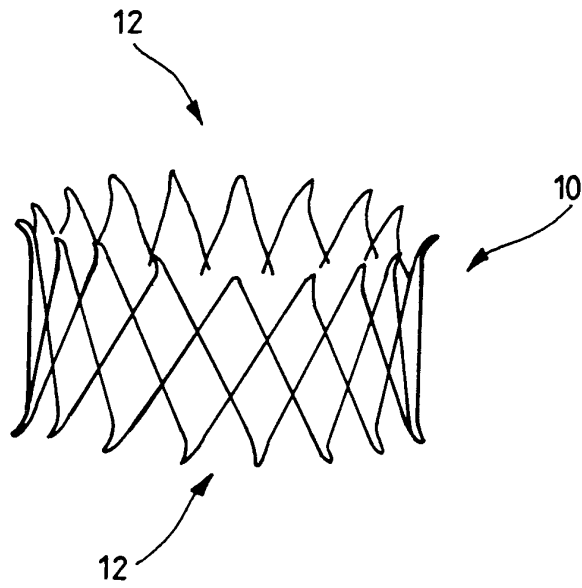


FIG. 3a

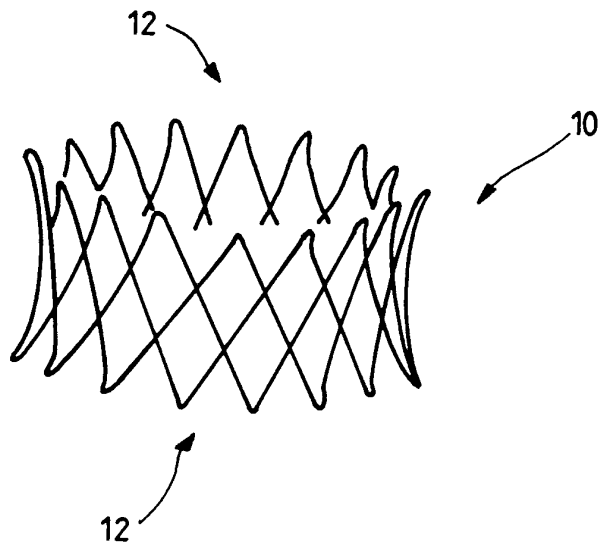
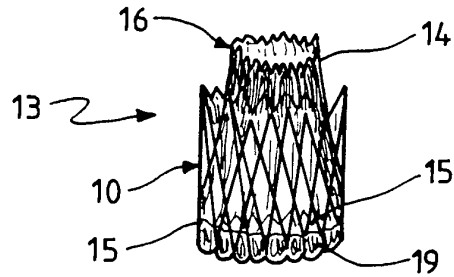
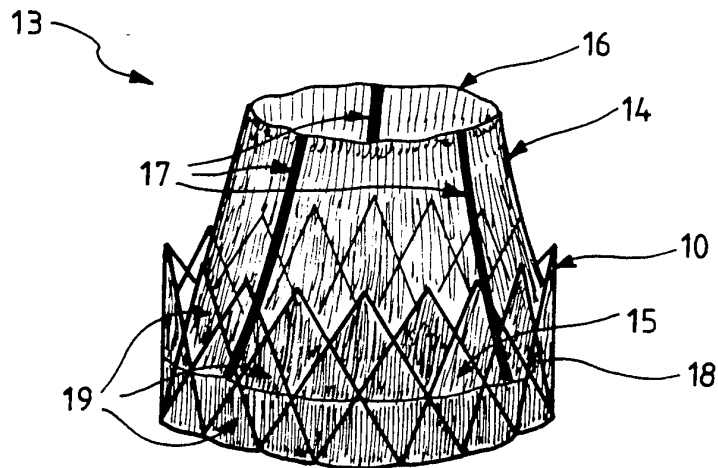


FIG. 3b

4/18

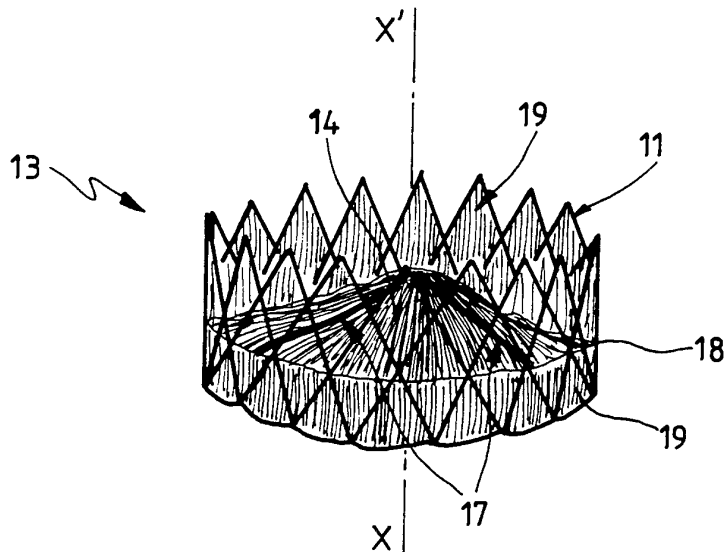


FIG\_4a

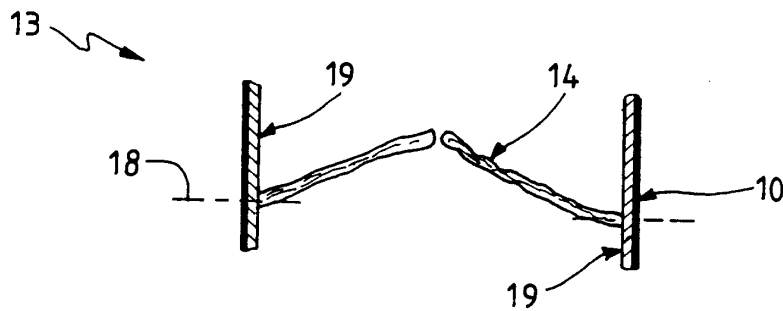


FIG\_4b

5/18

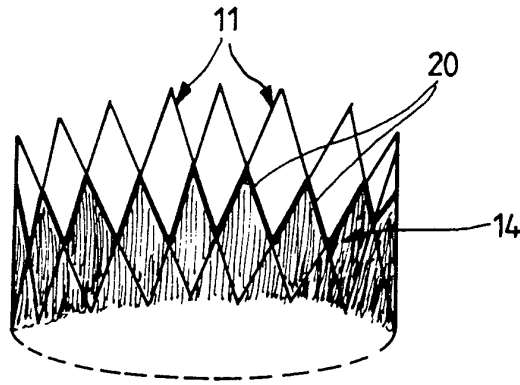


FIG\_5a

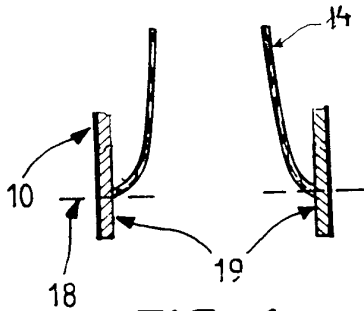


FIG\_5b

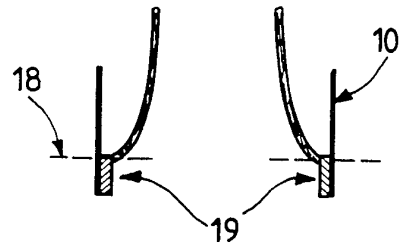
6/18



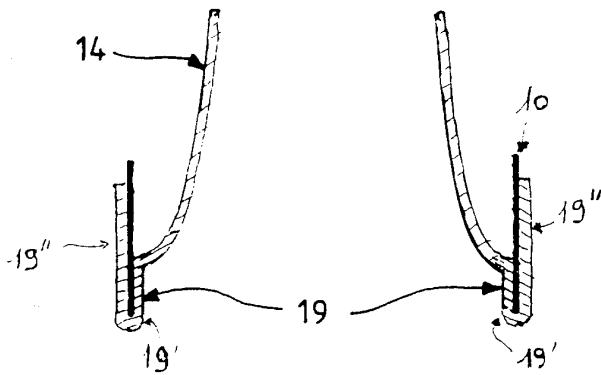
FIG\_7



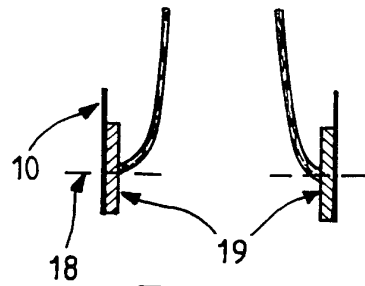
FIG\_6a



FIG\_6b

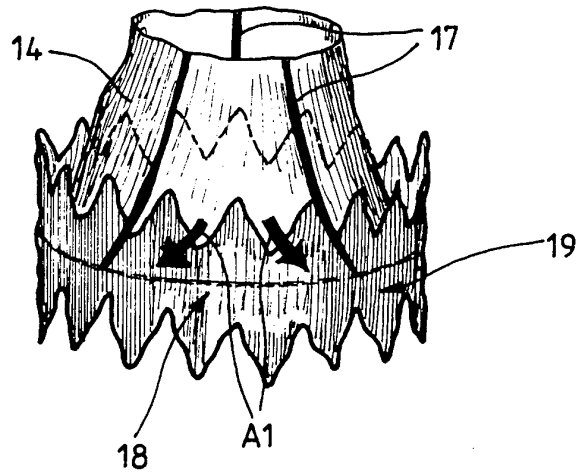


FIG\_6d

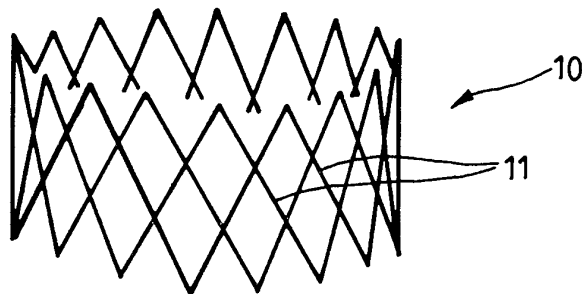


FIG\_6c



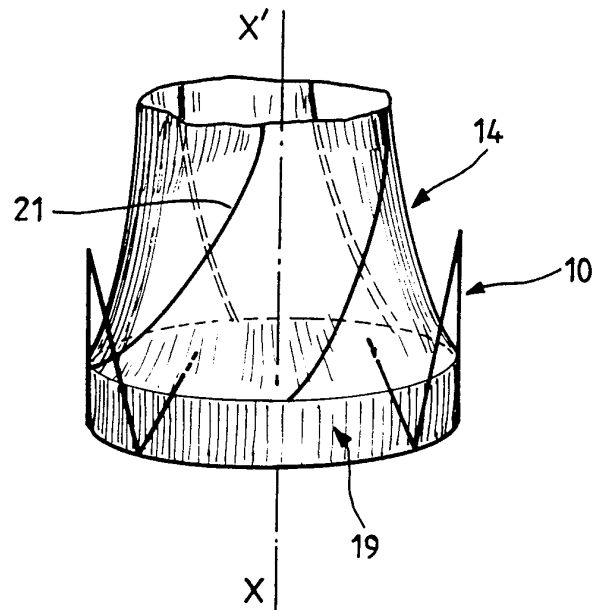


FIG\_8a

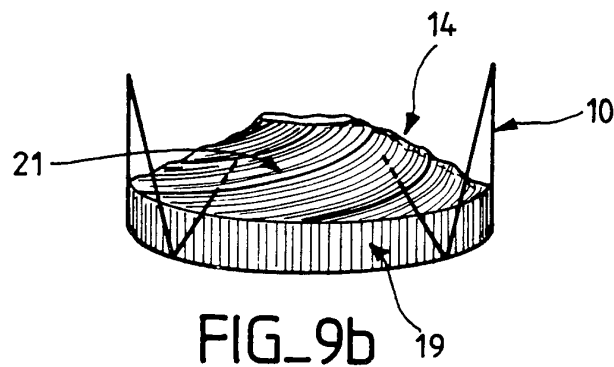


FIG\_8b

8/18

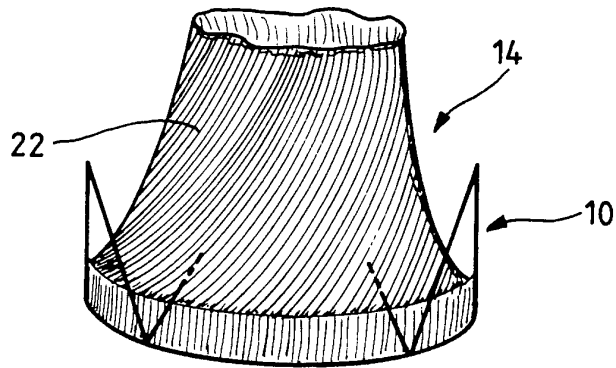


FIG\_9a

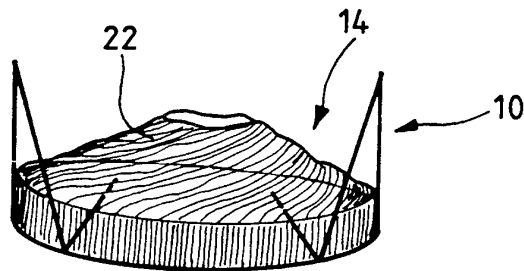


FIG\_9b

9/18

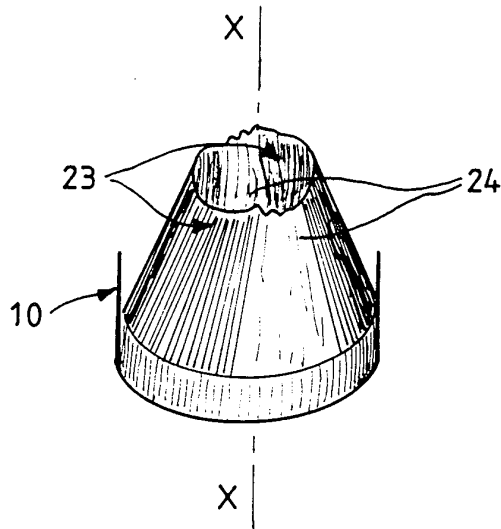


FIG\_10a

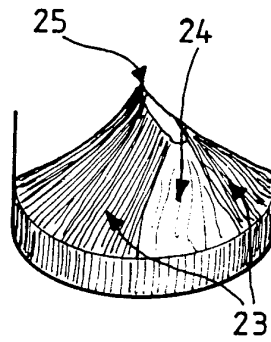


FIG\_10b

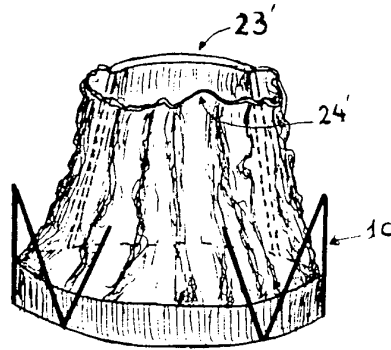
10/18



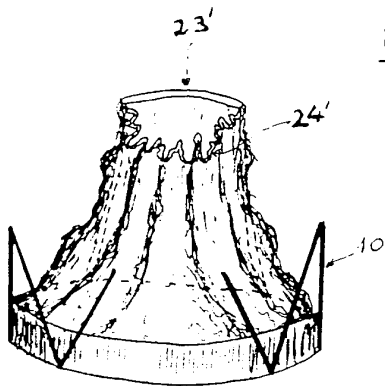
FIG\_11a



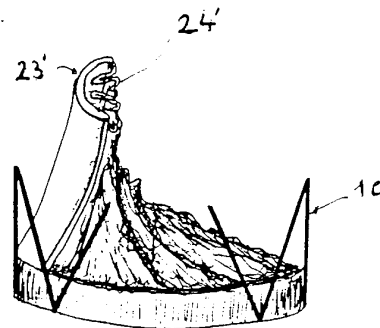
FIG\_11b



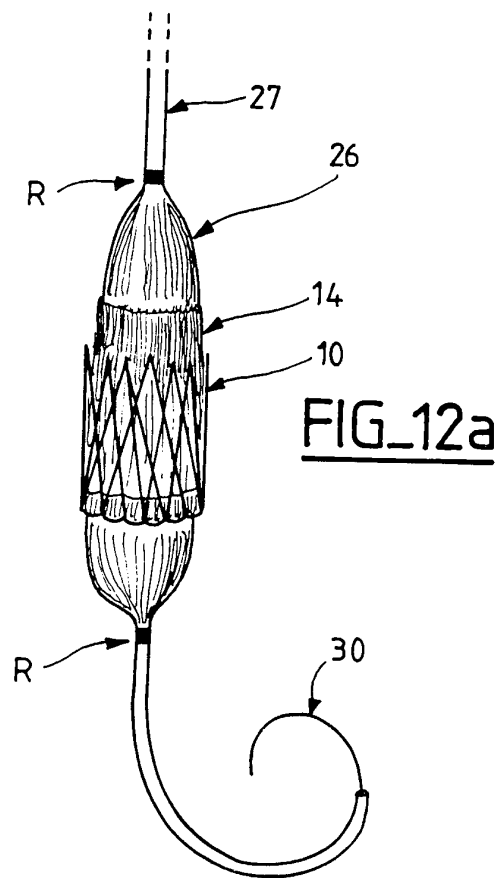
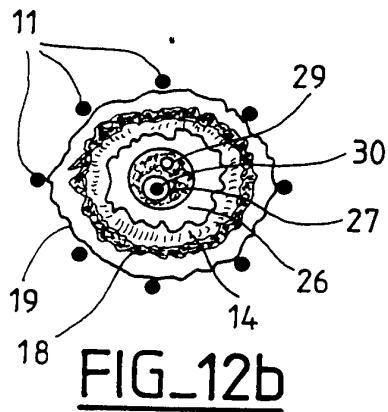
FIG\_11c



FIG\_11d



FIG\_11e



12/18

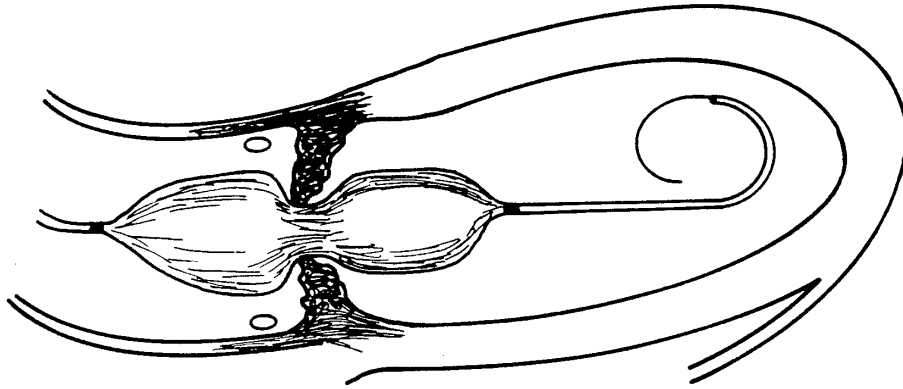


FIG-13C

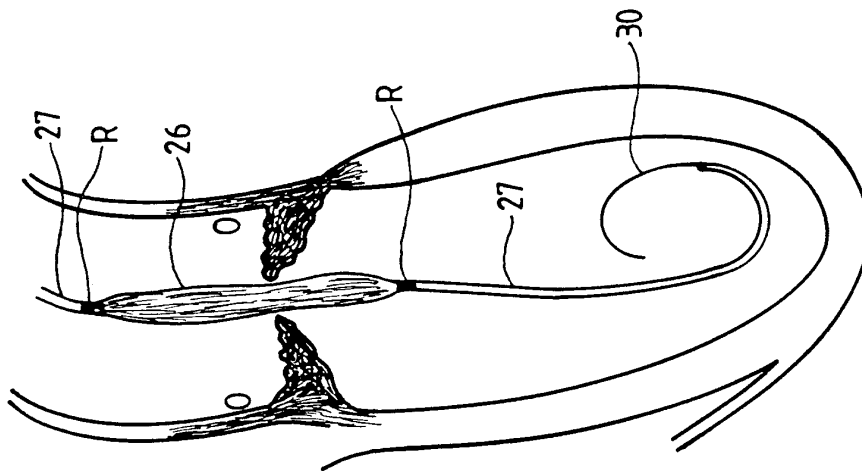


FIG-13b

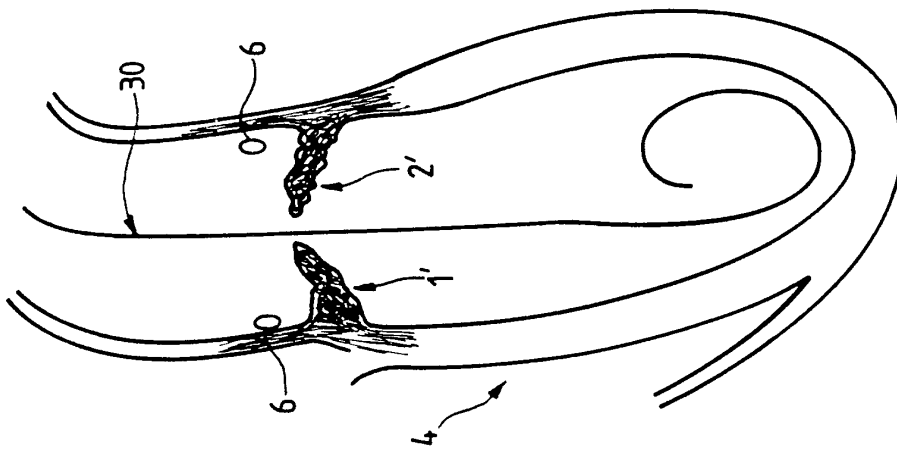


FIG-13a

13/18

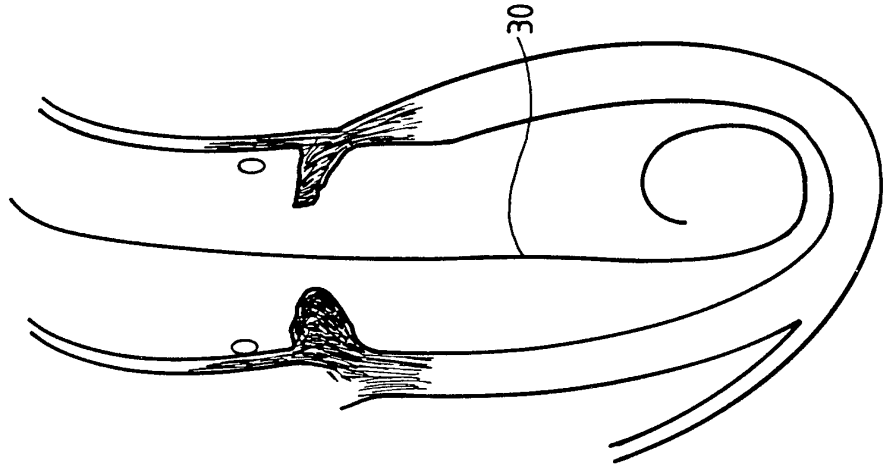


FIG-13f

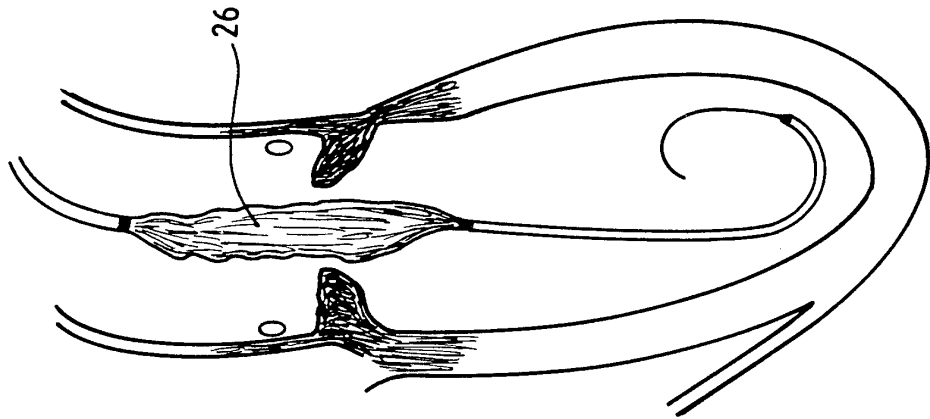


FIG-13e

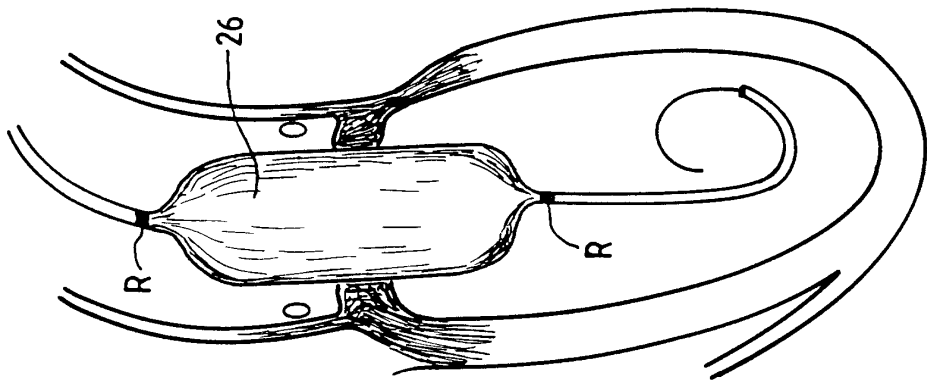


FIG-13d

14/18

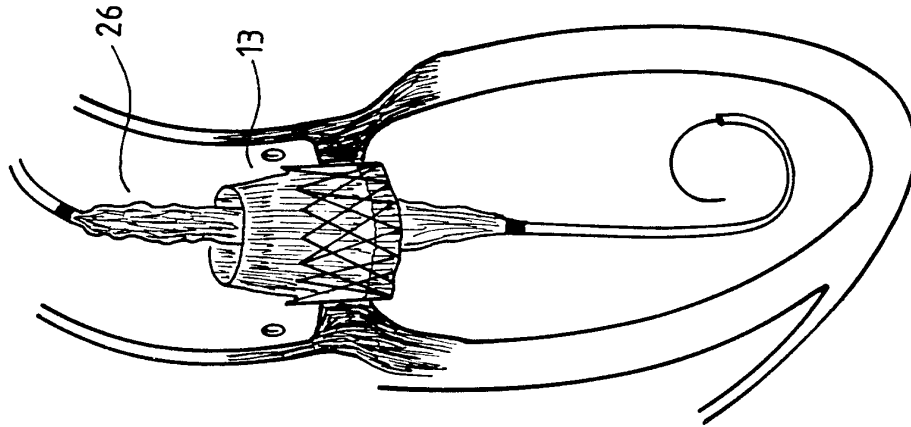


FIG-13i

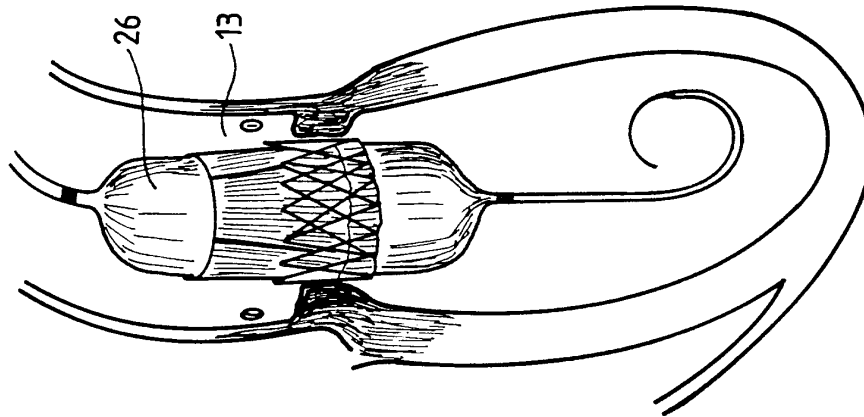


FIG-13h

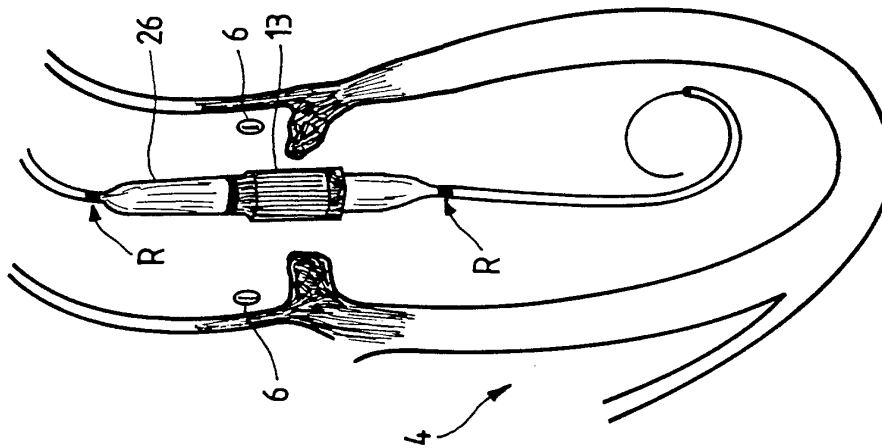


FIG-13g



15/18

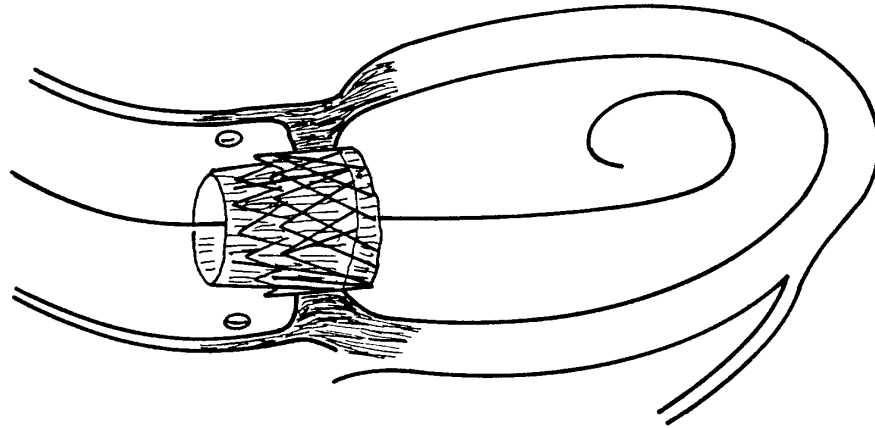


FIG-13I

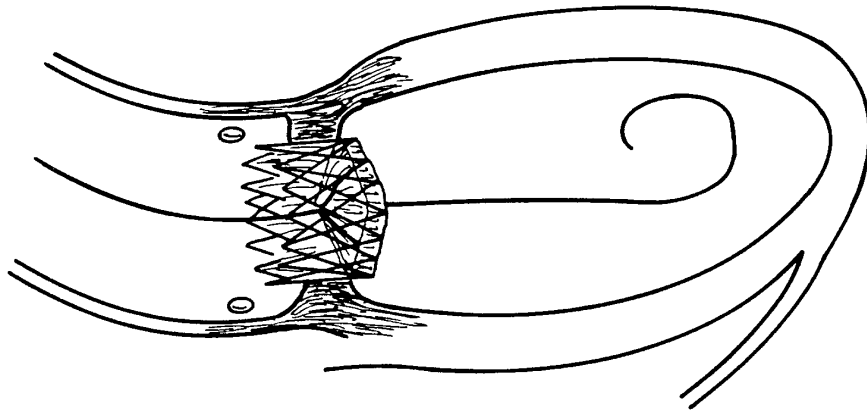


FIG-13K

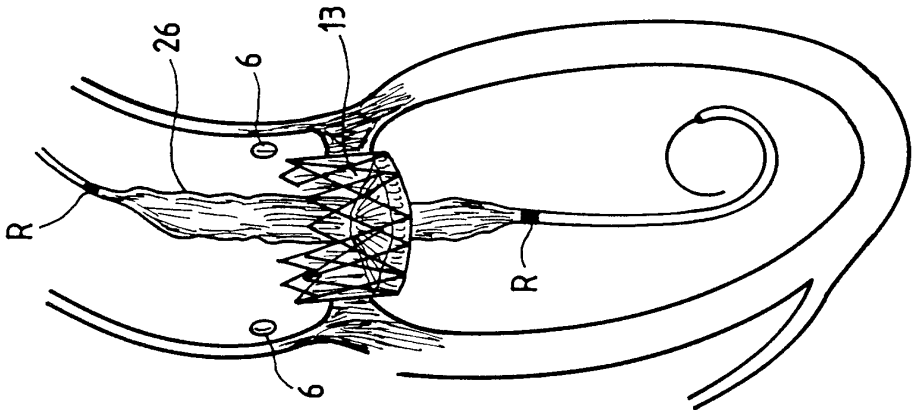
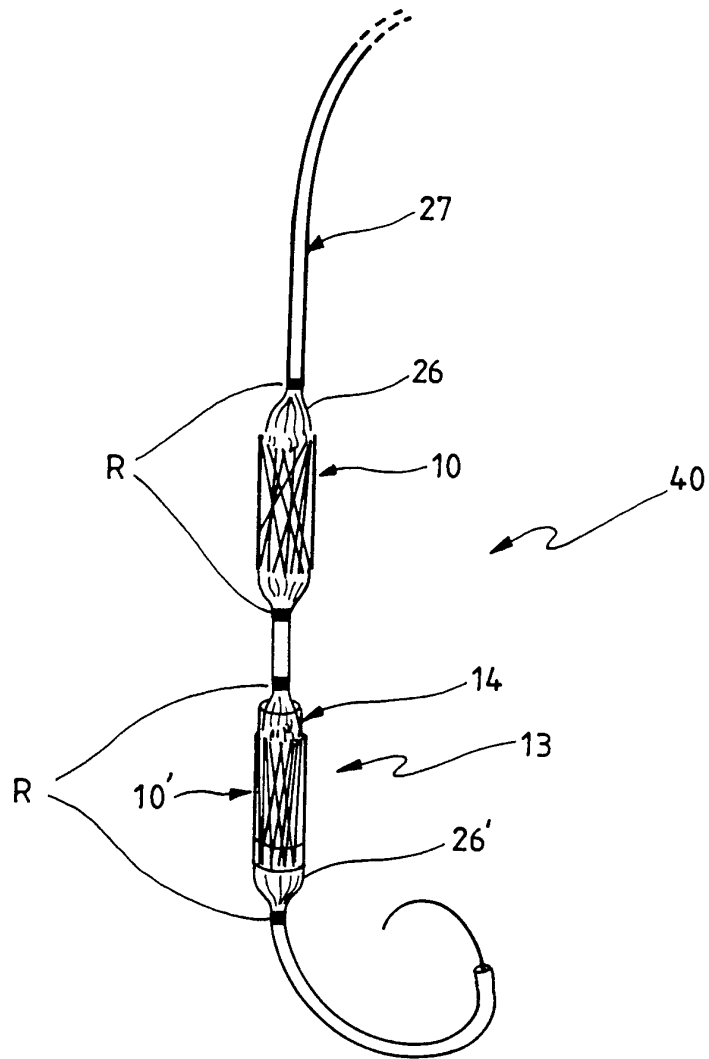


FIG-13J

FIG\_14



17/18

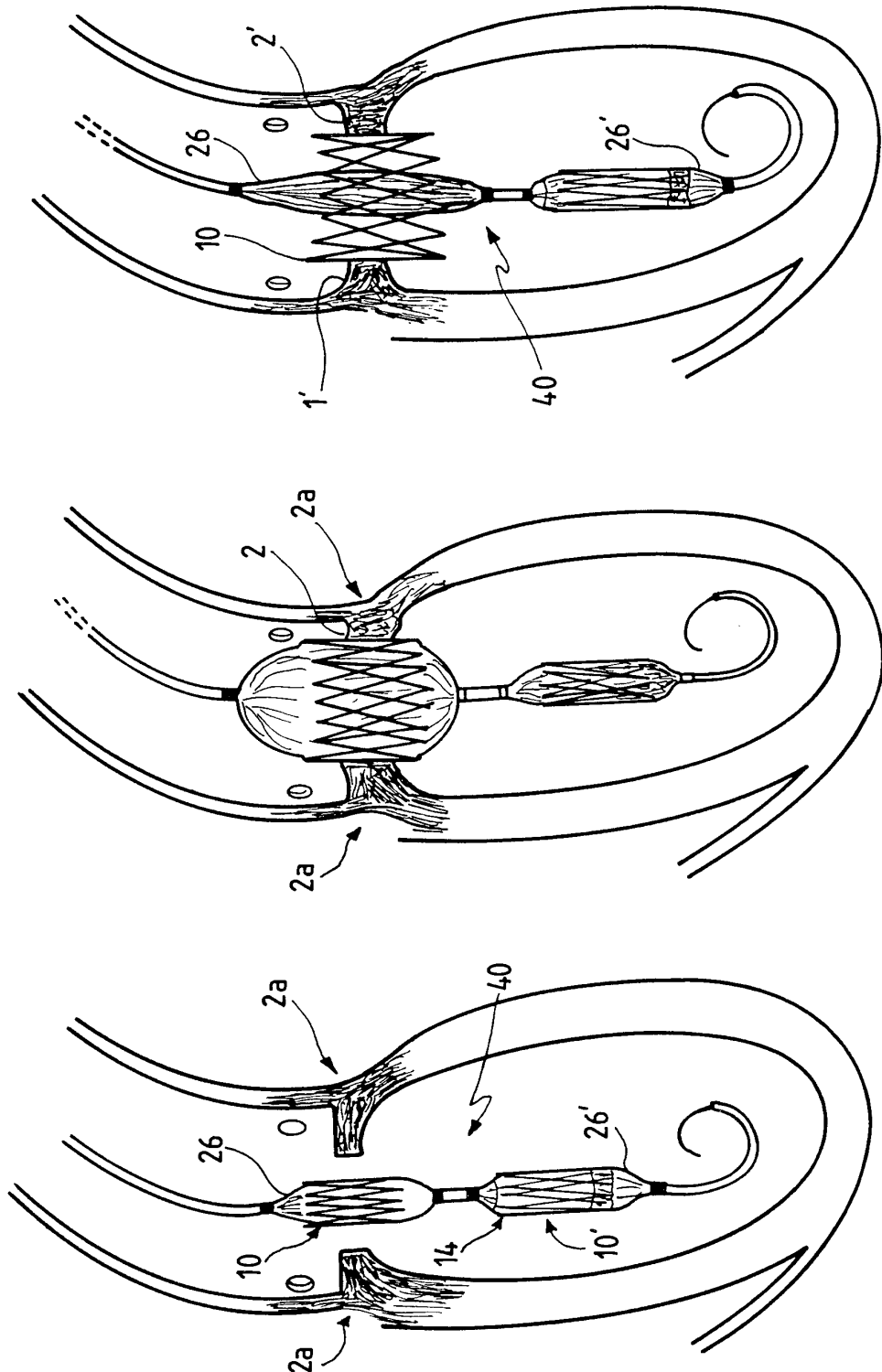


FIG-15c

FIG-15b

FIG-15a

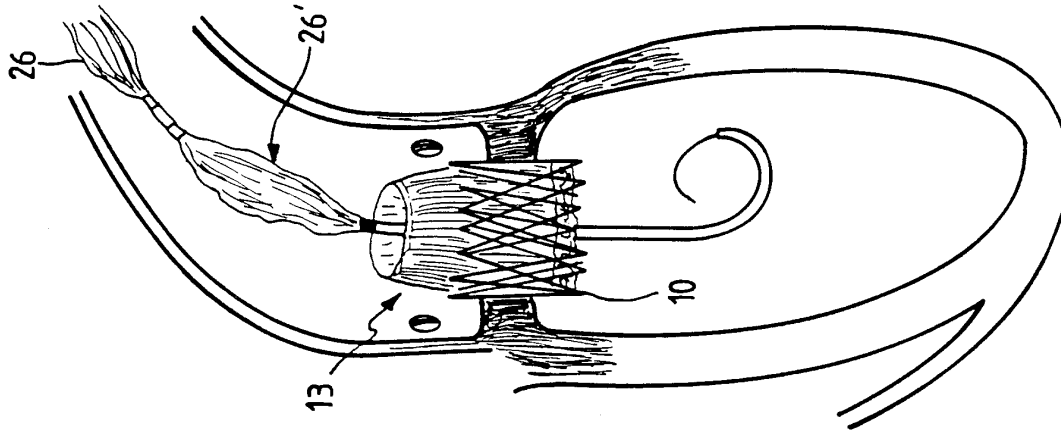


FIG-15f

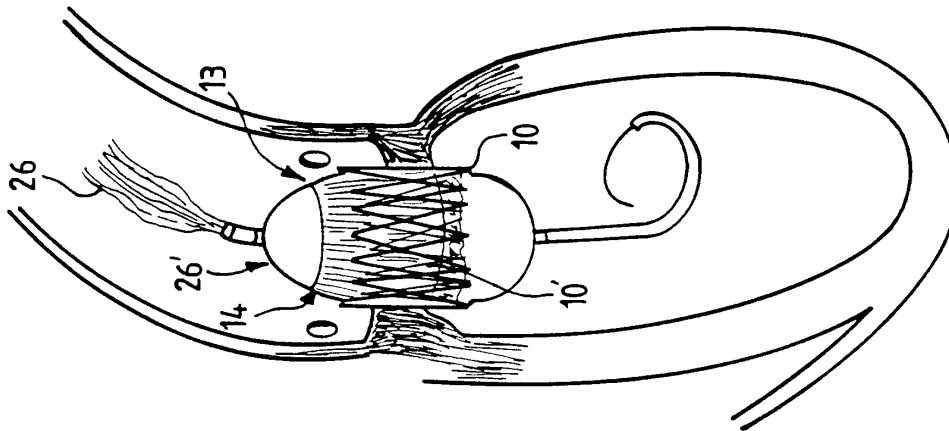


FIG-15e

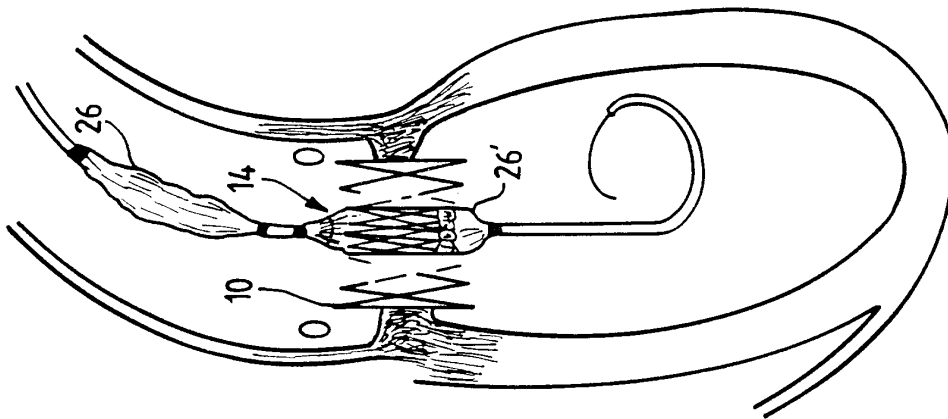


FIG-15d

# INTERNATIONAL SEARCH REPORT

International Application No  
PCT/EP 97/07337

**A. CLASSIFICATION OF SUBJECT MATTER**  
IPC 6 A61F2/24

According to International Patent Classification (IPC) or to both national classification and IPC

**B. FIELDS SEARCHED**

Minimum documentation searched (classification system followed by classification symbols)  
IPC 6 A61F

Documentation searched other than minimum documentation to the extent that such documents are included in the fields searched

Electronic data base consulted during the international search (name of data base and, where practical, search terms used)

**C. DOCUMENTS CONSIDERED TO BE RELEVANT**

Category °	Citation of document, with indication, where appropriate, of the relevant passages	Relevant to claim No.
X	US 5 411 552 A (ANDERSEN HENNING R ET AL) 2 May 1995 cited in the application see column 5, line 9 - column 6, line 39; claims; figures	1, 19, 20, 23-25
A	---	7, 10, 12, 14, 21
A	WO 93 01768 A (STEVENS JOHN H) 4 February 1993 -----	1, 7, 19, 23, 24

Further documents are listed in the continuation of box C.

Patent family members are listed in annex.

° Special categories of cited documents :

- \*A\* document defining the general state of the art which is not considered to be of particular relevance
- \*E\* earlier document but published on or after the international filing date
- \*L\* document which may throw doubts on priority claim(s) or which is cited to establish the publication date of another citation or other special reason (as specified)
- \*O\* document referring to an oral disclosure, use, exhibition or other means
- \*P\* document published prior to the international filing date but later than the priority date claimed

- \*T\* later document published after the international filing date or priority date and not in conflict with the application but cited to understand the principle or theory underlying the invention
- \*X\* document of particular relevance; the claimed invention cannot be considered novel or cannot be considered to involve an inventive step when the document is taken alone
- \*Y\* document of particular relevance; the claimed invention cannot be considered to involve an inventive step when the document is combined with one or more other such documents, such combination being obvious to a person skilled in the art.
- \*&\* document member of the same patent family

Date of the actual completion of the international search

6 May 1998

Date of mailing of the international search report

19.05.98

Name and mailing address of the ISA  
European Patent Office, P.B. 5818 Patentlaan 2  
NL - 2280 HV Rijswijk  
Tel. (+31-70) 340-2040, Tx. 31 651 epo nl,  
Fax: (+31-70) 340-3016

Authorized officer  
  
Neumann, E

**INTERNATIONAL SEARCH REPORT**

International application No.  
PCT/EP 97/07337

**Box I Observations where certain claims were found unsearchable (Continuation of item 1 of first sheet)**

This International Search Report has not been established in respect of certain claims under Article 17(2)(a) for the following reasons:

1.  Claims Nos.: 31, 32  
because they relate to subject matter not required to be searched by this Authority, namely:  
Rule 39.1(iv) PCT - Method for treatment of the human or animal body by surgery
2.  Claims Nos.:  
because they relate to parts of the International Application that do not comply with the prescribed requirements to such an extent that no meaningful International Search can be carried out, specifically:
3.  Claims Nos.:  
because they are dependent claims and are not drafted in accordance with the second and third sentences of Rule 6.4(a).

**Box II Observations where unity of invention is lacking (Continuation of item 2 of first sheet)**

This International Searching Authority found multiple inventions in this international application, as follows:

1.  As all required additional search fees were timely paid by the applicant, this International Search Report covers all searchable claims.
2.  As all searchable claims could be searched without effort justifying an additional fee, this Authority did not invite payment of any additional fee.
3.  As only some of the required additional search fees were timely paid by the applicant, this International Search Report covers only those claims for which fees were paid, specifically claims Nos.:
4.  No required additional search fees were timely paid by the applicant. Consequently, this International Search Report is restricted to the invention first mentioned in the claims; it is covered by claims Nos.:

**Remark on Protest**

- The additional search fees were accompanied by the applicant's protest.
- No protest accompanied the payment of additional search fees.

# INTERNATIONAL SEARCH REPORT

Information on patent family members

International Application No

PCT/EP 97/07337

Patent document cited in search report	Publication date	Patent family member(s)	Publication date
US 5411552     A	02-05-1995	AU 7972691 A	10-12-1991
		DE 69113818 D	16-11-1995
		DE 69113818 T	05-06-1996
		WO 9117720 A	28-11-1991
		EP 0592410 A	20-04-1994
-----			
WO 9301768     A	04-02-1993	US 5370685 A	06-12-1994
		AU 668690 B	16-05-1996
		AU 2412792 A	23-02-1993
		CA 2113476 A	04-02-1993
		EP 0597967 A	25-05-1994
		JP 6511167 T	15-12-1994
		US 5545214 A	13-08-1996
		US 5584803 A	17-12-1996
		US 5558644 A	24-09-1996
		US 5702368 A	30-12-1997
US 5738652 A	14-04-1998		
-----			

CORRECTED  
VERSION\*

PCT

WORLD INTELLECTUAL PROPERTY ORGANIZATION  
International Bureau



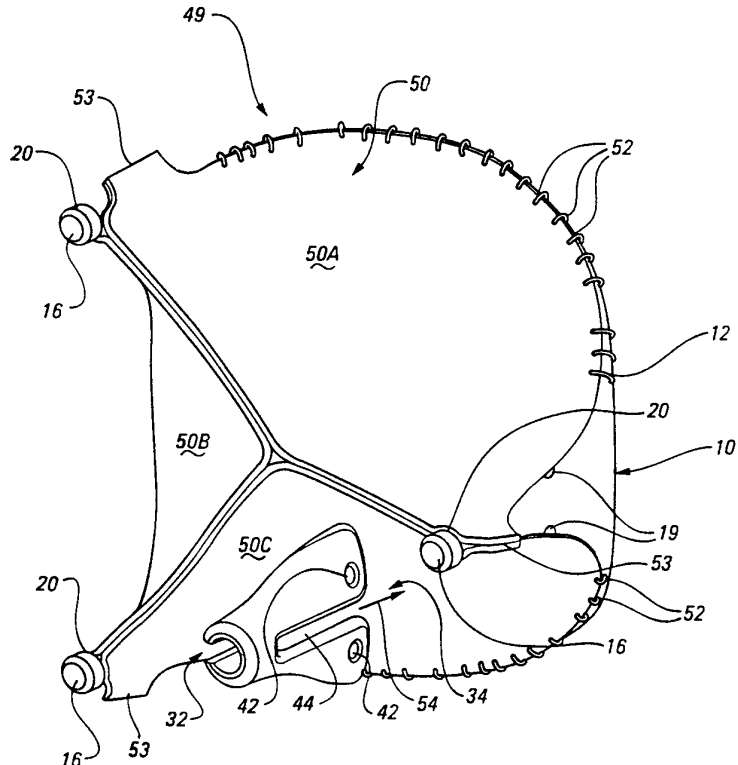
INTERNATIONAL APPLICATION PUBLISHED UNDER THE PATENT COOPERATION TREATY (PCT)

<p>(51) International Patent Classification <sup>6</sup> : <b>A61F 2/24</b></p>	<p><b>A1</b></p>	<p>(11) International Publication Number: <b>WO 99/30646</b> (43) International Publication Date: 24 June 1999 (24.06.99)</p>
<p>(21) International Application Number: PCT/US98/26173 (22) International Filing Date: 9 December 1998 (09.12.98) (30) Priority Data: 08/992,595 17 December 1997 (17.12.97) US (71) Applicant: ST. JUDE MEDICAL, INC. [US/US]; One Lillehei Plaza, St. Paul, MN 55117 (US). (72) Inventors: REIMINK, Matthew, S.; 217 West Nebraska Avenue #216, St. Paul, MN 55117 (US). SCHROEDER, Richard, F.; 4675 Gershwin Avenue North, Oakdale, MN 55128 (US). MIRSCH, M., William, II; 2950 Fernwood Street, Roseville, MN 55113 (US). GIRARD, Michael, J.; 6318 White Owl Drive, Lino Lakes, MN 55014 (US). (74) Agents: CHAMPLIN, Judson, K.; Westman, Champlin &amp; Kelly, P.A., Suite 1600 – International Centre, 900 Second Avenue South, Minneapolis, MN 55402–3319 (US) et al.</p>		<p>(81) Designated States: AL, AM, AT, AU, AZ, BA, BB, BG, BR, BY, CA, CH, CN, CU, CZ, DE, DK, EE, ES, FI, GB, GD, GE, GH, GM, HU, ID, IL, IN, IS, JP, KE, KG, KP, KR, KZ, LC, LK, LR, LS, LT, LU, LV, MD, MG, MK, MN, MW, MX, NO, NZ, PL, PT, RO, RU, SD, SE, SG, SI, SK, SL, TJ, TM, TR, TT, UA, UG, UZ, VN, YU, ZW, ARIPO patent (GH, GM, KE, LS, MW, SD, SZ, UG, ZW), Eurasian patent (AM, AZ, BY, KG, KZ, MD, RU, TJ, TM), European patent (AT, BE, CH, CY, DE, DK, ES, FI, FR, GB, GR, IE, IT, LU, MC, NL, PT, SE), OAPI patent (BF, BJ, CF, CG, CI, CM, GA, GN, GW, ML, MR, NE, SN, TD, TG).</p> <p><b>Published</b> <i>With international search report.</i></p>

(54) Title: PROSTHETIC HEART VALVE STENT UTILIZING MOUNTING CLIPS

(57) Abstract

A prosthetic heart valve is provided having a stent (10) and a piece of biocompatible material (50). The stent (10) includes an inflow ring (12) and a plurality of posts (14), each post (14) extending from the ring (12) to a post tip (16). The piece of material (50) extends over the stent (10) and substantially conforms to a profile of the stent (10). The piece of material (50) includes a portion which extends adjacent a post tip (16). A clip (30) is provided which has a shape generally conforming to the post tip (16) to thereby clamp the portion of the piece of material (50) to the post tip (16).



\*(Referred to in PCT Gazette No. 38/1999, Section II)



**FOR THE PURPOSES OF INFORMATION ONLY**

Codes used to identify States party to the PCT on the front pages of pamphlets publishing international applications under the PCT.

<b>AL</b>	Albania	<b>ES</b>	Spain	<b>LS</b>	Lesotho	<b>SI</b>	Slovenia
<b>AM</b>	Armenia	<b>FI</b>	Finland	<b>LT</b>	Lithuania	<b>SK</b>	Slovakia
<b>AT</b>	Austria	<b>FR</b>	France	<b>LU</b>	Luxembourg	<b>SN</b>	Senegal
<b>AU</b>	Australia	<b>GA</b>	Gabon	<b>LV</b>	Latvia	<b>SZ</b>	Swaziland
<b>AZ</b>	Azerbaijan	<b>GB</b>	United Kingdom	<b>MC</b>	Monaco	<b>TD</b>	Chad
<b>BA</b>	Bosnia and Herzegovina	<b>GE</b>	Georgia	<b>MD</b>	Republic of Moldova	<b>TG</b>	Togo
<b>BB</b>	Barbados	<b>GH</b>	Ghana	<b>MG</b>	Madagascar	<b>TJ</b>	Tajikistan
<b>BE</b>	Belgium	<b>GN</b>	Guinea	<b>MK</b>	The former Yugoslav Republic of Macedonia	<b>TM</b>	Turkmenistan
<b>BF</b>	Burkina Faso	<b>GR</b>	Greece			<b>TR</b>	Turkey
<b>BG</b>	Bulgaria	<b>HU</b>	Hungary	<b>ML</b>	Mali	<b>TT</b>	Trinidad and Tobago
<b>BJ</b>	Benin	<b>IE</b>	Ireland	<b>MN</b>	Mongolia	<b>UA</b>	Ukraine
<b>BR</b>	Brazil	<b>IL</b>	Israel	<b>MR</b>	Mauritania	<b>UG</b>	Uganda
<b>BY</b>	Belarus	<b>IS</b>	Iceland	<b>MW</b>	Malawi	<b>US</b>	United States of America
<b>CA</b>	Canada	<b>IT</b>	Italy	<b>MX</b>	Mexico	<b>UZ</b>	Uzbekistan
<b>CF</b>	Central African Republic	<b>JP</b>	Japan	<b>NE</b>	Niger	<b>VN</b>	Viet Nam
<b>CG</b>	Congo	<b>KE</b>	Kenya	<b>NL</b>	Netherlands	<b>YU</b>	Yugoslavia
<b>CH</b>	Switzerland	<b>KG</b>	Kyrgyzstan	<b>NO</b>	Norway	<b>ZW</b>	Zimbabwe
<b>CI</b>	Côte d'Ivoire	<b>KP</b>	Democratic People's Republic of Korea	<b>NZ</b>	New Zealand		
<b>CM</b>	Cameroon	<b>KR</b>	Republic of Korea	<b>PL</b>	Poland		
<b>CN</b>	China	<b>KZ</b>	Kazakstan	<b>PT</b>	Portugal		
<b>CU</b>	Cuba	<b>LC</b>	Saint Lucia	<b>RO</b>	Romania		
<b>CZ</b>	Czech Republic	<b>LI</b>	Liechtenstein	<b>RU</b>	Russian Federation		
<b>DE</b>	Germany	<b>LK</b>	Sri Lanka	<b>SD</b>	Sudan		
<b>DK</b>	Denmark	<b>LR</b>	Liberia	<b>SE</b>	Sweden		
<b>EE</b>	Estonia			<b>SG</b>	Singapore		

-1-

**PROSTHETIC HEART VALVE STENT UTILIZING  
MOUNTING CLIPS**

FIELD OF THE INVENTION

The present invention relates to prosthetic heart valves. More specifically, the present invention relates to attaching a biocompatible material to a stent for a prosthetic heart valve.

BACKGROUND OF THE INVENTION

Prosthetic heart valves have been used for replacing damaged heart valves in patients. Various types of prosthetic heart valves are known, including mechanical heart valves and bioprosthetic heart valves. One group of prosthetic heart valves may include a material such as tissue or synthetic polymers carried on a stent. The material typically comprises animal tissue such as porcine aortic valve material or bovine pericardium.

Various techniques are known for coupling the material to the stent. For example, suturing the valve material to the stent is one common technique used to couple the material to the stent. However, such suturing has been found to place stress on the material as the valve opens and closes, thus leading to a shorter useful life for the prosthetic heart valve. In fact, any attachment technique which creates a hole in the tissue near the post tips will concentrate destructive stresses in those areas.

Other types of attachment techniques are also shown in the prior art. For example, U.S. Patent No. 4,501,030, issued February 26, 1985, entitled "METHOD OF LEAFLET ATTACHMENT FOR PROSTHETIC HEART VALVES" describes the use of a clamping force to hold the material to the

-2-

stent. However, the design uses sutures which are positioned near the top of each of the stent posts. Further, U.S. Patent No. 4,501,030 focuses the clamping force in a small region of the material between the thin wire stent and a polymer clamping piece. By further concentrating the clamping force, the valve may be more likely to require early replacement. It may be possible to improve the performance of this device by increasing the area over which the clamping force is applied. In addition, this device applies stress to the leaflet material in direct relation to the closing load of the valve. U.S. Patent No. 4,441,216 issued April 10, 1984, entitled "TISSUE HEART VALVE AND STENT" describes the use of sutures along the top of each of the stent posts in order to attach the material to the stent. U.S. Patent Nos. 5,163,955, 5,423,887 and 5,489,298 to Love all describe the use of alignment members at the tops of the posts. These alignment members put holes into the material. Further, the designs of Love are relatively complicated in that they require several pieces and use an inner and an outer stent which adds considerable thickness to the device. Similar problems are encountered in U.S. Patent No. 4,725,274, to Lane which issued February 16, 1988. The Lane patent requires four separate stent components which, when assembled, create a relatively thick stent.

#### SUMMARY OF THE INVENTION

The present invention includes a prosthetic heart valve having a stent and one or more pieces of biocompatible material which generally comprises leaflets or cusps. The stent includes an inflow ring and a plurality of posts. Each post extends from the ring to a post tip. The leaflets extend over the stent and

-3-

substantially conform to a profile of the stent. The material includes a portion which extends adjacent a post tip. A clip is provided which has a shape generally conforming to the post to thereby clamp the portion of the material to the post tip. The clips reduce the stress applied to the leaflets during opening and closing of the valve. One aspect of the invention includes providing knobs at the ends of the post tips to maintain the clip in position.

#### BRIEF DESCRIPTION OF THE DRAWINGS

Figure 1 is a perspective view of a stent in accordance with the present invention.

Figure 2 is a perspective view of a commissure post clip for use with the stent of Figure 1 in accordance with the present invention.

Figure 3 is a perspective view showing three commissure post clips of the type shown in Figure 2 coupled to posts of the stent shown in Figure 1.

Figure 4 is a perspective view of a prosthetic valve including a commissure post clip of Figure 2.

Figure 5 is a side plan view showing commissure post clips securing material to the stent of Figure 1.

Figure 6A is a top plan view of a commissure post clip coupling material to a stent in which the material is in an open position.

Figure 6B is a top plan view of a commissure post clip coupling material to a stent in which the material is in a closed position.

#### DETAILED DESCRIPTION OF THE PREFERRED EMBODIMENTS

Figure 1 is a perspective view of a stent 10 in accordance with the present invention. Stent 10 includes an inflow ring 12 which may be scalloped and

-4-

commissure posts 14 extending therefrom to individual post tips 16. As shown in Figure 1, stent 10 provides a relatively smooth profile for carrying cusps or leaflets made of biocompatible material (not shown in Figure 1) which will hereinafter be referred to as leaflets. Stent 10 includes openings 18 and retaining holes 19 formed therein which are used to couple material (not shown in Figure 1) to the stent. Post tip knobs 20 are carried at tips 16 of each of the commissure posts 14. Preferably, stent 10 is formed of a biocompatible material such as polyetheretherketone (PEEK).

Figure 2 is a perspective view of a commissure post clamp or clip 30 in accordance with one embodiment of the present invention. Commissure post clip 30 includes tip region 32, base region 34, inner side wall 36 and outer side wall 38. Inner wall 36 of clip 30 is generally formed in the shape of a C-shape and is configured to fit over posts 14 of stent 10 shown in Figure 1 adjacent tips 16. The general C-shape of clip 30 is formed by end walls 40 which extend from tip region 32 to base region 34. Additionally, retaining holes 42 are formed in clip 30 near base region 34. Retaining holes 42 are located such that they are generally in alignment with retaining holes 19 of stent 10 when clip 30 is positioned over post 14. Clip 30 includes segmented region 44 to allow spreading between clip portions 46 and 48.

Figure 3 is a perspective view of stent 10 including three commissure post clips 30 coupled to each post 14. For simplicity, the leaflets are not shown in Figure 3. As shown in Figure 3, clips 30 have a shape which is configured to generally conform to the profile of posts 14. Further, post tip knobs 20 positioned at

-5-

tips 16 of posts 14 secure clips 30 on posts 14. Retaining holes 42 are substantially aligned with retaining holes 19 whereby an attachment mechanism, such as a suture (not shown in Figure 3) can be secured proximate the base region 34 of clip 30 to couple clip 30 to a post 14. Relative pre-assembly spacing and alignment of retaining holes 19 on stent 10 and retaining holes 42 on clip 30 can be varied to adjust clamping force.

Figure 4 is an exploded view of a heart valve prosthesis 49 having stent 10 and clip 30 including leaflets 50 carried thereon. Leaflets may be a single piece or multiple pieces. In one embodiment, leaflets 50 are formed of three separate material pieces, 50A, 50B and 50C which are sewn to ring 12 using suture 52. Leaflets 50 extend over post 14 and form leaflet tabs 53 which are located generally at the tip 16 of post 14. As shown in Figure 4, commissure post clip 30 is aligned generally coaxially with post 14 and moved in a direction shown by arrow 54. As clip 30 is moved over post 14, segmented region 44 allows clip 30 to spread such that it will securely fit over post 14 and post tip knob 20.

Figure 5 is a side plan view of prosthetic heart valve 49 in accordance with the present invention including clips 30 coupled to posts 14 of stent 10. As shown in Figure 5, clips 30 are secured to posts 14 using suture 60 which extends through retaining holes 42 and retaining holes 19 (not shown in Figure 5). Leaflet tabs 53 fit in segmented region 44. As exemplified in Figure 5, clips 30 secure leaflets 50 to posts 14 of stent 10. Further, the securing of material 50 to post 14 places only limited stress on the leaflets. Such stress is spread out over a relatively large area and requires no

-6-

sutures near post tip 16.

Figures 6A and 6B are top plan views of prosthetic valve 49 showing material 50 in an open and closed position, respectively. As illustrated in Figure 6A, in the open position leaflet pieces 50A and 50C form against the smooth contour side wall 40 of clip 30. This reduces the stress on material 50 during operation of prosthetic valve 49 over the lifetime of the device.

A prosthetic valve in accordance with the present invention may be made with other types of stents than that shown specifically herein. For example, the stent may be formed of various materials and have any desired flexibility for a particular application. The posts, or commissure supports may be formed as desired having other characteristics, tapering or configurations. The locations and the number of the posts may also be varied. A prosthetic heart valve in accordance with the invention may include a fabric covering or wrap, and/or a sewing ring or cuff. The construction, design and placement of these features are well known in the art. While a stent and the clip in accordance with the invention may be produced of any biocompatible material, e.g., material compatible with blood and/or tissue, practical considerations suggest the use of commercially, medically available materials. For example, these parts may be formed or preformed from any metal, synthetic polymer, biopolymer, etc. which is capable of functioning as required, or may be composite materials. It may also be desirable to sterilize the material by exposure to gas plasma, steam, gamma or electron beam irradiation, or chemical sterilization such as ethylene oxide, formaldehyde, glutaraldehyde, peroxides, and propylene oxide, and preferably any such material is capable of

withstanding such exposure. The invention is not limited to the material used to construct the stent and includes other materials, their mixtures, etc.

Suitable synthetic polymers for use as a stent or clip include, but are not limited to, thermoplastics, such as polyolefins, polyesters, polyamides, polysulfones, acrylics, polyacrylonitriles, and polyaramides. Examples, include, but are not limited to polyetheretherketone (PEEK).

Suitable biopolymers for the stent or clip are biomolecules that have a repeating or polymer-like structure, including but not limited to, natural polymers such as collagen or elastin, or synthetic biopolymers, such as polyaminoacids or synthetic proteins, polysaccharides and mixtures or composites thereof.

Suitable metals for the stent or clip include, but are not limited to, cobalt, titanium, and alloys thereof. For example, an alloy sold under the trademark Eligiloy® is a cobalt-chromium-nickel-molybdenum-iron alloy (ASTM F1058).

Suitable ceramics for use as a stent or clip include, but are not limited to, alumina, zirconia, carbides, nitrides, and cermets. Closely related carbons could also be used. For example, pyrolytic carbon has desirable properties and is widely used in various heart valves.

Preferred materials are synthetic, polymeric materials, and most preferred are materials that can be injection molded. The selected material needs to have both the required stress and strain characteristics as well as good long term mechanical stability. Certain metals, such as Eligiloy®, may be advantageously used, as well as various polymers or biopolymers. PEEK is



known to have mechanical properties in the desirable range, including a tensile strength of 14.5; a flexural modulus of 594.0; and a flexural strength of 24.65 (all in ksi at 73°F). PEEK is also advantageous in that it has a high fatigue endurance limit, a low rate of creep, a low rate of water absorption at equilibrium, and significant radiation resiliency for the purposes of sterilization. At present, the most desirable starting material for use in forming a stent according to the present invention is PEEK.

The biocompatible material for the leaflets preferably includes both biological or synthetic polymers which could be either naturally occurring or artificially produced.

Biological material for use in this invention includes relatively intact tissue as well as decellularized or otherwise modified tissue. These tissues may be obtained from, for example, heart valves, pericardial tissue, dura mater, fascia, skin or any other membranous tissue. Generally, the tissue is composed of collagen-containing structures derived from different animal species such as human, bovine, porcine, equine, seal, or kangaroo, as well as engineered tissues. Engineered tissue typically involves repopulated matrices which can be derived from the tissues mentioned above or synthetically fabricated. The biological tissue may be fixed to cross-link the tissue and provide mechanical stabilization by preventing enzymatic degradation of the tissue, although the matrices do not necessarily need to be fixed. Glutaraldehyde is typically used to fix the material, but other fixation methods, such as epoxides, other difunctional aldehydes, or photooxidation can be used.

Synthetic, biocompatible materials for use in the prosthesis of the present invention include synthetic polymers as well as biological polymers. Synthetic polymers include polyamides (nylon), polyesters, polystyrene, polyacrylates, vinyl polymers (e.g. polyethylene, polytetrafluoroethylene, polypropylene and polyvinylchloride), polycarbonate, polyurethane, polydimethyl siloxane, cellulose acetate, polymethyl methacrylate, ethylene vinyl acetate, polysulfone, and similar copolymers. Biological polymers include natural forms such as collagen, elastin and cellulose or purified biopolymers such as polyaminoacids or polysaccharides. All of these materials can be used singularly or in a combination thereof and can be molded or cast into the selected forms or can be knit or woven into a mesh to form a matrix.

Materials which comprise either the stent, clips or leaflets can remain untreated or can be treated to effect a desired result, for example, to make the part(s) more effective within the environment of the heart. The modification could be in the form of surface finish alterations or in chemical modifications applied to the stent, clip or leaflet material. Surface finish alterations could include adding texture to the inside of the clip and/or the outside of the commissure post to increase the friction force imparted on the leaflet material by the clip, effectively increasing the clamping force. Surface texture could also be added to the external surfaces of the stent, clip or leaflet to optimize cell adhesion and growth. The degree of texturing must be controlled such that cell adhesion is encouraged without introducing the possibility of increased thrombolytic problems. To achieve this end,

-10-

the surface finish of some portions of the stent and clip may require a reduction in roughness. Ideally, the surface finish of different surface locations on the stent and clip may be tuned independently to optimize the characteristics of the entire prosthesis. Other surface finish modifications may be implemented to increase the wetting surface tension, to decrease the harmful effects of some sterilization protocols, or to ease production.

Appropriate chemical modifications to these materials can include any or all of the following. Thrombogenicity of the surface can be modified, for example with heparin. Other modifiers such as fibronectin or other arginine-glycine-aspartic acid (RGD) sequence containing peptides can be used to modify the healing response of the part(s). Additionally, growth factors such as fibroblast or endothelial cell growth factors or other chemotactants can be applied to improve biocompatibility.

Problems associated with calcification can be mitigated by the application of anticalcifics such as multivalent ions and diphosphonates. The part(s) can also be modified to reduce the potential of microbial colonization by treating them with antimicrobial compounds such as silver or gold or with any of a host of commonly available antibiotics.

The present invention is particularly advantageous because it provides a simple and secure technique for coupling a biocompatible material to a stent. Further, the clips set forth herein distribute stresses over a relatively large area of the material to thereby reduce localized stress which can lead to damage to the valve material. The present invention utilizes a permanent clamping force between the clip and the stent

-11-

which is independent of the closing load of the valve. The edges of the clips are preferably rounded to provide a smooth bending radius for the leaflets when they are in the open position, thereby reducing flexural stresses. The radius of the clip can be optimized to reduce leaflet stresses and strains based on the thickness of the leaflet material. For example, calculations for bending indicate that the leaflet strain is equivalent to the leaflet thickness divided by twice the bending radius. The configuration of the stent and clip also allows the open leaflets to wrap around the outside surface of the clip, increasing the valve's orifice size. The increased orifice results in improved hemodynamics. Assembly of the device is quick and simple and the clip is self aligning with the post and material tab. The clip opens slightly to allow the material tab to fit in the segmented region of the clip. Further, the configuration of the clip and the post ensure that the clip is securely fit against and aligned with the post and the tissue tabs aid in alignment of leaflets to ensure coaptation. The clip is easily sutured to the stent. However, other attachment techniques may be used including wire ties, staples, rivets, etc. Alternatively, the clip could be welded or glued to the commissure post following assembly. The design of the present invention minimizes the amount of hand labor required, facilitating the use of automated equipment to increase valve to valve consistency.

WHAT IS CLAIMED IS:

1. A prosthetic heart valve, comprising:  
a stent having an inflow ring and a plurality of posts, each post extending from the ring to a post tip;  
biocompatible leaflet material extending over the stent and substantially conforming to a profile of the stent, the material including a plurality of portions each of which extends adjacent a post tip; and  
a clip having a shape generally conforming around one of the plurality of posts to clamp one of the portions of the material to the one of the plurality of posts.
2. The prosthetic heart valve of claim 1 including a post tip knob located at the post tip to maintain the clip on the one of the plurality of posts.
3. The prosthetic heart valve of claim 1 wherein the clip has an elongated generally 'C' shape.
4. The prosthetic heart valve of claim 1 wherein the clip comprises a polymer.
5. The prosthetic heart valve of claim 1 wherein the stent comprises a polymer.
6. The prosthetic heart valve of claim 1 wherein the clip comprises a metal.
7. The prosthetic heart valve of claim 1 including a means for coupling the clip to the stent proximate the ring.
8. The prosthetic heart valve of claim 1 including a plurality of clips to clamp respective, adjacent portions of material to each of the plurality of posts.

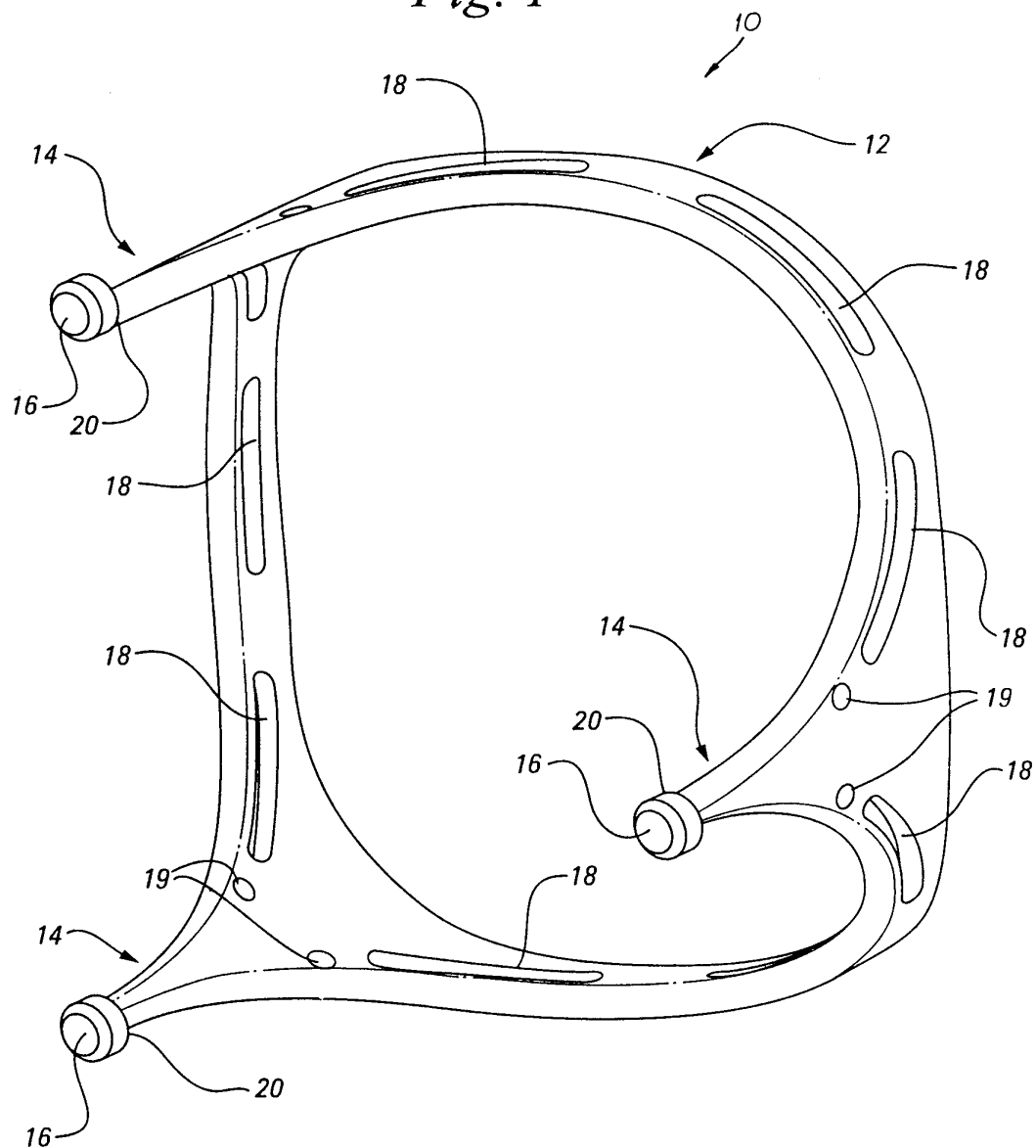
-13-

9. The prosthetic heart valve of claim 1 wherein the clip includes a segmented region formed therein and the material includes a tab which fits in the segmented region to aid alignment and ensure leaflet coaptation.

10. The prosthetic heart valve of claim 1 wherein the material moves between an open position and a closed position and the clip includes a curved side wall, the material pressing against the curved side wall when in the open position.

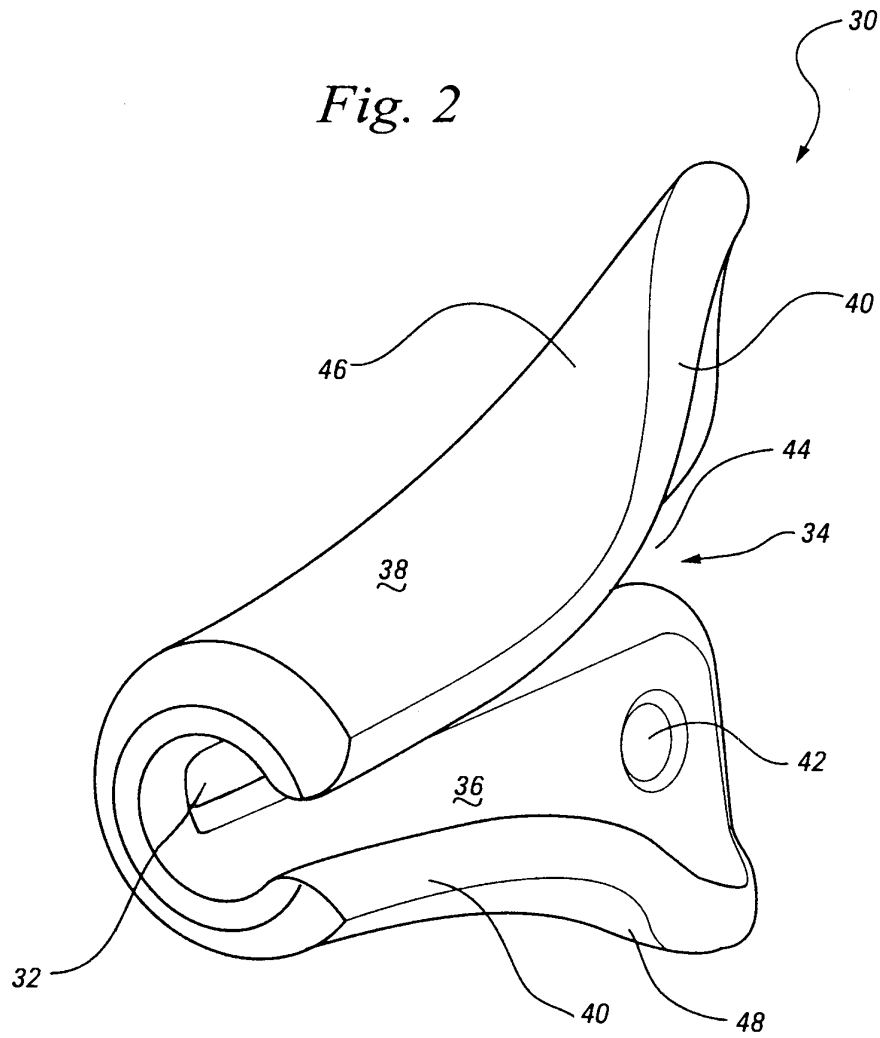
11. The prosthetic heart valve of claim 1 wherein each of the plurality of posts taper in a direction toward the post tip and the clip has a shape generally conforming to the taper.

Fig. 1



**SUBSTITUTE SHEET (RULE 26)**

2/6

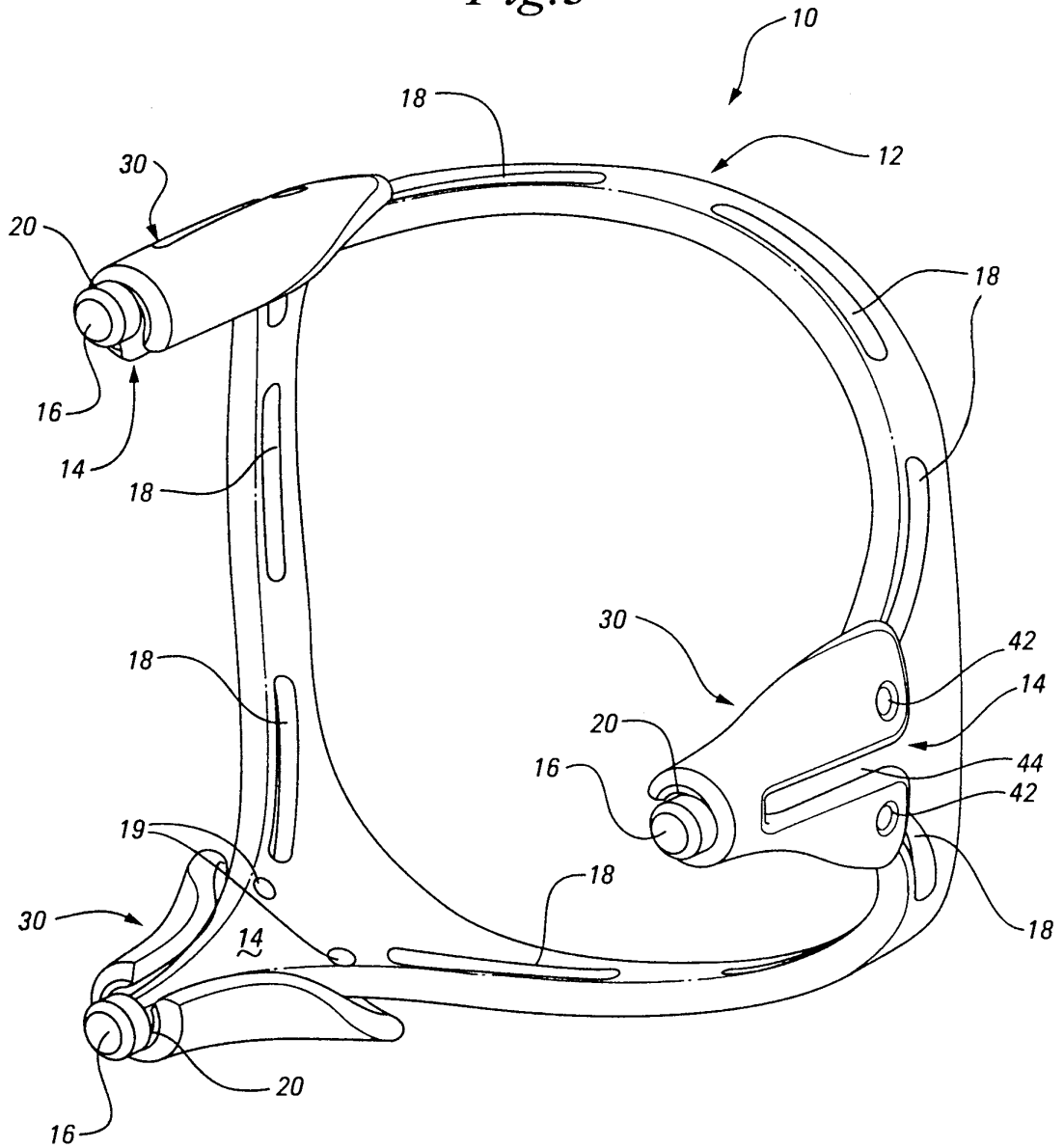


**SUBSTITUTE SHEET (RULE 26)**



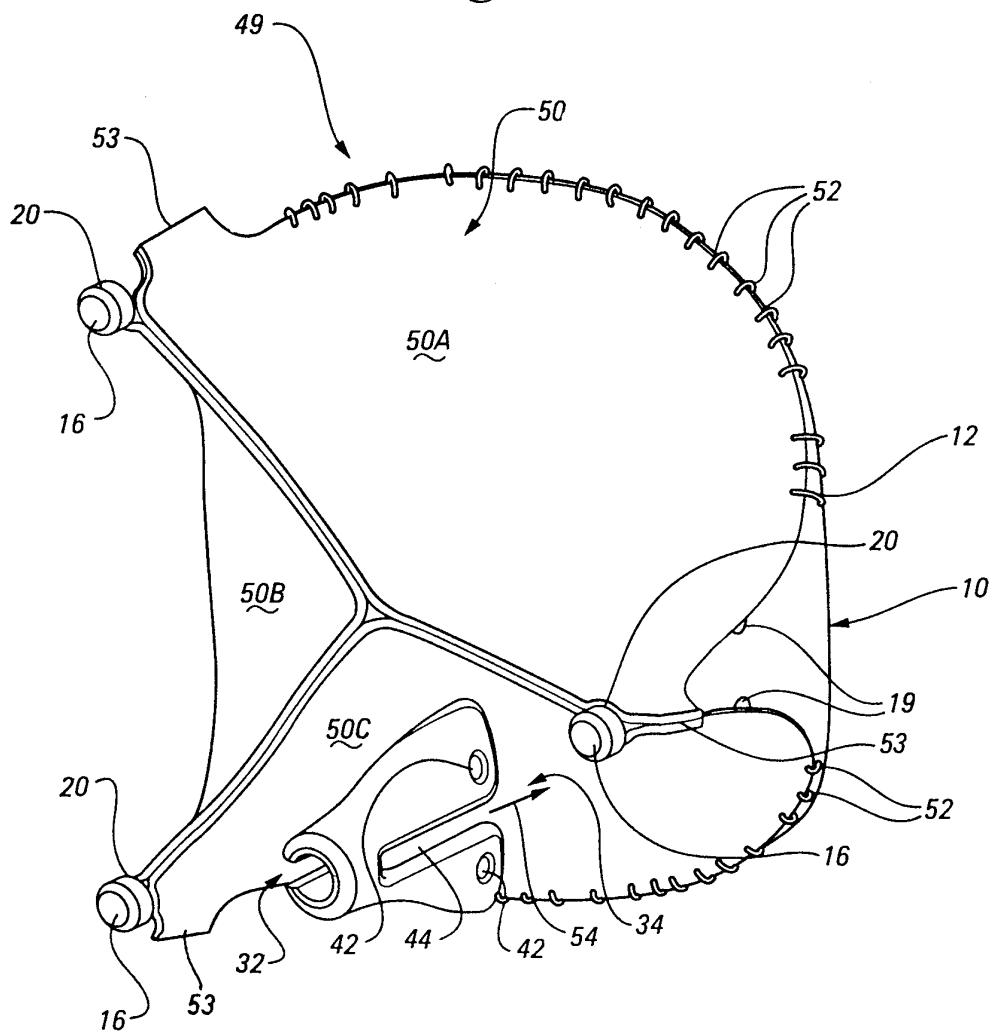
3/6

Fig.3



**SUBSTITUTE SHEET (RULE 26)**

Fig. 4



**SUBSTITUTE SHEET (RULE 26)**

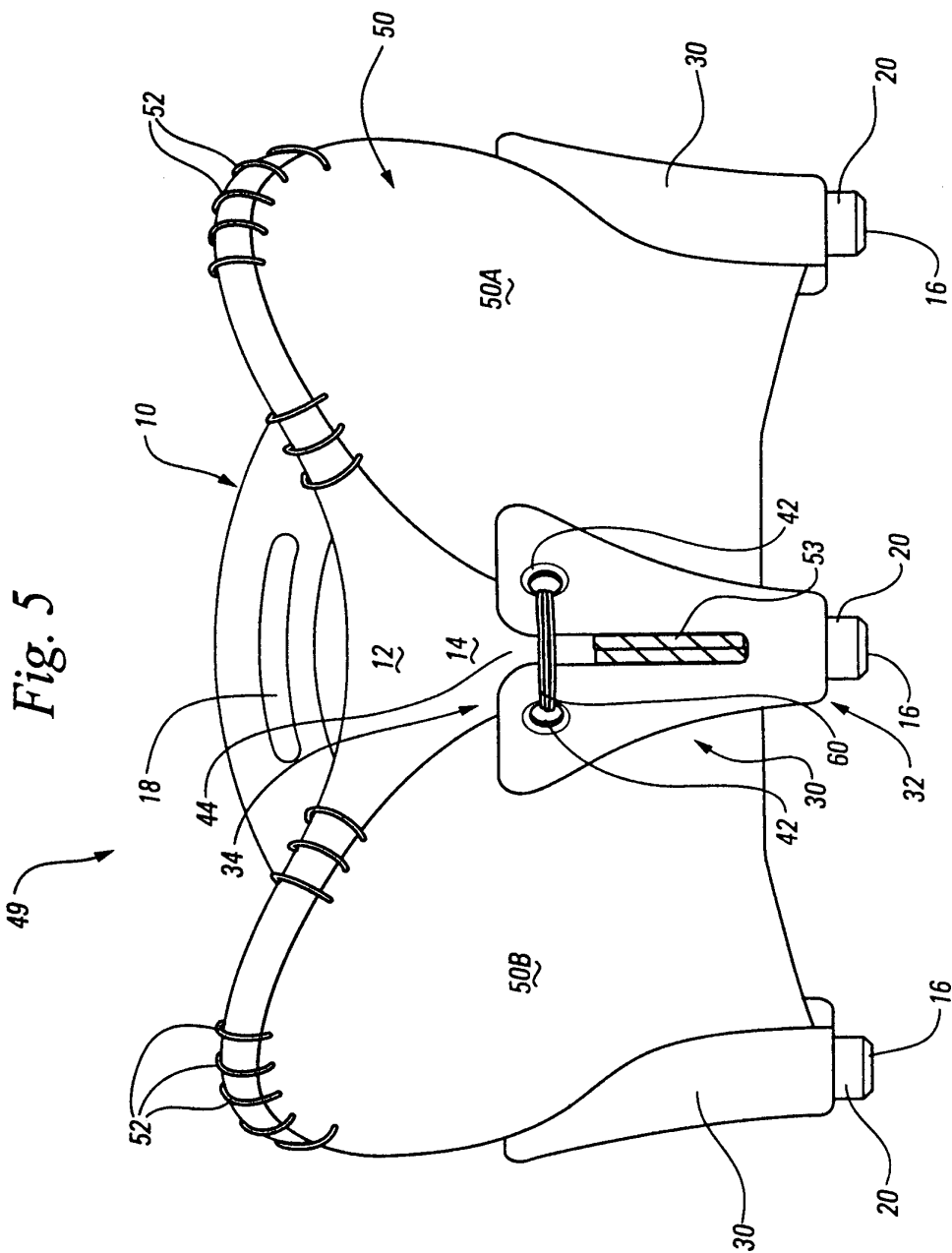


Fig. 5

**SUBSTITUTE SHEET (RULE 26)**

Fig. 6b

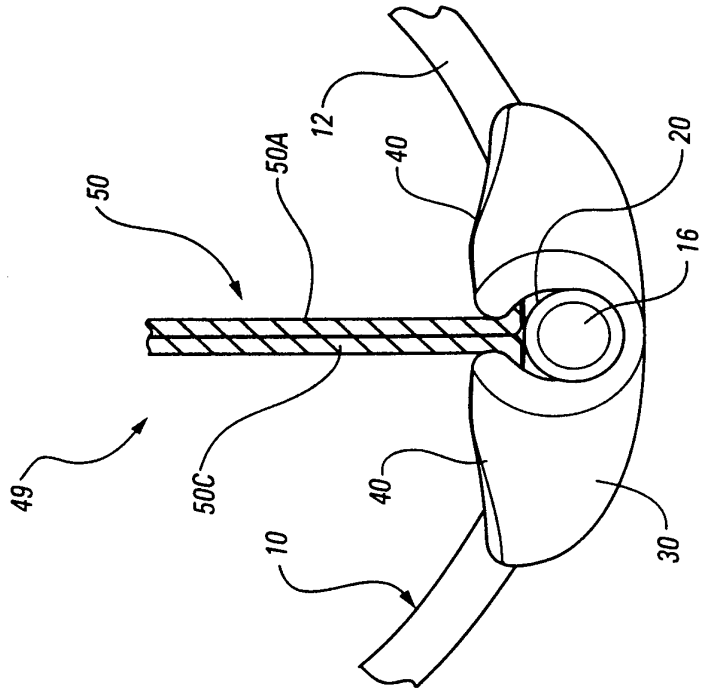
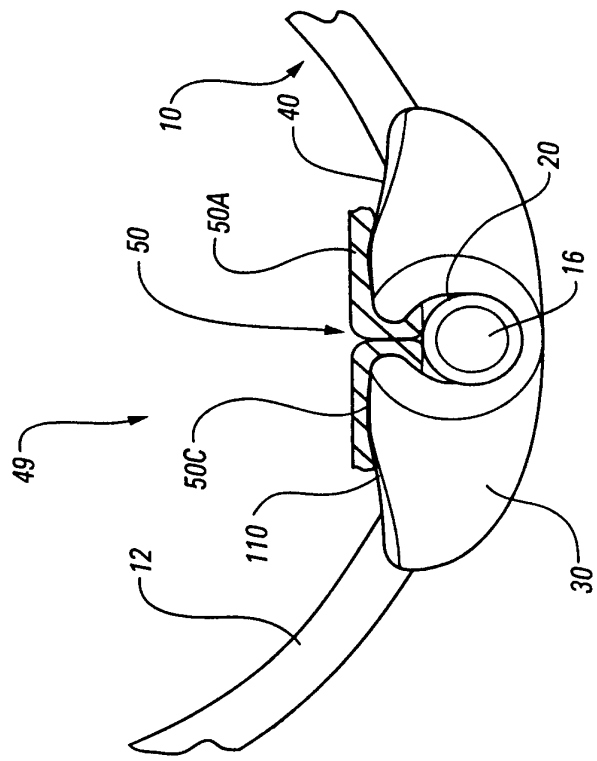


Fig. 6a



**SUBSTITUTE SHEET (RULE 26)**

# INTERNATIONAL SEARCH REPORT

International Application No  
PCT/US 98/26173

<b>A. CLASSIFICATION OF SUBJECT MATTER</b> IPC 6 A61F2/24		
According to International Patent Classification (IPC) or to both national classification and IPC		
<b>B. FIELDS SEARCHED</b> Minimum documentation searched (classification system followed by classification symbols) IPC 6 A61F		
Documentation searched other than minimum documentation to the extent that such documents are included in the fields searched		
Electronic data base consulted during the international search (name of data base and, where practical, search terms used)		
<b>C. DOCUMENTS CONSIDERED TO BE RELEVANT</b>		
Category °	Citation of document, with indication, where appropriate, of the relevant passages	Relevant to claim No.
A	US 4 470 157 A (LOVE JACK W) 11 September 1984 see column 5, line 56 - line 68; claims 17,27; figure 16 ---	1
A	US 5 562 729 A (PURDY DAVID L ET AL) 8 October 1996 see column 4, line 45 - line 57; figures 1,2 ---	1
A	US 4 687 483 A (FISHER JOHN ET AL) 18 August 1987 see column 4, line 10 - line 36; claim 1; figures 1,6 -----	1
<input type="checkbox"/> Further documents are listed in the continuation of box C.		
<input checked="" type="checkbox"/> Patent family members are listed in annex.		
° Special categories of cited documents :		
"A" document defining the general state of the art which is not considered to be of particular relevance "E" earlier document but published on or after the international filing date "L" document which may throw doubts on priority claim(s) or which is cited to establish the publication date of another citation or other special reason (as specified) "O" document referring to an oral disclosure, use, exhibition or other means "P" document published prior to the international filing date but later than the priority date claimed		
"T" later document published after the international filing date or priority date and not in conflict with the application but cited to understand the principle or theory underlying the invention "X" document of particular relevance: the claimed invention cannot be considered novel or cannot be considered to involve an inventive step when the document is taken alone "Y" document of particular relevance: the claimed invention cannot be considered to involve an inventive step when the document is combined with one or more other such documents, such combination being obvious to a person skilled in the art. "&" document member of the same patent family		
Date of the actual completion of the international search  <p style="text-align: center;">31 March 1999</p>	Date of mailing of the international search report  <p style="text-align: center;">08/04/1999</p>	
Name and mailing address of the ISA European Patent Office, P.B. 5818 Patentlaan 2 NL - 2280 HV Rijswijk Tel. (+31-70) 340-2040, Tx. 31 651 epo nl, Fax: (+31-70) 340-3016	Authorized officer  <p style="text-align: center;">Kanal, P</p>	

1

# INTERNATIONAL SEARCH REPORT

Information on patent family members

In International Application No PCT/US 98/26173
--

Patent document cited in search report		Publication date	Patent family member(s)	Publication date
US 4470157	A	11-09-1984	NONE	
US 5562729	A	08-10-1996	NONE	
US 4687483	A	18-08-1987	AT 44451 T	15-07-1989
			CA 1243453 A	25-10-1988
			EP 0179562 A	30-04-1986
			JP 1510682 C	09-08-1989
			JP 61179147 A	11-08-1986
			JP 63059702 B	21-11-1988

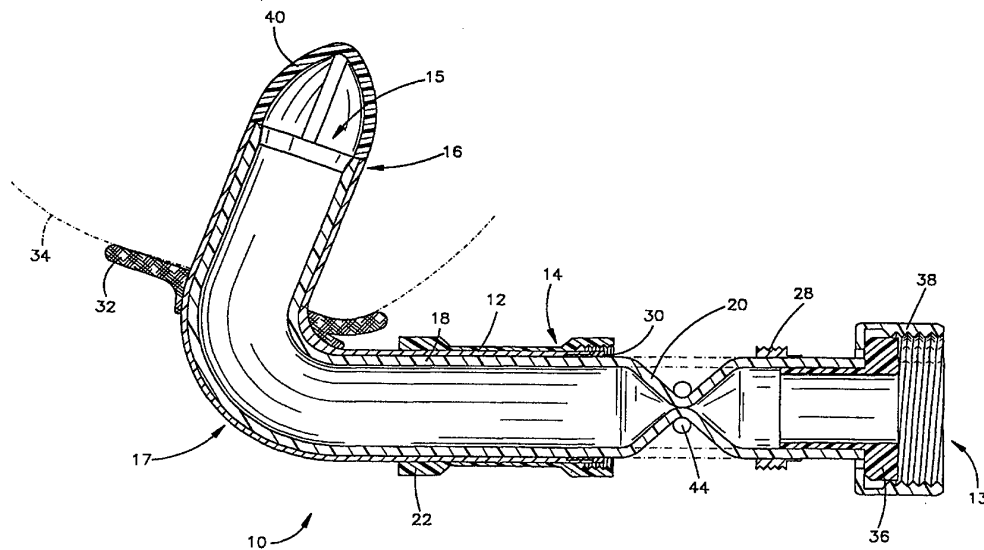
Form PCT/ISA/210 (patent family annex) (July 1992)



INTERNATIONAL APPLICATION PUBLISHED UNDER THE PATENT COOPERATION TREATY (PCT)

<p>(51) International Patent Classification <sup>6</sup> : <b>A61M 25/00</b></p>	<p><b>A1</b></p>	<p>(11) International Publication Number: <b>WO 00/12164</b> (43) International Publication Date: 9 March 2000 (09.03.00)</p>
<p>(21) International Application Number: PCT/US99/19474 (22) International Filing Date: 26 August 1999 (26.08.99) (30) Priority Data: 09/141,225 27 August 1998 (27.08.98) US (71) Applicant (for all designated States except US): THE CLEVELAND CLINIC FOUNDATION [US/US]; 9500 Euclid Avenue, Cleveland, OH 44195 (US). (72) Inventor; and (75) Inventor/Applicant (for US only): CHEN, Ji-Feng [US/US]; 1217 Elbur Avenue, Lakewood, OH 44107 (US). (74) Agents: LONGMUIR, Jeanne, E. et al.; Calfee, Halter &amp; Griswold LLP, 1400 McDonald Investment Center, 800 Superior Avenue, Cleveland, OH 44114-2688 (US).</p>		<p>(81) Designated States: CA, JP, US, European patent (AT, BE, CH, CY, DE, DK, ES, FI, FR, GB, GR, IE, IT, LU, MC, NL, PT, SE).  <b>Published</b> <i>With international search report.</i></p>

(54) Title: RIGID CLAMPABLE CANNULA



(57) Abstract

A clamping cannula (10) comprises a generally rigid layer (12) having a first end (14), and a generally flexible tube (18) generally coaxial with the rigid layer. The flexible tube extends axially in a first direction beyond the first end. The cannula also has a generally rigid sleeve (22) movable between a cover position (Fig. 1), wherein the sleeve covers a first part of the flexible tube, and an uncovered position (Fig. 2), wherein the sleeve does not cover the first part of a flexible tube to enable clamping of the cannula.

**FOR THE PURPOSES OF INFORMATION ONLY**

Codes used to identify States party to the PCT on the front pages of pamphlets publishing international applications under the PCT.

AL	Albania	ES	Spain	LS	Lesotho	SI	Slovenia
AM	Armenia	FI	Finland	LT	Lithuania	SK	Slovakia
AT	Austria	FR	France	LU	Luxembourg	SN	Senegal
AU	Australia	GA	Gabon	LV	Latvia	SZ	Swaziland
AZ	Azerbaijan	GB	United Kingdom	MC	Monaco	TD	Chad
BA	Bosnia and Herzegovina	GE	Georgia	MD	Republic of Moldova	TG	Togo
BB	Barbados	GH	Ghana	MG	Madagascar	TJ	Tajikistan
BE	Belgium	GN	Guinea	MK	The former Yugoslav Republic of Macedonia	TM	Turkmenistan
BF	Burkina Faso	GR	Greece	ML	Mali	TR	Turkey
BG	Bulgaria	HU	Hungary	MN	Mongolia	TT	Trinidad and Tobago
BJ	Benin	IE	Ireland	MR	Mauritania	UA	Ukraine
BR	Brazil	IL	Israel	MW	Malawi	UG	Uganda
BY	Belarus	IS	Iceland	MX	Mexico	US	United States of America
CA	Canada	IT	Italy	NE	Niger	UZ	Uzbekistan
CF	Central African Republic	JP	Japan	NL	Netherlands	VN	Viet Nam
CG	Congo	KE	Kenya	NO	Norway	YU	Yugoslavia
CH	Switzerland	KG	Kyrgyzstan	NZ	New Zealand	ZW	Zimbabwe
CI	Côte d'Ivoire	KP	Democratic People's Republic of Korea	PL	Poland		
CM	Cameroon	KR	Republic of Korea	PT	Portugal		
CN	China	KZ	Kazakstan	RO	Romania		
CU	Cuba	LC	Saint Lucia	RU	Russian Federation		
CZ	Czech Republic	LI	Liechtenstein	SD	Sudan		
DE	Germany	LK	Sri Lanka	SE	Sweden		
DK	Denmark	LR	Liberia	SG	Singapore		
EE	Estonia						





More particularly, the present invention is a clampable cannula comprising a generally rigid section having a first end and a generally flexible section generally coaxial with the rigid section. The flexible section extends axially in a first direction beyond the first end. The cannula also has a generally rigid sleeve moveable between a cover position, wherein the sleeve covers a first part of the flexible section, and an uncovered position, wherein the sleeve does not cover the first part of a flexible section, to enable clamping of the cannula. The sleeve ensures that the cannula remains protected from inadvertent closure.

Another aspect of the present invention provides a method for implanting a cannula and ventricle assist device into the heart of a patient, the method comprising the steps of clamping a flexible section of the cannula; installing an end of a cannula into the heart; connecting the ventricle assist device to the cannula; and unclamping the flexible section.

Other features and advantages of the present device will become apparent from the following detailed description, with reference to the accompanying drawings and claims, which form a part of the specification.

### Brief Description of The Drawings

In the accompanying drawings, which are incorporated in and constitute a part of this specification, numerous embodiments of the device described are illustrated, and together with the general description above, and the description below, exemplify the device of the present application.

Fig. 1 is a side cross-sectional view of the cannula of the present invention shown with the sleeve in the cover position;

Fig. 2 is a side cross-sectional view of the cannula of Fig. 1, shown with the sleeve in the uncover position and being clamped with a clamp, with the unclamped shape of the cannula shown in hidden lines;

Fig. 3 is a side cross-sectional view of an alternate embodiment of the cannula of the present invention shown with the sleeve in the cover position;

Fig. 4 is a side cross-sectional view of the cannula of Fig. 3, shown with the sleeve in the uncover position and being clamped with a clamp;

Fig. 5 is a side cross-sectional view of the sleeve shown in Fig. 3 with the sleeve bent at an angle; and

Fig. 6 is a perspective view of the cannula shown with a ventricle assist device installed thereon.

### Detailed Description of the Invention

Fig. 1 shows the cannula of the present invention, generally designated 10. The  
5 cannula 10 has an inflow end 15 and an outflow end 13. The cannula 10 comprises a  
generally rigid layer 12 having a first end 14 and a second end 16. The cannula 10 further  
comprises a generally flexible tube 18 generally coaxial with the rigid layer 12. In the  
illustrated embodiment the flexible tube 18 extends from the first end 14 of the rigid layer to  
10 the second end 16 of the rigid layer 12, and has an axially extending portion 20 extending  
beyond the first end 14. However, it is not essential that the flexible tube 18 extend back to  
the first end 16, merely as long as the tube 16 includes an axially extending portion 20. The  
flexible tube 18 may be bonded to the rigid layer 12 with a biocompatible, or blood  
compatible, adhesive. A cuff 32 is mounted toward the second end 16 of the rigid layer 12.  
15 The cuff provides a surface for attaching the cannula 10 to the heart wall, shown in phantom  
as 34. In a preferred embodiment, the cuff 32 is a fabric, such as polyester fabric, and the  
cuff may be sewn to the heart wall 34.

The flexible tube is preferably a flexible polymer, such as polyurethane. The flexible  
tube 18 is also preferably coated with a biocompatible urethane, and/or blood compatible  
urethane, on its inner surface (i.e. its blood-contacting surface). The blood compatible  
20 coating may be located on top of the biocompatible coating. In an alternate embodiment, the  
rigid layer 12 is somewhat flexible to be molded and bent to a desired configuration. The  
form shown in Figs. 1 and 2, which includes bend 17, shows merely one of many possible  
configuration of the cannula 10. The rigid layer 12 may be made of any suitable material,  
including titanium, titanium alloys, carbon fiber epoxy, and other materials. The rigid layer  
25 12 is preferably made of a biocompatible material. Furthermore, the rigid layer 12 has a  
blood compatible coating on its blood contacting surfaces. The blood contacting surfaces of  
the rigid layer 12 are those portions within the heart wall 34; that is, forward of the cuff 32.

The cannula 10 further includes a generally rigid sleeve 22 that is coaxial with the  
rigid layer 12. The sleeve 22 is moveable between a cover position, as shown in Fig. 1, to an  
30 uncovered position shown in Fig. 2. The sleeve 22 is retained in the cover position by a  
fixation ring 28 having an external set of threads thereon. The sleeve 22 is preferably made  
from a titanium alloy, as is the fixation ring 28. The sleeve 22 has a set of cooperating  
threads which engage the fixation ring 28 to retain the sleeve 22 in the covered position.  
Nearly any manner of retaining means for retaining the sleeve 22 in the cover position may

be used without departing from the scope of the present invention. A finishing ring 30 may be located adjacent the first end 14 of the rigid layer 12 to provide a finished edge to the outside of the cannula 10.

As shown in figure 6, outlet fitting 36 is disposed in the axially extending end 20 to receive a threaded end of a tube 40 which delivers the blood to the ventricle assist device or blood pump 50. The ventricle assist device 50 may comprise a centrifugal pump or other pump which is known and readily apparent to those skilled in the art. The ventricle assist device further comprises an outlet tube 60 which is connected to the artery of a patient, and an electrical connector 70 for connection to a power source. The outlet fitting 36 (which is an inlet fitting in relation to the ventricle assist device) is preferably made of a titanium alloy. Clamp ring 38 retains the outlet fitting 36 in place, and is threaded to receive a corresponding threaded tube. The fixation ring 28 also clamps down on the outlet fitting 36 to provide a tight seal therebetween. A wire cage 40 is provided at the inflow end 15 of the cannula 10 to ensure the inflow end 15 remains in an open position, i.e., to prevent the ingress of tissue into the cannula due to the suction force of the ventricle assist device.

The clamping of the cannula 10 is as follows. As shown on Fig. 1, the sleeve 22 is in the cover position and covers the axially extending end 20 of the flexible tube 18. In this manner the cannula 10 is protected by the rigid layer 12 and the sleeve 22. Thus the cannula 10 avoids inadvertent closure due to pressure applied by internal organs, and also avoid kinking. When it is desired to clamp the cannula, the sleeve 22 is uncoupled from the fixation ring 28, and slid axially along the rigid layer 12 to the uncover position, as shown in Fig. 2. This leaves the axially extending end 20 of the flexible tube 18 exposed. A clamp 44, as shown in Fig. 2, may then be placed over the axially extending end 20 to block fluid flow through the cannula 10. When it is desired to allow flow to resume through the cannula 10, the clamp 44 is removed, and the tube 18 returns to its original form as shown in Fig. 1. The tube may return to its original shape by either the natural tendency of the tube, or the pressure of the blood in the cannula. The sleeve 22 may then be returned to the cover position and attached to the fixation ring 28. Various means may be used for moving the sleeve between the covered and uncovered position. For example, the sleeve 22 may be a split sleeve, thereby allowing it to be completely removed from the cannula 10.

It is to be further understood that several variations may be made without departing from the scope of the invention. For example, the sleeve 22 need not cover the entire axially extending end 20 of the flexible tube, but preferably covers substantially all of the end 20 when in the closed position to provide protection to the end 20 from kinking or closure.

Furthermore, when in the uncovered position, the sleeve 22 may still cover a portion of the axially extending end 20. It is only required that enough of the axially extending end 20 be uncovered so as to allow the clamp 44 to be placed thereon. Furthermore, in an alternate embodiment the flexible tube 18 does not extend to the second end 16 of the rigid layer 12, and extends only to the first end 14.

Additionally, the radial orientation of the rigid layer 12 and the flexible tube 18 may be reversed such that the flexible tube 18 is radially outward of the rigid layer 12. However, care must be taken to ensure that the inner surface of the cannula 10 remains as blood compatible as possible. It is also within the scope of the present invention to have a cannula having a generally rigid section and a generally flexible section. In this case, the rigid section and flexible section are not necessarily different layers, but may be different materials, or the same material having a different stiffness or rigidity. For example, the rigid section may be made from generally the same material as the flexible section, but the rigid section of the cannula may be treated so as to have increased stiffness, or may have chemicals added to it to make it stiffer. Alternately, the flexible section may instead be treated in order to make it more flexible, or both sections may be treated. In another embodiment, the flexible section may consist of a flexible material, and the rigid section may be made of the same material, but have a wire mesh, wire strands, or other stiffeners incorporated in the material to add stiffness to the rigid section.

As a further variation, the clampable portion of the cannula 10 may be located in the middle of the cannula. In this embodiment the cannula 10 may have a rigid layer 12 having a discontinuity or area of weakness formed therein, and the flexible tube 18 spans the discontinuity or area of weakness. The flexible tube 18 may or may not extend the entire length of the cannula. The rigid layer 12 may thus have a first portion and a second portion separated by the discontinuity. In this embodiment the sleeve 22 is moveable from a covered position, wherein it covers the exposed flexible tube 18, to an uncovered position, where the flexible tube 18 is exposed and enabled to be clamped.

An alternate embodiment of the sleeve 22 of the present invention is shown in Figs. 3-5 as sleeve 22'. In this embodiment, the sleeve 22' has a telescopic shape and is comprised of two or more portions, for example portions 22'a, 22'b and 22'c are illustrated in the figures. The portions 22a,22b,22c are sized and configured such that they telescopically engage with a mating section. The telescopic shape allows the sleeve to be used with cannulas that have limited axial lengths. The telescoping shape allows the sleeve to move axially such that the three portions 22'a, 22'b, and 22'c radially overlap to expose part of the

flexible tube 18 for clamping (Fig. 4). Each telescopic portion preferably has an inner diameter sized to closely receive the flexible portion when in the closed position to eliminate gaps between the sleeve and the flexible tube 18. It is also desired to have relatively thick walls in the clampable portion of the cannula to increase the elasticity of the clampable portion. This is done to ensure that the clampable portion returns to its fully open shape when the clamp is removed, and also to ensure it remains in its fully open position when blood is flowing therethrough. In particular, it is desirable to avoid closure of the cannula due to pressure of adjacent internal organs, kinking, and closure due to differential pressure between the inside of the cannula and the surrounding environment. As shown in Fig. 5, the sleeve 22' has some flexibility to bend at an angle A to enable molding of the cannula in desired position. The flexible tube is shown in Figs 3 and 4 as including a plurality of grooves on its inner surface to increase the flexibility of the flexible tube 18.

The operation and installation of the cannula 10 may now be described as follows. Prior to installation of the cannula in a patient during open heart surgery, the sleeve 22 of the cannula 10 is moved from its covered position to the uncovered position in order to expose the flexible tube 18. A clamp 44 or other equivalent device is then used to clamp or close off the tube to prevent fluid flow therethrough. The second end 16 of the cannula 10 may now be inserted into the ventricle of the patient's heart and the cuff 32 sewn to the adjacent heart tissue. It is important to note that use of the heart lung machine and heart immobilizing procedure is no longer needed due to the unique clamping feature of the invention, which prevents blood from flowing out of the first end of the cannula 10. Prior art cannulas do not provide for this unique clamping feature, so that a heart lung machine is necessary. The surgeon may then verify whether any blood leakage has occurred around the vicinity of the cuff 32 prior to installing the ventricle assist device.

Next, one end of an outflow cannula 60 is sutured to the artery of the patient, and then the other end is connected to the ventricle assist device. Once the ventricle assist device has been properly connected to the cannula and heart of the patient, the surgeon can release the clamp to ensure the device is operating properly and that no blood leakage has occurred. Once the clamp is removed, the sleeve 22 of the cannula 10 may be moved and secured into the closed position. Should the device need future maintenance, it is important to note that the clamping feature may be again utilized in order to replace the ventricle assist device without the need for the heart lung machine and the drug therapy.

The preferred form of the cannula has been described above. However, with the present disclosure in mind it is believed that obvious alterations to the preferred

embodiments, to achieve comparable features and advantages, will become apparent to those of ordinary skill in the art.

What is claimed is:

1. A clampable cannula comprising:
  - a generally rigid layer having a first end;
  - a generally flexible tube generally coaxial with said rigid layer, said flexible  
5 tube extending axially in a first direction beyond said first end; and
  - a generally rigid sleeve movable between a cover position wherein said sleeve covers a first part of said flexible tube and an uncovered position wherein said sleeve does not cover said first part of said flexible tube to enable clamping of said cannula.
- 10 2. The cannula of claim 1 wherein said flexible tube is located radially inwardly of said rigid layer.
3. The cannula of claim 2 wherein said flexible tube extends in a second direction from said first end, thereby extending inside said rigid layer.
- 15 4. The cannula of claim 3 wherein said flexible tube extends substantially the entire length of said cannula.
5. The cannula of claim 1 wherein said flexible tube is coupled to said rigid layer.
- 20 6. The cannula of claim 1 wherein said sleeve is axially slidable along said rigid layer.
7. The cannula of claim 1 further comprising retainer means for securing said sleeve  
25 in said cover position.
8. The cannula of claim 7 wherein said retainer means includes cooperating threads on said sleeve and on said flexible tube.
- 30 9. The cannula of claim 8 wherein said retainer means further includes a threaded fixation ring coaxially mounted on said flexible tube, said fixation ring being located so as to receive said threads on said sleeve when said sleeve is in said cover position.
10. The cannula of claim 1 wherein said sleeve is made from a titanium alloy.



11. The cannula of claim 1 wherein said rigid layer is moldable.
12. The cannula of claim 1 wherein said flexible tube is polyurethane.
- 5 13. The cannula of claim 12 wherein said flexible tube has a biocompatible surface.
14. The cannula of claim 12 wherein said flexible tube has a blood compatible inner surface.
- 10 15. The cannula of claim 1 wherein said rigid layer is a titanium alloy.
16. The cannula of claim 1 further comprising a sealing ring on said first end of said rigid layer.
- 15 17. The cannula of claim 16 wherein said sealing ring is made from a titanium alloy.
18. The cannula of claim 1 wherein said cannula has an inlet and outlet and wherein said cannula further includes an outlet fitting on said outlet.
- 20 19. The cannula of claim 18 further comprising a wire cage coupled to said inlet.
20. The cannula of claim 1 further comprising a flexible cuff adjacent said rigid layer for attaching said cannula to soft tissue.
- 25 21. The cannula of claim 20 wherein said sleeve is formed of two or more portions which telescopically engage each other.
22. The cannula of claim 1 wherein said rigid layer has a blood compatible coating on its outer surface.
- 30 23. A clampable cannula comprising:  
a generally rigid outer layer;

a generally flexible tube generally coaxial with said rigid layer and radially inward of said outer layer, said flexible tube having an underlay portion overlapping with said rigid layer and an exposed portion extending axially beyond said rigid layer; and

5 a generally rigid sleeve comprised of two or more portions which telescopically engage with each other and cooperate such that the sleeve is movable between a cover position wherein said sleeve generally covers said exposed portion and an uncovered position wherein said sleeve generally does not cover said exposed portion.

24. A clampable cannula comprising:

10 a generally rigid section having a discontinuity; and

a generally flexible section spanning said discontinuity such that said cannula may be clamped at said generally flexible section.

25. The cannula of claim 24 further comprising a generally rigid sleeve movable  
15 from a cover position wherein said sleeve generally covers said flexible section to an uncover position wherein said sleeve generally does not cover said flexible section.

26. The cannula of claim 24 further comprising a sleeve movable from a cover  
20 position wherein said flexible section is protected from closure to an uncover position wherein said flexible section is able to be clamped.

27. The cannula of claim 25 wherein said sleeve is axially slidable along said rigid section.

25 28. The cannula of claim 25 further comprising means for retaining said sleeve in said cover position.

29. The cannula of claim 28 wherein said retaining means includes cooperating  
30 threads on said sleeve and on said rigid section.

30. A method for implanting a cannula and ventricle assist device to the heart of a patient, the method comprising the steps of :

moving a sleeve of the cannula into an uncovered position so that a flexible section of said cannula is exposed;

clamping the flexible section;  
installing an end of a cannula into the heart;  
connecting the ventricle assist device to the cannula; and  
unclamping the flexible section.

5

31. A method for implanting a cannula and ventricle assist device to the heart of a patient, the method comprising the steps of :

clamping a flexible section of the cannula;  
installing an end of a cannula into the heart;  
10 connecting the ventricle assist device to the cannula; and  
unclamping the flexible section.

32. The method of claim 31 further comprising the steps of moving the sleeve of the cannula into a covered position so that the flexible section of said cannula is covered.

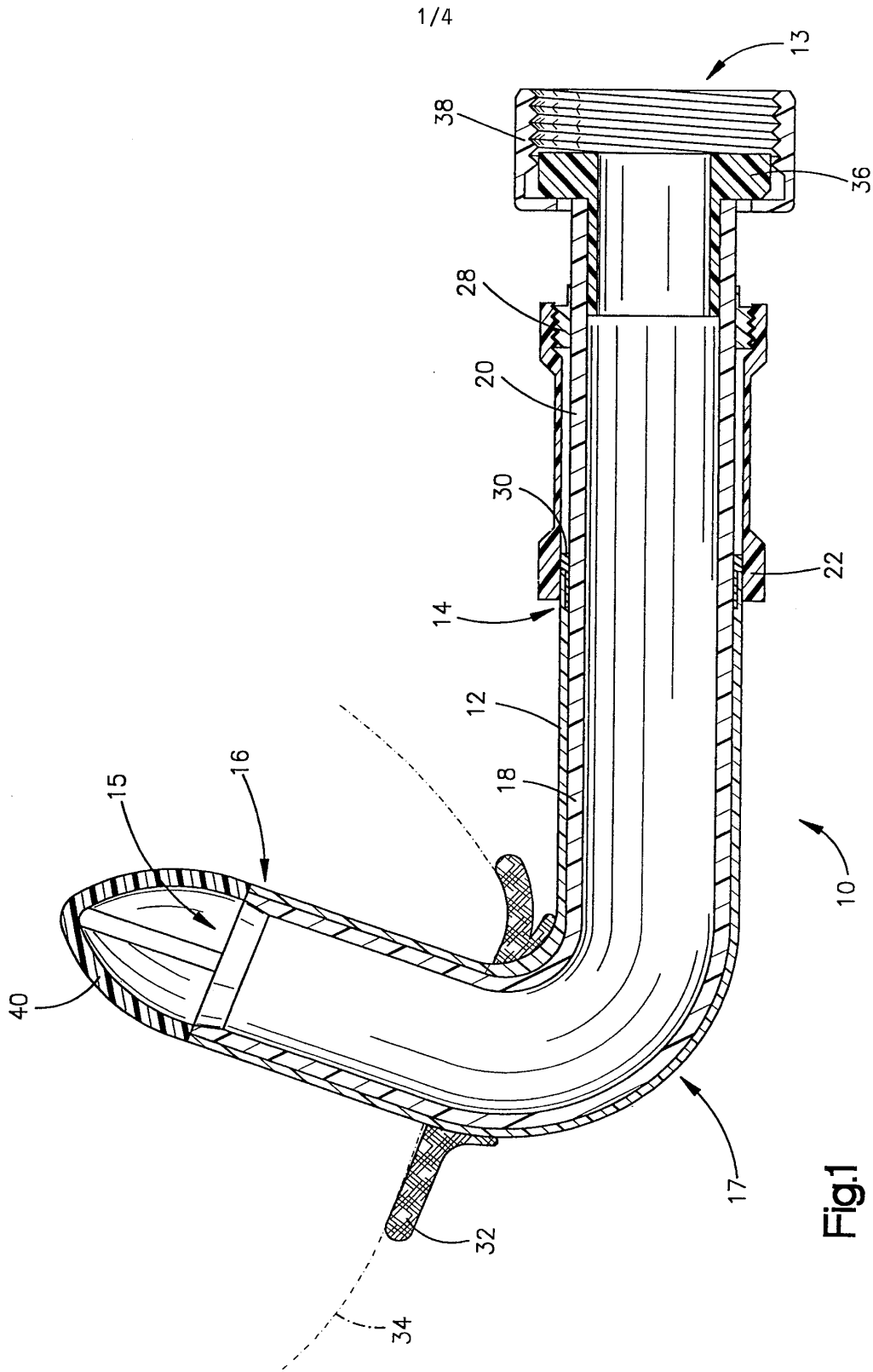
15

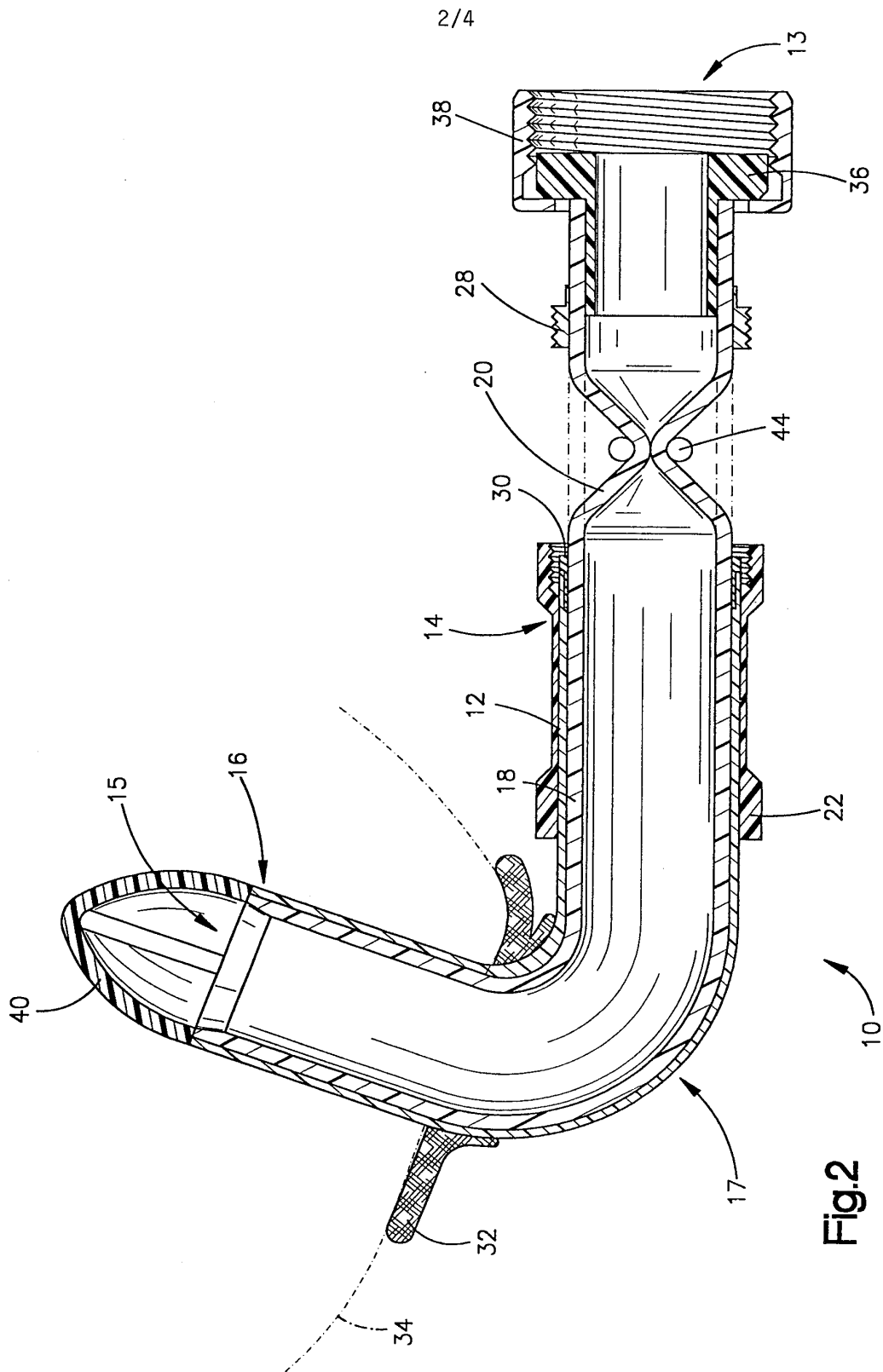
33. A ventricle assist device comprising:

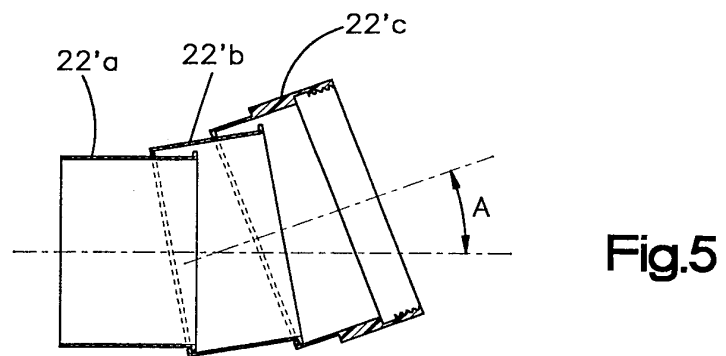
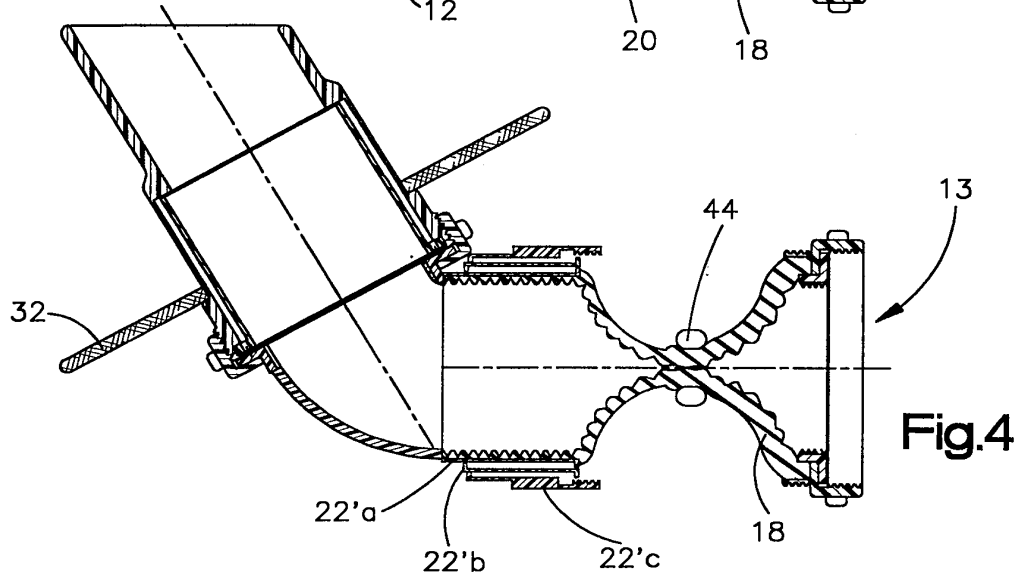
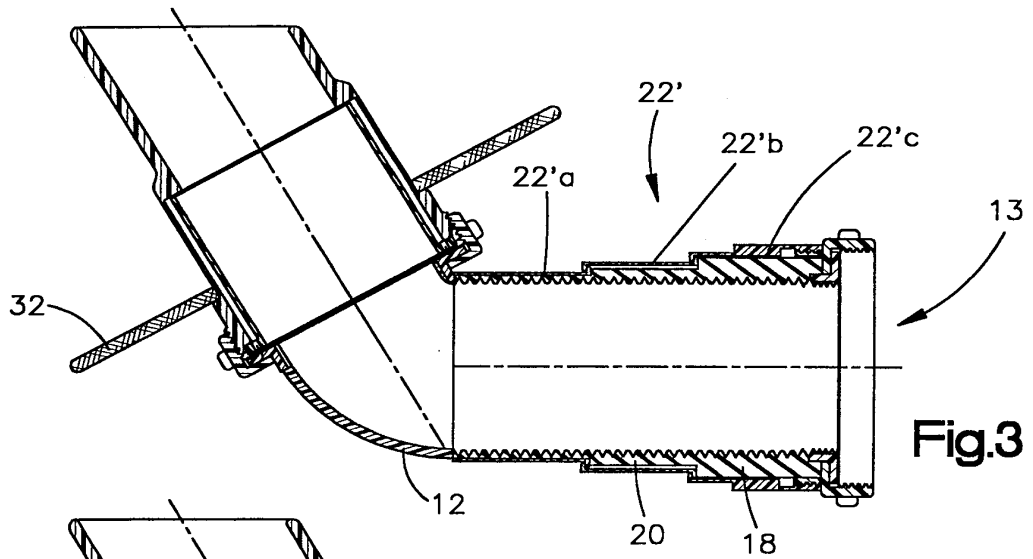
a cannula having a generally rigid outer layer; a generally flexible tube generally coaxial with said rigid layer and radially inward of said outer layer, said flexible tube having an underlay portion overlapping with said rigid layer and an exposed portion extending  
20 axially beyond said rigid layer;

a blood pump and means for supplying power to said pump.

34. The device of claim 33 wherein said cannula further comprises a generally rigid sleeve movable between a cover position wherein said sleeve generally covers said exposed  
25 portion and an uncovered position wherein said sleeve generally does not cover said exposed portion.







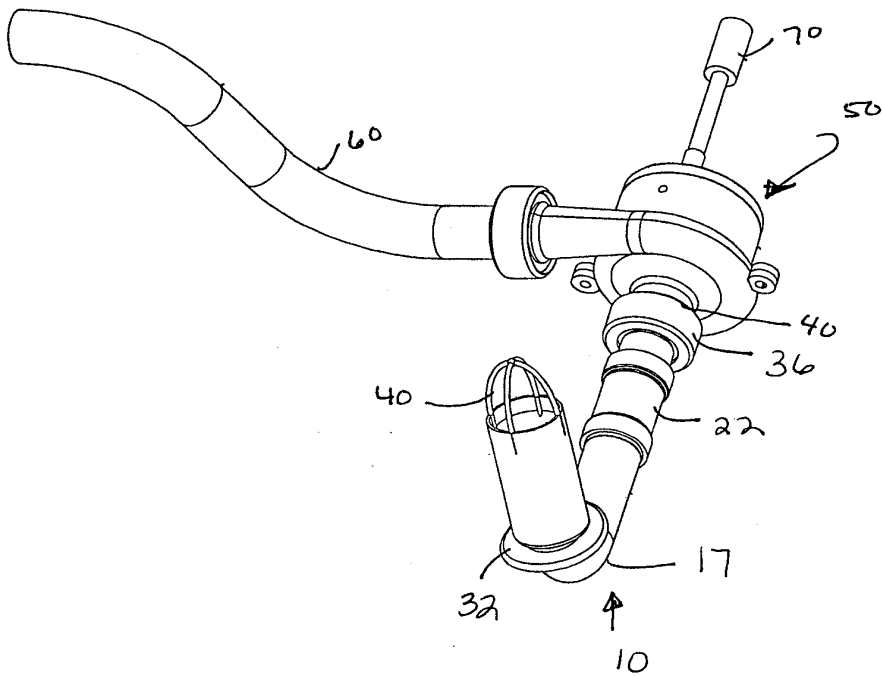
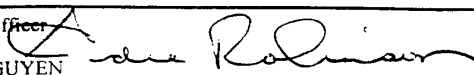


Figure 6

**INTERNATIONAL SEARCH REPORT**

International application No.  
PCT/US99/19474

<b>A. CLASSIFICATION OF SUBJECT MATTER</b> IPC(6) :A61M 25/00 US CL :604/523 According to International Patent Classification (IPC) or to both national classification and IPC		
<b>B. FIELDS SEARCHED</b> Minimum documentation searched (classification system followed by classification symbols) U.S. : 604/93, 167, 171, 174, 179, 256, 523-525, 533, 534 Documentation searched other than minimum documentation to the extent that such documents are included in the fields searched Electronic data base consulted during the international search (name of data base and, where practicable, search terms used)		
<b>C. DOCUMENTS CONSIDERED TO BE RELEVANT</b>		
Category*	Citation of document, with indication, where appropriate, of the relevant passages	Relevant to claim No.
X	US 5,391,171 A (WILLIAMS et al.) 21 February 1995, entire reference.	1-7, 16, 18, 20, 23, 30-33
Y	US 5,445,646 A (EUTENEUER et al.) 29 August 1995, entire reference (especially Fig. 11)	24-28
Y	US 5,695,469 A (SEGAL) 09 December 1997, entire reference.	8, 9, 29
Y	US 4,003,382 A (DYKE) 18 January 1977, col. 1 lines 46-47; col. 2 line 5; and col. 3 lines 16 and 17.	11-14, 21, 22
Y	US 5,653,684 A (LAPTEWICZ et al.) 05 August 1997, entire reference, especially col. 6 lines 38-42; and col. 11 lines 32-34.	10, 15, 19
<input type="checkbox"/> Further documents are listed in the continuation of Box C. <input type="checkbox"/> See patent family annex.		
* Special categories of cited documents: "A" document defining the general state of the art which is not considered to be of particular relevance "E" earlier document published on or after the international filing date "L" document which may throw doubts on priority claim(s) or which is cited to establish the publication date of another citation or other special reason (as specified) "O" document referring to an oral disclosure, use, exhibition or other means "P" document published prior to the international filing date but later than the priority date claimed "T" later document published after the international filing date or priority date and not in conflict with the application but cited to understand the principle or theory underlying the invention "X" document of particular relevance; the claimed invention cannot be considered novel or cannot be considered to involve an inventive step when the document is taken alone "Y" document of particular relevance; the claimed invention cannot be considered to involve an inventive step when the document is combined with one or more other such documents, such combination being obvious to a person skilled in the art "&" document member of the same patent family		
Date of the actual completion of the international search 10 NOVEMBER 1999		Date of mailing of the international search report 08 DEC 1999
Name and mailing address of the ISA/US Commissioner of Patents and Trademarks Box PCT Washington, D.C. 20231 Facsimile No. (703) 305-3230		Authorized officer  A. T. NGUYEN Telephone No. (703) 308-2154



(12) INTERNATIONAL APPLICATION PUBLISHED UNDER THE PATENT COOPERATION TREATY (PCT)

(19) World Intellectual Property Organization  
International Bureau



(43) International Publication Date  
11 January 2001 (11.01.2001)

PCT

(10) International Publication Number  
WO 01/02031 A2

- (51) International Patent Classification<sup>7</sup>: A61L 27/00      **GIRARDOT, Jean-Marie**; 6328 North Peachtree Road, Dunwoody, GA 30338 (US). **GIRARDOT, Marie-Nadia**; 6328 North Peachtree Road, Dunwoody, GA 30338 (US).
- (21) International Application Number: PCT/US00/17606
- (22) International Filing Date: 27 June 2000 (27.06.2000)      (74) Agents: **SAMPLES, Kenneth, H.** et al.; Fitch, Even, Tabin & Flannery, Suite 1600, 120 South LaSalle, Chicago, IL 60603 (US).
- (25) Filing Language: English
- (26) Publication Language: English      (81) Designated States (*national*): AU, CA, JP.
- (30) Priority Data: 60/142,171      1 July 1999 (01.07.1999)      US      (84) Designated States (*regional*): European patent (AT, BE, CH, CY, DE, DK, ES, FI, FR, GB, GR, IE, IT, LU, MC, NL, PT, SE).
- (71) Applicant: **BIOMEDICAL DESIGN, INC.** [US/US]; 2161 New Market Parkway, S.E., Suite 214, Marietta, GA 30067-9310 (US).      **Published:**  
— *Without international search report and to be republished upon receipt of that report.*
- (72) Inventors: **SIMIONESCU, Dan**; 2183-V Lake Park Drive, Smyrna, GA 30080 (US). **SIMIONESCU, Agneta**; 5 Ciucas Street, Apt. 17, R-4300 Targu Mures (RO).      *For two-letter codes and other abbreviations, refer to the "Guidance Notes on Codes and Abbreviations" appearing at the beginning of each regular issue of the PCT Gazette.*



WO 01/02031 A2

(54) Title: TARGETED ANTICALCIFICATION TREATMENT

(57) Abstract: Methods for providing biomaterials with increased resistance to calcification by treating with cell-targeted agents and/or with matrix-targeted agents. Cell-targeted agents are used which block calcium channels or which prevent oxidative damage to cells and/or inhibit enzymes. Other treatments of biomaterials may remove cell-derived calcium-binding components or target extracellular matrices, as by cleaving proteins with cyanogen bromide or reducing disulfide bonds to produce sulfhydryl groups which are thereafter alkylated. Combinations of the foregoing different treatments are also effective in increasing the calcification resistance of cardiovascular tissues that were previously subjected to chemical fixing and/or other anticalcification treatments.

**TARGETED ANTICALCIFICATION TREATMENT**

The present invention relates generally to treating biomaterials destined for implantation in a human patient so as to render such materials resistant to calcification, and more particularly relates to methods for targeting anticalcification treatment to particular biological tissue that has been previously fixed, i.e. chemically cross-linked, so as to render it more resistant to calcification following its implantation in the human patient. Still more particularly, the invention relates to treatments of this type that are targeted to specific biomaterials of a certain character that have heretofore been difficult to effectively render resistant to calcification.

**Background of the Invention**

Degenerative calcification of glutaraldehyde-fixed biological tissues used for bioprosthetic heart valve (BHV) fabrication is presently considered to be a major cause of long-term failure of these implants in a clinical setting. Mitigation of calcification has been investigated (a) by subsequently treating glutaraldehyde-treated tissues with a variety of compounds and (b) by employing fixation procedures which do not employ glutaraldehyde. The results obtained thus far indicate that the type of tissue and its precise composition may be important in determining its susceptibility to calcification. Collagen concentration, for example, varies from about 90% (w/w) in pericardium, to about 40% in aortic cusps, and to only about 25% in aortic wall tissue. On the other hand, elastin accounts for only 1-5% in pericardium and about 10-15% in cusps whereas it may account for up to about 50% of aortic wall tissue. Furthermore, cell types and numbers differ significantly between these three tissues.

Anticalcification treatment of glutaraldehyde fixed tissues such as that disclosed in U.S. Patent No.

4,976,733 and the treatment of tissues not cross-linked by glutaraldehyde in Nos. 5,447,536 and 5,733,339 were shown to be quite effective in reducing calcification of collagenous tissues, such as pericardium and porcine aortic leaflets; however, elastin-containing aortic wall tissue has proven to be less susceptible to reduction of calcification by the above-mentioned treatments. As a result, the investigation has continued for other anticalcification treatments that would specifically target tissue relatively low in collagen, for example tissue having relatively greater amounts of elastin.

Although, the molecular mechanisms of BHV calcification are not well understood, additional elements, e.g. the presence of injured or devitalized cells, are now considered to be important along with the character of cross-linked extracellular matrix. For example, cell injury induced by fixation protocols can lead to impairment of normal calcium homeostasis, followed by a massive calcium influx, and such can, in turn, lead to cell death and calcification of cell remnants. Cross-linked extracellular matrix, on the other hand, can induce calcium deposition per se or, as a consequence of cell-mediated propagation, can induce calcification into the surrounding matrix. Therefore, the molecular substrates that can promote deposition of calcium salts in BHV and other implanted organs may generally be divided into two categories: (a.) cell-derived elements, such as lipid membranes which may contain calcium-transporting channels and calcium ATPases, integrins, cadherins, selectins and annexins, as well as cytoskeletal protein structures present in the close vicinity of devitalized cells, cell enzymes, calmodulin, mitochondria, the cell nucleus and other calcium-binding components, and (b.) extracellular matrix calcium-binding components, such as elastin-associated microfibrillar proteins (EAMF), collagens, proteoglycans, proteolytic enzymes, such as metalloproteinases (MMPs), matrix phosphatases, and other non-collagenous proteins.

A common element that appears to characterize these calcifiable substrates is the ubiquitous presence of one or more high affinity calcium-binding sites or calcium-trapping pockets which, by means of carboxyl and/or hydroxyl groups, attract and immobilize calcium ions. The three-dimensional conformation of these sites is stabilized in the "correct" shape by intramolecular bridges, such as disulfide bonds, and hydrophobic interactions. [See *Guidebook to the Calcium-binding Proteins*, Celio et al., eds., Oxford University Press, Oxford, UK, p. 15-21, 1996]

#### Summary of the Invention

Anticalcification methods have now been devised that take into consideration the character of these molecular substrates that account for calcium deposition in tissues. These new methods accordingly target or challenge such substrates with specific compounds in such a way as to reduce or inhibit overall tissue calcification, without compromising any previously obtained cross-linking or calcification resistance that may have been obtained as a result of treatment with other reagents.

These methods of treatment generally fall into two main classes: cell-targeted treatments and matrix-targeted treatments. The cell-targeted class of treatment includes three general categories; however, in some instances treatments from different classes or from different categories within one class may be used in combination and, as such, may produce an effect that is greater than the effect produced by either class or category of treatment alone. Generally, it has been found that progression from reversible, physiological calcium-binding towards the irreversible deposition of calcium salts into or onto these substrates can be effectively stopped by treatments that destabilize, modify and/or destroy the original conformation of high affinity calcium-binding sites and/or by treatments that

permanently block the access and influx of counterions into otherwise unaltered sites.

In the class of treatment that targets cells, injured cells are protected from degeneration and calcium overload by treating tissue containing such cells to reduce calcium influx into the cells or prevent oxidative and/or enzymatic damage. One may use a calcium channel blocking agent, such as nifedipine (NIF) or diltiazem hydrochloride (DIL), an antioxidant, or an agent, such as captopril (CAP), that inhibits damaging enzymes. Potential cell-related calcification substrates, such as the cytoskeletal proteins actin, myosin, troponin and actinin, can also be removed, extracted or inactivated by using an appropriate extractant, such as a high potassium salt/MgATP mixture (KMA).

In the other class of treatment which targets the extracellular matrix, the structure of calcium-binding components, such as EAMF and MMPs and the like, in extracellular matrices can be appropriately modified to reduce the capacity thereof either to calcify per se or to induce calcification in adjacent components. For example, treatment with a suitable cleaving agent, such as cyanogen bromide (CB), will effect partial cleavage of proteins at methionine residues, whereas protein disulfide bonds can be effectively broken by treatment with a suitable reducing agent, such as dithiothreitol (DTT), and then alkylated with a suitable reactant, such as N-ethylmaleimide (NEM).

#### Detailed Description of the Preferred Embodiments

As mentioned above, it was known that certain tissues, such as the wall of aortic root tissue, have not heretofore been rendered as successfully resistant to calcification as a result of present anticalcification treatments or non-glutaraldehyde cross-linking, as have, for example, tissues containing significantly higher amounts of collagen. However, as indicated, it has now been found that these and other such tissues can be treated by specific cell-targeted and matrix-targeted

anticalcification treatments that are indeed effective. It has been found that the irreversible deposition of calcium salts into or onto these substrates can be effectively stopped by the use of different treatments  
5 within these two classes, which may be used individually or in combination with one another. One category of treatment permanently blocks the access and influx of counterions into such sites in cells. A second category of treatment provides antioxidants which prevent  
10 oxidative damage and inhibit the action of enzymes that promote calcification of cells. A third category extracts cell-related potential calcification sites. Another category of treatment destabilizes, modifies and/or destroys the original conformation of such high  
15 affinity calcium-binding sites and is principally effective against calcification in matrices.

Tissues and biomaterials generally that can benefit from this technology may be characterized as being constituents of either biologic or synthetic origin  
20 which, once implanted in a human, are expected to directly or indirectly suffer the effects of calcification while implanted in a patient. Because these biomaterials are expected to be susceptible to concomitant calcium overload, oxidative damage and/or  
25 enzymatic hydrolysis, the incorporation of protective agents into these biomaterials provides them with reduced susceptibility towards calcification as well as increased biostability and durability.

Biological tissues, as a result of modified  
30 extracellular matrix components or injured cells or both, will frequently present calcifiable substrates to which attention needs to be given; they may be cardiovascular tissues or non-cardiovascular tissues. Examples of the former group include cardiac valves with or without  
35 associated stents, i.e. aortic, mitral, pulmonary and tricuspid valves, pericardium and blood vessels, such as (a) arterial segments of large, medium or small caliber, e.g. aortic, carotid or coronary, and (b) venous segments

of large, medium or small caliber with or without accompanying venous valves, e.g. saphenous, jugular or cavae. Examples of the non-cardiovascular tissue group include tendons, ligaments, articulations, aponeuroses, 5 cartilages, organ capsules and sheaths, membranes, such as fasciae and dura matter, conduits, such as esophagus, trachea, hepatic ducts and ureter, and cavitory organs from the digestive and urinary tracts. Such implanted tissue may be heterologous, homologous or autologous, 10 i.e. of animal or human origin. Overall, the biomaterials which may be treated prior to implantation may be whole tissues, organs or products thereof which are composed of extracellular matrix components, both with and without cells, and they may be in solid, liquid 15 or gel form, e.g. in the form of sheets, sponges or fibers. They may also be products of tissue engineering or of guided tissue regeneration, wherein scaffolds and scaffolds with cells are used.

The biomaterials which are to be treated by the 20 invention may have been previously chemically processed for removal of selected components, such as antigenic determinants, cell remnants, lipids, sugars and the like. As earlier indicated, such tissues may also have been chemically fixed or cross-linked using glutaraldehyde or 25 other procedures. These tissues may also be further processed by pre- or post-fixation treatments with various anticalcification compounds, e.g. 2-aminooleic acid, phosphonates, detergents, ions and dyes; moreover, these biomaterials may be freeze-dried or dehydrated 30 tissues. They may also be tissues or organs that were preserved by deep-freezing in the presence of cryoprotectants, as well as tissues or organs preserved in antibiotic-containing cold solutions.

In accordance with the first treatment category 35 mentioned above, lipid membranes from injured cells which may contain naturally occurring calcium channels and calcium ATPases, integrins, cadherins, selectins and annexins may be protected from calcium overload and/or

degeneration by treating such tissue with a calcium channel blocking agent and/or an antihypertensive agent that is capable of preventing oxidative damage and inhibiting the action of enzymes which have been reported  
5 to cause calcification. Examples of one group of suitable calcium-channel blocking agents include nifedipine (NIF), i.e., 1,4-Dihydro-2,6-dimethyl-4-(2-nitrophenyl)-3,5-pyridinedicarboxylic acid dimethyl ester, nimodipine, nisoldipine, nitredipine, nicardipine,  
10 nilvadipine, amlodipine, lacidipine, verapamil, diltiazem hydrochloride (DIL), i.e., 1,5-Benzothiazepin-4(5H)one, 3-(acetyloxy)-5-[2-(dimethylamino)ethyl]-2,3-dihydro-2-(4-methoxyphenyl)-monohydrochloride, trifluoperazine, bepridil, cinnarizine, fendiline, flunarizine,  
15 lidoflazine, phenylamine, pryanodine, ruthenium red and veratridine.

Useful in the second category of treatment are agents capable of preventing oxidative damage, which may also have antihypertensive properties; such agents  
20 include captopril (CAP), i.e., 1-(3-Mercapto-2-methyl-1-oxopropyl)-L-proline, quinalapril, enalapril, lisinopril and zofenopril. Other examples include allopurinol, nicotinamide, ebselen, resveratrol, xanthine, diphenyl phenylene diamine, chlorpromazine, manitol, catalase,  
25 peroxidase, desferroxamine, polyphenols, N-acetyl cysteine, ubiquinol, butylated hydroxytoluene, probucol, alpha-tocopherol, trolox, superoxid dismutase, thiourea, taurine, propyl galate, histidine, vitamin C, beta-carotene, beta-mercaptoethanol, reduced glutathion,  
30 reduced glutathion monoisopropyl ester, reducible dyes (phenazine methosulfate, nitroblue tetrazolium chloride, tiazolyl blue, methylene blue, toluidine blue), N-tert butyl phenyl nitron, antioxidant peptides (anserine, carnosine, carcinine), Val-Phe-aldehyde, PMSF, leupeptin  
35 benzamidine, soybean trypsin inhibitor. Some compounds, such as CAP, are both antioxidants and inhibitors of metal-containing enzymes.



Combinations of agents from the foregoing two groups may advantageously be employed.

5       Either as an alternative to, or in addition to, the above treatments, it may be desirable and feasible as a third treatment category, to remove potential cell-related calcification substrates, e.g. cytoskeletal proteins such as actin, myosin, troponin and actinin, as well as cell enzymes, calmodulin, mitochondria, cell nuclei and other calcium-binding or calcium-trapping  
10       components. Such tissue is treated using a compound which functions as a suitable cell extractant, e.g. a high concentration potassium salt/MgATP mixture (KMA), to remove, extract and/or inactivate such substrates that are prone to calcium salt accumulation or inducing same,  
15       and such treatment of walls with KMA showed 52-56% reduction in wall calcification following 8 weeks implantation in the rat subdermal model of calcification. Other suitable cell extractants may also be used. Such extraction treatments may be advantageously used in  
20       combination with treatment by proteolytic enzyme inhibitors, such as PMSF, leupeptin, benzamidine and soybean trypsin inhibitor.

      With respect primarily to sites in extracellular matrices where there also are calcium-binding components,  
25       e.g. fibrillin, other EAMF proteins, collagens, proteoglycans, proteolytic enzymes, such as MMPs, phosphatases, and non-collagenous proteins, such as laminin, fibronectin, thrombospondin, tenascin, osteonectin, osteopontin and matrix Gla-protein, the  
30       other main class of matrix-targeted treatment is used. It has been found that such protein components can be effectively modified in such way as to reduce their capacity to calcify per se or to induce calcification in adjacent or related components. One preferred treatment  
35       is to use an appropriate cleaving agent, such as cyanogen bromide (CB), to cleave such proteins at methionine (Met) residues; alternative cleaving agents are well known in the art and include hydroxylamine, N-bromosuccinimide,

N-chlorosuccinimide, thiocyanobenzoic acid, ortho-iodosobenzoic acid and trifluoroperazine. By use of such a modification regimen, the configuration of methionine-containing proteins is changed, and their ability to thereafter bind calcium salts or to induce or promote such binding is very significantly reduced. It has also been found that effective modification to the same end can be effected by breaking intramolecular bridges within proteins, e.g., by altering hydrophobic interactions and/or breaking disulfide bonds. Such modifications can be effected by reduction with dithiothreitol (DTT) or similar well known reducing agents, such as ammonium sulfite, dithioerythritol, sodium sulfite, tri-n-butylphosphine and beta-mercaptoethanol, and then preventing the reversal of such reduction by reacting with a reagent that will bond with a sulfhydryl group. Examples of suitable blocking reagents include alkylating reactants, such as N-ethylmaleimide (NEM), dithiobis-(2-nitrobenzoic acid), iodoacetamide, iodoacetate, p-hydroxymercuri-benzoate and the methanethiosulfonates. Because there may be more proteins with Met residues than there are proteins with disulfide bonds in such extracellular matrices, treatment with CB or an equivalent cleaving agent may be preferred. However, both these modifications have advantageous effects in reducing calcification resulting from the presence of EAMF proteins, MMPs and the like, and the combination of these two treatments may produce the most desirable effect.

Treatments are carried out using the cell-targeted agents at appropriate concentrations, temperatures, pH and durations as generally known in this art for use of such reagents. CAP or similar agents may be used at a concentration of from 1-200 mM (preferably 25-75 mM), at about 15-40°C, and at about pH 6-8 for about 2-72 hours. NIF, DIL and related calcium channel blocking agents would be used at concentrations of about 0.1-50 mM (preferably about 5-25 mM) under otherwise similar

conditions. Cell extractants are used at a similar pH and for a similar duration at temperatures in the range of about 0-20°C. KMA may be used at a KCl concentration between about 0.4 M and about 1.5 M and usually between  
5 0.5-0.8 M and MgATP at concentrations between 0.01-10 mM and usually between about 0.05-8 mM. Although any sequence of treatments with agents from the three categories of cell-targeted agents may generally be used, when such a combination of treatments are employed, the  
10 following sequences are most often used: Category 1 followed by Category 2; Category 2 followed by Category 1; Category 3 followed by Category 2; Category 3 followed by Category 1; and Category 3 followed by Category 1 and Category 2.

15 A cleaving agent, such as CB, is used at a concentration of about 1-200 mM (preferably about 10-50 mM), at a similar pH and temperature as for CAP, but for a shorter duration of about 1-24 hours, e.g., about 3 hours. A reducing agent, such as DTT, might be employed  
20 at a concentration of about 1-200 mM (preferably about 25-75 mM) and at other conditions as for CAP, and treatment with such an agent is preferably followed by treatment with a blocking agent, such as NEM, at a  
25 pH as for CAP, but for a duration of about 12-48 hours, e.g., 24 hours. When combinations of the two classes of treatment are employed, it is preferred that the matrix-targeted class of treatment precede the cell-targeted treatment. For example, treatment with CB, or treatment  
30 with DTT preferably followed by reaction with an alkylating agent, would usually be carried out prior to treatment with a Category 2 agent, with optional treatment thereafter with a Category 1 agent.

The aforementioned treatments are usually carried  
35 out in a buffered aqueous solution, e.g. using a borate buffer or HEPES, PIPES, MOPSO or the like. Washing is carried out following the anticalcification treatment and prior to sterilization. Normal saline or a buffered

aqueous solution, as described above, may be used at about 0-40°C for 15 minutes to 4 hours, with the optional inclusion of up to about 25% isopropanol or another lower alkanol. When a combination of treatment steps is used, washing or rinsing between steps is desirable but not always necessary so long as there is washing prior to sterilization.

The anticalcification treatment may be applied to tissue that is not cross-linked, such as cryopreserved homografts, or to tissue that is cross-linked. When the treatment is applied to cross-linked tissues, it is generally performed after fixation treatment of the biological tissue, although it may be performed previous thereto, or even both before and after. However, when a cell extractant or a reducing agent is used, treatment is preferably carried out prior to fixation. When the present treatment is carried out in combination with another type of anticalcification treatment, such as treating with 2-aminooleic acid as described in the '733 patent, the present treatment is preferably carried out subsequent thereto, except for treatment with a cell extractant or a reducing agent, which is preferably carried out prior to such other type of anticalcification treatment.

It is also important that such targeted methods of anticalcification treatment, when carried out following fixing, do not adversely affect the desirable cross-linking of tissue that has been previously effected, and tests to date show this be true. These treatments also do not appear to have any adverse effect upon the anticalcification properties of the overall tissue, which properties may have been the result of a previously administered anticalcification treatment or non-glutaraldehyde cross-linking, such as described in the aforementioned three U.S. patents that have been proven to provide excellent calcification resistance for porcine valves leaflets.

The foregoing is felt to be important because calcification may concomitantly occur, both in BHV and in other biomaterials, in a variety of different substrates, e.g. in cells and in extracellular matrix. As a result, sequential treatment using several targeted treatment methods that are compatible with one another may very well be important in achieving the overall desired effect. For example, it may be desirable to treat cell-containing BHV tissue to block calcium channels and/or reduce oxidizing and/or enzymatic damage, and/or extract or inactivate certain proteins, such as actin and myosin, in combination with modifying proteins in the extracellular matrix that may have a propensity to bind calcium per se or to induce calcification (as by partially cleaving such proteins and/or reducing cyclizing S-S bonds followed by alkylating); as a result of such treatment, overall calcification of BHV tissue is found to be very effectively reduced. Moreover, testing has shown that treatment with two agents in categories one and two, i.e. a combination of a calcium-channel-blocking agent and an antioxidant and/or enzyme inhibitor, may be more effective than either treatment alone. Furthermore, certain of the treatments described with respect to one class may also have some beneficial effects upon targets from the other class. For example, treatment with CAP, in addition to protecting targeted cells, also inhibits the action of MMPs and phosphatases; similarly, treatment with CB or by DTT/NEM may also have an anticalcification effect upon certain cell-derived substrates.

The following examples illustrate the effectiveness of treatments carried out using some of the preferred embodiments of the invention.

**EXAMPLE 1 - Cell Targeted Treatment**

Multiple samples of porcine aortic roots were fixed and treated as follows:

- (a) Glutaraldehyde - Samples were treated with 0.2% glutaraldehyde in phosphate-buffered saline, pH 7.4,

- for 12 days at room temperature. Tissues were then sterilized for 24 hours at 37°C using 1% glutaraldehyde, 20% isopropanol in phosphate-buffered saline, pH 7.4, followed by 24 hours incubation at 40°C in 0.2% glutaraldehyde in phosphate-buffered saline, pH 7.4, and then stored in the same solution;
- 5 (b) Glutaraldehyde plus 2-aminooleic acid - additional samples were treated with 0.2% glutaraldehyde in phosphate-buffered saline, pH 7.4, for 12 days at room temperature followed by incubation in an aqueous buffered solution of 2-aminooleic acid according to the '733 patent, and then rinsed. Tissues were then sterilized for 24 hours at 37°C in 15 1% glutaraldehyde, 20% isopropanol in borate-buffered saline, pH 7.4, followed by 24 hours incubation at 40°C in 0.2% glutaraldehyde in borate-buffered saline, pH 7.4, and stored in the same solution;
- 20 (c) Glutaraldehyde plus 2-aminooleic acid plus CAP - additional samples were treated with 0.2% glutaraldehyde in phosphate-buffered saline, pH 7.4, for 12 days at room temperature, followed by treatment with aminooleic acid (as above), followed 25 by incubation in 50 mM CAP in borate-buffered saline, pH 7.4, in 10% isopropanol for 24 hours at 37°C and then rinsed. Tissues were then sterilized for 24 hours at room temperature in 1% glutaraldehyde, 20% isopropanol in borate-buffered 30 saline, pH 7.4, followed by 24 hours incubation at 40°C in 0.2% glutaraldehyde in borate-buffered saline, pH 7.4, and stored in the same solution;
- (d) Glutaraldehyde/AOA plus NIF - additional tissues were treated as in Example 1 group(b) (in which 35 tissues were glutaraldehyde-fixed, then treated with 2-aminooleic acid). Tissues were then rinsed and incubated in 5 mM NIF in borate buffer saline, pH 7.4, containing 20% isopropanol for 24 hours at

- 37°C. After rinsing in borate buffer saline, pH 7.4, containing 20% isopropanol, tissues were sterilized in 1% glutaraldehyde 20% isopropanol in borate buffer saline, pH 7.4 for 24 hours at 37°C, followed by 24 hours incubation at 40°C in 0.2% glutaraldehyde in borate buffer saline, pH 7.4, and then stored in the same solution.
- 5
- (e) EDC(sulfo-NHS)-type fixation - Additional tissues first fixed according to the teaching of the '339 patent using EDC plus sulfo-NHS and hexanediamine and/or suberic acid in HEPES buffer, and then sterilized according to U.S. patent number 5,911,951, e.g., by incubation for 24 hours at 40°C in 25 mM EDC, 20% isopropanol in 10 mM HEPES, pH 6.5, and stored in the same solution;
- 10
- (f) EDC(sulfo-NHS)-type fixation plus CAP - Additional tissue was fixed with EDC(sulfo-NHS) as indicated above and then further incubated in 50 mM CAP in 10 mM HEPES, pH 6.5, in 10% isopropanol for 24 hours at 37°C and then rinsed. Tissues were then sterilized according to the '951 patent and stored in the same solution; and
- 15
- (g) EDC/sulfo-NHS-fixed plus NIF - additional tissues were fixed as in Example 1 group(e) (in which tissues were fixed using the EDC/sulfo-NHS process). Tissues were then rinsed and incubated in 5 mM NIF in HEPES buffered saline, pH 6.5, containing 20% isopropanol, for 24 hours at 37°C. After rinsing in HEPES buffer saline, pH 6.5, containing 20% isopropanol, tissues were sterilized according to the '951 patent and stored in the same solution.
- 20
- 25
- 30

Following undergoing the foregoing treatments, the sterilized roots were washed in normal saline, and cusps were dissected away from the aortic walls. For calcification studies, 20 wall coupons and 20 cusp halves were randomly selected from each experimental condition; they were implanted subdermally in three-week old, male

35

Wistar rats. Samples were explanted at 4 and 8 weeks, and calcium was quantitated by Atomic Absorbtion Spectrophotometry (AAS). Selected samples from each experimental condition were processed for histology and stained with hematoxylin and eosin (H&E) for cells, and with von Kossa reagent for calcium deposits. The results are set forth in the table that follows.

## RESULTS

Table 1

		Mean $\pm$ SEM (milligrams calcium/gram dry tissue)			
		Walls		Cusps	
10	Treatment	4-week	8-week	4-week	8-week
	Group a	64.0 $\pm$ 5.0	114.0 $\pm$ 16	53.0 $\pm$ 4.0	155 $\pm$ 30
	Group b	50.1 $\pm$ 6.0	99.6 $\pm$ 5.0	5.2 $\pm$ 1.0	5.6 $\pm$ 1.0
	Group c	5.2 $\pm$ 2.0	21.5 $\pm$ 3.0	3.7 $\pm$ 1.0	3.5 $\pm$ 1.0
	Group d	7.8 $\pm$ 4.0	18.7 $\pm$ 7.0	2.7 $\pm$ 1.3	2.3 $\pm$ 0.6
15	Group e	63.2 $\pm$ 6.0	100.0 $\pm$ 7.0	2.8 $\pm$ 0.9	2.9 $\pm$ 1.0
	Group f	2.6 $\pm$ 1.1	8.0 $\pm$ 3.0	1.7 $\pm$ 0.3	1.9 $\pm$ 0.6
	Group g	0.3 $\pm$ 0.1	8.9 $\pm$ 3.0	0.5 $\pm$ 0.3	0.7 $\pm$ 0.2

The results indicate that post-fixation treatment of wall tissue with CAP, i.e., groups (c) and (f), significantly reduces the calcification compared to wall tissue of groups (b) and (e). In (b), wall tissue samples had been fixed and then treated with 2-aminooleic acid, and in group (e), wall tissue samples had been fixed according to the '339 patent. Moreover, the treatment does not compromise the earlier established calcification resistance of the cusps created by such prior treatment, but instead it may actually slightly improve the resistance of the cusps. Similar results were obtained in the case of post-fixation treatments with 5 mM NIF, i.e. groups (d) and (g), and are also obtained when 5 mM DIL is used.



In all samples screened from each experimental condition, histology revealed the absence of inflammatory reactions (H&E), while von Kossa reagent staining essentially confirmed the calcium analysis results.

5 Alternatively, a pre-fixation treatment to accomplish actin and myosin extraction using KMA was shown to reduce the number of such cells in calcification-prone areas in the wall tissue, but it proved less effective than those treatments detailed in the above-reported tests in  
10 increasing calcification resistance.

The foregoing results suggest that targeting cell calcification by treating with calcium-blocking agents or oxidative damage-preventing agents or with other modifying or extracting agents can significantly reduce  
15 aortic wall calcification.

**EXAMPLE 2 - Extracellular Matrix Targeted Treatments**

Multiple samples of porcine aortic roots were fixed and treated as follows.

- 20 (a) Glutaraldehyde - Samples as treated as in case of group(a) for Example 1.
- (b) Glutaraldehyde plus aminooleic acid - Samples as treated as in case of group(b) for Example 1.
- 25 (c) Glutaraldehyde plus 2-aminooleic acid plus CB - Samples were treated with 0.2% glutaraldehyde in phosphate-buffered saline, pH 7.4, for 12 days at room temperature, followed by treatment with aminooleic acid (as above), followed by incubation in 18.8 mM CB in borate-buffered saline, pH 7.4, for 3 hours at 37°C, and then rinsed. Tissues were  
30 sterilized for 24 hours at room temperature in 1% glutaraldehyde, 20% isopropanol in borate-buffered saline, pH 7.4, followed by 24 hours incubation at 40°C in 0.2% glutaraldehyde in borate-buffered saline, pH 7.4, and stored in the same solution.
- 35 (d) EDC(sulfo-NHS)-type fixation - Samples were treated as in case of group (e) for Example 1.
- (e) EDC(sulfo-NHS)-type fixation plus CB - Additional tissue was fixed using EDC and sulfo-NHS as

indicated above and then further incubated in 18.8 mM CB in 10 mM HEPES, pH 6.5, for 3 hours at 37°C. Tissues were then sterilized according to the '951 patent and stored in the same solution.

5 Following the foregoing treatments, the sterilized roots were washed in normal saline, and cusps were dissected away from the aortic walls. For calcification studies, 20 wall coupons and 20 cusp halves were randomly selected from each experimental condition and were  
10 implanted subdermally in three-week old, male Wistar rats. Samples were explanted at 4 and 8 weeks, and calcium was quantitated by AAS. Selected samples from each experimental condition were processed for histology and stained as in Example 1. The results are tabulated  
15 in the table which follows.

## RESULTS

Table 2

Treatment	Mean $\pm$ SEM (milligrams calcium/gram dry tissue)			
	Walls		Cusps	
	4-week	8-week	4-week	8-week
Group a	65.5 $\pm$ 6.0	111.0 $\pm$ 14	58.0 $\pm$ 5.0	165 $\pm$ 28
20 Group b	58.3 $\pm$ 5.0	109.5 $\pm$ 5.0	5.2 $\pm$ 1.0	5.1 $\pm$ 1.2
Group c	7.9 $\pm$ 3.0	22.6 $\pm$ 3.0	3.5 $\pm$ 0.8	3.8 $\pm$ 1.0
Group d	60.0 $\pm$ 6.0	102.0 $\pm$ 8.0	2.5 $\pm$ 0.8	5.0 $\pm$ 1.0
Group e	8.9 $\pm$ 1.1	20.2 $\pm$ 3.0	4.2 $\pm$ 1.0	3.3 $\pm$ 0.8

The results indicate that post-fixation treatment  
25 with CB, i.e., groups (c) and (e), reduces the calcification of wall tissue that has been either treated with glutaraldehyde and 2-aminooleic acid or fixed according to the '339 patent, without increasing calcification of the corresponding cusps. Studies on  
30 calcification of purified elastic fibers obtained from aortic walls confirmed the efficacy of CB treatment as an anticalcification treatment. Moreover, shrinkage temperature for the fixed cusps was not significantly

affected by the CB treatment, indicating that cross-link density was not significantly reduced by treatment with CB. Histology revealed little, if any, inflammatory reactions in all samples screened from each experimental condition, and von Kossa staining confirmed the calcium quantitation results. Alternative testing showed that similar post-fixation modification of aortic wall tissue with DTT/NEM was also effective in reducing calcification; however, it was not as effective in one particular test as treatment with CB, which is presently preferred.

The results of this testing indicate that matrix components, such as EAMF proteins, MMPs, and other calcium-binding components can be effectively chemically modified in a manner so as to reduce aortic wall calcification.

**EXAMPLE III - Combination of Targeted Treatments**

Multiple samples of porcine aortic wall segments were fixed and treated as follows.

- (a) Glutaraldehyde/AOA - additional tissue was treated as in Example 1 group(b) (in which the tissues were glutaraldehyde-fixed, then treated with aminooleic acid, followed by sterilization).
- (b) Glutaraldehyde/AOA plus CAP plus NIF - additional tissue was treated as in Example 1 group(c) (in which tissues were glutaraldehyde-fixed, then treated with aminooleic acid, followed by treatment with the CAP). Tissues were then rinsed and incubated for 24 hours at 37°C in 5 mM NIF in borate buffer saline, pH 7.4, containing 20% isopropanol. After rinsing in borate buffer saline, pH 7.4, containing 20% isopropanol, tissues were sterilized for 24 hours at 37°C in 1% glutaraldehyde and 20% isopropanol in borate buffer saline, pH 7.4, followed by 24 hours incubation at 40°C in 0.2% glutaraldehyde in borate buffer saline, pH 7.4, and stored in the same solution.

- (c) Glutaraldehyde/AOA plus CB plus CAP - additional tissue was treated as in Example 2 group(c) - (in which tissues were glutaraldehyde-fixed, then treated with aminooleic acid, and then treated with CB). Tissues were further rinsed and incubated for 24 hours at 37°C in 50 mM CAP in borate buffer saline, pH 7.4, containing 10% isopropanol. After rinsing, the tissues were sterilized for 24 hours at 37°C in 1% glutaraldehyde and 20% isopropanol in borate buffer saline, pH 7.4, followed by 24 hours incubation at 40°C in 0.2% glutaraldehyde in borate buffer saline, pH 7.4, and stored in the same solution.
- (d) Glutaraldehyde/AOA plus CB plus NIF - additional tissue was treated as in Example 2 group(c) - (in which tissues were glutaraldehyde-fixed, then treated with aminooleic acid, and then treated with CB). Tissues were further rinsed and incubated for 24 hours at 37°C in 5 mM NIF in borate buffer saline, pH 7.4, containing 20% isopropanol. After rinsing, the tissues were sterilized for 24 hours at 37°C in 1% glutaraldehyde and 20% isopropanol in borate buffer saline, pH 7.4, followed by 24 hours incubation at 40°C in 0.2% glutaraldehyde in borate buffer saline, pH 7.4, and stored in the same solution.
- (e) EDC/sulfo-NHS - additional tissue was treated as in Example 1 group(e) (in which tissues were fixed with the EDC sulfo-NHS process, followed by sterilization).
- (f) EDC/sulfo-NHS plus CAP plus NIF - additional tissue was treated as in Example 1 group(f) (in which tissues were fixed with the EDC sulfo-NHS process, then treated with CAP). Tissues were then rinsed and incubated for 24 hours at 37°C in 5 mM NIF in HEPES buffered saline, pH 6.5, containing 20% isopropanol. After rinsing in HEPES buffer saline, pH 6.5, containing 20% isopropanol, tissues were

sterilized according to the '951 patent and stored in the same solution.

- 5 (g) EDC/sulfo-NHS plus CB plus CAP - additional tissue was treated as in Example 2 group(e) (in which tissues were fixed with the EDC sulfo-NHS process, then treated with CB). Tissues were then rinsed and incubated for 24 hours at 37°C in 50 mM CAP in HEPES buffered saline, pH 6.5, containing 10% isopropanol. After rinsing in HEPES buffer saline, pH 6.5, containing 10% isopropanol, tissues were sterilized according to the '951 patent and stored in the same solution.
- 10
- (h) EDC/sulfo-NHS plus CB plus NIF - additional tissue was treated as in Example 2 group(e) (in which tissues were fixed with the EDC sulfo-NHS process, then treated with CB). Tissues were then rinsed and incubated for 24 hours at 37°C in 5 mM NIF in HEPES buffered saline, pH 6.5, containing 20% isopropanol. After rinsing in HEPES buffer saline, pH 6.5, containing 20% isopropanol, tissues were sterilized according to the '951 patent and stored in the same solution.
- 15
- 20

Following the above-mentioned treatments, the sterilized wall segments were washed in normal saline, and 20 wall coupons were randomly selected from each experimental group and implanted subdermally in rats; they were analyzed for calcification after 4 and 8 weeks as described in Example 1. The results are set forth in the table that follows:

25

## RESULTS

Table 3

		Mean $\pm$ SEM (milligrams calcium/gram dry tissue)	
Treatment		Walls	
		4-week	8-week
5	Group a	49.9 $\pm$ 8.0	114.9 $\pm$ 12.0
	Group b	4.4 $\pm$ 3.5	4.2 $\pm$ 2.1
	Group c	3.9 $\pm$ 2.6	12.0 $\pm$ 8.8
	Group d	1.4 $\pm$ 0.9	3.8 $\pm$ 2.9
	Group e	65.4 $\pm$ 7.0	103.0 $\pm$ 9.0
10	Group f	1.8 $\pm$ 1.2	7.1 $\pm$ 3.1
	Group g	2.3 $\pm$ 0.7	6.7 $\pm$ 3.0
	Group h	3.4 $\pm$ 1.5	4.9 $\pm$ 3.7

The results indicate that post-fixation treatments with CAP followed by NIF, as well as treatments which employ CB followed by CAP or NIF, significantly reduce calcification of wall tissue that has earlier been either treated with glutaraldehyde and aminooleic acid or fixed according to the '399 patent. Histology performed on samples randomly selected from each experimental group revealed the absence of inflammatory reactions, and von Kossa staining confirmed the calcium quantitation results.

By comparing the 8-week calcium results from Example 3 with the comparable results in Examples 1 and 2, the data indicate that the effect of certain combinations of targeted treatments can reduce wall calcification to a higher extent than either treatment alone. For example, calcification of glutaraldehyde- and aminooleic acid-treated walls at 8-week post-implantation was reduced to 22.6 $\pm$ 3 milligrams of calcium/gram dry tissue by treatment with CB alone (Example 2, group c) and to 18.7 $\pm$ 7.0 milligrams of calcium/gram dry tissue by treatment with

NIF alone (Example 1, group d), while treatment with CB, followed by treatment with NIF, reduced calcium levels to  $3.8 \pm 2.9$  milligrams of calcium/gram dry tissue (Example 3, group d).

5           These data suggest that the major determinants of wall calcification are related to both cells and components of the extracellular matrix. As a result, it now appears that multiple targeting of relevant calcifying substrates can still further significantly  
10 reduce aortic wall calcification.

          Although the invention has been described with regard to certain preferred embodiments which constitute the best mode presently known to the inventors for carrying out the invention, it should be understood that  
15 various changes and modifications that would be obvious to one having the ordinary skill in this art may be made without deviating from the scope of the invention as set forth in the claims appended hereto. For example, although various sequences of treatment are set forth, in  
20 many instances, the steps can be carried out in different sequences and still obtain the advantageous anticalcification characteristics in the ultimate products. Although washing between steps is considered desirable to avoid any potential interaction between  
25 reagents, if there is no such interaction expected, such washing step may be omitted. Moreover, some reagents may be fully compatible with each other, in which case a combination of treatments may be performed simultaneously, and as such, simultaneous treatment is  
30 often considered to be the equivalent of sequential treatment with agents from certain categories. Likewise, although the working examples show treatment of cardiovascular tissues, i.e. porcine aortic roots with walls and cusps or porcine aortic wall segments alone,  
35 such was done for purposes of allowing reasonable comparison, and it should be understood, as set forth in the description, that the invention is considered to be applicable to a wide variety of biomaterials destined for

implantation in mammals, particularly humans, where calcification is considered to be a distinct problem because of its adverse effect on ultimate lifetime.

The disclosures of the previously enumerated U.S.  
5 patents are expressly incorporated by reference.

Particular features of the invention are set forth in the claims that follow.



## CLAIMS:

1. A method for the treatment of biomaterials destined for implantation in mammals, including humans, which method comprises:

(a) treating said biomaterial with an effective amount of a cell-targeted agent, which agent (i) decreases calcification by blocking calcium channels, (ii) prevents oxidative or selective enzymatic damage and/or (iii) removes cell-derived calcium-binding components; followed by washing said treated biomaterial; or

(b) treating said biomaterial with an effective amount of a matrix-targeted agent which chemically modifies proteins in matrix-derived components thereof that bind calcium or that induce calcification in adjacent components, followed by washing said treated biomaterial; or

(c) sequentially treating said biomaterial with a combination of (a) followed by (b) or of (b) followed by (a) with an intermediate washing step being optional, whereby said treated and washed biomaterial thereafter resists *in vivo* calcification.

2. The method according to claim 1 wherein treating is carried out according to step (a)(ii) using a concentration of between about 1 and about 200 mM of an antihypertensive agent which prevents oxidative and/or enzymatic damage.

3. The method according to claim 2 wherein a concentration of captopril between about 25 and about 75 mM is employed.

4. The method according to any one of claims 1-3 wherein treating is carried out in accordance with step (a)(i) using a concentration of between about 0.1 and about 50 mM of a calcium channel-blocking agent.

5. The method according to claim 4 wherein a concentration of between about 5 and about 25 mM of nifedipine or diltiazem hydrochloride is used.

6. The method of any one of claims 1-5 wherein treating is carried out according to step (b) using a protein cleaving agent at a concentration of between about 1 and about 200 mM.

7. The method according to claim 6 wherein a concentration of about 10 and about 50 mM of cyanogen bromide is used.

8. The method according to claim 6 wherein, following treatment according to step (b), said biomaterial is treated according to step (a)(i).

9. The method according to claim 6 wherein, following treatment in accordance with step (b), said biomaterial is treated in accordance with step (a)(ii), and optionally then treated according to step (a)(i).

10. The method according to any one of claims 1-9 wherein treating is carried out according to step(a)(iii) using KMA at a KCl concentration of between about 0.5-0.8 M and MgATP at a concentration of between about 0.05 and about 8 mM.

11. The method according to any one of claims 1-10 wherein step (b) is carried out using a reducing agent at a concentration of between about 1 and about 200 mM.

12. The method according to claim 11 wherein step (b) is carried out using a concentration of between about 25 and about 75 mM of DTT and is followed by treatment with an alkylating agent.

13. A method for the treatment of chemically cross-linked cardiovascular tissues prior to implantation in the human body, which method comprises:

(a) treating said tissue with an effective amount of a cell-targeted agent which decreases calcification by blocking calcium channels, and then washing said treated tissue; or

(b) treating said tissue with an effective amount of a cell-targeted agent which decreases calcification by preventing oxidative and enzymatic damage, and then washing said treated tissue; or

(c) treating said tissue with an effective amount of KMA which removes cell-derived calcium binding proteins, and then washing said treated tissue; or

(d) treating said tissue with an effective amount of a matrix-targeted agent which chemically modifies proteins in matrix-derived components that bind calcium or that induce calcification in adjacent components, and then washing said treated tissue; or

(e) sequentially treating said tissue with a combination of at least two of steps (a), (b), (c) and (d) with intermediate washing being optional between any sequence of two such steps ; and

(f) sterilizing said treated and washed tissue,

whereby said treated, washed and sterilized tissue thereafter resists *in vivo* calcification.

14. The method according to claim 13 wherein treating is carried out according to step (a) using a concentration of between about 5 and about 25 mM of nifedipine or diltiazem hydrochloride.

15. The method according to either claim 13 or 14 wherein treating is carried out in accordance with step (b) using a concentration of captopril between about 25 and about 75 mM.

16. The method according to claim 15 wherein, following treatment in accordance with step (b), said biomaterial is treated in accordance with step (a).

17. The method of any one of claims 13-16 wherein treating is carried out according to step (d) using a concentration of between about 25 and about 75 mM of DTT followed by treatment with an alkylating agent.

18. The method of any one of claims 13-17 wherein treating is carried out according to step (d) using a concentration of about 10 and about 50 mM of cyanogen bromide.

19. The method according to claim 13 wherein following treatment according to step (d), said biomaterial is treated according to step (b) and following treatment according to step (b), said biomaterial is optionally treated according to step (a).

20. The method according to claim 13 wherein there is sequential treatment of said tissue in the form of one of the following combinations: (a) followed by (b); (b) followed by (a); (c) followed by (b); (c) followed by (a); or (c) followed by (a) and (b).

(12) INTERNATIONAL APPLICATION PUBLISHED UNDER THE PATENT COOPERATION TREATY (PCT)

(19) World Intellectual Property Organization  
International Bureau



(43) International Publication Date  
12 June 2003 (12.06.2003)

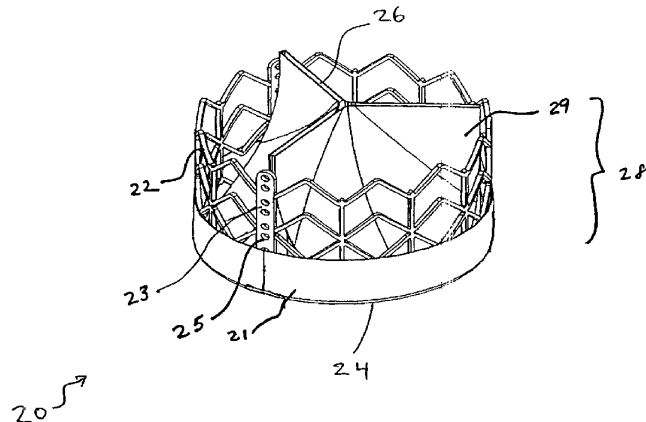
PCT

(10) International Publication Number  
WO 03/047468 A1

- (51) International Patent Classification<sup>7</sup>: A61F 2/24 (74) Agent: DIPPERT, William, H.; Reed Smith LLP, 29th floor, 599 Lexington Avenue, New York, NY 10022 (US).
- (21) International Application Number: PCT/US02/32588
- (22) International Filing Date: 11 October 2002 (11.10.2002) (81) Designated States (*national*): AE, AG, AL, AM, AT, AU, AZ, BA, BB, BG, BR, BY, BZ, CA, CH, CN, CO, CR, CU, CZ, DE, DK, DM, DZ, EC, EE, ES, FI, GB, GD, GE, GH, GM, HR, HU, ID, IL, IN, IS, JP, KE, KG, KP, KR, KZ, LC, LK, LR, LS, LT, LU, LV, MA, MD, MG, MK, MN, MW, MX, MZ, NO, NZ, OM, PH, PL, PT, RO, RU, SD, SE, SG, SI, SK, SL, TJ, TM, TN, TR, TT, TZ, UA, UG, US, UZ, VN, YU, ZA, ZM, ZW.
- (25) Filing Language: English
- (26) Publication Language: English
- (30) Priority Data: 09/975,750 11 October 2001 (11.10.2001) US
- (71) Applicant (*for all designated States except US*): PERCUTANEOUS VALVE TECHNOLOGIES [US/US]; 2050 Center Avenue, Suite 565, Fort Lee, NJ 07024 (US). (84) Designated States (*regional*): ARIPO patent (GH, GM, KE, LS, MW, MZ, SD, SL, SZ, TZ, UG, ZM, ZW), Eurasian patent (AM, AZ, BY, KG, KZ, MD, RU, TJ, TM), European patent (AT, BE, BG, CH, CY, CZ, DE, DK, EE, ES, FI, FR, GB, GR, IE, IT, LU, MC, NL, PT, SE, SK, TR), OAPI patent (BF, BJ, CF, CG, CI, CM, GA, GN, GQ, GW, ML, MR, NE, SN, TD, TG).
- (72) Inventors; and
- (75) Inventors/Applicants (*for US only*): SPENSER, Benjamin [IL/IL]; Havazelet St. 6, Caeserea (IL). BENICHU, Netanel [IL/IL]; Nir Etzion N.D., Hof-Carmel (IL). BASH, Assaf [IL/IL]; Hasseora St. 1, 37808 Givat Ada (IL). ZAKAI, Avraham [IL/IL]; Yair St. 13, Zichon Yaacov (IL).
- Published:  
— with international search report

[Continued on next page]

(54) Title: IMPLANTABLE PROSTHETIC VALVE



(57) Abstract: A valve prosthesis device (20) is disclosed suitable for implantation in body ducts. The device comprises a support stent (22), comprised of a deployable construction adapted to be initially crimped in a narrow configuration suitable for catheterization through the body duct to a target location and adapted to be deployed by exerting substantially radial forces from within by means of a deployment device (48) to a deployed state in the target location, and a valve assembly (28) comprising a flexible conduit having an inlet end (24) and an outlet (26), made of pliant material (29) attached to the support beams (23) providing collapsible slack portions of the conduit at the outlet. The support stent is provided with a plurality of longitudinally rigid support beams (23) of fixed length. When flow is allowed to pass through the valve prosthesis device from the inlet to the outlet, the valve assembly is kept in an open position, whereas a reverse flow is prevented as the collapsible slack portions of the valve assembly collapse inwardly providing blockage to the reverse flow.

WO 03/047468 A1

**WO 03/047468 A1**



---

*For two-letter codes and other abbreviations, refer to the "Guidance Notes on Codes and Abbreviations" appearing at the beginning of each regular issue of the PCT Gazette.*

## **IMPLANTABLE PROSTHETIC VALVE**

### **FIELD OF THE INVENTION**

The present invention relates to implantable devices. More particularly, it relates to a valve prosthesis for cardiac implantation or for implantation in other body ducts.

### **BACKGROUND OF THE INVENTION**

There are several known prosthetic valves that have been previously described. U.S. Patent No. 5,411,552 (Andersen et al.), entitled VALVE PROSTHESIS FOR IMPLANTATION IN THE BODY AND CATHETER FOR IMPLANTING SUCH VALVE PROSTHESIS, discloses a valve prosthesis comprising a stent made from an expandable cylinder-shaped thread structure comprising several spaced apices. The elastically collapsible valve is mounted on the stent with the commissural points of the valve secured to the projecting apices, which prevents the valve from turning inside out. Deployment of the valve can be achieved by using an inflatable balloon which in its deflated state is used to carry about it the valve structure to its position and, when inflated, deploys the stent in position to its final size. See, also, U.S. Patent No. 6,168,614 (Andersen et al.) entitled VALVE PROSTHESIS FOR IMPLANTATION IN THE BODY and U.S. Patent No. 5,840,081 (Andersen et al.), entitled SYSTEM AND METHOD FOR IMPLANTING CARDIAC VALVES.

In PCT/EP97/07337 (Letac, Cribier et al.), published as WO 98/29057, entitled VALVE PROSTHESIS FOR IMPLANTATION IN BODY CHANNELS, there is disclosed a valve prosthesis comprising a collapsible valve structure and an expandable frame on which the valve structure is mounted. The valve structure is composed of a valvular tissue compatible with the human body and blood, the valvular tissue being sufficiently supple and resistant to allow the valve structure to be deformed from a closed state to an opened state. The valvular tissue forms a continuous surface and is provided with guiding means formed or incorporated within, the guiding means creating stiffened zones which induce the valve structure to follow a patterned movement in its expansion to its opened state and in its turning back to its closed state. The valve structure can be

extended to an internal cover which is fastened to the lower part of the valve structure to prevent regurgitation.

There are several known methods currently used for replacing aortic valves and several types of artificial prosthetic devices. Mechanical valves are commonly used in several different designs (single and double flap) manufactured by well-known companies such as St. Jude, Medtronic, Sulzer, and others. Some of the main disadvantages of these devices are: a need for permanent treatment of anticoagulants, noisy operation, and a need for a large-scale operation to implant.

There is a wide range of biologically based valves made of natural valves or composed of biological materials such as pericardial tissue. These too are made and marketed by well-known companies such as Edwards Lifesciences, Medtronic, Sulzer, Sorin, and others.

Polymer valves are new and are not yet in use, but several companies are in the process of developing such products. A new type of prosthesis is being considered, based on artificial polymer materials such as polyurethane..

The present invention introduces several novel structural designs for implantable valves. An aspect of the present invention deals with the possibility of implanting the valve percutaneously, i.e., inserting the valve assembly on a delivery device similar to a catheter, then implanting the valve at the desired location via a large blood vessel such as the femoral artery, in a procedure similar to other known interventional cardiovascular procedures. The percutaneous deployment procedure and device has an impact on the product design in several parameters, some of which are explained hereinafter.

The percutaneous implantation of medical devices and particularly prosthetic valves is a preferred surgical procedure for it involves making a very small perforation in the patient's skin (usually in the groin or armpit area) under local anesthetic and sedation, as opposed to a large chest surgery incision, which requires general anesthesia, opening a



large portion of the chest, and cardiopulmonary bypass. This percutaneous procedure is therefore considered safer.

The present invention provides a series of new concepts in the field of aortic valves and other human valves.

#### SUMMARY OF THE INVENTION

It is therefore thus provided, in accordance with a preferred embodiment of the present invention, a valve prosthesis device suitable for implantation in body ducts, the device comprising:

a support stent, comprised of a deployable construction adapted to be initially crimped in a narrow configuration suitable for catheterization through the body duct to a target location and adapted to be deployed by exerting substantially radial forces from within by means of a deployment device to a deployed state in the target location, the support stent provided with a plurality of longitudinally rigid support beams of fixed length; and

a valve assembly comprising a flexible conduit having an inlet end and an outlet, made of pliant material attached to the support beams providing collapsible slack portions of the conduit at the outlet,

whereby when flow is allowed to pass through the valve prosthesis device from the inlet to the outlet the valve assembly is kept in an open position, whereas a reverse flow is prevented as the collapsible slack portions of the valve assembly collapse inwardly providing blockage to the reverse flow.

Furthermore, in accordance with another preferred embodiment of the present invention, the support stent comprises an annular frame.

Furthermore, in accordance with another preferred embodiment of the present invention, said valve assembly has a tricuspid configuration.

Furthermore, in accordance with another preferred embodiment of the present invention, said valve assembly is made from biocompatible material.

Furthermore, in accordance with another preferred embodiment of the present invention, the valve assembly is made from pericardial tissue, or other biological tissue.

Furthermore, in accordance with another preferred embodiment of the present invention, said valve assembly is made from biocompatible polymers.

Furthermore, in accordance with another preferred embodiment of the present invention, the valve assembly is made from materials selected from the group consisting of polyurethane and polyethylene terephthalate (PET).

Furthermore, in accordance with another preferred embodiment of the present invention, said valve assembly comprises a main body made from PET (polyethylene terephthalate) and leaflets made from polyurethane.

Furthermore, in accordance with another preferred embodiment of the present invention, said support stent is made from nickel titanium.

Furthermore, in accordance with another preferred embodiment of the present invention, the support beams are substantially equidistant and substantially parallel so as to provide anchorage for the valve assembly.

Furthermore, in accordance with another preferred embodiment of the present invention, the support beams are provided with bores so as to allow stitching or tying of the valve assembly to the beams.

Furthermore, in accordance with another preferred embodiment of the present invention, the support beams are chemically adhered to the support stent.

Furthermore, in accordance with another preferred embodiment of the present invention, said valve assembly is riveted to the support beams.

Furthermore, in accordance with another preferred embodiment of the present invention, said valve assembly is stitched to the support beams.

Furthermore, in accordance with another preferred embodiment of the present invention, said beams are manufactured by injection using a mold, or by machining.

Furthermore, in accordance with another preferred embodiment of the present invention, said valve assembly is rolled over the support stent at the inlet.

Furthermore, in accordance with another preferred embodiment of the present invention, said valve device is manufactured using forging or dipping techniques.

Furthermore, in accordance with another preferred embodiment of the present invention, said valve assembly leaflets are longer than needed to exactly close the outlet, thus when they are in the collapsed state substantial portions of the leaflets fall on each other creating better sealing.

Furthermore, in accordance with another preferred embodiment of the present invention, said valve assembly is made from coils of a polymer, coated by a coating layer of same polymer.

Furthermore, in accordance with another preferred embodiment of the present invention, said polymer is polyurethane.

Furthermore, in accordance with another preferred embodiment of the present invention, the support stent is provided with heavy metal markers so as to enable tracking and determining the valve device position and orientation.

Furthermore, in accordance with another preferred embodiment of the present invention, the heavy metal markers are selected from gold, platinum, iridium, or tantalum.

Furthermore, in accordance with another preferred embodiment of the present invention, the valve assembly leaflets are provided with radio-opaque material at the outlet, so as to help tracking the valve device operation *in vivo*.

Furthermore, in accordance with another preferred embodiment of the present invention, said radio-opaque material comprises gold thread.

Furthermore, in accordance with another preferred embodiment of the present invention, the diameter of said support stent, when fully deployed is in the range of from about 19 to about 25 mm.

Furthermore, in accordance with another preferred embodiment of the present invention, the diameter of said support stent may be expanded from about 4 to about 25 mm.

Furthermore, in accordance with another preferred embodiment of the present invention, the support beams are provided with bores and wherein the valve assembly is attached to the support beams by means of U-shaped rigid members that are fastened to

the valve assembly and that are provided with extruding portions that fit into matching bores on the support beams.

Furthermore, in accordance with another preferred embodiment of the present invention, the support beams comprise rigid support beams in the form of frame construction, and the valve assembly pliant material is inserted through a gap in the frame and a fastening rod is inserted through a pocket formed between the pliant material and the frame and holds the valve in position.

Furthermore, in accordance with another preferred embodiment of the present invention, the main body of the valve assembly is made from coiled wire coated with coating material.

Furthermore, in accordance with another preferred embodiment of the present invention, the coiled wire and the coating material is made from polyurethane.

Furthermore, in accordance with another preferred embodiment of the present invention, a strengthening wire is interlaced in the valve assembly at the outlet of the conduit so as to define a fault line about which the collapsible slack portion of the valve assembly may flap.

Furthermore, in accordance with another preferred embodiment of the present invention, the strengthening wire is made from nickel titanium alloy.

Furthermore, in accordance with another preferred embodiment of the present invention, there is provided a valve prosthesis device suitable for implantation in body ducts, the device comprising a main conduit body having an inlet and an outlet and pliant leaflets attached at the outlet so that when a flow passes through the conduit from the inlet to the outlet the leaflets are in an open position allowing the flow to exit the outlet, and when the flow is reversed the leaflets collapse so as to block the outlet, wherein the main body is made from PET and collapsible leaflets are made from polyurethane.

Furthermore, in accordance with another preferred embodiment of the present invention, support beams made from polyurethane are provided on the main body and wherein the leaflets are attached to the main body at the support beams.

Furthermore, in accordance with another preferred embodiment of the present invention, said support beams are chemically adhered to the main body.

Furthermore, in accordance with another preferred embodiment of the present invention, there is provided a valve prosthesis device suitable for implantation in body ducts, the device comprising:

a support stent, comprised of a deployable construction adapted to be initially crimped in a narrow configuration suitable for catheterization through the body duct to a target location and adapted to be deployed by exerting substantially radial forces from within by means of a deployment device to a deployed state in the target location, the support stent provided with a plurality of longitudinally rigid support beams of fixed length;

a valve assembly comprising a flexible conduit having an inlet end and an outlet, made of pliant material attached to the support beams providing collapsible slack portions of the conduit at the outlet; and

substantially equidistant rigid support beams interlaced or attached to the slack portion of the valve assembly material, arranged longitudinally.

Furthermore, in accordance with another preferred embodiment of the present invention, there is provided a crimping device for crimping the valve device described above or in Claim 1, the crimping device comprising a plurality of adjustable plates that resemble a typical SLR (Single Lens Reflex) camera variable restrictor, each provided with a blade, that are equally dispersed in a radial symmetry but each plate moves along a line passing off an opening in the center, all plates equidistant from that center opening.

Furthermore, in accordance with another preferred embodiment of the present invention, the multiple plates are adapted to move simultaneously by means of a lever and transmission.

Furthermore, in accordance with another preferred embodiment of the present invention, there is provided a method for deploying an implantable prosthetic valve device from the retrograde approach (approaching the aortic valve from the descending aorta) or from the antegrade approach (approaching the aortic valve from the left ventricle after performing a trans-septal puncture) at the natural aortic valve position at the entrance to the left ventricle of a myocardium of a patient, the method comprising the steps of:

(a) providing a balloon catheter having a proximal end and a distal end, having a first and second independently inflatable portions, the first inflatable portion located at the distal end of the catheter and the second inflatable portion adjacently behind the first inflatable portion;

(b) providing a guiding tool for guiding the balloon catheter in the vasculature of the patient;

(c) providing a deployable implantable valve prosthesis device adapted to be mounted on the second inflatable portion of the balloon catheter;

(d) for the retrograde approach, guiding the balloon catheter through the patient's aorta using the guiding tool, the valve device mounted over the second inflatable portion of the balloon catheter until the first inflatable portion of the balloon catheter is inserted into the left ventricle, whereas the second inflatable portion of the balloon catheter is positioned at the natural aortic valve position;

(e) for the antegrade approach, guiding the balloon catheter through the patient's greater veins, right atrium, left atrium, and left ventricle using the guiding tool, the valve device mounted over the second inflatable portion of the balloon catheter until the first inflatable portion of the balloon catheter is inserted into the left ventricle,

whereas the second inflatable portion of the balloon catheter is positioned at the natural aortic valve position;

(f) inflating the first inflatable portion of the balloon catheter so as to substantially block blood flow through the natural aortic valve and anchor the distal end of the balloon catheter in position;

(g) inflating the second inflatable portion of the balloon catheter so as to deploy the implantable prosthetic valve device in position at the natural aortic valve position;

(h) deflating the first and second inflatable portions of the balloon catheter; and

(i) retracting the balloon catheter and removing it from the patient's body.

Furthermore, in accordance with another preferred embodiment of the present invention, the guiding tool comprises a guide wire.

Furthermore, in accordance with another preferred embodiment of the present invention, there is provided a method for deploying an implantable prosthetic valve device at the natural aortic valve position at the entrance to the left ventricle of a myocardium of a patient, the method comprising the steps of:

(a) providing a balloon catheter having a proximal end and a distal end, having a first and second independently inflatable portions, the first inflatable portion located at the distal end of the catheter and the second inflatable portion adjacently behind the first inflatable portion;

(b) providing a guiding tool for guiding the balloon catheter in the vasculature of the patient;

(c) providing a deployable implantable valve prosthesis device adapted to be mounted on the first inflatable portion of the balloon catheter, and a deployable annular stent device adapted to be mounted over the second inflatable portion of the balloon

catheter, the deployable implantable valve prosthesis device and the deployable annular stent kept at a predetermined distant apart;

(d) guiding the balloon catheter through the patient's aorta using the guiding tool, the valve device mounted over the first inflatable portion of the balloon catheter and the deployable annular stent mounted over the second inflatable portion of the balloon catheter, until the first inflatable portion of the balloon catheter is positioned at the natural aortic valve position;

(e) inflating the second inflatable portion of the balloon catheter so that the deployable stent device is deployed within the aorta thus anchoring the deployable annular stent and the coupled valve device in position;

(f) inflating the first inflatable portion of the balloon catheter so as to deploy the implantable prosthetic valve device in position at the natural aortic valve position;

(g) deflating the first and second inflatable portions of the balloon catheter; and

(h) retracting the balloon catheter and removing it from the patient's body.

Furthermore, in accordance with another preferred embodiment of the present invention, a valve prosthesis device suitable for implantation in body ducts comprises:

an expandable support frame, the support frame provided with a plurality of longitudinally rigid support beams of fixed length; and

a valve assembly comprising a flexible conduit having an inlet end and an outlet, made of pliant material attached to the support beams providing collapsible slack portions of the conduit at the outlet,

whereby when flow is allowed to pass through the valve prosthesis device from the inlet to the outlet the valve assembly is kept in an open position, whereas a reverse



flow is prevented as the collapsible slack portions of the valve assembly collapse inwardly providing blockage to the reverse flow.

Furthermore, in accordance with another preferred embodiment of the present invention, the support frame comprises a deployable construction adapted to be initially crimped in a narrow configuration suitable for catheterization through the body duct to a target location and adapted to be deployed by exerting substantially radial forces from within by means of a deployment device to a deployed state in the target location.

Furthermore, in accordance with another preferred embodiment of the present invention, the support beams have a U-shaped cross section.

Furthermore, in accordance with another preferred embodiment of the present invention, a holder is used to secure the pliant material to the support beams.

Furthermore, in accordance with another preferred embodiment of the present invention, the support frame comprises three segments that form a circular assembly when assembled.

Furthermore, in accordance with another preferred embodiment of the present invention, the support beams point inwardly with respect to a central longitudinal axis of the device.

Furthermore, in accordance with another preferred embodiment of the present invention, the device is further provided with a restricting tapered housing, for housing it in a crimped state.

Furthermore, in accordance with another preferred embodiment of the present invention, hooks are provided to secure the device in position after it is deployed.

Furthermore, in accordance with another preferred embodiment of the present invention, the support beams comprise longitudinal bars having a narrow slit used as the commissural attachment so that extensions the pliant material are tightly inserted through it.

Furthermore, in accordance with another preferred embodiment of the present invention, the extensions of the pliant material are wrapped about rigid bars serving as anchorage means.

Furthermore, in accordance with another preferred embodiment of the present invention, extensions of the pliant material are sutured to each other at the rigid bars.

Furthermore, in accordance with another preferred embodiment of the present invention, a bottom portion of the pliant material is attached to the inlet.

Furthermore, in accordance with another preferred embodiment of the present invention, the support beams are each provided with a rounded pole, forming a loop through which the pliant material is inserted.

Furthermore, in accordance with another preferred embodiment of the present invention, the pliant material is provided with longitudinal bars attached to the pliant material at positions assigned for attachment to the support frame, in order to prevent localized stress from forming.

Furthermore, in accordance with another preferred embodiment of the present invention, the device is further provided with longitudinal bars having protrusions that are inserted in bores in the pliant material, a sheet of PET and through bores provided on the support beams.

Furthermore, in accordance with another preferred embodiment of the present invention, pliant material is sutured leaving the slack portions free of sutures.

Furthermore, in accordance with another preferred embodiment of the present invention, a connecting member with a split portion is used to connect leaflets of the pliant material to the support beams, the split connecting member compressing the pliant material in position.

Furthermore, in accordance with another preferred embodiment of the present invention, a portion of the connecting member is perpendicular to the split portion.

Furthermore, in accordance with another preferred embodiment of the present invention, the support frame is provided with metallic members coupled to the stent and rigid members are positioned on two opposite sides of the metallic member and held against each other holding portion of the pliant material between them, sutured, the metallic members wrapped with PET.

Furthermore, in accordance with another preferred embodiment of the present invention, the device is further provided with spring in order to reduce wear of the pliant material.

Furthermore, in accordance with another preferred embodiment of the present invention, the spring is provided with a spiral.

Furthermore, in accordance with another preferred embodiment of the present invention, the spring is made from stainless steel.

Furthermore, in accordance with another preferred embodiment of the present invention, the spring is attached to slots provided on the support frames.

Furthermore, in accordance with another preferred embodiment of the present invention, the pliant material is sutured to the support frame forming pockets.

Furthermore, in accordance with another preferred embodiment of the present invention, attachment bars are provided on the stent support at a portion of the stent close to the outlet, onto which the pliant material is coupled, and wherein the pliant material is attached circumferentially to the inlet, leaving slack pliant material.

Furthermore, in accordance with another preferred embodiment of the present invention, the outlet is tapered with respect to the inlet.

Furthermore, in accordance with another preferred embodiment of the present invention, the support frame at the outlet is wider in diameter than the pliant material forming the outlet.

Furthermore, in accordance with another preferred embodiment of the present invention, the pliant material is reinforced using PET.

Furthermore, in accordance with another preferred embodiment of the present invention, the support frame is a tube having an inner wall, having sinusoidal fold lines, wherein the pliant material is sutured to the inner wall of the tube along suture lines.

Furthermore, in accordance with another preferred embodiment of the present invention, additional piece of PET is added below the suture lines.

Furthermore, in accordance with another preferred embodiment of the present invention, the device is incorporated with an angioplasty balloon.

Finally, in accordance with another preferred embodiment of the present invention, balloon has a central longitudinal axis that runs along a flow path through the device, and a perimeter, the balloon comprising four inflatable portions, one portion located along a central axis and the other three located on the perimeter, the pliant material in the form of leaflets is distributed about the perimeter.

#### BRIEF DESCRIPTION OF THE FIGURES

To better understand the present invention and appreciate its practical applications, the following Figures are provided and referenced hereafter. It should be noted that the Figures are given as examples only and in no way limit the scope of the invention as defined in the appended claims.

Figure 1 illustrates an implantable prosthetic tricuspid valve in accordance with a preferred embodiment of the present invention, suitable for percutaneous deployment using a stent or similar deploying means, in its deployed-inflated position;

Figure 2 depicts an implantable valve according to the present invention mounted over a deploying stent with an inflatable balloon;

Figure 3 illustrates an implantable valve according to the present invention mounted over a stent with an inflatable balloon, in a crimped position;

Figure 4 depicts implantable valve deployment in a natural aortic valve position in accordance with the present invention;

Figure 5 demonstrates manufacturing a polyurethane implantable valve using a dipping technique according with the present invention;

Figures 6a to 6e illustrate manufacturing of an implantable valve by forging according to the present invention;

Figures 7a and 7b demonstrate composite valve, which has polyurethane (PU) leaflets and PET tubular-crown shaped construction, according to the present invention;

Figures 8a and 8b depict a manufacture process of a composite valve made of flexible PU leaflets, rigid PU construction for mounting and a PET tubular end;

Figures 9 to 9i demonstrate different methods of attachment between the valve and stent according to the present invention;

Figure 10 illustrates a dipping mandrel with an extra portion, which improves the sealing ability of the valve, according to the present invention;

Figures 11a to 11c illustrate a valve mounted on a stent with an extra support, which improves the force distribution on the valve material and facilitates prolonged durability of the valve, according to the present invention;

Figures 12a to 12c depict a valve with rigid supports according to the present invention, located substantially in the center of its leaflets. This design allows the valve leaflets to perform without outer support;

Figures 13a to 13c illustrate the manufacturing of a reinforced PU tube composed of strong fiber from PU, PET or other and a softer PU coating, for serving as the supporting structure;

Figures 14a to 14c demonstrate incorporation of heavy metal markers on the stent, according to the present invention. These markers allow orientation control while positioning the device at the required location;

Figures 15a to 15c demonstrate a valve with radio-opaque coating, according to the present invention, which allows imaging of the valve motion under angiogram;

Figures 16a to 16c illustrate a procedure, which helps in accurate positioning the valve device with respect to the longitudinal orientation;

Figures 17a and 17b describe a valve device according to the present invention, comprising one valve assembly mounted on a stent and an additional portion with a stent only. This allows placing the device in a way that coronaries are not blocked, longitudinal positioning thus becomes less sensitive and the extra stent decreases the risk of device migration within the vasculature;

Figures 18a and 18b demonstrate a crimping device according to the present invention, which can crimp a valve device in the operating theater as part of the implantation procedure;

Figures 19a to 19c depict a crimping machine according to the present invention, similar to the one described in figure 18 with a different mechanical method;

Figures 20a and 20b demonstrate a valve according to the present invention, made of a tube mounted on a stent. During systole the tube is fully open and during diastole the tube collapses according to the mounting geometry providing tight sealing;

Figure 21 depicts a stent structure according to the present invention, with built-in mounting portions of constant length, which allow valve mounting;

Figure 22 depicts yet another preferred embodiment a valve assembly in accordance with the present invention, having dilated supports;

Figures 23a to 23e depict stages in a method of manufacturing an implantable prosthetic valve in accordance with another preferred embodiment of the present invention;

Figures 24a to 24c illustrate a support frame of an implantable prosthetic valve having means for mounting valve leaflets in accordance with a preferred embodiment of the present invention that can form a tricuspid valve. Figure 24a depicts an isometric view of the frame, and Figure 24b depicts a cross-sectional view of the means for mounting a valve leaflet in details, provided with a valve leaflet. Figure 24c depicts further details of attachment means for the attachment method;

Figures 25a to 25d illustrate an implantable prosthetic valve in accordance with another preferred embodiment of the present invention. Figures 25a and 25b depict an isometric view and an upper view of the valve assembly, respectively, and Figures 25c and 25d illustrate upper views of two optional constructions for the means for mounting leaflets;

Figures 26a to 26c illustrate a tricuspid valve in accordance with yet another preferred embodiment of the present invention, provided with a self-expandable frame. Figure 26a is the valve in its fully expanded diameter, Figure 26b is a tapered tool which assists in inserting the valve into an introducing tube, and Figure 26c shows the valve assembly inside a restriction tube, ready to be inserted into a introducing sheath;

Figure 27 illustrates an isometric view of an implantable prosthetic valve in accordance with another preferred embodiment of the present invention having hooks designated to anchor the valve assembly to body ducts;

Figure 28 illustrates a partial view of an implantable prosthetic valve in accordance with yet another preferred embodiment of the present invention. The commissural attachment is showed in details;

Figures 29a and 29b illustrate an isometric view and an upper cross-sectional view, respectively, of an attachment assembly of a valve's frame to leaflets in accordance with a preferred embodiment of the present invention;

Figures 30a to 30c illustrate an isometric view, a cross-sectional view and a flattened view, respectively, of an attachment assembly of a valves frame to leaflets in accordance with another preferred embodiment of the present invention. Figure 30c is a side view showing two pieces of pericardium before the attachment to the frame;

Figures 31a and 31b illustrate an exploded view and an isometric view, respectively, of a commissural attachment in accordance with a preferred embodiment of the present invention depicting the attachment technique;

Figures 32a and 32b illustrate an isometric view of an attachment between leaflets and the frame in accordance with yet another preferred embodiment of the present invention;

Figures 33a to 33d illustrate different views and portions of an attachment between a pericardium and a frame in accordance with yet another preferred embodiment of the present invention, demonstrating another method of attachment in accordance with the preferred embodiment;

Figures 34a to 34c illustrate an isometric view of an attachment between a pericardium and a valve in accordance with yet another preferred embodiment of the present invention demonstrating another method of attachment. In Figures 34b and 34c, a deployed portion and the folded portion, respectively, are shown;

Figures 35a to 35d illustrate an isometric and cross-sectional upper views, respectively, of attachment techniques between a pericardium leaflet and a valve's frame in accordance with another preferred embodiment of the present invention;

Figures 36a and 36b illustrate an isometric view of a commissural assembly in accordance with a preferred embodiment of the present invention demonstrating a method of forming one;

Figures 37a to 37c illustrates a commissural assembly in accordance with another preferred embodiment of the present invention, where the connecting bar functions as a



flexible support and has integral attachment means to the frame. Figure 37b is an isometric view of the connecting bar;

Figures 38a to 38g illustrate isometric views of flexible commissural supports and the method of attaching them to a pericardium and a frame and valve in accordance with preferred embodiments of the present invention;

Figures 39a to 39b illustrate an isometric view of a commissural attachment in accordance with yet another preferred embodiment of the present invention, demonstrating the attachment of the pericardium to the support by means of a shaped compressing member;

Figures 40a to 40c illustrate an isometric view of a bicuspid valve mounted on a frame in accordance with yet another preferred embodiment of the present invention. Figures 40b and 40c depicts a cross-sectional side view and an isometric view, respectively, of the pericardium that is sutured to a PET tube in the form of pockets;

Figures 41a to 41d illustrate isometric views of an implantable prosthesis tricuspid valve in accordance with yet another preferred embodiment of the present invention;

Figures 42a and 42b illustrate an isometric view of an implantable prosthetic valve in accordance with yet another preferred embodiment of the present invention, having a different commissural attachment. Figure 42b depicts the attachment in details;

Figures 43a and 43b illustrate an isometric view of an implantable prosthetic valve in accordance with yet another preferred embodiment of the present invention. Figure 43a depicts the commissure that are pre-sutured in a tapered shape;

Figures 44a to 44c illustrate an isometric view of an implantable prosthetic valve in accordance with yet another preferred embodiment of the present invention, with additional pieces of PET used for sealing and protecting the pericardium;

Figures 45a to 45d illustrate an isometric view of an implantable prosthetic valve in accordance with yet another preferred embodiment of the present invention, having leaflets sutured to a pre-shaped PET tube and optional leaflet-tube attachments in details;

Figures 46a and 46b illustrate an exploded view and an upper cross-sectional view of an implantable prosthetic valve assembly in accordance with yet another preferred embodiment of the present invention;

Figures 47a to 47c illustrate a partial cross-sectional side view of an inflating balloon in accordance with a preferred embodiment of the present invention. The balloon is a part of an implantable prosthetic valve delivery system. Figures 47b and 47c are cross sectional upper views in the inflated and deflated positions, respectively; and

Figures 48a and 48b illustrate a partial cross-sectional side view and an upper cross-sectional view of an inflating balloon in accordance with another preferred embodiment of the present invention.

#### DETAILED DESCRIPTION OF THE INVENTION

A main aspect of the present invention is the introduction of several novel designs for an implantable prosthetic valve. Another aspect of the present invention is the disclosure of several manufacturing methods for implantable prosthetic valves in accordance with the present invention. A further aspect of the present invention is the provision of novel deployment and positioning techniques suitable for the valve of the present invention.

Basically the implantable prosthetic valve of the present invention comprises a leafed-valve assembly, preferably tricuspid but not limited to tricuspid valves only, consisting of a conduit having an inlet end and an outlet, made of pliant material arranged so as to present collapsible walls at the outlet. The valve assembly is mounted on a support structure such as a stent adapted to be positioned at a target location within the body duct and deploy the valve assembly by the use of deploying means, such as a balloon catheter or similar devices. In embodiments suitable for safe and convenient percutaneous positioning and deployment the annular frame is able to be posed in two positions, a crimped position where the conduit passage cross-section presented is small so as to permit advancing the device towards its target location, and a deployed position where the frame is radial extended by forces exerted from within (by deploying means) so

as to provide support against the body duct wall, secure the valve in position and open itself so as to allow flow through the conduit.

The valve assembly can be made from biological matter, such as a natural tissue, pericardial tissue or other biological tissue. Alternatively, the valve assembly may be made from biocompatible polymers or similar materials. Homograph biological valves need occasional replacement (usually within 5 to 14 years), and this is a consideration the surgeon must take into account when selecting the proper valve implant according to the patient type. Mechanical valves, which have better durability qualities, carry the associated risk of long-term anticoagulation treatment.

The frame can be made from shape memory alloys such as nickel titanium (nickel titanium shape memory alloys, or NiTi, as marketed, for example, under the brand name Nitinol), or other biocompatible metals. The percutaneously implantable embodiment of the implantable valve of the present invention has to be suitable for crimping into a narrow configuration for positioning and expandable to a wider, deployed configuration so as to anchor in position in the desired target location.

The support stent is preferably annular, but may be provided in other shapes too, depending on the cross-section shape of the desired target location passage.

Manufacturing of the implantable prosthetic valve of the present invention can be done in various methods, by using pericardium or, for example, by using artificial materials made by dipping, injection, electrospinning, rotation, ironing, or pressing.

The attachment of the valve assembly to the support stent can be accomplished in several ways, such as by sewing it to several anchoring points on the support frame or stent, or riveting it, pinning it, adhering it, or welding it, to provide a valve assembly that is cast or molded over the support frame or stent, or use any other suitable way of attachment.

To prevent leakage from the inlet it is optionally possible to roll up some slack wall of the inlet over the edge of the frame so as to present rolled-up sleeve-like portion at the inlet.

Furthermore, floating supports may be added to enhance the stability of the device and prevent it from turning inside out.

An important aspect of certain embodiments of the present invention is the provision of rigid support beams incorporated with the support stent that retains its longitudinal dimension while the entire support stent may be longitudinally or laterally extended.

The aforementioned embodiments as well as other embodiments, manufacturing methods, different designs and different types of devices are discussed and explained below with reference to the accompanying drawings. Note that the drawings are only given for the purpose of understanding the present invention and presenting some preferred embodiments of the present invention, but this does in no way limit the scope of the present invention as defined in the appended claims.

Reference is now made to Figure 1, which illustrates a general tricuspid implantable prosthetic valve 20 in accordance with a preferred embodiment of the present invention, suitable for percutaneous deployment using an expandable stent or similar deploying means, shown in its deployed position. A valve assembly 28 comprises a conduit having an inlet 24 and an outlet 26, the outlet walls consisting of collapsible pliant material 29 that is arranged to collapse in a tricuspid arrangement. The valve assembly 28 is attached to an annular support stent 22, the one in this figure being a net-like frame designed to be adapted to crimp evenly so as to present a narrow configuration and be radially deployable so as to extend to occupy the passage at the target location for implantation in a body duct. Support beams 23 are provided on annular support stent 22 to provide anchorage to valve assembly 28. Support beams 23 are optionally provided with bores 25 to allow stitching of valve assembly 28 to support beams 23 by thread, wires, or other attachment means.

In the embodiment shown in Figure 1, a cuff portion 21 of the valve assembly 28 is wrapped around support stent 22 at inlet 24 to enhance the stability. Preferably cuff portion 21 of valve material 28 is attached to support beams 23.

Note that the entire valve structure is adapted to be radially crimped and radially expanded, and this lends to provide ease of navigation through narrow passages in the vasculature during positioning of the device and adequate deployment on the final location. This is made possible by the provision of a collapsible support stent structure. However, the support beams remain at all times constant at their length and thus are suitable for serving as the pliable valve assembly's anchorage. The valve assembly is attached to the support stent at the support beams, and due to their constant length there is no need for slack material as the attachment points (25) remain at constant distances regardless of the position of the valve device (crimped or deployed). This is an important feature for this means that the manufacturer of the valve device can make sure the valve assembly is secured and fastened to the support stent at all times. In prior art implantable valve devices the entire support structure changes its dimensions from its initial first crimped position and final deployed position, and this means that in the attachment of the valve assembly to the support structure one must take into consideration these dimension changes and leave slack material so that upon deployment of the device the valve assembly does not tear or deform. In the valve device of the present invention there is no relative movement between the valve assembly and the support beams (along the longitudinal central axis of the device). As a result, the valve device of the present invention acquires greater durability and is capable of withstanding the harsh conditions prevailing within the vasculature and especially the millions of cycles of stress applied by the blood pressure.

The fixed attachment of the valve assembly to the support stent in the valve device of the present invention results in greater stability, enhanced safety, better sealing and consequently longer lifespan. The novel design of the valve device of the present invention leads to longitudinal strength and rigidity whereas its collapsible support structure results in radial flexibility.

Figure 2 depicts an implantable valve 30 mounted on a deployable stent 32. The valve assembly 34 is attached to the deployable support stent 32 (dotted lines) along three substantially equidistant and substantially parallel support beams 40 of constant length,

which are part of stent 32. The attachment of valve assembly 34 to stent 32 is facilitated by the support beams 40 to which valve assembly 34 is stitched with thread or fiber 46 (through bores 42 of support beams 40). Outlet leafs 38, which are a slack portion of the valve assembly, dangle inwardly, and the whole device is carried by an inflatable balloon 48, which serves as the deploying device. A portion of the valve assembly 34 at an inlet zone 45 is optionally rolled over support stent 32 at the inlet, making up a rolled sleeve, which enhances the sealing of the device at the valve inlet.

Figure 3 demonstrates an implantable valve mounted to a stent 50 with an inflatable balloon 52, in a crimped position. The support stent 50 is initially crimped about the balloon 52 so that it presents a narrow cross-section and is thus suitable for percutaneous catheterization and deployment.

Figure 4 depicts an implantable valve deployment in a natural aortic valve position. The implantable valve is advanced while mounted over the balloon 52 until it reaches the desired target location 54 in a body duct, for example, aorta 56. The balloon is inflated and the support stent 50 expands radially to take up its position.

Figure 5 demonstrates the manufacture of a polyurethane valve in a dipping technique. A dipping mandrel 60 is provided with a tubular portion 62 with surfaces 64 that correspond to the collapsible valve leaflets to be manufactured. Mandrel 60 is dipped into a dissolved polyurethane bath 66 and is coated with a polyurethane coating in the desired form of the valve. Then, after the polyurethane coating has hardened sufficiently, the completed valve is removed from mandrel 60.

Figures 6a to 6e illustrate manufacturing an implantable valve by forging. A suitable tubularly shaped material 74 is placed tightly on a tubular portion 68 of mandrel 67, covering the cusp portion 69. Flexible inserts 76 are pressed to mandrel 67, forging the tubular material to mandrel shape 80. A tapered ring 70 holds the flexible inserts in place as the whole mold is placed in a hot oven regulated to a desired temperature, which is lower than the material's melting point. Figure 6e illustrates a sectional side view of the mandrel and a cross cut portion of the mold. The mold is made to press inwardly on

the mandrel, which is covered with the valve material. As a result the material takes up the desired shape. The materials used can vary, for example, polyurethane (PU), polyethylene terephthalate (PET), or any other suitable material, which may be formed by heating.

Figures 7a and 7b demonstrate a method of manufacturing a composite valve, which has PU leaflets and PET tubular construction with a crown shape. PU is an excellent fatigue resistant material but is sensitive to tear. The PU is reinforced by the PET crown to allow safe attachment to a stent by means of stitching, riveting, or any other suitable attachment method. A PET crown 86 is placed on a mandrel 87, which is then (turned and) dipped in a container of dissolved PU. The manufactured device is a valve assembly having leaflets 88 composed of pure PU, and thus fatigue resistant, and a main body made of PET with protruding attachment portions 90 suitable for attachment built in the PU.

Figures 8a and 8b demonstrate a method of manufacturing a composite valve, which is based on flexible PU 92 for as the main body of the valve, rigid PU support beams 94 serving for the attachment area, and PET sleeve 96 portions for the valve inlet. The need for a rigid portion for attachment (support beams 94) is explained by the tendency of the flexible, fatigue resistant material to tear as already explained. The advantage of the stiff PU support beams is that they are chemically adhered to the main body, and this improves the overall durability of the valve due to reduction of inner forces and friction in the attachment area specially attachment between two different materials. The valve is dipped in the method mentioned with reference to Figure 5, and the rigid PU support beam 94 is created by way of mold injection, machining or any other suitable way. The rigid PU support beam 94 is placed on the valve and then dipped into the container of dissolved PU. This is done while the valve is positioned on the mandrel (not shown). This method provides the ability to composite several materials into one body and, by that, gain the advantage of the various properties of the materials as they are needed in different areas of the prosthesis.

Figures 9 to 9i demonstrate different methods of attachment between a valve assembly and the support stents. A valve assembly 99 shown in Fig. 9 is incorporated into valve 100 shown in Fig. 9a, where a support stent 102 is attached to valve assembly 99 through support beam 106. A detail is shown in Fig. 9b, where, in cross-section, it can be seen that layer 108 is an optional inner support made of stainless steel or rigid polymeric material, valve assembly 99 comprises a PET layer 105 coated with a PU layer 104, with the outer support beam 106. Connector 107 is a connecting wire made of a strong material, such as stainless steel. Figure 9c illustrates an alternative arrangement for attachment by a rivet 109, and in Figure 9d the attachment is achieved by a suture 110.

Figures 9e to 9g show an attachment method comprising shaped rigid members 116, preferably made from metal, which tightly hold the PU valve material 118 by fitting in between a PU U-shaped nest 120 and are attached to a stent 122 by extruding portions 124 that are provided on U-shaped rigid member 116, which fit the bores 126 of the support beam 128 of the stent 122. Figures 9h and 9i show another attachment method, where rigid support beams in the form of frame construction 132 are provided, and the valve assembly pliant material 135 made of a tubular material is inserted through a gap 137 in the frame. After insertion, a fastening rod 133 is inserted through the pocket formed between the pliant material and the frame and holds the valve in position.

Figure 10 illustrates a dipping mandrel 139 with an extending portion 141, which improves the sealing ability of the valve. Since the valve is attached to a collapsible stent and is itself collapsible, it is difficult to determine the exact shape of the valve after crimping and deploying. It is of major importance that sealing will be achieved. By adding the extension 141 the leaflets are made longer than needed to exactly close the outlet, and therefore when they are in the collapsed state, substantial portions of the leaflets fall on each other creating better sealing.

Figures 11a to 11c illustrate a valve assembly mounted on a support stent 144 with interlaced strengthening wire 146, which improves the force distribution on the valve material and facilitates prolonged durability of the valve. The support is in the form of a



wire, which has a crown shape as the shape of the three cusp valve base 148, it also has the ability to be crimped 150 to a small diameter, together with the stent, valve and balloon, as shown in Fig. 11b. The forces applied to the valve edge 148 while working, are applied to the attachment points, by making the attachment line longer we reduce the force on each attachment point. In this support method the valve is attached by suturing 152 the entire line to the extra support wire 146. This wire can be made of stainless steel, nickel titanium alloy such as nitinol, or polymeric material. The support suture renders the valve assembly default fault lines where the valve material more readily flexes, thus ensuring proper operation of the valve flaps (leaflets). Optionally the valve assembly shown in Figures 11a to 11c can be mounted on a support stent such as the one described herein or similar supporting structures. The strengthening wire is interlaced in the valve assembly at the outlet of the conduit so as to define a fault line about which the collapsible slack portion 154 of the valve assembly may flap.

Figures 12a to 12c depict a valve device provided with a stent 159 and substantially equidistant rigid support beams 160, interlaced or attached to the slack portion of the valve assembly material 161, arranged longitudinally. This design allows the valve leaflets to perform without outer support. The support in standard valves is by tying the upper edge of the cusp to a rigid embodiment, so that it reacts to the load as a suspension bridge. In this new design the prevention of collapsing is achieved similar to an Indian tent, i.e., the rigid supports lean on each other 162 when the valve is closed but do not interfere in opening 164 when the valve is open.

Figures 13a to 13c illustrate the manufacturing of a valve assembly in accordance with another preferred embodiment of the present invention. At first a polyurethane thread line 170 is fed from a PU supply 172, and coiled around a cylindrical drum 174 to form coil 176. Then, drum 174 with coil 176 is dipped in a PU bath 177, and a second layer 178 of the PU coats coil 176, making it a stronger construction capable of withstanding tearing forces both laterally and in other directions. Incorporating two different types of materials - such as PU and PET - may render greater durability and

endurance to the valve assembly. This material is an alternative material to be used in the forging method shown in Figure 6.

Figures 14 to 14c demonstrate the incorporation of heavy metal markers on the stent, which markers allow observation and thereby adjustment of orientation while placing the device in the required location. Heavy metals are radiopaque, that is, they are conspicuous on an angioscopic image, which is a two-dimensional image. Since the coronary artery ostia 237 and 238 are located near the typical valve deployment location and must stay open, it is extremely important to make sure that the deployed valve assembly is not blocking a coronary ostium. In some cases the stent is lower than the ostium and in those cases it will stay open, but in some cases as shown in these figures it is necessary to make sure that the stent portion 239 that is connecting the valve supports 235 is opposite the coronary ostia, and in that way the blood supply is preserved through the stent struts. Two heavy metal markers 232 are attached at the outlet side, one marker 230 at the inlet side. It is possible to adjust the angioscopic view to the plane of the left coronary as shown in Figure 14b and anatomically locate the other accordingly. If the two upper markers 232 are placed in the radiographic two dimensional image, one on top of the other, and the low marker 230 on the opposite side, we make sure that the coronaries are open to blood flow as seen in Figure 14c. Gold, platinum, iridium or tantalum are all biocompatible materials suitable for the markers described above.

Figures 15a to 15c illustrate a valve with a portion of radio-opaque material 267 such as a thread of gold at the sealing edge. When a valve is implanted, it is very important to have clear indications of how the valve is functioning *in vivo*; pressure measurements, flow visualization, and doppler measurements are utilized. It is also possible to examine the valve by ultrasound methods, however, observing the opening and closing of the valve cusps on a monitor. Fig. 15b is an angiographic image 268 of the open valve, while image 169 in Figure 15c is the closed position as seen on the angiogram.

Figures 16a to 16c illustrate a procedure, which helps in placing the device in the longitudinal position. It is very important to place the device in the correct longitudinal

position, for if it is too deep in the left ventricle it may interfere with the mitral valve function by improper closing or function of the valve. If it is positioned too high it may migrate, it may leak via the sinus cavities, which are located around it, and/or it may block the coronaries. It is a necessary task to position the valve prosthesis in a narrow target location. In Figure 14 a method of lateral orientation placement is shown, and Figures 16a to 16c illustrate a longitudinal positioning. The valve device (the valve assembly and the support stent) is placed on an inflatable balloon catheter, comprising double independently inflatable chambers 303, 305, and is inserted into the left ventricle 302 in the crimped position and guided over a guiding stylet or guide wire 300. The balloon, which is larger than the annulus diameter when inflated, is inflated in the left ventricle 302, and then the whole device is pulled slightly backwards. The balloon is supported on the inner part of the annulus 303, allowing positioning of the device in the exact desired position. In addition, it temporarily blocks the blood flow, and that improves the ability to hold the device in place while inflating it. The next step is inflating the second balloon 305, which deploys the valve device in the desired location.

The method for deploying an implantable prosthetic valve device at the natural aortic valve position at the entrance to the left ventricle of a myocardium of a patient, as depicted in Figures 16a, 16b and 16c, comprises the steps of:

- (a) providing a balloon catheter having a proximal end and a distal end, having a first and second independently inflatable portions, the first inflatable portion located at the distal end of the catheter and the second inflatable portion adjacently behind the first inflatable portion;
- (b) providing a guiding tool for guiding the balloon catheter in the vasculature of the patient;
- (c) providing a deployable implantable valve prosthesis device adapted to be mounted on the second inflatable portion of the balloon catheter
- (d) guiding the balloon catheter through the patient's aorta using the guiding tool, the valve device mounted over the second inflatable portion of the balloon catheter

until the first inflatable portion of the balloon catheter is inserted into the left ventricle, whereas the second inflatable portion of the balloon catheter is positioned at the natural aortic valve position;

(e) inflating the first inflatable portion of the balloon catheter so as to substantially block blood flow through the natural aortic valve and anchor the distal end of the balloon catheter in position;

(f) inflating the second inflatable portion of the balloon catheter so as to deploy the implantable prosthetic valve device in position at the natural aortic valve position;

(g) deflating the first and second inflatable portions of the balloon catheter;  
and

(h) retracting the balloon catheter and removing it from the patient's body.

Figure 17 describes a positioning of a valve device 310 using an additional deployable stent 320. There are several problems that may be encountered while deploying the stent and valve in the aortic valve location: blockage of coronaries may occur that is dangerous if the diameter of the stent is similar to that of the coronaries aortic root 309. Secondly, migration of the whole device may also occur, which is a dangerous possibility, and there is the problematic challenge of exact positioning of the valve device that is very difficult to accomplish, as already explained. The newly special designed device with a double diameter inflatable balloon and double stent design allows placement of the device in a way that coronaries will not be blocked because of a safe difference that is kept between the diameters, longitudinal placing is less sensitive because of the small diameter which ensures prevents over expansion of the valved prosthesis. The distal stent 320, which contains no valve, is expanded into the ascending aorta, while the proximal stent 310 is placed simultaneously in the annular position. This placement method is less challenging due to the smaller diameter of the proximal stent 310 which ensures that the mitral valve is not deformed by over-expansion as the

dimensions are preserved, and the additional stent decreases the risk of device migration. It is safer to over dilate in the aorta, which is not true for the annulus.

The method for deploying an implantable prosthetic valve device at the natural aortic valve position at the entrance to the left ventricle of a myocardium of a patient, as depicted in Figures 17a and 17b, comprises the steps of:

(a) providing a balloon catheter having a proximal end and a distal end, having a first and second independently inflatable portions, the first inflatable portion located at the distal end of the catheter and the second inflatable portion adjacently behind the first inflatable portion;

(b) providing a guiding tool for guiding the balloon catheter in the vasculature of the patient;

(c) providing a deployable implantable valve prosthesis device adapted to be mounted on the first inflatable portion of the balloon catheter, and a deployable annular stent device adapted to be mounted over the second inflatable portion of the balloon catheter, the deployable implantable valve prosthesis device and the deployable annular stent kept at a predetermined distant apart;

(d) guiding the balloon catheter through the patient's aorta using the guiding tool, the valve device mounted over the first inflatable portion of the balloon catheter and the deployable annular stent mounted over the second inflatable portion of the balloon catheter, until the first inflatable portion of the balloon catheter is positioned at the natural aortic valve position;

(e) inflating the second inflatable portion of the balloon catheter so that the deployable stent device is deployed within the aorta thus anchoring the deployable annular stent and the coupled valve device in position;

(f) inflating the first inflatable portion of the balloon catheter so as to deploy the implantable prosthetic valve device in position at the natural aortic valve position;

- (g) deflating the first and second inflatable portions of the balloon catheter;
- and
- (h) retracting the balloon catheter and removing it from the patient's body.

Figures 18a and 18b illustrate an accessory crimping device that is adapted to crimp a valve device in the operating theater as part of the implantation procedure. The crimping device 330 comprises several adjustable plates that resemble a typical SLR camera variable restrictor. It is comprised of simultaneously movable plates 332 each provided with a blade 334, that are equally dispersed in a radial symmetry but each plate moves along a line passing off an opening in the center, all plates equidistant from that center opening 336. Initially (see Figure 18a) the plates are drawn apart providing a large enough opening for the implantable valve to be positioned within that opening. When the plates are drawn towards the center (see Figure 18b), the opening 336 reduces in size but still retains the annular shape, and this facilitates the crimping of the valve frame to a small dimension suitable for percutaneous positioning.

Figures 19a depicts a crimping method for the support stent of the valve prosthesis device of the present invention, whereby stent 340 is crimped, that is, compressed or curled. In Figure 19b a crimping device 343 is shown, comprising a body having an annular void in which an expanded stent is positioned. Lever 346 is connected to the end 347 of the stent and as the lever is pulled the stent is curled or compressed about axle 345 into a compressed position 349 (Figure 19c).

Figures 20a and 20b depict a valve made of a simple tube mounted to a stent 352. During systole period the tube is fully open and during diastole period the tube collapses according to the mounting geometry 357 and achieves sealing.

Figure 21 describes a newly designed support stent 360 in its open position. Three of the longitudinal struts 362 are full and thick and always stay with their original constant size, serving as anchoring support. Each of these struts 362 is provided with a plurality of bores 364, which are later used for mounting the valve assembly (not shown) and tying it to stent 360. Between struts 362 a web-like construction is provided, which

is capable of being crimped to a narrow state and capable of being deployed again to a wider state.

Figure 22 illustrates another preferred embodiment of an implantable prosthetic valve according to the present invention. It comprises a metal tube 370, having three portions with a thicker wall 371 than in the rest of the tube 370, these areas form the longitudinal columns 372 in the construction, after the tube is cut to its final form. The advantage of such a construction is in its superior bending strength, in specific required portions of the construction, with minimal interference to the crimped volume of the whole construction.

Figure 23a to 23c depict a new method of manufacturing an artificial or biological crimpable valve device. A piece of fabric material 370 (Fig. 23a), is dipped in PU to create a portion which is later formed into valve leaflets 371 (Fig. 23b). This composite material 371 is then attached to an additional piece of fabric such as PET 372 by means of stitching, suturing or other attaching technique 373 (Fig. 23c). The resulting fabric 375 is cut along stitching line 373 leaving enough material to later suture the valve assembly to the support construction. It is then formed to a tubular shape and stitched 374 (Fig. 23d). The tubular valve is then attached to a support construction 380 by suturing the bottom part around the valve 379 tightly to prevent leakage, and around the cut fabric line 376 (Fig. 23e). This open wall structure 378 allows blood flow to the coronary arteries. The valve is later placed with the coronary artery between the support columns 385. Additional variations of this can be made by replacing the composite material 371/370 with a biological patch such as a suitable pericardium patch. In some cases it is possible to make the same valve without cutting the fabric 372 with the shaped cut 376, and by that create a valve with an outer tubular shape. The embodiment of Figs. 23a to 23c is easy to manufacture as it is generally flat throughout most of the production process and only at the final stage of mounting on the support stent is it given a three-dimensional form.

Reference is now made to Figure 24a illustrating a frame of an implantable prosthetic valve having means for mounting valve leaflets in accordance with a preferred

embodiment of the present invention that can form a tricuspid valve. Figure 24a depicts an isometric view of the frame and Figure 24b depicts a cross sectional view of the means for mounting valve leaflets 430 in detail. A frame 420, which is suitable for crimping and expanding, has three support beams 422 for mounting leaflets positioned substantially symmetrically about the circumference of the frame. Frame 420 is shown in Figure 24a in its deployed state. Support beam 422 has a “U” shaped lateral cross section, or profile (shown clearly in Figure 24b) that is designed to attach to a commissure of the valve structure. The “U” shape can be produced by extrusion, wire cutting or by welding the “U” profile to the frame’s struts 421 at junction points 424. Support beam 422 is provided with a series of bores 425 positioned along its back wall. Bores 425 are designated for stitching the valve assembly by threads, wires, or other attaching means.

Figure 24b is a detailed cross-sectional view of one of the support beam 422. Two pericardial leaflets 430 are inserted through a U-shaped, or forked holder 428 that compresses and restricts the leaflets in the U-shaped profile. Leaflets 430 are folded to both sides of the support beam 422. When holder 428 is compressed toward the support beam 422, leaflets 430 are caught in-between holder 428 and support beam 422 so that the leaflets are kept in place. Figure 24c is an exploded view of the holder, bar 426 has a series of bores compatible for attachment to the frames support beam 422, attachment being achieved by suture 423 or any other attachment means. This attachment method allows attaching the leaflets to the frame without puncturing it with sutures and needles. It is also important that the leaflets are firmly held in place by the holder 428 so that it has no relative movement in respect to the rigid frame; hence avoiding wear due to movements. Leaflets that are made from pericardium are known to better withstand inner movements and stresses and less to wear by movement against rigid, hard or sharp bodies.

It is noted again that the entire valve structure is adapted to be radially crimped and radially expanded. This feature imparts the valve with the ability and ease to navigate through narrow passages in the vasculature during positioning of the device. After final positioning of the valve, the valve is deployed. This is made possible by the provision of a collapsible support frame structure. However, the length of the attaching means (the



height of the valve) remains at all times constant; thus suitable for serving as the pliable valve assembly's anchorage. The leaflets are attached to the support frame at the attaching means, and due to their constant length there is no need for slack material as these attachment points that remain at constant distances regardless of the position of the valve assembly (crimped or deployed). This is an important feature for this means that the manufacturer of the valve device can make sure the valve assembly is secured and fastened to the support frame at all times. In prior art implantable valve devices, the entire support structure changes its dimensions from its initial first crimped position to final deployed position and this means that in the attachment of the valve leaflets to the support structure one must take into consideration these dimension changes and leave slack material so that upon deployment of the device, the valve assembly does not tear or deform. In the valve device of the present invention there is no relative movement between the valve leaflets and the support beams (along the longitudinal central axis of the device). As a result, the valve device of the present invention acquires greater durability and is capable of withstanding the harsh conditions prevailing within the vasculature and especially the millions of cycles of stress applied by the blood pressure.

The fixed attachment of the valve leaflets to the support frame in the valve assembly device of the present invention renders it greater stability, enhanced safety, better sealing and consequently longer lifespan. The novel design of the valve device of the present invention renders it longitudinal strength and rigidity whereas its collapsible support structure renders it radial flexibility.

Figures 25a to 25d illustrate an implantable prosthetic valve in accordance with another preferred embodiment of the present invention. Figures 25a and 25b depict an isometric view and an upper view of the valve assembly, respectively and Figures 25c and 25d illustrate upper views of two optional constructions for the means for mounting leaflets. Pericardial leaflets 430 are mounted on a deployable support frame 432. The frame is preferably made of three segments that form a circular support frame when assembled (Figure 25b). Pericardial leaflets 430 are attached to deployable support frame 432 along three substantially equidistant and substantially parallel beams 440, which are

integral parts of support frame 432. Leaflets 430 are attached to support frame 32 at support beams 440 by suturing 446 leaflets 446 to support beams 440 through bores 442 in beams. The frame segments that are preferably made from stainless steel are pre-shaped 432 and can be formed in different ways. Figure 25c illustrates support frame segments 432a having beams 435a pointing inwardly. Figure 25d illustrates support frame segments 432b having beams 435b that are outwardly pointing. The advantages of this technique are the possibility to manufacture the frame segments from sheets (as opposed to tube) and the ease of assembly of the frame segments with the pericardial leaflets.

Figures 26a to 26c illustrate a tricuspid valve in accordance with yet another preferred embodiment of the present invention, provided with a self-expandable frame. Figure 26a is an isometric view of an implantable prosthetic valve 430 mounted on a self-expandable frame 445. Implantable prosthetic valve 430 comprised of three valve leaflets is mounted on self-expandable frame 445 so that each leaflet extends along an equidistant portion of the frame and is sutured at both opposite sides to substantially equidistant and substantially parallel beams 440. By using a tapered tube 448 the whole assembly is crimped into a restriction tube 449. Figure 26b shows the crimped valve assembly 447 in its final crimped diameter ready for insertion to the body. After insertion into the desired location in the body the valve is released from the restriction tube and as it is made of self expandable material (like a shape-memory alloy), it expands back to the original diameter and is anchored in place. In order to reduce the diameter of the device from its fully expanded diameter to its crimped diameter a special tapered tube is used, shown in Figure 26c.

Figure 27 illustrates an isometric view of an implantable prosthetic valve in accordance with another preferred embodiment of the present invention having hooks designated to anchor the valve assembly to body ducts. An implantable prosthetic valve 450 is placed in a natural aortic valve position 452. Implantable prosthetic valve 450 comprises preferably three leaflets 430 mounted on a metallic support frame 455. The lower part of support frame 455 is provided with attachment means, preferably with

hooks 453. Hooks 453 assures that the valve assembly stays in place after deployment, and cannot migrate to another position.

Figure 28 illustrates a partial view of an implantable prosthetic valve in accordance with yet another preferred embodiment of the present invention. The commissural attachment is shown in details. This figure demonstrates an attachment technique that is used in order to attach pericardium leaflet 430 to a metallic frame 420. A longitudinal bar 456 having a narrow slit 457 is used as the commissural attachment so that extensions 463 of pericardium leaflet 430 are tightly inserted through slit 457. Pericardium extensions 463 that are extended beyond slit 457 are wrapped about a rigid bar 458 that acts as an anchoring means. Every two extensions originating from two sides of slit 457 are sutured to each other by a suture 459 at the side of rigid bar 458 opposite the slit. An additional suture 462 attaches the bottom circumference of support frame 420 to leaflet 420 in order to obtain sealing. The advantages of the described attachment are that no sutures or suture holes are applied in the leaflet working area, there are no concentrated stress points similar to stress point caused by suturing, and the force distribution is along the longitudinal bar 456. The narrow passage that is maintained through slit 457 forces the leaflets to be static in respect to the support so as to reduce abrasion.

The embodiments that will be shown herein after are optional configurations of attachment between the leaflets and the support frame.

Figures 29a and 29b illustrate an isometric view and an upper cross sectional view, respectively, of an attachment assembly of a valve's frame to leaflets in accordance with a preferred embodiment of the present invention. The attachment is similar in principle to the attachment shown in Figure 28, however, longitudinal bar 456 is further provided with an additional pole 465 that is attached to longitudinal bar 456 so as to establish an integral part. Pole 465 is rounded so as to make sure the leaflets will not be abraded or cut by sharp corners. In the cross sectional view shown in Figure 29b, adjacent leaflets 460 can be seen compressed together and the main protection goal is clearly shown.

Figures 30a to 30c illustrate an isometric view, a cross-sectional view and a flattened view, respectively, of an attachment assembly of a valves frame to leaflets in accordance with another preferred embodiment of the present invention. Using the method demonstrated in Figures 30a to 30c, the pericardial leaflets are pre-cut to the desired shape 430 and are provided with longitudinal bars 470 that are sutured to the leaflets creating a longitudinal clamping effect (Figure 30c). This allows distribution of forces along the whole length of the attachment means as opposed to concentrating the stresses in suture holes. In Figures 30a and 30b, an additional rigid portion 458 is added, creating a round ending, which prevents the leaflets from being bent drastically at the attachment point to portions of the frame 420. The attachment to frame 420 is performed using sutures 459.

Figures 31a and 31b illustrate an exploded view and an isometric view, respectively, of a commissural attachment in accordance with a preferred embodiment of the present invention depicting the attachment technique. A method of assembling pericardial leaflets 430 to a frame 420 is demonstrated. A rigid bar 476 provided with integral protrusions 478 is inserted through bores 479 that are pre-cut in pericardial leaflets 430. Integral protrusions 478 pass through a sheet of preferably PET (braided polyester) fabric 475, and finally through bores 442 that are provided in longitudinal bar 440 (the attachment means) of frame 420. After the assembling of the parts, as shown in Figure 31b, the parts are tightly assembled and bar protrusions 478 are attached to bar 440 by welding, riveting or any other technique. The PET sheet 475 is folded and sutured tightly around bar 476 using suture 472.

Figures 32a to 32c illustrate an isometric view of an attachment between leaflets and the frame in accordance with yet another preferred embodiment of the present invention. An optional method of attachment is demonstrated, in which a pericardium leaflet 430 and bars 480 are sutured in area far as possible from the working area of the leaflets. The pericardium is first sutured using a suture 484 to bar 480 as seen in Figure 32b, and then folded and compressed. In order to firmly hold the pericardial leaflets in place between bars 480, an integral connecting member 482 connects the two bars,

allowing the bent portions of the bars to be in parallel position, with the leaflets caught in between. Then, an additional suture 483 connects the bottom side of the bar to the leaflets so that while the valve is working, the leaflets do not bear high stresses.

Figures 33a to 33d illustrate different views of portions of an attachment between a pericardium and a frame in accordance with yet another preferred embodiment of the present invention, demonstrating another method of attachment in accordance with the preferred embodiment. A connecting member 490 (shown in a deployed position in Figure 33d) is used to connect two pericardial leaflets 492 at the line of the commissure. After being connected between them, pericardial leaflets 492 are being connected to frame bar 480. Here again, the principal of compressing the leaflets between two bent portions bars 491 of connecting member 490 and tightening them using suture 484 without punctures in the working areas of the pericardium is applied. However, connecting member 490 is provided with a portion 493 that is positioned perpendicular to the two bent portions bars 491 that holds the two leaflets together. Portion 493 is the connecting member to frame's bar 480. In Figure 33a, the junction point 495 between the portions of connecting member 491 is placed at the upper part (outlet) of the frame so as to achieve a rigid connection to the frame. In Figure 33b, junction point 495 is placed at the bottom part (inlet) of the frame so that the junction point also functions as a spring. Comprehensive explanation of the benefits of springs in commissures is discussed and shown in respect with Figures 37 to 39.

Figures 34a to 34c illustrate an isometric view of an attachment between a pericardium and a valve in accordance with yet another preferred embodiment of the present invention demonstrating another method of attachment. In Figures 34b and 34c, a deployed portion and the folded portion, respectively, are shown. An optional design for the attachment between the frame and the leaflets is depicted. A connecting member 480 (shown clearly in Figure 34b) is being produced into a flat configuration using laser-cutting. Connecting member 480, which is a part of the frame's attachment means, is bent and then is ready for assembly with the leaflets. Connecting member 480 comprises the main body as well as a connection bar 497 and a flexible element 498 allowing

flexibility to the commissural. Leaflets 430 are threaded through corresponding holes 481 in the structured connecting member 480 and are sutured using a suture 482.

Reference is now made to Figures 35a, 35b, and 35c illustrating isometric and cross-sectional upper views, respectively, of attachment techniques between a pericardium leaflet and a valve's frame in accordance with other preferred embodiments of the present invention. Figures 35b and 35c depict different techniques of commissural attachments: in Figure 35b two pieces of pericardial leaflets 500 are wrapped around a metallic member 505 that is connected to a frame 501. Rigid members 503 are positioned from both sides of metallic member 505 and then tightened together and connected by a suture 502. All metallic pieces are wrapped by PET fabric 508 in order to avoid direct contact between the metallic pieces and the delicate pericardial leaflets. The advantage of this structure is that after tightening the suture, the whole commissure becomes static with no relative movement between the portions. This improves the valve assembly's resistance to abrasion. In addition, there are no needle holes or sutures in the working area. Figure 35c depicts a similar structure, however, there is no use of rigid sidebars. After wrapping the metallic member 505 with pericardial leaflets 500, a piece of PET 508 is used for tightening it to a tight bundle. In this case, the suture line 502 is the borderline of the working area so it should be designed so that stresses are in the best possible distribution.

Figures 36a and 36b focus on the connection of the commissural assembly to frame's protrusion 509, which is an integral part of the frame and is the basis for the commissural attachment. This example shows the use of four rigid longitudinal bars 503 connected by a suture 502.

Figures 37a to 37c illustrate a commissural assembly in accordance with another preferred embodiment of the present invention, where the connecting bar functions as a flexible support and has integral attachment means to the frame. Figure 37b is an isometric view of the connecting bar. Connecting bar 520 is flexible and comprises a resilient material shaped in a "U" shape. Connecting bar 520 is a part of commissural assembly 527 shown in Figure 37a. Connecting bar 520 is provided with protruding

elements 521 that are acting as the means of attachment to the frame's bar 480. Protruding elements are designated to be inserted in corresponding bores 442 in bar 480. It is optional to provide rods 527 which are integral parts of the "U" shaped member and replace the suture 526 that connects the pericardium leaflet and the connecting bar together, which is shown in Figure 37a. Figure 37c depict another method of attaching the flexible connecting bar 520 to the frame 480 by means of welding 523. Here the pericardial leaflets 500 are attached to the connecting bar 520 by suture 526 inserted through a PET fabric 508 and two connecting bars 503, which together create a tight bundle.

Figures 38a to 38g illustrate isometric views of flexible commissural supports and the method of attaching them to a pericardium and a frame a valve in accordance with preferred embodiments of the present invention. Figures 38a to 38c demonstrate incorporation of different design options of commissural springs. The main purpose of a commissural spring is to reduce the impact applied to the pericardial leaflets when the valves leaflets are closed. If the structure is of a rigid nature, high stress will be applied each time the valve closes. If a spring is added to the structure, the spring will bear the highest portion of the impact; thus reducing the stress applied to the leaflets during the time the valve is closed. In Figure 38a, a simple stainless steel spring 530 is connected to frame's bar 480 by threading a portion of the spring into slots 538 as shown in more detail in Figures 38e and 38f. In Figure 38b, there is a similar spring 530 with leaflets 500 connected to it by one of the attachment methods, the commissural support itself 530 is connected to the frames bar 480 by spot welding, laser welding or other attachment means. Figure 38c depicts a similar spring 534 having an additional spiral. The purpose of such a spiral is to reduce stress in the spring and to allow the fatigue requirements, which in the case of heart valves are of at least 200 million cycles.

Figure 38d illustrates an isometric view of a flexible commissural support in accordance with yet another preferred embodiment of the present invention, demonstrating the attachment of the pericardium to the support. Figures 38e to 38g are the details of the attachment to the frame. A commissural spring of a different design 539

comprises a stainless steel wire of a small diameter in respect with the springs described in Figures 38a to 38c. One advantage of this structure is the distribution of stresses in the spring and the ability to form a structure, which can be crimped to a small diameter. Another advantage in this structure is that there are no open edges of the spring, which can be dangerous when operated; the open edges are protected in the frame's bar as shown in Figures 38e to 38g, which show possible attachment methods of the spring to the frame. In Figure 38e, a frame's flat bar 480 cut in shape with slots for crimping the spring 536. Figure 38f shows pre-bending of the slots 527 and Figure 38g shows the spring legs 539 assembled firmly into the slots 538.

Figure 39a illustrates a technique of commissural assembly using a shaped compressing member 511. The compression member 511 holds pericardial leaflets 500 firmly while pressing it in the pivot points 513. A radial edge 514 is made in order to protect the pericardium from abrasion. The whole assembly is held tightly inside the compressing member 516. The commissural assembly is connected to the frame by protrusion member 518, which fit bores in the frames bar 480. Figure 39b is an isometric view of the same detail.

Figures 40a to 40c illustrate an isometric view of a bicuspid valve mounted on a frame in accordance with yet another preferred embodiment of the present invention. Figures 40b and 40c depict a cross-sectional side view and an isometric view, respectively, of the pericardium that is sutured to a PET tube in the form of pockets. The valve assembly (in this case bicuspid) comprises a crimpable frame 540, two pericardial leaflets 545, a PET skirt 543 and a connecting suture 547. The focus in this drawing is on the pocket shape of the pericardium leaflet shown best in Figures 40b and 40c. One of the main goals in valve design, in general, is to distribute the stresses in a homogenous way in the pericardium material and the attachment areas. The design of the pericardium leaflet as a pocket assists in distributing the stresses along suture line 547; pericardium leaflet 545 is sutured to PET skirt 543 along connecting suture 547. PET skirt 543 is sutured to the circumference of crimpable frame 540 at the bottom side 549 and at the top 542 using one of the commissural attachments that are described herein before regarding



other embodiments. When hydrodynamic pressure is applied on leaflets 545, the leaflets will meet in the center 546 of frame 540 so as to seal the valve assembly. The shape of the leaflets in the valve assembly is determined by the boundary conditions, which in this case are the suture lines. The suture lines can be designed to have an optimal shape regarding the stress distribution in accordance with geometrical restrictions.

Reference is now made to Figures 41a to 41d illustrating isometric views of an implantable prosthesis tricuspid valve in accordance with yet another preferred embodiment of the present invention. Figure 41a illustrates valve assembly 553 in an open state. Valve assembly 553 comprises a frame 555 (rigid or crimpable), pericardial leaflets 550 and bars 551. It is emphasized that in the shown embodiment, the goal is to distribute the stresses on the commissural arrangement in an optimal way. Pericardial leaflets 550 are attached to bars 551 that act as attachment means. The attachment means are positioned at the top third of the valve; the bottom circumference is attached to the frame in order to obtain full sealing. The middle part of the pericardium is left slack. The pre-cut pericardium is cut in greater dimensions than the frame; e.g., the height of the pericardium leaflet is greater than the height of the frame, for example, if the frame height is 15 mm, the pericardium will be cut to a height of 18 mm so as to establish a slack portion in the middle area of the valve assembly 553. Figure 41b depicts the valve assembly in a closed state. The slack portion of the pericardium collapses toward the middle while creating a small pocket shape 554, which assists in the stress distribution. Figure 41c shows the detailed commissural and the short bar attachment as well as the circumference sealing area at the bottom portion of the pericardium assembly. It is shown in the figures that bars 551, which are relatively short, allow firm attachment of the top portion of the commissural, slack portion in the middle, and a good sealing surface at the bottom portion 556.

Reference is now made to Figures 42a and 42b illustrating an isometric view of an implantable prosthetic valve in accordance with yet another preferred embodiment of the present invention, having a different commissural attachment. Figure 42b depicts the attachment in details. In the embodiment shown in Figure 42a, similar valve assembly is

illustrated, while the short bar is arranged in a manner that is similar to the structure shown in Figure 28 and described herein before. Relatively short bars 559 act as the attachment means to the frame bar 558. Suture 557 attaches short bars 559 to a member 558, the suture can be made from an elastic material so that to add flexibility to the commissures and to render the valve assembly the benefits already explained herein.

Reference is now made to Figures 43a and 43b illustrating an isometric view of an implantable prosthetic valve in accordance with yet another preferred embodiment of the present invention. Figure 43a depicts commissures that are pre-sutured in a tapered shape. The valve assembly shown in Figure 43a comprises a frame 560, pericardial leaflets 563, and attachment means 561. Pericardial leaflets 563 are shown to be in an open state so as to establish an open valve assembly while dashed lines 565 show the valve in a closed sealed state. The attachment to the commissures can be performed using one of the explained techniques. Specifically to the embodiment shown in Figures 43a and 43b, the focus is on the formation of a tapered valve in which the attachment means is in the shape of long bars 561 that are attached to the pericardium in an angular way in apposition to the parallel attachment. Attaching the bars in an angular way when the pericardium is flattened will create a tapered tube when built up to the three dimensional shape. When the whole prosthetic valve is inflated by a balloon, the pericardium leaflet, at the top circumference of the frame, is stretched and the frame is expanded to the full diameter. After deflating the balloon, the frame stays in its expended size but the pericardial leaflets regains their pre-stretched shape. This process creates a permanent clearance distance 562 between the pericardial leaflets 563 and frame 560. This is of major importance in the protection of the pericardium from abrading against the frame.

Reference is now made to Figures 44a to 44c illustrating an isometric view of an implantable prosthetic valve in accordance with yet another preferred embodiment of the present invention, with additional pieces of PET used for sealing and protecting the pericardium. The illustrated implantable valve assembly resembles the valve shown in Figure 43, however, it is emphasized that in the attachment of the pericardial leaflets 570 to frame 575, there is use of PET. Figure 44c shows in a cross-sectional view, the way

the PET is assembled to the pericardium and the frame in a manner that protects the pericardium against wear. PET 571 and 572 are used for connecting pericardial leaflets 570 to frame 575, while they are assembled in between the leaflets and the frame. A suture 577 connects pericardium leaflet 570 in between two layers of PET, while the inner layer of PET 572 is short and the outer layer is longer. Bottom attachment suture 576, connects the three layers, the leaflet and both PET layers to the frame and forms a strong sealing line. An upper suture 578 connects the outer PET layer 571 to frame 575. When the valve assembly closes and the pericardial leaflets come closer to each other at the top of the assembly, there is a tendency of the bottom attachment to move and rotate about an attachment point 577. Upper suture line 578 keeps the outer PET layer tight and prevents a part of this rotational movement, which can rapidly cause an abrasion failure.

Figures 45a to 45d illustrate an isometric view of an implantable prosthetic valve in accordance with yet another preferred embodiment of the present invention, having leaflets sutured to a pre-shaped PET tube and optional leaflet-tube attachments in details. A novel technique of mounting pericardial leaflets 580 to a pre shaped PET tube 585 is shown. The tube is shaped so as to have a folding 586 with substantially sinusoid pattern 586 that is similar to the optimal connection line of valve leaflets in the natural valve. This shape allows the pericardial leaflets to be sutured to the interior of the PET tube. The preferred suturing techniques are shown in the cross sectional views of PET tubes in Figures 45b, 45c, and 45d. Generally, in order to protect the pericardial leaflets from tearing, an additional piece 583 of PET is added below the suture lines. Similar variations are shown in Figures 45c and 45d.

Reference is now made to Figure 46a illustrating an exploded view of an implantable prosthetic valve assembly in accordance with yet another preferred embodiment of the present invention, where the leaflets are mounted on a pre-cut and pre-shaped tube and the outlet of the valve is cut in a commissural shape. Figure 46a is view of the attachment. A pre-shaped PET tube 590 is cut to have substantially sinusoidal shape 596 and then bent in order to provide a suturing area. The pericardium leaflet 593 is pre-cut and assembled to PET tube 590 by means of suturing 502. In this case as well

as in the former case, an additional protective layer of PET or pericardium 594 is added. Figure 46b is a cross-section of the attachment detail after being tightened

Figures 47a to 47c illustrate a partial cross-sectional side view of an inflating balloon in accordance with a preferred embodiment of the present invention. The balloon is a part of an implantable prosthetic valve delivery system. Figures 47b and 47c are cross sectional upper views in the inflated and deflated positions, respectively. The specially designed balloon shown in the figures preferably comprises four inflating members, three substantially identical and symmetrical sections 600 and a central section 602. Pericardial leaflets 612 are positioned between sections 600 and separate them. A frame 610 circles the inflating members and a balloon shaft 619 that is positioned in the center of the delivery system while a commissural connection 613 connects pericardial leaflets 612 to frame 610. The inflated balloon sections 600 are placed between frame 610 and pericardial leaflets 612 so that when the inflating members are inflated, they push leaflets 612 toward each other and frame 610 so as to establish a fully closed position. This technique better preserves the leaflets since there is no contact between the leaflets and the frame besides in the commissural connection. The preservation of the leaflets is even improved in times of inflation as well as after inflating the valve and establishing a closed position. In Figure 47a the fourth inflating member of the balloon, central section 602 is clearly shown. Through central section 602, the inlet 617 of the valve is inflated while the inflated central section assures that the whole valve is fully inflated to substantially round shape. Figure 47c shows the assembly in a crimped position. Frame 610 is crimped and sections 600 are deflated. Pericardial leaflets 612 are also shown in a crimped configuration.

Figures 48a and 48b illustrate a partial cross-sectional side view and an upper cross sectional view of an inflating balloon in accordance with another preferred embodiment of the present invention. The inflating balloon comprises of a central inflating balloon 620 and three protection sheets 622. In the lateral cross-section shown in Figure 48b, the parts of inflated assembly 625 are clearly shown, protection sheets 622 protects the pericardial leaflets 624 from being pushed against the frame 625 when the

device is inflated. The advantage of this arrangement is in the protection of the pericardial leaflets.

The preferred embodiments representing an implantable prosthetic valve in accordance with the present invention are relatively easy to manufacture as they are generally flat throughout most of the production process and only at the final stage of mounting the other elements of the valve assembly on the support frame, a three dimensional form is established.

A typical size of an aortic prosthetic valve is from about 19 to about 25 mm in diameter. A maximal size of a catheter inserted into the femoral artery should be no more than 8 mm in diameter. The present invention introduces a device, which has the ability to change its diameter from about 4 mm to about 25 mm. Artificial valves are not new; however, artificial valves in accordance with the present invention possess the ability to change shape and size for the purpose of delivery and as such are novel. These newly designed valves require new manufacturing methods and technical inventions and improvements, some of which were described herein.

As mentioned earlier, the material of which the valve is made from can be either biological or artificial. In any case new technologies are needed to create such a valve.

To attach the valve to the body, the blood vessels determine the size during delivery, and the requirements for it to work efficiently, there is a need to mount it on a collapsible construction which can be crimped to a small size, be expanded to a larger size, and be strong enough to act as a support for the valve function. This construction, which is in somewhat similar to a large "stent", can be made of different materials such as Nitinol, biocompatible stainless steel, polymeric material or a combination of all. Special requirements for the stent are a subject of some of the embodiments discussed herein.

The mounting of the valve onto a collapsible stent is a new field of problems. New solutions to this problem are described herein.

Another major aspect of the design of the valve of the present invention is the attachment to the body.

In the traditional procedure the valve is sutured in place by a complicated suturing procedure. In the case of the percutaneous procedure there is no direct access to the implantation site therefore different attachment techniques are needed.

Another new problem that is dealt herein is the delivery procedure, which is new and unique. Positioning of the device in the body in an accurate location and orientation requires special marking and measuring methods of the device and surgical site as was disclosed herein.

Artificial polymer valves require special treatment and special conditions when kept on a shelf, as well as a special sterilization procedure. One of the consequences of the shelf treatment is the need to crimp the valve during the implantation procedure. A series of devices and inventions to allow the crimping procedure are disclosed herein.

It should be clear that the description of the embodiments and attached Figures set forth in this specification serves only for a better understanding of the invention, without limiting its scope as covered by the following claims.

It should also be clear that a person skilled in the art, after reading the present specification could make adjustments or amendments to the attached Figures and above described embodiments that would still be covered by the following claims.

## CLAIMS

1. A valve prosthesis device suitable for implantation in body ducts, the device comprising:

a support stent, comprised of a deployable construction adapted to be initially crimped in a narrow configuration suitable for catheterization through the body duct to a target location and adapted to be deployed by exerting substantially radial forces from within by means of a deployment device to a deployed state in the target location, the support stent provided with a plurality of longitudinally rigid support beams of fixed length; and

a valve assembly comprising a flexible conduit having an inlet end and an outlet, made of pliant material attached to the support beams providing collapsible slack portions of the conduit at the outlet,

whereby when flow is allowed to pass through the valve prosthesis device from the inlet to the outlet the valve assembly is kept in an open position, whereas a reverse flow is prevented as the collapsible slack portions of the valve assembly collapse inwardly providing blockage to the reverse flow.

2. The valve device of Claim 1, wherein the support stent comprises an annular frame.

3. The valve device of Claim 1, wherein said valve assembly has a tricuspid configuration.

4. The valve device of Claim 1, wherein said valve assembly is made from biocompatible material.

5. The valve device of Claim 4, wherein the valve assembly is made from pericardial tissue, or other biological tissue.

6. The valve device of Claim 1, wherein said valve assembly is made from biocompatible polymers.

7. The valve device of Claim 6, wherein the valve assembly is made from materials selected from polyurethane and polyethylene terephthalate.
8. The valve device of Claim 7, wherein said valve assembly comprises a main body made from polyethylene terephthalate and leaflets made from polyurethane.
9. The valve device of Claim 1, wherein said support stent is made from nickel titanium.
10. The valve device of Claim 1, wherein the support beams are substantially equidistant and substantially parallel so as to provide anchorage for the valve assembly.
11. The valve device of Claim 1, wherein the support beams are provided with bores so as to allow stitching or tying of the valve assembly to the beams.
12. The valve device of Claim 1, wherein the support beams are chemically adhered to the support stent.
13. The valve device of Claim 1, wherein said valve assembly is riveted to the support beams.
14. The valve device of Claim 1, wherein said valve assembly is stitched to the support beams.
15. The valve device of Claim 1, wherein said beams are manufactured by injection using a mold, or by machining.
16. The valve device of Claim 1, wherein said valve assembly is rolled over the support stent at the inlet.
17. The valve device of Claim 1, wherein said valve device is manufactured using forging or dipping techniques.
18. The valve device of Claim 1, wherein said valve assembly leaflets are longer than needed to exactly close the outlet, thus when they are in the collapsed state substantial portions of the leaflets fall on each other creating better sealing.



19. The valve device of Claim 1, wherein said valve assembly is made from a coiled polymer, coated by a coating layer of the same polymer.

20. The valve device of Claim 19, wherein said polymer is polyurethane.

21. The valve device of Claim 1, wherein the support stent is provided with heavy metal markers so as to enable tracking and determining the valve device position and orientation.

22. The valve device of Claim 21, wherein the heavy metal markers are selected from gold, platinum, iridium, or tantalum.

23. The valve device of Claim 1, wherein the valve assembly leaflets are provided with radio-opaque material at the outlet, so as to help tracking the valve device operation *in vivo*.

24. The valve device of Claim 23, wherein said radio-opaque material comprises gold thread.

25. The valve device of Claim 1, wherein the diameter of said support stent, when fully deployed is in the range of from about 19 to about 25 mm.

26. The valve device of Claim 1, wherein the diameter of said support stent may be expanded from about 4 to about 25 mm.

27. The valve device of Claim 1, wherein the support beams are provided with bores and wherein the valve assembly is attached to the support beams by means of u-shaped rigid members that are fastened to the valve assembly and that are provided with extruding portions that fit into matching bores on the support beams.

28. The valve device of Claim 1, wherein the support beams comprise rigid support beams in the form of frame construction, and the valve assembly pliant material is inserted through a gap in the frame and a fastening rod is inserted through a pocket formed between the pliant material and the frame and holds the valve in position.

29. The valve device of Claim 1, wherein the main body of the valve assembly is made from coiled wire coated with a coating material.

30. The valve device of Claim 31, wherein the coiled wire and the coating material is made from polyurethane.

32. The valve device of Claim 1, wherein a strengthening wire is interlaced in the valve assembly at the outlet of the conduit so as to define a fault line about which the collapsible slack portion of the valve assembly may flap.

33. The valve device of Claim 32, wherein the strengthening-wire is made from nickel titanium alloy.

33. A valve prosthesis device suitable for implantation in body ducts, the device comprising a main conduit body having an inlet and an outlet and pliant leaflets attached at the outlet so that when a flow passes through the conduit from the inlet to the outlet the leaflets are in an open position allowing the flow to exit the outlet, and when the flow is reversed the leaflets collapse so as to block the outlet, wherein the main body is made from polyethylene terephthalate and collapsible leaflets are made from polyurethane.

34. The valve device of Claim 33, wherein support beams made from polyurethane are provided on the main body and wherein the leaflets are attached to the main body at the support beams.

35. The valve device of Claim 33, wherein said support beams are chemically adhered to the main body.

36. A valve prosthesis device suitable for implantation in body ducts, the device comprising:

support stent, comprised of a deployable construction adapted to be initially crimped in a narrow configuration suitable for catheterization through the body duct to a target location and adapted to be deployed by exerting substantially radial forces from within by means of a deployment device to a deployed state in the target location,

the support stent provided with a plurality of longitudinally rigid support beams of fixed length;

valve assembly comprising a flexible conduit having an inlet end and an outlet, made of pliant material attached to the support beams providing collapsible slack portions of the conduit at the outlet;

substantially equidistant rigid support beams interlaced or attached to the slack portion of the valve assembly material, arranged longitudinally.

37. A crimping device for crimping the valve device of Claim 1, the crimping device comprising a plurality of adjustable plates that resemble a typical SLR camera variable restrictor, each provided with a blade, that are equally dispersed in a radial symmetry but each plate moves along a line passing off an opening in the center, all plates equidistant from that center opening.

38. The crimping device of Claim 37, wherein the multiple plates are adapted to move simultaneously by means of a lever and transmission.

39. A method for deploying an implantable prosthetic valve device at the natural aortic valve position at the entrance to the left ventricle of a myocardium of a patient, the method comprising the steps of:

(a) providing a balloon catheter having a proximal end and a distal end, having a first and second independently inflatable portions, the first inflatable portion located at the distal end of the catheter and the second inflatable portion adjacently behind the first inflatable portion;

(b) providing a guiding tool for guiding the balloon catheter in the vasculature of the patient;

(c) providing a deployable implantable valve prosthesis device adapted to be mounted on the second inflatable portion of the balloon catheter

(d) guiding the balloon catheter through the patient's aorta or trans-septally traversing the artial septum and the left ventricle using the guiding tool, the valve

device mounted over the second inflatable portion of the balloon catheter until the first inflatable portion of the balloon catheter is inserted into the left ventricle or aorta (in the antegrade approach), whereas the second inflatable portion of the balloon catheter is positioned at the natural aortic valve position;

(e) inflating the first inflatable portion of the balloon catheter so as to substantially block blood flow through the natural aortic valve and anchor the distal end of the balloon catheter in position;

(f) inflating the second inflatable portion of the balloon catheter so as to deploy the implantable prosthetic valve device in position at the natural aortic valve position;

(g) deflating the first and second inflatable portions of the balloon catheter; and

(h) retracting the balloon catheter and removing it from the patient's body.

40. The method of Claim 39, wherein the guiding tool comprises a guide wire.

41. A method for deploying an implantable prosthetic valve device at the natural aortic valve position at the entrance to the left ventricle of a myocardium of a patient, the method comprising the steps of:

(a) providing a balloon catheter having a proximal end and a distal end, having a first and second independently inflatable portions, the first inflatable portion located at the distal end of the catheter and the second inflatable portion adjacently behind the first inflatable portion;

(b) providing a guiding tool for guiding the balloon catheter in the vasculature of the patient;

(c) providing a deployable implantable valve prosthesis device adapted to be mounted on the first inflatable portion of the balloon catheter, and a deployable annular stent device adapted to be mounted over the second inflatable portion of the balloon catheter, the deployable implantable valve prosthesis device and the deployable annular stent kept at a predetermined distant apart;

(d) guiding the balloon catheter through the patient's aorta using the guiding tool, the valve device mounted over the first inflatable portion of the balloon catheter and the deployable annular stent mounted over the second inflatable portion of the balloon catheter, until the first inflatable portion of the balloon catheter is positioned at the natural aortic valve position;

(e) inflating the second inflatable portion of the balloon catheter so that the deployable stent device is deployed within the ascending aorta thus anchoring the deployable annular stent and the coupled valve device in position;

(f) inflating the first inflatable portion of the balloon catheter so as to deploy the implantable prosthetic valve device in position at the natural aortic valve position;

(g) deflating the first and second inflatable portions of the balloon catheter; and

(h) retracting the balloon catheter and removing it from the patient's body.

42. A valve prosthesis device suitable for implantation in body ducts, the device comprising:

an expandable support frame, the support frame provided with a plurality of longitudinally rigid support beams of fixed length; and

a valve assembly comprising a flexible conduit having an inlet end and an outlet, made of pliant material attached to the support beams providing collapsible slack portions of the conduit at the outlet,

whereby when flow is allowed to pass through the valve prosthesis device from the inlet to the outlet the valve assembly is kept in an open position, whereas a reverse flow is prevented as the collapsible slack portions of the valve assembly collapse inwardly providing blockage to the reverse flow.

43. The prosthetic device of Claim 42, wherein the expandable support frame comprises a deployable construction adapted to be initially crimped in a narrow configuration suitable for catheterization through the body duct to a target location and adapted to be deployed by exerting substantially radial forces from within by means of a deployment device to a deployed state in the target location.

44. The prosthetic of Claim 42, wherein the support beams have a U-shaped cross section.

45. The prosthetic device of Claim 44, wherein a holder is used to secure the pliant material to the support beams.

46. The prosthetic device of Claim 42, wherein the support frame comprises three segments that form a circular assembly when assembled.

47. The prosthetic device of Claim 42, wherein the support beams point inwardly with respect to a central longitudinal axis of the device.

48. The prosthetic device of Claim 46, wherein the support beams point outwardly with respect to a central longitudinal axis of the device.

49. The prosthetic device of Claim 42, further provided with a restricting tapered housing, for housing it in a crimped state

50. The prosthetic device of Claim 42, wherein hooks are provided to secure the device in position after it is deployed.

51. The prosthetic device of Claim 42, wherein the support beams comprise longitudinal bars having a narrow slit used as the commissural attachment so that extensions the pliant material are tightly inserted through it.

52. The prosthetic device of Claim 51, wherein the extensions of the pliant material are wrapped about rigid bars serving as anchorage means.

53. The prosthetic device of Claim 52, wherein extensions of the pliant material are sutured to each other at the rigid bars.

54. The prosthetic device of Claim 53, wherein a bottom portion of the pliant material is attached to the inlet.

55. The prosthetic device of Claim 42, wherein the support beams are each provided with a rounded pole, forming a loop through which the pliant material is inserted.

56. The prosthetic device of Claim 42, wherein the pliant material is provided with longitudinal bars attached to the pliant material at positions assigned for attachment to the support frame, in order to prevent localized stress from forming.

57. The prosthetic device of Claim 42, further provided with longitudinal bars having protrusions that are inserted in bores in the pliant material, a sheet of PET and through bores provided on the support beams.

58. The prosthetic device of Claim 42, wherein the pliant material is sutured leaving the slack portions free of sutures.

59. The prosthetic device of Claim 42, wherein a connecting member with a split portion is used to connect leaflets of the pliant material to the support beams, the split connecting member compressing the pliant material in position.

60. The prosthetic device of Claim 59, wherein a portion of the connecting member is perpendicular to the split portion.

61. The prosthetic device of Claim 42, wherein the support frame is provided with metallic members coupled to the stent and rigid members are positioned on two opposite sides of the metallic member and held against each other, holding portion of the pliant material between them, sutured, the metallic members wrapped with PET.

62. The prosthetic device of Claim 42, wherein the device is further provided with spring in order to reduce wear of the pliant material.

63. The prosthetic device of Claim 62, wherein the spring is provided with a spiral.

64. The prosthetic device of Claim 62, wherein the spring is made from stainless steel.

65. The prosthetic device of Claim 62, wherein the spring is attached to slots provided on the support frame.

66. The prosthetic device of Claim 42, wherein the pliant material is sutured to the support frame forming pockets.

67. The prosthetic device of Claim 66, wherein attachment bars are provided on the stent support at a portion of the stent close to the outlet, on which the pliant material is coupled to, and wherein the pliant material is attached circumferentially to the inlet, leaving slack pliant material.

68. The prosthetic device of Claim 42, wherein the outlet is tapered with respect to the inlet.

69. The prosthetic device of Claim 68, wherein the support frame at the outlet is wider in diameter than the pliant material forming the outlet.

70. The prosthetic device of Claim 42, wherein the pliant material is reinforced using PET.

71. The prosthetic device of Claim 42, wherein the support frame is a tube having an inner wall, having sinusoidal fold lines, wherein the pliant material is sutured to the inner wall of the tube along suture lines.

72. The prosthetic device of Claim 71, wherein additional piece of PET is added below the suture lines.



73. The prosthetic device of Claim 42, wherein the device is incorporated with an angioplasty balloon.

74. The prosthetic device of Claim 73, wherein the balloon has a central longitudinal axis that runs along a flow path through the device, and a perimeter, the balloon comprising four inflatable portions, one portion located along a central axis and the other three located on the perimeter, the pliant material in the form of leaflets is distributed about the perimeter.

FIG. 1

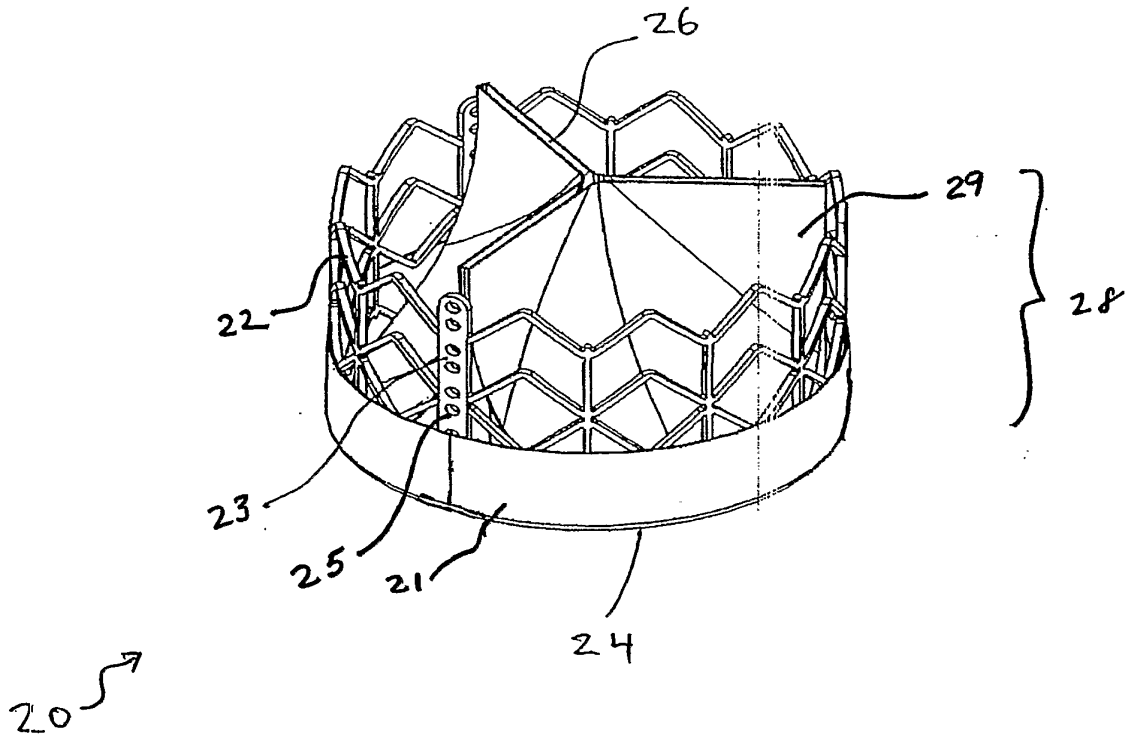
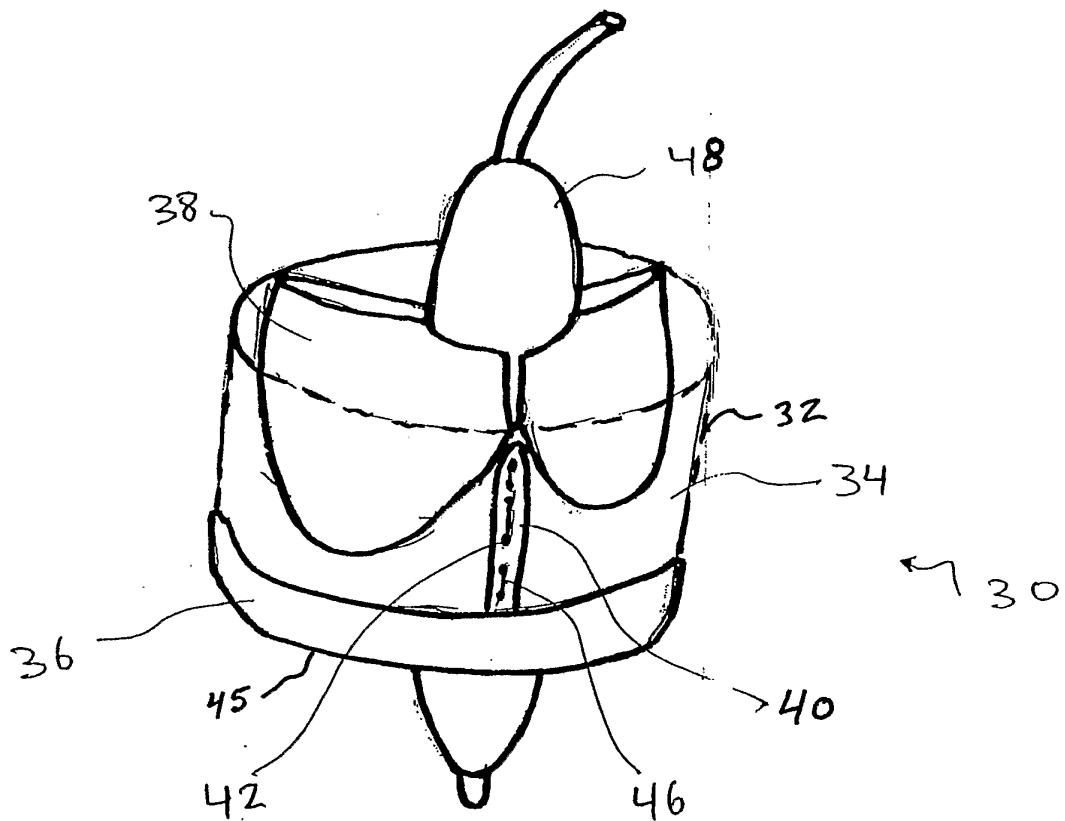


FIG. 2



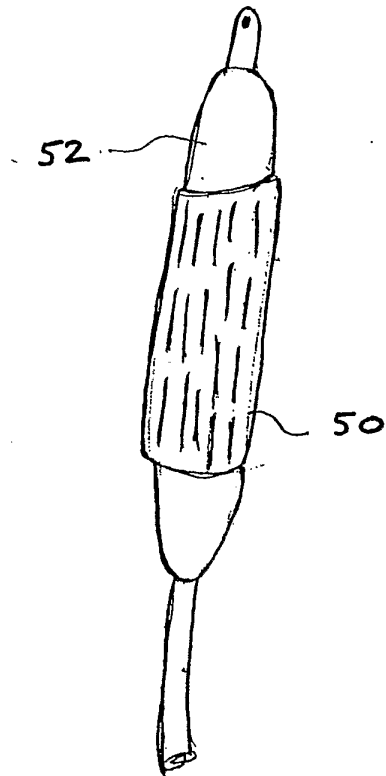


FIG. 3

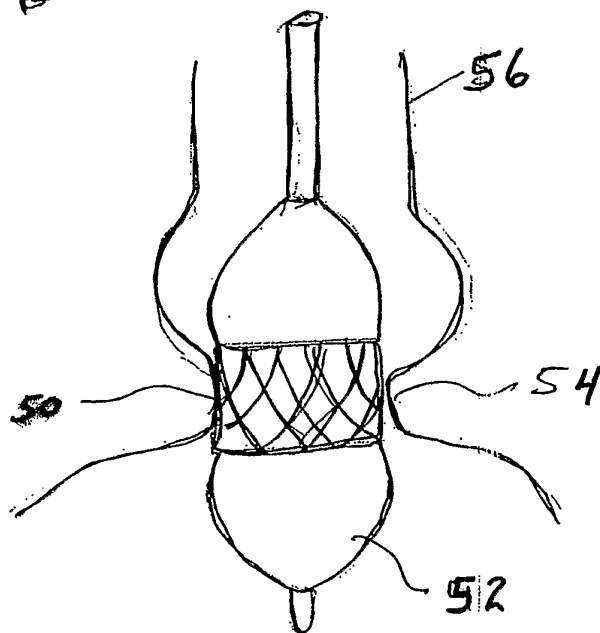
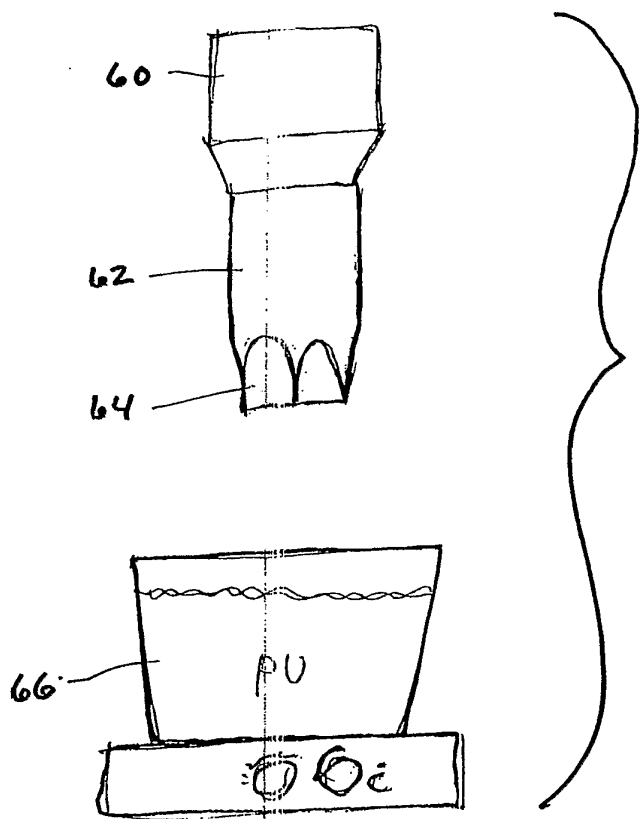


FIG. 4

FIG. 5



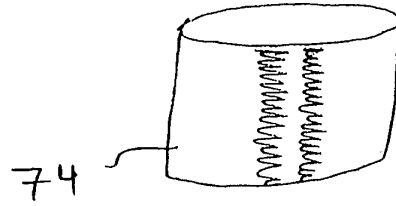


Fig. 6a

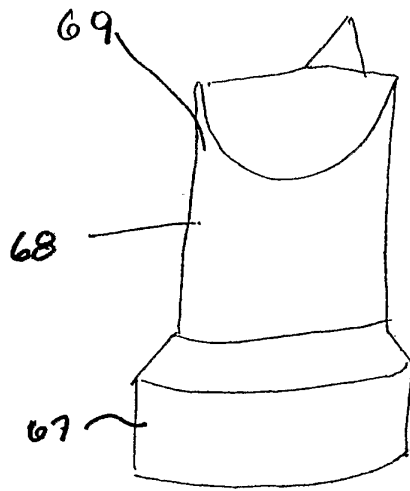


Fig. 6b

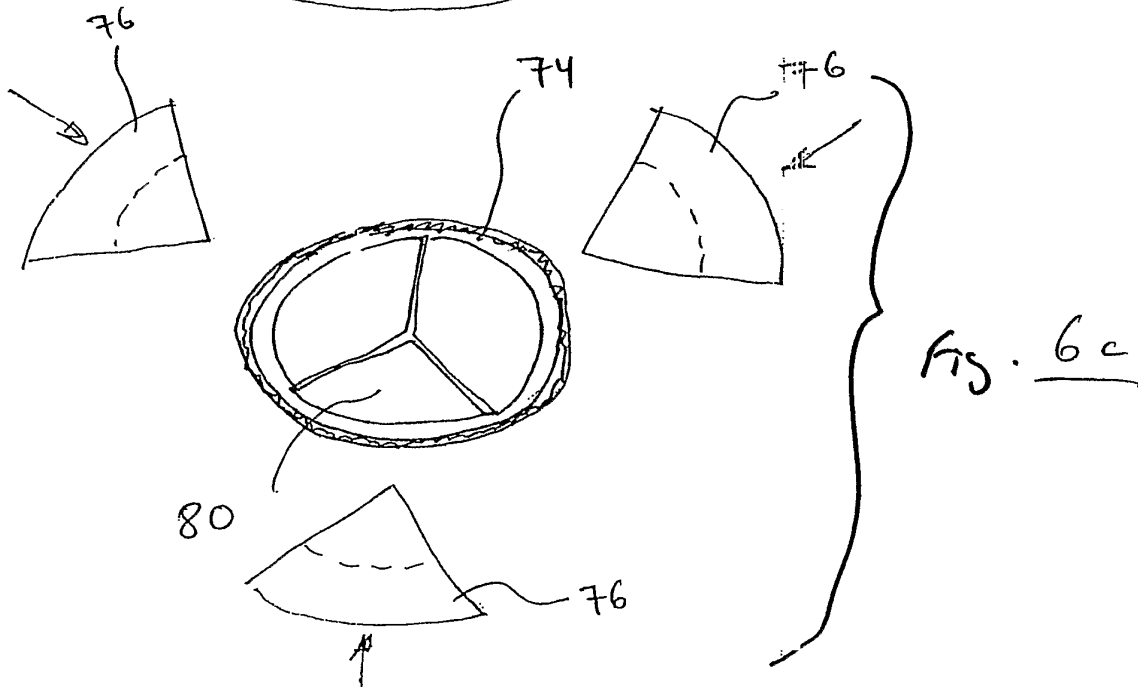
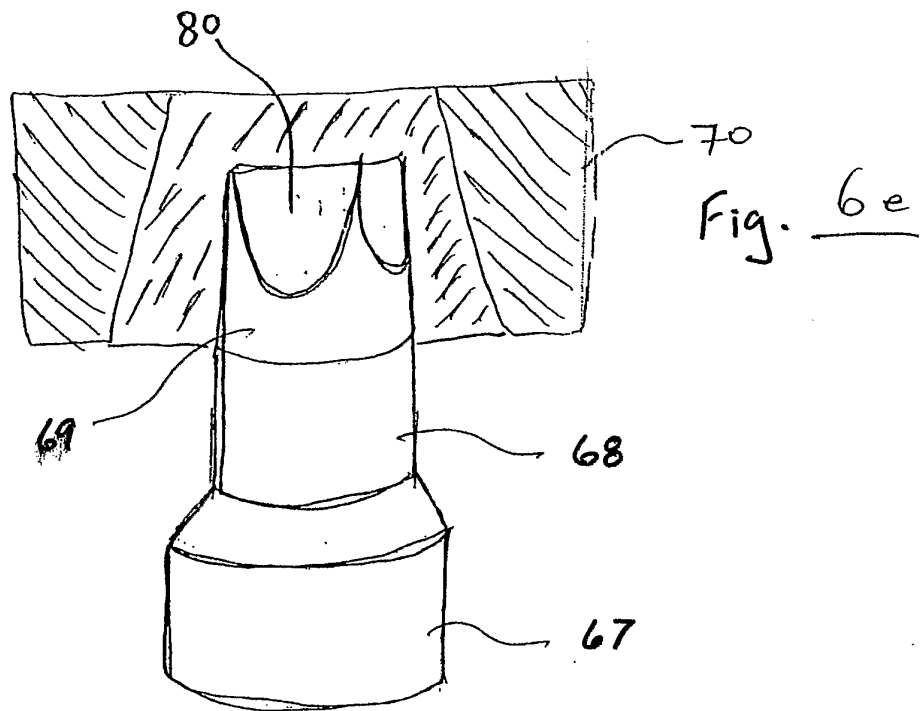
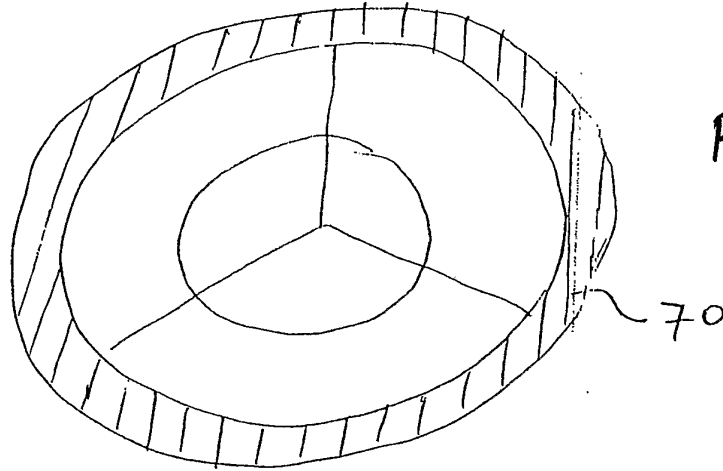


Fig. 6c



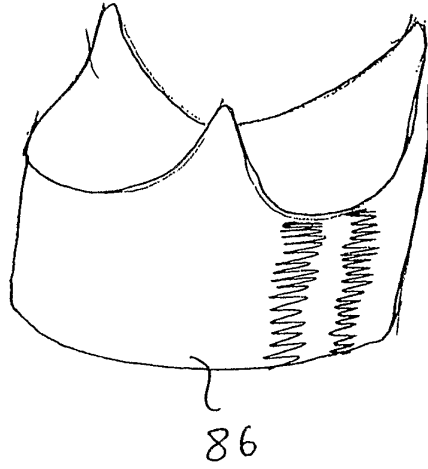


FIG. 7a

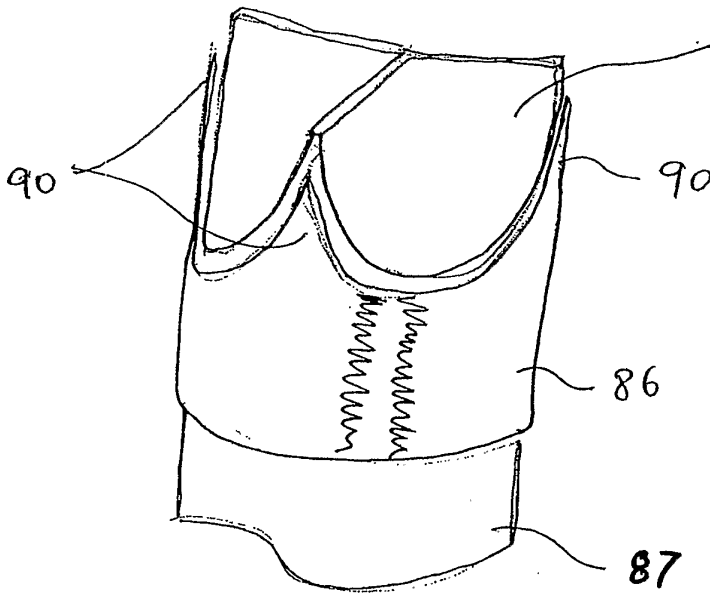


Fig. 7b



FIG 8a

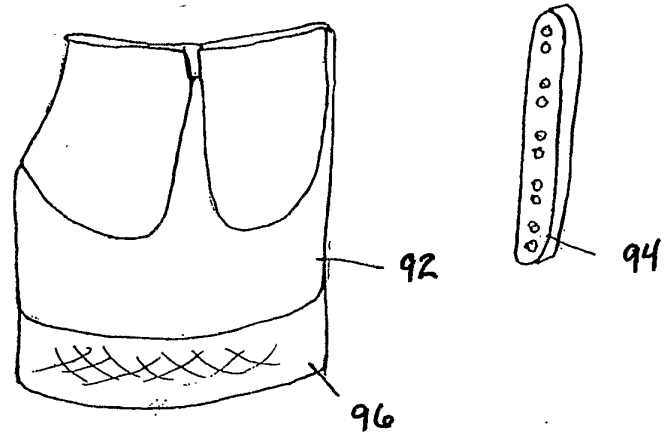


Fig. 8b

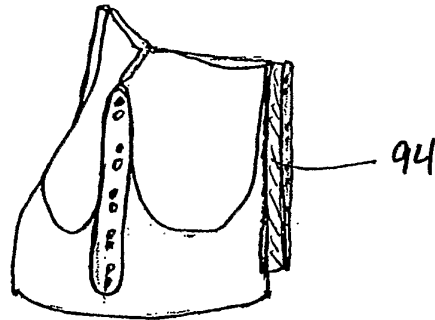


FIG. 9

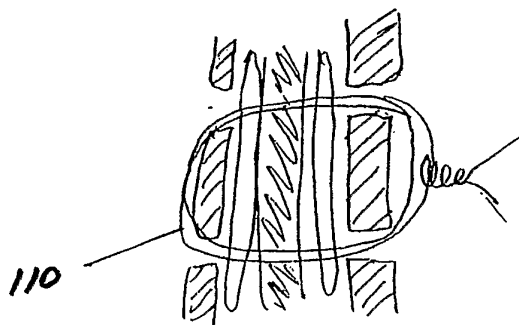
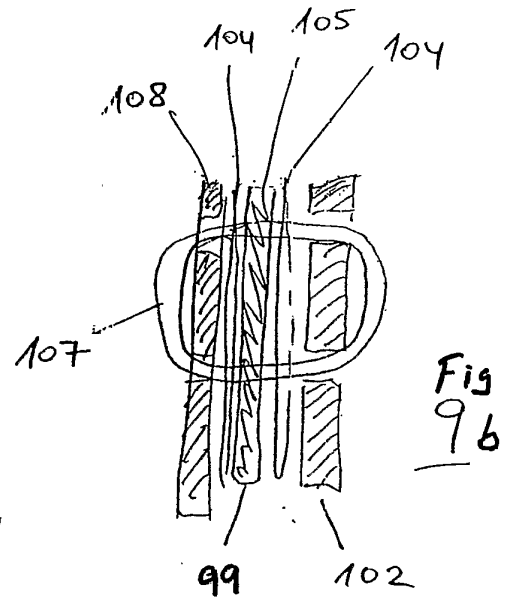
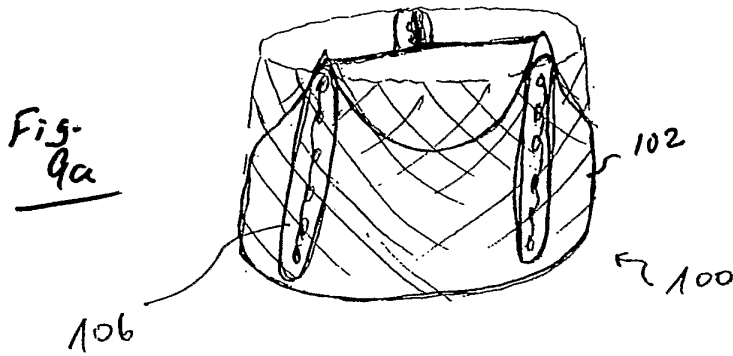
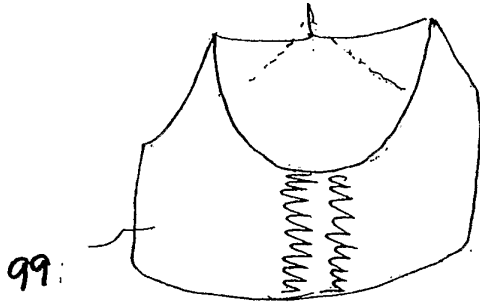


Fig. 9d

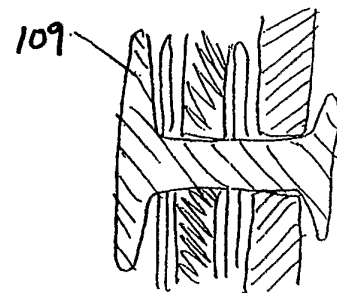
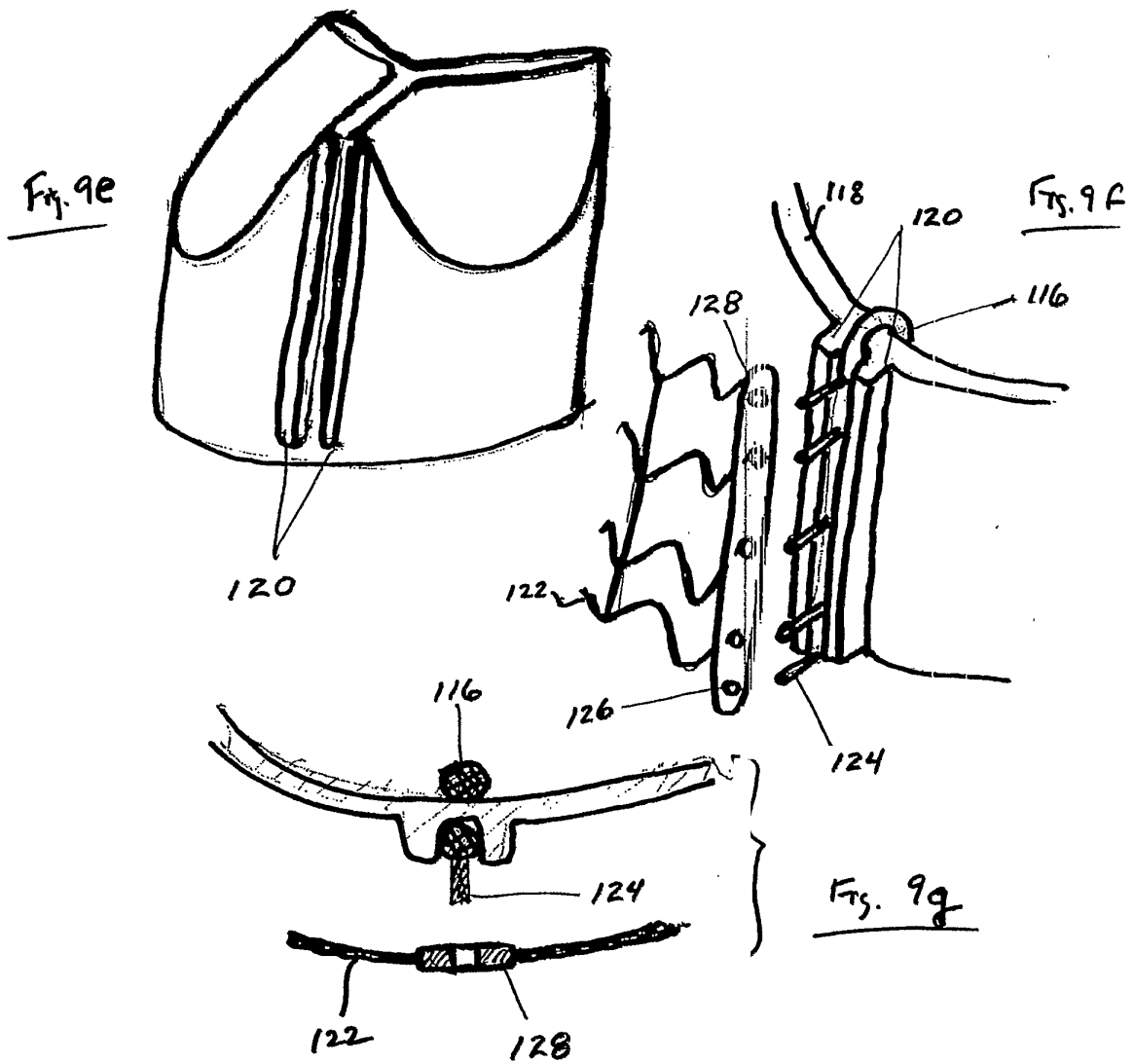


Fig. 9c



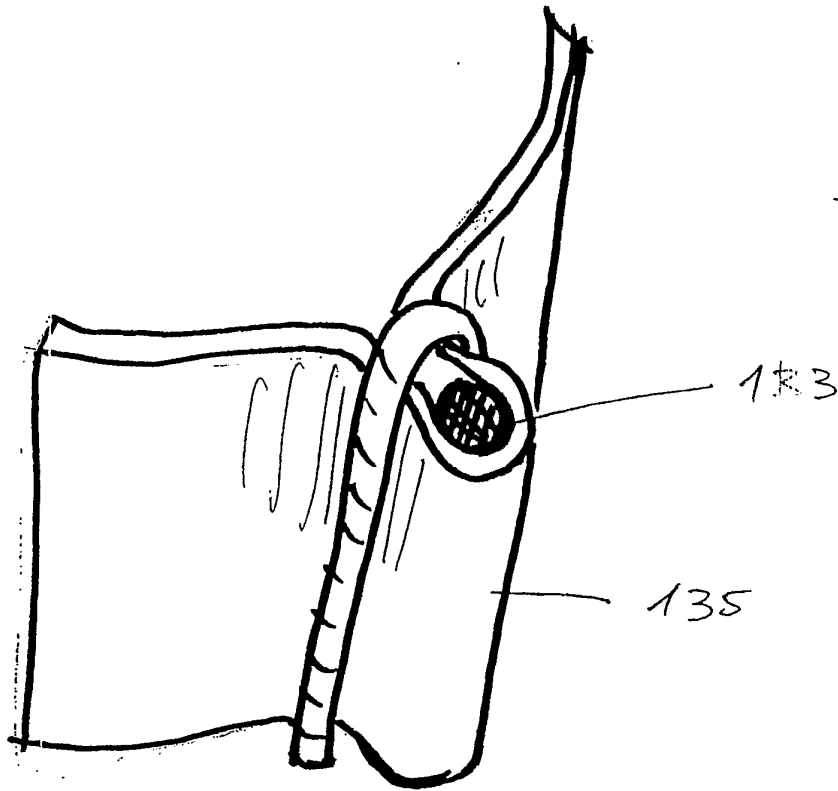


Fig. 9h

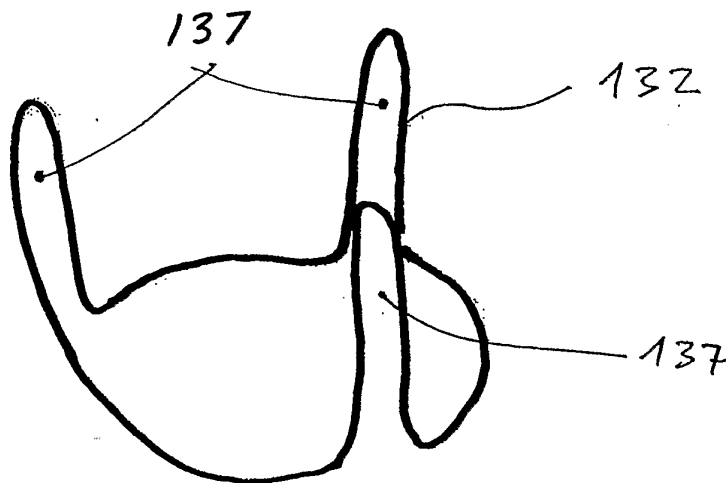
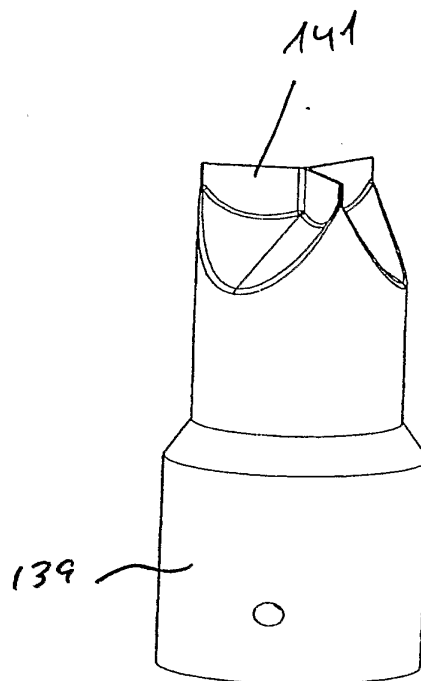
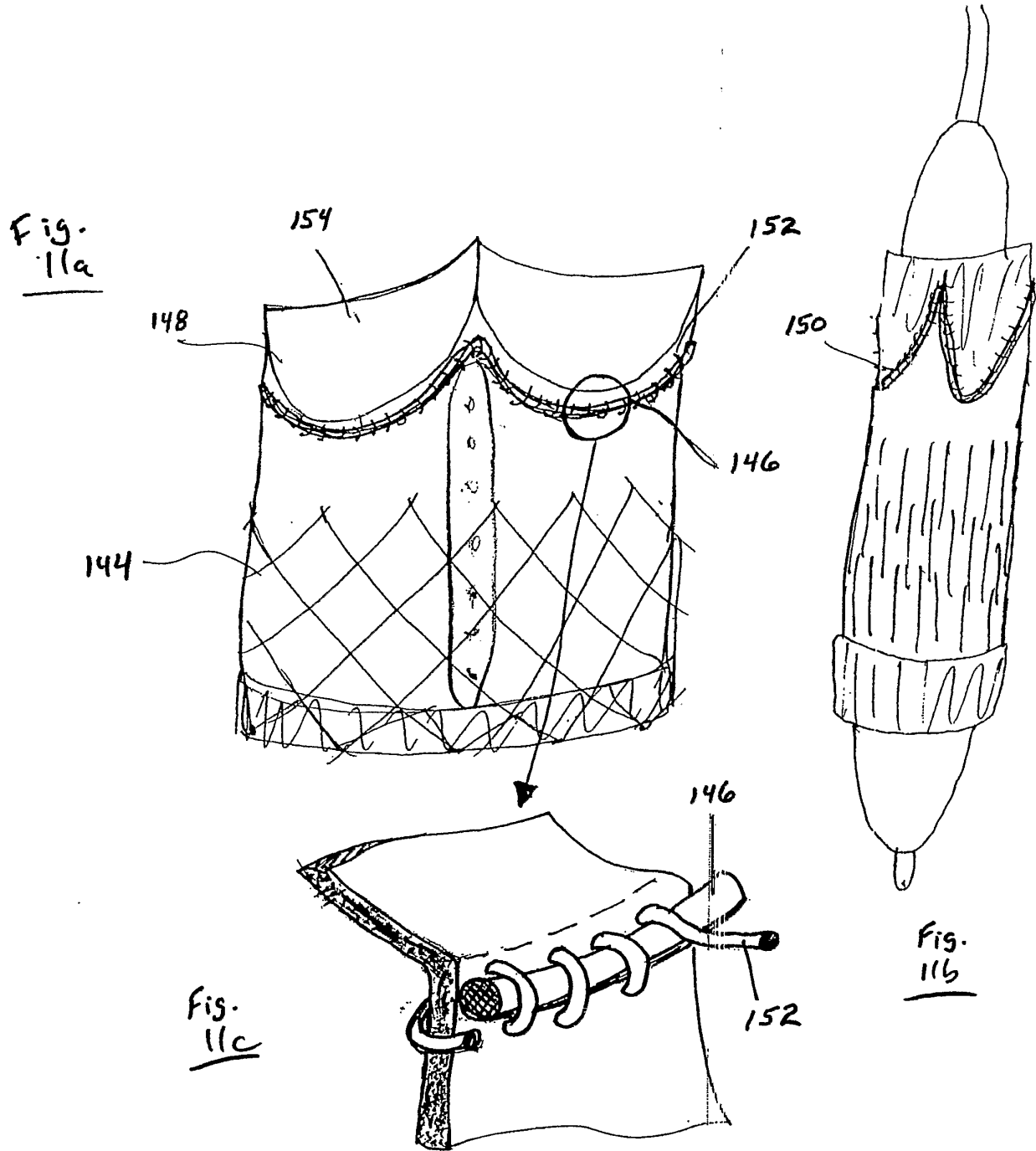


Fig. 9i

FIG 10





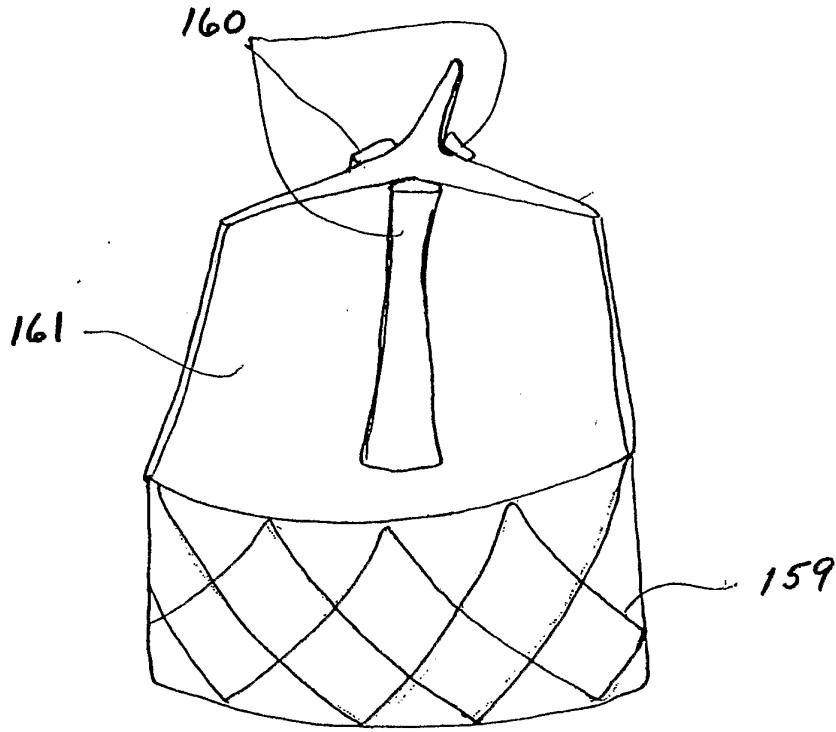


Fig. 129

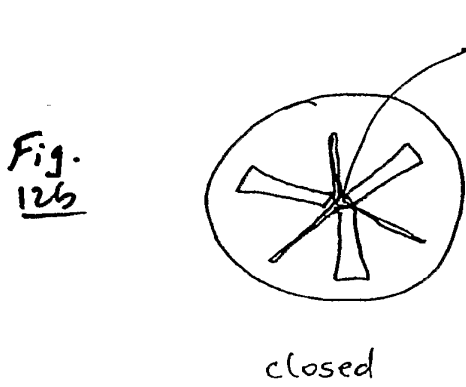


Fig. 126

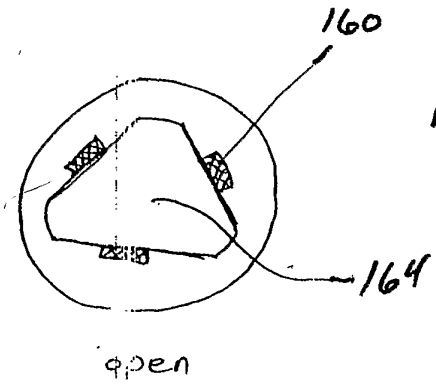


Fig. 12c

Fig. 13a

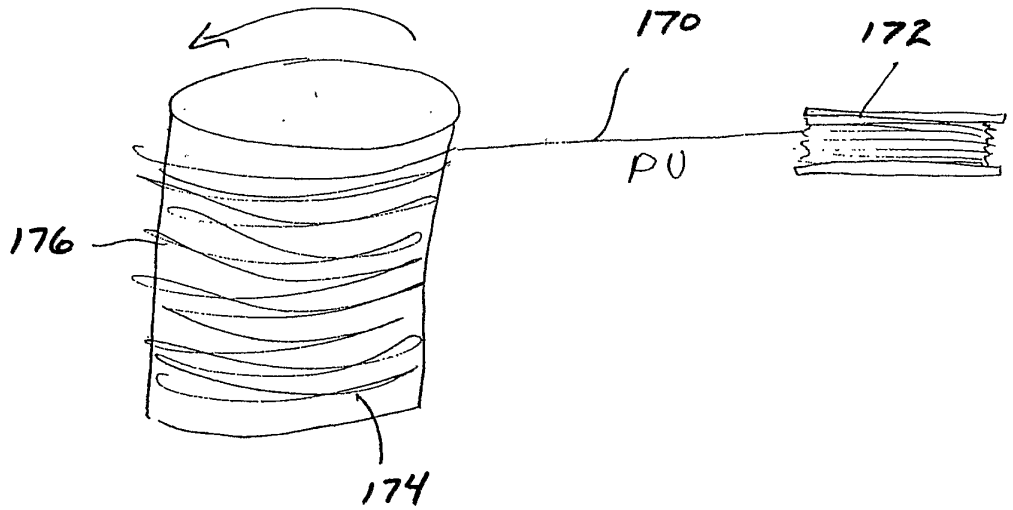


Fig. 13b

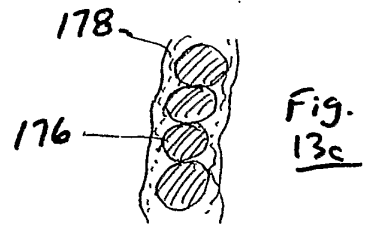
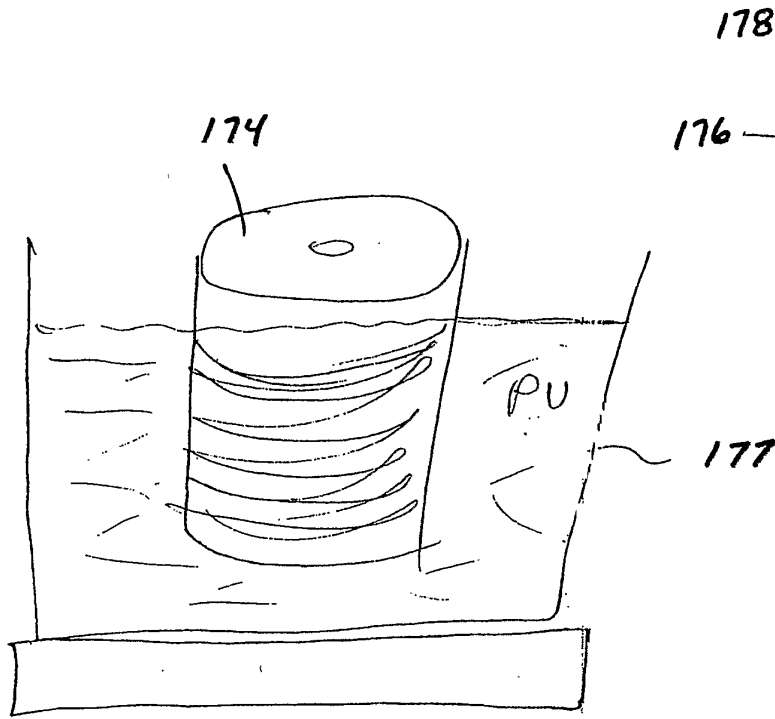




FIG 14

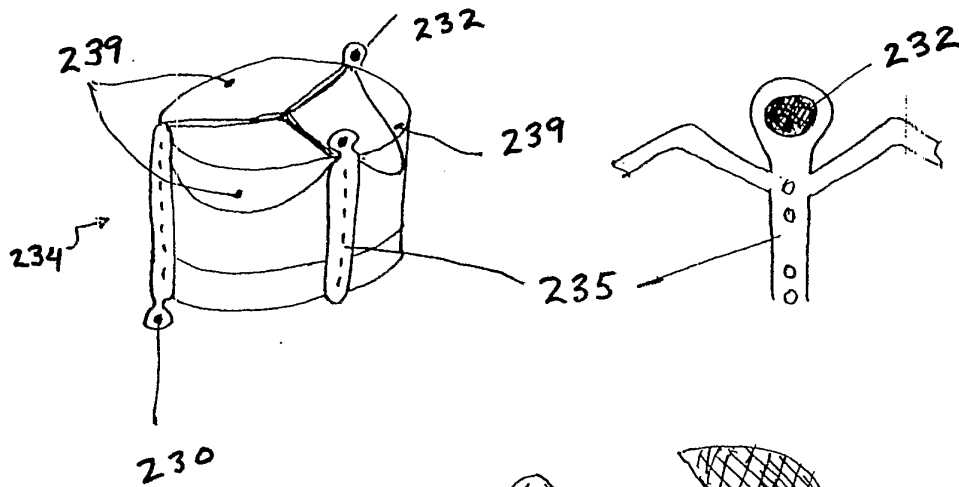


Fig. 14a

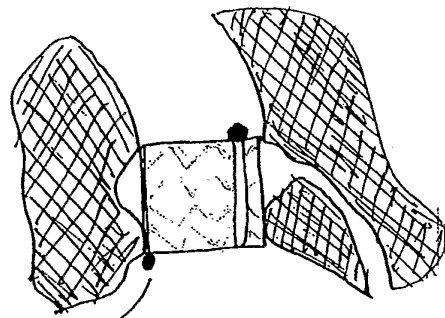


Fig. 14b

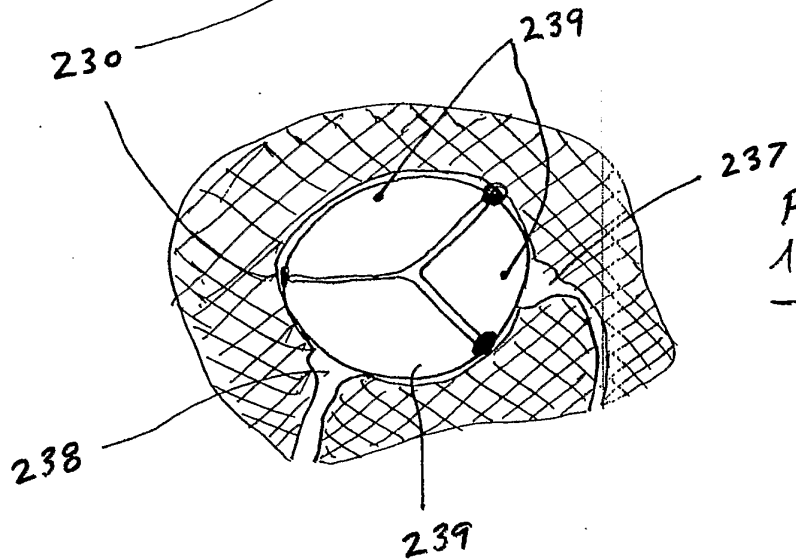
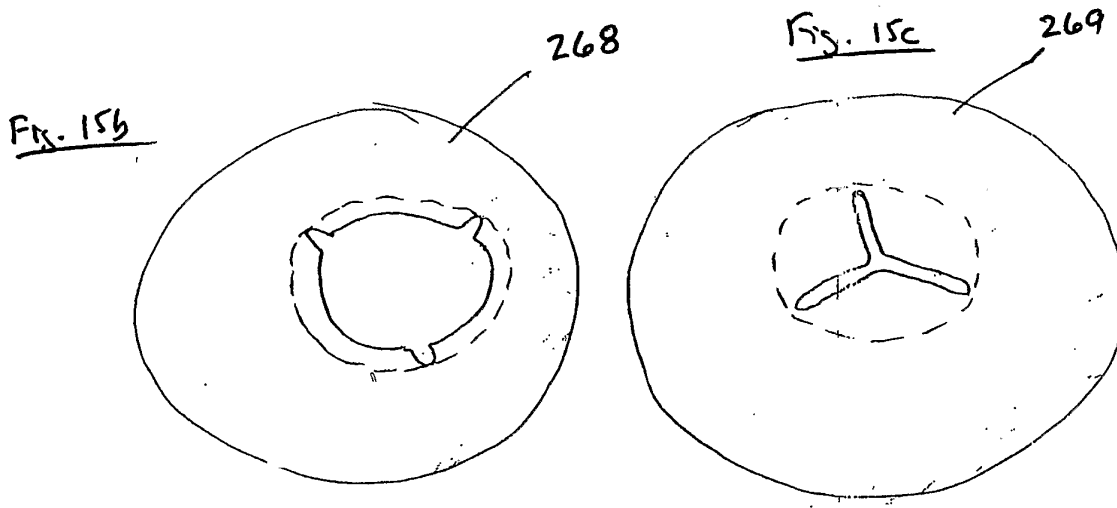
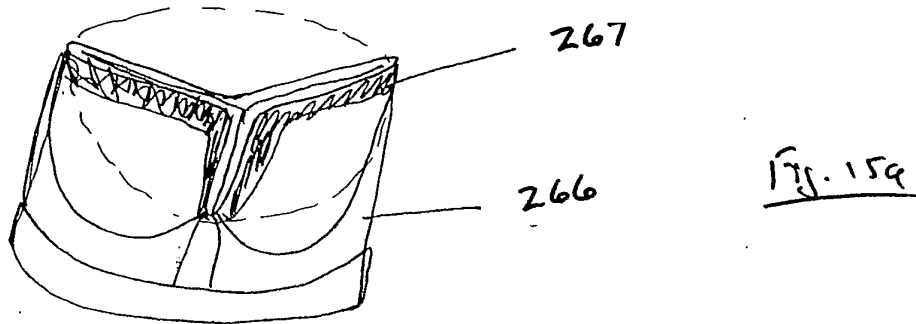


Fig. 14c



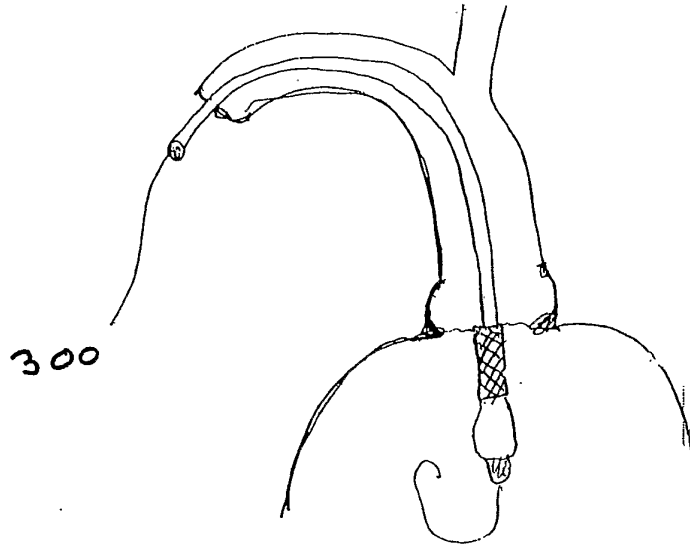


Fig. 16a

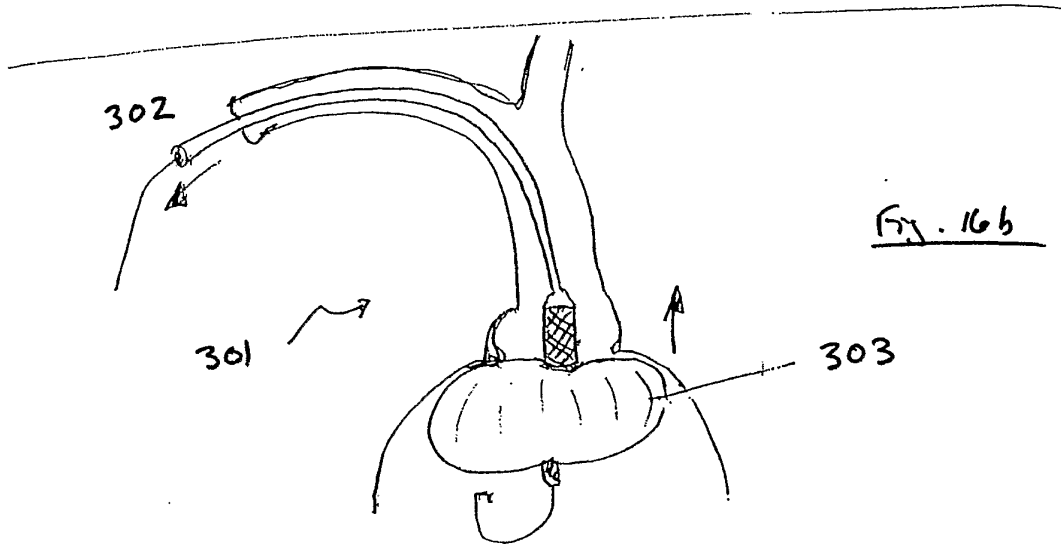


Fig. 16b

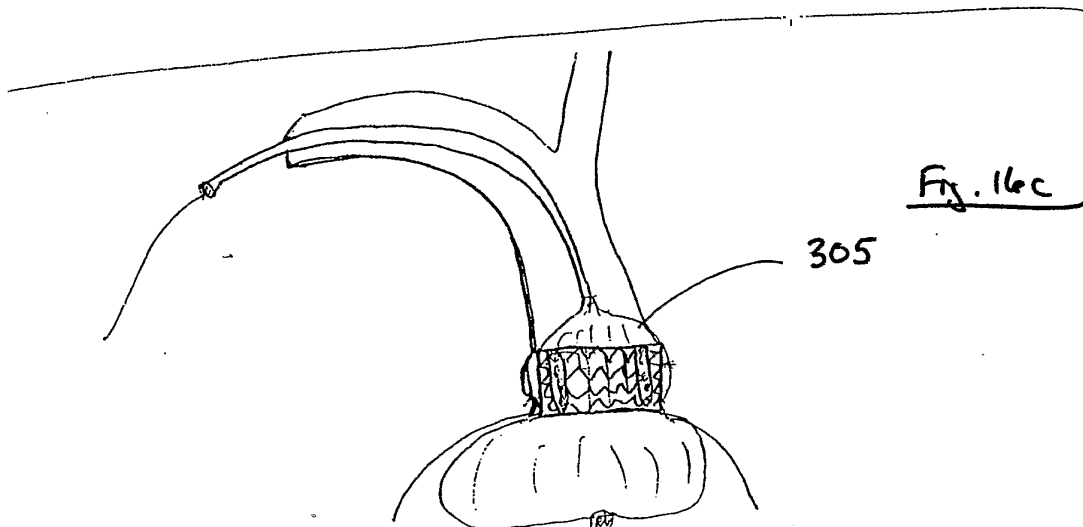


Fig. 16c

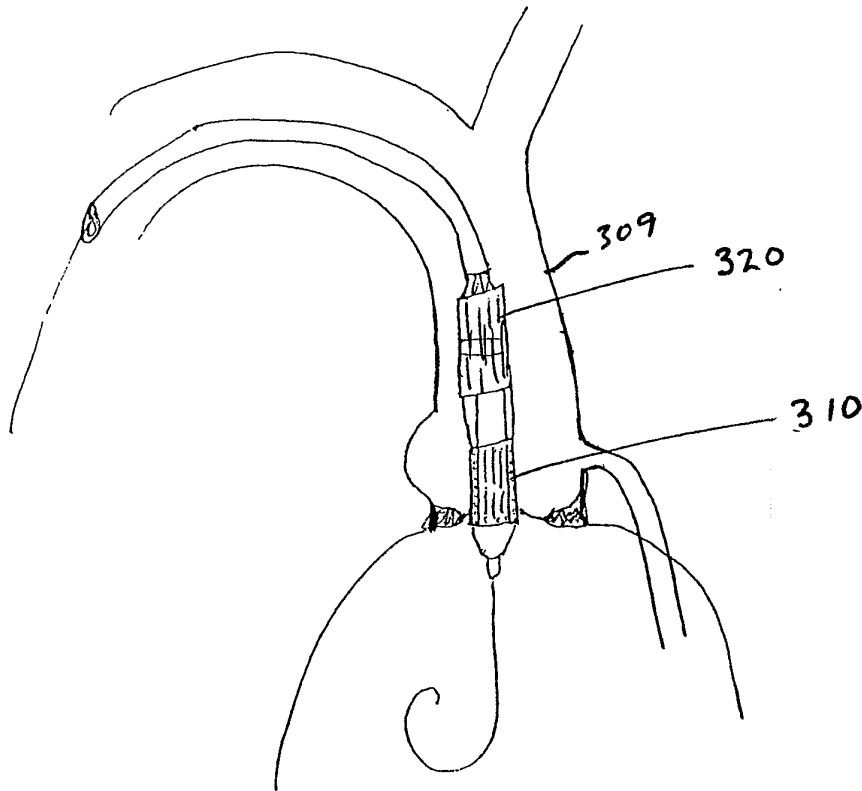


Fig. 17a

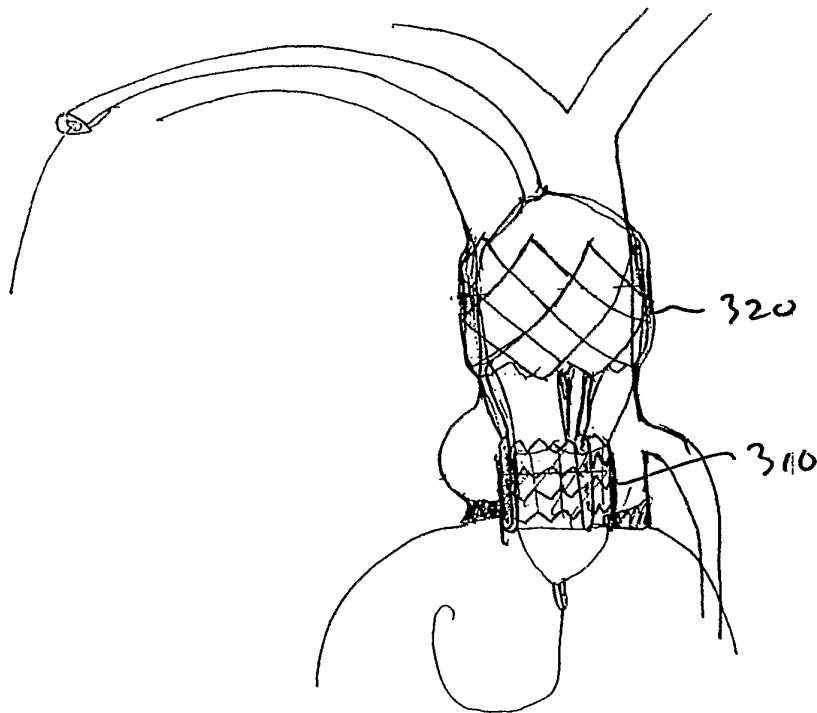


Fig. 17b

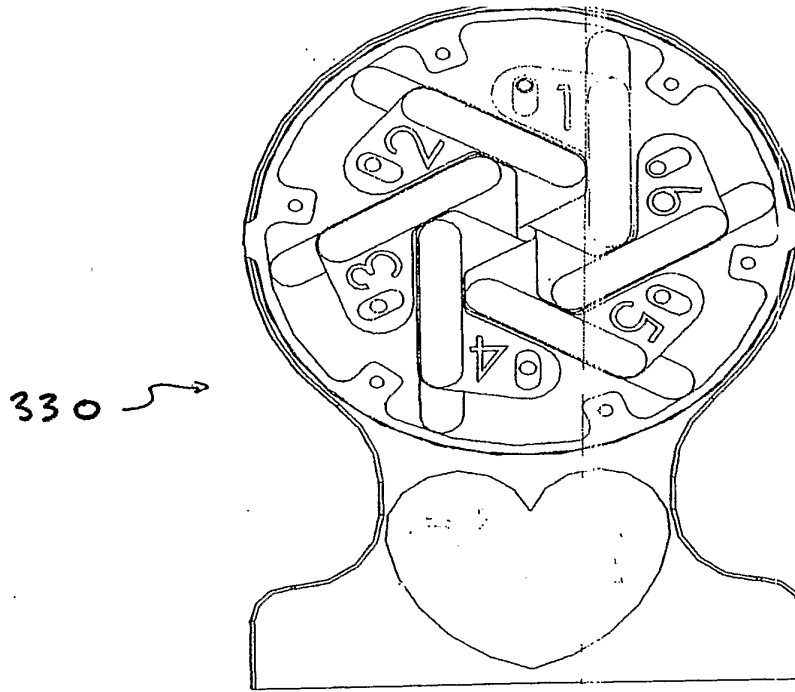
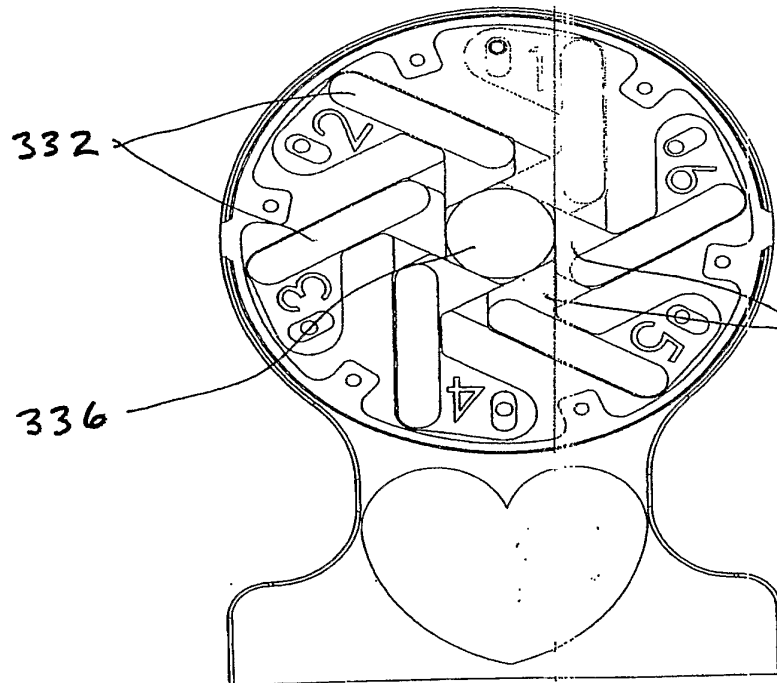


Fig. 18b



330

Fig. 18a

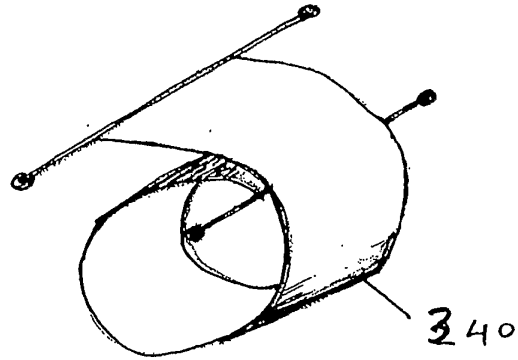


Fig. 19a

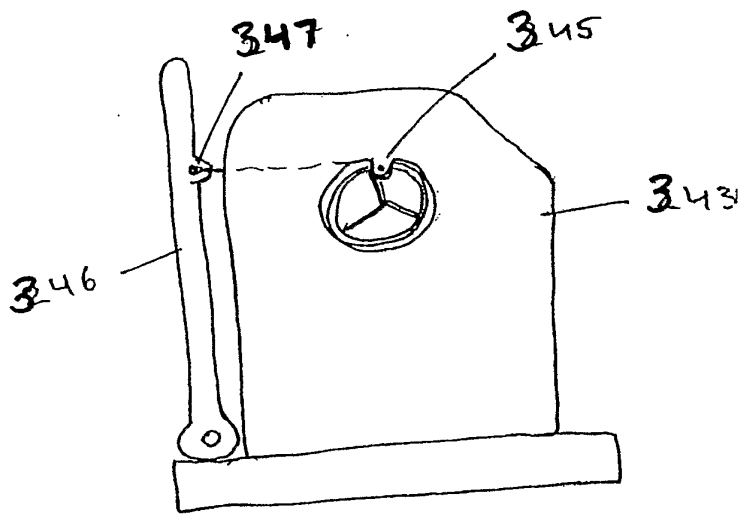


Fig. 19b

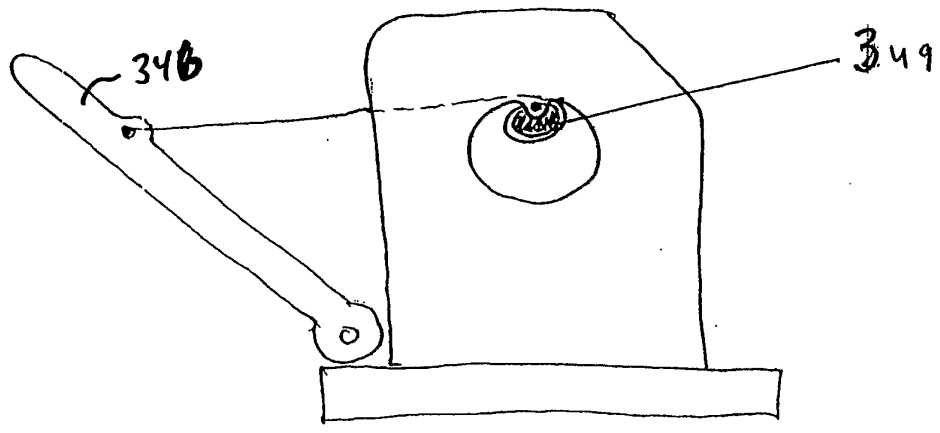


Fig. 19c

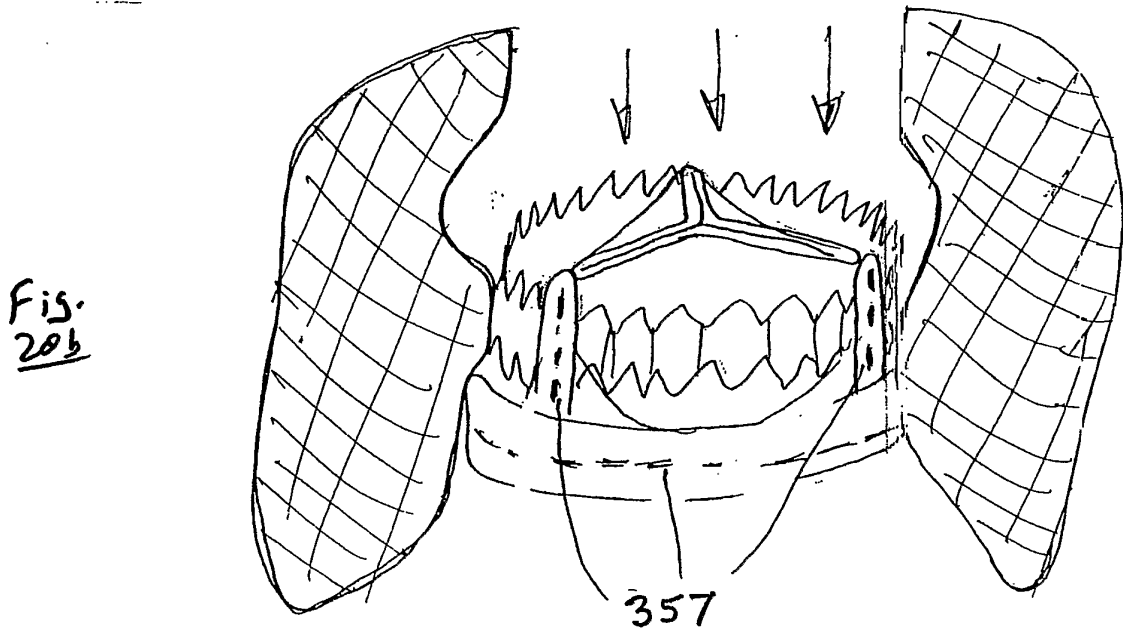
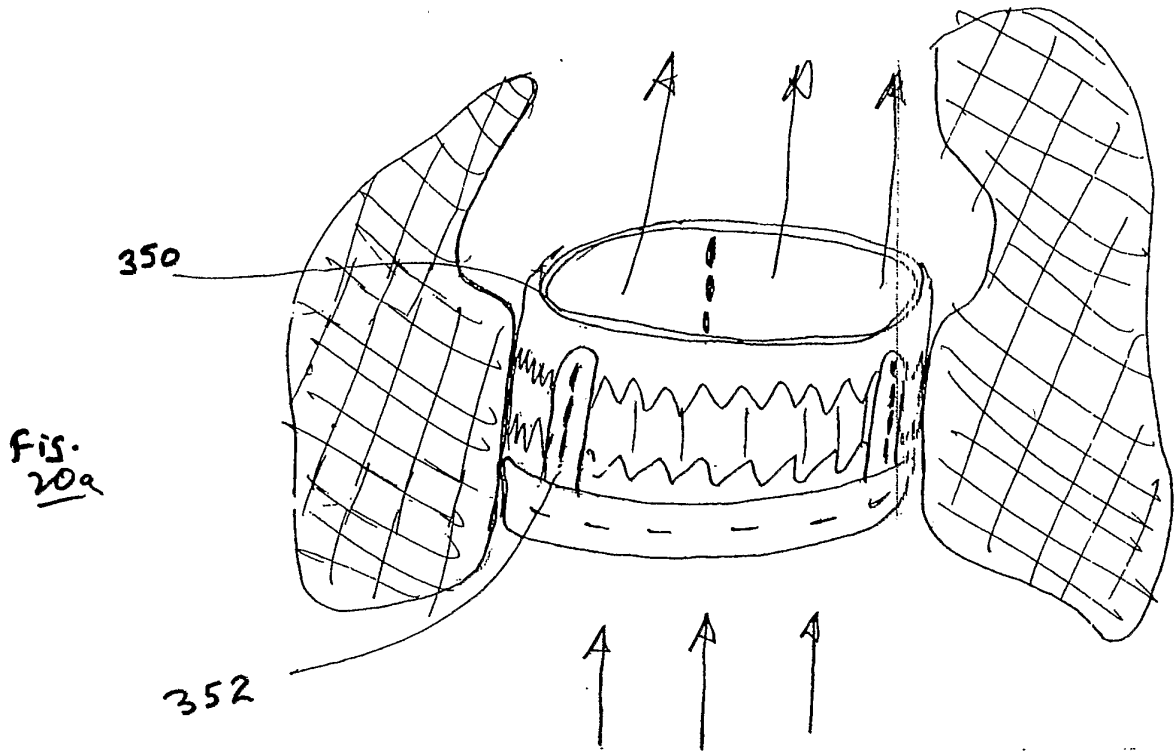


FIG 21

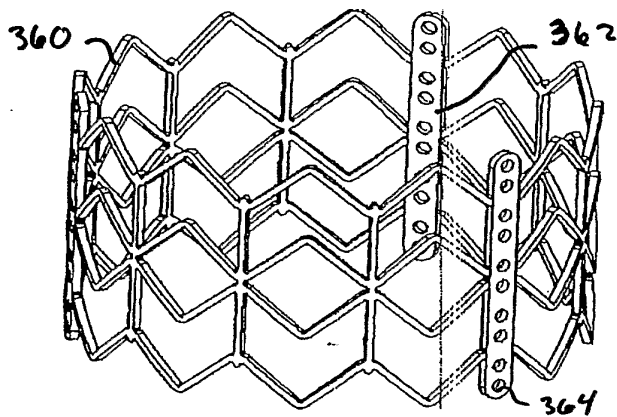




FIG 22

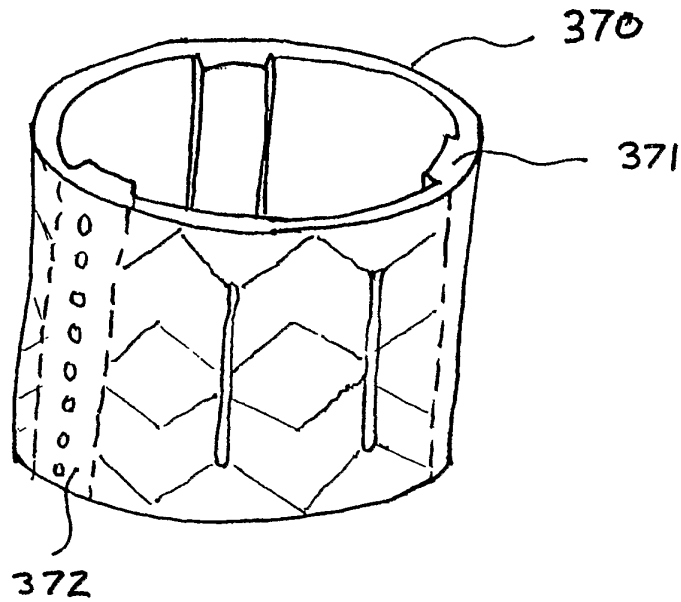




Fig. 23a

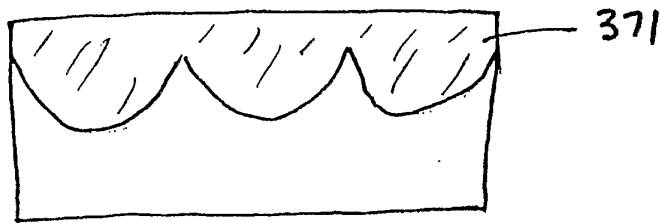


Fig. 23b

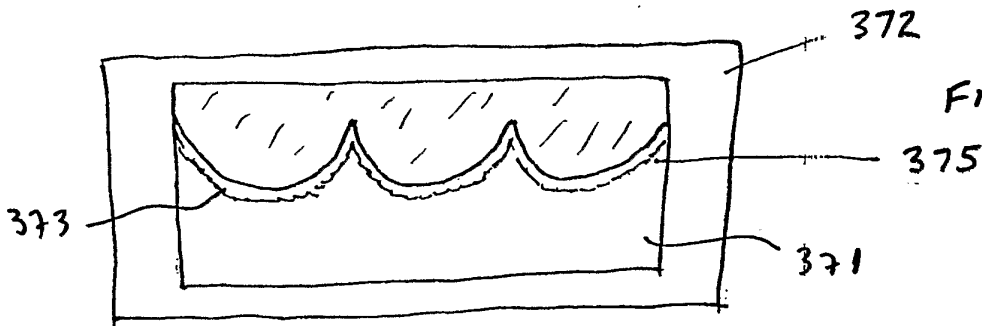


Fig. 23c

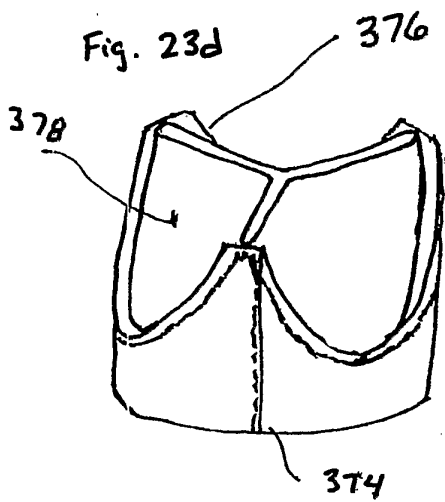


Fig. 23d

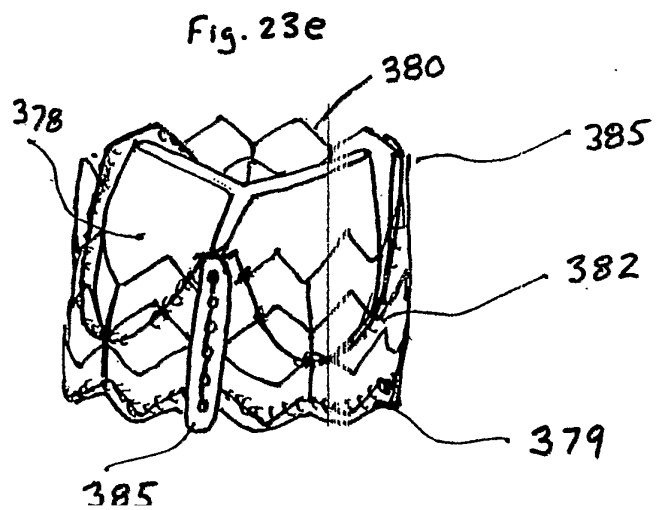


Fig. 23e

FIG. 24a

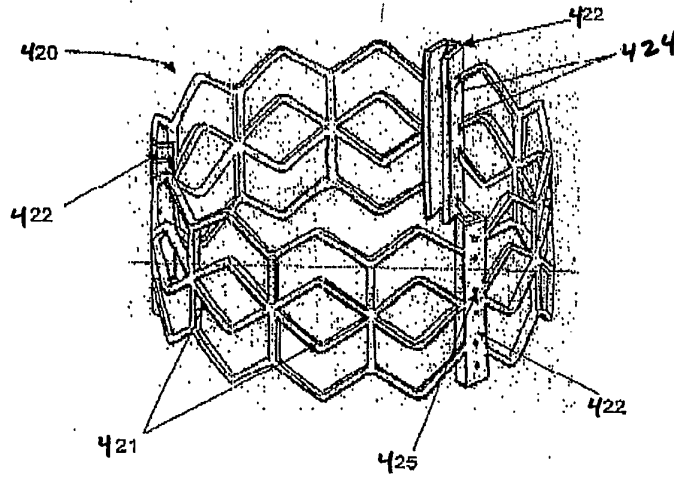


FIG - 24c

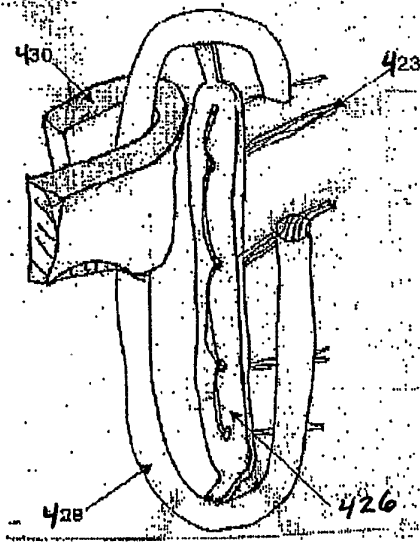


FIG - 24b

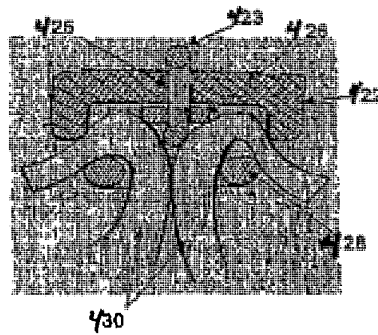


FIG - 25a

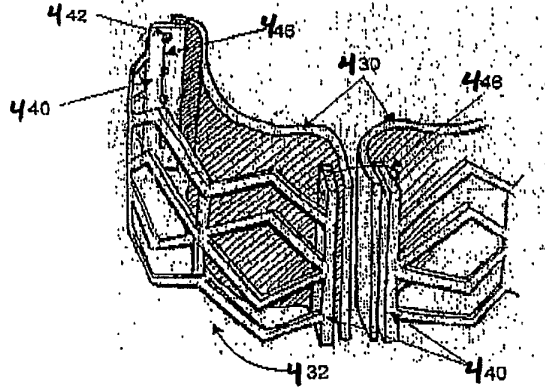


FIG - 25b

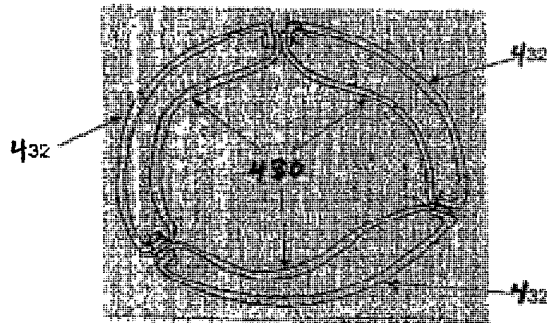


FIG - 25c



FIG - 25d

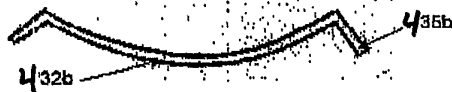


FIG - 26a

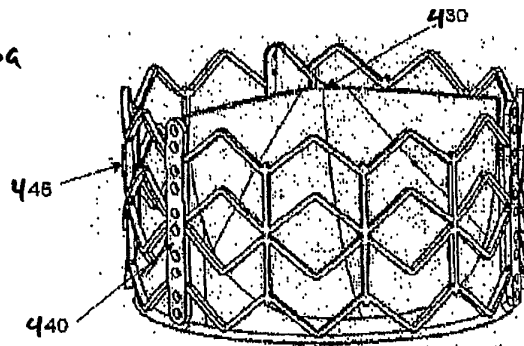


FIG - 26b

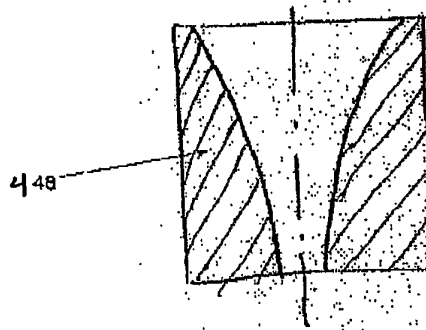
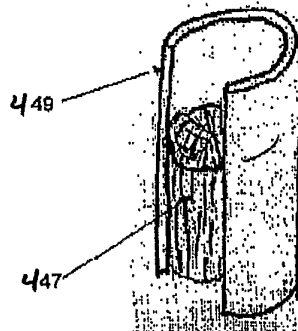


FIG - 26c



**FIG. 27**

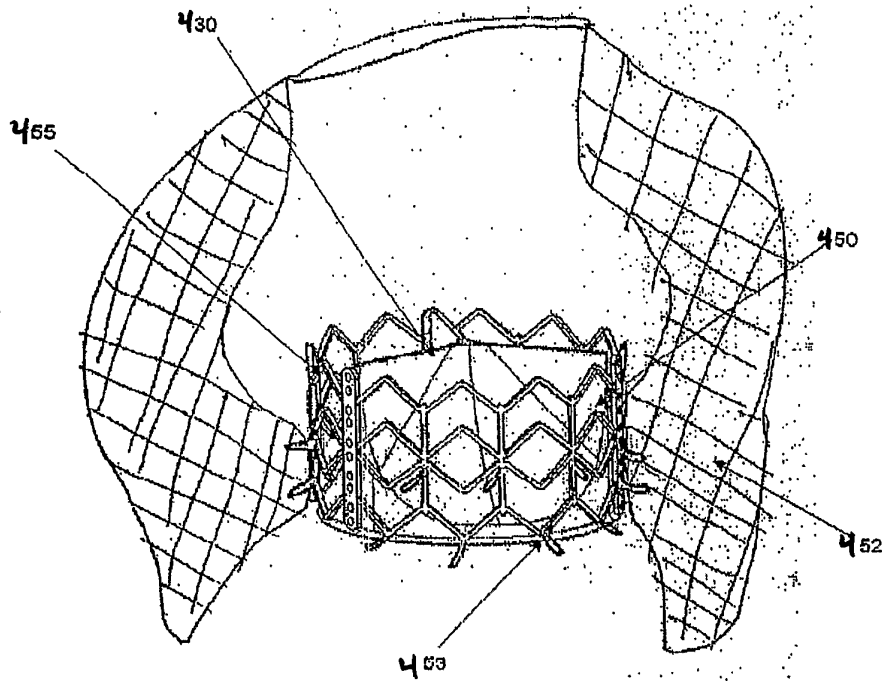


FIG. 28

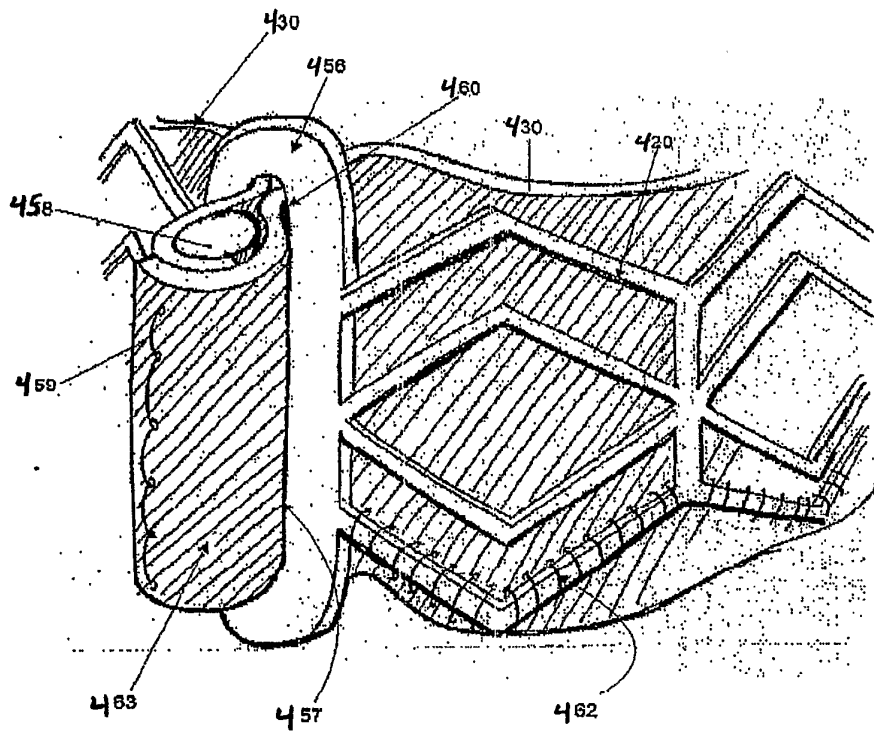


FIG - 29a

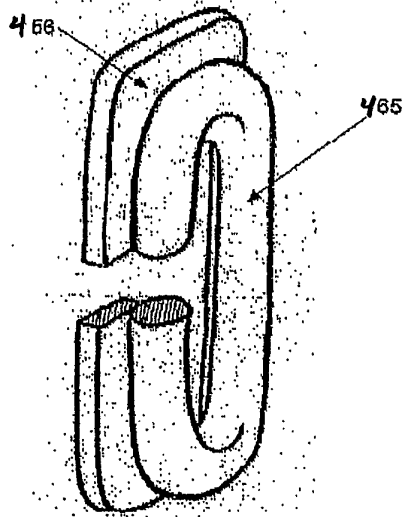
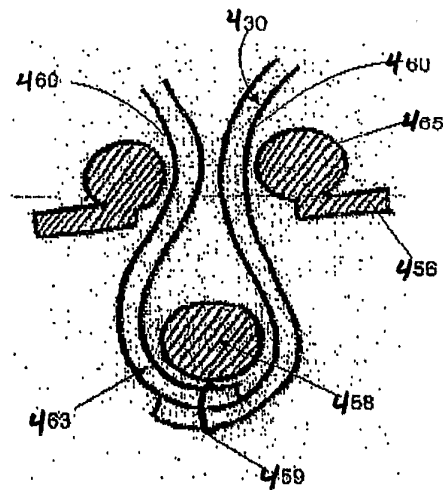


FIG - 29b





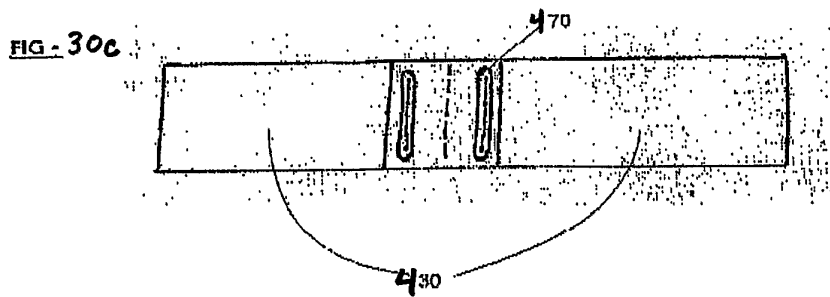
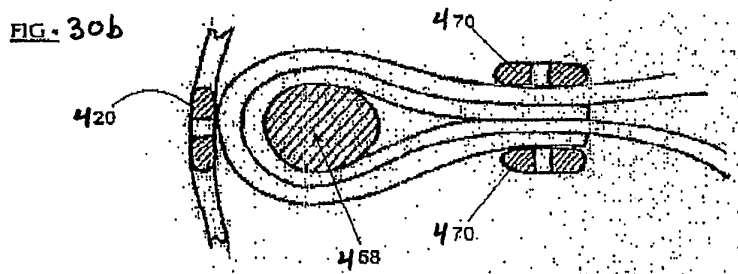
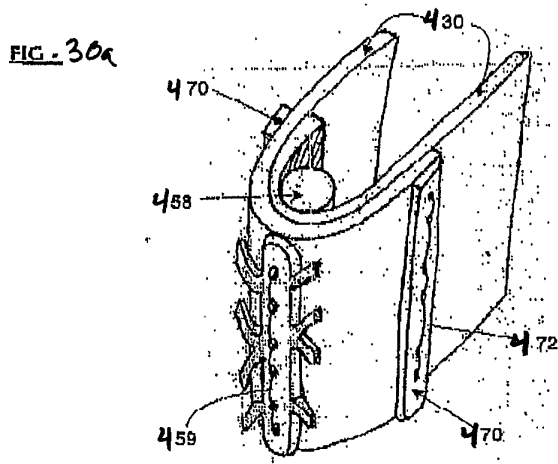


FIG - 31a

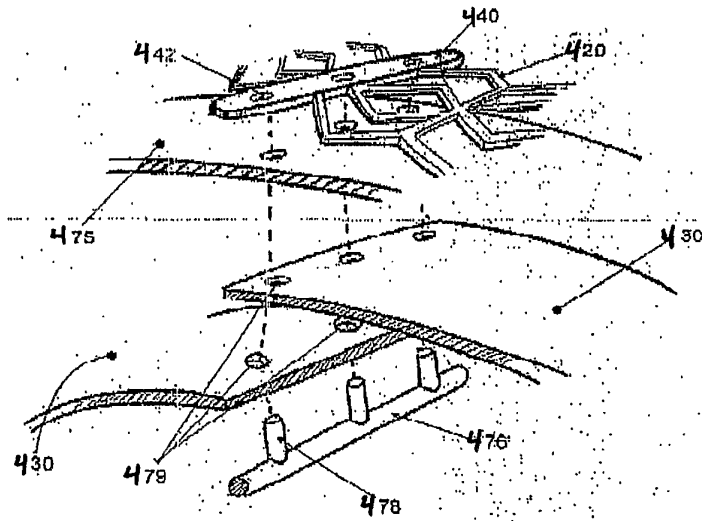
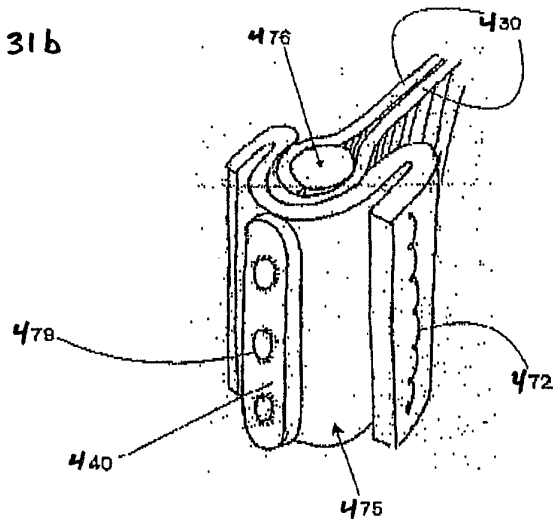


FIG - 31b



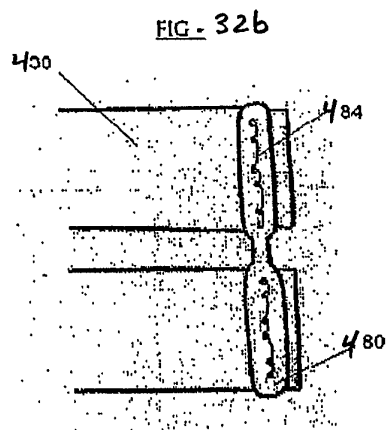
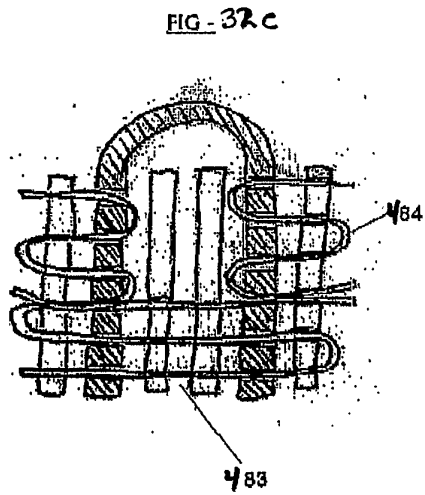
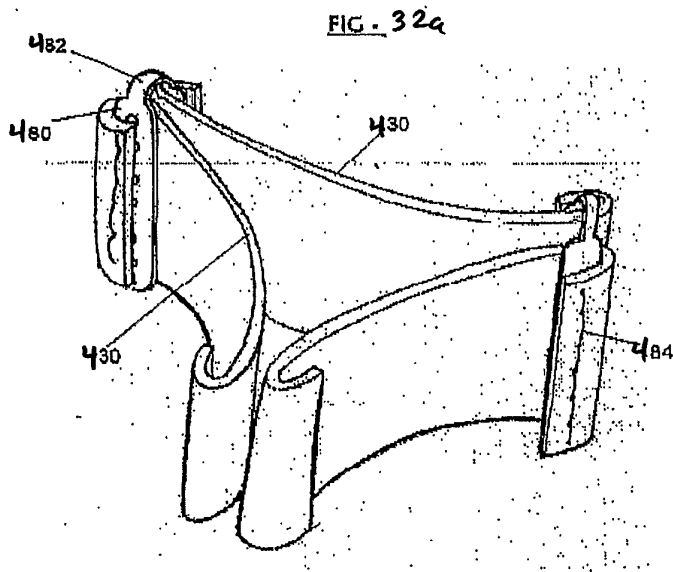


FIG. 33a

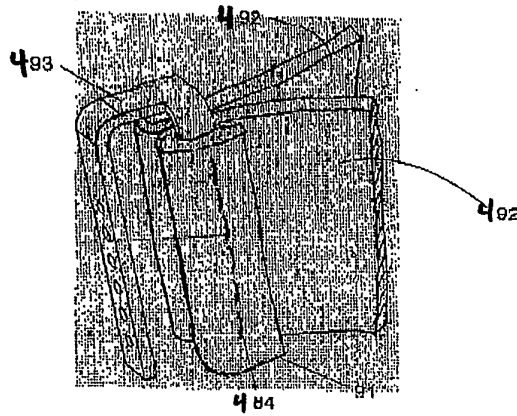


FIG. 33b

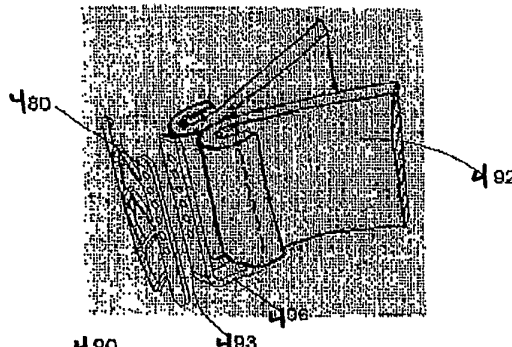


FIG. 33d

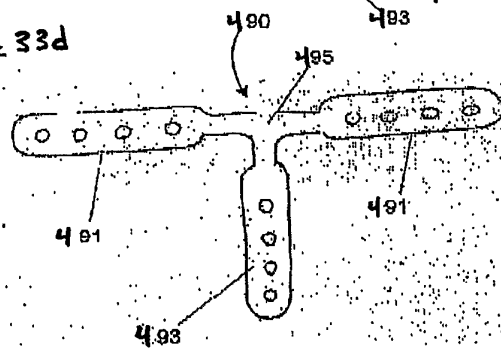
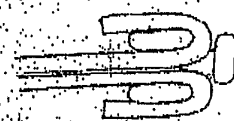


FIG. 33c



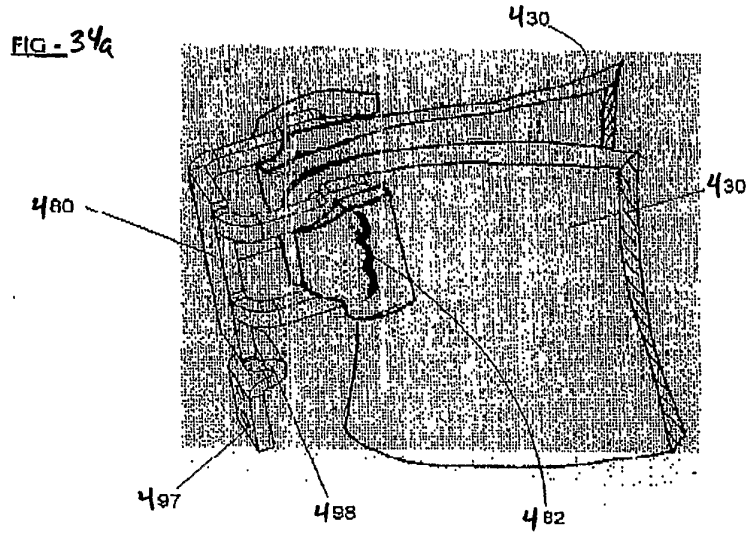


FIG - 34c

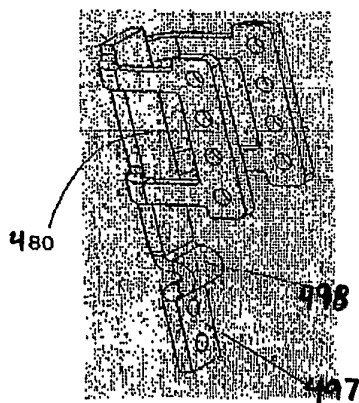
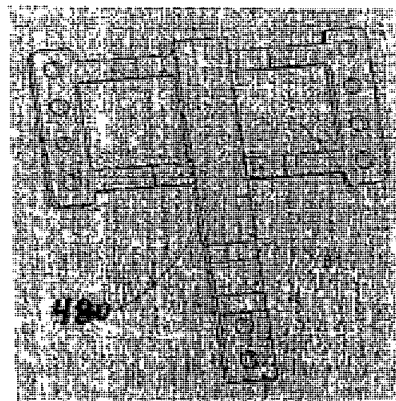
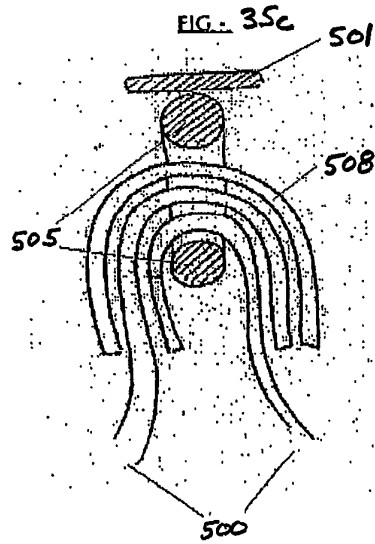
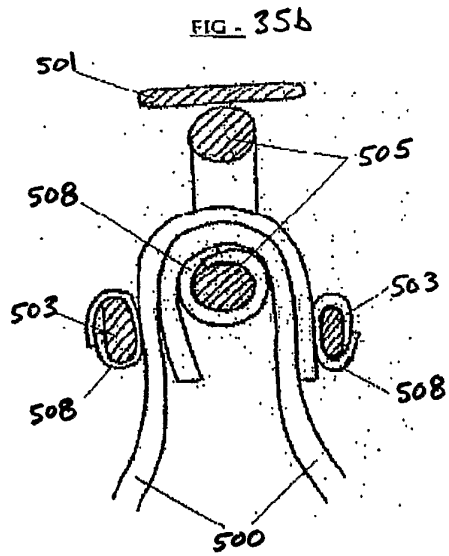
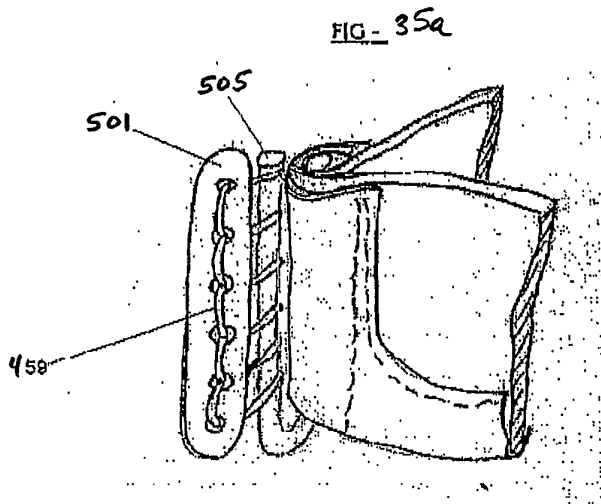


FIG - 34b





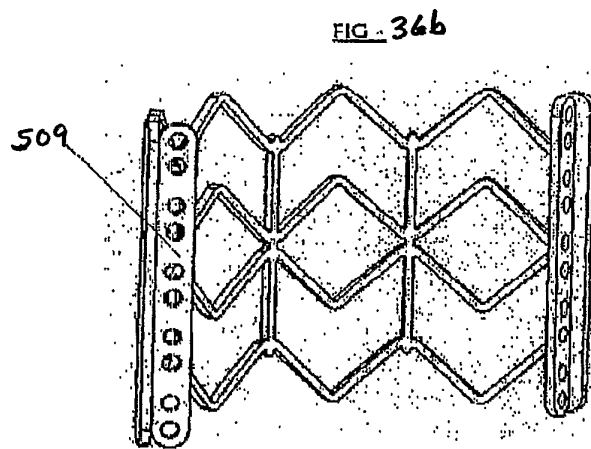
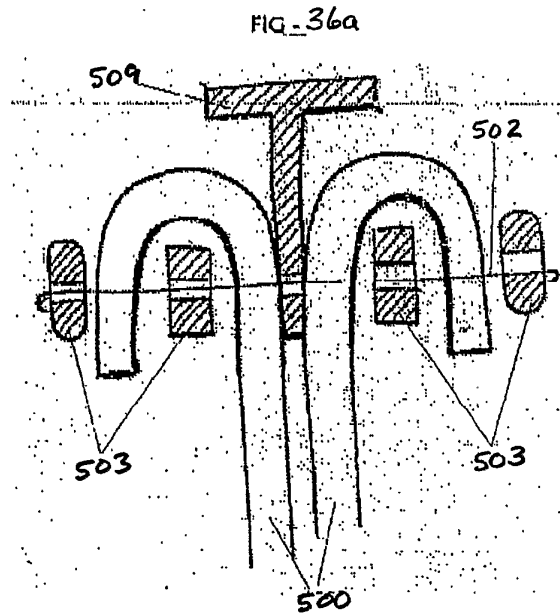


FIG. 37a

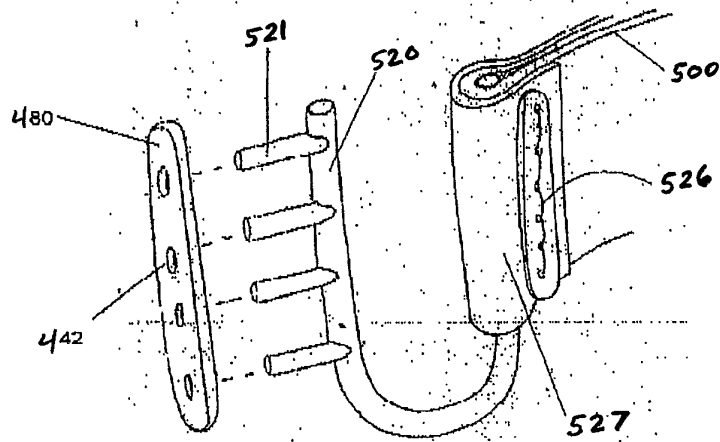


FIG. 37b

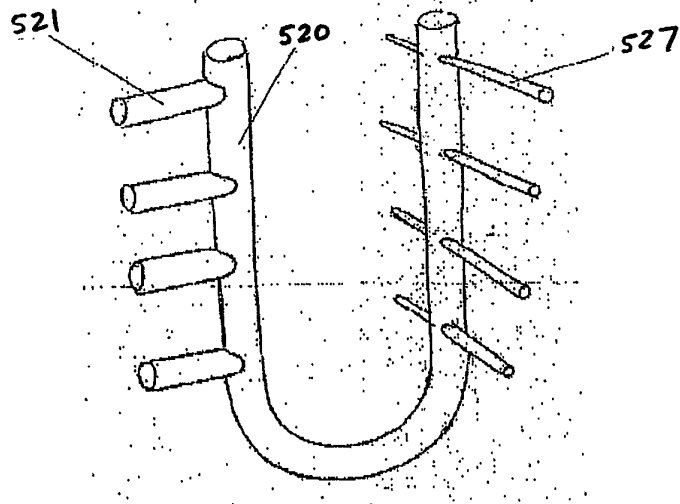
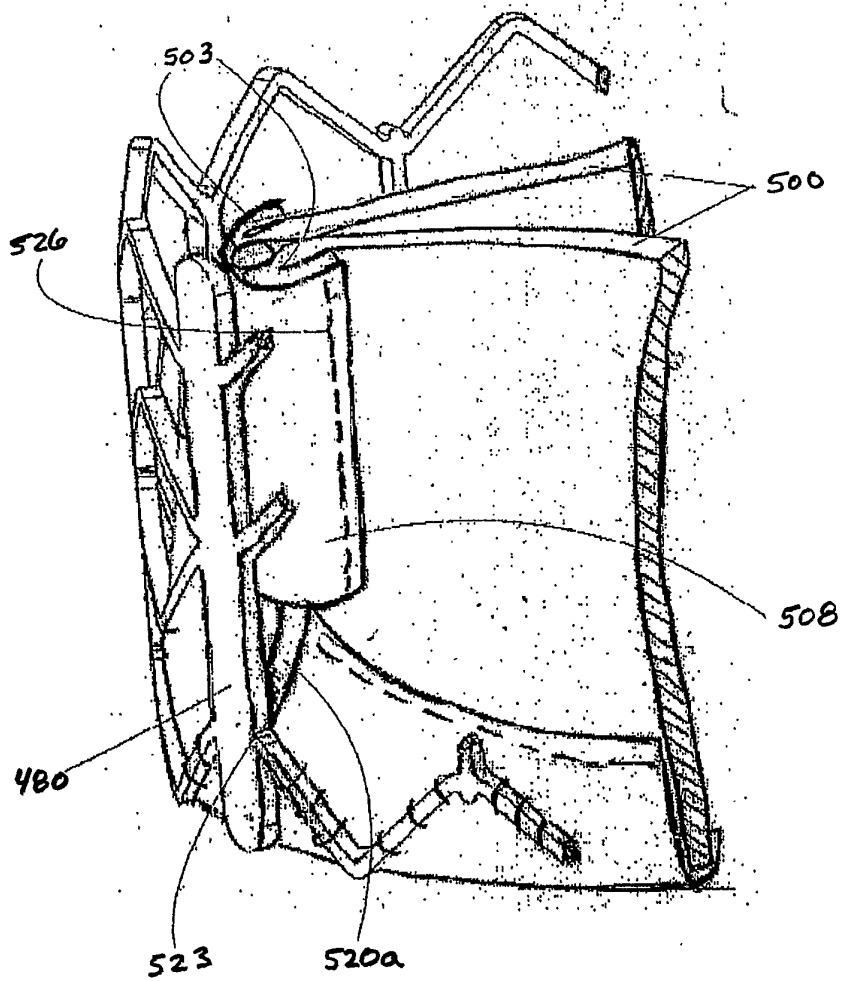
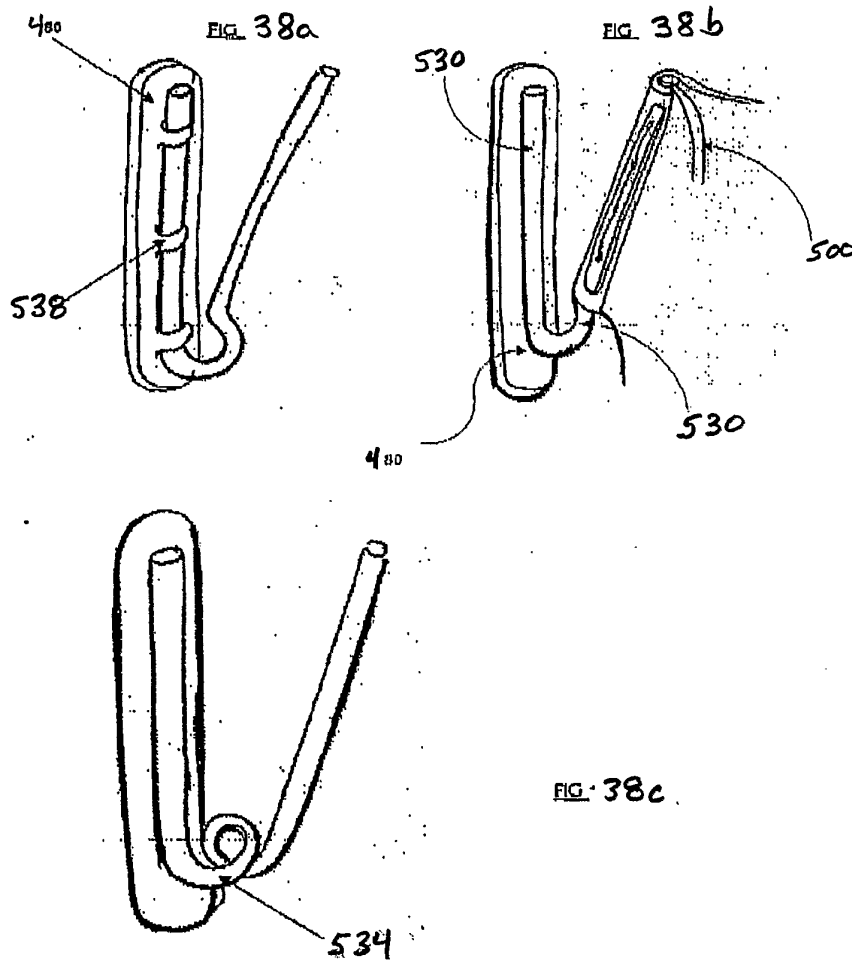
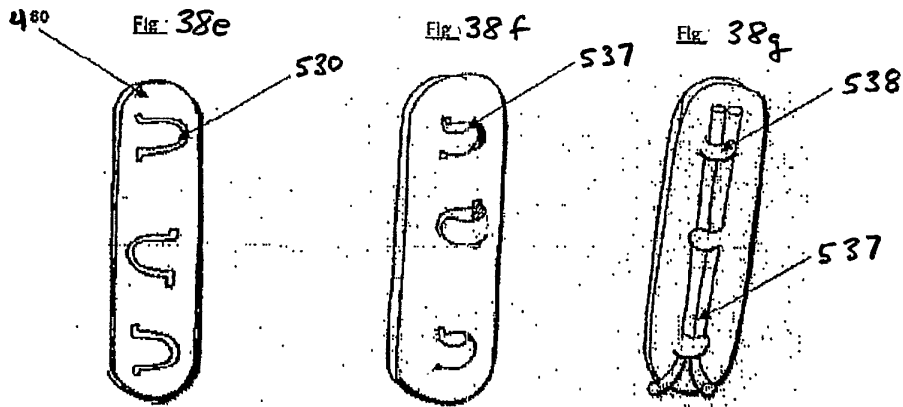
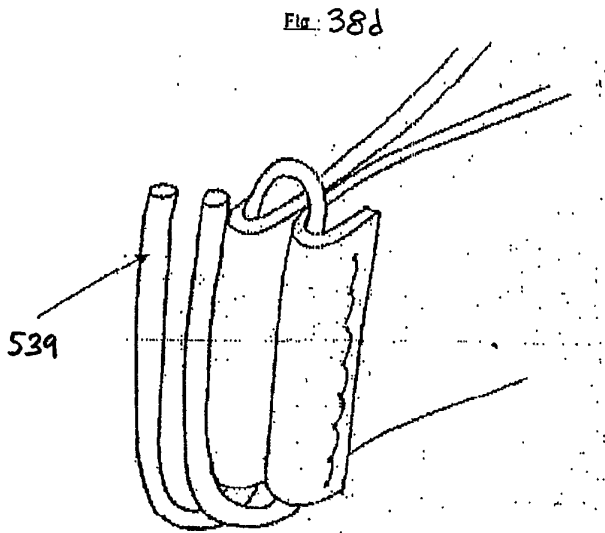


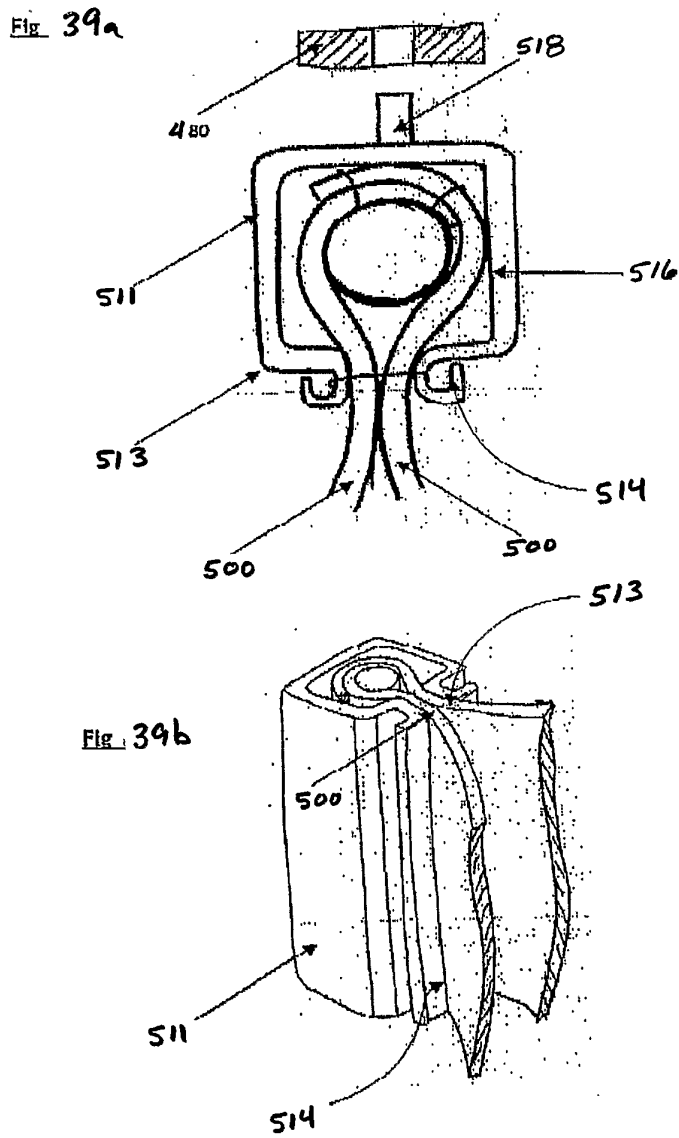


FIG. 37c









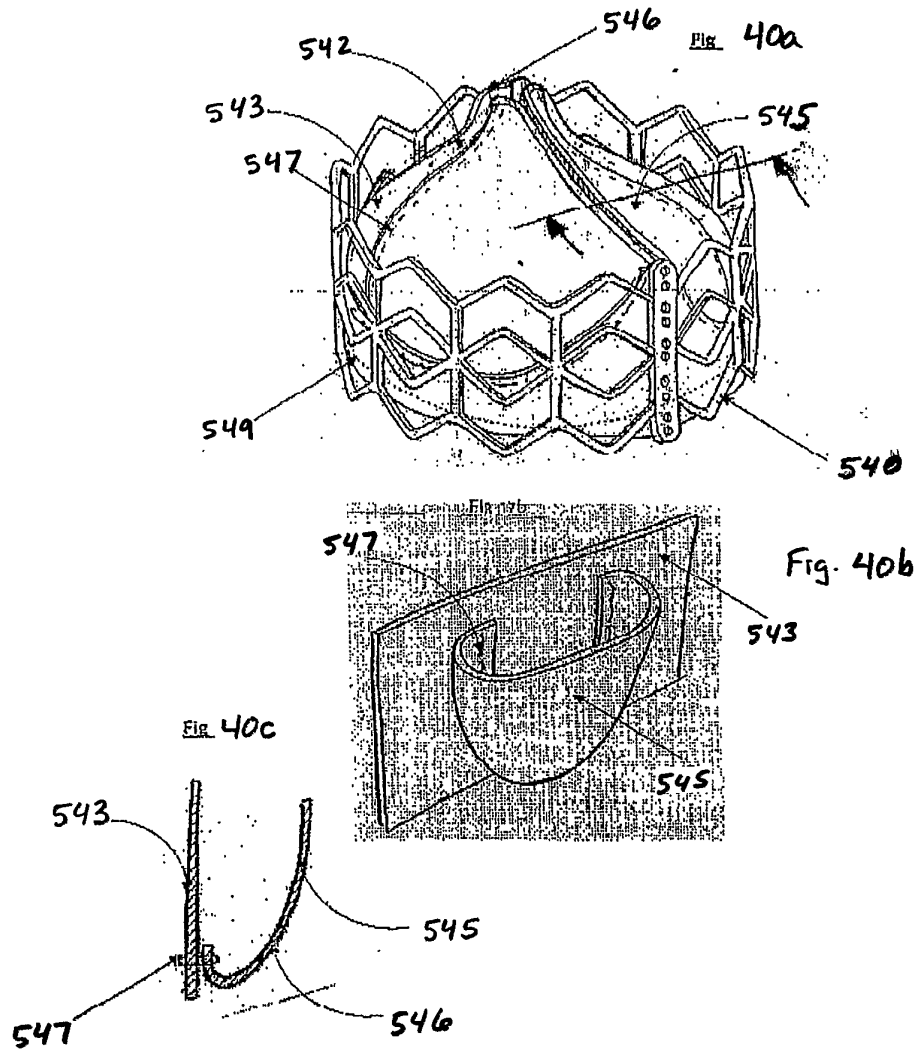


FIG. 41a

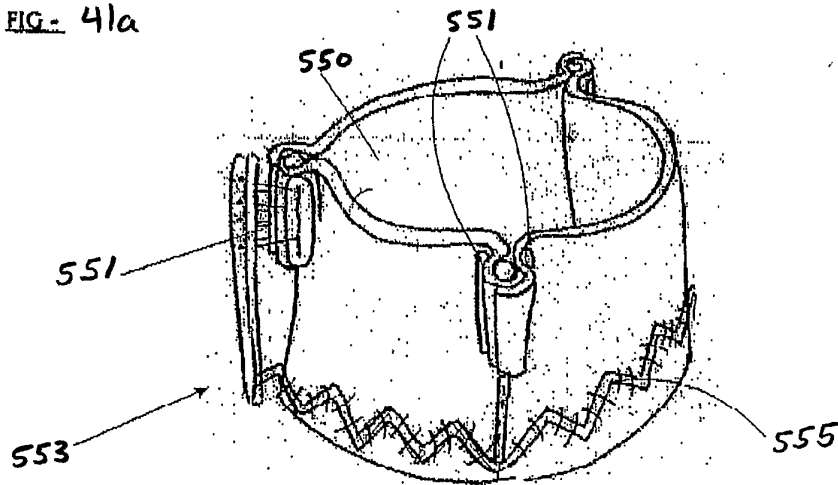


FIG. 41b

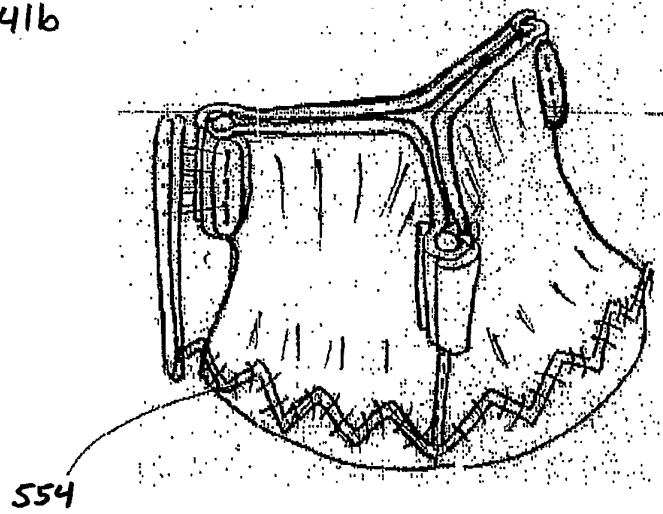


Fig. 41c

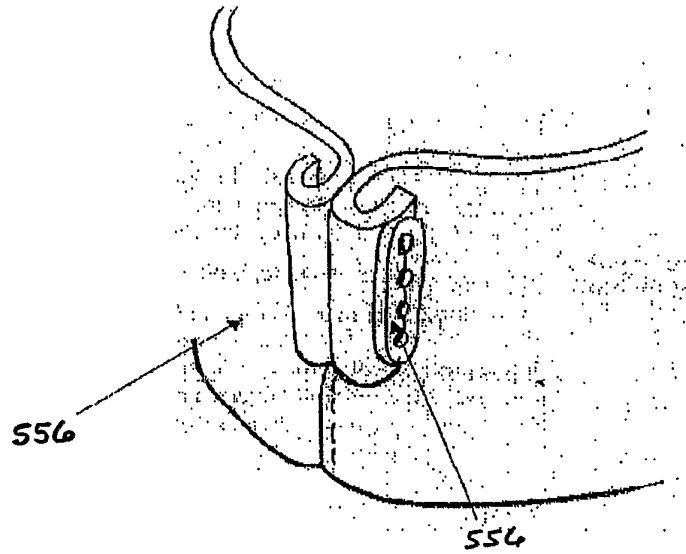
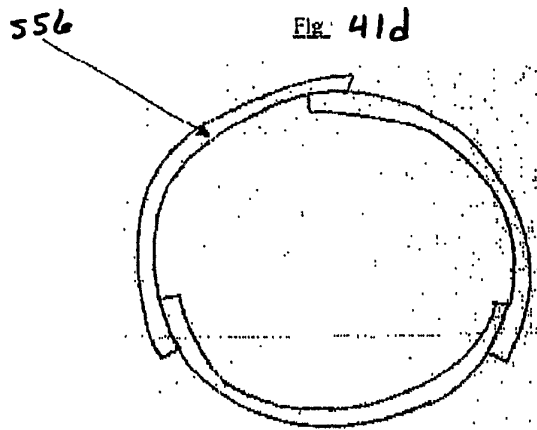
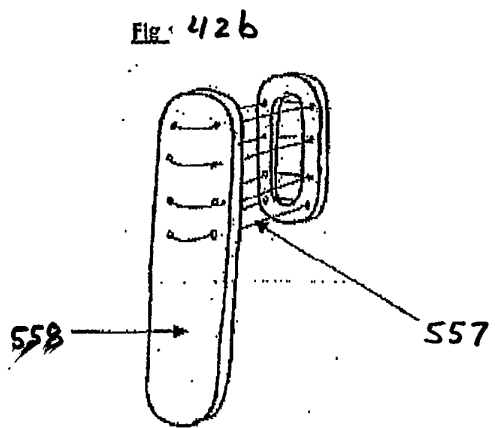
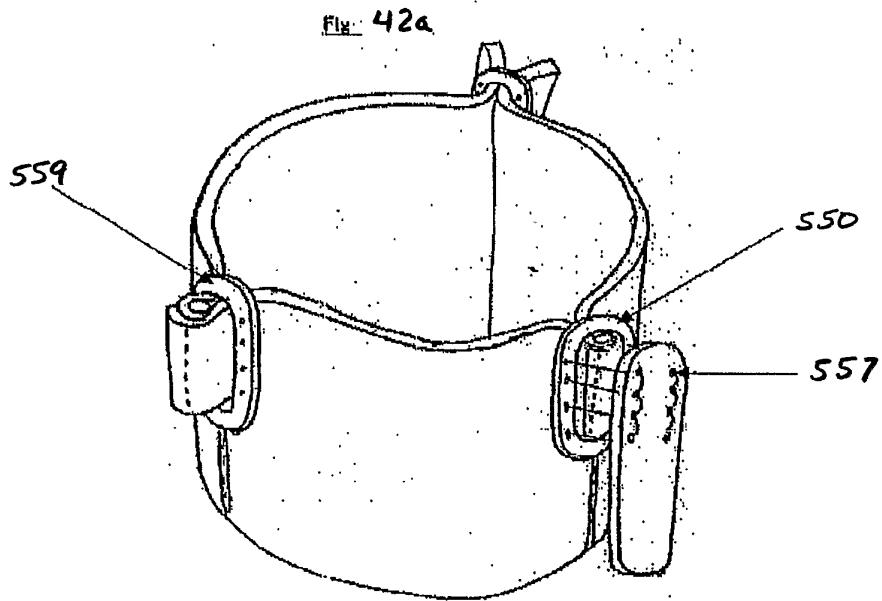


Fig. 41d







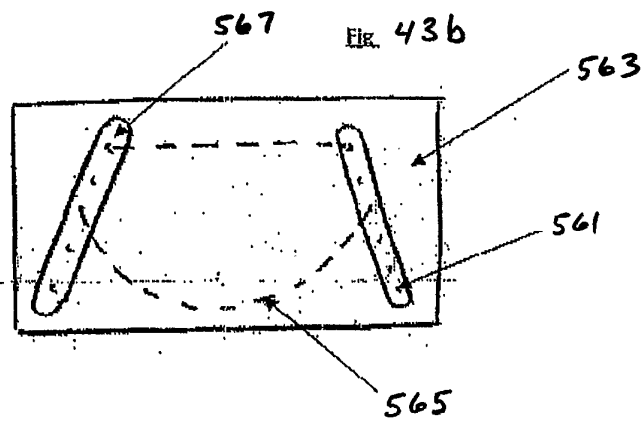
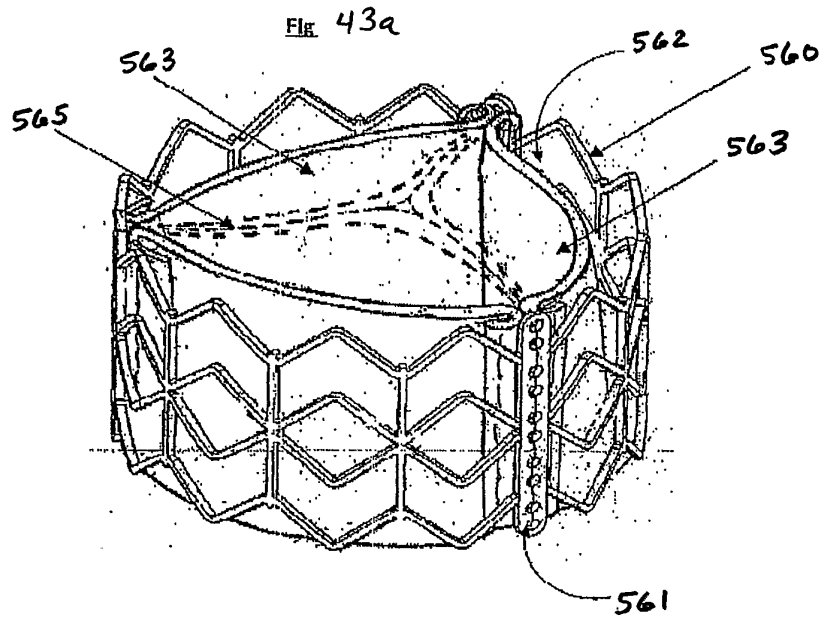


Fig. 44a

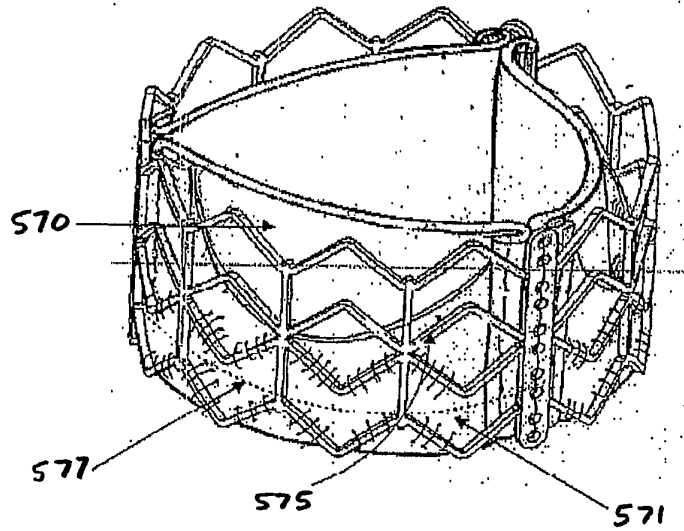


Fig. 44b

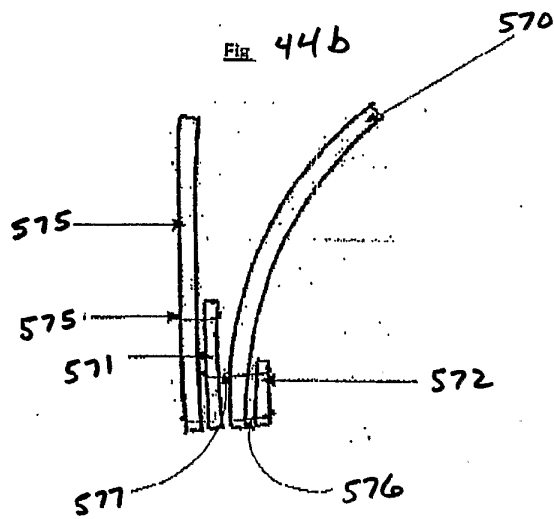


Fig. 44c

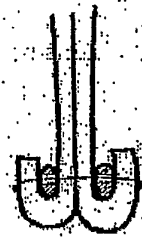


FIG. 45a

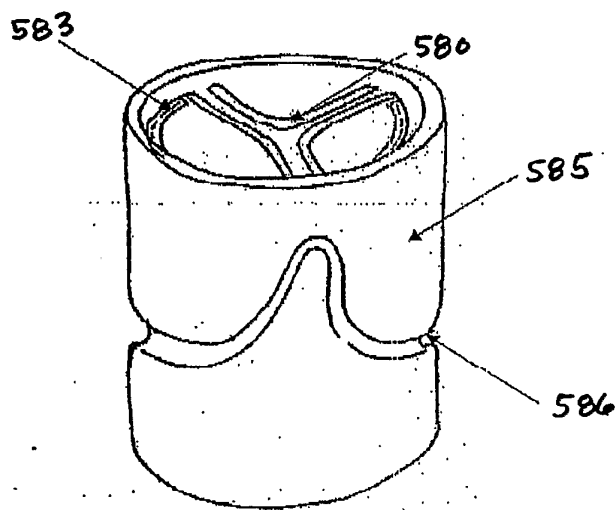


FIG. 45b

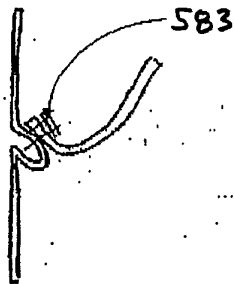


FIG. 45c

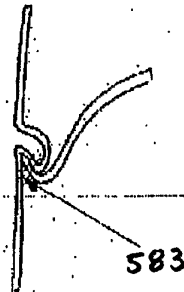
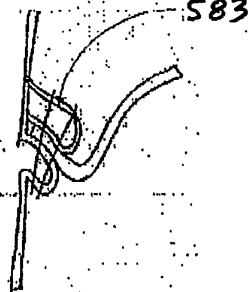


FIG. 45d



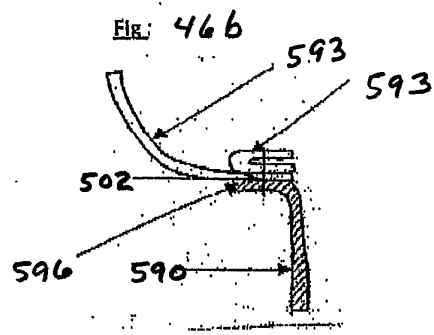
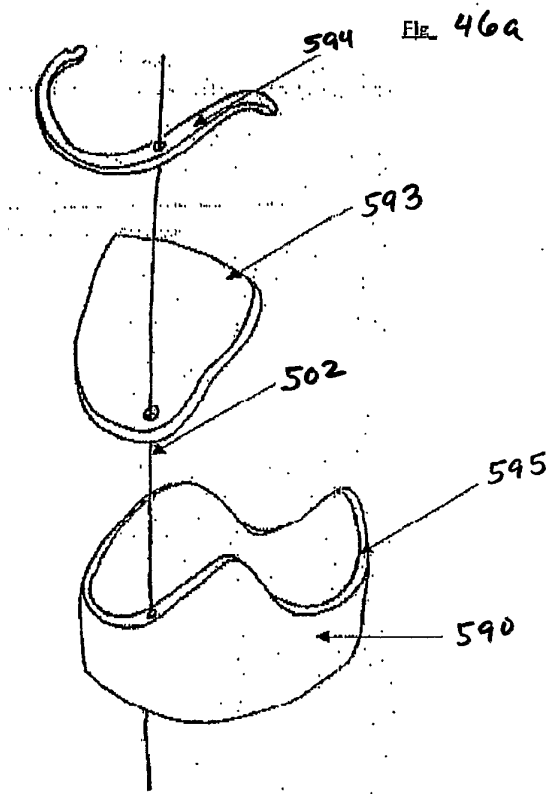


FIG. 47a

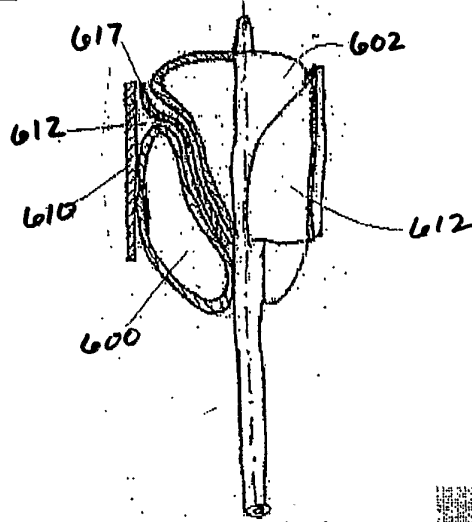


FIG. 47b

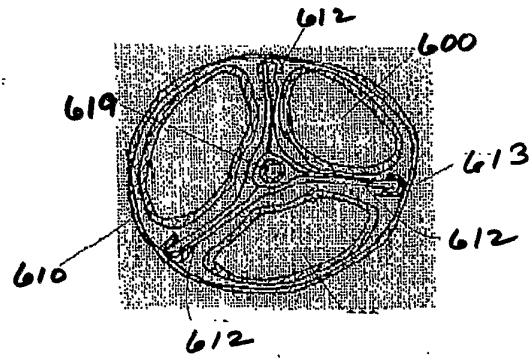


FIG. 47c



FIG. 48a

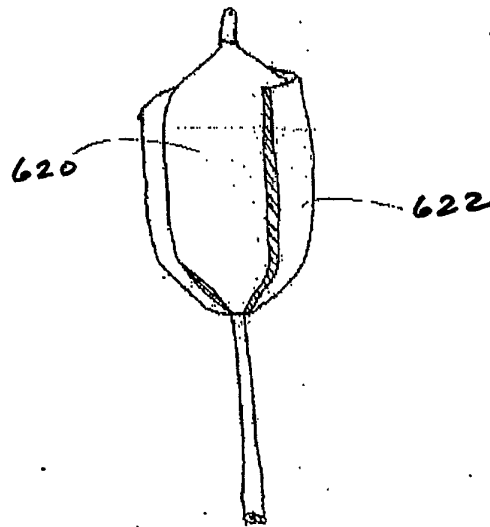
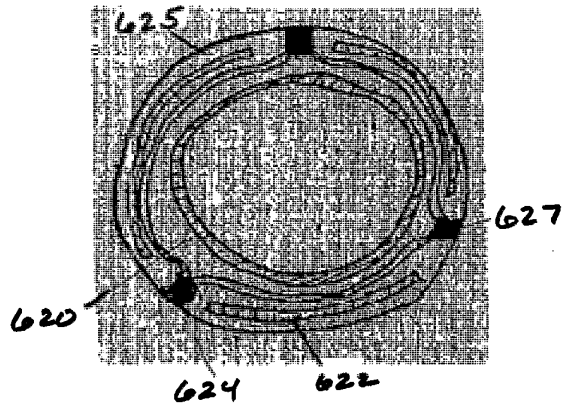


FIG. 48b



**INTERNATIONAL SEARCH REPORT**

International application No.  
PCT/US02/32588

**A. CLASSIFICATION OF SUBJECT MATTER**  
 IPC(7) : A61F 2/24  
 US CL : 623/2.17  
 According to International Patent Classification (IPC) or to both national classification and IPC

**B. FIELDS SEARCHED**  
 Minimum documentation searched (classification system followed by classification symbols)  
 U.S. : 623/2.17, 2.12

Documentation searched other than minimum documentation to the extent that such documents are included in the fields searched

Electronic data base consulted during the international search (name of data base and, where practicable, search terms used)

**C. DOCUMENTS CONSIDERED TO BE RELEVANT**

Category *	Citation of document, with indication, where appropriate, of the relevant passages	Relevant to claim No.
X, P	US 6,454,799 B1 (SCHRECK) 24 September 2002 (24.09.2002), see Figures, see entire document.	1-74
A	US 5,840,081 A (ANDERSEN et al.) 24 November 1998 (24.11.1998), see entire document.	1-74
A,P	US 6,458,153 B1 (BAILEY et al.) 01 October 2002 (01.10.2002), see entire document.	1-74

Further documents are listed in the continuation of Box C.  See patent family annex.

* Special categories of cited documents:		
"A" document defining the general state of the art which is not considered to be of particular relevance	"T"	later document published after the international filing date or priority date and not in conflict with the application but cited to understand the principle or theory underlying the invention
"E" earlier application or patent published on or after the international filing date	"X"	document of particular relevance; the claimed invention cannot be considered novel or cannot be considered to involve an inventive step when the document is taken alone
"L" document which may throw doubts on priority claim(s) or which is cited to establish the publication date of another citation or other special reason (as specified)	"Y"	document of particular relevance; the claimed invention cannot be considered to involve an inventive step when the document is combined with one or more other such documents, such combination being obvious to a person skilled in the art
"O" document referring to an oral disclosure, use, exhibition or other means	"&"	document member of the same patent family
"P" document published prior to the international filing date but later than the priority date claimed		

Date of the actual completion of the international search 14 January 2003 (14.01.2003)	Date of mailing of the international search report 06 FEB 2003
Name and mailing address of the ISA/US Commissioner of Patents and Trademarks Box PCT Washington, D.C. 20231 Facsimile No. (703)305-3230	Authorized officer <i>Javier G. Blanco</i> Javier G. Blanco Telephone No. 703-605-4259

(12) INTERNATIONAL APPLICATION PUBLISHED UNDER THE PATENT COOPERATION TREATY (PCT)

(19) World Intellectual Property Organization  
International Bureau



(43) International Publication Date  
13 November 2003 (13.11.2003)

(10) International Publication Number  
**PCT WO 03/092554 A1**

- (51) International Patent Classification: **A61F 2/24**
- (21) International Application Number: PCT/US03/14160
- (22) International Filing Date: 5 May 2003 (05.05.2003)
- (25) Filing Language: English
- (26) Publication Language: English
- (30) Priority Data:  
60/377,721 3 May 2002 (03.05.2002) US
- (71) Applicant (for all designated States except US): **THE GENERAL HOSPITAL CORPORATION** [---/US]; 53 Fruit Street, Boston, MA 02114 (US).
- (81) Designated States (national): AE, AG, AL, AM, AT, AU, AZ, BA, BB, BG, BR, BY, BZ, CA, CH, CN, CO, CR, CU, CZ, DE, DK, DM, DZ, EC, EE, ES, FI, GB, GD, GE, GH, GM, HR, HU, ID, IL, IN, IS, JP, KE, KG, KP, KR, KZ, LC, LK, LR, LS, LT, LU, LV, MA, MD, MG, MK, MN, MW, MX, MZ, NO, NZ, PH, PL, PT, RO, RU, SD, SE, SG, SK, SL, TJ, TM, TN, TR, TT, TZ, UA, UG, US, UZ, VN, YU, ZA, ZM, ZW.
- (84) Designated States (regional): ARIPO patent (GH, GM, KE, LS, MW, MZ, SD, SL, SZ, TZ, UG, ZM, ZW), Eurasian patent (AM, AZ, BY, KG, KZ, MD, RU, TJ, TM), European patent (AT, BE, BG, CH, CY, CZ, DE, DK, EE, ES, FI, FR, GB, GR, HU, IE, IT, LU, MC, NL, PT, RO, SE, SI, SK, TR), OAPI patent (BF, BJ, CF, CG, CI, CM, GA, GN, GQ, GW, ML, MR, NE, SN, TD, TG).

- (72) Inventor; and
- (75) Inventor/Applicant (for US only): **WHITE, Jennifer, K.** [US/US]; 102 Naples Road, Brookline, MA 02446 (US).
- (74) Agent: **BERNSTEIN, Jason, A.**, Powell, Goldstein, Frazer & Murphy LLP, 16th Floor, 391 Peachtree Street, Atlanta, GA 30303-1736 (US).

Published:  
— with international search report

For two-letter codes and other abbreviations, refer to the "Guidance Notes on Codes and Abbreviations" appearing at the beginning of each regular issue of the PCT Gazette.



(54) Title: INVOLUTED ENDOVASCULAR VALVE AND METHOD OF CONSTRUCTION



(57) Abstract: A prosthetic tri-leaflet valve formed by involuting a portion of a tubular structure inside itself. The valve can be made by a method comprising providing a tubular segment in which three equidistant longitudinal incisions are made in one end of the tube creating three flaps which are involuted, i.e., folded, in toward the inside of the tube and the edges of the flaps secured to the inner wall of the tube to form leaflets. The tube can be formed of a single sheet of synthetic, organic or biological material and can be solid, woven, braided or the like. A braided configuration permits the valve to be annularly compressed and delivered to the site using a minimally invasive delivery mechanism, then expanded at the implantation site.

WO 03/092554 A1